

**Status:** This is the original version (as it was originally made). This item of legislation is currently only available in its original format.

## SCHEDULE 6

### ROAD MARKINGS

#### SCHEDULE 6 ROAD MARKINGS

Regulation 11(1) and (3)



1001

Vehicular traffic must not proceed beyond the line when required to stop by light signals, by a constable in uniform or by a traffic warden

Item	
1	Regulations: 31, 43, 52
2	Directions: 18(1), 47
3	Diagrams: 1001.3, 1055.1, 1055.2, 3000, 3000.1, 3000.2, 3000.7, 3000.8, 3000.9, 3000.10, 3013, 3014
4	Permitted variants: None
5	Illumination requirements: Schedule 17, item 12

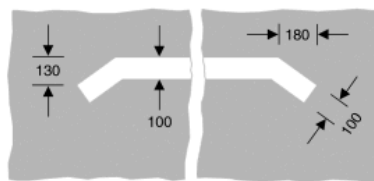

1001.1

Tramcars must not proceed beyond the line when required to stop by light signals

Item	
1	Regulations: 31, 43
2	Directions: 18(1)
3	Diagrams: 3013
4	Permitted variants: None
5	Illumination requirements: Schedule 17, item 12

**Status:** This is the original version (as it was originally made). This item of legislation is currently only available in its original format.

SCHEDULE 6 ROAD MARKINGS (contd.)

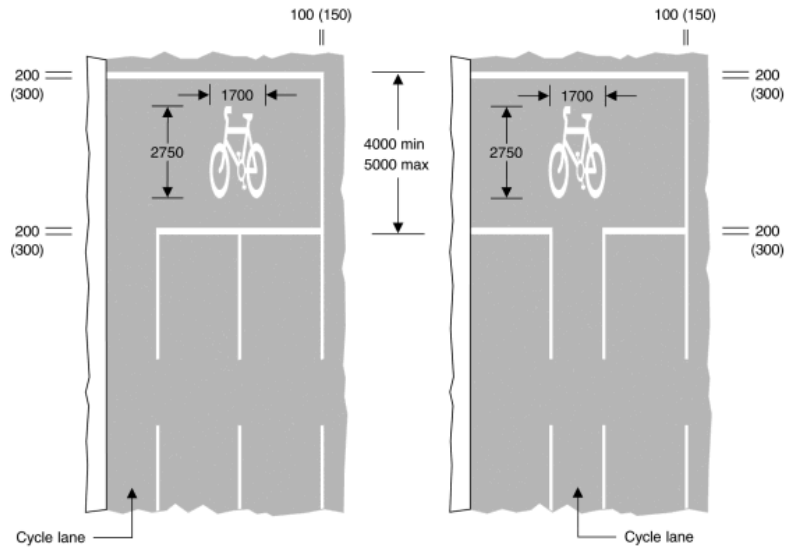

1001.2

Alternatives to the stop line shown in diagram 1001 showing separate stop lines at a junction for pedal cycles proceeding in the cycle lane

Item	
1	Regulations: 12(4), 31, 43
2	Directions: 18(1), 18(2), 47
3	Diagrams: 1004, 1004.1, 1057, 3000, 3000.7, 3000.8, 3000.9, 3000.10
4	Permitted variants: The number of traffic lanes may be varied. The nearside cycle lane may be bounded by the continuous white line shown in diagram 1049. The right hand longitudinal line may be omitted where that part of the carriageway is delineated by a raised kerb
5	Illumination requirements: Schedule 17, item 12

**Status:** This is the original version (as it was originally made). This item of legislation is currently only available in its original format.

SCHEDULE 6 ROAD MARKINGS (contd.)

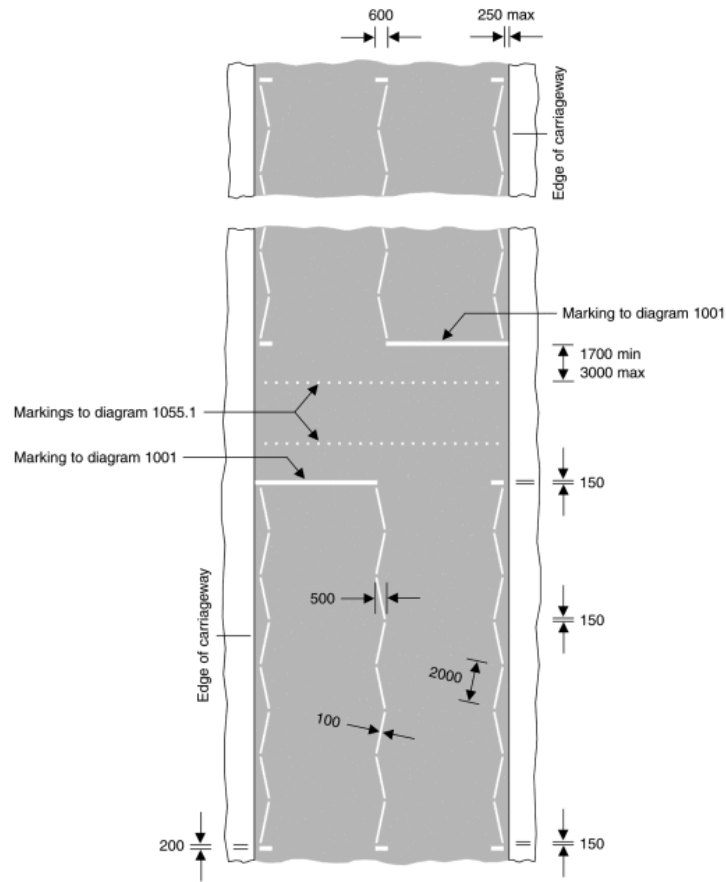

1001.3  
Zig-zag lines to indicate the requirements of regulations 27 and 28 at a Toucan or equestrian crossing facility controlled by signals (Shown in combination with diagrams 1001 and 1055.1)

Item	
1	Regulations: 4, 10(1), 10(2), 27, 28, 31(1)
2	Directions: 18(1), 49
3	Diagrams: 1001, 1055.1, 1055.2, 4002.1, 4003.1, 4003.2, 4003.4, 4003.5, 4003.7
4	Permitted variants: The marking and layout may be varied as prescribed in Schedule 4 to the Zebra, Pelican and Puffin Pedestrian Crossings Regulations and General Directions 1997 and shall comply with any requirements therein. Diagram 1055.2 may be substituted for diagram 1055.1
5	Illumination requirements: Schedule 17, item 12

**Status:** This is the original version (as it was originally made). This item of legislation is currently only available in its original format.

SCHEDULE 6 ROAD MARKINGS (contd.)



1002.1  
Vehicular traffic must not proceed beyond the line when required to stop by the sign shown in diagram 601.1

Item	
1	Regulations: 16, 31
2	Directions: 17, 18(3)
3	Diagrams: 601.1, 1022
4	Permitted variants: None
5	Illumination requirements: Schedule 17, item 12

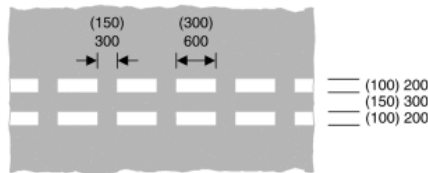

1003  
Vehicular traffic must give way in accordance with the requirements of regulation 25

Item	
1	Regulations: 4, 10(1), 16, 25, 31
2	Directions: 17, 18(1), 18(3), 18(5), 18(6), 34
3	Diagrams: 602, 611.1, 615, 955, 956, 957, 960.1, 1003.4, 1009, 1023, 1057
4	Permitted variants: None
5	Illumination requirements: Schedule 17, item 12

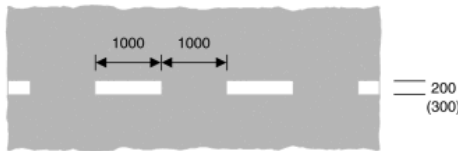

1003.1  
Vehicular traffic approaching a roundabout should give way at or immediately beyond the line to vehicular traffic circulating on the carriageway of the roundabout

Item	
1	Regulations: 31
2	Directions: None
3	Diagrams: None
4	Permitted variants: None
5	Illumination requirements: Schedule 17, item 12

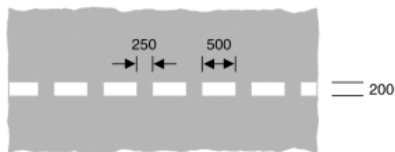

1003.2  
Pedestrians approaching a level crossing must wait behind the line when the barriers are closed or when the red figure shown in diagram 4006 or the light signals shown in diagram 3014 are showing or, if there are neither barriers nor light signals, until satisfied that it is safe to proceed

Item	
1	Regulations: 40, 52
2	Directions: None
3	Diagrams: 3014, 4006
4	Permitted variants: None
5	Illumination requirements: Schedule 17, item 12

**Status:** This is the original version (as it was originally made). This item of legislation is currently only available in its original format.

SCHEDULE 6 ROAD MARKINGS (contd.)

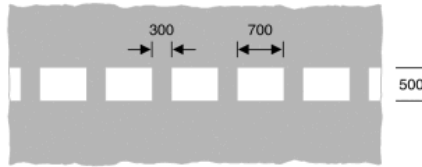

Item	
1	Regulations: 16, 31
2	Directions: 17, 18(1), 18(3)
3	Diagrams: 611.1, 1003.4, 1023
4	Permitted variants: None
5	Illumination requirements: Schedule 17, item 12

1003.3

Vehicular traffic approaching a roundabout with small central island or approaching a junction marked by signs as shown in diagram 611.1 should give way at or immediately beyond the line to traffic circulating on the carriageway of the roundabout

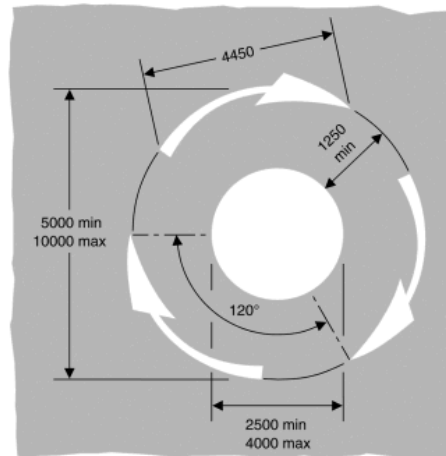
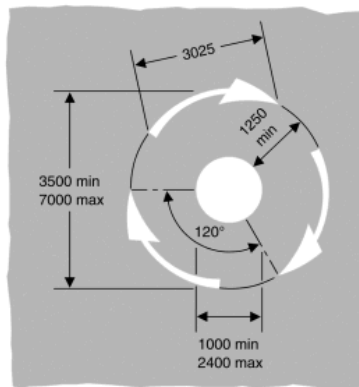

1003.4

Marking used in conjunction with the sign shown in diagram 611.1 and conveying the requirements prescribed by regulation 16 (Alternative types)

Item	
1	Regulations: 12(6), 16, 25, 31, 32(2)
2	Directions: 17, 18(1), 18(3)
3	Diagrams: 602, 611.1, 1003, 1003.3, 1023
4	Permitted variants: None
5	Illumination requirements: Schedule 17, item 12

**Status:** This is the original version (as it was originally made). This item of legislation is currently only available in its original format.

SCHEDULE 6 ROAD MARKINGS (contd.)

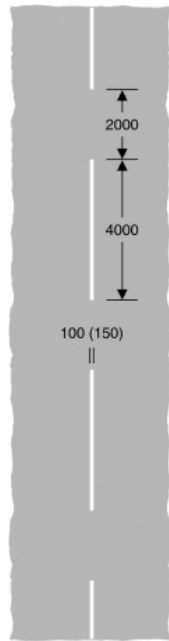

1004

Vehicular traffic on roads with a speed limit of 40 mph or less should not cross or straddle the line unless it is safe to do so, and when the line is used in conjunction with the sign in diagram 967 motor vehicles should not enter a cycle lane unless that lane is clear of pedal cycles

Item	
1	Regulations: 4, 31
2	Directions: 18(1)
3	Diagrams: 967, 1001.2, 1057, 1062
4	Permitted variants: None
5	Illumination requirements: Schedule 17, item 12

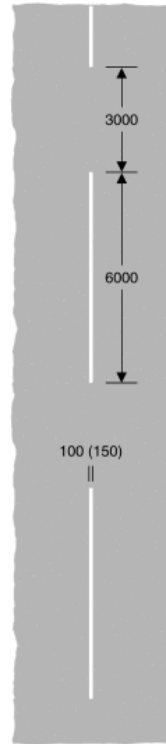

1004.1

As diagram 1004 on roads with a speed limit of more than 40 mph

Item	
1	Regulations: 4, 31
2	Directions: 18(1)
3	Diagrams: 967, 1001.2, 1057
4	Permitted variants: None
5	Illumination requirements: Schedule 17, item 12

**Status:** This is the original version (as it was originally made). This item of legislation is currently only available in its original format.

SCHEDULE 6 ROAD MARKINGS (contd.)

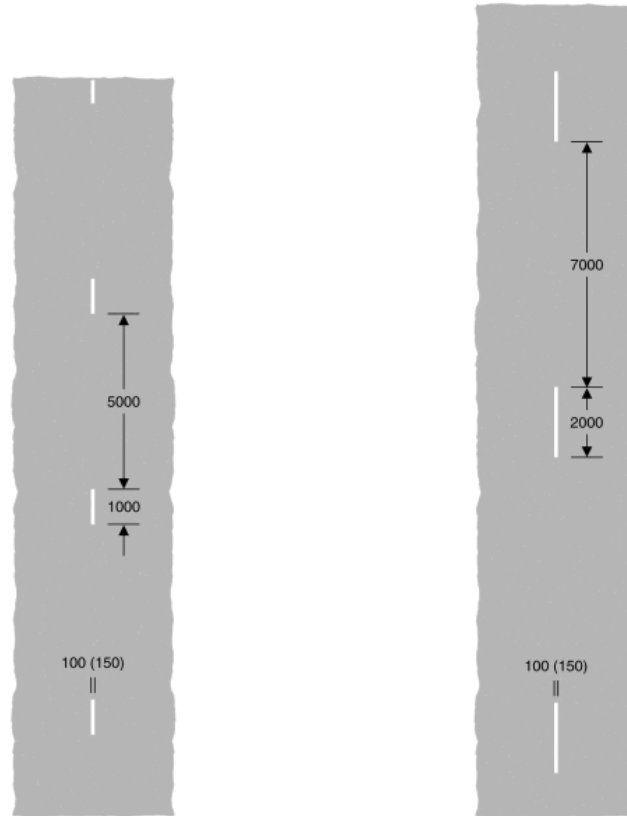

1005

Division of carriageway into traffic lanes on the part of the carriageway where vehicles normally proceed in the same direction on roads with a speed limit of 40 mph or less other than at places where the marking shown in diagram 1004 is used

Item	
1	Regulations: 4, 31
2	Directions: None
3	Diagrams: None
4	Permitted variants: None
5	Illumination requirements: Schedule 17, item 12

1005.1

As diagram 1005 on roads with a speed limit of more than 40 mph other than at places where the marking shown in diagram 1004.1 is used

Item	
1	Regulations: 4, 31
2	Directions: None
3	Diagrams: None
4	Permitted variants: None
5	Illumination requirements: Schedule 17, item 12

**Status:** This is the original version (as it was originally made). This item of legislation is currently only available in its original format.

SCHEDULE 6 ROAD MARKINGS (contd.)

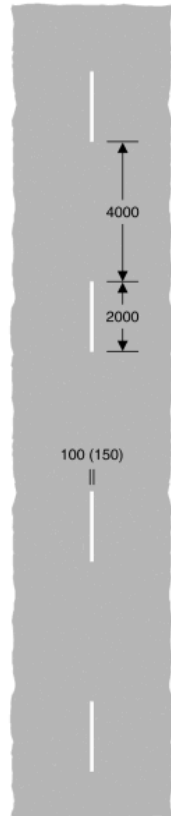

1008

Division between opposing flows of traffic on a carriageway with a speed limit of 40 mph or less other than at places where the marking shown in diagram 1004 is used

Item	
1	Regulations: 4, 31
2	Directions: None
3	Diagrams: None
4	Permitted variants: None
5	Illumination requirements: Schedule 17, item 12

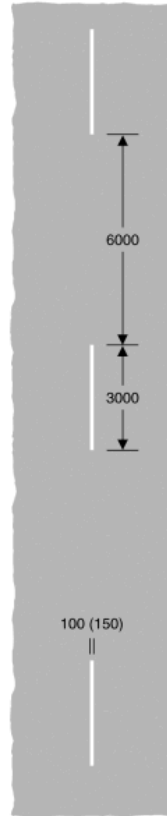

1008.1

Division between opposing flows of traffic on a carriageway with a speed limit of more than 40 mph other than at places where the marking shown in diagram 1004.1 is used

Item	
1	Regulations: 4, 31
2	Directions: None
3	Diagrams: None
4	Permitted variants: None
5	Illumination requirements: Schedule 17, item 12



**Status:** This is the original version (as it was originally made). This item of legislation is currently only available in its original format.

SCHEDULE 6 ROAD MARKINGS (contd.)

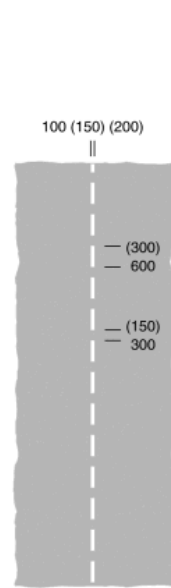

1009

Edge of the carriageway at a road junction, exit from a private drive onto a public road, or where laid diagonally across part of the carriageway, the start of a cycle lane

Item	
1	Regulations: 4, 12(3), 31
2	Directions: 17, 18(6)
3	Diagrams: 958.1, 1003, 1023
4	Permitted variants: None
5	Illumination requirements: Schedule 17, item 12

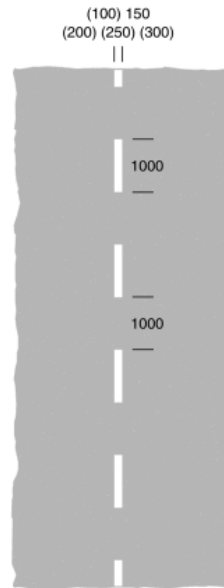

1010

- (a) Edge of the carriageway at a road junction or a lay-by, or at an exit from a private drive onto a public road; or
- (b) where laid diagonally across part of the carriageway, the start of a traffic lane, the boundary of which is indicated by diagram 1049; or
- (c) when used in conjunction with diagrams 1014 and 1024.1, the most suitable path to be taken by high vehicles under a low bridge or to avoid an overhanging structure; or
- (d) when laid alongside rails used by tramcars, the edge of the part of the carriageway used by the tramcars; or
- (e) the division between the main carriageway and a traffic lane which leaves the main carriageway at a junction ahead

Item	
1	Regulations: 4, 31
2	Directions: 17, 18(3)
3	Diagrams: 508.1, 509.1, 958, 1014, 1024.1, 1049
4	Permitted variants: None
5	Illumination requirements: Schedule 17, item 12

**Status:** This is the original version (as it was originally made). This item of legislation is currently only available in its original format.

SCHEDULE 6 ROAD MARKINGS (contd.)



1012.1

- (a) Edge of the carriageway available for through traffic other than at a road junction, an exit from a private drive onto a public road or a lay-by; or
- (b) the back edge of a hard shoulder; or
- (c) the edge of a footway where it passes over a railway or tramway level crossing

Item	
1	Regulations: 31
2	Directions: 18(1)
3	Diagrams: 1062
4	Permitted variants: The width of the line shall be 100 millimetres when it is used to delineate the back edge of a hard shoulder
5	Illumination requirements: Schedule 17, item 12

**Status:** This is the original version (as it was originally made). This item of legislation is currently only available in its original format.

SCHEDULE 6 ROAD MARKINGS (contd.)

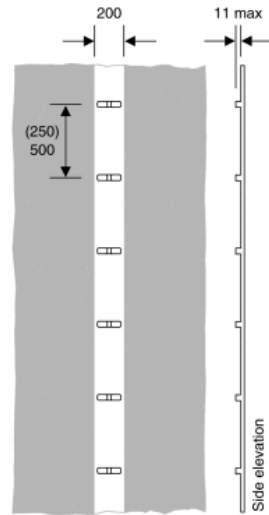

1012.2

Alternative to the marking shown in diagram 1012.1, as described in caption (a) to that diagram, incorporating an audible and tactile warning in the form of a raised rib for use on motorways

Item	
1	Regulations: 11(2), 31, 32(2)
2	Directions: 14(1)
3	Diagrams: None
4	Permitted variants: The notch may be omitted from the raised rib
5	Illumination requirements: Schedule 17, item 12

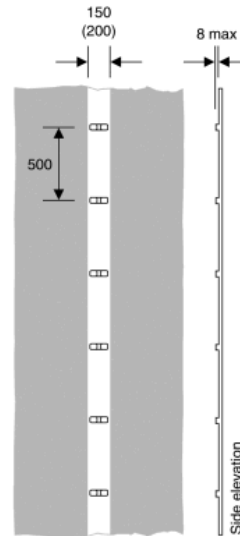

1012.3

As diagram 1012.2 for use on roads that are not motorways and which have hard strips or hard shoulders

Item	
1	Regulations: 11(2), 31, 32(2)
2	Directions: 13(3)
3	Diagrams: None
4	Permitted variants: The notch may be omitted from the raised rib. The width of the line shall be 200 millimetres when used on roads with hard shoulders
5	Illumination requirements: Schedule 17, item 12

**Status:** This is the original version (as it was originally made). This item of legislation is currently only available in its original format.

SCHEDULE 6 ROAD MARKINGS (contd.)

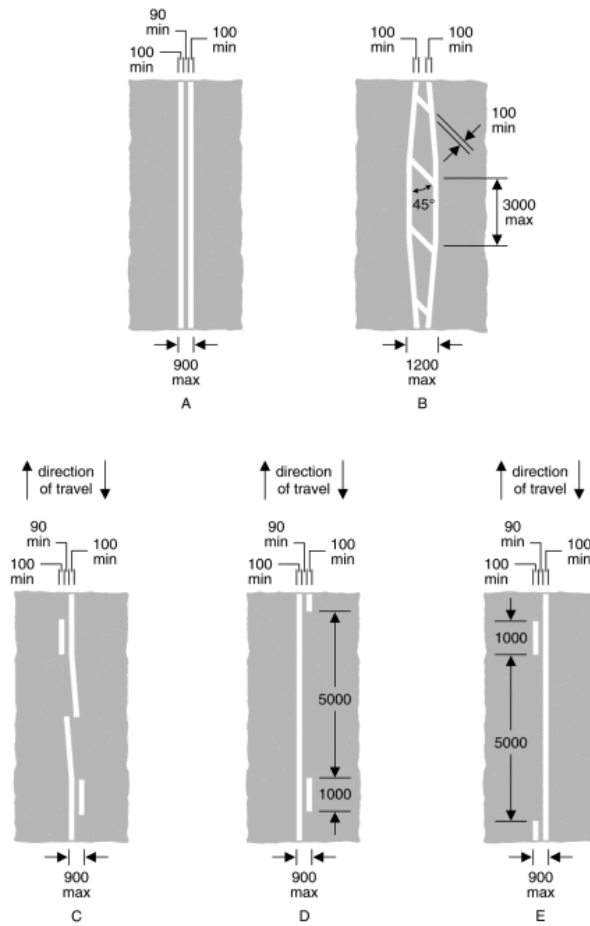

1013.1

Alternative methods of indicating to vehicular traffic the requirements and the warning prescribed in regulation 26

Item	
1	Regulations: 4, 10(1), 10(2), 26, 31
2	Directions: 18(1), 48
3	Diagrams: 1014, 1045 (when diagram 1013.1 is as shown in version A)
4	Permitted variants: None
5	Illumination requirements: Schedule 17, item 12

**Status:** This is the original version (as it was originally made). This item of legislation is currently only available in its original format.

SCHEDULE 6 ROAD MARKINGS (contd.)

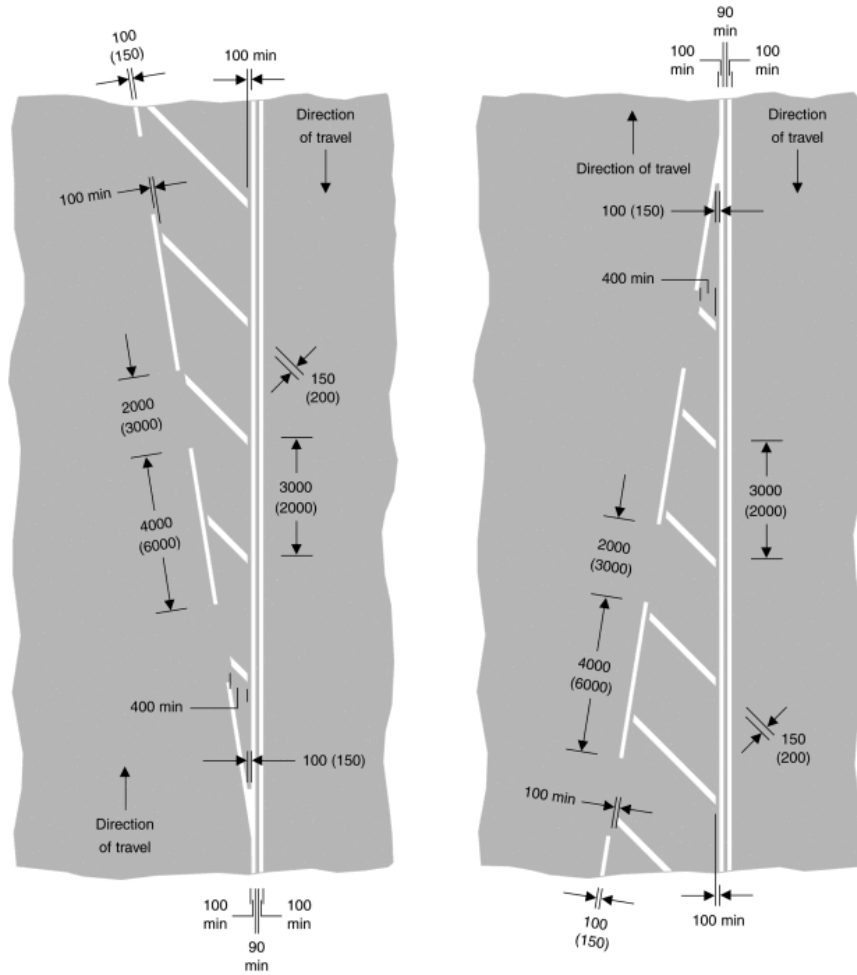

1013.3

As diagram 1013.1, with an adjacent part of the carriageway which vehicular traffic should not enter unless it is seen by the driver to be safe to do so

Item	
1	Regulations: 4, 10(1), 10(2), 12(4), 26, 31
2	Directions: 48
3	Diagrams: 1013.4, 1014
4	Permitted variants: None
5	Illumination requirements: Schedule 17, item 12

**Status:** This is the original version (as it was originally made). This item of legislation is currently only available in its original format.

SCHEDULE 6 ROAD MARKINGS (contd.)

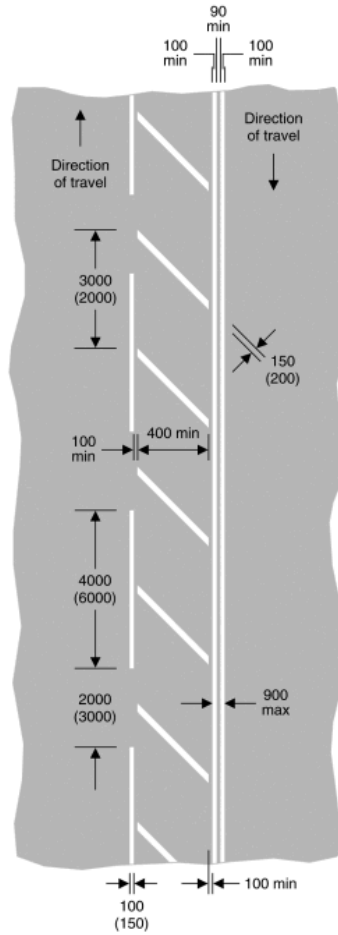

1013.4  
Same as diagram 1013.3

Item	
1	Regulations: 4, 10(1), 10(2), 12(4), 26, 31
2	Directions: None
3	Diagrams: 1013.3
4	Permitted variants: None
5	Illumination requirements: Schedule 17, item 12

**Status:** This is the original version (as it was originally made). This item of legislation is currently only available in its original format.

SCHEDULE 6 ROAD MARKINGS (contd.)

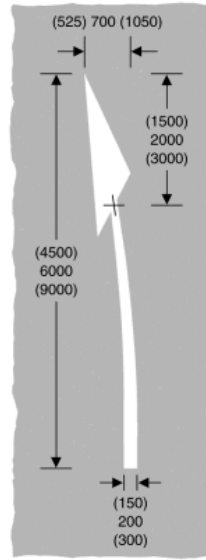

1014

- (a) Direction in which vehicular traffic should pass a road marking shown in diagram 1013.1, 1013.3, 1040, 1040.3, 1040.4 or 1049 ahead; or
- (b) obstruction on the carriageway ahead; or
- (c) when used in conjunction with the marking shown in diagram 1010, the most suitable path to be taken by high vehicles under a low bridge or to avoid an overhanging structure; or
- (d) reduction in the number of traffic lanes on the carriageway ahead; or
- (e) path to be taken by vehicular traffic to avoid a route available for trams only

Item	
1	Regulations: 31
2	Directions: 18(3), 48
3	Diagrams: 1010, 1013.1, 1013.3, 1024.1, 1040, 1040.3, 1040.4, 1049
4	Permitted variants: The symbol may be reversed in a mirror image
5	Illumination requirements: Schedule 17, item 12

**Status:** This is the original version (as it was originally made). This item of legislation is currently only available in its original format.

SCHEDULE 6 ROAD MARKINGS (contd.)

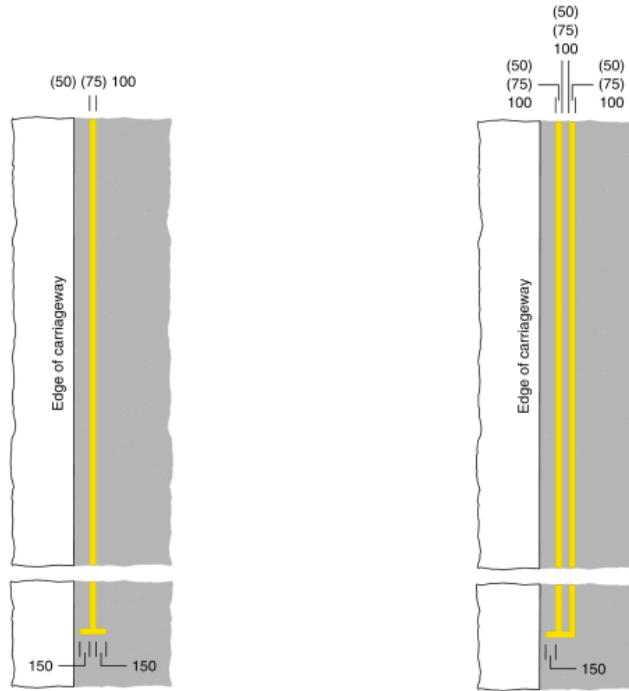

**1017**  
Waiting of vehicles on a side of a length of road prohibited for a time less than that specified in caption (a) to diagram 1018.1

**1018.1**  
(a) Waiting of vehicles on a side of a length of road prohibited at any time during a period of at least 4 consecutive months; or  
(b) Stopping of vehicles in a lay-by prohibited except in emergency

Item	
1	Regulations: 4
2	Directions: 7, 18(1), 22, 24(1), 24(4), 25
3	Diagrams: 637.2, 639, 639.1B, 640, 650.3, 663, 663.1, 1062
4	Permitted variants: None
5	Illumination requirements: Schedule 17, item 12

Item	
1	Regulations: 4
2	Directions: 7, 18(1), 22, 24(1), 24(4)
3	Diagrams: 637.2, 637.3, 640, 642.3, 650.3, 663, 663.1, 1062
4	Permitted variants: None
5	Illumination requirements: Schedule 17, item 12



**Status:** This is the original version (as it was originally made). This item of legislation is currently only available in its original format.

SCHEDULE 6 ROAD MARKINGS (contd.)

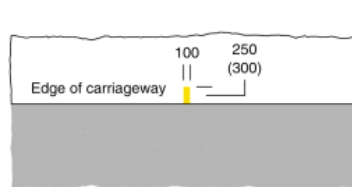

1019  
Loading and unloading of vehicles on a side of a length of road prohibited for a time less than that specified in the caption to diagram 1020.1

Item	
1	Regulations: 4
2	Directions: 7, 23, 24(1), 24(4), 25
3	Diagrams: 637.2, 638.1, 639.1B, 640, 663, 663.1
4	Permitted variants: The marking may be continued down the vertical face of a kerb at the edge of the carriageway
5	Illumination requirements: Schedule 17, item 12

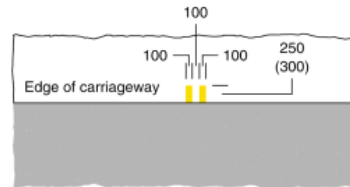

1020.1  
Loading and unloading of vehicles on a side of a length of road prohibited at any time during a period of at least 4 consecutive months

Item	
1	Regulations: 4
2	Directions: 7, 23, 24(1), 24(4), 25
3	Diagrams: 637.2, 638, 640, 663, 663.1
4	Permitted variants: Same as diagram 1019
5	Illumination requirements: Schedule 17, item 12



1022  
Approach to a road junction or level crossing at or near which is placed the sign shown in diagram 601.1 and the road marking shown in diagram 1002.1

Item	
1	Regulations: 31
2	Directions: 17, 18(3)
3	Diagrams: 601.1, 1002.1
4	Permitted variants: None
5	Illumination requirements: Schedule 17, item 12

**Status:** This is the original version (as it was originally made). This item of legislation is currently only available in its original format.

SCHEDULE 6 ROAD MARKINGS (contd.)

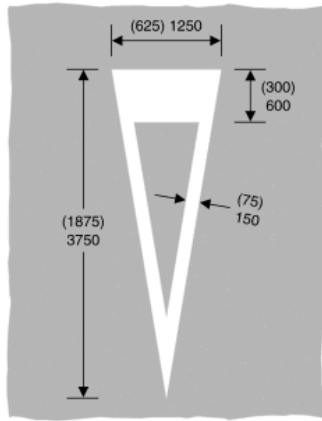

**1023**  
Approach to a road junction, level crossing or road narrowing at or near which is placed the marking shown in diagram 1003 or 1003.3

Item	
1	Regulations: 25, 31
2	Directions: 17, 18(1), 18(3), 18(5), 18(6), 34(1)
3	Diagrams: 602, 611.1, 615, 955, 956, 957, 960.1, 1003, 1003.3, 1003.4, 1009, 1057
4	Permitted variants: None
5	Illumination requirements: Schedule 17, item 12

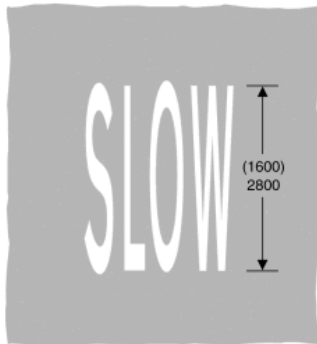

**1024**  
Vehicular traffic should proceed with caution because of potential danger ahead

Item	
1	Regulations: 31
2	Directions: None
3	Diagrams: None
4	Permitted variants: None
5	Illumination requirements: Schedule 17, item 12

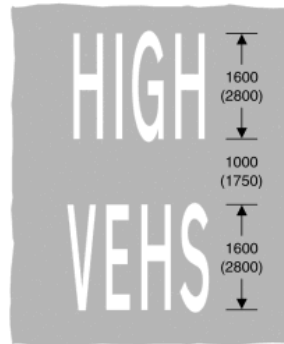

**1024.1**  
Path to be taken by high vehicles under a low bridge or to avoid an overhanging structure

Item	
1	Regulations: 31
2	Directions: 18(3)
3	Diagrams: 1010, 1014
4	Permitted variants: None
5	Illumination requirements: Schedule 17, item 12

**Status:** This is the original version (as it was originally made). This item of legislation is currently only available in its original format.

SCHEDULE 6 ROAD MARKINGS (contd.)

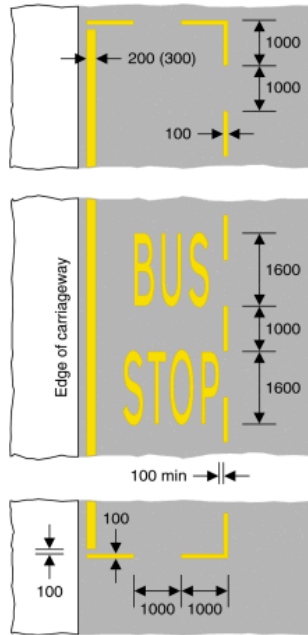

1025.1

Bus stop at which vehicular traffic must comply with the requirements of regulation 29(1) and Part I of Schedule 19

Item	
1	Regulations: 10(1), 22, 29(1)
2	Directions: 22(3), 24(1), 25
3	Diagrams: 970, 973.2, 973.3, 974, 975
4	Permitted variants: "STOP" may be varied to "STAND"
5	Illumination requirements: Schedule 17, item 12

**Status:** This is the original version (as it was originally made). This item of legislation is currently only available in its original format.

SCHEDULE 6 ROAD MARKINGS (contd.)

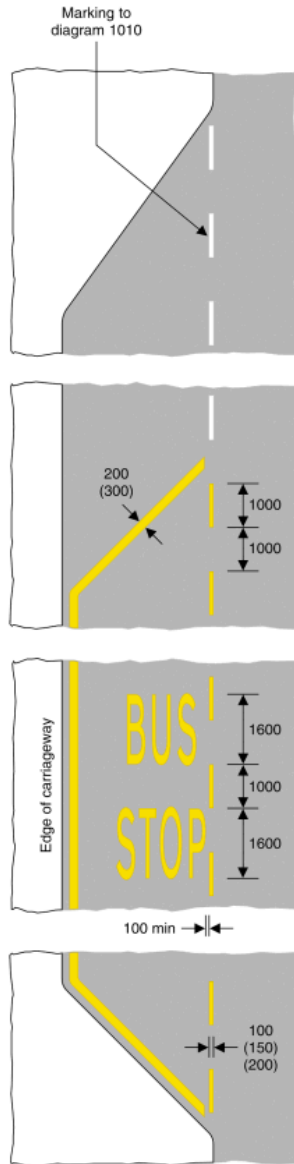

1025.3

Same as diagram 1025.1 but where the bus stop is located in part of a lay-by, the other part of which may be used by other vehicles

Item	
1	Regulations: 10(1), 22, 29(1), 31(5), 31(7)
2	Directions: 22(3), 24(1), 25
3	Diagrams: 970, 973.2, 973.3, 974, 975
4	Permitted variants: "STOP" may be varied to "STAND". The shape of the marking may be varied
5	Illumination requirements: Schedule 17, item 12

**Status:** This is the original version (as it was originally made). This item of legislation is currently only available in its original format.

SCHEDULE 6 ROAD MARKINGS (contd.)

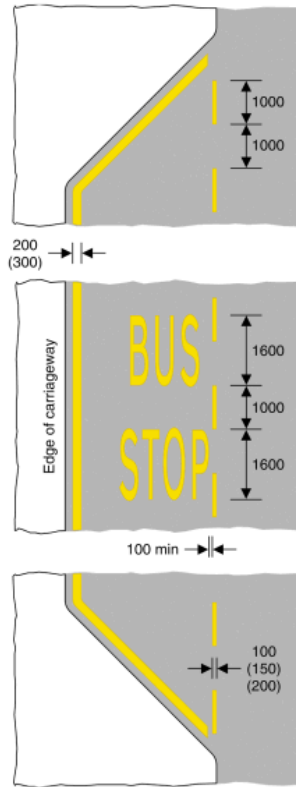

1025.4

Same as diagram 1025.1 but where the bus stop occupies the whole of a lay-by

Item	
1	Regulations: 10(1), 22, 29(1), 31(5), 31(7)
2	Directions: 22(3), 24(1), 25
3	Diagrams: 970, 973.2, 973.3, 974, 975
4	Permitted variants: Same as diagram 1025.3
5	Illumination requirements: Schedule 17, item 12

**Status:** This is the original version (as it was originally made). This item of legislation is currently only available in its original format.

SCHEDULE 6 ROAD MARKINGS (contd.)

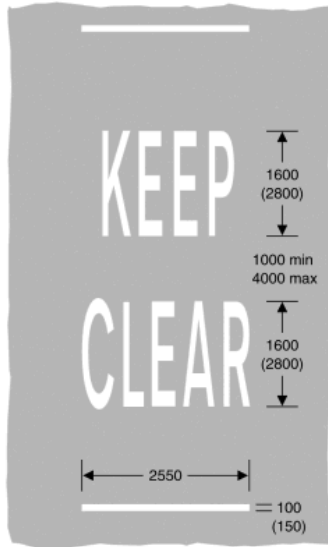

1026  
Part of the carriageway which should be kept clear of stationary vehicles

Item	
1	Regulations: None
2	Directions: None
3	Diagrams: None
4	Permitted variants: The white line indicating the extent of the area to be kept clear may be omitted
5	Illumination requirements: Schedule 17, item 12

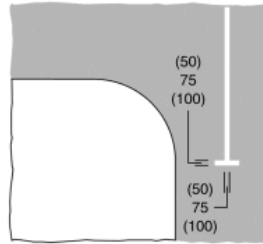
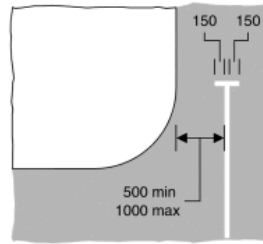

1026.1  
Part of the carriageway outside an entrance to off-street premises or a private drive, or where the kerb is dropped to provide a convenient crossing place for pedestrians, which should be kept clear of waiting vehicles

Item	
1	Regulations: None
2	Directions: None
3	Diagrams: None
4	Permitted variants: None
5	Illumination requirements: Schedule 17, item 12

**Status:** This is the original version (as it was originally made). This item of legislation is currently only available in its original format.

SCHEDULE 6 ROAD MARKINGS (contd.)

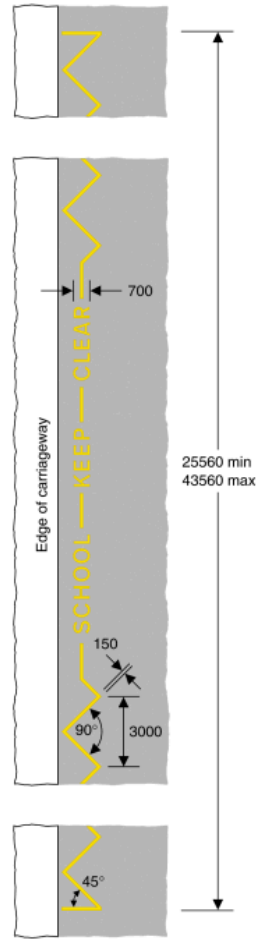

1027.1  
Part of the carriageway outside a school entrance where vehicles should not stop

Item	
1	Regulations: None
2	Directions: 22(3), 24(1)
3	Diagrams: 642.2A
4	Permitted variants: The word "SCHOOL" may be varied to "CHILDREN" and the maximum length of the marking increased to 44545 millimetres. The word "SCHOOL" shall be omitted and the minimum length of the marking reduced to 25250 millimetres when used outside a fire, police or ambulance station, or a hospital. The overall length of the marking shall be varied within the specified limits by the addition or removal of an equal number of complete zig-zag elements on each side of the legend
5	Illumination requirements: Schedule 17, Item 12

**Status:** This is the original version (as it was originally made). This item of legislation is currently only available in its original format.

SCHEDULE 6 ROAD MARKINGS (contd.)

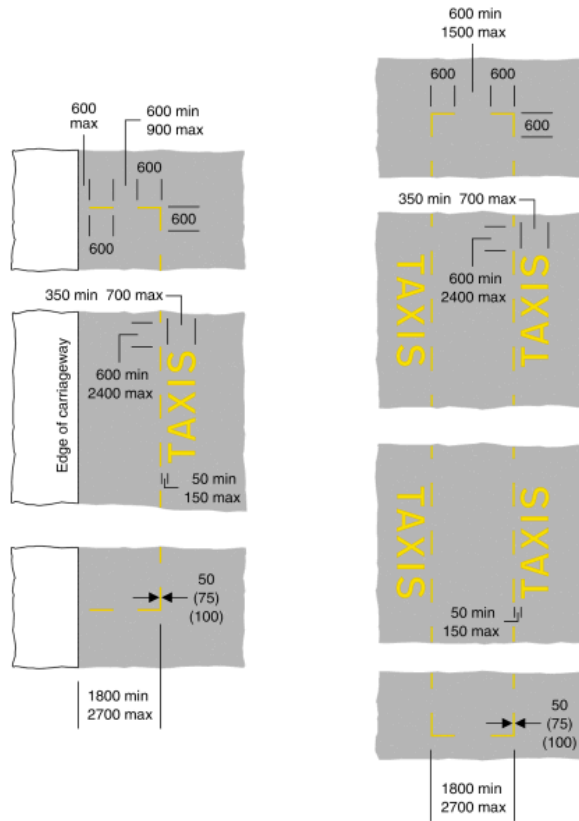

1028.2

Alternative types of taxi rank either at the edge or in the centre of the carriageway

Item	
1	Regulations: 12(6)
2	Directions: 7, 22(3), 24(1), 25
3	Diagrams: 640, 650.1, 650.2, 650.3, 857.1
4	<p>Permitted variants:                      The number of times the word "TAXIS" is shown may be varied according to the length of the marking. "TAXIS" may be varied to:</p> <ol style="list-style-type: none"> <li>1. "AMBULANCES"</li> <li>2. "POLICE"</li> </ol> <p>When the marking is used in conjunction with the sign shown in diagram 650.1, a continuous longitudinal yellow line 200 or 300 millimetres wide shall be placed along the edge of the carriageway in the manner shown in diagram 1025.1. The transverse line may be omitted when the marking is placed in a lay-by or where the end of the bay is delineated by a raised kerb</p>
5	Illumination requirements: Schedule 17, item 12



**Status:** This is the original version (as it was originally made). This item of legislation is currently only available in its original format.

SCHEDULE 6 ROAD MARKINGS (contd.)

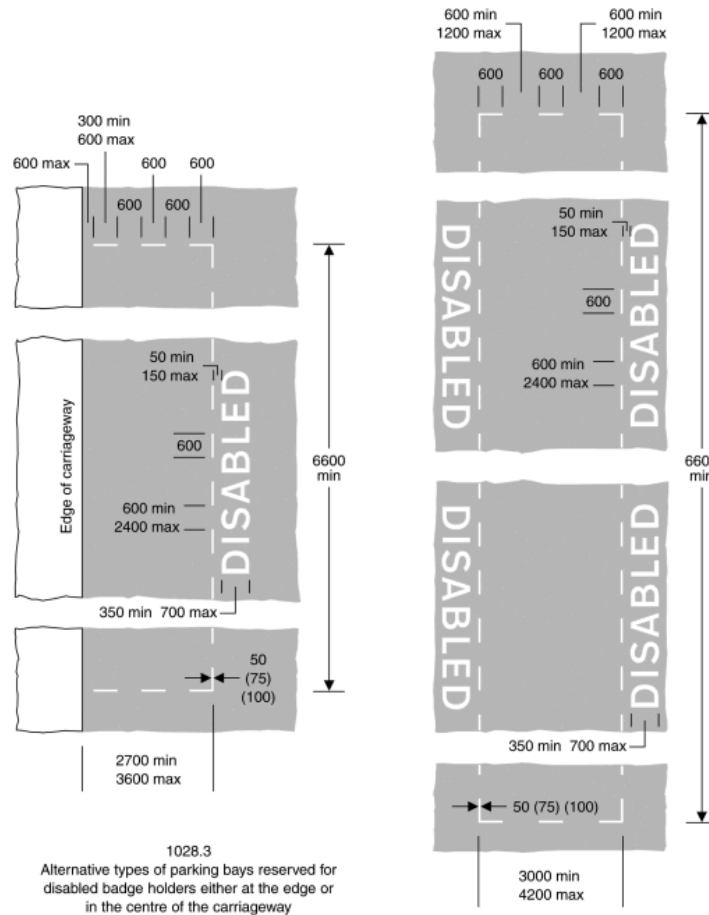

Item	
1	Regulations: 12(6), 22
2	Directions: 7, 24(1), 25
3	Diagrams: 639.1B, 660, 660.4, 661A, 661.1, 786, 801 (when used with 804.1), 969
4	Permitted variants: The number of times the word "DISABLED" is shown may be varied according to the length of the marking. "DISABLED" may be omitted or varied to: 1. "BUSES" 2. "LARGE OR SLOW VEHICLES ONLY" 3. "LOADING ONLY" The minimum width of a bay reserved for disabled badge holders at the edge of the carriageway shall be 1800 millimetres in a case where, on account of the nature of the traffic using the road, the overall width of the carriageway is insufficient to accommodate a wider bay. In such a case, or where the width of the bay is 2700 millimetres, the transverse marking shall be the same as the transverse marking in the edge of carriageway version of diagram 1028.4. The transverse line may be omitted when the marking is placed in a lay-by or where the end of the bay is delineated by a raised kerb
5	Illumination requirements: Schedule 17, item 12

**Status:** This is the original version (as it was originally made). This item of legislation is currently only available in its original format.

SCHEDULE 6 ROAD MARKINGS (contd.)

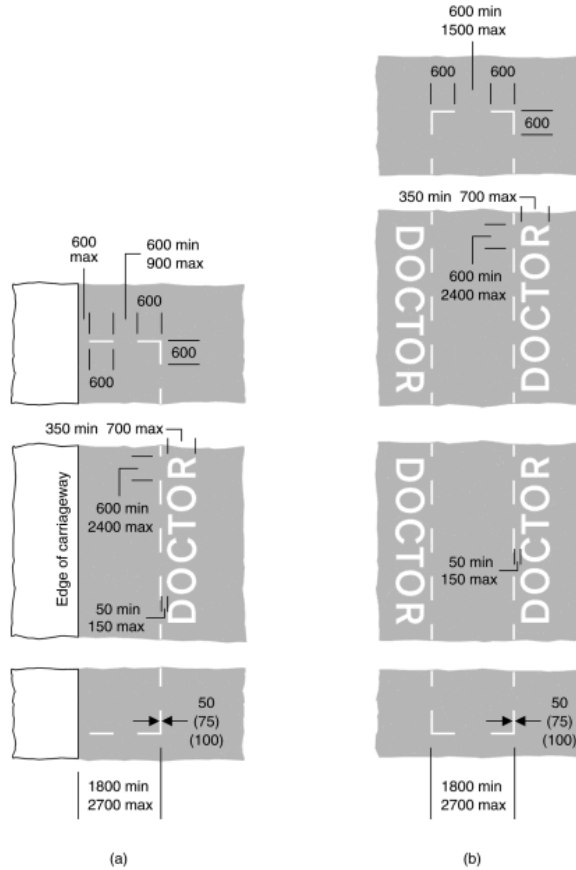

- 1028.4  
Alternative types of parking bays reserved for doctor permit holders
- (a) at the edge of the carriageway and situated wholly on either the carriageway or the footway; or
  - (b) in the centre of the carriageway or partly on the carriageway and partly on the footway

Item	
1	Regulations: 12(6)
2	Directions: 7, 24(1), 25
3	Diagrams: 639.1B, 660, 660.3, 660.5, 660.6, 660.7, 661.1, 661.2A, 661.3A, 662, 663.1, 667, 667.1, 668, 668.1, 801
4	Permitted variants: The number of times the word "DOCTOR" is shown may be varied according to the length of the marking. "DOCTOR" may be omitted or varied to: 1. "SOLO MOTORCYCLES ONLY" 2. "SOLO M/CYCLES ONLY" 3. "SOLO M/CS ONLY" 4. "PERMIT HOLDERS ONLY" The transverse line may be omitted when the marking is placed in a lay-by or where the end of the bay is delineated by a raised kerb. When the marking is placed wholly or partly on the footway any legend shall be placed only on the carriageway side of the bay
5	Illumination requirements: Schedule 17, item 12

**Status:** This is the original version (as it was originally made). This item of legislation is currently only available in its original format.

SCHEDULE 6 ROAD MARKINGS (contd.)

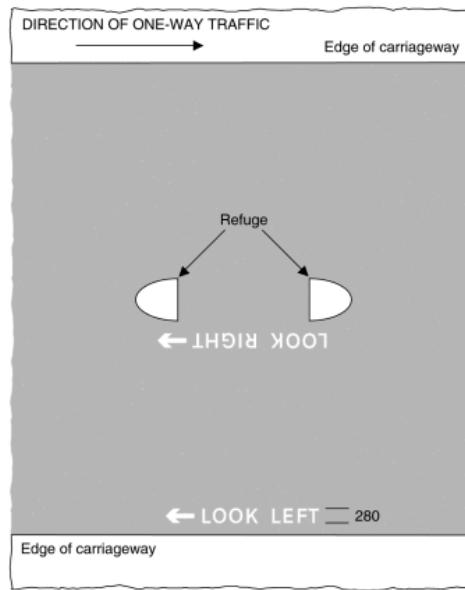

1029  
Direction in which pedestrians should  
look for approaching traffic

Item	
1	Regulations: 27(1)
2	Directions: None
3	Diagrams: None
4	Permitted variants: When used in circumstances other than shown in the diagram the marking shall be varied to accord with the direction of approaching traffic
5	Illumination requirements: Schedule 17, item 12

**Status:** This is the original version (as it was originally made). This item of legislation is currently only available in its original format.

SCHEDULE 6 ROAD MARKINGS (contd.)

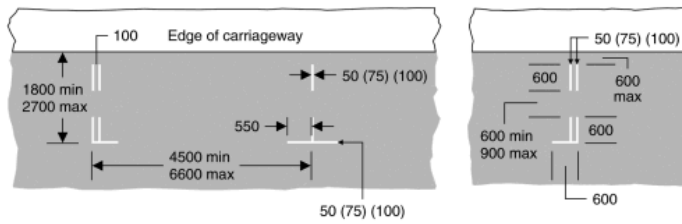

1032  
Parking bay marked with individual parking spaces  
(Longitudinal marking)

Item	
1	Regulations: 12(6)
2	Directions: 7, 24(1), 25
3	Diagrams: 639.1B, 660, 660.3, 660.4, 660.5, 660.6, 660.7, 661A, 661.1, 661.2A, 661.3A, 662, 663.1, 801
4	Permitted variants: The number of individual parking spaces may be extended as necessary. The double transverse lines are only to be used at the end of a block of parking spaces and may be omitted when the marking is placed in a lay-by or where the end of the bay is delineated by a raised kerb. Two adjacent parking spaces may be combined into a single space by omitting the transverse marks between them and giving a maximum length of space of 13200 millimetres. The words "DOCTOR", "DISABLED" or "LOADING ONLY" may be added in the manner shown in diagram 1028.4. The minimum length of a parking space reserved for disabled badge holders shall be 6600 millimetres. The width of such a space shall be 2700 millimetres but this may be reduced to a width not less than 1800 millimetres in a case where, on account of the nature of the traffic using the road, the overall width of the carriageway is insufficient to accommodate a wider bay
5	Illumination requirements: Schedule 17, item 12

**Status:** This is the original version (as it was originally made). This item of legislation is currently only available in its original format.

SCHEDULE 6 ROAD MARKINGS (contd.)

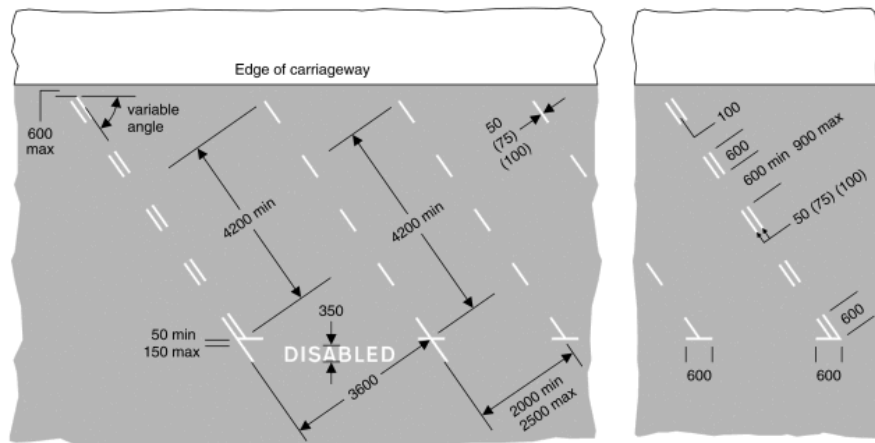

1033  
Echelon parking spaces subject to such conditions,  
if any, as may be in force

Item	
1	Regulations: 12(6)
2	Directions: 7, 24(1), 25
3	Diagrams: 639.1B, 660, 660.3, 660.4, 660.5, 660.6, 660.7, 661A, 661.1, 661.2A, 661.3A, 662, 663.1, 801
4	Permitted variants: "DISABLED" and the associated bay may be omitted. Additional "DISABLED" bays may be provided. The word "DOCTOR" may be added. The marking may be omitted along that part of a bay which is delineated by a raised kerb
5	Illumination requirements: Schedule 17, item 12

**Status:** This is the original version (as it was originally made). This item of legislation is currently only available in its original format.

SCHEDULE 6 ROAD MARKINGS (contd.)

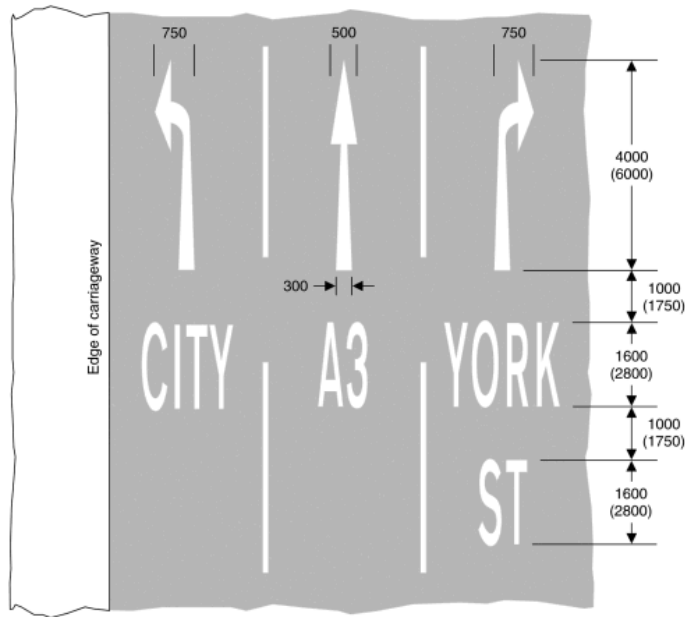

1035

Appropriate traffic lanes for different destinations

Item	
1	Regulations: 30(2), 31(5)
2	Directions: None
3	Diagrams: None
4	Permitted variants: Arrows may be omitted. The marking may be varied in accordance with regulation 30(2)
5	Illumination requirements: Schedule 17, item 12

**Status:** This is the original version (as it was originally made). This item of legislation is currently only available in its original format.

SCHEDULE 6 ROAD MARKINGS (contd.)

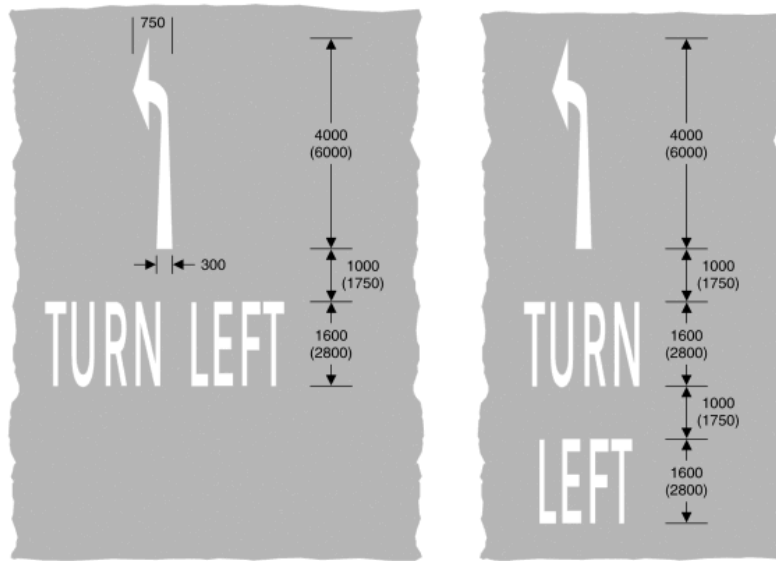

1036.1  
Vehicular traffic must turn left  
(Alternative types)

Item	
1	Regulations: 31
2	Directions: 7
3	Diagrams: None
4	Permitted variants: None
5	Illumination requirements: Schedule 17, item 12

**Status:** This is the original version (as it was originally made). This item of legislation is currently only available in its original format.

SCHEDULE 6 ROAD MARKINGS (contd.)

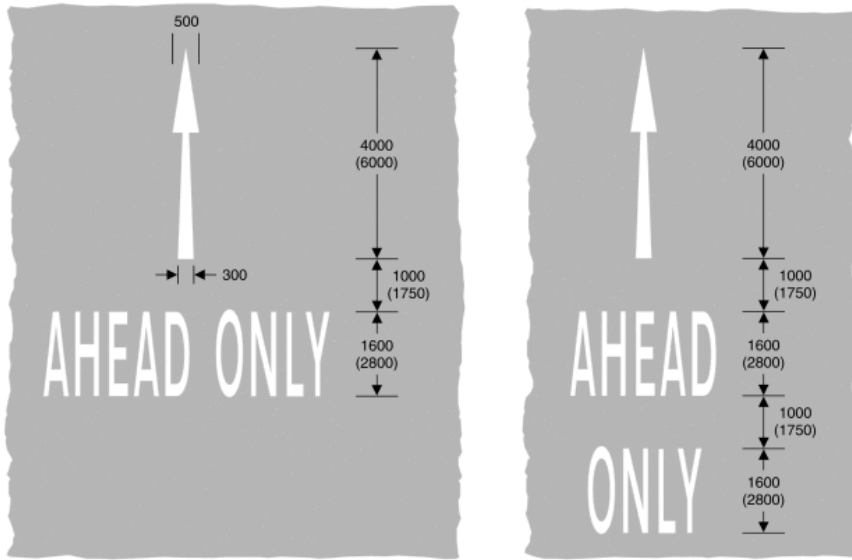

1036.2  
Vehicular traffic must only proceed ahead  
(Alternative types)

Item	
1	Regulations: 31
2	Directions: 7
3	Diagrams: None
4	Permitted variants: None
5	Illumination requirements: Schedule 17, Item 12



**Status:** This is the original version (as it was originally made). This item of legislation is currently only available in its original format.

SCHEDULE 6 ROAD MARKINGS (contd.)

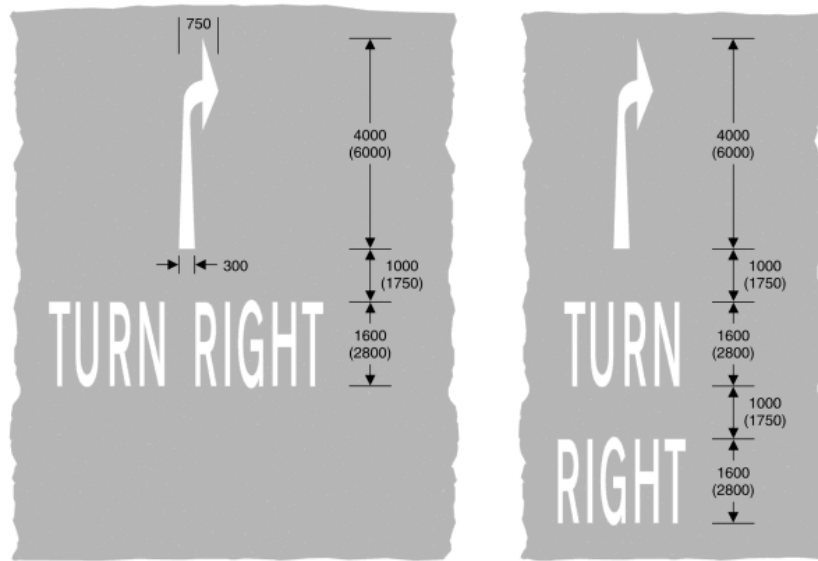

1037.1  
Vehicular traffic must turn right  
(Alternative types)

Item	
1	Regulations: 31
2	Directions: 7
3	Diagrams: None
4	Permitted variants: None
5	Illumination requirements: Schedule 17, item 12

**Status:** This is the original version (as it was originally made). This item of legislation is currently only available in its original format.

SCHEDULE 6 ROAD MARKINGS (contd.)

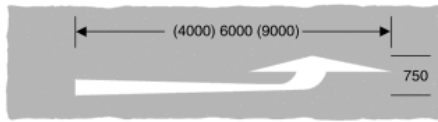

1038  
Appropriate traffic lanes for different manoeuvres  
(Longitudinal marking)

Item	
1	Regulations: None
2	Directions: None
3	Diagrams: None
4	Permitted variants: Direction of the arrow heads may be varied, but no arrow shall show more than two directions
5	Illumination requirements: Schedule 17, item 12

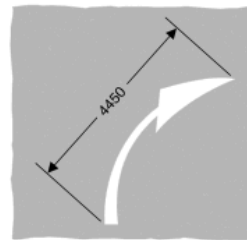
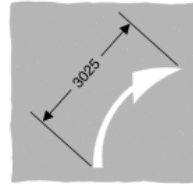

1038.1  
Appropriate direction to be taken  
by traffic turning within a junction  
(Alternative types)

Item	
1	Regulations: None
2	Directions: None
3	Diagrams: None
4	Permitted variants: The curvature of the arrow may be varied
5	Illumination requirements: Schedule 17, item 12

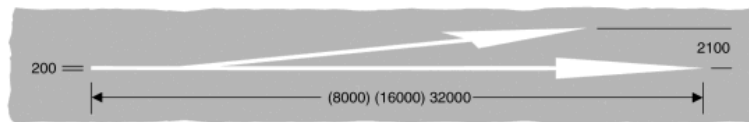

1039  
Place where traffic streams divide or bifurcate  
(Longitudinal marking)

Item	
1	Regulations: 31
2	Directions: None
3	Diagrams: None
4	Permitted variants: Schedule 16, item 28
5	Illumination requirements: Schedule 17, item 12

**Status:** This is the original version (as it was originally made). This item of legislation is currently only available in its original format.

SCHEDULE 6 ROAD MARKINGS (contd.)

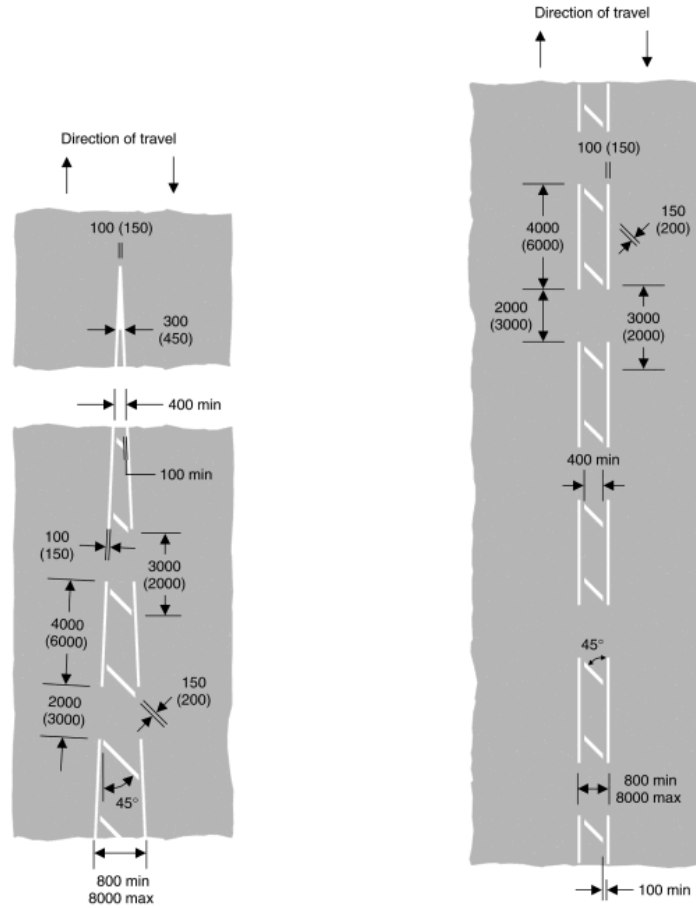

1040  
Part of the carriageway which vehicular traffic should not enter unless it is seen by the driver to be safe to do so

1040.2  
Length of road along which drivers should not overtake by passing through the marking unless it is seen by the driver to be safe to do so

Item	
1	Regulations: 4, 12(4), 31
2	Directions: None
3	Diagrams: 1014
4	Permitted variants: One of the boundary lines shall be omitted when the marking is placed alongside diagram 1049 denoting a bus lane or cycle lane
5	Illumination requirements: Schedule 17, item 12

Item	
1	Regulations: 4, 12(4), 31
2	Directions: None
3	Diagrams: None
4	Permitted variants: Same as diagram 1040
5	Illumination requirements: Schedule 17, item 12

**Status:** This is the original version (as it was originally made). This item of legislation is currently only available in its original format.

SCHEDULE 6 ROAD MARKINGS (contd.)

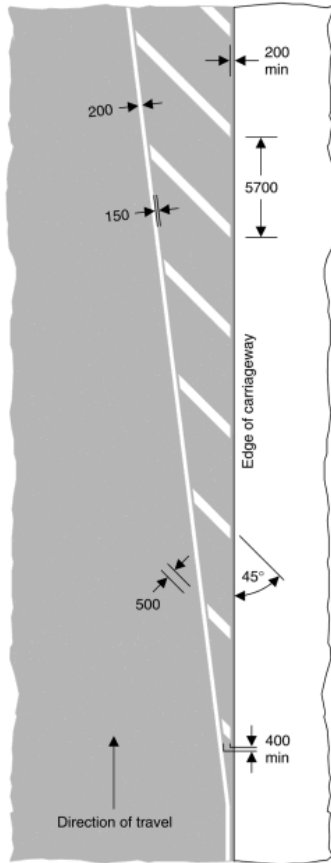

1040.3

Reduction in number of lanes, or area not available to traffic, on the main carriageway or slip road of a motorway or all-purpose dual carriageway road

Item	
1	Regulations: 31
2	Directions: None
3	Diagrams: 1014
4	Permitted variants: The width of the longitudinal line may be varied to 150 millimetres when used on an all-purpose road without hard shoulders. The boundary line may be replaced by the marking shown in diagram 1012.2 or 1012.3 as appropriate
5	Illumination requirements: Schedule 17, item 12

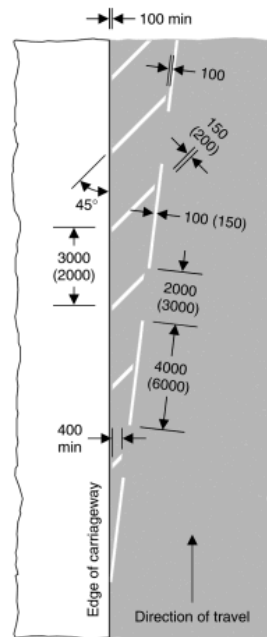

1040.4

Part of the carriageway adjacent to the edge which vehicular traffic should not enter unless it is seen by the driver to be safe to do so

Item	
1	Regulations: 12(4), 31
2	Directions: None
3	Diagrams: 1014
4	Permitted variants: The boundary to the left of the hatched area may be formed by the marking shown in diagram 1049 denoting the off side edge of a cycle lane. The angle of the hatching shall be reversed when the marking is used on the off side of the carriageway
5	Illumination requirements: Schedule 17, item 12

**Status:** This is the original version (as it was originally made). This item of legislation is currently only available in its original format.

SCHEDULE 6 ROAD MARKINGS (contd.)

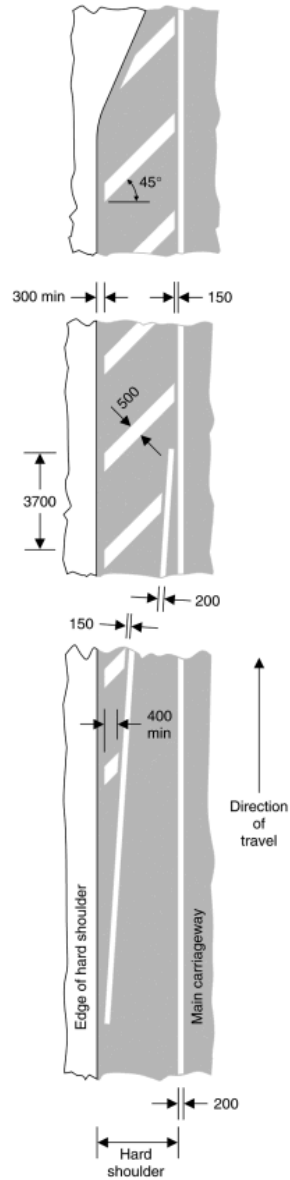

1040.5  
End of hard shoulder

Item	
1	Regulations: 31
2	Directions: None
3	Diagrams: None
4	Permitted variants: The boundary line and edge of carriageway line may be replaced by the marking shown in either diagram 1012.2 or diagram 1012.3 varied to 200 millimetres wide, as appropriate
5	Illumination requirements: Schedule 17, item 12

**Status:** This is the original version (as it was originally made). This item of legislation is currently only available in its original format.

SCHEDULE 6 ROAD MARKINGS (contd.)

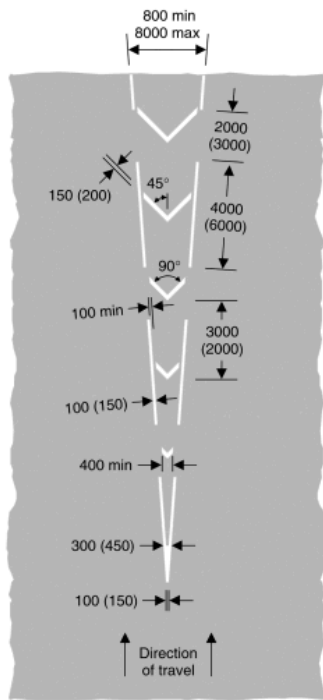

1041

Part of the carriageway where vehicular traffic passes in the same direction on both sides of the marking, and should not enter the area covered by the marking unless it is seen by the driver to be safe to do so

Item	
1	Regulations: 4, 12(4), 31
2	Directions: None
3	Diagrams: None
4	Permitted variants: The direction of the chevrons shall be reversed when the direction of travel is in the opposite direction. One of the boundary lines shall be omitted when the marking is placed alongside diagram 1049 denoting a bus lane or cycle lane
5	Illumination requirements: Schedule 17, item 12

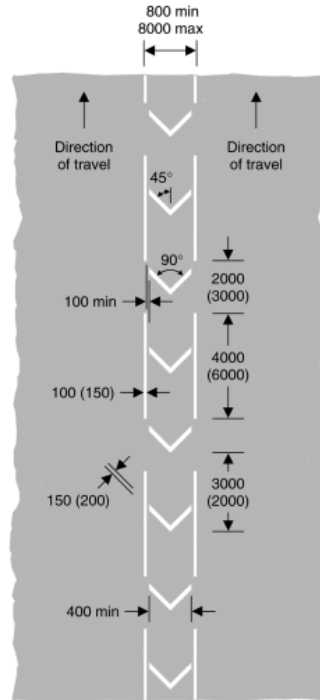

1041.1

Length of road along which vehicular traffic travels in the same direction on both sides of the marking, and should not enter the area covered by the marking unless it is seen by the driver to be safe to do so

Item	
1	Regulations: 4, 12(4), 31
2	Directions: None
3	Diagrams: None
4	Permitted variants: Same as diagram 1041
5	Illumination requirements: Schedule 17, item 12

**Status:** This is the original version (as it was originally made). This item of legislation is currently only available in its original format.

SCHEDULE 6 ROAD MARKINGS (contd.)

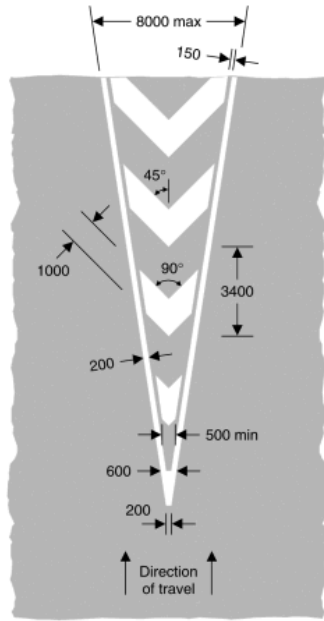

1042

Part of the verge or hard shoulder on a motorway or all-purpose dual carriageway road between the main carriageway of a motorway or all-purpose dual carriageway road and the carriageway of a slip road, or at the bifurcation or convergence of motorways or all-purpose dual carriageway roads, or part of a carriageway between two lanes at a roundabout which vehicular traffic must not enter except in an emergency

Item	
1	Regulations: 4, 10(1), 31
2	Directions: None
3	Diagrams: None
4	Permitted variants: The direction of the chevrons shall be reversed when the direction of travel is in the opposite direction. The width of the longitudinal lines may be varied to 150 millimetres when the marking is used between two lanes at a roundabout or on an all-purpose dual carriageway road without hard shoulders. Except at a roundabout, the boundary lines may be replaced by the marking shown in either diagram 1012.2 or diagram 1012.3 as appropriate
5	Illumination requirements: Schedule 17, item 12

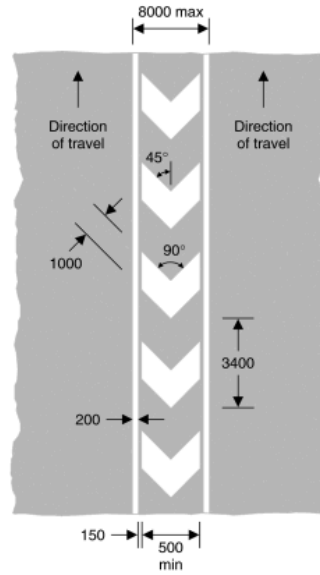

1042.1

Division of traffic lanes on a length of carriageway, or between the main carriageway and slip road, of a motorway or all-purpose dual carriageway road, or part of a carriageway between two lanes at a roundabout which vehicular traffic must not enter except in an emergency

Item	
1	Regulations: 4, 10(1), 31
2	Directions: None
3	Diagrams: None
4	Permitted variants: Same as diagram 1042
5	Illumination requirements: Schedule 17, item 12

**Status:** This is the original version (as it was originally made). This item of legislation is currently only available in its original format.

SCHEDULE 6 ROAD MARKINGS (contd.)

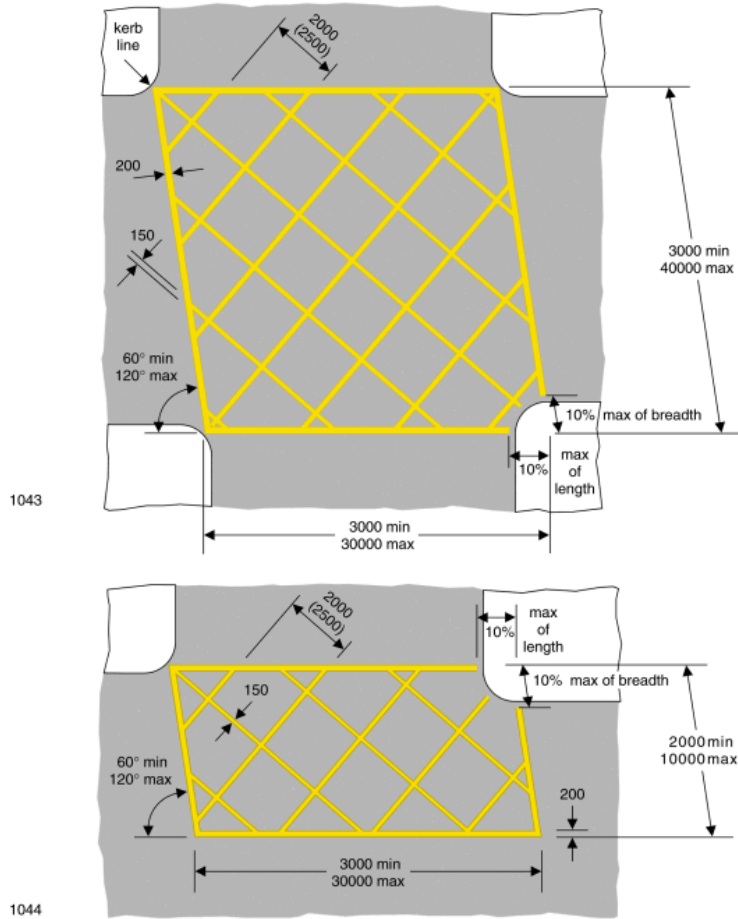

1043, 1044  
Marking conveying the requirements prescribed by regulation 29(2) and Part II of Schedule 19

Item	
1	Regulations: 10(1), 12(6), 12(11), 29(2)
2	Directions: 35
3	Diagrams: 615, 811
4	Permitted variants: Any corner may be cut away as shown. The cut-away corner may be completed in the same manner as the other corners. Parts of the marking shall be omitted where tram rails cross the marking. Parts of the marking may be omitted to indicate the edge of the path taken by a tramcar and, where so omitted, the remaining parts shall be bounded by a continuous yellow line
5	Illumination requirements: Schedule 17, item 12



**Status:** This is the original version (as it was originally made). This item of legislation is currently only available in its original format.

SCHEDULE 6 ROAD MARKINGS (contd.)

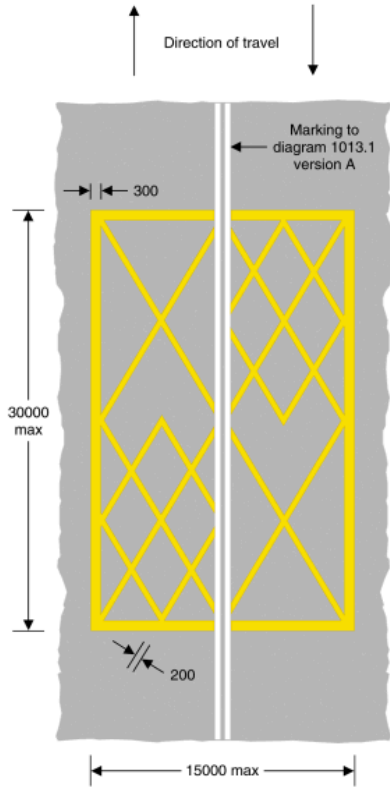

1045  
Area of carriageway at a level crossing which vehicles must not enter in a manner which then causes any part of the vehicle to remain at rest within the marked area due to the presence of stationary vehicles (Shown in combination with diagram 1013.1 version A)

Item	
1	Regulations: 10(1), 12(6)
2	Directions: 18(1)
3	Diagrams: 1013.1 (version A)
4	Permitted variants: The pattern of diagonal lines on each side of the level crossing may be extended longitudinally within the specified limit by increasing the number of diamond shapes on the approach side and the number of diagonal crosses on the leaving side
5	Illumination requirements: Schedule 17, item 12

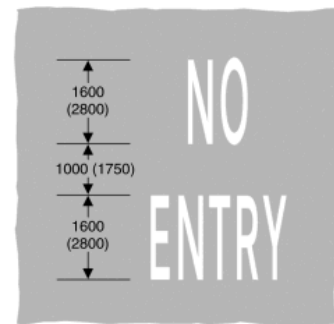

1046  
No entry for vehicular traffic (Alternative types)

Item	
1	Regulations: 31
2	Directions: 7
3	Diagrams: 616, and when the marking is varied to "PLAY STREET", 617 with 618
4	Permitted variants: "NO ENTRY" may be varied to "PLAY STREET"
5	Illumination requirements: Schedule 17, item 12

**Status:** This is the original version (as it was originally made). This item of legislation is currently only available in its original format.

SCHEDULE 6 ROAD MARKINGS (contd.)

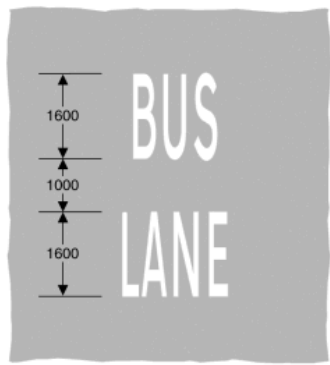

1048

With-flow lane reserved for buses and other vehicles as indicated on the sign shown in diagram 959 or a contra-flow lane reserved for buses

Item	
1	Regulations: 22, 23
2	Directions: 7, 17, 18(3)
3	Diagrams: 959, 960, 1049
4	Permitted variants: None
5	Illumination requirements: Schedule 17, item 12

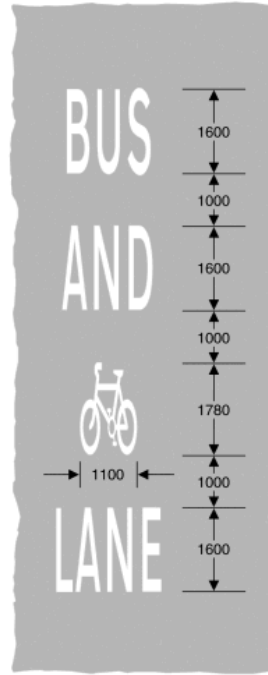

1048.1

Contra-flow lane reserved for buses and pedal cycles

Item	
1	Regulations: 22, 23
2	Directions: 7, 17, 18(3)
3	Diagrams: 960 (when varied to include the cycle symbol), 1049
4	Permitted variants: None
5	Illumination requirements: Schedule 17, item 12

**Status:** This is the original version (as it was originally made). This item of legislation is currently only available in its original format.

SCHEDULE 6 ROAD MARKINGS (contd.)

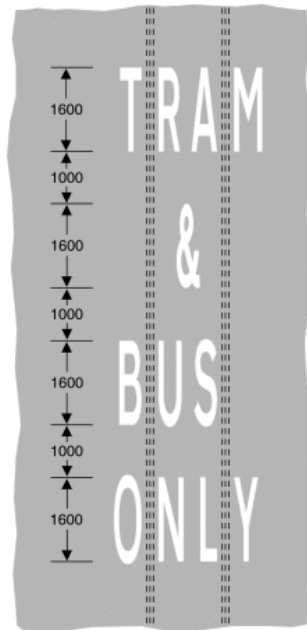

1048.2  
Road or part of a road with access permitted only for buses and trams

Item	
1	Regulations: 22
2	Directions: 7, 18(1)
3	Diagrams: 953.1
4	Permitted variants: "& BUS" may be omitted
5	Illumination requirements: Schedule 17, item 12



1048.3  
Road or part of a road with access permitted only for buses  
(Alternative types)

Item	
1	Regulations: 22
2	Directions: 7, 18(4)
3	Diagrams: 616 (when used with 954 or 954.2), 953 (when varied to show only the bus symbol)
4	Permitted variants: None
5	Illumination requirements: Schedule 17, item 12

**Status:** This is the original version (as it was originally made). This item of legislation is currently only available in its original format.

SCHEDULE 6 ROAD MARKINGS (contd.)

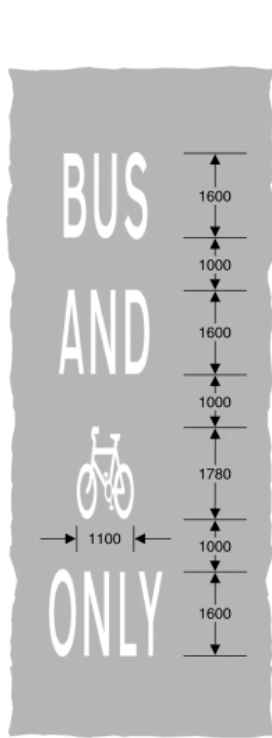

1048.4  
Road or part of a road with access permitted only for buses and pedal cycles

Item	
1	Regulations: 22
2	Directions: 7, 18(1)
3	Diagrams: 953
4	Permitted variants: "AND" or the cycle symbol may be varied to "TAXI". The legend may be on two or three lines in which case "AND" may be varied to "&."
5	Illumination requirements: Schedule 17, item 12



1049  
Boundary of a bus lane, cycle lane, cycle track or route used by pedal cycles and pedestrians only. Where used in conjunction with the sign shown in diagram 957, the division of a route into that part reserved for pedal cycles and that part reserved for pedestrians

Item	
1	Regulations: 4, 31
2	Directions: 7, 17, 18(3), 18(5), 33
3	Diagrams: 955, 956, 957, 959, 959.1, 960, 960.1, 1010, 1014, 1048, 1048.1, 1050, 1057, 1058
4	Permitted variants: None
5	Illumination requirements: Schedule 17, item 12

**Status:** This is the original version (as it was originally made). This item of legislation is currently only available in its original format.

SCHEDULE 6 ROAD MARKINGS (contd.)

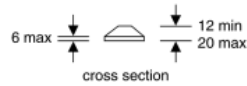
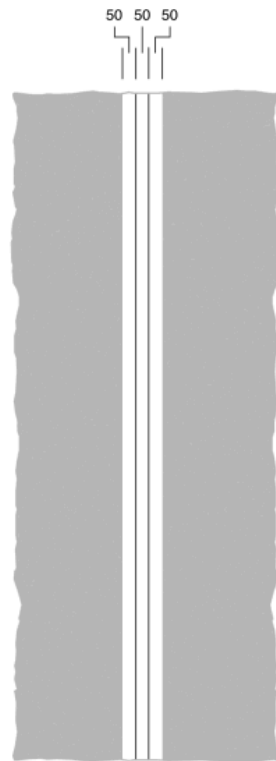

1049.1  
Division of a route into that part reserved for pedal cycles and that part reserved for pedestrians

Item	
1	Regulations: 11(2), 32(2)
2	Directions: 7, 18(3), 33
3	Diagrams: 957, 1057, 1058
4	Permitted variants: None
5	Illumination requirements: Schedule 17, item 12

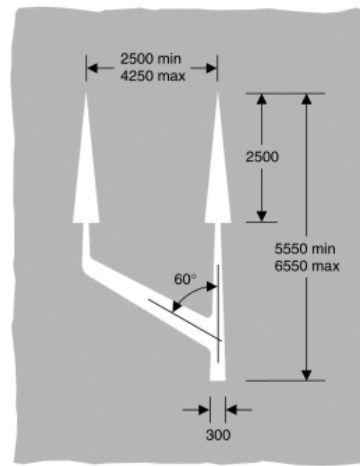

1050  
Direction of possible traffic movements at the end of a bus lane

Item	
1	Regulations: 12(6)
2	Directions: 7, 18(3)
3	Diagrams: 964, 1049
4	Permitted variants: The left hand arrow head may indicate a left turn in the manner shown in diagram 1036.1
5	Illumination requirements: Schedule 17, item 12

**Status:** This is the original version (as it was originally made). This item of legislation is currently only available in its original format.

SCHEDULE 6 ROAD MARKINGS (contd.)

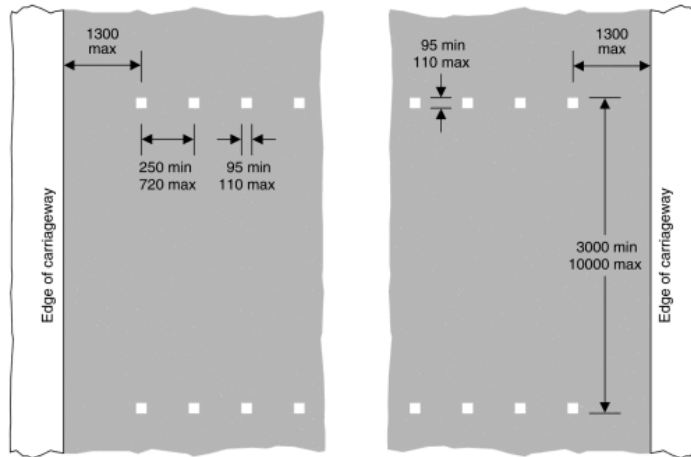

1055.1

- (a) Place suitable for pedestrians to cross a road at which traffic is subject to control by a constable in uniform or by a traffic warden, being control which is normally in operation during periods amounting in aggregate to not less than 20 hours in any week; or
- (b) the most suitable place for pedestrians to cross a carriageway within 10 metres of traffic light signals of the kind prescribed by regulation 33(1); or
- (c) place suitable for cyclists to cross a road at which cyclists are controlled by traffic light signals of the kind prescribed by regulation 33(2) and other vehicular traffic is controlled by traffic light signals of the kind prescribed by regulation 33(1); or
- (d) signal controlled pedestrian facility; or
- (e) Toucan crossing; or
- (f) equestrian only crossing

Item	
1	Regulations: 4, 11(4), 12(6)
2	Directions: 18(1)
3	Diagrams: 1001, 1001.3, 3000, 3000.2, 3000.7, 3000.8, 3000.9, 3000.10, 4002.1, 4003.1, 4003.2, 4003.4, 4003.5, 4003.7
4	Permitted variants: The square marks may be varied to circular marks with a diameter between 95 mm and 110 mm. The number of marks shall be varied according to the width of the road. The minimum width of a crossing, other than a Toucan crossing, may be reduced from 3000 mm to 2400 mm
5	Illumination requirements: Schedule 17, item 12

**Status:** This is the original version (as it was originally made). This item of legislation is currently only available in its original format.

SCHEDULE 6 ROAD MARKINGS (contd.)

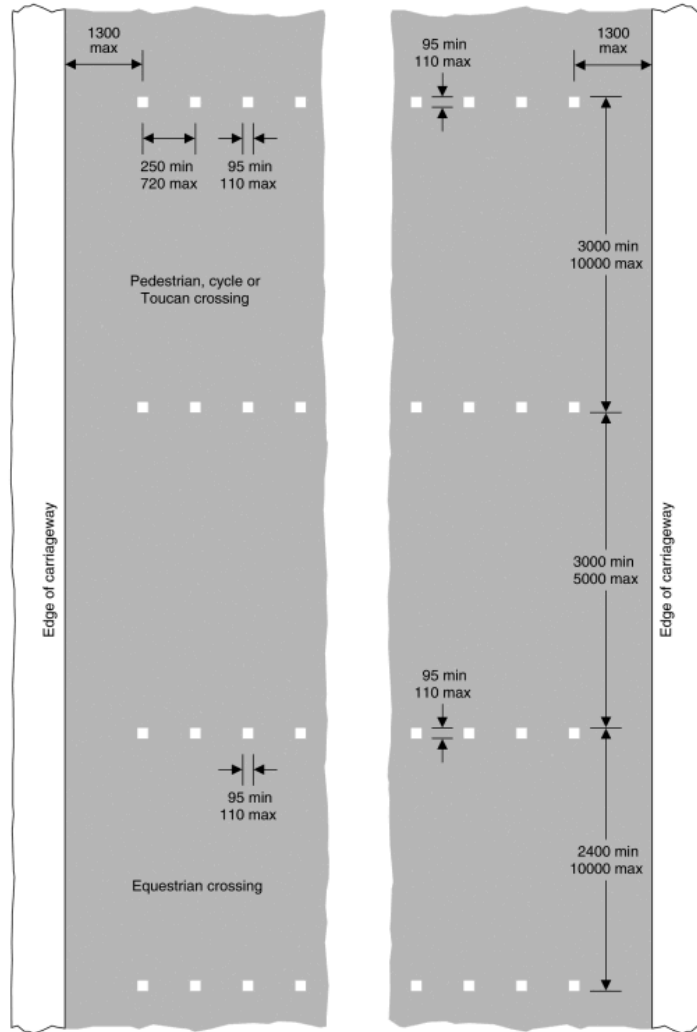

1055.2  
Same as diagram 1055.1 (c), (d) or (e) with an additional crossing point for equestrians

Item	
1	Regulations: 4, 11(4), 12(6)
2	Directions: 18(1)
3	Diagrams: 1001, 1001.3, 3000, 3000.2, 3000.7, 3000.8, 3000.9, 3000.10, 4002.1, 4003.1, 4003.2, 4003.4, 4003.5, 4003.7
4	Permitted variants: Same as diagram 1055.1
5	Illumination requirements: Schedule 17, item 12

**Status:** This is the original version (as it was originally made). This item of legislation is currently only available in its original format.

SCHEDULE 6 ROAD MARKINGS (contd.)

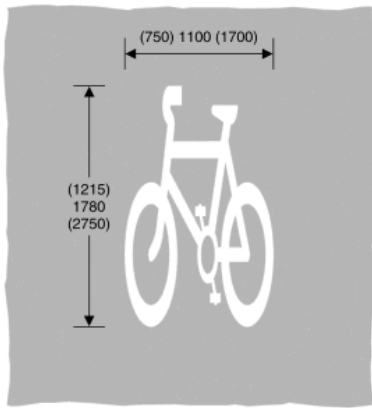

1057  
Cycle lane, track or route

Item	
1	Regulations: None
2	Directions: 17, 18(1), 18(3), 18(5)
3	Diagrams: 955, 956, 957, 959.1, 960.1, 965, 967, 1001.2, 1003, 1004, 1004.1, 1023, 1049, 1049.1, 1058, 1059, 2601.2, 2602.2
4	Permitted variants: Schedule 16, item 28
5	Illumination requirements: Schedule 17, item 12

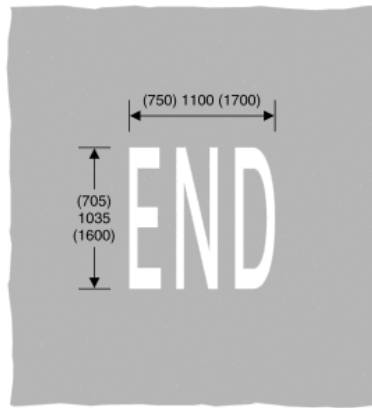

1058  
End of cycle lane, track or route

Item	
1	Regulations: None
2	Directions: 18(1)
3	Diagrams: 965, 1049, 1049.1, 1057
4	Permitted variants: None
5	Illumination requirements: Schedule 17, item 12

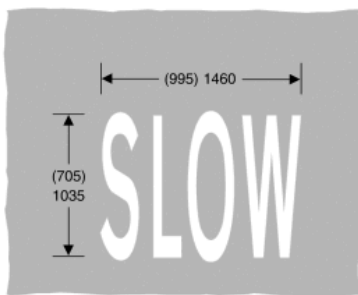

1058.1  
Pedal cycles should proceed with caution because of potential danger ahead

Item	
1	Regulations: None
2	Directions: None
3	Diagrams: None
4	Permitted variants: None
5	Illumination requirements: Schedule 17, item 12



**Status:** This is the original version (as it was originally made). This item of legislation is currently only available in its original format.

SCHEDULE 6 ROAD MARKINGS (contd.)

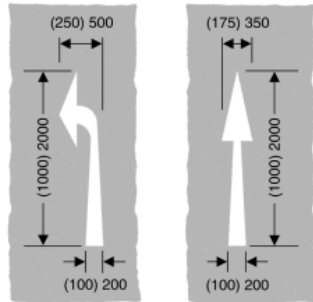

1059  
Directions in which pedal cycles should travel on a cycle lane, track or route

Item	
1	Regulations: None
2	Directions: 18(1)
3	Diagrams: 1057
4	Permitted variants: The arrow pointing to the left may be reversed to point to the right
5	Illumination requirements: Schedule 17, item 12

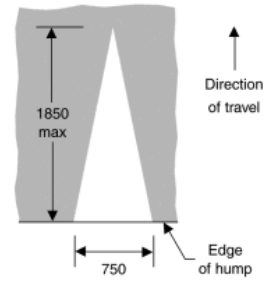

1062  
Road hump

Item	
1	Regulations: 27(1), 31
2	Directions: 17, 18(1)
3	Diagrams: 557.1, 1004, 1012.1, 1017, 1018.1
4	Permitted variants: None
5	Illumination requirements: Schedule 17, item 12

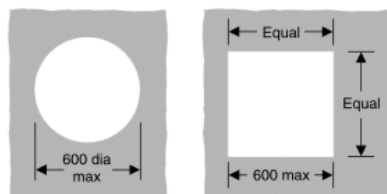

1063  
Limits of a measured length of road for assessing the speed of vehicular traffic (Alternative types)

Item	
1	Regulations: None
2	Directions: 39(4)
3	Diagrams: None
4	Permitted variants: None
5	Illumination requirements: Schedule 17, item 12

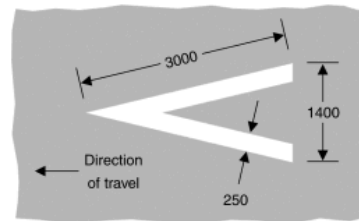

1064  
Chevron marking for use in conjunction with the sign shown in diagram 2933

Item	
1	Regulations: 31
2	Directions: 14(1), 17, 18(1), 18(7)
3	Diagrams: 2933, 2934
4	Permitted variants: None
5	Illumination requirements: Schedule 17, item 12

**Status:** This is the original version (as it was originally made). This item of legislation is currently only available in its original format.

SCHEDULE 6 ROAD MARKINGS (contd.)

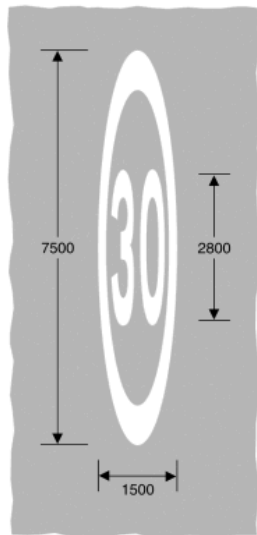
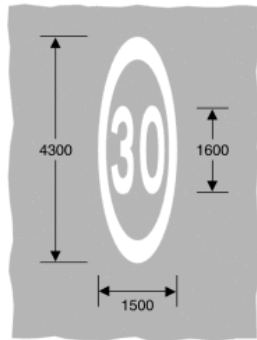

1065  
Maximum speed limit  
(Alternative sizes)

Item	
1	Regulations: 31
2	Directions: 7, 18(1)
3	Diagrams: 670, 674
4	Permitted variants: "30" may be varied to "20", "40" or "50", or, when used on a dual carriageway road only, to "60"
5	Illumination requirements: Schedule 17, item 12

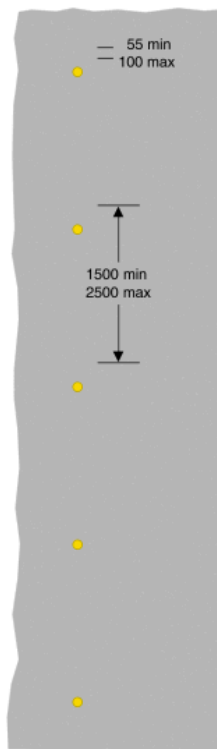

1066  
Edge of part of the road used by tramcars

Item	
1	Regulations: 12(6)
2	Directions: None
3	Diagrams: None
4	Permitted variants: None
5	Illumination requirements: Schedule 17, item 12