

Commission Decision of 20 March 2006 on the detailed technical requirements for carrying out the tests specified in Directive 2005/66/EC of the European Parliament and of the Council relating to the use of frontal protection systems on motor vehicles (notified under document number C(2006) 776) (Text with EEA relevance) (2006/368/EC)

COMMISSION DECISION

of 20 March 2006

on the detailed technical requirements for carrying out the tests specified in Directive 2005/66/EC of the European Parliament and of the Council relating to the use of frontal protection systems on motor vehicles

(notified under document number C(2006) 776)

(Text with EEA relevance)

(2006/368/EC)

THE COMMISSION OF THE EUROPEAN COMMUNITIES,

Having regard to the Treaty establishing the European Community,

Having regard to Directive 2005/66/EC of the European Parliament and of the Council relating to the use of frontal protection systems on motor vehicles and amending Council Directive 70/156/EEC⁽¹⁾, and in particular Article 4(1) thereof,

Whereas:

- (1) Directive 2005/66/EC sets out the basic requirements for the Community type-approval of motor vehicles with regard to the use of frontal protection systems and the type-approval of frontal protection systems as separate technical units.
- (2) It is necessary to lay down the detailed technical requirements for the tests laid down in Section 3 of Annex I to that Directive.
- (3) Since those tests are based on the scientific work performed by the European Enhanced Vehicle Safety Committee (EEVC), the detailed technical requirements should also be based on the EEVC recommendations.
- (4) In order to ensure the safety of pedestrians and other road users, it should be possible for a frontal protection system which has been designed for more than one vehicle type to be type-approved separately for every type. However, the test authority should be able to waive additional tests in cases where the vehicle types for which the frontal protection system is intended are sufficiently similar, or the frontal protection system is sufficiently similar to models which have already been tested.
- (5) The measures provided for in this Decision are in accordance with the opinion of the Committee established under Directive 70/156/EC,

Changes to legislation: There are currently no known outstanding effects for the Commission Decision of 20 March 2006 on the detailed technical requirements for carrying out the tests specified in Directive 2005/66/EC of the European Parliament and of the Council relating to the use of frontal protection systems on motor vehicles (notified under document number C(2006) 776) (Text with EEA relevance) (2006/368/EC). (See end of Document for details)

HAS ADOPTED THIS DECISION:

Article 1 **U.K.**

1 The detailed technical requirements necessary to carry out the tests relating to the use of frontal protection systems as original equipment fitted to a motor vehicle and as separate technical units, specified in Section 3 of Annex I to Directive 2005/66/EC, are laid down in the Annex to this Decision.

2 Where, in the case of the tests for type approval of a frontal protection system as original equipment fitted to a vehicle, the system to be tested has been designed for use on more than one vehicle type, that system shall be type-approved separately for every vehicle type for which it is intended.

However, the test authority shall have the power to waive additional tests where the intended vehicle types or the frontal protection system models are considered to be sufficiently similar.

Article 2 **U.K.**

This Decision shall apply from 26 November 2006.

Article 3 **U.K.**

This Decision is addressed to the Member States.

Done at Brussels, 20 March 2006.

For the Commission

GÜNTER VERHEUGEN

Member of the Commission

Changes to legislation: There are currently no known outstanding effects for the Commission Decision of 20 March 2006 on the detailed technical requirements for carrying out the tests specified in Directive 2005/66/EC of the European Parliament and of the Council relating to the use of frontal protection systems on motor vehicles (notified under document number C(2006) 776) (Text with EEA relevance) (2006/368/EC). (See end of Document for details)

ANNEX **U.K.**PART I **U.K.**1. DEFINITIONS **U.K.**

In addition to the definitions set out in Article 2 of Directive 2005/66/EC of the European Parliament and the Council and in Section 1 of Annex I thereto, the following shall apply:

- 1.1. ‘*Ground reference level*’ means the horizontal plane parallel to the ground level, representing the ground level for a vehicle placed at rest on a flat surface with the hand brake on and the vehicle positioned in its normal ride attitude.
- 1.2. ‘*Corner of frontal protection system*’ means the frontal protection system’s point of contact with a vertical plane, which makes an angle of 60° with the vertical longitudinal plane of the vehicle and is tangential to the outer surface of the frontal protection system. The bottom edge of the plane must be at ground reference level, as described in paragraph 1.1, and the top edge at a height of 600 mm. (see Figure 5).
- 1.3. ‘*Third of the frontal protection system*’ means the geometric trace between the corners of the frontal protection system, measured with a flexible tape following the outer horizontal contour of the frontal protection system, divided into three equal parts.
- 1.4. ‘*Frontal protection system leading edge*’ means the uppermost outer structure of the frontal protection system and excludes the vehicle bonnet and wings, the upper and side members of the headlight surround and any other attachments such as grills protecting only lights (see Figure 4).
- 1.5. ‘*Frontal protection system leading edge height*’ for any section of the frontal protection system means the vertical distance between the ground reference level and the frontal protection system leading edge reference line, with the vehicle positioned in its normal ride attitude.
- 1.6. ‘*Frontal protection system lead*’ for any point on a frontal protection system means the horizontal distance between the upper frontal protection system reference line and the position of the point being considered on the frontal protection system. This distance must be measured on a vertical plane parallel to the vertical longitudinal plane of the vehicle.
- 1.7. ‘*Corner of frontal protection system leading edge*’ means the frontal protection system’s point of contact with a vertical plane which makes an angle of 45° with the vertical longitudinal plane of the vehicle and is tangential to the outer surface of the frontal protection system. The bottom edge of the plane must be at a height of 600 mm, or 200 mm below the highest part of the frontal protection system, whichever is the higher.
- 1.8. ‘*Third of the frontal protection system leading edge*’ means the geometric trace between the corners of the frontal protection system upper leading edge measured with a flexible tape following the horizontal outer contour of the frontal protection system, divided into three equal parts.
- 1.9. ‘*Frontal protection system wrap around distance*’ of any point on the frontal protection system means the distance to that point measured by a flexible tape held in a vertical fore and aft plane of the vehicle. The tape is held taut with one end in contact with that point and the other end held in contact with the ground. The end in contact with

Changes to legislation: There are currently no known outstanding effects for the Commission Decision of 20 March 2006 on the detailed technical requirements for carrying out the tests specified in Directive 2005/66/EC of the European Parliament and of the Council relating to the use of frontal protection systems on motor vehicles (notified under document number C(2006) 776) (Text with EEA relevance) (2006/368/EC). (See end of Document for details)

the ground should be vertically below the lowest point of contact of the tape with the frontal protection system or vehicle (see Figure 3). The vehicle is positioned in the normal ride attitude.

- 1.10. 'Essential outer front end dimensions' means solid points in space of the test frame, representing all points of the actual intended vehicle type where the frontal protection system would be liable to impact on the vehicle during testing.
- 1.11. The 'centre of the knee' of the legform impactor means the point about which the knee effectively bends.
- 1.12. The 'femur' of the legform impactor is defined as all components or parts of components (including flesh, skin covering, damper, instrumentation and brackets, pulleys, etc. attached to the impactor for the purpose of launching it) above the level of the centre of the knee.
- 1.13. The 'tibia' of the legform impactor is defined as all components or parts of components (including flesh, skin covering, instrumentation and brackets, pulleys, etc. attached to the impactor for the purpose of launching it) below the level of the centre of the knee. Note that the tibia as defined includes allowances for the mass etc. of the foot.

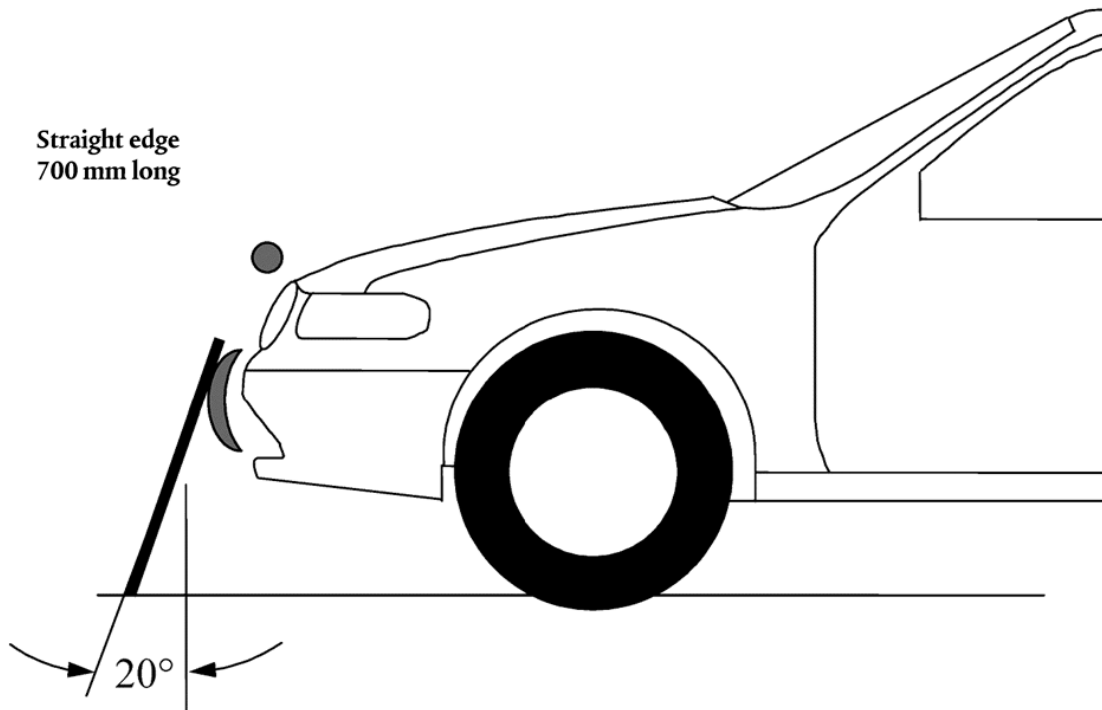

Changes to legislation: There are currently no known outstanding effects for the Commission Decision of 20 March 2006 on the detailed technical requirements for carrying out the tests specified in Directive 2005/66/EC of the European Parliament and of the Council relating to the use of frontal protection systems on motor vehicles (notified under document number C(2006) 776) (Text with EEA relevance) (2006/368/EC). (See end of Document for details)

**Straight edge
700 mm long**

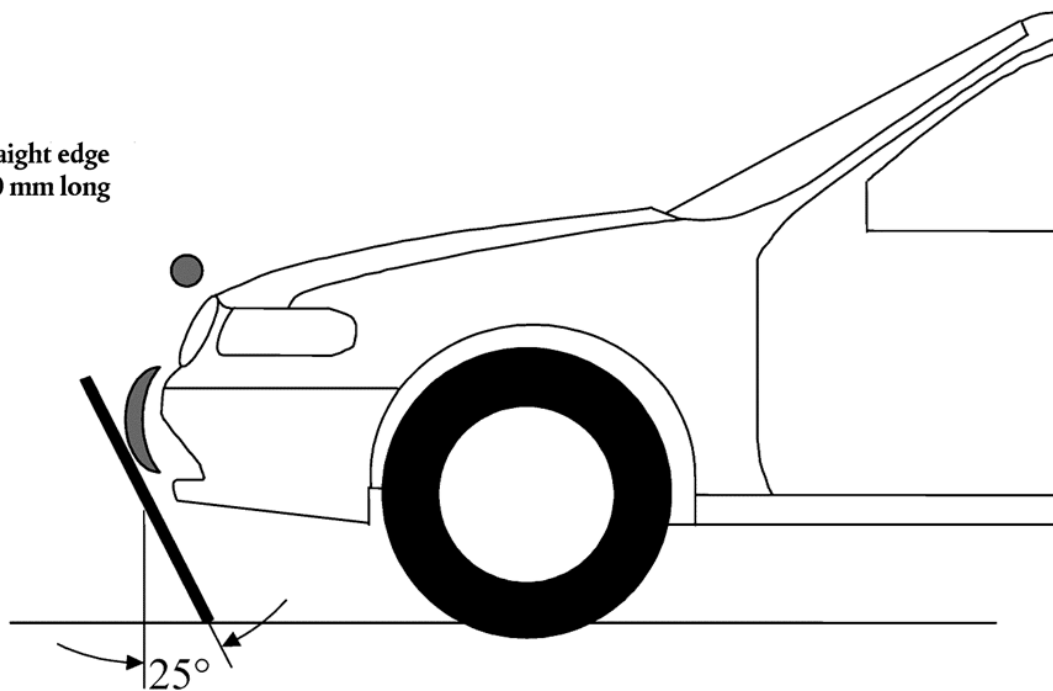

**Frontal protection system
wrap around distance**

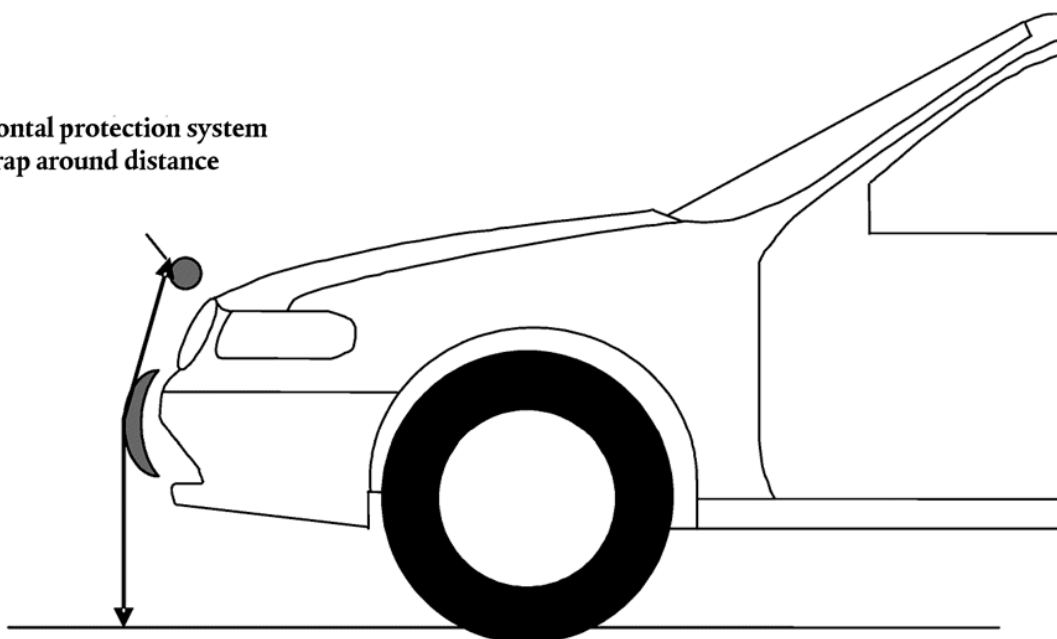

Changes to legislation: There are currently no known outstanding effects for the Commission Decision of 20 March 2006 on the detailed technical requirements for carrying out the tests specified in Directive 2005/66/EC of the European Parliament and of the Council relating to the use of frontal protection systems on motor vehicles (notified under document number C(2006) 776) (Text with EEA relevance) (2006/368/EC). (See end of Document for details)

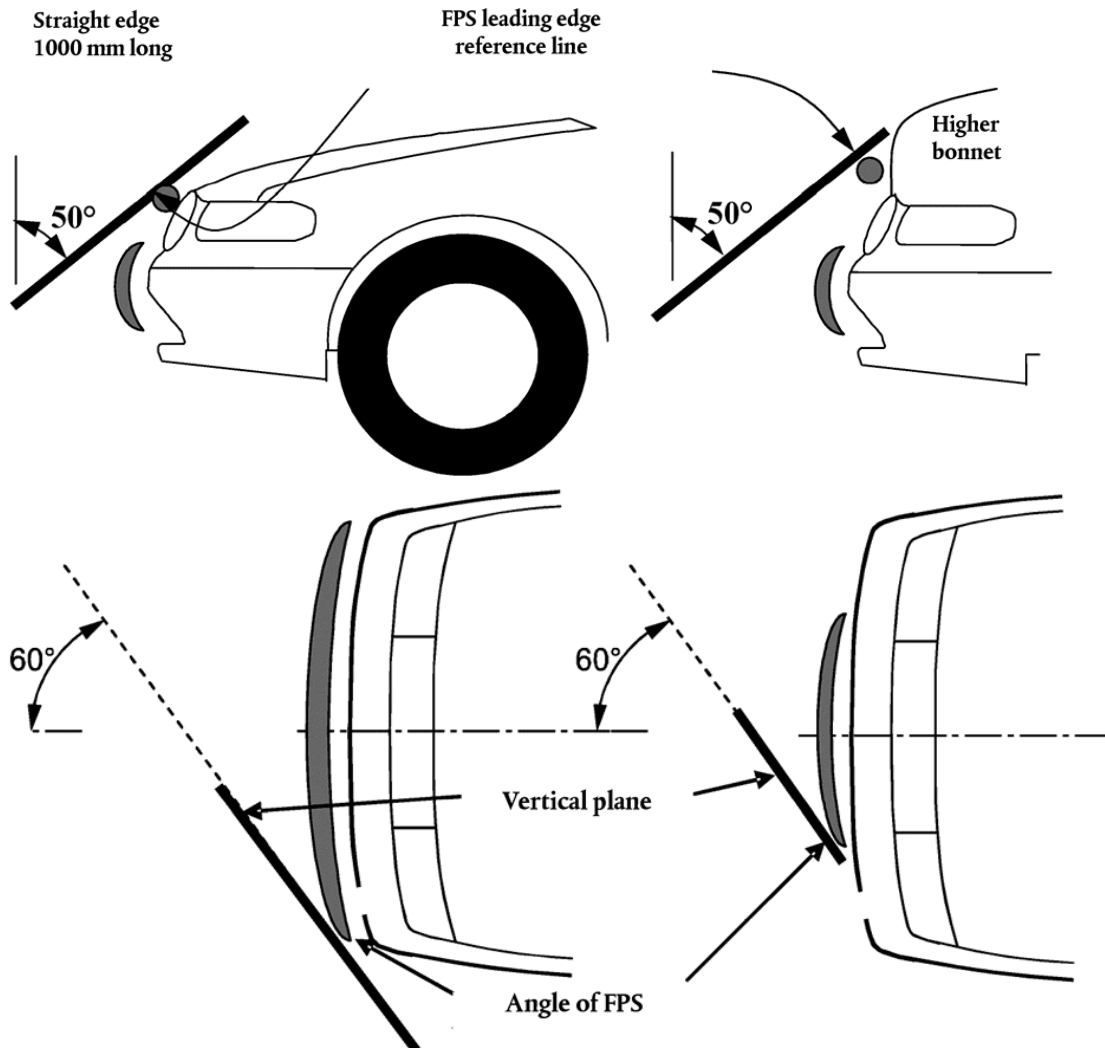

PART II U.K.

CHAPTER I U.K.

Test set-up

1. Testing the frontal protection system as original equipment fitted to a vehicle.
 - 1.1. The frontal protection system mounted on the vehicle must comply with the conditions laid down in Section 2 of Annex I to Directive 2005/66/EC.
 - 1.2. The vehicle must be in its normal ride attitude and either securely mounted on raised supports or at rest on a flat surface with the handbrake on. The vehicle must be fitted with the frontal protection system to be tested. The fitting instructions from the manufacturer of the frontal protection system must be followed and these should include tightening torques for all fixings.

Changes to legislation: There are currently no known outstanding effects for the Commission Decision of 20 March 2006 on the detailed technical requirements for carrying out the tests specified in Directive 2005/66/EC of the European Parliament and of the Council relating to the use of frontal protection systems on motor vehicles (notified under document number C(2006) 776) (Text with EEA relevance) (2006/368/EC). (See end of Document for details)

- 1.3. All devices designed to protect pedestrians and other vulnerable road users must be correctly activated before and/or be active during the appropriate test. The applicant must demonstrate that the devices will function as intended if the vehicle strikes a pedestrian or other vulnerable road user.
- 1.4. Any vehicle component that could change shape or position, such as ‘pop-up’ headlamps, other than devices to protect pedestrians and other vulnerable road users, must be set to a shape or position that the test authorities consider to be most appropriate for these tests.
2. Testing of frontal protection system as separate technical unit.
 - 2.1. Where only a frontal protection system is supplied for tests, it shall be possible to comply with the conditions laid down in Section 2 of Annex I to Directive 2005/66/EC when fitted to the vehicle type to which the separate technical unit type-approval relates.
 - 2.2. The test may be carried out either with the frontal protection system mounted on a vehicle of the type for which it is intended or on a test frame closely representing the essential outer front end dimensions of the intended vehicle type. If, when using a test frame, the frontal protection system makes contact with the frame during testing, the test must be repeated with the frontal protection system mounted on the actual vehicle type for which it is intended. In the case of testing carried out when the frontal protection system is mounted on a vehicle the conditions of Section 1 shall apply.

CHAPTER II **U.K.**

Test provisions

1. To be approved, frontal protection systems must comply with the test provisions laid down in Section 3 of Annex I to Directive 2005/66/EC.
2. Propulsion systems **U.K.**
 - 2.1. The lower legform impactor for the frontal protection system tests shall be in ‘free flight’ at the moment of impact. The impactor shall be released to free flight at such a distance that the test results are not influenced by any contact of the impactor with the propulsion system during rebound of the impactor.
 - 2.2. The upper legform impactor for tests to the frontal protection system and the frontal protection system upper leading edge shall be mounted to the propulsion system, by a torque limiting joint, to prevent large off-centre loads damaging the guidance system. The guidance system shall be fitted with low-friction guides, insensitive to off-axis loading, that allow the impactor to move only in the specified direction of impact, when in contact with the frontal protection system. The guides shall prevent motion in other directions including rotation about any other axis.
 - 2.3. The child/small adult headform impactor for the frontal protection system tests shall be in ‘free flight’ at the moment of impact. The impactor shall be released to free flight at such a distance from the frontal protection system that the test results are not influenced by any contact of the impactor with the propulsion system during rebound of the impactor.

Changes to legislation: There are currently no known outstanding effects for the Commission Decision of 20 March 2006 on the detailed technical requirements for carrying out the tests specified in Directive 2005/66/EC of the European Parliament and of the Council relating to the use of frontal protection systems on motor vehicles (notified under document number C(2006) 776) (Text with EEA relevance) (2006/368/EC). (See end of Document for details)

- 2.4. In all cases the impactors may be propelled by an air, spring or hydraulic gun, or by other means that can be shown to give the same result.

CHAPTER III U.K.

Lower legform to frontal protection system

1. Test purpose U.K.
 - 1.1. To test compliance with the requirements laid down in paragraph 3.1.1 of Annex I to Directive 2005/66/EC.
2. Test points U.K.
 - 2.1. A minimum of three lower legform to frontal protection system tests must be carried out on test points between the upper and lower frontal protection system reference lines (see Figures 1 and 2). The test points must be at positions judged by the test authority to be the most likely to cause injury. Tests must be carried out to different types of structure where they vary throughout the area to be assessed. The points tested by the test authorities shall be indicated in the test report.
3. Test apparatus U.K.
 - 3.1. The lower legform impactor must consist of two foam covered rigid segments, representing femur (upper leg) and tibia (lower leg), joined by a deformable, simulated knee joint. The overall length of the impactor must be 926 ± 5 mm and comply with the requirements laid down in Section 5 of this Chapter and with Figure 6. Brackets, pulleys, etc., attached to the impactor for the purpose of launching it, may extend the dimensions shown in Figure 6.
 - 3.2. Transducers must be fitted to measure knee-bending angle and knee-shearing displacement. One uni-axial accelerometer must be fitted to the non-impacted side of the tibia, close to the knee joint, with its sensitive axis in the impact direction.
 - 3.3. The instrumentation response value CFC, as defined in ISO 6487: 2000, must be 180 for all transducers. The CAC response values, as defined in ISO 6487: 2000, must be 50° for the knee-bending angle, 10 mm for the shearing displacement and 500 g for the acceleration.
 - 3.4. The impactor must meet the performance requirements specified in Section 2 of Appendix I, and must be fitted with deformable knee elements from the same batch as those used in the certification tests. The impactor must also be fitted with foam cut from one of up to four consecutive sheets of Confor™ foam flesh material, or equivalent, produced from the same batch of manufacture (cut from one block or bun of foam), provided that foam from one of these sheets was used in the dynamic certification test and the individual weights of these sheets are within ± 2 % of the weight of the sheet used in the certification test. The certified impactor may be used for a maximum of 20 impacts before re-certification. With each test new plastically deformable knee elements should be used. The impactor must also be re-certified if more than one year has elapsed since the previous certification or if any impactor transducer output, in any impact, has exceeded the specified CAC.
 - 3.5. The impactor must be mounted, propelled and released as specified in Chapter II.
4. Test procedure U.K.

Changes to legislation: There are currently no known outstanding effects for the Commission Decision of 20 March 2006 on the detailed technical requirements for carrying out the tests specified in Directive 2005/66/EC of the European Parliament and of the Council relating to the use of frontal protection systems on motor vehicles (notified under document number C(2006) 776) (Text with EEA relevance) (2006/368/EC). (See end of Document for details)

- 4.1. The stabilised temperature of the test apparatus and the vehicle or separate technical unit must be $20^{\circ} \pm 4^{\circ}\text{C}$.
- 4.2. Tests must be made to the frontal protection system at points selected under paragraph 2.1.
- 4.3. The direction of impact must be in the horizontal plane and parallel to the longitudinal vertical plane of the frontal protection system as mounted on the vehicle or mounting frame. The tolerance for the direction of the velocity vector in the horizontal plane and in the longitudinal plane must be $\pm 2^{\circ}$ at the time of first contact.
- 4.4. The axis of the impactor must be perpendicular to the horizontal plane with a tolerance of $\pm 2^{\circ}$ in the lateral and longitudinal plane. The horizontal, longitudinal and lateral planes are orthogonal to each other (see Figure 8).
- 4.5. The bottom of the impactor must be 25 mm above ground reference level at the time of first contact with the frontal protection system (see Figure 7), with a ± 5 mm tolerance. When setting the height of the propulsion system, an allowance must be made for the influence of gravity during the period of free flight of the impactor.
- 4.6. At the time of first contact the impactor must have the intended orientation about its vertical axis, for the correct operation of its knee joint, with a tolerance of $\pm 5^{\circ}$.
- 4.7. At the time of the first contact the centre line of the impactor must be within ± 10 mm tolerance to the selected impact position.
- 4.8. During contact between the impactor and the frontal protection system, the impactor must not contact the ground or any object which is not part of the frontal protection system or the vehicle.
- 4.9. The impact velocity of the impactor when striking the frontal protection system must be $11,1 \pm 0,2$ m/s. The effect of gravity must be taken into account when the impact velocity is obtained from measurements taken before the time of first contact.
5. Lower legform impactor **U.K.**
 - 5.1. The diameter of the femur and tibia must be 70 ± 1 mm and both must be covered by foam 'flesh' and skin. The foam flesh must be 25 mm thick Confor™ foam type CF-45, or equivalent. The skin must be made of neoprene foam, faced with 0,5 mm thick nylon cloth both sides, with an overall thickness of 6 mm.
 - 5.1.1. The length of the femur and tibia must be 432 mm and 494 mm from the centre of the knee respectively.
 - 5.2. The total mass of the femur and tibia must be $8,6 \pm 0,1$ kg and $4,8 \pm 0,1$ kg respectively, and the total mass of the impactor must be $13,4 \pm 0,2$ kg.
 - 5.3. The centre of gravity of the femur and tibia must be 217 ± 10 mm and 233 ± 10 mm from the centre of the knee respectively.
 - 5.4. The moment of inertia of the femur and tibia, about a horizontal axis through the respective centre of gravity and perpendicular to the direction of impact, must be $0,127 \pm 0,010$ kgm² and $0,120 \pm 0,010$ kgm² respectively.
 - 5.5. A uni-axial accelerometer must be mounted on the non-impacted side of the tibia, 66 ± 5 mm below the knee joint centre, with its sensitive axis in the direction of impact.

Changes to legislation: There are currently no known outstanding effects for the Commission Decision of 20 March 2006 on the detailed technical requirements for carrying out the tests specified in Directive 2005/66/EC of the European Parliament and of the Council relating to the use of frontal protection systems on motor vehicles (notified under document number C(2006) 776) (Text with EEA relevance) (2006/368/EC). (See end of Document for details)

- 5.6. The impactor must be instrumented to measure the bending angle and the shearing displacement between femur and tibia.
- 5.7. A damper must be fitted to the shear displacement system and may be mounted at any point on the rear face of the impactor or internally. The damper properties must be such that the impactor meets both the static and dynamic shear displacement requirements and prevents excessive vibrations of the shear displacement system.

Changes to legislation: There are currently no known outstanding effects for the Commission Decision of 20 March 2006 on the detailed technical requirements for carrying out the tests specified in Directive 2005/66/EC of the European Parliament and of the Council relating to the use of frontal protection systems on motor vehicles (notified under document number C(2006) 776) (Text with EEA relevance) (2006/368/EC). (See end of Document for details)

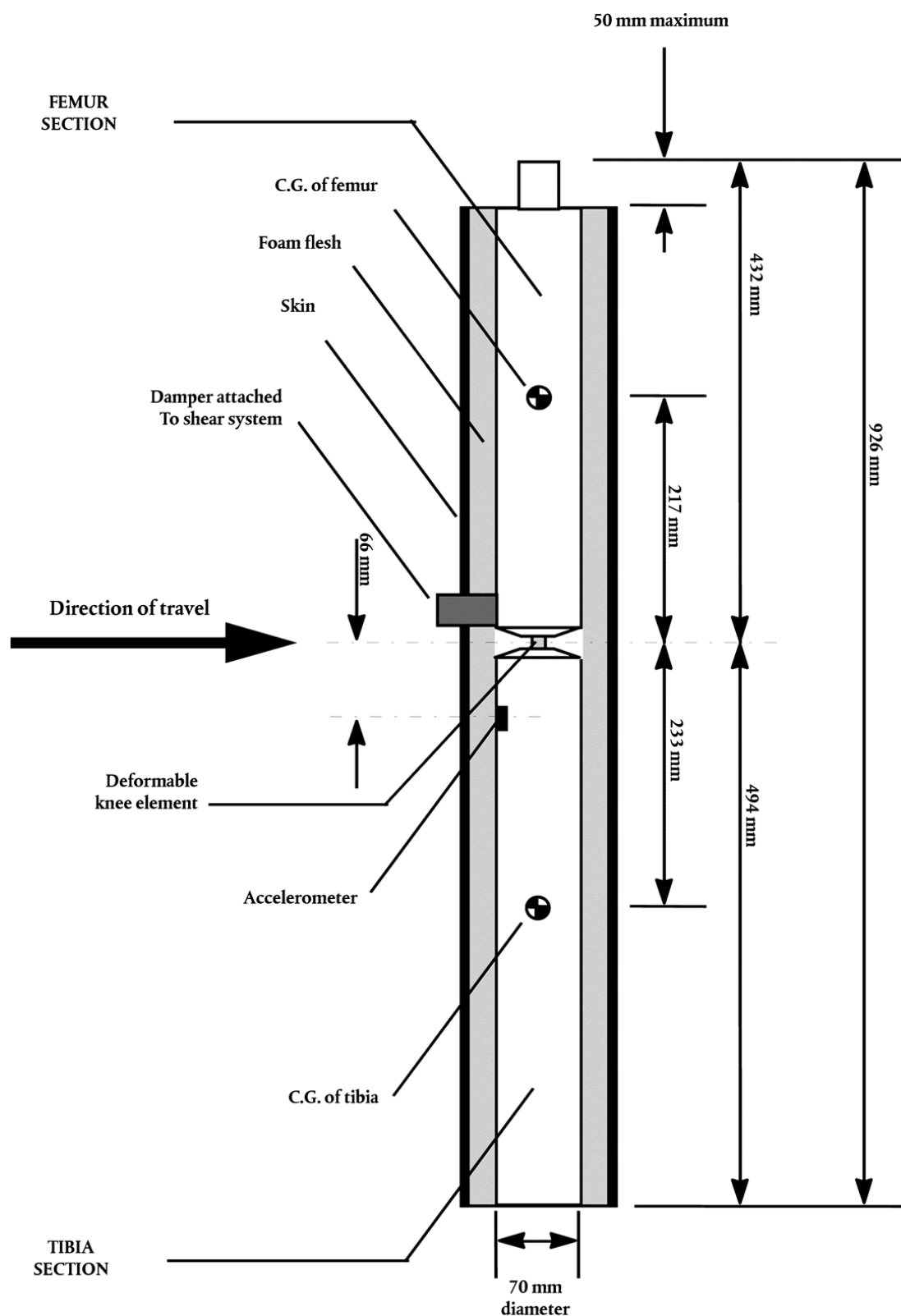

Changes to legislation: There are currently no known outstanding effects for the Commission Decision of 20 March 2006 on the detailed technical requirements for carrying out the tests specified in Directive 2005/66/EC of the European Parliament and of the Council relating to the use of frontal protection systems on motor vehicles (notified under document number C(2006) 776) (Text with EEA relevance) (2006/368/EC). (See end of Document for details)

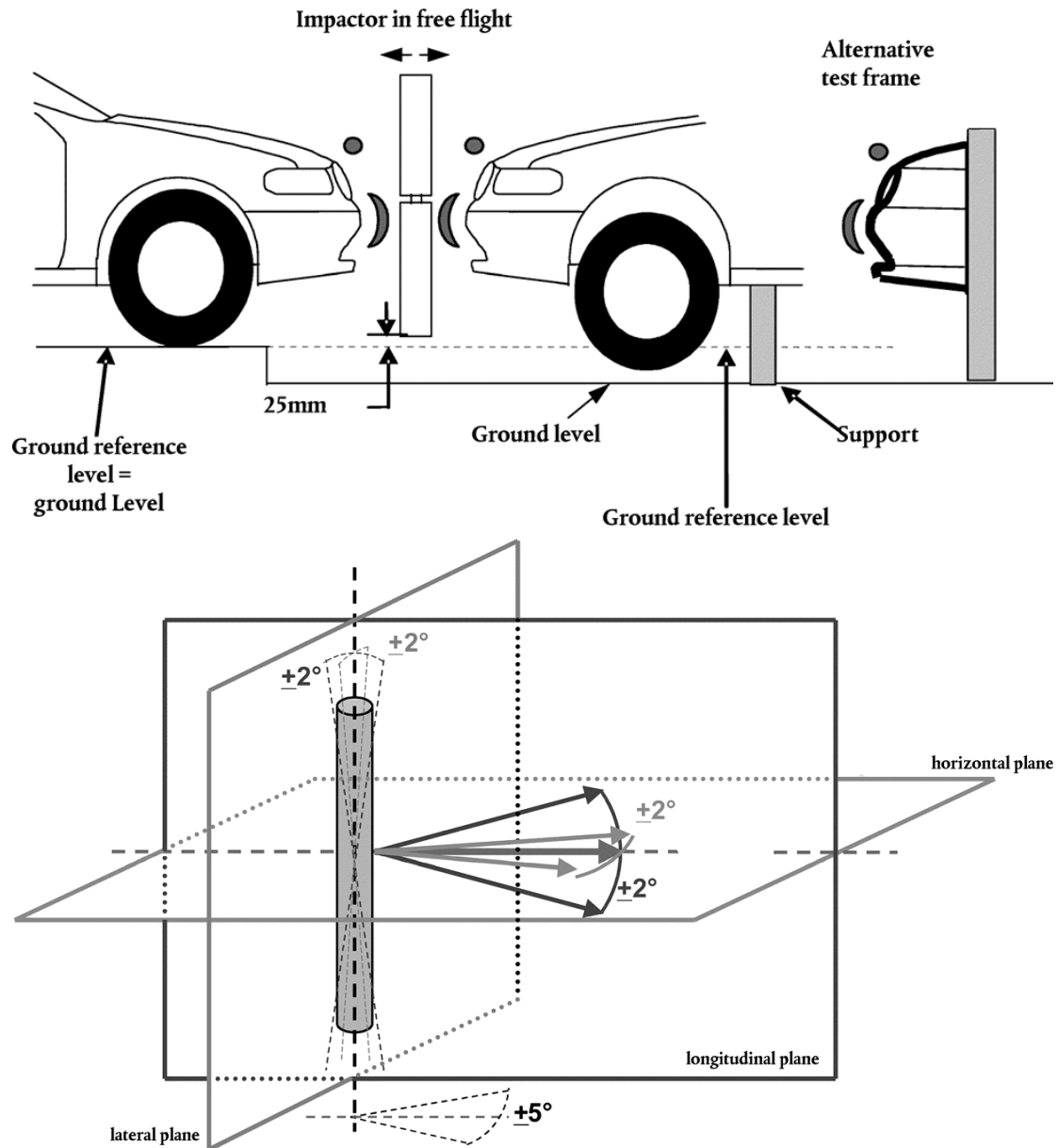

CHAPTER IV U.K.

Upper legform to frontal protection system

1. Test purpose U.K.
- 1.1. To test compliance with the requirements laid down in paragraph 3.1.2 of Annex I to Directive 2005/66/EC.
2. Test points U.K.
- 2.1. Upper legform to frontal protection system tests must be carried out to test points selected by the test authority in accordance with paragraph 2.1 of Chapter III. The points tested by the authorities must be indicated in the test report.

Changes to legislation: There are currently no known outstanding effects for the Commission Decision of 20 March 2006 on the detailed technical requirements for carrying out the tests specified in Directive 2005/66/EC of the European Parliament and of the Council relating to the use of frontal protection systems on motor vehicles (notified under document number C(2006) 776) (Text with EEA relevance) (2006/368/EC). (See end of Document for details)

3. Test apparatus **U.K.**
 - 3.1. The impactor must comply with the requirements laid down in Section 5 of this Chapter and with Figure 9.
 - 3.2. Two load transducers must be fitted to measure individually the forces applied at either end of the impactor, plus strain gauges measuring bending moments at the centre of the impactor and at positions 50 mm either side of the centre line (see Figure 9).
 - 3.3. The instrumentation response value CFC, as defined in ISO 6487:2000, must be 180 for all transducers. The CAC response values, as defined in ISO 6487:2000, must be 10 kN for the force transducers and 1000 Nm for the bending moment measurements.
 - 3.4. The impactor must meet the performance requirements specified in Section 3 of Appendix I, and must be fitted with foam cut from the sheet of material used for the dynamic certification test. The certified impactor may be used for a maximum of 20 impacts before re-certification (this limit does not apply to propulsion or guidance components). The impactor must also be re-certified if more than one year has elapsed since the previous certification or if any impactor transducer output, in any impact, has exceeded the specified CAC.
 - 3.5. The impactor must be mounted and propelled as specified in Chapter II.
4. Test procedure **U.K.**
 - 4.1. The stabilised temperature of the test apparatus and the vehicle or sub-system must be $20^{\circ} \pm 4^{\circ} \text{C}$.
 - 4.2. Tests must be made to the frontal protection system between the corners of the frontal protection system, to points selected under paragraph 2.1.
 - 4.3. The direction of impact must be parallel to the longitudinal axis of the frontal protection system as mounted on the vehicle or test frame, with the axis of the upper legform vertical at the time of the first contact. The tolerance to these directions is $\pm 2^{\circ}$. At the time of first contact the impactor centre line must be coincident with the selected test point with a ± 10 mm tolerance both laterally and vertically.
 - 4.4. The impact velocity of the impactor when striking the frontal protection system must be $11,1 \pm 0,2$ m/s.
5. Upper legform impactor **U.K.**
 - 5.1. The total mass of the upper legform impactor including those propulsion and guidance components which are effectively part of the impactor during the impact must be $9,5 \text{ kg} \pm 0,1 \text{ kg}$.
 - 5.2. The total mass of the front member and other components in front of the load transducer assemblies, together with those parts of the load transducer assemblies in front of the active elements, but excluding the foam and skin, must be $1,95 \pm 0,05 \text{ kg}$.
 - 5.3. The foam must be two sheets of 25 mm thick Confor™ foam type CF-45, or equivalent. The skin must be a 1,5 mm thick fibre reinforced rubber sheet. The foam and rubber skin together must weigh $0,6 \pm 0,1 \text{ kg}$ (this excludes any reinforcement, mountings, etc. which are used to attach the rear edges of the rubber skin to the rear member). The foam and rubber skin must be folded back towards the rear, with the rubber skin attached via spacers to the rear member so that the sides of the rubber skin are held parallel. The foam must of such a size and shape that an adequate gap

Changes to legislation: There are currently no known outstanding effects for the Commission Decision of 20 March 2006 on the detailed technical requirements for carrying out the tests specified in Directive 2005/66/EC of the European Parliament and of the Council relating to the use of frontal protection systems on motor vehicles (notified under document number C(2006) 776) (Text with EEA relevance) (2006/368/EC). (See end of Document for details)

is maintained between the foam and components behind the front member, to avoid significant load paths between the foam and these components.

- 5.4. The front member must be strain gauged to measure bending moments in three positions, as shown in Figure 9, each using a separate channel. The strain gauges are located on the impactor on the back of the front member. The two outer strain gauges are located 50 ± 1 mm from the impactor's symmetrical axis. The middle strain gauge is located on the symmetrical axis with a ± 1 mm tolerance.
- 5.5. The torque limiting joint must be set so that the longitudinal axis of the front member is perpendicular to the axis of the guidance system, with a tolerance of $\pm 2^\circ$, with the joint friction torque set to a minimum of 650 Nm.
- 5.6. The centre of gravity of those parts of the impactor which are effectively forward of the torque limiting joint must lie on the longitudinal centre line of the impactor, with a tolerance of ± 10 mm.
- 5.7. The length between the load transducer centrelines must be 310 ± 1 mm and the front member diameter must be 50 ± 1 mm.

Changes to legislation: There are currently no known outstanding effects for the Commission Decision of 20 March 2006 on the detailed technical requirements for carrying out the tests specified in Directive 2005/66/EC of the European Parliament and of the Council relating to the use of frontal protection systems on motor vehicles (notified under document number C(2006) 776) (Text with EEA relevance) (2006/368/EC). (See end of Document for details)

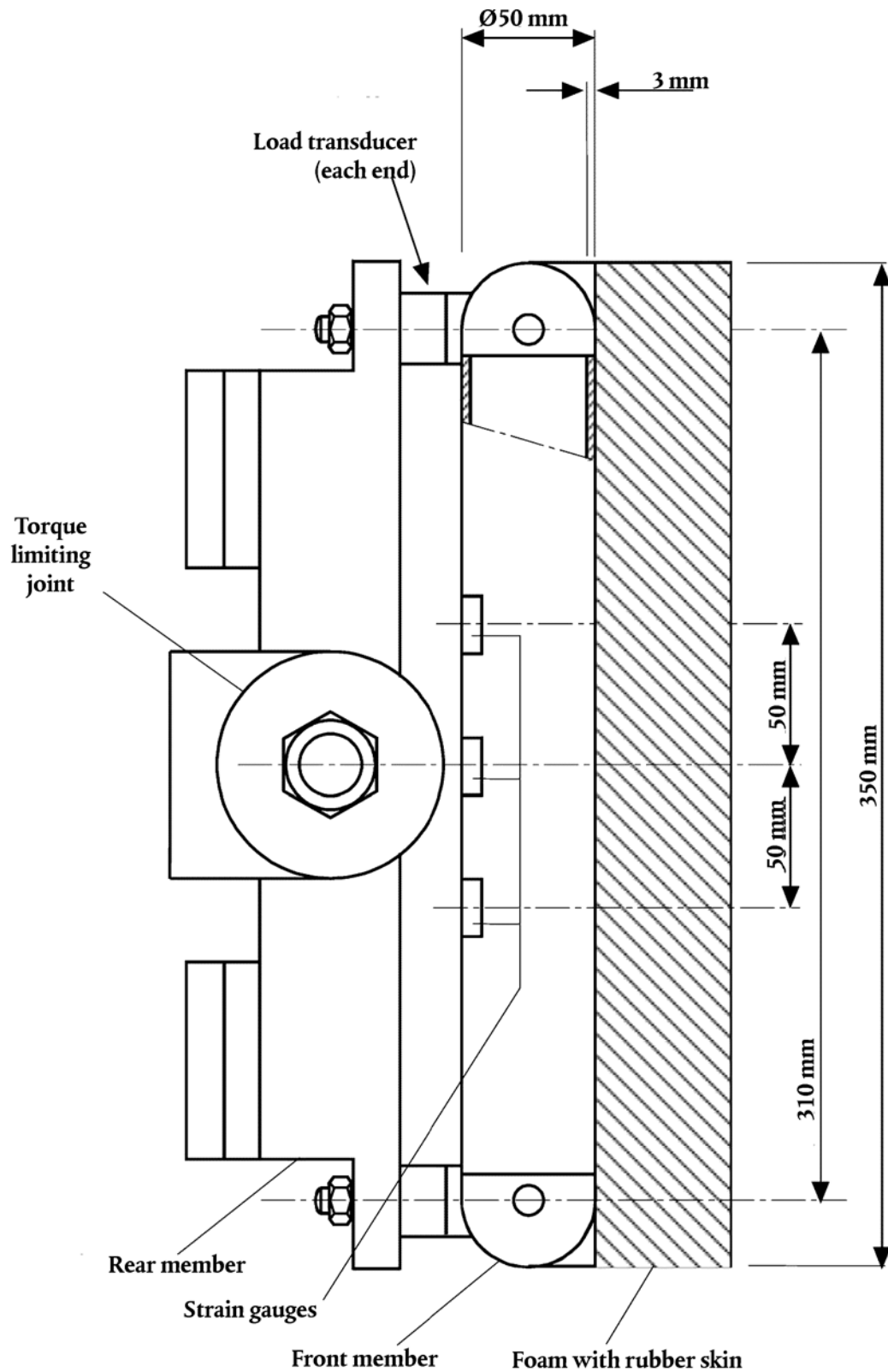

Changes to legislation: There are currently no known outstanding effects for the Commission Decision of 20 March 2006 on the detailed technical requirements for carrying out the tests specified in Directive 2005/66/EC of the European Parliament and of the Council relating to the use of frontal protection systems on motor vehicles (notified under document number C(2006) 776) (Text with EEA relevance) (2006/368/EC). (See end of Document for details)

CHAPTER V U.K.

Upper legform to frontal protection system leading edge

1. Test purpose U.K.
- 1.1. To test compliance with the requirements laid down in paragraph 3.1.3 of Annex I to Directive 2005/66/EC.
2. Test points U.K.
- 2.1. A minimum of three tests must be carried out to the frontal protection system leading edge reference line, at points judged by the test authority to be the most likely to cause injury. Tests shall be to different types of structure where they vary throughout the area to be assessed. The points tested by the test authorities must be indicated in the test report.
3. Test apparatus U.K.
- 3.1. The impactor must comply with the requirements laid down in Section 5 of Chapter IV and with Figure 9.
- 3.2. When impacting the upper leading edge reference line the impactor mass shall depend upon the general shape of the frontal protection system and must be determined in accordance with Section 4.
- 3.3. Two load transducers must be fitted to individually measure the forces applied at either end of the impactor, plus strain gauges to measure the bending moments at the centre of the impactor and at positions 50 mm either side of the centre line. (see Figure 9)
- 3.4. The instrumentation response value CFC, as defined in ISO 6487:2000, must be 180 for all transducers. The CAC response values, as defined in ISO 6487:2000, must be 10 kN for the force transducers and 1000 Nm for the bending moment measurements.
- 3.5. The impactor must meet the performance requirements specified in Section 3 of Appendix I, and shall be fitted with foam cut from the sheet of material used for the dynamic certification test. The certified impactor may be used for a maximum of 20 impacts before re-certification (this limit does not apply to propulsion or guidance components). The impactor must also be re-certified if more than one year has elapsed since the previous certification or if any impactor transducer output, in any impact, has exceeded the specified CAC.
- 3.6. The impactor must be mounted and propelled as specified in Chapter II.
4. Test procedure U.K.
- 4.1. The stabilised temperature of the test apparatus and the vehicle or sub-system must be $20^{\circ} \pm 4^{\circ}\text{C}$.
- 4.2. The tests must be made to the frontal protection system between the corners of the frontal protection system upper leading edge, to points selected under paragraph 2.1.
- 4.3. The impactor must be aligned in such a way that the centre line of the propulsion system and the longitudinal axis of the impacting impactor are parallel to the longitudinal axis of the frontal protection system as mounted on the vehicle or test frame. The tolerances to these directions are $\pm 2^{\circ}$. At the time of first contact the impactor centre line must be coincident with the selected impact position with a ± 10 mm tolerance (see Figure 10), and laterally with a tolerance of ± 10 mm.

Changes to legislation: There are currently no known outstanding effects for the Commission Decision of 20 March 2006 on the detailed technical requirements for carrying out the tests specified in Directive 2005/66/EC of the European Parliament and of the Council relating to the use of frontal protection systems on motor vehicles (notified under document number C(2006) 776) (Text with EEA relevance) (2006/368/EC). (See end of Document for details)

- 4.4. The required impact velocity, the angle of impact and the impactor mass must be determined in accordance with paragraphs 4.5 and 4.6. The tolerance on the impact velocity is $\pm 2\%$ and the tolerance on the impact direction is $\pm 2^\circ$. The effect of gravity must be taken before the time of first contact. The impactor mass should be measured to an accuracy of better than $\pm 1\%$, and if the measured value differs from the required value then the required velocity should be adjusted to compensate, in accordance with paragraph 4.7.1.
- 4.5. The required impact velocity and the angle of impact are determined from Figures 11 and 12 with reference to the vertical height of the intended impact position on the frontal protection system leading edge reference line and the frontal protection system lead.
- 4.6. The required impact energy must be derived from Figure 13 with reference to the vertical height, from ground reference level, of the intended impact position on the frontal protection system leading edge and the frontal protection system lead.
- 4.7. The total mass of the impactor includes those propulsion and guidance components which are effectively part of the impactor during the impact, including the extra weights.
- 4.7.1. The required value of the impactor mass must be calculated in the following way:

M	$= 2E/V^2$
Where	M = Mass (kg) E = Required Impact Energy (J) V = Required Velocity (m/s)

- 4.7.2. The impactor mass may be adjusted from the calculated value by up to $\pm 10\%$, provided the required impact velocity is also changed using the above formula to maintain the required impactor kinetic energy.
- 4.7.3. The required extra weights must be fitted accordingly in order to give the calculated value of impactor mass, calculated in accordance with paragraph 4.7.1, to the rear of the rear member as shown in Figure 9, or to components of the guidance system which are effectively part of the impactor during the impact.

Changes to legislation: There are currently no known outstanding effects for the Commission Decision of 20 March 2006 on the detailed technical requirements for carrying out the tests specified in Directive 2005/66/EC of the European Parliament and of the Council relating to the use of frontal protection systems on motor vehicles (notified under document number C(2006) 776) (Text with EEA relevance) (2006/368/EC). (See end of Document for details)

Direction of impact

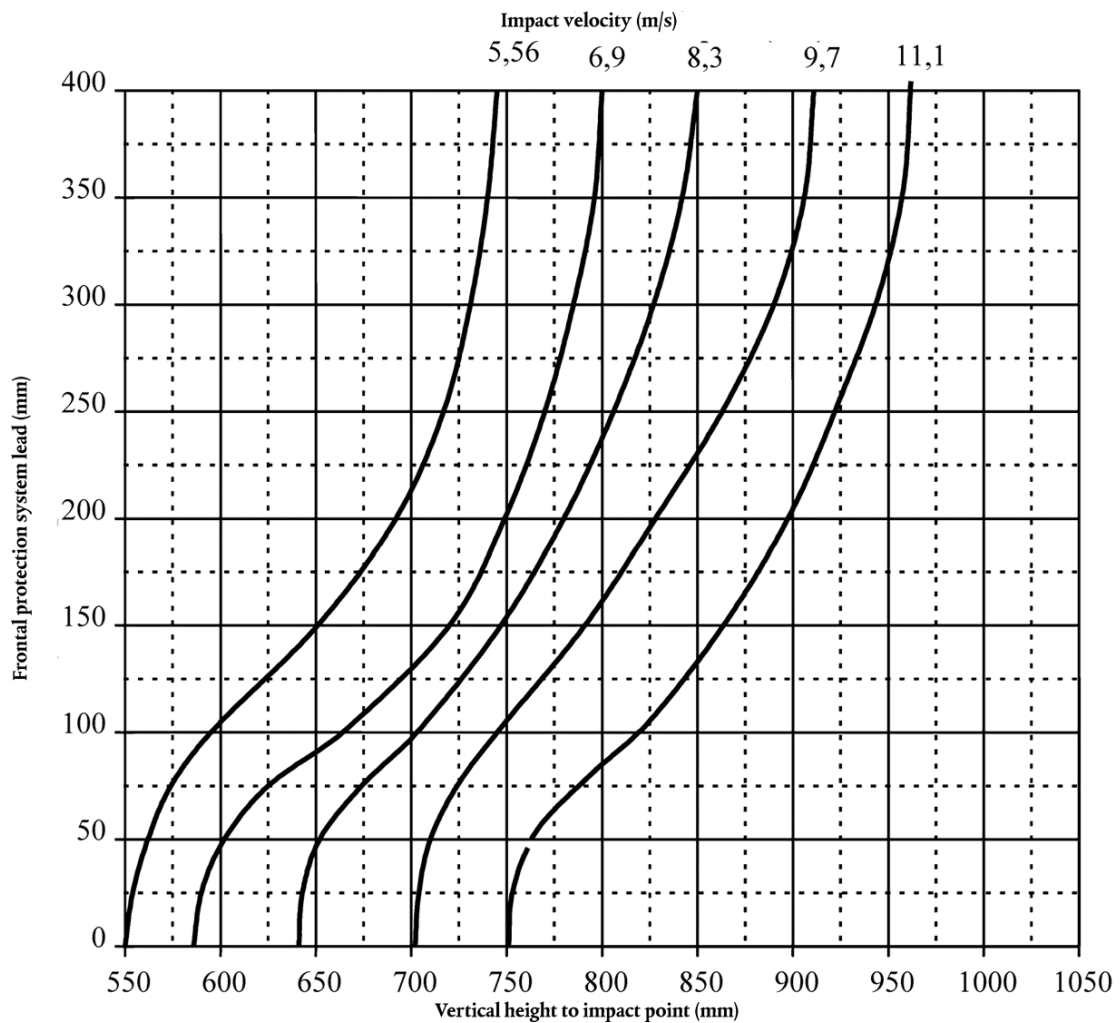
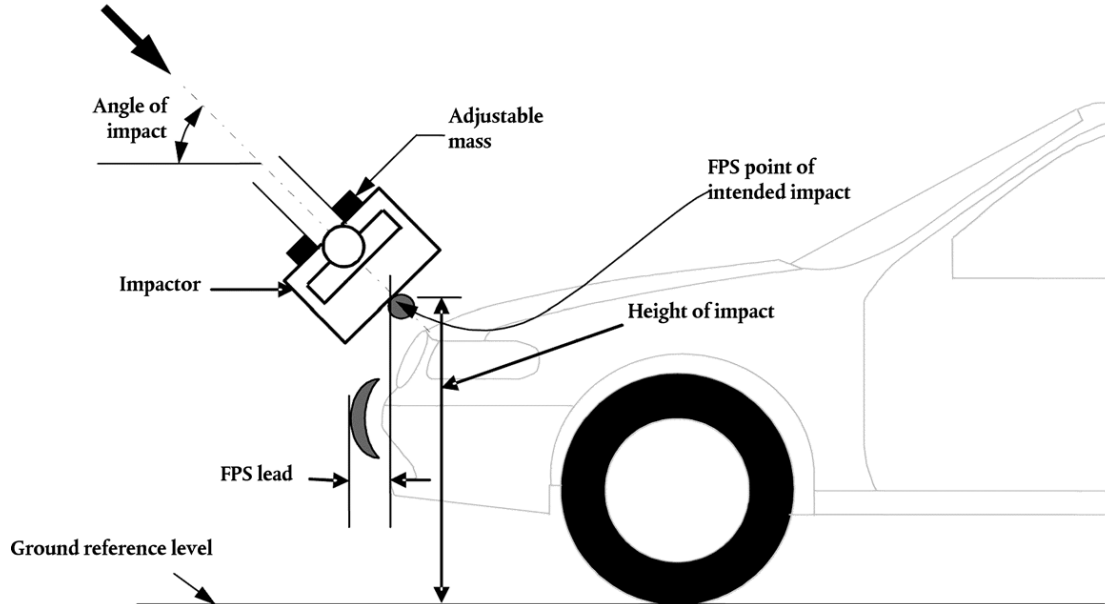

Changes to legislation: There are currently no known outstanding effects for the Commission Decision of 20 March 2006 on the detailed technical requirements for carrying out the tests specified in Directive 2005/66/EC of the European Parliament and of the Council relating to the use of frontal protection systems on motor vehicles (notified under document number C(2006) 776) (Text with EEA relevance) (2006/368/EC). (See end of Document for details)

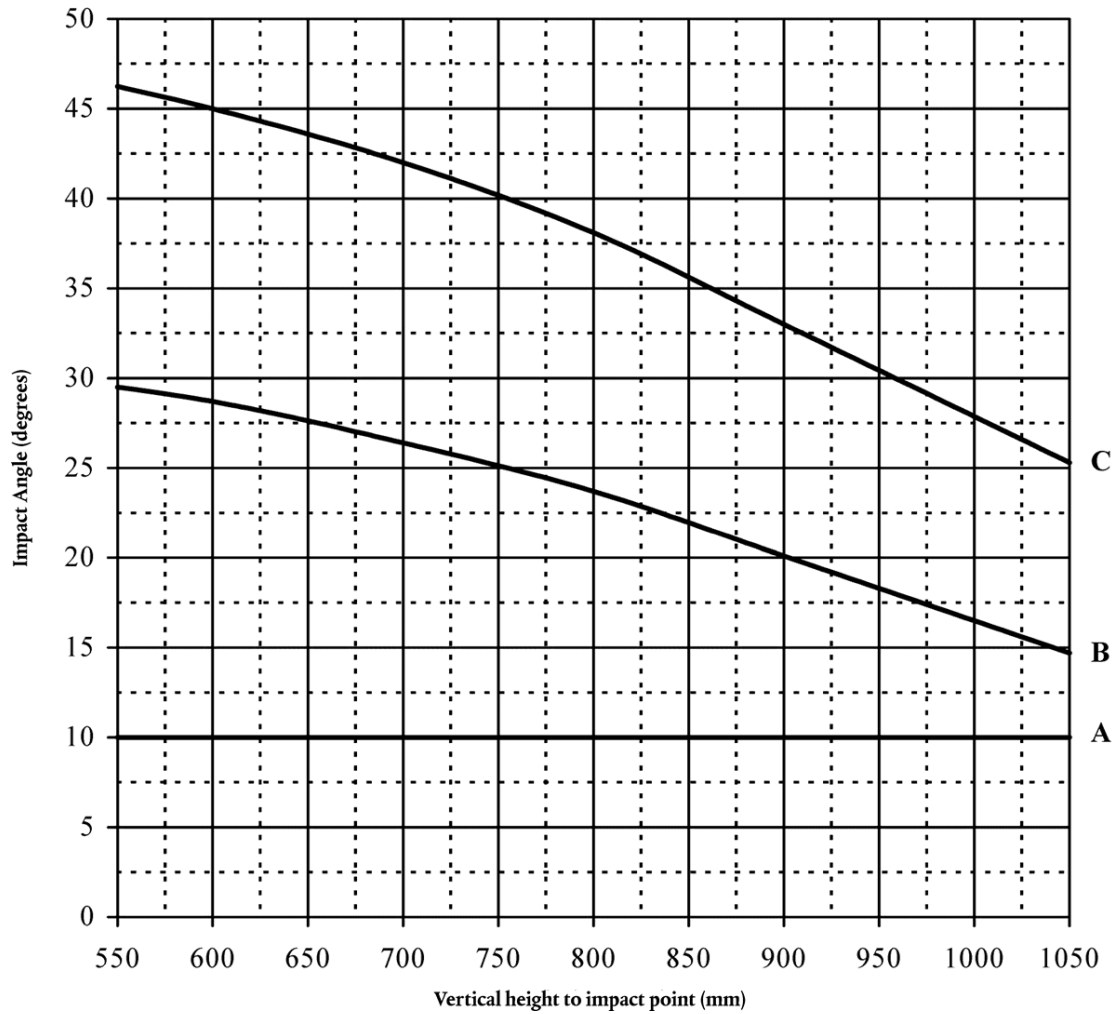

Changes to legislation: There are currently no known outstanding effects for the Commission Decision of 20 March 2006 on the detailed technical requirements for carrying out the tests specified in Directive 2005/66/EC of the European Parliament and of the Council relating to the use of frontal protection systems on motor vehicles (notified under document number C(2006) 776) (Text with EEA relevance) (2006/368/EC). (See end of Document for details)

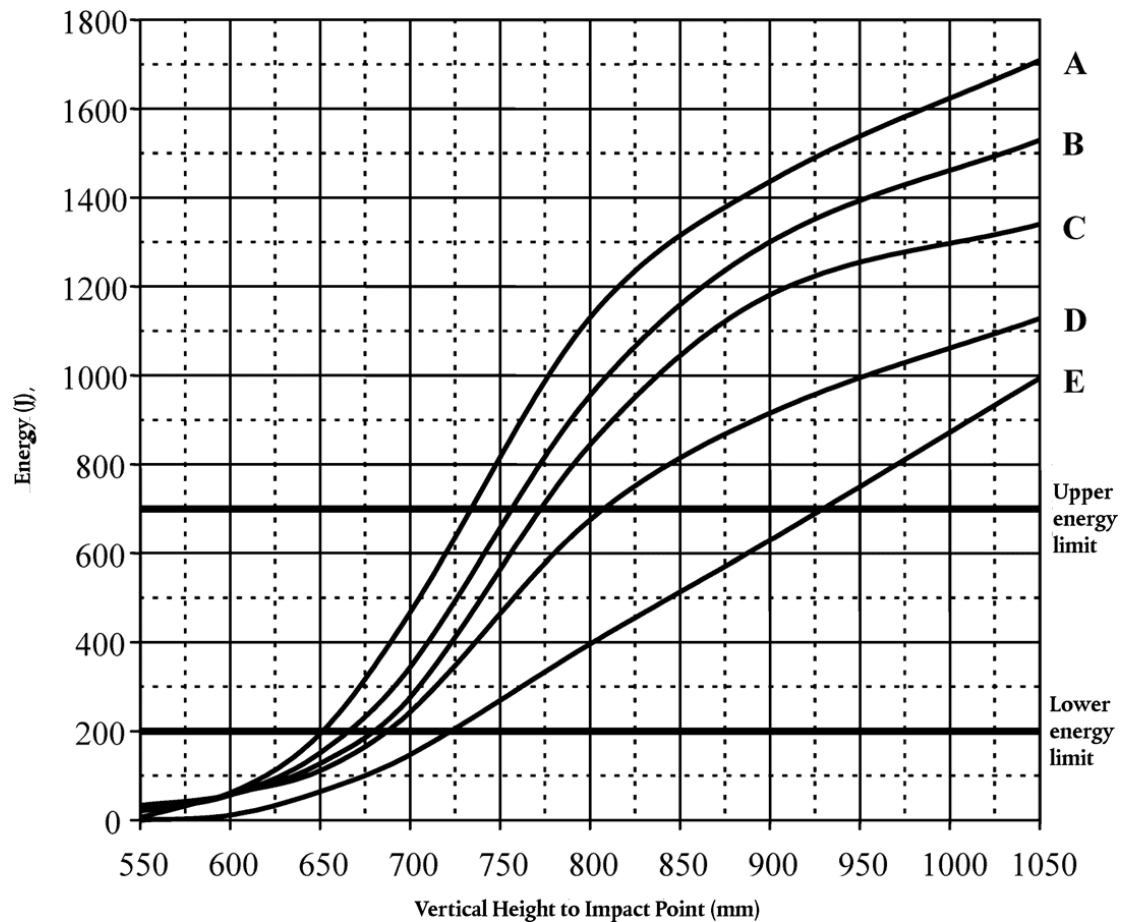

CHAPTER VI U.K.

Child/small adult headform to frontal protection system

1. Test purpose U.K.
 - 1.1. To test compliance with the requirements laid down in paragraph 3.1.4 of Annex I to Directive 2005/66/EC.
2. Test points U.K.
 - 2.1. Test points for the child/small adult headform impactor must be chosen on parts of the frontal protection system where the frontal protection system wrap around distance exceeds 900 mm with the vehicle in its normal ride attitude or with the frontal protection system mounted on a test frame representing the vehicle to which it is to be fitted as if in its' normal ride attitude.
 - 2.2. Three headform impact tests must be carried out at positions which are judged by the test laboratories to be the most likely to cause injury. Tests must be to different types of structure, where these vary throughout the area to be assessed. Points tested by the test authorities must be indicated in the test report.
3. Test apparatus U.K.

Changes to legislation: There are currently no known outstanding effects for the Commission Decision of 20 March 2006 on the detailed technical requirements for carrying out the tests specified in Directive 2005/66/EC of the European Parliament and of the Council relating to the use of frontal protection systems on motor vehicles (notified under document number C(2006) 776) (Text with EEA relevance) (2006/368/EC). (See end of Document for details)

- 3.1. The impactor must be as described in Section 5 and as shown in Figure 15.
- 3.2. The instrumentation response value CFC, as defined in ISO 6487:2000, must be 1 000. The CAC response value, as defined in ISO 6487:2000, must be 500 g for the acceleration.
- 3.3. The impactor must meet the performance requirements specified in Section 4 of Appendix I. The certified impactor may be used for a maximum of 20 impacts before re-certification. The impactor must be re-certified if more than one year has elapsed since the previous certification or if any transducer output, in any impact, has exceeded the specified CAC.
- 3.4. The impactor must be mounted, propelled and released as specified in Section 2 of Chapter II.
4. Test procedure **U.K.**
 - 4.1. The stabilised temperature of the test apparatus and the vehicle or separate technical unit must be $20^{\circ} \pm 4^{\circ}\text{C}$.
 - 4.2. Tests must be made to the frontal protection system at positions selected under Section 2.
 - 4.3. A child/small adult headform impactor, as described in Section 5, must be used for tests to the frontal protection system at positions of first contact as selected under Section 2.
 - 4.4. The direction of impact must be downward and rearward and in a vertical plane parallel to the longitudinal axis of the frontal protection system as mounted on the vehicle or the test frame. The tolerance for this direction is $\pm 2^{\circ}$. The angle of impact for tests with the impactor must be $50^{\circ} \pm 2^{\circ}$ to the ground reference level. The effect of gravity must be taken into account when the impact angle is obtained from measurements taken before the time of first contact.
 - 4.5. At the time of first contact, the point of first contact of the impactor must be within a ± 10 mm tolerance to the selected impact point.
 - 4.6. The impact velocity of the impactor when striking the impact position must be $9,7 \pm 0,2$ m/s. The effect of gravity must be taken into account when the impact velocity is obtained from measurements taken before the time of first contact.
5. Headform impactor **U.K.**
 - 5.1. The child/small adult headform impactor is a sphere made of aluminium and of homogenous construction. It shall have a diameter of 165 ± 1 mm and a mass of $3,5 \pm 0,07$ kg
 - 5.2. The sphere must be covered with a $14 \pm 0,5$ mm thick synthetic skin, which shall cover at least half of the sphere.
 - 5.3. The centre of gravity of the impactor, including instrumentation, must be located in the centre of the sphere with a tolerance of ± 5 mm. The moment of inertia about an axis through the centre of gravity and perpendicular to the direction of impact must be $0,010 \pm 0,0020$ kg/m².

Changes to legislation: There are currently no known outstanding effects for the Commission Decision of 20 March 2006 on the detailed technical requirements for carrying out the tests specified in Directive 2005/66/EC of the European Parliament and of the Council relating to the use of frontal protection systems on motor vehicles (notified under document number C(2006) 776) (Text with EEA relevance) (2006/368/EC). (See end of Document for details)

- 5.4. A recess in the sphere must allow for mounting one tri-axial or three uni-axial accelerometers. The accelerometers must be positioned in accordance with paragraphs 5.4.1 and 5.4.2.
- 5.4.1. One of the accelerometers must have its sensitive axis perpendicular to the mounting face A (figure 15) and its seismic mass must be positioned within a cylindrical tolerance field of 1 mm radius and 20 mm length. The centre line of the tolerance field must run perpendicular to the mounting face and its mid point shall coincide with the centre of the sphere of the impactor.
- 5.4.2. The remaining accelerometers must have their sensitive axes perpendicular to each other and parallel to the mounting face A and their seismic mass must be positioned within a spherical tolerance field of 10 mm radius. The centre of the tolerance field must coincide with the centre of the sphere of the impactor.

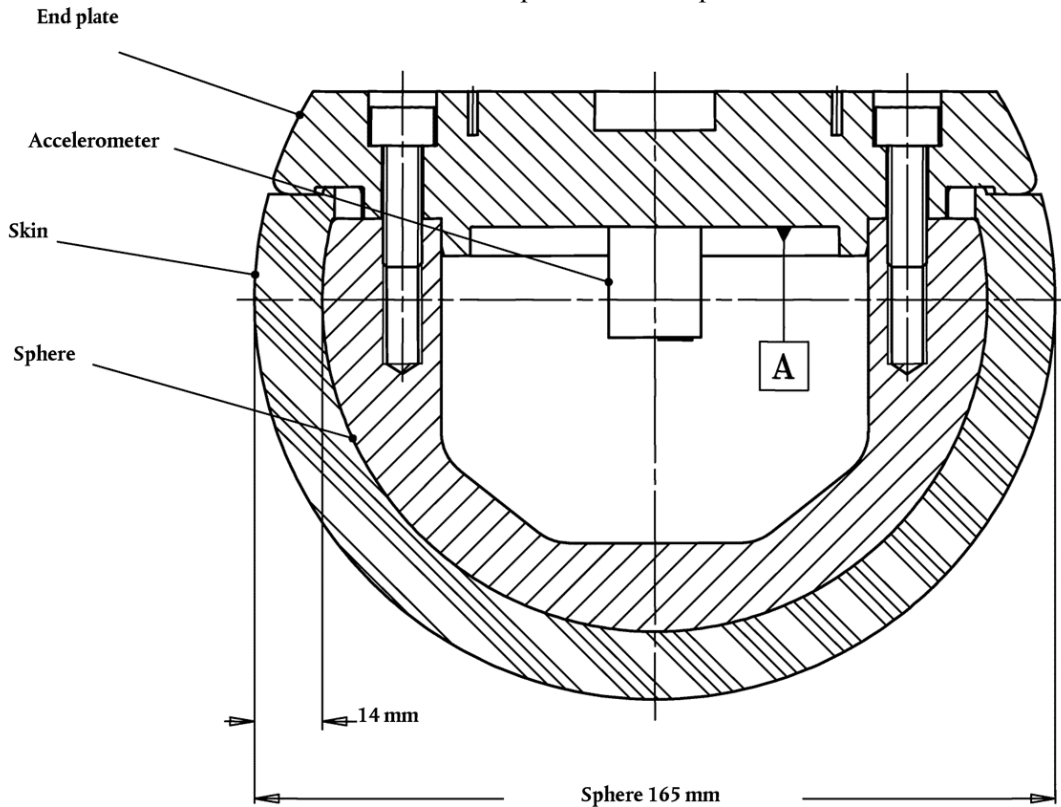

Changes to legislation: There are currently no known outstanding effects for the Commission Decision of 20 March 2006 on the detailed technical requirements for carrying out the tests specified in Directive 2005/66/EC of the European Parliament and of the Council relating to the use of frontal protection systems on motor vehicles (notified under document number C(2006) 776) (Text with EEA relevance) (2006/368/EC). (See end of Document for details)

Appendix 1 U.K.

Impactor certification

1. CERTIFICATION REQUIREMENTS U.K.
 - 1.1. The impactors used in the tests specified in Part II must comply with appropriate performance requirements.
 2. LOWER LEGFORM IMPACTOR U.K.
 - 2.1. Static tests U.K.
 - 2.1.1. The lower legform impactor must meet the requirements specified in paragraph 2.1.5 when tested in accordance with paragraph 2.1.7 and the requirements specified in paragraph 2.1.6 when tested in accordance with paragraph 2.1.8.
 - 2.1.2. For both tests the impactor must have the intended orientation about its longitudinal axis, for the correct operation of its knee joint, with a tolerance of $\pm 2^\circ$.
 - 2.1.3. The stabilised temperature of the impactor during certification must be $20^\circ \pm 2^\circ \text{ C}$.
 - 2.1.4. The CAC response values, as defined in ISO 6487:2000, must be 50° for the knee bending angle and 500 N for the applied force when the impactor is loaded in bending in accordance with paragraph 2.1.7, and 10 mm for the shearing displacement and 10 kN for the applied force when the impactor is loaded in shearing in accordance with paragraph 2.1.8. For both tests low-pass filtering at an appropriate frequency is permitted, to remove higher frequency noise without significantly affecting the measurement of the response of the impactor.
 - 2.1.5. When the impactor is loaded in bending in accordance with paragraph 2.1.7, the applied force/bending angle response must be within the limits shown in Figure 16. The energy taken to generate 15° of bending must be $100 \pm 7 \text{ J}$.
 - 2.1.6. When the impactor is loaded in shearing in accordance with paragraph 2.1.8, the applied force/shearing displacement response must be within the limits shown in Figure 17.
 - 2.1.7. The impactor, without foam covering and skin, shall be mounted with the tibia firmly clamped to a fixed horizontal surface and a metal tube connected firmly to the femur, as shown in Figure 18. To avoid friction errors, no support may be provided to the femur section or the metal tube. The bending moment applied at the centre of the knee joint, due to the weight of the metal tube and other components (excluding the legform itself), must not exceed 25 Nm.
 - 2.1.7.1. A horizontal normal force must be applied to the metal tube at a distance of $2,0 \pm 0,01 \text{ m}$ from the centre of the knee joint and the resulting angle of knee deflection must be recorded. The load must be increased until the angle of deflection of the knee exceeds 22° .
 - 2.1.7.2. The energy is calculated by integrating the force with respect to the bending angle in radians, and multiplying by the lever length of $2,0 \pm 0,01 \text{ m}$.
 - 2.1.8. The impactor, without foam covering and skin, must be mounted with the tibia firmly clamped to a fixed horizontal surface and a metal tube connected firmly to the femur and restrained at 2,0 m from the centre of the knee joint, as shown in Figure 19.

Changes to legislation: There are currently no known outstanding effects for the Commission Decision of 20 March 2006 on the detailed technical requirements for carrying out the tests specified in Directive 2005/66/EC of the European Parliament and of the Council relating to the use of frontal protection systems on motor vehicles (notified under document number C(2006) 776) (Text with EEA relevance) (2006/368/EC). (See end of Document for details)

- 2.1.8.1. A horizontal normal force must be applied to the femur at a distance of 50 mm from the centre of the knee joint and the resulting knee shearing displacement must be recorded. The load must be increased until the shearing displacement of the knee is in excess of 8,0 mm or the load exceeds of 6,0 kN.
- 2.2. Dynamic tests **U.K.**
 - 2.2.1. The impactor must meet the requirements specified in paragraph 2.2.3 when tested in accordance with paragraph 2.3.
 - 2.2.2. The stabilised temperature of the impactor during certification must be $20^{\circ} \pm 2^{\circ} \text{C}$.
 - 2.2.3. When the impactor is impacted by a linearly guided certification impactor, as specified in paragraph 2.3.2, the maximum upper tibia acceleration must be not less than 120 g and not more than 250 g. The maximum bending angle must be not less than $6,2^{\circ}$ and not more than $8,2^{\circ}$. The maximum shearing displacement must be not less than 3,5 mm and not more than 6,0 mm.
 - 2.2.4. For all these values the readings used must be from the initial impact with the certification impactor and not from the arresting phase. Any system used to arrest the impactor or certification impactor must be so arranged that the arresting phase does not overlap in time with the initial impact. The arresting system must not cause the transducer outputs to exceed the specified CAC.
 - 2.2.5. The instrumentation response value CFC, as defined in ISO 6487:2000, must be 180 for all transducers. The CAC response values, as defined in ISO 6487:2000, must be 50° for the knee bending angle, 10 mm for the shearing displacement and 500 g for the acceleration. This does not require that the impactor itself be able to physically bend and shear to these angles and displacements.
- 2.3. Test procedure **U.K.**
 - 2.3.1. The impactor, including foam covering and skin, must be suspended horizontally by three wire ropes of $1,5 \pm 0,2$ mm diameter and of 2,0 m minimum length, as shown in Figure 20. It must be suspended with its longitudinal axis horizontal, with a tolerance of $\pm 0,5^{\circ}$, and perpendicular to the direction of the certification impactor motion, with a tolerance of $\pm 2^{\circ}$. The impactor must have the intended orientation about its longitudinal axis, for the correct operation of its knee joint, with a tolerance of $\pm 2^{\circ}$. The impactor must meet the requirements specified in paragraph 3.1 of Chapter III, Part II, with the attachment bracket(s) for the wire ropes fitted.
 - 2.3.2. The certification impactor must have a mass of $9,0 \pm 0,05$ kg, this mass includes those propulsion and guidance components which are effectively part of the certification impactor during impact. The dimensions of the face of the certification impactor must be as specified in Figure 21. The face of the certification impactor must be made of aluminium, with an outer surface finish of better than at least 2,0 micrometers.
 - 2.3.3. The guidance system must be fitted with low friction guides, insensitive to off-axis loading, that allow the impactor to move only in the specified direction of impact, when in contact with the vehicle. The guides must prevent motion in other directions including rotation about any axis.
 - 2.3.4. The impactor must be certified with previously unused foam.
 - 2.3.5. The impactor foam must not be excessively handled or deformed before, during or after fitting.

Changes to legislation: There are currently no known outstanding effects for the Commission Decision of 20 March 2006 on the detailed technical requirements for carrying out the tests specified in Directive 2005/66/EC of the European Parliament and of the Council relating to the use of frontal protection systems on motor vehicles (notified under document number C(2006) 776) (Text with EEA relevance) (2006/368/EC). (See end of Document for details)

2.3.6. The certification impactor must be propelled horizontally at a velocity of $7,5 \pm 0,1$ m/s into the stationary impactor as shown in Figure 20. The certification impactor must be positioned so that its centreline aligns with a position on the tibia centreline of 50 mm from the centre of the knee, with tolerances of ± 3 mm laterally and ± 3 mm vertically.

3. UPPER LEGFORM IMPACTOR **U.K.**

3.1. The upper legform impactor must meet the requirements specified in paragraph 3.3 when tested in accordance with paragraph 3.4.

3.2. The stabilised temperature of the impactor during certification must be $20^\circ \pm 2^\circ \text{C}$.

3.3. Requirements **U.K.**

3.3.1. When the impactor is propelled into a stationary cylindrical pendulum the peak force measured in each load transducer must be not less 1,20 kN and not more than 1,55 kN and the difference between the peak forces measured in the top and bottom load transducers must not be more than 0,10 kN. The peak bending moment measured by the strain gauges must not be less than 190 Nm and not more than 250 Nm on the centre position and not less than 160 Nm and not more than 220 Nm for the outer positions. The difference between the upper and lower peak bending moments must not be more than 20 Nm.

3.3.2. For all these values the readings used must be from the initial impact with the pendulum and not from the arresting phase. Any system used to arrest the impactor or pendulum must be so arranged that the arresting phase does not overlap in time with the initial impact. The arresting system must not cause the transducer outputs to exceed the specified CAC.

3.3.3. The instrumentation response value CFC, as defined in ISO 6487:2000, must be 180 for all transducers. The CAC response values, as defined in ISO 6487:2000, must be 10 kN for the force transducers and 1000 Nm for the bending moment measurements.

3.4. Test procedure **U.K.**

3.4.1. The impactor must be mounted to the propulsion and guidance system, by a torque limiting joint. The torque limiting joint must be set so that the longitudinal axis of the front member is perpendicular to the axis of the guidance system, with a tolerance of $\pm 2^\circ$, with the joint friction torque set to a minimum of 650 Nm. The guidance system must be fitted with low friction guides that allow the impactor to move only in the specified direction of impact, when in contact with the pendulum.

3.4.2. The impactor mass must be adjusted to give a mass of $12 \pm 0,1$ kg, this mass includes those propulsion and guidance components which are effectively part of the impactor during impact.

3.4.3. The centre of gravity of those parts of the impactor which are effectively forward of the torque limiting joint, including the extra weights fitted, must lie on the longitudinal centreline of the impactor, with a tolerance of ± 10 mm.

3.4.4. The impactor must be certified with previously unused foam.

3.4.5. The impactor foam must not be excessively handled or deformed before, during or after fitting.

3.4.6. The impactor with the front member vertical must be propelled horizontally at a velocity of $7,1 \pm 0,1$ m/s into the stationary pendulum as shown in Figure 22.

Changes to legislation: There are currently no known outstanding effects for the Commission Decision of 20 March 2006 on the detailed technical requirements for carrying out the tests specified in Directive 2005/66/EC of the European Parliament and of the Council relating to the use of frontal protection systems on motor vehicles (notified under document number C(2006) 776) (Text with EEA relevance) (2006/368/EC). (See end of Document for details)

- 3.4.7. The pendulum tube must have an outside diameter of 150^{+1}_{-4} mm, a wall thickness of $3 \pm 0,15$ mm and a mass of $3 \pm 0,03$ kg. Total pendulum tube length must be 275 ± 25 mm. The pendulum tube must be made from cold finished seamless steel (metal surface plating is permissible for protection from corrosion), with an outer surface finish of better than 2,0 micrometers. It must be suspended on two wire ropes of $1,5 \pm 0,2$ mm diameter and of 2,0 m minimum length. The surface of the pendulum must be clean and dry. The pendulum tube must be positioned so that the longitudinal axis of the cylinder is perpendicular to the front member (i.e. level), with a tolerance of $\pm 2^\circ$, and to the direction of impactor motion, with a tolerance of $\pm 2^\circ$, and with the centre of the pendulum tube aligned with the centre of the impactor front member, with tolerances of ± 5 mm laterally and ± 5 mm vertically.

4. HEADFORM IMPACTOR **U.K.**

- 4.1. The child/small adult headform impactor must meet the requirements specified in paragraph 4.3 when tested in accordance with paragraph 4.4.
- 4.2. The stabilised temperature of the impactor during certification must be $20^\circ \pm 2^\circ\text{C}$.
- 4.3. Requirements **U.K.**
- 4.3.1. When the child/small adult headform impactor is impacted by a linearly guided certification impactor, as specified in paragraph 4.4, the peak resultant acceleration measured by one tri-axial (or three uni-axial) accelerometer in the headform must be not less than 290 g and not more than 350 g. The resultant acceleration time curve must be uni-modal.
- 4.3.2. The instrumentation response value CFC, as defined in ISO 6487:2000, must be 1000. The CAC response value, as defined in ISO 6487:2000, must be 1 000 g for the acceleration.
- 4.4. Test procedure **U.K.**
- 4.4.1. The headform impactor must be suspended as shown in Figure 23. The headform impactor must be suspended with the rear face at an angle between 25° and 90° with the horizontal, as shown in Figure 23.
- 4.4.2. The certification impactor must have a mass of $1,0 \pm 0,01$ kg. This mass includes those propulsion and guidance components which are effectively part of the impactor during impact. The linear guidance system must be fitted with low friction guides which do not contain any rotating parts. The diameter of the flat impactor face must be 70 ± 1 mm, while the edge must be rounded by a $5 \pm 0,5$ mm radius. The face of the certification impactor must be made of aluminium, with an outer surface finish of better than 2,0 micrometers.
- 4.4.3. The certification impactor must be propelled horizontally at a velocity of $7,0 \pm 0,1$ m/s into the stationary child/small adult headform impactor as shown in Figure 23. The certification impactor must be positioned so that the centre of gravity of the headform is located on the centre line of the certification impactor, with tolerances of ± 5 mm laterally and ± 5 mm vertically.
- 4.4.4. The test must be performed on three different impact positions on the headform impactor. Previously used and/or damaged skin must be tested in those specific areas.

Changes to legislation: There are currently no known outstanding effects for the Commission Decision of 20 March 2006 on the detailed technical requirements for carrying out the tests specified in Directive 2005/66/EC of the European Parliament and of the Council relating to the use of frontal protection systems on motor vehicles (notified under document number C(2006) 776) (Text with EEA relevance) (2006/368/EC). (See end of Document for details)

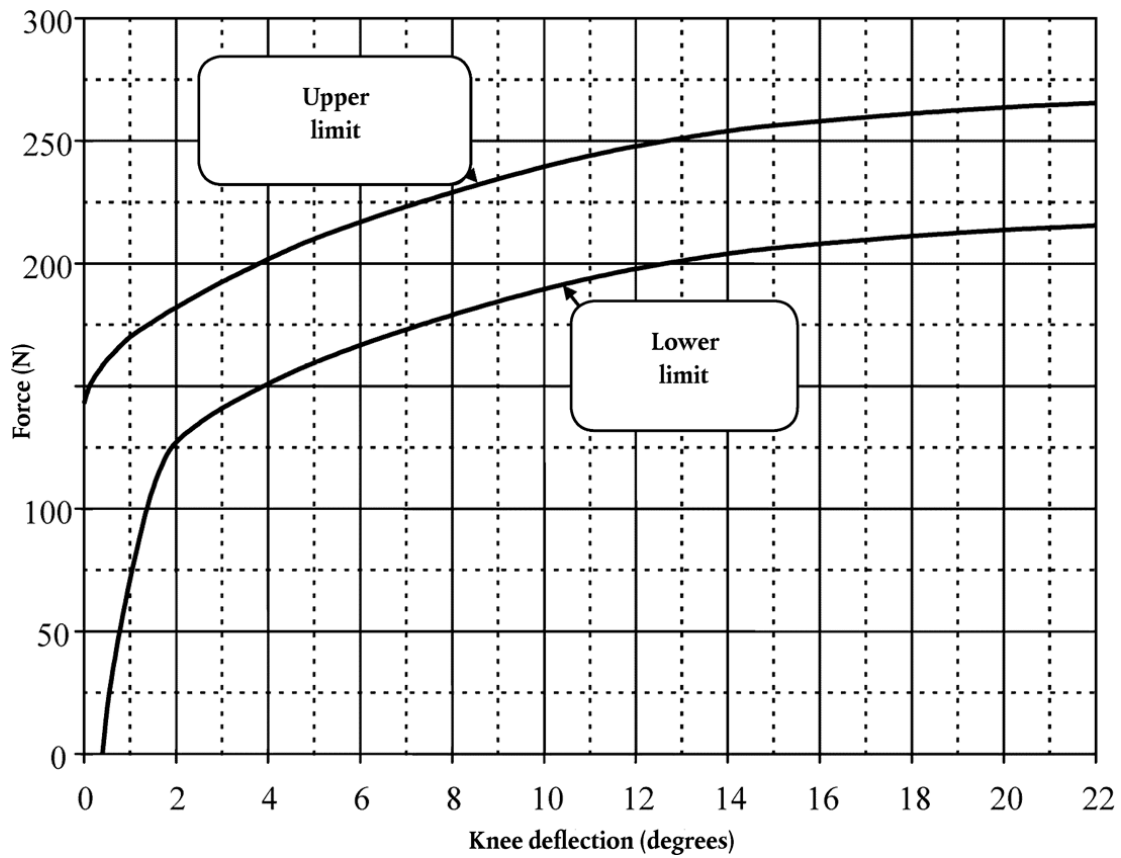

Changes to legislation: There are currently no known outstanding effects for the Commission Decision of 20 March 2006 on the detailed technical requirements for carrying out the tests specified in Directive 2005/66/EC of the European Parliament and of the Council relating to the use of frontal protection systems on motor vehicles (notified under document number C(2006) 776) (Text with EEA relevance) (2006/368/EC). (See end of Document for details)

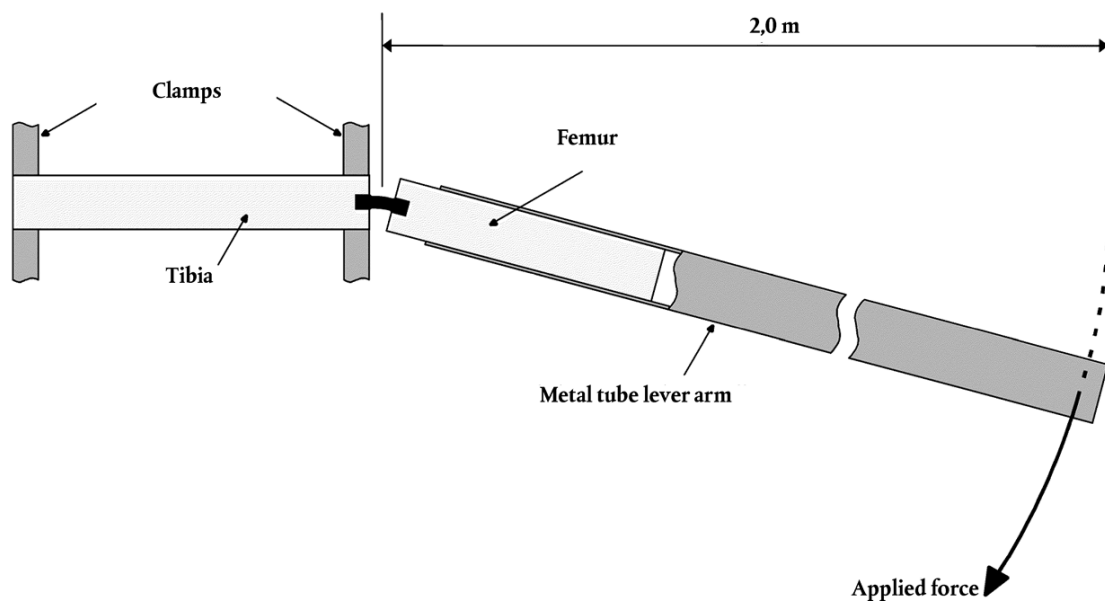
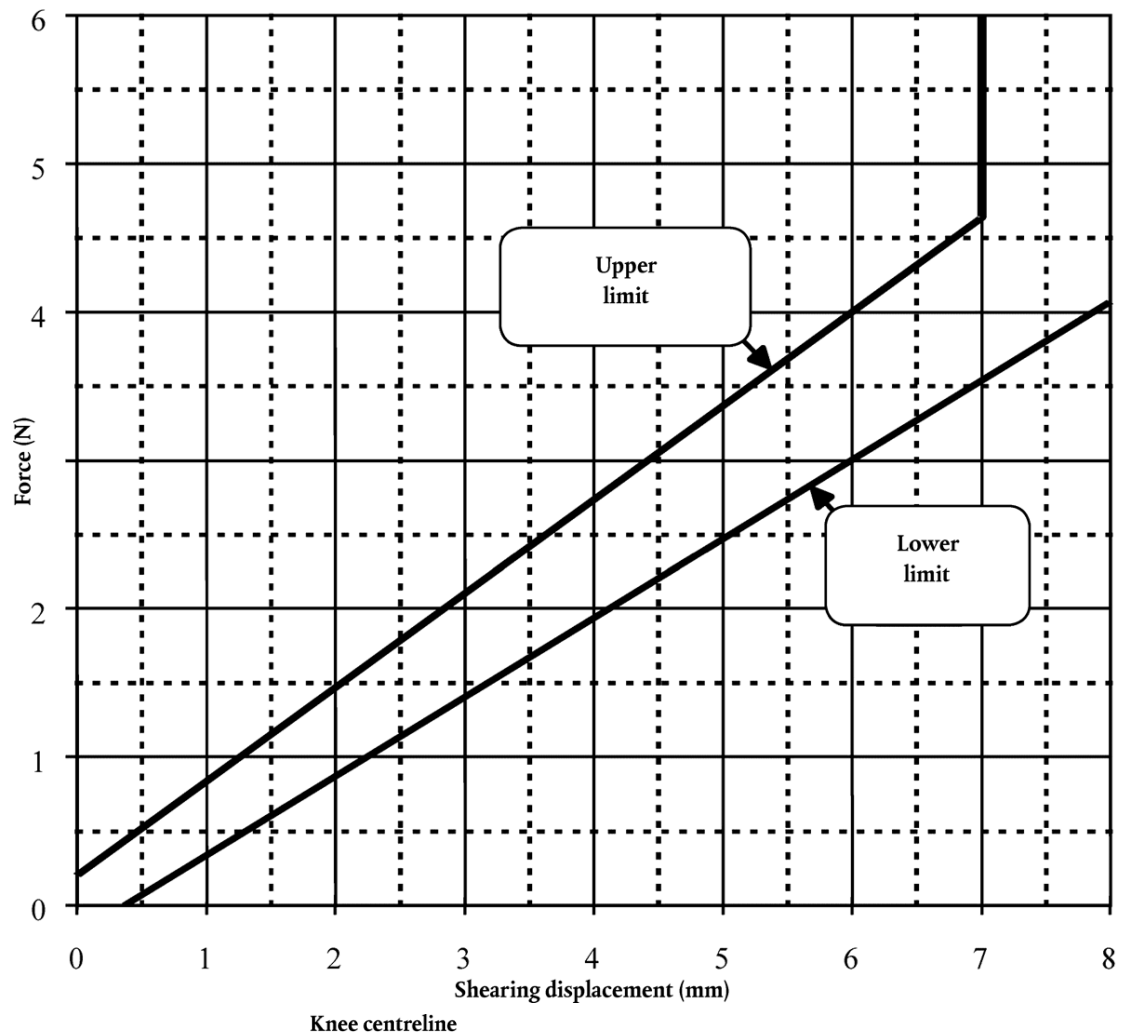

Changes to legislation: There are currently no known outstanding effects for the Commission Decision of 20 March 2006 on the detailed technical requirements for carrying out the tests specified in Directive 2005/66/EC of the European Parliament and of the Council relating to the use of frontal protection systems on motor vehicles (notified under document number C(2006) 776) (Text with EEA relevance) (2006/368/EC). (See end of Document for details)

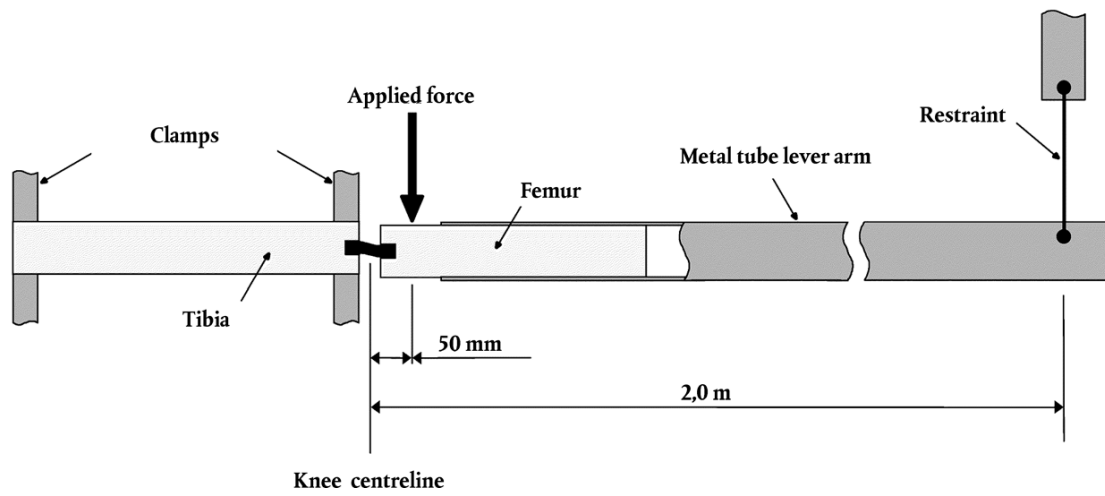

Changes to legislation: There are currently no known outstanding effects for the Commission Decision of 20 March 2006 on the detailed technical requirements for carrying out the tests specified in Directive 2005/66/EC of the European Parliament and of the Council relating to the use of frontal protection systems on motor vehicles (notified under document number C(2006) 776) (Text with EEA relevance) (2006/368/EC). (See end of Document for details)

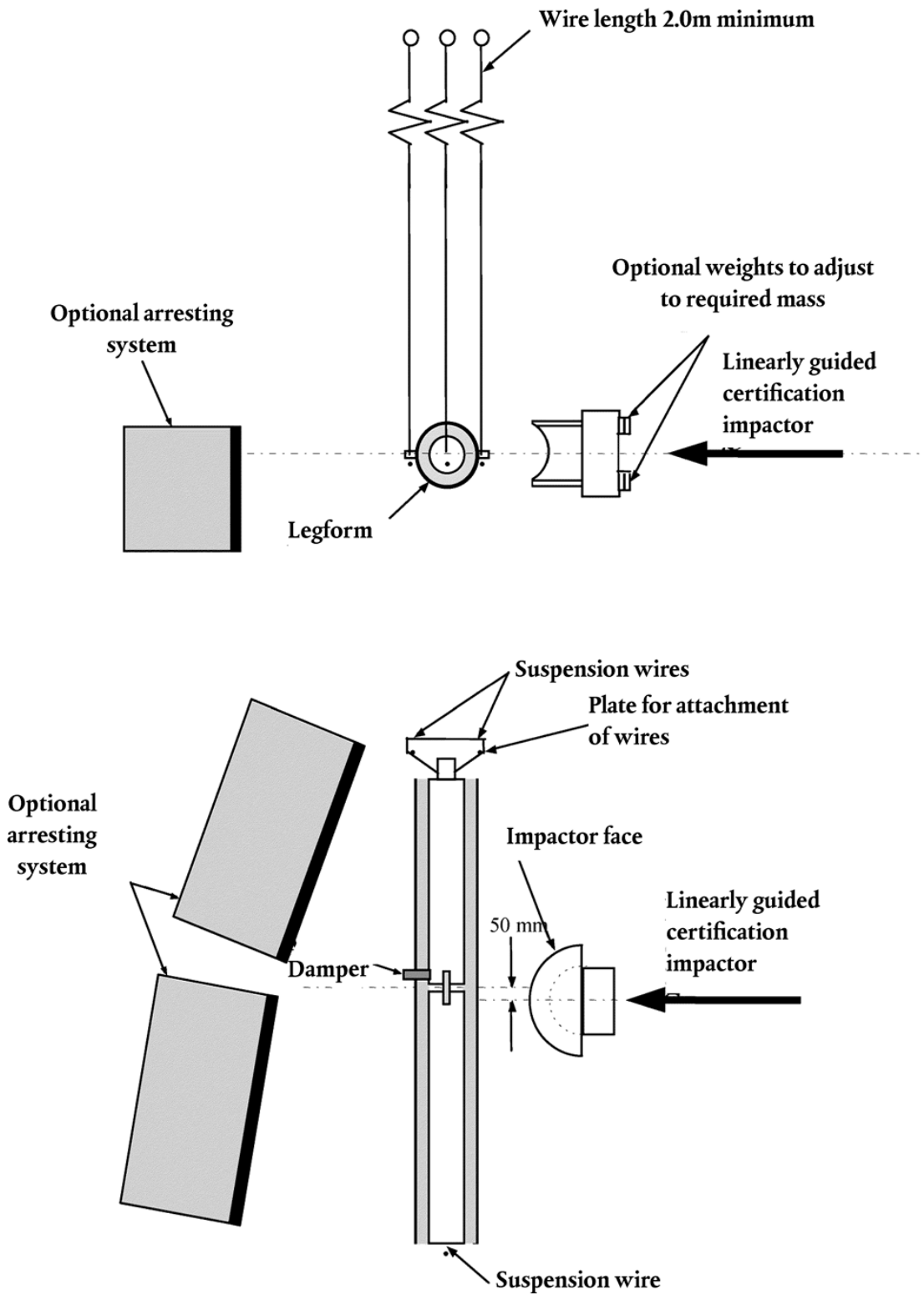

Changes to legislation: There are currently no known outstanding effects for the Commission Decision of 20 March 2006 on the detailed technical requirements for carrying out the tests specified in Directive 2005/66/EC of the European Parliament and of the Council relating to the use of frontal protection systems on motor vehicles (notified under document number C(2006) 776) (Text with EEA relevance) (2006/368/EC). (See end of Document for details)

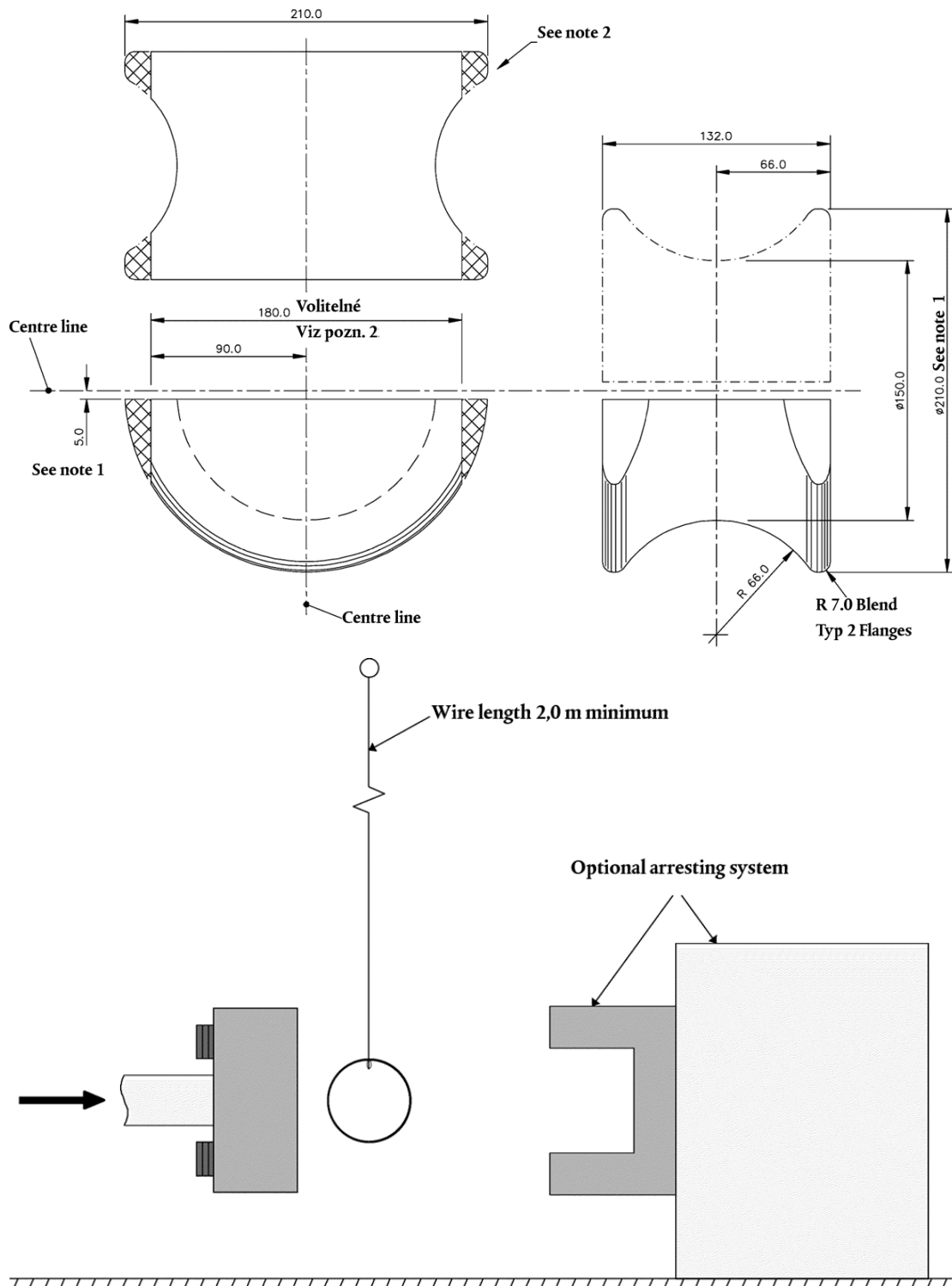

Changes to legislation: There are currently no known outstanding effects for the Commission Decision of 20 March 2006 on the detailed technical requirements for carrying out the tests specified in Directive 2005/66/EC of the European Parliament and of the Council relating to the use of frontal protection systems on motor vehicles (notified under document number C(2006) 776) (Text with EEA relevance) (2006/368/EC). (See end of Document for details)

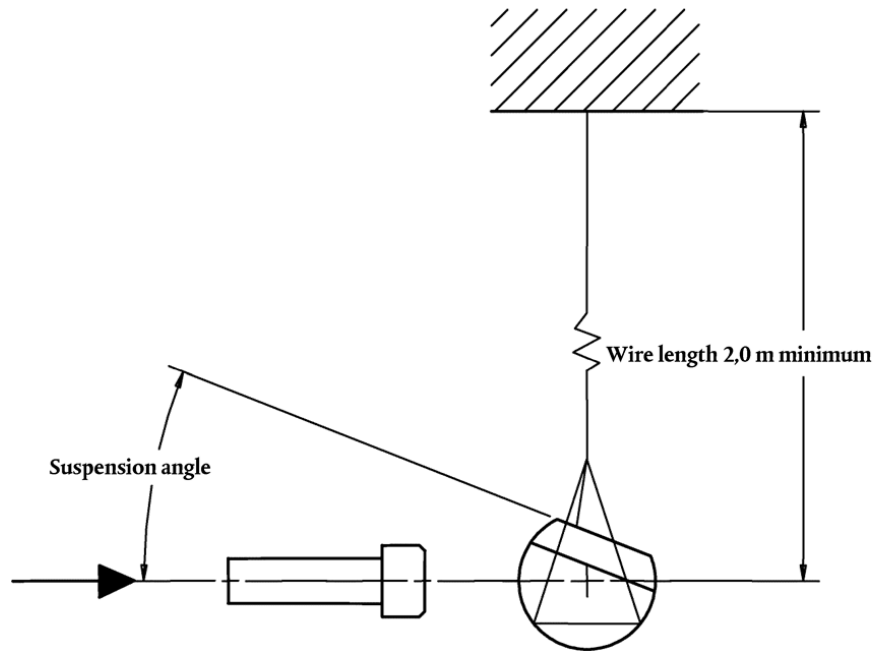

Changes to legislation: There are currently no known outstanding effects for the Commission Decision of 20 March 2006 on the detailed technical requirements for carrying out the tests specified in Directive 2005/66/EC of the European Parliament and of the Council relating to the use of frontal protection systems on motor vehicles (notified under document number C(2006) 776) (Text with EEA relevance) (2006/368/EC). (See end of Document for details)

- (1) OJ L 309, 25.11.2005, p. 37.

Changes to legislation:

There are currently no known outstanding effects for the Commission Decision of 20 March 2006 on the detailed technical requirements for carrying out the tests specified in Directive 2005/66/EC of the European Parliament and of the Council relating to the use of frontal protection systems on motor vehicles (notified under document number C(2006) 776) (Text with EEA relevance) (2006/368/EC).