

This document is meant purely as a documentation tool and the institutions do not assume any liability for its contents

► **B**

**COMMISSION DECISION**

**of 28 July 2006**

**concerning the technical specification of interoperability relating to the subsystem ‘rolling stock — freight wagons’ of the trans-European conventional rail system**

*(notified under document number C(2006) 3345)*

**(Text with EEA relevance)**

(2006/861/EC)

(OJ L 344, 8.12.2006, p. 1)

Amended by:

		Official Journal		
		No	page	date
► <b><u>M1</u></b>	Commission Decision 2009/107/EC of 23 January 2009	L 45	1	14.2.2009



**COMMISSION DECISION**

**of 28 July 2006**

**concerning the technical specification of interoperability relating to the subsystem ‘rolling stock — freight wagons’ of the trans-European conventional rail system**

*(notified under document number C(2006) 3345)*

**(Text with EEA relevance)**

(2006/861/EC)

THE COMMISSION OF THE EUROPEAN COMMUNITIES,

Having regard to the Treaty establishing the European Community,

Having regard to Directive 2001/16/EC of 19 March 2001 of the European Parliament and of the Council on the interoperability of the conventional rail system <sup>(1)</sup>, and in particular Article 6(1) thereof,

Whereas:

- (1) In accordance with Article 2(c) of Directive 2001/16/EC, the trans-European conventional rail system is subdivided into structural and functional subsystems.
- (2) In accordance with Article 23(1) of the Directive, the subsystem ‘rolling stock — freight wagons’ needs to be covered by a technical specification for interoperability (TSI).
- (3) The first step in establishing a TSI is to have a draft TSI drawn up by the European Association for Railway Interoperability (AEIF) which was appointed as the joint representative body.
- (4) The AEIF has been given a mandate to draw up a draft TSI for the ‘rolling stock — freight wagons’ subsystem in accordance with Article 6(1) of Directive 2001/16/EC. The basic parameters for this draft TSI were adopted by Commission Decision 2004/446/EC of 29 April 2004 specifying the basic parameters of the Noise, Freight Wagons and Telematics applications for freight Technical Specifications for Interoperability referred to in Directive 2001/16/EC <sup>(2)</sup>.
- (5) The draft TSI set up on the basis of the basic parameters was accompanied by an introductory report containing a cost-benefit analysis as provided for in Article 6(5) of the Directive.
- (6) The draft TSIs have been examined by the Committee set up by Council Directive 96/48/EC of 23 July 1996 on the interoperability of the trans-European high-speed rail system <sup>(3)</sup> and referred to in Article 21 of Directive 2001/16/EC, in the light of the introductory report.
- (7) Directive 2001/16/EC and the TSIs do apply to renewals but not to maintenance-related replacements. However Member States are encouraged, when they are able to do so and where it is justified by the scope of the maintenance-related work, to apply the TSIs to maintenance-related replacements.
- (8) The putting into service of new, renewed or upgraded wagons must also take into full consideration the impact on the environment; this includes the impact of noise. It is therefore important that the implementation of the TSI being the subject

<sup>(1)</sup> OJ L 110, 20.4.2001, p. 1. Directive as amended by Directive 2004/50/EC of the European Parliament and of the Council (OJ L 164, 30.4.2004, p. 114, corrected by OJ L 220, 21.6.2004, p. 40).

<sup>(2)</sup> OJ L 155, 30.4.2004, p. 1, corrected by OJ L 193, 1.6.2004, p. 1

<sup>(3)</sup> OJ L 235, 17.9.1996, p. 6. Directive as last amended by Directive 2004/50/EC.

**▼B**

of this Decision is carried out in conjunction with the requirements of the Noise TSI, to the extent that the Noise TSI applies to freight wagons.

- (9) In its current version the TSI does not fully deal with all aspects of interoperability; the items which are not dealt with are classified as 'Open Points' in Annex JJ of the TSI. Given that the verification of interoperability has to be established by reference to the requirements of the TSIs, in accordance with Article 16(2) of Directive 2001/16/EC, it is necessary, during the transition period between the publication of this Decision and the full implementation of the attached TSI, to lay down the conditions to be complied with in addition to those explicitly referred to in the TSI attached.
- (10) Individual Member States are to inform the other Member States and the Commission of the relevant national technical rules in use for achieving interoperability and meeting the essential requirements of Directive 2001/16/EC as well as of the bodies it appoints for carrying out the procedure for the assessment of conformity or suitability for use as well as the checking procedure in use for verifying the interoperability of subsystems within the meaning of Article 16(2) of Directive 2001/16/EC. For this latter purpose, Member States should apply, as far as possible, the principles and criteria provided for in Directive 2001/16/EC for the implementation of Article 16(2) in making use of the bodies notified under Article 20 of Directive 2001/16/EC. The Commission should carry out an analysis of the information forwarded by the Member States, in the form of national rules, procedures, bodies in charge of implementing procedures, and duration of these procedures, and, where appropriate, should discuss with the Committee the need for the adoption of any measures.
- (11) The TSI in question should not demand the use of specific technologies or technical solutions except where this is strictly necessary for the interoperability of the trans-European conventional rail system.
- (12) The TSI is based on best available expert knowledge at the time of preparation of the relevant draft. Developments in technology, operational, safety or social requirements may make it necessary to amend or supplement this TSI. Where applicable, a review or updating procedure should be initiated in accordance with Article 6(3) of Directive 2001/16/EC.
- (13) To encourage innovation and in order to take into account the experience acquired, the attached TSI should be subject to a periodical revision at regular intervals.
- (14) Where innovative solutions are proposed the manufacturer or the contracting entity shall state the deviation from the relevant section of the TSI. The European Rail Agency will finalise the appropriate functional and interface specifications of the solution and develop the assessment methods.
- (15) Freight wagons currently operate under existing national, bilateral, multinational or international agreements. It is important that those agreements do not hinder current and future progress towards interoperability. To this end, it is necessary that the Commission examine those agreements in order to determine whether the TSI presented in this Decision needs to be revised accordingly.
- (16) In order to avoid any confusion, it is necessary to state that the provisions of Decision 2004/446/EC which concern the basic parameters of the trans-European conventional rail system shall not apply anymore.

**▼B**

- (17) The provisions of this Decision are in conformity with the opinion of the Committee set up by Article 21 of Directive 96/48/EC,

HAS ADOPTED THIS DECISION:

*Article 1*

A Technical Specification for Interoperability (TSI) relating to the 'rolling stock — freight wagons' subsystem of the trans-European conventional system referred to in Article 6(1) of Directive 2001/16/EC is hereby adopted by the Commission.

The TSI shall be as set out in the Annex to this Decision.

The TSI shall be fully applicable to the freight wagon rolling stock of the trans-European conventional rail system as defined in Annex I to Directive 2001/16/EC, account being taken of Articles 2 and 3 of this Decision.

**▼M1***Article 1a***Technical Documents**

1. The European Railway Agency (ERA) shall publish on its website the content of Annex LL as an ERA Technical Document.
2. The ERA shall publish on its website the list of fully approved composite brake-blocks for international transport referred to in Annexes P and JJ as an ERA Technical Document.
3. The Agency shall publish on its website the additional specifications related to the draw gear referred to in Annex JJ as an ERA Technical Document.
4. The Agency shall keep the Technical Documents referred to in paragraphs 1 to 3 up to date and inform the Commission of any revised version. The Commission shall inform the Member States through the Committee established under Article 29 of Directive 2008/57/EC. Should the Commission or a Member State consider that a Technical Document does not meet the requirements of Directive 2008/57/EC or of any other Community legislation, the matter shall be discussed in the Committee. On the basis of the Committee's deliberations and upon request of the Commission, the Technical Documents shall be withdrawn or modified by the Agency.

**▼B***Article 2*

1. With regard to those issues classified as 'Open points' set out in Annex JJ of the TSI, the conditions to be complied with for the verification of the interoperability pursuant to Article 16(2) of Directive 2001/16/EC shall be those applicable technical rules in use in the Member State which authorise the putting into service of the subsystem covered by this Decision.
2. Each Member State shall notify to the other Member States and to the Commission within six months of the notification of this Decision:
  - (a) the list of the applicable technical rules mentioned in paragraph 1;
  - (b) the conformity assessment and checking procedures to be applied with regard to the application of these rules;
  - (c) the bodies it appoints for carrying out those conformity-assessment and checking procedures.

**▼B***Article 3*

Member States shall notify the following types of agreement to the Commission within six months of the entry into force of the attached TSI:

- (a) national, bilateral or multilateral agreements between Member States and railway undertakings or infrastructure managers, agreed on either a permanent or a temporary basis and necessitated by the very specific or local nature of the intended transport service;
- (b) bilateral or multilateral agreements between railway undertakings, infrastructure managers or safety authorities which deliver significant levels of local or regional interoperability;
- (c) international agreements between one or more Member States and at least one third country, or between railway undertakings or infrastructure managers of Member States and at least one railway undertaking or infrastructure manager of a third country which deliver significant levels of local or regional interoperability.

*Article 4*

Those provisions of Decision 2004/446/EC which concern the basic parameters of the trans-European conventional rail system shall no longer apply as from the date on which this Decision becomes applicable.

*Article 5*

This Decision shall become applicable six months after the date of its notification.

*Article 6*

This Decision is addressed to the Member States.



## ANNEX

**Technical Specification for Interoperability relating to the subsystem Rolling Stock — Freight Wagons**

1. **Introduction**
  - 1.1. TECHNICAL SCOPE
  - 1.2. GEOGRAPHICAL SCOPE
  - 1.3. CONTENT OF THIS TSI
2. **Definition of subsystem/scope**
  - 2.1. DEFINITION OF SUBSYSTEM
  - 2.2. FUNCTIONS OF SUBSYSTEM
  - 2.3. INTERFACES OF SUBSYSTEM
3. **Essential requirements**
  - 3.1. GENERAL
  - 3.2. THE ESSENTIAL REQUIREMENTS RELATE TO:
  - 3.3. GENERAL REQUIREMENTS
    - 3.3.1. *Safety*
    - 3.3.2. *Reliability and availability*
    - 3.3.3. *Health*
    - 3.3.4. *Environmental protection*
    - 3.3.5. *Technical compatibility*
  - 3.4. REQUIREMENTS SPECIFIC TO THE ROLLING STOCK SUBSYSTEM
    - 3.4.1. *Safety*
    - 3.4.2. *Reliability and availability*
    - 3.4.3. *Technical compatibility*
  - 3.5. REQUIREMENTS SPECIFIC TO MAINTENANCE
    - 3.5.1. *Health and safety*
    - 3.5.2. *Environmental protection*
    - 3.5.3. *Technical compatibility*
  - 3.6. REQUIREMENTS SPECIFIC TO OTHER SUBSYSTEMS CONCERNING ALSO THE ROLLING STOCK SUBSYSTEM
    - 3.6.1. *Infrastructure Subsystem*
      - 3.6.1.1. Safety
    - 3.6.2. *Energy Subsystem*
      - 3.6.2.1. Safety
      - 3.6.2.2. Environmental protection
      - 3.6.2.3. Technical compatibility
    - 3.6.3. *Control and command and signalling*
      - 3.6.3.1. Safety
      - 3.6.3.2. Technical compatibility
    - 3.6.4. *Operation and traffic management*
      - 3.6.4.1. Safety
      - 3.6.4.2. Reliability and availability
      - 3.6.4.3. Technical compatibility
    - 3.6.5. *Telematics applications for freight and passengers*
      - 3.6.5.1. Technical compatibility
      - 3.6.5.2. Reliability and availability
      - 3.6.5.3. Health
      - 3.6.5.4. Safety

**▼B**

- 4. **Characterisation of the subsystem**
- 4.1. INTRODUCTION
- 4.2. FUNCTIONAL AND TECHNICAL SPECIFICATIONS OF THE SUBSYSTEM
  - 4.2.1. *General*
  - 4.2.2. *Structures and mechanical parts:*
    - 4.2.2.1. Interface (e. g. Coupling) between vehicles, between set of vehicles and between trains
      - 4.2.2.1.1. General
      - 4.2.2.1.2. Functional and technical specifications
        - 4.2.2.1.2.1. Buffers
        - 4.2.2.1.2.2. Draw Gear
        - 4.2.2.1.2.3. Interaction of draw- and buffing-gear
      - 4.2.2.2. Safe access and egress for rolling stock
      - 4.2.2.3. Strength of Main Vehicle Structure and Securing of Freight
        - 4.2.2.3.1. General
        - 4.2.2.3.2. Exceptional Loads
          - 4.2.2.3.2.1. Longitudinal Design Loads
          - 4.2.2.3.2.2. Maximum Vertical Load
          - 4.2.2.3.2.3. Load combinations
          - 4.2.2.3.2.4. Lifting and Jacking
          - 4.2.2.3.2.5. Equipment Attachment (Including body/bogie)
          - 4.2.2.3.2.6. Other Exceptional Loads
        - 4.2.2.3.3. Service (fatigue) Loads
          - 4.2.2.3.3.1. Sources of load input.
          - 4.2.2.3.3.2. Demonstration of fatigue strength
        - 4.2.2.3.4. Stiffness of the main vehicle structure
          - 4.2.2.3.4.1. Deflections
          - 4.2.2.3.4.2. Modes of vibration
          - 4.2.2.3.4.3. Torsional stiffness
          - 4.2.2.3.4.4. Equipment
      - 4.2.2.3.5. Securing of Freight
    - 4.2.2.4. Doors closing and locking
    - 4.2.2.5. Marking of freight wagons
    - 4.2.2.6. Dangerous goods
      - 4.2.2.6.1. General
      - 4.2.2.6.2. Legislation applicable to rolling stock for the transport of dangerous goods
      - 4.2.2.6.3. Additional legislation applicable to tanks
      - 4.2.2.6.4. Maintenance rules
  - 4.2.3. *Vehicle track interaction and gauging*
    - 4.2.3.1. Kinematic gauge
    - 4.2.3.2. Static axle load and linear load
    - 4.2.3.3. Rolling stock parameters which influence ground based train monitoring systems
      - 4.2.3.3.1. Electrical resistance:
      - 4.2.3.3.2. Hot axle box detection
    - 4.2.3.4. Vehicle dynamic behaviour
      - 4.2.3.4.1. General
      - 4.2.3.4.2. Functional and technical specifications

**▼B**

- 4.2.3.4.2.1. Safety against derailment and running stability
- 4.2.3.4.2.2. Safety against derailment when running on twisted tracks
- 4.2.3.4.2.3. Maintenance rules
- 4.2.3.4.2.4. Suspension
- 4.2.3.5. Longitudinal compressive forces
- 4.2.3.5.1. General
- 4.2.3.5.2. Functional and technical specifications
- 4.2.4. *Braking*
- 4.2.4.1. Braking performance
- 4.2.4.1.1. General
- 4.2.4.1.2. Functional and Technical Specification
- 4.2.4.1.2.1. Control train line
- 4.2.4.1.2.2. Braking Performance elements
- 4.2.4.1.2.3. Mechanical components
- 4.2.4.1.2.4. Energy storage
- 4.2.4.1.2.5. Energy limits:
- 4.2.4.1.2.6. Wheel slide protection (WSP)
- 4.2.4.1.2.7. Air-supply
- 4.2.4.1.2.8. Parking Brake
- 4.2.5. *Communication*
- 4.2.5.1. Vehicle capability to transmit information from vehicle to vehicle
- 4.2.5.2. Vehicle capability to transmit information between ground and vehicle
- 4.2.5.2.1. General
- 4.2.5.2.2. Functional and technical specification
- 4.2.5.2.3. Maintenance rules
- 4.2.6. *Environmental conditions*
- 4.2.6.1. Environmental conditions
- 4.2.6.1.1. General
- 4.2.6.1.2. Functional and technical specifications
- 4.2.6.1.2.1. Altitude
- 4.2.6.1.2.2. Temperature
- 4.2.6.1.2.3. Humidity
- 4.2.6.1.2.4. Air movement
- 4.2.6.1.2.5. Rain
- 4.2.6.1.2.6. Snow, ice and hail
- 4.2.6.1.2.7. Solar radiation
- 4.2.6.1.2.8. Resistance to Pollution
- 4.2.6.2. Aerodynamic effects
- 4.2.6.3. Cross winds
- 4.2.7. *System protection*
- 4.2.7.1. Emergency Measures
- 4.2.7.2. Fire safety
- 4.2.7.2.1. General
- 4.2.7.2.2. Functional and technical specification
- 4.2.7.2.2.1. Definitions
- 4.2.7.2.2.2. Normative References
- 4.2.7.2.2.3. Design rules
- 4.2.7.2.2.4. Material requirement



**▼ B**

- 4.2.7.2.2.5. Maintenance of the fire protection measures
- 4.2.7.3. Electrical protection
  - 4.2.7.3.1. General
  - 4.2.7.3.2. Functional and technical specifications
    - 4.2.7.3.2.1. Freight wagon bonding
    - 4.2.7.3.2.2. Freight wagon electrical equipment bonding
  - 4.2.7.4. Fixing of tail lamps
    - 4.2.7.4.1. General
    - 4.2.7.4.2. Functional and technical specifications
      - 4.2.7.4.2.1. Characteristics
      - 4.2.7.4.2.2. Position
  - 4.2.7.5. Provisions for the hydraulic/pneumatic equipment of freight wagons
    - 4.2.7.5.1. General
    - 4.2.7.5.2. Functional and technical specifications
- 4.2.8. *Maintenance: Maintenance file*
  - 4.2.8.1. Definition, contents and criteria of the Maintenance File
    - 4.2.8.1.1.1. Maintenance File
    - 4.2.8.1.2. Management of the Maintenance File.
- 4.3 FUNCTIONAL AND TECHNICAL SPECIFICATIONS OF THE INTERFACES
  - 4.3.1. *General*
  - 4.3.2. *Control and command and signalling subsystem –*
    - 4.3.2.1. Static axle load, dynamic wheel load and linear load (section 4.2.3.2)
    - 4.3.2.2. Wheels
    - 4.3.2.3. Rolling stock parameters which influence ground based train monitoring systems
    - 4.3.2.4. Braking
      - 4.3.2.4.1. Braking performance
  - 4.3.3. *Traffic operation and management subsystem*
    - 4.3.3.1. Interface between vehicles, between sets of vehicles and between trains
    - 4.3.3.2. Doors closing and locking
    - 4.3.3.3. Securing of freight
    - 4.3.3.4. Marking of freight wagons.
    - 4.3.3.5. Dangerous goods
    - 4.3.3.6. Longitudinal compressive forces
    - 4.3.3.7. Braking performance
    - 4.3.3.8. Communication
      - 4.3.3.8.1. Vehicle Capability to transmit information between ground and vehicle
    - 4.3.3.9. Environmental Conditions
    - 4.3.3.10. Aerodynamic effects
    - 4.3.3.11. Cross winds
    - 4.3.3.12. Emergency Measures
    - 4.3.3.13. Fire Safety
  - 4.3.4. *Telematics applications for freight services subsystem*
  - 4.3.5. *Infrastructure subsystem*
    - 4.3.5.1. Interface between vehicles, between sets of vehicles and between trains
    - 4.3.5.2. Strength of Main Vehicle Structure and Securing of Freight

**▼B**

- 4.3.5.3. Kinematic gauge
- 4.3.5.4. Static axle load, dynamic wheel load and linear load
- 4.3.5.5. Vehicle dynamic behaviour
- 4.3.5.6. Longitudinal compressive forces
- 4.3.5.7. Environmental Conditions
- 4.3.5.8. Fire protection
- 4.3.6. *Energy subsystem*
- 4.3.7. *The Council Directive 96/49/EC and its Annex (RID).*
- 4.3.7.1. Dangerous goods
- 4.3.8. *Conventional Rail Noise TSI*
- 4.4. OPERATING RULES
- 4.5. MAINTENANCE RULES
- 4.6. PROFESSIONAL QUALIFICATIONS
- 4.7. HEALTH AND SAFETY CONDITIONS
- 4.8. INFRASTRUCTURE AND ROLLING STOCK REGISTERS
- 4.8.1. *Infrastructure Register*
- 4.8.2. *Rolling Stock Register*
- 5. **Interoperability constituents**
- 5.1. DEFINITION
- 5.2. INNOVATIVE SOLUTIONS
- 5.3. LIST OF CONSTITUENTS
- 5.3.1. *Structures and mechanical parts*
- 5.3.1.1. Buffers
- 5.3.1.2. Draw gear
- 5.3.1.3. Decals for Markings
- 5.3.2. *Vehicle track interaction and gauging*
- 5.3.2.1. Bogie and Running Gear
- 5.3.2.2. Wheelsets
- 5.3.2.3. Wheels
- 5.3.2.4. Axles
- 5.3.3. *Braking*
- 5.3.3.1. Distributor
- 5.3.3.2. Relay valve for variable load/Automatic empty-load change over brake
- 5.3.3.3. Wheel slide protection device
- 5.3.3.4. Slack adjuster
- 5.3.3.5. Brake cylinder/actuator
- 5.3.3.6. Pneumatic half coupling
- 5.3.3.7. End Cock
- 5.3.3.8. Isolating device for distributor
- 5.3.3.9. Brake pad
- 5.3.3.10. Brake blocks
- 5.3.3.11. Brake Pipe Emptying Accelerator valve
- 5.3.3.12. Automatic load sensing & empty/load changeover device
- 5.3.4. *Communication*
- 5.3.5. *Environmental conditions*
- 5.3.6. *System protection*
- 5.4. CONSTITUENTS PERFORMANCES AND SPECIFICATIONS
- 5.4.1. *Structures and mechanical parts*

**▼ B**

- 5.4.1.1. Buffers
- 5.4.1.2. Draw Gear
- 5.4.1.3. Decals for Markings
- 5.4.2. *Vehicle track interaction and gauging*
- 5.4.2.1. Bogie and Running Gear
- 5.4.2.2. Wheelsets
- 5.4.2.3. Wheels
- 5.4.2.4. Axles
- 5.4.3. *Braking*
- 5.4.3.1. Constituents approved at the time of publication of this TSI
- 5.4.3.2. Distributor
- 5.4.3.3. Relay valve for variable load/Automatic empty-load change over brake
- 5.4.3.4. Wheel slide protection device
- 5.4.3.5. Slack adjuster
- 5.4.3.6. Brake cylinder/actuator
- 5.4.3.7. Pneumatic half coupling
- 5.4.3.8. End Cock
- 5.4.3.9. Isolating device for distributor
- 5.4.3.10. Brake pad
- 5.4.3.11. Brake blocks
- 5.4.3.12. Brake Pipe Emptying Accelerator valve
- 5.4.3.13. Automatic load sensing & empty/load changeover device
- 6. **Assessment of conformity and/or suitability for use of the constituents and verification of the subsystem**
- 6.1. INTEROPERABILITY CONSTITUENTS
- 6.1.1. *Assessment procedures*
- 6.1.2. *Modules*
- 6.1.2.1. General
- 6.1.2.2. Existing solutions for Interoperability Constituents
- 6.1.2.3. Innovative solutions for Interoperability Constituents
- 6.1.2.4. Assessment of suitability for use
- 6.1.3. *Specification for assessment of ICs*
- 6.1.3.1. Structures and mechanical parts
- 6.1.3.1.1. Buffers
- 6.1.3.1.2. Draw Gear
- 6.1.3.1.3. Marking of Freight Wagons
- 6.1.3.2. Vehicle track interaction and gauging
- 6.1.3.2.1. Bogie and Running Gear
- 6.1.3.2.2. Wheelsets
- 6.1.3.2.3. Wheels
- 6.1.3.2.4. Axle
- 6.1.3.3. Braking
- 6.2. SUBSYSTEM CONVENTIONAL RAIL ROLLING STOCK FREIGHT WAGONS
- 6.2.1. *Assessment procedures*
- 6.2.2. *Modules*
- 6.2.2.1. General
- 6.2.2.2. Innovative solutions
- 6.2.2.3. Assessment of Maintenance

**▼B**

- 6.2.3. *Specifications for assessment of the subsystem*
- 6.2.3.1. Structures and Mechanical Parts
  - 6.2.3.1.1. Strength of main vehicle structure and Securing of Freight
  - 6.2.3.2. Vehicle track interaction and gauging
    - 6.2.3.2.1. Vehicle dynamic behaviour
      - 6.2.3.2.1.1. Application of the partial type approval procedure
      - 6.2.3.2.1.2. Certification of new wagons
      - 6.2.3.2.1.3. Exemptions from dynamic behaviour test for wagons to built or converted to run up to 100 km/h or 120 km/h
      - 6.2.3.2.1.4. Exemptions from stationary tests
    - 6.2.3.2.2. Longitudinal compressive forces for freight wagons with side buffers
    - 6.2.3.2.3. Measuring the freight wagons
    - 6.2.3.3. Braking
      - 6.2.3.3.1. Braking performance
      - 6.2.3.3.2. Minimum Brake System Testing
    - 6.2.3.4. Environmental conditions
      - 6.2.3.4.1. Temperature and other environmental conditions
        - 6.2.3.4.1.1. Temperature
        - 6.2.3.4.1.2. Other environmental conditions
      - 6.2.3.4.2. Aerodynamic effects
      - 6.2.3.4.3. Cross winds
- 7. **Implementation**
  - 7.1. GENERAL
  - 7.2. TSI REVISION
  - 7.3. APPLICATION OF THIS TSI TO NEW ROLLING STOCK
  - 7.4. EXISTING ROLLING STOCK
    - 7.4.1. *Application of this TSI to existing rolling stock*
    - 7.4.2. *Upgrading and renewal of existing freight wagons*
    - 7.4.3. *Additional requirements for wagon marking*
  - 7.5. WAGONS OPERATING UNDER NATIONAL, BILATERAL, MULTILATERAL OR INTERNATIONAL AGREEMENTS
    - 7.5.1. *Existing agreements*
    - 7.5.2. *Future agreements*
  - 7.6. AUTHORISATION FOR PLACING IN SERVICE OF TSI CONFORM WAGONS
  - 7.7. SPECIFIC CASES
    - 7.7.1. *Introduction*
    - 7.7.2. *List of specific cases*
      - 7.7.2.1. Structures and mechanical parts:
        - 7.7.2.1.1. Interface (e. g. Coupling) between vehicles, between set of vehicles and between trains
          - 7.7.2.1.1.1. Track gauge 1 524 mm
          - 7.7.2.1.1.2. Track gauge 1 520 mm
          - 7.7.2.1.1.3. Track gauge 1 520 mm/1 524 mm
          - 7.7.2.1.1.4. Track gauge 1 520 mm
          - 7.7.2.1.1.5. Track gauge 1 668 mm — Distance between buffers centrelines
          - 7.7.2.1.1.6. Interface between vehicles
          - 7.7.2.1.1.7. General specific case on the network of 1 000 mm or less

**▼B**

- 7.7.2.1.2. Safe access and egress for rolling stock
- 7.7.2.1.2.1. Safe access and egress for rolling stock Republic of Ireland and Northern Ireland
- 7.7.2.1.3. Strength of main vehicle structure and securing of freight
- 7.7.2.1.3.1. 1 520 mm gauge lines
- 7.7.2.1.3.2. 1 668 mm gauge lines — Lifting and jacking
- 7.7.2.2. Vehicle track interaction and gauging
- 7.7.2.2.1. Kinematic gauge
- 7.7.2.2.1.1. Kinematic gauge Great Britain
- 7.7.2.2.1.2. 1 520 mm and 1 435 mm track gauge wagons
- 7.7.2.2.1.3. Kinematic gauge Finland
- 7.7.2.2.1.4. Kinematic gauge Spain and Portugal
- 7.7.2.2.1.5. Kinematic gauge Ireland
- 7.7.2.2.2. Static axle load, dynamic wheel load and linear load
- 7.7.2.2.2.1. Static axle load, dynamic wheel load and linear load Finland
- 7.7.2.2.2.2. Static axle load, dynamic wheel load and linear load Great Britain
- 7.7.2.2.2.3. Static axle load, dynamic wheel load and linear load Lithuania, Latvia, Estonia
- 7.7.2.2.2.4. Static axle load, dynamic wheel load and linear load Republic of Ireland and Northern Ireland
- 7.7.2.2.3. Rolling stock parameters which influence ground based train monitoring systems
- 7.7.2.2.4. Vehicle dynamic behaviour
- 7.7.2.2.4.1. List of specific cases of wheel diameter related to various track gauges.
- 7.7.2.2.4.2. Material for wheels:
- 7.7.2.2.4.3. Specific loads cases:
- 7.7.2.2.4.4. Vehicle dynamic behaviour Spain and Portugal
- 7.7.2.2.4.5. Vehicle dynamic behaviour Republic of Ireland and Northern Ireland
- 7.7.2.2.5. Longitudinal compressive forces
- 7.7.2.2.5.1. Longitudinal compressive forces Poland and Slovakia in selected 1 520 mm lines, Lithuania, Latvia and Estonia
- 7.7.2.2.6. Bogie and Running Gear
- 7.7.2.2.6.1. Bogie and Running Gear Poland and Slovakia in selected 1 520 mm lines, Lithuania, Latvia, Estonia
- 7.7.2.2.6.2. Bogie and Running Gear Spain and Portugal
- 7.7.2.3. Braking
- 7.7.2.3.1. Braking performance
- 7.7.2.3.1.1. Braking performance Great Britain
- 7.7.2.3.1.2. Braking performance Poland and Slovakia in selected 1 520 mm lines, Lithuania, Latvia, Estonia
- 7.7.2.3.1.3. Braking performance Finland
- 7.7.2.3.1.4. Braking performance Spain and Portugal
- 7.7.2.3.1.5. Braking performance Finland, Sweden, Norway, Estonia, Latvia and Lithuania
- 7.7.2.3.1.6. Braking performance Republic of Ireland and Northern Ireland
- 7.7.2.3.2. Parking brake
- 7.7.2.3.2.1. Parking brake Great Britain
- 7.7.2.3.2.2. Parking brake Republic of Ireland and Northern Ireland
- 7.7.2.4. Environmental conditions
- 7.7.2.4.1. Environmental conditions

**▼B**

- 7.7.2.4.1.1. Environmental conditions Spain and Portugal
- 7.7.2.4.2. Fire safety
- 7.7.2.4.2.1. Fire safety Spain and Portugal
- 7.7.2.4.3. Electrical protection
- 7.7.2.4.3.1. Electrical protection Poland and Slovakia in selected 1 520 mm lines, Lithuania, Latvia, Estonia
- 7.7.3. *Table of specific cases arranged by Member State*



**Table of content: Annexes**

Reference	Title
A	Structures and mechanical parts
B	Structures and mechanical parts, Marking of freight wagons
C	Vehicle track interaction and gauging, Kinematic gauge
D	Vehicle track interaction and gauging, Static axle load, dynamic wheel load and linear load
E	Vehicle track interaction and gauging, Wheelset dimensions and tolerances for standard gauge
F	Communication, Vehicle capability to transmit information between ground and vehicle
G	Environmental conditions, Humidity
H	Infrastructure and Rolling stock register, Requirements for the freight wagons register
I	Braking, Interfaces of braking interoperability constituents
J	Vehicle track interaction and gauging, Bogie and running gear
K	Vehicle track interaction and gauging, Wheelset
L	Vehicle track interaction and gauging, Wheels
M	Vehicle track interaction and gauging, Axle
N	Structures and mechanical parts, Permissible stresses for static test methods
O	Environmental conditions, $T_{RJIV}$ requirements
P	Braking performance, assessment of interoperability constituents
Q	Assessment procedures, Interoperability Constituents
R	Vehicle track interaction and gauging, Longitudinal forces
S	Braking, Braking performance
T	Specific cases, Kinematic gauge, Great Britain
U	Specific cases, Kinematic gauge, 1 520 mm track gauge
V	Specific cases, Braking performance, Great Britain
W	Specific cases, Kinematic gauge, Finland, static gauge FIN1
X	Specific cases, Member States Spain and Portugal
Y	Constituents, Bogies and Running Gear
Z	Structures and mechanical parts, Impact (Buffing) Test
AA	Assessment procedures, Verification of Subsystems
BB	Structures and mechanical parts, Fixing of tail lamps
CC	Structures and mechanical parts, Sources of fatigue loading
DD	Assessment of Maintenance Arrangements

**▼B**

Reference	Title
EE	Structures and mechanical parts, Footsteps and handrails
FF	Braking, List of approved brake components
GG	Specific Cases, Irish loading gauges
HH	Specific Cases, Republic of Ireland and Northern Ireland Interface between vehicles
II	Assessment Procedure: Limits for modifications of freight wagons not requiring new approval
JJ	
KK	Infrastructure and Rolling Stock Register: Infrastructure Register
LL	Hot axle box detection reference document
YY	Structures and mechanical parts, Strength requirements for certain types of wagon components
ZZ	Structures and mechanical parts, Permissible Stress Based on Elongation Criteria





## TRANS-EUROPEAN CONVENTIONAL RAIL SYSTEM

### Technical Specification for Interoperability Subsystem Rolling Stock Scope Freight Wagons

#### 1. INTRODUCTION

##### 1.1. TECHNICAL SCOPE

This TSI concerns the rolling stock subsystem as listed in point 1 of Annex II to Directive 2001/16/EC.

Further information on the rolling stock subsystem is provided in Section 2.

This TSI covers freight wagons only.

##### 1.2. GEOGRAPHICAL SCOPE

The geographical scope of this TSI is the trans-European conventional rail system as described in Annex I to Directive 2001/16/EEC.

##### 1.3. CONTENT OF THIS TSI

In accordance with Article 5(3) of Directive 2001/16/EC, this TSI:

- (a) indicates its intended scope (part of the network or rolling stock referred to in Annex I to the Directive; subsystem or part of subsystem referred to in Annex II to the Directive) — Section 2;
- (b) lays down essential requirements for each subsystem concerned and its interfaces vis-à-vis other subsystems — Section 3;
- (c) establishes the functional and technical specifications to be met by the subsystem and its interfaces vis-à-vis other subsystems. If necessary, these specifications may vary according to the use of the subsystem, for example according to the categories of line, hub and/or rolling stock provided for in Annex I to the Directive — Section 4;
- (d) determines the interoperability constituents and interfaces covered by European specifications, including European standards, which are necessary to achieve interoperability within the trans-European conventional rail system — Section 5;
- (e) states, in each case under consideration, the procedures for the assessment of conformity or suitability for use. This includes in particular the modules defined in Decision 93/465/EEC or, where appropriate, the specific procedures to be used to assess either the conformity or the suitability for use of interoperability constituents and 'EC' verification of subsystems — Section 6;
- (f) indicates the strategy for implementing the TSI. In particular, it is necessary to specify the stages to be completed in order to make a gradual transition from the existing situation to the final situation in which compliance with the TSI shall be the norm — Section 7;
- (g) indicates, for the staff concerned, the professional qualifications and health and safety conditions at work required for the operation and maintenance of the subsystem concerned, as well as for the implementation of the TSI — Section 4.

Moreover, in accordance with Article 5(5), provision may be made for specific cases for each TSI; these are indicated in Section 7.

**▼ B**

Lastly, this TSI also comprises, in Section 4, the operating and maintenance rules specific to the scope indicated in paragraphs 1.1 and 1.2 above.

## 2. DEFINITION OF SUBSYSTEM/SCOPE

### 2.1. DEFINITION OF SUBSYSTEM

The rolling stock, which is the subject of this TSI, comprises the freight wagons likely to travel on all or part of the trans-European conventional rail network. The freight wagons include rolling stock designed to carry lorries.

This TSI applies to new, upgraded or renewed freight wagons placed in service after entering this TSI into force.

This TSI does not apply to wagons being subject to a contract already signed before the date of entry into force of this TSI.

The section 7.3., 7.4 and 7.5 describe in which conditions and with which exceptions the TSI requirements shall be met.

The rolling stock freight wagons subsystem includes the structure of the vehicles, braking equipment, coupling and running gear (bogies, axles etc.) suspension, doors and communication systems.

The procedures for maintenance work allowing the mandatory corrective and preventive maintenance to assure safe operation and the performance required are also included in this TSI. They are specified in Section 4.2.8.

Requirements relating to the noise generated by freight wagons are excluded from this TSI, except maintenance issue, as there is a separate TSI dealing with the noise generated by freight wagons, locomotives, multiple units and coaches.

### 2.2. FUNCTIONS OF SUBSYSTEM

The freight wagons shall contribute to the following functions:

‘Load freight’ — the freight wagons provide the means to operate and carry the load safely.

‘Move rolling stock’ — the freight wagons are able to be moved safely on the network and contribute to the braking of the train.

‘Maintain and provide data on rolling stock, infrastructure and timetable’ — Specification of the maintenance file and certification of the maintenance establishments allow the control of the freight wagon maintenance. Data relating to the freight wagons is provided in the rolling stock register, marked on the wagons, and eventually by means of vehicle to vehicle and vehicle to ground communication devices.

‘Operate a train’ — the freight wagon shall be able to be operated safely under all expected environmental conditions and in certain expected situations.

‘Provide services for freight customers’ — Data relating to the freight wagon to support freight services for customers is provided in the rolling stock register, marked on the wagons and eventually by means of vehicle to ground communication devices.

### 2.3. INTERFACES OF SUBSYSTEM

The rolling stock freight wagons subsystem experiences the following interfaces to:

#### **Control and command and signalling subsystem -**

— Rolling stock parameters which influence ground based train monitoring systems

— Hot axle bearing detectors

— Electrical detection of the wheelset

**▼B**

- Axle counters
- Braking performance

**Traffic operation and management subsystem**

- Interface between vehicles, between sets of vehicles and between trains
- Doors closing and locking
- Securing of freight
- Loading rules
- Dangerous goods
- Longitudinal compressive forces
- Braking performance
- Aerodynamic effects
- Maintenance

**Telematics applications for freight service subsystem**

- Rolling stock reference data bases
- Wagon and intermodal unit operational database

**Infrastructure subsystem**

- Interface between vehicles, between sets of vehicles and between trains
- Buffers
- Kinematic gauge
- Static axle load, dynamic wheel load and linear load
- Vehicle dynamic behaviour
- Braking performance
- Fire protection

**Energy subsystem**

- Electrical protection

**Noise Aspect**

- Maintenance

**The Council Directive 96/49/EC and its Annex (RID).**

- Dangerous goods

**3. ESSENTIAL REQUIREMENTS****3.1. GENERAL**

In the scope of the present TSI compliance with the specifications described:

- in section 4 for the subsystem
  - and in section 5 for the interoperability constituents,
- as demonstrated by a positive result of the assessment of:
- conformity and/or suitability for use of the interoperability constituents,
  - and of verification of the subsystem, as described in section 6.

ensures fulfilment of the relevant essential requirements quoted in section 3 of this TSI.

Nevertheless, if part of the essential requirements are covered by national rules because of:

**▼ B**

- open and reserved points declared in the TSI,
- derogation under article 7 of the Directive 2001/16/EC,
- specific cases described in section 7.7 of the present TSI,

the corresponding conformity assessment shall be carried out according to procedures under the responsibility of the Member State concerned.

Under Article 4(1) of Directive 2001/16/EC, the trans-European conventional rail system, subsystems and interoperability constituents including interfaces shall meet the relevant essential requirements set out in Annex III to the Directive 2001/16/EC.

### 3.2. *THE ESSENTIAL REQUIREMENTS RELATE TO:*

- Safety
- Reliability and availability
- Health
- Environmental protection
- Technical compatibility.

These requirements include general requirements, and requirements specific to each subsystem.

### 3.3. *GENERAL REQUIREMENTS*

#### 3.3.1. SAFETY

*Essential Requirement 1.1.1 of Annex III to Directive 2001/16/EC.*

The design, construction or assembly, maintenance and monitoring of safety-critical components and, more particularly, of the components involved in train movements must be such as to guarantee safety at the level corresponding to the aims laid down for the network, including those for specific degraded situations.

This essential requirement is satisfied by the functional and technical specifications in sections:

- 4.2.2.1 (interface between vehicles)
- 4.2.2.2 (safe access and egress)
- 4.2.2.3 (strength of main vehicle structure)
- 4.2.2.5 (marking of freight wagons)
- 4.2.3.4 (vehicle dynamic behaviour)
- 4.2.3.5 (longitudinal compressive forces)
- 4.2.4 (braking)
- 4.2.6 (environmental conditions)
- 4.2.7 (system protection), except 4.2.7.3 (electrical protection)
- 4.2.8 (maintenance)

*Essential Requirement 1.1.2:*

The parameters involved in the wheel/rail contact must meet the stability requirements needed in order to guarantee safe movement at the maximum authorised speed.

This essential requirement is satisfied by the functional and technical specifications in sections:

- 4.2.3.2 (axle and wheel loading)
- 4.2.3.4 (vehicle dynamic behaviour)
- 4.2.3.5 (longitudinal compressive forces)

**▼B**

*Essential requirement 1.1.3 of Annex III to Directive 2001/16/EC.*

The components used must withstand any normal or exceptional stresses that have been specified during their period in service. The safety repercussions of any accidental failures must be limited by appropriate means.

This essential requirement is satisfied by the functional and technical specifications in sections:

- 4.2.2.1 (interface between vehicles)
- 4.2.2.2 (safe access and egress for rolling stock)
- 4.2.2.3 (strength of main vehicle structure)
- 4.2.2.4 (doors closing)
- 4.2.2.6 (dangerous goods)
- 4.2.3.3.2 (hot axle box detection)
- 4.2.4 (braking)
- 4.2.6 (environmental conditions)
- 4.2.8 (maintenance)

*Essential Requirement 1.1.4 of Annex III to Directive 2001/16/EC.*

The design of fixed installations and rolling stock and the choice of the materials used must be aimed at limiting the generation, propagation and effects of fire and smoke in the event of a fire.

This essential requirement is satisfied by the functional and technical specifications in sections

- 4.2.7.2 (fire safety)

*Essential Requirement 1.1.5 of Annex III to Directive 2001/16/EC.*

Any devices intended to be handled by users must be so designed as not to impair the safe operation of the devices or the health and safety of users if used foreseeably in a manner not in accordance with the posted instructions.

This essential requirement is satisfied by the functional and technical specifications in sections:

- 4.2.2.1 (interface between vehicles)
- 4.2.2.2 (safe access and egress for rolling stock)
- 4.2.2.4 (doors closing)
- 4.2.4 (braking)

### 3.3.2. RELIABILITY AND AVAILABILITY

*Essential Requirement 1.2 of Annex III to Directive 2001/16/EC.*

The monitoring and maintenance of fixed or movable components that are involved in train movements must be organised, carried out and quantified in such a manner as to maintain their operation under the intended conditions.

This essential requirement is satisfied by the functional and technical specifications in sections:

- 4.2.2.1 (interface between vehicles)
- 4.2.2.2 (safe access and egress for rolling stock)
- 4.2.2.3 (strength of main vehicle structure)
- 4.2.2.4 (doors closing)
- 4.2.2.5 (wagon markings)
- 4.2.2.6 (dangerous goods)
- 4.2.4.1 (braking system)
- 4.2.7.2.2.5 (maintenance of the fire protection measures)

**▼B**

— 4.2.8 (maintenance)

## 3.3.3. HEALTH

*Essential Requirement 1.3.1 of Annex III to Directive 2001/16/EC.*

Materials likely, by virtue of the way they are used, to constitute a health hazard to those having access to them must not be used in trains and railway infrastructure.

This essential requirement is satisfied by the functional and technical specifications in sections:

— 4.2.8 (maintenance)

*Essential Requirement 1.3.2 of Annex III to Directive 2001/16/EC.:*

Those materials must be selected, deployed and used in such a way as to restrict the emission of harmful and dangerous fumes or gases, particularly in the event of fire.

This essential requirement is satisfied by the functional and technical specifications in sections:

— 4.2.7.2 (fire safety)

— 4.2.8 (maintenance)

## 3.3.4. ENVIRONMENTAL PROTECTION

*Essential Requirement 1.4.1 of Annex III to Directive 2001/16/EC.*

The environmental impact of establishment and operation of the trans-European conventional rail system must be assessed and taken into account at the design stage of the system in accordance with the Community provisions in force.

This essential requirement is not relevant within the scope of this TSI.

*Essential Requirement 1.4.2 of Annex III to Directive 2001/16/EC.*

The materials used in the trains and infrastructure must prevent the emission of fumes or gases which are harmful and dangerous to the environment, particularly in the event of fire.

This essential requirement is satisfied by the functional and technical specifications in sections:

— 4.2.7.2 (fire safety)

— 4.2.8 (maintenance)

*Essential Requirement 1.4.3 of Annex III to Directive 2001/16/EC.*

The rolling stock and energy-supply systems must be designed and manufactured in such a way as to be electromagnetically compatible with the installations, equipment and public or private networks with which they might interfere.

This essential requirement is satisfied by the functional and technical specifications in sections:

— 4.2.3.3 (communication between vehicle and ground)

*Essential Requirement 1.4.4 of Annex III to Directive 2001/16/EC.*

Operation of the trans-European conventional rail system must respect existing regulations on noise pollution.

This essential requirement is satisfied by the functional and technical specifications in sections:

— 4.2.8 (maintenance)

— 4.2.3.4 (vehicle dynamic behaviour)

**▼B**

*Essential Requirement 1.4.5 of Annex III to Directive 2001/16/EC.:*

Operation of the trans-European conventional rail system must not give rise to an inadmissible level of ground vibrations for the activities and areas close to the infrastructure and in a normal state of maintenance.

This essential requirement is satisfied by the functional and technical specifications in sections:

- 4.2.3.2 (static axle load, dynamic wheel load and linear load)
- 4.2.3.4 (vehicle dynamic behaviour)
- 4.2.8 (maintenance)

### 3.3.5. TECHNICAL COMPATIBILITY

*Essential Requirement 1.5 of Annex III to Directive 2001/16/EC.*

*The technical characteristics of the infrastructure and fixed installations must be compatible with each other and with those of the trains to be used on the trans-European conventional rail system.*

If compliance with these characteristics proves difficult on certain sections of the network, temporary solutions, which ensure compatibility in the future, may be implemented.

This essential requirement is satisfied by the functional and technical specifications in sections:

- 4.2.3.1 (kinematic gauge)
- 4.2.3.2 (static axle load, dynamic wheel load and linear load)
- 4.2.3.4 (vehicle dynamic behaviour)
- 4.2.3.5 (longitudinal compressive forces)
- 4.2.4 (braking)
- 4.2.8 (maintenance)

## 3.4. REQUIREMENTS SPECIFIC TO THE ROLLING STOCK SUBSYSTEM

### 3.4.1. SAFETY

*Essential Requirement 2.4.1 of Annex III to Directive 2001/16/EC.*

The structure of the rolling stock and of the links between vehicles must be designed in such a way as to protect the passenger and driving compartments in the event of collision or derailment.

This essential requirement is not relevant within the scope of this TSI.

The electrical equipment must not impair the safety and functioning of the control and command and signalling installations.

This essential requirement is not relevant within the scope of this TSI.

The braking techniques and the stresses exerted must be compatible with the design of the track, engineering structures and signalling systems.

This essential requirement is satisfied by the functional and technical specifications in sections:

- 4.2.3.5 (longitudinal compressive forces)
- 4.2.4 (braking)

Steps must be taken to prevent access to electrically-live constituents in order not to endanger the safety of persons.

This essential requirement is satisfied by the functional and technical specifications in sections:

**▼B**

- 4.2.2.5 (marking of freight wagons)
- 4.2.7.3 (electrical protection)
- 4.2.8 (maintenance)

In the event of danger, devices must enable passengers to inform the driver and accompanying staff to contact him.

This essential requirement is not relevant within the scope of this TSI.

The access doors must incorporate an opening and closing system, which guarantees passenger safety.

This essential requirement is not relevant within the scope of this TSI.

Emergency exits must be provided and indicated.

This essential requirement is not relevant within the scope of this TSI.

Appropriate provisions must be laid down to take account of the particular safety conditions in very long tunnels.

This essential requirement is not relevant within the scope of this TSI.

An emergency lighting system of sufficient intensity and duration is compulsory on board trains.

This essential requirement is not relevant within the scope of this TSI.

Trains must be equipped with a public address system which provides a means of communication to the public from on-board staff and ground control.

This essential requirement is not relevant within the scope of this TSI.

### 3.4.2. RELIABILITY AND AVAILABILITY

*Essential Requirement 2.4.2 of Annex III to Directive 2001/16/EC.*

The design of the vital equipment, of the running, traction and braking equipment and of the control and command system must be such as to enable the train to continue its mission, in a specific degraded situation, without adverse consequences for the equipment remaining in service.

This essential requirement is satisfied by the functional and technical specifications in sections:

- 4.2.4.1.2.6 (wheel-slide-protection, see also section 5.3.3.3 and Annex I)
- 5.4.1.2 (Draw gear)
- 5.4.2.1 (Bogie and running gear)
- 5.4.2.2 (wheelsets)
- 5.4.3.8 (Isolating device for distributor)

### 3.4.3. TECHNICAL COMPATIBILITY

*Essential Requirement 2.4.3 of Annex III to Directive 2001/16/EC.:*

The electrical equipment must be compatible with the operation of the control and command and signalling installations.

This essential requirement is not relevant within in the scope of this TSI.

In the case of electric traction, the characteristics of the current-collection devices must be such as to enable trains to



**▼B**

travel under the energy-supply systems for the trans-European conventional rail system.

This essential requirement is not relevant within the scope of this TSI.

The characteristics of the rolling stock must be such as to allow it to travel on any line on which it is expected to operate.

This essential requirement is satisfied by the functional and technical specifications in sections:

- 4.2.2.3 (strength of main vehicle structure)
- 4.2.3.1 (kinematic gauge)
- 4.2.3.2 (static axle load, dynamic wheel load and linear load)
- 4.2.3.3 (rolling stock parameters which influence ground based train monitoring -systems)
- 4.2.3.4 (vehicle dynamic behaviour)
- 4.2.3.5 (longitudinal compressive forces)
- 4.2.4 (braking)
- 4.2.6 (environmental conditions)
- 4.2.8 (maintenance)
- 4.8.2 (rolling stock register)

### 3.5. *REQUIREMENTS SPECIFIC TO MAINTENANCE*

#### 3.5.1. HEALTH AND SAFETY

*Essential Requirement 2.5.1 of Annex III to Directive 2001/16/EC.*

The technical installations and the procedures used in the centres must ensure the safe operation of the subsystem and not constitute a danger to health and safety.

This essential requirement is satisfied by the functional and technical specifications in sections:

- 4.2.8 (maintenance)

#### 3.5.2. ENVIRONMENTAL PROTECTION

*Essential Requirement 2.5.2 of Annex III to Directive 2001/16/EC.*

The technical installations and the procedures used in the maintenance centres must not exceed the permissible levels of nuisance with regard to the surrounding environment.

This essential requirement is not satisfied by the functional and technical specifications within the scope of this TSI.

#### 3.5.3. TECHNICAL COMPATIBILITY

*Essential Requirement 2.5.3 of Annex III to Directive 2001/16/EC.*

The maintenance installations for conventional rolling stock must be such as to enable safety, health and comfort operations to be carried out on all stock for which they have been designed.

This essential requirement is satisfied by the functional and technical specifications in sections:

- 4.2.8 (maintenance)

**▼ B**3.6. *REQUIREMENTS SPECIFIC TO OTHER SUBSYSTEMS CONCERNING ALSO THE ROLLING STOCK SUBSYSTEM*

## 3.6.1. INFRASTRUCTURE SUBSYSTEM

3.6.1.1. **Safety**

*Essential Requirement 2.1.1 of Annex III to Directive 2001/16/EC.:*

Appropriate steps must be taken to prevent access to or undesirable intrusions into installations.

Steps must be taken to limit the dangers to which persons are exposed, particularly when trains pass through stations.

Infrastructure to which the public has access must be designed and made in such a way as to limit any human safety hazards (stability, fire, access, evacuation, platforms, etc.).

Appropriate provisions must be laid down to take account of the particular safety conditions in very long tunnels.

This essential requirement is not relevant within the scope of this TSI.

## 3.6.2. ENERGY SUBSYSTEM

3.6.2.1. **Safety**

*Essential Requirement 2.2.1 of Annex III to Directive 2001/16/EC.*

Operation of the energy-supply systems must not impair the safety either of trains or of persons (users, operating staff, trackside dwellers and third parties).

This essential requirement is not relevant within the scope of this TSI.

3.6.2.2. **Environmental protection**

*Essential Requirement 2.2.2 of Annex III to Directive 2001/16/EC.*

The functioning of the electrical or thermal energy-supply systems must not interfere with the environment beyond the specified limits.

This essential requirement is not relevant within the scope of this TSI.

3.6.2.3. **Technical compatibility**

*Essential Requirement 2.2.3 of Annex III to Directive 2001/16/EC.*

The electricity/thermal energy supply systems used must:

- enable trains to achieve the specified performance levels;
- in the case of electricity energy supply systems, be compatible with the collection devices fitted to the trains.

This essential requirement is not relevant within the scope of this TSI.

## 3.6.3. CONTROL AND COMMAND AND SIGNALLING

3.6.3.1. **Safety**

*Essential Requirement 2.3.1 of Annex III to Directive 2001/16/EC.:*

The control and command and signalling installations and procedures used must enable trains to travel with a level of safety which corresponds to the objectives set for the network. The control and command and signalling systems should continue to provide for safe passage of trains permitted to run under degraded conditions.

**▼ B**

This essential requirement is not relevant within the scope of this TSI.

3.6.3.2. **Technical compatibility**

*Essential Requirement 2.3.2 of Annex III to Directive 2001/16/EC.*

All new infrastructure and all new rolling stock manufactured or developed after adoption of compatible control and command and signalling systems must be tailored to use of those systems. The control and command and signalling equipment installed in the train drivers' cabs must permit normal operation, under the specified conditions, throughout the trans-European conventional rail system.

This essential requirement is satisfied by the functional and technical specifications in sections:

- 4.2.3.3.1 (electrical resistance)
- 4.2.4 (braking)

3.6.4. OPERATION AND TRAFFIC MANAGEMENT

3.6.4.1. **Safety**

*Essential Requirement 2.6.1 of Annex III to Directive 2001/16/EC.*

Alignment of the network operating rules and the qualifications of drivers and on-board staff and of the staff in the control centres must be such as to ensure safe operation, bearing in mind the different requirements of cross-border and domestic services.

The maintenance operations and intervals, the training and qualifications of the maintenance and control centre staff and the quality assurance system set up by the operators concerned in the control and maintenance centres must be such as to ensure a high level of safety.

This essential requirement is satisfied by the functional and technical specifications in sections:

- 4.2.2.5 (marking of freight wagons)
- 4.2.4 (braking)
- 4.2.8 (maintenance)

3.6.4.2. **Reliability and availability**

*Essential Requirement 2.6.2. of Annex III to Directive 2001/16/EC.*

The maintenance operations and periods, the training and qualifications of the maintenance and control centre staff and the quality assurance system set up by the operators concerned in the control and maintenance centres must be such as to ensure a high level of system reliability and availability.

This essential requirement is satisfied by the functional and technical specifications in sections:

- 4.2.8 (maintenance)

3.6.4.3. **Technical compatibility**

*Essential Requirement 2.6.3 of Annex III to Directive 2001/16/EC.*

Alignment of the network operating rules and the qualifications of drivers, on-board staff and traffic managers must be such as to ensure operating efficiency on the trans-European conventional rail system, bearing in mind the different requirements of cross-border and domestic services.

This essential requirement is not relevant within the scope of this TSI.

**▼ B**

## 3.6.5. TELEMATICS APPLICATIONS FOR FREIGHT AND PASSENGERS

3.6.5.1. **Technical compatibility**

*Essential Requirement 2.7.1 of Annex III to Directive 2001/16/EC.*

The essential requirements for Telematics applications guarantee a minimum quality of service for passengers and carriers of goods, particularly in terms of technical compatibility.

Steps must be taken to ensure:

- that the databases, software and data communication protocols are developed in a manner allowing maximum data interchange between different applications and operators, excluding confidential commercial data;
- easy access to the information for users.

This essential requirement is not relevant within the scope of this TSI.

3.6.5.2. **Reliability and availability**

*Essential Requirement 2.7.2 of Annex III to Directive 2001/16/EC.*

The methods of use, management, updating and maintenance of these databases, software and data communication protocols must guarantee the efficiency of these systems and the quality of the service.

This essential requirement is not relevant within the scope of this TSI.

3.6.5.3. **Health**

*Essential Requirement 2.7.3:*

The interfaces between these systems and users must comply with the minimum rules on ergonomics and health protection.

This essential requirement is not relevant within the scope of this TSI.

3.6.5.4. **Safety**

*Essential Requirement 2.7.4 of Annex III to Directive 2001/16/EC.*

Suitable levels of integrity and dependability must be provided for the storage or transmission of safety-related information.

This essential requirement is not relevant within the scope of this TSI.

4. **CHARACTERISATION OF THE SUBSYSTEM**4.1. **INTRODUCTION**

The trans-European conventional rail system, to which Directive 2001/16/EC applies and of which the rolling stock freight wagons subsystem is a part, is an integrated system whose compatibility shall be verified. This compatibility shall be checked in particular with regard to the specifications of the subsystem, its interfaces vis-à-vis the system in which it is integrated, as well as the operating and maintenance rules.

The functional and technical specifications of the subsystem and its interfaces, described in sections 4.2 and 4.3, do not impose the use of specific technologies or technical solutions, except where this is strictly necessary for the interoperability of the trans-European conventional rail network. But innovative solutions for interoperability may require new specifications and/or new assessment methods. In order to allow technological innovation, these specifications and assessment methods shall be developed by the process described in sections 6.1.2.3 and 6.2.2.2.

**▼ B**

Taking account of all the applicable essential requirements, the rolling stock freight wagons subsystem is characterised in the present section 4.

#### 4.2. *FUNCTIONAL AND TECHNICAL SPECIFICATIONS OF THE SUBSYSTEM*

##### 4.2.1. GENERAL

In light of the essential requirements in Section 3, the functional and technical specifications of the rolling stock freight wagons subsystem are arranged as follows:

- Structures and mechanical parts
- Vehicle track interaction and gauging
- Braking
- Communication
- Environmental conditions
- System protection
- Maintenance

These headings include the basic parameters as follows:

##### *Structures and mechanical parts*

Interface (e. g. Coupling) between vehicles, between set of Vehicles and between trains

Safe access and egress for rolling stock

Strength of main vehicle structure

Securing of Freight

Doors closing and locking

Marking of freight wagons

Dangerous goods

##### *Vehicle track interaction and gauging*

Kinematic gauge

Static axle load, dynamic wheel load and linear load

Rolling stock parameters which influence ground based train monitoring systems

Vehicle dynamic behaviour

Longitudinal compressive forces

##### *Braking*

Braking performance

##### *Communication*

Vehicle capability to transmit information from vehicle to vehicle

Vehicle capability to transmit information between ground and vehicle

##### *Environmental conditions*

Environmental conditions

Aerodynamic effects

Cross winds

##### *System protection*

Emergency Measures

Fire safety

**▼ B**

Electrical protection

*Maintenance*

Maintenance file

For each basic parameter a General paragraph introduces the following paragraphs.

These following paragraphs detail the conditions to be met in order to fulfil the requirements introduced in the General paragraph.

4.2.2. STRUCTURES AND MECHANICAL PARTS:

4.2.2.1. ***Interface (e. g. Coupling) between vehicles, between set of vehicles and between trains***

4.2.2.1.1. **General**

Wagons shall have resilient buffing and draw gear at both ends.

Rakes of wagons, which are always operated as a unit when in service are considered to be a single wagon for the application of this requirement. The interfaces between these wagons shall incorporate a resilient coupling system, which is capable of withstanding the forces due to the intended operational conditions.

Trains, which are always operated as a unit in service, are considered to be a single wagon for the application of this requirement. They also shall incorporate a resilient coupling system as above. If they do not have a standard screw coupler and buffers they shall have the facility to fit an emergency coupler at both ends.

4.2.2.1.2. **Functional and technical specifications**

4.2.2.1.2.1. *Buffers*

When buffers are fitted, two identical buffers shall be fitted at a wagon end. These buffers shall be of a compressible type. The height of the centre line of the buffing gear shall be between 940 mm and 1 065 mm above rail level in all conditions of loading.

The standard distance between buffer centrelines shall be nominally 1 750 mm symmetrically about the centreline of the freight wagon.

Buffers shall be sized so that in horizontal curves and reverse curves, it is not possible for vehicles to lock buffers. The minimum acceptable overlap shall be 50mm.

The Infrastructure TSI specifies the minimum curve radius and reverse curve characteristics.

Wagons fitted with buffers with a stroke in excess of 105 mm shall be fitted with four identical buffers (elastic systems, stroke) exhibiting the same design characteristics.

If interchangeability of the buffers is required a free space on the headstock shall be provided for the supporting plate. The buffer shall be fixed to the wagon headstock by means of four M24 locked fasteners of a quality class which provides a yield strength of at least 640 N/mm<sup>2</sup> (see Annex A fig. A1).

— Buffer characteristics

Buffers shall have a minimum stroke of 105 mm<sup>0\_5</sup> mm and a dynamic energy absorption capacity of at least 30 kJ.

The buffer heads shall be convex with a radius of curvature of their spherical working surface of 2 750 mm ± 50 mm.

Minimum height of the buffer head shall be 340 mm equally spaced from the longitudinal buffer axis.

**▼B**

Buffers shall have an identification mark. The identification mark shall contain at least the buffer stroke in 'mm' and a value for the energy absorption capacity of the buffer.

4.2.2.1.2.2. *Draw Gear*

The standard draw gear between vehicles shall be non-continuous and comprises a screw coupling permanently attached to the hook, a draw hook and a draw bar with an elastic system

The height of the centre line of the draw hook shall be between 920 mm and 1 045 mm above rail level in all conditions of loading.

Each wagon end shall have a facility for supporting a coupling when it is not in use. No part of the coupler assembly shall reach below 140 mm above rail level when at its lowest position due to wear and suspension travel.

— Draw gear characteristics:

The elastic system of the draw gear shall have as a minimum a static capacity of absorption of 8 kJ.

The draw hook and the draw bar shall withstand a force of 1 000 kN without breaking.

The screw coupler shall withstand a force of 850 kN without breaking. The breaking strength of the screw coupler shall be lower than the breaking strength of other parts of the draw gear.

The screw coupler shall be designed such that in-train forces cannot cause the coupler to unscrew involuntarily.

The maximum weight of the screw coupler shall not exceed 36 kg.

The dimensions of the screw couplers and draw hooks see Annex A fig A6 shall be as shown in Annex A figures A2 and A3. The coupler length measured from the inside face of the coupler bow to the draw-bar pin centre-line shall be:

- 986 mm <sup>+10</sup><sub>-5</sub> mm with completely screwed-out coupler
- 750 mm <sup>± 10</sup> mm with completely screwed-in coupler

4.2.2.1.2.3. *Interaction of draw- and buffing-gear*

The characteristics of the buffers and draw gear shall be designed in order to enable the safe transit of curves in the track with a radius of 150 m.

Two wagons with bogies coupled on straight track with touching buffers shall generate compressive forces no higher than 250 kN on a 150 m radius curve.

There is no requirement specified for two axle wagons.

— Draw gear and buffing gear characteristics

The distance between the front edge of a draw-hook opening and the front side of the fully extended buffers shall be 355 mm + 45/-20 mm in the new condition as shown in Annex A fig. A4.

4.2.2.2. *Safe access and egress for rolling stock*

Vehicles shall be designed so that staff are not exposed to undue risk during coupling and uncoupling. If screw couplers and side buffers are used, the required spaces shown in Annex A fig. A5 shall be free of fixed parts. Connecting cables and flexible hoses may be inside this space. There shall be no devices under the buffers that hinder the access to the space.

The clearance above the draw hook is viewed in Annex A fig. A7.

If a combined automatic and screw coupler is fitted it is permissible for the auto coupler head to infringe the Berne

**▼B**

rectangle on the left hand side (as viewed Annex A fig. A5) when it is stowed and the screw coupler is in use.

There shall be a handrail under each buffer. The handrails shall withstand the loads, which are applied by the shunters while accessing the space between the buffers.

At the ends of a wagon there shall be no fixed parts within 40 mm of a vertical plane placed at the end of the fully compressed buffers.

Except for wagons used only in fixed formation trains, there shall be at least one step and one handrail for shunters at each side of the vehicle. There shall be sufficient space above and around the steps that the safety of the shunter is ensured. Steps and handrails shall be designed to withstand the loads that are applied by the shunter. Steps shall be at least 150 mm from a vertical plane at the end of the fully compressed buffers (see Annex A figure A5). Steps and areas, which provide access for operation, loading and unloading, shall be slip resistant (see Annex EE).

At each end of a wagon that may form the end of a train, there shall be devices for mounting a taillight. Steps and handrails shall be provided where necessary to enable easy access.

The handrails and footsteps shall be inspected at normal maintenance periods and remedial action taken if signs of significant damage, cracking or corrosion are found.

#### 4.2.2.3. ***Strength of Main Vehicle Structure and Securing of Freight***

##### 4.2.2.3.1. **General**

The structural design of wagon shall be carried out in accordance with the requirements of Section 3 of EN12663 and the structure shall meet the criteria defined in Clauses 3.4 to 3.6 of this standard.

In addition to the criteria already identified, it is permissible to take the material elongation at failure into account in the selection of the safety factor defined in clause 3.4.3 of EN12663. Annex ZZ defines how the safety factor and permissible stress shall be determined.

When performing fatigue life assessments it is important to ensure that the load cases are representative of the intended application and expressed in a manner consistent with the adopted design code. Any relevant guidelines on the interpretation of the selected design code shall be followed.

The permissible stresses for the materials used in the construction of wagons shall be determined as specified in Section 5 of EN12663.

The wagon structure shall be inspected at normal maintenance periods and remedial action taken if signs of significant damage, cracking or corrosion are found.

This section defines the minimum structural requirements for the main load carrying (primary) structure of the wagons and the interfaces with equipment and payload.

These requirements cover:

- Exceptional loads:
  - Longitudinal design loads
  - Maximum vertical load
  - Load combinations
  - Lifting and jacking
  - Equipment attachment (including body/bogie)
  - Other exceptional loads



**▼ B**

- Service (fatigue) loads:
  - Sources of load input
  - Payload spectrum
  - Track induced loading
  - Traction and braking
  - Aerodynamic loading
  - Fatigue loads at interfaces
  - Body/bogie connection
  - Equipment attachment
  - Coupler loads
  - Combinations of fatigue loads
- Stiffness of the main vehicle structure
  - Deflection
  - Mode of vibration
  - Torsional stiffness
  - Equipment
- Securing of freight

Measures shall be taken to ensure that the load or parts of the load do not leave the freight wagon accidentally.

Requirements for fastening systems or devices such as spigots or securing rings are not mandatory in this TSI

#### 4.2.2.3.2. **Exceptional Loads**

##### 4.2.2.3.2.1. *Longitudinal Design Loads*

Different values will apply for different kinds of freight wagons as identified in EN12663 namely:

F-I: Wagons that may be shunted without restriction;

F-II: Wagons excluded from hump or loose shunting.

The basic structural design requirements assume that wagons in the above categories are fitted with buffers and couplers appropriate to the operations.

The structure shall conform to the requirements of Clause 3.4 of EN12663 when subject to all exceptional load cases.

The wagon bodies shall meet the longitudinal strength requirements as specified in tables 1, 2, 3, and 4 of EN12663 as appropriate, where the load paths exist.

NOTE 1: A force applied to one end of the wagon body shall be reacted at the corresponding position at the opposite end.

NOTE 2: Forces shall be applied horizontally to the mounting structure, divided equally on the axis of each side buffer location or on the axis of the coupler.

NOTE 3: If a buffing test (see Annex Z) is not to be performed, calculations shall be used to demonstrate that the wagon structure is capable of sustaining the maximum buffing loads it is expected to experience in service.

##### 4.2.2.3.2.2. *Maximum Vertical Load*

The wagon body shall meet the requirements of table 8 of EN12663 modified as indicated in Note 1 below.

The wagon body shall also be designed to carry the anticipated maximum loads due to the method of loading and unloading. It is

**▼ B**

permissible to define the load cases either in terms of forces or in terms of accelerations applied to the mass being added and to the mass of the body plus any existing payload. The design cases shall represent the most unfavourable cases that the operator wishes to consider associated with the use of the wagon (including foreseeable abuse).

NOTE 1: The factor of 1,3 shall be used instead of 1,95 quoted in table 8 of EN 12663 and note 'a' shall not apply.

NOTE 2: Loads may be distributed uniformly over the full load-carrying surface, over a limited area or at discrete positions. The design case(s) shall be based on the most demanding applications.

NOTE 3: If it is intended that wheeled vehicles (including fork-lift trucks etc.) will operate over the floor of the wagon then the design shall accommodate the maximum local pressure loading associated with such operations.

#### 4.2.2.3.2.3. *Load combinations*

The structure shall also conform to the requirements of Clause 3.4 of EN12663 when subject to the most adverse load combinations as specified in Clause 4.4 of EN12663.

#### 4.2.2.3.2.4. *Lifting and Jacking*

The wagon body shall incorporate lifting points by which the whole wagon is capable of being safely lifted or jacked. It shall also be possible to lift one end of the wagon (including its running gear) with the other end resting on the remaining running gear.

The load cases specified in Clause 4.3.2 of EN12663 shall apply for lifting and jacking under workshop and servicing operations.

For lifting cases associated only with rescue following derailment or other abnormal incident, where some permanent deformation of the structure is acceptable, it is permissible to reduce the load factor in Tables 9 and 10 from 1,1 to 1,0.

If a factor of 1,0 is used for a validation test, the measured strains shall be extrapolated to demonstrate the conformance to the higher factor.

The lifting shall occur via designated lifting points. The location of the lifting points shall be defined by the customer's operational requirements.

#### 4.2.2.3.2.5. *Equipment Attachment (Including body/bogie)*

The attachments of equipment shall be designed either:

— to carry the loads specified in tables 12, 13 and 14 of Section 4.5 of EN12663

Or as an alternative

— to be validated by carrying out an buffing test as described in Annex Z.

#### 4.2.2.3.2.6. *Other Exceptional Loads*

The load requirements for structural parts of the wagon body, such as side and end wall structures, doors, stanchions and load restraint systems shall be designed to carry the maximum loads they will experience in performing their intended function. The load cases shall be determined using the principles for structural design given in EN12663.

Annex YY provides suitable design requirements for common types of wagon features that are in general use. However they shall be used only where they are applicable.

For new types of wagon the designer shall determine appropriate load cases to meet the specific requirements using the principles given in EN12663.

**▼B****4.2.2.3.3. Service (fatigue) Loads****4.2.2.3.3.1. Sources of load input.**

All sources of cyclic loading that can cause fatigue damage shall be identified. In accordance with Clause 4.6 of EN12663, the inputs listed in Annex N shall be considered and the way in which they are represented and combined shall be consistent with the intended use of the freight wagon. The definition of the load cases shall also be consistent with the material fatigue design code to be used as described in Clause 5.2 and method of validation in Clause 6.3 of EN12663. Where the fatigue load cases act in combination, they shall be taken into account in a manner consistent with the characteristics of the loads and the form of design analysis and fatigue design code being employed.

For most conventional wagon designs the loading defined in Table 16 of EN12663 can be considered as sufficient to represent the full effective combination of fatigue load cycles.

Where detailed data are not available, Annex CC shall be used to determine the main sources of fatigue loading.

**4.2.2.3.3.2. Demonstration of fatigue strength**

In accordance with Clause 5.2 of EN12663, the behaviour of materials under fatigue loading shall be based on current European Standard, or alternative sources of equivalent standing, wherever such sources are available. Acceptable material fatigue design codes are Eurocode 3 and Eurocode 9 as well as the method described in Annex N.

**4.2.2.3.4. Stiffness of the main vehicle structure****4.2.2.3.4.1. Deflections**

Deflections under the loads or load combinations shall not be such as to cause the wagon or its payload to exceed the permitted operational envelope (see Annex C and Annex T).

Deflections shall also not impair the functionality of the wagon as a whole or that of any installed components or systems.

**4.2.2.3.4.2. Modes of vibration**

The design process shall take into account that the natural modes of vibration of the wagon body, in all loading conditions including tare, shall be separated sufficiently, or otherwise de-coupled from the suspension frequencies, so as to avoid the occurrence of undesirable responses at all operating speeds.

**4.2.2.3.4.3. Torsional stiffness**

The torsional stiffness of the wagon body shall be consistent with the suspension characteristics such that the derailment criteria are achieved in all loading conditions including tare.

**4.2.2.3.4.4. Equipment**

The natural modes of vibration of equipment, on its mountings, shall be separated sufficiently, or otherwise de-coupled from the wagon body or suspension frequencies, so as to avoid the occurrence of undesirable responses at all operating speeds.

**4.2.2.3.5. Securing of Freight**

Annex YY provides suitable design requirements for common types of features that are in general use. However they shall be used only where they are applicable.

**4.2.2.4. Doors closing and locking**

Doors and hatches of freight vehicles shall be designed to be closed and locked. This remains valid while the vehicles are in a moving train (unless this is part of the procedure for discharging the payload). For this, locking devices shall be used which indicate their status (open/closed) and they shall be visible by an operator outside the train.

**▼ B**

The locking devices shall be designed to be secured against unintentional opening during running. Closing and locking systems shall be designed so that the operating staff are not placed at undue risk.

Suitable and clear instructions for use shall be applied near each locking device and shall be visible by the operator.

The closing and locking devices shall be designed to withstand the loads which are caused by the payload under normal, regular conditions and when the payload has been displaced in a foreseeable manner.

The closing and locking devices shall be designed to withstand the loads that occur while the vehicles are passing other trains under all conditions, including when in tunnels.

The forces, which are needed to actuate the closing and locking devices, shall be of a magnitude that can be applied by an operator without additional tools. Exceptions are allowable when additional tools are specifically made available or when motor driven systems are used.

The closing and locking systems shall be inspected at normal maintenance periods and remedial action taken if signs of damage or malfunction are found.

#### 4.2.2.5. **Marking of freight wagons**

Markings are required on wagons to:

- Identify each individual wagon by its unique number, as specified in the Traffic Operations and Management TSI, and recorded in the Register.
- Provide information required to produce train consists, including brake mass, length over buffers, tare weight, speed versus load table for different line categories.
- Identify operational restrictions to staff, including geographical limitations, and shunting restrictions.
- Provide pertinent safety information for staff operating wagons or attending in an emergency, including overhead live wire and electrical equipment warning signs, lift/jacking points, vehicle specific safety instructions.

These markings are listed in the Annex B and pictograms are included if required. The markings shall be located as high as practicable on the wagon structure up to a height of 1 600 mm above rail level. Hazard signs shall be located in such a position that they can be seen before the hazard zone is actually reached. The markings of wagons that do not have vertical sides +/- 10 degrees, shall be affixed on special panels.

Markings may be achieved either by painting or by decals.

The requirements for Dangerous Goods Markings are covered by directive 96/49/EC with its valid Annex

When changes to a wagon occur that require changes to the markings, such changes shall be consistent with changes to the data recorded in the Rolling Stock Register.

Markings shall be cleaned/replaced when required to ensure that they remain legible.

#### 4.2.2.6. **Dangerous goods**

##### 4.2.2.6.1. **General**

Wagons carrying dangerous goods shall meet the requirements of this TSI and in addition the requirements of RID.

Further developments in this legal area are led by an international working group (RID-Committee) of representatives from the governments which are members of the COTIF.

**▼B****4.2.2.6.2. Legislation applicable to rolling stock for the transport of dangerous goods**

Rolling Stock	Council Directive 96/49/EC and its Annex in their valid version
Marking and Labelling	Council Directive 96/49/EC and its Annex in their valid version
Buffers	Council Directive 96/49/EC and its Annex in their valid version
Spark protection	Council Directive 96/49/EC and its Annex in their valid version
Use of wagons for the transport of Dangerous Goods in long tunnels	Under examination by working groups mandated by the European Commission (AEIF and RID)

**4.2.2.6.3. Additional legislation applicable to tanks**

Tank	Council Directive 1999/36/EC on transportable pressure equipment (TPED) in its valid version
Tank testing, inspection and marking	EN 12972 Tanks for transport of dangerous goods-testing, inspection and marking of metallic tanks from April 2001

**4.2.2.6.4. Maintenance rules**

The maintenance of tank/freight wagons shall be compliant with the following European Standard and the Council Directive:

— Testing and inspection	EN 12972 Tanks for transport of dangerous goods-testing, inspection and marking of metallic tanks from April 2001
— Maintenance of Tank and its equipment	<b>Council Directive 96/49/EC and its Annex in their valid version</b>
— Mutual agreements on Tank-inspectors	<b>Council Directive 96/49/EC and its Annex in their valid version</b>

**4.2.3. VEHICLE TRACK INTERACTION AND GAUGING****4.2.3.1. Kinematic gauge**

This section defines the maximum outside dimensions of wagons to ensure that they remain within the infrastructure gauge. To achieve this, the maximum possible movement of the wagon is considered; this is called the kinematic envelope.

The kinematic envelope of the rolling stock is defined by means of a reference profile and its associated rules. It is obtained by applying the rules giving reductions in relation to the reference profile, which the various parts of the rolling stock shall meet.

These reductions depend on:

- the geometric characteristics of the rolling stock in question,

**▼B**

- the position of the cross-section in relation to the bogie pivot or to the axles,
- the height of the point considered in relation to the running surface,
- constructional tolerances,
- the maximum wear allowance,
- the elastic characteristics of the suspension.

The study of the maximum construction gauge takes into account both the lateral and vertical movements of the rolling stock, drawn up on the basis of the geometrical and suspension characteristics of the vehicle under various loading conditions.

The construction gauge of rolling stock travelling on a given section of line shall be smaller, by an appropriate safety margin, than the minimum structure gauge of the line in question.

A rolling stock gauge comprises two fundamental elements: a reference profile and the rules for that profile. It allows determination of the maximum dimensions of rolling stock and the position of fixed structures on the line.

In order that a rolling stock gauge is applicable, the following three parts of that gauge shall be specified:

- the reference profile;
- the rules for determining the maximum construction gauge for the wagons;
- the rules for determining the clearances to structures and the track spacing.

Annex C specifies the reference profile and the rules for the maximum construction gauge for wagons.

The associated rules for determining the clearances for installation of structures are covered in the Infrastructure TSI.

All equipment and parts of wagons that give rise to transverse and vertical displacements shall be checked at appropriate maintenance intervals.

In order to keep the wagon inside the kinematic gauge, the maintenance plan shall include provision for inspection of the following items:

- wheel profile and wear,
- bogie frame,
- springs,
- side bearers,
- body structure,
- constructional clearances,
- maximum wear allowance,
- elastic characteristics of the suspension,
- axle guide wear,
- elements that affect the vehicle flexibility coefficient,
- elements that affect the roll centre.
- Devices causing movements affecting the gauge

#### 4.2.3.2. ***Static axle load and linear load***

The axle load and axle spacing of the vehicles defines the vertical quasi-static load input to the track.

The load limits for wagons take into account their geometrical characteristics, weights per axle and weights per linear metre.

**▼B**

They shall be in accordance with the classification of lines or sections of lines, categories A, B1, B2, C2, C3, C4, D2, D3, D4 as defined in the table below.

Axle loads higher than 22,5 tonnes are not specified in this TSI; existing national rules continue to apply to lines capable of accepting these higher axle loads.

Classification	Mass per axle = P						
	A	B	C	D	E	F	G
Mass per unit length = p	16 t	18 t	20 t	22,5 t	25,0 t	27,5 t	30 t
5,0 t/m	A	B1					
6,4 t/m		B2	C2	D2			
7,2 t/m			C3	D3			
8,0 t/m			C4	D4	E4		
8,8 t/m					E5		
10 t/m							

p = Mass per unit length, i.e. the wagon mass plus the mass of the load, divided by the wagon length in metres, measured over the buffers when non-compressed.

P = Mass per axle.

Annex D Table D.1 contains data from which a train made up of wagons with two 2-axle bogies is used in order to determine the category in which a line is classified.

A line or section of line is classified in one of these categories when it is capable of handling an unlimited number of wagons with the weight characteristics shown in the table above.

Classification according to the maximum mass per axle P is expressed in capital letters (A, B, C, D, E, F, G); classification according to the maximum mass per unit length p is expressed in Arabic numerals (1, 2, 3, 4, 5, 6), except for Category A.

The lines thus classified are capable of handling the wagons listed below:

- Two or three-axle wagons, and wagons with 2-axle bogies, where the measurements a and b are equal to or greater than the values shown in Annex D Table D.1, providing P and p do not exceed the values shown in the table above.
- Two 2-axle bogie wagons where the measurements a and b are smaller than the values shown in Annex D Table D.2, providing they have reduced mass per axle, Pr, complying with the values given in Annex D Table D.3 in relation to the values of measurements a and b.
- Two bogie wagons, with 3 or 4 axles per bogie, providing they have reduced mass per axle, Pr, complying with the values given in Annex D Tables D.4 and D.5 in relation to the values of dimensions a and b.
- Wagons with three or four 2-axle bogies provided they have reduced mass per axle, Pr, not exceeding those defined in Annex D Table D.6 in relation to their geometrical characteristics and provided that they also comply with the special regulations governing these types of wagon.

NOTE: As an exception for 20 t axle-loads it is permissible to exceed this limit by up to 0,5 t per axle on Category C lines for:

**▼B**

- 2-axle long wagons with  $14,10 \text{ m} < \text{LOB}$  (length over buffers)  $< 15,50 \text{ m}$  to bring their payload up to 25 t;
- wagons designed for 22,5 t axle-loads to offset the extra tare incurred in making them suitable for such axle-loads.

Wagons having irregular axle spacings not conforming with Annex D Sections D.3, D.4, D.5) shall be subject to additional checks by calculation, to ensure that the maximum bending moments and shear forces on a single beam of any span length do not exceed the values calculated for the wagons defined in Annex D Section D.1). This shall be applied to an unlimited number of wagons.

The maximum payload that can be carried by a wagon, from the point of view of track and structures, is the lowest value resulting from the following formulae:

$$X = n \times P - T$$

$$Y = L \times p - T$$

$$Z = n \times Pr - T$$

where:

n: number of axles of the wagon

p: mass per unit length in t/m

L: length over buffers in m

T: wagon tare in t, rounded up to the first decimal place

P: mass per axle in t

Pr: reduced mass per axle in t

The tare to be taken into account is the average tare, which shall be determined for the following groups of wagons within each major manufacturing series:

- wagons with air brakes,
- wagons with air brakes and a gangway fitted with a screw brake.

The limits for modifications of freight wagons not requiring new approval are listed in Annex II.

Annex D Sections D.6 and D.7 give the load limits for 2-axle wagons and the commonest types of two 2-axle bogie wagons ( $a = 1,80 \text{ m}$ ,  $b = 1,50 \text{ m}$  (see definition in Annex D)) resulting from comparisons.

The value X, Y or Z selected on the basis of the comparison is rounded down either to the nearest half-tonne or to the nearest tenth of a tonne, each contracting entity being free to select either of these alternatives depending on the type of wagon.

However, for insulated, refrigerator or mechanically-refrigerated wagons, tank wagons and closed wagons used for carrying goods in powder form, the X, Y or Z value shall be rounded down to the nearest tenth of a tonne.

The value to be marked on the wagon is not necessarily that established above. In cases where lower load limits exist as a result of the structural characteristics of the wagon or RID regulations (COTIF agreement Annex D Section D.3), it is these lower values that shall be indicated.

Minimum wheelset load for wagons with:

Generally with two axles or more	5,0 t
4-axle and equipped with brake blocks	4,0 t
Greater than 4-axle and equipped with brake blocks	3,5 t



**▼B**

If permitted by the infrastructure register (e.g. specific case of 'rollende Landstrasse')

8-axles	2,0 t
12- axles	1,3 t

4.2.3.3. ***Rolling stock parameters which influence ground based train monitoring systems***

4.2.3.3.1. **Electrical resistance:**

The electrical resistance of each wheelset measured across the treads of the two wheels shall not exceed 0,01 ohm for new or reassembled wheelsets incorporating new components.

These resistance measurements are to be made using an applied voltage of 1,8 to 2,0 volts DC.

4.2.3.3.2. **Hot axle box detection**

**▼M1**

This remains an open point except for wagons which comply with the conditions set out in section 7.6.4.

**▼B**

4.2.3.4. ***Vehicle dynamic behaviour***

4.2.3.4.1. **General**

The dynamic behaviour of a vehicle has strong effects on safety against derailment and running stability. The vehicle dynamic behaviour is determined by

- the maximum speed
- static track features (alignment, track gauge, cant, rail inclination, discrete and periodic track irregularities)
- dynamic track features (horizontal and vertical track stiffness and track damping)
- wheel/rail contact parameters (Wheel and rail profile, track gauge)
- wheel defects (wheel flats, out of roundness)
- mass and inertia of car body, bogies and wheelsets
- suspension characteristic of the vehicles
- distribution of the payload.

In order to ensure safety and running stability, measurements in different operating conditions or comparison studies with a proven design (e. g. simulation/calculation) have to be carried out to assess the dynamic behaviour.

Rolling stock shall have characteristics that enable stable running within the applicable speed limit.

4.2.3.4.2. **Functional and technical specifications**

4.2.3.4.2.1. ***Safety against derailment and running stability***

In order to ensure safety against derailment and running stability the forces between wheel and rail have to be limited. In particular, the forces in question are transverse track forces Y and vertical forces Q.

— **Lateral track force Y**

In order to prevent track shifts, interoperable Rolling stock shall comply with the Prud'homme criteria for the maximum transverse force

$(\sum Y)_{\text{lim}} = \alpha (10 + P/3)$ , where  $\alpha = 0,85$  and P = maximum static axle load

or

**▼ B**

$(H_{2m})_{lim}$  ( $H_{2m}$ ) is the floating mean value of the lateral force in an axle measured over 2m)

This value will be determined by the TSI Infrastructure

In curves, the limit of the quasi-static lateral force on the outer wheel is

$Y_{qst, lim}$

This value will be determined by the TSI Infrastructure

**▼ M1**— **Y/Q forces**

To limit the risk of wheel climb on the rail the quotient of lateral force Y and vertical load Q of a wheel shall not exceed

$(Y/Q)_{lim} = 0,8$  for dynamic on-track tests

$(Y/Q)_{lim} = 1,2$  for stationary tests

**▼ B**— **Vertical force**

The maximum dynamic vertical force exerted on the rail is

$Q_{max}$

This value will be determined by the TSI Infrastructure

In curves the limit of the quasi-static vertical force on the outer wheel is

$Q_{qst, lim}$

This value will be determined by the TSI Infrastructure

4.2.3.4.2.2. *Safety against derailment when running on twisted tracks***▼ M1**

Wagons are able to run on twisted tracks when (Y/Q) for stationary tests does not exceed the limit given in section 4.2.3.4.2.1 in a curve of radius  $R = 150$  m and for a given twisted track:

**▼ B**

for a wheel base of  $1,3 \text{ m} \leq 2a^*$

—  $g_{lim} = 7 \text{ ‰}$  for  $2a^+ < 4\text{m}$

—  $g_{lim} = 20/2a^+ + 2$  for  $2a^+ > 4\text{m}$

—  $g_{lim} = 20/2a^* + 2$  for  $2a^* < 20\text{m}$

—  $g_{lim} = 3 \text{ ‰}$  for  $2a^* > 20 \text{ m}$

The wheelbase  $2a^*$  represents the axle spacing for 2-axle wagons or the distance between the pivot centres of a bogie wagon. The wheelbase  $2a^+$  represents the axle spacing for a bogie.

4.2.3.4.2.3. *Maintenance rules*

The following key parameters essential for safety and running stability shall be maintained according to the maintenance plan:

— suspension characteristics

— body-bogie connections

— tread profile

The maximum and minimum dimensions for wheelsets and wheels for Standard Gauge are given in Annex E.

Cases for other track gauges are found in Section 7.

4.2.3.4.2.4. *Suspension*

Suspension of freight wagons shall be designed such that the values specified in 4.2.2.1.2.2 and 4.2.2.1.2.3 are adhered to in the conditions 'empty' and 'laden to the load limit'. The suspension calculation shall demonstrate that the suspension

**▼ B**

deflection is not exhausted when the wagons are fully loaded and considering dynamic influences.

#### 4.2.3.5. **Longitudinal compressive forces**

##### 4.2.3.5.1. **General**

This parameter describes the maximum longitudinal compressive forces that can be applied on an interoperable freight wagon or an individual vehicle, or group of special coupled vehicles, of an interoperable train-set during a braking or a banking operation, without any risk of derailment.

When subjected to Longitudinal Compressive Forces, the wagon shall continue to run safely. In order to ensure safety against derailment, the wagon or system of coupled wagons shall be assessed by tests, calculations or through comparison with the characteristics of already approved (certified) wagons.

The longitudinal force that can be applied on a vehicle without derailling shall be higher than a threshold value depending on the vehicle design (two axle, bogie wagon, fixed group of vehicles, Combirail, Road- Railer™, etc.) fitted with UIC coupler or accepted central coupler or coupling rod/short couplers.

The conditions to certify the wagons, fixed groups of wagons and coupled groups of wagons are given in section 4.2.3.5.2.

The conditions that affect the maximum longitudinal compressive force that a wagon is capable of withstanding without derailment include:

- cant deficiency
- train and wagon braking system
- system of draw gear and buffers on the wagons or specially coupled wagon-groups
- design characteristics of the wagon
- characteristics of the line
- train driver's handling of the train, especially braking
- wheel/rail contact parameters (wheel and rail profile, track gauge)
- load distribution of the individual freight wagons

Longitudinal compressive forces have a strong effect on safety against derailment of a vehicle. Therefore measurements in different operating conditions have been carried out to find the acceptable limits of longitudinal compressive force that can be applied on a vehicle without risk of derailment. To avoid testing wagons shall correspond with the characteristics of wagons that have been previously approved by national safety authorities or on their behalf, or to be built according to approved design characteristics of wagons and be fitted with approved components such as certified bogies

The reference test is given in Section 6.2. Experience with different wagon-types has resulted in different methods of acceptance depending on factors such as tare weight, length, wheelbase, overhang, distance between pivots etc.

##### 4.2.3.5.2. **Functional and technical specifications**

The subsystem shall withstand the longitudinal compressive forces in the train without derailling or damaging the vehicle. In particular the determining factors are

- transverse wheel/rail forces -Y-
- vertical forces -Q-
- lateral forces on axle-boxes -H<sub>ij</sub>-

**▼B**

- braking forces (due to wheel/rail contact, dynamic braking and different braking groups of the wagons and trains)
- diagonal and vertical buffer forces
- coupling forces  $\pm Z$
- damping of buffer- and coupling forces
- the result of coupler tightness
- the result of coupler slack
- jerks as a result of longitudinal movements in the trains and coupler slack
- Wheel lift
- Axle guide deflection

Longitudinal Compressive Forces (LCF) are influenced by many factors. The different factors are given in the documents for construction and operating conditions of wagons to which it is necessary to certify wagons for normal traffic on different lines and under different conditions.

With the objective to certify wagons for mixed traffic on the European Network, tests on a special testing track, and in running trains on different lines were performed in order to ensure that wagons can withstand a minimum longitudinal force, without derailing. The following definition was made:

Wagons and rakes of wagons (with coupling rod/short coupler between the wagons) fitted with screw couplings and side-buffers at their outer ends, shall withstand a minimum longitudinal force measured in the conditions of the reference test of:

- 200 kN for two-axle freight wagons with UIC coupling
- 240 kN for freight wagons fitted with two-axle bogies with UIC coupling
- 500 kN for freight wagons with all types of central bar couplers and without buffers

For other coupling systems, limit values are not yet defined.

The coefficient of friction of the buffer heads shall be such as to meet the requirements of this TSI in terms of maximum lateral forces.

Maintenance rules:

If the buffer heads have to be lubricated in order to ensure the required coefficient of friction, then the maintenance plan shall include provision for maintaining the coefficient of friction at this level.

#### 4.2.4. BRAKING

##### 4.2.4.1. *Braking performance*

##### 4.2.4.1.1. **General**

The purpose of the train braking system is to ensure that the train's speed can be reduced or it can be stopped within the maximum allowable braking distance. The primary factors that influence the brake process are the braking power, the train mass, the speed, the allowable braking distance, the adhesion and the track gradient.

Braking performance of a train or a vehicle is the result of the braking power available to retard the train within defined limits and all factors involved in the conversion and dissipation of energy including train resistance. Individual vehicle performance is defined so that the overall braking performance of the train can be derived.

**▼B**

Vehicles shall be equipped with continuous automatic brake.

A brake is continuous if it allows the transmission of signals and energy from central command unit to the whole train.

A continuous brake is automatic, if it becomes effective immediately on the whole train with every inadvertent break of the control train line, e. g. brake-pipe.

Where it is not possible to detect the state of the brake, an indicator showing the state shall be provided on both sides of the vehicle.

The brake energy storage (e.g. supply reservoirs of indirect pneumatic air brake system, brake pipe air) and the brake energy used to build up the brake effort (e.g. air from brake cylinders of indirect pneumatic air brake system) shall be used only for braking use.

#### 4.2.4.1.2. Functional and Technical Specification

##### 4.2.4.1.2.1. Control train line

The minimum propagation braking signal speed shall be 250 m/s.

##### 4.2.4.1.2.2. Braking Performance elements

Braking performance shall take into account mean application time, instantaneous deceleration, mass and initial speed. Braking performance shall be determined by both deceleration profiles and by braked mass percentage.

#### Deceleration profile:

The deceleration profile describes the predicted instantaneous deceleration of the vehicle (at the level of a vehicle) or the train (at the level of a train) in normal conditions.

Knowledge of individual vehicle deceleration profiles enables the calculation of the overall train deceleration profile.

The deceleration profile includes the effect of:

- a) the response time between brake demand and reaching full brake effort.

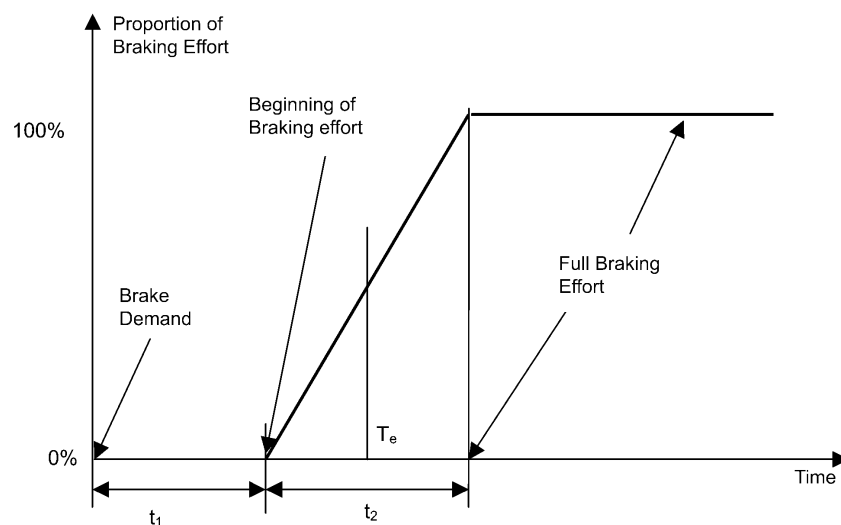

$T_e$  is the equivalent build-up application time and is defined as:

$$T_e = t_1 + (t_2/2)$$

For pneumatic brake the end of the time  $t_2$  corresponds to 95 % of established brake cylinder pressure.

**▼ B**

- b) the corresponding function (*deceleration* =  $F(\text{speed})$ ) as defined as a succession of sections with a constant deceleration.

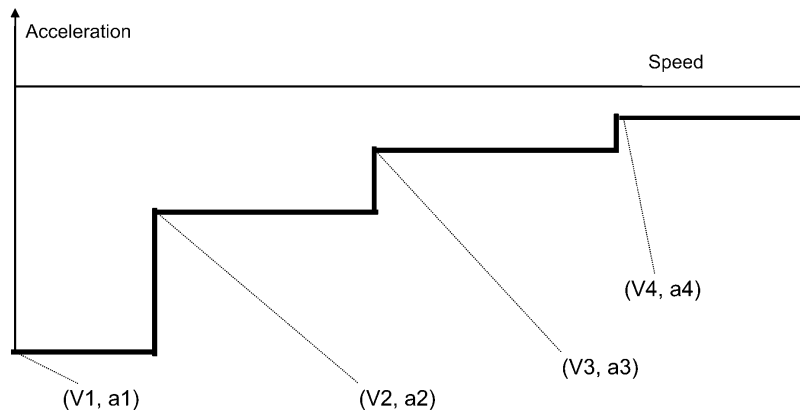

Note: a denotes the instantaneous deceleration and V the instantaneous speed

**Brake mass percentage:**

The brake mass percentage ( $\lambda$ ) is the ratio of the sum of the brake masses divided by the sum of the masses of the vehicles.

The method of determining the brake mass/brake mass percentage shall remain applicable in addition to the method of deceleration profiles; the manufacturer shall supply these values. This information is required to be entered in the Rolling Stock Register.

Braking power for an individual vehicle shall be determined in emergency braking for each braking mode (i.e. G, P, R, P + ep) available on the vehicle and for several loading conditions including at least tare and fully loaded.

**G braking mode:** brake mode used for freight trains with specified brake application time and brake release time.

**P braking mode:** brake mode for freight trains with specified brake application time and brake release time and specified brake mass percentage.

**R braking mode:** brake mode for passenger trains and fast freight trains with specified brake application time and brake release time as for braking mode P and specified minimum brake mass percentage.

**Ep brake (indirect Electro-pneumatic brake):** assistance to indirect air brake that uses an electrical command on the train and electro-pneumatic valves on the vehicle and thus starts operating more rapidly and less jerkily than the conventional air brake.

**Emergency braking:** Emergency braking is a brake command that stops the train to ensure the specified level of safety without any brake system degradation.

The minimum braking performance for brake-modes G and P: shall be in accordance with the following table:

Braking Mode — $T_e$ range (s)	Wagon Type	Command Equipment	Load	Requirement for running speed at 100km/h		Requirement for running speed at 120km/h	
				Maxi	Mini	Maxi	Mini
Braking mode 'P' - $1,5 \leq T_e \leq 3$ s	All	All	EMPTY	<b>S = 480m</b> $\lambda = 100\%$ (1) $\gamma = 0,91 \text{ m/s}^2$ (1)	<b>Case A — composite blocks:</b> <b>S = 390 m</b> , $\lambda = 125\%$ , $\gamma = 1,15 \text{ m/s}^2$ <b>Case B — other cases:</b> <b>S = 380 m</b> , $\lambda = 130\%$ , $\gamma = 1,18 \text{ m/s}^2$	<b>S = 700 m</b> $\lambda = 100\%$ $\gamma = 0,88 \text{ m/s}^2$	<b>Case A — composite blocks:</b> <b>S = 580 m</b> , $\lambda = 125\%$ , $\gamma = 1,08 \text{ m/s}^2$ <b>Case B — other cases:</b> <b>S = 560 m</b> , $\lambda = 130\%$ , $\gamma = 1,13 \text{ m/s}^2$
	'S1' (2)	Empty/ Load Device	Intermediate Load	<b>S = 810 m</b> $\lambda = 55\%$ $\gamma = 0,51 \text{ m/s}^2$	<b>Case A — composite blocks:</b> <b>S = 390 m</b> , $\lambda = 125\%$ , $\gamma = 1,15 \text{ m/s}^2$ <b>Case B — other cases:</b> <b>S = 380 m</b> , $\lambda = 130\%$ , $\gamma = 1,18 \text{ m/s}^2$		
				LOADED (Maximum 22,5 t/axle)	<b>S = 700 m</b> $\lambda = 65\%$ $\gamma = 0,60 \text{ m/s}^2$	<b>Case A — Brake only on wheels (Brake blocks):</b> <b>S = greater of (S = 480 m, <math>\lambda = 100\%</math>, <math>\gamma = 0,91 \text{ m/s}^2</math>) or (S obtained with a mean retardation force of 16,5 kN per axle (3)).</b> <b>Case B — Other cases:</b> <b>S = 480 m</b> , $\lambda = 100\%$ , $\gamma = 0,91 \text{ m/s}^2$	
	'S2' (3)	Variable load Relay	LOADED (Maximum 22,5 t/axle)	<b>S = 700m</b> $\lambda = 65\%$ $\gamma = 0,60 \text{ m/s}^2$	<b>Case A — Brake only on wheels (Brake blocks):</b> <b>S = greater of (S = 480 m, <math>\lambda = 100\%</math>, <math>\gamma = 0,91 \text{ m/s}^2</math>) or (S obtained with a mean retardation force of 16,5 kN per axle (3)).</b> <b>Case B — Other cases:</b> <b>S = 480 m</b> , $\lambda = 100\%$ , $\gamma = 0,91 \text{ m/s}^2$		



Braking Mode — T <sub>e</sub> range (s)	Wagon Type	Command Equipment	Load	Requirement for running speed at 100km/h	Requirement for running speed at 120km/h
	'SS' (4)	Variable load relay	LOADED (Maximum 22,5 t/axle)		<p><b>Case A — Brake only on wheels (Brake blocks):</b> S = greater of (S = 700 m, λ = 100 %, γ = 0,88 m/s<sup>2</sup>) or (S obtained with a mean retardation force of 16 kN per axle (6)).</p> <p><b>Case B — Other cases:</b> S = 700 m, λ = 100 %, γ = 0,88 m/s<sup>2</sup></p>
Braking mode 'G' — 9 ≤ T <sub>e</sub> ≤ 15 s				There shall be no separate assessment of the braking power of wagons in position G. A wagon's braked mass in position G shall be the same as braked mass in position P	

(1) S is obtained according annex S, 'λ' = ((C/S)-D) according annex S, 'γ' = ((Speed (Km/h)/3,6)<sup>2</sup>/(2x(S-(Te) × (Speed (Km/h)/3,6))), with Te=2sec.

(2) a wagon 'S1' is a wagon with Empty/load device

(3) a wagon 'S2' is a wagon with a variable load relay

(4) a wagon 'SS' shall be equipped with a variable load relay.

(5) The maximum mean retardation force admitted (for running speed at 100km/h) is 18 × 0,91 = 16,5 kN/axle. This value comes from the maximum braking energy input permitted on a clasp braked wheel with a nominal new diameter in the range of [920 mm; 1 000 mm] during braking (the brake mass shall be limited to 18 tonnes). Wheels with a nominal new diameter (< 920 mm) and/or push brakes shall be accepted in accordance with national rules.

(6) The maximum mean retardation force admitted (for running speed at 120km/h) is 18 × 0,88 = 16 kN/axle. This value comes from the maximum braking energy input permitted on a clasp braked wheel with a nominal new diameter in the range of [920 mm; 1 000 mm] during braking (the brake mass shall be limited to 18 tonnes). Wheels with a nominal new diameter (< 920 mm) and/or push brakes shall be accepted in accordance with national rules.



**▼B**

This table is based on a reference speed of 100 km/h and an axle load of 22,5 t and 120 km/h and an axle load of 22,5 t. Higher axle loads can be accepted under specific operational conditions in accordance with national rules. The permitted maximum axle load shall be in accordance with the infrastructure requirements.

If a wagon is equipped with a WSP, the above performance shall be achieved without activation of the WSP and according to the conditions in annex S.

Other braking modes (example: R braking mode) are permitted according to national rules and the mandatory use of WSP as specified in § 4.2.4.1.2.6.

**Brake Pipe Emptying Accelerator valve**

If the brake pipe-emptying accelerator is separately installed on the wagon, it shall be capable of isolation from the brake pipe by a specific device. The wagon shall be clearly marked to indicate this isolation device, or this device shall be secured in an 'open' position by a seal.

4.2.4.1.2.3. *Mechanical components*

The assembly of brake components shall be aimed to prevent any partial or full detachment of these components.

— **Slack adjuster**

A device to automatically maintain the design clearance between the friction pair shall be provided.

A minimum of 15 mm clearance between the slack adjuster envelope and other components shall be provided.

Provision shall be made for the necessary free clearances for the slack adjuster extremities and connections to be maintained at all times.

For slack adjusters within a bogie, there is no special envelope. But, for all design conditions, the minimum clearance necessary between the slack adjuster and other components shall be ensured to prevent contact. Should a smaller clearance be required, the reasons why contact will not occur shall be demonstrated.

— **Pneumatic half coupling**

The opening of the automatic air brake coupling head shall face the left when looking at the end of the vehicle. The opening of the main reservoir coupling head shall face the right when looking at the end of the vehicle.

The vehicles shall be fitted with devices to enable the unused couplings to be suspended at least 140 mm above rail level to prevent both damage and, as far possible, penetration of foreign bodies into the interior coupling.

4.2.4.1.2.4. *Energy storage*

The energy storage shall be sufficient to obtain during an emergency braking at maximum speed, whatever the loaded state of the vehicle, the maximum brake effort without any further supply of energy (e.g. for indirect compressed air brake system: Brake Pipe only without replenishment by main reservoir pipe). When a vehicle is equipped with WSP the above condition applies with the WSP fully operational (i.e. WSP air consumption).

4.2.4.1.2.5. *Energy limits:*

The brake system shall be designed to allow the vehicle to run on all existing lines of the trans-European conventional rail system.

The brake system shall stop the vehicle loaded and maintain the speed of the vehicle without any thermal or mechanical damage in

**▼ B**

the following conditions:

1. Two successive emergency braking applications from the maximum speed to a stop on straight and level track with minimum wind and dry rail.
2. Maintain a speed of 80 km/h in a slope with a mean declivity of 21 ‰ and a length of 46 km. (The south slope of St Gothard's line between Airolo and Biasca is the reference slope.)

#### 4.2.4.1.2.6. *Wheel slide protection (WSP)*

Wheel slide protection (WSP) is a system designed to make the best use of available adhesion by a controlled reduction and restoration of the brake force to prevent wheelsets from locking and uncontrolled sliding, thereby optimising stopping distance. The WSP shall not alter the functional characteristics of the brakes. The vehicle's air equipment shall be dimensioned such that the air consumption of the WSP does not impair the performance of the pneumatic brake. The design process of the WSP shall take into account that the WSP shall not have a detrimental effect on the constituent parts of the vehicle (brake gear, wheel tread, axle boxes, etc).

The following types of wagons shall be fitted with WSP:

- a) equipped with brake blocks made of cast iron or sintered material, for which the maximum mean utilisation of adhesion ( $\delta$ ) is greater than 12 % ( $\text{Lambda} \geq 135$  %). The maximum mean utilisation of adhesion is shown by calculating the mean adhesion ( $\delta$ ) from individual braking distances obtained from the possible range of vehicle mass.  $\delta$  is therefore related to the measured braking distances necessary for determining the braking performance. ( $\delta = f(V, T_e, \text{Stopping distance})$ ).
- b) equipped with disc brakes only, for which the maximum utilisation of adhesion (see above for the definition of the maximum utilisation of adhesion ( $\delta$ )) is greater than 11 % and less than 12 % ( $125 < \text{Lambda} \leq 135$  %).
- c) With maximum operating speed  $\geq 160$  km/h.

#### 4.2.4.1.2.7. *Air-supply*

Freight wagons shall be designed to be able to work with compressed air compliant at least with class 4.4.5 as defined by ISO 8573-1.

#### 4.2.4.1.2.8. *Parking Brake*

A Parking Brake is a brake used to prevent parked rolling stock moving under the specified conditions taking into account the place, wind, gradient and rolling stock loading state, until intentionally released.

It is not compulsory for all wagons to be equipped with a parking brake. Operational rules, taking into account the fact that not all wagons in a train are equipped with these brakes, are described in the Traffic Operation and Management TSI.

If the wagon is equipped with a parking brake, it shall meet the following requirements.

The power source for providing the parking brake effort shall be derived from a different power source than the Automatic Service/Emergency brake.

The parking brake shall operate on at least half of the wheelsets, with a minimum of 2 wheelsets per wagon.

Where it is not possible to see the state of the parking brake, an indicator showing the state shall be provided on both sides on the outside of the vehicle.

**▼B**

The wagon parking brake shall be accessed and operated from the ground or on the vehicle. Handles or hand wheels shall be used to operate the parking brake, but only hand wheels may be used for brakes operated from the ground. Parking brakes that are accessible from the ground shall be available on both sides of the vehicle. Handles or hand wheels shall apply the brakes when they are turned in a clockwise direction.

Where the parking brake controls are fitted inside a vehicle, they shall be accessible from both sides of the vehicle. Where the parking brake can be superimposed with other brake applications, either whilst moving or statically, the vehicle equipment shall be able to withstand the imposed loads for the life of the vehicle.

It shall be possible to release the parking brake manually in an emergency situation at standstill.

The parking brake shall conform to the table below

Wagon not specifically listed below.	At least 20 % of a fleet of wagons shall have a parking brake operated from the wagon (platform or gangway) or the ground,.
Wagons built specifically for the transport of loads requiring precautions as follows or/and according to Council Directive 96/49/EC (RID): Livestock; fragile loads; compressed or liquefied gases; materials which give off inflammable gases when in contact with water causing combustion; acids; corrosive or combustible liquids; loads igniting spontaneously, catching fire or exploding easily.	One per wagon operated from the vehicle (platform or gangway)
Wagons whose special fittings for accommodating the load shall be treated with caution, i.e. carboy, jar or cask wagons; tanks of aluminium; tanks lined with ebonite or enamel; crane wagons. (or/and according to Council Directive 96/49/EC (RID))	One per wagon operated from the wagon (platform or gangway).
Wagons with a superstructure built specifically for the transport of road vehicles, including the multi-deck wagons for the transport of motor cars.	One per wagon operated from the wagon (platform or gangway) and 20 % of these having the parking brake also operated from the wagon floor.
Wagons for the transport of de-mountable swap bodies for horizontal transshipment.	One per wagon operated from the ground.
Wagons comprising several permanently coupled units	A minimum of two axles (on one unit)

The parking brake shall be designed such that fully loaded wagons shall be held in a gradient of 4,0 % with maximum adhesion of 0,15 with no wind.

**▼ B**

## 4.2.5. COMMUNICATION

4.2.5.1. *Vehicle capability to transmit information from vehicle to vehicle*

This parameter is not yet applicable for freight wagons.

4.2.5.2. *Vehicle capability to transmit information between ground and vehicle*4.2.5.2.1. **General**

Application of tags is not mandatory. If a wagon is fitted with radio-frequency identification devices (RFID-tag), the following specification shall be applied.

4.2.5.2.2. **Functional and technical specification**

Two ‘passive’ tags shall be fitted, one on each side of the wagon in the areas indicated in Annex F figure F.1, such that the unique identification number of the wagon can be read by a trackside device (the *tag reader*).

When available, trackside devices (*tag reader*) shall be capable of decoding tags passing at a speed of up to 30 km/h and make this decoded information available to a ground-based data transmission system.

Typical installation constraints are given in the Annex F figure F.2 where the reader position is defined by a cone.

The physical interactions between the reader and the tag, the protocols and the commands, and the collision arbitration schemes, shall conform to ISO18000-6 type A.

When fitted, tag readers shall be positioned at entry and exit points of locations where train formation can be changed.

The tag reader shall provide at a minimum to the interface with any data transmission system the following:

- Unambiguous identification of the tag reader, among those that may be installed in the same location, in order to identify the track being monitored,
- Unique identification of every wagon passing,
- Time and date for each wagon passing.

Time and date information shall be accurate enough in order that a subsequent processing system is able to identify the actual physical train composition.

4.2.5.2.3. **Maintenance rules**

Inspections according to the maintenance plan shall include:

- presence of tags
- correct response
- processes to ensure that tags will not be degraded during the maintenance procedures

## 4.2.6. ENVIRONMENTAL CONDITIONS

4.2.6.1. *Environmental conditions*4.2.6.1.1. **General**

The design process of the rolling stock, as well as the on-board equipment, shall take into account that this rolling stock shall be able to be put into service and operate normally in the conditions and climatic zones for which the equipment is designed and in which it is likely to run, as specified in this TSI.

**▼ B**

The environmental conditions are expressed in classes for temperature etc. thereby giving the choice for the operator to procure a vehicle suitable for operation all over Europe, or have a restricted use.

The 'Register of Infrastructure' will specify the ranges of environmental conditions likely to be experienced on the individual lines. The same ranges will be used to assist reference to operating rules.

The range limits specified are those which have a low probability of being exceeded. All specified values are maximum or limit values. These values may be reached, but do not occur permanently. Depending on the situation there may be different frequencies of occurrence related to a certain period of time.

#### 4.2.6.1.2. **Functional and technical specifications**

##### 4.2.6.1.2.1. *Altitude*

The wagons shall perform as specified for all altitudes up to 2000 m.

##### 4.2.6.1.2.2. *Temperature*

All freight wagons intended for international traffic shall comply as a minimum with temperature class  $T_{RIV}$ .

The class  $T_{RIV}$  is identical to the temperature design level of all RIV compliant wagons existing before implementation of this TSI. The design level for class  $T_{RIV}$  is given in Annex O.

In addition to design level class  $T_{RIV}$  the external temperature classes  $T_s$  and  $T_n$  exists.

Classes	Design level classes
$T_{RIV}$	Subsystems and components have different temperature requirements. Details are given in Annex O
	<b>Air temperature range external to vehicle [ °C]:</b>
$T_n$	-40 + 35
$T_s$	-25 + 45

A  $T_{RIV}$  wagon is permitted to operate in:

- permanent use on  $T_s$  lines.
- permanent use on  $T_n$  lines in the period of the year when temperature is expected to be above - 25 °C.
- non-permanent use on  $T_n$  lines in the period of the year when temperature is expected to be below - 25 °C.

Remark: It will be the choice of the contracting entity to decide the additional temperature range of the wagon according to its intended use ( $T_n$ ,  $T_s$ ,  $T_n + T_s$ , or nothing more than  $T_{RIV}$ ).

##### 4.2.6.1.2.3. *Humidity*

The following external humidity levels shall be considered:

Yearly average:  $\leq 75$  % relative humidity.

On 30 days in the year continuously: between 75 % and 95 % relative humidity.

On the other days occasionally: between 95 % and 100 % relative humidity

**▼B**

Maximum absolute humidity: 30 g/m<sup>3</sup> occurring in tunnels.

An operationally caused infrequent and slight moisture condensation shall not lead to any malfunction or failure.

The psychometric charts of Annex G fig. G1 and G2 give the range of variation of the relative humidity for the different temperature classes that it is considered will not be exceeded for more than 30 days per year.

At cooled surfaces, 100 % relative humidity may occur causing condensation on parts of equipment; this shall not lead to any malfunction or failure.

Sudden changes of the air temperature local to the vehicle may cause condensation of water on parts of equipment with rate of 3 K/s and maximum variation of 40 K.

These conditions occurring particularly when entering or leaving a tunnel shall not lead to any malfunction or failure of the equipment.

4.2.6.1.2.4. *Air movement*

For wind speeds to be considered for the design of freight wagons refer to section Aerodynamic effects.

4.2.6.1.2.5. *Rain*

A rain rate of 6 mm/min shall be taken into account. The effect of rain shall be considered depending on the equipment installation together with wind and vehicle movement.

4.2.6.1.2.6. *Snow, ice and hail*

Consideration shall be given to the effect of all kinds of snow, ice and/or hail. The maximum diameter of hailstones shall be taken as 15 mm, larger diameters may occur exceptionally.

4.2.6.1.2.7. *Solar radiation*

Equipment design shall allow for direct exposure to solar radiation at the rate of 1 120 W/m<sup>2</sup> for a maximum duration of 8h.

4.2.6.1.2.8. *Resistance to Pollution*

The effects of pollution shall be considered in the design of equipment and components. The severity of pollution will depend upon the location of the equipment. Means may be provided to reduce pollution by the effective use of protection. The effects of the following kinds of pollution shall be considered:

Chemically active substances	Class 5C2 of EN 60721-3-5:1997.
Contaminating fluids	Class 5F2 (electrical engine) of EN 60721-3-5:1997. Class 5F3 (thermal engine) of EN 60721-3-5:1997.
Biologically active substances	Class 5B2 of EN 60721-3-5:1997.
Dust	Defined by class 5S2 of EN 60721-3-5:1997.
Stones and other objects	Ballast and other of maximum 15 mm diameter.
Grasses and leaves, pollen, flying insects, fibres etc.	For the design of ventilation ducts
Sand	According to EN 60721-3-5:1997.
Sea spray	According to EN 60721-3-5:1997 Class 5C2.

**▼ B**4.2.6.2. ***Aerodynamic effects***

Open point to be specified at the next revision of this TSI.

4.2.6.3. ***Cross winds***

Open point to be specified at the next revision of this TSI.

## 4.2.7. SYSTEM PROTECTION

4.2.7.1. ***Emergency Measures***

There is no requirement for emergency exits or signposting relating to emergency exits on freight wagons. However, in the event of an accident, there is a requirement for a rescue plan and related information notices.

4.2.7.2. ***Fire safety***4.2.7.2.1. **General**

- Design shall limit fire ignition and propagation.
- Toxic fume requirements are not described by this TSI
- The goods carried on freight wagons shall not be taken into account — neither as a primary ignition source nor as a mean of feeding fire propagation. In the case of dangerous goods carried on freight wagons, RID requirements shall be applied in all aspects of fire safety.
- The goods of freight wagons shall be protected against foreseeable sources of ignition on the vehicle.
- The material used on freight wagons shall limit the generation, propagation of fire, and production of smoke in the event of fire on primary ignition source of 7 kW during 3 min
- The design rules shall be applied for any fixed equipment of the vehicle, if it is a potential source of fire ignition, e.g. cooling devices containing fuel.
- A Member State shall not require smoke detectors to be installed on freight wagons.
- Flexible covers shall not be required to meet any fire criteria
- Floors material shall not be required to meet any fire criteria if they are protected according the first sentence of section 4.2.7.2.2.3.

4.2.7.2.2. **Functional and technical specification**4.2.7.2.2.1. *Definitions***Fire integrity:**

The ability of a separating construction element, when exposed to fire on one side, to prevent the passage through it of flames, hot gases and other fire effluents or the occurrence of flames on the unexposed side.

**Thermal insulation:**

The ability of a separating construction element to prevent excessive transmission of heat.

4.2.7.2.2.2. *Normative References*

1	EN 1363-1 October 1999	Fire resistance tests Part 1: General requirements
2	EN ISO 4589-2 October 1998	Determination of burning behaviour by oxygen index Part 2: Ambient temperature test

**▼ B**

3	ISO 5658-2 1996-08-01	Reaction to fire tests — Spread of flame  Part 2 Lateral spread on building products in vertical configuration
4	EN ISO 5659-2 October 1998	Plastic — Smoke generation  Part 2: Determination of optical density by a single chamber test
5	EN 50355 November 2002	Railway applications — Railway rolling stock cables having special fire performance — Thin wall and standard wall — Guide to use

4.2.7.2.2.3. *Design rules*

Spark protection of the load shall be provided separately where the floor does not provide that protection.

The underside of the vehicle floor, in those locations where it is exposed to potential sources of fire and when spark protection is not provided, shall be provided with thermal insulation and fire integrity according to the heat curve of EN 1363-1 [1] with a duration of 15 minutes.

4.2.7.2.2.4. *Material requirement*

In the following table the parameters used to define requirements and their characteristics, are listed. Also stated is whether the numerical value in the tables of requirements represents a maximum or minimum for compliance.

A reported result equal to the requirement is compliant.

Test Method	Parameter	Units	Requirement definition
EN ISO 4589-2 [2]	LOI	% Oxygen	minimum
ISO 5658 [3]	CFE	KWm <sup>-2</sup>	minimum
EN ISO 5659-2 [4]	D <sub>s max</sub>	Dimensionless	maximum

**A short explanation of the test methods is given below:**

— **EN ISO 4589-2 [2] Determination of burning behaviour by oxygen index**

This test specifies methods for determining the minimum concentration of oxygen, in ad-mixture with nitrogen, which will support combustion of small vertical test specimens under specified test conditions. The test results are defined as oxygen index values by volume percentages.

— **ISO 5658 –2 [3] Reaction to fire tests — Spread of flame-part 2 Lateral spread on products in vertical position**

This test specifies a method of test for measuring the lateral spread of flame along the surface of a specimen of product orientated in vertical position. It provides data suitable for comparing the performance of essentially flat materials, composites or assemblies, which are used primarily as the exposed surfaces of walls.

— **EN-ISO 5659-2 [4] Smoke generation part 2 Determination of optical density by a single-chamber test.**

The specimen of the product is mounted horizontally within a chamber and exposed to thermal radiation on their upper surfaces at selected levels of constant irradiance of 50 kW/m<sup>2</sup> in the absence of a pilot flame.



**▼ B****Minimum Requirements**

Parts or materials having a surface area less than the surface classification below, shall be tested with minimum requirements

Test Method	Parameter	Unit	Requirement
EN ISO 4589-2 [2]	LOI	% Oxygen	≥ 26

**Requirements for material used as surface**

Method: Conditions Parameter	Parameter	Unit	Requirement
ISO 5658-2 [3] CFE	CFE	kWm <sup>-2</sup>	≥ 18
EN ISO 5659-2 [4] 50kWm <sup>-2</sup>	D <sub>s</sub> max	Dimensionless	≤ 600

**Surface classification**

All materials used shall meet the minimum requirements where the surface area of the material/item is less than 0,25m<sup>2</sup> and

on a ceiling:

- the maximum dimension in any direction on the surface is less than 1m and
- the separation from another surface is greater than the maximum extent of the surface (measured horizontally in any direction on the surface).

on a wall:

- the maximum dimension in a vertical direction is less than 1m and
- the separation from another surface is greater than the maximum extent of the surface (measured vertically)

If a surface is larger than 0,25 m<sup>2</sup>, then requirements for material used as surface applies.

**Cable requirements**

Cable used for electrical installation on freight wagons shall be in accordance with EN 50355 [5]. For fire safety requirements the hazard level 3 shall be taken in account.

4.2.7.2.2.5. *Maintenance of the fire protection measures*

The condition of fire integrity and thermal insulation measures (e. g. floor protection, wheel spark protection) shall be checked every overhaul period and at intermediate periods where it is appropriate to the design solution and field experience.

4.2.7.3. *Electrical protection*4.2.7.3.1. **General**

All the metallic parts of a freight wagon that are at risk from excessive contact voltages or being at risk of causing accidents caused by electrical charges of any origin, shall be held at the same voltage as the rail.

4.2.7.3.2. **Functional and technical specifications**4.2.7.3.2.1. *Freight wagon bonding*

The electrical resistance between the metallic parts and the rail shall not exceed 0,15 ohm.

These values shall be measured using 50 A direct current.

**▼B**

When materials that are poor conductors do not enable the above values to be reached, the vehicles themselves shall be fitted with the following protective bonding connections:

- The body shall be connected to the frame at least two different points;
- The frame shall be connected to each bogie at least once.

Each bogie shall be bonded reliably by means of at least one axle box. If there are no bogies, no bonding connections are needed.

Each bonding connection shall be made of a flexible and non-corrodible or corrosion protected material and have a minimum cross section according to the materials used (the reference is 35 mm<sup>2</sup> for copper).

Particularly restrictive conditions, from the point of view of eliminating risks, shall be taken in the case of special vehicles, for example roofless vehicles occupied by passengers in their own cars, vehicles used to transport dangerous goods (listed in the directive 96/49 EC and its valid Annex RID.).

#### 4.2.7.3.2.2. *Freight wagon electrical equipment bonding*

**Freight wagons fitted with electrical equipment shall have sufficient protection against electric shocks.** Where there is an electrical installation on the freight wagon, any metallic parts of the electrical equipment liable to be touched by people shall be reliably bonded, if the standard voltage to which they may be subjected is higher than:

- 50 V dc
- 24 Vac
- 24 V between phases when the neutral point is not bonded
- 42 V between phases when the neutral point is bonded.

The cross-section of the bonding cable will depend on the current in the electrical installation, but shall be of a suitable size to ensure reliable operation of the circuit protect devices, in the event of a fault.

Any aerials fitted outside the freight wagons shall be completely protected from the voltage of the catenary or 3rd rail and the system shall form an electrical single unit bonded at one single point. An antenna fitted outside of the freight wagon that does not conform to the previous conditions, shall be isolated.

#### 4.2.7.4. *Fixing of tail lamps*

##### 4.2.7.4.1. **General**

All hauled vehicles shall have two tail lamp brackets at each end

##### 4.2.7.4.2. **Functional and technical specifications**

###### 4.2.7.4.2.1. *Characteristics*

The tail lamp bracket shall have a fixing slot, as defined in Annex BB fig. BB1.

###### 4.2.7.4.2.2. *Position*

At the vehicle ends, the tail lamp brackets shall be arranged in such a way that:

- they are placed, wherever possible, between the buffers and the corners of the vehicles;
- they are spaced more than 1 300 mm apart;
- the main centre line of the slot is perpendicular to the main centre line of the wagon;
- the upper side of the tail lamp bracket is less than 1 600 mm above rail level. Where vehicles are fitted with fixed electric

**▼B**

tail lamps, the centre line of the tail lamp shall be less than 1 800 mm above rail level;

- the overall gauge of the tail lamp, as laid down in Annex BB fig. BB2, is complied with.

The tail lamp brackets shall be located in such a position that the lamp, when fitted, is not obscured and is easily accessible.

4.2.7.5. ***Provisions for the hydraulic/pneumatic equipment of freight wagons***

4.2.7.5.1. **General**

Hydraulic and pneumatic equipment shall be so designed by structural strength and using suitable fittings so that bursting will not occur in normal operation.

Hydraulic systems installed on wagons shall be so designed to avoid any visible signs of leaking of hydraulic fluid.

4.2.7.5.2. **Functional and technical specifications**

Suitable protective measures shall ensure that hydraulic/pneumatic systems are not actuated inadvertently.

For hydraulically or pneumatically operated flaps/slide valves, an indicator shall show that they are properly locked.

4.2.8. MAINTENANCE: MAINTENANCE FILE

All maintenance activities undertaken on Rolling Stock must be performed in accordance with the provisions of this TSI.

All maintenance shall be undertaken in accordance with the Maintenance File applicable to the Rolling Stock.

The Maintenance File must be managed in accordance with the provisions specified in this TSI.

After delivery of the rolling stock by the supplier, and acceptance thereof, a single entity shall assume responsibility for the maintenance of the rolling stock and management of the Maintenance File.

The Rolling Stock Register, kept by each Member State, shall state the entity responsible for the maintenance of the Rolling Stock and the management of the Maintenance File.

4.2.8.1. ***Definition, contents and criteria of the Maintenance File***

4.2.8.1.1.1. *Maintenance File*

The maintenance file shall be supplied with the vehicle, which is submitted to the verification process as specified in section 6.2.2.3 of this TSI, before putting into service.

The present article gives the criteria to verify the maintenance file.

The maintenance file is composed of:

— **The Maintenance Design Justification File.**

The Maintenance Design Justification File describes the methods used to design the maintenance; describes the tests, investigations, calculations carried out; gives the relevant data used for this purpose and justifies their origin.

This file shall contain:

- Description of the organisation in charge of the design of the maintenance
- Precedents, principles and methods used to design the maintenance of the vehicle.
- Utilisation profile (Limits of the normal utilisation of the vehicle (km/month, climatic limits, authorised types of

**▼ B**

loads...) taken into account for the design of the maintenance).

- Tests, investigations, calculations carried out.
- Relevant data used to design the maintenance and origin of these data (return of experience, tests...).
- Responsibility and traceability of the design process (name, skills and position of the author and approver of each document).

— **The Maintenance Documentation.**

The Maintenance Documentation consists of all the documents necessary to realise the management and execution of the maintenance of the vehicle.

The maintenance documentation is composed of the following:

- Organic/functional description (breakdown structure).

The breakdown structure sets up the borders of the freight wagon by listing all the items belonging to the structure of that freight wagon and using an appropriate number of discrete levels to distinguish the relationships existing between different areas of the rolling stock. The last item identified along a branch shall be a Replaceable Unit.

- Parts List.

Containing the technical descriptions of the spare parts (replaceable units) in order to allow identification and procurement of the correct spares.

- Safety/interoperability-relevant limits.

For the safety/interoperability relevant components or parts, this document shall give the measurable limits not to be exceeded in service (to include operation in degraded mode).

- Legal obligations.

Some components or systems are subject to legal obligations (for instance brakes reservoirs, dangerous goods tanks ...). These obligations shall be listed.

- Maintenance plan

- List, schedule and criteria of planned preventative maintenance operations,

- List and criteria of conditional preventative maintenance operations,

- List of corrective maintenance operations,

- Maintenance operations governed by specific conditions of use.

The level of the maintenance operations shall be described. Also maintenance tasks to be carried out by the Railway Undertaking (servicing, inspections, brake tests, etc...) shall be described.

Note: Some maintenance operations like overhauls (level 4) and refurbishment, transformation or very heavy repairs (level 5) may not be defined at the moment when the vehicle is put into service. In this case, the responsibility and the procedures to define such maintenance operations shall be described.-

- Maintenance manuals and leaflets

For each maintenance operation listed in the maintenance plan, the manual explains the list of the tasks to be carried out.

**▼B**

Some maintenance tasks may be common to different operations or common to different vehicles. These tasks are explained in specific maintenance leaflets.

The manuals and leaflets shall contain the following information:

- Specific tools and facilities
- Standardised or statutory specific staff competencies required (welding, non destructive testing...)
- General requirements relative to Mechanical, Electrical, Fabrication and other engineering competencies.
- Occupational and Operational Health and Safety provisions (including, but not limited to applicable legislation appertaining to the controlled use of substances hazardous to health and safety).
- Environmental provisions
- Details of the task to be carried out as a minimum:
  - Disassembly/assembly instructions
  - Maintenance criteria
  - Checks and tests
  - Parts required to undertake the task
  - Consumables required to undertake the task
- Tests and procedures to be undertaken after each maintenance operation before putting into service.
- Traceability and Records.
- Troubleshooting (fault diagnosis) manual
  - Including functional and schematic diagrams of the systems.

#### 4.2.8.1.2. **Management of the Maintenance File.**

In the case where Railway Undertakings carry out maintenance on the Rolling Stock they use, the Railway Undertaking shall ensure processes are in place to manage the maintenance and operational integrity of the Rolling Stock, including:

- Information in the Rolling Stock Register,
- Asset Management, including records of all Maintenance undertaken and due on the Rolling Stock (which shall be subject to specified time periods for differing levels of archive storage).
- Software where relevant.
- Procedures for the receipt and processing of specific information related to the operational integrity of Rolling Stock, arising as a result from any circumstance including but not limited to operational or Maintenance incidents, that have a potential to affect the safety integrity of Rolling Stock.
- Procedures for the identification, generation and dissemination of specific information related to the operational integrity of Rolling Stock, arising as a result from any circumstance including but not limited to operational or Maintenance incidents, with a potential to affect the safety integrity of Rolling Stock, and which is identified during any Maintenance activity.
- Operational duty profiles of Rolling Stock. (including, but not limited to Tonne kilometres and total kilometres).
- Processes for the protection and validation of such systems.

In accordance with the provisions of Directive 2004/49 Annex III, the Safety Management System of the Railway Undertaking must demonstrate that suitable maintenance arrangements are in place,

**▼ B**

thereby ensuring on-going compliance with the essential requirements and the requirements of this TSI including the requirements of the Maintenance File.

In the case of entities other than the Railway Undertaking using the Rolling Stock being responsible for the maintenance of the Rolling Stock used, the Railway Undertaking using the Rolling Stock must ascertain that all relevant maintenance processes are in place and are actually applied. This must also be suitably demonstrated within the Safety Management System of the Railway Undertaking.

The entity responsible for the maintenance of the wagon shall ensure that reliable information about maintenance processes and data specified to be made available in the TSIs are available for the operating RU, and demonstrate on request of the operating RU that these processes ensure the compliance of the wagon with the Essential Requirements of Directive 2001/16/EC as modified by Directive 2004/50/EC.

#### 4.3. *FUNCTIONAL AND TECHNICAL SPECIFICATIONS OF THE INTERFACES*

##### 4.3.1. GENERAL

In the light of the essential requirements in Section 3, the functional and technical specifications of the interfaces are arranged by subsystem in the following order:

- Control and command and signalling subsystem
- Traffic operation and management subsystem
- Telematics applications for freight services subsystem
- Infrastructure subsystem
- Energy subsystem.

An additional interface has been identified with the following Council Directive:

- The Council Directive 96/49/EC and its Annex (RID)

An interface also exists with the Conventional Rail Noise TSI.

For each of these interfaces, the specifications are arranged in the same order as in Section 4.2, as follows:

- Structures and mechanical parts
- Vehicle track interaction and gauging
- Braking
- Communication
- Environmental conditions
- System protection
- Maintenance

The following list is endorsed to indicate which subsystems are identified as having an interface basic parameters of this TSI: Structures and mechanical parts (section 4.2.2):

Interface (e. g. Coupling) between vehicles, between set of Vehicles and between trains (section 4.2.2.1): *Traffic operation and management subsystem* and *Infrastructure subsystem*

Safe access and egress for rolling stock (section 4.2.2.2): *Traffic operation and management subsystem*

Strength of Main Vehicle Structure (section 4.2.2.3.1): *Infrastructure subsystem*

Service (fatigue) Loads (section 4.2.2.3.3): No interfaces identified.

**▼ B**

Stiffness of the main vehicle structure (section 4.2.2.3.4):  
No interfaces identified.

Securing of Freight (section 4.2.2.3.5): *Traffic operation and management subsystem*

Doors closing and locking (section 4.2.2.4): *No interfaces identified*

Marking of freight wagons (section 4.2.2.5): *Traffic operation and management subsystem*

Dangerous goods (section 4.2.2.6): *Traffic operation and management subsystem* and *The Council Directive 96/49/EC and its Annex RID*

*Vehicle track interaction and gauging (section 4.2.3):*

Kinematic gauge (section 4.2.3.1): *Infrastructure subsystem*

Static axle load, dynamic wheel load and linear load (section 4.2.3.2) (*Control command and signalling subsystem* and *Infrastructure subsystem*)

Rolling stock parameters, which influence ground based train monitoring systems (section 4.2.3.3): *Control command and signalling subsystem*

Vehicle dynamic behaviour (section 4.2.3.4) (*Infrastructure subsystem*)

Longitudinal compressive forces (section 4.2.3.5): *Traffic operation and management subsystem* and *Infrastructure subsystem*

*Braking (section 4.2.4):*

Braking performance section 4.2.4.1: *Control command and signalling subsystem* and *Traffic operation and management subsystem*

*Communication (section 4.2.5):*

Vehicle capability to transmit information from vehicle to vehicle (section 4.2.5.1): *Not yet applicable to freight wagons*

Vehicle capability to transmit information between ground and vehicle (section 4.2.5.2): *No interfaces identified*

*Environmental conditions (section 4.2.6)*

Environmental conditions (section 4.2.6.1): *Traffic operation and management subsystem* and *Infrastructure subsystem*

Aerodynamic effects (section 4.2.6.2): *Traffic operation and management subsystem*

Cross winds (section 4.2.6.2): *Traffic operation and management subsystem*

*System protection (section 4.2.7):*

Emergency Measures (section 4.2.7.1): *Traffic operation and management subsystem*

Fire safety (section 4.2.7.2): *Infrastructure subsystem*

Electrical protection (section 4.2.7.3): *No interfaces identified*

*Maintenance*

Maintenance file (section 4.2.8): *Traffic operation and management subsystem* and *Noise TSI*

**▼B**

## 4.3.2. CONTROL AND COMMAND AND SIGNALLING SUBSYSTEM –

4.3.2.1. *Static axle load, dynamic wheel load and linear load (section 4.2.3.2)*

Section 4.2.3.2 of this TSI specifies the minimum axle loads. The corresponding specifications are laid down in the Control and Command and Signalling TSI Annex A Appendix 1 section 3.1.

The Control and Command and Signalling TSI specifies the maximum axle distance in order to satisfy the requirement for track circuits. The corresponding specifications are laid down in the Control and Command and Signalling TSI Annex A Appendix 1 section 2.1.

4.3.2.2. *Wheels*

Wheels are specified in section 5.4.2.3. The corresponding specifications are laid down in the Control and Command and Signalling TSI section 4.2.11.

4.3.2.3. *Rolling stock parameters which influence ground based train monitoring systems*

— Hot axle box detectors (see section 4.2.3.3.2) (To be specified at the next revision of this TSI.). The corresponding specification is laid down in the Control and Command and Signalling TSI section 4.2.10.

— Electrical detection of the wheelset (section 4.2.3.3.1). Requirements for electrical detection of the wheelset are described in the Control and Command and Signalling TSI Annex A Appendix 1 section 3.5.

— Rolling Stock compatibility with Train Detection Systems

The corresponding specifications are laid down in the Control and Command and Signalling TSI section 4.2.11.

4.3.2.4. *Braking*4.3.2.4.1. *Braking performance*

The Control Command and Signalling TSI Annex A index 4 might specify the maximum number of steps of the deceleration curve (see 4.2.4.1.2.2 b)).

## 4.3.3. TRAFFIC OPERATION AND MANAGEMENT SUBSYSTEM

Interfaces to the traffic and operation management subsystem are in consideration (references to this TSI are open points).

4.3.3.1. *Interface between vehicles, between sets of vehicles and between trains*

The Traffic Operation and Management TSI or national operating rules for shunting, specify shunting speeds in accordance with the energy absorption capability of the buffers specified in section 4.2.

The Traffic Operation and Management TSI specifies the maximum train mass considering the geographical conditions in accordance with the strength of the coupler specified in section 4.2.

4.3.3.2. *Doors closing and locking*

No interface.



**▼ B****4.3.3.3. *Securing of freight***

- Loading rules are required to specify how freight wagons are to be loaded, taking account of the way the freight wagon has been designed to carry particular goods.

**4.3.3.4. *Marking of freight wagons.***

The Traffic Operation and Management TSI determines the specifications related to vehicle numbering.

**4.3.3.5. *Dangerous goods***

The traffic operation and management subsystem TSI shall specify that when freight wagons carrying dangerous goods are included in a train consist, the train configuration shall comply with the requirements of the Council Directive 96/49/EC and its Annex in their valid version.

**4.3.3.6. *Longitudinal compressive forces***

With respect to longitudinal compressive forces, the TSI Traffic and Operation Management Subsystem determines operational requirements for:

- driving trains
- drivers handling of trains including braking in various line conditions
- banking and shunting of trains due to lines and network
- coupling and handling special types of vehicles (Road-Railer™, Kombirail) in trains
- locomotives distributed in the train

**4.3.3.7. *Braking performance***

The method of calculating the deceleration profile for a new wagon is described in this TSI by using its technical vehicle parameters.

The method of calculating braking power of a train under service conditions will be described in the Traffic Operation and Management TSI.

The traffic operation and management TSI will define rules for dealing with the following subjects:

- Marshalling of trains
- Deactivating the brake, releasing the brake and selecting the brake-mode
- Communicating to the train crew and ground staff the means and conditions for parking of wagons.
- Reducing speed according to actual adhesion conditions on a line
- Making available scotches beside the tracks where it is necessary. The freight wagons shall not be required to carry scotches.
- Dealing with degraded mode, especially for short trains
- Testing the brake (operational inspection)
- Isolating the brake of a wagon with excessive deceleration rate compared to the remainder of the train.

**▼ B**4.3.3.8. **Communication**

No interface.

4.3.3.8.1. **Vehicle Capability to transmit information between ground and vehicle**

No interface.

4.3.3.9. **Environmental Conditions**

When a limit of the climactic conditions defined in section 4.2.6.1.2 of this TSI is exceeded, the system is in a degraded mode. In this case operational restrictions shall be considered and information given to the Railway Undertaking or train driver. Regarding temperature the rolling stock register and infrastructure register give the values for normal operation.

4.3.3.10. **Aerodynamic effects**

To be specified at the next revision of this TSI.

4.3.3.11. **Cross winds**

To be specified at the next revision of this TSI.

4.3.3.12. **Emergency Measures**

The Traffic Operation and Management TSI will specify that emergency arrangements and rescue plans shall be set up. The associated instructions shall include details of how to re-rail vehicles, and procedures to make damaged vehicles safe for movement. Railway undertakings shall also consider how their own staff and the staff of the civil emergency authorities are to be trained, including practical simulation exercises.

The Instructions for dealing with emergency situations shall take account of the risks to which the emergency response staff may be exposed, and give details of how those risks are to be managed. Details of risks arising from the design of the Freight Wagon and advice on how to mitigate such risks shall be given to the Railway Undertaking to enable comprehensive instructions to be written, by or on behalf of the freight wagon designer or builder.

These instructions shall also include a list of parameters that need to be checked on damaged or derailed freight wagons in a degraded situation.

4.3.3.13. **Fire Safety**

<b>Information to the drivers from the Infrastructure manager</b>	Provide rules and rescue plan for operation in case of fire.
---	--

4.3.4. **TELEMATICS APPLICATIONS FOR FREIGHT SERVICES SUBSYSTEM**

There are no interfaces between the two subsystems.

4.3.5. **INFRASTRUCTURE SUBSYSTEM**

To be specified at a later stage, once the infrastructure subsystem TSI is available.

4.3.5.1. **Interface between vehicles, between sets of vehicles and between trains**4.3.5.2. **Strength of Main Vehicle Structure and Securing of Freight**

**▼ B**

- 4.3.5.3. *Kinematic gauge*
- 4.3.5.4. *Static axle load, dynamic wheel load and linear load*
- 4.3.5.5. *Vehicle dynamic behaviour*
- 4.3.5.6. *Longitudinal compressive forces*
- 4.3.5.7. *Environmental Conditions*
- 4.3.5.8. *Fire protection*
- 4.3.6. ENERGY SUBSYSTEM  
There are no interfaces between the two subsystems.
- 4.3.7. THE COUNCIL DIRECTIVE 96/49/EC AND ITS ANNEX (RID).
- 4.3.7.1. *Dangerous goods*  
All special regulations concerning the transport of dangerous goods are fixed in the Council Directive 96/49/EC and its Annex (RID) in their valid version. All derogations, restrictions and exemptions are also listed in section II of the Council Directive 96/49/EC in its valid version.
- 4.3.8. CONVENTIONAL RAIL NOISE TSI  
To ensure ongoing adherence to the levels set in the Conventional Rail Noise TSI (see its section 4.5), wagons shall be appropriately maintained.  
The Maintenance File defined in section 4.2.8 shall include the relevant measures to deal with wheel tread defects.
- 4.4. *OPERATING RULES*  
For T<sub>RIV</sub> wagon the environmental conditions (see § 4.2.6.1 of the TSI) low temperatures (-25 °C to -40 °C) and/or conditions of snow/ice shall be taken carefully into account in the design phase of rolling stock. Even if this is done, a lower level of functionality sometimes has to be accepted and managed during operation. This shall be compensated for by the use of operational procedures to ensure the same overall safety level. It is also important that operators have the necessary qualifications or skills for operating under those conditions.
- 4.5. *MAINTENANCE RULES*  
In light of the essential requirements in Section 3, the maintenance rules specific to the rolling stock freight wagon subsystem concerned by this TSI are described in subsections:
- 4.2.2.2 Safe access and egress for rolling stock
  - 4.2.2.3 Strength of main vehicle structure and securing of freight
  - 4.2.2.4 Doors closing and locking
  - 4.2.2.6 Dangerous goods
  - 4.2.3.1 Kinematic gauge
  - 4.2.3.4 Vehicle dynamic behaviour
  - 4.2.3.4.2.3 Maintenance rules
  - 4.2.3.5 Longitudinal compressive forces
  - 4.2.5.2 Vehicle capability to transmit information between ground and vehicle
  - 4.2.7.2 Fire safety

**▼ B**

and in particular in subsection

— 4.2.8 Maintenance.

The maintenance rules shall be such as to enable the wagon to pass the assessment criteria specified in Section 6 throughout its lifetime.

The party responsible for the management of the maintenance file as defined in Section 4.2.8 shall define the tolerances and intervals appropriately to ensure ongoing compliance. It is also responsible for deciding the in-service values when not specified in this TSI.

This means the assessment procedures described in Chapter 6 of this TSI shall be fulfilled for type approval, and are not necessarily appropriate for maintenance. Not all tests may be made at every maintenance event and those that are may be subject to wider tolerances.

The combination of the above assures continuous compliance with the essential requirements through the life of the vehicle.

#### 4.6. *PROFESSIONAL QUALIFICATIONS*

The professional qualifications required for the **operation** of the Conventional Rail Rolling Stock subsystem will be covered by the TSI Traffic Operation and Management.

The competence requirements for the **maintenance** of the Conventional Rail Rolling Stock subsystem shall be detailed in the maintenance plan (see section 4.2.8). As activities related to maintenance level 1 are not in the scope of this TSI, but in the one of the TSI Traffic Operation and Management, professional qualifications associated with these activities are not specified in this TSI Rolling Stock.

#### 4.7. *HEALTH AND SAFETY CONDITIONS*

Apart from requirements specified in the maintenance plan (see section 4.2.8) in this TSI, there are no additional requirements to applicable European regulations and existing national regulations compatible with European ones on health and safety for maintenance or operations staff.

Activities related to maintenance level 1 are not in the scope of this TSI, but in the TSI Traffic Operation and Management. Health and safety conditions at work associated with these activities are not specified in this TSI Rolling Stock.

#### 4.8. *INFRASTRUCTURE AND ROLLING STOCK REGISTERS*

##### 4.8.1. INFRASTRUCTURE REGISTER

The Infrastructure Register shall contain the following mandatory data as listed in Annex KK.

The requirements for the conventional rail infrastructure register content with regard to the subsystem Rolling Stock are specified in subsection 4.2.6.1 (environmental conditions). The infrastructure manager is responsible for the correctness of the data provided for inclusion in the infrastructure register.

##### 4.8.2. ROLLING STOCK REGISTER

The Rolling Stock Register shall contain the following mandatory data for all freight wagons, which are in accordance with this TSI as listed in Annex H.

If the Member State of registration changes, the contents of the Rolling Stock Register for that wagon shall be passed from the original State of registration to the new State of registration.

**▼ B**

The data contained in the Rolling Stock Register is required by:

- The Member State to confirm that the freight wagon meets the requirements in accordance with this TSI
- The Infrastructure Manager to confirm that the freight wagon is compatible with the infrastructure over which it is intended to operate
- The Railway Undertaking to confirm that the freight wagon is suitable for its traffic requirements.

In the territory of all Member States, the requirements applicable in neighbouring third countries are applied to freight wagons arriving from or going to these third countries, subject to the additional requirements which define minimum criteria of the interfaces between the freight wagons and the infrastructure and the interfaces of these freight wagons to locomotives.

Where the data which is available concerning these freight wagons is less than required for the Rolling Stock Register, the Railway Undertaking shall put in place arrangements to ensure that the vehicles are safe to operate on the TSI-compliant infrastructure.

## 5. INTEROPERABILITY CONSTITUENTS

### 5.1. DEFINITION

According to Article 2(d) of Directive 2001/16/EC:

Interoperability constituents are ‘any elementary component, group of components, subassembly or complete assembly of equipment incorporated or intended to be incorporated into a subsystem upon which the interoperability of the trans-European conventional rail system depends directly or indirectly. The concept of a constituent covers both tangible objects and intangible objects such as software’.

Interoperability constituents described in section 5.3 are constituents, whose technology, design, material, manufacturing and assessment processes are defined and enable their specification and assessment.

### 5.2. INNOVATIVE SOLUTIONS

As announced in section 4.1 of this TSI, innovative solutions may require new specification and/or new assessment methods. These specifications and assessment methods shall be developed by the process described in sections 6.1.2.3 (and 6.2.2.2).

### 5.3. LIST OF CONSTITUENTS

The interoperability constituents are covered by the relevant provisions of Directive 2001/16/EC and are listed below.

#### 5.3.1. STRUCTURES AND MECHANICAL PARTS

##### 5.3.1.1. *Buffers*

##### 5.3.1.2. *Draw gear*

##### 5.3.1.3. *Decals for Markings*

#### 5.3.2. VEHICLE TRACK INTERACTION AND GAUGING

##### 5.3.2.1. *Bogie and Running Gear*

##### 5.3.2.2. *Wheelsets*

##### 5.3.2.3. *Wheels*

##### 5.3.2.4. *Axles*

#### 5.3.3. BRAKING

##### 5.3.3.1. *Distributor*

##### 5.3.3.2. *Relay valve for variable load/Automatic empty-load change over brake*

**▼ B**

- 5.3.3.3. *Wheel slide protection device*
- 5.3.3.4. *Slack adjuster*
- 5.3.3.5. *Brake cylinder/actuator*
- 5.3.3.6. *Pneumatic half coupling*
- 5.3.3.7. *End Cock*
- 5.3.3.8. *Isolating device for distributor*
- 5.3.3.9. *Brake pad*
- 5.3.3.10. *Brake blocks*
- 5.3.3.11. *Brake Pipe Emptying Accelerator valve*
- 5.3.3.12. *Automatic load sensing & empty/load changeover device*
- 5.3.4. COMMUNICATION
- 5.3.5. ENVIRONMENTAL CONDITIONS
- 5.3.6. SYSTEM PROTECTION
  
- 5.4. *CONSTITUENTS PERFORMANCES AND SPECIFICATIONS*
  
- 5.4.1. STRUCTURES AND MECHANICAL PARTS
  
- 5.4.1.1. *Buffers*

The specifications of the interoperability constituent buffers are described in section 4.2.2.1.2.1 buffers, paragraph ‘buffer characteristics’.

The interfaces of the interoperability constituents ‘buffers’ are described in 4.3.3.1 for traffic operation and management and in 4.3.5.1 for infrastructure.
- 5.4.1.2. *Draw Gear*

The specifications of the interoperability constituent draw gear are described in section 4.2.2.1.2.2 draw gear, paragraph ‘draw gear characteristics’ and section 4.2.2.1.2.3 interaction of draw- and buffing-gear, paragraph ‘draw gear and buffing gear characteristics’.

The interfaces of the interoperability constituents draw gear are described in 4.3.3.1 for traffic operation and management and in 4.3.5.1 for infrastructure.
- 5.4.1.3. *Decals for Markings*

Where markings are achieved by using decals, these are Interoperability Constituents. These markings are specified in Annex B
- 5.4.2. VEHICLE TRACK INTERACTION AND GAUGING
- 5.4.2.1. *Bogie and Running Gear*

The integrity of the structure of the bogie and running gear is important for the safe operation of the railway system.

The loading environment of the bogie and running gear is determined by

  - the maximum speed
  - static track features (alignment, track gauge, cant, rail inclination, track irregularities)

**▼ B**

- dynamic track features (horizontal and vertical track stiffness and track damping)
- wheel/rail contact parameters (Wheel and rail profile, track gauge)
- wheel defects (e.g. wheel flats, out of roundness)
- mass, inertia and stiffness of car body, bogies and wheelsets
- suspension characteristic of the vehicles
- distribution of the payload
- braking performance.

The specifications of the interoperability constituents bogie and running gear are described in 4.2.3.4.1, 4.2.3.4.2.1 and 4.2.3.4.2.2 Vehicle Track Interaction and Gauging.

It is permissible for bogies to be used in other application without further validation (testing) provided the range of applicable parameters in the new application (including those of the vehicle body) remain within the range already proved.

In order to ensure safe operation of the bogies and running gear, they shall be designed to withstand the loading environment expected during their operation. In particular, the bogies and running gear shall be compliant with the test conditions detailed in section 6.

The list containing bogie designs that at the time of publication are already considered to meet the requirements of this TSI for some applications is attached in Annex Y.

The Interfaces of the interoperability constituent bogie and running gear with the subsystem Control and Command and Signalling relative to the spacing of the axles are described in 4.3.2.1 Static axle load, dynamic wheel load and linear load.

Freight wagons shall be designed such that operating through curves, on ramps and with access on ferry boats is possible without contact between bogies and car body. The side bearers of the bogie wagons shall have sufficient overlap in the smallest curve radius for which the wagon has been designed. If the wagon is only capable of operating on a smaller ferry boat angle than 2,5 degrees, then the marking according to Annex B, Fig. B 25, shall be applied. If the wagon is only capable of operating on a bigger curve radius than 35 m, then the marking according to Annex B, Fig. B 24, shall be applied.

#### 5.4.2.2. **Wheelsets**

Track Interaction and Gauging 4.2.4.1.2.5 Braking and 4.2.7.3.2.1 System protection.

The detailed specification is described in section 4.2.3.3.1 Electrical resistance, in section 4.2.4.1.2.5 energy limits (in braking) in Annex K and in Annex E, which includes example solutions in some elements.

A complete functional specification of the IC wheelset is deferred until the next revision of this TSI

The Interfaces of the interoperability constituent wheelset with the subsystem Control and Command and Signalling are described in 4.3.2.1 Static axle load, dynamic wheel load and linear load.

#### 5.4.2.3. **Wheels**

The detailed specification is described in Annex L, which includes example solutions in some elements and Annex E.

A complete functional specification of the IC wheel is deferred until the next revision of this TSI.

**▼ B**

The Interfaces of the interoperability constituent wheel with the subsystem Control and Command and Signalling are described in 4.3.2.1 Static axle load, dynamic wheel load and linear load.

5.4.2.4. ***Axles***

The detailed specification is described in Annex M, which includes example solutions in some elements.

A complete functional specification of the IC axles is deferred until the next revision of this TSI.

The Interfaces of the interoperability constituent axle wheelset with the subsystem Control and Command and Signalling are described in 4.3.2.1 Static axle load, dynamic wheel load and linear load.

## 5.4.3. BRAKING

5.4.3.1. ***Constituents approved at the time of publication of this TSI***

The list containing brake system and brake constituent designs that at the time of publication are already considered to meet the requirements of this TSI for some applications is attached in Annex FF.

5.4.3.2. ***Distributor***

The functional specification of the interoperability constituent distributor is described in 4.2.4.1.2.2 Braking Performance Elements and 4.2.4.1.2.7 Air Supply.

The interfaces of the interoperability constituent are described in Annex I section I.1.

5.4.3.3. ***Relay valve for variable load/Automatic empty-load change over brake***

The functional specification of the interoperability constituent relay valve for variable load/Automatic empty/load changeover brake is described in 4.2.4.1.2.2 Braking Performance Elements and 4.2.4.1.2.7 Air Supply.

The interfaces of the interoperability constituent ~~is~~ are described in Annex I section I.2.

5.4.3.4. ***Wheel slide protection device***

The functional specification of the interoperability constituent wheel slide protection device is described in 4.2.4.1.2.6 wheel slide protection and 4.2.4.1.2.7 Air Supply.

The specification of the interoperability constituent is described in Annex I section I.3.

5.4.3.5. ***Slack adjuster***

The functional specification of the interoperability constituent slack adjuster is described in 4.2.4.1.2.3 Mechanical Components.

The specification of the interoperability constituent is described in Annex I section I.4.

5.4.3.6. ***Brake cylinder/actuator***

The functional specification of the interoperability constituent brake cylinder/actuator is described in 4.2.4.1.2.2 Braking



**▼B**

Performance Elements, 4.2.4.1.2.8 Parking Brake, 4.2.4.1.2.5 Energy Limits and 4.2.4.1.2.7 Air Supply.

The specification of the interoperability constituent is described in Annex I section I.5.

5.4.3.7. ***Pneumatic half coupling***

The specification of the interoperability constituent is described in Annex I section I.6.

5.4.3.8. ***End Cock***

The specification of the interoperability constituent is described in Annex I section I.7

5.4.3.9. ***Isolating device for distributor***

The specification of the interoperability constituent is described in Annex I section I.8

5.4.3.10. ***Brake pad***

The specification of the interoperability constituent is described in Annex I section I.9

5.4.3.11. ***Brake blocks***

The specification of the interoperability constituent is described in Annex I section I.10

5.4.3.12. ***Brake Pipe Emptying Accelerator valve***

The specification of the interoperability constituent is described in Annex I section I.11

5.4.3.13. ***Automatic load sensing & empty/load changeover device***

The specification of the interoperability constituent is described in Annex I section I.12

6. **ASSESSMENT OF CONFORMITY AND/OR SUITABILITY FOR USE OF THE CONSTITUENTS AND VERIFICATION OF THE SUBSYSTEM**

6.1. ***INTEROPERABILITY CONSTITUENTS***

6.1.1. **ASSESSMENT PROCEDURES**

The assessment procedure for conformity or suitability for use of interoperability constituents shall be based on European specifications or specifications approved in accordance with Directive 2001/16/EC.

In the case of suitability for use, these specifications will indicate all the parameters to be measured, monitored or observed, and will describe the related testing methods and measuring procedures, whether in a test-bench simulation or tests in a real railway environment.

The manufacturer of an Interoperability Constituent (IC) or his authorised representative established within the Community shall draw up an EC declaration of conformity or an EC declaration of suitability for use in accordance with Article 13.1 and Annex IV of the Directive 2001/16/EC before placing ICs on the market.

**▼ B**

The assessment procedures for conformity of ICs defined in Section 5 of this TSI shall be carried out by application of modules as specified in Section 6.1.2

Assessment of conformity or suitability for use of an IC shall be carried out by a notified body, when indicated in the procedure, with which the manufacturer or its authorised representative in the Community has lodged the application

The modules shall be combined and used selectively according to the particular constituent.

The modules are defined in Annex Q of this TSI.

The phases for the application of the conformity and suitability for use assessment procedures for the interoperability constituents as defined in Section 5 of this TSI are indicated in Annex Q, Table Q.1 to this TSI.

## 6.1.2. MODULES

### 6.1.2.1. *General*

For the conformity assessment procedure of interoperability constituents within the rolling stock subsystem, the manufacturer or his authorised representative established within the Community may choose:

- a) the type-examination procedure (module B) for the design and development phase in combination with a module for the production phase: either the production quality management system procedure (module D), or the product verification procedure (module F),

or alternatively

- b) the full quality management system with design examination procedure (module H2) for all phases,

or

- c) the full quality management system procedure (module H1)

Module D may only be chosen where the manufacturer operates a quality system for production, final product inspection and testing approved and surveyed by a notified body of its choice. Assessment of welding processes shall be carried out according to national rules.

Module H1 or H2 may only be chosen where the manufacturer operates a quality system for design, production, final product inspection and testing, approved and surveyed by a notified body of its choice.

The conformity assessment shall cover the phases and characteristics as indicated by 'X' in the Table Q1 of Annex Q to this TSI.

### 6.1.2.2. *Existing solutions for Interoperability Constituents*

If a existing solution for an interoperability constituent is already on the European market before this TSI enters into force, then the following process applies.

The manufacturer shall demonstrate that tests and verification of ICs have been considered successful for previous applications under comparable conditions. In this case these assessments shall remain valid in the new application.

In this case, the type can be considered as already approved and an assessment of the type is not necessary.

In accordance with assessment procedures for the different ICs, the manufacturer or its authorised representative established within the Community shall:

**▼ B**

- either apply the internal production control procedure (module A),
- or apply the internal design control with production verification procedure (module A1),
- or apply the full quality management system procedure (module H1).

If it is not possible to demonstrate that the solution is positively proven in the past, the Section 6.1.2.1 applies.

#### 6.1.2.3. *Innovative solutions for Interoperability Constituents*

When a solution proposed to be an Interoperability Constituent is innovative, as defined in the section 5.2, the manufacturer shall state the deviation from the relevant section of the TSI. The European Railway Agency shall finalise the appropriate functional and interface specifications of the constituents and develop the assessment methods.

The appropriate functional and interface specifications and the assessment methods shall be incorporated in the TSI by the revision process. As soon as these documents are published, the assessment procedure of the interoperability constituents may be chosen by the manufacturer or his authorised representative established within the Community, as specified in the section 6.1.2.1

After entry into force of a decision of the Commission, taken in accordance with Article 21(2) of Directive 2001/16/EC, the innovative solution may be used before being incorporated into the TSI.

#### 6.1.2.4. *Assessment of suitability for use*

Whenever an assessment procedure is started based on in-service experience for an interoperability constituent within the rolling stock subsystem, the manufacturer or his authorised representative established within the Community shall apply the type validation of in service experience procedure (module V).

### 6.1.3. SPECIFICATION FOR ASSESSMENT OF ICS

#### 6.1.3.1. *Structures and mechanical parts*

##### 6.1.3.1.1. **Buffers**

The buffers are to be assessed against the specification contained in section 4.2.2.1.2.1 buffers paragraph buffer characteristics.

##### 6.1.3.1.2. **Draw Gear**

The draw gear shall be assessed against the specification contained in section 4.2.2.1.2.2 draw gear, paragraph 'draw gear characteristics' and section 4.2.2.1.2.3 interaction of draw- and buffing-gear, paragraph 'draw gear and buffing gear characteristics'.

##### 6.1.3.1.3. **Marking of Freight Wagons**

The decals for marking are to be assessed against the specification contained in Annex B

#### 6.1.3.2. *Vehicle track interaction and gauging*

##### 6.1.3.2.1. **Bogie and Running Gear**

The integrity of the structure of the body to bogie connection, bogie frame, axle-box and all attached equipment shall be assured. This assurance shall be generated by use of sufficient appropriate methods, such as demonstration by bench tests, validated modelling, comparison with an existing design

**▼ B**

approved by or on behalf of national approval regime, which is used in similar service and condition or other methods.

The test conditions applicable for bogies running on standard gauge track under normal conditions of speed and track quality are defined in Annex J. They represent only the common part of the full range of tests to be performed on all types of bogie frames.

It is not possible to specify tests of a general nature for each specific bogie component, in particular for the axle bearings, the connection between bogie and body, the dampers and the brakes. Such tests shall be drawn up case by case, using the tests defined above as a guide. The objectives and the parameter definitions of the tests already specified are detailed below.

This remark also applies to the case of bogie frames intended for service on track with a different gauge, or under clearly different operating conditions, or bogies with a novel design.

The three tests described in Annex J Sections J1, J2 and J3 have been defined in order to:

- optimise the construction of the bogie frame (weight, speed)
- supplement the information obtained from calculations
- ensure that the bogie frames are suitable for withstanding the in-service loads without the occurrence of permanent deformation or cracks that would reduce safety or result in high maintenance costs.

If there is no comparable solution available, experience has shown that three tests are required: two static tests (Annex J sections J1 and J2), and one dynamic test (Annex J section J3).

The two static tests shall be performed first; they allow, in particular, for any bogies that do not meet the minimum strength requirements to be rejected.

The dynamic test (fatigue test) is designed to verify whether the bogie design is sound, and whether fatigue cracks might be expected to occur in service.

The load values that have been used for the definition of the tests have been derived in particular from running tests.

The tests in Annex J section J1 are considered to represent the maximum loads that can occur in service, without taking the loads due to accidents into account.

The tests in Annex J sections J2 and J3 are considered to represent, on average, the aggregate total of variable loads occurring during the bogie service life.

The number of cycles in the fatigue test was selected to simulate an overall service life of 30 years at a rate of 100 000 km per year. If this is not representative of the intended life cycle, the load cases shall be revised.

The distribution of these cycles over three distinct load stages was done with a view to optimising bogie frame structures. In particular, the possibility of the occurrence of cracks during the last load stage provides a means to identify the most highly stressed zones, to which special attention shall be paid during manufacture, production testing and maintenance operations.

To ensure the validity of the tests defined in Annex J sections J1, J2 and J3, particular attention shall be paid to their practical implementation. In particular: -

For the static tests of Annex J sections J1 and J2, the bogie frames shall be equipped with uni-directional strain gauges in those locations where stresses occur with a single clearly defined direction; in all other locations tri-directional strain gauges (rosettes) shall be used.

The active part of these gauges shall not exceed 10 mm.

**▼ B**

Strain gauges and strain rosettes are attached to the bogie frame at all highly stressed points, in particular in zones of stress concentration.

The test set-up shall be defined so as to reproduce the forces acting on the bogie frame, and its deformation, as they occur in service. Particular attention shall be paid to the transmission of the vertical and transverse loads that in certain cases are distributed over several elements (e.g. pivot, springs, stops...).

The static tests shall be performed on a complete bogie, equipped with its suspension. In most cases, this arrangement is not feasible for the fatigue test for practical reasons; a separate study shall be conducted to define the test set-up.

The bogie frames used for the three tests shall be complete, and equipped with all their connecting elements (for dampers, brakes, etc.). They shall conform fully to the production drawings, and they shall have been manufactured under the same conditions as series-produced bogie frames.

If cracks or fractures occur during the fatigue test, originating from manufacturing defects that were not detected during the preceding static testing of the bogie frame, the test shall be repeated with another frame. If the defects are confirmed, the design shall be considered as unsatisfactory.

6.1.3.2.2. **Wheelsets**

The assessment of the wheelset is described in Annex K.

6.1.3.2.3. **Wheels**

The assessment of the design and of the product is described in Annex L.

6.1.3.2.4. **Axle**

The assessment of the design and of the product is described in Annex M.

6.1.3.3. **Braking**

See Annex P.

6.2. **SUBSYSTEM CONVENTIONAL RAIL ROLLING STOCK FREIGHT WAGONS**

6.2.1. **ASSESSMENT PROCEDURES**

At the request of the contracting entity or its representative established in the Community, the notified body carries out EC verification in accordance with annex VI of the Directive 2001/16/EC.

If the contracting entity can demonstrate that tests or verifications related to the Conventional Rail Rolling Stock Subsystem have been considered successfully for any previous application, these assessments shall be taken into account in the conformity assessment.

Modified freight wagons changed within the limits given in Annex II shall not require a new conformity assessment.

The impact of weight change on safety critical components, safety related components, the interaction between infrastructure and the freight wagon, and on classification for line categories according to 4.2.3.2, must in all cases be considered.

As far as specified in this TSI, the EC verification of the Conventional Rail Rolling Stock Subsystem shall take into account its interfaces with other subsystems of the Conventional Rail System.

The contracting entity shall draw up the EC declaration of verification for the Rolling Stock Subsystem in accordance with Article 18 (1) and Annex V of Directive 2001/16/EC.

**▼ B**

## 6.2.2. MODULES

6.2.2.1. *General*

The Modules to choose for the verification procedures are defined in Annex AA.

For the verification procedure of the requirements of Freight wagons, as specified in section 4, the contracting entity or its authorised representative established within the Community may choose the following modules:

- a) the Type Examination procedure (module SB) for the design and development phase, in combination with a module for the production phase either:
  - the Production Quality Management System procedure (module SD),
  - or the Product Verification (module SF);

or

- b) the Full quality Management System with Design Examination procedure (module SH2).

The module SD may only be chosen where the contracting entity, or the main contractors when involved, operate a quality management system for manufacture, final production inspection and testing, approved and surveyed by a Notified Body of his/their choice. Assessment of welding processes shall be carried out according to national rules.

The module SH2 may only be chosen where the contracting entity, or the main contractors when involved, operate a quality management system for design, manufacture, final production inspection and testing, approved and surveyed by a Notified Body of his/their choice.

The following additional requirements shall be taken into account for the use of the modules:

- Module SB: with reference to section 4.3 of the module, a design review is requested,
- For the production phase, modules SD, SF and SH2: the application of these Modules shall enable the conformity of the wagons with the approved type as described in the type examination certificate. In particular, the application shall demonstrate that the manufacture and the assembly are realised with the same components and the same technical solutions as the approved type.

6.2.2.2. *Innovative solutions*

When a freight wagon includes an innovative solution, as defined in section 4.1, the manufacturer or the contracting entity shall state the deviation from the relevant section of the TSI.

The European Railway Agency shall finalise the appropriate functional and interface specifications of this solution and develop the assessment methods.

The appropriate functional and interface specifications and assessment methods shall be incorporated in the TSI by the revision process. As soon as these documents are published, the assessment procedure for the freight wagon may be chosen by the manufacturer or the contracting entity or his authorised representative established within the Community, as specified in the section. 6.2.2.1.

After entry into force of a decision of the Commission, taken in accordance with Article 21(2) of Directive 2001/16/EC, the innovative solution may be used before being incorporated into the TSI.

**▼B**6.2.2.3. ***Assessment of Maintenance***

According to article 18.3 of the Directive 2001/16/EC, the Notified Body shall compile the Technical File, which includes the Maintenance File.

The conformity assessment of maintenance is in the responsibility of each member state concerned. The Annex DD (which remains an open point) describes the procedure by which each member state ascertains that maintenance arrangements meet the provisions of this TSI and ensure the respect of the basic parameters and essential requirements during the subsystem lifetime.

## 6.2.3. SPECIFICATIONS FOR ASSESSMENT OF THE SUBSYSTEM

6.2.3.1. ***Structures and Mechanical Parts***6.2.3.1.1. **Strength of main vehicle structure and Securing of Freight**

Validation of the design shall follow the requirements of Section 6 of EN12663.

The test programme shall include a shunting impact test as defined in Annex Z if no demonstration of structural integrity by calculation has been performed.

Where tests have previously been carried out on similar components or sub-systems it is not necessary to repeat the tests, provided a clear safety justification showing the applicability of the earlier tests can be provided.

6.2.3.2. ***Vehicle track interaction and gauging***6.2.3.2.1. **Vehicle dynamic behaviour**6.2.3.2.1.1. *Application of the partial type approval procedure*

When a wagon has already been type approved, modifications of certain of its characteristics (see section 4.2.3.4.1) or of the conditions of its operation that affect its dynamic behaviour may require an additional test.

6.2.3.2.1.2. *Certification of new wagons*

When new wagons have to be approved by commissioning tests, these tests shall be done by:

1) measurement of wheel/rail forces

or

2) measurement of accelerations

or

3) validated modelling

or

4) comparison with existing vehicles

The precise limit values will vary according to the testing and analysis method used.

6.2.3.2.1.3. *Exemptions from dynamic behaviour test for wagons to built or converted to run up to 100km/h or 120km/h*

Freight wagons are permitted to run up to 100km/h or 120km/h without having to pass the dynamic behaviour test if they meet the following conditions defined in

— Longitudinal Compression Forces 4.2.3.5

— Static axle load, dynamic wheel load and linear load 4.2.3.2

and if they are fitted with a suspension or bogie listed below.

**▼B****Two axle wagons**

Freight wagons shall be fitted with type of suspensions listed in Annex Y in the table relating to two axle wagons.

**Wagons with two-axle bogies**

The freight wagons shall be fitted with types of bogies or variants provided that the modifications with respect to the basic type only affect elements that cannot influence the dynamic behaviour. These bogies are listed in Annex Yin the two tables relating to wagons with two axle bogies.

**Wagons with three-axle bogies**

The freight wagons shall be fitted with types of bogies or variants provided that the modifications with respect to the basic type only affect elements, which cannot influence the dynamic behaviour. These bogies are listed in Annex Yin the table relating to wagons with three axle bogies.

**▼M1**6.2.3.2.1.4. *Exemptions from stationary tests*

Freight wagons are exempted from the stationary tests mentioned in section 4.2.3.4.2.1 if they comply with the requirements of UIC leaflet 530-2 (May 2006).

**▼B**6.2.3.2.2. **Longitudinal compressive forces for freight wagons with side buffers**

When it is necessary to require the certification of the admissible longitudinal compressive force by tests, then the tests have to be carried out according to the method described in Annex R, at least with the measurement areas given in this Annex.

6.2.3.2.3. **Measuring the freight wagons**

Evidence shall be provided by measuring the freight wagon under-frames and bogies that deviations from the nominal dimensions are within the permissible tolerances (EN 13775 part 1 to 3 and prEN 13775 parts 4 to 6).

6.2.3.3. **Braking**6.2.3.3.1. **Braking performance**

The methods to determine the braking power are described in Annex S.

6.2.3.3.2. **Minimum Brake System Testing**

The tests and limits below apply to wagons fitted with conventional air brakes for freight trains.

These tests shall be performed only with the single pipe mode (the Brake Pipe). Tests with the auxiliary reservoir filled permanently from the Main Reservoir Pipe shall also to be carried out to demonstrate that the brake operation is not adversely affected.

The normal working pressure (regime pressure) of the conventional air brake is 5 bar. These tests shall be performed at this pressure. Additionally sample tests shall be performed to ensure that the operation of the brake is not adversely affected, with a decrease or an increase in this working pressure not exceeding 1 bar.

The tests shall be performed in the 'P' and 'G' brake modes, when fitted. Where variable or empty load braking systems are fitted, the tests shall be carried out in the 'loaded' and 'empty' positions to ensure that the operation of the brake is not adversely affected and is compliant with this TSI.

The use of electricity or other means to control the brake is permitted provided the principles of this TSI are retained. The equivalent level of safety shall be demonstrated.





Tests listed in the table below are done based on a separate vehicle when stationary or on a stationary train.

Individual Interoperability Constituents have their design and product assessment described within Annex P.

Pneumatic Brake Characteristics		
No	Characteristic	Limit Value
1	Fill time of the brake cylinder to 95 % maximum pressure	<i>P Setting</i> 3-5 seconds (3-6 seconds in the case of an empty/load system) <i>G Setting</i> 18-30 seconds
2	Release time of the brake cylinder to 0,4 bar pressure	<i>P Setting</i> 15-20 seconds For a total weight of 70 tonnes or greater, it is permissible for the release time to be 15 to 25 seconds. <i>G Setting</i> 45-60 seconds In the case of brakes with pneumatically-controlled devices for the variation of the braking power, the release time is the time which must elapse before a pressure of 0,4 bar is seen in the relay control chamber (pilot pressure)
3	Reduction in brake pipe pressure required to obtain maximum brake cylinder pressure	1,5 ± 0,1 bar
4	Maximum brake cylinder pressure	3,8 ± 0,1 bar
5	Sensitivity/Insensitivity The insensitivity of the brake to slow decreases in brake pipe pressure, shall be such that the brake is not activated if the normal working pressure drops by 0,3 bar in one minute. The sensitivity of the brake to decreases in brake pipe pressure shall be such that the brake is activated within 1,2 seconds if the normal working pressure drops by 0,6 bar in 6 seconds.	Brake does not activate with a 0,3 bar drop in one minute. Brake activates within 1,2 seconds with a 0,6 bar drop in 6 seconds.
6	Brake pipe leakage from a starting pressure of 5 bar	0,2 bar maximum pressure loss in 5 minutes
7	Brake cylinder, auxiliary reservoir and control reservoir leakage from a starting Brake Cylinder pressure of 3,8 + or — 0,1 bar from a brake pipe pressure of 0 bar	0,15 bar maximum pressure loss in 5 minutes measured at the auxiliary reservoir.
8	Manual release of the automatic air brake.	Brake releases
9	Graduability in application and release variations in brake pipe pressure:	Less or equal to 0,1 bar.
10	Pressure corresponding to the return to the filling position at the time of brake release	Brake Pipe: - 0,15 bar below actual running pressure Brake cylinder: < 0,3 bar
11	Automatic air brake indicator	Ensure the indicator reflects the brake state — applied or released
12	Slack adjuster to be tested by creating an excessive brake friction pair gap and demonstrating that repeated application/release cycles restore correct clearance	Design brake friction pair pad/block clearance
13	Compliance to design brake pad/block loads	Brake pad/block loads shall comply with design



Pneumatic Brake Characteristics		
No	Characteristic	Limit Value
14	Brake rigging shall be free to move and allow brake pads/blocks to clear the brake discs/wheels in the released state and not reduce application forces below design	Brake rigging shall be free
15	Parking brake components shall be free moving and lubricated if required	Free movement: ensure that it applies and releases without binding.
16	Control and Performance of the parking brake shall be such that with 500 N force applied to the end of a brake lever or tangentially to a hand wheel rim, the parking brake is fully applied.	500 N input force
17	Manual release of the parking brake	Parking Brake releases
18	Parking brake indicator shall reflect state of brake	Indicator shall accurately show the brake state — applied or released

## Notes on Table above:

- N1. The timings shall be obtained from an emergency application on a single vehicle. Following inshot to approximately 10 % of the final brake cylinder pressure, the increase in pressure shall be progressive. The filling time begins when air commences to fill the cylinder and ends when the pressure reaches 95 % of the final value, and shall be as stated.
- N2. At the time of full and continuous release of the brake on a separate vehicle following an emergency application, the pressure in the brake cylinder shall fall progressively. The release time, measured from when air commences to be exhausted from the cylinder, to when the pressure reaches 0,4 bar shall be as stated.
- N3. In order to obtain maximum brake cylinder pressure, the brake pipe pressure shall be reduced by 1,4 to 1,6 bar below the regime pressure.
- N4. The maximum brake cylinder pressure obtained from a reduction in brake pipe pressure of 1,4 to 1,6 bar shall be 3,7 to 3,9 bar.
- N5. The insensitivity of the brake to slow decreases in brake pipe pressure, shall be such that the brake is not activated if the normal working pressure drops by 0,3 bar in one minute.
- The sensitivity of the brake to decreases in brake pipe pressure shall be such that the brake is activated within 1,2 seconds if the normal working pressure drops by 0,6 bar in 6 seconds.
- N6. After charging the brake pipe to 5 bar, isolate the brake pipe, allow time for settlement and then ensure leakage does not exceed that stated.
- N7. After an emergency braking, with a brake pipe pressure of 0 bar, start measuring after the stabilisation period and ensure overall leakage does not exceed that stated.
- N8. The brake shall have a device enabling manual brake release.
- N9. The brake shall be such that the pressure in the brake cylinder continuously follows the variations in the brake pipe pressure. A pressure variation of +/- 0,1 bar in the brake pipe shall cause the distributor to change the brake cylinder pressure correspondingly.

**▼B**

For one value of brake pipe pressure, the brake cylinder pressure shall not vary by more than 0,1 bar during application and release. (For braking via pneumatically controlled relay valves for braking power variation, the 0,1 bar value applies to the pilot pressure.)

- N10. In the case of brakes with relay valves for the variation of the braking power, the pressure of 0,3 bar corresponds to the pressure existing at the pneumatic relay control (pilot reservoir).
- N11. Wagons where the automatic air brake application/release state cannot be checked without going underneath the wagon (for example those fitted with axle mounted disc brakes) shall be fitted with an indicator showing the state of the automatic brake.
- N12. Correct slack adjuster operation shall be confirmed by creating an excessive brake friction pair gap, demonstrating that repeated application/release cycles restore the correct clearance.
- N13. On the first of a series of wagons, the brake pad or block application force shall be measured to confirm that it complies with the design.
- N14. Brake rigging shall be free such that the pads/blocks clear the brake discs/wheels in the released state, and application forces are not reduced below design.
- N15. Parking brake components, rigging, leadscrews & nuts etc, shall be free moving and lubricated if required by the design.
- N16. On the first of a series of wagons, the vehicle retarding force shall be measured resulting from a 500N input force at the end of a parking brake lever, or applied tangentially to a handwheel rim. The force measured shall comply with the design.
- N17. The parking brake shall be applied and released manually, not adversely affecting the friction pair gap in the released state.
- N18. A parking brake indicator shall be fitted which accurately reflects the status of the parking brake, applied or released.

The tests procedures shall conform to the European standards.

For freight wagons equipped with 'R' braking mode specific tests shall be done. These tests shall conform to the European standards.

#### 6.2.3.4. *Environmental conditions*

##### 6.2.3.4.1. **Temperature and other environmental conditions**

###### 6.2.3.4.1.1. *Temperature*

All components and groups of components have to be tested in accordance with requirements given in section 4.2 and 6 and referenced European Standards, taken into account which temperature class specified in section 4.2.6.1.2.2 the wagon shall be approved for.

###### 6.2.3.4.1.2. *Other environmental conditions*

It is sufficient for the supplier to make a declaration of conformity stating how the environmental conditions in the following sections have been taken into account in the design of the wagon:

4.2.6.1.2.1 (Altitude)

4.2.6.1.2.3 (Humidity)

4.2.6.1.2.5 (Rain)

4.2.6.1.2.6 (Snow, ice and hail)

**▼B**

4.2.6.1.2.7 (Solar radiation)

4.2.6.1.2.8 (Resistance to pollution)

The Notified Body shall verify that this declaration exists and that the content is reasonable.

This does not affect specific test requirements regarding environmental conditions given in section 4 or 6. They shall be executed and verified. Those tests shall be referenced in the declaration.

6.2.3.4.2. **Aerodynamic effects**

Open point to be specified at the next revision of this TSI.

6.2.3.4.3. **Cross winds**

Open point to be specified at the next revision of this TSI.

7. **IMPLEMENTATION**

7.1. *GENERAL*

The implementation of the TSIs must take into consideration the overall migration of the conventional rail network towards full interoperability.

In order to support this migration, the TSIs allow for staged, gradual application and co-ordinated implementation with other TSIs.

In the case of this TSI it shall be implemented in close co-ordination with the Noise TSI.

7.2. *TSI REVISION*

In conformity with article 6(3) of Directive 2001/16/EC as modified by Directive 2004/50/EC, the Agency shall be responsible for preparing the review and updating of TSIs and making appropriate recommendations to the Committee referred to in Article 21 of this directive in order to take account of developments in technology or social requirements. In addition, the progressive adoption and revision of other TSIs may also impact this TSI. Proposed changes to this TSI shall be subject to rigorous review and updated TSIs will be published on an indicative periodic basis of 3 years.

The Agency shall be notified of any innovative solutions under consideration in order to determine its future inclusion within the TSI.

7.3. *APPLICATION OF THIS TSI TO NEW ROLLING STOCK*

Sections 2 to 6 and any specific provisions in paragraph 7.7 below apply in full to new freight wagons being placed into service, with the following exceptions:

- the provisions of section 4.2.4.1.2.2 (Braking Performance elements) deceleration profile in braking power, for which a date of implementation will be given in future revisions of the TSI.

This TSI does not apply to wagons being subject to a contract already signed or under final phase of tendering procedure before the date of entry into force of this TSI.

7.4. *EXISTING ROLLING STOCK*

7.4.1. **APPLICATION OF THIS TSI TO EXISTING ROLLING STOCK**

Existing freight wagons are freight wagons that are already in service before this TSI enters into force.

**▼B**

The TSI does not apply to existing rolling stock as long as it is not renewed or upgraded.

7.4.2. UPGRADING AND RENEWAL OF EXISTING FREIGHT WAGONS

Upgraded or renewed freight wagons requiring new authorisation for placing into service within the meaning of Directive 2001/16/EC Article 14.3, shall comply with:

— sections 4.2, 5.3, 6.1.1 and 6.2 and any specific provisions in paragraph 7.7 below, as soon as this TSI comes into force and

The following exceptions shall apply:

- 4.2.3.3.2 Hot axle box detection (To be specified at the next revision of this TSI);
- 4.2.4.1.2.2 Deceleration profile in braking power;
- 4.2.6 Environmental conditions;
- 4.2.6.2 Aerodynamic effects (To be specified at the next revision of this TSI);
- 4.2.6.3 Cross winds (To be specified at the next revision of this TSI);
- 4.2.8 Maintenance file.

For these exceptions, national rules apply.

With regards to wagons operating under the agreements specified in 7.5 below, the conditions to be applied when renewing or upgrading these wagons are those mentioned in the relevant agreements, if any. In the absence of such conditions, this TSI is applicable.

7.4.3. ADDITIONAL REQUIREMENTS FOR WAGON MARKING

In addition to the general case above for upgraded or renewed freight wagons, all existing interoperable freight wagons are required to comply with the requirements of this TSI with respect to the design of wagon markings from the date of the next overall repainting of the wagon without the intervention of a notified body. A Member State is permitted to define an earlier date of compliance.

7.5. *WAGONS OPERATING UNDER NATIONAL, BILATERAL, MULTILATERAL OR INTERNATIONAL AGREEMENTS*

7.5.1. EXISTING AGREEMENTS

Member States shall notify the Commission, within 6 months after the entry into force of this TSI, of the following agreements under which freight wagons related to the scope of this TSI (construction, renewal, upgrading, placing in service, operation and management of wagons as defined in chapter 2 of this TSI) are operated:

- National, bilateral or multilateral agreements between Member States and Railway Undertakings or Infrastructure Managers, agreed on either a permanent or temporary basis, and required due to the very specific or local nature of the intended transport service;
- bilateral or multilateral agreements between Railway Undertakings, Infrastructure Managers or between Safety Authorities, which deliver significant levels of local or regional interoperability;
- international agreements between one or more Member States and at least one third country, or between Railway Undertakings or Infrastructure Managers of Member States and at least one Railway Undertaking or Infrastructure Manager of a third country, which deliver significant levels of local or regional interoperability.

**▼B**

Continued operation/maintenance of wagons covered by these agreements shall be permitted as far as they do comply with Community legislation.

The compatibility of these agreements with EU legislation including their non-discriminatory character and, in particular, this TSI, will be assessed and the Commission will take the necessary measures such as, for example, the revision of this TSI to include possible specific cases or transitional measures.

The RIV Agreement and COTIF instruments shall not be notified.

## 7.5.2. FUTURE AGREEMENTS

Any future agreement or modification of existing agreements shall take into account EU legislation and, in particular, this TSI. Member States shall notify the Commission with such agreements/-modifications. The same procedure of § 7.5.1 then applies.

**▼M1**7.6. *AUTHORISATION FOR PLACING IN SERVICE OF TSI CONFORM WAGONS*

7.6.1. In accordance with Article 17(1) of Directive 2008/57/EC, where compliance with the TSIs has been achieved and an EC Declaration of Verification is issued within one Member State for freight wagons, this shall be mutually recognised by all Member States.

7.6.2. When seeking authorisations of placing in service under Article 21 of Directive 2008/57/EC, applicants may seek authorisations for placing in service of grouped wagons. Wagons may be grouped according to series, in which case Article 21(13) of Directive 2008/57/EC applies, or according to type, in which case Article 26 of that Directive applies.

7.6.3. In accordance with Article 21(5) of Directive 2008/57/EC, the authorisation for placing in service granted by one Member State shall be valid in all Member States unless additional authorisations are requested. However Member States may use this possibility only under the conditions specified in Articles 23 and 25 of that Directive. In accordance with Article 23(4) of that Directive, one of the conditions allowing a Member State to request for an 'additional authorisation' procedure is the case of open points related to technical compatibility between infrastructure and vehicles. To this end, Annex JJ sets out the list of open points as requested in Article 5(6) of that Directive and also identifies those open points that may require additional checks with a view to ensuring technical compatibility between infrastructure and vehicles.

7.6.4. An authorisation of placing in service granted by one Member State shall be valid in all other Member States under the following conditions:

- (a) the wagon has been authorised in accordance with Article 22 of Directive 2008/57/EC, on the basis of this TSI, including the verifications related to the open points identified in Annex JJ part 1;
- (b) the wagon is compatible with the 1435 mm track gauge;
- (c) the wagon has a G1 loading gauge, as specified in Annex C3;
- (d) the wagon is equipped with an axle distance that does not exceed 17 500 mm between two adjacent axles;
- (e) the wagon complies with the requirements of Annex JJ part 2.

7.6.5. Even if a wagon has been authorised for placing in service, there is a need to ensure that it is operated on compatible infrastructures; this may be done through the use of Infrastructure and Rolling Stock registers.

**▼B**7.7. *SPECIFIC CASES*

## 7.7.1. INTRODUCTION

The following special provisions are permitted in the specific cases below.

These specific cases belong to two categories: the provisions apply either permanently (case ‘P’), or temporarily (case ‘T’). In temporary cases, it is recommended that the Member States concerned should conform with the relevant subsystem either by 2010 (case ‘T1’), an objective set out in Decision No 1692/96/EC of the European Parliament and of the Council of 23 July 1996 on Community guidelines for the development of the trans-European transport network, or by 2020 (case ‘T2’).

## 7.7.2. LIST OF SPECIFIC CASES

**General specific case on the network of 1 524 mm****Member State: Finland****Case ‘P’:**

In the territory of Finland and at Swedish cross-border station Haparanda (1 524 mm), the bogies, wheelsets and other track gauge interfaces related interoperability constituents or/and subsystems built for track gauge 1 524 mm network are only accepted, if they comply with the following mentioned Finnish specific cases for track gauge interfaces. Without prejudice to the above-mentioned restriction (1 524 mm gauge) all the interoperability constituents and/or subsystems complying with the TSI requirements for 1 435 mm track gauge are accepted at Finnish cross-border station Tornio (1 435 mm) and at train-ferry harbours on the tracks for 1 435 mm.

7.7.2.1. *Structures and mechanical parts:*7.7.2.1.1. **Interface (e. g. Coupling) between vehicles, between set of vehicles and between trains**7.7.2.1.1.1. *Track gauge 1 524 mm***Member State: Finland****Case ‘P’**

For vehicles, which are intended for traffic in Finland, the distance between buffer centrelines is permitted to be 1 830 mm. Alternatively, it is permitted that these wagons be equipped with SA-3 couplers, *or SA-3 compatible couplers*, with or without side buffers.

For vehicles which are intended for traffic in Finland it is required that where the distance between the buffer centrelines is 1 790 mm, the width of the buffer plates shall be increased by 40 mm towards the outside.

7.7.2.1.1.2. *Track gauge 1 520 mm***Member State: Poland, Slovakia, Lithuania, Latvia, Estonia, Hungary****Case ‘P’**

**All wagons intended to operate occasionally on 1 520 mm track gauge in Poland and Slovakia on selected 1 520 mm lines, Lithuania, Latvia and Estonia** shall meet the following requirements:

Each wagon compliant with this TSI for track gauge 1 520 mm and 1 435 mm shall be equipped both with automatic coupler and screw coupling according to one of the following solutions:

- the kind of coupler can be changed at the border between the 1 435 mm and 1 520 mm networks

**▼B**

- or
- the wagon can be equipped with buffers and automatic coupler type SA3 and intermediate coupler
- or
- the wagon can be equipped with hidden buffers and automatic coupler; buffers in advanced position shall allow operating a wagon with screw coupling or intermediate coupler.

*Buffers and couplers — version C*

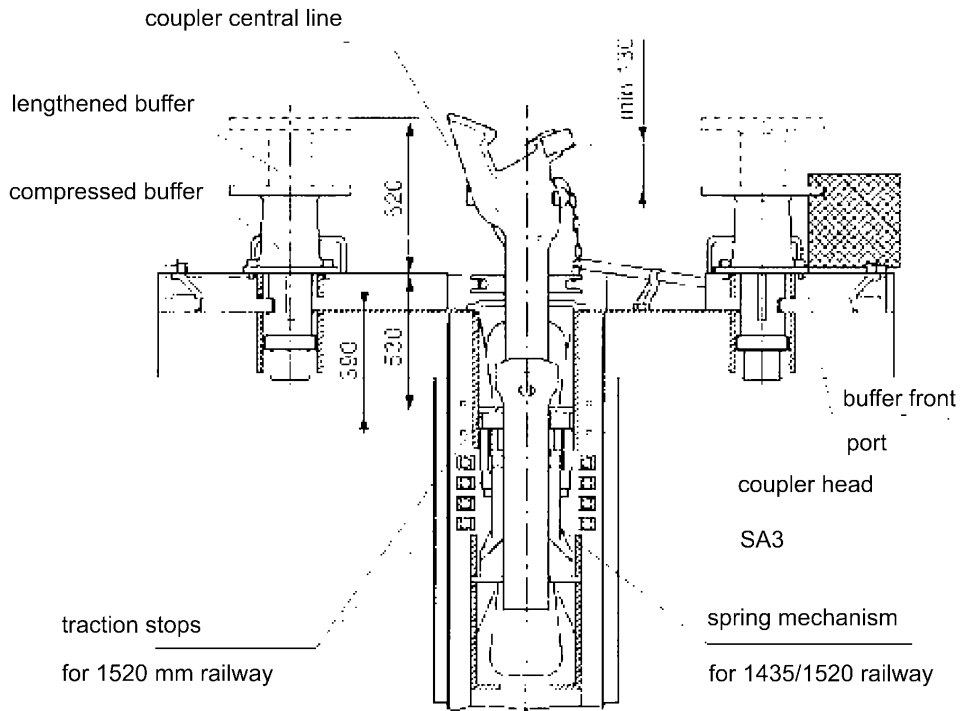

**Coupler Version D**

**Stellung Automatische Kupplung**

**A - A**

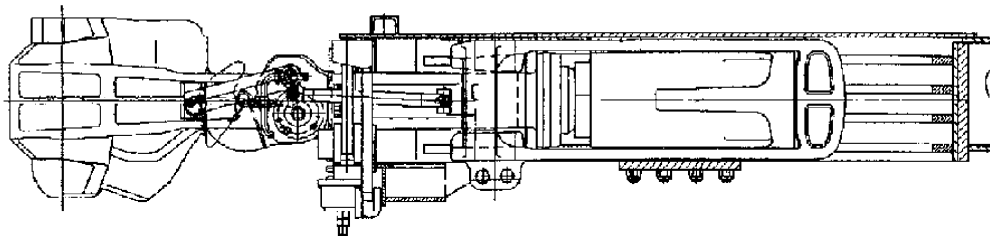



▼B

## Stellung Zughaken (Automatische Kupplung abgeklappt)

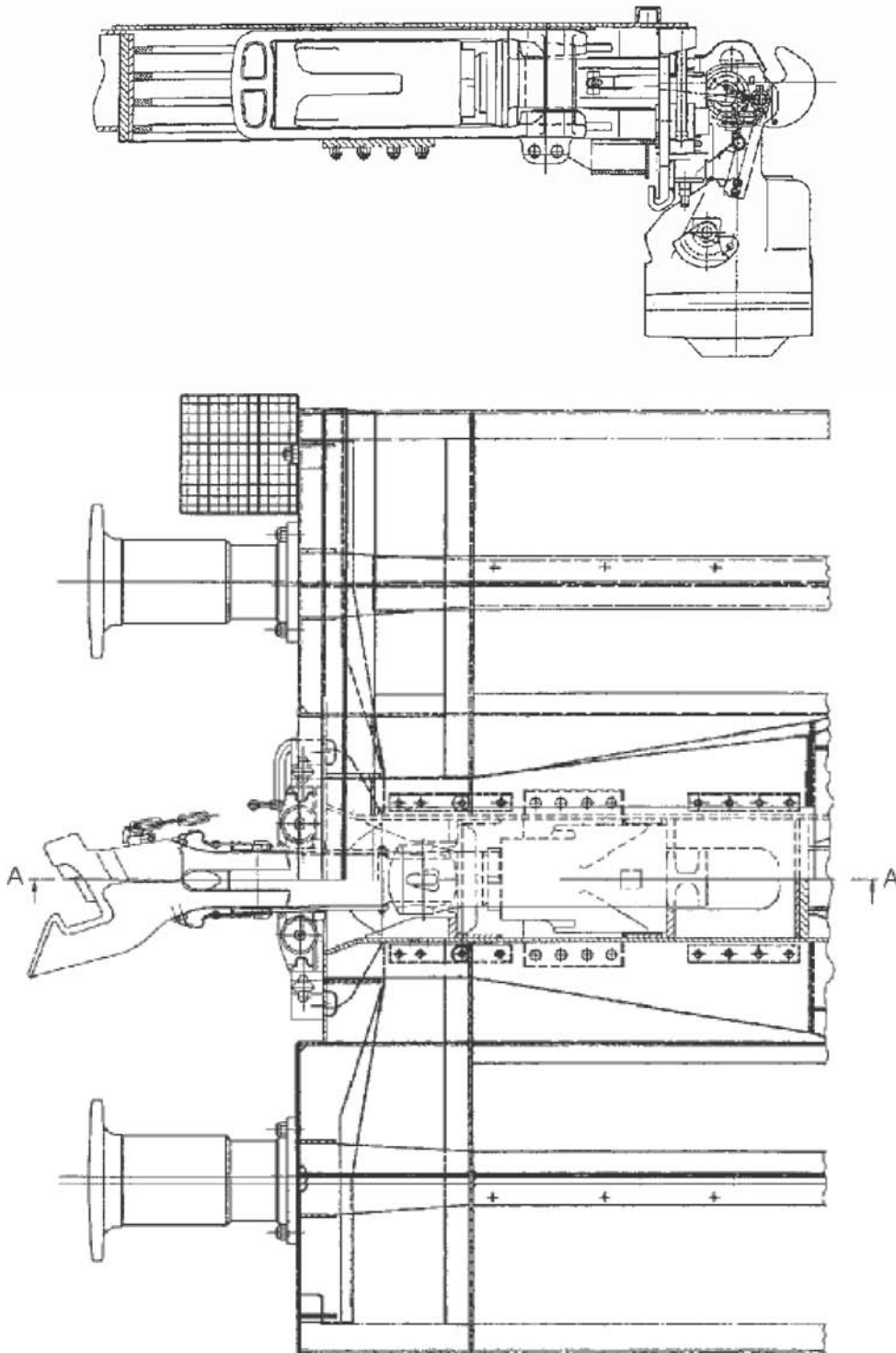
**Buffer and Coupler Version D**

Tank wagons for dangerous goods shall be equipped with couplers shock absorber complying with following parameters:

- dynamic absorption minimum 130 kJ
- terminal force under quasi-static loading minimum 1 000 kN.

**▼B**7.7.2.1.1.3. *Track gauge 1 520 mm / 1 524 mm***Member State: Lithuania, Latvia, Estonia, Finland and Poland****Case ‘P’**

With regards to wagons operating, or intended to operate, in bilateral traffic permanently on 1 520 mm / 1 524 mm lines between Member States and third countries, sections 4 and 5 of this TSI are not applicable.

7.7.2.1.1.4. *Track gauge 1 520 mm***Member State: Lithuania, Latvia, and Estonia****Case ‘T’**

For wagons operating permanently on 1 520 mm lines between Member States, sections 4 and 5 of this TSI are not applicable until the next revision of this TSI. The next revision shall take into consideration the specific cases as identified from the process given in 7.5.1 of this TSI.

7.7.2.1.1.5. *Track gauge 1 668 mm — Distance between buffers centrelines***Member State: Spain and Portugal****Case ‘P’**

For vehicles, which are intended for traffic to Spain or Portugal, it is permissible for the distance between buffer centrelines to be 1 850 mm ( $\pm$  10 mm). In this case the compatibility with buffers in a standard arrangement shall be demonstrated.

Buffer plates dimensions for two-axle wagons and bogie wagons:

Unified width of buffer plates for wagons which are intended for traffic to Spain or Portugal (distance between centrelines 1 850 mm) shall be 550 mm or 650 mm depending of characteristics of wagons included in applicable national regulations.

7.7.2.1.1.6. *Interface between vehicles***Member State: Republic of Ireland and Northern Ireland****Case ‘P’**

For Ireland, the buffer centres are 1 905 mm apart, and the buffer and draw gear centre heights above the rail must be between 1 067 mm min. and 1 092 mm max with no load on the wagon. To facilitate coupling and uncoupling during shunting, ‘instantor’ link couplings may be permitted on freight wagons (see Annex HH).

7.7.2.1.1.7. *General specific case on the network of 1 000 mm or less***Member state: Greece****Case ‘T1’:**

For the existing isolated 1 000 mm gauge, which is not in the scope of this TSI, national rules shall apply.

7.7.2.1.2. **Safe access and egress for rolling stock**7.7.2.1.2.1. *Safe access and egress for rolling stock Republic of Ireland and Northern Ireland***Member State: Republic of Ireland and Northern Ireland****Case ‘P’**

For Ireland, the requirement will be that ‘steps and handrails where provided will be for access and egress only, and not to permit the shunter to ride on the outside of the vehicle.’

**▼B**

*Annex EE is not applicable in the Republic of Ireland and Northern Ireland.*

7.7.2.1.3. **Strength of main vehicle structure and securing of freight**

7.7.2.1.3.1. *1 520 mm gauge lines*

**Member State: Poland, Slovakia, Lithuania, Latvia, Estonia, Hungary**

**Case 'P'**

All wagons intended to operate permanently or occasionally on 1 520 mm track gauge shall meet the following requirements:

**Design loads**

Longitudinal design loads

Category	Minimal values [kN]
Compressive force at automatic coupler level	3 000
Tractive force at automatic coupler level	2 500
Compressive force at axis at each buffer	1 000
Compressive force applied eccentric (50 mm) from axis at each buffer	750
Compressive force applied diagonally via side buffers (if fitted)	400

Vehicles meeting these requirements can be shunted without restriction.

— **Maximum Vertical Load**

Load of a wagon in boundary design condition at 150 % of maximum load shall not cause plastic strain.

Deflection of a wagon frame related to standstill shall be not more than 3 ‰ of king-pin base.

— **Load combinations**

The structure shall conform to load combinations from the most inconvenient case of vertical load combined with compressive force 3 000 kN at automatic coupler and forces applied to axis at each buffer.

Vertical, dynamical surplus resulting from reaction inertial force of load on body of a wagon and its horizontal components reacting transversely to track shall be considered by calculation.

For tank wagons internal pressure, partial vacuum and pressure from hydraulic shock shall be considered in addition.

— **Load during lifting**

Wagon shall be resistant to forces during lifting without plastic strain. Additional points of support under norms to 1 520 mm vehicles should be regarded.

**Requirements for dynamic forces applied at automatic coupler**

— **General**

A loaded and unloaded freight wagon shall be resistant to the impact of a ram wagon. This shall be demonstrated by a test on a straight track. The weight of the ram wagon shall be equal to at least the weight of the tested wagon. For tests of two-axle wagons a ram wagon of  $100 \pm 3$  t is recommended.

**▼B**

A ram wagon shall be equipped with automatic coupler type SA3 and a coupler shock absorber. The difference between the axes of automatic couplers shall not exceed 50 mm.

The test shall apply with the following specifications:

- single test wagon not braked;
- contra-ram formed by 3 or 4 wagons formed as a group at least 300 t mass.

The applied force in loaded state shall be 3 000 kN  $\pm$  10 %.

The contra ram group of wagons shall be protected against rolling by hand-brake or braking skids.

— **Impact in unloaded state**

The speed of the ram wagon shall be 12 km/h. The tested wagon shall be unbraked.

Loads shall not cause any plastic deflection. Tensions in selected critical points such as connection bogie/frame, frame/wagon body and superstructure shall be recorded.

— **Impact in loaded state**

The tested wagon shall be loaded with the maximum load.

The maximum speed of the ram wagon shall be 12 km/h. Impact tests shall start gradually from 2 to 3 km/h.

The test shall be performed for the following ranges:

- up to 5 km/h,
- 5 to 10 km/h,
- above 10 km/h.

At least 5 impacts shall be carried out for each speed range. Additionally, 3 impact tests shall be carried out with the impact of a compressive force equals 3 000 kN. This impact force shall be supported by calculation.

During the tests the permissible impact compressive force shall not exceed the limit of more than 10 %. If a boundary value of 3 000 kN  $\pm$  10 % is reached just below 12 km/h the speed shall not be increased.

Additionally in order to simulate long-term sustainability 40 impact test shall be carried out either at 12 km/h or with an impact compressive force of 3 000 kN.

Loads shall not cause any plastic deflection.

— **Dynamic strength condition during operation of wagons**

Wagons shall be resistant to longitudinal compressive and tractive forces of 1 000 kN at 120 km/h.

7.7.2.1.3.2. *1 668 mm gauge lines — Lifting and jacking*

**Member State: Spain and Portugal**

**Case ‘P’**

*For two-axle wagons:*

- Provision shall be made to limit the drop of the spring when the wagon is lifted.

An example of solution is shown in Annex X Plate 3.

- For lifting by jacks (limited to the ‘connections’ at the maximum), each wagon shall be fitted with four base plates, two under each underframe sole-bar, placed symmetrically in relation to the transverse axis of the wagon.

This arrangement may also be appropriate for new axle changeover pit facility (including for multiple or articulated wagons with no limitation on number of units).

**▼B**

Base plates shall have the following dimensions:

- In the longitudinal direction of the wagon: 150 mm at the maximum.
- In the transverse direction of the wagon: 100 mm.
- Thickness: 15 mm.

They shall be cross-grooved, with the slots parallel and perpendicular to the longitudinal axis of the wagons:

- Groove depth: 5 to 7 mm approximately.
- Groove width: 4 to 6 mm approximately.

The wagon infrastructure shall provide for clearance of the wheelsets when the base plates, when in the raised position (with normal lifting jack movement of 800 mm), reach a maximum height of 1 550 mm in relation to rail level.

Annex X Plate 6 shows the clearances to be provided on wagons for engaging the lifting-jack heads.

*For bogie wagons:*

- Bogies with interchangeable axles shall be fitted with a device to limit the descent of the springs on lifting the wagons with their bogies.

It is recommended that the device shown in Annex X Plate 10 be adopted.

- The maximum wagon length over buffers may not exceed 24,486 m. The underframe structure shall be capable of bearing the weight of the bogie frames during of lifting in the conditions defined in the next paragraph.
- The positioning of lifting jacks on work sites shall comply with the diagram shown in Annex X Plate 13.

The arrangements adopted are appropriate for handling all wagons with an overall length not exceeding 24,480 m.

The wagon lifting operations shall be effected by simultaneous raising of the underframe and bogie frames. The wagons shall be provided with cables to secure the bogie frames to the body during these operations. Annex X Plate 14 shows the devices fitted to the bogies at 4 points and to the wagon underframe at 8 points, to enable such securing to be carried out at the time of lifting and the cables to be placed in the idle position when not in use.

Wagon underframes shall be fitted with base plates to the following dimensions:

- Length in longitudinal direction of wagon: 250 mm minimum.
- Width in transverse direction of wagon: 100 mm.
- Thickness: 15 mm.

The contact surface of base plates shall be grooved in accordance with indications given in paragraph relating to 2-axle wagons.

The position of the base-plates on the wagon underframes and the clearances to be provided for engaging the lifting jacks noses are represented in Annex X Plate 15. This position is appropriate for new axle-changeover pit installing (also for multiple or articulated wagons with no limitation on the number of units).

The wagon infrastructure shall provide for clearance of the wheelsets when the base-plates, in the raised position (with normal lifting jack movement of 900 mm), reach a maximum height of 1 650 m in relation to rail level.

**▼B**

- 7.7.2.2. **Vehicle track interaction and gauging**
- 7.7.2.2.1. **Kinematic gauge**
- 7.7.2.2.1.1. *Kinematic gauge Great Britain*
- Member State: Great Britain**
- Case ‘P’**
- For wagons intended to run on the British network, see Annex T.
- 7.7.2.2.1.2. *1 520 mm and 1 435 mm track gauge wagons*
- Member State: Poland, Slovakia, Lithuania, Latvia and Estonia**
- Case ‘P’**
- For wagons intended to run on 1 520 mm and 1 435 mm track gauge, see Annex U.
- 7.7.2.2.1.3. *Kinematic gauge Finland*
- Member State: Finland**
- Case ‘P’**
- For wagons which are intended only for traffic in Finland and at the Swedish cross-border station Haparanda (1 524 mm), the vehicle gauge shall not exceed the gauge FIN 1 as defined in Annex W.
- 7.7.2.2.1.4. *Kinematic gauge Spain and Portugal*
- Member State: Spain and Portugal**
- Case ‘P’**
- Passing over vertical transition curves (including marshalling yard humps) and over braking, shunting or stopping devices.
- It shall be possible for bogies to negotiate an angle of elevation for access to ferry-boats, whose maximum link-span angle with the horizontal is 2° 30' on 120 m curves.
- Passing over curves.
- It shall be possible for the wagons to run through curve of 60 m radius for flat wagons and 75 m for other types on standard-gauge track and through curves of 120 m on broad-gauge track.
- 7.7.2.2.1.5. *Kinematic gauge Ireland*
- Member State: Republic of Ireland and Northern Ireland**
- Case ‘P’**
- Dynamic wagon loading gauge:*
- Freight wagons operating between Ireland and Northern Ireland shall conform to the Iarnród Éireann wagons dynamic loading gauge and the Northern Ireland (GNR) wagons dynamic loading gauge shown on the composite gauge drawing no. 07000/121 Annex HH. Static wagon gauge dimensions indicated on this drawing must also be respected.
- Wagon construction:*
- The maximum construction gauge of the wagons shall be determined in accordance with the national rules.
- 7.7.2.2.2. **Static axle load, dynamic wheel load and linear load**
- 7.7.2.2.2.1. *Static axle load, dynamic wheel load and linear load Finland*
- Member State: Finland**
- Case ‘P’**
- For vehicles intended for traffic in Finland, the admissible axle load shall be 22,5 tonnes at the maximum speed of 120 km/h and 25 tonnes at the maximum speed of 100 km/h, when the wheel diameter is between 920 to 840 mm.

**▼B**7.7.2.2.2. *Static axle load, dynamic wheel load and linear load Great Britain***Member State: Great Britain****Case ‘P’**

The classification of lines and line sections in Great Britain is carried out according to the Notified National Standard (Railway Group Standard GE/RT8006 ‘Interface between Rail Vehicle Weights and Underline Bridges’). Vehicles intended to operate in Great Britain shall obtain classification according to this standard.

The classification for the wagon is determined according to the geometrical position and the loads on each axle.

7.7.2.2.3. *Static axle load, dynamic wheel load and linear load Lithuania, Latvia, Estonia***Member State: Lithuania, Latvia, Estonia****Case ‘P’**

For the vehicle gauge national rules shall be applied.

7.7.2.2.4. *Static axle load, dynamic wheel load and linear load Republic of Ireland and Northern Ireland***Member State: Republic of Ireland and Northern Ireland****Case ‘P’**

The static axle load limit for wagons is 15,75 tonnes for the Irish network, but the operation of bogie wagons with 18,8 tonne axle loading is permitted on certain routes.

7.7.2.3. **Rolling stock parameters which influence ground based train monitoring systems**7.7.2.4. **Vehicle dynamic behaviour**

Category ‘P’ — permanent

7.7.2.4.1. *List of specific cases of wheel diameter related to various track gauges.*

Designation	Wheel diameter (mm)	Gauge (mm)	Minimum value (mm)	Maximum value (mm)
Distance between outside surfaces of the flange ( $S_R$ )	$\geq 840$	1 520	1 487	1 509
		1 524	1 487	1 514
		1 602		
		1 668	1 643	1 659
Distance between inner faces of the flange ( $A_R$ )	$\geq 840$	1 520	1 437	1 443
		1 524	1 442	1 448
		1 602		
		1 668	1 590	1 596
Width of the rim ( $B_R$ )	$\geq 330$	1 520	133	140 (1)
Thickness of the flange ( $S_d$ )	$\geq 840$	1 520	24	33
	$< 840$ and $\geq 330$	others	27,5	33

**▼ B**

Designation	Wheel diameter (mm)	Gauge (mm)	Minimum value (mm)	Maximum value (mm)
Height of the flange ( $S_h$ )	$\geq 760$		28	36
	$< 760$ and $\geq 630$		30	36
	$< 630$ and $\geq 330$		32	36
Face of flange ( $Q_R$ )	$\geq 330$		6.5	

Sizes above are indicated as a function of the height of the upper rail level and shall be met by empty or full wagons.

(<sup>1</sup>) Burr value included

The wheel sets of freight wagons running permanently on 1 520 mm gauge shall be measured in accordance with the wheel set measurement procedure specified for 1 520 mm freight wagons.

7.7.2.2.4.2. *Material for wheels:*

According to the Nordic climatic conditions, a specific wheel material is generally used in Finland and in Norway. It is similar to ER8 but with a level of manganese and silicon increased to improved properties against shelling. For domestic traffic this material may be used if agreed between the parties.

7.7.2.2.4.3. *Specific loads cases:*

Additional forces shall be used if the parameters of the line generate higher forces.

(e.g.: small curves ...)

7.7.2.2.4.4. *Vehicle dynamic behaviour Spain and Portugal*

**Member State: Spain and Portugal**

**Case 'P'**

Width of the rim.

In the case of axle designed for 22,5 t loads, use may be made of those whose drawings are given in Annex X Plate 1 and which are derived for the ERRI standard axle design. Additional arrangements shall be made in some cases so as to comply with the gauge of the active surfaces of the wheel flanges of the axle included in the present TSI.

7.7.2.2.4.5. *Vehicle dynamic behaviour Republic of Ireland and Northern Ireland*

**Member State: Republic of Ireland and Northern Ireland**

**Case 'P'**

Rolling stock should be designed to operate safely over a track twist of up to 17<sup>o</sup>/<sub>oo</sub> over a 2,7 m base, and up to 4<sup>o</sup>/<sub>oo</sub> over a 11,2 m base.

The maximum and minimum values for  $S_R$  and  $A_R$  are as follows:

$S_R$	All wheel diameters	1 571 mm min.	1 588 mm max.
$A_R$	All wheel diameters	1 523 mm min	1 524 mm max.
$B_R$	All wheel diameters	127 mm min.	135 mm max.
$S_d$	All wheel diameters	24 mm min	32 mm max.
$S_h$	All wheel diameters	30,5 mm min.	38 mm max.
$Q_R$	All wheel diameters	6,5	



**▼B****7.7.2.2.5. Longitudinal compressive forces**

7.7.2.2.5.1. *Longitudinal compressive forces Poland and Slovakia in selected 1 520 mm lines, Lithuania, Latvia and Estonia*

**Member State: Poland and Slovakia in selected 1 520 mm lines, Lithuania, Latvia and Estonia**

**Case ‘P’**

Requirements for 1 520 mm gauge wagons for wagons of gauge 1 435 mm to operate on 1 520 mm network.

Countries: Poland and Slovakia in selected 1 520 mm lines, Lithuania, Latvia, Estonia

Wagons equipped with automatic couplers shall be resistant to longitudinal compressive and tractive forces of 1 000 kN at 120 km/h.

**7.7.2.2.6. Bogie and Running Gear**

7.7.2.2.6.1. *Bogie and Running Gear Poland and Slovakia in selected 1 520 mm lines, Lithuania, Latvia, Estonia*

**Member State: Poland and Slovakia in selected 1 520 mm lines, Lithuania, Latvia, Estonia**

**Case ‘P’**

In Poland and Slovakia in selected 1 520 mm lines, Lithuania, Latvia, Estonia, the requirements for wagons with variable-gauge running gear of 1 435 mm/1 520 mm gauge required to operate on 1 520 mm network are the following.

## a) General

For two-axle bogies permissible wheelset spacing shall be between 1 800 mm and 2 400 mm.

Running gear intended for use on European rail networks of 1 520 mm gauge shall be able to withstand an operating temperature range of - 40 °C to + 40 °C. For Asian 1 520 mm gauge networks, running gear shall be suitable for a temperature range of - 60 °C to + 45 °C and a relative humidity of 0-100 %.

## b) Running gear frames

The running gear frame may be welded or cast. The steel used shall be weldable without pre-heating and shall have a minimum tensile strength of 370 N/mm<sup>2</sup>. The minimum values to be obtained for notched bar impact strength (V notch as specified for ISO test) are summarised in the following table:

Notched bar impact strength [J]		
-20 °C	-40 °C	-60 °C
27	27	21

Proof required for running on 1 520 mm gauge system only.

7.7.2.2.6.2. *Bogie and Running Gear Spain and Portugal*

**Member State: Spain and Portugal**

**Case ‘P’****Overall dimensions of bogie.**

Bogies with interchangeable axles shall have a minimum wheelbase of 1,80 m and a distance between suspension planes of 2,170 m. The overall dimensions of the bogie are given in Annex X Plate 7. The overall dimensions thus defined apply to a bogie suitable for S braking conditions. The French and Spanish National Authorities shall be consulted over application of the SS braking conditions.

**▼B**

The height of the pivoting centre shall be 925 mm above rail level and the radius of the pivoting bearing shall be 190 mm as for the standard-gauge bogie. The pivot shall comply with the drawing in Annex X Plate 8.

**Axle box for wagon bogies.**

Axle boxes shall comply with the drawing shown in Annex X Plate 9.

**Retractable safety device linking axle to bogie frame.**

Axle boxes shall comprise a safety system enabling the axles to be secured to the bogie frame. Such a device, shown in Annex X Plate 11, shall be retractable during axle changeover operations.

**Wheels.**

For two-axle wagons:

The diameter of the running tread of new wheels shall be 1 000 mm maximum.

For bogie wagons:

The diameter of the running tread of new wheels shall be 920 mm.

**Wheelsets.**

The wheelsets shall bear a serial number, a type number and the owner's mark.

These indications, together with the date (month and year) of the last overhaul of the wheelsets, the code index of the owning or registering railway, and the index of the location which has carried out the overhaul, shall be shown on a floating collar on the axle shaft.

The code number of the owning or registering railway and the date (month and year) of the last overhaul shall be reproduced in white paint on the front of each axle box.

**Axle box and guard plates.**

The axle boxes, axle guards and spring buckles shall be designed to enable the indications shown in Plate 2 to be respected (the diameter of the hole in the upper side of the axle box shall allow for the use of a ring or stop for adjustment of the suspension, as shown in Annex X).

As the wheel of the broad-gauge axle are quite close to the wagon underframe, a stirrup with 14 or 10 mm axle-guard shall be used: see Plate 18.

It is recommended that use should be made of axle-guard stays that can be removed and assembled quickly. They shall be fixed by means of 2 M-20 × 55 bolts fitted with growed washers. On construction, the distance between hole centres shall be 483 +1/0 mm.

**Overall surface area of wheelsets.**

The underframes of vehicles shall have a completely unobstructed space, level with each wheel, as shown in Plate 4.

**Axle design**

The axles shall be capable of supporting the maximum load laid down for lines suitable for 20t axle-loads (lines in category C) or for 22,5t axle-loads (lines in category D). They shall be fitted with roller bearing axle boxes and be interchangeable with existing axles. The new axles shall be designed in accordance with the provisions laid down in the present TSI. The use of automatic variable-gauge wheelsets, which are able to run on both 1 435 mm and 1 668 mm lines, are allowed only with the agreement of Spanish and French competent Authorities for international transport through this latter Member State.

**▼B**7.7.2.3. **Braking**7.7.2.3.1. **Braking performance**7.7.2.3.1.1. *Braking performance Great Britain***Member State: Great Britain****Case 'P'**

Freight wagons intended for use on the British network see Annex V section V2

7.7.2.3.1.2. *Braking performance Poland and Slovakia in selected 1 520 mm lines, Lithuania, Latvia, Estonia***Member State: Poland and Slovakia in selected 1 520 mm lines, Lithuania, Latvia, Estonia****Case 'P'****— Distributors**

Interoperability wagons for 1 435 mm to operate on 1 520 mm network shall be equipped with additional braking systems in accordance with the following:

Option 1: fit two distributors with a changeover device

— for the 1 435 mm gauge: distributor according to Annex I

— for the 1 520 mm gauge: type 483 distributor

Option 2: fit a standard distributor or an approved KE/483 distributor combination on the wagon that meets the technical braking requirements of both 1 435 mm and 1 520 mm gauge railways, with a changeover device allowing the system to switch to the respective operating regime.

Under option 1, the wagon's brake equipment must include 'brake on/off' and 'freight/passenger' changeover devices as well as an 'empty/loaded' device if there is no automatic load-proportional braking facility. According to Annex I and a 'brake on/off' and 'empty — partly loaded — loaded' device as per the standards for the 1 520 mm gauge and the 'Technical Requirements for the Brake Equipment of Wagons built in RF Workshops'.

Each distributor must have its own release valve with a pull chord with handles on both sides of the wagon.

For braking option 2, a distributor should preferably be used in combination with an automatic load-proportional braking system. When the braking position is switched over manually in accordance with the load, there must be at least two graduated positions for the braking force.

**— Load-proportional braking, brake power and brake performance**

The wagon's brakes must ensure that the prescribed values for the braked weight and the theoretical brake force coefficients are guaranteed for operation on both 1 435 mm and 1 520 mm gauges at the respective maximum speeds.

For operation on the 1 435 mm gauge, wagons shall be fitted with either a hand-operated load-changeover device or an automatic load-proportional braking system meeting the requirements according to Annex I.

For operation on the 1 520 mm gauge, wagons shall be fitted with either an automatic load-proportional braking system or a hand-operated load-changeover device with at least two positions. Use of the automatic system and its configuration for the 1 520 mm track gauge shall give due consideration to the bogie design used and the type of transition from one gauge to the other.

**▼B**

Brake performance shall be calculated on the basis of the 'Standard Braking Calculation for Freight and Refrigerator Wagons'. Here, the theoretical coefficient calculated for the wagon brake block force when the brake system is switched on to the 1 520 mm gauge shall satisfy the following values:

- for K (composite) brake blocks: at least 0,14 up to a maximum of 0,31 for a fully-laden wagon and at least 0,22 up to a maximum of 0,37 for an empty wagon;
- for GG (cast-iron) brake blocks: at least 0,36 up to a maximum of 0,70 for a fully-laden wagon and at least 0,62 up to a maximum of 0,81 for an empty wagon.

The different wagon braking forces specified in the standards for operation on 1 435 mm and 1 520 mm track gauges can be accommodated by an appropriate adjustment to the brake rigging or the brake cylinder.

— **Changeover device for switching from 1 435 to 1 520 mm track gauges**

The changeover from one distributor system to another shall take place during the gauge changeover operation using the 1 435 mm/1 520 mm changeover device. Actuation of this device must require minimum effort and must jack reliably into its final position. The final position selected must correspond to one braking system only and must render the second braking system non-operational. When one braking system fails, the other must remain operational, assuming the wagon has two separate distributors.

The switch from one braking system to another may only be effected in the gauge changeover station either manually (by means of a special device) or automatically.

The braking system selected must be clearly indicated, even when the changeover takes place automatically.

Where the changeover takes place automatically, an automatic load-proportional braking system should preferably be used.

7.7.2.3.1.3. *Braking performance Finland*

**Member State: Finland**

**Case 'P'**

For vehicles for 1 524 mm gauge only, braking power shall be determined based on the minimum distance of 1 200 m between signals on the Finnish network. Minimum braked weight percentage is 55 % for 100 km/h and 85 % for 120 km/h.

The requirements for energy limits related to the slope with a mean declivity of 21 ‰ and a length of 46 km (slope of St Gothard's line) are not valid for vehicles for 1 524 mm gauge only.

In vehicles for 1 524 mm gauge only, the parking brake shall be designed such that fully loaded wagons shall be held on a gradient of 2,5 ‰ with maximum adhesion of 0,15 with no wind. In wagons built for the transport of road vehicles the parking brake is operated from the ground.

7.7.2.3.1.4. *Braking performance Spain and Portugal*

**Member State: Spain and Portugal**

**Case 'P'**

Brake-shoe arrangement.

For two-axle wagons:

Brake shoes shall be assembled in accordance with the requirements indicated in Plate 5. The assembly in Plate 12 for bogie wagons may also be used.

For bogie wagons:

Brake shoes shall be assembled in accordance with the provisions in Plate 12.

**▼B**7.7.2.3.1.5. *Braking performance Finland, Sweden, Norway, Estonia, Latvia and Lithuania***Member State: Finland, Sweden, Norway, Estonia, Latvia and Lithuania****Case ‘T1’**

Requirements of this TSI concerning the use of composite blocks approved based on the existing UIC specifications and test methods are not in general valid for Finland, Norway, Sweden, Estonia and Lithuania.

Composite brake blocks shall be assessed on a national basis and shall take into consideration environmental winter conditions.

This specific case is valid until the specifications and assessment methods have been further developed and proven to be sufficient for Nordic Winter Conditions.

That does not preclude freight wagons from other member states from operating in Nordic and Baltic states.

7.7.2.3.1.6. *Braking performance Republic of Ireland and Northern Ireland***Member State: Republic of Ireland and Northern Ireland****Case ‘P’**

*Service Brake:* The stopping distance of a new wagon operating on straight and level track on the railway network in Ireland must not exceed:

$$\text{Stopping distance} = (v^2 / (2 * 0,55)) \text{ m}$$

(where v = max operating speed of wagon on IR network in m/s)

The maximum operating speed must be less than or equal to 120 km/h. These conditions must be met for all conditions of loading.

7.7.2.3.2. **Parking brake**7.7.2.3.2.1. *Parking brake Great Britain***Member State: UK****Case ‘P’**

Freight wagons intended for use on the British network see Annex V section V1

7.7.2.3.2.2. *Parking brake Republic of Ireland and Northern Ireland***Member State: Republic of Ireland and Northern Ireland****Case ‘P’**

For new wagons used solely on the railway network in Ireland every wagon has to be equipped with a parking brake that must hold a fully loaded wagon on a gradient of 2,5 % with a maximum of 10 % adhesion with no wind.

Ireland requests exception from requirements where the parking brake is to be operated ‘from the vehicle’, in favour of a requirement that ‘the parking brake is to be operated from the vehicle or from the ground’.

7.7.2.4. **Environmental conditions**7.7.2.4.1. **Environmental conditions**7.7.2.4.1.1. *Environmental conditions Spain and Portugal***Member State: Spain and Portugal****Case ‘P’**

In Spain and Portugal the upper external temperature limit is + 50 instead of + 45 given by temperature class Ts in section 4.2.6.1.2.2.

**▼B**7.7.2.4.2. **Fire safety**7.7.2.4.2.1. *Fire safety Spain and Portugal***Member State: Spain and Portugal****Case 'P'**

Spark arrester.

Category 'P'- permanent

For two-axle wagons:

Spark arrester shields shall be constructed and arranged in accordance with Plate 16.

The external part of these shields shall be directed downwards, and their upper part shall be curved.

The width of their upper part shall be 415 +5/0 mm; the distance between inside edges shall be 1 120 mm.

The vertical part of these shields shall be 115 mm in height, and the part pointing downwards 32 mm at 30°. The distance of these shields in relation to the floor shall be 20 mm, and the radius of the curved part 1 800 mm. Axle wagons accepted for transit between France and Spain, with dangerous goods in RID classes 1a and 1b shall have their brake isolated while running.

*For bogie wagons:*

— The spark arrester shields shall be constructed and arranged in accordance with Plate 17.

— They shall be smooth and 500 mm wide.

— The distance between their inside edges shall be 1 100 mm ± 10.

— In relation to the floor, the minimum distance of these shields shall be 80 mm.

7.7.2.4.3. **Electrical protection**7.7.2.4.3.1. *Electrical protection Poland and Slovakia in selected 1 520 mm lines, Lithuania, Latvia, Estonia***Member State: Poland and Slovakia in selected 1 520 mm lines, Lithuania, Latvia, Estonia****Case 'P'**

Additional requirements for 1 520 mm wagons and 1 435 mm wagons to operate on 1 520 mm network.

## 7.7.3. TABLE OF SPECIFIC CASES ARRANGED BY MEMBER STATE

Country	Section	Parameter	Specific case	Category
All countries	4.2.3.4	Vehicle dynamic behaviour	7.7.2.2.4.1.	P
Finland	4.2.2.1	Interface (e.g. coupling) between vehicles	7.7.2.1.1.1	P
Finland	4.2.3.1	Kinematic gauge	7.7.2.2.1.3	P
Finland	4.2.3.2	Static axle load, dynamic wheel load and linear load	7.7.2.2.2.1	P
Finland	4.2.4.1	Braking performance	7.7.2.3.1.3	P



Country	Section	Parameter	Specific case	Category
Finland, Sweden, Norway, Estonia, Latvia and Lithuania	6.2.3.3 (Annex P)	Braking performance	7.7.2.3.1.5	T1
Finland, Estonia, Latvia, Lithuania, Poland	Sections 4 and 5	Subsystem characterisation and interoperability constituents	7.7.2.1.1.3	P
Finland and Norway	5.3.2.3	Wheels	7.7.2.2.4.2	P
Great Britain	4.2.3.1	Kinematic gauge	7.7.2.2.1.1	P
Great Britain	4.2.3.2	Static axle load, dynamic wheel load and linear load	7.7.2.2.2.2	P
Great Britain	4.2.4.1.2.2	Braking performance	7.7.2.3.1.1	P
Great Britain	4.2.4.1.2.8	Parking brake	7.7.2.3.2	P
Greece	4.2.3.4	Vehicle dynamic behaviour	7.7.2.1.1.6	T1
Poland, Slovakia, Lithuania, Latvia and Estonia	4.2.2.1	Interface (e.g. coupling) between vehicles	7.7.2.1.1.2	P
Poland, Slovakia, Lithuania, Latvia and Estonia	4.2.2.3	Strength of main vehicle structure	7.7.2.1.3.1	P
Poland, Slovakia, Lithuania, Latvia and Estonia	4.2.3.1	Kinematic gauge	7.7.2.2.1.2	P
Lithuania, Latvia and Estonia	4.2.3	Static axle load, dynamic wheel load and linear load	7.7.2.2.2.3	P
Lithuania, Latvia and Estonia	Sections 4 and 5	Subsystem characterisation and interoperability constituents	7.7.2.1.1.4	T
Poland, Slovakia, Lithuania, Latvia and Estonia	4.2.3.4	Vehicle dynamic behaviour	7.7.2.2.4	P
Poland, Slovakia, Lithuania, Latvia and Estonia	4.2.3.5	Longitudinal compressive forces	7.7.2.2.5.1	P
Poland, Slovakia, Lithuania, Latvia and Estonia	5.3.2.1	Bogies and running gear	7.7.2.2.6.1	P
Poland, Slovakia, Lithuania, Latvia and Estonia	4.2.4.1	Braking performance	7.7.2.3.1.2	P
Poland, Slovakia, Lithuania, Latvia and Estonia	4.2.7.3	Electrical protection	7.7.2.4.3.1	P
Republic of Ireland and Northern Ireland	4.2.1	Interface (e.g. coupling) between vehicles	7.7.2.1.1.5	P
Republic of Ireland and Northern Ireland	4.2.2.2	Safe access and egress	7.7.2.1.2.1	P
Republic of Ireland and Northern Ireland	4.2.3	Static axle load, dynamic wheel load and linear load	7.7.2.2.2.4	P
Republic of Ireland and Northern Ireland	4.2.3.4	Vehicle dynamic behaviour	7.7.2.2.4.5	P
Republic of Ireland and Northern Ireland	4.2.4.1	Braking performance	7.7.2.3.1.5	P

**▼B**

Country	Section	Parameter	Specific case	Category
Republic of Ireland and Northern Ireland	4.2.4.1.2.8	Parking brake	7.7.2.3.2.2	P
Spain and Portugal	4.2.2.1	Interface (e.g. coupling) between vehicles	7.2.1.1.4	P
Spain and Portugal	4.2.2.3	Strength of main vehicle structure	7.7.2.1.3.2	P
Spain and Portugal	4.2.3.1	Kinematic gauge	7.7.2.2.1.4	P
Spain and Portugal	4.2.3.4	Vehicle dynamic behaviour	7.7.2.2.4.4	P
Spain and Portugal	5.3.2.1	Bogies and Running Gear	7.7.2.2.6.2	P
Spain and Portugal	4.2.4.1	Braking performance	7.7.2.3.1.4	P
Spain and Portugal	4.2.6.1.2.2	Environmental conditions	7.7.2.4.1.1	P
Spain and Portugal	4.2.7.2	Fire Safety	7.7.2.4.2.1	P



▼ B

ANNEX A

STRUCTURES AND MECHANICAL PARTS

A.1. Buffers

Fig. A1

Buffer supporting plate

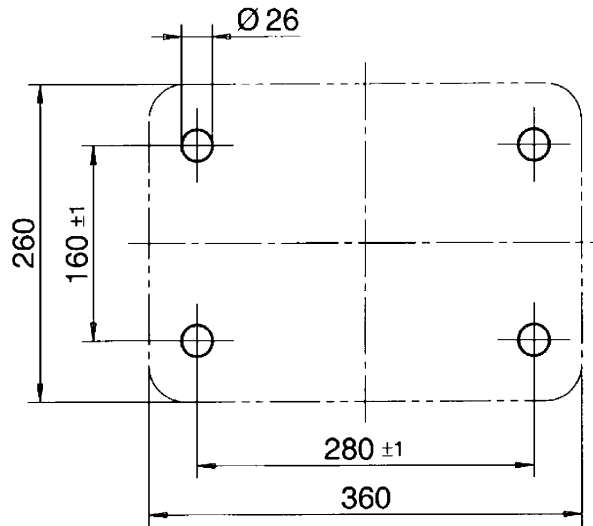

A.2. Draw Gear

Fig. A2

Draw hook — dimensions

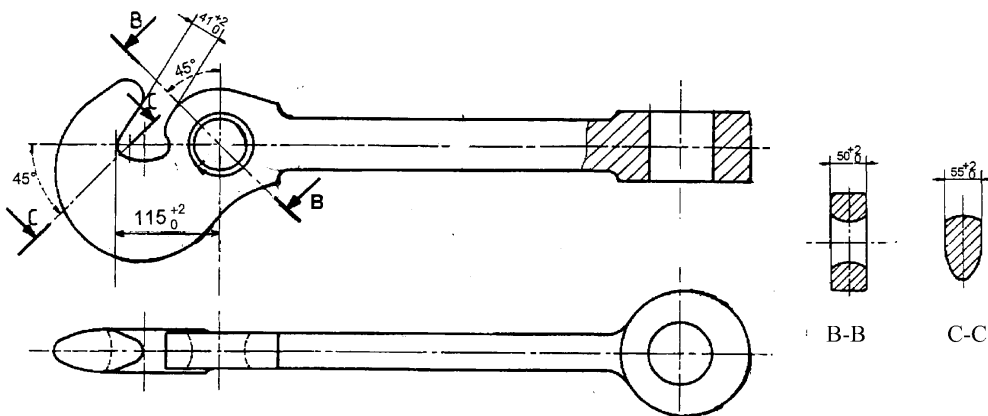

▼B

Fig. A3

D-shackle for screw coupler

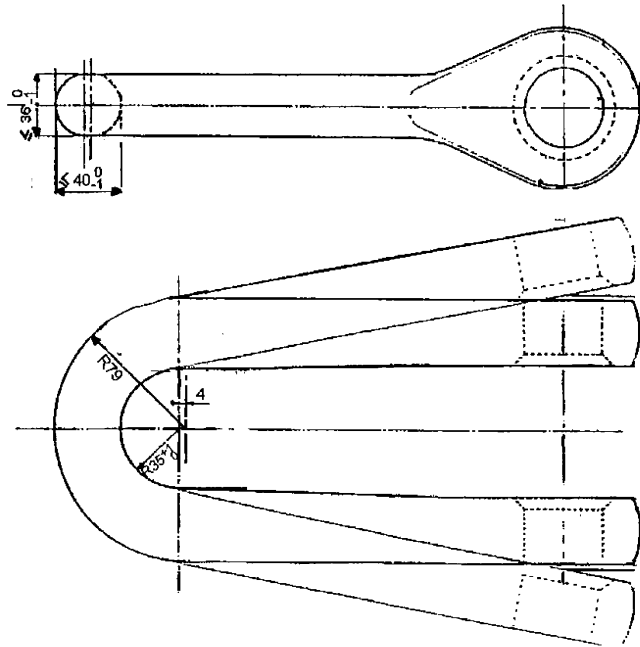
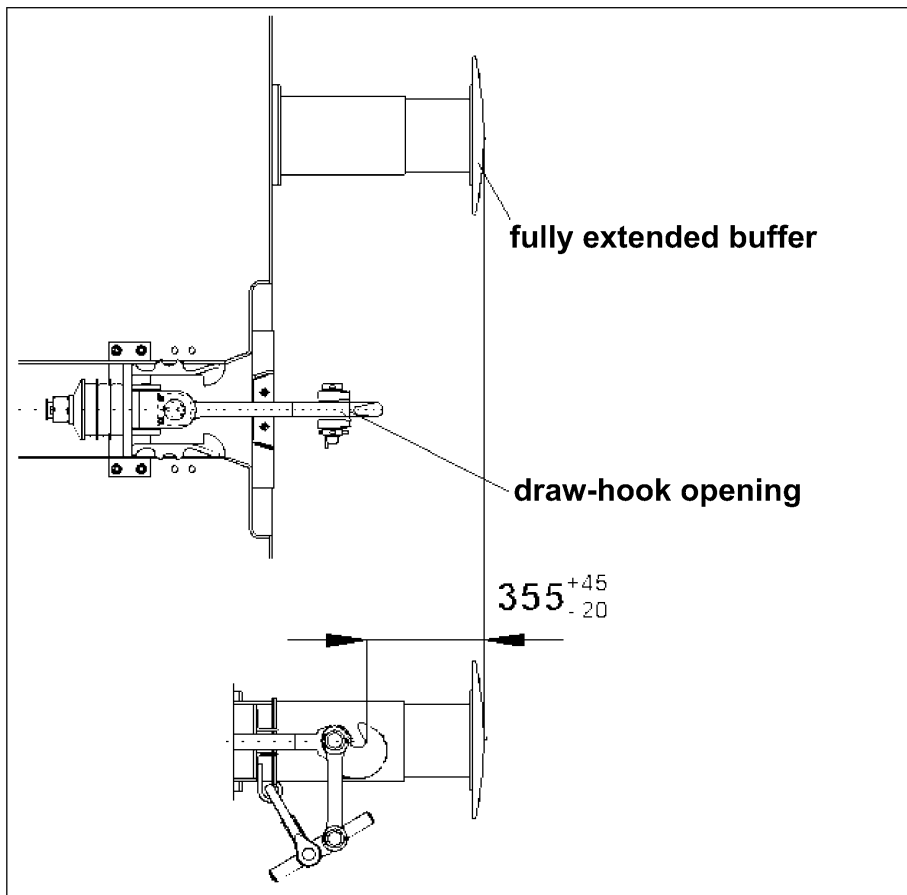

Fig. A4

Draw- and buffing gear



▼B

Fig. A5

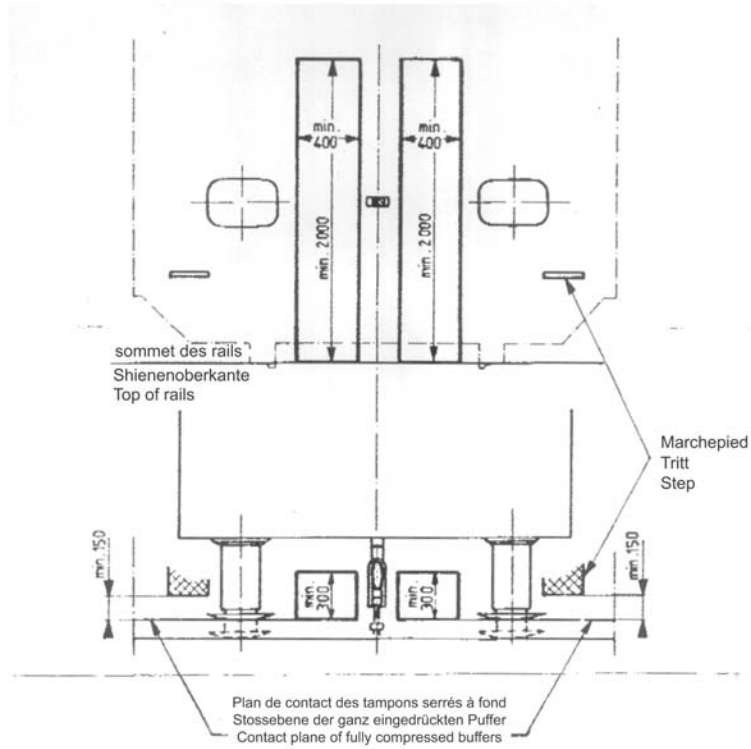
**Berne rectangle**

ESPACES LIBRES A RESERVER AUX EXTREMITES DES VEHICULES  
 FREIZUHALTENDE RÄUME AN DEN WAGENENDEN  
 CLEARANCES TO BE PROVIDED AT VEHICLE EXTREMITIES

▼B

Fig. A6

Screw coupler and draw hooks

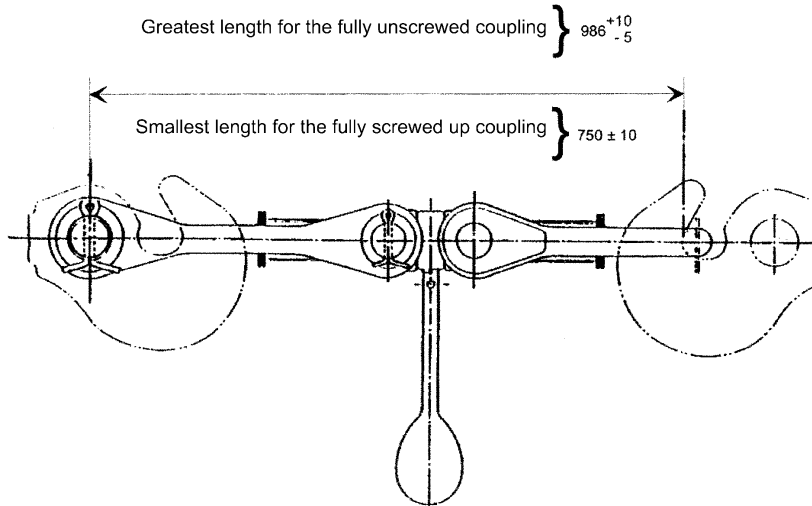
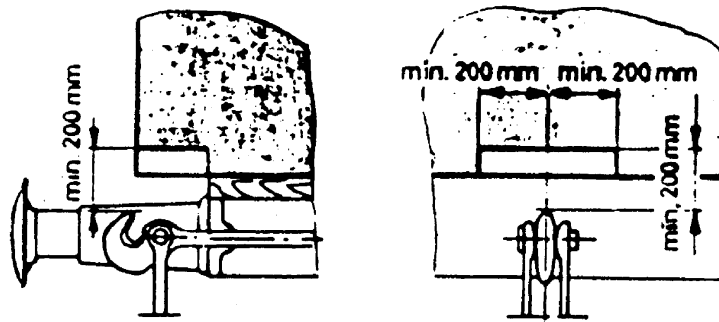

Fig. A7

Clearance to be provided at wagon extremities above the draw hook





## ANNEX B

## STRUCTURES AND MECHANICAL PARTS

## MARKING OF FREIGHT WAGONS

- B.1. VEHICLE UNIQUE NUMBER
- B.2. VEHICLE TARE WEIGHT
- B.3. VEHICLE LOAD TABLE
- B.4. LENGTH OVER BUFFERS
- B.5. SYMBOLS FOR TRAFFIC TO GREAT BRITAIN
- B.6. WAGONS BUILT FOR RUNNING BETWEEN COUNTRIES WITH DIFFERENT TRACK GAUGES
- B.7. AUTOMATIC GAUGE CHANGING WHEELSETS
- B.8. SHUNTING PROHIBITED ON HUMPS WITH A SMALLER CURVE RADIUS THAN THAT SHOWN IN THE DRAWING BELOW
- B.9. BOGIE WAGONS WITH A DISTANCE BETWEEN AXLES IN EXCESS OF 14 000 MM AND WHICH ARE ACCEPTED FOR HUMP SHUNTING
- B.10. WAGONS PROHIBITED FROM PASSING THROUGH RETARDERS OR OTHER STOPPING DEVICES IN SERVICE MODE 9
- B.11. TABLE OF MAINTENANCE DATES
- B.12. HIGH VOLTAGE WARNING NOTICE
- B.13. POSITION OF LIFTING/JACKING POINTS 11
- B.14. MAXIMUM LOAD OF WAGON
- B.15. CAPACITY OF TANK WAGONS
- B.16. CONTAINER WAGON FLOOR HEIGHT
- B.17. MINIMUM CURVE RADIUS
- B.18. SIGN FOR BOGIE WAGONS ONLY PERMITTED TO NEGOTIATE TRAIN-FERRY RAMPS WITH A MAXIMUM RAMP CHANGE ANGLE OF 2°30'
- B.19. MARKINGS ON PRIVATELY OWNED WAGONS
- B.20. MARKINGS ON FREIGHT WAGONS RELATING TO SPECIFIC RISKS ASSOCIATED WITH THE WAGON
- B.21. POSITION OF LOADS: PLATFORM WAGONS
- B.22. DISTANCES BETWEEN OUTER WHEELSETS OR BOGIE CENTRES
- B.23. WAGONS WHICH NEED SPECIAL CARE IN SHUNTING (E.G BI MODAL UNIT)
- B.24. MANUALLY APPLIED PARKING BRAKE
- B.25. INSTRUCTIONS AND SAFETY ADVICES FOR SPECIAL EQUIPMENTS
- B.26. NUMBERING OF WHEELSETS
- B.27. RAKING MARKINGS ON WAGONS
  - B.27.1. *Inscriptions denoting the type of air brake*
  - B.27.2. *Marking of the braked mass on vehicles*
    - B.27.2.1. Vehicles not fitted with changeover devices.
    - B.27.2.2. Vehicles fitted with manual changeover equipment
    - B.27.2.3. Vehicles having two or more sets of brake equipment with separate 'empty-loaded' devices.
    - B.27.2.4. Vehicles fitted with a braking device varying automatically and progressively as the load varies.

**▼B**

- B.27.2.5. Wagons fitted with devices for the automatic control of the 'empty-loaded' apparatus.
- B.27.3. *Others marking concerning the braking*
- B.27.3.1. Marking denoting the installation of a high power R brake system with brake mode 'R'
- B.27.3.2. Marking denoting a brake with composite brake-shoe inserts
- B.27.3.3. Marking denoting disc brakes
- B.28. WAGON WITH AUTOMATIC COUPLER UNDER OSSHD STANDARD
- B.29. PLATE 'PERMISSION TO OPERATE ON 1 520 MM TRACKS'
- B.30. WAGON WITH VARIABLE-GAUGE WHEELSETS (1 435 MM/1 520 MM)
- B.31. MARKING ON BOGIES WITH VARIABLE-GAUGE WHEELSETS (1 435 MM/1 520 MM)
- B.32. MARKING OF WAGONS GAUGE

**▼ B****B.1. VEHICLE UNIQUE NUMBER**

(Location: to the left, on each side)

The vehicle number shall be at least 80 mm in height and shall be located not more than 2 m above rail level. The location of the number shall be such that it is not obscured by any tarpaulin that may be used to sheet the wagon.

Further details are to be found in an EN which has been requested.

**B.2. VEHICLE TARE WEIGHT**

(Location: to the left, on each side)

*Fig. B1*

Tare weight of wagon not fitted with handbrakes.



*Fig. B2*

Marking for the tare weight and braked weight of wagons fitted with handbrakes.

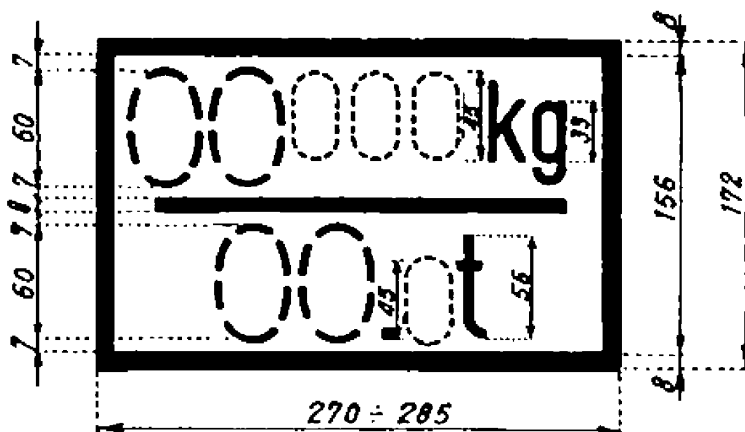

If the Handbrake is ground operated, the latter must be framed in red.

When there are more brakes than 1 fitted on a wagon and acting individually, the number of these brakes is to be shown in front of the braked weight (e.g. 2 x 0,00 t).

**▼B**

B.3. VEHICLE LOAD TABLE

(Location: to the left, on each side)

Fig. B3

	A	B <sub>1</sub>	B <sub>2</sub>	C <sub>2</sub>	C <sub>3</sub>	C <sub>4</sub>	D <sub>2</sub>	D <sub>3</sub>	D <sub>4</sub>
1)	S	00,0	00,0	00,0	00,0	00,0	00,0	00,0	00,0
2)	SS	00,0	00,0	00,0	00,0	00,0	00,0	00,0	00,0

Fig. B4

	A	B	C	D		
1)	S	00,0	00,0	00,0	00,0	★ ★ 5)
3)	120		00,0			

Fig. B5

	A	B <sub>1</sub>	B <sub>2</sub>	C <sub>2</sub>	C <sub>3</sub>	C <sub>4</sub>
2)	SS	00,0	00,0	00,0	00,0	00,0

Meaning of footnotes to the figures:

- 1) Maximum payload in tonnes for wagons in trains worked at up to 100 km/h
- 2) Maximum payload in tonnes for wagons in trains worked at up to 120 km/h
- 3) For wagons able to run at a maximum speed of 120 km/h only when empty

**▼M1**

- 4) Existing wagons that can be forwarded with the same loads as in S-traffic at 120 km/h, are already marked with the sign ‘\*\*\*’, placed to the right of the maximum load markings; no additional wagons can be added to this category
- 5) New wagons with the braking performance of ‘S2’-wagons according to the table in section 4.2.4.1.2.2, that can be forwarded with the same loads as in S-traffic at 120 km/h according to particular specifications listed in Annex Y, shall have the sign ‘\*\*\*\*’ placed to the right of the maximum load markings.

**▼B**

NOTE :

Markings for D line categories may only be placed on wagons in respect of which a higher axle load is allowed for the D category than for the C category.

Fig. B6

Dimensions of Load Table

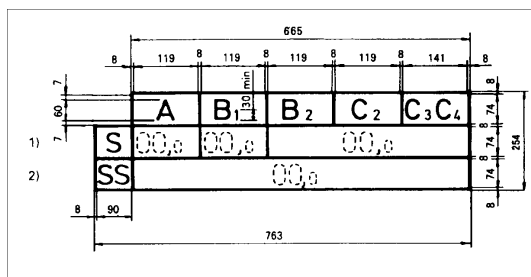



**▼B**

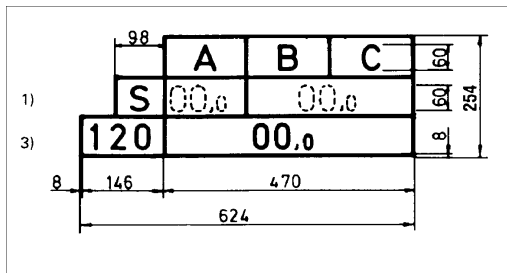

**B.4. LENGTH OVER BUFFERS**

(Location: to the left, on each side)

*Fig. B7*

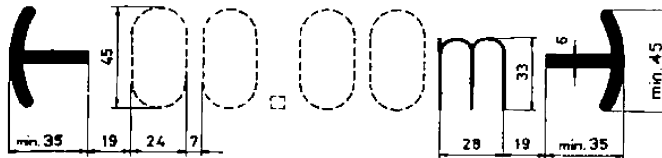

**B.5. SYMBOLS FOR TRAFFIC TO GREAT BRITAIN**

(Location: to the left, on each side)

*Fig. B8*

**for wagons accepted on train-ferries**

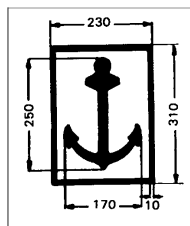

*Fig. B9*

**for wagons accepted through the Channel Tunnel**

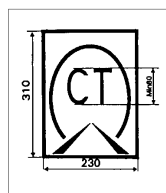

**▼ B**

*Fig. B10*

for wagons accepted on train-ferries and through the Channel Tunnel

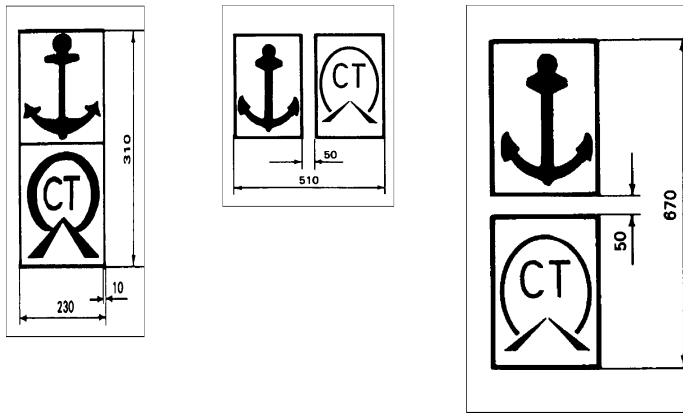

**B.6. WAGONS BUILT FOR RUNNING BETWEEN COUNTRIES WITH DIFFERENT TRACK GAUGES**

(Location: to the right, on each side)

*Fig. B11*

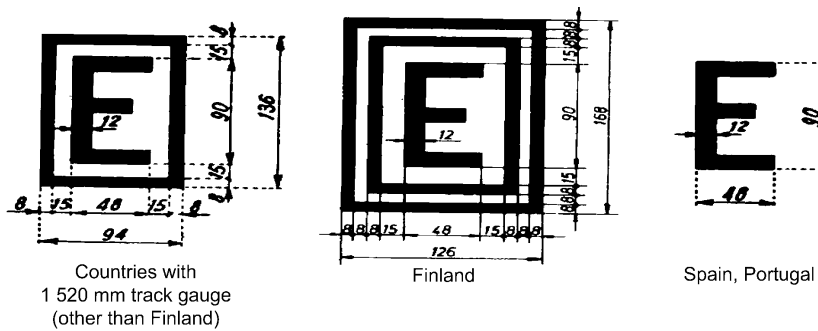

**B.7. AUTOMATIC GAUGE CHANGING WHEELSETS**

(Location: to the right, on each side)

Running gear with automatic gauge-changeover capability for track gauges within the 1 435 mm to 1 668 mm range

*Fig. B12*

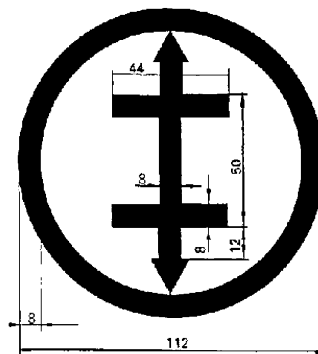

**▼B**

**B.8. SHUNTING PROHIBITED ON HUMPS WITH A SMALLER CURVE RADIUS THAN THAT SHOWN IN THE DRAWING BELOW**

(Location: to the left of each solebar)

*Fig. B13*

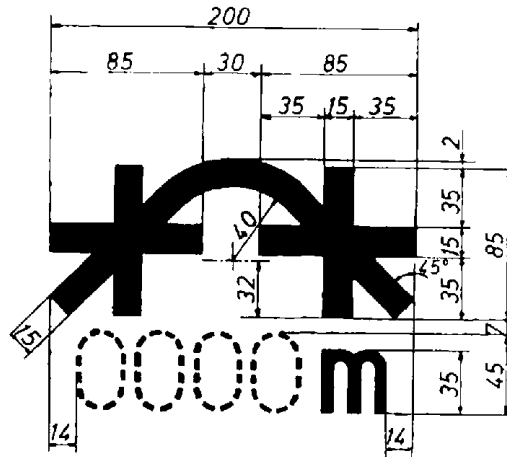

This marking indicates the minimum negotiable hilltop or tub vertical curve radius for wagons which by virtue of their design are liable to sustain damage when passing over humps with a 250m curve radius.

**B.9. BOGIE WAGONS WITH A DISTANCE BETWEEN AXLES IN EXCESS OF 14 000 MM AND WHICH ARE ACCEPTED FOR HUMP SHUNTING**

(Location: to the left of each solebar)

This marking is for bogie wagons with a distance in excess of 14 000mm between two adjacent axles.

It indicates the greatest distance between adjacent axles;

*Fig. B14*

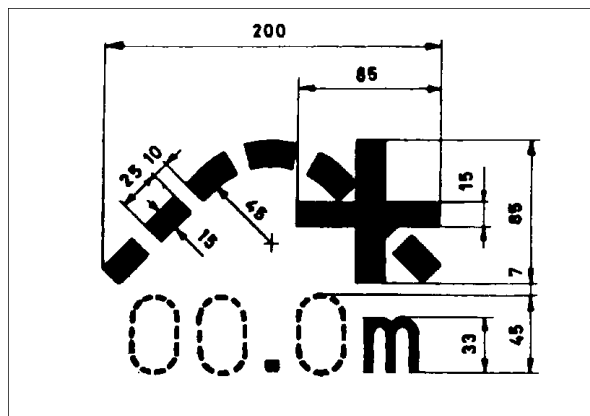

**▼B**

**B.10. WAGONS PROHIBITED FROM PASSING THROUGH RETARDERS OR OTHER STOPPING DEVICES IN SERVICE MODE**

(Location: to the left of each solebar)

*Fig. B15*

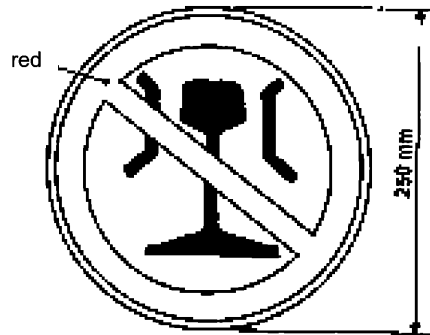

This marking is for wagons which because of their construction must not pass through retarders or other marshalling and braking devices in operational mode.

**B.11. TABLE OF MAINTENANCE DATES**

(Location: to the right of each solebar)

It must be possible, having regard to the maintenance system used, to demonstrate the validity of the data presented on the maintenance plate.

*Fig. B16*

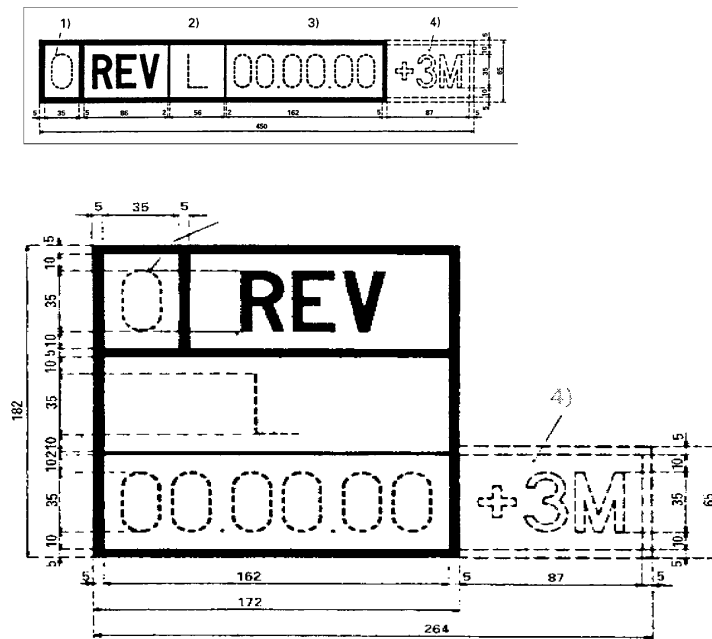

- 1) Maintenance-plate validity period
- 2) Marking of the workshop that takes responsibility for maintenance work, so enabling the validity period to be changed

**▼B**

- 3) Work performance date (day, month, year)
- 4) Additional marking. May only be applied by the owning RU.

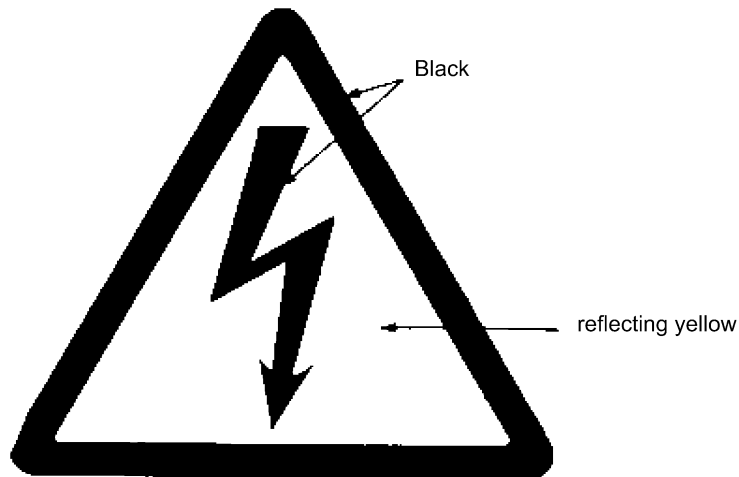
**B.12. HIGH VOLTAGE WARNING NOTICE***Fig. B17***For vehicles built after 1.1.1987**

This marking is located on wagons with footboards placed at a height of over 2 000 mm above rail level or with steps whose end exceeds this dimension adjacent to these fittings. It is positioned so that it becomes visible before the danger zone is actually reached.

**B.13. POSITION OF LIFTING/JACKING POINTS**

This marking is located to the left and to the right on each solebar, level with the lifting points.

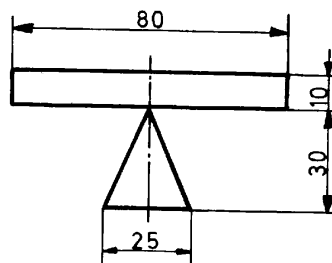
*Fig. B18***Lifting without running gear in workshop.**

▼B

Fig. B19

Lifting at 4 points with or without running gear.

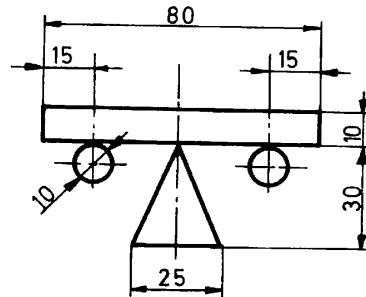
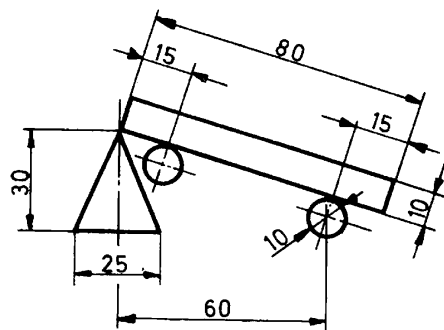

Fig. B20

Lifting with or without running gear or rerailling by only one extremity or close to the extremity.



## B.14. MAXIMUM LOAD OF WAGON

(Location: to the right of each solebar)

This marking is for wagons with a loading capacity in excess of the highest maximum load marked and wagons without maximum-load markings. It indicates the maximum authorised load for the wagon concerned.

Fig. B21

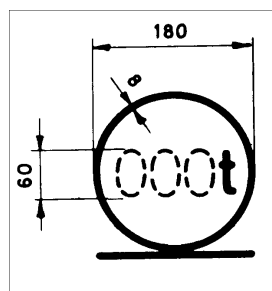

**▼B**

**B.15. CAPACITY OF TANK WAGONS**

(Location: to the left, on each side)

In the case of tank wagons, etc., the capacity in cubic metres, hectolitres, or litres is indicated using the marking as shown below.

*Fig. B22*

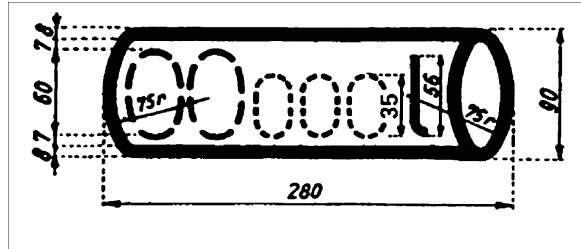

**B.16. CONTAINER WAGON FLOOR HEIGHT**

(Location: to the right, on each side)

*Fig. B23*

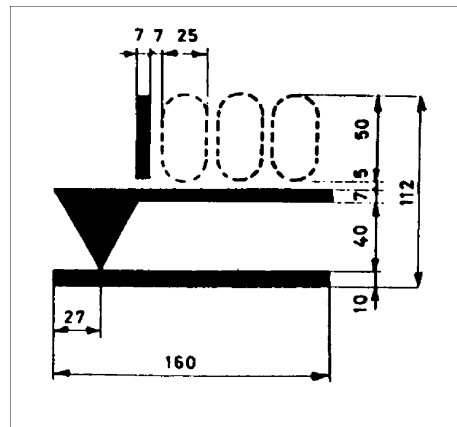

This sign is located on container wagons fit for carrying large containers and/or swap bodies; it indicates the height in mm of the loading plane of the wagon when it is not laden.

**B.17. MINIMUM CURVE RADIUS**

(Location: to the left of each solebar)

This marking is for bogie wagons which are only able to negotiate curves over 35m in radius, indicating the minimum authorised curve radius.

*Fig. B24*

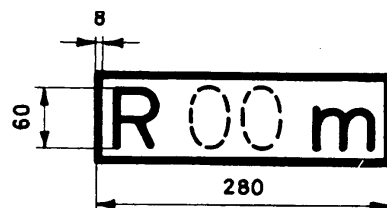

**▼ B****B.18. SIGN FOR BOGIE WAGONS ONLY PERMITTED TO NEGOTIATE TRAIN-FERRY RAMPS WITH A MAXIMUM RAMP CHANGE ANGLE OF 2°30'**

(Location: to the left of each solebar)

This marking is for bogie wagons which can only pass over a train-ferry ramp angle of less than 2°30', indicating the maximum permissible ramp angle for the wagon concerned.

*Fig. B25*

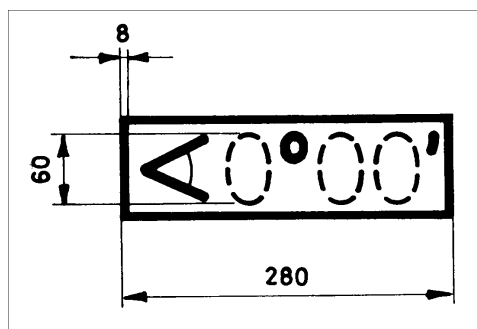
**B.19. MARKINGS ON PRIVATELY OWNED WAGONS**

(Location: to the left, on each side)

Privately owned freight wagons shall be marked with the name and address of the registered keeper.

**B.20. MARKINGS ON FREIGHT WAGONS RELATING TO SPECIFIC RISKS ASSOCIATED WITH THE WAGON**

- (a) In cases where the wagon bodies (superstructures) are liable to move by reference to the underframe (wagons with shock-absorbers, etc.), parts likely to be covered during impact must be painted with diagonal black strips on a yellow background to draw attention to danger areas.
- (b) To avoid possible danger from cable hoods protruding by more than 150 mm, such hooks must be painted as follows:
  - cable hook and protection device: yellow;
  - brackets for cable hooks
  - protruding up to 250 mm: yellow
  - protruding by more than 250 mm: diagonal black strips on yellow background



**▼B**

**B.21. POSITION OF LOADS: PLATFORM WAGONS**

(Location: in the centre of each solebar)

The flat wagons with a usable floor length exceeding 10m, and open high-sided wagons built after 1 January 1968, the maximum height for individual loads distributed over at least three different lengths of supporting surface, must have a marking as shown in Fig. B28 or B29.

This information is optional for all other wagons;

This sign is optional in respect of all other wagons, on which if necessary the sign as shown in Fig. B26 or B27 or B28 or B29, can be affixed.

*Fig. B26*

**Example showing concentrated loads distributed over different lengths of supporting surface and loads resting on two separate supports (bearing width  $\geq 2\text{m}$ )**

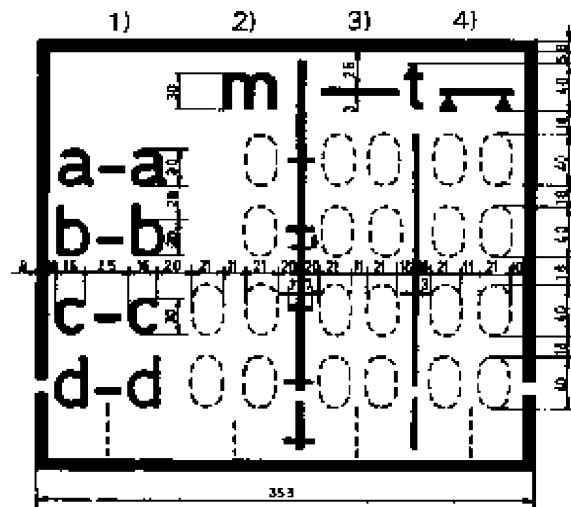
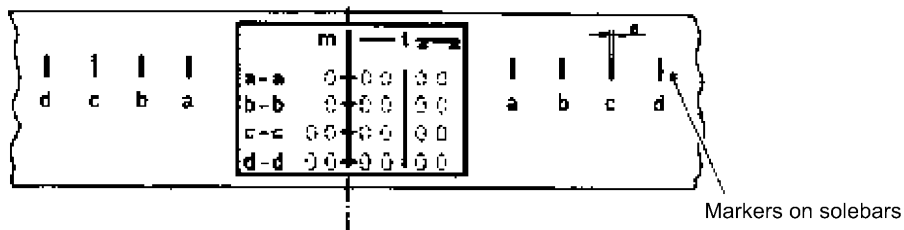

Maximum value for differend lengths:

- of concentrated loads distributed over the lengths of the supporting surfaces
- of loads resting on two supports

- 1) Signs showing the length of the supporting surfaces of concentrated loads, or the distance between the supports.
- 2) Distance in metres between the signs showing the length.
- 3) Maximum tonnages of concentrated loads.
- 4) Maximum tonnages of loads resting on two supports.

**▼B**

Fig. B27

Example showing concentrated loads distributed over different lengths of supporting surface and loads resting on two separate supports (bearing width  $\geq 1,20$  m)

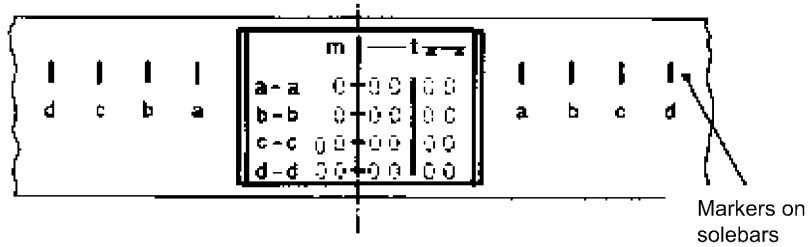

1) 2) 3) 4)

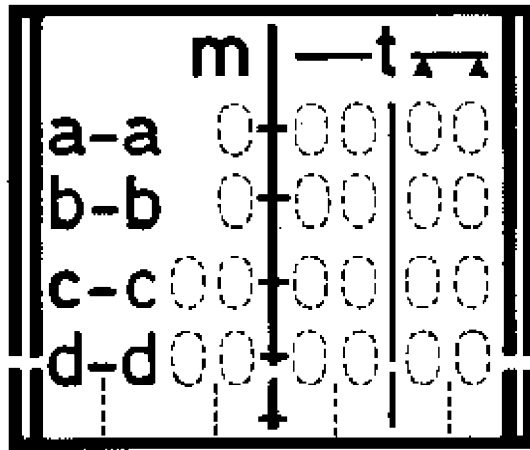

Maximum value, for different lengths:

- of concentrated loads distributed over the lengths of the supporting surfaces
- of loads resting on two supports

- 1) Signs showing the length of the supporting surfaces of concentrated loads, or the distance between the supports.
- 2) Distance in metres between the signs showing the length.
- 3) Maximum tonnages of concentrated loads.
- 4) Maximum tonnages of loads resting on two supports.

**▼ B**

Fig. B28

Example showing concentrated loads distributed over different lengths of supporting surface (bearing width  $\geq 2\text{m}$ )

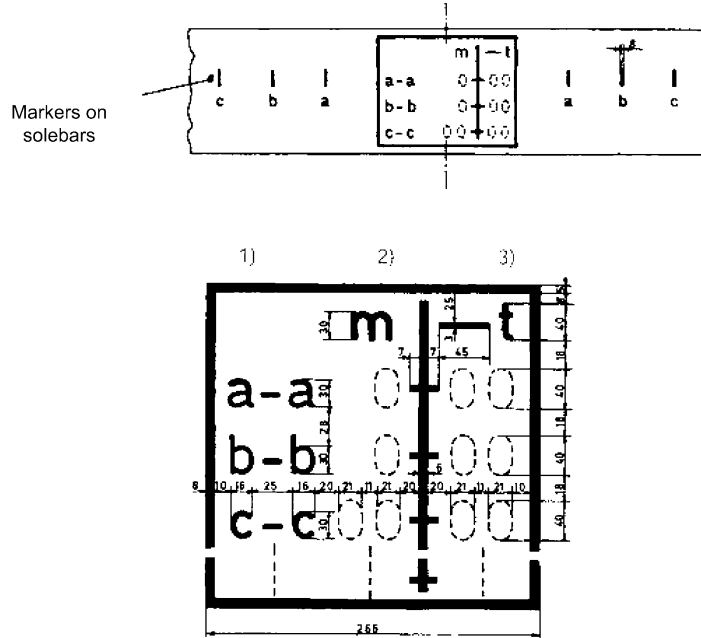

Maximum value for different lengths, of concentrated loads distributed over the lengths of the supporting surfaces

- 1) Signs showing the length of the supporting surfaces of concentrated loads, or the distance between the supports.
- 2) Distance in metres between the signs showing the length.
- 3) Maximum tonnages of concentrated loads.

**▼B**

Fig. B29

Example showing concentrated loads distributed over different lengths of supporting surface (bearing width  $\geq 1,20$  m)

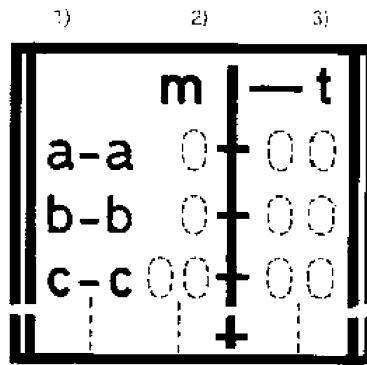
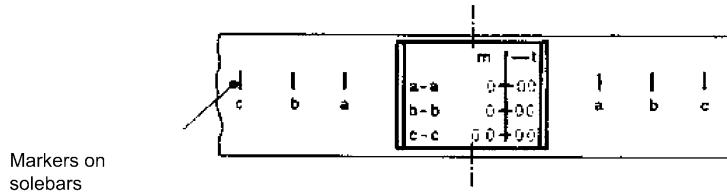

Maximum value, for different lengths, of concentrated loads distributed over lengths of the supporting surfaces **\_\_\_\_\_**

- 1) Signs showing the length of the supporting surfaces of concentrated loads, or the distance between the supports.
- 2) Distance in metres between the signs showing the length.
- 3) Maximum tonnages of concentrated loads.

**B.22. DISTANCES BETWEEN OUTER WHEELSETS OR BOGIE CENTRES**

(Location: to the right of each solebar)

On non-bogie wagons, the distance between end-axles, on bogie wagons the distance between bogie-centres, must be indicated using the marking as shown below.

Fig. B30

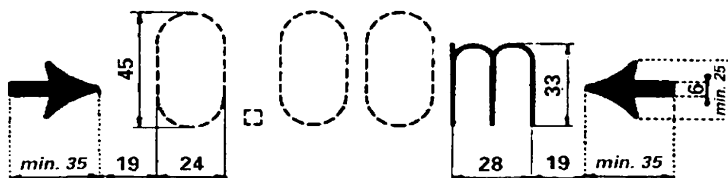

**▼ B****B.23. WAGONS WHICH NEED SPECIAL CARE IN SHUNTING (E.G BI MODAL UNIT)**

On wagons, which need special care in shunting, or end bogies in intermodal traffic, the marking as shown below means that:

- Fly-shunting or gravity-shunting not permitted,
- Must be accompanied by a traction unit,
- Must not be loose-shunted.

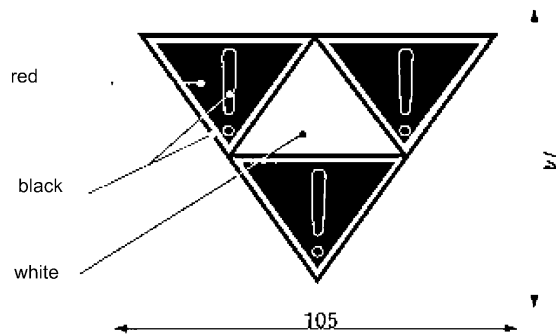
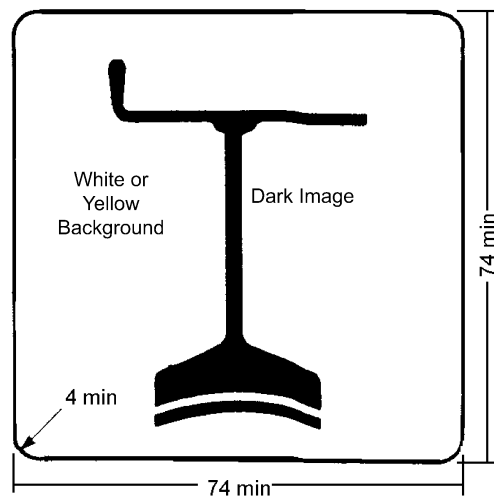
*Fig. B31***B.24. MANUALLY APPLIED PARKING BRAKE***Fig. B32***B.25. INSTRUCTIONS AND SAFETY ADVICES FOR SPECIAL EQUIPMENTS**

Wagons fitted with special equipment (automatic discharging, opening roof, etc.), must have instructions concerning operation of this equipment and the safety precautions to be taken, placed in a prominent position and if possible in several languages; these instructions may be accompanied by appropriate pictograms;

**B.26. NUMBERING OF WHEELSETS**

On the solebar of the wagon, a numerical reference of the axle above each axle-box, corresponding to the position of the axle counted in increasing order from a selected wagon extremity shall be indicated.

**▼ B****B.27. BRAKING MARKINGS ON WAGONS****B.27.1. Inscriptions denoting the type of air brake**

The inscriptions showing the types of continuous brake, to be put on vehicles, must comply with the abbreviated descriptions reproduced below. For the meaning of these brake modes see the TSI, section 4.2.4.1.2.2.

Brake mode	G
Brake mode	P
Brake mode	R
GP changeover system (or device)	GP
PR changeover system (or device)	PR
G/P/R changeover system (or device)	GPR
Braking device varying automatically and progressively in relation to the load	A

**B.27.2. Marking of the braked mass on vehicles**

In the following figs the letter 'x' corresponds to the mass and the letter 'y' to the changeover braked mass. The letter  $x$  in a frame corresponds to the variable braked mass which are shown in the windows.

**B.27.2.1. Vehicles not fitted with changeover devices.**

The braked mass shall be inscribed on the solebars near the inscription of the braking system as shown in Fig. B33.

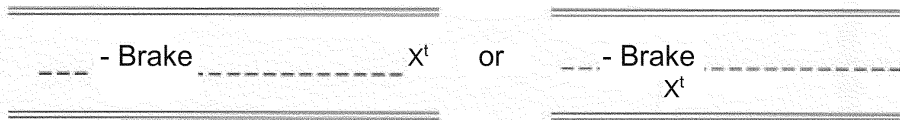
*Fig. B33***B.27.2.2. Vehicles fitted with manual changeover equipment**

— 'Freight-passenger' G/P changeover equipment

In the case of vehicles fitted with 'freight-passenger' G/P changeover equipment, the changeover from one system to another must be made using a lever with end-knob as shown in Fig. B34.

In the 'freight' G braking mode, the lever must slope upwards to the left.

In the 'passenger' P braking mode, the lever must slope upwards to the right.

The braked masses are inscribed on the plate behind the changeover lever, beside each lever position when in 'goods' G or 'passenger' P.

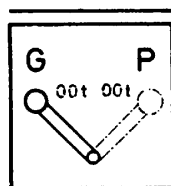
*Fig. B34*

— Vehicles fitted with an 'empty-loaded' changeover device.

The braked masses and changeover masses shall be inscribed on the 'empty-loaded' changeover plates. The braked masses shall not be inscribed close to the levers of other changeover devices.

**▼ B**

If there are only the ‘empty-loaded’ changeover and solely two positions of the reversing lever (the ‘empty’ braking system and one ‘loaded’ braking system only), the braked masses must be shown on a plate in front of which the lever moves, on the right and left of the plate axis, close to the corresponding position of this lever. The changeover mass must be shown under the lever axis or between the two braked masses mentioned above. (see Fig. B35).

Fig. B35

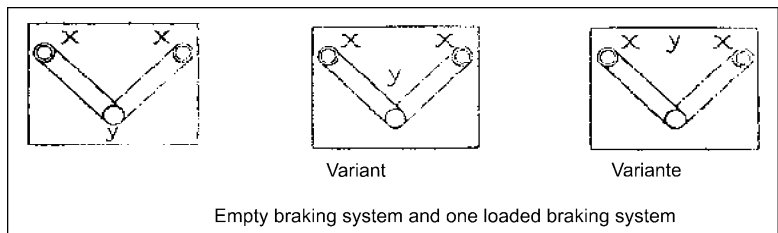

If there is the ‘empty-loaded’ changeover alone and several positions of the lever (the ‘empty’ braking system and several ‘loaded’ braking systems) the braked mass corresponding to each position of the lever is inscribed in a window, fitted at the top, in the middle of the plate behind which the lever moves. (see Fig. B36).

Fig. B36

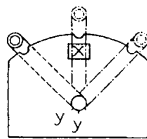

It is also possible to use the device given in Fig. B37, in which the braked masses are permanently inscribed beside each position of the lever.

Fig. B37

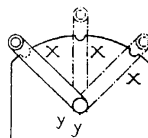

The changeover masses shall be inscribed on the plate under the lever axis. A pointer fixed on the lever, which moves in front of the plate, shows, for each position of the lever, the corresponding changeover mass. (see Fig. B36 and B37).

**B.27.2.3. Vehicles having two or more sets of brake equipment with separate ‘empty-loaded’ devices.**

On both plates of each ‘empty-loaded’ device shall be inscribed the braked mass relative to the part of the equipment controlled by this device and the changeover mass corresponding to the whole vehicle according to B.27.2.2.

**B.27.2.4. Vehicles fitted with a braking device varying automatically and progressively as the load varies.**

These vehicles shall bear an inscription, similar to that shown in Fig. B38 in the vicinity of each lever.

▼ **B**

Fig. B38

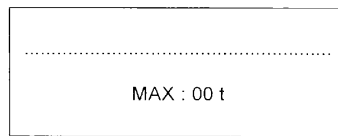

On vehicles with more than one distributor (e.g. multiple wagons), the braked mass obtained for each distributor shall be entered in brackets after the total braked mass (e.g. for three distributors: MAX 203t (80t + 43t + 80t)).

Each distributor isolating cock shall carry details of the brake mass corresponding to the distributor in question as well as the symbol denoting 'pneumatic brake in use'; see Fig. B39.

Fig. B39



In addition, the braked axle numbers assigned to the distributor isolating cock shall be entered in a frame; see Fig B40.

Fig. B40

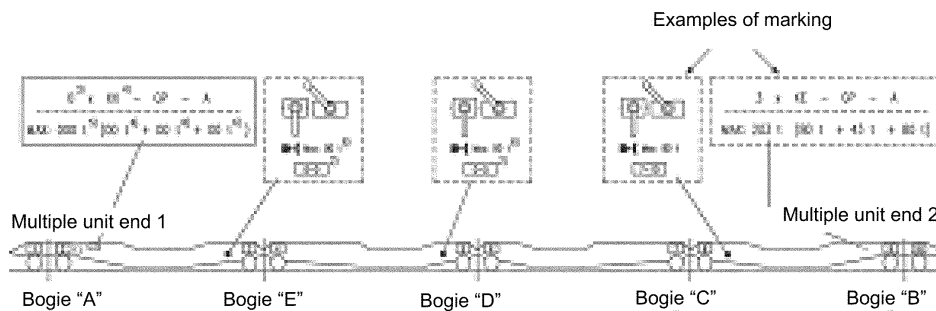

- 1) Marking of the axles numbering above the axle on the solebar on both sides of the vehicle
- 2) Marking of the axles assigned to this braking system immediately below the braked mass inscription of this system
- 3) Number of distributors for the entire multiple unit
- 4) Optional
- 5) Maximum obtainable braked mass (sum of all braked masses)
- 6) Braked mass of a braking system

#### B.27.2.5. Wagons fitted with devices for the automatic control of the 'empty-loaded' apparatus.

The braked masses and the changeover mass shall be inscribed on a special panel or on the sole bar:

at the top, on the left: the braked mass of the empty wagon,

at the top, on the right: the braked mass of the loaded wagon,

at the bottom, in the middle: the changeover mass.

Wagons with braked masses in the 'freight' G position which differ from those in the 'passenger' P position, shall bear a full inscription close to the two positions of the 'G-P' changeover lever; see Fig B41.



**▼B**

Fig. B41

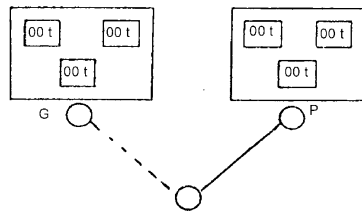

Wagons with identical braked masses in the 'freight' G position and in the 'passenger' P position, shall bear the inscriptions as shown in Fig. B42 close to the 'G-P' changeover lever.

Fig. B42

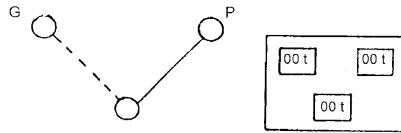

Wagons with only the 'freight' G position or the 'passenger' P position shall be marked as shown in Fig. B43.

Fig. B43

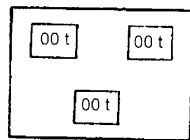

**B.27.3. Others marking concerning the braking**

The following markings must be located in the centre of each solebar.

**B.27.3.1. Marking denoting the installation of a high power R brake system with brake mode 'R'**

Fig. B44

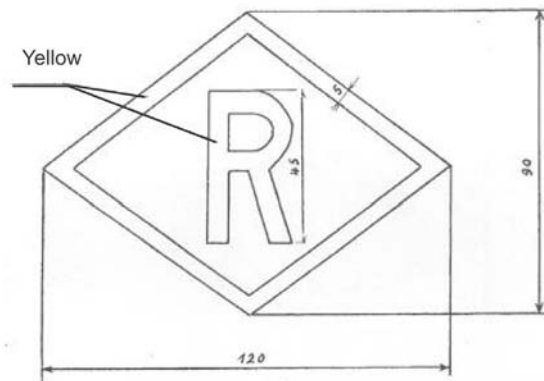

**▼B**B.27.3.2. *Marking denoting a brake with composite brake-shoe inserts*

Fig. B45

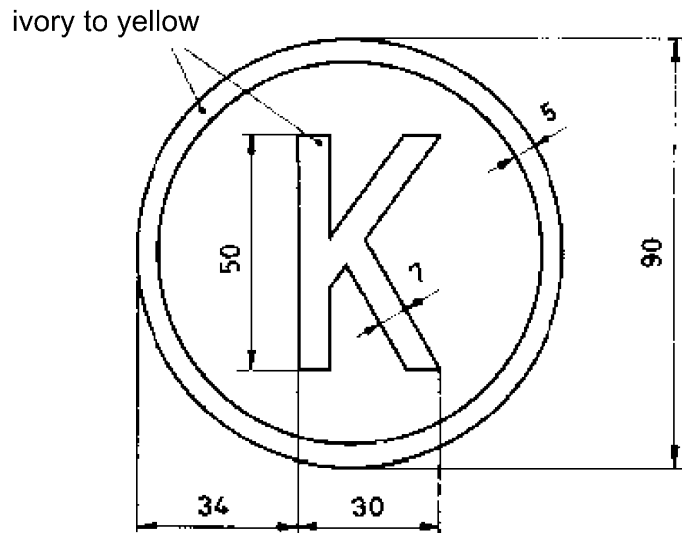
B.27.3.3. *Marking denoting disc brakes*

The instructions for checking the condition of the brakes must be indicated.

Fig. B46

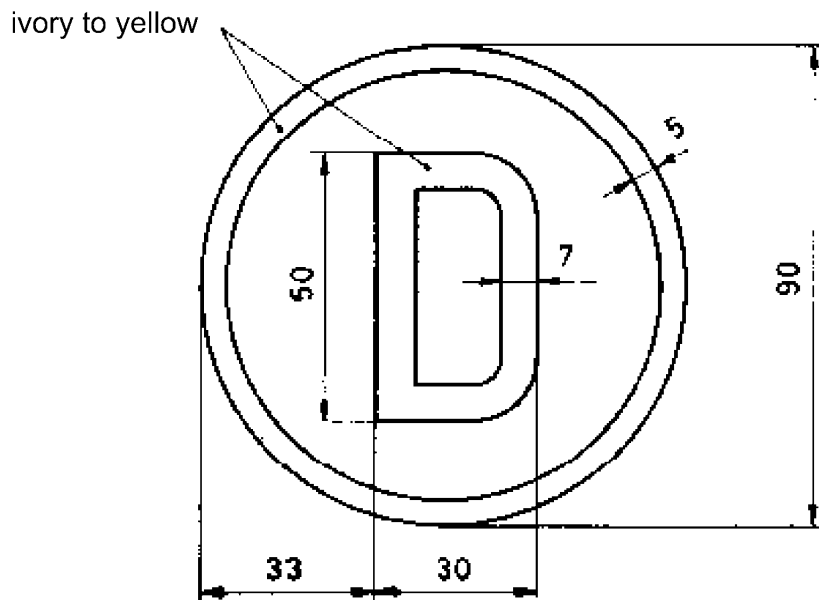

**▼ B**

**B.28. WAGON WITH AUTOMATIC COUPLER UNDER OSSHD STANDARD**

*Fig. B47*

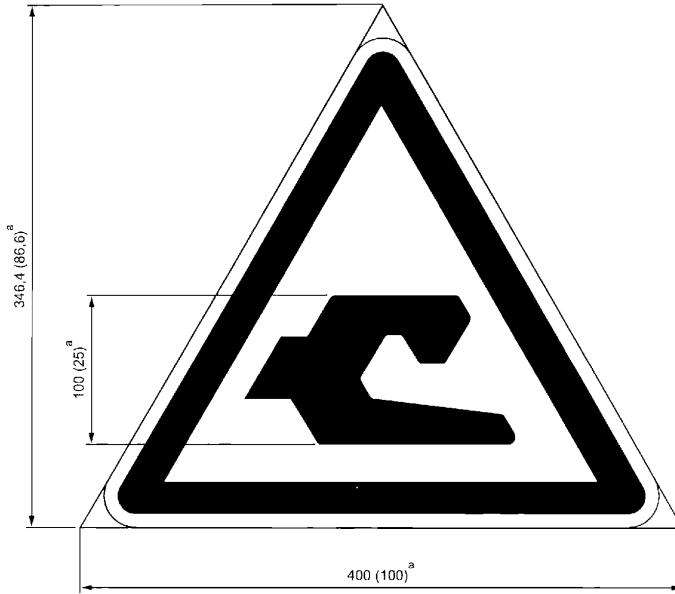

**B.29. PLATE 'PERMISSION TO OPERATE ON 1 520 MM TRACKS'**

*Fig. B48*

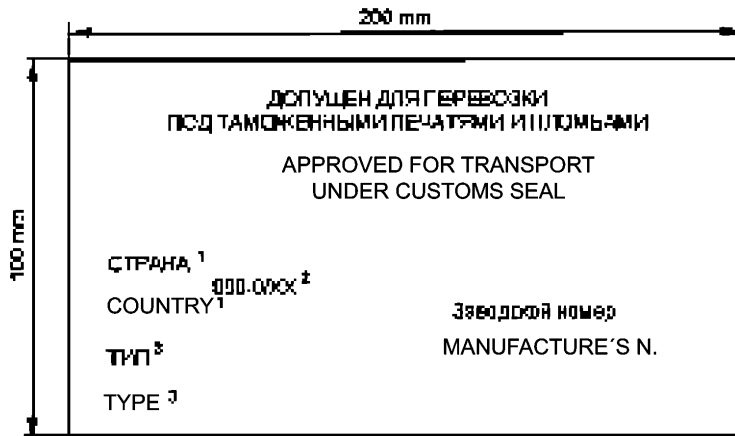

**▼ B**

**B.30. WAGON WITH VARIABLE-GAUGE WHEELSETS (1 435 MM/1 520 MM)**

*Fig. B49*

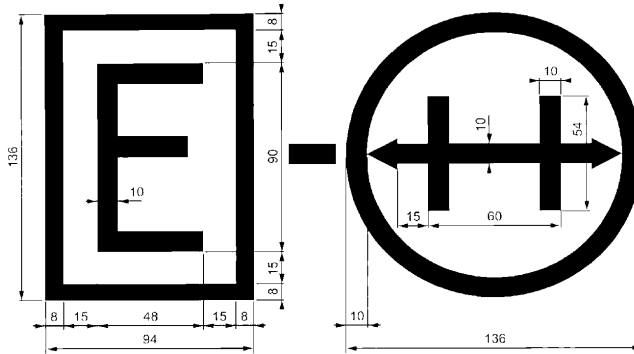

**B.31. Marking on bogies with variable-gauge wheelsets (1 435 mm/1 520 mm)**

*Fig B50*

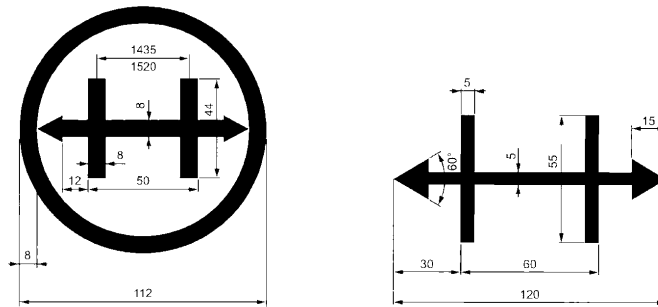

**▼ M1**

**B.32. MARKING OF WAGONS GAUGE**

(1) Wagons built to gauge G1 will be marked as follows:

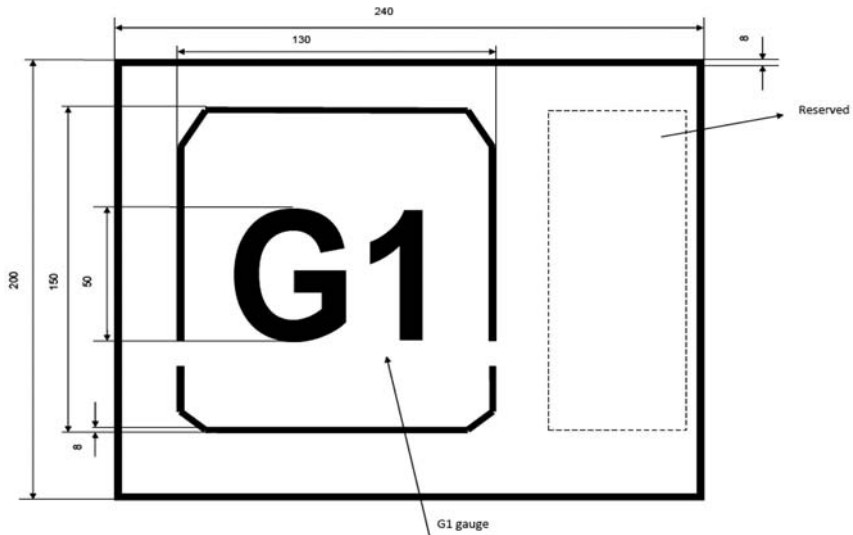

**▼ M1**

- (2) Wagons built to gauges GA, GB or GC will be marked as follows:

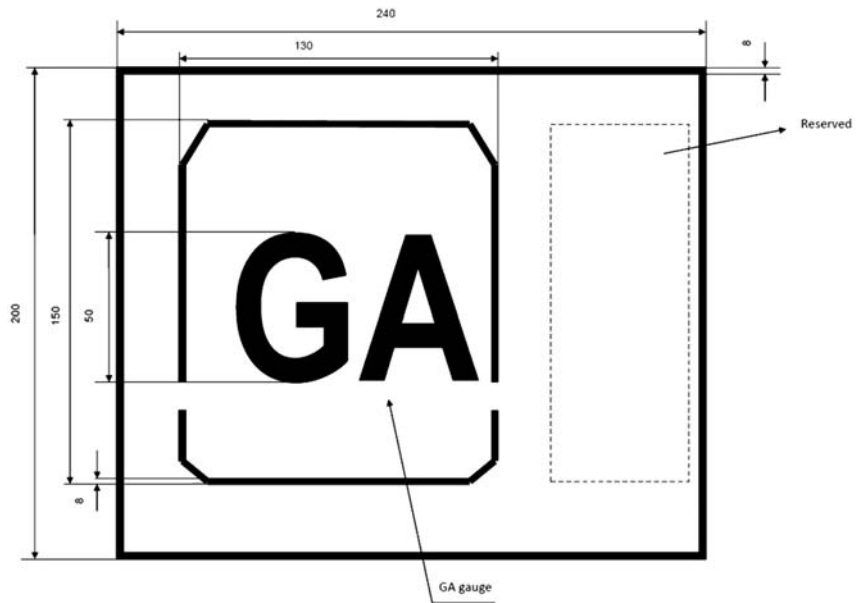



*ANNEX C*

**VEHICLE TRACK INTERACTION AND GAUGING**

**Kinematic Gauge**

- C.1. SCOPE OF APPLICATION
  - C.2. GENERAL PART
    - C.2.1. List of notations used
    - C.2.2. Definitions
      - C.2.2.1. Normal co-ordinates
      - C.2.2.2. Reference profile
      - C.2.2.3. Geometric overthrow
      - C.2.2.4. Roll centre C
      - C.2.2.5. Asymmetry
      - C.2.2.6. Maximum construction gauge for rolling stock
      - C.2.2.7. Kinematic gauge
      - C.2.2.8. Quasi-static movements z
      - C.2.2.9. S projections (Fig.C5)
      - C.2.2.10. Ei or Ea reductions
      - C.2.2.11. Lineside structure gauge
    - C.2.3. General comments on the method for obtaining the maximum rolling stock construction gauge
      - C.2.3.1. Relative positions of the various gauges
    - C.2.4. Rules for the reference profile for determining the maximum rolling stock construction gauge
      - C.2.4.1. Vertical movements
        - C.2.4.1.1. Determination of minimum heights above the running surface
        - C.2.4.1.2. Passing over vertical transition curves (including marshalling yard humps) and over braking, shunting or stopping devices.
        - C.2.4.1.3. Determination of maximum heights above the running surface
      - C.2.4.2. Lateral movements (D)
        - C.2.4.2.1. Vehicle running position on the track and displacement factor (A)
          - C.2.4.2.2. Special cases of multiple units and coaches fitted with a reversing cab (driving trailer)
            - C.2.4.2.3. Quasi-static movement (z)
    - C.2.5. Determination of reductions by calculation
      - C.2.5.1. Terms taken into account in calculating movements (D)
        - C.2.5.1.1. Terms concerning the running position of the vehicle on a curve (geometric overthrow)
          - C.2.5.1.2. Group of terms concerning lateral play
            - C.2.5.1.3. Quasi-static movements (term concerning vehicle[s] inclination [leaning] on its suspension and its asymmetry when this is greater than 1°)
- C.3. GAUGE G1
  - C.3.1. Reference profile for static gauge G1
    - C.3.1.1. Reduction formulae
  - C.3.2. Reference profile for kinematic gauge G1
    - C.3.2.1. Part common to all vehicles
    - C.3.2.2. Part below 130 mm on vehicles which must not pass over shunting humps or negotiate rail brakes and other activated shunting and stopping devices

**▼B**

- C.3.2.3. Part below 130 mm for vehicles able to pass over shunting humps and negotiate rail brakes and other activated shunting and stopping devices
  - C.3.2.3.1. Use of shunting devices on curved track sections
- C.3.3. Permitted projections  $S_0$  (S)
- C.3.4. Reduction formulae
  - C.3.4.1. Reduction formulae applicable to powered vehicles (dimensions in metres)
  - C.3.4.2. Reduction formulae applicable to multiple units (dimensions in metres)
  - C.3.4.3. Reduction formulae applicable to coaches and passenger vehicles (dimensions in metres)
  - C.3.4.4. Reduction formulae applicable to wagons (dimensions in metres)
- C.3.5. Reference profile for pantographs and non-insulated live parts on the roof
- C.3.6. Rules for the reference profile for determining the maximum rolling stock construction gauge
  - C.3.6.1. Powered units fitted with pantographs
  - C.3.6.2. Railcars fitted with pantographs
  - C.3.6.3. Pantographs in lowered position
  - C.3.6.4. Insulation clearance margin for 25kV
- C.4. GA, GB, GC VEHICLE GAUGES
  - C.4.1. Static gauge reference profiles and associated rules
    - C.4.1.1. GA and GB static gauges
    - C.4.1.2. GC static gauge
  - C.4.2. Kinematic gauge reference profiles and associated rules
    - C.4.2.1. Tractive units (except railcars and multiple unit motor coaches)
      - C.4.2.1.1. GA and GB kinematic gauges
      - C.4.2.1.2. GC kinematic gauge
    - C.4.2.2. Railcars and multiple unit motor coaches
      - C.4.2.2.1. GA and GB kinematic gauges
      - C.4.2.2.2. GC kinematic gauge
    - C.4.2.3. Passenger coaches and luggage vans
      - C.4.2.3.1. GA and GB kinematic gauges
      - C.4.2.3.2. GC kinematic gauge
    - C.4.2.4. Wagons
      - C.4.2.4.1. GA and GB kinematic gauges
      - C.4.2.4.2. GC kinematic gauge
- C.5. GAUGES REQUIRING BI- OR MULTILATERAL AGREEMENTS
  - C.5.1. G2 gauge
    - C.5.1.1. Reference profile of G2 static gauge
    - C.5.1.2. Reference profile of G2 kinematic gauge
  - C.5.2. GB1 and GB2 gauges
    - C.5.2.1. General
    - C.5.2.2. GB1 and GB2 static reference profiles (loading gauges)
    - C.5.2.3. Rules for GB1 and GB2 static reference profiles
    - C.5.2.4. GB1 and GB2 kinematic reference profiles
    - C.5.2.5. Rules for GB1 and GB2 kinematic reference profiles
  - C.5.3. Gauge 3.3
    - C.5.3.1. General

**▼ B**

- C.5.3.2. Reference profile of 3.3 kinematic gauge
- C.5.3.3. Rules for the reference profile to determine the maximum construction gauge
  - C.5.3.3.1. Permitted projections  $S_0$  (S)
  - C.5.3.3.2. Quasi-static displacements  $z$
- C.5.3.4. Reduction formulae
  - C.5.3.4.1. Reduction formulae applicable to tractive units (dimensions in metres)
  - C.5.3.4.2. Reduction formulae applicable to multiple units (dimensions in metres)\*
  - C.5.3.4.3. Reduction formulae applicable to coaches and other passenger vehicles (dimensions in metres)
- C.5.4. Gauge GB-M6
  - C.5.4.1. General
  - C.5.4.2. Reference profile of the GB-M6 kinematic gauge
  - C.5.4.3. Reduction formulae
    - C.5.4.3.1. Tractive vehicles
    - C.5.4.3.2. Hauled vehicles
- C.6. APPENDIX 1
  - C.6.1. Rolling Stock Loading Gauge
    - C.6.1.1. Conditions concerning doors, steps and footboards
- C.7. APPENDIX 2
  - C.7.1. Rolling Stock Loading Gauge
    - C.7.1.1. Compression of the suspensions for areas outside the support polygon B, C and D
- C.8. APPENDIX 3 ROLLING STOCK LOADING GAUGE
  - C.8.1. Calculation of the loading gauge of tilting vehicles
    - C.8.1.1. General
    - C.8.1.2. Scope
    - C.8.1.3. Field of application
    - C.8.1.4. Background
    - C.8.1.5. Conditions related to safety
    - C.8.1.6. Symbols used
  - C.8.2. Basic conditions to determine the loading gauge of TBV units
    - C.8.2.1. Types of body tilting systems
  - C.8.3. Analysis of the formulae
    - C.8.3.1. Basic formulae
    - C.8.3.2. Modifications to be made to the formulae for TBVs
      - C.8.3.2.1. Expression for the values of the lateral plays when the body is tilted
      - C.8.3.2.2. Quasi-static displacement of a TBV
        - C.8.3.2.2.1. Expression of the quasi-static displacements  $z_P$  for the reductions on the inside of the curve
        - C.8.3.2.2.2. Expression of the quasi-static displacements  $z_P$ , for the reductions on the outer side of the curve
      - C.8.3.2.3. ACTIVE systems: displacements due to body rotation
  - C.8.4. Associated Rules
  - C.8.5. Comments
    - C.8.5.1. Condition for adjusting the inclination (TBV units with active system)
    - C.8.5.2. Condition concerning the speed of TBV units
  - C.8.6. Appendix 4 Rolling Stock Loading Gauge



**▼ B**

## C.1. SCOPE OF APPLICATION

The loading gauges available in different countries are classified as follows:

- Gauge allowed with no restriction: G1
  - The target gauge, available on all lines (except the UK, see Annex T)
- Gauge whose free use is limited to certain, precisely specified routes: Gauges GA, GB, GC
- Gauges the use of which must be covered by a prior agreement between the Infrastructure Managers concerned: Gauges G2, 3.3, GB-M6, GB1, GB2, etc.
- Loads carried on wagons
  - For the loads carried on wagons, only the load profiles and the loading methods set down in Appendix 6 shall be accepted.
- Combined transport
  - For the requirements of combined transport traffic, using load units of well-defined volume (swap bodies, containers and semi-trailers) on specified wagons (Ref. PTU chapter 3.2.1).
- Interoperable high-speed vehicles.
  - The vehicles of high-speed trainsets that are interoperable within the European Community shall be built to the loading gauges prescribed in Section 4.1.4 of the Rolling Stock TSI.
- Rolling stock equipped with cant deficiency compensation systems
  - Such rolling stock shall be checked by the method set down in Appendix 3.
- Pantographs
  - The space envelope of the pantographs and roof-mounted equipment shall be checked according to Chapter 4.2.2.5.
- *OSSJD loading gauges*
  - OSSJD member states use particular loading gauges. As soon as the technical and application documents become available, the corresponding text shall be the subject of Appendix 7
- Doors and steps
  - The rules pertaining to doors and steps are set down in Appendix 1.
- Compression of suspensions for the zones located outside the support polygon B — C — D
  - The rules are given in Appendix 2.
- Utilisation of the existing margins available on the infrastructure by vehicles with defined parameters
  - Such rolling stock shall be checked by the method given in Appendix 4.

## C.2. GENERAL PART

## C.2.1. List of notations used

- A : angular displacement coefficient of bogie
- a : distance between the end axles of vehicles not fitted with bogies or between the pivots of bogie vehicles (see Note)
- b : half width of the vehicle (see diagram in Appendix 2)
- b1 : half distance between the primary suspension springs (see diagram in Appendix 2)
- b2 : half distance between the secondary suspension springs (see diagram in Appendix 2)
- bG : half distance between the side-bearers

**▼B**

bw	: half width of the pantograph bow
C	: roll centre (see Figure 3)
d	: the outer distance between the wheel flanges measured at a point 10 millimetres below the running treads, with the flanges worn to the permissible limit, the absolute limit being 1,410 m. This limit may vary according to the maintenance criteria for the vehicle under consideration
dga	: outer curve overthrow
dgi	: inner curve overthrow
D	: lateral movement
Ea	: external reduction
Ei	: internal reduction
E'a	: external deviation in relation to the movement authorised at the pantograph upper verification point (6,5 m)
E'i	: internal deviation in relation to the movement authorised at the pantograph upper verification point (6,5 m)
E'a	: external deviation in relation to the movement authorised at the pantograph lower verification point (5,0 m)
E'i	: internal deviation in relation to the movement authorised at the pantograph lower verification point (5,0 m)
ea	: external vertical reduction at the lower part of vehicles
ei	: internal vertical reduction at the lower part of vehicles
f	: vertical sag (see Appendix 2)
h	: height in relation to the running surface
hc	: height of the roll centre of the transverse cross-section of the vehicle in relation to the running surface
ht	: installation height of the pantograph lower articulation in relation to the running surface
J	: side-bearers play
J'a, J'i	: difference between the movements resulting from the calculation and movements due to play effects
l	: track gauge
n	: distance between the section considered and the adjacent end axle or nearest pivot (see Note)
na	: n for the sections located outside the axles or bogie pivots
ni	: n for the sections located between the axles or bogie pivots
n <sub>μ</sub>	: distance of the section considered to the motor bogie pivot of multiple units (see Note)
p	: bogie wheel base
p'	: trailer bogie wheel base for multiple units
q	: lateral play between axle and bogie frame or between axle and vehicle body in the case of axle vehicles
R	: level curve radius
R <sub>v</sub>	: vertical curve radius
s	: vehicle flexibility coefficient
S	: projection
So	: maximum projection

**▼ B**

- t : pantograph flexibility index: lateral movements expressed in metres to which the bow is subjected when raised to 6,50 m under the effect of a 300 N lateral force
- w : lateral play between bogie and vehicle body
- $w_{\infty}$  : lateral play between the bogie and the vehicle body on straight track
- w<sub>a</sub> : lateral play between the bogie and vehicle body on the outside of the curve
- w<sub>i</sub> : lateral play between the bogie and vehicle body on the inside of the curve
- w<sub>a</sub>(R) : lateral play between the bogie and vehicle body on the outside of an R radius curve
- w<sub>i</sub>(R) : lateral play between the bogie and vehicle body on the inside of an R radius curve
- $w'_{\infty}$  —  $w'_a$  —  $w'_i$  —  $w'_a$ (R) —  $w'_i$ (R) are the same for the trailer bogies of multiple units.
- x<sub>a</sub> : additional reduction for extra-long vehicles outside the bogie pivots
- x<sub>i</sub> : additional reduction for extra-long vehicles between the bogie pivots
- y : distance from the effective pivot to the geometric centre of the bogie (see Note)
- z : deviation in relation to the median position due to quasi-static inclination and to dissymetry
- z' : difference between the lateral inclination based on calculation and the actual inclination of the pantograph upper verification point
- z'' : difference between the lateral inclination based on calculation and the actual inclination of the pantograph lower verification point
- α : additional vehicle body inclination due to side-bearers play
- δ : inclination of canted track (see figure 3)
- η<sub>0</sub> : angle of vehicle asymmetry due to construction tolerances, to suspension adjustment and to uneven load distributions (in degrees)
- θ : suspension adjustment tolerance: inclination which the vehicle body may attain as a result of suspension adjustment imperfections when the vehicle is resting empty on level track (in radians)
- μ : rail-wheel adhesion coefficient
- τ : pantograph construction and installation tolerance: deviation tolerated between the vehicle body centre line and the middle of the bow presumed to be raised to 6,5 m without any lateral stress

**Note** : In the case of vehicles without fixed bogie pivots, in order to determine the a and n values, the meeting point of the bogie longitudinal centre line with that of the vehicle body will be considered as a fictional pivot, determined graphically, when the vehicle is on a 150 m radius curve, the play effects being evenly distributed and the axles centred on the track: if y is the distance of the fictional pivot from the geometric centre of the bogie (at equal distance from the end axes),  $p^2$  will be replaced by  $(p^2 - y^2)$  and  $p'^2$  by  $(p'^2 - y^2)$  in the formulae.

## C.2.2. Definitions

### C.2.2.1. Normal co-ordinates

The expression 'normal co-ordinates' is used for orthogonal axes defined in a plane normal to the centreline of the track in nominal position; one of these axes, sometimes called horizontal, is the intersection of the specified plane and the running surface; the other is the perpendicular to this intersection at equal distance from the rails.

▼ B

For calculation purposes, this centreline and the vehicle centreline must be considered as coincident in order to be able to compare the vehicle construction gauges and the lineside structure limit gauges, both calculated on the basis of the kinematic gauge reference profile which is common to both.

Fig. C1

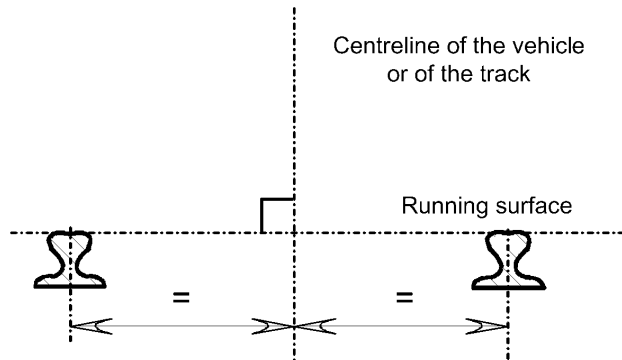

## C.2.2.2. Reference profile

Profile related to the normal co-ordinates, always accompanied by associated rules used, for rolling stock, to define the vehicle maximum construction gauge.

## C.2.2.3. Geometric overthrow

The expression geometric overthrow means, for an element of a vehicle located on a radius  $R$  curve, the difference between the distance from this element to the track centreline and that which would exist on straight track, the axles being, in both cases, placed in a median position on the track, the play also being evenly distributed, the vehicle symmetrical and not tilted on its suspensions; in other words, it is that part of the vehicle element offset which is due to the track curvature.

On the same side of the track centreline, all the points in the same vehicle body cross-section have the same geometric overthrow.

Fig. C2

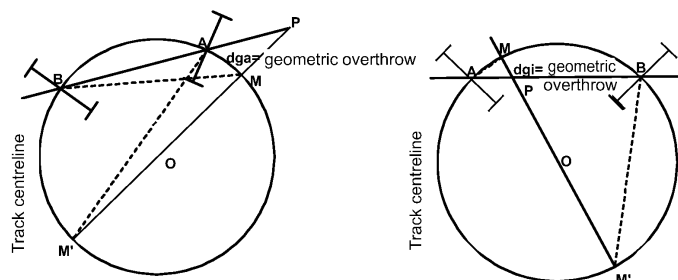

## C.2.2.4. Roll centre C

When the vehicle body is subjected to a lateral force parallel to the running surface (gravity component, see figure 3a, or centrifugal force, see figure 3b) it tilts on its suspensions.

If the vehicle lateral play and the effect on its dampers have reached their limits in this condition, the  $XX'$  centreline of a lateral section takes up a  $XIX'1$  position.

In routine cases of vehicle lateral movements, the position of point C is independent of the lateral force involved. Point C is known as the roll centre of the

▼ **B**

vehicle and its distance  $h_c$  from the running surface is known as the height of the roll centre.

The value  $h_c$  can be measured or calculated. In the case of extreme vehicle/bogie positions for calculating the maximum construction gauge, this height  $h_c$  must be taken at one of the vehicle body/bogie bump stops concerned (centre or rotational stops); in the case where it can be neither measured nor calculated,  $h_c$  should be taken as equal to 0,5 m.

Fig.C3

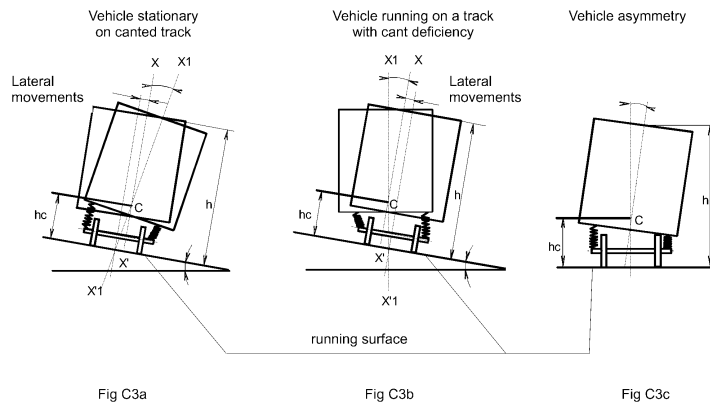
C.2.2.5. *Asymmetry*

The asymmetry of a vehicle is defined as the angle  $\eta_0$  that would be formed between the vertical and the centreline of the body of a stationary vehicle on level track in the absence of friction (see Figure 3c).

Asymmetry may result from constructional defects, unevenly adjusted suspension (scotching, side-bearers, pneumatic levelling valves, etc.) and from an off-centre load.

2.2.6. Coefficient of flexibility  $s$  (see Fig. C3)

Whenever a stationary vehicle is placed on a canted track whose running surface lies at an angle  $\delta$  to the horizontal, its body leans on its suspensions and forms an angle  $\eta$  with the perpendicular to the rail level. The vehicle flexibility coefficient  $s$  is defined by the ratio:

$$s = \frac{\eta}{\delta}$$

This ratio may be calculated or measured (see UIC Leaflet 505-5). It depends in particular on the load state of the vehicle.

**Powered units of constant weight:** Locomotives, etc: Unladen state in running order

**Vehicles with non-constant weight:** Multiple units, coaches, vans, coaches with driving cab, etc.

Unladen state in running order and exceptional load state (maximum load state)

**Vehicles with non-constant weight:** Wagons: Unladen state in running order and maximum load state

C.2.2.6. *Maximum construction gauge for rolling stock*

The maximum construction gauge is the maximum profile, obtained by applying the rules giving reductions in relation to the reference profile, which the various parts of the rolling stock must respect. These reductions depend on the geometric characteristics of the rolling stock in question, the position of the cross-section in relation to the bogie pivot or to the axles, the height of the point considered in

▼ **B**

relation to the running surface, constructional play, the maximum wear allowance and the elastic characteristics of the suspension.

In general, the effective construction gauge uses only partially the non-hatched areas within the maximum construction gauge for the installation of foot-steps, hand-rails, etc.

Fig. C4

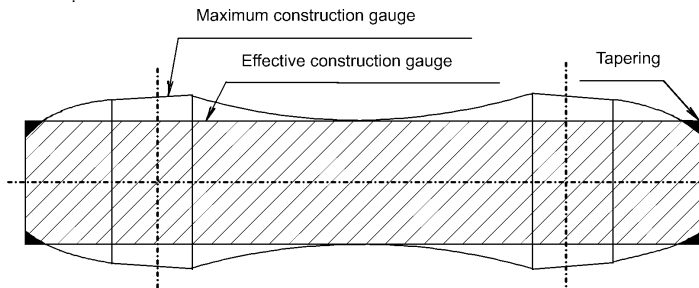

#### C.2.2.7. Kinematic gauge

This covers the furthest positions in relation to the centres of the normal co-ordinates likely to be taken by various parts of rolling stock, taking into account the most unfavourable positions of the axles on the track, the lateral play and quasi-static movements attributable to the rolling stock and to the track.

The kinematic gauge does not take account of certain random factors (oscillations, asymmetry, if  $\eta_0 \leq 1^\circ$ ): the suspended parts of the vehicles may therefore exceed the kinematic gauge in the course of oscillation. Such movements are taken into account by the Way and Works Department.

#### C.2.2.8. Quasi-static movements $z$

' $z$ ' is the part of lateral movements attributable to the rolling stock (when there is a 50 mm cant deficiency) and resulting from the technology and flexibility of the suspensions (flexibility coefficient  $s$ ), under the effect of centrifugal force not compensated for by cant or of excessive cant (see Figure 3a or 3b) and under the effect of asymmetry  $\eta_0$  (see Figure 3c). This value depends on the height  $h$  of the point in question.

#### C.2.2.9. $S$ projections (Fig.C5)

Part outside the reference profile when the vehicle is on a curve and/or on track with a gauge wider than 1,435 m.s

The half-width of the vehicle, plus the  $D$  movements, minus the half-width of the reference profile at the same level, is equivalent to the actual projection  $S$  in relation to the reference profile.

Also see Section 2.3 'Permitted projections'.

#### C.2.2.10. $E_i$ or $E_a$ reductions

To ensure that a vehicle when on the track does not exceed the 'vehicle limit position' in view of its  $D$  movements, the half-width dimensions must be subject to an  $E_i$  or  $E_a$  reduction, in relation to the reference profile, such that:

$$E_i \text{ or } E_a \geq D - S_0.$$

The following distinction is made:

- $E_i$  : reduction value for the reference profile half-width dimensions for the sections located between the end axles of vehicles not mounted on bogies or between the pivots of vehicles mounted on bogies

**▼ B**

- $E_a$  : reduction value for the reference profile half-width dimensions for the sections beyond the end axles of vehicles not mounted on bogies or the pivots of vehicles mounted on bogies.

C.2.2.11. *Lineside structure gauge*

Profile in relation to the axes of co-ordinates normal to the track, inside which no structure must penetrate despite elastic or non-elastic track movements.

C.2.3. **General comments on the method for obtaining the maximum rolling stock construction gauge**

The study of the maximum construction gauge takes into account both the lateral and vertical movements of the rolling stock, drawn up on the basis of the geometrical and suspension characteristics of the vehicle under various loading conditions.

In general, the maximum construction gauge of a vehicle is determined for the  $n_i$  or  $n_a$  values which correspond to the middle of the vehicle and the headstocks. It is of course necessary to check all the projecting points, as well as those which, in view of their location, are likely to be in close proximity to the vehicle construction maximum gauge within the section under consideration.

Transversally, taking into account the vehicle body movements obtained for a point located on an  $n_i$  or  $n_a$  section at height  $h$  in relation to the running surface, the half-widths of the maximum vehicle construction gauge shall be at the most equal to the corresponding half-widths of the reference profile, specific to each type of vehicle, decreased by the  $E_i$  or  $E_a$  reductions.

These reductions must satisfy the relationship  $E_i$  or  $E_a \geq D$  — So in which:

- $D$  represents the movements whose values are calculated by the formulae given in Para. 1.4.2.
- $So$  represents the maximum projections, the values of which are shown in Para. 2.3 'Permitted projections'.

▼ **B**C.2.3.1. *Relative positions of the various gauges*

Fig.C5 shows the position of the various gauges in relation to each other, as well as the main elements involved in determining the rolling stock maximum construction gauge.

Fig. C5

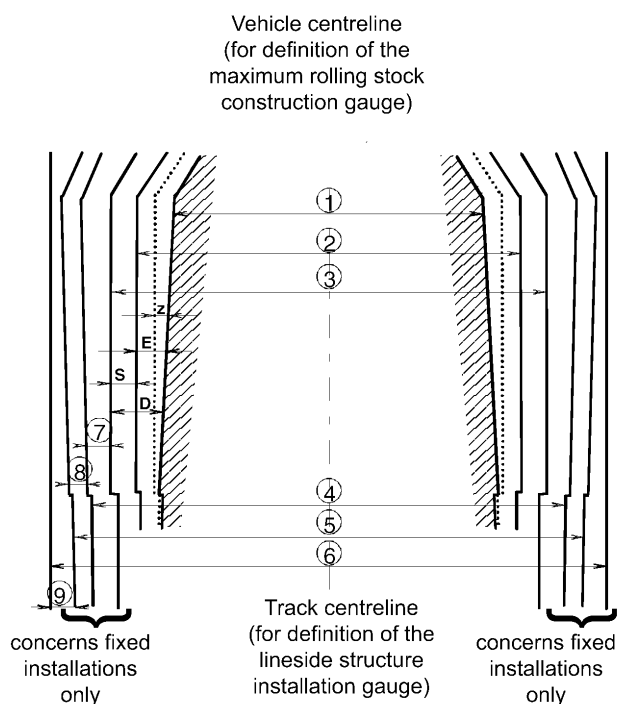
**Gauges****Figure C5**

- ① Rolling stock maximum construction gauge
- ② Kinematic gauge reference profile
- ③ Limit position of rolling stock considered in the reduction formulae
- ④ Rolling stock kinematic gauge
- ⑤ Lineside structure limit gauge
- ⑥ Lineside structure installation gauge

$z$  = quasi-static movement taken into account in the reduction formulae:

- for a cant excess or deficiency of 0.05 m,
- for that part of the asymmetry exceeding  $1^\circ$
- for cant excess or deficiency between 0.05 m and 0.2 m maximum which is not taken into account by the Way and Works Department if  $s > 0.4$  and/or  $h_c < 0.5$  m.

$E$  = Reduction ( $E_1$  or  $E_2$ )

$S$  = Lateral projection (for the rolling stock  $S_0$  = maximum projection)

$D$  = Lateral movement

- ⑦ Quasi-static movement due to cant excess or deficiency exceeding 0.05 m (for  $s = 0.4$ ,  $h_c = 0.5$  m)
- ⑧ Value added by the Way and Works Department in order to take into account track defects in service, oscillations and asymmetries of  $\leq 1^\circ$  and resulting movements.
- ⑨ Margin specific to each Railway in order to take into account special situations (transport of exceptional loads, margins for increasing the speed, high prevailing cross-winds).



**▼B****C.2.4. Rules for the reference profile for determining the maximum rolling stock construction gauge**

In order to determine the maximum construction gauge of a vehicle, the Rules for the reference profiles must take account of:

- vertical movements,
- transverse movements.

Construction tolerances are partly taken into account in the asymmetry calculation.

The nominal width value of a vehicle is obtained from the dimensions of the maximum constructional profile.

Tolerance values must not be used systematically to increase vehicle dimensions.

**C.2.4.1. Vertical movements**

For the vehicle or for a given part, these movements make it possible to determine a minimum height and a maximum height above the running surface; this is particularly the case for:

- parts located towards the lower section of the gauge (low parts);
- the step at 1 170 mm from the running surface on the reference profile;
- parts located at the upper part of the vehicles.

It should be noted that for all parts located at a height greater than 400 mm above the running surface, the vertical component of the quasi-static movements is not taken into account.

**C.2.4.1.1. Determination of minimum heights above the running surface**

The minimum heights above the running surface for parts located towards the lower part of the gauge (1 170 mm and below) are determined with account being taken of the vertical movements described in the following paragraphs.

When studying the sag of the vehicle bodies (also see Appendix 2) the division shown in the diagram below shall be considered.

*Fig. C6*

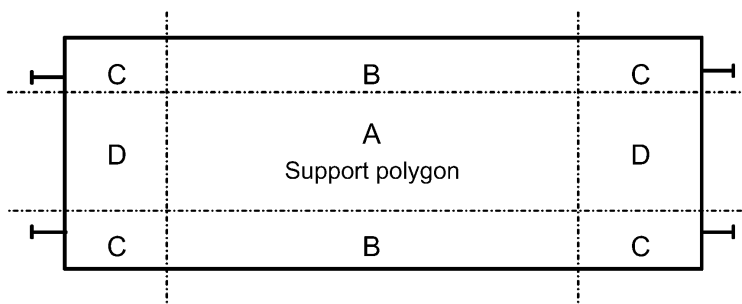

Sags independent of the load state and of the suspension state

These deflections shall be considered for all vehicle body zones A, B, C and D, and concern the following parts:

- Wheels : maximum wear for all types of vehicles
- Various parts : maximum wear — Examples: side-bearers, brake rigging, etc, for all vehicles and for each special assembly
- Axle boxes : wear ignored
- Bogie frame : manufacturing tolerances giving rise to deflection in relation to the nominal dimensions: ignored
- Body structures : manufacturing tolerances giving rise to deflection in relation to the nominal dimensions: ignored for all vehicles including all conventional and special wagons.

**▼B**

Deflection dependent on the load state of the vehicles and on the state of their suspension

1 — Structural distortions: sags for all the vehicle body zones A, B, C, and D.

— Axles	Deflection ignored	
— Bogie frame	Deflection ignored	
— Body	Transverse deflection	ignored
	Twist	ignored
	Longitudinal deflection	ignored for all vehicles, except wagons for which the longitudinal sag must be taken into account under the effect of a maximum load increased by 30 % to take dynamic stresses into consideration.

2 — Deflection of the suspensions

Types of springs:

The primary and secondary suspensions are formed of various types of springs for which the deflections must be taken into account:

- Steel spring Deflection under static load, Additional deflection under dynamic stress, Deflection due to flexibility tolerances.
- Rubber spring Same deflections as for steel springs
- Pneumatic spring Total deflection with cushions deflated (including back-up suspension when it exists)
- Suspension deflection conditions
  - Equal and simultaneous deflections on the suspensions (zones A, B, C and D are concerned).
  - ‘Conventional’ wagons: total deflection (bottoming).
  - Special wagons: deflection under the effect of a 30 % overload on the sprung weight (in order to make maximum use of the gauge, especially in the case of combined transport or of bulky loads) or total deflection (bottoming).
  - Other deflections see Appendix 3.

C.2.4.1.2. Passing over vertical transition curves (including marshalling yard humps) and over braking, shunting or stopping devices.

a) Vehicles with a reference profile (part below 130 mm) in accordance with paragraph C.3.2.3

Normal values for the  $e_i$  or  $e_a$  vertical reductions to be taken into account for empty coaches, empty or loaded vans and wagons.

These vehicles, when they can be gravity shunted, must be capable of passing over activated rail brakes and other shunting or stopping devices located on non-vertically curved track and reaching the 115 and 125 mm dimensions above the running surface, up to 3 m from the end of convex transition curves of radius  $R_v \geq 250$  m (dimension d).

They must also be able to pass over such devices located inside or near concave transitions curves of radius  $R_v \geq 300$  m.

In applying these conditions, the lower dimensions of these vehicles, taking into account vertical movements, assessed as stated in paragraph § 1.4.1, must in relation to the running surface be at least equal to 115 or 125 mm increased by the following  $e_i$  or  $e_a$  quantities:

▼B

Fig.C7

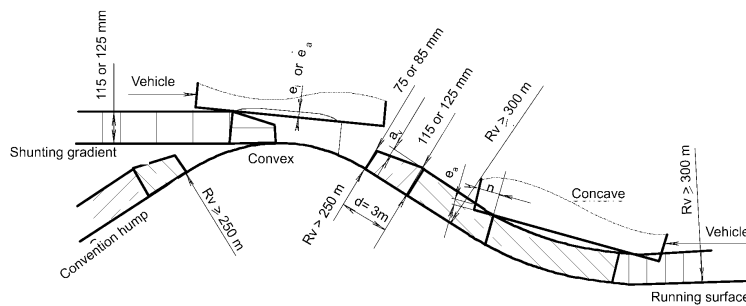

$e_i$  or  $e_a$  : vertical reduction at the lower part of the rolling stock equipment in relation to the 115 or 125 mm dimensions.

$e_v$  : lowering of the rail brakes in relation to the 115 or 125 mm dimensions.

For sections between the end axles or bogie pivots (normal values expressed in metres) The purpose of the numerical index applied to the  $e_i$  and  $E'i$  values is to distinguish the normal values from the reduced values:

$$e_{i1} = \frac{n}{a} \cdot \frac{(a-n-3)^2}{500} \text{ when } a \leq 17,80 \text{ m and } n < \frac{a-3}{n}$$

$$e_{i1} = \frac{(a-3)^3}{3375a} \text{ wh when } a \leq 17,80 \text{ m and } n \geq \frac{a-3}{3} \text{ (1)}$$

$$e_{i1} = \left[ \frac{27}{4} \cdot \frac{n}{a-3} \right] \left[ 1 - \frac{n}{a-3} \right]^2 \left[ \frac{a^2}{3375} - 0,04 \right] \text{ when } a > 17,80 \text{ m and } n < \frac{a-3}{3}$$

$$e_{i1} = \frac{a^2}{3375} - 0,04 \text{ when } a > 17,80 \text{ m and } n \geq \frac{a-3}{3} \text{ (1)}$$

NOTES

(1) This formula for  $n \geq \frac{a-3}{3}$  gives reductions greater than or equal to those resulting from the formula for  $n < \frac{a-3}{3}$

When empty coaches and empty or loaded wagons and vans can be gravity shunted, they must also be able to pass over convex transition curves of radius  $\geq 250$  m, without any part other than the wheel flange descending below the running surface.

This condition, which concerns the central part of the vehicles, is in addition to those resulting from the  $e_i$  formulae for long vehicles.

Fig. C8

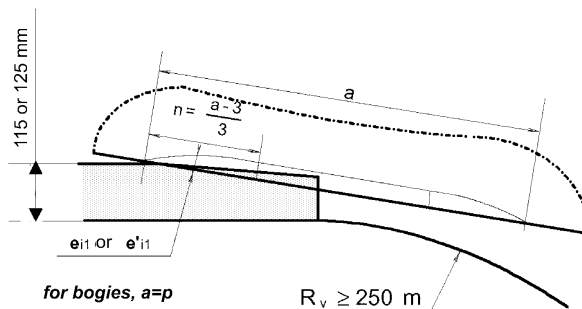

## ▼ B

For sections located beyond the end axles or bogie pivots (values in metres)

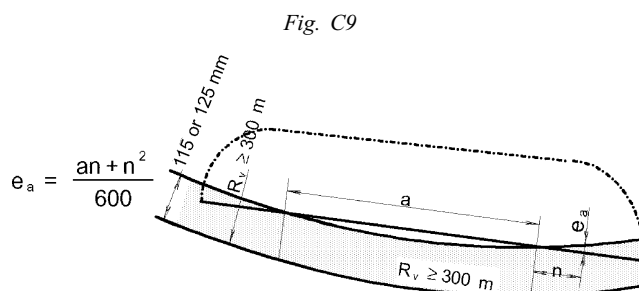

Reduced values for the  $e_i$  increase (sections between the end axles or bogie pivots) to be considered for certain vehicles for passing over gradient transition curves including shunting humps.

These reduced values are only tolerated for certain types of wagon, insofar as they require a larger space than that determined using the normal values. These are, for example, the recess wagons used in rail/road combined traffic, and other identical or similar designs.

Use of these reduced values may require special precautions to be taken in certain marshalling yards with hump retarders at the base of a shunting gradient.

For these vehicles, the value of dimension  $d$  becomes 5 m.

Fig. C10

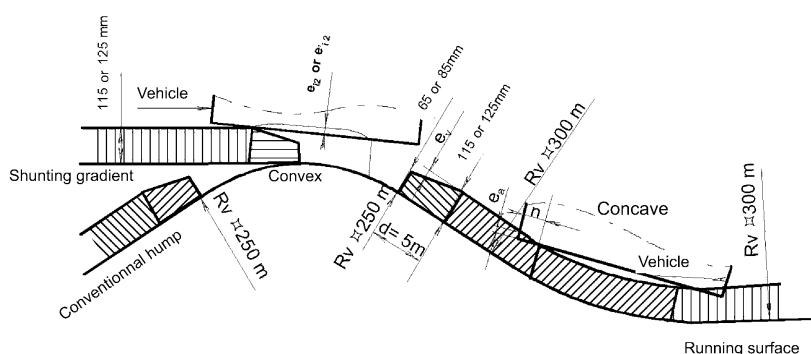

(reduced values expressed in metres)

$$e_{i2} = \frac{n}{a} \cdot \frac{(a - n - 5)^2}{500} \text{ when } a \leq 15,80 \text{ m and } n < \frac{a - 5}{3}$$

$$e_{i2} = \frac{(a - 5)^3}{3375a} \text{ when } a \leq 15,80 \text{ m and } n \geq \frac{a - 5}{3}$$

$$e_{i2} \left[ \frac{27}{4} \cdot \frac{n}{a - 5} \right] \left[ 1 - \frac{n}{a - 5} \right]^2 \left[ \frac{a^2}{3375} - 0,05 \right] \text{ when } a > 15,80 \text{ m and } n < \frac{a - 5}{3}$$

$$e_{i2} = \frac{a^2}{3375} - 0,05 \text{ when } a > 15,80 \text{ m and } n \geq \frac{a - 5}{3} \text{ (1)}$$

## NOTES

- (1) This formula for  $n \geq \frac{a-5}{3}$  gives reductions greater than or equal to those obtained using the formula for  $n < \frac{a-5}{3}$

When they can be gravity shunted, the wagons must also be able to pass over convex transition curves with a radius greater than or equal to 250 m, without any part other than the wheel flange descending below the running surface.

▼ B

This condition, which concerns the central part of the wagons, is in addition to those resulting from the  $e_i$  formulae for long wagons.

Fig. C11

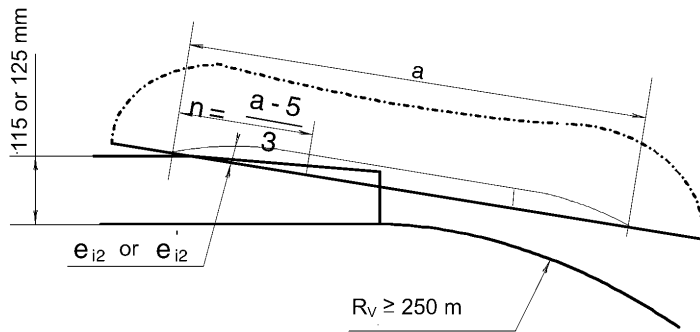

For bogies  $a = p$ .

Table C1 showing the values of  $E_i$  and  $E'_i$  expressed in mm with a and n expressed in m.

a \ n	≥ 6	5,5	5	4,5	4	3,5	3	2,5	2	1,5	1	0,5	0																					
20	79	69	78	69	78	68	73	66	69	63	57	54	49	46	39	37	28	27	15	14	0	0												
19,5	73	63	73	63	72	63	71	62	68	61	65	59	60	55	54	50	46	43	37	35	26	25	14	14	0	0								
19	67	57	67	57	67	57	66	57	64	56	60	54	56	51	50	46	43	40	35	33	25	24	13	13	0	0								
18,5	61	51	61	51	61	51	61	51	59	51	56	49	52	47	47	43	41	37	33	30	23	22	13	12	0	0								
18	56	46	56	46	56	46	56	46	54	46	52	45	48	42	44	39	38	34	31	28	22	20	12	11	0	0								
17,5	52	41	52	41	52	41	51	41	50	41	48	40	45	38	41	35	36	31	29	26	21	19	11	10	0	0								
17	48	36	48	36	48	36	48	36	47	36	45	35	43	34	39	31	34	28	28	23	20	17	11	9	0	0								
16,5	44	31	44	31	44	31	44	31	44	31	42	30	40	30	37	28	32	25	26	20	19	15	10	8	0	0								
16	41	26	41	26	41	26	41	26	41	26	40	26	38	25	34	24	30	21	25	18	18	13	10	7	0	0								
15,5	37	22	37	22	37	22	37	22	37	22	37	22	35	22	32	21	28	19	23	16	17	12	9	6	0	0								
15	34	20	34	20	34	20	34	20	34	20	34	20	32	20	30	19	27	17	22	14	16	11	9	6	0	0								
14,5	31	18	31	18	31	18	31	18	31	18	31	18	30	17	28	17	25	16	21	13	15	10	8	6	0	0								
14	28	15	28	15	28	15	28	15	28	15	27	15	26	15	26	15	23	14	19	12	14	9	8	5	0	0								
13,5	25	13	25	13	25	13	25	13	25	13	25	13	24	13	24	13	21	13	18	11	13	8	7	5	0	0								
13	23	12	23	12	23	12	23	12	23	12	23	12	22	12	20	11	17	10	12	8	12	8	7	4	0	0								
12,5	20	10	20	10	20	10	20	10	20	10	20	10	20	10	18	10	15	9	12	7	12	7	7	4	0	0								
12	18	8	18	8	18	8	18	8	18	8	18	8	18	8	16	8	14	8	11	6	11	6	6	4	0	0								
11,5		16	7	16	7	16	7	16	7	16	7	16	7	16	7	15	7	13	7	10	5	10	5	6	3	0	0							
11		14	6	14	6	14	6	14	6	14	6	14	6	14	6	14	6	13	6	12	6	9	5	5	3	0	0							
10,5			12	5	12	5	12	5	12	5	12	5	12	5	12	5	12	5	10	5	8	4	5	2	0	0	0							
10			10	4	10	4	10	4	10	4	10	4	10	4	10	4	10	4	9	4	7	3	4	2	0	0	0							
9,5				9	3	9	3	9	3	9	3	9	3	9	3	9	3	9	3	8	3	6	3	4	2	0	0	0						
9					7	2	7	2	7	2	7	2	7	2	7	2	7	2	7	2	6	2	3	1	0	0	0	0						
8,5						6	1	6	1	6	1	6	1	6	1	6	1	6	1	6	1	5	1	3	1	0	0	0						
8							5	1	5	1	5	1	5	1	5	1	5	1	5	1	5	1	4	1	3	1	0	0	0					
7,5								4	1	4	1	4	1	4	1	4	1	4	1	4	1	4	1	3	1	2	1	0	0	0				
7									3	0	3	0	3	0	3	0	3	0	3	0	3	0	3	0	2	0	0	0	0	0				
6,5										2	0	2	0	2	0	2	0	2	0	2	0	2	0	2	0	1	0	0	0	0	0			
6																					1	0	1	0	1	0	0	0	0	0	0			
5,5																						1	0	1	0	1	0	0	0	0	0	0		
5																							0	0	0	0	0	0	0	0	0	0	0	
4,5																								0	0	0	0	0	0	0	0	0	0	0



**▼B**

- b) Vehicles not allowed on shunting humps by reason of their length

Empty coaches, wagons suitable for international traffic and empty or loaded vans that are not allowed over marshalling yard humps on account of their length, must nonetheless respect the profile in paragraph C.3.2.3 when placed on a non-vertically curved track, so as to allow for the use of shunting or stopping devices.

- c) All vehicles

All vehicles must be able to pass over convex or concave transition curves of radius  $R_v \geq 500$  m, without any part other than the wheel flange descending below the running surface.

This may concern mainline vehicles whose:

- wheelbase is greater than 17,8 m,
- overhang is greater than 3,4 m.

- d) Special cases

Account must be taken of the following particular cases:

- Vertical transition curves for vehicles fitted with the automatic coupler.
- Angle of inclination for vehicles used on ferries.

**C.2.4.1.3. Determination of maximum heights above the running surface**

The value of vertical movements to be taken into consideration, as regards the upper parts of rolling stock where  $h \geq 3\,250$  mm, is determined with account being taken of the upward dynamic movements for empty rolling stock in running order without wear.

In this part, the vehicles come close to the reference profile under the influence of:

- 1) upward oscillations,
- 2) the vertical component of the quasi-static inclination,
- 3) transverse movements.

Consequently, the vertical dimensions of the reference profile must be reduced by the values generated by these movements  $\xi$ , if they can be calculated, or otherwise by a fixed value of 15 mm per suspension stage.

Nevertheless, it must be noted that when the vehicle is subject to quasi-static inclination, the side opposite the inclination rises but at the same time moves away from the reference profile in such a way that no interference is to be feared. Conversely, on the side of the inclination, the vehicle lowers, thus compensating part of the upward movements.

As an approximation, for cant excess or deficiency of 50 mm, this vertical reduction  $\Delta V(h)$  of the reference profile for nominal heights greater than  $h = 3,25$  m is expressed as:

$$\Delta V(h) = \xi - \left\{ \frac{\left[ \frac{1}{2} \text{LCR}(h) - E_i \text{ or } a \right] s}{30} \right\}$$

where:

- $\frac{1}{2} \text{LCR}(h)$  represents the half-width of the reference profile,
- $E_i$  or  $E_a$  the transverse reductions,
- $s$  the vehicle's coefficient of flexibility,
- $\xi$  the vehicle resilience (fixed or calculated term).

Example: for a vehicle with a reduction  $E_i$  or  $E_a$  of 217 mm based on  $h = 3,25$  m, we obtain:

## ▼B

Reductions for cut-away sides on the upper part of the reference profile.

Fig. C12

Vehicles with 2 suspension stages  $s = 0.3; \xi = 30 \text{ mm}$

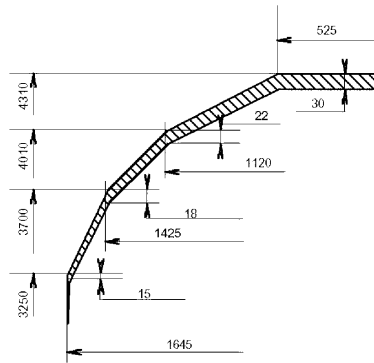

Vehicles with 1 suspension stage  $s = 0.1; \xi = 15 \text{ mm}$

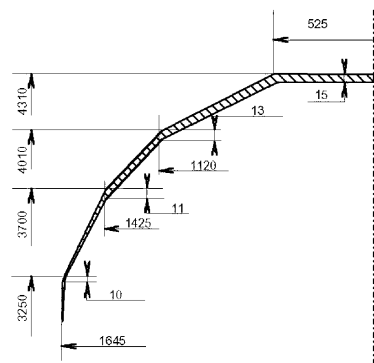

#### C.2.4.2. Lateral movements (D)

These movements are the sum of the following movements:

- geometric movements resulting from the vehicle running through curves and straight track (projections, lateral play, etc.), where the vehicle centreline is considered to be perpendicular to the running surface;
- quasi-static movements resulting from the inclination of the suspended parts under the influence of gravity (canted track) and/or centrifugal acceleration (curved track).
- lateral sag of the vehicle body is generally disregarded except for those special types of wagon or heavily-laden wagons for which these values are particularly high.

##### C.2.4.2.1. Vehicle running position on the track and displacement factor (A)

The various vehicle running positions on the track depend on the transverse play of the various parts connecting the vehicle body to the track and on the configuration of the running gear (independent axles, powered bogies, trailer bogies, etc).

It is therefore necessary to consider the various positions which the vehicle may take up on the track so as to take into account any displacement factor  $A$  to be applied to certain terms in the fundamental formulae used for calculating the  $E_i$  internal and  $E_a$  external reductions.

The displacement factor and the vehicle running position on the track are given in the table below. For the cases of axle configuration not represented in the table, the running position conditions to be taken into account must be the least favourable.

▼B

For articulated vehicles, it is recommended to take the running position for conventional 2-bogie vehicles.

Table 2 Displacement factor and vehicle position on the track

Calculation of internal reductions $E_i$							
Vehicle type	Running position on the track	Terms to which A factor applies	$\frac{1.465 - d}{2}$	W		$\frac{p^2}{4}$ (on curve)	
				on straight track	depending on curve radius		
				$W_{\infty}$	$W'_{i(R)}$		
On straight track			Displacement factor A				
1	2-axle vehicles or bogies taken individually and associated parts		1				
2	2-bogie vehicles except those below		1	1			
3	Vehicle with on designated "motor" bogie leading and one trailer bogie leading or considered as such		1	$\frac{W_{\infty}}{a - n_{ii}}$	$\frac{W'_{\infty}}{n_{ii} / a}$		
On curve			Displacement factor A				
4	2-axle vehicles or bogies taken individually and associated parts		The running positions and displacement factors for curves are the same as for straight track				
5	Vehicles with 2 motor bogies or designated as "motored"		1		1	1	
6	Vehicles with 1 bogie designated as "motored" (M) and 1 trailer bogie or bogie designated as unpowered (P)		$\frac{a - n_{ii}}{a}$		$\frac{W_{i(R)}}{a - n_{ii}}$	$\frac{W'_{i(R)}}{a - n_{ii}}$	$\frac{p^2}{4}$
7	Vehicles with 2 trailer bogies or considered as such (1) special case for wagons		0 0(1)		1 1(1)	1 1(1)	



▼B

Calculation of the external reductions $E_a$									
Running position on the track	Terms to which A factor applies	$\frac{1,465-d}{2}$	q	Displacement factor A			$\frac{p^2}{4}$		
				on straight track	depending on curve radius		(on curve)		
				$W_{cs}$	$W_{i(R)}$	$W_{a(R)}$			
<b>On straight track</b>		<b>Displacement factor A</b>							
		$\frac{2n+a}{a}$	$\frac{2n+a}{a}$	/	/	/	/	/	/
		$\frac{2n+a}{a}$	$\frac{2n+a}{a}$	$\frac{2n+a}{a}$	/	/	/	/	/
		$\frac{2n+a}{a}$	$\frac{2n+a}{a}$	$W_{cs}$ leading motor bogie $\frac{n+a}{a}$	$W'_{cs}$ $\frac{n}{a}$	/	/	/	/
				$\frac{n}{a}$ leading trailer bogie	$\frac{n+a}{a}$	/	/	/	/
<b>On curve</b>		<b>Displacement factor A</b>							
		The running positions and displacement factors for curves are the same as for straight track							
		$\frac{2n+a}{a}$	$\frac{2n+a}{a}$	/	$\frac{n}{a}$	$\frac{n+a}{a}$	1		
		$\frac{n+a}{a}$	$\frac{2n+a}{a}$	/	$W_{i(R)}$	$W'_{i(R)}$	$W_{a(R)}$	$W'_{a(R)}$	$\frac{p^2}{4}$
					$\frac{n}{a}$	$\frac{n+a}{a}$	$\frac{n+a}{a}$	$\frac{n}{a}$	$\frac{p^2}{4}$
		$\frac{2n+a}{a}$	$\frac{2n+a}{a}$	/	$\frac{n}{a}$	$\frac{n+a}{a}$	$\frac{n}{a}$	$\frac{n+a}{a}$	
		$\frac{n+a}{a}$	$\frac{2n+a}{a}$	/	$\frac{n}{a}$	$\frac{n+a}{a}$	1		
		$\frac{n+a}{a}^{(1)}$	$\frac{2n+a}{a}^{(1)}$	$\frac{2n+a}{a}^{(1)}$	/	/	1 <sub>(1)</sub>		

▼B

Fig. C13

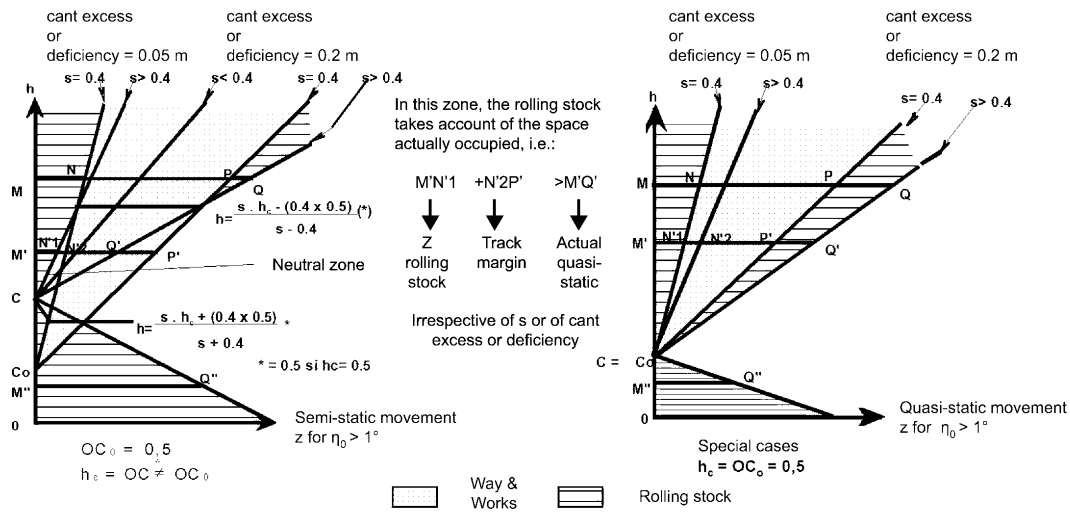

C.2.4.2.2. Special cases of multiple units and coaches fitted with a reversing cab (driving trailer)

For this rolling stock, the bogies are classified according to their adhesion coefficient  $\mu$  on starting.

- If  $\mu \geq 0,2$                       the bogie is designated                      ‘motor’
- If  $0 < \mu < 0,2$                       the bogie is considered                      ‘trailer’
- If  $\mu = 0$                       the bogie is                      ‘trailer’.

C.2.4.2.3. Quasi-static movement (z)

These movements are taken into account when calculating  $E_i$  or  $E_a$ , depending on the flexibility coefficient s, the height h above the running surface of the point under consideration and the height of the roll centre  $h_c$ .

The Way and Works Department shall define the lineside clearance gauge for  $h > 0,5$  m, when the effective cant excess or deficiency of the track is greater than 0,05 m calculating in conventional manner the extra quasi-static inclination for rolling stock with a coefficient of flexibility of 0,4 and a roll centre height of 0,5 m.

The Rolling Stock Department shall determine  $E_i$  and  $E_a$  taking into account:

- a cant excess or deficiency of 0,05 m;
- where appropriate a cant excess or deficiency of 0,2 m, when the respective values of s and  $h_c$  lead to the gauge defined by the Way and Works Department being exceeded (see figure below and paragraph 1.5.1.3).
- of the influence, beyond  $1^\circ$ , of the asymmetry resulting from design and adjustment (1) tolerances (side-bearers play) and from any unevenness in the distribution of the normal load. The influence of asymmetry less than  $1^\circ$  is taken into account in the lineside clearance gauge, as are the lateral oscillations created randomly by causes inherent both to the rolling stock and track (for resonance phenomena in particular).

▼ **B**

Straight line	Equation	From the equations opposite, infer the lengths of the segments below, the values of which also appear in the 'special cases' in Para. 8.1.3:
CoN	$z = 0,4 \cdot 0,05 \left  \frac{h - 0,5}{1,5} \right $	Cant excess or deficiency = 0,05 m
	$z = s \cdot 0,05 \left  \frac{h - h_c}{1,5} \right $	$\overline{MN}'_1 = s \cdot 0,05 \frac{h - h_c}{1,5} = \frac{s}{30}  h - h_c $
	$z = 0,4 \cdot 0,2 \left  \frac{h - 0,5}{1,5} \right $	
CN'1	$z = s \cdot 0,2 \left  \frac{h - h_c}{1,5} \right  = \frac{4s}{30}  h - h_c $	Cant excess or deficiency = 0,2 m
		$\overline{MQ} \text{ or } \overline{M''Q''} = \left( \frac{S}{30} + \frac{S}{10} \right)  h - h_c $
		$= \frac{4s}{30}  h - h_c $
CoP		$\overline{NP} = 0,4(0,2 - 0,05) \frac{h - 0,5}{1,5}$
		$= 0,04(h - 0,5)$
CQ		
CQ'}		

(in the above formulae, dimensions are given in metres)

### C.2.5. Determination of reductions by calculation

Reductions  $E_i$  and  $E_a$  are determined on the basis of the following fundamental relation:

Reduction  $E_i$  or  $E_a$  = Movement  $D_i$  or  $D_a$  — Projection  $S_0$

Internal reductions

$$E_i = \frac{an_i - n_i^2 + \frac{p^2}{4}(A)}{2R} + \frac{1,465 - d}{2}(A) + q + w(A) + z + x_i - S_0$$

and external reductions

$$E_a = \frac{an_a + n_a^2 - \frac{p^2}{4}(A)}{2R} + \frac{1,465 - d}{2}(A) + q(A) + w(A) + z + x_a - S_0$$

In these formulae:

—  $A$ , displacement factor, describes the position of the axles on the track. Values for  $A$  are given in paragraph (see section C.2.4.2.1).

—  $D_i$  or  $D_a$  is the sum of the movements defined in the following paragraph.

—  $S_0$  is the maximum projection.

$x_i$  and  $x_a$  are special terms for the calculation for vehicles with very large wheelbase.

#### C.2.5.1. Terms taken into account in calculating movements ( $D$ )

In view of the particular features of each type of vehicle, additional terms are necessary and some parameters may alter the following terms:

**▼ B**

C.2.5.1.1. Terms concerning the running position of the vehicle on a curve (geometric overthrow)

$\frac{1}{2R} \left( a n_i - n_i^2 + \frac{p^2}{4} \right)$  = Geometric overthrow of a given section towards the inside of a curve of radius R (problem of vehicle body sections located on inside of bogie pivots or of axles).

$\frac{1}{2R} \left( a n_a + n_a^2 - \frac{p^2}{4} \right)$  = Geometric overthrow of a given section towards the outside of a curve of radius R (problem of vehicle body sections located on outside of bogie pivots or of axles)

*Note:* for special vehicles with particular bogie configurations, these formulae may need to be adapted.

C.2.5.1.2. Group of terms concerning lateral play

The value of all these plays is measured at right angles to the axles or pivots, with all parts at wear limit.

The vehicle running positions on the track, as shown in paragraph 7.2.2, enable the play to be taken into account in the formulae and the value of the displacement coefficient applicable to be determined, in order to calculate their effect on the section considered.

$\frac{1,465 - d}{2}$  = play of the axle in the track

q = play between axles and underframe and/or between axle and vehicle body. In other words, the lateral movement between axle-boxes and journals, plus that between the underframe and axle-boxes from the central position and on each side.

w = play of bogie pivots or bolsters. This is the possible lateral movement of the bogie pivots or bolsters, from the central position and on each side, or, for vehicles without a pivot, the possible lateral movement of the vehicle body in relation to the bogie frame, from the central position and depending on the curve radius and the direction of movement.

If the value of w varies with the curve radius:

—  $w_i(R)$  means that w is considered for radius R and the inside of the curve;

—  $w_a(R)$  means that w is considered for radius R and the outside of the curve;

—  $w_\infty$  means that w is considered for straight track.

According to the specific features of each type of vehicle, this term may be rotated:  $w'$ ,  $w_i$ ,  $w'_i$ , etc. It can also be equal to the sum of some of these notations:  $w_i + w_a$ , etc, each of these terms being potentially influenced by the corresponding displacement factor.

C.2.5.1.3. Quasi-static movements (term concerning vehicle['s] inclination [leaning] on its suspension and its asymmetry when this is greater than 1°)

Paragraph C.2.4.2.3. 'Quasi-static movements' gives a chart showing the different parts making up the term z

z = deviation from the track central position. This deviation is equal to the sum of 2 terms:

—  $\frac{s}{30} |h - h_c|$ : term concerning the inclination due to the suspension (lateral movement due to the flexibility of the suspension, under the influence of cant excess or deficiency of 0,05 m);

$\tan[\eta_0 - 1^\circ] |h - h_c|$ : term concerning the asymmetry, (lateral movement due to that part of the asymmetry exceeding 1)

This sum may be increased by:

$\left[ \frac{s}{10} |h - h_c| - 0,04 [h - 0,5]_{>0} \right]_{>0}$ : term integrating cant excess or deficiency of

0,2 m and applicable under the conditions defined in paragraph 1.4.2.3.

**▼ B**

For sprung parts located at height  $h$ , the above terms give, in the formulae, a value of:

$$z = \left[ \frac{s}{30} + \tan[\eta_0 - 1^\circ]_{>0} \right] |h - h_c| + \left[ \frac{s}{10} |h - h_c| - 0,04[h - 0,5]_{>0} \right]_{>0}$$

a) Special cases

$$\text{— when } \left\{ \begin{array}{l} h > h_c \text{ and } 0,5\text{m} \\ s \leq 0,4 \\ \eta_0 \leq 1^\circ \end{array} \right\} \quad z = \frac{s}{30} (h - h_c)$$

$$\text{— when } \left\{ \begin{array}{l} h < 0,5\text{m} \\ \eta_0 \leq 1^\circ \\ \text{and for any value of } h_c \text{ and } s \end{array} \right\} \quad z = \frac{4s}{30} |h_c - h|$$

$$\text{— when } h = h_c \quad z = 0$$

For unsprung parts  $z = 0$ .

b) Influence of side-bearers play for wagons fitted with bogies

— For wagons fitted with bogies whose side-bearers play is less than or equal to 5 mm, the  $1^\circ$  angle of asymmetry is considered to cover this play and the formula  $\eta_0 = 1^\circ$  is conventionally used.

The term 'z' taking into account side-bearers play less than or equal to 5 mm is given as:

$$z = \left[ \frac{s}{30} \right] |h - h_c| + \left[ \frac{s}{10} |h - h_c| - 0,04[h - 0,5]_{>0} \right]_{>0}$$

and account must be taken of the special cases described above.

— For wagons fitted with bogies whose side-bearers play is greater than 5 mm, account should be taken of the additional inclination  $\alpha$  of the vehicle body, expressed as follows:

$$\alpha = \arctan \frac{J - 0,005}{b_G}$$

This additional inclination  $\alpha$  leads to compression of the suspension which, when multiplied by the coefficient of flexibility  $s$ , is given as a rotation of the vehicle body:  $as$  (where  $s$  is the coefficient of flexibility).

The total additional inclination may be expressed as:

$$\alpha (1 + s)$$

The term  $z$  taking account of side-bearers play greater than 5 mm becomes:

$$z = \left\{ \frac{s}{30} + \tan \left[ \eta'_0 + \left( \arctan \frac{J - 0,005}{b_G} \right) (1 + s) - 1^\circ \right]_{>0} \right\} |h - h_c| + \left[ \frac{s}{10} |h - h_c| - 0,04[h - 0,5]_{>0} \right]_{>0}$$

*Note:*  $||_{>0}$  means that the expression between the square brackets should be taken as its own value if that value is positive or as 0 if that value is negative or null.

$\eta'_0$  = asymmetry in the case of 5 mm side-bearers play.

c) Special terms  $x_i$  and  $x_a$

Terms representing the correction to be made to certain formulae used to calculate the reductions  $E_i$  and  $E_a$  for the parts distant from the pivots of vehicles with a very large wheelbase and/or very large overhang in order to limit space requirement in curves of radius between 250 m and 150 m:

It will be noted that:

—  $x_i$  only enters the formulae if  $\frac{a^2 + p^2}{4} > 100$ , i.e. an approximate value for a of 20 m;

—  $x_a$  only applies if  $an_a + n_a^2 - \frac{p^2}{4} > 120$  (exceptional case)

**▼ B**

Special condition for  $x_a$ :

The term  $x_a$  is not used in the calculation of reductions applicable to vehicles whose overhang respects the conditions laid down for the automatic coupler.

### C.3. GAUGE G1

In 1991 the decision was taken that the regulations for static gauge should no longer be used for the construction of wagons.

The static gauge regulations therefore remain applicable only to the gauges specially defined for loads, which was the case for example with gauges GA, GB, GB1, GB2 and GC.

Static gauge regulations mentioned below include:

1. a reference profile (upper sections),
2. reduction formulae linked with this profile.

#### C.3.1. Reference profile for static gauge G1

Fig. C14

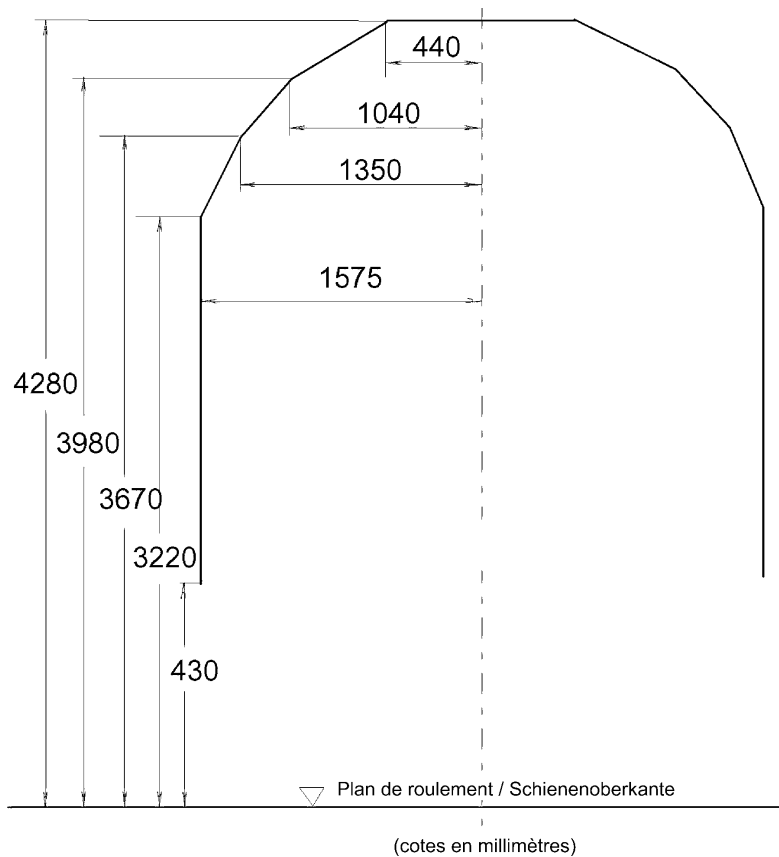

#### C.3.1.1. Reduction formulae

**Sections between the end axles or the bogie pivots**

$$E_i = \left[ \frac{\Delta_i}{500} + \frac{1,465 - d}{2} + q + w + x_{i>0} - 0,075 \right] > 0$$

with:  $\Delta_i = 7,5$  if  $\left( an - n^2 + \frac{p^2}{4} \leq 7,5 \right)$

$$\Delta_i = \left( an - n^2 + \frac{p^2}{4} \right) \text{ if this quantity } > 7,5$$



## ▼B

In the case of wagons intended to run in transit on the Finnish network, the elements of the lower parts must respect the gauge in accordance with the specific standards.

Wagons which must not pass over shunting humps with a curvature radius of 250 m or track brakes and other shunting and stopping devices:

- shall not be allowed to carry the RIV sign, unless otherwise expressly specified in the standards
- are required to bear the inscription to that effect.

C.3.2.2. *Part below 130 mm on vehicles which must not pass over shunting humps or negotiate rail brakes and other activated shunting and stopping devices*

Certain gauge restrictions must be observed at right angles to the axles when vehicles are placed on an under-floor wheel lathe for wheel reprofiling.

Fig. C16

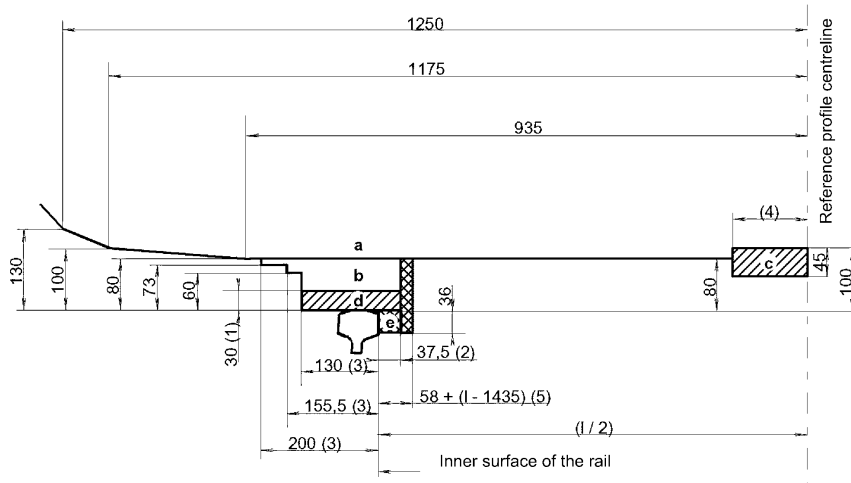

(Dimensions in millimetres)

- a) zone for equipment away from wheels
  - b) zone for equipment in immediate proximity of wheels
  - c) zone for contact ramp brushes
  - d) zone for wheels and other parts coming into contact with the rails
  - e) zone occupied exclusively by the wheels
- 1) Limit for parts located outside the axle ends (guard irons, sanders, etc.) not to be exceeded for running over detonators. This limit may however be disregarded for parts located between the wheels, provided these parts remain within the wheel track.
  - 2) Maximum theoretical width of the flange profile in the case of check-rails.
  - 3) Effective limit position of the outside surface of the wheel and of the parts associated with this wheel.
  - 4) When the vehicle is in any position whatsoever on a curve of radius  $R = 250$  m (minimum radius for contact ramp installation) and a track width of 1 465 mm, no part of the vehicle likely to descend to less than 100 mm from the running surface, except for the contact brush, should be less than 125 mm from the track centre.
- For parts located inside the bogies, this dimension is 150 mm.
- 5) Effective limit position of the internal surface of the wheel when the axle is against the opposite rail. This dimension varies with gauge widening.



## ▼B

C.3.2.3. Part below 130 mm for vehicles able to pass over shunting humps and negotiate rail brakes and other activated shunting and stopping devices

Fig. C17

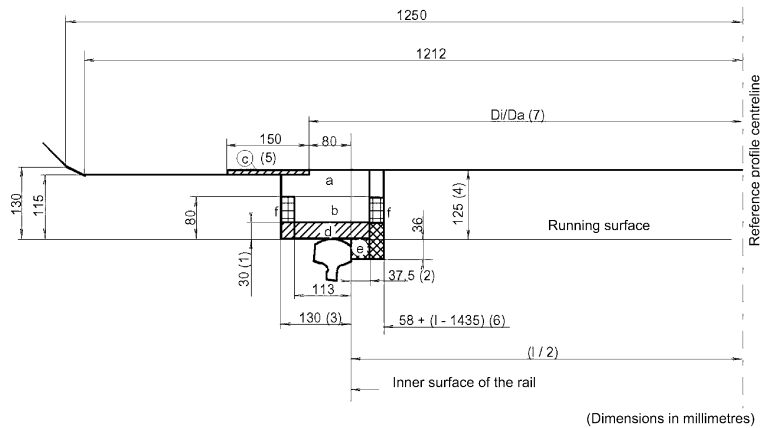

- a) zone for equipment away from wheels
  - b) zone for equipment in immediate proximity of wheels
  - c) zone for ejection of standardised drag shoes
  - d) zone for wheels and other equipment coming into contact with the rails
  - e) zone occupied exclusively by the wheels
  - f) zone for rail brakes in released position
- (1) Limit for parts located outside the axle ends (guard-irons, sanders, etc) not to be exceeded for running over detonators.
  - (2) Maximum fictional width of the flange profiles in the case of check rails.
  - (3) Effective limit position of the wheel external surface and of the parts associated with the wheel.
  - (4) This dimension also shows the maximum height of standard drag shoes used for scotching or slowing down the rolling stock.
  - (5) No rolling stock equipment should penetrate into this area.
  - (6) Effective limit position of the wheel internal surface when the axle is against the opposite rail. This dimension varies with gauge widening.
  - (7) See paragraph on 'Use of shunting devices on curved track section'.

#### C.3.2.3.1. Use of shunting devices on curved track sections

Rail brakes and other shunting and stopping devices which, when activated, can reach the dimensions 115 or 125 mm, in particular drag shoes 125 mm high, may be placed on curves of radius  $R \geq 150$  m.

Fig. C18

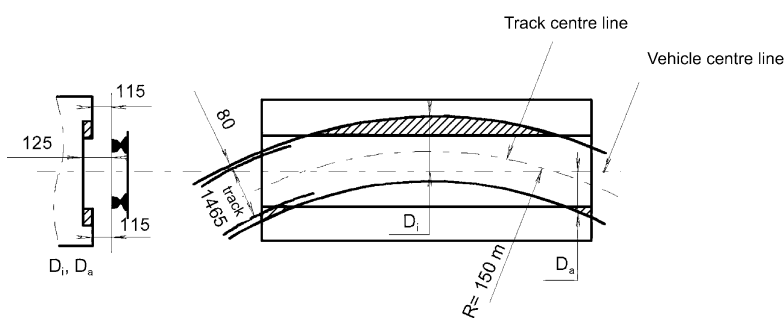

(unless otherwise indicated, dimensions are in millimetres)

## ▼ B

It follows that the application limit for the 115 or 125 mm dimensions, which is at a constant distance from the inner edge of the rail (80 mm), is at a variable distance  $D$  from the centreline of the vehicle, as shown in figure 17 above.

Take the following: <sup>(1)</sup> (values given in metres)

$$D_i = 0,008 + 1,465 - \frac{1,410}{2} + \frac{an - n^2 + \frac{p^2}{4}}{300} = 0,840 + \frac{an - n^2 + \frac{p^2}{4}}{300}$$

$$D_a = 0,008 + 1,465 - \frac{1,410}{2} + \frac{an - n^2 - \frac{p^2}{4}}{300} = 0,840 + \frac{an + n^2 - \frac{p^2}{4}}{300}$$

*NOTE:* <sup>(1)</sup> In the particular case involving the use of shunting devices, the influence of plays  $q + w$  may be considered negligible.

### C.3.3. Permitted projections $S_o$ (S)

The  $S$  effective projections must not exceed the  $S_o$  values in the table below.

$S_o$  projection values <sup>(1)</sup>

Vehicle types	Track	Ei calculation <sup>(2)</sup>		Ea calculation <sup>(2)</sup>	
		Sections between the end axles of vehicles not fitted with bogies or between the pivots of bogie vehicles		Sections beyond the end axles of vehicles not fitted with bogies or beyond the pivots of bogie vehicle	
		$h \leq 0,400$	$h > 0,400$	$h \leq 0,400$	$h > 0,400$
All powered or trailing vehicles	straight	0,015	0,015	0,015	0,015
Powered vehicles Trailing axle vehicles Bogie taken individually and their associated parts	on 250 curve	0,025	0,030	0,025	0,030
	on 150 curve	$0,025 + \frac{100 \text{ (}^2\text{)}}{750}$ = 0,1583	$0,030 + \frac{100 \text{ (}^2\text{)}}{750}$ = 0,1633	$0,025 + \frac{120 \text{ (}^2\text{)}}{750}$ = 0,185	$0,030 + \frac{120 \text{ (}^2\text{)}}{750}$ = 0,190
Trailing bogie stock or equivalent	on 250 curve	0,010	0,015	0,025	0,030
	on 150 curve	$0,010 + \frac{100 \text{ (}^2\text{)}}{750}$ = 0,1433	$0,015 + \frac{100 \text{ (}^2\text{)}}{750}$ = 0,1483	$0,025 + \frac{120 \text{ (}^2\text{)}}{750}$ = 0,185	$0,030 + \frac{120 \text{ (}^2\text{)}}{750}$ = 0,190
<p><sup>(1)</sup> These values have been calculated with the 1 track gauge which leads to the most restrictive E reduction. This value is <math>L = l_{\max.} = 1,465</math> m in all cases except for the <math>E_i</math> international reduction for trailing bogie stock or equivalent vehicles for which it is necessary to take <math>l_{\min} = 1,435</math> m. Furthermore, for powered units and railcars with one designated 'motor' bogie and one trailer bogie or bogie considered as a 'trailer' (see paragraph 7.2.2.1), the width of the track considered in the internal reduction <math>E_i</math> formulae is 1,435 m for the trailer bogie and 1,465 m for the motor bogie. However, for the sake of simplicity in calculating reductions graphically the following values may be taken for both bogies: <math>l = 1,435</math> m on straight track and 1,465 m on a 250 m curve. In this latter case, the width of the vehicle body is penalised at right angles to the trailer bogie.</p> <p><sup>(2)</sup> Term <math>x_i</math> or <math>x_a</math> in the reduction formulae.</p> <p><sup>(3)</sup> These values do not apply to the reference profile for parts on the roof.</p>					

### C.3.4. Reduction formulae

**Remark:** The formulae below must be used to calculate the gauging of articulated vehicles whose wheelset or bogie pivot centrelines coincide with the articulation centrelines of their bodies. For other articulated vehicle architectures the formulae must be adapted to the actual geometrical conditions.

#### C.3.4.1. Reduction formulae applicable to powered vehicles (dimensions in metres)

Powered vehicles for which play  $w$  is independent of the track position or varies linearly with the curvature

**Internal reductions  $E_i$**  (where  $n = n_i$ )

Sections **between** the end axles of powered vehicles not fitted with bogies or between the pivots of powered bogie vehicles.

**▼ B**

When  $an - n^2 + \frac{p^2}{4} - 500 (W_\infty - W_{i(250)}) \leq \left| \begin{matrix} 5 \\ 7,5 \end{matrix} \right. \begin{matrix} (1) \\ (2) \end{matrix}$

position on straight track preponderant:

$$E_i = \frac{1,465 - d}{2} + q + w_\infty + z - 0,015 \quad (101)$$

when  $an - n^2 + \frac{p^2}{4} - 500 (W_\infty - W_{i(250)}) > \left| \begin{matrix} 5 \\ 7,5 \end{matrix} \right. \begin{matrix} (1) \\ (2) \end{matrix}$

position on curve preponderant:

$$E_i = \frac{an - n^2 + \frac{p^2}{4}}{500} + \frac{1,465 - d}{2} + q + w_{i(250)} + z + [x_i]_{>0} - \left| \begin{matrix} 0,025 \\ 0,030 \end{matrix} \right. \begin{matrix} (1) \\ (2) \end{matrix} \quad (102)$$

$$\text{with } x_i = \frac{1}{750} \left( an - n^2 + \frac{p^2}{4} - 100 \right) + w_{i(150)} - w_{i(250)} \quad (103)$$

**External reductions  $E_a$**  (where  $n = n_a$ )

Sections beyond the end axles of powered vehicles not fitted with bogies or the pivots or powered bogie vehicles.

when  $an + n^2 - \frac{p^2}{4} - 500 \left[ (w_\infty - w_{i(250)}) \frac{n}{a} + (w_\infty - w_{a(250)}) \frac{n+a}{a} \right] \leq \left| \begin{matrix} 5 \\ 7,5 \end{matrix} \right. \begin{matrix} (1) \\ (2) \end{matrix}$

position on straight track preponderant:

$$E_a = \left( \frac{1,465 - d}{2} + q + w_\infty \right) \frac{2n + a}{a} + z - 0,015 \quad (106)$$

when  $an + n^2 - \frac{p^2}{4} - 500 \left[ (w_\infty - w_{i(250)}) \frac{n}{a} + (w_\infty - w_{a(250)}) \frac{n+a}{a} \right] > \left| \begin{matrix} 5 \\ 7,5 \end{matrix} \right. \begin{matrix} (1) \\ (2) \end{matrix}$

position on curve preponderant:

$$E_a = \frac{an + n^2 - \frac{p^2}{4}}{500} + \left( \frac{1,465 - d}{a} + q \right) \frac{2n + a}{a} + w_{i(250)} \frac{n}{a} + w_{a(250)} \frac{n+a}{a} + z + [x_a]_{>0} - \left| \begin{matrix} 0,025 \\ 0,030 \end{matrix} \right. \begin{matrix} (1) \\ (2) \end{matrix} \quad (107)$$

$$\text{with } x_a = \frac{1}{750} \left( an - n^2 - \frac{p^2}{4} - 120 \right) + (w_{i(150)} - w_{i(250)}) \frac{n}{a} + (w_{a(150)} - w_{a(250)}) \frac{n+a}{a} \quad (108)$$

**NOTES:**

- (<sup>1</sup>) This value applies to those parts no more than 0,400 m above the running surface and those which may descend below this level as a result of wear and vertical movements.
- (<sup>2</sup>) This value applies to parts located more than 0,400 m above the running surface, with the exception of those covered by footnote (1) above.

Powered units for which travel  $w$  varies non-linearly depending on the curvature (exceptional case)

— Other than curves of radius  $R$  150 and 250 m for which formulae (104), (105) and (109), (110) are identical to formulae (101), (102) and (106), (107) respectively, formulae (104), (105), (109) and (110) must be applied for the value of  $R$  for which the variation of  $w$  as a function of  $\frac{1}{R}$  shows a discontinuity; in other words the value of  $R$  as from which the variable stops come into play.

— For each section of the powered unit, the reduction to be taken is the greatest of those obtained from the application of the formulae, in which the value of  $R$  to be used is that which gives the highest value for the part between square brackets.

**▼ B****Internal reduction  $E_i$**  (where  $n = n_i$ )when  $\infty > R \geq 250$ 

$$E_i = \left[ \frac{an - n^2 + \frac{p^2}{4} - \begin{matrix} 5 \\ 7,5 \end{matrix} \begin{matrix} (1) \\ (2) \end{matrix}}{2R} + w_{i(R)} \right] + \frac{1,465 - d}{2} + q + z - 0,015 \quad (104)$$

when  $250 > R \geq 150$ 

$$E_i = \left[ \frac{an - n^2 + \frac{p^2}{4} - 100}{2R} + w_{i(R)} \right] + \frac{1,465 - d}{2} + q + z + \begin{matrix} 0,175 \\ 0,170 \end{matrix} \begin{matrix} (1) \\ (2) \end{matrix} \quad (105)^{(3)}$$

**External reduction  $E_a$**  (where  $n = n_a$ )when  $\infty > R \geq 250$ 

$$E_a = \left[ \frac{an + n^2 - \frac{p^2}{4} - \begin{matrix} 5 \\ 7,5 \end{matrix} \begin{matrix} (1) \\ (2) \end{matrix}}{2R} + w_{i(R)} \frac{n}{a} + w_{a(R)} \frac{n + a}{a} \right] + \left( \frac{1,465 - d}{2} + q \right) \frac{2n + a}{a} + z - 0,015 \quad (109)$$

when  $250 > R \geq 150$ 

$$E_a = \left[ \frac{an + n^2 - \frac{p^2}{4} - 120}{2R} + w_{i(R)} \frac{n}{a} + w_{a(R)} \frac{n + a}{a} \right] + \left( \frac{1,465 - d}{2} + q \right) \frac{2n + a}{a} + z + \begin{matrix} 0,215 \\ 0,210 \end{matrix} \begin{matrix} (1) \\ (2) \end{matrix} \quad (110)^{(3)}$$

**NOTES:**

- (<sup>1</sup>) This value applies to those parts no more than 0,400 m above the running surface and those which may descend below this level as a result of wear and vertical movements assessed.
- (<sup>2</sup>) This value applies to parts located more than 0,400 m above the running surface, with the exception of those covered by footnote (1) above.
- (<sup>3</sup>) In practice, formulae (105) and (110) are without effect, since variation of travel  $w$  takes effect when  $R > 250$  through the effect of variable stops.

C.3.4.2. *Reduction formulae applicable to multiple units (dimensions in metres)*

**For multiple units with one motor bogie and one trailer bogie (see table below)**

Multiple units fitted with:	Values of $\mu$ for each of the bogies	Running positions § 2.4.2.2	Reduction formulae
2 motor bogies	$\mu \geq 0,2$	cases 2 and 5	§ 3.4.1
2 bogies considered as 'trailer' bogies	$0 < \mu < 0,2$	cases 2 and 7	§ 3.4.3
one bogie considered as 'trailer' bogie and one trailer bogie	$0 < \mu < 0,2$ $\mu = 0$		
one motor bogie and one trailer bogie or considered as 'trailer' bogie	$\mu \geq 0,2$ $\mu = 0$ $0 < \mu < 0,2$	cases 3 and 6	§ 3.4.2 ( <sup>3</sup> ) or § 3.4.1 ( <sup>3</sup> )

**▼ B****Internal reductions  $E_i$  <sup>(4)</sup>**

Sections between bogie pivots

$$E_i = \frac{1,465 - d}{2} + q + w_\infty \frac{a - n_\mu}{a} + w'_\infty \frac{n_\mu}{a} + z - 0,015 \quad (101a)$$

$$E_i = \frac{an_\mu - n_\mu^2 + \frac{p^2}{4} \cdot \frac{a - n_\mu}{a} + \frac{p^2}{4} \cdot \frac{n_\mu}{a}}{500} + \frac{1,465 - d}{2} \cdot \frac{a - n_\mu}{a} + q + w_{i(250)} \frac{a - n_\mu}{a} + w'_{i(250)} \frac{n_\mu}{a} + z + [x_i]_{>0} - \begin{cases} 0,010 & (1) \\ 0,015 & (2) \end{cases} \frac{a - n_\mu}{a} \quad (102a)$$

$$\text{with } x_i = \frac{1}{750} \left[ an_\mu - n_\mu^2 - \frac{p^2}{4} \cdot \frac{a - n_\mu}{a} + \frac{p^2}{4} \cdot \frac{n_\mu}{a} - 100 \right] + (w_{i(150)} - w_{i(250)}) \frac{a - n_\mu}{a} + (w'_{i(150)} - w'_{i(250)}) \frac{n_\mu}{a} \quad (103a)$$

**NOTES**

- <sup>(3)</sup> The results of the formulae in paragraphs 3.4.1 and 3.4.2 are very similar; as a result, the formulae in paragraph 2.4.1 are generally employed, those of paragraph 3.4.2 being reserved for cases where the increased reduction obtained on the half-width of the maximum construction gauge is particularly significant (0 to 12,5 mm according to the vehicle section considered).
- <sup>(4)</sup> The reduction to apply for a given value of  $n$  is the greatest reduction obtained from the following formulae:
- (101 a) or (102 a) and (103 a);
  - (106 a) or (107 a) and (108 a);
  - (106 b) or (107 b) and (108 b).

**External reductions  $E_a$  <sup>(4)</sup> motor bogie end** (at the front in the running direction)Sections beyond the bogie pivots (where  $n = n_a$ )

$$E_a = \left[ \frac{1,465 - d}{2} + q \right] \frac{2n + a}{a} + w_\infty \frac{n + a}{a} + w'_\infty \frac{n}{a} + z - 0,015 \quad (106a)$$

$$E_a = \frac{an + n^2 - \frac{p^2}{4} \cdot \frac{n + a}{a} + \frac{p^2}{4} \cdot \frac{n}{a}}{500} + \frac{1,465 - d}{2} \cdot \frac{n + a}{a} + q \frac{2n + a}{a} + w'_{i(250)} \frac{n}{a} + w_{a(250)} \frac{n + a}{a} + z + [x_a]_{>0} - \begin{cases} 0,025 & (1) \\ 0,030 & (2) \end{cases} \quad (107a)$$

$$z + [x_a]_{>0} - \begin{cases} 0,025 & (1) \\ 0,030 & (2) \end{cases}$$

$$\text{with } x_a = \frac{1}{750} \left[ an + n^2 - \frac{p^2}{4} \cdot \frac{n + a}{a} + \frac{p^2}{4} \cdot \frac{n}{a} - 120 \right] + (w'_{i(150)} - w'_{i(250)}) \frac{n}{a} + (w_{a(250)} - w_{a(150)}) \frac{n + a}{a} \quad (108a)$$

$$(w_{a(250)} - w_{a(150)}) \frac{n + a}{a}$$

**External reductions  $E_a$  <sup>(4)</sup> trailer bogie end** (at the front in the running direction)Sections beyond the bogie pivots (where  $n = n_a$ )

$$E_a = \left[ \frac{1,465 - d}{2} + q \right] \frac{2n + a}{a} + w_\infty \frac{n}{a} + w'_\infty \frac{n + a}{a} + z - 0,015 \quad (106b)$$

**▼ B**

$$E_a = \frac{an + n^2 + \frac{p^2}{4} \cdot \frac{n}{a} - \frac{p^2}{4} \cdot \frac{n+a}{a}}{500} + \left( \frac{1,465-d}{2} + q \right) \frac{2n+a}{a} + w_{i(250)} \frac{n}{a} + w'_{a(250)} \frac{n+a}{a} + \quad (107b)$$

$$z + [x_a]_{>0} - \begin{matrix} 0,025 & (1) \\ 0,030 & (2) \end{matrix}$$

$$\text{with } x_a = \frac{1}{750} \left[ an + n^2 + \frac{p^2}{4} \cdot \frac{n}{a} - \frac{p^2}{4} \cdot \frac{n+a}{a} - 120 \right] + \left( w_{i(150)} - w_{i(250)} \right) \frac{n}{a} + \quad (108b)$$

$$\left( w'_{a(250)} - w'_{a(250)} \right) \frac{n+a}{a}$$

**NOTES**

- (4) The reduction to apply for a given value of n is the greatest reduction obtained from the following formulae:
- (101 a) or (102 a) and (103 a);
  - (106 a) or (107 a) and (108 a);
  - (106 b) or (107 b) and (108 b).
- (1) This value applies to those parts no more than 0,400 m above the running surface and those which may descend below this level as a result of wear and vertical movements.
- (2) This value applies to parts located more than 0,400 m above the running surface, with the exception of those covered by footnote (1) above.

C.3.4.3. *Reduction formulae applicable to coaches and passenger vehicles (dimensions in metres)*

**a) For bogie coaches, with the exception of the bogies themselves and their associated parts**

*Coaches for which the play w is independent of the track position radius or varies linearly with the track curvature*

*Note:* The formulae below must also be used to calculate the gauging of axle coaches.

**Internal reductions E<sub>i</sub>**

Sections **between** bogie pivots (where n = ni)

$$\text{When } an - n^2 + \frac{p^2}{4} - 500 (w_\infty - w_{i(250)}) \leq 250 (1,465 - d) - \begin{matrix} 2,5 & (1) \\ 0 & (2) \end{matrix}$$

the position on straight track is preponderant:

$$E_i = \frac{1,465-d}{2} + q + w_\infty + z - 0,015 \quad (201)$$

$$\text{When } an - n^2 + \frac{p^2}{4} - 500 (w_\infty - w_{i(250)}) > 250 (1,465 - d) - \begin{matrix} 2,5 & (1) \\ 0 & (2) \end{matrix}$$

the position on curved track is preponderant:

$$E_i = \frac{an - n^2 + \frac{p^2}{4}}{500} + q + w_{i(250)} + z + [x_i]_{>0} - \begin{matrix} 0,010 & (1) \\ 0,015 & (2) \end{matrix} \quad (202)$$

$$\text{with } x_i = \frac{1}{750} \left( an - n^2 + \frac{p^2}{4} - 100 \right) + w_{i(150)} - w_{i(250)} \quad (203)$$

**NOTES**

- (1) This value applies to those parts no more than 0,400 m above the running surface and those which may descend below this level as a result of wear and vertical movements.
- (2) This value applies to parts located more than 0,400 m above the running surface, with the exception of those covered by footnote (1) above.

**▼ B****External reductions E<sub>a</sub>**

Sections **beyond** bogie pivots (where  $n = na$ )

$$\text{When } an + n^2 - \frac{p^2}{4} - 500 \left[ (w_{\infty} - w_{i(250)}) \frac{n}{a} + (w_{\infty} - w_{a(250)}) \frac{n+a}{a} \right] \leq 250 (1,465 - d) \frac{n}{a} + \left|_{7,5}^{5(1)} \right. \quad (2)$$

the position on straight track is preponderant:

$$E_a = \left( \frac{1,465 - d}{2} + q + w_{\infty} \right) \frac{2n + a}{a} + z - 0,015$$

$$\text{When } an + n^2 - \frac{p^2}{4} - 500 \left[ (w_{\infty} - w_{i(250)}) \frac{n}{a} + (w_{\infty} - w_{a(250)}) \frac{n+a}{a} \right] > 250(1,465 - d) \frac{n}{a} + \left|_{7,5}^{5(1)} \right. \quad (2)$$

the position on curved track is preponderant:

$$E_a = \frac{an + n^2 - \frac{p^2}{4}}{500} + \frac{1,465 - d}{2} \cdot \frac{n+a}{a} + q \frac{2n+a}{a} + w_{i(250)} \frac{n}{a} + w_{a(250)} \frac{n+a}{a} + z + [x_a]_{>0} - \left|_{0,030}^{0,025(1)} \right. \quad (2)$$

with:

$$x_a = \frac{1}{750} \left( an + n^2 - \frac{p^2}{4} - 120 \right) + (w_{i(150)} - w_{i(250)}) \frac{n}{a} + (w_{a(150)} - w_{a(250)}) \frac{n+a}{a}$$

**NOTES**

- (1) This value applies to those parts no more than 0,400 m above the running surface and those which may descend below this level as a result of wear and vertical movements.
- (2) This value applies to parts located more than 0,400 m above the running surface, with the exception of those covered by footnote (1) above.

*Coaches for which the play w varies non - linearly with the curvature*

On straight track the reductions are calculated using formulae 201 and 206.

On curves, the reductions are calculated for  $R = 150$  m and  $R = 250$  m using formulae (204), (205), (209) and (210).

It should be noted that for a radius of  $R = 250$  m, formulae (204) and (209) are identical, respectively, to formulae (202) and (207).

Furthermore, formulae (204), (205) and (209), (210) must be applied for values of  $R$  for which the variation of  $w$ , as a function of  $\frac{1}{R}$ , presents a discontinuity (a step change), i.e. the value of  $R$  from which the variable stops come into play.

For each section of the coach, the reduction to be taken is the greatest of those resulting from the application of the above-mentioned formulae, in which the value of  $R$  to be used is that which gives the highest value for the part between square brackets.

**Internal reductions E<sub>i</sub> (where  $n = ni$ )**

When  $\infty > R \geq 250$

$$E_i = \left[ \frac{an - n^2 + \frac{p^2}{4} - \left|_{7,5}^{5(1)} \right.}{2R} + w_{i(R)} \right] + q + z \quad (204)$$

When  $250 > R \geq 150$

$$E_i = \left[ \frac{an - n^2 + \frac{p^2}{4} - 100}{2R} + w_{i(R)} \right] + q + z + \left|_{0,185}^{0,190(1)} \right. \quad (205) \quad (3)$$

**▼ B****External reductions  $E_a$  (where  $n = na$ )**When  $\infty > R \geq 250$ 

$$E_a = \left[ \frac{an + n^2 - \frac{p^2}{4} - \left| \begin{smallmatrix} 5 \\ 7,5 \end{smallmatrix} \right. \begin{smallmatrix} (1) \\ (2) \end{smallmatrix}}{2R} + w_{i(R)} \frac{n}{a} + w_{a(R)} \frac{n+a}{a} \right] + \frac{1,465-d}{2} \cdot \frac{n+a}{a} + q \frac{2n+a}{a} + z - 0,015 \quad (209)$$

When  $250 > R \geq 150$ 

$$E_a = \left[ \frac{an + n^2 - \frac{p^2}{4} - 120}{2R} + w_{i(R)} \frac{n}{a} + w_{a(R)} \frac{n+a}{a} \right] + \frac{1,465-d}{2} \cdot \frac{n+a}{a} + q \frac{2n+a}{a} + z + \left| \begin{smallmatrix} 0,215 \\ 0,210 \end{smallmatrix} \right. \begin{smallmatrix} (1) \\ (2) \end{smallmatrix} \quad (210)^{(3)}$$

**NOTES**

- (1) This value applies to those parts no more than 0,400 m above the running surface and those which may descend below this level as a result of wear and vertical movements.
- (2) This value applies to parts located more than 0,400 m above the running surface, with the exception of those covered by footnote (1) above.
- (3) In practice, formulae (205) and (210) have no effect, since the variation in play  $w$ , resulting from the variable stops taking effect, begins only when  $R > 250$ .

**b) For bogies and their associated parts**

The reduction formulae to be applied are those given in § 4.2.1.8.2. Nonetheless, the distance between the end axles of the bogies is in most cases such that formulae (201) and (206) opposite, identical to formulae (101) and (106), are applicable.

**C.3.4.4. Reduction formulae applicable to wagons (dimensions in metres)****a) For wagons with independent axles and the bogies themselves and their associated parts ( $w = 0$ )**

For 2-axle wagons, and only for those parts located below 1,17 m above the running surface, term  $Z$  in formulae (301) to (307) may be reduced by 0,005 m when  $(z-0,005) > 0$ . It shall be considered nil when  $(z-0,005) \leq 0$ .

**1) Internal reductions  $E_i$  — Sections between the end axles (where  $n = ni$ )**When  $an - n^2 \leq \left| \begin{smallmatrix} 5 \\ 7,5 \end{smallmatrix} \right. \begin{smallmatrix} (1) \\ (2) \end{smallmatrix}$  the position on straight track is preponderant:

$$E_i = \frac{1,465-d}{2} + q + w_\infty + z - 0,015 \quad (301)$$

When  $an - n^2 > \left| \begin{smallmatrix} 5 \\ 7,5 \end{smallmatrix} \right. \begin{smallmatrix} (1) \\ (2) \end{smallmatrix}$  the position on curved track is preponderant:

$$E_i = \frac{an - n^2}{500} + \frac{1,465-d}{2} + q + z - \left| \begin{smallmatrix} 0,025 \\ 0,030 \end{smallmatrix} \right. \begin{smallmatrix} (1) \\ (2) \end{smallmatrix} \quad (302)$$

**2) External reductions  $E_a$  — Sections beyond the end axles (where  $n = na$ )**When  $an + n^2 \leq \left| \begin{smallmatrix} 5 \\ 7,5 \end{smallmatrix} \right. \begin{smallmatrix} (1) \\ (2) \end{smallmatrix}$  the position on straight track is preponderant:

$$E_a = \left( \frac{1,465-d}{2} \right) \frac{2n+a}{a} + z - 0,015 \quad (306)$$



**▼ B**

When  $an + n^2 > \left|_{7,5}^{5(1)}\right.$  the position on curved track is preponderant:

$$E_a = \frac{an + n^2}{500} + \left( \frac{1,465 - d}{2} + q \right) \frac{2n + a}{a} + z - \left|_{0,030}^{0,025(1)}\right. \quad (307)$$

*NOTES*

- (<sup>1</sup>) This value applies to those parts no more than 0,400 m above the running surface and those which may descend below this level as a result of wear and vertical movements.
- (<sup>2</sup>) This value applies to parts located more than 0,400 m above the running surface, with the exception of those covered by footnote (1) above.

**b) For bogie wagons**

For bogie wagons whose play is considered to be constant, except for the bogies themselves and their associated parts.

Special remark for calculation of z: see § 1.5.1.3.

1) - Internal reductions  $E_i$  — Sections between bogie pivots (where  $n = ni$ )

When  $an - n^2 + \frac{p^2}{4} \leq 250(1,465 - d) - \left|_{0}^{2,5(1)}\right.$  the position on straight track is preponderant:

$$E_i = \frac{1,465 - d}{2} + q + w_\infty + z - 0,015 \quad (311)$$

When  $an - n^2 + \frac{p^2}{4} > 250(1,465 - d) - \left|_{0}^{2,5(1)}\right.$  the position on curved track is preponderant:

$$E_i = \frac{an - n^2 + \frac{p^2}{4}}{500} + q + w + z + [x_i]_{>0} - \left|_{0,015}^{0,010(1)}\right. \quad (312)$$

$$\text{with } x_i = \frac{1}{750} \left( an - n^2 + \frac{p^2}{4} - 100 \right) \quad (313)$$

2) External reductions  $E_a$  — Sections beyond bogie pivots (where  $n = na$ )

When  $an + n^2 - \frac{p^2}{4} \leq 250(1,465 - d) \frac{n}{a} + \left|_{7,5}^{5(1)}\right.$  the position on straight track is preponderant:

$$E_a = \left( \frac{1,465 - d}{2} + q + w \right) \frac{2n + a}{a} + z - 0,015 \quad (316)$$

When  $an + n^2 - \frac{p^2}{4} > 250(1,465 - d) \frac{n}{a} + \left|_{7,5}^{5(1)}\right.$  the position on curved track is preponderant:

$$E_a = \frac{an + n^2 - \frac{p^2}{4}}{500} + \frac{1,465 - d}{2} \cdot \frac{n + a}{a} + (q + w) \frac{2n + a}{a} + \quad (317)$$

$$z + [x_a]_{>0} + \left|_{0,030}^{0,025(1)}\right.$$

▼ **B**

$$\text{with } x_i = \frac{1}{750} \left( an + n^2 - \frac{p^2}{4} - 120 \right) \quad (318)$$

**NOTES**

- (1) This value applies to those parts no more than 0,400 m above the running surface and those which may descend below this level as a result of wear and vertical movements.
- (2) This value applies to parts located more than 0,400 m above the running surface, with the exception of those covered by footnote (1) above.

**C.3.5. Reference profile for pantographs and non-insulated live parts on the roof**

Figure 19

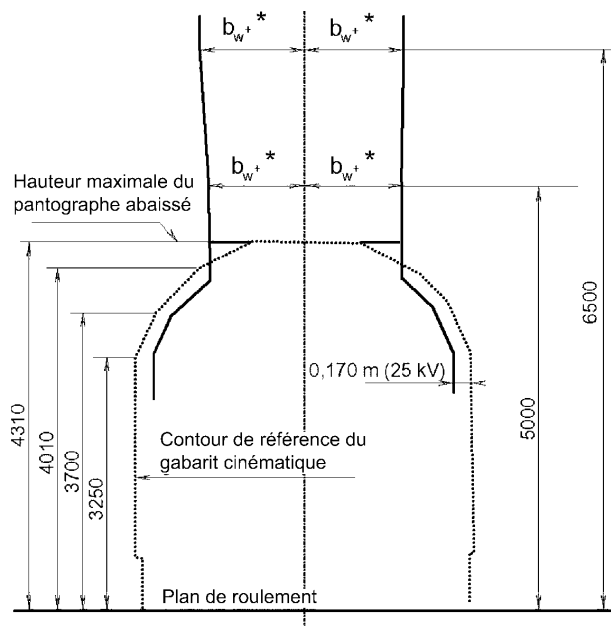

Sauf indication contraire, cotes exprimées en millimètres

$b_w$  = demi largeur de l'archet

\* = déplacements autorisés. Ces déplacements sont respectés lorsque les conditions des formules (111) (112) (113) ou (114) pour  $h = 6,5$  m et (115) (116) (117) ou (118) pour  $h = 5$  m, sont remplies

□ Espaces dans lesquels ne doivent pas pénétrer les organes non isolés susceptibles de rester sous tension

*Note:* For vehicles worked on electrified lines, the shaded areas may be used for gauging pantograph bows in the down position.

On non electrified lines, the same possibilities are allowable subject to specific studies by the railways.

**C.3.6. Rules for the reference profile for determining the maximum rolling stock construction gauge**

**C.3.6.1. Powered units fitted with pantographs**

Pantograph in current collection position

The present standard is based on the characteristics of pantographs for standard gauge powered units.

In order for powered units with pantographs to respect the limit position resulting from the reference profile, the characteristics of these vehicles (play and coef-

**▼ B**

ficient of flexibility of the pantograph-bearing section) and the position of the pantograph in relation to the axles must be such that the quantities  $E'_i$  and  $E'_a$  (with pantographs raised to 6,5 m above the running surface) and  $E''_i$  and  $E''_a$  (pantographs raised to 5 m above the running surface) are negative or nil.

This condition is met if the section in which the pantograph bow is operated is placed close to the transverse centreline of the bogies, i.e. if  $n$  is very small or nil.

The limit position is then defined by the reference profile for roof-mounted equipment shown in paragraph 2.5. It corresponds to a maximum geometric overthrow of the pantograph bow of  $\frac{2,5}{R}$ .

## a) Preliminary calculations

To determine  $E'_i$ ,  $E'_a$ ,  $E''_i$  and  $E''_a$ , the following preliminary calculations are necessary <sup>(1)</sup> 1):

$$j'_i = q + w_i - 0,0375 \quad (2) \quad 2)$$

$$j'_a = q \frac{2n + a}{a} + w_a \frac{n + a}{a} + w_i \frac{n}{a} - 0,0375 \quad (2)$$

when  $s \leq 0,225$  (general case)

$$z' = \frac{8}{30}(s - 0,225) + (t - 0,03) + (\tau - 0,01) + 6(\theta - 0,005)$$

but if  $s > 0,225$ , this implies a value of

$$z' = \frac{8}{10}(s - 0,225) + (t - 0,03) + (\tau - 0,01) + 6(\theta - 0,005)$$

when  $s \leq 0,225$  (general case)

$$z'' = \frac{6}{30} s + \sqrt{\left(t \frac{h - h_t}{6,5 - h_t}\right)^2 + \tau^2 + (\theta(h - h_c))^2} - 0,0925$$

but if  $s > 0,225$ , this implies a value of

$$z'' = \frac{6}{10} s + \sqrt{\left(t \frac{h - h_t}{6,5 - h_t}\right)^2 + \tau^2 + (\theta(h - h_c))^2} - 0,1825$$

## b) For sections between the end axles or bogie pivots

Expressions for  $E'_i$  and  $E''_i$  (where  $n = n_i$ )

When  $an - n^2 + \frac{p^2}{4} \leq 5$  the position on straight track is preponderant:

$$h = 6,5 \text{ m} \quad E'_i = j'_i + z' \quad (111)$$

$$h = 5 \text{ m} \quad E''_i = j'_i + z'' \quad (115)$$

When  $an - n^2 + \frac{p^2}{4} > 5$  the position on curved track is preponderant:

$$h = 6,5 \text{ m} \quad E'_i = \frac{an - n^2 + \frac{p^2}{4} - 5}{300} + j'_i + z' \quad (112)$$

$$h = 5 \text{ m} \quad E''_i = \frac{an - n^2 + \frac{p^2}{4} - 5}{300} + j'_i + z'' \quad (116)$$

## c) For sections beyond the end axles or bogie pivots

Expressions for  $E'_a$  and  $E''_a$  (where  $n = n_a$ )

When  $an - n^2 + \frac{p^2}{4} \leq 5$  the position on straight track is preponderant:

$$h = 6,5 \text{ m} \quad E'_a = j'_a + z' + \frac{1,465 - d}{2} \cdot \frac{2n}{a} \quad (113)$$

<sup>(1)</sup> For powered units without fixed bogie pivots, see note in § 1.1.

<sup>(2)</sup> If the play varies according to the track position radius, the maximum value of  $w_i$  at pivot level (actual or theoretical) shall be taken from  $j'_i$ , and the maximum value of  $w_a$  and the corresponding value of  $w_i$  taken from  $j'_a$ .

**▼ B**

$$h = 5 \text{ m} \quad E''_a = j'_a + z'' + \frac{1,465 - d}{2} \cdot \frac{2n}{a} \quad (117)$$

When  $an - n^2 + \frac{p^2}{4} > 5$  the position on curved track is preponderant:

$$h = 6,5 \text{ m} \quad E'_a = \frac{an + n^2 - \frac{p^2}{4} - 5}{300} + j'_a + z' + \frac{1,465 - d}{2} \cdot \frac{2n}{a} \quad (114)$$

$$h = 5 \text{ m} \quad E''_a = \frac{an + n^2 - \frac{p^2}{4} - 5}{300} + j'_a + z'' + \frac{1,465 - d}{2} \cdot \frac{2n}{a} \quad (118)$$

#### C.3.6.2. *Railcars fitted with pantographs*

The limit position for pantographs on a railcar with one motor bogie and one trailer bogie shall be determined as if both bogies were identical to the one above which the pantograph is placed.

#### C.3.6.3. *Pantographs in lowered position*

Subject, if necessary, to application of the insulation conditions, the lowered pantograph must fall entirely within the gauge defined.

#### C.3.6.4. *Insulation clearance margin for 25kV*

On vehicles which may use a 25 kV power supply, all non-insulated parts likely to remain live must be arranged so as to fall well within the 0,170 m reference profile.

### C.4. GA, GB, GC VEHICLE GAUGES

By comparison with the G1 gauge, the GA, GB and GC gauges are larger in the upper part.

Loads and vehicles conforming to enlarged gauges GA, GB or GC shall only be allowed on lines widened to these gauges. The lines concerned are listed in the Infrastructure Register. All GA, GB and GC movements on lines not shown on this list shall be treated as special consignments.

Wagons and coaches built to gauges GA, GB or GC shall be identified by a marking as specified in Annex B 32

#### C.4.1. **Static gauge reference profiles and associated rules**

The reference profiles for the static gauges GA GB and GC (see Fig. 20), together with their associated rules, apply exclusively to determining the maximum load profiles and on the condition that the coefficient of flexibility of the wagon + its load is not greater than that of the typical load considered, having the following characteristics:

$$q+w = 0,023\text{m}; p = 1,8\text{m}; d = 1,41\text{m};$$

$$J = 0,005\text{m} \quad \eta_0 < 1^\circ \quad h_C = 0,5\text{m}$$

$$s = 0,3$$

vertical oscillations 0,03m (GA, GB); 0,05m (GC)

In view of tolerances on centring, the half-widths should be at most equal to those of the reference profiles reduced by the following values  $E_i$  and  $E_a$ .

▼ B

## REFERENCE PROFILES FOR STATIC GAUGES GA, GB and GC (load gauges)

Fig. C20

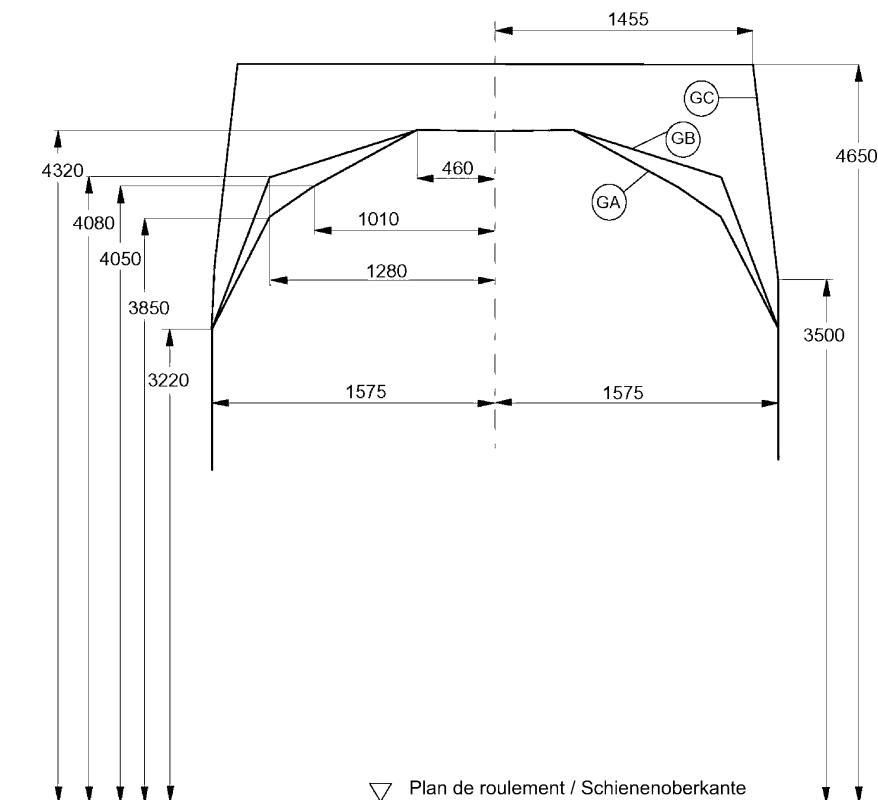

Note: Up to a height of 3 220 mm, the reference profile of the GA, GB and GC gauges is identical to that of the G1 gauge.

C.4.1.1. *GA and GB static gauges*

— **Height  $h \leq 3,22$  m.** The  $E_i$  and  $E_a$  reduction formulae to be applied are those associated with the G1 static gauge.

— **Height  $h > 3,22$  m.** The  $E_i$  and  $E_a$  reduction formulae to be applied are as follows:

a) For the sections between the bogie pivots or between the end axles of vehicles not mounted on bogies

$$\text{When } \left( an - n^2 + \frac{p^2}{4} \right) \leq 7,5 + 32,5k \quad \Delta_i = 7,5 + 32,5k$$

$$\text{When } \left( an - n^2 + \frac{p^2}{4} \right) > 7,5 + 32,5k \quad \Delta_i = an - n^2 + \frac{p^2}{4}$$

$$E_i = \left[ \frac{\Delta_i}{500} + \frac{1,465 - d}{2} + q + w + x_{i>0} - 0,075 - 0,065k \right]_{>0} \quad (601)$$

$$\text{with } x_i = \frac{1}{750} \left( an - n^2 + \frac{p^2}{4} - 100 \right);$$

**▼B**

$k =$  (see Table 1)

- b) For sections beyond the bogie pivots or the end axles of vehicles not mounted on bogies

$$\text{When } \left( an + n^2 - \frac{p^2}{4} \right) \leq 7,5 + 32,5k \Delta_a = 7,5 + 32,5k$$

$$\text{When } \left( an + n^2 - \frac{p^2}{4} \right) > 7,5 + 32,5k \Delta_a = an + n^2 - \frac{p^2}{4}$$

$$E_a = \left[ \frac{\Delta_a}{500} + \left( \frac{1,465 - d}{2} + q + w \right) \frac{2n + a}{a} + x_{a>0} - 0,075 - 0,065k \right]_{>0} \quad (602)$$

$$\text{with } x_a = \frac{1}{750} \left( an + n^2 - \frac{p^2}{4} - 100 \right);$$

$k =$  (see Table 1)

TABLE 1:

GA GAUGE

$$\text{if } 3,22 < h < 3,85 \text{ m, } k = \frac{h - 3,22}{0,63}$$

$$\text{if } h \geq 3,85 \text{ m, } k = 1$$

GB GAUGE

$$\text{if } 3,22 < h < 4,08 \text{ m, } k = \frac{h - 3,22}{0,86}$$

$$\text{if } h \geq 4,08 \text{ m, } k = 1$$

#### C.4.1.2. *GC static gauge*

The  $E_i$  and  $E_a$  reduction formulae to be applied are those associated with the G1 static gauge irrespective of the value of  $h$ .

#### C.4.2. **Kinematic gauge reference profiles and associated rules**

The GA, GB and GC kinematic gauge reference profiles (see Fig. 21) taken with their associated rules allow to determine the maximum construction profile for vehicles in the same way as when using the G1 gauge.

The rules for the kinematic calculations may be applied to clearly defined loads.

The term ‘clearly defined loads’ shall be understood to mean: transferable unit loads of known geometry, e.g. containers and swap bodies conveyed on carrier wagons fitted with load positioning devices, and semi-trailers with deflated air suspension or mechanical suspension with a known roll flexibility coefficient and conveyed on recess wagons.

Under these conditions the combination of a wagon and its load can be treated as a normal single wagon.

Reference profiles for GA, GB and GC kinematic gauges

▼B

Fig. C21

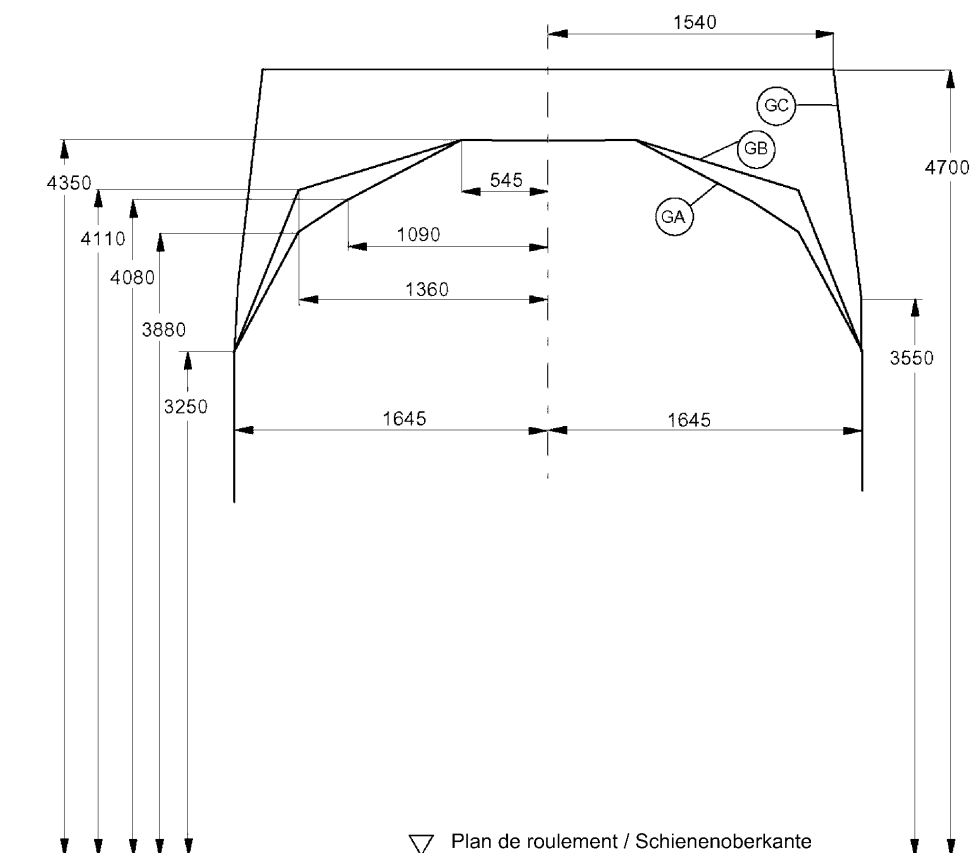

Note: Up to a height of 3 220 mm, the reference profile of the GA, GB and GC gauges is identical to that of the G1 gauge.

C.4.2.1. *Tractive units (except railcars and multiple unit motor coaches)*

C.4.2.1.1. GA and GB kinematic gauges

— **Height  $h \leq 3,25\text{m}$ .** The formulae to be applied are those associated with the G1 profile.

— **Height  $h > 3,25\text{m}$ .** The formulae to be applied are those associated with the G1 profile, with the exception of the formulae given under cases a) and b) below.

a) Vehicles for which the play  $w$  is independent of the track position radius or varies linearly with the track curvature

1) For sections **between** the bogie pivots or between the end axles of vehicles not mounted on bogies

$$\text{When } an - n^2 + \frac{p^2}{4} - 500(W_\infty - W_{i(250)}) \leq 7,5 + 32,5k$$

$$E_i = \frac{1,465 - d}{2} + q + w_\infty + z - 0,015 \quad (603)$$

$$\text{When } an - n^2 + \frac{p^2}{4} - 500(W_\infty - W_{i(250)}) > 7,5 + 32,5k$$

$$E_i = \frac{an - n^2 + \frac{p^2}{4}}{500} + \frac{1,465 - d}{2} + q + w_{i(250)} + x_{i>0} - 0,030 - 0,065k \quad (604)$$

$$\text{with } x_i = \frac{1}{750} \left( an - n^2 + \frac{p^2}{4} - 100 \right) + w_{i(150)} - w_{i(250)}$$

$k$  and  $z$  = (see table 2)

**▼ B**

- 2) For sections **beyond** the bogie pivots or the end axles of vehicles not mounted on bogies

$$\text{When } an + n^2 - \frac{p^2}{4} - 500 \left[ (w_\infty - w_{i(250)}) \frac{n}{a} + (w_\infty - w_{i(250)}) \frac{n+a}{a} \right] \leq 7,5 + 32,5k$$

$$E_a = \left( \frac{1,465-d}{2} + q + W_\infty \right) \frac{2n+a}{a} + z - 0,015 \quad (605)$$

When

$$an + n^2 - \frac{p^2}{4} - 500 \left[ (W_\infty - W_{i(250)}) \frac{n}{a} + (W_\infty - W_{i(250)}) \frac{n+a}{a} \right] > 7,5 + 32,5k$$

$$E_a = \frac{an + n^2 - \frac{p^2}{4}}{500} + \left( \frac{1,465-d}{2} + q \right) \frac{2n+a}{a} + w_{i(250)} \frac{n}{a} + W_{a(250)} \frac{n+a}{a} + z + x_{a>0} - 0,030 - 0,065k \quad (606)$$

with

$$x_a = \frac{1}{750} \left( an + n^2 - \frac{p^2}{4} - (120 - 20k) \right) + (W_{i(150)} - W_{i(250)}) \frac{n}{a} + (W_{a(150)} - W_{a(250)}) \frac{n+a}{a}$$

$k$  and  $z$  = (see table 2)

**b) Vehicles for which the play  $w$  varies non-linearly with the track curvature**

- 1) For sections **between** the bogie pivots or the end axles of vehicles not mounted on bogies

For each point of the vehicle, the value of  $E_i$  to be taken is the

greatest obtained from application of:

— formula (603) above

— formulae (607) and (608) below in which the value of  $R$  to be taken maximises the portion between the square brackets

$$E_i = \left[ \frac{an - n^2 + \frac{p^2}{4} - (7,5 + 32,5k)}{2R} + w_{i(R)} \right] + \frac{1,465-d}{2} + q + z - 0,015 \quad (607)$$

with  $\infty > R \geq 250$  m

$$E_i = \left[ \frac{an - n^2 + \frac{p^2}{4} - 100}{2R} + w_{i(R)} \right] + \frac{1,465-d}{2} + q + z - 0,170 - 0,065k \quad (608)$$

with  $250 > R \geq 150$  m

$k$  and  $z$  = (see table 2)

- 2) For sections **beyond** the bogie pivots or the end axles of vehicles not mounted on bogies

For each point on the vehicle, the value of  $E_a$  to be taken is the greatest obtained from application of:

— formula (605) above

formulae (609) and (610) below in which the value of  $R$  to be taken maximises the portion between the square brackets



**▼B**

$$E_a = \left[ \frac{an + n^2 - \frac{p^2}{4} - (7,5 + 32,5k)}{2R} + w_{i(R)} \frac{n}{a} + W_{a(R)} \frac{n+a}{a} \right] + \left( \frac{1,465-d}{2} + q \right) \frac{2n+a}{a} + \quad (609)$$

$z - 0,015$

with  $\infty > R \geq 250$  m

$$E_a = \left[ \frac{an + n^2 - \frac{p^2}{4} - (120 - 20k)}{2R} + w_{i(R)} \frac{n}{a} + W_{a(R)} \frac{n+a}{a} \right] + \left( \frac{1,465-d}{2} + q \right) \frac{2n+a}{a} + \quad (610)$$

$z - 0,210 - 0,105k$

with  $250 > R \geq 150$  m

$k$  and  $z$  = (see table 2)

TABLE 2:

GA GAUGE

if  $3,25 < h < 3,38$ ,  $k = \frac{h - 3,25}{0,63}$

if  $h \geq 3,38$  m,  $k = 1$

GB GAUGE

if  $3,25 < h < 4,11$ ,  $k = \frac{h - 3,25}{0,86}$

if  $h \geq 4,11$  m,  $k = 1$

$$z = \left[ \frac{s}{30} + \tan(\eta_0 - 1^\circ)_{>0} \right] (h - h_c) + \left[ \frac{s}{10} (h - h_c) - (0,04 - 0,01k)(h - 0,5) \right]_{>0}$$

C.4.2.1.2. GC kinematic gauge

The formulae to be applied are those associated with the G1 profile, irrespective of the value of  $h$ .

C.4.2.2. Railcars and multiple unit motor coaches

*Note:* The gauge characteristics of railcars and multiple unit motor coaches whose bogies can be considered to be motor or trailer bogies are described in § 3.4.2.

C.4.2.2.1. GA and GB kinematic gauges

- **Height  $h \leq 3,25$ m.** The formulae to be applied are those associated with the G1 profile.
- **Height  $h > 3,25$ m.** The formulae to be applied are those associated with the G1 profile with the exception of the following formulae:
  - Railcars and MU motor coaches with all bogies considered as powered: the formula are those given in § 3.4.1 (Traction units)
  - Railcars and MU motor coaches considered to have only trailer bogies: the formulae are those given in § 3.4.3 (Passenger coaches and luggage vans)
  - Railcars with a motor bogie and a trailer bogie: the reduction formulae given in 3.4.1 may either be applied as they stand, or replaced by the following

▼ **B**

formulae which offer manufacturers slight advantages in the centre-part and at the ends of the vehicle body.

a) Between the pivots <sup>(1)</sup>

$$E_i = \frac{1,465 - d}{2} + q + w_\infty \frac{a - n_\mu}{a} + w'_\infty \frac{n_\mu}{a} + z - 0,015 \quad (603a)$$

$$E_i = \frac{an_\mu + n_\mu^2 + \frac{p^2}{4} \cdot \frac{a - n_\mu}{a} + \frac{p'^2}{4} \cdot \frac{n_\mu}{a}}{500} + \frac{1,465 - d}{2} \cdot \frac{a - n_\mu}{a} + q + w_{i(250)} \frac{a - n_\mu}{a} + w'_{i(250)} \frac{n_\mu}{a} + z + x_{i>0} - 0,015 - 0,015 \frac{a - n_\mu}{a} - 0,065k \quad (604a)$$

$$\text{with } x_i = \frac{1}{750} \left( an_\mu - n_\mu^2 + \frac{p^2}{4} \cdot \frac{a - n_\mu}{a} + \frac{p'^2}{4} \cdot \frac{n_\mu}{a} - 100 \right) + (w_{i(150)} - w_{i(250)}) \frac{a - n_\mu}{a} + (w'_{i(250)} - W'_{i(150)}) \frac{n_\mu}{a}$$

$k$  and  $z$  = (see table 2)

b) Beyond the pivots on the motor bogie side <sup>(1)</sup>

$$E_a = \left( \frac{1,465 - d}{2} + q + w_\infty \right) \frac{2n + a}{a} + z - 0,015 \quad (605b)$$

$$E_a = \frac{an + n^2 - \frac{p^2}{4} \cdot \frac{n + a}{a} + \frac{p'^2}{4} \cdot \frac{n}{a}}{500} + \frac{1,465 - d}{2} \cdot \frac{n + a}{a} + q \frac{2n + a}{a} + w'_{i(250)} \frac{n}{a} + w'_{a(250)} \frac{n + a}{a} + z + x_{i>0} - 0,030 - 0,065k \quad (606b)$$

with

$$x_a = \frac{1}{750} \left( an + n^2 + \frac{p^2}{4} \cdot \frac{n}{a} - \frac{p'^2}{4} \cdot \frac{n + a}{a} - (120 - 20k) \right) + (w_{i(150)} - w_{i(250)}) \frac{n}{a} + (w'_{a(150)} - W'_{a(250)}) \frac{n + a}{a}$$

$k$  and  $z$  = (see Table 2)

## NOTES

- <sup>(1)</sup> This value applies to those parts no more than 0,400 m above the running surface and those which may descend below this level as a result of wear and vertical movements.

## C.4.2.2.2. GC kinematic gauge

The formulae to be applied are those associated with the G1 profile, irrespective of the value of  $h$ .

## C.4.2.3. Passenger coaches and luggage vans

## C.4.2.3.1. GA and GB kinematic gauges

— **Height  $h \leq 3,25m$ .** The formulae to be applied are those associated with the G1 profile.

— **Height  $h > 3,25m$ .** The formulae to be applied are those associated with the G1 profile, with the exception of the formulae given under cases a) and b) below.

a) Vehicles for which the play  $w$  is independent of the track position radius or varies linearly with the track curvature

1) For sections **between** the bogie pivots

$$\text{When } an - n^2 + \frac{p^2}{4} - 500(W_\infty - W_{i(250)}) \leq 250 (1,465 - d) + 32,5k$$

$$E_i = \left( \frac{1,465 - d}{2} + q + w + z - 0,015 \right) \quad (611)$$

<sup>(1)</sup> The reduction to be applied for the same value of  $n$  is the greatest obtained with formula (603a) and (604a)

**▼ B**

When  $an - n^2 + \frac{p^2}{4} - 500(w_\infty - w_{i(250)}) > 250(1,465-d) + 32,5k$

$$E_i = \frac{an - n^2 + \frac{p^2}{4}}{500} + q + w_{i(250)} + z + x_{i>0} - 0,015 - 0,065k \quad (612)$$

with  $x_a = \frac{1}{750} \left( an - n^2 + \frac{p^2}{4} - 100 \right) + w_{i(150)} - w_{i(250)}$

$k$  and  $z$  = (see table 3)

2) For sections **beyond** the bogie pivots

When

$$an + n^2 - \frac{p^2}{4} - 500 \left[ (w_\infty - w_{i(250)}) \frac{n}{a} + (w_\infty - w_{i(250)}) \frac{n+a}{a} \right] \leq 250(1,465-d) \frac{n}{a} + (7,5 + 32,5k)$$

$$E_a = \left( \frac{1,465-d}{2} + q + w_\infty \right) \frac{2n+a}{a} + z - 0,015 \quad (613)$$

When

$$an + n^2 - \frac{p^2}{4} - 500 \left[ (w_\infty - w_{i(250)}) \frac{n}{a} + (w_\infty - w_{a(250)}) \frac{n+a}{a} \right] > 250(1,465-d) \frac{n}{a} + (7,5 + 32,5k)$$

$$E_a = \frac{an + n^2 - \frac{p^2}{4}}{500} + \frac{1,465-d}{2} \cdot \frac{n+a}{a} + q \frac{2n+a}{a} + w_{i(250)} \frac{n}{a} + w_{a(250)} \frac{n+a}{a} + z + x_{a>0} - 0,030 - 0,065k \quad (614)$$

with  $x_a = \frac{1}{750} \left( an + n^2 - \frac{p^2}{4} - (120 - 20k) \right) + (w_{i(150)} - w_{i(250)}) \frac{n}{a} + (w_{a(150)} - w_{a(250)}) \frac{n+a}{a}$

$k$  and  $z$  = (see table 3)

b) Vehicles for which the play  $w$  varies non-linearly with the track curvature1) For sections **between** the bogie pivots

For each point on the vehicle, the value of  $E_i$  to be taken is the greatest obtained from application of:

— formula (611) above

— formulae (615) and (616) below in which the value of  $R$  to be taken maximises the portion between the square brackets

$$E_i = \left[ \frac{an - n^2 + \frac{p^2}{4} - (7,5 + 32,5k)}{2R} + w_{i(R)} \right] + q + z \quad (615)$$

with  $\infty > R \geq 250$  m

$$E_i = \left[ \frac{an - n^2 + \frac{p^2}{4} - 100}{2R} + w_{i(R)} \right] + q + z + 0,185 - 0,065k \quad (616)$$

with  $250 > R \geq 150$  m

$k$  and  $z$  = (see table 3)

**▼B**

2) For sections **beyond** the bogie pivots

For each point on the vehicle, the value of  $E_a$  to be taken is the greatest obtained from application of:

— formula (613) above

— formulae (617) and (618) below in which the value of  $R$  to be taken maximises the portion between the square brackets

$$E_a = \left[ \frac{an + n^2 - \frac{p^2}{4} - (7,5 - 32,5k)}{2R} + w_{i(R)} \frac{n}{a} + w_{a(R)} \frac{n+a}{a} \right] + \frac{1,465-d}{2} \cdot \frac{n+a}{a} + \quad (617)$$

$$q \frac{2n+a}{a} + z - 0,015$$

with  $\infty > R \geq 250$  m

$$E_a = \left[ \frac{an + n^2 - \frac{p^2}{4} - (120 - 20k)}{2R} + w_{i(R)} \frac{n}{a} + w_{a(R)} \frac{n+a}{a} \right] + \frac{1,465-d}{2} \cdot \frac{n+a}{a} + \quad (618)$$

$$q \cdot \frac{2n+a}{a} + z - 0,120 - 0,105k$$

with  $250 > R \geq 150$  m

$k$  and  $z$  = (see Table 3)

TABLE 3:

GA GAUGE

$$\text{if } 3,25 < h < 3,88 \text{ m, } k = \frac{h - 3,25}{0,63}$$

if  $h \geq 3,88$  m,  $k = 1$

GB GAUGE

$$\text{if } 3,25 < h < 4,11 \text{ m, } k = \frac{h - 3,25}{0,86}$$

if  $h \geq 4,11$  m,  $k = 1$

$$z = \left[ \frac{s}{30} + \tan(\eta_0 - 1^\circ) \right]_{>0} (h - h_c) + \left[ \frac{s}{10} (h - h_c) - (0,04 - 0,01k)(h - 0,5) \right]_{>0}$$

C.4.2.3.2. GC kinematic gauge

The formulae to be applied are those associated with the G1 profile, irrespective of the value of  $h$ .

C.4.2.4. Wagons

C.4.2.4.1. GA and GB kinematic gauges

— **Height  $h \leq 3,25$  m.** The formulae to be applied are those associated with the G1 profile.

— **Height  $h > 3,25$  m.** The formulae to be applied are those associated with the G1 profile, with the exception of the formulae given under cases a) and b) below.

a) Vehicles not mounted on bogies

For sections **between** end axles

When  $an - n^2 \leq 7,5 + 32,5 k$

$$E_i = \frac{1,465-d}{2} + q + w_\infty + z - 0,015 \quad (619)$$

**▼B**

When  $an - n^2 \leq 7,5 + 32,5 k$

$$E_i = \frac{an - n^2}{500} + \frac{1,465 - d}{2} + q + w + z - 0,030 - 0,065k \quad (620)$$

with  $k$  and  $z$  = (see Table 4)

For sections **beyond** the end axles

When  $an + n^2 \leq 7,5 + 32,5 k$

$$E_a = \left( \frac{1,465 - d}{2} + q + w \right) \frac{2n + a}{a} + z - 0,015 \quad (621)$$

When  $an + n^2 > 7,5 + 32,5 k$

$$E_i = \frac{an - n^2}{500} + \left( \frac{1,465 - d}{2} + q + w \right) \frac{2n + a}{a} + z - 0,030 - 0,065k \quad (622)$$

with  $k$  and  $z$  = (see Table 4)

b) Bogie vehicles

For sections **between** the bogie pivots

When  $an - n^2 + \frac{p^2}{4} \leq 250(1,465 - d) + 32,5k$

$$E_i = \frac{1,465 - d}{2} + q + w + z - 0,015 \quad (623)$$

When  $an - n^2 + \frac{p^2}{4} > 250(1,465 - d) + 32,5k$

$$E_i = \frac{an + n^2 - \frac{p^2}{4}}{500} + q + w_{i(250)} + z + x_{i>0} - 0,015 - 0,065k \quad (624)$$

with  $x_i = \frac{1}{750} \left( an - n^2 + \frac{p^2}{4} - 100 \right) + w_{i(150)} - w_{i(250)}$

$k$  and  $z$  = (see Table 4)

For sections **beyond** the bogie pivots

When  $an + n^2 - \frac{p^2}{4} \leq 250(1,465 - d) \frac{n}{a} + (7,5 + 32,5k)$

$$E_a = \left( \frac{1,465 - d}{2} + q + w_\infty \right) \frac{2n + a}{a} + z - 0,015 \quad (625)$$

When  $an + n^2 - \frac{p^2}{4} > 250(1,465 - d) \frac{n}{a} + (7,5 + 32,5k)$

$$E_a = \frac{an + n^2 - \frac{p^2}{4}}{500} + \frac{1,465 - d}{2} \frac{n + a}{a} + (q + w) \frac{2n + a}{a} + z + x_{a>0} - 0,030 - 0,065k \quad (614)$$

with  $x_a = \frac{1}{750} \left( an + n^2 - \frac{p^2}{4} - (120 - 20k) \right)$

$k$  and  $z$  = (see table 4)

TABLE 4:

GA GAUGE

if  $3,25 < h < 3,88$  m,  $k = \frac{h - 3,25}{0,63}$

if  $h \geq 3,88$  m,  $k = 1$

GB GAUGE

if  $3,25 < h < 4,11$  m  $k = \frac{h - 3,25}{0,86}$

if  $h \geq 4,11$  m,  $k = 1$

**▼B**

$$z = \left[ \frac{s}{30} + \tan \left( \eta_0 + \arctan \frac{(J - 0,005) > 0}{b_G} \right) (1 + s) - 1^\circ \right]_{>0} (h - h_c)^{>0} + \left[ \frac{s}{10} (h - h_c) - (0,04 - 0,01k)(h - 0,05) \right]_{>0}$$

**C.4.2.4.2. GC kinematic gauge**

The formulae to be applied are those associated with the G1 profile, irrespective of the value of h.

**C.5. GAUGES REQUIRING BI- OR MULTILATERAL AGREEMENTS**

The Infrastructure Managers of the different countries are free to conclude bi- or multilateral agreements between themselves in order to permit the running over the whole or part of their respective lines, of vehicles other than those built to the G1, GA, GB or GC profiles.

In order for such agreements to be made, it is sufficient to define a kinematic reference profile and associated rules.

**C.5.1. G2 gauge****C.5.1.1. Reference profile of G2 static gauge**

Certain Railways <sup>(1)</sup> authorise trains to run on their lines with loads fitting the reference profile shown below, for which the rules defined for static gauge G1 apply.

<sup>(1)</sup> Permitted by: HSH, GySEV, BHEV, PKP, BDZ, CFR, CD, ZSR, MAV, JZ, CH, TCDD, DB, ÖBB, CFL, NS, DSB, CFS, BV and IRR, except in the following stations:  
 JZ: Divaca, Sezana, Hrpelje-Kozina, Koper, Kilovce, Ilirska, Bistrica, Sapljane, Jurdani, Opatija-Matulji, Rijeka,  
 MAV: Budapest-Deli pu.-Budapest.Kelenföld

**▼B**

Fig. C22

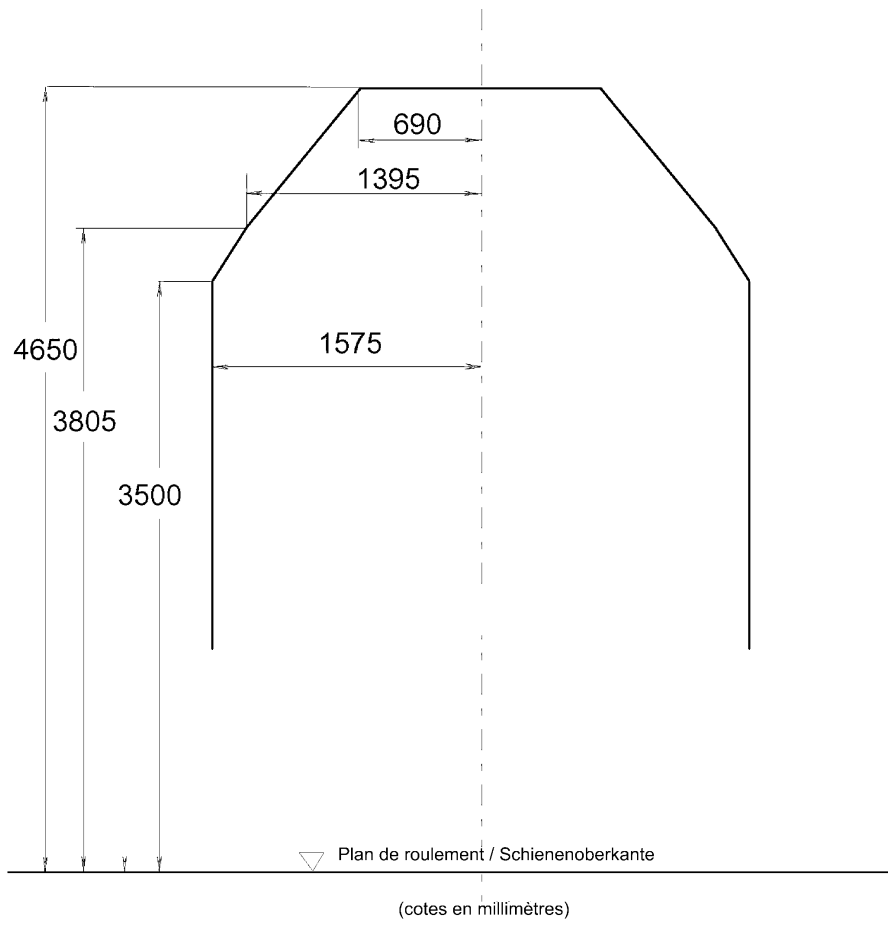

The Rules for the G1 static gauge should be applied.

**▼B**C.5.1.2. *Reference profile of G2 kinematic gauge*

The following kinematic reference profile shall be considered equivalent for the purpose of applying the standards pertaining to kinematic profiles.

Fig. C23

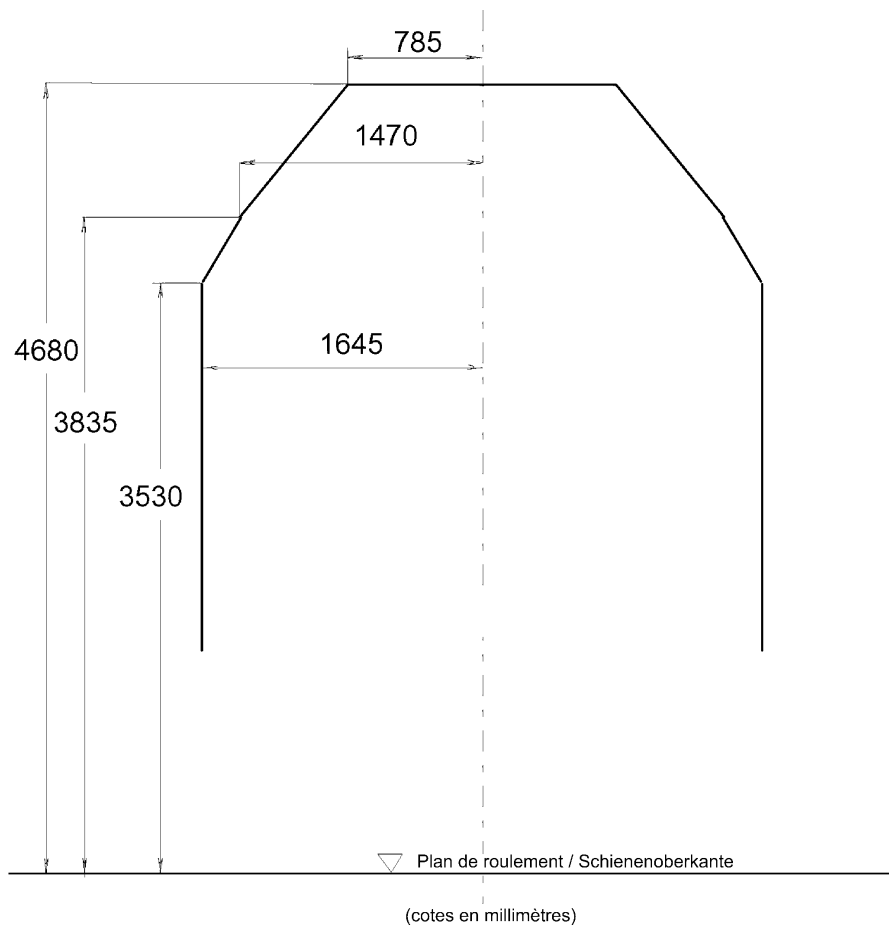
C.5.2. **GB1 and GB2 gauges**C.5.2.1. *General*

Gauges GB1 and GB2 were produced on the basis of certain combined transport requirements that emerged beginning in 1989.

Use of gauges GB1 and GB2 is subject to bi- or multilateral agreements being made between Infrastructure Managers.



**▼ B**

C.5.2.2. GB1 and GB2 static reference profiles (loading gauges)

GB1 static reference profile

Fig. C24

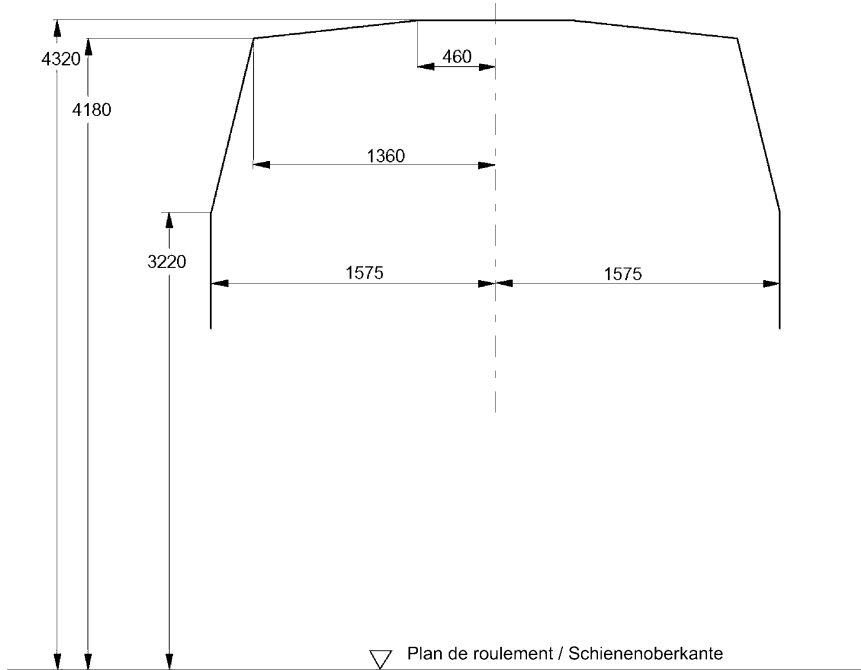

Note: Up to a height of 3 220 mm, the reference profile of the GB1 gauge is identical to that of the G1 gauge.

GB2 static reference profile

Fig. C25

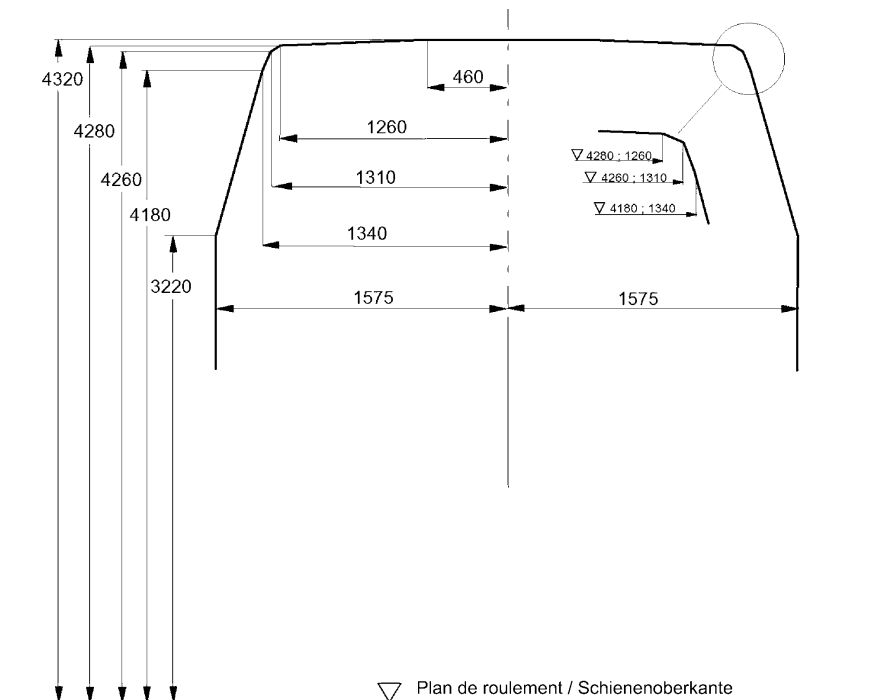

Note: Up to a height of 3 220 mm, the reference profile of the GB2 gauge is identical to that of the G1 gauge.

**▼B**C.5.2.3. *Rules for GB1 and GB2 static reference profiles*

The rules to be applied are those for the GB gauge, except for the coefficient  $k$  given in Table 1, the value of which is to be applied is given in the table below:

GB1 and GB2 GAUGE

$$\text{if } 3,22 < h < 4,18 \text{ m, } k = \frac{h - 3,22}{0,96}$$

if  $h \geq 4,18$  m,  $k = 1$

C.5.2.4. *GB1 and GB2 kinematic reference profiles*

GB1 kinematic reference profile

Fig. C26

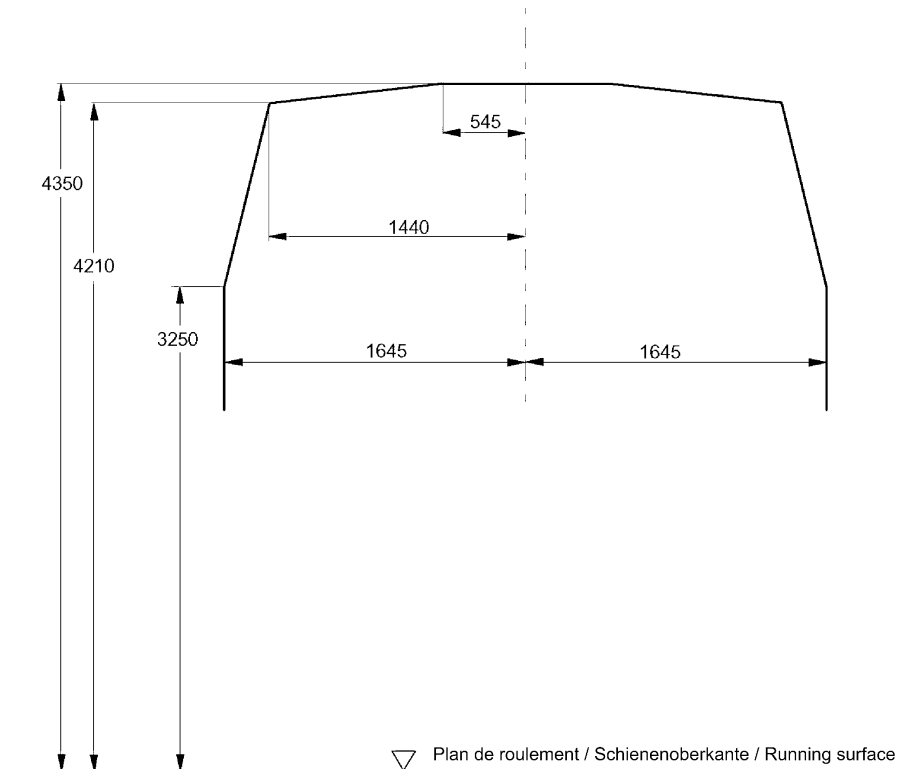

Note: Up to a height of 3 220 mm, the reference profile of the GB1 gauge is identical to that of the G1 gauge.

GB2 kinematic reference profile

▼B

Fig. C27

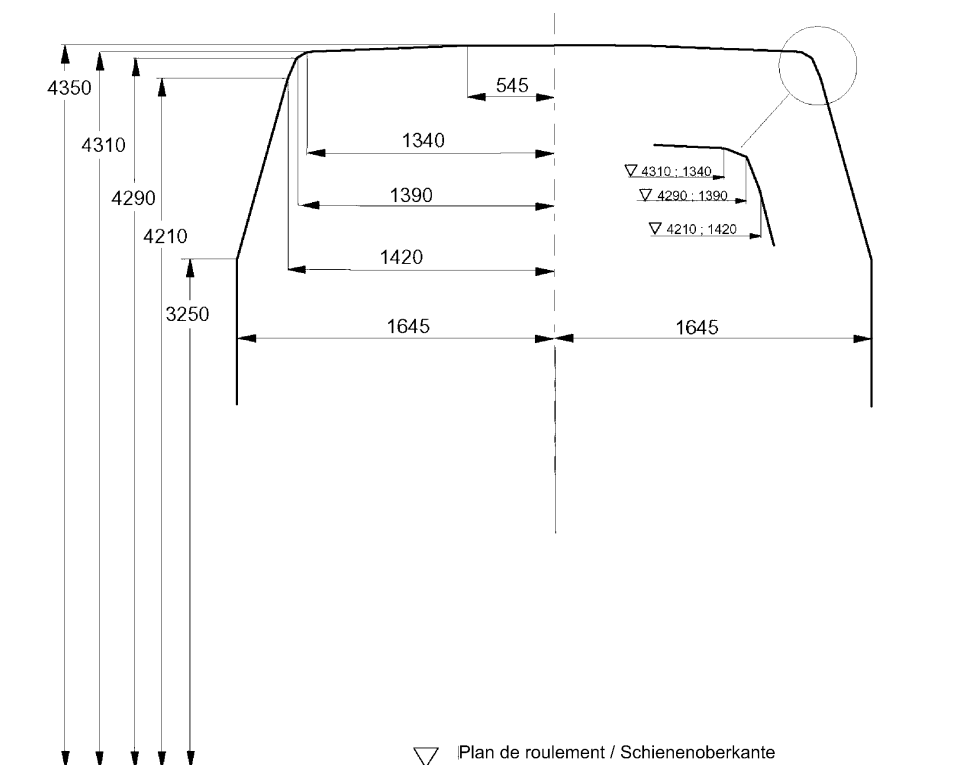

Note: Up to a height of 3 220 mm, the reference profile of the GB2 gauge is identical to that of the G1 gauge.

#### C.5.2.5. Rules for GB1 and GB2 kinematic reference profiles

The rules applicable are those for the GB gauge, except for the coefficient  $k$  given in Tables 2, 3 and 4, the value of which is to be applied is given in the table below:

GB1 and GB2 GAUGE

$$\text{if } 3,25 < h < 4,21 \text{ m, } k = \frac{h - 3,25}{0,96}$$

$$\text{if } h \geq 4,21 \text{ m, } k = 1$$

#### C.5.3. Gauge 3.3

##### C.5.3.1. General

Kinematic gauge 3.3 can be used for services running on the French network (Réseau Ferré National — RFN).

This gauge affords additional space towards the top compared with the G1 gauge. It is applicable to vehicles (for example, double-decker coaches) that run only on lines with gauge 3.3 clearances.

Gauge 3.3 concerns only the top part of the reference profile, above 3,25 m, the bottom part being common to the G1 gauge. As any other gauge, it is associated with a reference profile and associated rules.

▼ **B**C.5.3.2. *Reference profile of 3.3 kinematic gauge*

Fig. C28

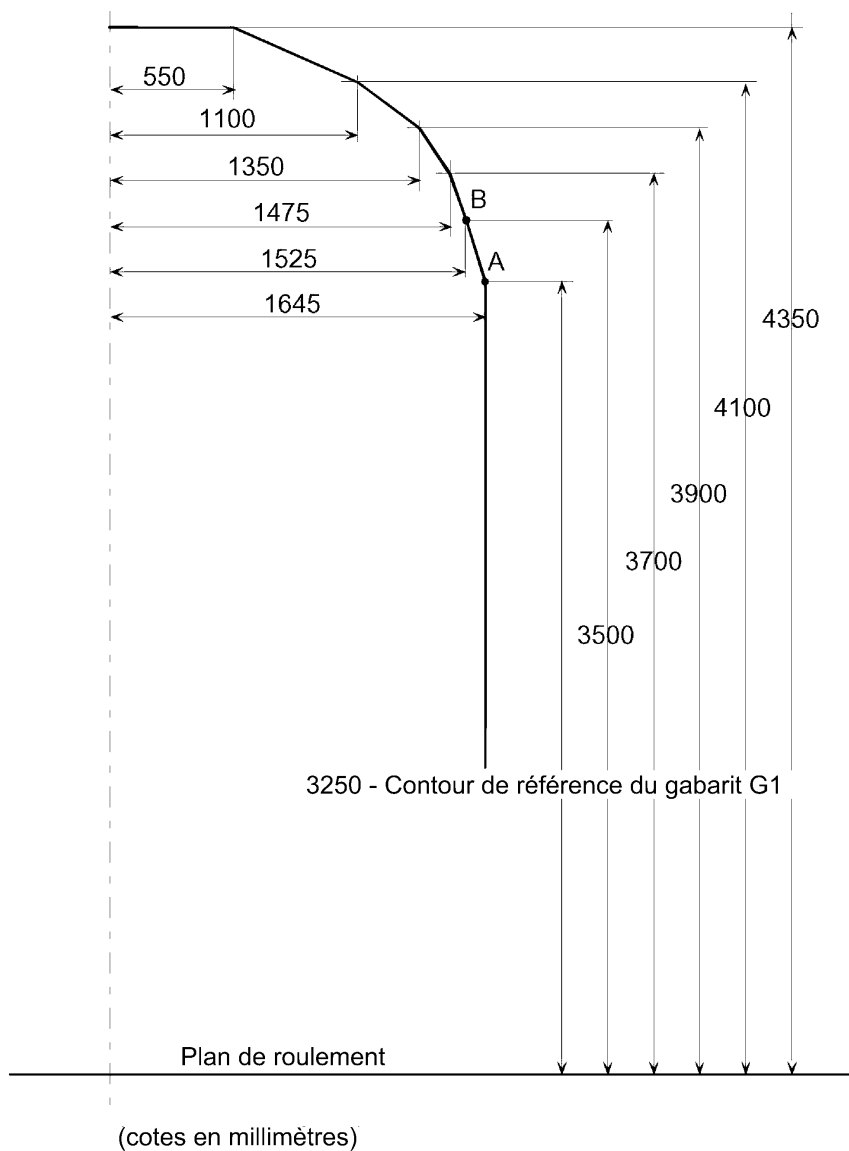
C.5.3.3. *Rules for the reference profile to determine the maximum construction gauge*

The rules for the reference profile of the 3.3 gauge are identical to those for the G1 gauge, except for the following specific details:

- Permitted projections  $S_0$  (S)
- Quasi-static displacements  $z$ .

C.5.3.3.1. *Permitted projections  $S_0$  (S)*

- For the parts located higher than 3,500 m from the running surface, the value  $S_0$  of the projection to be taken into account as a function of the curve to calculate the reductions  $E_i$  and  $E_a$  is  $\frac{37,5}{R}$  irrespective of the type of vehicle.
- Thus, the effective projections  $S$  must not exceed the following  $S_0$  values:
  - 0,15 m on 250 m radius curves
  - 0,15 m on 150 m radius curves.

**▼ B**

Moreover, on straight (tangent) track,  $S_0$  is set equal to 0,015 m.

- For the parts located higher than 3,250 m lower than 3,500 m above the running surface, that is the parts between levels A and B of the reference profile, there are no rules for fixing the value of  $S_0$  of the maximum projection. The determination the maximum construction gauge between these two levels is done by joining the point of the maximum construction gauge corresponding to Level A, found by calculating the reductions from the projections according to the rules for the G1 gauge, to the point of the maximum construction gauge corresponding to Level B, found by calculating the reductions from the above-stated projections.
- For the parts located less than 3,250 m above the running surface, the general rule for the G1 gauge should be applied.

#### C.5.3.3.2. Quasi-static displacements $z$

For suspended components, located at a height  $h$ , the value of  $z$  is given by the formula:

$$Z = \left[ \frac{S}{30} + \tan[\eta_0 - 1^\circ]_{>0} \right] |h - h_C| + \left[ \frac{S}{10} |h - h_C| - 0,03[h - 0,5]_{>0} \right]_{>0}$$

#### C.5.3.4. Reduction formulae

Reduction formulae applicable to:

- tractive vehicles (locomotives, power cars)      paragraph C.5.3.4.1
- multiple units      paragraph C.5.3.4.2
- coaches      paragraph C.5.3.4.3

#### C.5.3.4.1. Reduction formulae applicable to tractive units (dimensions in metres)

**Tractive units for which the play  $w$  is independent of the track position radius or varies linearly with the track curvature**

**Internal reductions  $E_i$**  (where  $n = n_i$ )

Sections **between** the end axles of traction vehicles not mounted on bogies or between the bogie pivots.

when  $an - n^2 + \frac{P^2}{4} - 500(W_\infty - W_{i(250)}) \leq 67,5$ , the position on straight track is preponderant:

$$E_i = \frac{1,465 - d}{2} + q + W_\infty + z - 0,015 \quad (101)$$

when  $an - n^2 + \frac{P^2}{4} - 500(W_\infty - W_{i(250)}) > 67,5$ , the position on curved track is preponderant:

$$E_i = \frac{an - n^2 + \frac{P^2}{4}}{500} + \frac{1,465 - d}{2} + q + i_{(250)} + Z + [x_i]_{>0} - 0,150 \quad (102)$$

$$\text{with } x_i = \frac{1}{750} \left( an - n^2 + \frac{P^2}{4} - 75 \right) + W_{i(150)} - W_{i(250)} \quad (103)$$

**External reductions  $E_a$**  (where  $n = n_a$ )

Sections **beyond** the end axles of vehicles not mounted on bogies or the bogie pivots of bogied tractive vehicles.

when  $an + n^2 - \frac{P^2}{4} - 500 \left[ (W_\infty - W_{i(250)}) \frac{n}{a} + (W_\infty - W_{a(250)}) \frac{n+a}{a} \right] \leq 67,5$ ,

the position on straight track is preponderant:

$$E_a = \left( \frac{1,465 - d}{2} + q + W_\infty \right) \frac{2n + a}{a} + z - 0,015 \quad (106)$$

**▼ B**

$$\text{when } an + n_2 - \frac{p^2}{4} - 500 \left[ (W_\infty - W_{i(250)}) \frac{n}{a} + (W_\infty - W_{a(250)}) \frac{n+a}{a} \right] > 67,5,$$

the position on curved track is preponderant:

$$E_a = \frac{an + n_2 - \frac{p^2}{4}}{500} + \left( \frac{1,465-d}{2} + q \right) \frac{2n+a}{a} + W_{i(250)} \frac{n}{a} + W_{a(250)} \frac{n+a}{a} + z + [x_a]_{>0} - 0,150 \quad (107)$$

$$\text{mit } x_a = \frac{1}{750} \left( an + n^2 - \frac{p^2}{4} - 75 \right) + (W_{i(150)} - W_{i(250)}) \frac{n}{a} + (W_{a(150)} - W_{a(250)}) \frac{n+a}{a} \quad (108)$$

**Tractive vehicles for which the play w varies non-linearly with the track curvature (exceptional case)**

For each section of the tractive vehicle, the reduction to be taken is the greatest of those resulting from the application of the above-given formulae, in which the value of R to be used is that which gives the highest value for the part between square brackets, and the formula (101) or (106).

**Internal reductions E<sub>i</sub>** (with n = n<sub>i</sub>)

When  $\infty > R \geq 250$

$$E_i = \left[ \frac{an - n^2 + \frac{p^2}{4} - 67,5}{2R} + w_{i(R)} \right] + \frac{1,465-d}{2} + q + z - 0,015 \quad (104)$$

When  $250 > R \geq 150$

$$E_i = \left[ \frac{an - n^2 + \frac{p^2}{4} - 75}{2R} + w_{i(R)} \right] + \frac{1,465-d}{2} + q + z \quad (105)$$

In practice, formulae (105) and (110) have no effect, since the variation in play w, resulting from the variable stops taking effect, begins only when  $R > 250$  m.

When  $\infty > R \geq 250$

$$E_a = \left[ \frac{an + n^2 - \frac{p^2}{4} - 67,5}{2R} + w_{i(R)} \frac{n}{a} + w_{a(R)} \frac{n+a}{a} \right] + \left( \frac{1,465-d}{2} + q \right) \frac{2n+a}{a} + z - 0,015$$

When  $250 > R \geq 150$

$$E_a = \left[ \frac{an + n^2 + \frac{p^2}{4} - 75}{2R} + w_{i(R)} \frac{n}{a} + w_{a(R)} \frac{n+a}{a} \right] + \left( \frac{1,465-d}{2} + q \right) \frac{2n+a}{a} + z$$

**External reductions E<sub>a</sub>** (where n = n<sub>a</sub>)

When  $\infty > R \geq 250$

$$E_a = \left[ \frac{an + n^2 - \frac{p^2}{4} - 67,5}{2R} + w_{i(R)} \frac{n}{a} + w_{a(R)} \frac{n+a}{a} \right] + \left( \frac{1,465-d}{2} + q \right) \frac{2n+a}{a} + z - 0,015 \quad (109)$$

**▼ B**

When  $250 > R \geq 150$

$$E_a = \left[ \frac{an + n^2 + \frac{P^2}{4} - 75}{2R} + W^{i(R)} \frac{n}{a} + W_{a(R)} \frac{n+a}{a} \right] + \left( \frac{1,465-d}{2} + q \right) \frac{2n+a}{a} + z \quad (110)$$

C.5.3.4.2. Reduction formulae applicable to multiple units (dimensions in metres)\*

For multiple units having a motor bogie and a trailer bogie (see the table for Gauge G1):

**Internal reductions  $E_i$  <sup>(1)</sup>**

Sections **between** bogie pivots

$$E_i = \frac{1,465-d}{2} + q + W_\infty \frac{a-n_\mu}{a} + W'_\infty \frac{n_\mu}{a} + z - 0,015 \quad (101a)$$

$$E_i = \frac{an_\mu - n_\mu^2 + \frac{P^2}{4} \cdot \frac{a-n_\mu}{a} + \frac{P^2}{4} \cdot \frac{n_\mu}{a}}{500} + \frac{1,465-d}{2} \cdot \frac{a-n_\mu}{a} + q + W_{i(250)} \frac{a-n_\mu}{a} + W'_{i(250)} \frac{n_\mu}{a} +$$

$$z + [x_i]_{>0} - 0,150$$

with

$$x_i = \frac{1}{750} \left[ an_\mu - n_\mu^2 + \frac{P^2}{4} \cdot \frac{a-n_\mu}{a} + \frac{P^2}{4} \cdot \frac{n_\mu}{a} - 75 \right] + \left( W_{i(150)} - W_{i(250)} \right) \frac{a-n_\mu}{a} +$$

$$\left( W'_{i(150)} - W'_{i(250)} \right) \frac{n_\mu}{a}$$

**External reductions  $E_a$  <sup>(2)</sup> motor bogie end** (at the front in the running direction)

Sections **beyond** the bogie pivots (where  $n = na$ )

$$E_a = \left[ \frac{1,465-d}{2} + q \right] \frac{2n+a}{a} + W_\infty \frac{n+a}{a} + W'_\infty \frac{n}{a} + z - 0,015 \quad (106a)$$

$$E_a = \frac{an + n^2 - \frac{P^2}{4} \cdot \frac{n+a}{a} + \frac{P^2}{4} \cdot \frac{n}{a}}{500} + \frac{1,465-d}{2} \cdot \frac{n+a}{a} + q \frac{2n+a}{a} + W'_{i(250)} \frac{n}{a} +$$

$$W_{a(250)} \frac{n+a}{a} + z + [x_a]_{>0} - 0,150$$

with

$$x_a = \frac{1}{750} \left[ an + n^2 - \frac{P^2}{4} \cdot \frac{n+a}{a} + \frac{P^2}{4} \cdot \frac{n}{a} - 75 \right] + \left( W'_{i(150)} - W'_{i(250)} \right) \frac{n}{a} + \left( W_{a(150)} - W_{a(250)} \right) \frac{n+a}{a} \quad (108a)$$

(1), (2) The reduction to apply for a given value of  $n$  is the greatest one resulting from the formulae:

— (101 a) or (102 a) and (103 a);

— (106 a) or (107 a) and (108 a).

**External reductions  $E_a$  <sup>(1)</sup> trailer bogie end** (at the front in the running direction)

Sections **beyond** the bogie pivots (where  $n = na$ )

$$E_a = \left[ \frac{1,465-d}{2} + q \right] \frac{2n+a}{a} + w_\infty \frac{n}{a} + w'_\infty \frac{n+a}{a} + z - 0,015 \quad (106b)$$

**▼ B**

$$E_a = \frac{an + n^2 + \frac{p^2}{4} \cdot \frac{n}{a} - \frac{p^2}{4} \cdot \frac{n+a}{a}}{500} + \left( \frac{1,465-d}{2} + q \right) \frac{2n+a}{a} + w_{i(250)} \frac{n}{a} + \quad (107b)$$

$$w'_{a(250)} \frac{n+a}{a} + z + [x_a]_{>0} - 0,150$$

$$x_a = \frac{1}{750} \left[ an + n^2 + \frac{p^2}{4} \cdot \frac{n}{a} - \frac{p^2}{4} \cdot \frac{n+a}{a} - 75 \right] + \left( w_{i(150)} - w_{i(250)} \right) \frac{n}{a} + \left( w'_{a(150)} - w'_{a(250)} \right) \frac{n+a}{a} \quad (108b)$$

- (1) The reduction to apply for a given value of n is the greatest one resulting from the formulae:

(106 b) or (107 b) and (108 b).

**C.5.3.4.3. Reduction formulae applicable to coaches and other passenger vehicles (dimensions in metres)**

For bogie coaches, except the bogies themselves and their associated parts.

*Coaches for which the play w is independent of the track position radius or varies linearly with the track curvature.*

**Internal reductions E<sub>i</sub>**

Sections **between** bogie pivots (where n = ni)

$$\text{when } an - n^2 + \frac{p^2}{4} - 500(w_\infty - w_{i(250)}) \leq 250(1,465 - d) + 67,5$$

the position on straight track is preponderant:

$$E_a = \frac{1,465-d}{2} + q + w_\infty + z - 0,015 \quad (201)$$

$$\text{when } an - n^2 + \frac{p^2}{4} - 500(w_\infty - w_{i(250)}) > 250(1,465 - d) + 67,5$$

the position on curved track is preponderant:

$$E_i = \frac{an - n^2 + \frac{p^2}{4}}{500} + q + w_{i(250)} + z + [x_i]_{>0} - 0,150 \quad (202)$$

$$\text{with } x_i = \frac{1}{750} \left( an - n^2 + \frac{p^2}{4} - 75 \right) + w_{i(150)} - w_{i(250)} \quad (203)$$

**External reductions E<sub>a</sub>**

Sections **beyond** bogie pivots (where n = na)

$$\text{When } an + n^2 - \frac{p^2}{4} - 500 \left[ (w_\infty - w_{i(250)}) \frac{n}{a} + (w_\infty - w_{a(250)}) \frac{n+a}{a} \right] \leq 250(1,465 - d) \frac{n}{a} + 67,5$$

the position on straight track is preponderant:

$$E_a = \left( \frac{1,465-d}{2} + q + w_\infty \right) \frac{2n+a}{a} + z - 0,015 \quad (206)$$

$$\text{When } an + n^2 - \frac{p^2}{4} - 500 \left[ (w_\infty - w_{i(250)}) \frac{n}{a} + (w_\infty - w_{a(250)}) \frac{n+a}{a} \right] > 250(1,465 - d) \frac{n}{a} + 67,5$$

the position on curved track is preponderant:

$$E_a = \frac{an + n^2 - \frac{p^2}{4}}{500} + \frac{1,465-d}{2} \cdot \frac{n+a}{a} + q \frac{2n+a}{a} + w_{i(250)} \frac{n}{a} + w_{a(250)} \frac{n+a}{a} + z + \quad (207)$$

$$[x_a]_{>0} - 0,150$$



**▼ B**

$$\text{with } x_a = \frac{1}{750} \left( an + n^2 - \frac{p^2}{4} - 75 \right) + \left( w_{i(150)} - w_{i(250)} \right) \frac{n}{a} + \left( w_{a(150)} - w_{a(250)} \right) \frac{n+a}{a} \quad (208)$$

*Coaches for which the play w varies non-linearly with the track curvature.*

For each section of the coach, the reduction to be taken is the greatest of those resulting from the application of the above-given formulae, in which the value of R to be used is that which gives the highest value for the part between square brackets, and the formula (201) or (206).

**Internal reductions Ei (where n = ni)**

When  $\infty > R \geq 150$

$$E_i = \left[ \frac{an - n^2 + \frac{p^2}{4} - 75}{2R} + w_{i(R)} \right] + q + z \quad (204)$$

**External reductions Ea (where n = na)**

When  $\infty > R \geq 250$

$$E_a = \left[ \frac{an + n^2 - \frac{p^2}{4} - 67,5}{2R} + W_{i(R)} \frac{n}{a} + W_{a(R)} \frac{n+a}{a} \right] + \frac{1,465-d}{2} \cdot \frac{n+a}{a} + q \frac{2n+a}{a} + z - 0,015$$

When  $250 > R \geq 150$

$$E_a = \left[ \frac{an + n^2 - \frac{p^2}{4} - 75}{2R} + W_{i(R)} \frac{n}{a} + W_{a(R)} \frac{n+a}{a} \right] + \frac{1,465-d}{2} \cdot \frac{n+a}{a} + q \frac{2n+a}{a} + z$$

**C.5.4. Gauge GB-M6****C.5.4.1. General**

The GB-M6 kinematic gauge can be used in services running on the Belgian (SNCB) network.

The GB-M6 kinematic gauge is based on the same principles as the G1 gauge, it is adapted to the SNCB infrastructure and its reduction formulae are likewise adapted as concerns the verification radii and the projections permitted in curves.

The permitted projections are more generous than those for the G1 gauge and therefore make it possible to run wider vehicles.

Concerning the pantograph, in addition to the UIC 505-1 regulations allowing vehicles equipped with 1 950 mm-wide pantographs to run, the SNCB infrastructure also accommodates 1 760 mm-wide pantographs fitted on more flexible vehicles with characteristics as follows:  $s \leq 0,4$  and  $(q + w) \leq 0,065$  m.

The bogies as well as their ancillary components fitted to vehicles built to this gauge strictly follow the rules for the G1 gauge.

Suspended parts located at a level, or which might descend to a level, less than 100 mm above the running surface due to vertical displacements are calculated in accordance with the G1 rules.

When, due to vertical movements, a point located near the 1 170 mm level might rise above or drop below this level, it is necessary to consider the minimum permitted width, by using either the formulae governing the parts above 1 170 mm, or the formulae governing the parts below or at the 1 170 mm level.

The choice between the reduction formulae for tractive units or for hauled units is made in the same way as for the G1 gauge, based on the coefficient of adhesion at start-up.

▼ B

C.5.4.2. Reference profile of the GB-M6 kinematic gauge

Fig. C29

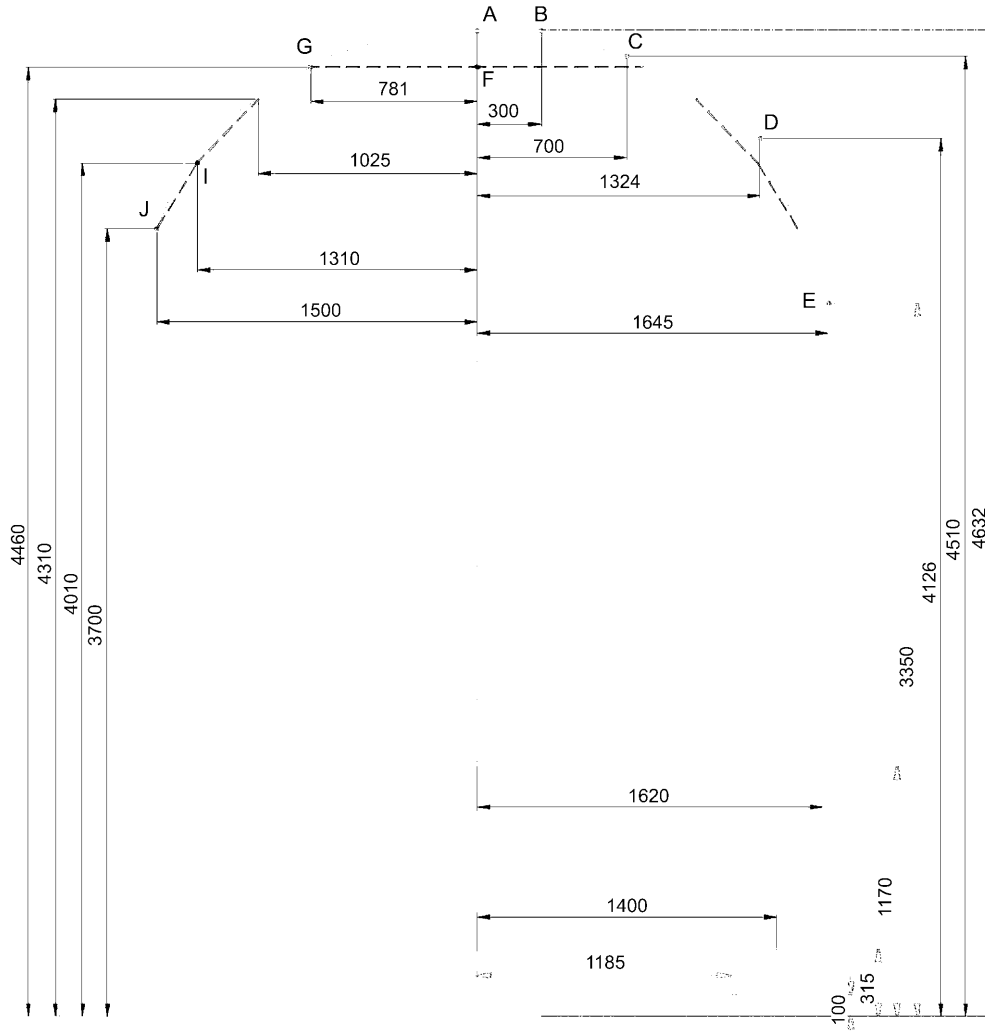

C.5.4.3. Reduction formulae

C.5.4.3.1. Tractive vehicles

a) Reduction formulae for  $h > 1\,170$  mm.

Sections **between** bogie pivots

$$\text{When } \frac{n(a-n) + \frac{p^2}{4}}{800} - (w_\infty - w_{i(400)}) \leq 0,015$$

$$E_i = \frac{1,465 - d}{2} + q + w_\infty + z - 0,015$$

$$\text{When } \frac{n(a-n) + \frac{p^2}{4}}{800} - (w_\infty - w_{i(400)}) > 0,015$$

**▼ B**

$$E_i = \frac{n(a-n) + \frac{p^2}{4}}{800} + w_{i(400)} + \frac{1,465-d}{2} + q + z + [x_i + (y_i)_{>0}]_{>0} - 0,030$$

$$\text{with } x_i = \frac{6}{10} \left[ \frac{n(a-n) + \frac{p^2}{4}}{800} \right] - 0,042 - (w_{i(400)} - w_{i(250)})$$

$$\text{with } y_i = \frac{16}{15} \left[ \frac{n(a-n) + \frac{p^2}{4}}{800} \right] - 0,108 - (w_{i(250)} - w_{i(150)})$$

Sections **beyond** bogie pivots

$$\text{When } \frac{n(a+n) - \frac{p^2}{4}}{800} - \left[ (w_\infty - w_{i(400)}) \frac{n}{a} + (w_\infty - w_{a(400)}) \frac{n+a}{a} \right] \leq 0,015$$

$$E_a = \left( \frac{1,465-d}{2} + q + w_\infty \right) \frac{2n+a}{a} + z - 0,015$$

$$\text{When } \frac{n(a+n) - \frac{p^2}{4}}{800} - \left[ (w_\infty - w_{i(400)}) \frac{n}{a} + (w_\infty - w_{a(400)}) \frac{n+a}{a} \right] > 0,015$$

$$E_a = \frac{n(a+n) - \frac{p^2}{4}}{800} + (q + w_{i(400)}) \frac{n}{a} + (q + w_{a(400)}) \frac{n+a}{a} + \left( \frac{1,465-d}{2} \right) \frac{2n+a}{a} + z + [x_a + (y_a)_{>0}]_{>0} - 0,030$$

$$\text{with } x_a = \frac{6}{10} \left[ \frac{n(a+n) - \frac{p^2}{4}}{800} \right] - 0,042 - \left[ (w_{i(400)} - w_{i(250)}) \frac{n}{a} + (w_{a(400)} - w_{a(250)}) \frac{n+a}{a} \right]$$

$$\text{with } y_a = \frac{16}{15} \left[ \frac{n(a+n) - \frac{p^2}{4}}{800} \right] - 0,108 - \left[ (w_{i(250)} - w_{i(150)}) \frac{n}{a} + (w_{a(250)} - w_{a(150)}) \frac{n+a}{a} \right]$$

c) Reduction formulae for heights  $100 < h \leq 1\,170$  mm.

Sections **between** bogie pivots

$$\text{When } \frac{n(a-n) + \frac{P^2}{4}}{2000} - (W_\infty - W_{i(1000)}) \leq 0,005$$

$$E_i = \frac{1,465-d}{2} + q + W_\infty + z - 0,015$$

$$\text{When } \frac{n(a-n) + \frac{P^2}{4}}{2000} - (W_\infty - W_{i(1000)}) > 0,005$$

$$E_i = \frac{n(a-n) + \frac{P^2}{4}}{2000} + \frac{1,465-d}{2} + q + W_{i(1000)} + z + [x_i]_{>0} - 0,020$$

**▼ B**

$$\text{with } x_i = \frac{17}{3} \left[ \frac{n(a-n) + \frac{P^2}{4}}{2000} \right] - 0,150 - (W_{i(1000)} - W_{i(150)})$$

Sections **beyond** bogie pivots

$$\text{When } \frac{n(a+n) - \frac{P^2}{4}}{2000} - \left[ (W_\infty - W_{i(1000)}) \frac{n}{a} + (W_\infty - W_{a(1000)}) \frac{n+a}{a} \right] \leq 0,005$$

$$E_a = \left( \frac{1,465-d}{2} + q + W_\infty \right) \frac{2n+a}{a} + z - 0,015$$

$$\text{When: } \frac{n(a+n) - \frac{P^2}{4}}{2000} - \left[ (W_\infty - W_{i(1000)}) \frac{n}{a} + (W_\infty - W_{a(1000)}) \frac{n+a}{a} \right] > 0,005$$

$$E_a = \frac{n(a+n) - \frac{P^2}{4}}{2000} + \left( \frac{1,465-d}{2} \right) \frac{2n+a}{a} + (q + W_{i(1000)}) \frac{n}{a} + (q + W_{a(1000)}) \frac{n+a}{a} +$$

$$z + [x_a]_{>0} - 0,020$$

$$\text{with } x_a = \frac{17}{3} \left[ \frac{n(a+n) - \frac{P^2}{4}}{2000} \right] - 0,150 - \left[ (W_{i(1000)} - W_{i(150)}) \frac{n}{a} + (W_{a(1000)} - W_{a(150)}) \frac{n+a}{a} \right]$$

#### C.5.4.3.2. Hauled vehicles

a) Reduction formulae for height  $h > 1\,170$  mm.

Sections **between** bogie pivots

$$\text{When } \frac{n(a-n) + \frac{p^2}{4}}{800} - (w_\infty - w_{i(400)}) \leq \frac{1,465-d}{2}$$

$$E_i = \frac{1,465-d}{2} + q + w_\infty + z - 0,015$$

$$\text{When } \frac{n(a-n) + \frac{p^2}{4}}{800} - (w_\infty - w_{i(400)}) > \frac{1,465-d}{2}$$

$$E_i = \frac{n(a-n) + \frac{p^2}{4}}{800} + q + w_{i(400)} + z + [x_i + (y_i)_{>0}]_{>0} - 0,015$$

$$\text{with } x_i = \frac{6}{10} \left[ \frac{n(a-n) + \frac{p^2}{4}}{800} \right] - 0,042 - (w_{i(400)} - w_{i(250)})$$

$$\text{with } y_i = \frac{16}{15} \left[ \frac{n(a-n) + \frac{p^2}{4}}{800} \right] - 0,108 - (w_{i(250)} - w_{i(150)})$$

Sections **beyond** bogie pivots

$$\text{When } \frac{n(a+n) - \frac{p^2}{4}}{800} - \left[ (w_\infty - w_{i(400)}) \frac{n}{a} + (w_\infty - w_{a(400)}) \frac{n+a}{a} \right] \leq \left( \frac{1,465-d}{2} \right) \frac{n}{a} + 0,015$$

**▼ B**

$$E_a = \left( \frac{1,465 - d}{2} + q + w_\infty \right) \frac{2n + a}{a} + z - 0,015$$

$$\text{When } \frac{n(a+n) - \frac{p^2}{4}}{800} - \left[ (w_\infty - w_{i(400)}) \frac{n}{a} + (w_\infty - w_{a(400)}) \frac{n+a}{a} \right] > \left( \frac{1,465 - d}{2} \right) \frac{n}{a} + 0,015$$

$$E_a = \frac{n(a+n) - \frac{p^2}{4}}{800} + (q + w_{i(400)}) \frac{n}{a} + (q + w_{a(400)}) \frac{n+a}{a} + \left( \frac{1,465 - d}{2} \right) \frac{n+a}{a} + z + [x_a + (y_a)_{>0}]_{>0} - 0,030$$

$$\text{with } x_a = \frac{6}{10} \left( \frac{n(a+n) - \frac{p^2}{4}}{800} \right) - 0,042 - \left[ (w_{i(400)} - w_{i(250)}) \frac{n}{a} + (w_{a(400)} - w_{a(250)}) \frac{n+a}{a} \right]$$

$$\text{with } y_a = \frac{16}{15} \left( \frac{n(a+n) - \frac{p^2}{4}}{800} \right) - 0,108 - \left[ (w_{i(250)} - w_{i(150)}) \frac{n}{a} + (w_{a(250)} - w_{a(150)}) \frac{n+a}{a} \right]$$

**b) Reduction formulae for heights 100 < h ≤ 1 170 mm.**Sections **between** bogie pivots

$$\text{When } \frac{n(a-n) + \frac{p^2}{4}}{2000} - (w_\infty - w_{i(1000)}) \leq \frac{1,465 - d}{2} - 0,010$$

$$E_i = \frac{1,465 - d}{2} + q + w_\infty + z - 0,015$$

$$\text{When } \frac{n(a-n) + \frac{p^2}{4}}{2000} - (w_\infty - w_{i(1000)}) > \frac{1,465 - d}{2} - 0,010$$

$$E_i = \frac{n(a-n) + \frac{p^2}{4}}{2000} + q + w_{i(1000)} + z + [x_i]_{>0} - 0,005$$

$$\text{with: } x_i = \frac{17}{3} \left( \frac{n(a-n) + \frac{p^2}{4}}{2000} \right) - 0,150 - (w_{i(1000)} - w_{i(150)})$$

Sections **beyond** bogie pivots

$$\text{When } \frac{n(a+n) - \frac{p^2}{4}}{2000} - \left[ (w_\infty - w_{i(1000)}) \frac{n}{a} + (w_\infty - w_{a(1000)}) \frac{n+a}{a} \right] \leq \left( \frac{1,465 - d}{2} \right) \frac{n}{a} + 0,005$$

$$E_a = \left( \frac{1,465 - d}{2} + q + w_\infty \right) \frac{2n + a}{a} + z - 0,015$$

$$\text{When } \frac{n(a+n) - \frac{p^2}{4}}{2000} - \left[ (w_\infty - w_{i(1000)}) \frac{n}{a} + (w_\infty - w_{a(1000)}) \frac{n+a}{a} \right] > \left( \frac{1,465 - d}{2} \right) \frac{n}{a} + 0,005$$

**▼ B**

$$E_a = \frac{n(a+n) - \frac{P^2}{4}}{2000} + \left( \frac{1,465-d}{2} \right) \frac{n+a}{a} + (q + W_{i(1000)}) \frac{n}{a} + (q + W_{a(1000)}) \frac{n+a}{a} + z +$$

$$[x_a]_{>0} - 0,020$$

with

$$x_a = \frac{17}{3} \left( \frac{n(a+n) - \frac{P^2}{4}}{2000} \right) - 0,050 - \left[ (W_{i(1000)} - W_{i(150)}) \frac{n}{a} + (W_{a(1000)} - W_{a(150)}) \frac{n+a}{a} \right]$$

## C.6. APPENDIX 1

### C.6.1. Rolling Stock Loading Gauge

#### C.6.1.1. Conditions concerning doors, steps and footboards

##### 1. Carriage doors

- a) In opened position, carriage doors whose bottom-most part is at least 1 050 mm above the rail-top, when the vehicle is in the lowest permissible position for the buffers, may project beyond the vehicle's reduced clearance gauge by at most 200 mm.

On vehicles built after 1.1.1986, the carriage doors must meet this requirement even during door opening.

This requirement does not apply to hinged doors fitted to coaches prior to 1.1.1980.

- b) At shunting speeds up to about 30 km/h, lateral play generally does not exceed 0,02 m.

For bodyside doors located beyond the bogie pivots and whose bottom edges are located less than 1 050 mm above the rail-top, the necessary reduction of the gauge, in the lowest permissible, 980 mm buffer position, can be reduced

— during opening and

— in opened position

by a maximum of  $\frac{(w_a - 0,02)(n+a)}{a}$

This applies only if  $w_a > 0,02$  m

It shall be permitted to use doors that meet the requirements of both a) and b) above. In that case, the requirements under a) must be met also during door opening.

##### 2. Steps and footboards

When the bottom step is retractable, the necessary reduction of the loading gauge for running with the step down may be cut back at most by the value:

$$w_i \frac{n}{a} + w_a \frac{n+a}{a}$$

## C.7. APPENDIX 2

### C.7.1. Rolling Stock Loading Gauge

#### C.7.1.1. Compression of the suspensions for areas outside the support polygon B, C and D

1. For all vehicles, and wagons in particular, it may be necessary to take account of additional vertical movements  $f_z$  due to inclination of the vehicle body (roll, pitching) following, for example, an off-centre load or deflation of a pneumatic suspension.

The following simplified formulae can be used for these additional compressions:

**▼ B**

- Lateral: zones concerned B and C  
Compression in phase on 2 bogies and a single rail.

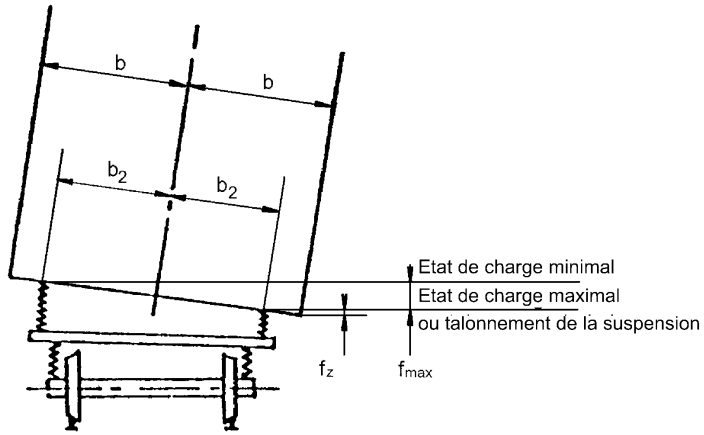

$$\frac{f_{max}}{2b_2} = \frac{f_z}{b - b_2} \qquad f_z = \frac{f_{max}(b - b_2)}{2b_2}$$

- Longitudinal: zones concerned, C and D  
Compression on single bogie or axle.

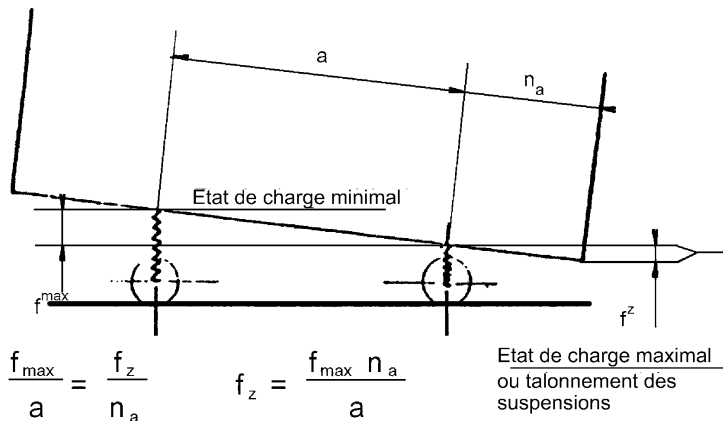

$$\frac{f_{max}}{a} = \frac{f_z}{n_a} \qquad f_z = \frac{f_{max} n_a}{a}$$

- Deflection of a primary suspension spring and a secondary suspension spring or deflated pneumatic suspension  
(calculation principle zone C).

**▼ B**

Deflection (in an initial approach).

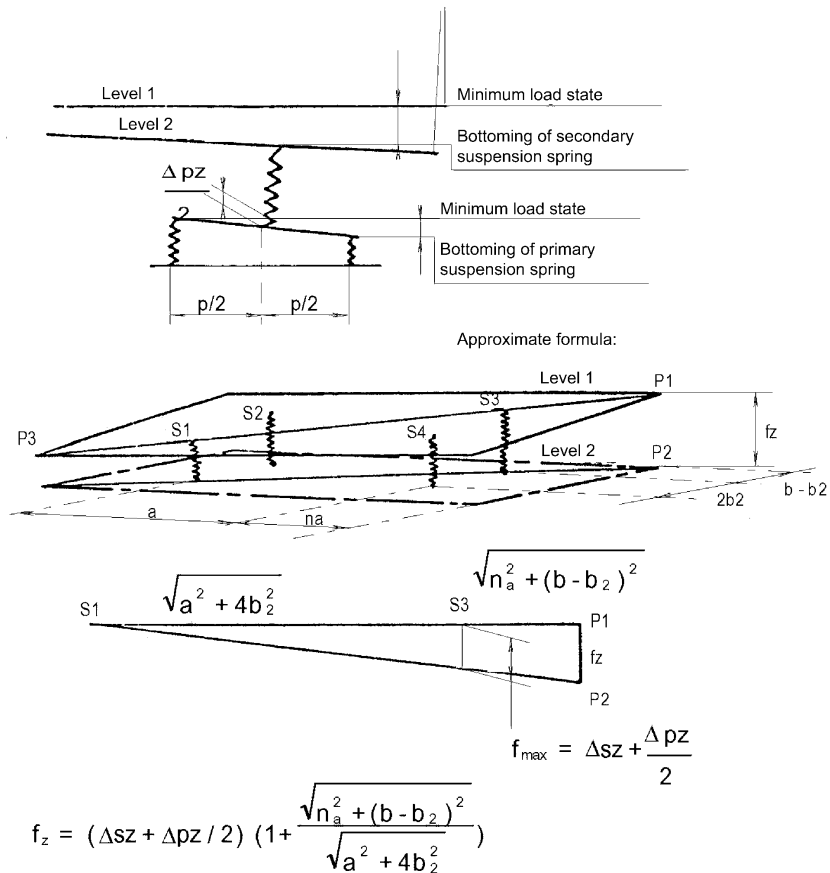

Legend:

Niveau 1: Level 1

Etat de charge minimal: Minimum load state

Talonnement du ressort de suspension primaire/secondaire: Bottoming of primary/secondary suspension spring

Formule approchée: Approximate formula

## C.8. APPENDIX 3 ROLLING STOCK LOADING GAUGE

### C.8.1. Calculation of the loading gauge of tilting vehicles

#### C.8.1.1. General

The acceptance into international service of rolling stock fitted with tilting body systems shall be subject to bilateral or multilateral agreements between the railways concerned.

#### C.8.1.2. Scope

This Appendix deals with the method of calculating the loading gauge of tilting body vehicles, hereinafter designated by the abbreviation **TBV**.

Paragraphs 2, 3 and 4 deal with the technical analysis of the calculation of the loading gauge of TBVs.

Paragraph 5 comments on the conditions of tilting and the speed of TBVs.



**▼B****C.8.1.3. *Field of application***

A TBV is defined as a vehicle in which the body can perform a rolling movement relative to the running gear when the vehicle goes round a curve, with the object of compensating for the centrifugal acceleration.

The appearance and the introduction into international service of trainsets made up of vehicles fitted with tilting body systems required certain modifications to be made to the rules regarding the loading gauge calculations for conventional vehicles.

This Appendix deals with the calculation rules for TBVs to obtain the maximum loading gauge for vehicle construction.

**C.8.1.4. *Background***

The TBV concept began to be developed in the years 1970-80 in several European countries in order to run with higher speeds on existing lines without detriment to the comfort of the passengers.

The speed in curves of railway vehicles is restricted because of the lateral acceleration which acts on the passengers: this limit of uncompensated acceleration is of the order of 1 to 1,3 ms<sup>-2</sup>.

TBV units, in particular those fitted with active systems, can run with higher values of uncompensated acceleration (for example 1,82 ms<sup>-2</sup> for the FIAT ETR 450 train, equivalent to a cant deficiency of 278 mm) because the tilting of the body enables the values of the lateral acceleration felt by the passengers to be reduced.

**C.8.1.5. *Conditions related to safety***

The Builders of TBV units shall provide evidence that the vehicles meet the loading gauge under all the different cases of operation that are planned.

In addition to the calculation of the loading gauge, the Builder shall supply a report on the criteria adopted and on the devices on which safety depends, that is devices that must 'fail safe'.

Failure cases which might result in TBV units exceeding the reference profile shall be investigated by the Builder. Depending on the seriousness of their effects, special measures shall be taken by the Railways, that may concern railway operations, alarms, warnings to the driver, etc.

The Builder shall also guarantee that the tilting system is so designed that the units cannot run with values of uncompensated acceleration higher than the values allowed for conventional vehicles if the tilting system fails.

**C.8.1.6. *Symbols used***

The following additional symbols are used in this Appendix:

- IP = value of the cant deficiency considered for the TBV
- IC = value of the maximum cant deficiency permitted by the Permanent Way Department of the Railway <sup>(1)</sup> 1)
- E = value of the cant
- zP = quasi-static displacements determined according to the needs of the TBV units

**C.8.2. *Basic conditions to determine the loading gauge of TBV units***

For the calculation of the loading gauge of TBV units, all the running conditions shall be examined both with the tilting system active and inactive.

The worst cases shall be examined, in particular:

- SITUATION 1) case of a vehicle running in a curve with maximum cant deficiency (maximum body tilt);
- SITUATION 2) case of a vehicle stationary in a curve. When an active TBV is stopped on a curve its position does not differ from that of a conventional vehicle and, therefore, can be dealt with using the principles and formulae applicable to a conventional vehicle.

<sup>(1)</sup> The justification of the need to take account of this parameter, fixed by the Permanent Way Department of the Railways, in the rolling stock dimensional calculations is given in Section 3.2.2 of this Appendix.

▼ **B**

Note also that for certain types of passive TBV units, such as the TALGO, there is no quasi-static inclination  $z$  due to the flexibility, i.e.  $s = 0$ .

### C.8.2.1. *Types of body tilting systems*

In spite of the above, the different tilting system designs can be grouped according to the method of tilt of the bodies. This tilt can be obtained either with a natural or an equivalent tilting movement (passive tilt) when the centre of rotation of the body is above the position of the bodies' centre of gravity, as in the TALGO system, or by jacks which tilt the body depending on the radius of curvature and the speed (by an active tilting movement as in the FIAT system).

Let us examine the inclination of the body allowed by the different body tilting systems:

In the case of TBVs fitted with **ACTIVE** systems, the bodies are subjected to a quasi-static tilt caused by the uncompensated acceleration: This is not, however, the same as the body tilt imparted separately by the system. **Figure 1a** shows the principle of the inclination of a vehicle with an active tilt system.

*Fig. C30*

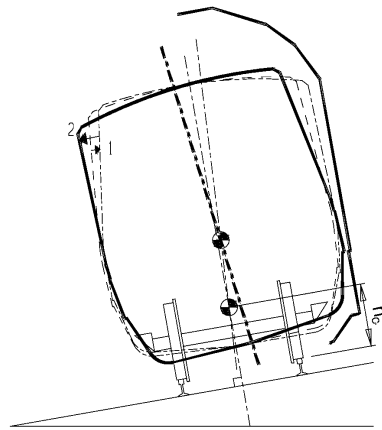

The actual movements can be broken down into a rotation due to the roll (movement 1) and a rotation superimposed on that by the active system (movement 2).

In the case of **PASSIVE** systems the body tilts naturally under the effect of the centrifugal force applied, which is proportional to the cant deficiency.

Figure 1b shows the principle of inclination of a vehicle with natural or passive tilt.

*Fig. C31*

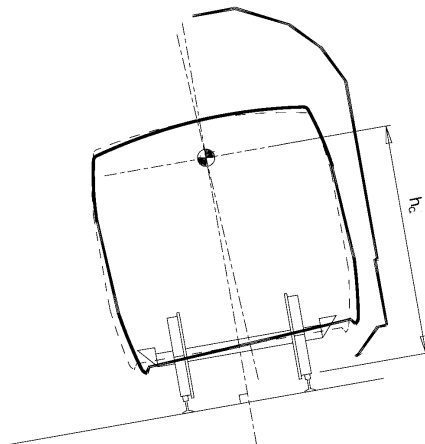

**▼ B****C.8.3. Analysis of the formulae****C.8.3.1. Basic formulae**

Depending on the different types of TBV to be investigated (coaches, power cars or multiple unit motor coaches) the corresponding formulae for the G1 gauge shall be used, to which shall be added all the modifications presented in this Appendix.

**C.8.3.2. Modifications to be made to the formulae for TBVs**

For TBVs the maximum tilt of the body corresponding to the maximum cant deficiency IP must be considered. Given this requirement, the following terms of the reduction formulae shall have to be reconsidered:

**a) Lateral plays:  $(1,465-d)/2$ , q and w <sup>(1)</sup>**

The sign of the lateral displacements, in general, should take account of the centrifugal effect.

The changes required are discussed in § 8.3.2.1.

**b) Quasi-static displacements 'z'**

The term z is valid provided that vehicles do not exceed, when running, the cant deficiency value IP = 200 mm.

As TBVs can exceed this value and, in general, because of the fact that they can run with values of cant deficiency IP greater than those specified by the Permanent Way Department (IC), the formula needs some modifications which are discussed in § 8.3.2.2.

**c) For certain types of TBV, especially the active ones, a further term to take account of the body tilt imparted by the system will need to be added to the formulae for calculating the reductions (see 8.3.2.3).****C.8.3.2.1. Expression for the values of the lateral plays when the body is tilted**

The condition of maximum body tilt occurs only when the vehicle runs round a curve with the maximum value of IP.

As the vehicle is submitted to a very high centrifugal force towards the outside of the curve, the terms of the lateral displacements shall be reconsidered.

— The play w shall be taken towards the outside of the curve.

— For the plays  $(1,465 - d)/2$  and q it is necessary to distinguish between bogie vehicles and vehicles with independent wheels.

Bogie vehicles, calculation of play on the inside of the curve:

On-line tests have shown that for bogie vehicles, some axles run round the curve with the flange in contact with the outer rail, while others do not maintain this contact constantly. As a result and for safety reasons, the plays mentioned above shall be taken equal to zero.

Bogie vehicles, calculation of play on the outer side of the curve:

The plays  $(1,465 - d)/2$  and q shall be taken, likewise for reasons of safety, on the outside of the curve.

Vehicles with independent wheels:

The tests have confirmed that the plays  $(1,465 - d)/2$  and q occur towards the outside of the curve.

**C.8.3.2.2. Quasi-static displacement of a TBV**

To obtain the clearances to structures, the Permanent Way Department must add certain terms to the dimension of the reference profile. The quasi-static displacements of vehicles are calculated with the formula below:

$$\frac{0,4}{1,5} \cdot [E_{ouI} - 0,05]_{>0} \cdot (h-0,5)_{>0}$$

The maximum allowable value for E<sub>or</sub> I is 200 mm.

<sup>(1)</sup> For the TBV calculation this term must be measured at the height h<sub>c</sub> above the running surface of the rail. It can have different values for a same given vehicle, depending on configuration, according to the tilt technology and possible re-centring of the body.

## ▼ B

Each Infrastructure Manager fixes for its lines its own maximum value for  $I$ . The values generally used are between 90 and 180 mm.

Vehicles must not exceed this maximum value of  $I$  when running.

On the other hand, TBVs reach higher values. This means that their dimensions need to be checked with a different calculation for the quasi-static displacements.

Just as for conventional vehicles, the effect of a cant deficiency induces in TBV units a tilting of the body around a longitudinal axis, a rotation which is due to the flexibility of the suspension system. In the formulae, the quasi-static displacements corresponding to this rotation are taken into consideration in the term 'z'. Because TBVs can run with cant deficiencies of up to  $I_p$  it is necessary to revise the calculation of this term ( $zP$ ).

It is appropriate to introduce this new term  $zP$ , the formulation of which takes account of the total quasi-static tilt due to  $IP$ , in relation to that considered by the Permanent Way Department, IC (see paragraphs 3.2.2.1 and 3.2.2.2).

Moreover, for the active tilting systems, it is necessary to consider a supplementary term (see 3.2.3), because the tilting of the body to compensate for the centrifugal acceleration is independent of the tilt due to the roll.

### C.8.3.2.2.1. Expression of the quasi-static displacements $zP$ for the reductions on the inside of the curve

Under the effect of the lateral acceleration associated with  $IP$  values greater than 0, the body of the vehicle, because of the flexibility of the suspensions, tilts towards the outside of the curve when active tilting is used and towards the inside of the curve when passive tilting is used. The following figures show this type of displacement from the position  $I = 0$ . Due to the different modes of tilting, with the active system the displacements are largest at the upper part of the vehicle body, whereas with the passive system they are largest at the lower part of the vehicle body.

Fig. C32:

#### ACTIVE system

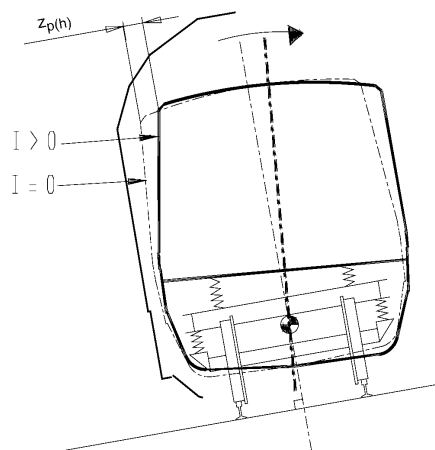

Note: The tilt imparted by the system is not represented here.

— Since the reference profile is considered from the standpoint of the inside of the curve, the points of the vehicle situated at a height  $h > h_c$  move away from the profile. The value of this displacement in the calculation will carry a minus sign.

The opposite is true for points situated at a height  $h < h_c$ .

▼B

Fig. C33:

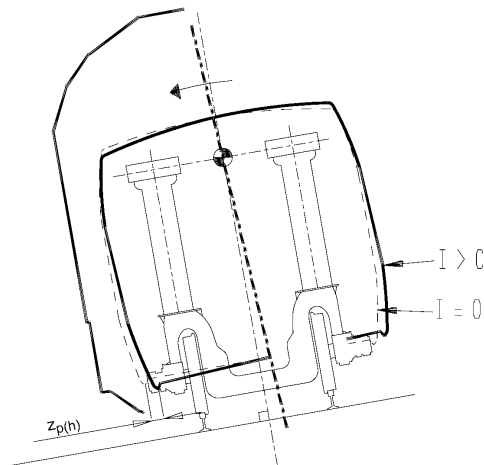
**PASSIVE system**

— Since the reference profile is considered from the standpoint of the inside of the curve, the points of the vehicle situated at a height  $h < h_c$  move away from the profile. The value of this displacement in the calculation will have a minus sign.

— The opposite is true for points situated at a height of  $h > h_c$ .

The displacements corresponding to different tilts shown in Figures 2a and 2b are indicated below.

**For a TBV unit with an active system** running on a curve with a cant deficiency IP the quasi-static displacements are:

$$Z_p = \frac{S}{1,5} \cdot I_p \cdot (h - h_c) \text{ with } \eta_0 < 1^\circ$$

**For a TBV unit with a passive system** subjected to a cant deficiency IP the quasi-static displacements are:

$$Z_p = \frac{S}{1,5} \cdot I_p \cdot (h - h_c) \text{ with } \eta_0 < 1^\circ$$

It is necessary to draw attention to the fact that the value of  $s$  is specific to the situation calculated and can, therefore, be influenced by the action of the body tilt system.

#### C.8.3.2.2.2. Expression of the quasi-static displacements $z_p$ , for the reductions on the outer side of the curve

Under the effect of the lateral acceleration (corresponding to values  $IP > 0$ ) the body of an active TBV unit tilts towards the outside of the curve because of the flexibility of the suspension system and towards the inside of the curve for a passive TBV unit.

Similarly to Figures 2a and 2b, the Figures 3a and 3b represent this type of displacement, from the position  $I = 0$ .

▼B

Fig. C34:

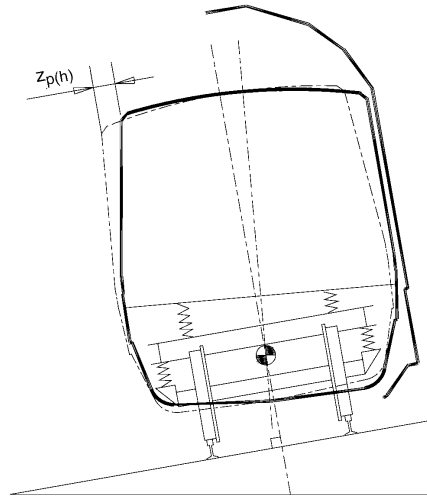
**ACTIVE system**

*Note:* The tilt imparted by the system is not represented here.

- Since the reference profile is considered from the standpoint of the outside of the curve, the points of the vehicle situated at a height  $h > h_c$  move closer to the profile. The value of this displacement in the calculation will have a plus sign.
- The opposite is true for the points situated at a height of  $h < h_c$ .

Fig. C35:

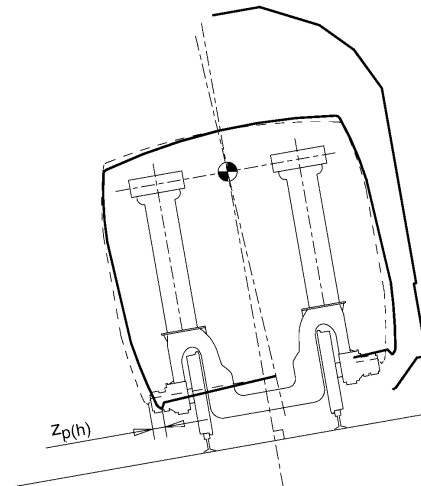
**PASSIVE system**

- Since the reference profile is considered from the standpoint of the outside of the curve, the points of the vehicle situated at a height  $h < h_c$  move closer to the profile. The value of this displacement in the calculation will have a plus sign.
- The opposite is true for the points situated at a height of  $h > h_c$ .

When the vehicles run in a curve they move closer to the reference profile (on the outer side) in proportion to the value of IP; if the condition  $IP > IC$ , is present, the distances considered by the Permanent Way Department for the positioning of obstacles will not be sufficient. Since the position of obstacles cannot be questioned, the reductions calculated for vehicles should, if necessary, be increased by a value corresponding to the difference between the quasi-static displacements due to IP and those taken into account by the Permanent Way Department or:

**▼ B**

Active system

$$z = \left[ \frac{s}{1,5} \cdot I_p \cdot (h - h_c) - \frac{0,4}{1,5} \cdot (I_c - 0,05) \cdot (h - 0,5) \right]_{>0}$$

Passive system

$$z = \left[ -\frac{s}{1,5} \cdot I_p (h - h_c) - \frac{0,4}{1,5} \cdot (I_c - 0,05) \cdot (h - 0,5) \right]_{>0}$$

It must be remembered that:

- the formulae apply where  $IP > IC$ ;
- it will be necessary to find in the application phase corresponding to a real case, the combination of the values for  $IP$  and  $IC$  which give a value of  $zP$  that maximises the reduction:
- the tilting system of the vehicle must ensure the following for the intermediate values of  $IP$  (marked  $IP'$ ), to which correspond the intermediate values of cant deficiency  $Ic'$ :

$$I_p' \leq \frac{I_p}{I_c} \cdot I_c'$$

Furthermore, the conditions given in 5.1 must be met.

#### C.8.3.2.3. ACTIVE systems: displacements due to body rotation

When an active-system TBV runs over a curve at a speed such that  $IP > 0$ , based on measurement of the value of certain parameters (speed, cant gradient, curve radius) the tilting system establishes the angle of body tilt  $\beta$ .

The angle  $\beta$  is independent of the tilt due to the flexibility of the suspensions.

Fig. C36

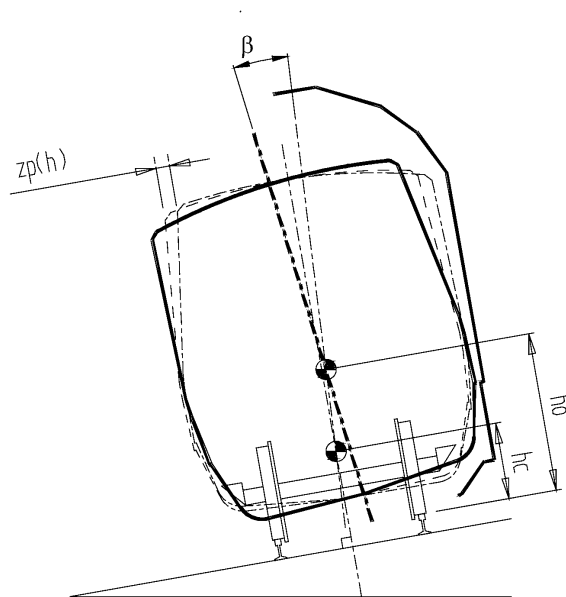

In Figure 4 the following values are represented:

- h<sub>0</sub>**: height of the centre of rotation of the body imposed by the system.
- β**: value of the angle of body tilt, relative to the system bearing plane; this angle imposed by the system is a function of the cant deficiency  $IP$ .

Since angle  $\beta$  can be as great as  $10^\circ$ , the vertical component of the displacement must not be overlooked and it shall be taken into account in the calculation for real cases.

If only the lateral displacements are considered, approximate values can be found by the following formula:

$$\tan \beta (h - h_0)$$

This term, in light of the direction of rotation imposed by the system,

**▼B**

- shall carry a positive sign in the calculations on the inside of the curve
- shall carry a minus sign in the calculations on the outside of the curve.

**C.8.4. Associated Rules**

- The formulae apply for  $IP > IC$ .
- The expression of the term  $zP$  shall be detailed and explained, case by case, when the formulae are applied to each type of system, bearing in mind the different stops, the roll centre, etc.
- It should be stressed that the parameters,  $s$ ,  $h_c$  and  $w$ , in agreement with the technical principles of the TBV unit, for any given vehicle have different values depending on the calculation cases involved.
- The maximum values of the reductions shall be calculated depending on the different values likely to be taken by  $IP$ ,  $IC$  (and by the angle  $\beta$  for active TBVs, see § 3.2.3). For this purpose the TBV Builder should bear in mind the most prominent places permitted on the bodies when running over different sections of line (straight track, transitions, curves) and the possible tolerances with respect to the effective position of the vehicle (due to the delay in system activation, inertia, friction, etc).
- The parts of the TBVs which are not connected to the body and, therefore, do not tilt, always remain subject to a value of uncompensated acceleration greater than that normally accepted. For these items (such as the bogies and sometimes the pantograph), a supplementary term taking account of the reduction shall be used when the tilting body is checked.

This term is of the form:  $\frac{S}{1,5} (Ip - Ic)(h - hc)$

Moreover, no account shall be taken of the term  $\tan \beta (h - h_0)$  for these parts (see § 3.2.3).

- This Appendix has been developed on the basis of information applicable to the TBV units in service today. Other hypotheses and modifications to the formulae may be added, in the future, after new types of TBV units have been developed.
- When the examination of all the cases which were thought to be critical has been completed, a comparison shall be made between the different permissible half-width dimensions and the smallest value at each of the heights  $h$  considered shall be selected.

**C.8.5. Comments****C.8.5.1. Condition for adjusting the inclination (TBV units with active system)**

For the formulae that have been given in this Appendix for the calculation of the loading gauge of TBV units to be valid it is necessary that the tilt system guarantees that the body is inclined in a way that is proportional to the variation of the cant deficiency.

For the passive systems this condition is obviously fulfilled as the tilt of the body is caused by the low cant.

For TBV units with an active tilt system on the other hand, the values that the system imposes on the bodies are fixed by the design or adjustment of the system.

These values shall meet the following conditions in order that the bodies do not exceed the specified profile:

- a) The intermediate values  $IP'$ ,  $IC'$  and  $E'$  between 0 and the maximum value of the respective sizes, shall meet, from a point of view of the regulation of the tilting system, the following condition:

$$\frac{I'_P}{I_P} = \frac{I'_C}{I_C} = \frac{E'}{E}$$



**▼ B**

b) Moreover in the case of checking on the outside of the curve, in view of the fact that the centrifugal force tilts the body towards the outside (quasi-static displacement  $z_P$ ), the following condition, regarding the value of  $\beta$  for the adjustment shall be observed:

$$\tan \beta (h - h_0) \geq z_p$$

In other words, the effect of the system must be greater than or equal to the quasi-static effect.

#### C.8.5.2. Condition concerning the speed of TBV units

For TBVs, it is permissible to calculate a maximum speed from the standpoint of the loading gauge than for other vehicles.

Reference should be made to the expression that relates the cant deficiency to the speed:

$$I_{PorC} = 0,01186 \cdot \frac{V_{PorC}^2}{R} - E$$

The speeds  $v_P$  and  $v_C$  are respectively the value taken by the TBV and the corresponding value allowed for the track, according to the ruling speed for the line.

$$\text{Thus: } V_P \leq \sqrt{\frac{I_P + E}{I_C + E}} \cdot V_C$$

From this formula, it is possible to deduce the maximum speed value that must not be exceeded by the TBV, using the following formula:

$$V_P \leq \sqrt{\frac{I_P + E}{I_C + E}} \cdot V_C$$

#### C.8.6. Appendix 4 Rolling Stock Loading Gauge

Use of existing infrastructure clearances by vehicles with predefined parameters

A bilateral agreement shall be required before applying this appendix.

Example:

On straight track in good maintenance condition with the usual defects in track geometry, the decisive criterion shall be the maximum distance between track centres; this equals the width of the reference profile plus margins for random movements of the vehicle due to defects in track geometry (D).

$$D = \sqrt{d_i^2 + d_a^2}$$

$$d_{i,a} = 1,2 \sqrt{\sum t_{i,a}^2}$$

$$t_{i|a=1}^{i=5}$$

$$t_{a|a=1}^{a=5}$$

$t_1$  = lateral movement of the track

$t_2$  = impact of a cant or cross-level defect of 0,015 m

$t_{3i, a}$  = oscillations towards the inside or towards the outside

$t_4$  and  $t_5$  = impact of load imbalance and of asymmetries

$$t_1 = 0,025$$

$$t_2 = 0,15 \frac{h}{1,5} + 0,015(h - h_C) \frac{S}{1,5}$$

$$t_{3,i} = 0,007(h - h_C) \frac{S}{1,5}$$

$$t_{3,a} = 0,039(h - h_C) \frac{S}{1,5}$$

$$t_4 = 0,05(h - h_C) \frac{S}{1,5}$$

**▼ B**

$$t_5 = 0,015(h - h_c) \frac{S}{1,5}$$

The following parameters shall be used to determine the margins (clearances) to be added to the G1 reference profile:

$$h = 3,25 \text{ m}$$

$$h_c = 0,5 \text{ m}$$

$$s = 0,4$$

The predefined parameters of the vehicle under examination can be used, for instance:

$$h = 1,8 \text{ m (height above the running surface of a certain body section)}$$

$$h_c = 0,7 \text{ m}$$

$$s = 0,24$$

Based on the above parameters, the following values can be obtained:

$$\text{— for profile G1} \quad D = 0,113 \text{ m}$$

$$\text{— for the vehicle with predefined parameters} \quad D' = 0,058 \text{ m}$$

The difference  $D - D' = 0,055 \text{ m}$  can be used as a basis for widening a vehicle with predefined parameters.

If the additional clearance covering random movements is not calculated as described, but a flat overall value is defined, and if this results in smaller dimensions, this should be taken into consideration for the calculation of  $D - D'$ .

Example: SNCF,  $V \leq 120 \text{ km/h}$ :  $D_{\text{SNCF}} = 0,05 + 0,03 = 0,08 \text{ m}$ .

The vehicle with predefined parameters could then be widened by  $0,022 \text{ m}$  at a height of  $1,8 \text{ m}$ .

▼ B

## ANNEX D

## VEHICLE TRACK INTERACTION AND GAUGING

## Static axle load, dynamic wheel load and linear load

## D.1 LOAD LIMITS FOR WAGONS ACCORDING TO THE CLASSIFICATION OF LINES.

## Diagram of wagons to be considered for determining the line category

a = distance between bogie axles

b = distance from first axle to the end of the nearest buffer

c = distance between the two inside axles

Category	Mass per axle	Mass per unit length						
A	P=16 t	p=5,0 t/m	1,50	1,80	6,20	1,80	1,50	12,80
B1	P=18 t	p=5,0 t/m	1,50	1,80	7,80	1,80	1,50	14,40
B2	P=18 t	p=6,4 t/m	1,50	1,80	4,65	1,80	1,50	11,25
C2	P=20 t	p=6,4 t/m	1,50	1,80	5,90	1,80	1,50	12,50
C3	P=20 t	p=7,2 t/m	1,50	1,80	4,50	1,80	1,50	11,10
C4	P=20 t	p=8,0 t/m	1,50	1,80	3,40	1,80	1,50	10,00
D2	P=22,5 t	p=6,4 t/m	1,50	1,80	7,45	1,80	1,50	14,05
D3	P=22,5 t	p=7,2 t/m	1,50	1,80	5,90	1,80	1,50	12,50
D4	P=22,5 t	p=8,0 t/m	1,50	1,80	4,65	1,80	1,50	11,25

Open for E, F and G lines and for categories 5 and 6

▼ **B**

## D.2 LOAD LIMITS FOR WAGONS ACCORDING TO THE CLASSIFICATION OF LINES.

**WAGONS WITH TWO 2-AXLE BOGIES**

Permissible maximum mass per  $P_r$  on the various line categories in relation to the dimensions a and b

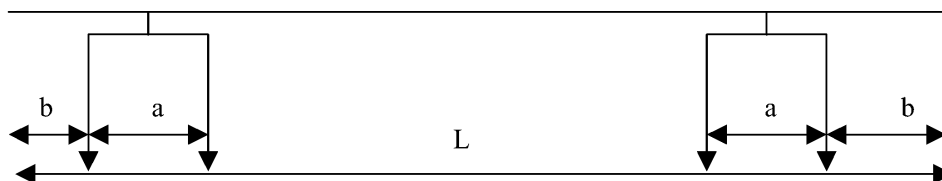

Values of the dimensions		Line categories				
A	b	D4 D3 D2	C4 C3 C2	B2 B1	A	
M	m	t	t	T	t	
1,80	1,50	22,5	20	18	16	
	1,40	21,5	19	17	15	
	1,30	20,5	18,5	16,5	15	
	1,20	20	18	16	14	
1,70	1,50	22	19,5	17,5	15,5	
	1,40	21	19	17	15	
	1,30	20	18	16	14	
	1,20	19,5	17,5	15,5	14	
1,60	1,50	21	19	17	15	
	1,40	20	18,5	16,5	14,5	
	1,30	19	17,5	15,5	14	
	1,20	18,5	17	15	13,5	
1,50	1,50	20	18,5	16,5	14,5	
	1,40	19,5	18	16	14	
	1,30	19	17,5	15,5	13,5	
	1,20	18	17	14,5	13	
1,40	1,50	19	17	15,5	13,5	
	1,40	18	17	15,5	13,5	
	1,30	18,5	16,5	15	13	
	1,20	17,5	15,5	14	12	
1,30	1,50	18,5	16,5	15	13	
	1,40	18,5	16,5	15	13	
	1,30	18	16,5	14,5	12,5	
	1,20	17	15,5	13,5	11,5	

**IMPORTANT NOTE:** The masse per axle shown in the above table are only valid if the wagon length L between buffers is such that the mass per unit length p falls within the line category under consideration. Otherwise the permissible mass per axle load is lower and shall be equal to  $\frac{pL}{4}$ .

Open for E, F and G lines and for categories 5 and 6

▼ **B**

## D.3 LOAD LIMITS FOR WAGONS ACCORDING TO THE CLASSIFICATION OF LINES.

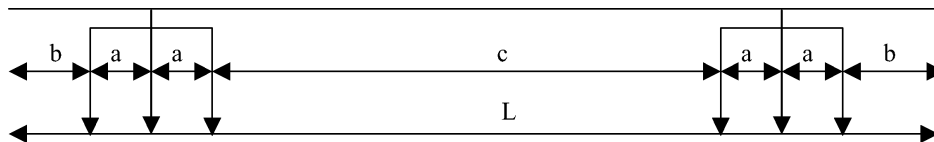
**WAGONS WITH TWO 3-AXLE BOGIES**Permissible maximum mass per  $P_r$  on the various line categories in relation to the dimensions a and b

Values of dimensions		Line categories								
A	b	D 4	D 3	D 2	C 4	C 3	C 2	B 2	B 1	A
M	m	t	t	t	t	t	t	T	t	t
1,80	1,50	18	18	18	16,5	16,5	16,5	15	14,5	13
	1,40	18	18	17,5	16	16	16	14,5	14	12,5
	1,30	18	17,5	17	16	16	15,5	14,5	13,5	12
	1,20	18	17	16	16	16	15	14,5	13	12
1,70	1,50	17,5	17,5	17,5	16	16	16	14,5	14	12,5
	1,40	17,5	17,5	17	15,5	15,5	15,5	14	13,5	12
	1,30	17,5	17	16	15,5	15,5	15	14	13	12
	1,20	17,5	16,5	16	15,5	15,5	14,5	14	13	12
1,60	1,50	17	17	17	15,5	15,5	15,5	14	13,5	12
	1,40	17	17	16	15	15	15	13,5	13	12
	1,30	17	16,5	16	15	15	14,5	13,5	13	11,5
	1,20	17	16	15,5	15	15	14	13,5	12,5	11,5
1,50	1,50	16,5	16,5	16	15	15	15	13,5	13	12
	1,40	16,5	16,5	16	14,5	14,5	14,5	13	13	11,5
	1,30	16,5	16,5	15,5	14,5	14,5	14,5	13	12,5	11,5
	1,20	16,5	16	15,5	14,5	14,5	14	13	12,5	11,5
1,40	1,50	15,5	15,5	15,5	14	14	14	12,5	12,5	11,5
	1,40	15,5	15,5	15,5	14	14	14	12,5	12,5	11,5
	1,30	15,5	15,5	15,5	14	14	14	12,5	12,5	11,5
	1,20	15,5	15,5	15,5	14	14	14	12,5	12,5	11,5
1,30	1,50	15	15	15	13,5	13,5	13,5	12	12	11
	1,40	15	15	15	13,5	13,5	13,5	12	12	11
	1,30	15	15	15	13,5	13,5	13,5	12	12	11
	1,20	15	15	15	13,5	13,5	13,5	12	12	11

**IMPORTANT NOTE** : The masses per axle shown in the above table are only valid:

- 1) if the dimension  $c$  is  $> 2b$ . Otherwise the dimension  $b$  shall not be taken as the value of  $b$ , but the value  $\frac{c}{2}$  or the nearest value below shown in the table;
- 2) if the wagon length  $L$  between buffers is such that the mass per unit length  $p$  falls within the line category under consideration. Otherwise the permissible mass per axle is lower and shall be equal to  $\frac{pL}{6}$ .

Open for E, F and G lines and for categories 5 and 6

▼ **B**

## D.4 LOAD LIMITS FOR WAGONS ACCORDING TO THE CLASSIFICATION OF LINES.

<b>WAGONS WITH TWO 4-AXLE BOGIES</b>	
Permissible maximum mass per axle $P_r$ on the various line categories in relation to the dimensions a and b	

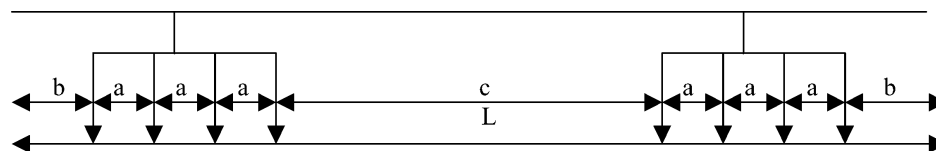

Values of dimensions		Line categories								
A	b	D 4	D 3	D 2	C 4	C 3	C 2	B 2	B 1	A
M	m	t	t	t	t	t	t	T	t	t
1,80	1,50	17,5	16,5	15,5	16	16	15	14,5	13	11,5
	1,40	17	16,5	15	16	15,5	14,5	13,5	12,5	11
	1,30	17	16	15	16	15	14	13,5	12	10,5
	1,20	16,5	15	14,5	16	15	13,5	13	11,5	10,5
1,70	1,50	17,5	16	15	15,5	15,5	14,5	14	12,5	11
	1,40	17	16	15	15,5	15	14	13,5	12	10,5
	1,30	16,5	15	14,5	15,5	14,5	13,5	13	11,5	10,5
	1,20	15,5	15	14	15,5	14,5	13,5	12,5	11	10
1,60	1,50	16,5	15,5	15	15	15	14	13,5	12	10,5
	1,40	16	15	14,5	15	14,5	13,5	13	11,5	10
	1,30	15,5	14,5	14	14,5	14	13	12,5	11	10
	1,20	15	14,5	14	14,5	14	13	12	11	10
1,50	1,50	16	15	14,5	14,5	14,5	13,5	13	11,5	10,5
	1,40	15,5	14,5	14	14,5	14	13	12,5	11	10
	1,30	15	14	13	14	13,5	12,5	12	10,5	9,5
	1,20	15	14	13	14	13	12,5	12	10,5	9,5
1,40	1,50	15	14,5	13	13	13	13	12	10,5	10
	1,40	15	14	13	13	13	12,5	12	10,5	10
	1,30	15	13,5	12,5	13	13	12	12	10	9,5
	1,20	14,5	13	12,5	13	12,5	11,5	11,5	10	9,5
1,30	1,50	14,5	14	13	12,5	12,5	12,5	11,5	10,5	9,5
	1,40	14,5	13,5	13	12,5	12,5	12	11,5	10,5	9,5
	1,30	14,5	13	12,5	12,5	12,5	11,5	11,5	10	9
	1,20	14	13	12,5	12,5	12	11,5	11	10	9

**IMPORTANT NOTE** : The masses per axle shown in the above table are only valid:

- 1) if the dimension  $c$  is  $> 2b$ . Otherwise the dimension  $b$  shall not be taken as the value of  $b$ , but the value  $\frac{c}{2}$  or the nearest value below shown in the table<sup>(1)</sup>;
- 2) if the wagon length  $L$  between buffers is such that the mass per unit length  $p$  falls within the line category under consideration. Otherwise the permissible mass per axle is lower and shall be equal to  $\frac{pL}{8}$ .

Open for E, F and G lines and for categories 5 and 6

<sup>(1)</sup> If  $\frac{c}{2} < 1,20$  m, a special study is required.

▼ **B**

## D.5 LOAD LIMITS FOR WAGONS ACCORDING TO THE CLASSIFICATION OF LINES.

**WAGONS WITH 3 OR 4 BOGIES, EACH WITH 2 AXLES**

Permissible maximum mass per axle  $P_r$  on the various line categories in relation to the dimensions a, b and c

## D.5.1 Wagons with three 2-axle bogies

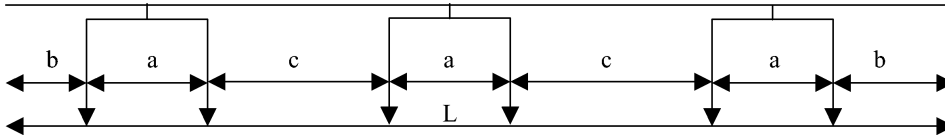

If  $c \geq 2b$ : the values given in D.2 shall be taken

If  $c < 2b$ : the values given in D.2 shall be taken and the dimension b shall not be taken as the value of b, but the value  $\frac{c}{2}$  or the nearest value below appearing in the table <sup>(1)</sup>.

## D.5.2 Wagons with four 2-axle bogies

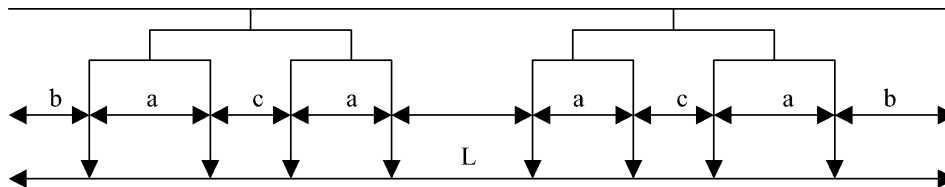

If  $2,40 \leq c < 2b$ : the values given in D.2 shall be taken and the dimension b shall not be taken as the value of b, but the  $\frac{c}{2}$  or the nearest value below appearing in D.2.

If  $c < 2,40$  m: the values given in D.4 shall be taken and the lesser of the dimensions a or c shall be taken as the value of a.

**IMPORTANT NOTE** : The masses per axle shown in the above table are only valid if the wagon length L between buffers is such that the mass per unit length p falls within the line category under consideration. Otherwise the permissible mass per axle is equal to:

$$\frac{pLc}{6} \text{ for wagons with three 2-axle bogies,}$$

$$\frac{pL}{8} \text{ for wagons with four 2-axle bogies.}$$

Open for E, F and G lines and for categories 5 and 6

<sup>(1)</sup> If  $\frac{c}{2} < 1,20$  m, a special study is required.



## D.6 LOAD LIMITS FOR WAGONS ACCORDING TO THE CLASSIFICATION OF LINES.

### LOAD LIMITS FOR TWO-AXLE WAGONS

The table below gives the results of the comparisons in relation to the length over buffers L for wagons in common use, i.e. for maximum axle loads of 22,5, 20, 18 and 16 t.

When however, as stated in this leaflet, extra restrictions are required because of specific characteristics of the wagon or the load or as a result of fast forwarding conditions, the stricter values should be applied instead of those shown in the table below.

#### Load limits for two-axle wagons

Wagon characteristics		Line categories				
L (m)	P (t)	A	B1	B2	C	D
L > 7,20	22,5	32-T	36-T		40-T	45-T
	20	32-T	36-T		40-T	
	18	32-T	36-T			
	16	32-T				

Open for E, F and G lines and for categories 5 and 6

Note: Requirements for wagons with length lower than 7.2 m are deleted because these wagons are not still bild.

## D.7 LOAD LIMITS FOR WAGONS ACCORDING TO THE CLASSIFICATION OF LINES.

### LOAD LIMITS FOR WAGONS WITH TWO 2-AXLE BOGIES

The table below gives the results of the comparisons in relation to the length over buffers L for wagons in common use, i.e. for maximum axle loads of 22,5, 20, 18 and 16 t.

When however, as stated in this leaflet, extra restrictions are required because of specific characteristics of the wagon or the load or as a result of fast forwarding conditions, the stricter values should be applied instead of those shown in the table below.

#### Load limits for wagons with two 2-axle bogies

Wagon characteristics		Line categories									
L	P	A	B1	B2	C2	C3	C4	D2	D3	D4	
L > 14,40	22,5	64-T	72-T		80-T			90-T			
	20	64-T	72-T		80-T						
	18	64-T	72-T								
	16	64-T									
14,06 < L < 14,40	22,5	64-T	5L-T	72-T	80-T			90-T			
	20	64-T	5L-T	72-T	80-T						
	18	64-T	5L-T	72-T							
	16	64-T									



## ▼B

Wagon characteristics		Line categories								
L	P	A	B1	B2	C2	C3	C4	D2	D3	D4
12,80 < L < 14,06	22,5	64-T	5L-T	72-T	80-T			6,4L-T	90-T	
	20	64-T	5L-T	72-T	80-T					
	18	64-T	5L-T	72-T						
	16	64-T								
12,50 < L < 12,80	22,5	5L-T	5L-T	72-T	80-T			6,4L-T	90-T	
	20	5L-T	5L-T	72-T	80-T					
	18	5L-T	5L-T	72-T						
	16	5L-T	5L-T	64-T						
11,25 < L < 12,50	22,5	5L-T	5L-T	72-T	6,4-L-T	80-T		6,4L-T	7,2-L-T	90-T
	20	5L-T	5L-T	72-T	6,4-L-T	80-T		6,4L-T	80-T	
	18	5L-T	5L-T	72-T						
	16	5L-T	5L-T	64-T						
11,10 < L < 11,25	22,5	5L-T	5L-T	6,4L-T		80-T		6,4L-T	7,2-L-T	8L-T
	20	5L-T	5L-T	6,4L-T		80-T		6,4L-T	80-T	
	18	5L-T	5L-T	6,4L-T		72-T		6,4L-T	72-T	
	16	5L-T	5L-T	64-T						

Wagon characteristics		Line categories								
L	P	A	B1	B2	C2	C3	C4	D2	D3	D4
10,00 < L < 11,10	22,5	5L-T	5L-T	6,4L-T		7,2L-T	80-T	6,4L-T	7,2L-T	8L-T
	20	5L-T	5L-T	6,4L-T		7,2L-T	80-T	6,4L-T	7,2L-T	80-T
	18	5L-T	5L-T	6,4L-T		72-T		6,4L-T	72-T	
	16	5L-T	5L-T	64-T						

*NOTE:* Bogie wagons with a length over buffers of less than 10 m do not exist in practice and are therefore not taken into account.

Open for E and F lines and for categories 5 and 6



## ANNEX E

**VEHICLE TRACK INTERACTION AND GAUGING**  
**Wheelset dimensions and tolerances for standard gauge**

Table E1

Designation	Wheel diameter (mm)	Minimum value (mm)	Maximum value (mm)
Distance between flange contact faces ( $S_R$ ) $S_R = A_R + S_d(\text{left wheel}) + S_d(\text{right wheel})$	$\geq 840$	1 410	1 426
	$< 840$ and $\geq 330$	1 415	1 426
Back to back distance ( $A_R$ )	$\geq 840$	1 357	1 363
	$< 840$ and $\geq 330$	1 359	1 363
Width of the rim ( $B_R$ )	$\geq 330$	133	140 <sup>(1)</sup>
Thickness of the flange ( $S_d$ )	$\geq 840$	22	33
	$< 840$ and $\geq 330$	27,5	33
Height of the flange ( $S_h$ )	$\geq 760$	28	36
	$< 760$ and $\geq 630$	30	36
	$< 630$ and $\geq 330$	32	36
Face of flange ( $q_R$ )	$\geq 330$	6.5	
Wheel tread defects, e.g. wheel flats, shelled treads, cracks, grooves, cavities etc	National rules apply until EN is published		

<sup>(1)</sup> Burr value included

The dimensions  $S_R$  and  $A_R$  are measured at the top surface of the rail, and shall be complied with for freight wagons in laden and tare conditions and for loose wheelsets. For specific vehicles smaller tolerances within the above limits may be specified by the vehicle supplier.

▼ B

Fig. E1 — Symbols

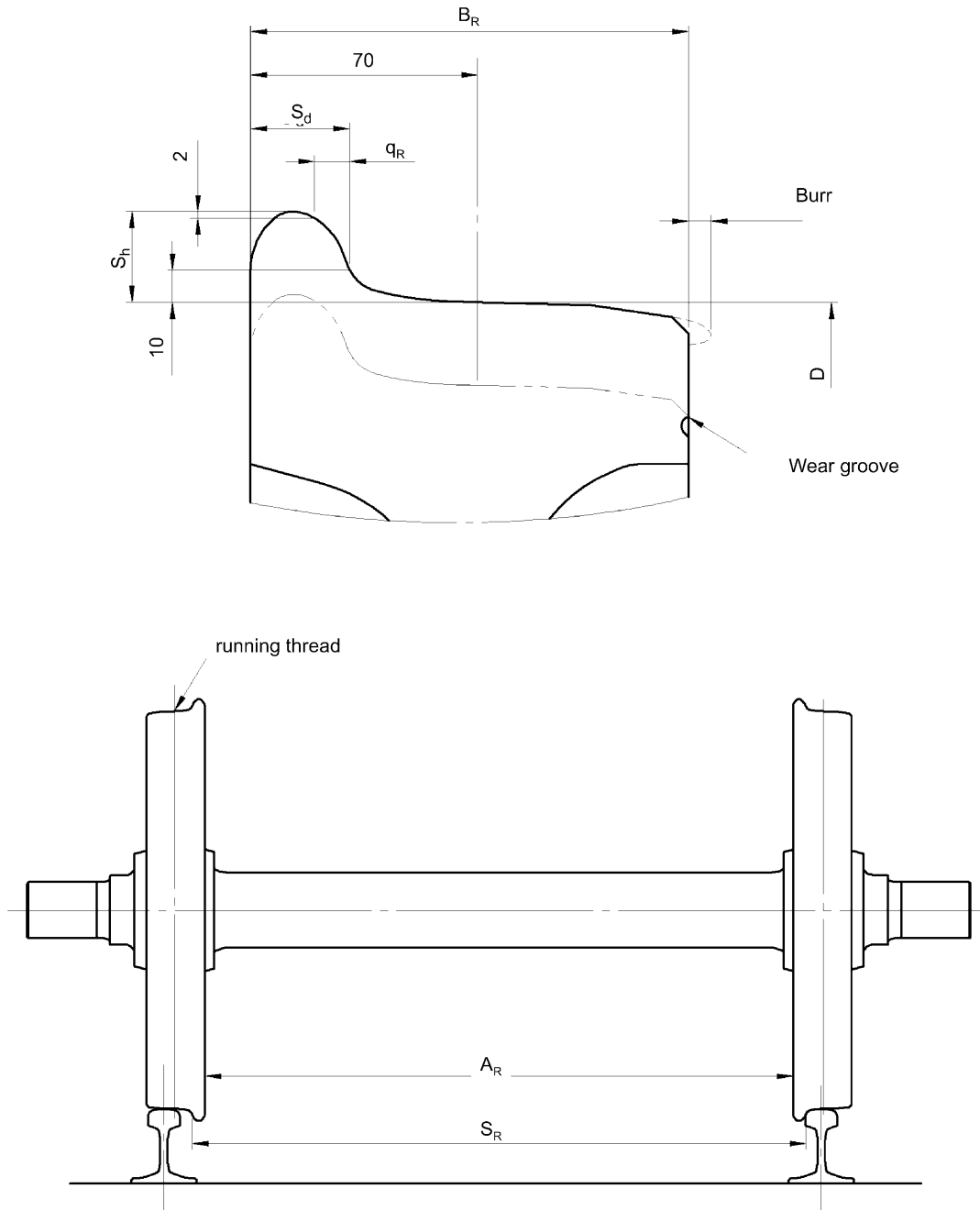

▼B

ANNEX F

COMMUNICATION

Vehicle capability to transmit information between ground and vehicle

Fig. F1

Tag position on wagon.

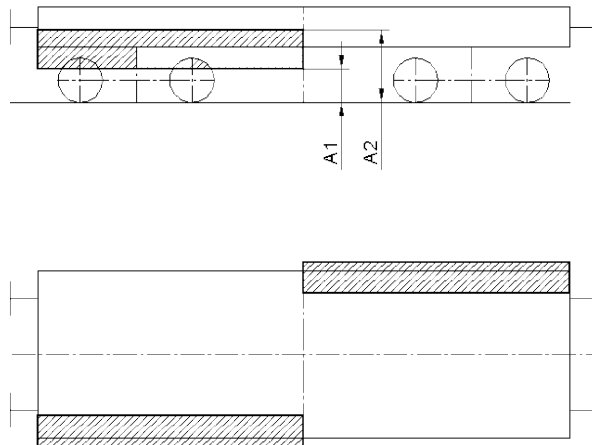

In the Fig. F1 (above), A1 and A2 are respectively the minimum and maximum height above rail for positioning the centres of the tags in all conditions of wagon loading and suspension movement:

- A1 = 500 mm
- A2 = 1100 mm

Fig. F2

Installation constraints for tag readers

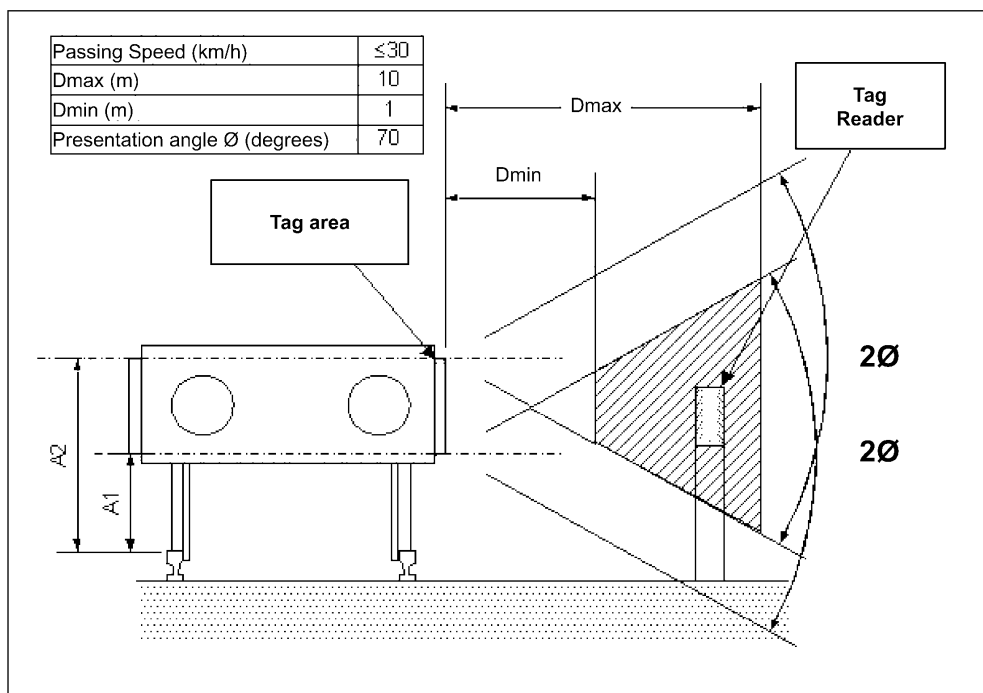

▼B

ANNEX G

ENVIRONMENTAL CONDITIONS

Humidity

Fig. G1

Absolute air humidity ( $\text{g/m}^3$ )

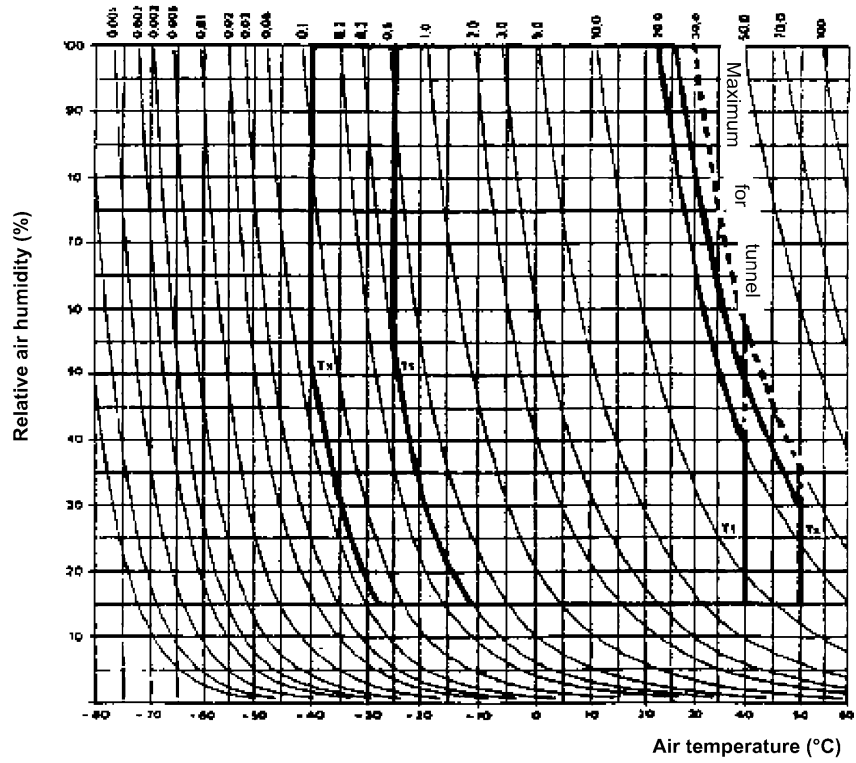

▼  
B

Fig G2

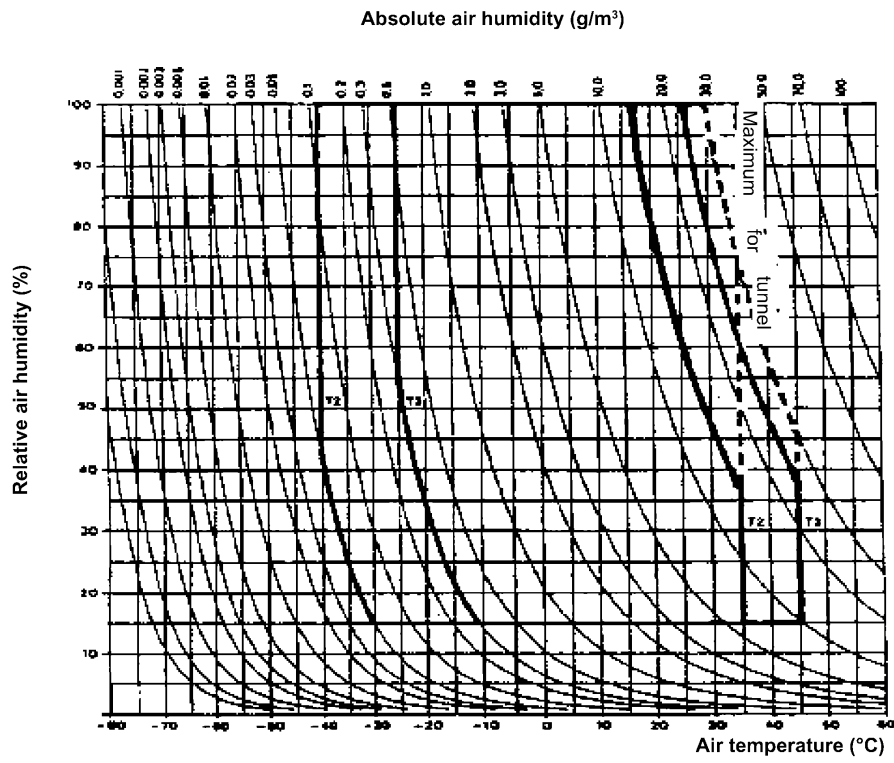



## ANNEX H

## INFRASTRUCTURE AND ROLLING STOCK REGISTER

## Rolling Stock register

## Requirements for the Freight Wagon Register

Data Item	Interoperability Critical	Safety Critical	Frequency of update
<b>Basic Data</b>			Annually
Vehicle number	√	√	
Owner			
Keeper	√	√	
Vehicle type (UIC 438-2)	√	√	
<b>Technical Information</b>			
Length over buffers	√	√	
Tare weight	√	√	
Coupling type	√	√	
Vehicle gauge	√	√	
Wheelset gauge	√	√	
Wheel diameter	√	√	
No. of axles and arrangement	√	√	
Position of wheelsets/inner wheelset distance/pivot pitch	√	√	
Bogie pitch (wheel base of the bogie)	√	√	
<b>Safety critical Information</b>			
Braking type	√	√	
Brake weight/braked weight %	√	√	
Deceleration curve	√	√	
Hand brake type	√	√	
Maximum speed (loaded)	√	√	
Maximum speed (empty)	√	√	
Maximum load	√	√	
Maximum axle load	√	√	
Dangerous goods information (several fields)	√	√	
<b>Information required for vehicle loading</b>			
Loading table	√	√	
Height of loading platform (for flat wagons and combined transport)	√	√	

**▼ B**

Data Item	Interoperability Critical	Safety Critical	Frequency of update
Loading restrictions (e.g. Weight distribution)	√	√	
<b>Registration Data</b>			
State of registration	√		
Date of putting into service	√		
Date of declaration of EC verification and Notified Body	√		
List of Interoperable Constituents fitted to wagon, IC identification and IC EC verification and date of declaration of EC verification, and Notified Bodies.	√	(√)	
Additional certification required for specific cases		(√)	
All previous vehicle numbers and corresponding registration dates	√	√	
<b>Maintenance Information</b>			
Maintenance plan reference	√	√	
<b>Restrictions</b>			
Geographical limitations	√	√	
Environmental limitations — temperature range T(n), T(s), T(RIV), T(n)+T(s)	√	√	
Hump shunting restriction	√	√	
Minimum curve radius	√	√	
Vertical curve restrictions	√	√	
Ferry use permitted	√	√	
Timescale restrictions	√	√	
<b>Tags</b>			
If fitted	√	√	

*Note* : A separate database(s) of keepers/owners/RUs will be required, identified from the R S Register by code nos.



**▼ B**

## ANNEX I

**INTERFACES OF BRAKING INTEROPERABILITY CONSTITUENTS**

## I.1. DISTRIBUTOR

The specification of the interoperability constituent distributor is described in 4.2.4.1.2.2 Braking Power and 4.2.4.1.2.7 Air Supply

## I.1.1. Distributor Interfaces

## I.1.1.1. Distributor valve

A distributor is a pneumatic control valve. Its function is to control its output pressure as an inverse function of the variation of its input pressure. See Figs. I.1 and I.2. The performance of a distributor is specified by the following:

- Graduable application and release of the brakes
- Brake Application Time
- Brake Release Time
- Manual Distributor Release Valve
- Automatic operation
- Sensitivity and Insensitivity

Fig.: I.1

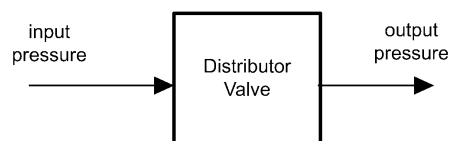
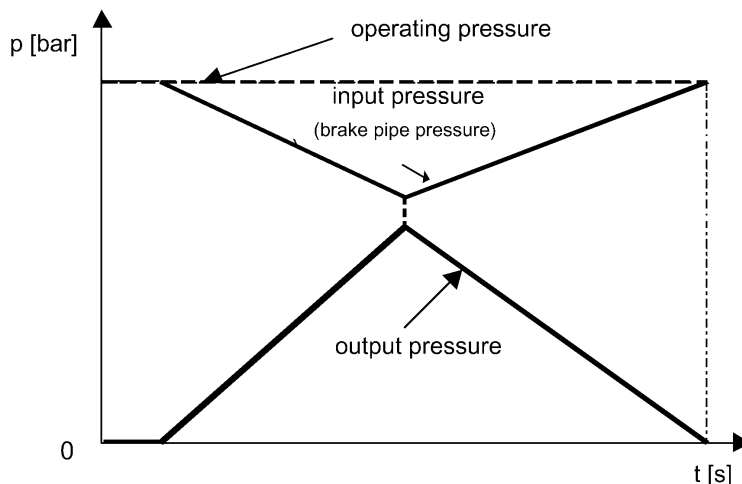

Fig.: I.2



The distributor is controlled by the pressure in the brake pipe. The normal operating pressure of the brake pipe in a train shall be 5 bar with the Driver's Brake Controller in the 'Release' position; however, the distributor shall function normally with a brake pipe pressure of 4 to 6 bar. The pressure drop in the brake pipe to obtain a full application must be  $1,5 \text{ bar} \pm 0,1$ . The maximum output pressure obtained with this drop is  $3,8 \text{ bar} \pm 0,1$ . The output pressure usually is limited to a maximum value. The normal operating pressure of the brake pipe is 5 bar, but the distributor must be able to operate normally with a brake pipe between 4 and 6 bar. The rate of change of the distributor output pressure shall be determined by the rate of change of the input pressure. (See Fig. I.3).

▼ B

Fig.: I.3

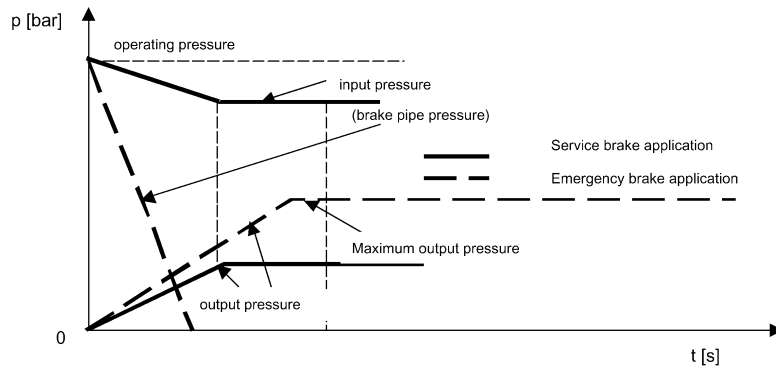

The distributor shall cause the brakes on a wagon to release by venting the brake cylinder pipe to atmosphere in response to an increase in brake pipe pressure following a brake application, see Fig. I.4.

Fig.: I.4

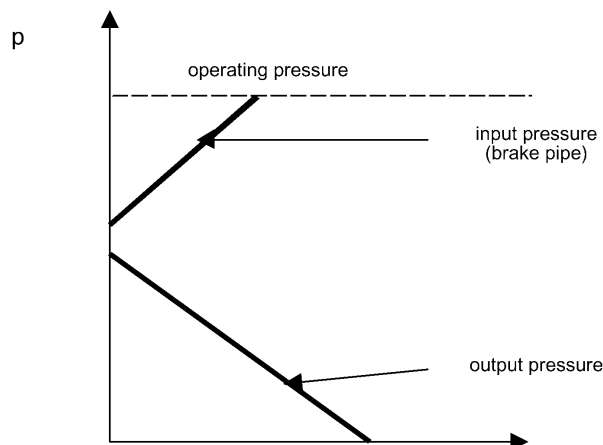

It shall be possible to make small applications and releases of the output pressure by varying the input pressure and a change of 0,1 bar on the input will cause a change in the output. The variation in output pressure with the same input pressure shall not vary more than 0,1 bar between an application and release.

The distributor shall not connect the brake pipe and reference control reservoir until the output pressure is less than 0,3 bar. This connection shall be allowed when the brake pipe has risen to within 0,15 bar of the operating pressure.

The Brake Application Time is the time for increasing output pressure from when it starts to rise from 0 bar up to 95 % of the maximum output pressure when input pressure is reduced to 0 bar in less than 2 seconds. This is 3 to 5 seconds in 'P' single stage, or 3 to 6 seconds in 'P' with a load/empty or load proportional brake, and 18 to 30 seconds in 'G' in a single-pipe operation.

The Release Time is the time for reducing the output pressure from when it starts to fall from maximum down to 0,4 bar when input pressure is increased up to the operating pressure starting from 1,5 bar below it, in less than 2 seconds. This is 15 to 20 seconds in 'P' and 45 to 60 seconds in 'G'. For freight wagons with a total weight higher than 70 tonnes the time in 'P' can be 15 to 25 seconds.

The distributor shall be able to be utilised either as 'G', 'P' or 'G/P' or in the latter case there will be a changeover device allowing the change over between the timings.

**▼ B**

There shall be a Manual Release Function, which requires deliberate and intentional manual action in order to cancel the brake application (to release the distributor valve).

The distributor must be Automatic and have the ability to ensure the maximum output pressure in case of loss of input pressure.

The distributor must be inexhaustible and have the capability to give at least 85 % of the maximum output pressure, by an emergency application, under all operating conditions. The distributor shall maintain the output pressure compensating for leakage in the output volumes whilst there is air in the auxiliary reservoir.

The filling of the auxiliary and control reservoirs on one vehicle shall be such that the release and filling of the reservoirs at the rear of the train are not impeded. It must also be such that there are not significant variations in the brake pipe pressure likely to cause operation of the brakes on the neighbouring vehicles.

The distributor must operate normally in response to the input pressure when adjacent distributors are isolated or not functioning.

The Sensitivity of the distributor will be such that it will come into operation within 1,2 seconds with an input pressure reduction of 0,6 bar in 6 seconds from the normal operating pressure.

The Insensitivity of the distributor is such that it will not come into operation with an input reduction from the normal operating pressure of 0,3 bar in 60 seconds.

Fig.: I.5

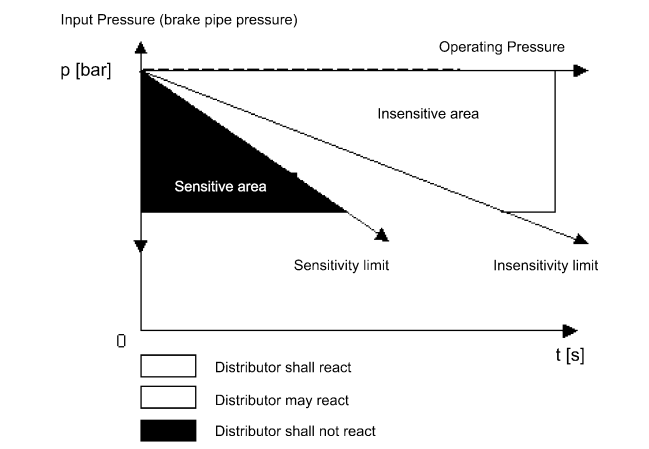

There shall be a Quick Service Function (accelerator) in a distributor valve which allows, when first applying the brake from the released position, the local fast venting of brake pipe pressure by a maximum of 0,4 bar when the brake pipe pressure at the front of the train falls by 0,3 bar. This is to provide pneumatic brake signal transmission through a train.

There can be an Operating pressure overcharge which allows a build up of brake pipe pressure above normal operating pressure to 6 bar to reduce the release time and this can be present for up to 40 seconds in 'G' mode and 10 seconds in 'P' mode. The distributor shall not overcharge the control reservoir during this brake pipe overcharge period. After a full release of the brakes the distributor shall not operate when the brake pipe pressure is raised to 6 bar for 2 seconds, then reduced to 5,2 bar in 1 second followed by a return to normal operating pressure.

The distributor shall have an Inshot function, which allows, when operated in the braking mode 'G', a faster increase of the output pressure at the beginning of brake application. This will be about 10 % of the maximum output pressure. The purpose is quick build up of the necessary pressure for initiating the friction braking process.

▼ B

Fig.: I.6

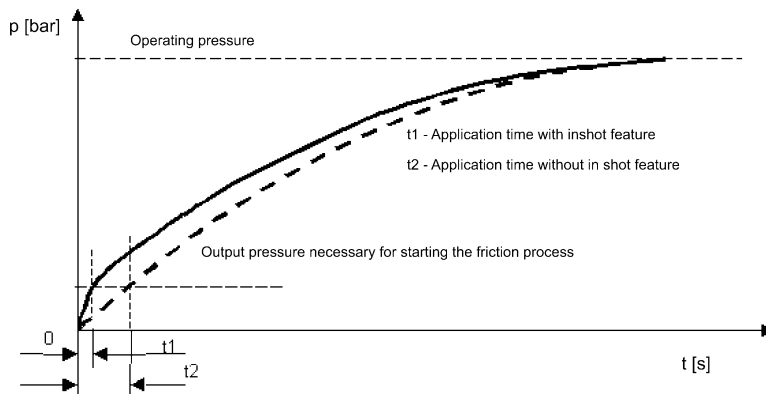

## I.2. RELAY VALVE FOR VARIABLE LOAD/AUTOMATIC EMPTY-LOAD CHANGE OVER BRAKE

### I.2.1. Relay valve for variable load

A relay valve is a device that varies the application force of the brake system according to the mass of the wagon. Changes in the mass of the wagon shall automatically and continuously cause the brake force to be varied without significant delay. It shall not react to short shocks or short variations of the load at the wheels. It shall not alter the performance characteristics of the air-brake (see TSI, ch. 5.3.3.1) except in the case of brakes with pneumatically-controlled devices for the variation of the braking power, the release time is the time which must elapse before a pressure of 0,4 bar is seen in the relay control chamber (pilot pressure). During braking, the established brake force due to a brake demand shall not be changed by this device. It shall provide a minimum of 5 steps of brake in the service range between minimum and maximum brake force in all cases from an empty to a loaded wagon. Any air consumption of this device shall be as low as possible and not have any effect on the braking of the vehicle.

### I.2.2. Relay valve for automatic empty/load change over

An Empty/Load relay valve is a device that varies the application force of the brake system at a single point in the mass range of a wagon. The empty or loaded position of this relay valve shall be automatically obtained when the mass of the wagon becomes respectively lower or higher than the changeover mass. Its performance shall not be affected by shocks and vibrations. A relay valve for empty/load must not alter the performance characteristics of the air brake (see TSI, ch. 5.3.3.1).

## I.3. WHEEL SLIDE PROTECTION DEVICE

A Wheel slide protection (WSP) device is part of a system designed to make the best use of available adhesion by a controlled reduction and restoration of the brake force to prevent wheel sets from locking and uncontrolled sliding, thereby optimising stopping distance. The WSP device shall not alter the functional characteristics of the brakes.

The speed of rotation of the wheelsets is calculated on the basis of information provided by sensors, and monitored by an automatic control system. These transmit commands to the WSP dump valves to reduce or restore braking power, either totally or partially.

The system shall take permitted wheel diameter differences on a given vehicle into account when evaluating speed.

The power supply to the WSP shall be so designed to ensure that the WSP powers up and that power is available when the vehicle is set in motion. WSP systems require a power supply to function and this can be provided by the vehicles or by the WSP itself.

WSP systems shall be designed to function correctly allowing for fluctuations in voltage of  $\pm 30\%$ . If the voltage fluctuation exceeds this limit, the WSP shall

**▼B**

shut down without disturbing the braking system. As soon as the supply voltage reverts to the permitted range, the WSP shall automatically return to normal functioning.

The WSP installation shall have its own protected circuit. Fuses or circuit breakers for the WSP shall be separated from others on the vehicle such that they cannot be confused with or operated in the same manner. Whenever there is power available, the WSP shall be supplied. Automatic cut-off of the supply is only permissible in the case of sleep-mode (no movement) or battery protection for battery safety reasons (degraded battery situation or low voltage caused by long-term lack of supply).

The WSP shall be designed to minimise air consumption.

Further specification of the interoperability constituent, wheel slide protection device, is described in 4.2.4.1.2.6 and 4.2.4.1.2.7 within the TSI.

**I.4. SLACK ADJUSTER**

Slack adjusters are necessary to automatically maintain a nominally constant clearance between the friction pair (wheel and brake block or disc and brake pad) in order to maintain the braking characteristics and guarantee the braking performance.

The slack adjuster shall not absorb more than 2 kN of the brake application force. The performance characteristics of the slack adjuster shall not be varied by environmental conditions (vibrations, winter conditions, etc.).

There is no requirement for interchangeability of slack adjuster, but if they are to be interchangeable the following space envelopes apply (only the values in the table are necessary).

Interchangeable Slack adjusters which are placed within the underframe shall not exceed the following space envelope:

— for loads up to a maximum of 75 kN.

*Fig.: I.7*

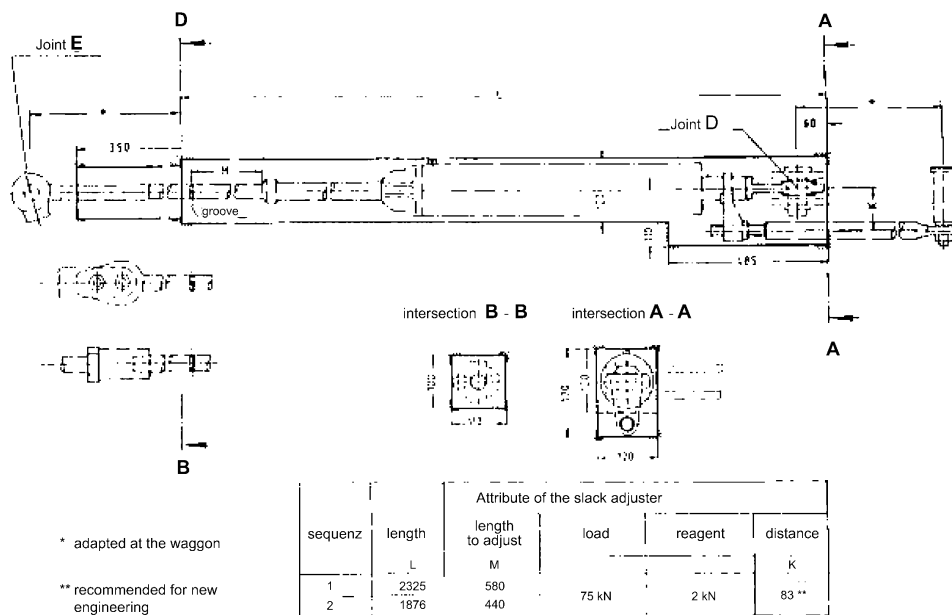

**▼B**

— for loads greater than 75 kN.

Fig.: I.8

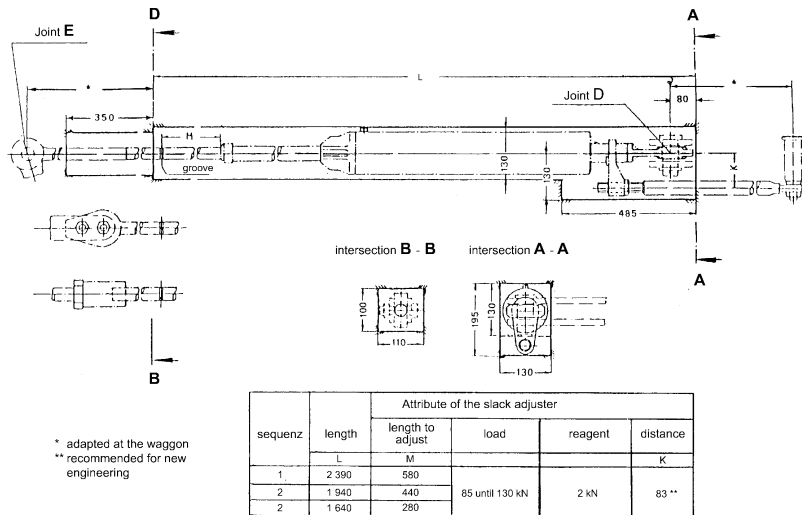

I.5. BRAKE CYLINDER/ACTUATOR

There is no requirement for interchangeability of brake cylinders/actuators, but if they are to be interchangeable the following clause applies (only the values in the table are necessary).

Interchangeable brake cylinders for use with a tread brake, that are placed in the underframe or in a bogie have to have the following connecting dimensions in figure I.9.1:

Fig.: I.9.1

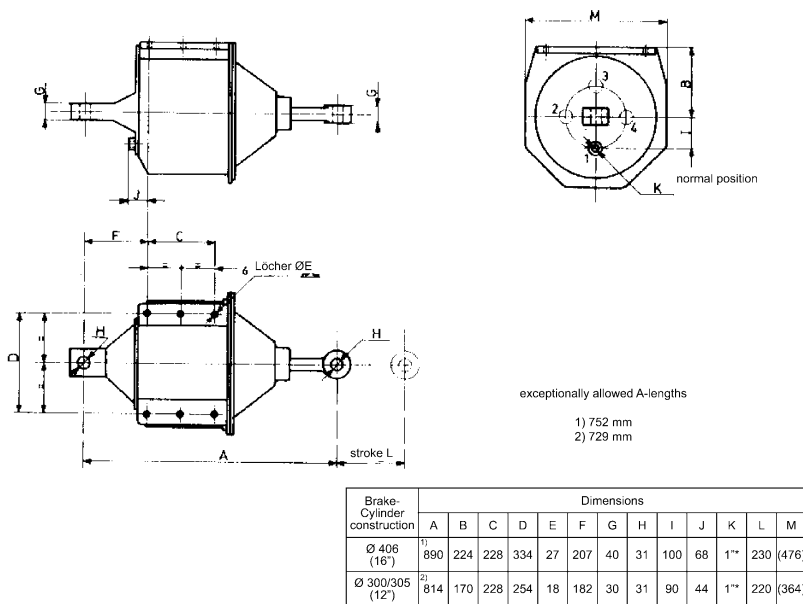

\* cylindric drilling GAZ - G 1 H

**▼B**

The diameters of the pins and bushes of the articulated joints of the interchangeable brake cylinders shall conform to the following figure I.9.2.

Fig.: I.9.2

**2-AXLE AND BOGIE WAGONS SUITABLE FOR ORDINARY, S AND SS (20+ PER AXLE) RUNNING CONDITIONS  
STANDARDISATION OF THE DIMENSIONS OF THE BRAKE RIGGING ARTICULATED JOINTS**

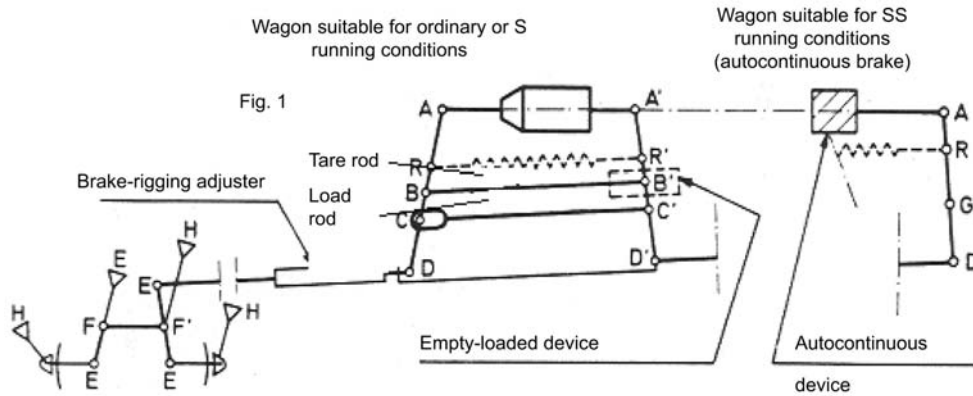
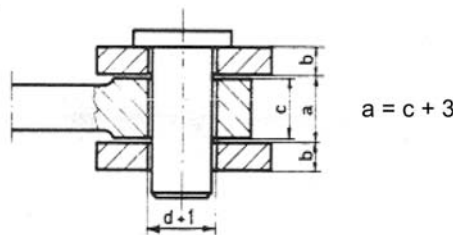

Fig. 2



		Diameter «d» of the pin (1)									b	c
		Articulated joints										
		A	B	C	D	E	F	G	H	R(4)		
Ordinary and S running conditions	Horizontal lever (2)	30	36	50	36	-	-	-	-	30	15	30 or 40 (6)
	Vertical lever (2)	-	-	-	-	36	50	-	24	-	20	40
SS running conditions	Horizontal lever (2)	36	-	-	40	-	-	60	-	30	20	40
	Vertical lever (3)	-	-	-	-	40	60	-	24	-	20 (5)	40

- (1) Steel Rm ≥ 370 N/mm<sup>2</sup> subjected to a suitable superficial hardening treatment.
- (2) Steel Rm ≥ 370 N/mm<sup>2</sup>.
- (3) Steel Rm ≥ 520 N/mm<sup>2</sup>.
- (4) In the case of an external return spring.
- (5) Thickness increased to 30 mm in the centre part.
- (6) 30 mm for 2-axle wagons (12" cylinder); 40 mm for bogie wagons (16" cylinder).

**I.6. PNEUMATIC HALF COUPLING**

The pneumatic half couplings for the automatic air brake pipe shall conform to Figs. I.10, I.12 and either I.13 or I.15. The nipple to connect to the end cock shall be as shown in Fig. I.10 and have a truncated internal Whitworth (BSPP) G 1 1/4" pipe thread.

The pneumatic half couplings for the main reservoir pipe shall conform to Figs. I.11, I.14 and either I.13 or I.15. The nipple to connect to the end cock shall be as shown in Fig. I.10 (and is the same as for the automatic air brake pipe) and have a truncated internal Whitworth (BSPP) G 1 1/4" pipe thread.

The internal diameter of the coupling hoses for both pipes shall be between 25 and 30 mm. The length shall be as shown in Figs. I.10 & I.11. The length of

▼**B**

these hoses when used with a swing head autocoupler shall be increased to 1080 mm for the automatic air brake pipe and 930 mm for the main reservoir pipe instead of the dimensions shown in I.10 & I.11. Rubber hoses will generally be used for these couplings, but metallic hoses may be used if they are flexible enough.

The coupling heads for the automatic air brake pipe shall conform to Fig. I.12. The coupling head for the main reservoir pipe shall conform to Fig. I.13. Both Figs. show the mandatory dimensions to ensure coupling, but the shape and the other dimensions are able to be varied provided the heads are designed to offer the least possible resistance to air flow. The coupling heads can be made as a single piece or two pieces as shown by the \* in Figs. I.12 & I.14. If the coupling head is made in a single piece the seal shown in I.13 shall be used, otherwise the seal shown in Fig. I.15 shall be used.

Fig. I.10

Note : Key to symbols used with dimensions in the Figs.

- Mandatory dimensions
- )...{ Minimum dimensions
- (....) Maximum dimensions
- \* Recommended dimensions

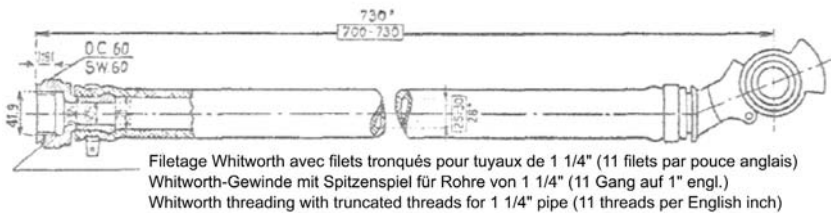
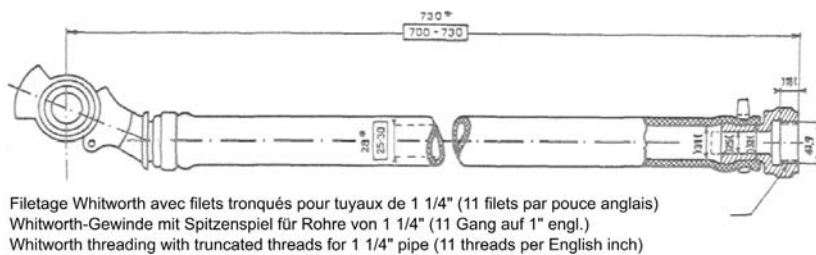

Fig. I.11

**Pneumatic half coupling — Main Reservoir Pipe**







**▼B**

couplers. Stops shall be provided at the extremes of rotation, so that the open and closed positions are achieved positively. The closed position is where the flow path between inlet and outlet ports is closed and the venting passage is open and connected to the pipe on the hose and coupling side of the cock. The cock handle is closed in the vertically upward position on the vehicle. The open position is where the flow path between inlet and outlet ports is fully open, and the venting passage is closed. The cock handle is open in the approximately horizontal position.

Where a control shaft is used to operate the end cock it must be possible for the plug to be fitted with a forked lever in such a way that the rotation angle between the extreme conditions of the cock be symmetrical in relation to the perpendicular line to the longitudinal centre line of the cock (see Fig. I.20).

**Venting port :** The end cock shall incorporate a venting port with a minimum area of 80 mm<sup>2</sup>, arranged so that when the cock is closed the compressed air from the coupling hose end of the cock (intake connection to vehicle) can be exhausted to atmosphere. Venting shall have commenced when the operation of the end cock has reduced the cross-sectional area of the bore of the end cock by one third. The venting port shall not be able to be obstructed when the cock is mounted on the end vehicle.

**Torque:** All end cocks with mechanical detent, or with latch engaged shall not be operated by vibration or shocks. The end cock shall be able to be manually operated so the torque shall reach a value in the range of 9 Nm to 20 Nm for end cocks with detent and a maximum of 6 Nm for cocks with latch.

**Spindle handle of the end cock :** Where the handle is detachable and the unique angular relationship between it and the spindle is not construction ally assured, it shall not be possible to assemble the handle to the spindle except where the axis of the handle and the diametrical spindle mark are aligned and the spindle shall be marked in accordance with Fig. I.16 or as otherwise specified by the purchaser. The relative position of the handle and spindle when assembled, shall remain under all conditions of operation and environment. If the handle of the end cock is detachable from the spindle it shall be positively located.

Fig. I.16

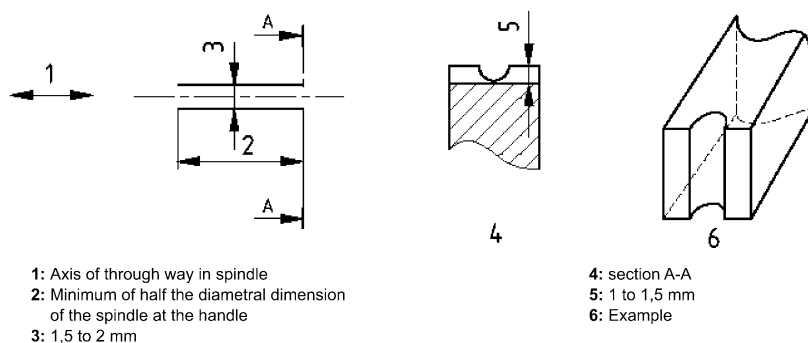
**Marking on end of the spindle**

**Fall time :** The air passages shall be designed to minimise the losses within the cock and the cross-sectional area shall not be smaller than the cross-sectional area of a plain pipe of 25 mm internal diameter. The fall time in pressure on opening the end cock should not be longer than that for an equivalent pipe of the same nominal diameter.

**Pneumatic shocks:** The components shall be able to resist the pneumatic shocks to which the cock is subject when opening quickly.

**Connections:** The body of the end cock shall have an internal Whitworth (BSPP) G1" or G1.1/4" thread, for connection to the brake or main reservoir pipe. The end of the body adjacent to the internal threads shall be of hexagonal form or have flats (see Fig. I.17). If required by the Purchaser, the body end can have a flat sealing face for Flange type of connections. The body of the end cock shall have an external thread for connection to the coupling hose in accordance with Fig. I.18.

▼ **B**

Fig. I.17

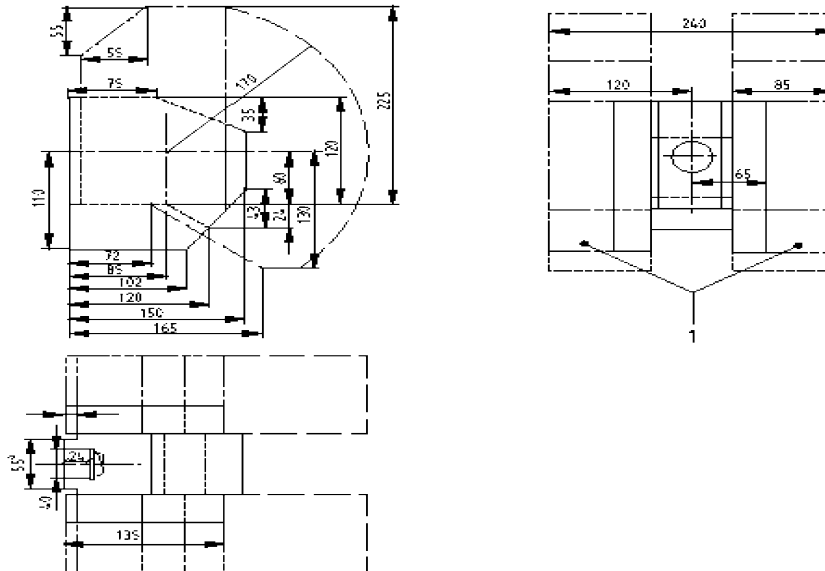
**Diagram showing the overall dimensions of the end cock***(Dimensional length unit is millimetre)*

1: The necessary space for operating the stop-cock handle is required either at left or right only.

R = 1" or R = 1¼"

11 threads to the inch

NOTE: The dot-and-dash line ----- indicates the maximum radius within which the handle can be manoeuvred.

<sup>(a)</sup> 60 mm may be used as an alternative

▼B

Fig. I.18

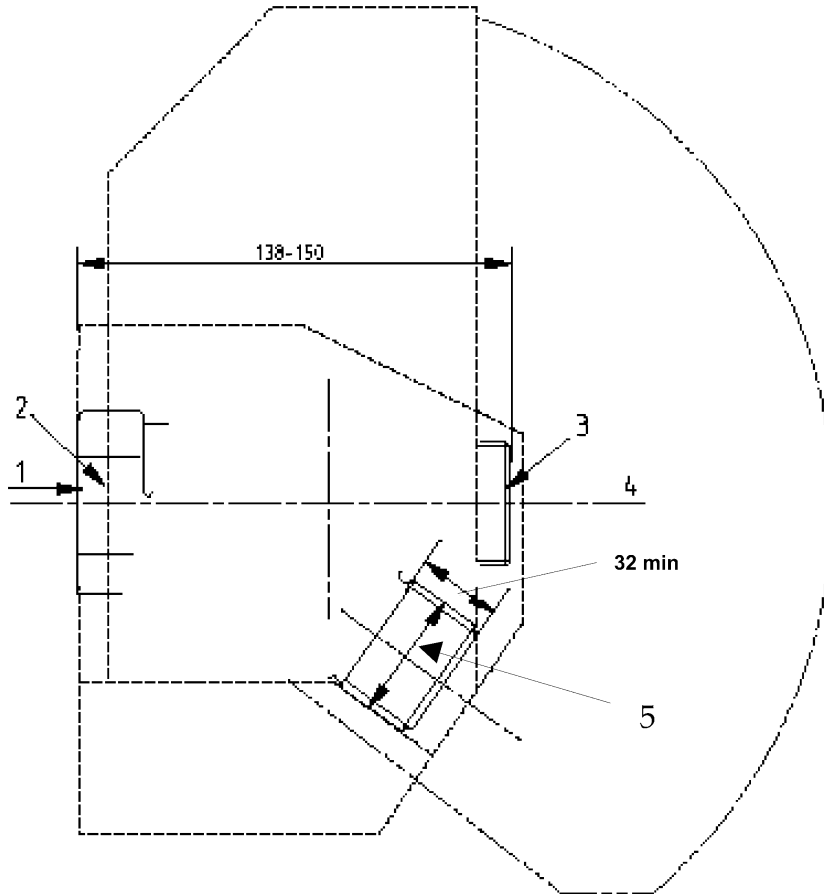
**End cock fitted with a spring locking device in the end positions***(Dimensional length unit is millimetre)*

- 1: R = 1" or 1¼"  
11 threads to the inch
- 2: Key opening width 55 mm  
The key opening width of 55 mm is the standard value. The opening width of 60 mm is permitted as an alternative.
- 3: Stop-cock in horizontal position.
- 4: Longitudinal centre line.
- 5: Whitworth threading with truncated threads for 1¼" pipes.

▼B

Fig. I.19

Diagram showing the overall dimensions of the end cock on vehicles fitted with automatic couplers

(Dimensional length unit is millimetre)

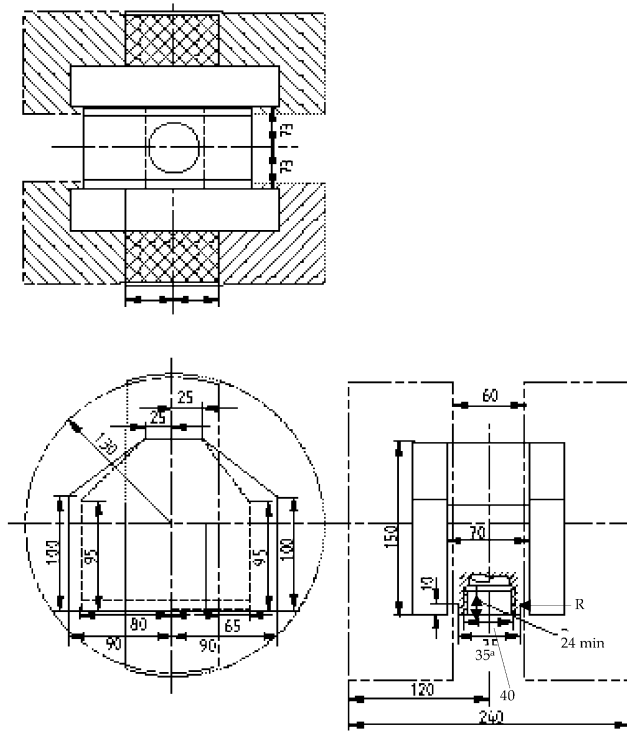

1: The necessary space for operating the stop-cock handle is required either at bottom or top of right-hand side or at bottom or top of left-hand side.

R = 1" or R = 1¼"

11 threads to the inch

NOTE: The dot-and-dash line ----- indicates the maximum radius within which the handle can be manouvered.

<sup>(a)</sup> 60 mm may be used as an alternative

▼B

Fig. I.20

**Connection dimensions for the end cock controls on vehicles equipped with automatic coupler**

(Dimensional length unit is millimetre)

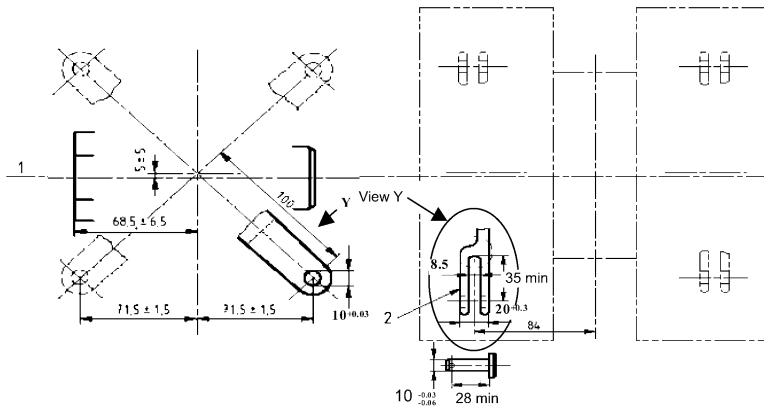

1:	Stop-cock
2:	Forked lever in vertical position
X:	The forked lever may be shaped differently in the X area if this proves to be necessary to keep within the distance from the stop-cock centre line (84 mm). The other end of the lever must be adapted to the stop-cock used.

**I.8. ISOLATING DEVICE FOR DISTRIBUTOR**

The handle of the isolating device must be in a vertical downward position when the brake is in use. Rotating the handle through a maximum angle of 90° shall isolate the brake. The cock handle shape shall conform to Fig. I.21

Fig. I.21

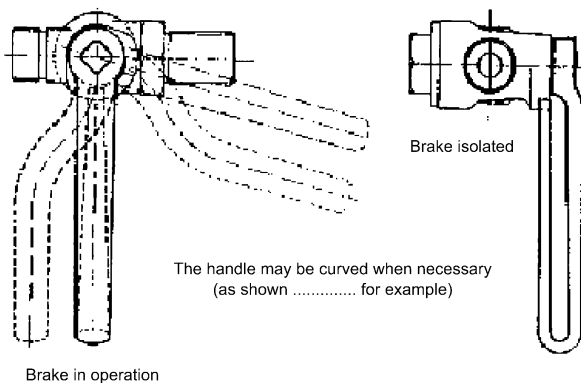

The isolating device shall be fitted to the vehicle in such a way that the isolated (closed) and active (open) positions are clearly visible and the device can be easily operated from one side of the vehicle.

It is recommended that the cock be fitted on the distributor or in close proximity to it.

**I.9. BRAKE PAD**

**I.9.1. Purpose**

The pad is to be used as part of the friction brake of a vehicle, which is capable of providing pre-defined retardation levels as specified by the purchaser, by being

**▼B**

applied to a brake disc friction face. The pad shall fulfil the following requirements:

- Permit a braking moment or torque to be generated
- Permit, by frictional engagement with a brake disc friction face, the conversion into heat of the kinetic and potential energy involved in retarding the vehicle or vehicles, which is attributed to the use of the disc brake.
- Act as part of a holding or parking brake by frictional engagement with a brake disc friction face.

**I.9.2. Operational**

The design and manufacture of the pad shall, for all intended operating conditions, take into account the following criteria.

**Performance**

- The maximum specified retardation to be achieved in full service and emergency braking conditions
- The rotational speed range of the brake disc
- The specified requirements for any holding or parking brake facility.
- The range of specific pressure of the pad friction surface on the disc friction face
- The type of material used in the manufacture of the brake disc friction face.
- The quantity of brake energy to be converted and its rate of conversion and dissipation
- The temperature of the brake disc friction face

**Service and life cycle costs**

- The integrity and wear rate of the pad friction material and brake disc friction face
- The need to prevent the detachment of any part of the friction material from the pad throughout its useable thickness.
- The need to prevent deformation of the pad backplane in any plane throughout the useable thickness of the friction material.

**I.9.3. Pad design**

The interface dimensions for the Interoperability Constituent brake pad shall conform to figures I.9.3.1 and I.9.3.2 for 200 cm<sup>2</sup> and 175 cm<sup>2</sup> brake pads.



▼B

Figure 9.3.1

BRAKE PAD (200 cm<sup>2</sup>)

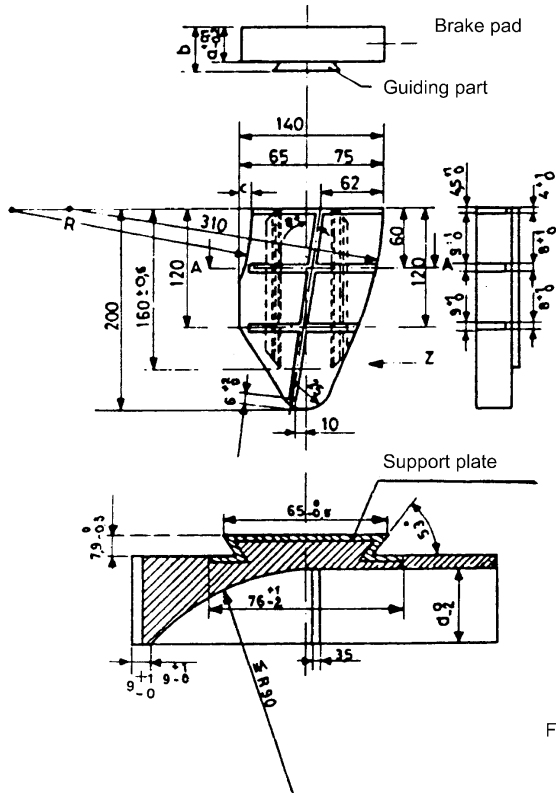

right-hand version  
(left-hand version : same drawing, but the other way round)

The size and shape of the grooves are only shown as an example

Friction area : 200 cm<sup>2</sup>

24	31,9	19	7,5	232,5
35	42,9	30	7,5	232,5
24	31,9	19	15	240
35	42,9	30	15	240
a	b	d	c	R

▼B

Figure 9.3.2

BRAKE PAD (175 cm<sup>2</sup>)

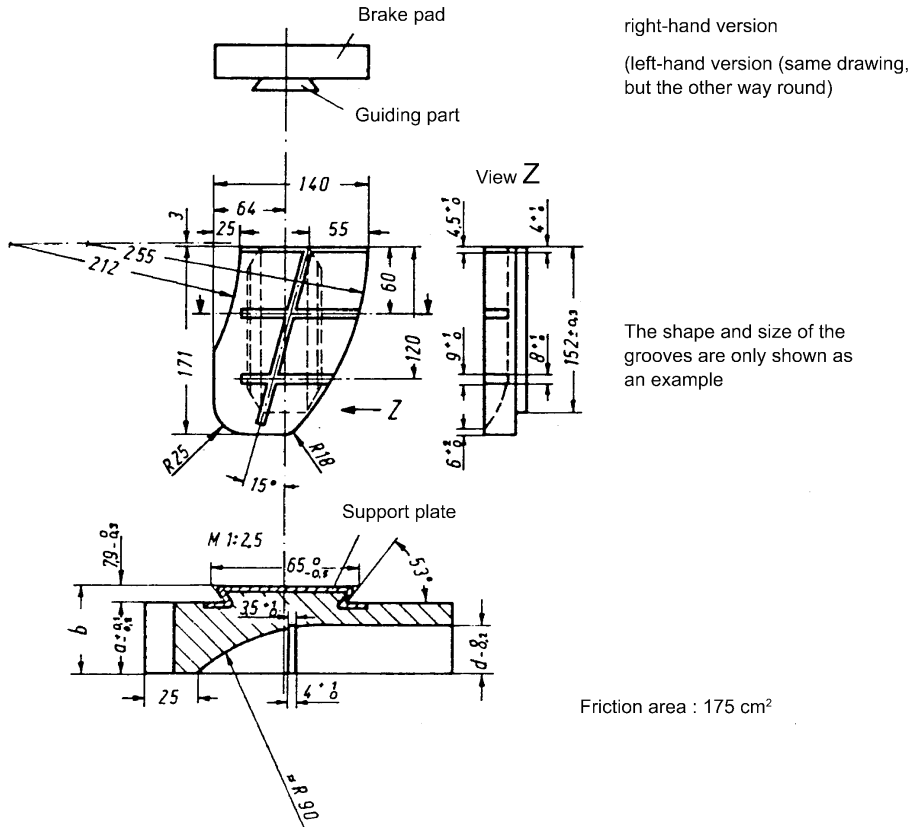

24	31,9	19
35	42,9	30
a	b	d

#### 1.9.4. Frictional Performance

##### General requirements

Pads of the same size, with the same nominal friction coefficient and used in the same application, may produce different frictional characteristics depending on the pad material type and formulation.

As far as possible, the friction coefficient must be independent of the initial braking speed, the specific pressure on the brake disc friction face, the temperature of the friction face and atmospheric conditions. The friction coefficient should also be independent of the degree of bedding of the pad friction surface on the brake disc friction face

##### Specific requirements

The purchaser shall supply details of the range of duty level (maximum speed/braked load per disc/deceleration/disc type and material/any other specific requirements) that the pad should be capable of meeting.

▼ **B****I.10. BRAKE BLOCKS****I.10.1. Purpose**

The block is to be used as part of the friction brake of a vehicle, which is capable of providing pre-defined retardation levels as specified by the purchaser, by being applied to the tread of the wheel. The block shall fulfil the following requirements:

- Permit a braking moment or torque to be generated
- Permit, by frictional engagement with the wheel tread, the conversion into heat of the kinetic and potential energy involved in retarding the vehicle, or vehicles, which is attributed to the use of the tread brake.
- Act as part of a holding or parking brake by frictional engagement with the wheel tread.

**I.10.2. Materials**

The brake block, in the case of maintenance related replacement only, can be manufactured in cast iron, composite or sintered material. For sintered blocks, as far as possible, the friction coefficient must be independent of the initial braking speed, the specific pressure on the wheel tread, the temperature of the friction face and atmospheric conditions. The friction coefficient should also be independent of the degree of bedding of the block friction surface on the wheel tread.

This Annex does not provide any specification related to composite blocks.

**I.10.3. Interface with Block Holder**

The interface dimensions for the single block and double block format, and the key to secure them shall conform to Fig I.10.3.1 for cast iron blocks 320 mm long and Fig I.10.3.2 for double blocks 250 mm long. Fig I.10.3.3 shows the special features to be observed in order to ensure interchangeability of composite blocks of the same type and non-interchangeability with cast iron blocks for blocks 320 mm long. Fig I.10.3.4 shows the equivalent features for double composite blocks 250 mm long.

See figures below

Fig I.10.3.1

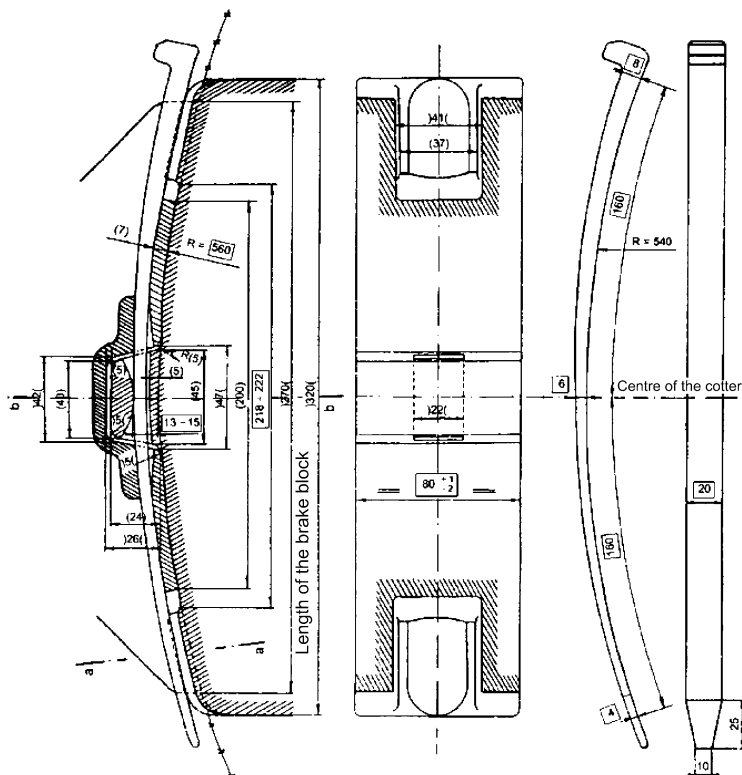
**Part 1**

▼B

Fig I.10.3.1

Part 2

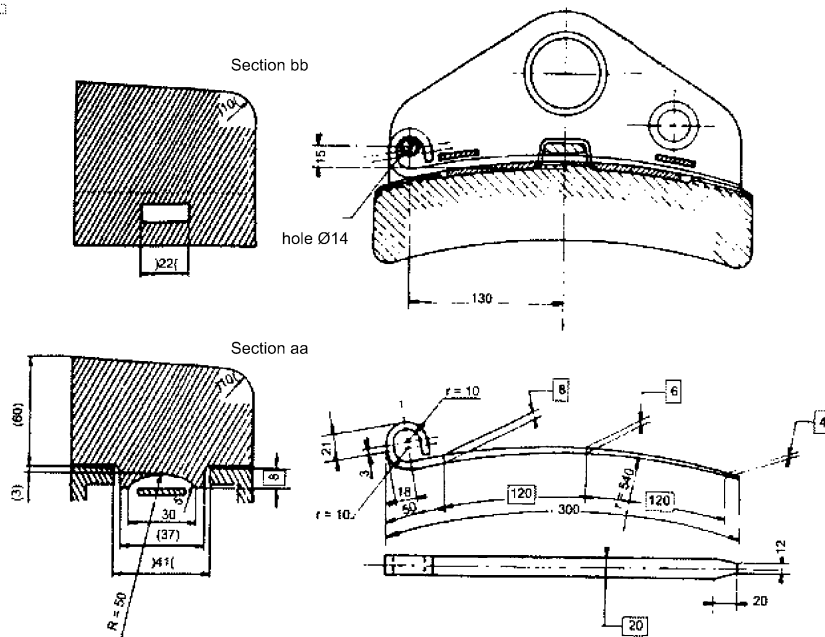

Type of cotter for side tipping wagon

	Minimum bearing surface of the brake block holder and the brake block
	Neither the brake block holder nor the brake block may pass this line where the contact surfaces are concerned
	The dimensions are obligatory
	The dimensions are minimum dimensions
	The dimensions are maximum dimensions
	Equal dimensions
<b>NB:</b>	The other dimensions are recommended

▼B

Fig I.10.3.2  
part 1

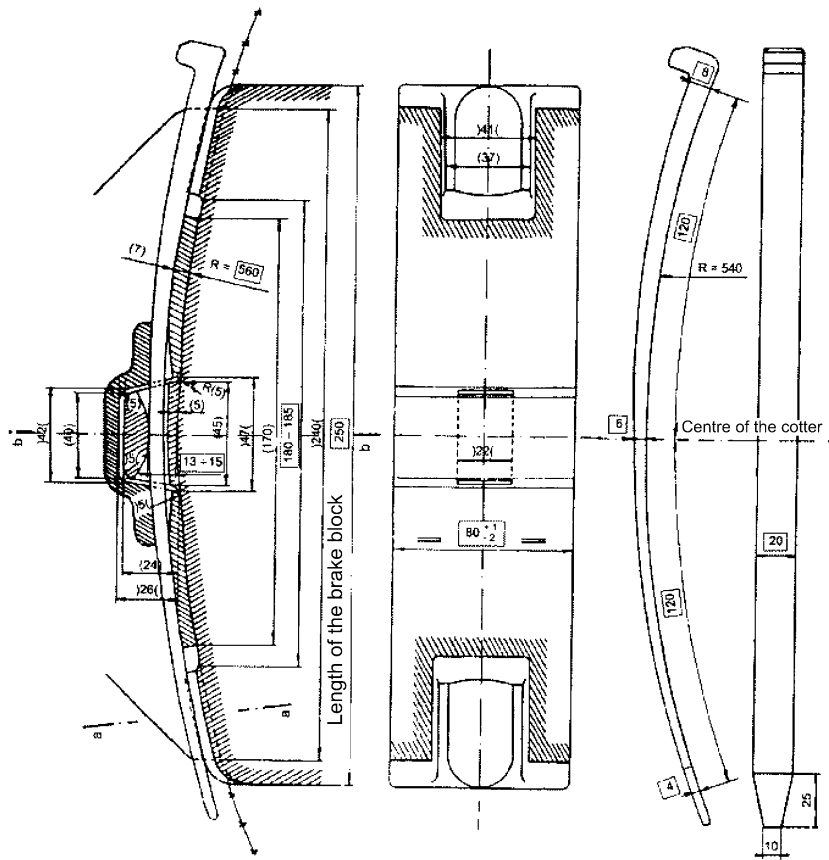

▼B

Fig I.10.3.2  
part 2

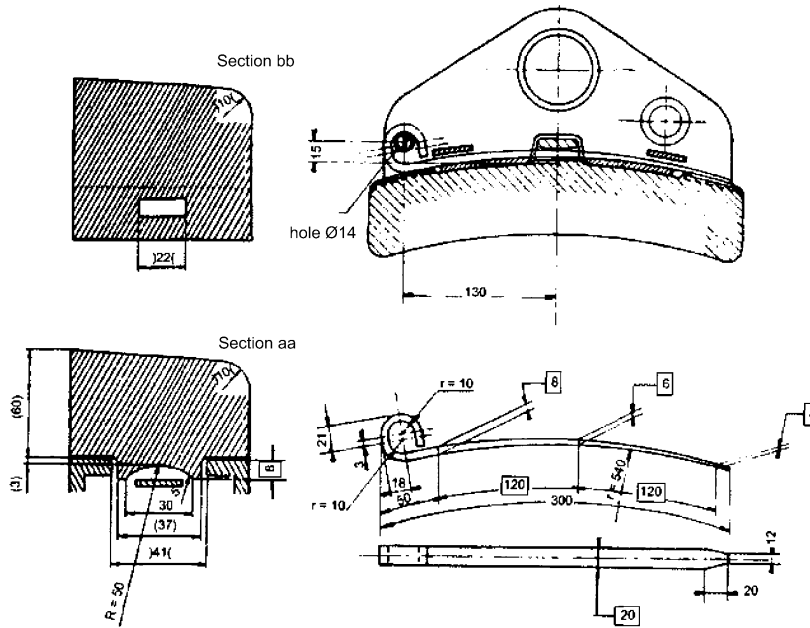

Type of cotter for side tipping wagon

	Minimum bearing surface of the brake block holder and the brake block
	Neither the brake block holder nor the brake block may pass this line where the contact surfaces are concerned
	The dimensions are obligatory
	The dimensions are minimum dimensions
	The dimensions are maximum dimensions
	Equal dimensions
<b>NB:</b>	The other dimensions are recommended

▼B

Fig I.10.3.3

All other dimensions as Fig I.10.3.1

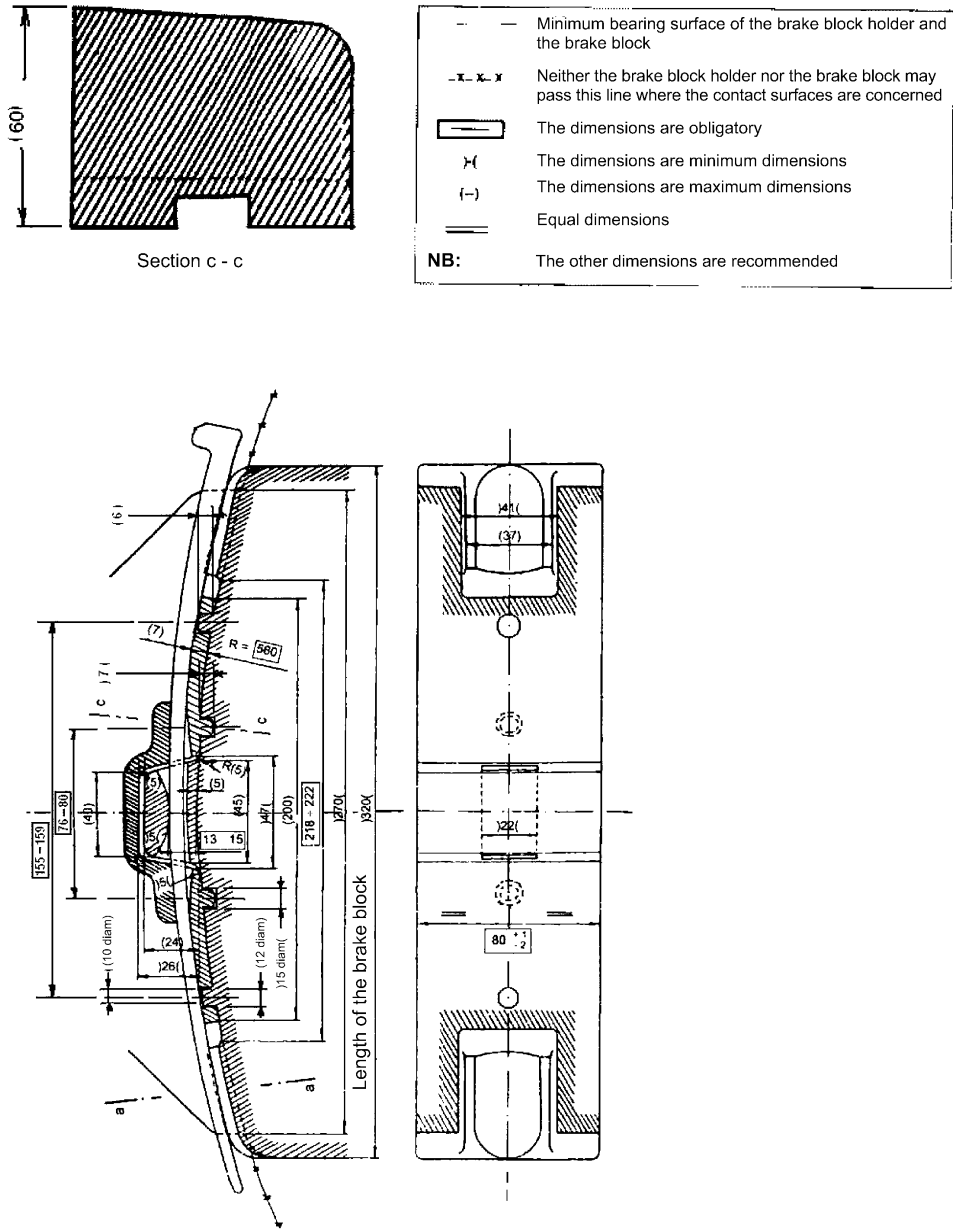

▼B

Fig I.10.3.4

All other dimensions as Fig I.10.3.2

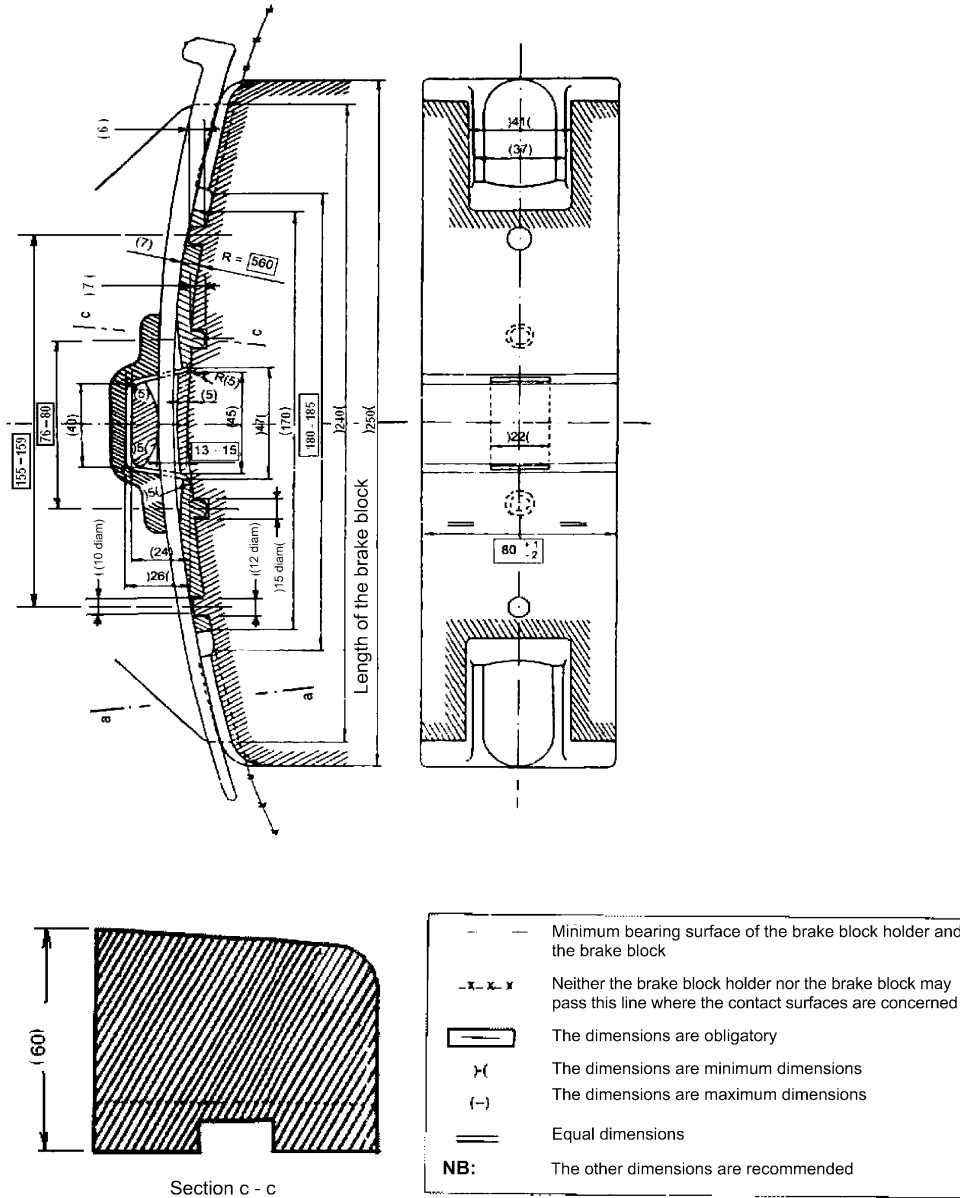

I.11. BRAKE PIPE EMPTYING ACCELERATOR VALVE

A brake pipe emptying accelerator valve is a device connected to the brake pipe of a vehicle, which operates in response to seeing a rapid fall in brake pipe pressure to ensure a continuing rapid fall to below 2.5 bar.

Brake pipe emptying accelerators shall be able to operate with all interoperable distributors and existing interoperable brake pipe emptying accelerators. The brake pipe-emptying accelerator shall be ready to operate when the brake pipe has reached its operating (running) pressure. The following operating conditions are defined in relation to a 5 bar brake pipe operating (running) pressure, but no functional errors shall occur in the operation of brake pipe emptying accelerator at operating (running) pressures of between 4 and 6 bar.

When an emergency brake application occurs, the brake pipe emptying accelerators shall create a sufficiently rapid reduction in brake pipe pressure to ensure the rapid increase in brake cylinder pressure on every vehicle in the train set. When the pressure in the brake pipe has fallen quickly to below 2.5 bar, and within no more than 4 seconds after the accelerator commences operation, the



**▼B**

accelerator shall stop venting air in such a way that the brake pipe can rapidly be refilled.

The brake pipe-emptying accelerator shall exhaust the air from the brake pipe without causing any adverse effect on vehicle/train behaviour.

The brake pipe emptying accelerator shall not come into operation due to the effect of an operating pressure overcharge, which allows a build up of brake pipe pressure above normal operating pressure to 6 bar and this can be present for up to 40 seconds in 'G' mode and 10 seconds in 'P' mode. The brake pipe emptying accelerator shall not come into operation after a full release if the brake pipe is raised to 6 bar for 2 seconds and reducing it to 5.2 bar in 1 second followed by a return to normal operating pressure.

The operation of the brake pipe-emptying accelerator shall not be affected by an individual vehicle, where a brake pipe emptying accelerator is not fitted or the brake has been isolated. This shall apply irrespective of the position of that vehicle and of the train consist.

The brake pipe emptying accelerator shall not come into operation when an emergency brake application is made after a full service brake application.

The brake pipe emptying accelerator shall come into operation no later than 2 seconds after the pressure in the brake pipe has fallen from 5 to 3.2 bar within 3 seconds.

The brake pipe emptying accelerator shall not come into operation when the pressure in the brake pipe falls uniformly from 5 to 3.2 bar over 6 seconds with the brake inoperative. When the brake is operative the brake pipe is to fall at the same rate (5 to 3.2 bar over 6 seconds), but down to 2.5 bar without the brake pipe emptying accelerator operating.

The brake pipe emptying accelerator shall not operate during the initial stage of service braking due to operation of the internal distributor accelerator valve. This test is carried out on a test rig giving the brake pipe fall as shown on Fig. I.22. The test rig shall drop the brake pipe from 5 to 4.5 bar within 1 second, with the initial rate of 2 bar/second from 5 to 4.7 bar. The brake pipe emptying accelerator shall not come into operation during this test.

If the brake pipe emptying accelerator is incorporated in the distributor, it must be inoperative after the brake has been isolated.

Fig. I.22

**Insensitivity test conditions**

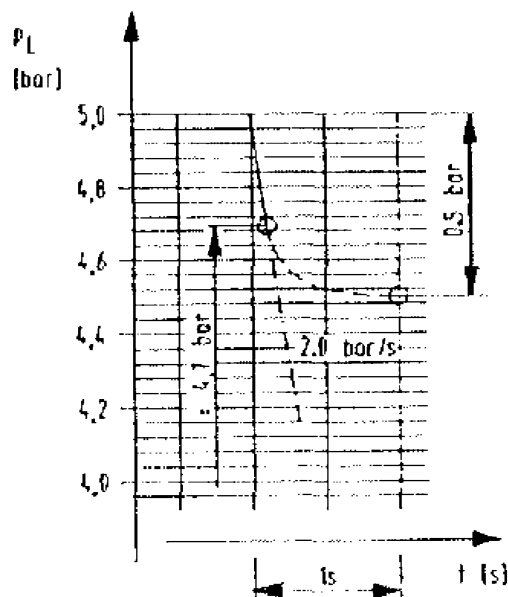

**▼B****I.12. AUTOMATIC LOAD SENSING & EMPTY/LOAD CHANGEOVER DEVICE****I.12.1. Continuous Load Sensing Device**

The transmission of the variation in load to the braking control system (variable load relay) can be purely mechanical or pneumatic. The method of producing the pneumatic signal can be a mechanically operated pneumatic device, a hydraulic to pneumatic converter device or an elastomeric to pneumatic converter device. The maximum control pressure produced by any pneumatic system when the wagon is fully loaded shall not exceed 4.6 bar.

**I.12.2. Empty/Load Changeover device**

The transmission of the variation in load (empty or loaded) to the braking control system (empty/load relay) can be purely mechanical or pneumatic. The method of producing the pneumatic signal can be a mechanically operated pneumatic device, a hydraulic to pneumatic converter device or an elastomeric to pneumatic converter device. If the pneumatic device is one producing a step in signal pressure between empty and loaded, the automatic empty/loaded changeover device shall operate safely — correctly with a minimum control pressure of 3 bar in 'loaded'.

**▼ B***ANNEX J***VEHICLE TRACK INTERACTION AND GAUGING****Bogie and running gear****J.1. STATIC TESTS WITH EXCEPTIONAL IN-SERVICE LOADS****Definitions of Applied Loads**

The applied loads consist of:

- vertical and transverse loads,
- loads due to roll,
- loads due to braking,
- torsional loads.

**Vertical and Transverse Loads**

The vertical and transverse loads are calculated by reference to the nominal bogie load (for example: bogie for 20 t or 22,5 t on-rail axle load).

In order to take the maximum dynamic load into account:

- The vertical load to be applied to the pivot bearing shall be:
- $F_z \text{ max.} = 1,5 F_z$ , with  $F_z = 4Q_0 - m^+ g$  (for 2-axle bogies)
- $F_z \text{ max.} = 1,5 F_z$ , with  $F_z = 6Q_0 - m^+ g$  (for 3-axle bogies)

If only the vertical load due to bounce is to be simulated, a load of  $2 F_z$  shall be applied to the pivot bearing only.

The transverse load to be applied to the bogie shall be:

- $F_y \text{ max.} = 2 \left( 10 + \frac{2Q_0}{3} \right)$  kN (for two-axle bogies)
- $F_x \text{ max.} = \frac{8}{3} \left( 10 + \frac{2Q_0}{3} \right)$  kN (for three-axle bogies)

NB: The transverse loads for 3-axle bogies given are based on the load distribution recorded during running trials for the qualification of bogie type 714. For a different bogie type, the load distribution recorded during running trials with the bogie type shall be used.

**Loads due to roll**

The roll coefficient  $\alpha$  is taken to be equal to 0,3 for a spacing between the friction pads of 1 700 mm (standard 2-axle bogies).

If the spacing between the friction pads ( $2 b_g$ ) differs from 1 700 mm, the value for  $\alpha$  should be:

$$\alpha = 0,3 \left( \frac{1700}{2b_g} \right)$$

**Loads Due To Braking**

The loads due to braking  $F_B$  correspond to 120 % of the forces resulting from emergency braking.

On the bogie under test, these loads due to braking  $F_B$  result in:

- deceleration loads,
- contact loads,
- loads applied to the brake linkages.

**▼B****Torsional Loads**

Loads on the bogie frame, when the bogie with its suspension is subjected to a maximum track twist of 10 %.

**Test Procedure**

Strain gauges and strain rosettes are attached to the bogie frame at all highly stressed points, in particular in zones of stress concentration. Positioning of the gauges shall be determined, for example, by means of strain indicating varnish.

The test shall be carried out in accordance with Figure 1 and Table J5 (for 2-axle bogies) or Figure 2 and Table J6 (for 3-axle bogies).

The test loads shall be applied in steps. Loads with values corresponding to 50 % and 75 % of the maximum values shall be applied before applying the full load configuration.

**Results To Be Obtained**

The elastic limit of the material shall not be exceeded for any load case.

After removal of the test load there shall not be any evidence of permanent deformation.

▼ **B**

Static Tests With Exceptional In-Service Loads— two axle bogies

Figure J1

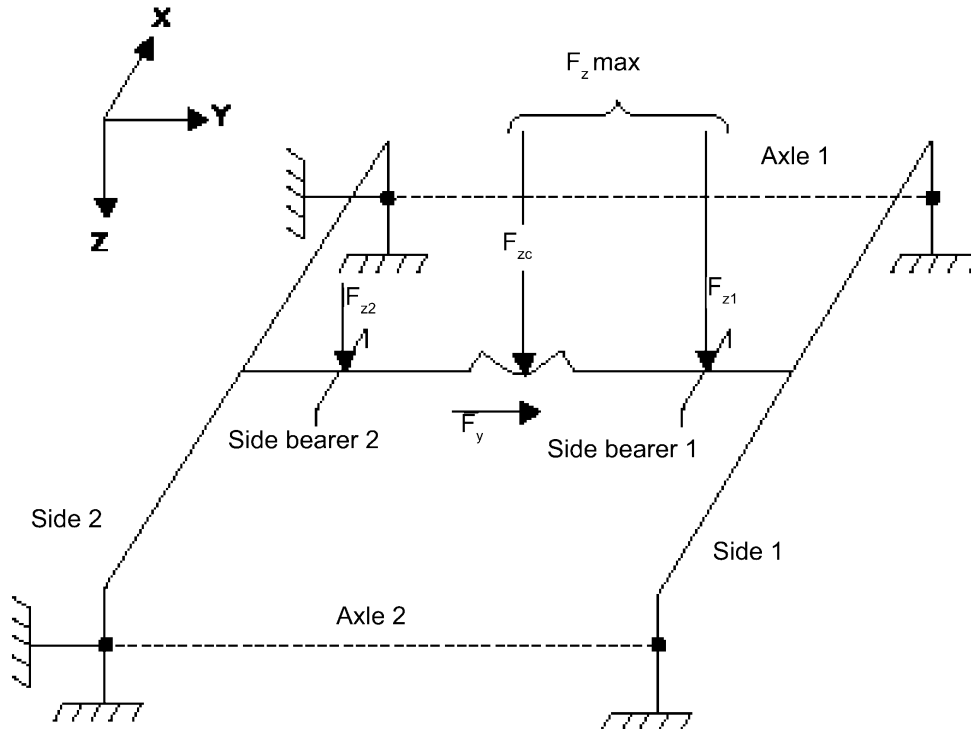

Table J5

Load case	Loads				Track twist g <sup>+</sup>	Braking forces
	Vertical			Trans-verse		
	Friction pad 2 F <sub>z2</sub>	Pivot bearing F <sub>zc</sub>	Friction pad 1 F <sub>z1</sub>	F <sub>y</sub>		
1		2F <sub>z</sub>				
2	0	(1-α) F <sub>z</sub> max	α F <sub>z</sub> max		10 ‰	
3	0	(1-α) F <sub>z</sub> max	α F <sub>z</sub> max	F <sub>y</sub> max		
4	α F <sub>z</sub> max	(1-α) F <sub>z</sub> max	0	-F <sub>y</sub> max		
5	0	1,2 F <sub>z</sub>	0			F <sub>B</sub>

$$F_z = 4Q_0 - m^+ g$$

$$F_y \text{ max} = 2 \left( 10 + 2 \frac{Q_0}{3} \right)$$

$$F_z \text{ max} = 1,5 F_z$$

$$F_B = \text{Braking forces}$$

$$\alpha = 0,3 \left( \frac{1700}{2b_g} \right)$$

▼ **B****Static Tests With Exceptional In-Service Loads— Three Axle Bogies**

Figure J2

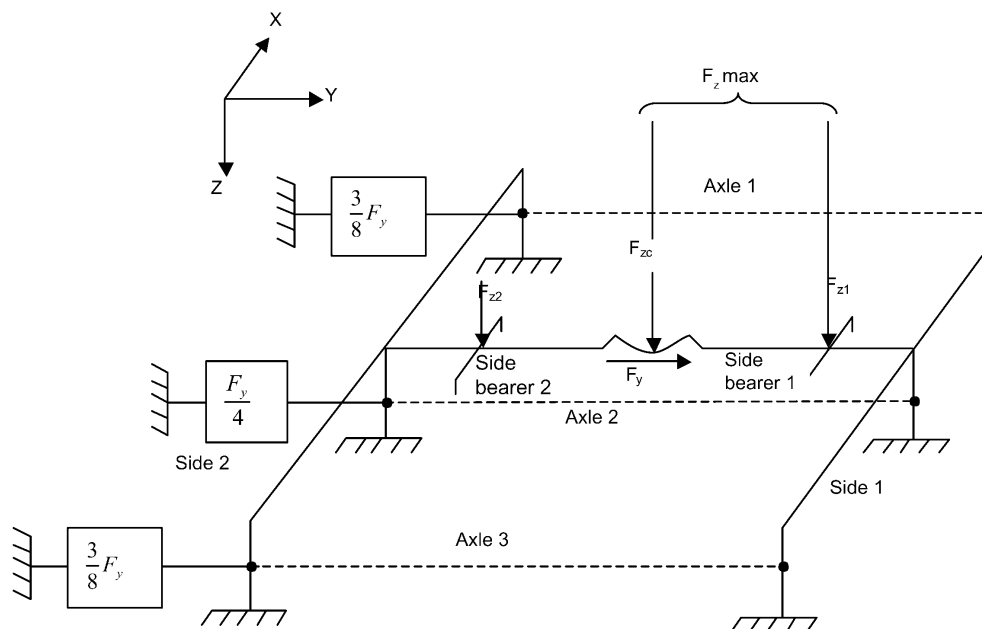

Table 6

Load Case	Loads				Track Twist g <sup>+</sup>	Braking Force
	Vertical			Transverse		
	Friction pad 2 F <sub>z2</sub>	Pivot Bearing F <sub>zc</sub>	Friction Pad 1 F <sub>z1</sub>	F <sub>y</sub>		
1		2 F <sub>z</sub>				
2	0	(1-α) F <sub>z</sub> max	α F <sub>z</sub> max		10 ‰	
3	0	(1-α) F <sub>z</sub> max	α F <sub>z</sub> max	F <sub>y</sub> max		
4	α F <sub>z</sub> max	(1-α) F <sub>z</sub> max	0	-F <sub>y</sub> max		
5	0	1,2 F <sub>z</sub>	0			F <sub>B</sub>

$$F_z = 6Q_0 - m^+ g$$

$$F_y \text{ max} = \frac{8}{3} \left( 10 + 2 \frac{Q_0}{3} \right)$$

$$F_z \text{ max} = 1,5 F_z$$

$$F_B = \text{Braking force}$$

$$\alpha = 0,3 \left( \frac{1700}{2b_g} \right)$$

**J.2. STATIC TESTS WITH NORMAL IN-SERVICE LOADS****Definitions of applied loads.**

The applied loads consist of:

— vertical loads on the pivot bearing and friction pads,

**▼ B**

- a transverse load,
- loads due to braking,
- torsional loads.

**Vertical loads and loads due to roll**

The vertical loads on the pivot bearing and friction pads shall be calculated by reference to the nominal bogie load. They depend on:

- $F_z$ , the static load exerted by the wagon body on each bogie
- $\alpha$ , the roll coefficient
- $\beta$ , the bounce coefficient

The roll coefficient  $\alpha$  is taken to be equal to 0,2 for a spacing between the friction pads of 1 700 mm (standard 2-axle bogies).

If the spacing between the friction pads ( $2b_g$ ) differs from 1 700 mm, the value for  $\alpha$  should be:

$$\alpha = 0,2 \left( \frac{1700}{2b_g} \right)$$

The bounce coefficient  $\beta$  that represents the vertical dynamic behaviour of the bogie shall be taken to be equal to 0,3 (the normal value for wagon bogies).

**Transverse load**

The transverse load shall be equal to:

- $F_y = 0,4 \times 0,5(F_z + m^+ g)$  (for 2-axle bogies)
- $F_y = 0,53 \times 0,5(F_z + m^+ g)$  (for 3-axle bogies)

**Loads Due To Braking**

The loads due to braking correspond to 100 % of the forces resulting from emergency braking.

On the bogie under test, these loads due to braking result in the following loads being applied:

- deceleration loads
- contact loads
- Loads applied to the brake linkages

**Torsional Loads**

Track twist, referenced to the bogie wheelbase, is taken to be equal to 5 ‰.

This twist  $g^+$  shall be simulated either by moving the supports or by applying the corresponding calculated reaction forces.

**Test Procedure**

Strain gauges and strain rosettes shall be attached to the bogie frame at all highly stressed points, in particular in zones of stress concentration.

**▼ B**

The test consists of applying various load configurations to the bogie frame that simulate:

- running on straight track
- running in curves
- dynamic load variations due to roll and bounce
- braking
- track twist

The various load cases to be applied are described in Figure 3 and Table 7 (for two-axle bogies) and Figure 4 and Table 8 (for three-axle bogies).

After application of the first seven load cases without simulation of track twist, four further tests shall be carried out by repeating load cases 4, 5, 6 and 7 with superposition of the track twist (value as specified for the bogie with its suspension).

For each of these four new load cases, the loads due to twist shall be applied first in one direction and then in the other.

The introduction of the track twist shall not modify the sum of the vertical forces.

Tests with application of loads corresponding to the loads due to braking shall be carried out if the results of the tests according to Appendix A show them to be necessary (elastic limit exceeded during those tests).

**Results To Be Obtained**

At each measuring point, the stresses  $\sigma_1 \dots \sigma_n$  shall be recorded for each of the load cases defined above.

From these  $n$  values, the minimum value  $\sigma_{\min.}$  and the maximum value  $\sigma_{\max.}$  are taken in order to determine:

$$\sigma_{\text{mean}} = \frac{\sigma_{\text{max}} + \sigma_{\text{min}}}{2}$$

$$\Delta\sigma = \frac{\sigma_{\text{max}} - \sigma_{\text{min}}}{2}$$

The behaviour of materials, including welded joints and other types of fastening, under fatigue loading should be based on current international or national standards, or alternative sources of equivalent standing such as the one based on ERRI B12 Committee report RPI7, wherever such sources are available.

Suitable data shall generally exhibit the following characteristics:

a high probability of survival (i.e. preferably 97,5 %, but at least 95 %);

classification of details according to the component or joint geometry (including stress concentration);

derivation of the limiting values from small-scale samples using a test technique and previous experience to guarantee their applicability to full size components.

If the stress limits to be respected are those given in the fatigue strength diagrams in ERRI B12 Committee report RPI7, it will be permissible to exceed these stress limits by up to 20 % at a limited number of measurement points, which shall then be monitored with particular care during the fatigue testing. If no incipient cracks are found during testing, the stresses exceeding the limit recorded during static testing shall be accepted and the bogie shall be approved.



▼ B

Static Tests With Normal In Service Loads— Two Axle Bogies

Figure J3

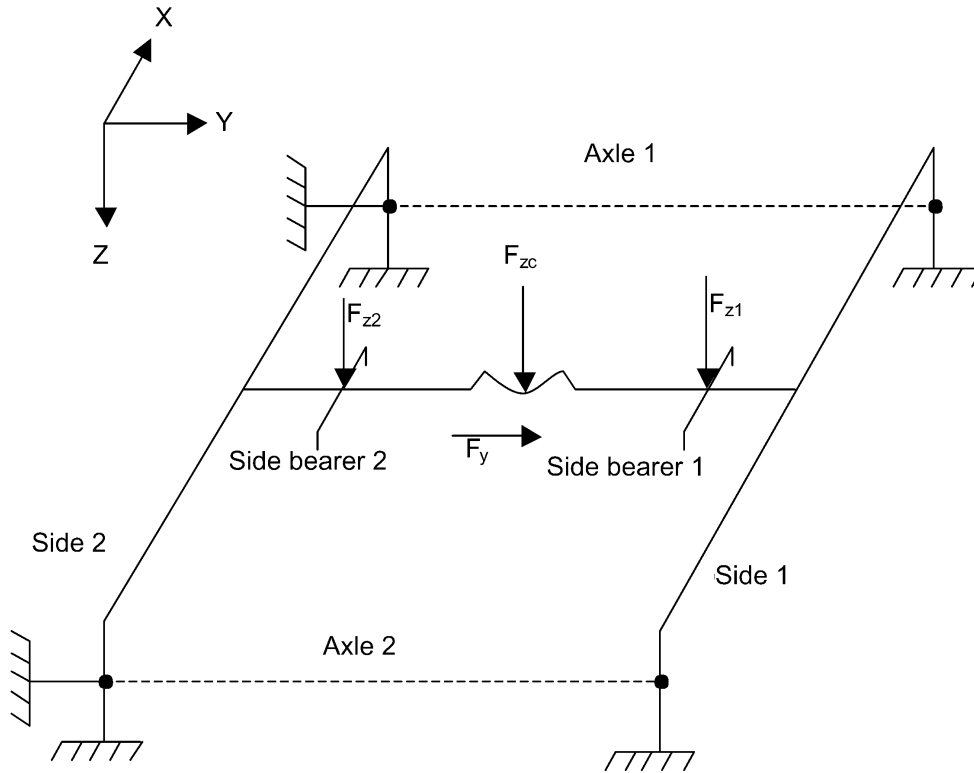

Table J7

Load Case	Loads				Braking Forces
	Vertical			Transverse	
	Friction pad 2 $F_{z2}$	Pivot Bearing $F_{zc}$	Friction Pad 1 $F_{z1}$	$F_y$	
1	0	$F_z$	0		
2	0	$(1+\beta)F_z$	0		
3	0	$(1-\beta)F_z$	0		
4	0	$(1-\alpha)(1+\beta) Fz$	$\alpha(1+\beta)F_z$	$F_y$	
5	$\alpha(1+\beta)F_z$	$(1-\alpha)(1+\beta) Fz$	0	$-F_y$	
6	0	$(1-\alpha)(1-\beta) Fz$	$\alpha(1-\beta)F_z$	$F_y$	
7	$\alpha(1-\beta)F_z$	$(1-\alpha)(1-\beta) Fz$	0	$-F_y$	
8	0	$F_z$	0		$F_B$

$$F_z = 4Q_0 - m + g$$

$$\beta = 0,3$$

$$\alpha = 0,2 \left( \frac{1700}{2b_g} \right)$$

$$F_y = 0,4 \times 0,5(F_z + m + g)$$

▼ **B**

**Static Tests With Normal In-Service Loads— Three Axle Bogies**

Figure J4

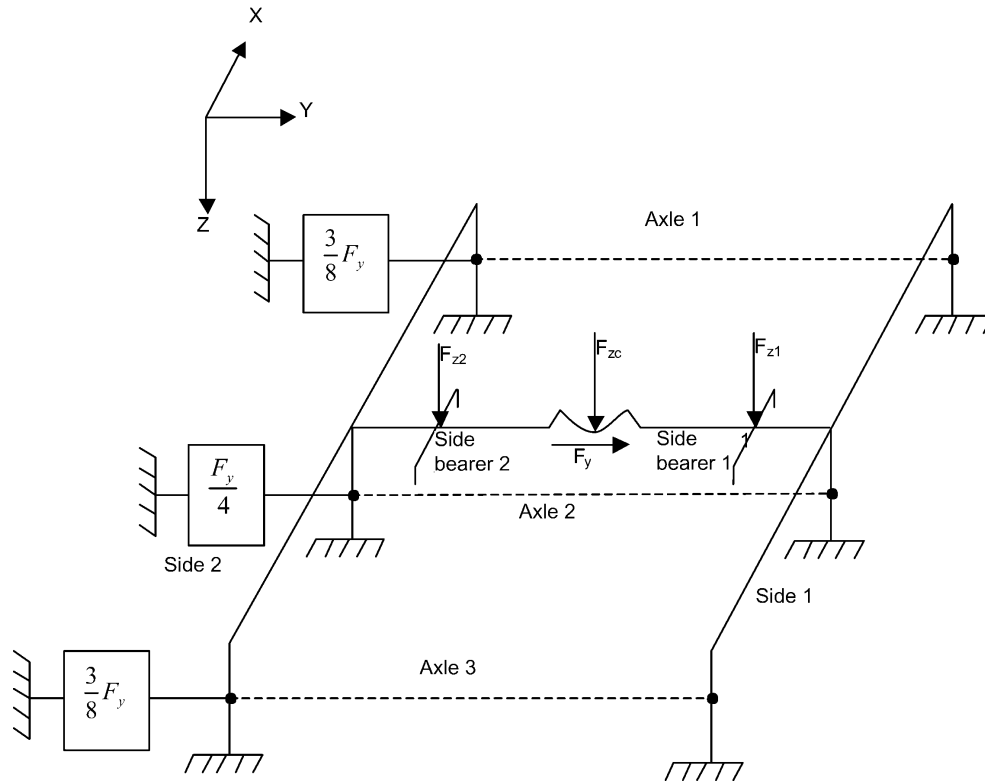

Table J8

Load Case	Loads				Braking Forces
	Vertical			Transverse	
	Friction Pad 2 $F_{z2}$	Pivot Bearing $F_{zc}$	Friction Pad 1 $F_{z1}$	$F_y$	
1	0	$F_z$	0		
2	0	$(1+\beta) F_z$	0		
3	0	$(1-\beta) F_z$	0		
4	0	$(1-\alpha)(1+\beta)F_z$	$\alpha(1+\beta) F_z$	$F_y$	
5	$\alpha(1+\beta) F_z$	$(1-\alpha)(1+\beta)F_z$	0	$-F_y$	
6	0	$(1-\alpha)(1-\beta)F_z$	$\alpha(1-\beta) F_z$	$F_y$	
7	$\alpha(1-\beta) F_z$	$(1-\alpha)(1-\beta)F_z$	0	$-F_y$	
8	0	$F_z$	0		$F_B$

$$F_z = 6Q_o - m + g$$

$$\beta = 0,3$$

$$\alpha = 0,2 \left( \frac{1700}{2b_g} \right)$$

$$F_y = 0,53 \times 0,5(F_z + m + g)$$

**▼B****J.3. FATIGUE TESTS****Definitions of applied loads**

The applied loads consist of:

- vertical loads on the pivot bearing and friction pads
- a transverse load
- loads due to braking
- torsional loads

**Vertical Loads And Loads Due To Roll**

— The vertical loads on the pivot bearing and friction pads shall be calculated by reference to the nominal bogie load. They depend on:

- $F_z$ , the static load exerted by the wagon body on each bogie
- $\alpha$ , the roll coefficient = 0,2
- $\beta$ , the bounce coefficient = 0,3

$F_z$  is a static load. The loads due to the coefficient  $\alpha$  are considered to be 'quasi static'. The loads due to the coefficient  $\beta$  are considered to be 'dynamic'.

The roll coefficient  $\alpha$  is taken to be equal to 0,2 for a spacing between the friction pads of 1 700 mm (standard two-axle bogies). If the spacing between the friction pads ( $2b_g$ ) differs from 1 700 mm, the value for  $\alpha$  shall be:

$$\alpha = 0,2 \left( \frac{1700}{2b_g} \right)$$

**Transverse Loads**

The transverse loads consist of two components:

- Two-axle bogies:
  - quasi-static load:  $F_{yq} = 0,1(F_z + m^+ g)$
  - dynamic load:  $F_{yq} = 0,1(F_z + m^+ g)$
- Three-axle bogies:
  - quasi-static load:  $F_{yq} = 0,133(F_z + m^+ g)$
  - dynamic load:  $F_{yd} = 0,133(F_z + m^+ g)$

**Loads Due To Braking**

The loads due to braking correspond to 100 % of the forces resulting from emergency braking.

On the bogie under test, these loads due to braking result in the following loads being applied:

- deceleration loads,
- contact loads,
- loads applied to the brake linkages.

**Torsional Loads**

Track twist, referenced to the bogie wheelbase, shall be 5 %.

**Test Procedure**

The fatigue tests consist of alternating quasi-static and dynamic load sequences that represent running through right and left-hand curves.

If the static tests defined in Appendix B have shown that the track twist induced stresses only in limited zones of the bogie frame, where the stresses caused by the vertical and transverse loads are minor, the fatigue test, as a first stage, shall be performed with only vertical and transverse loads.

In this case, the vertical and transverse quasi-static and dynamic loads shall vary with time as shown in the diagrams in Figures 3, 5, 6 and 7 (for two-axle bogies) or in Figures 5, 6, 7 and 8 (for three-axle bogies).

**▼ B**

In each sequence corresponding to a curve to the right or to the left, the number of dynamic cycles, vertically and transversely, shall be 20.

The dynamic variations of the vertical and transverse loads shall be of the same frequency and shall be in phase, as shown in the diagrams. The number of sequences simulating right hand curves and left hand curves in the test shall be the same.

In this first test stage, the number of cycles of dynamic load variations shall be  $6 \times 10^6$ .

The second test stage shall consist of  $2 \times 10^6$  cycles, with the static forces unchanged and the quasi-static and dynamic forces multiplied by 1,2.

The third test stage shall also consist of  $2 \times 10^6$  cycles and is performed as the second stage, but with the factor 1,2 replaced by 1,4.

Tests with application of loads corresponding to the loads due to braking shall be carried out if the results of the tests according to section 2 show them to be necessary (elastic limit exceeded during those tests).

**Torsional Loads**

A total of  $10^6$  alternating torsional load cycles shall be applied in all:

—  $6 \times 10^5$  during the first test stage

—  $2 \times 10^5$  during each of the other two stages

When specifying the torsional tests, the results of the static tests and the capabilities of the existing test facilities shall be taken into account.

If the static tests have shown that the bogie frame is not affected by track twist, it shall not be taken into account.

If the static tests in Appendix B show that the effects of the track twist loads are clearly different from those resulting from the vertical and transverse forces (e.g. because the stresses occur in different zones), the  $6 \times 10^5$  plus twice  $2 \times 10^5$  cycles of torsional loading can be applied separately from the vertical and transverse loads. Otherwise, the test setup shall be adapted in order to apply the vertical, transverse and track twist loads simultaneously.

The loads that simulate the effect of track twist shall correspond to those that occur when the suspension is functioning with damping.

**Results To Be Obtained**

No cracks shall be found after application of the  $6 \times 10^6$  cycles of the first test stage. This shall be confirmed by non-destructive inspection (magnetic particle or dye penetration test) after every  $1 \times 10^6$  cycles.

At the end of the second test stage, only the occurrence of small cracks, that would not require immediate repairs if they occurred in service, shall be acceptable.

The evolution of the stresses at the locations of highest stress found during the static test (paragraph 6.1.1.2.1.3) shall be monitored by means of strain gauges during the fatigue test, and in particular where stresses exceeding the stress limit have been tolerated in accordance with paragraph 6.1.1.2.1.3

**Fatigue Tests on Two-Axle Bogies**

Refer to figure J3.

**▼ B**

**Load On Pivot Bearing**

Figure J5

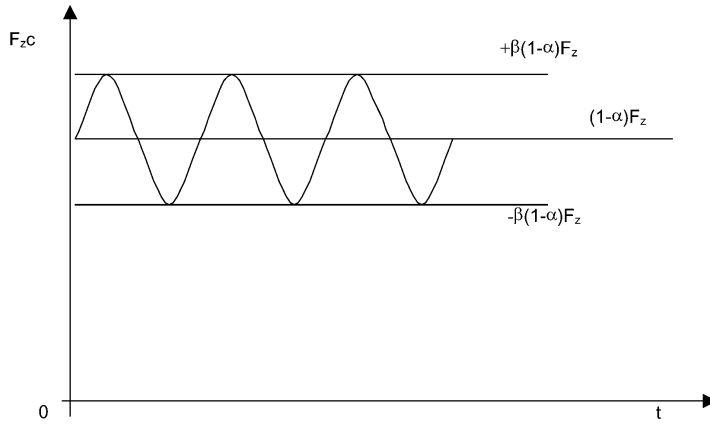

$$\left\{ \begin{array}{l} F_z = 4Q_0 - m + g \\ \alpha = 0,2 \left( \frac{1700}{2b_g} \right) \\ \beta = 0,3 \\ F_{zc} = (1 - \alpha) F \pm \beta(1 - \alpha) F_z \end{array} \right.$$

**Loads On Friction Pads**

Figure J6

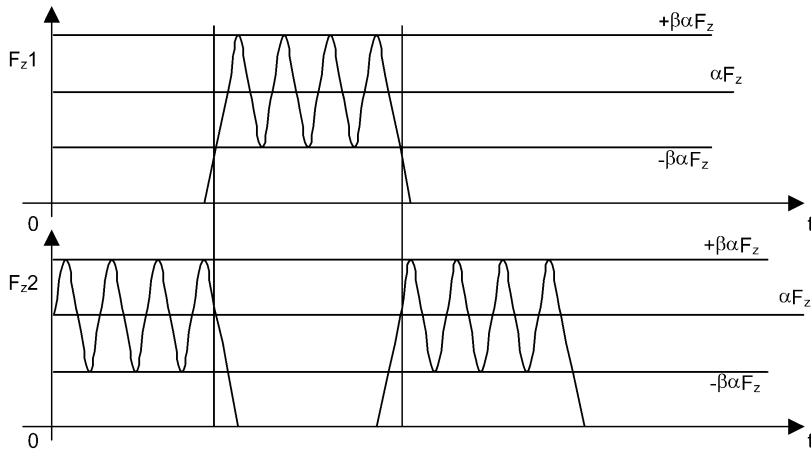

$$\begin{cases} F_{z1} = \alpha F_z \pm \beta \alpha F_z \\ F_{z2} = \alpha F_z \pm \beta \alpha F_z \end{cases}$$

**▼ B**

**Transverse load acting on the pivot bearing**

Figure J7

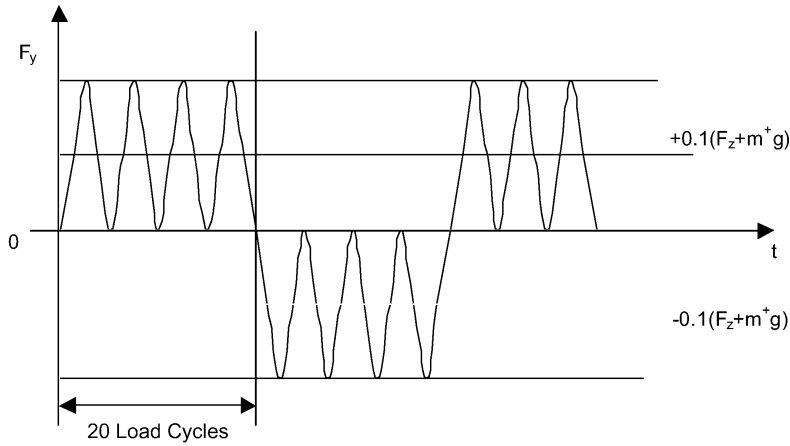

$$\{F_y = \pm [0,1(F_z \pm m^+ g) \pm 0,1(F_z + m^+ g)]\}$$

**Fatigue Tests — Three Axle Bogies**

Figure J8

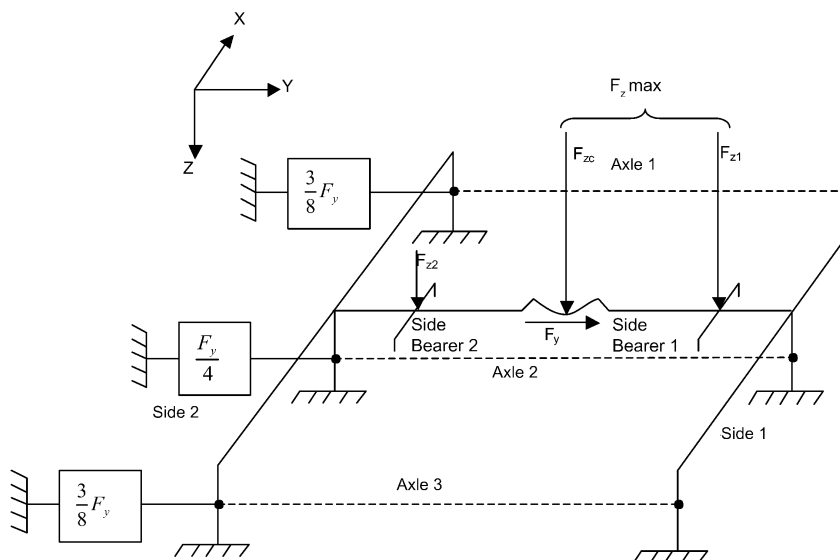

**Load on Pivot Bearing**

Refer to fig. J5.

$$\left\{ \begin{array}{l} F_z = 6Q_0 - m^+ g \\ a = 0,2 \left( \frac{1700}{2b_g} \right) \\ \beta = 0,3 \\ F_{zc} = (1 - a) F \pm \beta (1 - a) F_z \end{array} \right.$$

**Loads on Friction Pads**

Refer to figure J6.

**▼ B**

$$\begin{cases} F_{z1} = \alpha F_z \pm \beta \alpha F_z \\ F_{z2} = \alpha F_z \pm \beta \alpha F_z \end{cases}$$

**Transverse Load Acting on the Pivot Bearing**

Refer to figure J7

$$F_y = \pm [0,133(F_z + m^+g) + 0,133(F_z + m^+g)]$$

**J.4. NOTATION**

$Q_0$  = Static vertical force at the level of the wheel for a loaded wagon (kN)

$m^+$  = Bogie mass (t)

$F_z$  = Static vertical force acting on a bogie for a loaded wagon (kN)

$F_z = 4Q_0 - m^+g$  (for 2-axle bogies)

$F_z = 6Q_0 - m^+g$  (for 3-axle bogies)

$g$  = Acceleration due to gravity (9,8 m/s<sup>2</sup>)

$F_y$  = Transverse force (kN)

$F_B$  = Braking forces (kN)

$g^+$  = Track twist to be applied to the bogie axles ( ‰)

$\alpha$  = Coefficient corresponding to the effect of roll

The coefficient is a function of the spacing  $2b_g$

$\beta$  = Coefficient corresponding to the effect of bounce

$2b_g$  = Friction pad spacing (mm)

**J.5. OVERVIEW/GUIDELINES**

The tests can be divided into three groups:

— Static tests with exceptional in-service loads

These tests verify that there is no risk of permanent and visible deformation of the bogie frame due to the superposition of the maximum loads that can occur in service.

— Static tests to simulate normal in-service dynamic loads

These tests verify that there is no risk of fatigue cracks occurring due to the superposition of in-service loads.

— Fatigue tests

The purpose of these tests is to determine the service life of the bogie frame, to detect potential hidden weak spots — in particular at locations where it is not possible to attach strain gauges, — and to assess the safety margin.

**Common Conditions For Rig Tests**

The tests shall be performed using a test set-up that allows the application and distribution of the loads exactly at the same locations where they occur in service, while at the same time correctly simulating the play and the degrees of freedom associated with the suspension and the elements connecting the bogie to the body.

The tests can be performed with or without the suspension.

The suspension damping devices shall be de-activated so as to prevent friction.

The constructional characteristics of the bogie shall be taken into account when determining the manner in which the loads and the resulting reaction forces are applied to the bogie frame. The sketch below shows an example of the application of the loads on 2-axle bogies.

The loads to be applied are detailed in Appendices A, B and C.



ANNEX K

VEHICLE TRACK INTERACTION AND GAUGING

Wheelset

- K.1 ASSEMBLY OF COMPONENTS
  - K.1.1 General
  - K.1.2 Interference between axle wheelset and wheel bore hub
  - K.1.3 Press fitting diagram
- K.2 WHEELSET CHARACTERISTICS
  - K.2.1 Mechanical resistance of the assemblies
- K.3 DIMENSIONS AND TOLERANCES
  - K.3.1 General
  - K.3.2 Characteristics of mounted wheels
  - K.3.3 Overhang of the wheel
- K.4 PROTECTION AGAINST CORROSION

K.1 ASSEMBLY OF COMPONENTS.

K.1.1 **General.**

Before fitting, all elements which comprise the wheelset, shall comply with the geometric requirements of the documents which define them. The wheels and axle shall be ready to assemble.

It is permissible to either shrink-fit or press-fit the wheelset elements. Wheelset journal bearings shall fitted onto the wheelset according to the manufacturer's instructions.

The static imbalance of the two wheels of each wheelset shall be in the same diametrical plane and on the same side of the axle.

K.1.2 **Interference between axle wheelset and wheel bore hub.**

Where no specific interference fit has been specified, the interference 'j' in mm shall be:

- shrink fit:  $0,0009 \, dm \leq j \leq 0,0015 \, dm$
- press fit:  $0,0010 \, dm \leq j \leq 0,0015 \, dm + 0,06$

where  $dm$  is the mean diameter of the wheelset in mm.

K.1.3 **Press fitting diagram.**

For press fitting, a force-displacement curve gives confidence that the fitted surfaces are not damaged and that the specified interference has been achieved.

The range of the end fitting force, depends on the force  $F$  defined in K.2.1 and shall be:

$$0,85 \, F < \text{end fitting force} < 1,45 \, F$$

K.2 WHEELSET CHARACTERISTICS.

K.2.1 **Mechanical resistance of the assemblies.**

Wheelsets shall be tested to prove correct wheel fitment using a press incorporating a force-recording device. A proving thrust  $F$  shall be gradually and uniformly applied around the wheel and sustained for a period of 30 seconds. Unless otherwise specified by the designer, the value of the force  $F$  shall be:

$$F = 4 \times 10^{-3} \, dm \, \text{MN}$$

where  $0,8 \, dm < L < 1,1 \, dm$



**▼B**

and  $dm$  is the mean diameter of the wheel seat (mm);  $L$  is the length of the wheel hub (mm).

Results to be achieved.

There shall be no displacement of the wheel relative to the axle after the application of the proving thrust.

### K.3 DIMENSIONS AND TOLERANCES.

#### K.3.1 General.

The dimensions of the wheelset shall be in accordance with the design drawings. The dimensional and geometrical tolerances to be applied in the assembly of the different component parts on the wheelset are given in the following subclauses.

Measurements shall be made without any load on the wheelset.

#### K.3.2 Characteristics of mounted wheels.

Fig. K6

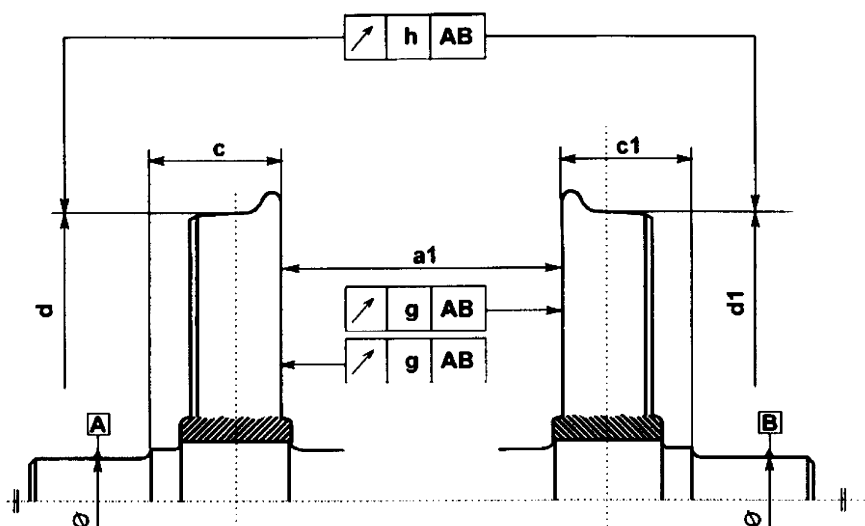

Table K18

Description	Symbol	Tolerance (mm)	
		≤ 120km/h	> 120km/h
Distance between internal wheel faces <sup>(1)</sup> (Back-to-Back Distance)	$a_1$	+ 2 <sup>(2)</sup> 0	
Distance between the Flange Back and the plane showing, on the journal side, the corresponding bearing collar	$c - c_1$ or $c_1 - c$	≤ 1	
Difference in tread circle diameter.	$d - d_1$ or $d_1 - d$	≤ 0,5	≤ 0,3
Radial deviation at the tread	$h$	≤ 0,5	≤ 0,3
Axial deviation of the Flange Backs <sup>(1)</sup>	$g$	≤ 0,8	≤ 0,5

<sup>(1)</sup> Measured 60 mm below the top of the flange.

<sup>(2)</sup> Tolerances may be changed for special design wheelsets.

**▼B****K.3.3 Overhang of the wheel.**

The lengths of the wheelseat and the wheel hub shall be selected so that the hub slightly overlaps the wheelseat, especially on the axle body side. The overlap length shall be between 2 and 7 mm.

**K.4 PROTECTION AGAINST CORROSION.**

Wheelsets components shall be protected according to the requirements of their design specification.

It is permissible for cavities arising from the overhang of the wheel hub on the wheelseat to be filled with an anticorrosion product.

*ANNEX L***VEHICLE TRACK INTERACTION AND GAUGING****Wheels**

- L.1. Design assessment
  - L.1.1. General
    - L.1.2. Design parameters to be assessed.
      - L.1.2.1. Parameters for geometrical compatibility
        - L.1.2.2. Parameters for thermo mechanical Compatibility
        - L.1.2.3. Parameters for mechanical assessment
      - L.1.3. Assessment of geometrical Compatibility
      - L.1.4. Assessment of thermo mechanical compatibility
        - L.1.4.1. General procedure
          - L.1.4.2. First step: Braking bench test
            - L.1.4.2.1. Test procedure
            - L.1.4.2.2. Decision criteria
          - L.1.4.3. Second step: Wheel fracture bench test
            - L.1.4.3.1. General
            - L.1.4.3.2. Wheel fracture bench test procedure
            - L.1.4.3.3. Decision criteria
          - L.1.4.4. Third step: Field braking test
            - L.1.4.4.1. General
            - L.1.4.4.2. Test procedure
            - L.1.4.4.3. Decision criteria
        - L.1.5. Assessment of mechanical compatibility
          - L.1.5.1. General procedure
          - L.1.5.2. First step: calculation
            - L.1.5.2.1. Applied forces
            - L.1.5.2.2. Calculation procedure
            - L.1.5.2.3. Decision criteria
          - L.1.5.3. Second step: Bench test
            - L.1.5.3.1. General.
            - L.1.5.3.2. Definitions of the bench loading and test procedure
            - L.1.5.3.3. Decision criteria
  - L.2. PRODUCT ASSESSMENT
    - L.2.1. Mechanical characteristics linked to wear:
      - L.2.1.1. Tensile test characteristics
      - L.2.1.2. Hardness characteristics in the rim
      - L.2.1.3. Heat treatment homogeneity
    - L.2.2. Mechanical characteristics linked to safety:
      - L.2.2.1. Impact test characteristics
      - L.2.2.2. Toughness characteristic of the rim
    - L.2.3. Material cleanliness
      - L.2.3.1. Micrographic cleanliness
      - L.2.3.2. Internal integrity
    - L.2.4. Surface condition
      - L.2.4.1. Characteristics to be achieved
    - L.2.5. Surface integrity

**▼B**

- L.2.6 Geometrical tolerances
- L.2.7 Static imbalance
- L.2.8 Protection against corrosion

**▼B**

## L.1 DESIGN ASSESSMENT

L.1.1 **General**

This chapter describes the assessment methods for wheel design in order to meet the performance requirements. There are three main aspects of a wheel's performance, each of which has different aims:

- Geometrical
  - to ensure compatibility with the track
  - to ensure compatibility with the axle
- Thermo mechanical:
  - to manage wheel deformation
  - to ensure that braking does not induce broken wheels
- Mechanical:
  - to ensure compatibility with the intended axle load
  - to ensure that wheels do not fail due to fatigue

L.1.2 **Design parameters to be assessed.**L.1.2.1 *Parameters for geometrical compatibility*

There are three sets of parameters that are linked to functional, assembly or maintenance purposes.

- Functional purposes
  - Nominal tread diameter: it affects buffer height and the loading gauge.
  - Rim width: it interfaces with Switches and Crossings.
  - Cone angle of the tread: it influences the stability of the vehicle
  - Tread profile outside of conical part of the tread
  - Flange height, thickness and angle
  - Transition between the flange and the active part of the tread
  - Rim position with reference to the wheel seat position on the axle
  - Parallelism of bore diameter
- Assembly purposes
  - Bore diameter
  - Hub length in order to ensure an adequate overhang of the wheel hub on the axle wheel seat.
- Maintenance purposes
  - Wear limit diameter of the tread
  - Wear groove shape
  - Geometry of the area for wheel clamping on reprofiling machines
  - Position of the hole for oil injection of dismantling
  - General rim shape in order to allow ultrasonic residual stress measurement for tread braked wheels.

L.1.2.2 *Parameters for thermo mechanical Compatibility*

Wheels shall be capable of absorbing the heat energy that is dissipated during

**▼ B**

service. This amount of energy generated is dependent upon:

- The energy created by the friction of the brake blocks on the tread.
- Type of brake blocks (nature, dimensions and number)

#### L.1.2.3 *Parameters for mechanical assessment*

- Maximum axle load of wheelset
- Nature of the duty cycle
  - description of the lines: geometrical quality of track, curve parameters, maximum speed...
  - proportion of time travelling on these differing lines
- Distance travelled during the whole life of the wheel

#### L.1.3 **Assessment of geometrical Compatibility**

The drawing of the wheel shall be in conformity with the requirements that are defined according to the paragraph above: parameters for geometrical compatibility.

#### L.1.4 **Assessment of thermo mechanical compatibility**

##### L.1.4.1 *General procedure*

All new designs of wheels shall be fully assessed using methods that are appropriate to the application to demonstrate that they satisfy the requirements set out in this Annex.

This assessment shall be composed of three steps. If step 1 is passed, no further assessment is necessary. If step 1 is failed, step 2 shall be applied. If step 2 is passed, no further assessment is necessary. Step 3 assesses a marginal failure of steps 1 and 2. If step 3, is failed the wheel shall be considered to be non-compliant. For each step, tests shall be made on a wheel with a new rim (tread at its nominal diameter) and on a wheel with a worn rim (tread at its wear limit diameter).

In each case, the wheel selected for test shall have the worst case rim geometry for thermo mechanical behaviour; a validated numerical simulation shall confirm the selection. Where it is not possible to test the worst case wheel, the results shall be extrapolated to the worst case by the same numerical simulation.

##### L.1.4.2 *First step: Braking bench test.*

###### L.1.4.2.1 *Test procedure.*

The power to be applied for 45 minutes during this test shall be equal to  $1,2P_a$ .

$$P_a = m \cdot g \cdot V_a \cdot \text{pente} + m \cdot \gamma \cdot v_a$$

where

- $m$  = vehicle mass on rail per wheel (kg)
- $g$  = gravitational acceleration ( $\text{m/s}^2$ )
- $\text{slope}$  = average slope of the line (slope in ‰/1 000)
- $\gamma$  = deceleration of the train ( $\text{m/s}^2$ )
- $V_a$  = vehicle velocity (m/s)

**▼ M1**

When monobloc wheels are fitted to wagons that are 100 % tread braked, the following parameters should be taken into account:

Wheel diameter range (in mm)	1 000 to 920 and 920 to 840	840 to 760	760 to 680
Power	50 kW	42,5 kW	38 kW

**▼M1**

Wheel diameter range (in mm)	1 000 to 920 and 920 to 840	840 to 760	760 to 680
Application time	45 min	45 min	45 min
Running speed	60 km/h	60 km/h	60 km/h

*Note:* For specific types of freight traffic, the values for power and/or application time and/or running speed and/or axle loads and/or wheel diameters can be modified to check on the thermo-mechanical behaviour of these wheels in the context of a limited utilisation.

**▼B**

## L.1.4.2.2 Decision criteria.

Three criteria shall be satisfied simultaneously for the new wheel and for the worn wheel.

For the new wheel:

1. maximum lateral displacement of the rim during braking + 3/-1 mm
2. residual stresses in the rim after cooling:
  - $\sigma_m \leq + \sum_r N/mm^2$  as an average over three measurements
  - $\sigma_{in} \leq + (\sum_r + 50) N/mm^2$  for each measurement
3. maximum lateral displacement of the rim after cooling + 1,5/-0,5 mm.

Lateral displacement is considered to be positive when the distance between the flange backs increases.

For the worn wheel:

1. maximum lateral displacement of the rim during braking + 3/-1mm
2. residual stresses in the rim after cooling:
  - $\sigma_{rw} \leq + (\sum_r + 75) N/mm^2$  as an average over three measurements
  - $\sigma_{iw} \leq + (\sum_r + 100) N/mm^2$  for each measurement
3. maximum lateral displacement of the rim after cooling + 1,5/-0,5mm

The value of  $\sum_r$  shall be determined according to the steel grade requirements of the wheel rim. For ER6 and ER7 grades of EN13262,  $\sum_r = 200N/mm^2$ .

For other steel grades, another value for  $\sum_r$  shall be agreed.

## L.1.4.3 Second step: Wheel fracture bench test.

## L.1.4.3.1 General.

This second step shall be take place if the residual stresses measured in the first step are above the decision criteria.

## L.1.4.3.2 Wheel fracture bench test procedure

The test procedure for the wheel fracture bench test shall comply with Annex A.3 of EN13979-1.

## L.1.4.3.3 Decision criteria.

The tested wheel shall remain unfractured.

## L.1.4.4 Third step: Field braking test.

## L.1.4.4.1 General.

This third step shall take place if one result of the first step is above a decision criterion and if the wheel is not rejected after the second step.

## L.1.4.4.2 Test procedure.

The power to be applied during this test shall be as defined in Step 1 of this assessment.

**▼ B****L.1.4.4.3 Decision criteria.**

Three criteria shall be satisfied simultaneously for the new wheel and for the worn wheel.

For the new wheel:

1. maximum lateral displacement of the rim during braking + 3/-1mm.
2. residual stresses in the rim after cooling:
  - $\sigma_m \leq + (\sum_r - 50) \text{ N/mm}^2$  as an average over three measurements
  - $\sigma_{in} \leq + \sum_r \text{ N/mm}^2$  for each measurement
3. maximum lateral displacement of the rim after cooling + 1,5/-0,5mm.

For the worn wheel:

1. maximum lateral displacement of the rim during braking + 3/-1mm
2. residual stresses in the rim after cooling:
  - $\sigma_{rw} \leq + \sum_r \text{ N/mm}^2$  as an average over three measurements
  - $\sigma_{iw} \leq + (\sum_r + 50) \text{ N/mm}^2$  for each measurement
3. maximum lateral displacement of the rim after cooling + 1,5/-0,5mm

The value of  $\sum_r$  shall be fixed according to steel grade requirements of the wheel rim.

For ER6 and ER7 grades of EN13262,  $\sum_r = 200 \text{ N/mm}^2$ .

For other steel grades, another value for  $\sum_r$  shall be agreed.

**L.1.5 Assessment of mechanical compatibility****L.1.5.1 General procedure.**

This assessment shall be composed of two steps. If step 1 is passed no further assessment is necessary. If step 1 is failed step 2 shall be applied. If step 2 is failed the wheel shall be considered to be non-compliant. The purpose of this assessment is to verify that no fatigue cracks initiate in the web during the whole life of the wheel.

The worst case wheel geometry for mechanical behaviour shall be assessed. Where the bench test wheel is not the worst case, test parameters shall be extrapolated to the worst case by a validated numerical simulation.

**L.1.5.2 First step: calculation.****L.1.5.2.1 Applied forces.**

The forces to be applied shall use the force P as a basis.

P is half the vertical force per wheelset on rail.

Three load cases shall be considered (see fig. L1):

— Case 1: straight track

$$F_z = 1,25P$$

$$F_{y1} = 0$$

— Case 2: full curves

$$F_z = 1,25P$$

$$F_{y2} = 0,6P \text{ P for non-guiding wheelsets}$$

$$F_{y2} = 0,7P \text{ P for guiding wheelsets}$$

— Case 3: negotiation of points and crossings

$$F_z = 1,25P$$



**▼B**

For non-guiding wheelsets

$$F_{y2} = 0,36P \quad F_{y3} = 0,6$$

For guiding wheelsets

$$F_{y2} = 0,42P \quad F_{y3} = 0,6$$

Figure. L1

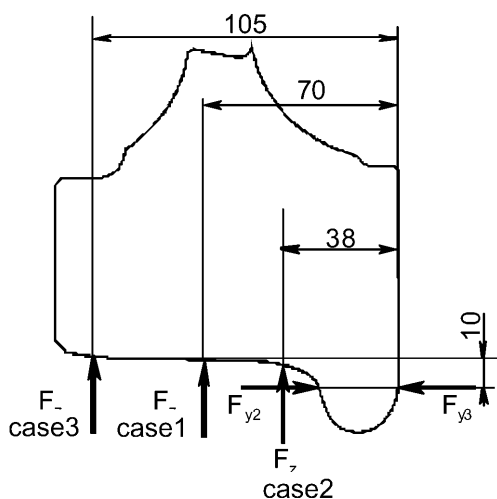

#### L.1.5.2.2 Calculation procedure.

A validated finite element analysis program shall be used to calculate the stresses in the wheel.

#### L.1.5.2.3 Decision criteria.

The range of the dynamic stresses  $\Delta\sigma$  shall be lower than the permissible stresses at all points on the web.

The permissible range of dynamic stresses, A, are as follows:

- for wheels with a machined web,  $A = 360 \text{ N/mm}^2$
- for wheels with a non-machined web,  $A = 290 \text{ N/mm}^2$

#### L.1.5.3 Second step: Bench test.

##### L.1.5.3.1 General.

This second step shall be used if the result of the first step is above a decision criterion.

##### L.1.5.3.2 Definitions of the bench loading and test procedure.

They shall be agreed between the designer of the wheel and the Notified Body.

##### L.1.5.3.3 Decision criteria.

Four wheels shall be tested.

No fatigue cracks  $\geq 1\text{mm}$  shall exist after the test.

## L.2 PRODUCT ASSESSMENT

### L.2.1 Mechanical characteristics linked to wear:

#### L.2.1.1 Tensile test characteristics

Rim and web characteristics shall be as listed in table L1.



**▼B**

Table L3

Steel Grade	Minimum Brinell hardness value
ER6	225
ER7	235
ER8	245

L.2.1.3 *Heat treatment homogeneity*

The hardness values measured on the rim shall be contained within a range of 30 HB.

L.2.2 **Mechanical characteristics linked to safety:**L.2.2.1 *Impact test characteristics*

Two sets of impact tests shall be carried out; one set with test specimens at + 20 °C, one set with test specimens at -20 °C. In each set of tests, three specimens shall be tested (marked as specimen 3 in Figure L.2). Table 4 gives the values to be achieved. The marking of the impact test samples shall enable identification of the longitudinal surfaces that are parallel to section A-A. The test pieces shall be prepared in accordance with EN 10045-1. The axis of the bottom of the notch shall be parallel to the section A-A in figure L1. At + 20 °C, U notch specimens shall be used. At - 20 °C, V notch specimens shall be used.

Table L4

Steel Grade	KU (in joules) at + 20 °C		KV (in joules) at -20 °C	
	Average	Minimum	Average	Minimum
ER6	17	12	12	8
ER7	17	12	10	7
ER8	17	12	10	5

L.2.2.2 **Toughness characteristic of the rim**

This characteristic need only be verified on tread braked wheels (service brake or parking brake). Table L6 gives the minimum values to be achieved.

Table L6

Steel Grade	Average (over 6 test pieces)	Single test piece minimum
	N/mm <sup>2</sup> √m	N/mm <sup>2</sup> √m
ER6	100	80
ER7	80	70
ER8	70	60

L.2.3 **Material cleanliness**L.2.3.1 *Micrographic cleanliness*

Material cleanliness shall be measured by micrographic examination (ISO 4967 method A). The location from which the samples shall be taken is shown in figure L3.

▼ B

Figure L. 3

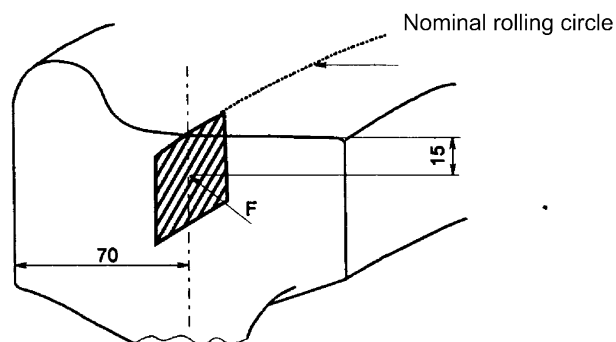

Values to be achieved are given in table L6.

Table L6

Type of inclusions	Thick series (maximum)	Thin series (maximum)
A (Sulphides)	1,5	2
B (Aluminates)	1,5	2
C (Silicates)	1,5	2
D (Globular Oxides)	1,5	2
B + C + D	3	4

L.2.3.2 *Internal integrity*

Internal integrity of all wheels shall be determined by an automatic ultrasonic examination. Standard defects are flat bottom holes with different diameters.

The rim shall have no internal defects that give echo magnitudes higher than or equal to those obtained for a standard defect, situated at the same depth. The diameter of this standard defect is 3 mm.

There shall be no attenuation of the back echo higher than 4dB during axial examination.

L.2.4 **Surface condition**L.2.4.1 *Characteristics to be achieved.*

According to their use, wheels may be fully or part machined. Their surface shall not show any marks other than those stipulated in here.

The parts which remain as non machined shall be shot-blasted for  $R_a < 25 \mu\text{m}$ , perfectly dressed and smoothly blended into the machined areas.

The average surface roughness ( $R_a$ ) of 'finished' or 'ready for assembly' wheels is given in table L8.

Table L8

Area of the wheel	State of Delivery	Roughness $R_a$ ( $\mu\text{m}$ )
Bore	Finished	$\leq 12,5$
	Ready for assembly <sup>(1)</sup>	0,8 to 3,2

**▼B**

Area of the wheel	State of Delivery	Roughness $R_a$ ( $\mu\text{m}$ )
Web and hub	Finished <sup>(2)</sup>	$\leq 12,5$
Rim Tread	Finished	$\leq 12,5$ <sup>(3)</sup>
Rim Faces	Finished	$\leq 12,5$ <sup>(3)</sup>

<sup>(1)</sup> If the wheel is to be fitted on a hollow axle, other values may be required for the purpose of the in-service ultrasonic inspection.

<sup>(2)</sup> If so defined, this area of the wheel may remain unmachined, provided the tolerances indicated in this table are achieved.

<sup>(3)</sup>  $\leq 6,3$  if required for a standard defect of 2mm.

**L.2.5 Surface integrity**

Surface integrity of the web shall be confirmed by a magnetic particle test or an alternative process having at least equivalent sensitivity. The limit defect shall be equal to 2mm in the case of a machined web.

**L.2.6 Geometrical tolerances**

The geometry and dimensions of wheels shall be defined by a drawing. The geometrical tolerances shall comply with those in table L9. The symbols used are shown in figure. L4.

▼ B

Figure L4  
Symbols

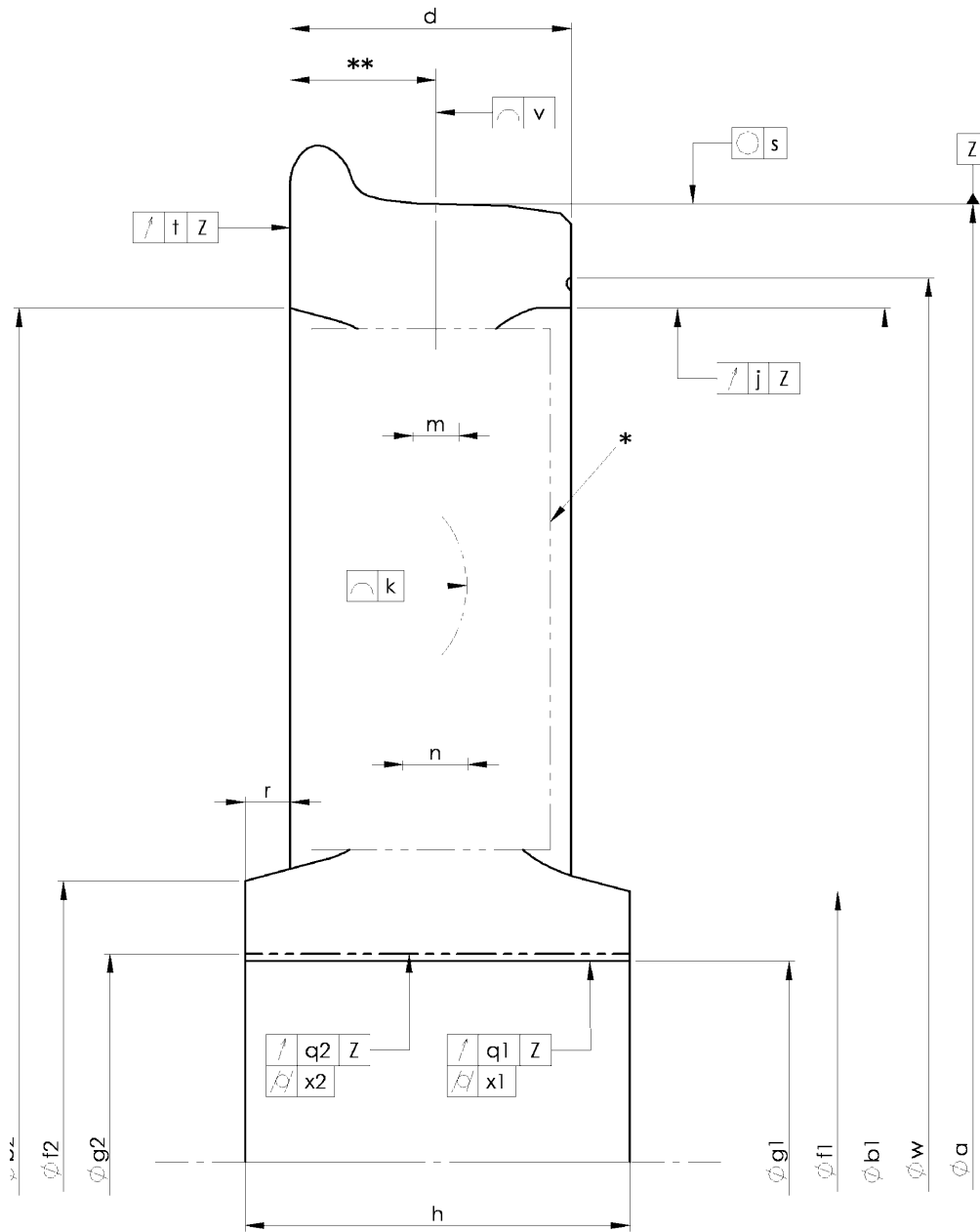

\*\* Dimension defined by drawing

\* This area shall be defined to meet the requirements of an Interoperability Constituent.



Table L9

Tolerances (mm)					
Designation		Symbols (see fig L4)		Values	
		Dimensions	Geometrical <sup>(1)</sup>	Unmachined	Machined
Rim	External diameter	a			0/+4
	Internal diameter (outer)	b <sub>1</sub>			0/-4
	Internal diameter (inner)	b <sub>2</sub>		0/-6	0/-4
	Width	d			± 1
	Tread profile <sup>(3)</sup>		v		≤ 0,5
	Circularity of the tread		s		≤ 0,2
	Total run out in axial direction		t		≤ 0,3
	Total run out in radial direction of the jaw hold		j		≤ 0,2
	External diameter of the groove (i.e. wear line)	w			0/+2
Hub	External diameter (outer)	f <sub>1</sub>		0/+10	0/+5
	External diameter (inner)	t <sub>2</sub>		0/+10	0/+5
	Internal diameter of the bore:				
	‘finished’	g <sub>1</sub>			0/-2
	‘finished ready’ for assembly	g <sub>2</sub>		See Annex K or in accordance with the drawing	
	Cylindricity of internal diameter of the bore:				
	‘finished’		x <sub>1</sub>		≤ 0,2
	‘finished ready for assembly’		x <sub>2</sub>		≤ 0,02 <sup>(2)</sup>
	Length	h			0/+2
	Hub to wheel overhang	r			0/+2
	Total run out of the diameter of the bore:				
	‘finished’		q <sub>1</sub>		≤ 0,2
‘finished ready for assembly’		q <sub>2</sub>		≤ 0,1	
Web	Position for the web at the connection with the rim and the hub		k	≤ 8	≤ 8
	Thickness at the connection with the rim	m		+8/0	+5/0
	Thickness at the connection with the hub	n		+10/0	+5/0

<sup>(1)</sup> See ISO 1101

<sup>(2)</sup> Any slight taper within the permitted tolerance shall be such as the ‘larger’ diameter is at the axle-entry end of the bore on assembly.

<sup>(3)</sup> From the top of the flange as far as the external chamfer.

**▼B****L.2.7 Static imbalance**

The maximum static imbalance of a finished wheel in the delivery condition is defined in table L10.

The means and methods of measurement shall be defined between the customer and the supplier.

*Table L10*

For vehicles running at Speed $v$ km/h	Static imbalance g . m	Symbol
$v \leq 120$	$\leq 125$	E3
$120 < v \leq 200$	$\leq 75$	E2

**L.2.8 Protection against corrosion**

Protection shall be provided in accordance with the wheel design specification.





## ANNEX M

## VEHICLE TRACK INTERACTION AND GAUGING

## Axle

## M.1. DESIGN ASSESSMENT

## M.1.1. General

The following major phases for the definition of an axle are:

- a) Identification of the forces to be taken into account and calculation of the moments on the various sections of the axle.
- b) Selection of the diameters for axle-body and journals. On the basis of the selected diameters, calculation of the diameters for the other sections.
- c) The options taken shall be verified by:
  - Stress calculation for each section.
  - Comparison of the stresses with the maximum permissible stresses.

The permissible stresses are essentially defined by:

- The steel grade.
- Whether the axle is solid or hollow.

## M.1.2. Identification of forces and calculation of moments.

Two types of forces shall be addressed:

- Masses in motion.
- Braking.

## M.1.3. Geometrical and dimensional tolerances

M.1.3.1. *Selection of the diameters for journals and axle body.*

In selecting the diameters of the journals and axle body, reference shall be made initially to existing sizes of associated components e.g. bearings.

The selection of diameters shall be verified by comparing the calculated stresses with the maximum permissible stresses. A very shallow groove (0,1 to 0,2 mm) shall be provided, so that the end of the inner bearing ring does not cause any notch effect on the journal.

M.1.3.2. *Selection of the diameters of the various seats from the diameter of the axle body or of the journals.*

## M.1.3.2.1. Collar bearing surface.

In order to standardise whenever possible, the diameter of the collar bearing surface shall be 30 mm greater than that of the journal. The transition between the journal and the collar bearing surface shall be provided as illustrated in figure M3 (detail V).

## M.1.3.2.2. Transition between the collar bearing surface and wheel seat.

In order to standardise whenever possible, this transition shall have only one radius of 25 mm.

If this value cannot be met, the highest possible value shall be selected in order to minimise the stress concentration on this area.

## M.1.3.2.3. Wheel seat.

The ratio between the wheel seat and the axle body diameters shall be at least equal to 1,12 at the wheel seat wear limit. It is recommended that this ratio is at least 1,15 for an axle in new condition.

The transition between these two areas shall be provided in such a way that the stress concentration remains at the lowest possible level.

**▼B**

In order to have the lowest value of the stress concentration factor at the transition between axle body and wheelseat, the value of the biggest radius on the axle body side shall be at least 75mm.

**M.1.4. Maximum permissible stresses.**

The maximum permissible stresses shall be derived from:

- The fatigue limit in rotating bending for the various areas of the axle.
- The value of a factor of safety 'S' which varies with the steel grade.

**M.1.4.1. Steel grade EAIN**

The following values shall be used:

- For a solid axle:
  - 200 N/mm<sup>2</sup> without press-fit.
  - 120 N/mm<sup>2</sup> with press-fit.
- For a hollow axle:
  - 200 N/mm<sup>2</sup> without press-fit.
  - 110 N/mm<sup>2</sup> with press-fit (apart from journal).
  - 94 N/mm<sup>2</sup> with press-fit on the journal.
  - 80 N/mm<sup>2</sup> for the surface of the bore.

For solid and hollow axles, the value of security coefficient 'S', by which fatigue limits shall be divided to obtain the maximum permissible stresses is 1,2.

For hollow axles, these permissible stresses are applicable if the ratio of journal diameter to bore diameter is < 3 or the ratio of wheelseat diameter to bore diameter is < 4.

**M.1.4.2. Steel grades other than EAIN.**

The fatigue limit shall be determined for the following areas of the axle:

- The surface of the axle body.
- The bearing surface with an equal clamping condition at the wheelseats.

In the case of a hollow axle, the fatigue limit shall also be determined for the bearing surface with an equivalent bearing/axle interference condition.

- The surface of the bore.

The value of the factor of safety 'S' shall be determined with regard to the sensitivity of the steel grade to the notch effect.

**M.2. PRODUCT ASSESSMENT****M.2.1. Mechanical characteristics:****M.2.1.1. Characteristics from tensile test**

The values to be obtained at the mid-radius of solid axles or at the mid-distance between external and internal surfaces of hollow axles are given in table M1.

Table M1

$R_{eH}$ (N/mm <sup>2</sup> ) <sup>(1)</sup>	$R_m$ (N/mm <sup>2</sup> )	$A_5$ %
≥ 320	≥ 550	≥ 22

<sup>(1)</sup> If no distinctive yield strength is present, the proof stress  $R_{p0,2}$  shall be determined.

**▼B**

**M.2.1.2. Impact test characteristics**

Impact test characteristics shall be determined at 20 °C in the longitudinal and transverse direction. Three test samples shall be taken from adjacent positions from each test section. The test samples shall be taken from the locations indicated in fig M1. Values to be obtained at the mid-radius of solid axles, or at the mid-distance between external and internal surfaces of hollow axles, are given in table M1.

No individual values shall be lower than 70 % of the values in table M2.

Figure M1

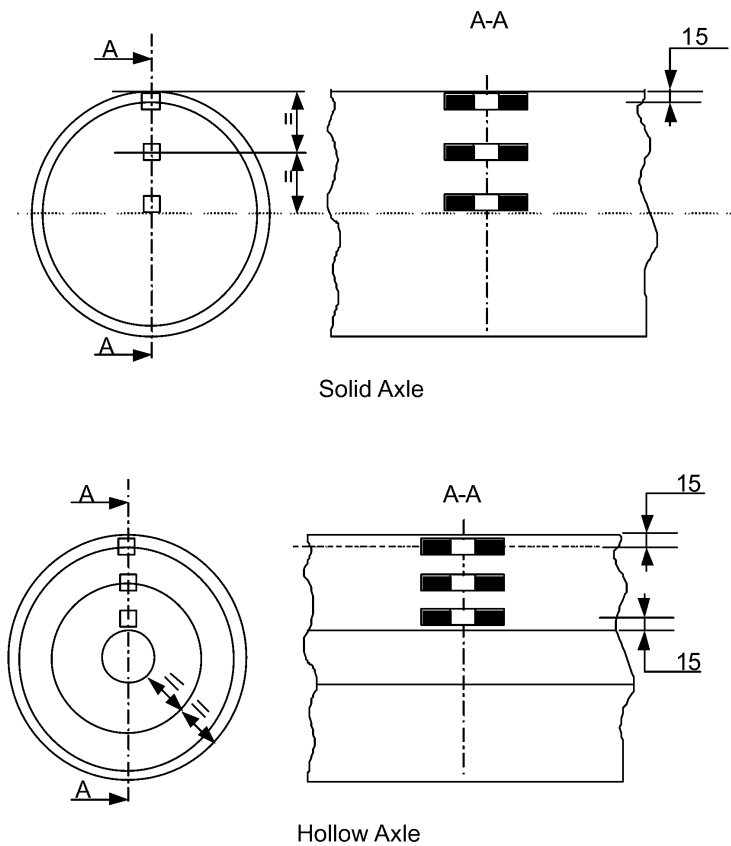

Solid Axle

Hollow Axle

Table M2

KU longitudinal (J)	KU transverse (J)
≥ 30	≥ 20

**M.2.2. Microstructure characteristics**

The microstructure shall be one of ferrite and pearlite. The grain size shall not be greater than those defined by the reference diagram of type V of ISO 643.

**M.2.3. Material micrographic cleanliness**

Material cleanliness shall be measured by micrographic examination (ISO 4967 method A). The location from which the samples shall be taken is shown in fig. M2. Maximum values of thick series inclusions to be obtained are given in table M3.

Table M3

Type of inclusions	Thick series (maximum)
A (Sulphides)	1,5

**▼B**

Type of inclusions	Thick series (maximum)	
B (Aluminates)	1,5	
C (Silicates)	1,5	
D (Globular oxides)	1,5	
B + C + D	3	

Figure M2

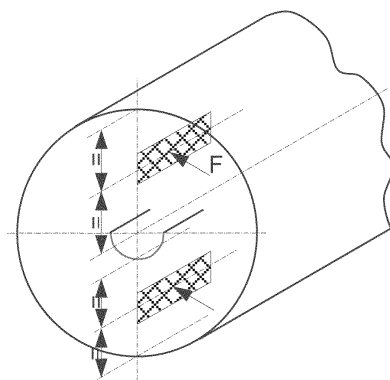
**M.2.4. Internal integrity**

Internal integrity shall be determined by ultrasonic examination.

Axles shall have no internal defects that give echo magnitudes higher than or equal to those obtained for a standard defect, situated at the same depth. For the purposes of this test, a standard defect shall be a 3mm diameter flat-bottomed hole.

There shall be no attenuation of the back echo higher than 4dB due to inclusions or internal defects.

**M.2.5. Permeability to ultrasound**

Axles shall be permeable to ultrasound. This shall be verified by a recorded ultrasound test for each axle.

The echo obtained on the axles under test shall have an amplitude higher than or equal to 50 % of full screen height, after preliminary calibration of the apparatus on a standard wedge. The height of the background noise level shall be lower than 10 % of full screen height.

**M.2.6. Surface characteristics****M.2.6.1. Surface finish**

The axle surface shall not show any marks other than those at the positions stipulated in this Annex.

Permissible surface roughness ( $R_a$ ) of finished or ready to assemble parts is given by table M4. Symbols are as shown in figure M3.

Table M4

Designation	Symbol	Surface roughness (!) $R_a$ ( $\mu\text{m}$ )	
		Rough – machined	Finished or Ready for Assembly
End of the axle			
Axle end and chamfer	a	—	6,3

▼ **B**

Designation	Symbol	Surface roughness <sup>(1)</sup> R <sub>a</sub> (µm)	
		Rough – machined	Finished or Ready for Assembly
Axle centre face (plain and hollow axle)	See details R1 and R2	—	3,2
Journal			
Journal diameter	b	12,5	0,8
Stress relieving grooves	c (detail V)		0,8
Abutment Abutment diameter	d	12,5	1,6
Wheelseat Wheelseat diameter	e	12,5	0,8/1,6 <sup>(3)</sup>
Lead in taper	f (detail U)		1,6
Body			
Inner transitional radii to wheelseat	g (detail T)	—	1,6
Axle body diameter	l		3,2 <sup>(2)</sup>
Brake disc seat diameter	h	12,5	0,8/1,6 <sup>(3)</sup>
Bearing seat and seal seat diameter	j	12,5	0,8
Transitional radii between two seats	k (detail S)		1,6
Bore Diameter	m (detail R1)		3,2

<sup>(1)</sup> For old axle types with plain bearing journals, the requirements are in the standards that deal with these products.

<sup>(2)</sup> 6,3 may be agreed if both the fatigue limits *F1* or *F2* defined in 5.5.2.1.4. and the sensitivity required for the in-service ultrasonic control are achieved.

<sup>(3)</sup> In-service Non Destructive Examination of axles may require smaller values of surface finish.

▼ B

Figure M3

Roughness symbols

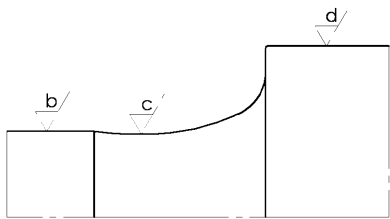
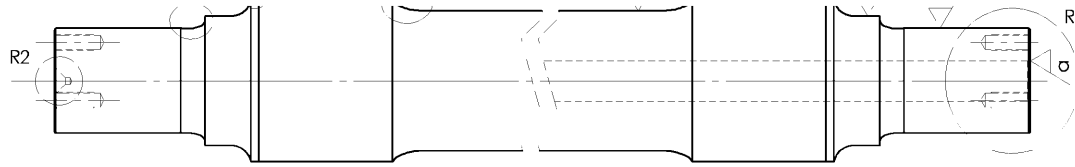

Detail V

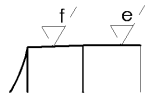

Detail U

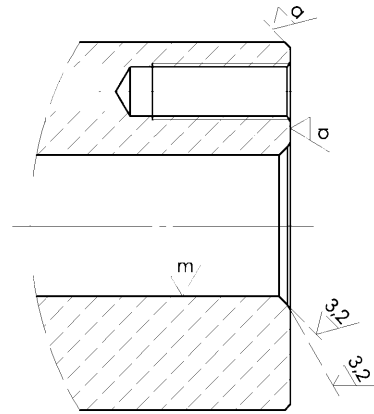

Detail R1

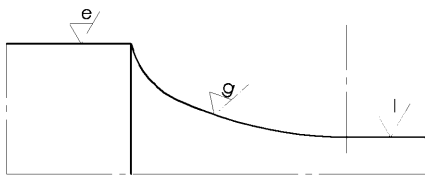

Detail T

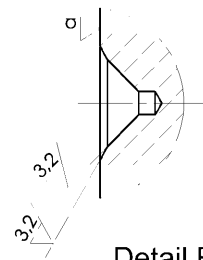

Detail R2

**▼B***M.2.6.2. Surface integrity*

Surface integrity shall be determined by a magnetic particle test for all axles for the external surfaces and additionally for hollow axles by an ultrasonic examination or an equivalent method for the bore surface. On the external surface of the axle, transverse defects are not permissible.

*M.2.6.3. Geometrical and dimensional tolerances*

The required geometrical tolerances are given in table M5. Symbols used are shown in figure M4.

The required dimensional tolerances are given in table M6. Symbols used are shown in figure M5.

*Table M5*

Designation	Symbol	Geometrical tolerances <sup>(1)</sup> <sup>(2)</sup> (mm)	
		Rough – machined	Finished or Ready for Assembly
Journal and abutment			
Journal cylindricity	n		0,015
Run out of the vertical face of the abutment relative to the reference Y-Z	o <sub>1</sub>		0,03
Run out of the abutment relative to the reference Y-Z	o <sub>2</sub>		0,03
Wheelseat			
Run out relative to the reference Y-Z	p	1,5	0,03
Cylindricity		0,1	0,015
Axle body			
Run out relative to the reference Y-Z	t		0,5
Bore			
Concentricity relative to the reference Y-Z	u		0,5
Holes for fixing axle end caps			
Concentricity relative to the reference Y-Z	v		0,5
Machining centre run out relative to the reference Y-Z (details R1/R2)	w <sub>1</sub> w <sub>2</sub>		0,02 0,03

(1) For parameters which do not have a tolerance defined in this table, the general tolerances of EN 22768-2 shall be applied.

(2) For old axle types with plain bearing journals, the requirements are in the standards that deal with these products.

▼ B

Figure M4

Geometrical symbols

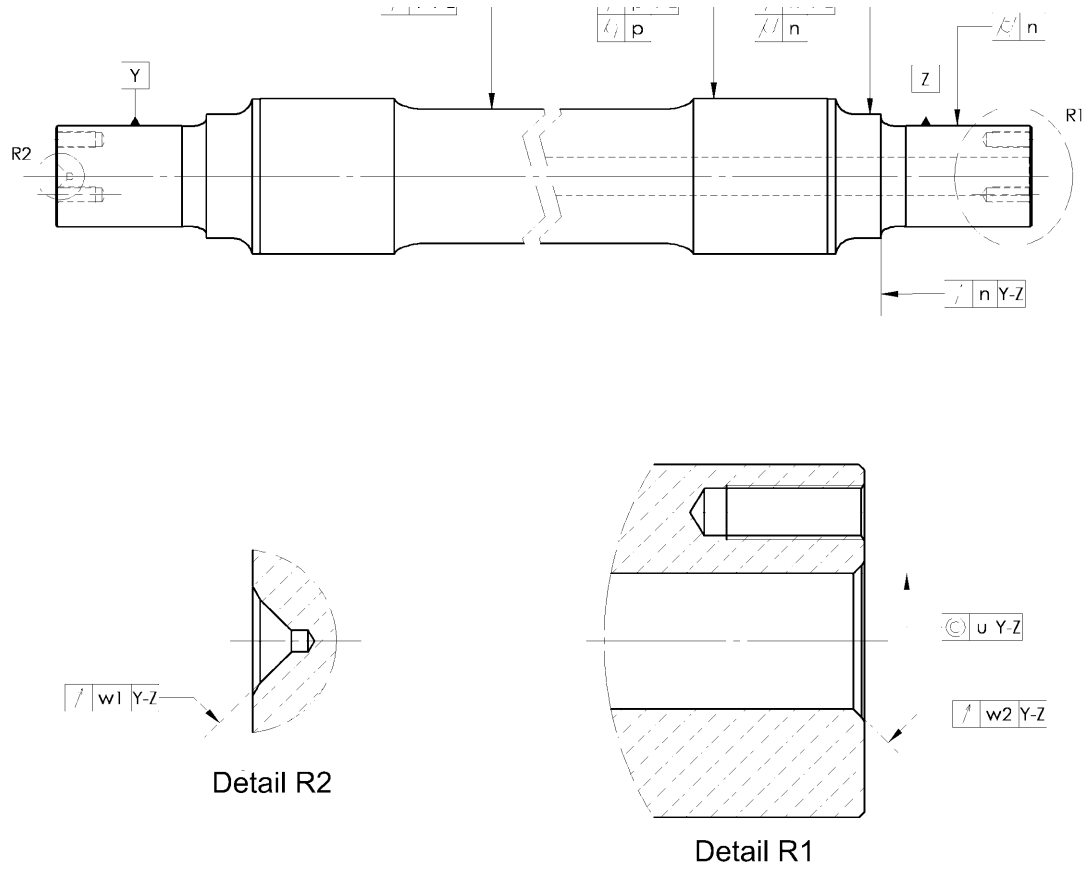





Table M6

Designation	Symbol	Dimensional tolerances <sup>(1)</sup> (mm)
		Ready for assembly
Longitudinal sizes.		
Length of axle <sup>(2)</sup>	A	± 1
Length of wheelseat (including collar)	B	0/-0,5
Length over abutments (between reference planes)	C	± 0,5 <sup>(5)</sup>
Journal bearing seat length	D	<sup>(3)</sup>
Abutment length	E	+1/0
Depth of journal groove		See detail V
Length of journal groove	G	detail V <sup>(3)</sup>
Diameters		
Diameter of journal	H	<sup>(3)</sup>
Wheelseat diameter	I	
Abutment diameter	N <sup>(3)</sup>	<sup>(3)</sup>
Diameter of body	P	+2/0
Sizes of other parts of axles		
Axle machining centres		
Plain axles		See detail R2 <sup>(4)</sup>
Hollow axles		See detail R1 <sup>(4)</sup>
Holes for fixing axle end caps	See detail R1 <sup>(4)</sup>	
Drilling concentricity		0,5
Drilling depth		+2/0
Thread depth		+2/0
Variation between drilling and thread		≥10
Lead in taper		
Wheelseat conical length	K (detail U) <sup>(3)</sup>	0/-3
Wheelseat taper depth	L (detail U) <sup>(3)</sup>	0,1
Diameter of bore	O (detail R1)	1
Transitional radii — wheelseat/body		See detail T <sup>(3)</sup>

<sup>(1)</sup> For parameters which do not have a tolerance defined in this table, the general tolerances of EN 22768-2 shall be applied.

<sup>(2)</sup> Attention is drawn to the fact that compliance with tolerances over the total length 'A' shall not allow all the individual tolerances to be applied cumulatively to the particular dimensions.

<sup>(3)</sup> According to the requirements of the drawing or documents accompanying the order.

<sup>(4)</sup> Other geometries may be proposed and defined in the order.

<sup>(5)</sup> Other values may be agreed for special applications.

▼ B

Figure M5

Dimensional symbols

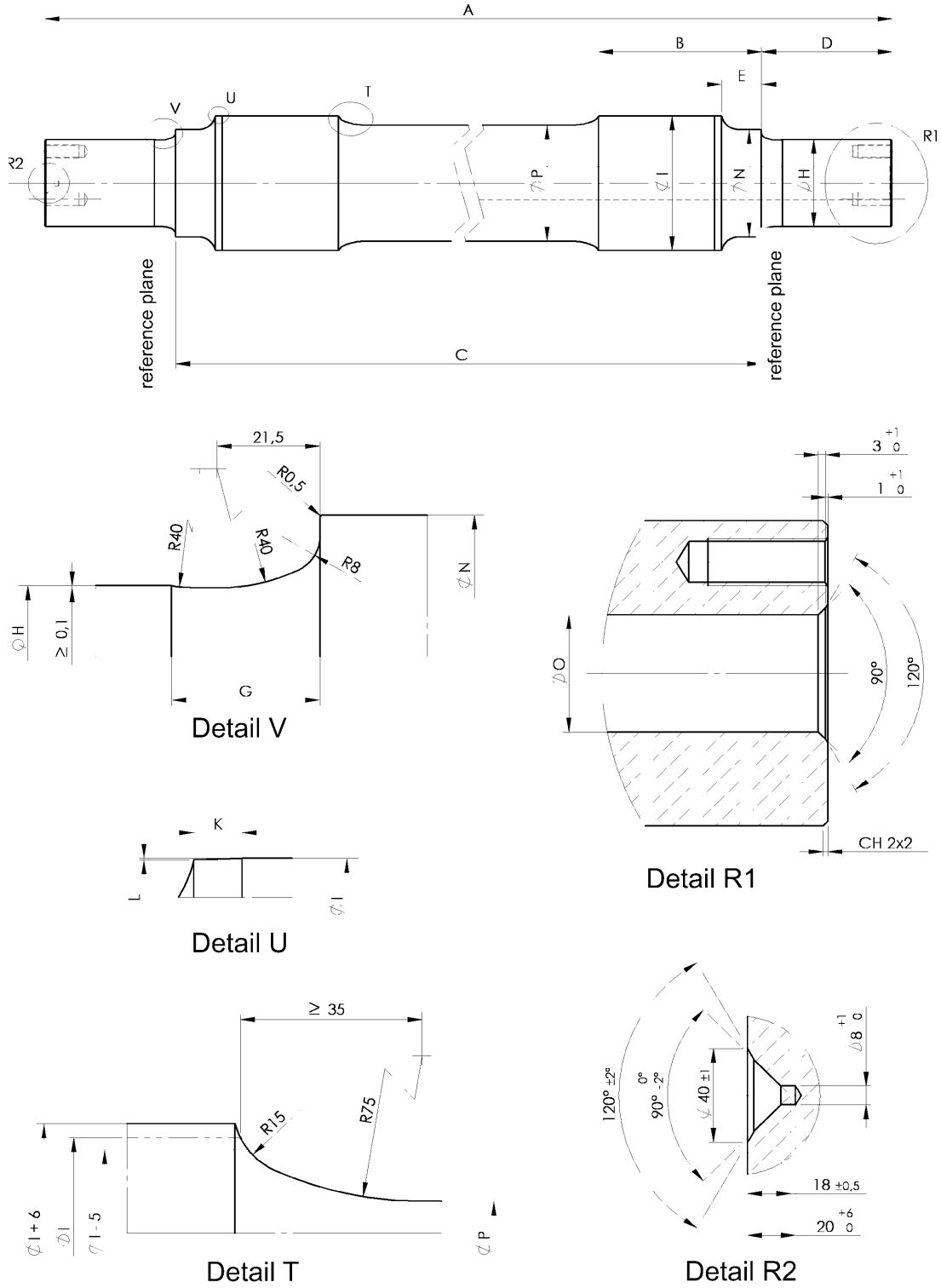

**▼B**

**M.2.7 Final protection against corrosion**

M.2.7.1 *General*

All exposed axle surfaces shall be protected as defined by the wheelset design specification.

M.2.7.2. *Resistance to specific corrosive products*

The protection systems applied to the exposed axle surfaces shall consider; environmental factors, corrosive materials, vehicle cargo, mechanical damage, etc.



## ANNEX N

## STRUCTURE AND MECHANICAL PARTS

## Permissible stresses for static test methods

## N.1 STATIC TEST METHODS

## N.1.1 Limits values for static tests to verify fatigue strength

Definition of the notch cases

The limit stresses to be used for wagon body tests are indicated, for three steels with a minimum tensile resistance of 370, 420 and 570 MPa, and for five notch cases defined in a general way as follows:

- Case A: Parent metal,
- Case B: Butt weld,
- Case C: Butt weld with inertia change,
- Case D: Fillet weld,
- Case E: Projection weld.







These five notch cases do not cover the full range of structures and, in practice, it is necessary to choose the most suitable notch case for each welded zone tested.

To facilitate and standardize these choices figures in Table Nx gives practical examples of welded joints which occur frequently in vehicle body structures and in bogies frames.

Fig. N1

Case	Sketch	Description	Comments
A		Away from weld	Away from weld
		Machined butt weld	Machined butt weld
B		Butt weld	Butt weld
		Butt weld with bevelling	
B		Machined and welded joint	
C		Corner joint with gusset plates	Butt weld between pieces at an angle to each other

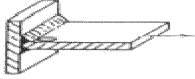
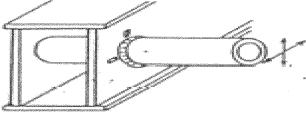
▼ **B**

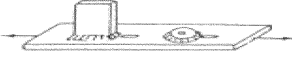
Case	Sketch	Description	Comments
C		Inclined joint	
D		Corner joint	Butt weld at 90°
D		Reinforced plate	Lap joints
D		Butt welded lap joint	
D		Corner joint	Fillet welds
D		Joint between tube and straight piece	
D		Joint between plate and tube	
D		Joint between plate and web	
E		Welded securing lug Welded securing stud	

**▼B**

Table N.1

		$2\sigma_{A\text{lim}}$ [N/mm <sup>2</sup> ]			$\Sigma_{m\text{lim}}$ [N/mm <sup>2</sup> ]			$\sigma_{m\text{axim}}$ [N/mm <sup>2</sup> ]		
					K = 0.3			K = 0.3		
Steel <sup>(1)</sup>		370	420	520	370	420	520	370	420	520
Notch case	A	110	118	166	183	197	277	238	258	360
	B	90	90	90	150	150	150	195	195	195
	C	80	80	80	133	133	133	173	173	173
	D	66	66	66	110	110	110	143	143	143
	E	54	54	54	90	90	90	117	117	117

<sup>(1)</sup> Characteristic tensile strength  $R_m$  according to material standard.

<sup>(2)</sup> Stress is determined by the elastic limit  $R_p$  or  $R_{p'}$ .



## ANNEX O

## ENVIRONMENTAL CONDITIONS

## TRIV requirements

Design level for temperature class T<sub>RIV</sub>

This table specifies temperature ranges for components used on interoperable freight wagons in operation before the implementation of this TSI.

Component	Specification
Buffers with a stroke of 105 mm	In the temperature-range from - 25 bis + 50 °C the technical values must not differ more than 20 % from the value at 'room-temperature'
Buffers with a stroke of 130 and 150 mm	In the temperature-range from - 25 bis + 50 °C the technical values must not differ more than 20 % from the value at 'room-temperature'.
Brakes – Regulations governing the construction of different types of braking gear — Simple pressure receptacles of steel, not fired, for air braking equipment and auxiliary pneumatic equipment for railway rolling stock	Temperature range for pressure receptacles: -40 °C to + 100 °C
Brakes – Regulations concerning manufacture of the different brake parts: Derailment detectors for wagons	Temperature range from - 40 °C to + 70 °C
Dimensions of hose connections (brake hoses) and electric cables; types of pneumatic and electric connections and their positioning on wagons and coaches equipped with automatic couplers of the UIC and OSJD Member Railways	Temperature range from - 40 °C to + 70 °C
Technical specification for the official testing and supply of greases intended for the lubrication of railway vehicle roller bearing axle boxes	Min. Temperature for testing: — 20 °C



ANNEX P

**BRAKING PERFORMANCE**

**Assessment of interoperability constituents**

P.1. DESIGN ASSESSMENT

The following lists contains brake system and brake constituent designs that at the time of publication are already considered to meet the requirements of this TSI for some applications. This list will be found in Annex FF.

**P.1.1. Distributor**

Open point

The test procedure for product design assessment to be used for the Interoperability Constituent distributor shall conform to this TSI.

**P.1.2. Relay valve for variable load and automatic empty-load change-over**

Open point

*P.1.2.1. Relay valve for variable load*

The design assessment of the interoperability constituent variable load relay valve is described here, whilst the specification is described in TSI 4.2.4.1.2.2 Braking Power and 4.2.4.1.2.7 Air Supply and the features described in Annex I chapter I.2.1.

The relay shall be tested as an individual unit for the following features when operating at temperatures of - 25 to + 45 °C:

- Application & Release times over the complete load range in accordance with section 4.2.4.1.2.2 of this TSI.
- Graduable application and release of the brakes (minimum 5 steps)
- Variations in output pressure with load signal variation.
- Response time to change in load signal variation. Change within 1 minute.
- No leakage when operating at temperatures of - 25 to + 45 °C

The test results at temperatures of - 25 to + 45 °C must not affect the operation of the vehicle or the train.

The relay valve shall be tested as an individual unit for the above features when operating at extreme temperatures of - 40 to - 25 °C and/or + 45 to + 70 °C. Test results can vary from the results between - 25 °C and + 45 °C at these extreme temperatures, but shall not affect the ability to operate the train.

The assessment of the variable load relay valve in the system is to be carried out when fitted in a brake system having an Interoperable Constituent distributor.

The following tests shall be carried out on an individual wagon randomly selected, equipped with at least one variable load relay valve. The change in load shall be both rising and falling through the full range and the vehicle shall be moved before the next set of measurements following a change in load.

- Verification of the brake mass percentages for 120 km/h running. Progressive degradation from a brake mass percentage of 100 % to 90 % is allowed for block braked wagons as the load increases from 18 to 20 tonne axle loads according to this TSI.
- Verification of the brake mass percentages for 100 km/h running. Progressive degradation from a brake mass percentage of 100 % to 65 % is allowed for wagons progressively as the load increases from 65 % of the wagons maximum permissible weight (14,5 tonne axle load for a wagon designed for 22,5 tonne axle loads) to its maximum weight according to this TSI. The braked mass for wagons fitted with cast iron block brakes shall not exceed 18 tonnes according to the international technical rules available at the time covering all Member States.
- Application & Release times over the complete load range
- Graduable application and release of the brakes (minimum 5 steps)



**▼B**

- Variations in output pressure with load signal variation
- Response time to change in load signal variation
- Impact and short duration load variations not affecting load adjustment
- Leakage

Running tests shall be carried out to verify:

- The equipment is insensitive to random load variations due to the movement of the vehicle
- The brake mass percentages with (i) empty, (ii) half-loaded, (iii) load corresponding to a brake mass percentage of 100 % and (iv) full load. The brake mass percentage shall not exceed 130 % irrespective of the load value, and for block braked wagons running at 120 km/h in the full load condition shall not exceed 105 %

#### P.1.2.2. *Relay valve for automatic empty-load*

The design assessment of the interoperability constituent automatic empty/load relay valve is described here, whilst the specification is described in TSI 4.2.4.1.2.2 Braking Power and 4.2.4.1.2.7 Air Supply and the features described in Annex I chapter I.2.2.

The relay will be tested as an individual unit for the following features when operating at temperatures of - 25 to + 45 °C:

- Application & Release times over the complete load range
- Graduable application and release of the brakes (minimum 5 steps)
- Variations in output pressure with load signal variation
- Response time to change in load signal variation
- No leakage when operating at temperatures of - 25 to + 45 °C

The test results at temperatures of - 25 to + 45 °C must not affect the operation of the train.

The relay valve shall be tested as an individual unit for the above features when operating at extreme temperatures of - 40 to - 25 °C and ~~or~~ + 45 to + 70 °C. Test results can vary from the results between - 25 °C and + 45 °C at these extreme temperatures, but shall not affect the ability to operate the train.

The assessment of the automatic empty/load relay valve in the system is to be carried out when fitted in a brake system having an Interoperable Constituent distributor. Tests shall be carried out on an individual wagon equipped with at least one an automatic empty/load relay valve. Tests shall be carried out in the empty and loaded conditions. The vehicle will be progressively loaded & unloaded in order to ascertain that the automatic changeover mechanism transfers from the 'loaded' to 'empty' mode, rising & falling, within the ± 5 % transition weight range. Where the equipment is designed to operate with varying load with the empty/load equipment, the running tests will be with the load at loads varied around the changeover weight to ensure that the mechanism is not affected by random load variations during normal operation. Tests will be carried out statically on an individual vehicle and in a train formation of a minimum of 15 wagons fitted with 4 axles which are all fitted with Interoperable Constituent distributors. If test results conform with the above requirements, the tests will be carried out dynamically on an individual vehicle. Tests will include:

- Application & Release times in both modes
- Graduable application and release of the brakes (minimum 5 steps)
- Brake Application Time in both modes
- Brake Release Time in both modes
- Variations in output pressure with load signal variation
- Response time to change in load signal variation
- Leakage

Running tests may be carried out if required by the Notified Body.

**▼ B****P.1.3. Wheel slide protection device**

## Open point

The design assessment of the interoperability constituent Wheel slide protection device is described here, whilst the specification is described in TSI 4.2.4.1.2.6 wheel slide protection and 4.2.4.1.2.7 Air Supply and the features described in Annex I chapter I.3.

The tests with the WSP shall be carried out either on a modern 4-axle vehicle or on a validated test rig, which faithfully represents the track geometry, adhesion conditions, vehicle parameters, etc. and validated on a modern 4-axle vehicle.

If the test vehicle is fitted with any brakes not dependent on adhesion these shall be isolated. When these brakes are activated, the WSP shall work properly: tests are required to confirm this. The test vehicle shall have a brake system representative of the system for which the WSP has been designed (of disc and/or block).

The following shall be measured/recorded as a minimum during all the testing of the WSP system:

- Vehicle speed
- Speed of individual axles
- Brake cylinder pressures
- Vehicle deceleration
- Auxiliary reservoir pressure
- Time
- Commencement of braking
- Activation of the dump valves
- Stopping distance
- Stopping time

The executions of the tests shall be made in accordance with this TSI.

**P.1.4. Slack adjuster**

The design assessment of the Interoperability Constituent slack adjuster shall be made by ensuring the mechanical strength is suitable for the load to be transmitted. Interchangeable slack adjusters are shown in Annex I, Section I.4 with their permitted maximum loads. The assessment will also ensure that the friction pair distance can be maintained within sensible limits so that the friction pair do not touch each other without braking, the braking characteristics are maintained and the braking performance is guaranteed.

A life test shall be performed to demonstrate the suitability of the unit for service on railway vehicles and to verify the maintenance requirements for the operational design life. This shall be carried out at the maximum rated load cycling through the full range of adjustment.

**P.1.5. Brake cylinder/actuator**

The design assessment of the interoperability constituent brake cylinder/actuator is described here, whilst the specification is described in 4.2.4.1.2.2 Braking Power, 4.2.4.1.2.8 Parking Brake, 4.2.4.1.2.5 Energy Limits and 4.2.4.1.2.7 Air Supply and the features described in Annex I chapter I.5.

The mechanical strength shall be assessed to ensure that it is suitable for the mechanical load to be transmitted, mechanical fixings and for the air pressures employed, including over pressure situations due to fault conditions. A full dimensional check shall be carried out. Interchangeable brake cylinders are shown in Annex I, Section I.5 with their permitted dimensions.

The brake cylinder/actuator shall be tested. The features to be tested are:

- No leakage at minimum and maximum stroke with a low input pressure (approximately 0,35 bar) for temperatures of - 25 to + 45 °C
- No leakage at minimum and maximum stroke with a high input pressure (at least 3,8 bar) for temperatures of - 25 to + 45 °C
- Maximum design stroke

**▼B**

— Pressure required to move the load rod, at the commencement of the movement and at the point of reaching full stroke

The test results at temperatures of - 25 to + 45 °C must not affect the operation of the train.

The brake cylinder/actuator shall be tested as an individual unit for the above features when operating at extreme temperatures of - 40 to - 25 °C and + 45 to + 70 °C. Test results can vary from the results between - 25 °C and + 45 °C at these extreme temperatures, but shall not affect the ability to operate the train.

If the brake cylinder or actuator has a slack adjuster, then the features listed under P.1.4 shall be assessed.

A life test shall be performed to demonstrate the suitability of the brake cylinder or actuator for service on railway vehicle and to verify the maintenance requirements the operational design life. This shall be carried out at the maximum rated load cycling through the full range of strokes (and range of adjustment for those fitted with slack adjusters).

**P.1.6. Pneumatic half coupling**

The Pneumatic half coupling shall be fully dimensionally checked to conform with the details in Annex I, section I.6, and the manufacturers drawings. A representative sample of 10 out of a minimum batch of 25 shall be tested for coupling and to ensure no leakage at 10 bars when operating at temperatures of - 25 and + 45 °C.

The pneumatic half coupling shall be tested as an individual unit for the above features when operating at extreme temperatures of - 40 to - 25 °C and/or + 45 to + 70 °C. Test results can vary from the results between - 25 °C and + 45 °C at these extreme temperatures, but shall not affect the ability to operate the train.

**P.1.7. End Cocks**

Open point

The design assessment of the Interoperability Constituent end cocks is described here, whilst the features are described in Annex I chapter I.7.

Check of physical and geometrical characteristics: The requirement of Annex I, I.7.4, I.7.7, and figures I.7.2 to I.7.5 as applicable shall be checked.

The executions of the tests shall be made in accordance with this TSI.

**P.1.8. Isolating device for distributor**

The design assessment of the Interoperable Constituent Isolating device for distributor is described here whilst the features are described in Annex I chapter I.8.

The Isolating device shall be tested & checked as follows:

- Movement of handle
- No leakage through the cock when closed when operating at temperatures of - 25 to + 45 °C
- No leakage from the cock to atmosphere when the cock is open or closed with a low input pressure of 0,35 bar
- No leakage from the cock to atmosphere when the cock is open or closed with a high input pressure of 7 bar

The isolating device for distributor shall be tested as an individual unit for the above features when operating at extreme temperatures of - 40 to - 25 °C and/or + 45 to + 70 °C. Test results can vary from the results between - 25 °C and + 45 °C at these extreme temperatures, but shall not affect the ability to operate the train.

**P.1.9. Brake pads**

The Test procedures for design assessment to be used for the interoperability constituents' brake pads and discs are to be made in accordance with this TSI.

**▼M1****P.1.10. Brake blocks**

The test procedure for design assessment to be used for the Interoperability Constituent brake blocks is to be carried out in accordance with the specification in Annex I section I.10.2. This specification is still an open point for composite brake blocks.

Composite brake blocks that are already in use have passed the assessment according to P.2.10 successfully. The list of fully approved composite brake blocks for international transport is set out in a Technical Document to be published by the European Rail Agency on its website.

**▼B****P.1.11. Accelerator valve**

Open point

The Test procedures for design assessment to be used for the interoperability constituent accelerator valve are to be made in accordance with this TSI.

**P.1.12. Automatic variable load sensing and empty/load changeover device**

Open point

*P.1.12.1. Automatic variable load sensing device*

The design assessment of the Automatic variable load sensing device is described here, whilst the features of the valve are specified in Annex I, section I.12.1. The tests to show conformity are listed below:

- Static test of load verses output pressure with rising and falling loads.
- Running test to demonstrate that shocks or variations will not affect the output brake force.
- Running test to demonstrate that air consumption is not excessive and will not affect normal operation of the air brake system.

The executions of the tests shall be made in accordance with this TSI.

*P.1.12.2. Empty/load changeover device*

The design assessment of the empty/load changeover device is described here, whilst the features of the valve are specified in Annex I, section I.12.2. The tests to show conformity are listed below:

- Static test to show change in output with movement of the measuring device or a load change.
- Static test to show delay to output signal caused by measuring device movement, that would cause a change of output, for greater than 3 seconds.
- Running test to demonstrate that shocks or variations will not affect the output signal.
- Running test to demonstrate that air consumption is not excessive and will not affect normal operation of the air brake system.

The executions of the tests shall be made in accordance with this TSI.

**P. PRODUCT ASSESSMENT****P.2.1. Distributor**

Every Distributor shall be tested. The features are specified in Annex I, section I.1 and those to be tested are listed below:

- Graduable application and release of the brakes
- Brake Application Time
- Brake Release Time
- Manual Distributor Release Valve
- Automatic operation

**▼B**

- Sensitivity and Insensitivity
- Leakage
- Charging time of Brake supply (auxiliary) reservoir
- Charging time of control reservoir (may not apply to electrically/electronically controlled distributor)

**P.2.2. Relay valve for variable load and empty/load**

Every Relay valve shall be tested. The features are specified in Annex I, section I.2 and those to be tested are listed below:

- Graduable application and release of the brakes (minimum 5 steps)
- Brake Application Time
- Brake Release Time
- Variations in output pressure with load signal variation
- Response time to change in load signal variation
- No change in output pressure to load signal variations during an application (variable load only)
- Leakage

**P.2.3. Wheel slide protection device**

Every WSP control unit, sensors and dump valves shall be tested. The features of the wheel slide protection device are described in 4.2.4.1.2.6 Wheel Slide Protection and 4.2.4.1.2.7 Air Supply and specified in Annex I, section I.3. The features shall be tested by a self-test programme that has a fault diagnostic display to identify any faults. Random faults shall be introduced to check the self-test.

**P.2.4. Slack adjuster**

Every slack adjuster shall be tested. The features to be tested are:

- Maximum take up
- Maintenance of set clearance
- Incremental take up
- Letting out when no clearance to obtain set clearance (double acting units only)
- Ability to reset to minimum length (contracting slack adjuster) or maximum length (extending slack adjuster)

**P.2.5. Brake cylinder/actuator**

Every Brake cylinder/actuator shall be tested. The features to be tested are:

- No leakage at minimum and maximum stroke with the low input pressure
- No leakage at minimum and maximum stroke with the high input pressure
- Maximum stroke
- Pressure to move load rod

If the brake cylinder or actuator has a slack adjuster, then the features listed under P.2.4 shall be tested.

**P.2.6. Pneumatic half coupling**

Every Pneumatic half coupling shall be tested to ensure no leakage at 10 bars.

**P.2.7. End Cocks**

Every End cock shall be tested. The features are specified in Annex I, section I.7 and those to be tested are listed below:

- Movement of handle
- Torque

**▼B**

- No leakage through the cock when closed
- No leakage from the cock to atmosphere when the cock is open or closed with a low input pressure.
- No leakage from the cock to atmosphere when the cock is open or closed with an input pressure of 10 bars
- Venting of hose side of cock

**P.2.8. Isolating device for distributor**

Every Isolating device shall be tested. The features are specified in Annex I, section I.8 and those to be tested are listed below:

- Movement of handle
- No leakage through the cock when closed
- No leakage from the cock to atmosphere when the cock is open or closed with the low input pressure.
- No leakage from the cock to atmosphere when the cock is open or closed with the high input pressure.

**P.2.9. Brake pads**

Samples of each batch of pads will be dimensionally checked.

**P.2.10. Brake blocks**

- Geometrical assessment

Samples of each batch of blocks shall be dimensionally checked.

- Assessment procedure for composite brake blocks. The Test procedure is an open point

During the transitional period the assessment test performed by UIC shall at least comprise:

**Rig Testing and Analysis**

Composite brake blocks shall be assessed using a standardised test procedure and standardised test rig (ERRI B126/RP 18, 2. version, March 2001). The following criteria shall be examined:

- Brake block performance in dry, wet and drag braking
- Probability of metal pickup from the wheel
- Performance in adverse winter weather conditions (e.g. snow, ice, low temperature)
- Performance in the case of brake failure (brakes locked on)
- Assessment of effects on the electrical resistance of the wheelset (including specific test of compatibility with track circuits in the different countries where the vehicle is intended to operate)

**Climactic Test Chamber Assessment**

Before proceeding to on-vehicle brake performance tests, the composite brake block shall successfully complete a programme of rig testing as described above.

***Brake performance tests on the subsystem:***

Composite brake blocks shall be:

- assessed according to Annex S of this TSI
- proven in operational service in Northern Europe throughout one complete winter period
- assessed for wheel roughness in compliance with TSI noise
- assessed for the affects on the electrical resistance of the wheelset

Service Evaluation for new products other than composite blocks shall be conducted according to section 6 and Annex Q.

**▼B****P.2.11. Accelerator valve**

Every Accelerator valve shall be tested. The features are specified in Annex I, section I.11.

**P.2.12. Automatic variable load sensing and empty/load changeover device***P.2.12.1. Automatic variable load sensing device*

Every sensing device shall be tested. The features are specified in Annex I, section I.12.1 and those to be tested are listed below:

- Load verses output pressure with rising and falling loads
- No leakage

*P.2.12.2. Empty/load changeover device*

Every changeover device shall be tested. The features are specified in Annex I, section I.12.2 and those to be tested are listed below:

- Change in output with movement of measuring device/load change
- Delay to output signal caused by measuring device movement, which would cause a change of output, for greater than 3 seconds.
- No leakage.

**P.3. TEST PROCEDURE CHARACTERISTIC**

Test Procedure Characteristics		
No	Characteristic	Limit Value
	First stroke in percent of the maximum brake shoe pressure for 'goods' brake	About 10 %
	High pressure overcharge to 6 bar brake pipe pressure, following a full service application, shall not trigger a brake application if sustained for:-	Passenger Setting Up to 40 seconds <u>Goods Setting</u> Up to 10 seconds
	Transmission speed in the case of emergency braking	More or equal to 250 m/s
	Release time of a train after a full application	Passenger Setting Up to 25 seconds <u>Goods Setting</u> Up to 70 seconds
	Uneven filling, the brake being released	6 bar for a period of 2 s. (minimum). Return from 6 bar to 5,2 bar in 1 s.: The brake must not operate during this test.
	Inexhaustibility. Percentage of reduction in the average pressure in the brake cylinder.	Maximum 15 %
	Operation of the brake with no disturb and compliant to this TSI: Emergency application, full application, gradual application, adjustability on release.	Test has to be done to show no disturbance and compliance in different braking configurations.
	Automatic compensation for leakage at the brake cylinders.	During service braking and emergency braking, a leakage of 1 mm diameter shall be compensated without delay.



ANNEX Q

**ASSESSMENT PROCEDURES**

**Interoperability Constituents**

**Modules for Interoperability Constituents:**

- Characteristics
- Module A: Internal production control
- Module A1: Internal design control with product verification
- Module B: Type examination
- Module C: Conformity to type
- Module D: Production quality management system
- Module F: Product verification
- Module H1: Full quality management system
- Module H2: Full quality management system with design examination
- Module V: Type validation by in service experience (Suitability for use)

**Characteristics**

The characteristics of the interoperability constituents to be assessed in the different phases of design and production are marked by an 'X' in Table Q.1.

*Table Q.1*

Characteristics to be assessed	Assessment in the following phase					
	Design and development phase				Production phase	Modules
	Design review	Review of manufacturing process	Type test	In service experience (Module V)	(Series)	
Buffers conventional					X	A, H1
Buffers new design	X	X	X		X	B + F, B + D, H1
Screw coupler conventional			X		X	A, H1
Decals for marking			X		X	A, B +C, H1
Bogie and running gear conventional					X	A1, H1,
Bogie and running gear new design	X	X	X	X	X	B + D, B + F, H2, V
Wheelsets conventional					X	A1, H1,
Wheelsets new design	X	X	X	X	X	B + D, B, + F, H2, V
Wheels conventional					X	A1, H1,
Wheels new	X	X	X	X	X	B+ D, B + F, H2,V
Axles conventional					X	A1, H1,



## ▼ B

Characteristics to be assessed	Assessment in the following phase					
	Design and development phase				Production phase	Modules
	Design review	Review of manufacturing process	Type test	In service experience (Module V)	(Series)	
Axles new	X	X	X	X	X	B + D, B + F, H2, V
Roller bearings conventional					X	A1, H1,
Roller bearings new	X	X	X	X	X	B + D, B + F, H2
Distributor valve <sup>(1)</sup>	X	X	X	12 Month after modifying an existing model or 24 Month for other cases	X	B+D, B+F, H2, V <sup>(2)</sup>
Relay valve for variable load <sup>(1)</sup>	X	X	X	12 Month	X	B+D, B+F, H2, V <sup>(2)</sup>
Wheel slide protection device <sup>(1)</sup>	X	X	X	12 Month	X	B+D, B+F, H2, V <sup>(2)</sup>
Slack adjuster <sup>(1)</sup>	X	X	X	12 Month	X	B+D, B+F, H2, V <sup>(2)</sup>
Brake cylinder/actuator <sup>(1)</sup>	X	X	X	12 Month	X	B+D, B+F, H2, V <sup>(2)</sup>
Relay valve for automatic empty-load change-over <sup>(1)</sup>	X	X	X	12 Month	X	B+D, B+F, H2, V <sup>(2)</sup>
Pneumatic half coupling <sup>(1)</sup>	X	X	X	12 Month	X	B+D, B+F, H2, V <sup>(2)</sup>
End cock <sup>(1)</sup>	X	X	X	12 Month	X	B+D, B+F, H2, V <sup>(2)</sup>
Isolating device for distributor valve <sup>(1)</sup>	X	X	X	12 Month	X	B+D, B+F, H2, V <sup>(2)</sup>
Brake pad and disk <sup>(1)</sup>	X	X	X	18 Month	X	B+D, B+F, H2, V <sup>(2)</sup>
Brake blocs <sup>(1)</sup>	X	X	X	18 Month	X	B+D, B+F, H2, V <sup>(2)</sup>
Brake pipe emptying accelerator valve <sup>(1)</sup>	X	X	X	12 Month	X	B+D, B+F, H2, V <sup>(2)</sup>
Automatic variable load sensing <sup>(1)</sup>	X	X	X	12 Month	X	B+D, B+F, H2, V <sup>(2)</sup>
Empty/load change-over device <sup>(1)</sup>	X	X	X	12 Month	X	B+D, B+F, H2, V <sup>(2)</sup>

<sup>(1)</sup> For an IC already admitted, the assessment is limited to the 'integration test' when installed on the subsystem (new wagon) and 'Series' test during the production phase.

<sup>(2)</sup> When a result from one module is relevant for an other module, it is not necessary to repeat the test.

<sup>(3)</sup> The assessment of the manufacturing process is not necessary for a new IC, or for a different kind of IC, if there is little or no difference to an existing assessed manufacturing process, for example a distributor and empty/load change-over device.



## MODULES FOR INTEROPERABILITY CONSTITUENTS

### Module A: Internal Production Control

1. This module describes the procedure whereby the manufacturer or his authorised representative established within the Community, who carries out the obligations laid down in point 2, ensures and declares that the interoperability constituent concerned satisfies the requirements of the TSI that apply to it.
2. The manufacturer must establish the technical documentation described in point 3.
3. The technical documentation must enable the conformity of the interoperability constituent with the requirements of the TSI to be assessed. It must, as far as relevant for such assessment, cover the design, manufacture, maintenance and operation of the interoperability constituent. So far as relevant for the assessment, the documentation must contain:
  - a general description of the interoperability constituent
  - conceptual design and manufacturing information, for example drawings and schemes of components, subassemblies, circuits, etc.
  - descriptions and explanations necessary for the understanding of the design and manufacturing information, maintenance and the operation of the interoperability constituent
  - the technical specifications including European specifications <sup>(1)</sup> with relevant clauses, applied in full or in part,
  - description of the solutions adopted to meet the requirements of the TSI, where the European specifications have not been applied in full,
  - results of design calculations made, examinations carried out, etc,
  - test reports.
4. The manufacturer must take all the measures necessary in order that the manufacturing process ensures compliance of each manufactured interoperability constituent with the technical documentation referenced in point 3 and with the requirements of the TSI that apply to it.
5. The manufacturer or his authorised representative established within the Community must draw up a written declaration of conformity for the interoperability constituent. The content of this declaration has to include at least the information indicated in Annex IV (3) and in Article 13 -3 of Directives 01/16/EC. The EC declaration of conformity and the accompanying documents must be dated and signed. The declaration must be written in the same language as the technical documentation and must contain the following:
  - the Directive references (Directives 01/16/EC and other directives to which the interoperability constituent may be subject),
  - the name and address of the manufacturer or his authorised representative established within the Community (give trade name and full address and in the case of an authorised representative also give the trade name of the manufacturer or constructor),
  - description of interoperability constituent (make, type etc.)
  - description of the procedure (module) followed in order to declare conformity,
  - all the relevant descriptions met by the interoperability constituent and in particular its conditions of use,
  - reference to this TSI and to any other applicable TSI, and where appropriate reference to European specifications,
  - identification of the signatory empowered to enter into commitments on behalf of the manufacturer or of his authorised representative established within the Community.

<sup>(1)</sup> The definition of an European specification is indicated in the directives 96/48/EC and 01/16/EC. The guide for application of HS TSIs explains the way to use the European Specifications

**▼B**

6. The manufacturer or his authorised representative must keep a copy of the EC declaration of conformity with the technical documentation for a period of 10 years after the last interoperability constituent has been manufactured. Where neither the manufacturer nor his authorised representative is established within the Community, the obligation to keep the technical documentation available is the responsibility of the person who places the interoperability constituent in the Community market.
7. If additional to the EC declaration of conformity, an EC declaration for suitability for use for the interoperability constituent is required by the TSI, this declaration has to be added after being issued by the manufacturer under the conditions of module V.

**MODULES FOR INTEROPERABILITY CONSTITUENTS****Module A1: Internal Design Control with Production Verification**

1. This module describes the procedure whereby the manufacturer or his authorised representative established within the Community, who carries out the obligations laid down in point 2, ensures and declares that the interoperability constituent concerned satisfies the requirements of the TSI that apply to it.
2. The manufacturer must establish the technical documentation described in point 3.
3. The technical documentation must enable the conformity of the interoperability constituent with the requirements of the TSI to be assessed. The technical documentation must also give evidence that the design of the interoperability constituent, already accepted before the implementation of the present TSI, is in accordance with the TSI and that the interoperability constituent has been used in service in the same area of use. It must, as far as relevant for such assessment, cover the design, manufacture, maintenance and operation of the interoperability constituent. So far as relevant for the assessment, the documentation must contain:
  - a general description of the interoperability constituent and its conditions of use,
  - conceptual design and manufacturing information, for example drawings and schemes of components, subassemblies, circuits, etc.
  - descriptions and explanations necessary for the understanding of the design and manufacturing information, maintenance and the operation of the interoperability constituent,
  - the technical specifications including European specifications <sup>(1)</sup> with relevant clauses, applied in full or in part,
  - descriptions of the solutions adopted to meet the requirements of the TSI, where the European specifications referenced to in the TSI have not been applied in full,
  - results of design calculations made, examinations carried out, etc,
  - test reports,
4. The manufacturer must take all the measures necessary in order that the manufacturing process ensures compliance of each manufactured interoperability constituent with the technical documentation referenced in point 3 and with the requirements of the TSI that apply to it.
5. The notified body, chosen by the manufacturer, must carry out the appropriate examinations and tests in order to verify the conformity of the manufactured interoperability constituents with the technical documentation referenced in point 3 and with the requirement of the TSI. The manufacturer <sup>(2)</sup> can choose one of the following procedures:

<sup>(1)</sup> The definition of an European specification is indicated in the directives 96/48/EC and 01/16/EC. The guide for application of HS TSIs explains the way to use the European Specifications

<sup>(2)</sup> When necessary, the manufacturer's discretion may be limited for specific constituents. In this case, the relevant verification process required for the interoperability constituent is specified in the TSI (or in its annexes)

**▼B**

- 5.1. Verification by examination and testing of every interoperability constituent
  - 5.1.1. Each product shall be individually examined and appropriate tests shall be carried out in order to verify the product conformity with the technical documentation and the requirements of the TSI that apply to it. When a test is not set out in the TSI (or in an European Standard quoted in the TSI), the relevant European Specifications or equivalent tests are applicable
  - 5.1.2. The notified body must draw up a written certificate of conformity for the approved products relating to the tests carried out.
- 5.2. Statistical verification
  - 5.2.1. The manufacturer must present his interoperability constituents in the form of homogeneous lots and shall take all measures necessary in order that the manufacturing process ensures the homogeneity of each lot produced.
  - 5.2.2. All interoperability constituents must be available for verification in the form of homogeneous lots. A random sample shall be drawn from each lot. Each interoperability constituents in a sample shall be individually examined and appropriate tests shall be carried out to ensure the product conformity with the technical documentation and the requirements of the TSI which apply to it and to determine whether the lot is accepted or rejected. When a test is not set out in the TSI (or in an European Standard quoted in the TSI), the relevant European Specifications or equivalent tests are applicable
  - 5.2.3. The statistical procedure must use appropriate elements (statistical method, sampling plan etc), depending on the characteristics to be assessed, as specified in the TSI.
  - 5.2.4. In the case of accepted lots, the notified body shall draw up a written certificate of conformity relating to the tests carried out. All interoperability constituents in the lot may be placed on the market except those interoperability constituents from the sample, which were found not to be in conformity.
  - 5.2.5. If a lot is rejected, the notified body or the competent authority must take appropriate measures to prevent placing that lot on the market. In the event of frequent rejection of lots the notified body may suspend the statistical verification.
6. The manufacturer or his authorised representative established within the Community must draw up the EC declaration of conformity of the interoperability constituent. The content of this declaration shall include at least the information indicated in Annex IV (3) of Directives 96/48/EC or 01/16/EC. The EC declaration of conformity and the accompanying documents must be dated and signed. The declaration must be written in the same language as the technical documentation and must contain the following:
  - the Directive references (Directives 96/48/EC or 01/16/EC and other directives to which the interoperability constituent may be subject),
  - the name and address of the manufacturer or his authorised representative established within the Community (give trade name and full address and in the case of an authorised representative also give the trade name of the manufacturer or constructor),
  - description of interoperability constituent (make, type, etc)
  - description of the procedure (module) followed in order to declare conformity,
  - all of the relevant descriptions met by the interoperability constituent and in particular any conditions of use,
  - name and address of notified body (bodies) involved in the procedure followed in respect of conformity and date of certificates together with the duration and conditions of validity of the certificates,
  - reference to the TSI and any other applicable TSI and where appropriate reference to European specifications,

**▼B**

- identification of the signatory empowered to enter into commitments on behalf of the manufacturer or of his authorised representative established within the Community.

The certificate to be referred to is the certificate of conformity as mentioned in point 5. The manufacturer or his authorised representative established within the Community must ensure that he is able to supply the notified body's certificates of conformity on request

7. The manufacturer or his authorised representative must keep a copy of the EC declaration of conformity with the technical documentation for a period of 10 years after the last interoperability constituent has been manufactured. Where neither the manufacturer nor his authorised representative is established within the Community, the obligation to keep the technical documentation available is the responsibility of the person who places the interoperability constituent in the Community market.
8. If additional to the EC declaration of conformity, an EC declaration for suitability for use for the interoperability constituent is required by the TSI, this declaration has to be added after being issued by the manufacturer under the conditions of module V.

## MODULES FOR INTEROPERABILITY CONSTITUENTS

### Module B: Type Examination

1. This module describes that part of the procedure by which a notified body ascertains and attests that a type, representative of the production envisaged, meets the provisions of the TSI that apply to it.
2. The application for the EC type-examination must be lodged by the manufacturer or his authorised representative established within the Community. The application must include:
  - the name and address of the manufacturer and also, if the application is lodged by the authorised representative, his name and address,
  - a written declaration that the same application has not been lodged with any other notified body,
  - the technical documentation, as described in point 3.

The applicant must place at the disposal of the notified body a specimen, representative of the production envisaged and hereinafter called 'type'.

A type may cover several versions of the Interoperability Constituent provided that the differences between the versions do not affect the provisions of the TSI.

The notified body may request further specimens if needed for carrying out the test programme.

If no type tests are requested within the type examination procedure, and the type is sufficiently defined by the technical documentation, as described in point 3, the notified body may agree that no specimens are placed at its disposal.

3. The technical documentation must enable the conformity of the interoperability constituent with the requirements of the TSI to be assessed. It must, as far as relevant for such assessment, cover the design, manufacture, maintenance and operation of the interoperability constituent.

The technical documentation must contain:

- a general type-description,
- conceptual design and manufacturing information, for example drawings and schemes of components, sub-assemblies, circuits, etc.,
- descriptions and explanations necessary for the understanding of the design and manufacturing information, maintenance and the operation of the interoperability constituent,
- conditions of integration of the interoperability constituent in its system environment (sub-assembly, assembly, subsystem) and the necessary interface conditions,

**▼B**

- conditions for use and maintenance of the interoperability constituent (restrictions of running time or distance, wear limits etc),
  - the technical specifications, including European specifications <sup>(1)</sup> with relevant clauses, applied in full or in part,
  - descriptions of the solutions adopted to meet the requirements of the TSI in cases where the European specifications have not been applied in full,
  - results of design calculations made, examinations carried out, etc.,
  - test reports,
4. The notified body must:
- 4.1. examine the technical documentation,
  - 4.2. verify that any specimen(s) required for test has (have) been manufactured in conformity with the technical documentation, and carry out or have carried out the type tests in accordance with the provisions of the TSI and/or the relevant European specifications,
  - 4.3. where a design review is requested in the TSI, perform an examination of the design methods, the design tools and the design results to evaluate their capability to fulfil the requirements for conformity for the interoperability constituent at the completion of the design process,
  - 4.4. where a review of the manufacturing process is requested in the TSI, perform an examination of the manufacturing process devised for manufacturing the interoperability constituent, to evaluate its contribution to product conformity, and/or examine the review carried out by the manufacturer at the completion of the design process,
  - 4.5. identify the elements which have been designed in accordance with the relevant provisions of the TSI and the European specifications as well as the elements which have been designed without applying the relevant provisions of those European Specifications;
  - 4.6. perform or have performed the appropriate examinations and necessary tests in accordance with points 4.2., 4.3. and 4.4. to establish whether, where the manufacturer has chosen to apply the relevant European specifications, these have actually been applied;
  - 4.7. perform or have performed the appropriate examinations and necessary tests in accordance with points 4.2., 4.3. and 4.4. to establish whether, where the relevant European specifications have not been applied, the solutions adopted by the manufacturer meet the requirements of the TSI;
  - 4.8. agree with the applicant the location where the examinations and necessary tests will be carried out.
5. Where the type meets the provisions of the TSI, the notified body must issue a type-examination certificate to the applicant. The certificate must contain the name and address of the manufacturer, conclusions of the examination, conditions for its validity and the necessary data for identification of the approved type.
- The time period of validity shall be no longer than 5 years.
- A list of the relevant parts of the technical documentation must be annexed to the certificate and a copy kept by the notified body.
- If the manufacturer or his authorised representative established within the Community is denied a type-examination certificate, the notified body must provide detailed reasons for such denial.
- Provision must be made for an appeals procedure.
6. The applicant must inform the notified body that holds the technical documentation concerning the type-examination certificate of all modifications to the approved product which must receive additional approval where such changes may affect the conformity with the requirements of the TSI or the prescribed conditions for use of the product. In this case, the notified body shall perform only those examinations and tests that are relevant and necessary to the changes. The additional approval may be

<sup>(1)</sup> The definition of an European specification is indicated in the directives 96/48/EC and 01/16/EC. The guide for application of HS TSIs explains the way to use the European Specifications

**▼B**

given either in the form of an addition to the original type-examination certificate, or, by the issue of a new certificate after withdrawal of the old one.

7. If no modifications as in point 6 have been made, the validity of an expiring certificate can be extended for another period of validity. The applicant will apply for such a prolongation by a written confirmation that no such modifications have been made, and the notified body issues a prolongation for another period of validity as in point 5, if no contrary information exists. This procedure can be reiterated.
8. Each notified body must communicate to the other notified bodies the relevant information concerning the type-examination certificates and additions issued, withdrawn or refused.
9. The other notified bodies may receive, on request, copies of the type-examination certificates issued and/or their additions. The annexes to the certificates (see § 5) must be kept at the disposal of the other notified bodies.
10. The manufacturer or his authorised representative established within the Community must keep with the technical documentation copies of type-examination certificates and their additions for a period of 10 years after the last interoperability constituent has been manufactured. Where neither the manufacturer nor his authorised representative is established within the Community, the obligation to keep the technical documentation available is the responsibility of the person who places the interoperability constituent on the Community market.

## MODULES FOR INTEROPERABILITY CONSTITUENTS

### Module C: Conformity to Type

1. This module describes that part of the procedure whereby the manufacturer or his authorised representative established within the Community ensures and declares that the interoperability constituent concerned is in conformity with the type as described in the type-examination certificate and satisfies the requirements of the TSI that apply to it.
2. The manufacturer must take all measures necessary to ensure that the manufacturing process ensures compliance of each manufactured interoperability constituent with the type as described in the EC type examination certificate and with the requirements of the TSI that apply to it.
3. The manufacturer or his authorised representative established within the Community must draw up an EC declaration of conformity for the interoperability constituent.

The content of this declaration has to include at least the information indicated in Annex IV (3) of Directives 96/48/EC or 01/16/EC. The EC declaration of conformity and the accompanying documents must be dated and signed.

The declaration must be written in the same language as the technical documentation and must contain the following:

- the Directive references (Directives 96/48/EC or 01/16/EC and other directives to which the interoperability constituent may be subject),
- the name and address of the manufacturer or his authorised representative established within the Community (give trade name and full address and in the case of an authorised representative also give the trade name of the manufacturer or constructor),
- description of interoperability constituent (make, type etc.)
- description of the procedure (module) followed in order to declare conformity,
- all the relevant descriptions met by the interoperability constituent and in particular its conditions of use,
- name and address of notified body (bodies) involved in the procedure followed in respect of type examination conformity and date of the

**▼B**

EC type examination certificate (and its additions) together with the duration and conditions of validity of the certificate,

- reference to the TSI and to any other applicable TSI, and where appropriate reference to European specifications <sup>(1)</sup>,
  - identification of the signatory empowered to enter into commitments on behalf of the manufacturer or of his authorised representative established within the Community.
4. The manufacturer or his authorised representative established within the Community must keep a copy of the EC declaration of conformity for a period of 10 years after the last interoperability constituent has been manufactured.

Where neither the manufacturer nor his authorised representative is established within the Community, the obligation to keep the technical documentation available is the responsibility of the person who places the interoperability constituent on the Community market.

5. If additional to the EC declaration of conformity an EC declaration of suitability for use for the interoperability constituent is required by the TSI, this declaration has to be added after being issued by the manufacturer under the conditions of module V.

## MODULES FOR INTEROPERABILITY CONSTITUENTS

### Module D: Production Quality Management System

1. This module describes the procedure whereby the manufacturer or his authorised representative established within the Community who satisfies the obligations of point 2 ensures and declares that the interoperability constituent concerned is in conformity with the type as described in the type-examination certificate and satisfies the requirements of the TSI that apply to it.
2. The manufacturer must operate an approved quality management system for production, final product inspection and testing as specified in point 3 and is subject to monitoring as specified in point. 4.
3. Quality management system
- 3.1. The manufacturer must lodge an application for assessment of his quality management system with a notified body of his choice, for the interoperability constituents concerned.

The application must include:

- all relevant information for the product category representative for the interoperability constituents envisaged,
  - the documentation concerning the quality management system,
  - the technical documentation of the approved type and a copy of the type-examination certificate, issued after the completion of the type examination procedure of module B.
  - a written declaration that the same application has not been lodged with any other notified body,
- 3.2. The quality management system must ensure compliance of the interoperability constituents with the type as described in the type-examination certificate and with the requirements of the TSI that apply to them. All the elements, requirements and provisions adopted by the manufacturer shall be documented in a systematic and orderly manner in the form of written policies, procedures and instructions. The quality management system documentation must permit a consistent interpretation of the quality programmes, plan, manuals and records.

It must contain in particular an adequate description of:

- the quality objectives and the organisational structure,

<sup>(1)</sup> The definition of an European specification is indicated in the directives 96/48/EC and 01/16/EC. The guide for application of HS TSIs explains the way to use the European Specifications



**▼B**

- responsibilities and powers of the management with regard to product quality,
- the manufacturing, quality control and quality management techniques, processes and systematic actions that will be used,
- the examinations, checks and tests that will be carried out before, during and after manufacture, and the frequency with which they will be undertaken,
- the quality records, such as inspection reports and test data, calibration data, qualification reports of the personnel concerned, etc.,
- the means to monitor the achievement of the required product quality and the effective operation of the quality management system.

- 3.3. The notified body assesses the quality management system to determine whether it satisfies the requirements of point 3.2. It presumes compliance with these requirements if the manufacturer implements a quality system for production, final product inspection and testing in respect of the Standard EN/ISO 9001- 2000, which take into consideration the specificity of the interoperability constituent for which it is implemented.

When the manufacturer operates a certified quality management system, the notified body shall take this into account in the assessment.

The audit must be specific for the product category, which is representative for the interoperability constituent. The auditing team must have at least one member experienced as an assessor in the product technology concerned. The evaluation procedure must include an inspection visit to the manufacturer's premises.

The decision must be notified to the manufacturer. The notification must contain the conclusions of the examination and the reasoned assessment decision.

- 3.4. The manufacturer must undertake to fulfil the obligations arising out of the quality management system as approved and to uphold it so that it remains adequate and efficient.

The manufacturer or his authorised representative established within the Community shall keep the notified body that has approved the quality management system informed of any intended updating of the quality management system.

The notified body must evaluate the modifications proposed and decide whether the amended quality management system will still satisfy the requirements of point 3.2 or whether a re-assessment is required.

It must notify its decision to the manufacturer. The notification must contain the conclusions of the examination and the reasoned assessment decision.

4. Surveillance of the quality management system under the responsibility of the notified body.
- 4.1. The purpose of surveillance is to make sure that the manufacturer duly fulfils the obligations arising out of the approved quality management system.
- 4.2. The manufacturer must allow the notified body entrance for inspection purposes to the locations of manufacture, inspection and testing, and storage and must provide it with all necessary information, in particular:
- the quality management system documentation,
  - the quality records such as inspection reports and tests data, calibration data, qualification reports of the personnel concerned, etc.
- 4.3. The notified body must periodically carry out audits to make sure that the manufacturer maintains and applies the quality management system and must provide an audit report to the manufacturer.

The frequency of the audits shall be at least once a year.

When the manufacturer operate a certified quality management system, the notified body shall take this into account in the surveillance.

- 4.4. Additionally the notified body may pay unexpected visits to the manufacturer. During such visits the notified body may carry out, or cause to

**▼B**

be carried out, tests to verify that the quality management system is functioning correctly, if necessary. The notified body must provide the manufacturer with a visit report and, if a test has taken place, with a test report.

5. Each notified body must communicate to the other notified bodies the relevant information concerning the quality management system approvals, issued, withdrawn or refused.

The other notified bodies may receive on request copies of the quality management system approvals issued.

6. The manufacturer must, for a period of 10 years after the last product has been manufactured, keep at the disposal of the national authorities:

- the documentation referenced to in the second indent of point 3.1,
- the updating referenced to in the second paragraph of point 3.4,
- the decisions and reports from the notified body in the final paragraph of points 3.4, 4.3 and 4.4.

7. The manufacturer or his authorised representative established within the Community must draw up the EC declaration of conformity of the interoperability constituent.

The content of this declaration shall include at least the information indicated in Annex IV (3) of Directives 96/48/EC or 01/16/EC. The EC declaration of conformity and the accompanying documents must be dated and signed.

The declaration must be written in the same language as the technical documentation and must contain the following:

- the Directive references (Directives 96/48/EC or 01/16/EC and other directives to which the interoperability constituent may be subject),
- the name and address of the manufacturer or his authorised representative established within the Community (give trade name and full address and in the case of an authorised representative also give the trade name of the manufacturer or constructor),
- description of the interoperability constituent (make, type, etc)
- description of the procedure (module) followed in order to declare conformity,
- all of the relevant descriptions met by the interoperability constituent and in particular any conditions of use,
- name and address of notified body (bodies) involved in the procedure followed in respect of conformity and date of certificates together with the duration and conditions of validity of the certificates,
- reference to the TSI and any other applicable TSI and where appropriate reference to European specification <sup>(1)</sup>,
- identification of the signatory empowered to enter into commitments on behalf of the manufacturer or of his authorised representative established within the Community.

The certificates to be referred to are:

- the quality management system approval indicated in point 3,
- the type-examination certificate and its additions,

8. The manufacturer or his authorised representative established within the Community must keep a copy of the EC declaration of conformity for a period of 10 years after the last interoperability constituent has been manufactured.

Where neither the manufacturer nor his authorised representative is established within the Community, the obligation to keep the technical documentation available is the responsibility of the person who places the interoperability constituent on the Community market.

<sup>(1)</sup> The definition of an European specification is indicated in the directives 96/48/EC and 01/16/EC. The guide for application of HS TSIs explains the way to use the European Specifications

**▼B**

9. If additional to the EC declaration of conformity an EC declaration of suitability for use for the interoperability constituent is requested in the TSI, this declaration has to be added, after being issued by the manufacturer under the conditions of Module V.

**4 MODULES FOR INTEROPERABILITY CONSTITUENTS****Module F: Product Verification**

1. This module describes the procedure whereby a manufacturer or his authorised representative established within the Community checks and attests that the interoperability constituent concerned and subject to the provisions of point 3 is in conformity with the type as described in the EC type examination certificate and satisfies the requirements of the TSI that apply to it.
2. The manufacturer must take all measures necessary in order that the manufacturing process ensures conformity of each interoperability constituents with the type as described in the type-examination certificate and with the requirements of the TSI that apply to it.
3. The notified body must carry out the appropriate examinations and tests in order to check the conformity of the interoperability constituent with the type as described in the EC type examination certificate and with the requirements of the TSI. The manufacturer <sup>(1)</sup> can choose either an examination and testing of every interoperability constituent as specified in point 4 or an examination and testing of interoperability constituents on a statistical basis, as specified in point 5.
4. Verification by examination and testing of every interoperability constituent
  - 4.1. Each product shall be individually examined and appropriate tests shall be carried out in order to verify the product conformity with the type as described in the type-examination certificate and with the requirements of the TSI that apply to it. When a test is not set out in the TSI, (or in an European Standard quoted in the TSI), the relevant European Specifications <sup>(2)</sup>, or equivalent tests are applicable.
  - 4.2. The notified body must draw up a written certificate of conformity for the approved products relating to the tests carried out.
  - 4.3. The manufacturer or his authorised representative must ensure that he is able to supply the notified body's certificates of conformity on request.
5. Statistical verification
  - 5.1. The manufacturer must present his interoperability constituents in the form of homogeneous lots and shall take all measures necessary in order that the manufacturing process ensures the homogeneity of each lot produced.
  - 5.2. All interoperability constituents must be available for verification in the form of homogeneous lots. A random sample shall be drawn from each lot. Each interoperability constituents in a sample shall be individually examined and appropriate tests shall be carried out to ensure the product conformity with the type as described in the type-examination certificate and with the requirements of the TSI which apply to it and to determine whether the lot is accepted or rejected. When a test is not set out in the TSI (or in an European Standard quoted in the TSI), the relevant European Specifications or equivalent tests are applicable.
  - 5.3. The statistical procedure must use appropriate elements (statistical method, sampling plan etc), depending on the characteristics to be assessed, as specified in the TSI.
  - 5.4. In the case of accepted lots, the notified body shall draw up a written certificate of conformity relating to the tests carried out. All interoperability constituents in the lot may be placed on the market except those

<sup>(1)</sup> The manufacturer's discretion may be limited in specific TSIs

<sup>(2)</sup> The definition of an European specification is indicated in the directives 96/48/EC and 01/16/EC. The guide for application of HS TSIs explains the way to use the European Specifications

**▼B**

interoperability constituents from the sample, which were found not to be in conformity.

If a lot is rejected, the notified body or the competent authority must take appropriate measures to prevent placing of that lot on the market. In the event of frequent rejection of lots the notified body may suspend the statistical verification.

- 5.5. The manufacturer or his authorised representative established within the Community must ensure that he is able to supply the notified body's certificates of conformity on request.
6. The manufacturer or his authorised representative established within the Community must draw up the EC declaration of conformity of the interoperability constituent.

The content of this declaration shall include at least the information indicated in Annex IV (3) of Directives 96/48/EC or 01/16/EC. The EC declaration of conformity and the accompanying documents must be dated and signed.

The declaration must be written in the same language as the technical documentation and must contain the following:

- the Directive references (Directives 96/48/EC or 01/16/EC and other directives to which the interoperability constituent may be subject),
- the name and address of the manufacturer or his authorised representative established within the Community (give trade name and full address and in the case of an authorised representative also give the trade name of the manufacturer or constructor),
- description of interoperability constituent (make, type, etc)
- description of the procedure (module) followed in order to declare conformity,
- all of the relevant descriptions met by the interoperability constituent and in particular any conditions of use,
- name and address of notified body (bodies) involved in the procedure followed in respect of conformity and date of certificates together with the duration and conditions of validity of the certificates,
- reference to the TSI and any other applicable TSI and where appropriate reference to European specifications,
- identification of the signatory empowered to enter into commitments on behalf of the manufacturer or of his authorised representative established within the Community.

The certificates to be referred to are:

- the type-examination certificate and its additions,
  - the certificate of conformity as mentioned in points 4 or 5.
7. The manufacturer or his authorised representative established within the Community must keep a copy of the EC declaration of conformity for a period of 10 years after the last interoperability constituent has been manufactured.

Where neither the manufacturer nor his authorised representative is established within the Community, the obligation to keep the technical documentation available is the responsibility of the person who places the interoperability constituent on the Community market.

8. If additional to the EC declaration of conformity an EC declaration of suitability for use for the interoperability constituent is requested in the TSI, this declaration has to be added, after being issued by the manufacturer under the conditions of Module V.

## **MODULES FOR INTEROPERABILITY CONSTITUENTS**

### **Module H 1: Full Quality Management System**

1. This module describes the procedure whereby the manufacturer or his authorised representative established within the Community who

**▼B**

satisfies the obligations of point 2, ensures and declares that the interoperability constituent concerned satisfies the requirements of the TSI that apply to it.

2. The manufacturer must operate an approved quality management system for design, production and final product inspection and testing as specified in point 3 and shall be subject to surveillance as specified in point 4.
3. Quality management system
- 3.1. The manufacturer must lodge an application for assessment of his quality management system with a notified body of his choice, for the interoperability constituents concerned.

The application must include:

- all relevant information for the product category representative for the interoperability constituent envisaged,
- the quality management system's documentation.
- a written declaration that the same application has not been lodged with any other notified body,

- 3.2. The quality management system must ensure compliance of the interoperability constituent with the requirements of the TSI that apply to it. All the elements, requirements and provisions adopted by the manufacturer must be documented in a systematic and orderly manner in the form of written policies, procedures and instructions. This quality management system documentation shall ensure a common understanding of the quality policies and procedures such as quality programmes, plans, manuals and records.

It must contain in particular an adequate description of:

- the quality objectives and the organisational structure,
- responsibilities and powers of the management with regard to design and product quality,
- the technical design specifications, including European specifications <sup>(1)</sup>, that will be applied, and, where the European specifications will not be applied in full, the means that will be used to ensure that the requirements of the TSI that apply to the interoperability constituent will be met,
- the design control and design verification techniques, processes and systematic actions that will be used when designing the interoperability constituents pertaining to the product category covered,
- the corresponding manufacturing, quality control and quality management system techniques, processes and systematic actions that will be used,
- the examinations, checks and tests that will be carried out before, during and after manufacture, and the frequency with which they will be undertaken,
- the quality records, such as inspection reports and test data, calibration data, qualification reports of the personnel concerned, etc.,
- the means to monitor the achievement of the required design and product quality and the effective operation of the quality management system.

The quality policies and procedures shall cover in particular the assessment phases as design review, review of manufacturing process and type tests, as they are specified in the TSI, for the different characteristics and performances of the interoperability constituent.

- 3.3. The notified body must assess the quality management system to determine whether it satisfies the requirements of point 3.2. It presumes compliance with these requirements if the manufacturer implements a quality system for design, production, final product inspection and testing in respect of the Standard EN/ISO 9001- 2000, which take into

<sup>(1)</sup> The definition of an European specification is indicated in the directives 96/48/EC and 01/16/EC. The guide for application of HS TSIs explains the way to use the European Specifications

**▼B**

consideration the specificity of the interoperability constituent for which it is implemented.

When the manufacturer operates a certified quality management system, the notified body shall take this into account in the assessment.

The audit must be specific for the product category, which is representative for the interoperability constituent. The auditing team must have at least one member experienced as an assessor in the product technology concerned. The evaluation procedure shall include an assessment visit to the manufacturer's premises.

The decision must be notified to the manufacturer. The notification must contain the conclusions of the examination and the reasoned assessment decision.

- 3.4. The manufacturer must undertake to fulfil the obligations arising out of the quality management system as approved and to uphold it so that it remains adequate and efficient.

The manufacturer or his authorised representative established within the Community shall keep the notified body that has approved the quality management system informed of any intended updating of the quality management system.

The notified body must evaluate the modifications proposed and decide whether the amended quality management system will still satisfy the requirements of point 3.2 or whether a re-assessment is required.

It must notify its decision to the manufacturer. The notification shall contain the conclusions of the evaluation and the reasoned assessment decision.

4. Surveillance of the quality management system under the responsibility of the notified body
- 4.1. The purpose of surveillance is to make sure that the manufacturer duly fulfils the obligations arising out of the approved quality management system.
- 4.2. The manufacturer must allow the notified body entrance for inspection purposes to the locations of design, manufacture, inspection and testing, and storage, and shall provide it with all necessary information, including particular:
- the quality management system documentation,
  - the quality records as foreseen by the design part of the quality management system, such as results of analyses, calculations, tests, etc.,
  - the quality records as foreseen by the manufacturing part of the quality management system, such as inspection reports and test data, calibration data, qualification reports of the personnel concerned, etc.
- 4.3. The notified body must periodically carry out audits to make sure that the manufacturer maintains and applies the quality management system and shall provide an audit report to the manufacturer. When the manufacturer operates a certified quality management system, the notified body shall take this into account in the surveillance. The frequency of the audits shall be at least once a year.
- 4.4. Additionally the notified body may pay unexpected visits to the manufacturer. At the time of such visits, the notified body may carry out tests or have them carried out in order to check the proper functioning of the quality management system where necessary. It must provide the manufacturer with a visit report and, if a test has been carried out, with a test report.
5. The manufacturer must, for a period of 10 years after the last product has been manufactured, keep at the disposal of the national authorities:
- the documentation referenced to in the second indent of the second subparagraph of point 3.1,
  - the updating referenced in the second subparagraph of point 3.4,
  - the decisions and reports from the notified body in the final subparagraph of points 3.4, 4.3 and 4.4.

**▼B**

6. Each notified body must communicate to the other notified bodies the relevant information concerning the quality management system approvals issued, withdrawn or refused.

The other notified bodies may receive on request copies of the quality management system approvals and additional approvals issued.

7. The manufacturer or its authorised representative established within the Community must draw up the EC Declaration of conformity of the interoperability constituent. The content of this declaration shall include at least the information indicated in Annex IV (3) of Directives 96/48/EC or 01/16/EC. The EC declaration of conformity and the accompanying documents must be dated and signed.

The declaration must be written in the same language as the technical documentation and must contain the following:

- the Directive references (Directives 96/48/EC or 01/16/EC and other directives to which the interoperability constituent may be subject)
- the name and address of the manufacturer or his authorised representative established within the Community (give trade name and full address and in the case of an authorised representative also give the trade name of the manufacturer or constructor),
- description of interoperability constituent (make, type, etc)
- description of the procedure (module) followed in order to declare conformity,
- all of the relevant descriptions met by the interoperability constituent and in particular its conditions of use,
- name and address of notified body (bodies) involved in the procedure followed in respect of conformity, and date of certificate together with the duration and conditions of validity of the certificate,
- reference to the TSI and to any other applicable TSI and where appropriate to European specifications,
- identification of the signatory empowered to enter into commitments on behalf of the manufacturer or of his authorised representative established within the Community.

The certificate to be referred to is:

- the Quality management system approvals indicated in point 3.

8. The manufacturer or his authorised representative established within the Community must keep a copy of the EC declaration of conformity for a period of 10 years after the last interoperability constituent has been manufactured.

Where neither the manufacturer nor his authorised representative is established within the Community, the obligation to keep the technical documentation available is the responsibility of the person who places the interoperability constituent on the Community market.

9. If additional to the EC declaration of conformity an EC declaration of suitability for use for the interoperability constituent is requested in the TSI, this declaration has to be added, after being issued by the manufacturer under the conditions of Module V.

## **MODULES FOR INTEROPERABILITY CONSTITUENTS**

### **Module H2: Full Quality Management System With Design Examination**

1. This module describes the procedure whereby a notified body carries out an examination of the design of an interoperability constituent and the manufacturer or his authorised representative established within the Community who satisfies the obligations of point 2 ensures and declares that the interoperability constituent concerned satisfies the requirements of the TSI that apply to it.
2. The manufacturer must operate an approved quality management system for design, production and final product inspection and testing as

**▼B**

specified in point 3 and shall be subject to surveillance as specified in point. 4.

3. Quality management system.
- 3.1. The manufacturer must lodge an application for assessment of his quality management system with a notified body of his choice, for the interoperability constituents concerned.

The application must include:

- all relevant information for the product category representative for the interoperability constituent envisaged,
- the quality management system's documentation.
- a written declaration that the same application has not been lodged with any other notified body,

- 3.2. The quality management system must ensure compliance of the interoperability constituent with the requirements of the TSI that apply to it. All the elements, requirements and provisions adopted by the manufacturer must be documented in a systematic and orderly manner in the form of written policies, procedures and instructions. This quality management system documentation shall ensure a common understanding of the quality policies and procedures such as quality programmes, plans, manuals and records.

It must contain in particular an adequate description of:

- the quality objectives and the organisational structure,
- responsibilities and powers of the management with regard to design and product quality,
- the technical design specifications, including European specifications <sup>(1)</sup>, that will be applied, and, where the European specifications will not be applied in full, the means that will be used to ensure that the requirements of the TSI that apply to the interoperability constituent will be met,
- the design control and design verification techniques, processes and systematic actions that will be used when designing the interoperability constituents pertaining to the product category covered,
- the corresponding manufacturing, quality control and quality management system techniques, processes and systematic actions that will be used,
- the examinations, checks and tests that will be carried out before, during and after manufacture, and the frequency with which they will be undertaken,
- the quality records, such as inspection reports and test data, calibration data, qualification reports of the personnel concerned, etc.,
- the means to monitor the achievement of the required design and product quality and the effective operation of the quality management system.

The quality policies and procedures shall cover in particular the assessment phases, such as design review, review of manufacturing processes and type tests, as they are specified in the TSI, for different characteristics and performances of the interoperability constituent.

- 3.3. The notified body must assess the quality management system to determine whether it satisfies the requirements of point 3.2. It presumes compliance with these requirements if the manufacturer implements a quality system for design, production, final product inspection and testing in respect of the Standard EN/ISO 9001- 2000, which takes into consideration the specificity of the interoperability constituent for which it is implemented.

When the manufacturer operates a certified quality management system, the notified body shall take this into account in the assessment.

<sup>(1)</sup> The definition of an European specification is indicated in the directives 96/48/EC and 01/16/EC. The guide for application of HS TSIs explains the way to use the European Specifications



**▼B**

The audit must be specific for the product category, which is representative for the interoperability constituent. The auditing team must have at least one member experienced as an assessor in the product technology concerned. The evaluation procedure shall include an assessment visit to the manufacturer's premises.

The decision must be notified to the manufacturer. The notification must contain the conclusions of the audit and the reasoned assessment decision.

- 3.4. The manufacturer must undertake to fulfil the obligations arising out of the quality management system as approved and to uphold it so that it remains adequate and efficient.

The manufacturer or his authorised representative established within the Community shall keep the notified body that has approved the quality management system informed of any intended updating of the quality management system.

The notified body must evaluate the modifications proposed and decide whether the amended quality management system will still satisfy the requirements of point 3.2 or whether a re-assessment is required.

It must notify its decision to the manufacturer. The notification shall contain the conclusions of the evaluation and the reasoned assessment decision.

4. Surveillance of the quality management system under the responsibility of the notified body

- 4.1. The purpose of surveillance is to make sure that the manufacturer duly fulfils the obligations arising out of the approved quality management system.

- 4.2. The manufacturer must allow the notified body entrance for inspection purposes to the locations of design, manufacture, inspection and testing, and storage, and shall provide it with all necessary information, including:

- the quality management system documentation,
- the quality records as foreseen by the design part of the quality management system, such as results of analyses, calculations, tests, etc.,
- the quality records as foreseen by the manufacturing part of the quality management system, such as inspection reports and test data, calibration data, qualification reports of the personnel concerned, etc.

- 4.3. The notified body must periodically carry out audits to make sure that the manufacturer maintains and applies the quality management system and shall provide an audit report to the manufacturer. When the manufacturer operates a certified quality management system, the notified body shall take this into account in the surveillance.

The frequency of the audits shall be at least once a year.

- 4.4. Additionally the notified body may pay unexpected visits to the manufacturer. At the time of such visits, the notified body may carry out tests or have them carried out in order to check the proper functioning of the quality management system where necessary. It must provide the manufacturer with a visit report and, if a test has been carried out, with a test report.

5. The manufacturer must, for a period of 10 years after the last product has been manufactured, keep at the disposal of the national authorities:

- the documentation referenced in the second indent of the second subparagraph of point 3.1,
- the updating referenced to in the second subparagraph of point 3.4,
- the decisions and reports from the notified body in the final subparagraph of points 3.4, 4.3 and 4.4.

6. Design examination

- 6.1. The manufacturer must lodge an application for examination of the design of the interoperability constituent with a notified body of his choice

**▼B**

- 6.2. The application must enable the design, manufacture, maintenance and operation of the interoperability constituent to be understood, and shall enable conformity with the requirements of the TSI to be assessed.

It must include:

- a general type-description,
  - the technical design specifications, including European specifications, with relevant clauses, that have been applied in full or in part,
  - any necessary supporting evidence for their adequacy, in particular where the European specifications and the relevant clauses have not been applied.,
  - the test programme
  - conditions for integration of the interoperability constituent in its system environment (sub-assembly, assembly, subsystem) and the necessary interface conditions,
  - conditions for use and maintenance of the interoperability constituent (restrictions of running time or distance, wear limits etc),
  - a written declaration that the same application has not been lodged with any other notified body,
- 6.3. The applicant shall present the results of tests <sup>(1)</sup>, including type tests when required, carried out by its appropriate laboratory or on their behalf.
- 6.4. The notified body must examine the application and assess the results of the tests. Where the design meets the provisions of the TSI that apply to it, the notified body must issue an EC design examination certificate to the applicant. The certificate shall contain the conclusions of the examination, conditions for its validity, the necessary data for identification of the approved design and, if relevant, a description of the product's functioning.

The time period of validity shall be no longer than 5 years.

- 6.5. The applicant must keep the notified body that has issued the EC design examination certificate informed of any modification to the approved design. Modifications to the approved design must receive additional approval from the notified body that issued the EC design examination certificate where such changes may affect the conformity with the requirements of the TSI or the prescribed conditions for use of the product. In this case, the notified body shall perform only those examinations and tests that are relevant and necessary to the changes. The additional approval shall be given in the form of an addition to the original EC design examination certificate.
- 6.6. If no modifications as in point 6.4. have been made, the validity of an expiring certificate can be extended for another period of validity. The applicant will apply for such a prolongation by a written confirmation that no such modifications have been made, and the notified body issues a prolongation for another period of validity as in point 6.3. if no contrary information exists. This procedure can be reiterated.

7. Each notified body must communicate to the other notified bodies the relevant information concerning the quality management system approvals and the EC design examination certificates, which it has issued, withdrawn or refused.

The other notified bodies may receive on request copies of:

- the quality management system approvals and additional approvals issued and
  - the EC design examination certificates and additions issued
8. The manufacturer or his authorised representative established within the Community must draw up the EC declaration of conformity of the interoperability constituent.

The content of this declaration shall include at least the information indicated in Annex IV (3) of Directives 96/48/EC or 01/16/EC. The

<sup>(1)</sup> The presentation of the results of the tests can be at the same time as the application or later.

**▼B**

EC declaration of conformity and its accompanying documents must be dated and signed.

The declaration must be written in the same language as the technical documentation and must contain the following:

- the Directive references (Directives 96/48/EC or 01/16/EC and other directives to which the interoperability constituent may be subject),
- the name and address of the manufacturer or his authorised representative established within the Community (give trade name and full address and in the case of an authorised representative also give the trade name of the manufacturer or constructor),
- description of interoperability constituent (make, type, etc)
- description of the procedure (module) followed in order to declare conformity,
- all of the relevant descriptions met by the interoperability constituent and in particular any conditions of use,
- name and address of notified body (bodies) involved in the procedure followed in respect of conformity and date of certificates together with the duration and conditions of validity of the certificates,
- reference to the TSI and any other applicable TSI and where appropriate to European specifications,
- identification of the signatory empowered to enter into commitments on behalf of the manufacturer or of his authorised representative established within the Community.

The certificates to be referred to are:

- the quality management system approval and surveillance reports indicated in point 3 and 4,
  - the EC design examination certificate and its additions.
9. The manufacturer or his authorised representative established within the Community must keep a copy of the EC declaration of conformity for a period of 10 years after the last interoperability constituent has been manufactured.

Where neither the manufacturer nor his authorised representative is established within the Community, the obligation to keep the technical documentation available is the responsibility of the person who places the interoperability constituent on the Community market.

10. If additional to the EC declaration of conformity an EC declaration of suitability for use for the interoperability constituent is requested in the TSI, this declaration has to be added, after being issued by the manufacturer under the conditions of Module V.

## MODULES FOR INTEROPERABILITY CONSTITUENTS

### Module V: Type-Validation By In Service Experience (Suitability For Use)

1. This module describes that part of the procedure by which a notified body ascertains and attests that a specimen, representative of the production envisaged, meets the provisions of the TSI that apply to it for suitability for use, by type validation as demonstrated through in service experience <sup>(1)</sup>.
2. The manufacturer, or his authorised representative established within the Community, must lodge the application for the type-validation by in service experience with a notified body of his choice.

The application must include:

- the name and address of the manufacturer and also, if the application is lodged by the authorised representative, his name and address,

<sup>(1)</sup> During the time of in service experience, the IC is not placed on the market and the manufacturer cannot supply it to the clients.

**▼B**

- a written declaration that the same application has not been lodged with any other notified body,
- the technical documentation, as described in point 3,
- the programme for validation by in service experience, as described in point 4,
- the name and address of the company(ies) (infrastructure managers and/or railway enterprises), with which the applicant has obtained an agreement to contribute to a suitability for use assessment by in service experience
  - by operating the interoperability constituent in service,
  - by monitoring the in service behaviour and
  - by issuing a report about in service experience,
- the name and the address of the company undertaking the maintenance of the interoperability constituent during the time period or running distance required for in service experience,
- an EC declaration of conformity for the interoperability constituent and,
  - if module B is required in the TSI, an EC type examination certificate,
  - if module H2 is required in the TSI, an EC design examination certificate.

The applicant must place at the disposal of the company(ies), undertaking the operation of the interoperability constituent in service a specimen or a sufficient number of specimens, representative of the production envisaged and hereinafter called 'type'. A type may cover several versions of the interoperability constituent provided that the differences between the versions are all covered by EC declarations of conformity and certificates as mentioned above.

The notified body may request further specimens if needed for carrying out the validation by in service experience to be put in service.

3. The technical documentation must enable the assessment of the product with the requirements of the TSI. The documentation must cover the operation of the interoperability constituent, and, as far as relevant for such assessment, cover also the design, manufacture and maintenance.

The technical documentation must contain

- a general type-description,
  - the technical specification, against which the performance and in service behaviour of the interoperability constituent is to be assessed (relevant TSI and/or European Specifications with relevant clauses),
  - conditions of integration of the interoperability constituent in its system environment (sub-assembly, assembly, subsystem) and the necessary interface conditions,
  - conditions for use and maintenance of the interoperability constituent (restrictions of running time or distance, wear limits etc),
  - descriptions and explanations necessary for the understanding of the design, manufacture and operation of the interoperability constituent;
- and, as far as is relevant for assessment,
- conceptual design and manufacturing drawings,
  - results of design calculations made and examinations carried out,
  - test reports.

If the TSI requires further information for the technical documentation, this shall be included. A list of the European specifications referenced to in the technical documentation, applied in full or in part, shall be attached.

**▼B**

4. The programme for the validation by in service experience must include:
  - the required performance or behaviour in service of the interoperability constituent under trial,
  - the installation arrangements,
  - the duration of the programme — either time or distance -
  - the operating conditions and the service programme expected,
  - the maintenance programme,
  - the special in service tests, if any, to be performed,
  - the batch size of the specimens — if more than one,
  - the inspection programme (nature, number and frequency of inspections, documentation),
  - criteria for tolerable defects and their impact on the programme,
  - the information to be included in the report of the company operating the interoperability constituent in service (see point 2).
5. The notified body must:
  - 5.1. Examine the technical documentation and the programme for validation by in service experience,
  - 5.2. Verify that the type is representative and has been manufactured in conformity with the technical documentation,
  - 5.3. Verify that the programme for validation by in service experience is well adapted to assess the required performance and in service behaviour of the interoperability constituent,
  - 5.4. Agree with the applicant the programme and the location where the inspections and necessary tests will be carried out and the body performing the tests (notified body or other competent laboratory),
  - 5.5. Monitor and inspect the progress of in service running, operation and maintenance of the interoperability constituent,
  - 5.6. Evaluate the report, to be issued by the company (ies) (infrastructure managers and/or railway enterprises) operating the interoperability constituent, and all other documentation and information, gained during the procedure (test reports, maintenance experience etc),
  - 5.7. Assess, if the in service behaviour meets the requirements of the TSI.
6. Where the type meets the provisions of the TSI, the notified body must issue a suitability for use certificate to the applicant. The certificate must contain the name and address of the manufacturer, conclusions of the validation, conditions for its validity and the necessary data for identification of the approved type.
 

The time period of validity shall be no longer than 5 years.

A list of the relevant parts of the technical documentation must be annexed to the certificate and a copy kept by the notified body.

If the applicant is denied a suitability for use certificate, the notified body must provide detailed reasons for such denial.

Provision must be made for an appeals procedure.
7. The applicant must inform the notified body that holds the technical documentation concerning the suitability for use certificate of all modifications to the approved product which must receive additional approval where such changes may affect the suitability for use or the prescribed conditions for use of the product. In this case, the notified body shall perform only those examinations and tests that are relevant and necessary to the changes. The additional approval may be given in the form of an addition to the original suitability for use certificate, or by issue of a new certificate issued after withdrawal of the old certificate.
8. If no modifications as in point 7 have been made, the validity of an expiring certificate can be extended for another period of validity. The applicant will apply for such a prolongation by a written confirmation that no such modifications have been made, and the notified body issues a

**▼B**

prolongation for another period of validity as in point 6, if no contrary information exists. This procedure can be reiterated.

9. Each notified body must communicate to the other notified bodies the relevant information concerning the suitability for use certificates issued, withdrawn or refused.
10. The other notified bodies shall be provided on request with copies of the suitability for use certificates issued and/or their additions. The annexes to the certificates must be kept at the disposal of the other notified bodies.
11. The manufacturer or his authorised representative established within the Community must draw up the EC declaration of suitability for use of the interoperability constituent.

The content of this declaration shall include at least the information, indicated in Annex IV (3) of Directives 96/48/EC or 01/16/EC.

The EC declaration of suitability for use and the accompanying documents must be dated and signed.

The declaration must be written in the same language as the technical documentation and must contain the following:

- the Directive references (Directives 96/48/EC or 01/16/EC),
  - the name and address of the manufacturer or his authorised representative established within the Community (give trade name and full address and in the case of an authorised representative also give the trade name of the manufacturer or constructor),
  - description of interoperability constituent (make, type, etc)
  - all of the relevant descriptions met by the interoperability constituent and in particular any conditions of use,
  - name and address of notified body (bodies) involved in the procedure followed in respect of suitability for use and date of suitability for use certificate together with the duration and conditions of validity of the certificate,
  - reference to this TSI and to any other applicable TSI, and where appropriate reference to European specification,
  - identification of the signatory empowered to enter into commitments on behalf of the manufacturer or of his authorised representative established within the Community.
12. The manufacturer or his authorised representative established within the Community must keep a copy of the EC declaration of suitability for use for a period of 10 years after the last interoperability constituent has been manufactured. Where neither the manufacturer nor his authorised representative is established within the Community, the obligation to keep the technical documentation available is the responsibility of the person who places the interoperability constituent on the Community market.

**▼B**

## ANNEX R

**VEHICLE TRACK INTERACTION AND GAUGING****Longitudinal compressive forces**

## R.1. TESTS CONDITIONS

## R.1.1. Track

The track for the tests shall consist in an S-format curve of  $R = 150\text{m}$ . Curves are separated by a section of straight track measuring  $6\text{m}$  in length.

Fig. R1

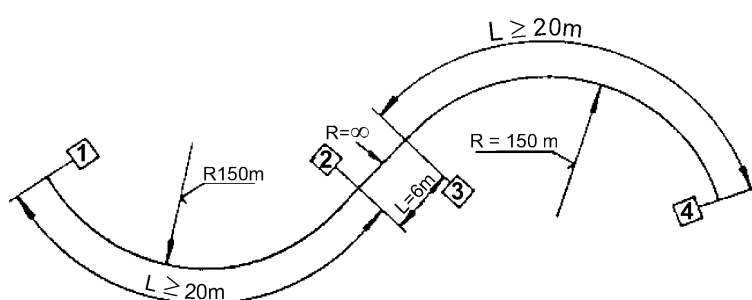

The track for the tests shall have - 0- cant. The average gauge is between  $1,450\text{-}1,465\text{ mm}$ .

## R.1.2. Test train

## — Standard configuration

Use of slave wagons with the following characteristics:

	Front wagon	Tail wagon
Type	Fcs or Tds	Rs
Length over buffer:	9,64 m	19,90 m
Wheelbase:	6,00 m	13,00 m

The fig. R2 is an example of a test train with the above-mentioned standard configurations.

The slave wagon must be laden (20tons axle load) and the test wagon shall be empty.

## — Complete configuration

By long two axles freight wagons with  $\text{LoB} \geq 15,75\text{ m}$  is a special test in a three wagon train configuration necessary (test wagon and two slave wagons with the same geometrical parameters).



Fig. R2

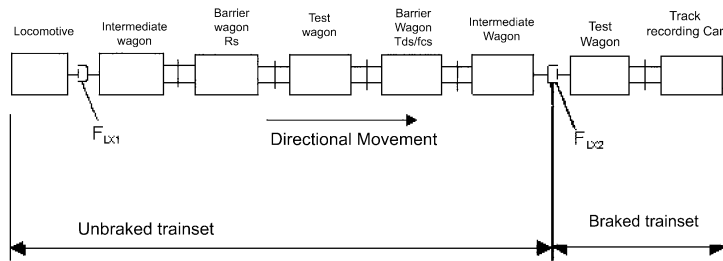

To calculate the longitudinal compressive force, use shall be made of 2 or 4 axle intermediate wagons fitted at one end with central-buffer coupling (incorporating a stress recorder) <sup>(1)</sup>.

### R.1.3. Buffer type

The slave wagons must be fitted with category A non-pivoting buffers (590kN end-stroke force) which have already been used in revenue service. The buffers on the slave wagons shall have spherical bearing surfaces of  $R = 1\,500$  mm. The test wagon shall be fitted with the same buffer type as the model to be used in its future operating.

When starting the tests, the buffer bearing surfaces shall show no signs of wear.

### R.1.4. Carrying out the tests

The screw couplers between the test wagon and the slave wagons are to be tightened in such a way that when on the straight track the buffer plates are in contact without pre-tensioning

The vertical offset of buffer centre-lines between the slave wagons and the test wagon will need to be approximately 80mm <sup>(2)</sup>.

The buffer plates shall have a low friction surface, such as lightly greased steel. Any building up of material as a result of scratches must be removed after each test. Buffer-plate pairs shall be replaced where, as a result of scratches or deformation, results obtained differ considerably from those already recorded.

The test train shall reverse back along an S-shaped curve at a speed of 4 to 8 km/h with a longitudinal compressive force that remains virtually constant. The longitudinal compressive force will steadily increase until one of the evaluation criteria mentioned under point 4 is reached or exceeded. Until 280 kN it will not reach any evaluation criteria and so does not need to be increased.

In order to determine the linear comparison, at least 20 tests shall be carried out for analysis, with different longitudinal compressive forces. On this occasion, the average longitudinal compressive force (2-axle goods wagons 200kN and bogie wagons 240kN) should be exceeded of about 10 % in at least 10 of the tests.

In the course of the 20 tests, at 5 consecutive tests of the longitudinal compressive force must be carried out without changing the buffers or buffer plates maintenance. According to point 4, no evaluation criterion shall be exceeded.

## R.2. SCOPE OF MEASUREMENTS

### R.2.1. Measurements during the tests

As a minimum, the following values shall be measured during the tests and recorded:

- Longitudinal Compressive Force  $F_{Lxi}$
- Wheel elevation  $d_{zij}$  of all wheels
- Lateral forces on axle-boxes  $H_{yj}$  of all wheels
- Deformation of axle guards  $d_{Aijy}$  of all wheels (of goods wagons fitted with axle guards only)
- Lateral movements  $dy_{p1}$ ,  $dy_{p2}$  of the buffers between the slave wagons and test wagon

<sup>(1)</sup> Other measuring systems giving the same results may also be used.

<sup>(2)</sup> Conditional type of construction tolerances are authorised.



▼ **B**

- Recording of track markers (Fig. R1)
- Distance covered (e.g. 1 m marker)

Fig. R3

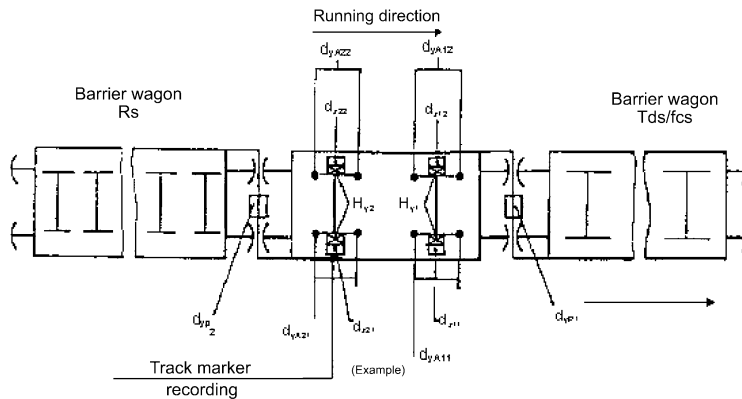
**R.2.2. Measurements/Calculations to be made**

- Measurement of the torsional stiffness ( $c_t^*$ ) of the slave wagons of the tested wagon.
- Measurement of the characteristic static curve on the buffers of the slave wagons and test wagon.
- Measurements of the track geometry before and after the tests
- Measurements of the lateral and longitudinal play between the axle box and axle guard on the test wagon before and after the tests
- Measurements of the buffer height above the rail top on the slave wagons and test wagon.

**R.3. EVALUATION CRITERIA USED TO CALCULATE THE PERMISSIBLE LONGITUDINAL COMPRESSIVE FORCE.**

- Evaluation of a non-guide wheel  $d_{zij} \geq 50$  mm over a distance of  $\geq 2$  m.
- Climbing of the guide wheel  $d_{zij} \geq 5$  mm for wheel load  $Q_{ij} < 0$ ; guide wheels are wheels 11 and 12 in 2 axle wagons. This criterion is to be checked in the case of the complete configuration of test trains (s. chapter R 1.2).
- Axle-guard deformation  $d_{yAij} \geq 22$  mm (1), measured 380 mm from the lower edge of the sole-bar.
- Stabilised track stress  $H_{lim}(2m) = 25 + 0,6 \times 2 \times Q_0$  (kN)  
 $Q_0$  = middle wheel force on rail
- Minimum horizontal overlap of buffer plates  $\geq 25$ mm.

**R.4. ANALYSIS**

For each test, it is necessary to calculate:

- $H_{y,i}$ ,  $D_{z,i,j}$  value over a distance of 2m
- $d_{zij}$  as a value of the climbing of the guide wheel. Analysis to be checked only with test trains in complete configuration (s. chapter R 1.2)
- $F_{LX}$
- $d_{yAij}$  (for 2-axle wagons with guards)
- $d_{yp}$

The values calculated shall be presented in graphic form as a function of the longitudinal compressive force  $F_{LX}$ .

In order to calculate the permissible longitudinal compressive force, the straight regression line equations shall be defined for the quantities to be measured  $d_{zij}$ ,  $d_{yAij}$  and  $H_{yi}$

**▼ B**

The permissible longitudinal compressive force shall be defined as the value found on the abscissa for the point of intersection between the straight regression line and the evaluation criterion (see fig. R4)

*Fig. R4*

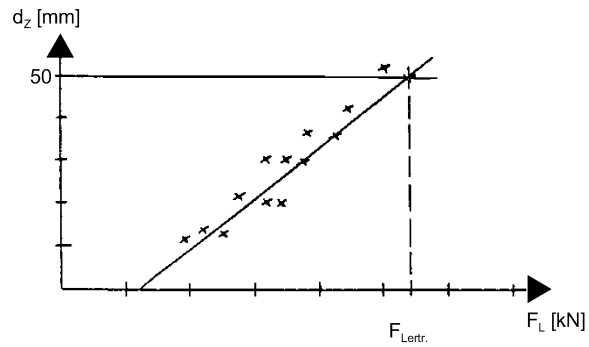

The evaluation criterion giving the lowest value for  $F_{Lert}$  shall determine the permissible longitudinal compressive forces. A report shall be drawn up, describing the tests carried out and presenting a summary of the most important data in table form.

▼ **B**

## R.5. CONDITIONS FOR TEST EXEMPTION

**2axle wagons:** in dependence of tare weight, length over buffers and torsional stiffness acc. the following diagram:

Fig. R5

Minimum tare of 2-axle long wagons with side buffers and screw-coupling

$14,1 \text{ m} \leq \text{Lob} \leq 15,5 \text{ m}$  and  $9 \text{ m} \leq 2a^* \leq 10 \text{ m}$   
 Longitudinal force  $F_L = 200 \text{ kN}$  and buffer plates  $R = 2750 \text{ mm}$

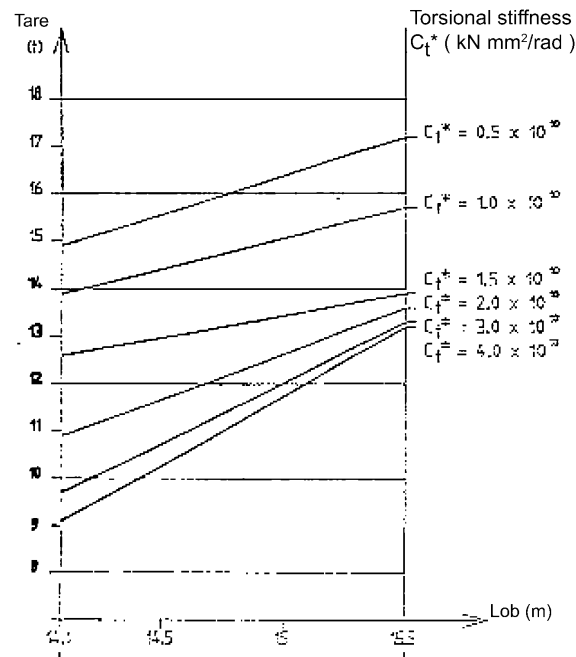
**4axle wagons:**

- tare weight  $\geq 16 \text{ t}$
- rate tare weight/LOB  $\geq 1,0 \text{ t/m}$
- length of overhang in accordance with the conditions in Fig. R6 for wagons with steering axle bogies and in Fig. R7 for wagons with bogie type Y25.

▼B

Fig. R 6

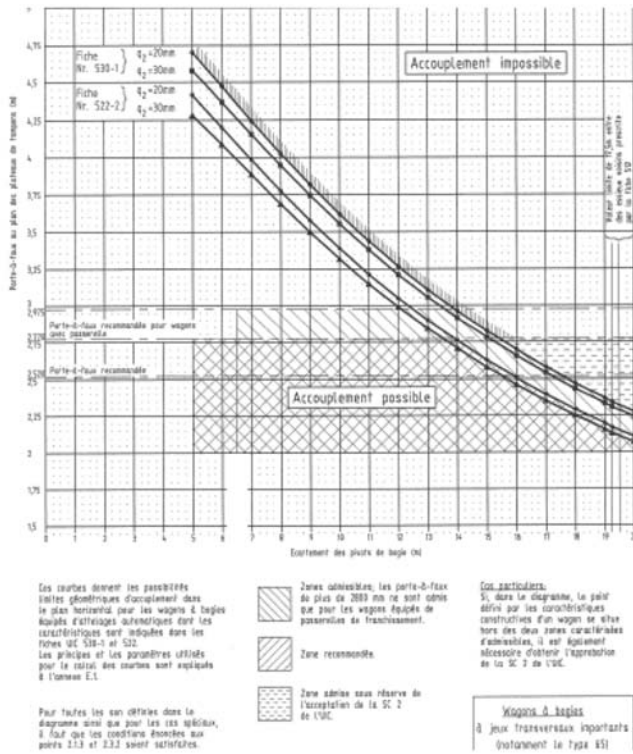
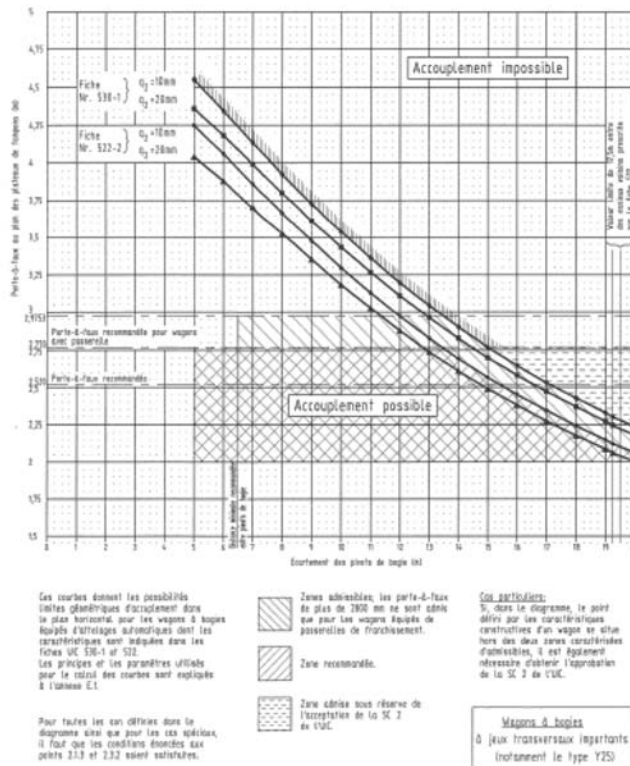

Fig. R 7



**▼B***ANNEX 5***BRAKING****Braking Performance**

- S.1. Determining the braking power of vehicles fitted with UIC air brake for passenger trains
  - S.1.1. General
    - S.1.2. Determining the braking power by calculation
      - S.1.2.1. Determining the braking power using the factor k
        - S.1.2.2. Wagons for which the required condition for calculating the braking power according to paragraph S.1.2.1 is not given.
    - S.1.3. Determining the braked mass in tests
      - S.1.3.1. Wagons with a maximum speed of  $\leq$  120 km/h
        - S.1.3.1.1. Tests on a single vehicle (slip brake tests)
          - S.1.3.1.2. Vehicle composition in the slip brake test
      - S.1.3.2. Wagons with a maximum speed greater than 120 km/h but not exceeding 160 km/h
- S.2. Determining the braking power of wagons fitted with a UIC air brake for freight trains
- S.3. Execution of tests
  - S.3.1. Method of execution for the tests
    - S.3.1.1. Atmospheric conditions
    - S.3.1.2. Number of tests
    - S.3.1.3. Condition of friction components and discs/wheels
  - S.3.2. Method of evaluating the test results
    - S.3.2.1. Correcting the braking distances from each test
      - S.3.2.2. Correcting the mean braking distance
- S.4. Evaluation of brake performance by a calculation
  - S.4.1. Step by step calculation
  - S.4.2. Calculation by stages of deceleration

**▼ B****S.1. DETERMINING THE BRAKING POWER OF VEHICLES FITTED WITH UIC AIR BRAKE FOR PASSENGER TRAINS.****S.1.1. General**

The braked mass marked on a wagon shall indicate the braking power of this wagon in a 500 m long train that is braked in the P position.

The braked mass of a train of wagons is in principle the sum of the braked mass painted on the vehicles with an active brake.

This braked mass applies to hauled rakes that are  $\leq 500$  m long and braked in the P position.

**S.1.2. Determining the braking power by calculation***S.1.2.1. Determining the braking power using the factor k*

The braked mass B of a wagon shall be determined by calculation providing the following conditions are met:

- maximum speed  $\leq 120$  km/h,
- the wheels are braked on both sides and have a nominal diameter of 920 to 1 000 mm,
- the brake shoes are made of P10 cast iron,
- the blocks are type Bg (single) or Bgu (tandem),
- force applied by the shoes 5 to 40 kN with Bg and 5 to 55 kN with Bgu blocks.

The braked mass shall be calculated using the following formula:

$$\text{Equation (S1): } B[t] = \frac{k[-] \times \sum F_{\text{dyn}} [\text{kN}]}{9,81 [\text{m/s}^2]}$$

where  $\sum F_{\text{dyn}}$  is the sum of all the forces applied by the shoes whilst the vehicle is moving and k is a dimensionless factor that depends on the type of shoe (Bg or Bgu) and on the contact force of each shoe.

$\sum F_{\text{dyn}}$  shall be calculated using the following formula:

$$\sum F_{\text{dyn}} = (F_t \times i - i^* \times F_R) \times \eta_{\text{dyn}}$$

Where:

$F_t$  = Effective force at the brake cylinder [kN], once the recoil of the cylinders and of the rigging has been deducted

i = Total increment for the brake rigging

$i^*$  = The increment after the central rigging (normally 4 for two-axled wagons and 8 for bogie wagons)

$\eta_{\text{dyn}}$  = Mean efficiency of the rigging whilst the vehicle is moving (mean between two maintenance visits).  $\eta_{\text{dyn}}$  can be up to 0,91, depending on the type of rigging.

$F_R$  = Opposing force applied from the regulator (usually 2 kN)

The 'k' curves used to calculate the braked mass are given by mathematical formulae of the following type:

$$\text{Equation (S2): } k = a_0 + a_1 \times F_{\text{dyn}} + a_2 \times F_{\text{dyn}}^2 + a_3 \times F_{\text{dyn}}^3$$

where:

	$a_0$	$a_1$	$a_2$	$a_3$
$k_{\text{Bg}}$	2,145	$-5,38 \times 10^{-2}$	$7,8 \times 10^{-4}$	$-5,36 \times 10^{-6}$
$k_{\text{Bgu}}$	2,137	$-5,14 \times 10^{-2}$	$8,32 \times 10^{-4}$	$-6,04 \times 10^{-6}$

**▼ B**

S.1.2.2. *Wagons for which the required condition for calculating the braking power according to paragraph S.1.2.1 is not given.*

The calculation method described below shall be used to design the brake equipment of wagons with a maximum speed of  $\leq 120$  km/h. The braked mass that is painted on the wagon shall be determined in tests.

The braked mass is usually calculated in the following two stages:

1. Calculation of the braking distance based on the braking power applied in the various speed ranges.
2. Determination of the braked mass percentage from the calculated braking distance using the assessment graph in Fig. S1 (wagon taken in isolation).

Fig.S1

**Assessment graph**

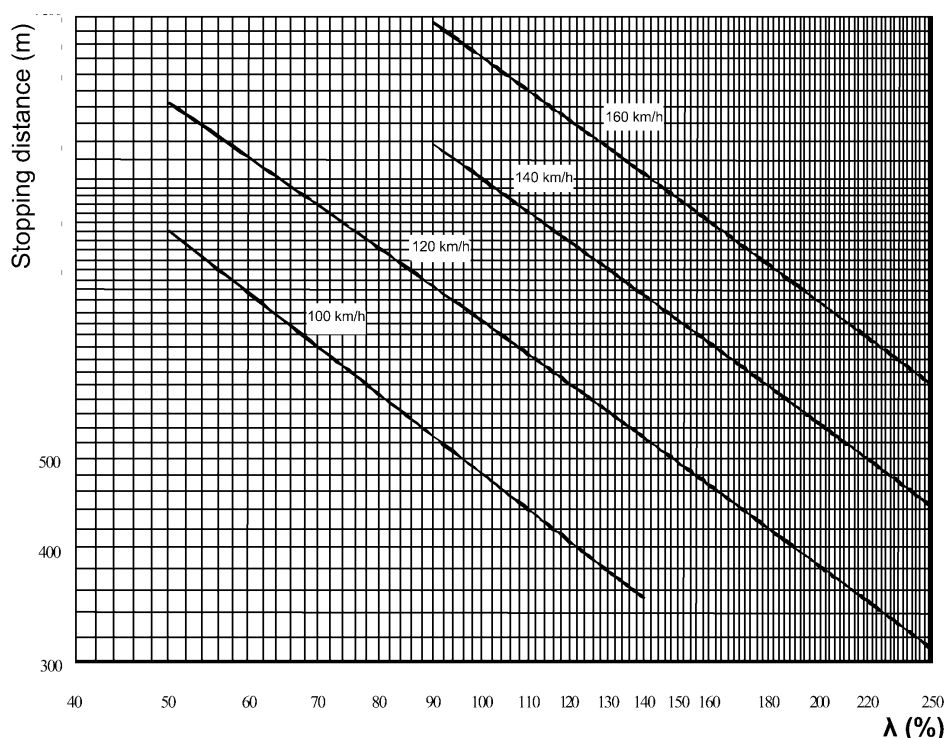

The braking distance shall be calculated step-by-step (chapter S.4.1) or by deceleration stages (chapter S.4.2)

The calculation methods that are indicated apply in principle to a single wagon.

The braking distance shall be calculated for each of the initial speeds given in chapter S.1.3.2 and for the load conditions in chapter S.1.3.2 taking into account:

- the average dynamic efficiency between two maintenance visits,
- a brake cylinder filling time of 4s,
- the lowest mean friction characteristic for the friction materials on this type of wagon.

Once the braking distances have been calculated the braked mass shall be pre-determined using the procedure from chapter S.1.3.2, but with the calculated braking distances instead of the mean braking distances measured in tests.

For wagons as described in chapter S.1.2.1 that have a maximum speed of 140 km/h, the braked mass calculated for 120 km/h (cf. chapter S.1.2.1) may also be used for the maximum speed of 140 km/h.

The braked mass may be pre-determined using this calculation procedure, taking into account the following additional points:

- The braking distance shall be calculated for braking from 100, 120, 140 and 160 km/h up to the maximum speed of the wagon;

**▼B**

- Once the braking distances have been calculated, the braked mass shall be pre-determined using the procedure from chapter S.1.3.2, but with the calculated braking distances instead of the mean braking distances measured in tests.

The braked mass that is painted on the wagon shall be determined in tests (chapter S.1.3).

**S.1.3. Determining the braked mass in tests**

This procedure shall be obligatory wherever there is no approved calculation method. The procedure may also be carried out for wagons as described in chapter S.1.2.1 (P10 shoes). If the tests give a braked mass that is higher than the calculated value then the calculated value shall not be changed; if the tests give a braked mass that is lower than the calculated value, the reason for that result shall be determined.

test may be carried out:

- tests with a single vehicle

In these tests the braking distance of the train or wagon shall be measured in an emergency brake application from  $v_0$  on straight and flat track. The braking distance shall be measured from the point where the emergency brake application was initiated.

**S.1.3.1. Wagons with a maximum speed of  $\leq 120$  km/h****S.1.3.1.1. Tests on a single vehicle (slip brake tests)**

The vehicle in question shall be coupled to a locomotive and accelerated up to a speed of  $v_0$ . Once that speed has been reached the mechanical coupler shall be uncoupled. An emergency brake application shall be made. The braking distance shall be measured from the point where the emergency brake application was initiated.

**S.1.3.1.2. Vehicle composition in the slip brake test**

- One wagon in the case of a basic bogie-wagon;
- A group of three wagons in the case of two-axle wagons;
- A group of two wagons in the case of articulated non-bogie wagons;
- A set of wagons that cannot be split in service.

The slip brake tests shall be carried out at 100 km/h and 120 km/h.

Where an 'empty-loaded' changeover device is present, slip brake tests shall be carried out:

- in the 'empty' position, around the transition load (providing this is possible with the vehicle type in question). In the case of an automatic 'empty-loaded' changeover device, the tests shall also be carried out in the 'empty' position around the transition load, but at a load that is far enough below the transition load for the automatic device to be stable in the 'empty' position;
- at maximum load, in the 'loaded' position.

In the case of vehicles with an automatic, continually operating load changeover device the slip brake tests shall be carried out:

- in the empty state (tare mass), in the 'empty' loading position, in order to check that the maximum  $\lambda$  value prescribed has not been exceeded
- with the maximum load (which shall give the maximum braked mass).
- Slip brake tests shall also be carried out to verify the braked mass at the point of maximum energy dissipation.

The general test conditions can be found in chapter S.3.1.

The measured distance shall be corrected for nominal test conditions ( $v_{o\text{ nom}}$ ) using the method given in chapter S.3.2.

From the mean braking distance  $s$  (mean of the permissible corrected values), the braked mass percentage of the vehicle shall be determined either from the 120 km/h and/or 100 km/h curves in fig. S1 or from the formula in table S1. The resulting minimum braked mass percentage shall be taken.



**▼ B**

Table S1

**Calculation of  $\lambda$** 

$$S = \frac{C}{\lambda + D}$$

$$S = \frac{C}{S} - D$$

V [km/h]	C	D
100	52 840	10
120	83 634	19
140	119 179	19
160	161 280	19

These formulae are valid inside the limits corresponding to the extremities of the curves in Fig. S1.

When the braked mass to be painted on the vehicle is determined in tests the test result shall be adjusted for the 'mean' dynamic efficiency between two maintenance visits (0,83 for wagons as described in chapter S.1.2.1).

With P10 shoes the braked mass shall be corrected for the dynamic power at the insert holder using the following method:

- a) Determine the efficiency of the brake rigging as accurately as possible whilst the vehicle is running in the test to determine  $\eta_{\text{dyn test}}$ .

Where this measurement has not been taken,  $\eta_{\text{dyn test}} = 0,91$  may be used for new wagons with conventional rigging.

For other vehicles where  $\eta_{\text{dyn test}}$  has not been measured the following may be used:

$$\eta_{\text{dyn test}} = \frac{1 + \eta_{\text{stat test}}}{2}$$

This formula may not be applied for  $\eta_{\text{stat test}}$  values of less than 0,6.  $\eta_{\text{dyn test}}$  shall never be higher than 0,91.

- b) With  $B_{\text{test}}$  as the braked mass per insert holder in the test, the equations (1) and (2) above may be used to determine  $F_{\text{dyn test}}$  either by directly reading off the value.

- c) The corrected dynamic power is as follows:

$$F_{\text{dyn corr}} = F_{\text{dyn test}} \times \frac{0,83}{\eta_{\text{dyn test}}}$$

- d) With this value for  $F_{\text{dyn corr}}$  the same tables may be used to determine the corrected braked mass per insert holder,  $B_{\text{corr}}$ .

#### S.1.3.2. *Wagons with a maximum speed greater than 120 km/h but not exceeding 160 km/h*

The method shall be identical to that set down in chapter S.1.3.1 with two additional series of tests, one from 140 km/h and the other from 160 km/h if the wagon is capable of running at 160 km/h.

The measured braking distances shall be corrected for the nominal test conditions ( $V_{\text{o nom}}$ ) using the method given in chapter S.3.2.

The corrected mean braking distances shall be used to determine 4 values for  $\lambda$  ( $\lambda_{100}$ ,  $\lambda_{120}$ ,  $\lambda_{140}$ ,  $\lambda_{160}$ ) from the curves in fig. S1 (or from the formulae for these curves — see table S1).

The minimum value shall be taken from  $\lambda_{100}$ ,  $\lambda_{120}$ ,  $\lambda_{140}$  and  $\lambda_{160}$ .

**▼ B****S.2. DETERMINING THE BRAKING POWER OF WAGONS FITTED WITH A UIC AIR BRAKE FOR FREIGHT TRAINS**

The braked mass of wagons in position G shall be deemed to be the same as the braked mass determined in position P.

There shall be no separate assessment of the braking power of wagons in position G.

**S.3. EXECUTION OF TESTS****S.3.1. Method of execution for the tests***S.3.1.1. Atmospheric conditions*

In order to avoid bad atmospheric conditions affecting the results the tests shall be carried out with minimum wind and dry rail.

*S.3.1.2. Number of tests*

At least 4 valid tests shall be carried out from which the mean shall then be calculated. All the braking distances obtained shall be corrected according to point 1 of chapter S.3.2.

The mean shall be accepted if it meets the following criteria, which shall be checked simultaneously:

Criterion 1:  $\frac{\text{Standard deviation of sample } (\sigma_n)}{\text{Mean of sample } (\bar{s})} \leq 3,0 \%$  and

1. Criterion 2:  $|\text{Extreme value } (s_e) - \text{mean}(\bar{s})| \leq 1,95 \times \sigma_n$

where  $s_e$  is the braking distance furthest from the mean.

If one of the two criteria is not met, then a supplementary test shall be carried out (rejecting the extreme value ' $s_e$ ' if criterion 2 is not met and  $n \geq 5$ ).

With the new values thus obtained, criteria 1 and 2 shall then be checked where:

$s_i$  = the braking distance measured in test 'i', after correction

$\bar{s}$  = the mean braking distance,

$n$  = the number of tests,

$\sigma_n$  = the standard deviation of the sample

and

$$\sigma_n = \sqrt{\frac{\sum |s_i - \bar{s}|^2}{n}}$$

The number of valid tests shall be at least 70 % of the total number of tests performed. The tests taken out in accordance with chapter S.3.2, Point 1b, shall not figure in the total number of tests.

If after a total of 10 tests, one of the two criteria is not met, the test series shall be interrupted and the braking system controlled. The test interruption shall be recorded in the test report.

*S.3.1.3. Condition of friction components and discs/wheels*

Before starting the tests the vehicle's friction components (brake pads/shoes) shall be run in up to at least 70 % coverage. Shorter braking distances are obtained with 3 to 5 mm wear on cast iron brake shoes. If the tests include braking to a standstill in wet conditions, the leading edge of the pad/shoe shall be run-in in the direction of rotation.

It is recommended that the tests be carried out on block-braked vehicles with wheels (either new or re-profiled) that have been run for at least 1 200 km.

It is recommended that the initial temperature of the discs/wheels be between 50 °C and 60 °C.

**▼ B****S.3.2. Method of evaluating the test results****S.3.2.1. Correcting the braking distances from each test**

The braking distance obtained in test 'j' shall be corrected to take into account the following factors:

- nominal speed in relation to the initial speed measured in the test;
- gradient of the test track.

The correction shall be made by applying the following formula:

$$\frac{V_{jnom}^2}{2 \times 3,6^2 \times s_{jcorr}} = \frac{V_{jmeas}^2}{2 \times 3,6^2 \times s_{jmeas}} - \frac{g}{\rho} \times \frac{i}{1000}$$

Transformation gives the following:

$$s_{jcorr} = \frac{3,933 \times \rho \times v_{jnom}^2}{3,933 \times \rho \times v_{jmeas}^2 - i \times s_{jmeas}} \times s_{jmeas}$$

where:

- $s_{jcorr}$  [m] = corrected braking distance (which corresponds to the nominal speed in test j);
- $s_{jmeas}$  [m] = braking distance measured in test j;
- $v_{jnom}$  [km/h] = nominal initial speed in test j;
- $v_{jmeas}$  [km/h] = initial speed measured in test j;
- $\rho$  = coefficient of inertia of the 'rotating masses', which is defined as follows:

$$\rho = 1 + \frac{m_r}{m}$$

where:

- $m$  = mass of the test train or vehicle,
- $m_r$  = equivalent mass of the rotating components.

(Where no exact value is known  $\rho = 1,15$  for locomotives and  $\rho = 1,04$  for coaches shall be used.);

- $i$  [mm/m] = mean gradient over  $s_{jmeas}$  on the test track, which is positive (+) for an upgrade and negative (-) for a downgrade.

The following two criteria shall be verified to validate the test:

- a) 3 mm/m (5 mm/m in exceptional cases)

and

- b)  $v_{jmeas} - v_{jnom} \leq 4$  km/h

**S.3.2.2. Correcting the mean braking distance  $\bar{s}$** 

The mean braking distance  $\bar{s}$ , obtained in accordance with chapter S.3.1, shall be corrected to take into account the following factors:

- a) Dynamic efficiency of the brake rigging tested as compared with the mean in-service value and, for disc brakes, the mean wheel diameter on the vehicles tested as compared to the diameter of the half-worn wheel. For wagons with P10 block brakes and conventional brake rigging the dynamic efficiency shall be corrected using the method set out in S.1.3.1.

The mean braking distance shall be corrected using the following formulae:

$$F_{corr} = F_{test} \times \frac{\eta_m}{\eta_{test}} \times \frac{d_{test}}{d_m}$$

and

**▼ B**

$$\bar{s}_{\text{corr}} = t_e \times v_{\text{nom}} + \frac{F_{\text{test}} + W_m}{F_{\text{corr}} + W_m} \times \{\bar{s} - v_{\text{nom}} \times t_e\}$$

where:

- $\bar{s}_{\text{corr}}$  [m] = corrected mean braking distance;
- $\bar{s}$  [m] = mean braking distance in the test;
- $t_e$  [s] = equivalent build-up time for the braking power;
- $V_{\text{nom}}$  [m/s] = nominal initial speed in the test;
- $d_{\text{test}}$  [mm] = mean wheel diameter on the vehicles tested;
- $d_m$  [mm] = diameter of the half-worn wheel;
- $F_{\text{corr}}$  [kN] = corrected braking power;
- $F_{\text{test}}$  [kN] = mean braking power in the test;
- $\eta_M$  = efficiency of the brake rigging in average service conditions;
- $\eta_{\text{test}}$  = efficiency of the brake rigging in the test;
- $W_m$  [kN] = mean resistance to forward motion.

- b) Real filling time in relation to the nominal 4s. This correction shall only be applied to tests with a vehicle taken in isolation.

The following correction formula shall be applied:

$$\bar{s}_{\text{corr}} = \left(2 - \frac{t_s}{2}\right) \times V_{\text{nom}} + \bar{S}$$

where:

- $\bar{s}_{\text{corr}}$  [m] = corrected mean braking distance;
- $\bar{s}$  [m] = mean braking distance;
- $t_s$  [s] = measured mean filling time for the brake cylinders;
- $V_{\text{nom}}$  [m/s] = nominal initial speed in the tests.

#### S.4. EVALUATION OF BRAKE PERFORMANCE BY A CALCULATION

##### S.4.1. Step by step calculation

The stop distance calculation can be performed step by step starting with general method based on dynamic equation; the algorithm is defined as follows:

**Step 1:** 
$$\sum F_i + W_i = m_e \times a_i$$

with:

- $\sum F_i$  sum of retarding forces of all active brakes
- $W_i$  retarding resistance at time i ;
- $m_e$  Equivalent vehicle mass (including rotating masses);
- $a_i$  Deceleration at time i.

**Step 2:** 
$$a_i = \frac{\sum F_i + W_i}{m_e}$$

**Step 3:** 
$$v_{i+1} = v_i - a_i \times \Delta t$$

with:

- $\Delta t$  Time calculation interval ( $\Delta t \leq 1s$ );

**▼ B**

$v_i$  initial speed of interval  $\Delta t$ ;

$v_{i+1}$  final speed of interval  $\Delta t$ ;

$$\text{Step 4:} \quad v_{mi} = \frac{v_i + v_{i+1}}{2}$$

with

$v_{mi}$  mean speed in time interval  $\Delta t$ .

$$\text{Step 5:} \quad \Delta s_i = v_{mi} \times \Delta t$$

with:

$\Delta s_i$  running distance during interval  $\Delta t$ .

The distance  $\Delta s_i$  may be also calculated with one of the following formula:

$$\text{Step 5bis:} \quad \Delta s_j = v_j \times \Delta t - \frac{1}{2} \times a_i \times \Delta t^2$$

$$\text{Step 5ter:} \quad \Delta s_j = \frac{v_i^2 - v_{i+1}^2}{2 \times a_i}$$

On the hypothesis where the brake force is constant on the interval, all the formulas give the same result.

$$\text{Step 6:} \quad s = \sum (v_{mi} \times \Delta t)$$

With:

$s$  total stopping distance (down to  $v = 0$ )

#### S.4.2. Calculation by stages of deceleration

In the cases when the vehicles are equipped with brakes which established retarding forces are constant by stages in some speed intervals or if one know the mean of this force, the following simplified method is possible:

$$\text{Step 1:} \quad a_{mi} = \frac{\sum F_{mi} + W_{mi}}{m_e}$$

with:

$F_{mi}$ ,  $W_{mi}$  and  $a_{mi}$  constant values or mean in the speed interval  $v_i$  à  $v_{i+1}$ .

$$\text{Step 2:} \quad \Delta s_j = \frac{v_i^2 - v_{i+1}^2}{2a_{mi}}$$

With:

$\Delta s_i$  running distance in this speed interval

$$\text{Step 3:} \quad s = t_e \times v_o + \sum \Delta s_i$$

*ANNEX T***SPECIFIC CASES****Kinematic gauge****Great Britain**

- T.1. WAGONS INTENDED TO RUN ON BRITISH LINES
  - T.1.1. Introduction
  - T.1.2. Section A — Gauge applicable to wagons in Great Britain (W6)
  - T.1.3. Section B — Sample Calculation for a W6-A Gauge Vehicle
  - T.1.4. Section C — W7 and W8 Gauges
  - T.1.5. Section D — Special load gauge W9
- T.1. WAGONS INTENDED TO RUN ON THE BRITISH NETWORK

**T.1.1. Introduction**

The following freight wagon gauges are available on lines in Great Britain: W6, W7, W8 and W9. The Infrastructure Manager shall list in the Infrastructure Register which gauge is available on a line. The gauges are described below in Section A –W6, Section B — Sample Calculation, Section C — W7 and W8, Section D — W9. Application of these gauges is limited to vehicles whose lateral suspension movement and sway is minimal. Vehicles with soft lateral suspension and/or large sway shall be evaluated dynamically according to Notified National Standards.

Below 400 mm ARL, wagons shall comply with both reference profile and G1 and W6, taking whichever profile is more limiting in size.

▼ B

## T.1.2. Section A — Gauge applicable to wagons in Great Britain (W6)

Figure T1

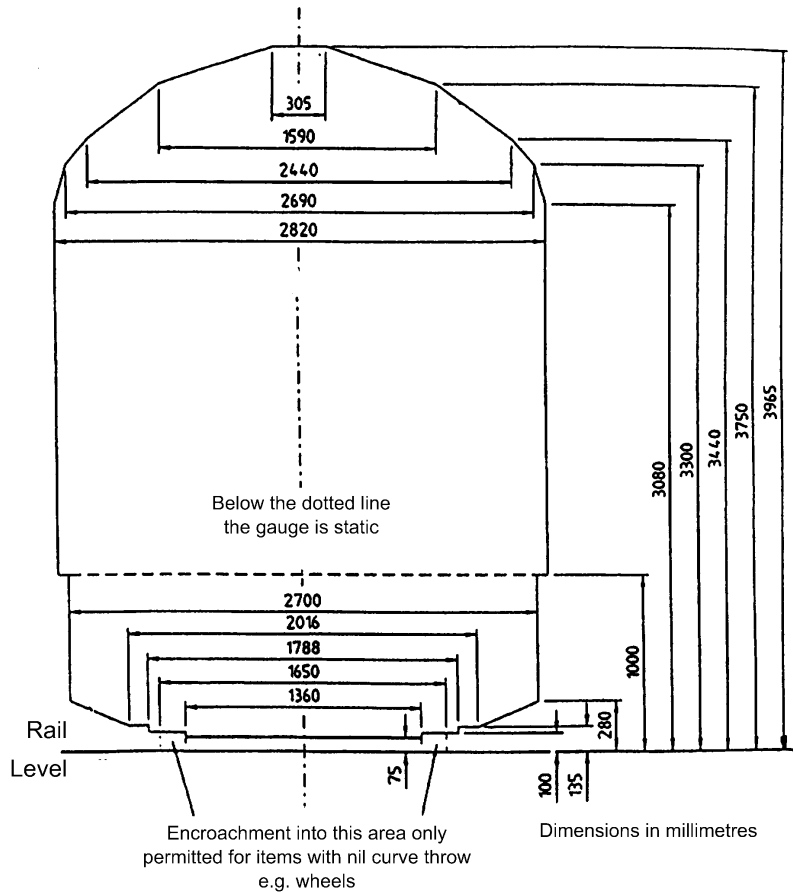

**Note on the reduction formulae and other factors to be considered when applying the W6 gauge to freight rolling stock**

#### Area above 1 000 mm Above Rail Level (ARL)

##### General

This part of the gauge is to be considered static and the gauge width is unaffected by any lateral movements.

##### 1 000 mm Dimension ARL

The 1 000 mm ARL dimension is an absolute minimum; no part of the wagon shall encroach vertically below this value such that the gauge is fouled, under whatever condition of loading or wear. Vertical spring travel shall be determined as the extreme movement to solid, or springstop condition.

##### Determination of Maximum Vehicle Width.

The 2 820 mm dimension on straight track (equivalent to 3 024 mm on curves with 200 m radius) is allowed without application of the width reduction formulae.

Diagram for Width Reduction Formulae.

**▼ B**

Figure T2

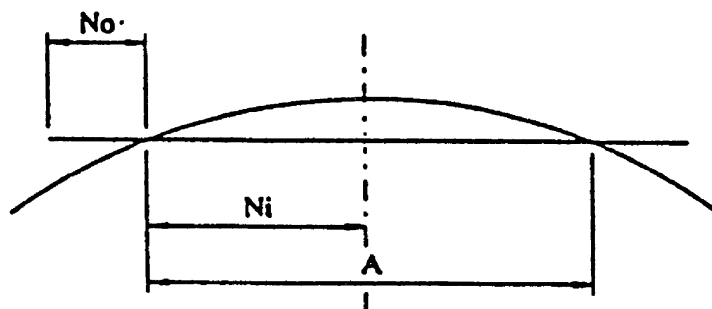

A = wheelbase/bogie centres in metres.

$N_i$  and  $N_o$  = distance in metres from the section in question to the nearest axle or bogie centre.

*Formulae to be applied for determination of the reduction above 1 000 ARL.*

a) Reduction  $E_i$  (metres) to be made on each side of the gauge at a section between axles/bogies:

$$E_i = \frac{AN_i - N_i^2}{400} - 0,102$$

b) Reduction  $E_o$  ( $E_o$  in metres to be made on each side of the gauge at a section situated beyond the axles or bogie centre:

$$E_o = \frac{AN_o + N_o^2}{400} - 0,102$$

*Note*

- A negative value calculated from a) or b) above indicates that the reduction to be applied is nil.
- No reduction is necessary at the centre of the vehicle unless the distance between bogie centres exceeds 12,8 m.
- The width reduction formulae apply equally to all width co-ordinates of the upper profile.
- No increase in the width of this gauge is permitted even if the displacements on the curve are less than described above.

**Area below 1 000 mm ARL****General**

This part of the gauge is simplified kinematic.

Due account shall be taken of all lateral displacements, however caused, i.e.:

- (a) full lateral suspension travel,
- (b) full lateral suspension wear,
- (c) curve throw ( $E_i$  or  $E_o$ ).

The following shall not be included:

- (d) vehicle roll,
- (e) axleguard deflection,
- (f) wheel flange to rail clearance,
- (g) wheel flange and rail wear.



**▼ B**

All underclearance values shown are an absolute minimum; no part of the wagon must encroach vertically downwards such that the gauge is infringed under whatever condition of loading or wear. Vertical spring travel must be determined as the extreme movement to solid, or springstop condition.

Additionally, under the foregoing conditions of full vertical deflection and wear, the vehicle must not infringe the gauge underclearances, relative to the 75, 100 and 135 mm ARL planes, when standing on a concave or convex vertical curve of 500 m radius.

#### Determination of Maximum Vehicle Width

At any point of the vehicle, the combination of its:

- (1) maximum static width, plus
- (2) the sum of values derived from 1.2.1 a), b) and c),

shall not exceed any one of the four values shown below:

Curve radius (R)	Maximum Width (1) + (2)
Straight (*)	2 700 mm
360 m	2 700 mm
200 m	2 820 mm
160 m	2 900 mm

(\*) Included to encompass those components not subject to curve throw, e.g. axleboxes.

#### Diagram for Width Reduction Formulae

**Figure T3**

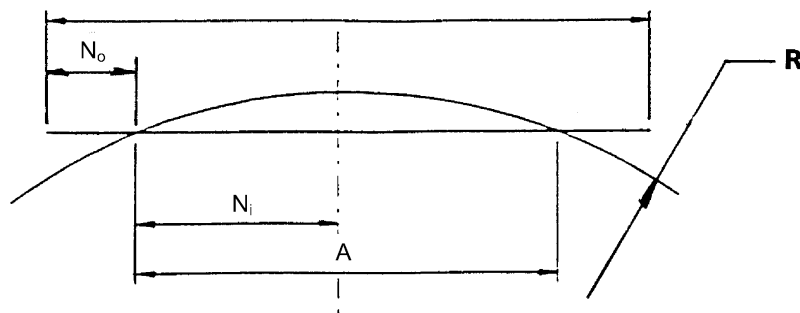

A = wheelbase/bogie centres in metres.

$N_i$  and  $N_o$  = distances in metres from the section in question to the nearest axle or bogie centre

R = curve radius

#### Formulae to be applied for determination of the reduction below 1 000 ARL

- a) Reduction  $E_i$  (metres) to be applied on each side of the gauge at a section between axles/or bogie centres.

$$E_i = \frac{AN_i - N_i^2}{2R}$$

**▼ B**

- b) Reduction  $E_o$  (metres) to be made on each side of the gauge at a section situated beyond the axles or bogie centres.

$$E_i = \frac{AN_o + N_o^2}{R}$$

Notes:

- Any width reduction derived from the above applies equally to all width co-ordinates of the lower profile.
- No increase in the width of this gauge is permitted.

### T.1.3. Section B — Sample Calculation for a W6-A Gauge Vehicle

#### 1. Example

- 1.1. Two-axle covered wagon, to the following dimensions:

Wheelbase (A)	9 m
Length over headstocks	12,82 m
Full lateral suspension travel	± 0,02 m
Full lateral suspension interface wear	0,003 m

- 1.2. Area above 1 000 mm ARL

- 1.2.1. At centre of the vehicle

$$E_i = \frac{AN_i - N_i^2}{400}$$

$$E_i = -0,051 \text{ m}$$

$E_i$  is calculated as a negative value, hence no reduction is necessary.

- 1.3. At vehicle headstock

- 1.3.1.

$$E_i = \frac{AN_o + N_o^2}{400} - 0,102$$

$$E_o = -0,05 \text{ m}$$

$E_o$  is calculated as a negative value, hence no reduction is necessary.

- 1.4. Area below 1 000 m ARL

- 1.4.1. Total lateral suspension movements

- 1.4.1.1.  $(0,020 + 0,003) \text{ m} = 23 \text{ mm}$  (half-width reduction)

- 1.5. At axle centre line

- 1.5.1.  $E_o/E_i = \text{zero}$

Therefore maximum width over axlebox components is:

$$2\,700 - 2(23) = 2\,654 \text{ mm}$$

- 1.6. At centre of the vehicle

- 1.6.1.

$$E_i = \frac{AN_i - N_i^2}{R}$$

- (i) for  $R = 360 \text{ m}$        $E_i = 28 \text{ mm}$

Therefore maximum width at  $R = 360 \text{ m}$ :

$$2\,700 - 2(23) - 2(28) = 2\,598 \text{ mm}$$

- (ii) for  $R = 200 \text{ m}$        $E_i = 51 \text{ mm}$

Therefore maximum width at  $R = 200 \text{ m}$ :

$$2\,820 - 2(23) - 2(51) = 2\,672 \text{ mm}$$

**▼ B**

- (iii) for R = 160 m                      E
- <sub>i</sub>
- 63 mm

Therefore maximum width at R = 160 m:

$$2\,900 - 2(23) - 2(63) = 2\,728 \text{ mm}$$

From the above it can be seen that case (i) produces the minimum value, and therefore the maximum permissible width at the centre of the vehicle is thus 2 598 mm.

## 1.7. At vehicle headstock

## 1.7.1.

$$E_i = \frac{AN_o + N_o^2}{R}$$

- (i) for R = 360 mm                      E
- <sub>o</sub>
- = 29 mm

Therefore maximum width at R = 360 mm:

$$2\,700 - 2(23) - 2(29) = 2\,596 \text{ mm}$$

- (ii) for R = 200 m                      E
- <sub>o</sub>
- = 52 mm

Therefore maximum width at R = 200 m:

$$2\,820 - 2(23) - 2(52) = 2\,670 \text{ mm}$$

- (iii) For R = 160 m                      E
- <sub>o</sub>
- = 65 mm

Therefore maximum width at R = 160 m:

$$2\,900 - 2(23) - 2(65) = 2\,724 \text{ mm}$$

From the above it can be seen that case (i) produces the minimum value, and therefore the maximum permissible width at the vehicle headstock is thus 2 596 mm.

## 3. Calculation of Vertical Displacements/Underclearances

## 3.1. Sprung Component Displacement

## 3.1.1.

- |                                       |         |
|---------------------------------------|---------|
| a) Allowable wheel wear               | 38,0 mm |
| b) Hollow tread                       | 6,0 mm  |
| c) spring, tare vehicle to springstop | 98,5 mm |

**Total: 142,5 mm (en pratique 143 mm)**

*Note:* This displacement can be reduced by the total thickness of one axle box cone-block packing assembly fitted to compensate for wheel wear, on vehicles which have the facility to accept cone block packings.

## 3.2. Unsprung Component Displacement

## 3.2.1.

- |                             |       |       |
|-----------------------------|-------|-------|
| d) (a) allowable wheel wear | 38 mm | 38 mm |
| e) (b) hollow tread         | 6 mm  | 6 mm  |

**Total: 44 mm**

## 3.2.2.

## 3.3. Underclearances, at Centre of the Vehicle

## 3.3.1.

The vertical displacement H<sub>i</sub> of a vehicle standing on a 500 m radius convex vertical curve, is given by the formula:

$$H_i = \frac{AN_i - N_i^2}{R}$$

$$H_i = 20 \text{ mm.}$$

## 3.4. Underclearances, at Vehicle Headstock

**▼B**

3.4.1.

The vertical displacement  $H_o$  of a vehicle standing on a 500 m radius concave vertical curve, given by the formula:

$$H_o = \frac{AN_o + N_o^2}{R}$$

$$H_o = 21 \text{ mm}$$

3.4.2.

*Note:* Values obtained as described in Clause 3.3 and 3.4 above are additional, for the 75, 100 and 135 mm ARL planes only, to those calculated in Clause 3.1 and 3.2 above.

**T.1.4. Section C — W7 and W8 Gauges**

**W7 Gauge**

*Fig. T4*

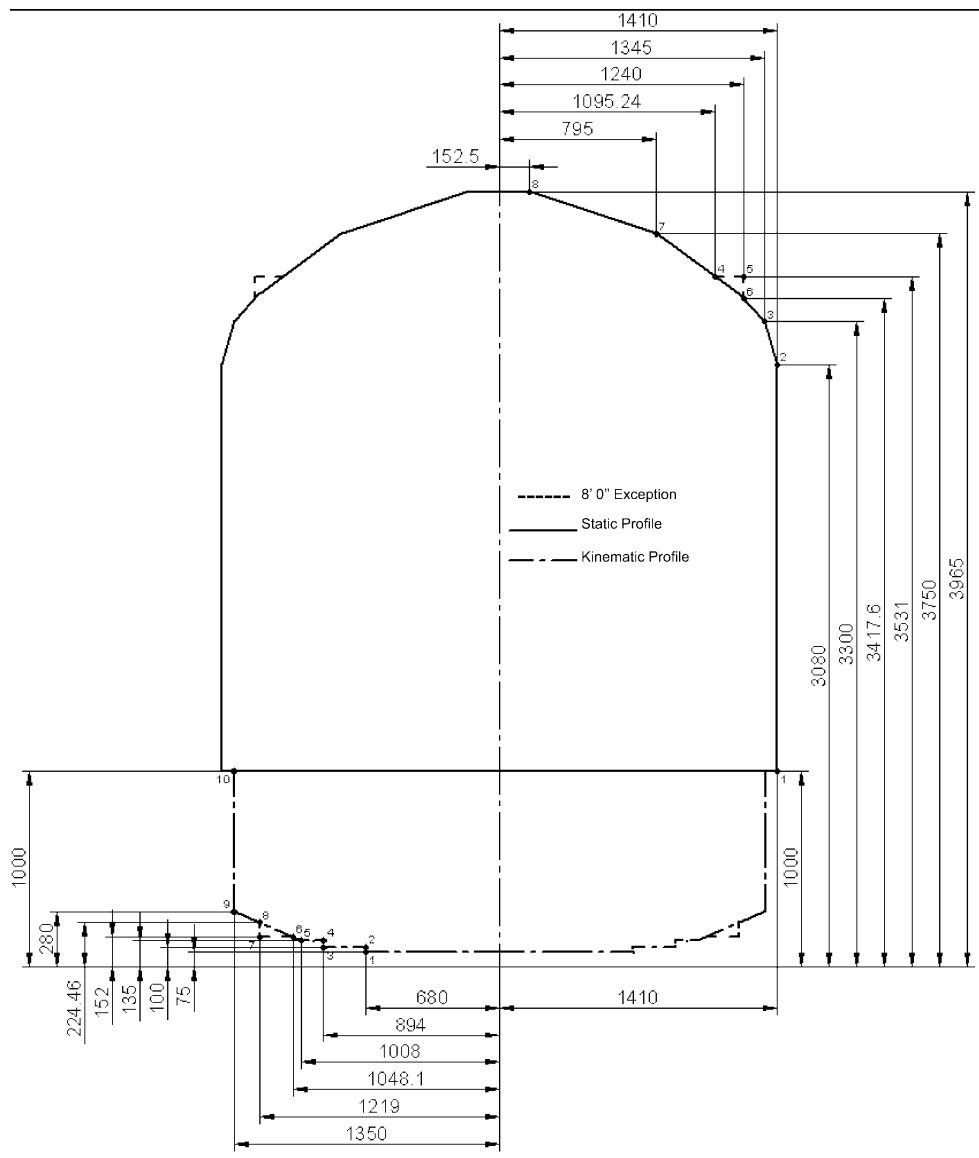

▼B

**W8 Gauge**

*Fig. T5*

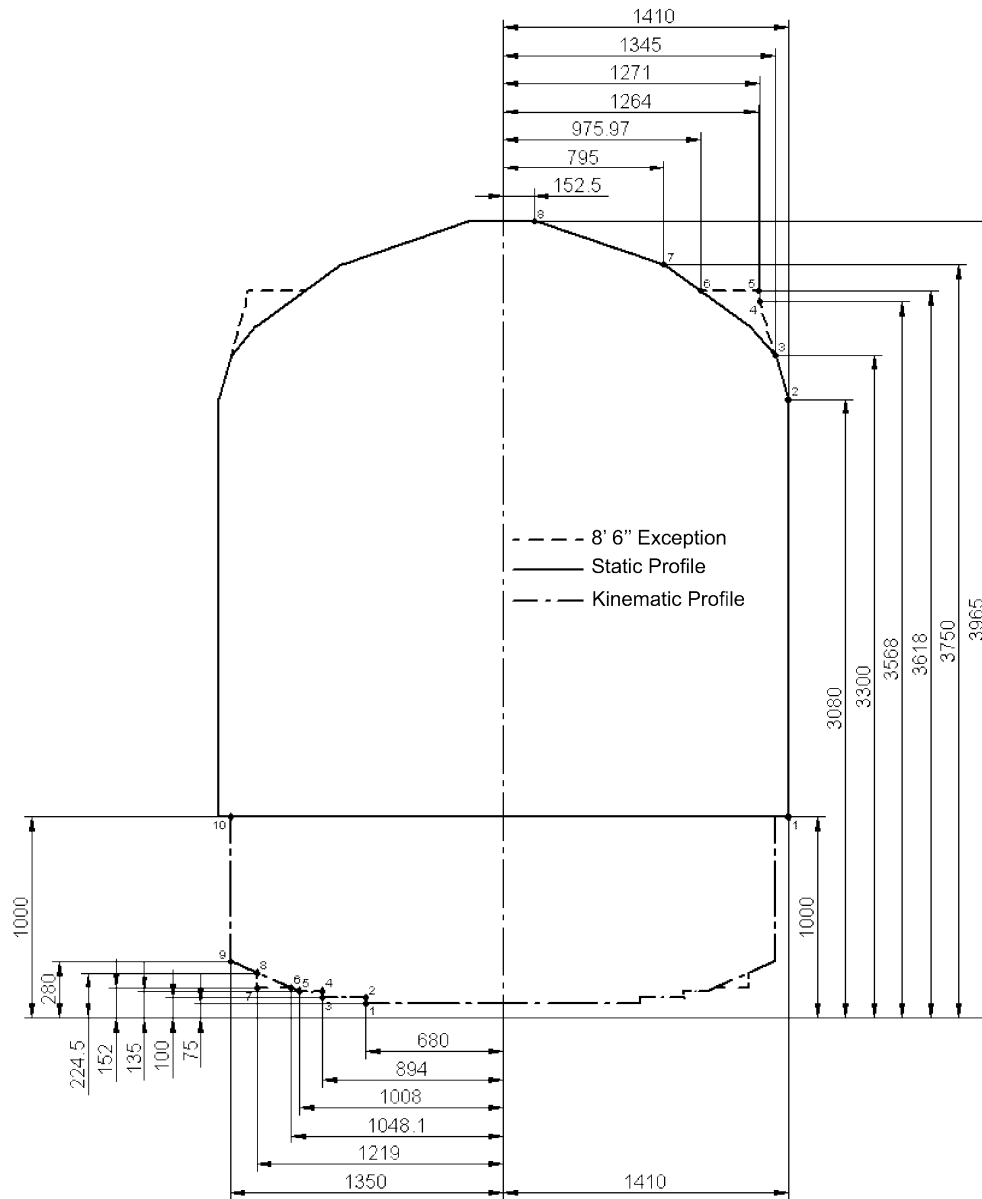

**T.1.5. Section D — Special load gauge W9**

— The wagon body and bogies shall be designed in accordance with the W6 gauge.

— When loaded onto a wagon, a demountable load shall comply with the W9 gauge described below.

1.1. The W9 gauge has two distinct parts that shall both be complied with:

W9 (i), this applies to load units situated between the bogie centres. [NB (i) denotes 'inner'].

W9 (o), this applies to load units situated on the wagon overhang i.e., between end bogie and the corresponding usable end of the wagon loading plane. [NB (o) denotes 'outer'].

▼B

Reference profile of the gauge W9 (i) inner

Fig. T6

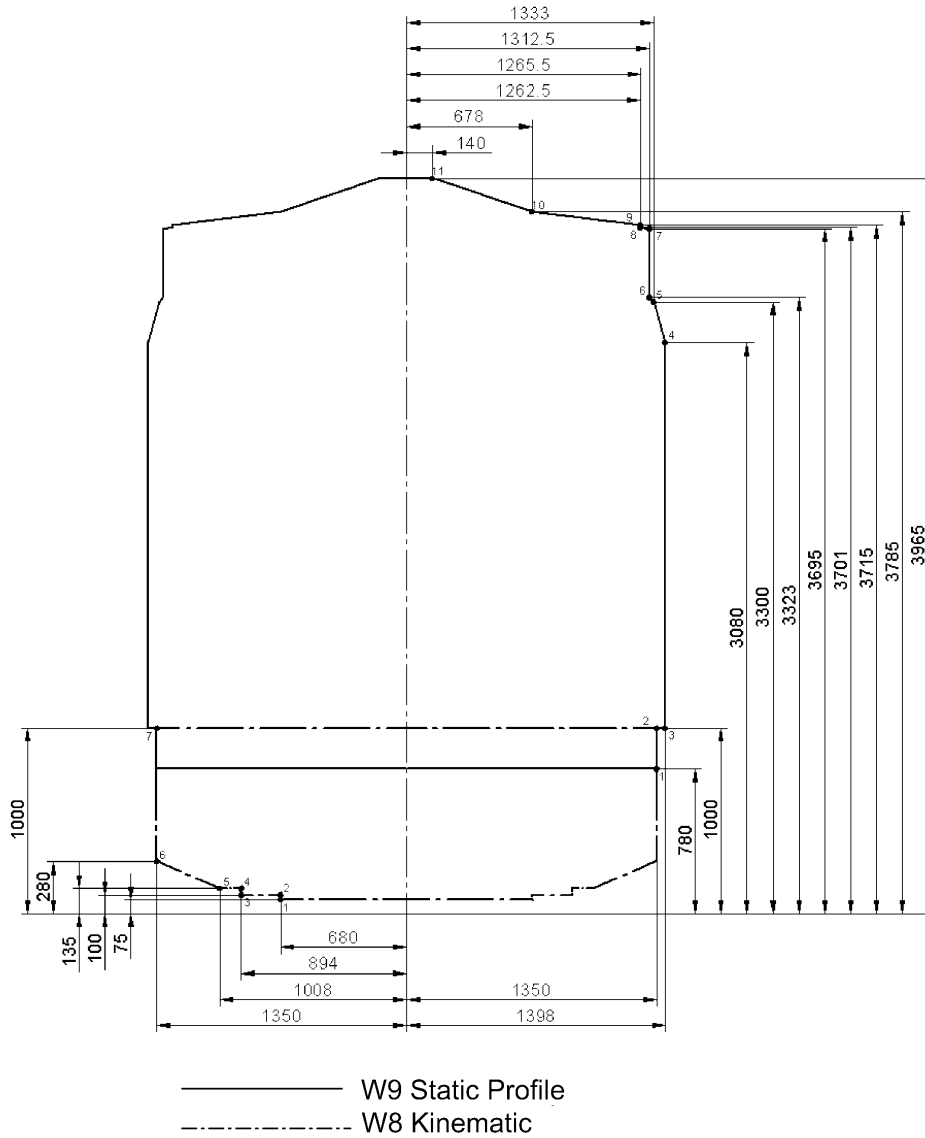

**Co-ordinates for W9 Profile:**

Point:	X	Y
6	1312,5	3323
7	1312,5	3695
8	1262,5	3701
9	1265,5	3715

Container wagons have different positions for different sized Intermodal Units. These intermodal units loaded on container wagons are not fixed in position either laterally or longitudinally. All loading alignments and possible movement during journeys shall be taken into account for both W9 (i) and W9 (o).

- Notes on the reduction formulae and other factors to be considered in the application of Gauge W9

**▼B**

2.1. Gauge W9 (i) is specified for a wagon with a bogie-centre distance of 13,5 m. No increase in the width of the gauge shall be permitted for wagons with a bogie-centre distance of less than 13,5 m but a reduction in the width of the gauge shall be made for wagons with a bogie-centre distance greater than 13,5 m.

2.1.1. Area above 1 000 mm ARL

2.1.1.1. General

2.1.1.2.

This part of gauge W9 (i) shall be considered as static and the gauge width is unaffected by lateral movements of the suspension up to a limiting value of 13 mm (including wear).

The W9 (i) gauge width shall, be reduced in width, either side of the centre line, by an amount corresponding to the lateral movements of the suspension exceeding the limiting value of 13 mm.

The 1 000 mm area above rail level, at a width of 2 796 mm, is an absolute minimum. No part of the load unit shall encroach vertically downwards such that the gauge is infringed under whatever condition of loading or wear. Vertical spring travel shall be determined as the extreme movement to solid, or springstop condition.

**Area comprised between 1 000 mm and 780 mm ARL**

*Fig. T6*

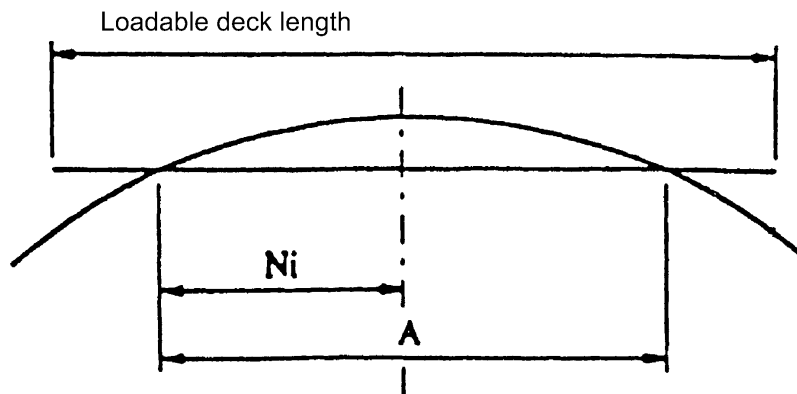

A = bogie-centre distance (in metres)

$N_i$  = distance from section in question to nearest bogie centre (in metres)

R = curve radius

*Note:* Generally the greatest reduction is obtained when  $N_i = A/2$ .

1.1.3. Reduction  $E_i$  (metres) to be made on each side of the gauge at a section between axles/bogies:

$$E_i = \frac{AN_i - N_i^2}{400} - 0,114$$

*Note*

— A negative value calculated from the above Clause 1.1.3 indicates that the reduction to be applied is nil.

— No reduction is necessary at the centre of the vehicle unless the distance between bogie centres exceeds 13,5 m.

**▼B**

The width reduction formula applies equally to all width co-ordinates in the area exceeding 1 000 mm ARL.

### Area between 1 000 mm and 780 mm ARL

#### 2.1. General

2.1.1. This part of the W9 (i) gauge is simplified kinematic

Due account shall be taken of all lateral displacements, however caused:

- a) Full lateral suspension travel,
- b) Full lateral suspension interface wear,
- c) Reduction due to curve throw  $E_i$
- d) Load unit movement described in the introduction to Annex 5 Section D.

The following shall not be included:

- e) Vehicle roll
- f) Axleguard deflection
- g) Wheel flange to rail clearance
- h) Wheel flange and rail wear

#### 2.1.3. Area below 780 mm ARL

##### 2.1.3.1.

No part of the load unit complying with the W9 (i) shall project into this area under any condition of load or wear except where this part of the load unit complies with W6 gauge.

#### 2.1.4. Determination of W9 (i) gauge widths

*Fig. T7*

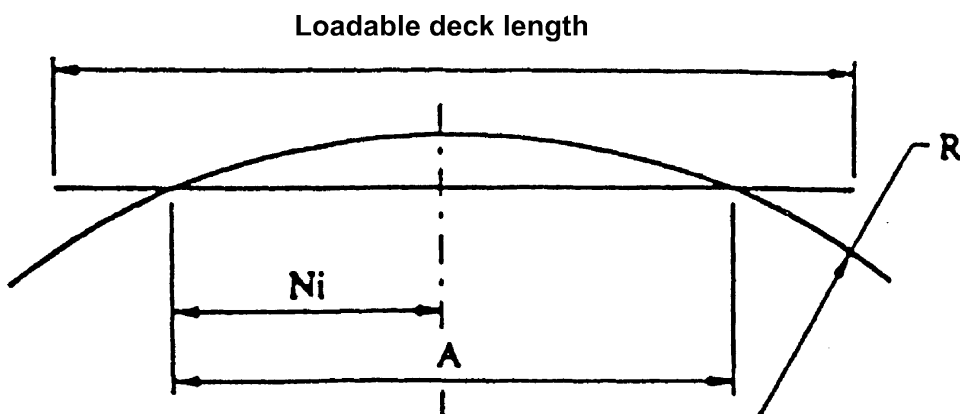

2.1.5. At any point of the vehicle, the combination of its:

- (i) maximum static width, plus
- (ii) the sum of values derived from 2.1.1 a), b), c) and d)

shall not exceed any one of the three values shown below:

Curve radius (R)	maximum width (i) + (ii)
360 m	2 810 mm
200 m	2 912 mm
160 m	2 970 mm



**▼ B**

2.1.5.1. Reduction  $E_i$  (metres) to be made on each side of the gauge at a section between bogies:

$$E_i = \frac{AN_i - N_i^2}{R}$$

2.1.6.2. Note: Any width reduction derived from the above applies equally to all width co-ordinates in the area between 1 000 mm and 780 mm ARL. No increase in width of this gauge is permitted.

3. Sample calculation

3.1. Width reductions calculated in accordance with data relating to W9 (i) gauge.

3.1.1. Bogie wagon, to the following dimensions:

Distance between bogie centres (A)	13,5 m
Length of loadable platform	15,9 m
Full lateral suspension travel, including interface wear	13 mm (i.e. not in excess of the standard value of 13 mm)
Full lateral movement of load unit in relation to securing device	12,5 mm (i.e. 6,5 mm more than the standard value of 6 mm)

3.2. Area above 1 000 mm ARL

3.2.1. At the centre of the wagon

$$E_i = \frac{AN_i - N_i^2}{400} = 0,114$$

$$E_i = \frac{13,5 \times 6,75 - 6,75^2}{400} = 0,114$$

$E_i = -0,00009$ , i.e. no reduction due to curve overthrow.

3.2.2. Overall gauge reduction

=  $E_i$  + excess lateral suspension travel + excess load unit movement

= 0 + 0 + 6,5 mm.

Therefore all horizontal co-ordinates of the W9 (i) gauge, in the area exceeding 1 000 mm ARL, shall be reduced by 6,5 mm on each side of the gauge.

3.3. Area comprised between 1 000 mm and 780 mm ARL

3.3.1.

Total lateral suspension travel = 13 mm.

Excess lateral travel of load unit = 6,5 mm.

3.3.2.

At centre of wagon:

$$E_i = \frac{AN_i - N_i^2}{2R}$$

(i) For  $R = 360$  m  $E_i = 63$  mm

Therefore maximum width at  $R = 360$  m will be:

$$2\,810 - (2 \times 63) - (2 \times 13) - (2 \times 6,5) = 2\,645 \text{ mm}$$

(ii) For  $R = 200$  m  $E_i = 114$  mm

Therefore maximum width at  $R = 200$  m will be:

$$2\,912 - (2 \times 114) - (2 \times 13) - (2 \times 6,5) = 2\,645 \text{ mm}$$

**▼ B**

(iii) For  $R = 160$  m  $E_i$  142 mm

Therefore maximum width at  $R = 160$  m will be:

$$2\,970 - (2 \times 142) - (2 \times 13) - (2 \times 6,5) = 2\,647 \text{ mm}$$

The above cases (i) and (ii) both produce a minimum value and therefore the maximum permissible width of the load unit at the centre of the loadable deck length is thus 2 645 mm.

4. Notes on the reduction formulae and other factors to be considered in the application of Gauge W9 (o)

4.1. Gauge W9 (o) is specified for a wagon with a distance of 13,5 m between bogie centres. No increase in gauge width is permitted for wagons with a distance of less than 13,5 m between bogie centres. However, a gauge reduction shall be applied for wagons with a distance greater than 13,5 m between bogie centres.

4.1.1. Area above 1 000 mm ARL

4.1.1.1. General

This part of gauge W9 (o) is to be considered as static and the gauge width is unaffected by lateral travel of the suspension up to a limiting value of 13 mm.

However the W9 (o) gauge shall be reduced in width, either side of the centre line, by the amount by which the total lateral suspension travels exceeds the standard limiting value of 13 mm.

Any load unit movement allowed by the restraining mechanisms e.g. spigots in excess of 6 mm laterally shall further reduce the width either side of the centreline.

The area 1 000 mm above rail level is an absolute minimum with a width of 2 796 mm. No part of the load unit shall encroach vertically downwards such that the gauge is fouled under any condition of loading or wear. Vertical spring travel shall be determined as the extreme movement to solid, or springstop.

A width of 2 796 mm on straight track (equivalent to 3 024 mm on curves of 200mm radius) shall be allowed without width reduction.

4.1.2.1. Diagram for Width Reduction Formula

*Fig. T7*

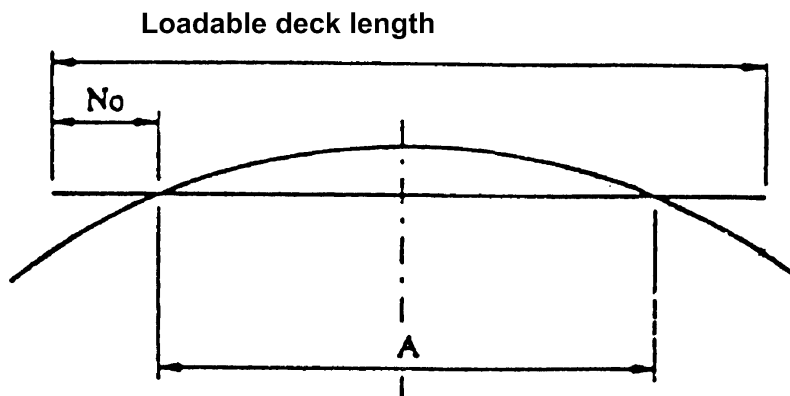

$A$  = distance between bogie centre pins (in metres)

$N_o$  = distance from section in question to the nearest bogie centre pin (in metres)

*Note:* Generally the reduction is greatest when  $N_o$  = maximum.

4.1.3. Formula to be applied for determination of the reduction above 1 000 mm ARL

4.1.3.1.

Reduction  $E_o$  (metres) to be made on each side of the gauge at a section between bogies and the end of the loadable wagon platform.

$$E_o = \frac{AN_o + N_o^2}{400} - 0,114$$

**▼B**

## 4.1.3.2. Note

- A negative value calculated indicates that nil reduction is necessary.
- No reduction is necessary unless the distance to the end of the loadable decks exceeds 2,798 m for a wagon with bogie centres equal to 13,5m.

The width reduction formula applies equally to all width co-ordinates in the area exceeding 1 000 mm above rail ARL.

Area  $\leq$  1 000 mm ARL

## 4.2.2. Area below 1 000 mm ARL

## 4.2.2.1.

**This part of the W9 (o) gauge is kinematic, and the gauge is to be determined precisely in accordance with the reference profile W6, except that the permitted widths must be further reduced dependent upon the load unit securing method.**

The area 1 000 mm above rail level is an absolute minimum with a width of 2 796 mm. No part of the load unit shall encroach vertically downwards such that the gauge is fouled under any condition of loading or wear. Vertical spring travel shall be determined as the extreme movement to solid, or springstop.

## 4.2.2.2. Determination of gauge widths

At any point of the vehicle, the combination of its:

- (i) maximum static width, plus
- (ii) the sum of values derived from 2.1.1 a), b), c) and d)

shall not exceed any one of the three values shown below:

## 4.2.2.3.

Curve radius (R)	maximum width (i) + (ii)
360 m	2 710 mm
200 m	2 820 mm
160 m	2 900 mm

*Fig. T8*

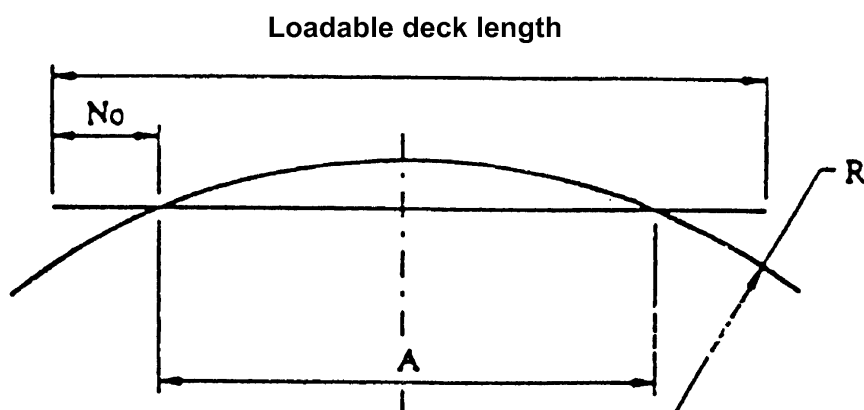

A = distance between bogie centres (in metres)

$N_o$  = distance from section in question to the nearest bogie centre (in metres)

Note: the reduction is at its greatest when  $N_o = A/2$

R = curve radius (in metres)

Formula to be applied for the determination of reductions below 1 000 mm ARL

**▼B**

Reduction  $E_o$  (in metres) to be made on each side of the gauge at a section between bogie and the end of the loadable wagon platform:

$$E_i = \frac{AN_o + N_o^2}{R}$$

Note

— Any width reduction derived from the above applies equally to all width co-ordinates, within the area of less than 1 000 mm ARL.

— No increase in the width of this gauge is permitted.

Width reductions calculated in accordance with data relating to W9 (o) gauge.

Sample calculation

Width reductions calculated in accordance with data relating to the W9 (o) gauge

Bogie wagon, to the following dimensions:

Distance between bogie centre pins (A)	13,5 m
Length of loadable platform	15,9 m
Full lateral suspension travel, including interface wear	13 mm (i.e. not in excess of the standard value of 13 mm)
Full lateral movement of load unit by reference to securing device	12,5 mm (i.e. 6,5 mm more than the standard value of 6 mm)

Area above 1 000 mm ARL

At the end of the load unit

$$E_o = \frac{AN_o + N_o^2}{400} - 0,114 \text{ where } N_o = \frac{15,9 - 13,5}{2} = 1,2$$

$$E_o = - 0,070 \text{ m}$$

Total gauge reduction

$$= E_o + \text{excess lateral suspension travel} + \text{excess load unit movement}$$

$$= - 70 + 0 + 6,5 = - 63,5 \text{ mm, i.e. negative therefore no reduction needed.}$$

Area below 1 000 mm ARL

Total Lateral Suspension Travel = 13mm

Excess Lateral Travel of Load Unit = 6,5 mm

At the end of the load unit:

$$E_o = \frac{AN_o + N_o^2}{2R}$$

$$(i) \text{ For } R = 360 \text{ m} \quad E_o = 24,5 \text{ mm}$$

Therefore maximum width at  $R = 360 \text{ m}$ :

$$2\,700 - (2 \times 24,5) - (2 \times 13) - (2 \times 6,5) = 2\,612 \text{ mm}$$

$$(ii) \text{ For } R = 200 \text{ m} \quad E_o = 44 \text{ mm}$$

Therefore maximum width at  $R = 200 \text{ m}$ :

$$2\,820 - (2 \times 44) - (2 \times 13) - (2 \times 6,5) = 2\,693 \text{ mm}$$

$$(iii) \text{ For } R = 160 \text{ m} \quad E_o = 55 \text{ mm}$$

Therefore maximum width at  $R = 160 \text{ m}$ :

$$2\,900 - (2 \times 55) - (2 \times 13) - (2 \times 6,5) = 2\,751 \text{ mm}$$

Case (i) produces a minimum value, and therefore the maximum permissible width of the load unit at the end of the loadable deck length is thus 2 612 mm.



## ANNEX U

## SPECIFIC CASES

## Kinematic gauge

## 1 520 mm track gauge

- U.1 WAGONS FOR BOTH 1520 MM AND 1435 MM TRACKS
- U.2 WAGONS FOR ONLY 1520 MM TRACKS
- U.3 PASSING OVER TRANSITION CURVES
- U.4 PASSING OVER VERTICAL TRANSITION CURVES (INCLUDING MARSHALLING YARD HUMPS) AND OVER BRAKING, SHUNTING OR STOPPING DEVICES.
- U.5 ABILITY TO COUPLE

This specific case applies to selected lines in Poland and Slovakia whose gauge is 1 520 mm, which links to lines in Lithuania, Latvia and Estonia.

## U.1. WAGONS FOR BOTH 1 520 MM AND 1 435 MM TRACKS

Interoperability wagons for 1 520 mm and 1 435 mm network to operate without any limitation on both networks should comply with the kinematic gauge shown in fig. U1.

Fig. U1

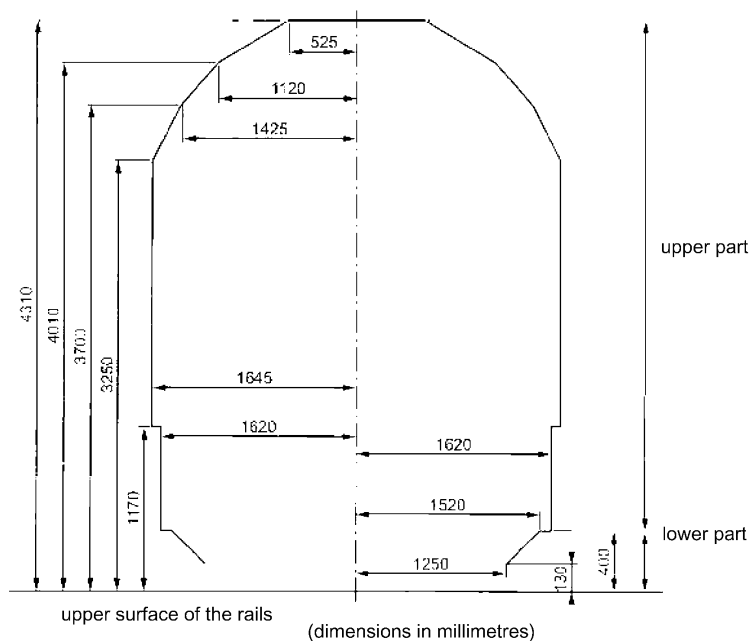

▼ B

The upper parts of certain wagons used in bilateral and multilateral agreements may conform to the gauge in fig. U2.

Fig.U2

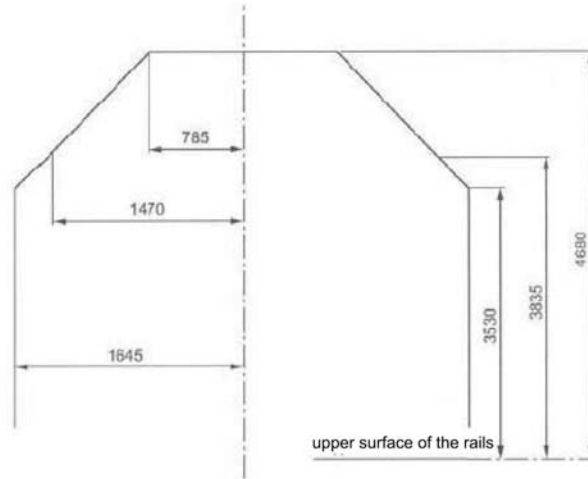

For the lower parts of these wagons the kinematic gauge should comply with fig.U3.

Fig.U3

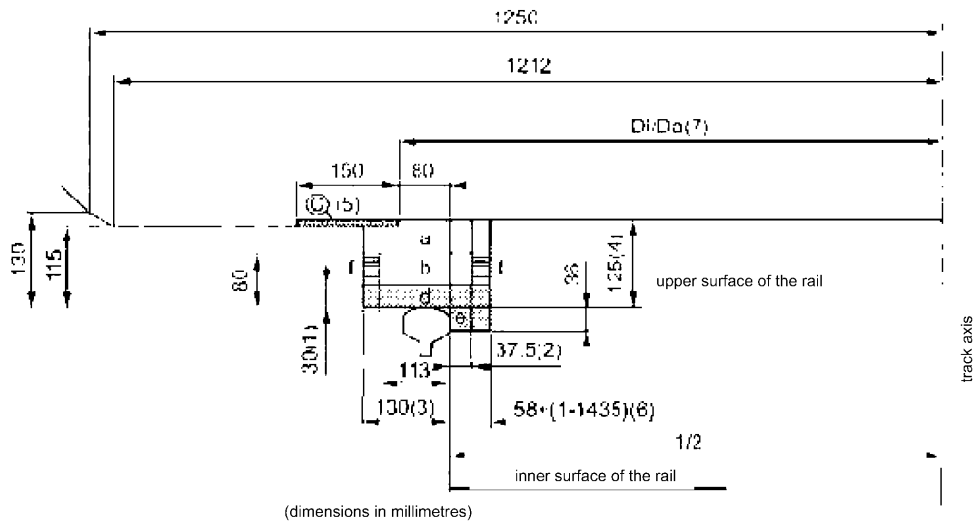

**▼B**

U.2. WAGONS FOR ONLY 1 520 MM TRACKS

These freight wagons may comply with kinematic gauges WM-02, WM-1 and WM-0.

*Fig. U4*

**Kinematic gauge WM-2**

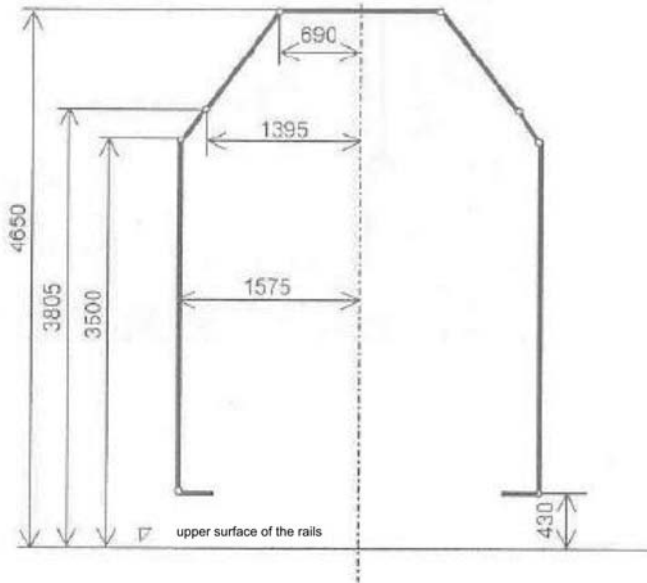

*Fig.U5*

**Kinematic gauge WM-1**

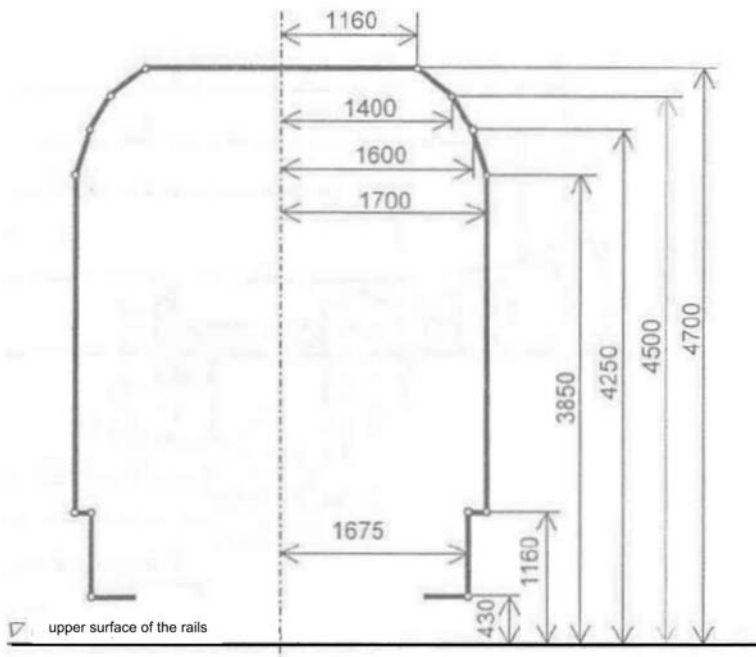

▼B

Fig. U6

## Lower parts for kinematic gauge WM-02, 1, 0

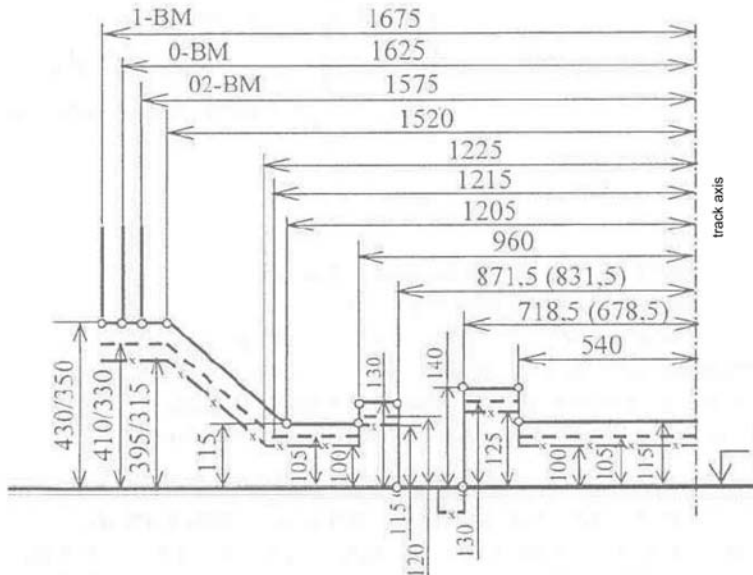

## U.3. PASSING OVER TRANSITION CURVES

Individual wagons, both loaded and unloaded should negotiate curves with a radius of 80 m.

On 1 520 mm tracks wagons both loaded and unloaded, coupled to form a train shall negotiate;

- the transition between straight track and 80 m radius curve without transitory curves.
- ‘S’ curves of 120 m radius without transitory straight tracks

On 1 520 mm tracks long wagons (spacing of king-pins > 16 m and length with couplers > 21 m) both loaded and unloaded, coupled to form a train should negotiate;

- the transition between straight track and 110 m radius curve without transitory curves.
- ‘S’ curves with a radius of 160 m without transitory straight tracks

On 1 435 mm tracks wagons both loaded and unloaded, coupled to form a train should negotiate;

- ‘S’ curves with a radius of 190 m without transitory straight tracks
- ‘S’ curves with a radius of 150 m with a transitory straight track 6 m in length
- ‘S’ curves with a radius of 120 m with a transitory straight track 20 m in length



▼ B

## U.4. PASSING OVER VERTICAL TRANSITION CURVES (INCLUDING MARSHALLING YARD HUMPS) AND OVER BRAKING, SHUNTING OR STOPPING DEVICES.

Passing over vertical profiles as shown in figs. U7 and U8 shall be possible without disconnection of the automatic couplers.

Fig. U7

## First track retarder before first turnout

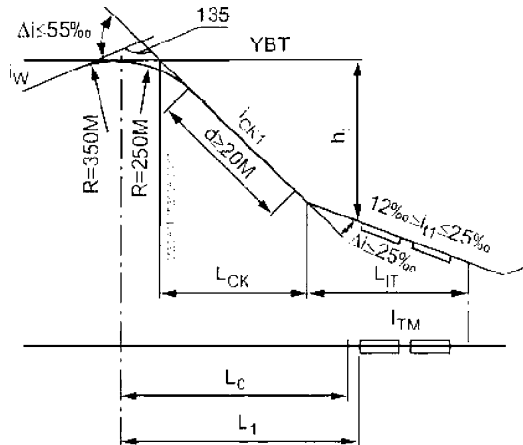
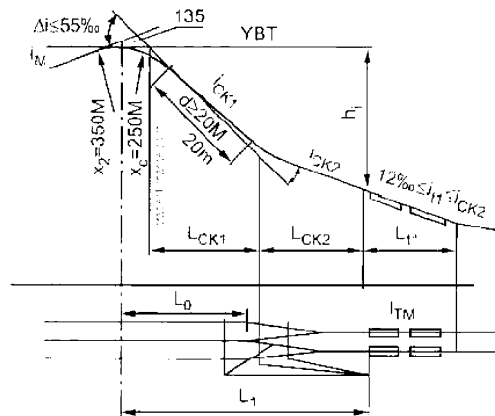

Fig. U8

## First track retarder after first turnout



## U.5. ABILITY TO COUPLE

Wagons with automatic couplers both loaded and unloaded shall allow coupling in the following conditions;

- without manual (hand) support
  - on straight tracks
  - on transition from straight track into a curve with a radius of 135 m without transitory straight track
  - on curves with a radius of 150 m
- manually (with hand support)
  - on 'S' curves with a radius of 190 m without transitory straight track
  - on 'S' curves with a radius of 150 m with a transitory straight track 6 m in length

**▼B**

Long wagons (spacing of king-pins > 16 m and length with couplers > 21 m) both loaded and unloaded with automatic couplers shall allow coupling in the following conditions:

- without manual (hand) support
  - on straight tracks
  - on transition from straight track into a curve with a radius of 150 m without transitory straight track
  - on curves with a radius of 150 m
- manually (with hand support)
  - on 'S' curves with a radius of 190 m without transitory straight track
  - on 'S' curves with a radius of 150 m with a transitory straight track 6 m in length



## ANNEX V

### SPECIFIC CASE

#### Braking performance

##### Great Britain

#### V.1. PARKING BRAKE FOR FREIGHT WAGONS INTENDED FOR USE ON THE GREAT BRITAIN NETWORK

Specification for parking brake: For new wagons used in the UK: every wagon has to be equipped. For wagons to be used solely in the UK, a parking brake shall be designed such that fully loaded wagons shall be held on a gradient of 2,5 % with a maximum of 10 % adhesion with no wind.

#### V.2. EQUIVALENT BRAKE FORCE & BRAKE FORCE FACTORS FOR FREIGHT WAGONS INTENDED FOR USE ON THE GREAT BRITAIN NETWORK

Freight wagons operating in the UK shall have the equivalent brake force and, if applicable, any brake force factors calculated. Freight wagons operating in member states other than the UK shall have the brake weight/braked weight percentage calculated. Freight wagons required to operate in the UK and other member states shall have both equivalent brake force/brake force factors and brake weight/braked weight percentage calculated. The keeper shall be required to obtain this information and enter it into the Rolling Stock Register.

##### **Brake Force**

The force applied to the brake block/pad/braking surface interface.

##### **Equivalent Brake Force**

Is the value of brake force that needs to be exerted on an equivalent tread brake arrangement with a standard coefficient of friction, to produce the same value of brake retarding force as that given by the actual combination of brake force and coefficient of friction on the vehicle.

##### **Brake Force Factors**

These are factors that enable the UK TOPS computer system to calculate the brake force on a rail vehicle fitted with a device that varies the brake force in proportion to the vehicle mass.

##### **Calculation of Brake Force Data**

- i) *Vehicles with either a single value of brake force, or values fixed for the tare and laden conditions.*

The approach defined in this section shall also be used for coaching stock, even though they may have a brake force that varies with the vehicle load. The value of equivalent brake force calculated shall be that for the tare condition of the vehicle.

The equivalent brake force is the total for the vehicle and is directly related to the vehicle brake retarding force acting at the rail.

The declared value of brake force is used directly as an index of the braking ability of the vehicle and to be consistent with existing values, is the force that needs to be exerted on an equivalent tread brake arrangement to give the same brake retarding force at the rail, using a standard mean coefficient of friction at the friction braking interface. The standard mean coefficient of friction historically used, as the basis for the calculations, is 0,13.

The equivalent brake forces as required above, must be calculated from the brake retarding force as follows:

$$B_T = \frac{F_T}{0,13 \times 9,81} \quad \text{and} \quad B_L = \frac{F_L}{0,13 \times 9,81}$$

**▼ B**

Where:

$B_T$  = the equivalent brake force to be for the rail vehicle in tare condition (tonnes).

$B_L$  = the equivalent brake force to be declared for the rail vehicle in laden condition (tonnes).

$F_T$  &  $F_L$  = the vehicle brake retarding force, appropriate for the tare or laden condition respectively, that acts at the rail and over the period during which the brake cylinder pressure has reached at least 95 % of its maximum value (kN).

0,13 = the standard mean coefficient of friction (-).

9,81 = acceleration due to gravity (m/s<sup>2</sup>).

ii) *Vehicles with a value of brake force that varies in proportion to the load*

For those vehicles for which it is necessary to calculate brake force factors, that are in the form of a constant and a variable component, these shall be calculated as follows:

(a) Brake force factor **1** =  $C_L$  or  $C_T$  (tonnes)

where  $C_L = B_L - (m \times W_L)$

and  $C_T = B_T - (m \times W_T)$

See below for the derivation of **m**

(b) Brake force factor **2** =  $\frac{(B_L - B_T)}{(W_L - W_T)} = m$  (tonnes/tonne)

Where

$B_L$  = Equivalent brake force in max laden condition (tonnes).

$B_T$  = Equivalent brake force in tare condition (tonnes)

$W_L$  = Max laden mass (tonnes)

$W_T$  = Tare mass (tonnes)

The values of brake force factor calculated at **(a)** & **(b)** above are to be recorded in the Rolling Stock Register.

iii) *Factors to be considered in the derivation of brake force*

The brake retarding force for a vehicle can be calculated from design data or derived from the results of braking distance tests, in either case this must be from the rail vehicle maximum speed. Where actual tests are undertaken, the value of equivalent brake force calculated must be validated.

For tread braked vehicles, the brake retarding force is calculated from the product of the total value of the brake force and the coefficient of friction between the brake blocks and wheel tread. In the case of a disc brake, it is the product of the brake force, coefficient of friction and the ratio of effective radius at which the disc pad acts and the new wheel radius of the vehicle.

When calculating brake retarding force, account must taken of any losses due to rigging efficiency, or slack adjusters within the brake force application system, between the brake cylinder and brake blocks or pads. If a reliable value for brake force cannot be derived, it should be measured directly at the block or pad. In this case account must be taken of the effects of vibration on the value of static friction in the rigging.

The coefficient of friction used must take account of all influencing aspects, such as the brake force, the area of the friction material and vehicle speed, as all these factors affect the value of the coefficient of friction. For example, for a given brake block area, increasing block loads and speeds will reduce the effective value of the coefficient of friction for cast iron brake blocks.

If there is no data available giving the coefficient of friction for particular combinations of load, speed and area of the friction interface, tests must be undertaken to establish a value, if it is used to calculate brake retarding force.

**▼B**

Where there is one vehicle number to cover vehicles that are semi-permanently coupled by bar type couplers or are articulated, the correct brake retarding force must be calculated for each distributor by using the vehicle weight controlled by each distributor.



*ANNEX W*

**SPECIFIC CASES**

**Kinematic gauge**

**FINLAND, STATIC GAUGE FIN1**

- W.1. General rules
- W.2. Lower part of the vehicle
- W.3. Vehicle parts in proximity of the wheel flanges
- W.4. Vehicle width
- W.5. Lower step and access doors opening outwards for coaches and multiple units
- W.6. Pantographs and non-insulated live parts on the roof
- W.7. Rules and later instructions

**VEHICLE GAUGES**

FIN1/Appendix A

FIN1/Appendix B1

**INCREASE OF THE MINIMUM HEIGHT OF THE LOWER PART OF THE VEHICLE ABLE TO PASS OVER MARSHALLING HUMPS AND RAIL BRAKES 5**

FIN1/Appendix B2

**INCREASE OF THE MINIMUM HEIGHT OF THE LOWER PART OF THE VEHICLE UNABLE TO PASS OVER MARSHALLING HUMPS AND RAIL BRAKES**

FIN1/Appendix B3

**LOCATION OF THE RAIL BRAKES AND OTHER SHUNTING DEVICES OF MARSHALLING HUMPS**

FIN1/Appendix C

**REDUCTION OF THE HALF-WIDTH ACCORDING TO THE VEHICLE GAUGE FIN1, (REDUCTION FORMULAE)**

FIN1/Appendix D1

**GAUGE OF THE VEHICLE LOWER STEP**

FIN1/Appendix D2

**GAUGE OF OUTWARDS OPENING DOORS AND OF OPENED STEPS FOR COACHES AND MULTIPLE UNITS**

FIN1/Appendix E

**PANTOGRAPH AND NON-INSULATED LIVE PARTS**

**▼B****W.1. GENERAL RULES**

- 1.1. The vehicle gauge determines the space where the vehicle should be inside when it is in middle position on a straight track. The reference contour (FIN1) is given in Appendix A.
- 1.2. To define the lowest position of the various parts of the vehicle (lower part, parts in the proximity of the flanges) in relation to the track, the displacements hereafter should be considered:
  - Maximum wears
  - Flexibility of suspensions up to the buffers. For grounds which will be made clear, the flexibility of springs has to be taken into account according to the ranking of the UIC Leaflet 505-1.
  - Static deflection of the frame
  - Mounting and construction tolerances
- 1.3. For the definition of the highest location of the various parts of the vehicle, the vehicle is supposed empty, not worn and with mounting and construction tolerances.

**W.2. LOWER PART OF THE VEHICLE**

The minimum height allowed for the lower parts should be increased according to Appendix B1 for vehicles able to pass over marshalling yard humps and rail brakes.

The vehicles not allowed passing over marshalling yard humps and rail brakes can have a minimum height increased according to Appendix B2.

**W.3. VEHICLE PARTS IN PROXIMITY OF THE WHEEL FLANGES**

- 3.1. The minimum vertical distance allowed for vehicle parts located in the vicinity of the wheel flanges, except the wheel themselves, is 55 mm from the running surface. In curves those parts should remain inside the zone occupied by the wheels.
 

This distance of 55 mm does not apply to the flexible parts of the sanding system or to the flexible brushes.
- 3.2. In exception for the point 3.1, the minimum vertical distance allowed for parts beyond end axles is 125 mm, for vehicles which are retarded by a movable, manually on the rail placed drag shoe.
- 3.3. The minimum distance of brake components which should come in contact with the rail can be smaller than 55 mm from the rail when the components are stationary. They should be located inside the zone between axles and even in curves remain inside the zone occupied by the wheels. The components should not affect operation on shunting devices.

**W.4. VEHICLE WIDTH**

- 4.1 Transverse half-width dimensions allowed on straight track and in curve should be reduced according to Appendix C.

**W.5. LOWER STEP AND ACCESS DOORS OPENING OUTWARDS FOR COACHES AND MULTIPLE UNITS**

- 5.1 The gauge of the lower step of coaches and multiple units is given in Appendix D1.
- 5.2. The gauge in open position of access doors opening outwards on coaches and multiple units is given in Appendix D2.

**W.6. PANTOGRAPHS AND NON-INSULATED LIVE PARTS ON THE ROOF**

- 6.1. The lowered pantograph in middle position on a straight track should not protrude out the vehicle gauge.
- 6.2. The raised pantograph in middle position on a straight track should not protrude out the vehicle gauge given in Appendix E.
 

The transverse displacements of a pantograph due to oscillations and track inclination and tolerances should be separately taken into account at the time of the installation of the electric line.
- 6.3. If the pantograph is not above the centre of the bogie, the lateral displacement due to the curves should also be taken into account.

**▼B**

- 6.4. Non-insulated parts (25 kV) on the roof should not penetrate the zone indicated in Appendix E.

**W.7. RULES AND LATER INSTRUCTIONS**

- 7.1. Besides items W.1-W.6, the vehicles designed for the western traffic also comply with prescriptions of UIC Leaflets 505-1 or 506.

The lower part of the vehicles able to board ferries should later comply with UIC Leaflet 507 (wagons) or 569 (coaches and vans).

- 7.2. Besides items W.1-W.6, the vehicles designed for the traffic with Russia also comply with prescriptions of norm GOST 9238-83. In any case, the usual gauge should be complied with.
- 7.3. A separate regulation is used for gauging trainsets made up of vehicle with tilting body systems.
- 7.4. Loading gauges are dealt with by a separate regulation.



▼ B

## VEHICLE GAUGES

FIN1/Appendix A

Figure W.1

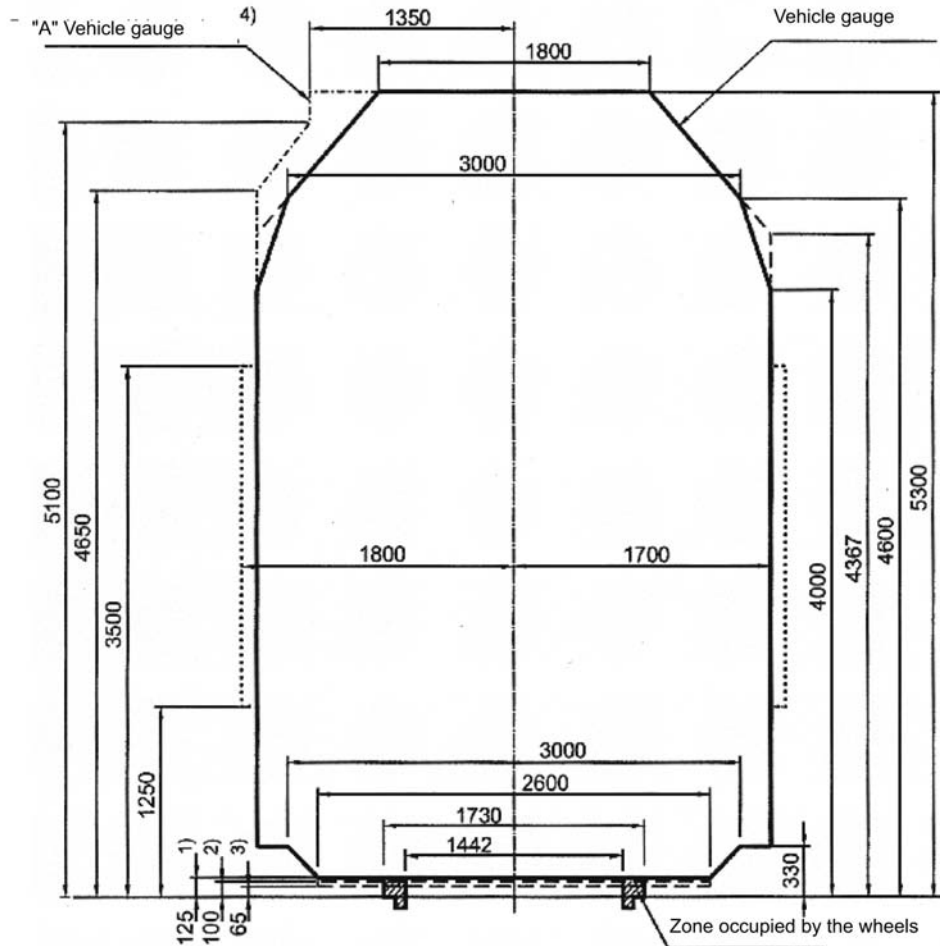

..... Lights and rear-view mirrors. For rear-view mirrors, see Appendix D2, item 1, note.

--- Vehicle gauge widening (FIN1); a separate regulation is to be applied for the adoption.

- 1) Lower part of the vehicles able to pass over marshalling humps and rail brakes.
- 2) Lower part of the vehicles unable to pass over marshalling humps and rail brakes except for bogies of powered units, see note 3).
- 3) Lower part of the bogies of powered units unable to pass over marshalling humps and rail brakes.
- 4) Gauge of the vehicles able to run on lines individuated in Jtt (technical specifications related to Finnish Railway's safety standards), where the obstacle gauge has been accordingly widened.

**▼ B***FIN1/Appendix B1***Increase of the minimum height of the lower part of the vehicle able to pass over marshalling humps and rail brakes**

The height of the lower part of vehicles should be increased by  $E_{as}$  and  $E_{au}$  so that:

- if the vehicle runs on the top of a hump, no part between bogie pivots or between end axles could penetrate the running surface of a hump the vertical curvature radius of which is 250 m;
- if the vehicle runs in the concavity of the hump, no part beyond bogie pivots or beyond end axles could penetrate the gauge of rail brakes of a concavity the vertical curvature radius of which is 300 m.

The formulae to <sup>(1)</sup> to calculate the height increase, are (values in metres):

$$E_{as} = \frac{an - n^2}{500} - h$$

$$E_{au} = \frac{an + n^2}{600}$$

at a distance up to 1,445 m from the centreline of the track

$$E_{au} = \frac{an + n^2}{600} - (h - 0,275)$$

at a distance greater than 1,445 m from the centreline of the track

Notations:

$E_{as}$  = height increase of the lower part of the vehicle in cross sections between bogie pivots or between end axles.  $E_{as}$  should not be taken into account unless its value is positive;

$E_{au}$  = height increase of the lower part of the vehicle in cross sections beyond bogie pivots or beyond end axles.  $E_{au}$  should not be taken into account unless its value is positive;

$a$  = distance between bogie pivots or between end axles;

$n$  = distance from the cross section considered to the nearest bogie pivot (or the nearest end axle);

$h$  = height of the lower part of the vehicles above the running surface (see Appendix A).

<sup>(1)</sup> Formulae are based on the position of a rail brake and other shunting devices of marshalling humps shown in Appendix B3.

**▼ B***FIN1/Appendix B2***Increase of the minimum height of the lower part of the vehicle unable to pass over marshalling humps and rail brakes**

The height of the lower part of vehicles should be increased by  $E'_{as}$  and  $E'_{au}$  so that:

- if the vehicle runs over a concave track transition, no part between bogie pivots or between end axles could penetrate the running surface of the track transition the vertical curvature radius of which is 500 m;
- if the vehicle runs over a concave track transition, no part beyond bogie pivots or beyond end axles could penetrate the running surface of the track transition the vertical curvature radius of which is 500 m.

The formulae <sup>(1)</sup> to calculate the height increase are (values in metres)

$$E'_{as} = \frac{an - n^2}{1000} - h$$

$$E'_{au} = \frac{an + n^2}{1000} - h$$

Notations:

$E'_{as}$  = Height increase of the lower part of the vehicle in cross sections between bogie pivots or between end axles.  $E'_{as}$  should not be taken into account unless its value is positive.

$E'_{au}$  = Height increase of the lower part of the vehicle in cross sections between bogie pivots or between end axles.  $E'_{au}$  should not be taken into account unless its value is positive.

$a$  = distance between bogie pivots or between end axles;

$n$  = distance from the cross section considered to the nearest bogie pivot (or the nearest end axle)

$h$  = height of the lower part of the vehicles above the running surface (see Appendix A).

<sup>(1)</sup> Formulae are based on the vehicle gauge for tracks on marshalling humps as shown in Appendix B3

▼B

FIN1/Appendix B3

LOCATION OF THE RAIL BRAKES AND OTHER SHUNTING  
DEVICES OF MARSHALLING HUMPS

Figure W.2

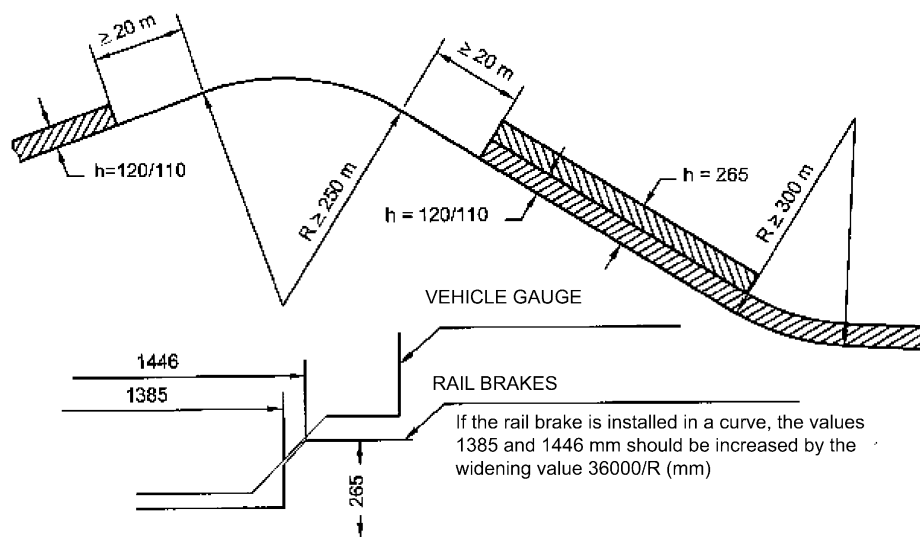

PASSING TRACKS:

On the passing tracks of marshalling humps  $R_{\min} = 500$  m, and the height of obstacle gauge above the running surface is  $h = 0$  mm across the whole vehicle gauge width (= 1700 mm from track centreline). The longitudinal area where  $h = 0$  spreads from the point of 20 m before the convex area on the top of the hump to the point of 20 m after the concave area at the valley of the hump. The obstacle gauge for the marshalling yard is valid outside this area (RAMO item 2.9 and RAMO 2 Annex 2, related to the gauge of marshalling yards, and also RAMO 2 Annex 5 related to the points of crossings).

▼ **B**

## FIN1/Appendix C

**Reduction of the half-width according to the vehicle gauge FIN1, (reduction formulae)****1. General rules**

The cross dimensions of the vehicles computed according to the vehicle gauge (Appendix A) should be decreased by the quantities  $E_s$  or  $E_u$ , so that, when the vehicle is in its least favourable position (without inclination on its suspension) and on a track of radius  $R = 150$  m, with a track gauge of 1,544 m, no part of the vehicle protrude the half-width of the vehicle gauge FIN1 by more than  $(36/R + k)$  from the track centreline.

The centreline of the vehicle gauge coincides with the track centreline, this one being inclined if the track is canted.

Reductions are calculated according to formulae given in chapter 2.

**2. Reduction formulae (in metres)****2.1 Sections between bogie pivots or between end axles**

$$E_s = \frac{an - n^2}{2R} + \frac{p^2}{8R} + \frac{1-d}{2} + q + w_{iR} - \left( \frac{36}{R} + k \right)$$

$$E_{s\infty} = \frac{1-d}{2} + q + w_{\infty} - k$$

**2.2 Sections beyond bogie pivots or beyond end axles (vehicles with a overhang)**

$$E_u = \frac{an + n^2}{2R} - \frac{p^2}{8R} + \left( \frac{1-d}{2} + q \right) \frac{2n + a}{a} + w_{iR} \frac{n}{a} + w_{aR} \frac{n + a}{a} - \left( \frac{36}{R} + k \right)$$

$$E_{u\infty} = \left( \frac{1-d}{2} + q + w_{\infty} \right) \frac{2n + a}{a} - k$$

Notations:

$E_s, E_{s\infty}$  = reduction of the gauge half-width for cross sections between bogie pivots or between end axles.  $E_s$  and  $E_{s\infty}$  should not be taken into account unless their values are positive;

$E_u, E_{u\infty}$  = reduction of the gauge half-width for cross sections beyond bogie pivots or beyond end axles.  $E_u$  and  $E_{u\infty}$  should not be taken into account unless their values are positive;

$a$  = distance between bogie pivots or between end axles <sup>(1)</sup>;

$n$  = distance between the cross section considered and the nearest bogie pivot, or the nearest end axle or the fictional pivot if the vehicle has no fixed pivot;

$p$  = bogie wheelbase;

$q$  = is the sum of the play between the axle box and the axle itself and of the possible play between the axle box and the bogie frame measured from the middle position with ultimately worn components;

$w_{iR}$  = possible transverse displacement of the bogie pivot, and the cradle in relation to the bogie frame or, for vehicles without bogie pivot, possible displacement of the bogie frame in relation to the vehicle frame measured from the middle position towards the internal side of the curve (varies according to the curve radius);

<sup>(1)</sup> If the vehicle has no actual bogie pivot,  $a$  and  $n$  should be determined on the base of a fictional pivot located at the intersection of the longitudinal centrelines of the bogie and of the frame, the vehicle being in middle position ( $0,026 + q + w = 0$ ) on a curved track of radius 150 m. If the distance between the pivot calculated by this manner and the bogie centre point is denoted  $y$ , the term  $p^2$  should be replaced by  $p^2 - y^2$  in reduction formulae.

**▼ B**

- $w_{aR}$  = comme  $w_{iR}$ , but towards the outside of the curve;
- $w_{\infty}$  = as  $w_{iR}$ , but on a straight track, from the middle position and towards both side;
- $l$  = maximum track gauge in straight and in considered curved track = 1,544 m;
- $d$  = distance between ultimately worn wheel flanges, measured 10 mm outwards the running circle = 1,492 m;
- $R$  = curve radius;

If  $w$  is constant or varies linearly according to  $1/R$ , the radius to be considered is 150 m.

In exceptional cases, the actual value of  $R \geq 150$  m should be used.

$k$  = allowable gauge protrusion (to be increased by the  $36/R$  widening of obstacle gauge) without the inclination due to the suspension flexibility;

= 0 for  $h < 330$  mm for vehicles able to run over rail brakes (see Appendix B1),

= 0,060 m for  $h < 600$  mm,

= 0,075 m for  $h \geq 600$  mm.

$h$  = height above the running surface at the considered location, the vehicle being in its lowest position.

### 3. Reduction values

The half-width of vehicle cross-sections should be decreased:

3.1 For sections between bogie pivots;

By the greater of values  $E_s$  and  $E_{s\infty}$ .

3.2 For sections beyond bogie pivots;

By the greater of values  $E_u$  and  $E_{u\infty}$ .



*FIN1/Appendix D1*

**GAUGE OF THE VEHICLE LOWER STEP**

1. This norm concerns the step used either for high (550/1 800) or for low platforms (265/1 600).

To avoid a uselessly wide gap between the step and the platform edge and taking account of the lower vehicle step and of high platforms (550/1 800 mm), the value 1,700 - E can be exceeded in compliance with Appendix C, if a fixed step is concerned. In such a case, the calculations hereafter should be applied which allow checking that, in spite of the protrusion, the step will not reach the platform. The coach should be examined in its lowest position in relation to the running surface.

2. Distance between the track centreline and the platform:

3. Room required for the step:  $L = 1,800 + \frac{36}{R} - t$

- 3.1 Step located between bogie pivots:  $A_s = B + \frac{an - n^2}{2R} + \frac{p^2}{8R} + \frac{1-d}{2} + q + w_{iR}$

- 3.2 Step located beyond bogie pivots:

$$A_u - B + \frac{an + n^2}{2R} - \frac{p^2}{8R} + \left( \frac{1-d}{2} + q \right) \frac{2n + a}{a} + w_{iR} \frac{n}{a} + w_{aR} \frac{n + a}{a}$$

4. Notations (values in metres):

$A_s, A_u$  = distance between the track centreline and the outer edge of a step;

$B$  = distance between the vehicle centreline and the outer edge of the step;

$a$  = distance between bogie pivots or between end axles;

$n$  = distance of the step cross section most remote from the bogie pivot;

$p$  = bogie wheel base;

$q$  = possible transverse displacement due to the play between the axle and the axle box added with the play between the axle box and the bogie frame measured from the middle position with ultimately worn components;

$w_{iR}$  = possible transverse displacement of the bogie pivot and the cradle, measured from the middle position towards the internal side of the curve;

$w_{aR}$  = comme  $w_{iR}$ , but towards the outside of the curve;

$w_{iR/aR}$  = maximum value in considered curved track (for fixed steps);  
= 0,005 m (for controlled steps which for  $v \leq 5$  km/h unfurl automatically);

$l$  = maximum track gauge in straight and in considered curved track = 1,544 m;

$d$  = distance between ultimately worn wheel flanges, measured 10 mm outwards the running circle = 1,492 m;

$R$  = Curve radius = 500 m ....  $\infty$ ;

$t$  = allowed tolerance (0,020 m) for the displacement of the rail towards the platform between two maintenance actions.

5. Rules related to the transverse distance between the step and the platform:

- 5.1 Distance  $AV = L - A_{s/u}$  should be at least 0,020 m.

- 5.2 On a straight track, with a coach in its middle position and a platform in its nominal location, a 150 mm distance between vehicle and platform is considered as sufficiently small. Anyway the smallest value should be sought for this distance. In the opposite case, the check is made on a straight and on a curved track where  $A_{s/u}$  is maximum.

**▼B**

## 6. Gauge check

Gauge check for the lower steps should be carried out on a straight track and on a 500 m curve, if value  $w$  is constant or varies linearly according to  $1/R$ . Otherwise, the check should be carried out on a straight track and on curve where  $A_{s/u}$  is maximum.

## 7. Display of the outputs

Formulae used, inserted and resulting values should be displayed in an easily understood manner.



**▼B***FIN1/Appendix D2***Gauge of outwards opening doors and of opened steps for coaches and multiple units**

1. To avoid a uselessly wide gap between the step and the platform edge, the value 1,700 — E (see UIC Leaflet 560 § 1.1.4.2) can be exceeded in compliance with Appendix C, in the design of an outwards opening door with a step in open or closed position, or when the door and the step are moving between open and closed positions. In this case the checks hereafter should be carried out, among others to evidence that, in spite of the additional displacement, neither the door nor the step interfere with the fixed equipment (RAMO item 2.9 Annex 2). In the calculations the coach should be examined in its lowest position in relation to the running surface.

Hereafter, the word door includes the step as well.

NOTE: Appendix D2 may also be used to check the outer rear-view mirror of a loco and motor car the mirror being in open position. During normal line traffic the mirror is closed in a position recessed inside the body gauge.

2. The distance between the track centreline and the fixed equipment is:

$$L = AT + \frac{36}{R} - t;$$

$$AT = 1,800 \text{ m when } h < 600 \text{ mm,}$$

$$AT = 1,920 \text{ m when } 600 < h \leq 1\,300 \text{ mm,}$$

$$AT = 2,000 \text{ m when } h > 1\,300 \text{ mm.}$$

3. Room required for to the door:

3.1. Door located between bogie pivots:  $O_s = B + \frac{an - n^2}{2R} + \frac{p^2}{8R} + \frac{1-d}{2} + q + w_{iR}$

3.2. Door located beyond bogie pivots:  $O_u = B + \frac{an + n^2}{2R} - \frac{p^2}{8R} + \left(\frac{1-d}{2} + q\right) \frac{2n+a}{a} + w_{iR} \frac{n}{a} + w_{aR} \frac{n+a}{a}$

4. Notations (values in metres):

AT = nominal distance between the track centreline and the fixed equipment (on a straight track);

h = height above the running surface at the considered location, the vehicle being in its lowest position;

$O_s, O_u$  = distance allowed between the track centreline and the door edge, when the door is in its most protruding position;

B = distance between the vehicle centreline and the door edge, when the door is in its most protruding position;

a = distance between bogie pivots or between end axles;

n = distance of the door cross section most remote from the bogie pivot;

p = bogie wheel base;

q = possible transverse displacement due to the play between the axle and the axle box added with the play between the axle box and the bogie frame measured from the middle position with ultimately worn components;

$w_{iR}$  = possible transverse displacement of the bogie pivot and the cradle, measured from the middle position towards the internal side of the curve;

$w_{aR}$  = as  $w_{iR}$ , but towards the outside of the curve;

$w_{iR/aR}$  = 0,020 m, maximum value for speeds less than 30 km/h (UIC 560);

l = maximum track gauge in straight and in considered curved track = 1,544 m;

d = distance between ultimately worn wheel flanges, measured 10mm outwards the running circle = 1,492 m

**▼ B**

R = Curve radius:

for  $h < 600$  mm,  $R = 500$  m,

for  $h \geq 600$  mm,  $R = 150$  m.

t = allowed tolerance (0,020 m) for the displacement of the rail towards the fixed equipment between two maintenance actions.

5. Rules related to the transverse distance between the door and the fixed equipment:

Distance  $OV = L - O_{s/u}$  should be at least 0,020 m.

6. Gauge check

Door gauge check should be carried out on a straight track and on a 500/150-m curve, if value  $w$  varies linearly according to  $1/R$ . Otherwise, the check should be carried out on a straight track and on curve where  $O_{s/u}$  is maximum.

7. Display of the outputs

Formulae used, inserted and resulting values should be displayed in an easily understood manner.

▼ B

FINI/Appendix E

## Pantograph and non-insulated live parts

Figure W.3

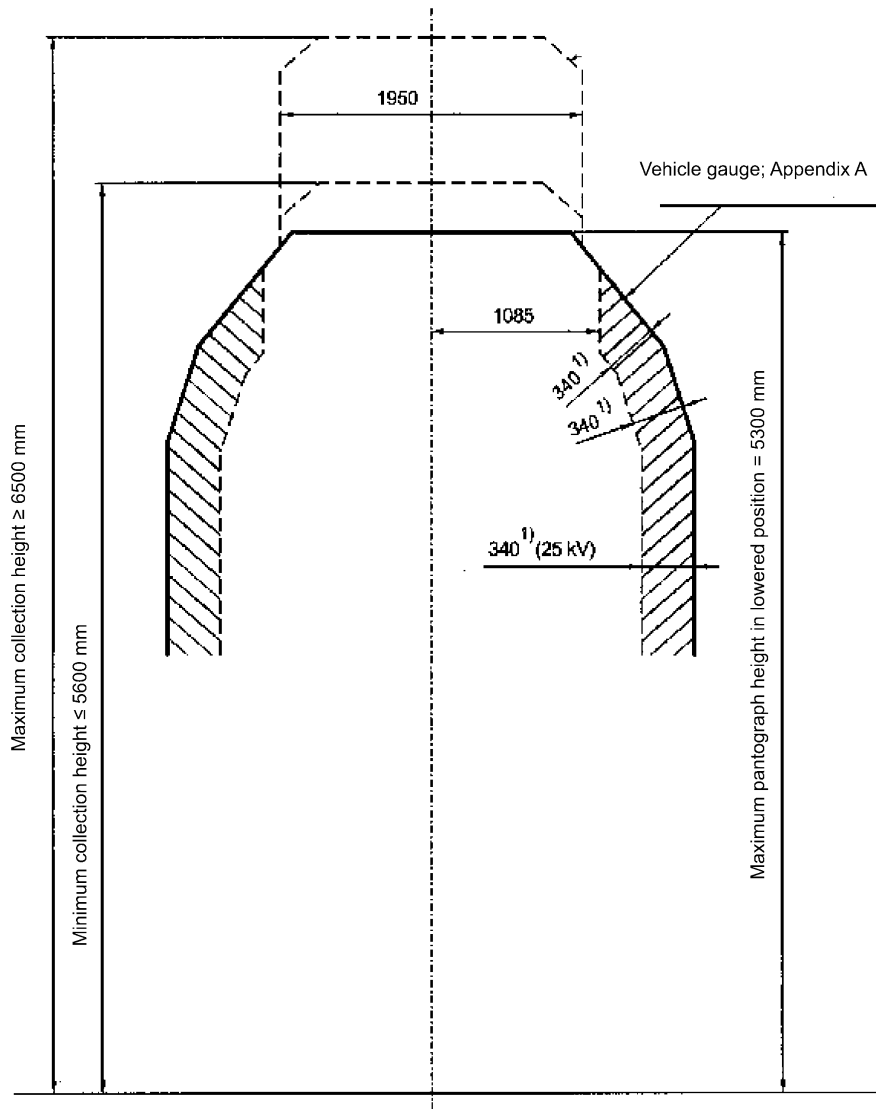

Any non-insulated live part cannot be placed in the dashed area (25 kV).

- 1) Es or Eu must be added in the transversal direction according to Appendix C.

▼B

ANNEX X

SPECIFIC CASES

MEMBER STATE: SPAIN AND PORTUGAL

430-1

PLANCHE 1  
TAFEL 1  
PLATE 1

Essieu monté standard pour transit entre Réseaux à voie large (1,668 - 1,665 m) et à voie normale  
Standardradsatz zum Übergang zwischen Bahnen mit Breitspur (1,668 - 1,665 m) und Bahnen mit Regelspur  
Standard wheelset for wagons exchanged between broad-gauge (1,668 - 1,665 m) and standard-gauge railways

Pour voie normale  
Für Regelspur  
For standard-gauge track

Pour voie large de 1,668 et 1,665 m  
Für Breitspur von 1,668 und 1,665 m  
For broad-gauge track (1,668 m and 1,665 m)

Pour wagon à 2 essieux  
Für zweilachige Güterwagen  
For 2-axle wagons

Pour wagon à bogies et à 2 essieux  
Für Dreigestellgüterwagen und zweilachige Güterwagen  
For 2-axle bogie wagons

Pour wagon à 2 essieux  
Für zweilachige Güterwagen  
For 2-axle wagons

Pour wagon à bogies et à 2 essieux  
Für Dreigestellgüterwagen und zweilachige Güterwagen  
For 2-axle bogie wagons

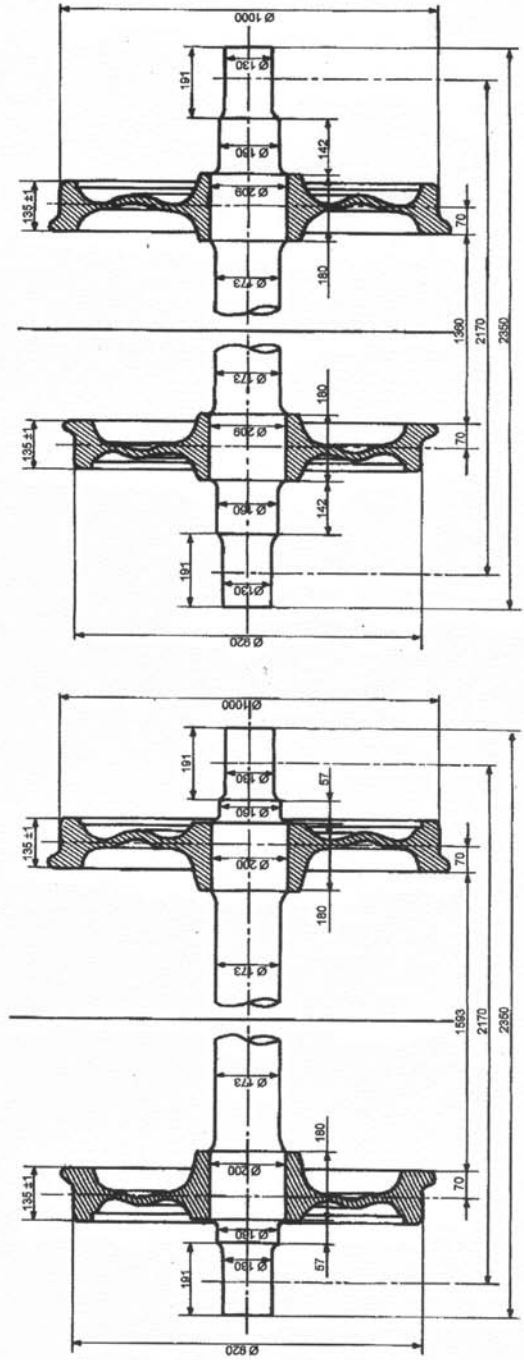

▼B

**Wagon pour transit entre Réseaux à voie large (1,668 - 1,665 m) et à voie normale  
Güterwagen zum Übergang zwischen Bahnen mit Breitspur (1,668 - 1,665 m) und Bahnen mit Regelspur  
Wagon for exchange between broad gauge (1.668 - 1.665 m) and standard-gauge railways**

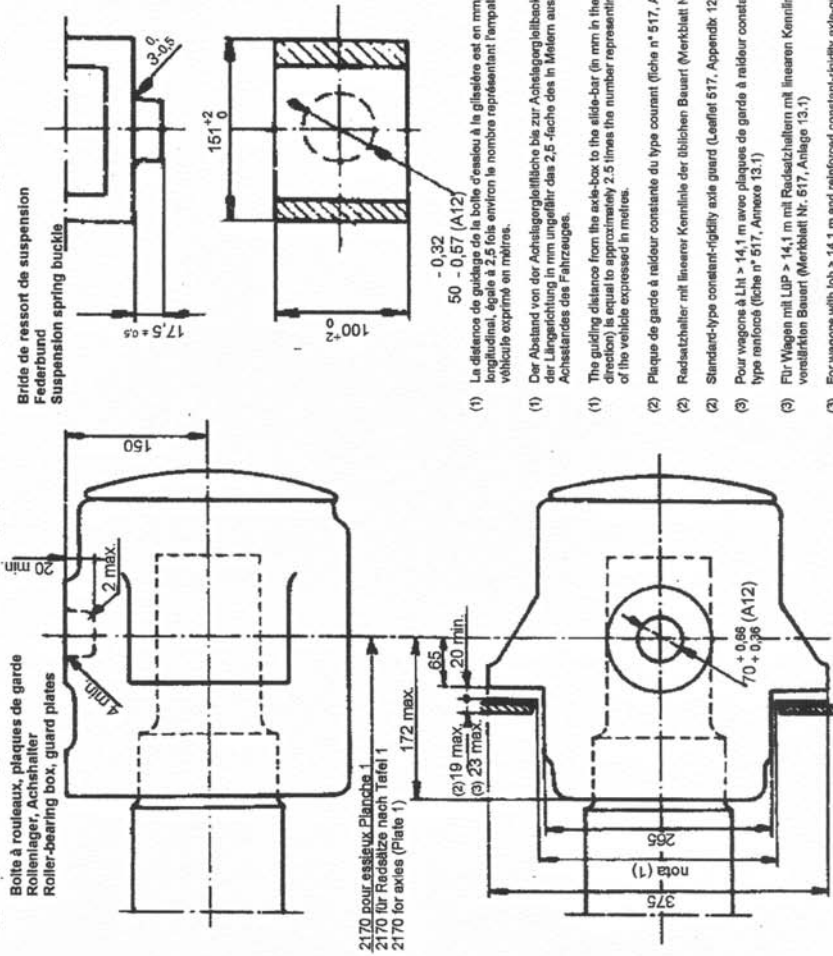

**4 3 0 - 1**  
**PLANCHE 2**  
**TAFEL 2**  
**PLATE 2**

- (1) La distance de guidage de la boîte d'essieu à la glissière est en mm, dans le sens longitudinal. Applique à 2,5 fois environ le nombre représentant l'empattement du véhicule exprimé en mètres.  
Der Abstand von der Achsgehäusebohle bis zur Achsgehäusebohle beträgt in der Längsrichtung in mm ungefähr das 2,5-fache des in Metern ausgedrückten Achsstandes des Fahrzeuges.  
(1) The guiding distance from the axle-box to the slide-bar (in mm in the longitudinal direction) is equal to approximately 2.5 times the number representing the wheel-base of the vehicle expressed in metres.
- (2) Plaque de garde à raidir constante du type courant (fiche n° 517, Annexe 12)  
Radstreifen mit linearer Kennlinie der üblichen Bauart (Merktblatt Nr. 517, Anlage 12)  
(2) Standard-type constant-rigidity axle guard (Leaflet 517, Appendix 12)
- (3) Pour wagons à L<sub>HP</sub> > 14,1 m avec plaques de garde à raidir constants du type renforcé (fiche n° 517, Annexe 13.1)  
Für Waggon mit L<sub>HP</sub> > 14,1 m mit Radstreifen mit linearer Kennlinien der verstärkten Bauart (Merktblatt Nr. 517, Anlage 13.1)  
(3) For wagons with l<sub>ob</sub> > 14,1 m and reinforced constant-rigidity axle-guards (Leaflet 517, Appendix 13.1).

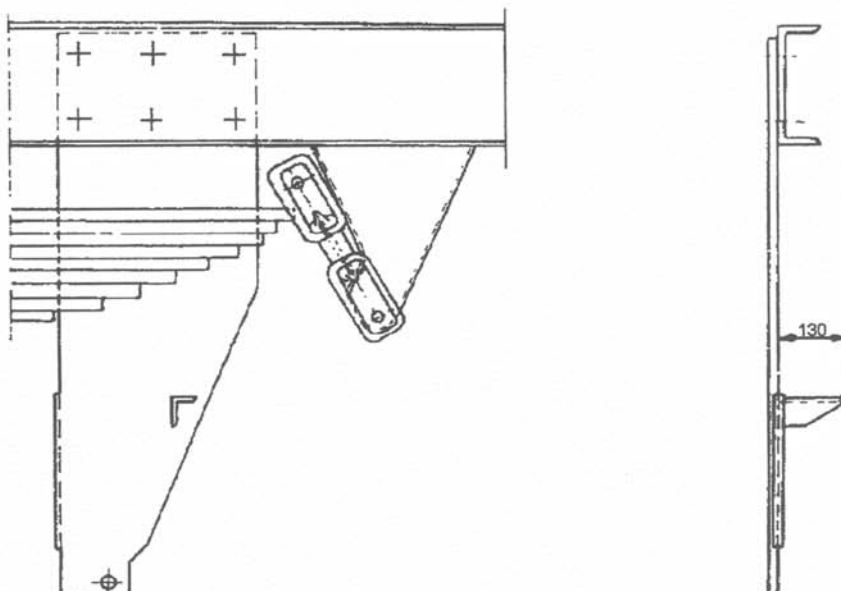
▼B**430 - 1**PLANCHE 3  
TAFEL 3  
PLATE 3**Wagon pour transit entre Réseaux à voie large (1,668 - 1,665 m)  
et à voie normale****Güterwagen zum Übergang zwischen Bahnen mit Breitspur  
(1,668 - 1,665 m) und Bahnen mit Regelspur****Wagon for exchange between broad-gauge (1.668 - 1.665 m)  
and standard-gauge railways****Dispositif de limitation de descente des ressorts**  
**Vorrichtung zur Beschränkung des Heruntergehens der Tragfedern**  
**Device for limiting the descent of the springs**

▼B

Wagon pour transit entre Réseaux à voie large (1,668 - 1,665 m) et à voie normale  
 Güterwagen zum Übergang zwischen Bahnen mit Breitspur (1,668 - 1,665 m) und Bahnen mit Regelspur  
 Wagon for exchange between broad-gauge (1.668 - 1.665 m) and standard-gauge railways

Surface enveloppe des essieux montés  
 Umgrenzungsfläche für die Radsätze  
 Overall surface area of wheel-sets

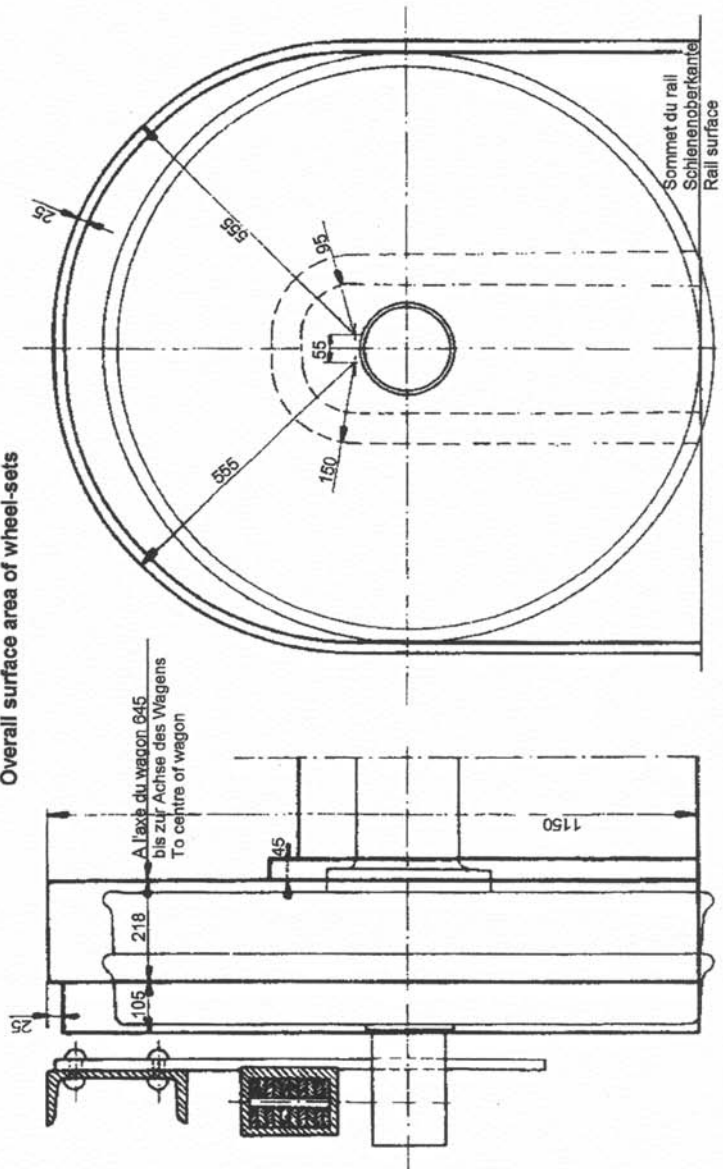

**430-1**  
 PLANCHE 4  
 TAFEL 4  
 PLATE 4

▼B

430-1

PLANCHE 5  
TAFEL 5  
PLATE 5

**Wagon pour transit entre Réseaux à voie large (1,668 - 1,665 m) et à voie normale**  
**Güterwagen zum Übergang zwischen Bahnen mit Breitspur (1,668 - 1,665 m) und Bahnen mit Regelspur**  
**Wagon for exchange between broad-gauge (1,668 -1,665 m) and standard-gauge railways**

**Disposition des sabots de frein**  
**Anordnung der Bremsklötze**  
**Brake-shoe arrangement**

Vagons à roues de 820 mm et de 1 000 mm	
Güterwagen mit 820 mm und 1 000 mm Rädern	
Wagons with 820 mm and 1 000 mm wheels	
Rég. O ou S	Rég. SB
D (1)   Bremsen O oder S (20 t)	Bremsen SS (20 t)
■   O.J.R.3.000/Block	SB.000/Block
37 H 11	41 H 11
44	50
(1) Diamètre de la bague avant l'essai	
(1) Durchmesser der Bogen vor dem Montieren	
(1) Diameter of ring before fitting	

Voies de 1,668 m et 1,665 m  
Breitspur, 1,668 und 1,665 m  
1,668 m and 1,665 m gauge tracks

Voie normale  
Regelspur  
Standard gauge

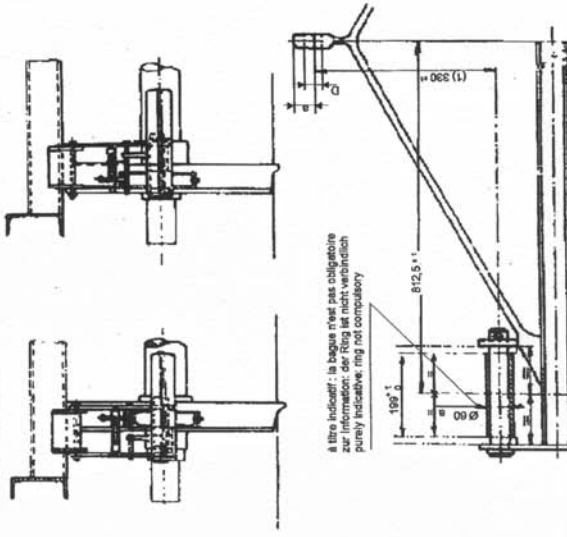

(1) La hauteur de 375 ± 1 mm est aussi admise pour roues de Ø 1 000 mm  
 (1) Die Höhe von 375 ± 1 mm ist auch für Räder mit Ø 1 000 mm erlaubt.  
 (1) The height of 375 ± 1 mm is also admitted for wheels with 1 000 mm Ø.

01.07.97

**Cale de positionnement des portes-soleilles**  
**Keil zur Festlegung der Bremsklötze**  
**Stop-block for positioning brake-shoe holders**

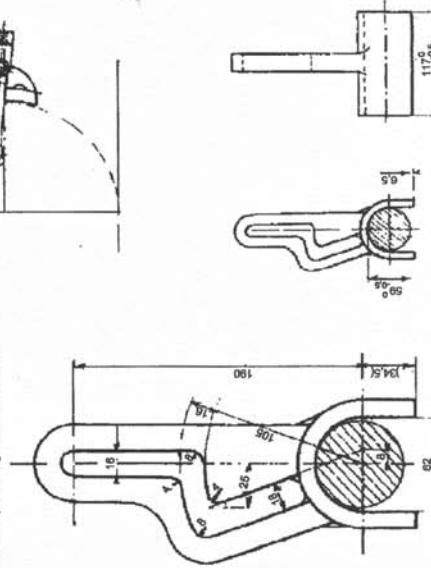



▼B

4 30 - 1  
 PLANCHE 6  
 TAFEL 6  
 PLATE 6

**Wagon pour transit entre Réseaux à voie large (1,668 - 1,665 m) et à voie normale**  
 Espaces libres à réserver sous châssis pour le levage

**Güterwagen zum Übergang Bahnen mit Breitspur (1,668 - 1,665 m) und Bahnen mit Regelspur**  
 Zum Anheben unter dem Untergestell freizuhaltenender Raum

**Wagon for exchange between broad-gauge (1,668 - 1,665 m) and standard-gauge railways**  
 Free space beneath underframe for lifting

Les Réseaux qui le désirent peuvent marquer d'une barre verticale à la peinture blanche l'aplomb des espaces libres sur le brombord  
 Es ist den Bahnen freigestellt, diese freizuhaltenende Stelle am Längsträger durch einen senkrechten Strich mit weißer Farbe zu kennzeichnen  
 Those Railways wishing to do so, can mark this free space on the solebar with a vertical line painted in white

1 - Wagon court à gabarit anglais  
 1 - Kurzer Güterwagen mit englischer Begrenzungslinie  
 1 - British-gauge short wagon

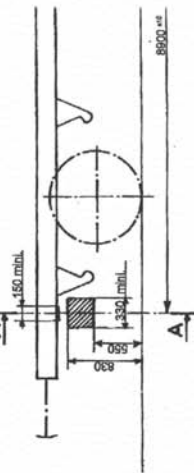

Section A-A  
 Schnitt A-A  
 Cross-section A-A

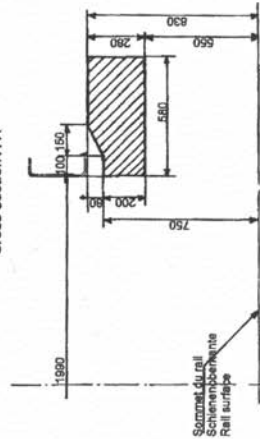

Nota :

Les parties hachurées représentent les espaces libres à réserver à proximité immédiats des supports extrêmes de suspension pour le passage des bacs de vérins.

Anmerkung : Die schraffierte Teile stellen den in unmittelbarer Nähe der äußeren Federböcke freizuhaltenenden Raum für den Durchgang der Windenarme dar.

Note : The shaded portions indicate the free spaces to be left unobstructed in the immediate vicinity of the end suspension spring brackets for engaging the lifting jack head.

2 - Wagon long à gabarit continental  
 2 - Langer Güterwagen mit kontinentaler Begrenzungslinie  
 2 - Continental-gauge long wagon

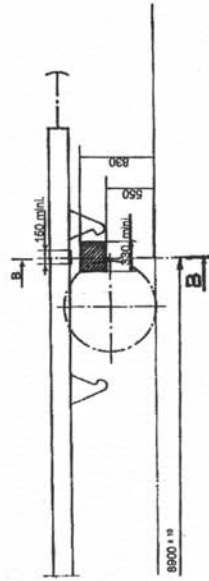

Section B-B  
 Schnitt B-B  
 Cross-section B-B

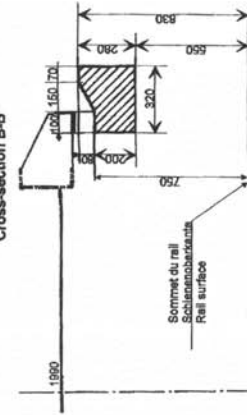

▼ B

4 3 0 - 1  
 PLANCHE 7  
 TAFEL 7  
 PLATE 7

Encombrement - Enveloppe du bogie apte au transit entre Réseaux à voie large (1,668 - 1,665 m) et à voie normale  
 Hüllraumbeanspruchung des für den Übergang zwischen Breitspur (1,668 - 1,665 m) und Regelspur geeigneten Drehgestells  
 Overall dimensions of bogie suitable for exchange between broad-gauge (1,668 - 1,665 m) and standard-gauge railways

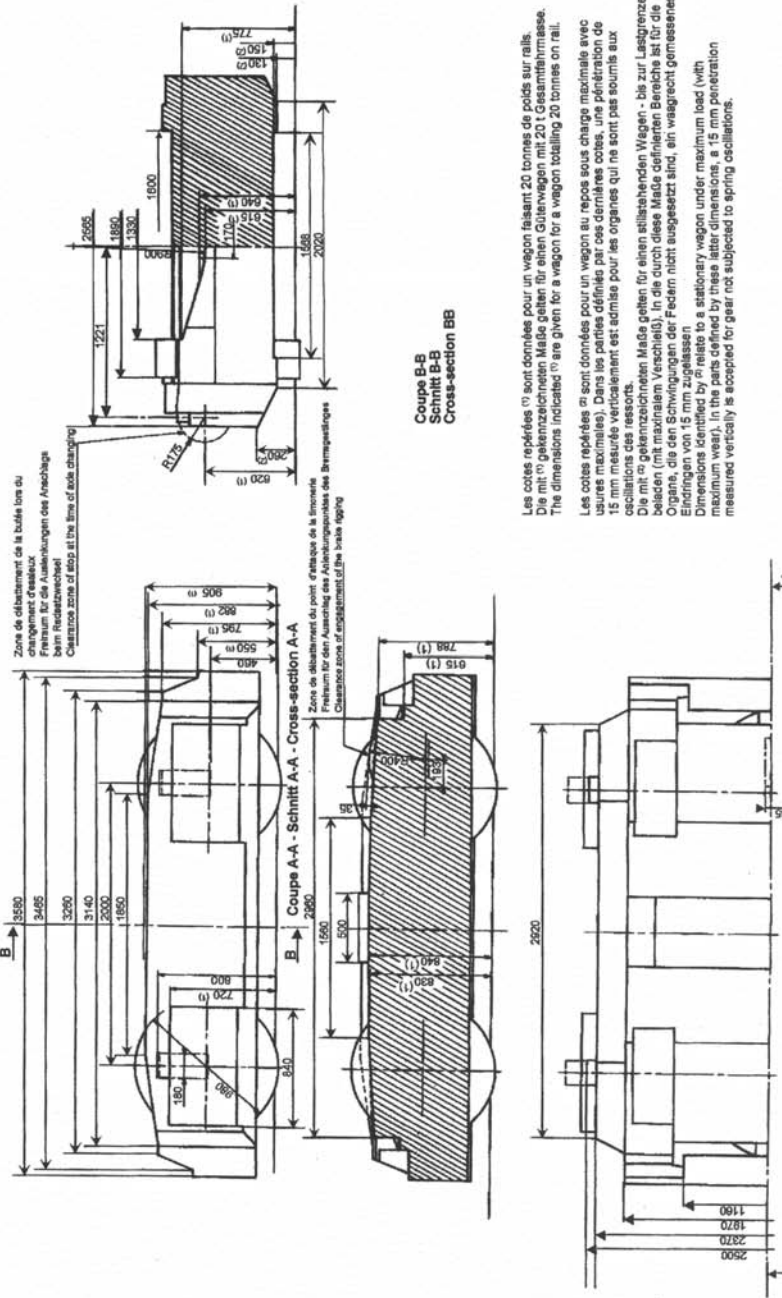

Les cotes répétées (1) sont données pour un wagon faisant 20 tonnes de poids sur rails.  
 Die mit (1) gekennzeichneten Maße gelten für einen Güterwagen mit 20 t Gesamtfrachtmasse.  
 The dimensions indicated (1) are given for a wagon for a wagon totalling 20 tonnes on rail.

Les cotes répétées (2) sont données pour un wagon au repos sous charge maximale avec usures maximales). Dans les parties définies par des dernières cotes, une pénétration de 15 mm mesurée verticalement est admise pour les organes qui ne sont pas soumis aux oscillations des ressorts.  
 Die mit (2) gekennzeichneten Maße gelten für einen stillstehenden Wagen - bis zur Lastgrenze beladen (mit maximalen Verschleiß). In die durch diese Maße definierten Bereiche der Bauteile, die den 15 mm gemessenen Feder nicht ausgesetzt sind, ein waagrecht gemessenes Maximum von 15 mm Penetration ist zulässig.  
 Dimensions identified by (2) relate to a stationary wagon under maximum load (with maximum wear). In the parts defined by these latter dimensions, a 15 mm penetration measured vertically is accepted for gear not subjected to spring oscillations.

▼B

**430-1**

PLANCHE 8  
TAFEL 8  
PLATE 8

Montage du pivotement  
Gestaltung des Drehpunktes  
Pivoting assembly

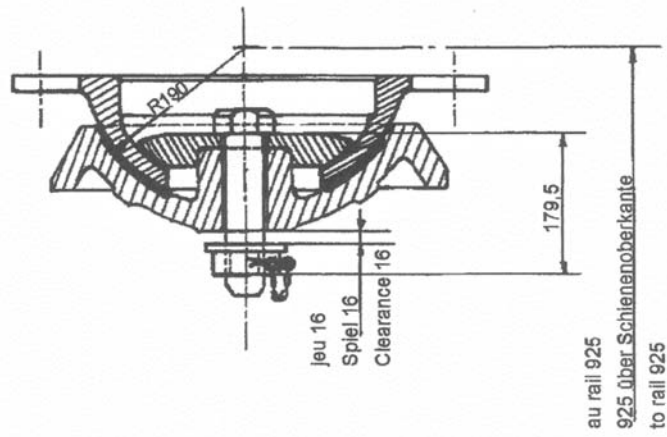

▼B**4 3 0 - 1**

PLANCHE 9

TAFEL 9

PLATE 9

**Wagon pour transit entre Réseaux à voie large (1,668 - 1,665 m)  
et à voie normale**

**Güterwagen zum Übergang zwischen Bahnen mit Breitspur  
(1,668 - 1,665 m) und Bahnen mit Regelspur**

**Wagon for exchange between broad-gauge (1.668 - 1.665 m)  
and standard-gauge railways**

**Boîte d'essieu pour bogies de wagons  
Achslager für Drehgestelle-Güterwagen  
Axle-box for wagon bogies**

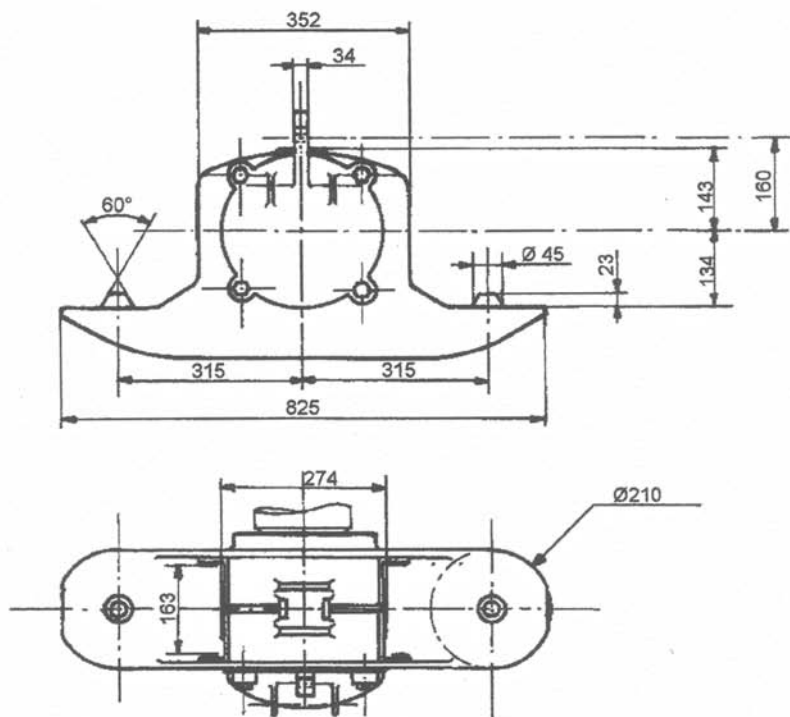

▼B

**430-1**

PLANCHE 10  
TAFEL 10  
PLATE 10

**Dispositif de retenue des organes de suspension lors  
du changement des essieux**  
**Vorrichtung zur Befestigung der Federung beim Radsatzwechsel**  
**Suspension-gear holding device during axle-changeover**

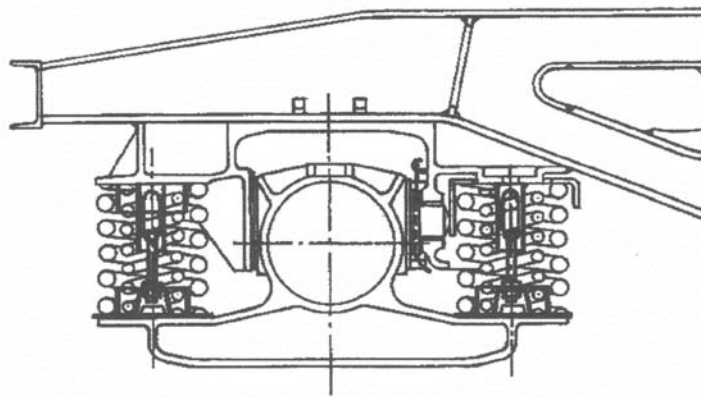

Note : Le nouveau dispositif de retenue se fait par un ressort.

Anmerkung: Die neue Vorrichtung zur Befestigung der Federung macht sich durch eine Feder.

N.B.: The new holding device is of the spring type.

▼B

430-1

PLANCHE 11  
TAFEL 11  
PLATE 11

**Dispositif de sécurité rabattable reliant l'essieu au châssis de bogie**  
**Abklappbare Sicherheitsvorrichtung zur Verbindung des Radsatzes**  
**mit dem Drehgestellrahmen**  
**Retractable safety device linking axle to bogie frame**

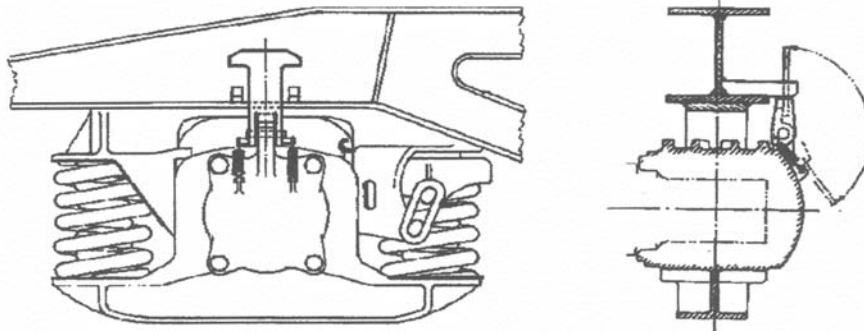

▼B

**Wagons à bogies - Drehgestellgüterwagen - Bogie wagons**  
**Disposition des sabots de frein - Anordnung der Bremsklötze - Brake-shoe arrangement**

Vole normale - Regelspur - Standard-gauge track Voies de 1,668 m et 1,665 m - Broad-gauge track (1,668 m and 1,665 m)

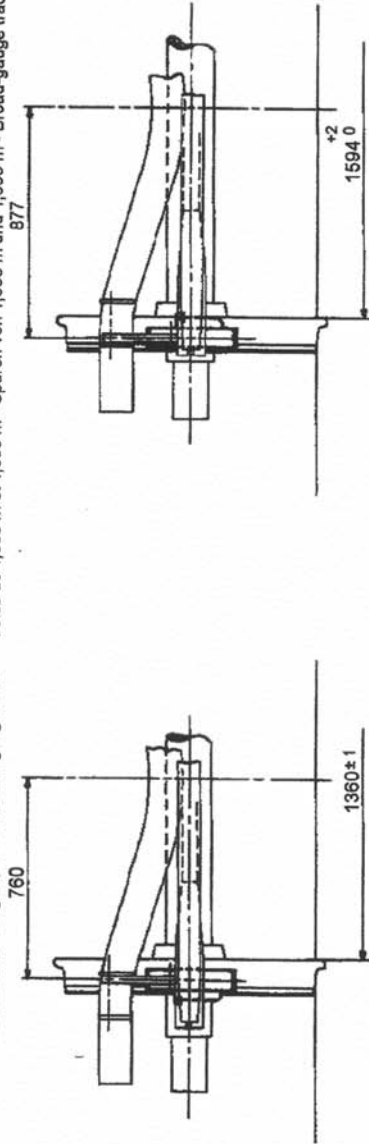

Wagons à roues de 920 mm Güterwagen mit Rädern von Ø 920 mm Wagons with Ø 920 mm wheels		Régime SS Bremsart SS (20 t) O or S conditions SS conditions	
D	37 H 11	44	41 H 11
a	44	50	50

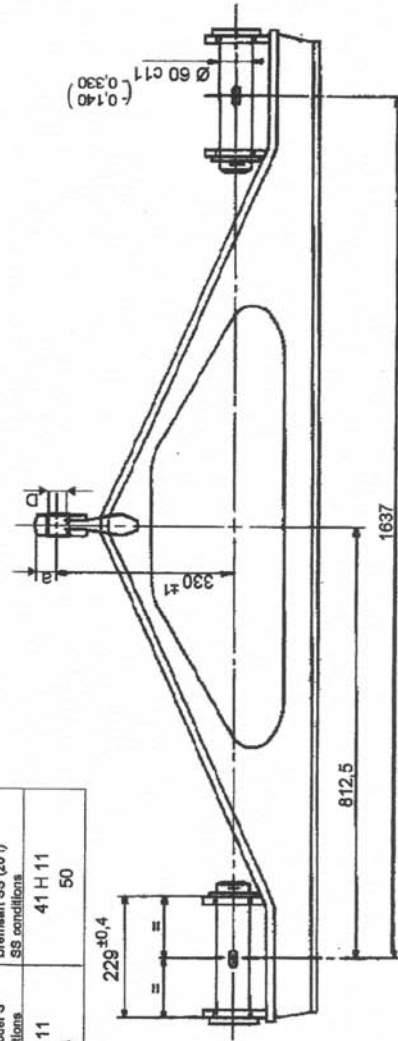

**430-1**

PLANCHE 12  
 TAFEL 12  
 PLATE 12

01.07.97

▼ B

4 3 0 - 1

PLANCHE 13  
TAFEL 13  
PLATE 13

**Implantation des vérins de levage sur les chantiers**  
**Anordnung der Hebewinden auf den Anlagen**  
**Positioning of lifting jacks on work sites**

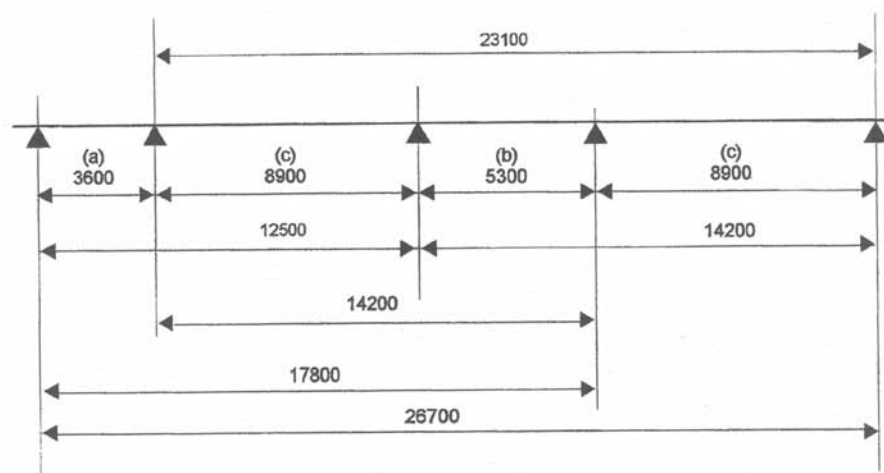

Distances utilisables des appuis de levage  
Vorgesehene Abstände der Auflageplatten  
Working distances of lifting-jack supports/bearings

$$\begin{aligned}
 a &= 3\,600 \\
 b &= 5\,300 \\
 c &= 8\,900 \\
 a + c &= 12\,500 \\
 b + c &= 14\,200 \\
 a + b + c &= 17\,800 \\
 b + 2c &= 23\,100^{(1)}
 \end{aligned}$$

<sup>(1)</sup> Distance valable seulement pour les wagons à 3 essieux transport d'automobiles.

<sup>(1)</sup> Dieser Abstand gilt nur für dreiachsige Wagen für Autotransport.

<sup>(1)</sup> Distance valid exclusively for 3-axle car-carrying wagons.



▼ B

430-1

PLANCHE 14  
TAFEL 14  
PLATE 14

**Wagon à bogies pour transit entre : Réseaux à voie large (1,668 - 1,665 m) et à voie normale  
Drehgestellgüterwagen für den Übergang von Breitspur (1,668 - 1,665 m) auf Regelspur  
Bogie wagon for exchange between broad-gauge (1,668 - 1,665 m) and standard-gauge railways**

Dispositif de liaison entre châssis de wagon et châssis de bogie pour effectuer le levage  
Verbindungsrichtung zwischen Wagenuntergestell und Drehgestellrahmen beim Heben  
Wagon underframe - bogie frame connecting device for lifting purposes

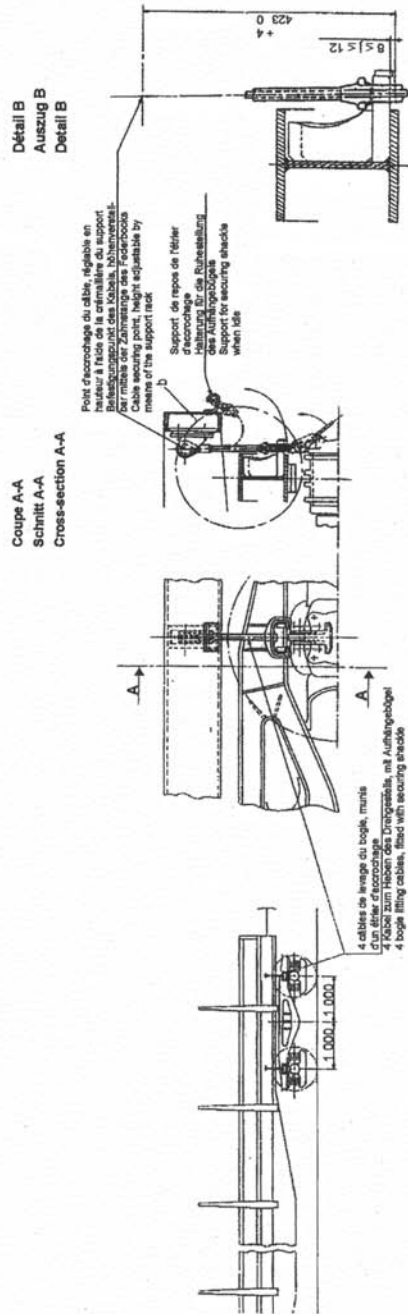

Note: Le jeu "J" devra être respecté à la sortie du wagon ou à l'occasion d'un changement de bogie lors d'une opération d'entretien  
Anmerkung: Das Spiel "J" muß bei der Lieferung des Wagens beziehungsweise beim Auswechseln des Drehgestells anlässlich eines Unterhaltungsvorgangs eingehalten werden.  
Note: Clearance "J" must be observed on placing of the wagon in service or when bogie changeover during on the occasion of bogie changing during maintenance operations.



▼ B

**Toles pare-étincelles pour wagons à essieux - Funkenschutzbleche für zweiachsige Güterwagen**  
**Spark-arrester shields for axle wagons**

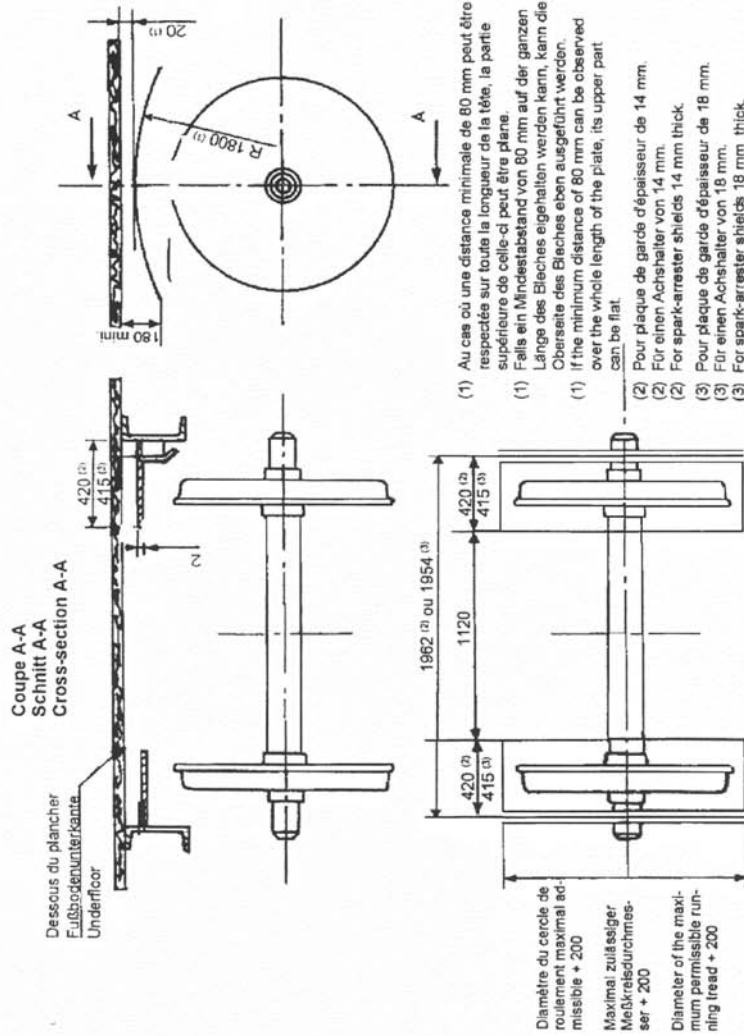

- (1) Au cas où une distance minimale de 80 mm peut être respectée sur toute la longueur de la tête, la partie supérieure de celle-ci peut être plane
- (1) Falls ein Mindestabstand von 80 mm auf der ganzen Länge des Bleches eingehalten werden kann, kann die Oberseite des Bleches eben ausgeführt werden.
- (1) If the minimum distance of 80 mm can be observed over the whole length of the plate, its upper part can be flat.
- (2) Pour plaque de garde d'épaisseur de 14 mm.
- (2) Für einen Achshalter von 14 mm.
- (2) For spark-arrester shields 14 mm thick.
- (3) Pour plaque de garde d'épaisseur de 18 mm.
- (3) Für einen Achshalter von 18 mm.
- (3) For spark-arrester shields 18 mm thick.

Note: Pour des raisons de proximité des roues de l'essieu à voie large au châssis, la disposition des tibias pare-étincelles ne peut pas être réalisable dans les formes et dimensions décrites aux Annexes 1 et 2 de la fiche n° 543

Anm.: Aufgrund der Nähe zwischen den Rädern des Breitspurradatzes und dem Untergestell, können die Anordnungen der Funkenschutzbleche die Bedingungen der Anlagen 1 und 2 zum UIC-Merkblatt Nr. 543 nicht einhalten.

N.B.: Because the wheels of broad-gauge axles are close to the underframe, the layout of spark-arrester shields cannot be made to comply with the shapes and dimensions specified in Appendices 1 and 2 to Leaflet 543.

**4 3 0 - 1**

PLANCHE 16  
 TAFEL 16  
 PLATE 16

▼B

**4 3 0 - 1**

**Tôles pare-étincelles pour wagons à bogies**  
**Funkenschutzbleche für Güterwagen mit Drehgestellen**  
**Spark-arrester shields for bogie wagons**

*PLANCHE 17*  
*TAFEL 17*  
*PLATE 17*

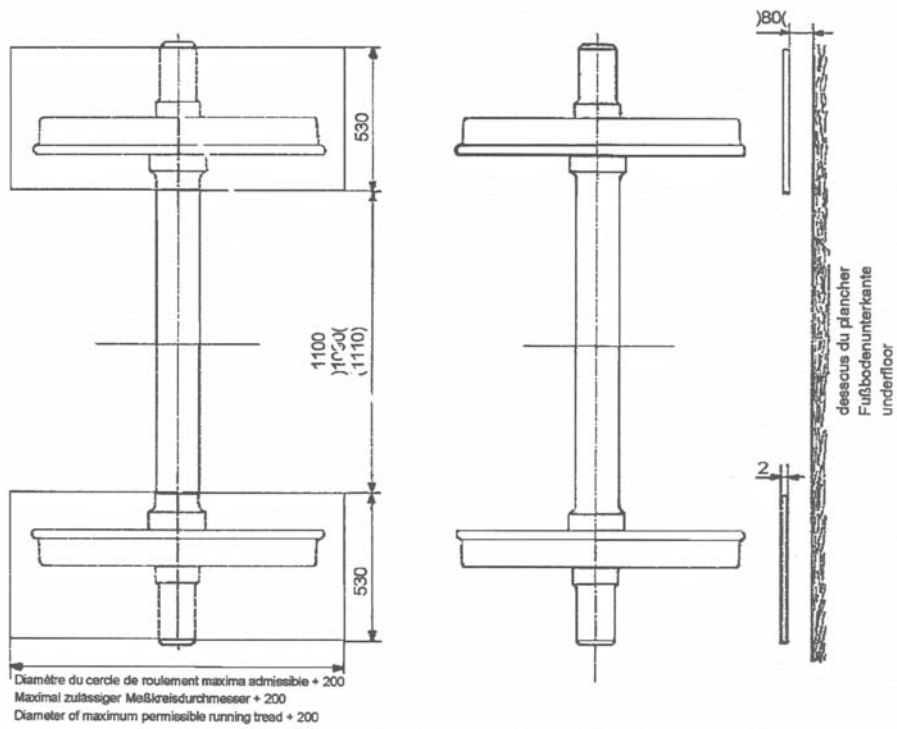

▼B

**430-1**

PLANCHE 18  
TAFEL 18  
PLATE 18

**Etrier pour plaque de garde à 18 mm**  
**Bügel für einen Achshalter von 18 mm**  
**Stirrup for 18 mm half-axle guard**

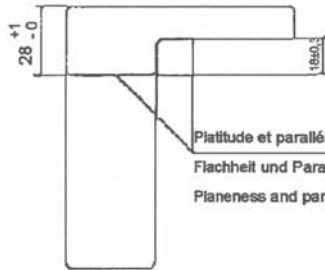
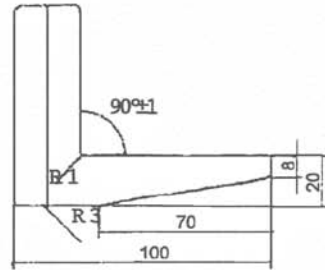
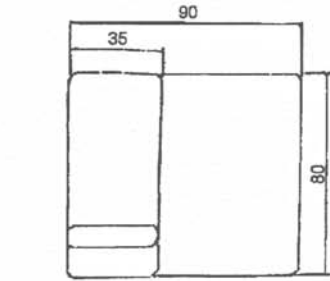

Platitudo et parallélisme : ± 0,5  
Flachheit und Parallelismus: ± 0,5  
Planeness and parallelism ± 0,5

**Etrier pour plaque de garde à 14 mm**  
**Bügel für einen Achshalter von 14 mm**  
**Stirrup for 14 mm half-axle guard**

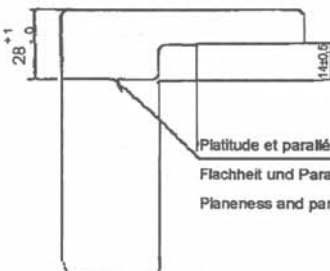
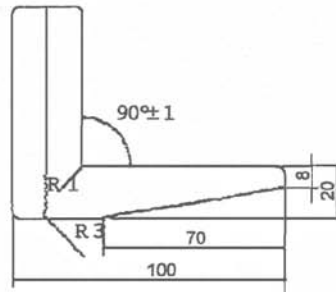
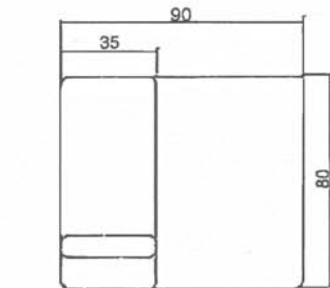

Platitudo et parallélisme : ± 0,5  
Flachheit und Parallelismus: ± 0,5  
Planeness and parallelism ± 0,5

01.07.97

▼B

5 10 - 1

Essieux montés munis de boîtes à rouleaux pour ressorts à lames - Standardisation  
 Radsätze mit aufgesattelten Rollenlagern für Blattfedern - Standardisierung  
 Wheelsets fitted with roller bearing axle boxes for leaf springs - Standardisation

ANWEXE 3  
 ANLAGE 3  
 APPENDIX 3

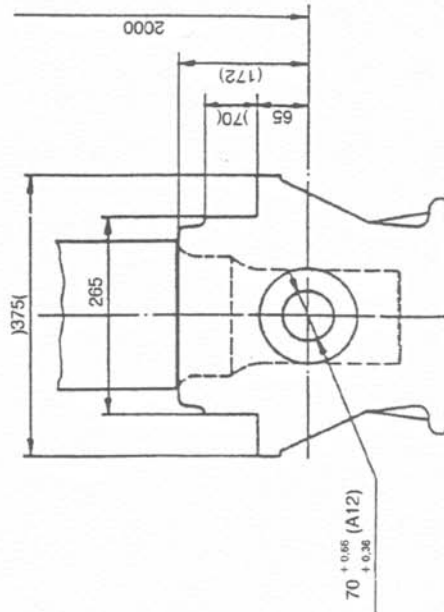
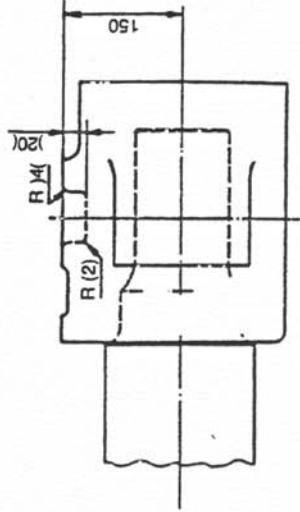
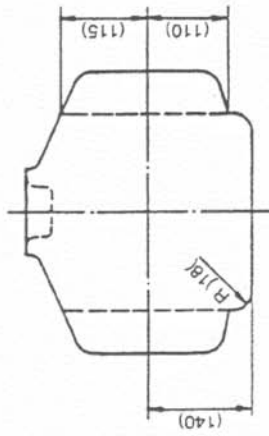

( )  
 Cotes les plus grandes admises  
 Höchstzulassung  
 Greatest permissible dimensions

Cotes les plus petites admises à l'état neuf  
 Mindestmaße im Neuzustand  
 Smallest permissible dimensions when new



## ANNEX Y

## CONSTITUENTS

## Bogies and Running Gear

Bogies with existing approval under former UIC/RIV-regulation are considered as IC, provided the range of applicable parameters in the new application (including those of the vehicle body) remain within the range already proved by an existing application.

Existing approved bogies under former national regulation are considered as IC, if the national regulation used former UIC-regulation, provided the range of applicable parameters in the new application (including those of the vehicle body) remain within the range already proved by an existing application.

The tables below contain a list of bogies, that can be considered under the above criteria.

## Special remark

Freight wagons are suitable for running speed  $V_{max} \leq 120$  km/h with their maximum design load (even if the brake performance at maximal load is not sufficient) when they fulfil the following technical parameters:

— Two-axle wagons:

Tare:	$\geq 10$ t
Wheelbase:	$2a^* \geq 6,0$ m $2a^* \geq 8,0$ m by wagons fitted with double link suspension
Design requirements of the suspensions:	according to the types of suspensions in the following table Y4

— Bogie wagons

Tare	$\geq 16$ t
Design requirements of the bogies:	according to the types of bogies in the following tables Y1 and Y3

## Y.1 TWO AXLE BOGIES

Table Y.1: Two-axle bogies for wagons operating up to 100km/h

Type of Bogie	Max. Wheelset Load [kN]
K17, Y25TTV, Y21 Pse, DRRS25	245 (25 t)
K16, Y25 Lstm, Y25 Lst, Y25 Lsodm, Y25 Lsif, Y25 Lsi, Y25 Ls(s)i1, Y25 Ls(s)i2, Y25 Ls(s)i1f, Y25 Ls(s)i2f, Y25 Lsdm, Y25 Lsd2i, Y25 Lsd2, Y25 Lsd1, Y25 Ls(s)m, Y25 Ls(s), Y21 Lsedm, Y21Lse, K16, FS 46 Lssi, FS 46 Lsi, Y25 L(s)1, DRRS DB 628, DB 629, DB 641, DB 642, DB 643, DB 645, DB 646, DB 651, DB 652, DB 653, DB 655, DB 656, DB 665, DB 680, DB 681, DB 682, DB 683, DB 685, DB 868, DB 672 (DRRS), DB 882, DB 885 DB 094, DB 095, DB 097, DB 556, DB 565, DB 573, DB 574, DB 575, DB 578, DB 579, DB 583, DB 584, DB 585, DB 586, DB 587, DB 588, DB 589, DB 592	220 (22,5 t)

## ▼B

Type of Bogie	Max. Wheelset Load [kN]
Y27 E2, Y27 E1m, Y27 E1, Y27 E, Y27 Cm1, Y27 C1, Y25 Rstm, Y25 Rst, Y25 Rsm, Y25 Rsimf, Y25 Rsim, Y25 Rsif, Y25 Rsif, Y25 Rsi, Y25 Rs2m, Y25 Rs2, Y25 Rsa, Y25 Rs, Y25 Lsod1, Y25 Cstm, Y25 Cst, Y25 Csm, Y25 Csimf, Y25 Csim, Y25 Csif, Y25 Csi, Y25 Cs2m, Y25 Cs2, Y25 Cs1m, Y25 Cs1, Y25 Cst1, Y25 Cs, Y25 Cm1, Y25 Cm, Y25 C1, Y25 C, Y21 Csei, Y21 Cse, G56, G66, G66M, G66P, G691, G692, G693, G694, G70, G70M, G70P, G70T, G75, G771, Y25Cssi, Y21 Rse DB 621, DB 622, DB 625, DB 640, DB 650, DB 684, DB 839, DB 851, DB 852, DB 853, DB 859, DB 864, DB 866, DB 867, DB 871, DB 872, DB 881, DB 887, DB 931, DB 932 DB 096, DB 550, DB 551, DB 552, DB 553, DB 554, DB 555, DB 560, DB 561, DB 562, DB 563, DB 566, DB 567, DB 572, DB 576, DB 577, DB 581, DB 590, DB 591	196 (20 t)
Y33 Am, Y33 A, Y27 D, Y27 Cm, Y27 C, Y25 D, Y23 Cm, Y23 C, Y21 C, DB 582,	176 (18 t)
Y31 C1, FS 38i DB 631, DB 707	157 (16 t)
Y 29	147 (15 t)
DB 741	93 (9,5 t)
DB 690	74 (7,5 t)

Table Y.2: Two-axle bogies for wagons operating up to 120 km/h

Type of Bogie	Max. Wheelset Load [kN]
K17, Y 25 LD, Y 27 LDm, DRRS, 4RS/N, WU83, Y25Lss, Y21Ls(s)e DB 624, DB 626, DB 627, DB 644, DB 654, DB 666 DB 557	220 (22,5 t)
K16, Y21 Csse, Y21 Cs(s)e, Y25 Css, Y25 Cssm, Y25 Cssp, Y25 GVrss, Y25 Ls(s), Y25 Ls(s)i1, Y25 Ls(s)i2, Y25 Ls(s)i1f, Y25 Ls(s)i2f, Y25 Ls(s)m, Y25 Rss, Y25 Rssa, Y25 Rssm, Y 25 RSSd1, 1XTamp, 6TNa, 6TNa/1, G884 DB 672 (DRRS) DB 564	196 (20 t)
Y37 B, FS 46 Lssi	176 (18 t)
Y33 A, Y33Am	167 (17 t)
Y25 D, Y27 D, Y31 A, Y31B, Y31C	157 (16 t)
Y31 C1, FS 38i	127 (13 t)

NOTE: For bogies of the family Y25 (Y21, Y27, Y31, Y35, and Y37) there are only versions with elastic side bearers.

Table Y.2.1: Two-axle bogies for wagons operating up to 140 km/h

Type of Bogie	Max. Wheelset Load [kN]
DB 627.1	196 (20 t)
Y 25 LD, Y 27 LDm	176 (18 t)



**▼B**

Type of Bogie	Max. Wheelset Load [kN]
Y27 D1, Y31B1, Y31B2	157 (16 t)
Y33 A, Y33 Am, Y 35 B	137 (14 t)

*NOTE:* For bogies of the family Y25 (Y21, Y27, Y31, Y35, and Y37) there are only versions with elastic side bearers.

*Table Y.2.2: Two-axle bogies for wagons operating up to 160 km/h*

Type of Bogie	Max. Wheelset Load [kN]
Y 37 A DB 675 (DRRS)	176 (18 t)
Y25GVr, Y37B	157 (16 t)
Y30	98 (10 t)

*NOTE:* For bogies of the family Y25 (Y21, Y27, Y31, Y35, and Y37) there are only versions with elastic side bearers.

*Table Y.3: Three-axle bogies for wagons operating up to 100 km/h*

Type of Bogie	Max. Wheelset Load [kN]
DB 715, DB 716, DB 816, DB 817	245 (25 t)
DB 713, DB 714	220 (22,5 t)
DB 710, DB 711	196 (20 t)

## Y.2 SUSPENSION

*Table Y.4: Suspensions for two axle wagons*

Type of Suspension	Max speed [km/h]	Max. Wheelset Load [kN]
Niesky 2	100	245 (25 t)
UIC double link suspension (*)	120	220 (22,5 t)
Niesky 2	120	220 (22,5 t)
S 2000 (**)	120	220 (22,5 t)

(\*) This suspension can be used on wagons with a wheelbase of  $\geq 8$  m only.

(\*\*) Subject to approval by UIC before the coming into force of this TSI.



## ANNEX Z

## STRUCTURE AND MECHANICAL PARTS

## Impact (Buffing) Test

## Z.1. BUFFING TESTS

## Z.1.1. Requirement

An unbraked wagon standing on level straight track shall be capable, both when empty and laden, of withstanding the buffing shock resulting from impact by a wagon with a total laden weight on rail of 80 t and fitted with side buffers with a buffer energy storage capacity  $\geq 30$  kJ <sup>(1)</sup>. A difference in the height of buffers (empty and laden condition) of max. 50mm can be tolerated.

## Z.1.2. Buffing tests with empty wagons

The tests shall be carried out with an increasing speed up to 12 km/h <sup>(2)</sup>. Between the speeds from 8 to 12 km/h an acceleration curve ( $x = f(v)$ ) shall be recorded. The number of impacts can be limited.

## Z.1.3. Buffing test with laden wagons

For this test, the wagon shall be loaded to its maximum capacity. The direction of impact shall be reversed after each buffing impact except in the case of tank wagons. Buffing impact tests need not be undertaken for conventional flat wagons.

## Z.1.4. Wagons with side buffers

Preliminary tests are to be carried out with an increasing speed of impact. These preliminary tests shall be continued until one of two parameters (speed or force) attains the limiting values fixed in the following table.

40 identical buffing impacts shall then be carried out with this limit in force.

The preliminary tests and the series of buffing tests shall be conducted under the following conditions:

Table Z1

Limiting values		Preliminary tests	Test series
Force per buffer	Buffing speed		
1 500 kN <sup>(3)</sup> <sup>(4)</sup> . at a buffing speed $\leq 12$ km/h	12 km/h <sup>(5)</sup> .	10 buffing impacts at progressively increasing speeds up to 12 km/h, three of which with a speed of approximately 9 km/h. However, if an impact force per buffer of 1 500 kN is attained at a speed $< 12$ km/h, the speed shall not be increased above this value.	40 buffing impacts at the limit speed defined during the preliminary tests, viz: — either 12 km/h, — or the speed corresponding to a buffing force of 1 500 kN <sup>(5)</sup> <sup>(6)</sup> <sup>(7)</sup> .

Notes:

- <sup>(1)</sup> Recommendations concerning the type of buffer to be selected for different types of wagon are given in ERRI technical document DT 85 sheet B 3.0
- <sup>(2)</sup> Unless otherwise stated in the standard conditions and contract. In particular, with certain wagons, which are unacceptable for shunting on the gravity hump or for fly-shunting (i.e. type F-II), the buffing speed can be limited to 7 km/h.
- <sup>(3)</sup> The permissible tolerance on the buffer force at one end of the wagon is  $\pm 200$  kN, but the total force on both buffers shall not exceed 3 000 kN.

**▼B**

- (4) If the wagon tested is equipped with buffers of category C, the limiting value of the buffer force can, subject to the agreement of the operator concerned, be reduced to 1 300 kN (with a buffing speed < 12 km/h) This does not apply to tank wagons intended for the transport of dangerous goods category 2 of the RID regulations. These are to be tested fitted with category A buffers.
- (5) If the value of the buffer force already reaches 1 000 kN for a buffing speed < 9 km/h, the wagon to be tested shall be equipped with higher capacity buffers.
- (6) If requested by the operator, buffing tests with a force above 1 500 kN and a speed of up to 12 km/h can be carried out at the end of the tests.
- (7) For wagons with hydrodynamic long-stroke shock absorbers the limiting value of the buffer force is reduced to 1 000 kN.

**Z.1.5. Wagons equipped with an automatic coupler**

The buffing speed of 12 km/h shall in all cases be obtained.

**Z.1.6. Results**

The different buffing tests shall not result in any visible permanent deformations. The stresses occurring at certain critical points of the bogie/underframe, underframe/body and superstructure connections shall be recorded.

The results obtained shall satisfy the following conditions:

- The cumulative residual strains arising from the preliminary test and from the series of 40 buffing impacts shall be less than 2 ‰ and shall be stabilised before the 30<sup>th</sup> impact of the series. This does not apply however to those structural components covered by special provisions.
- The variations in leading dimensions shall not impair the quality of use of the wagon.



ANNEX AA

**ASSESSMENT PROCEDURES**

**Verification of Subsystems**

**Structure of modules for the EC verification procedure of Subsystems**

**Modules for the EC verification of subsystems**

- Module SB: Type examination
- Module SD: Product quality management system
- Module SF: Product verification
- Module SH2: Full quality management system with design examination

MODULES FOR THE EC VERIFICATION OF SUBSYSTEMS

*Module SB: Type Examination*

1. This module describes the EC verification procedure whereby a notified body checks and certifies at the request of an contracting entity or its authorised representative established within the Community, that a type of a Rolling Stock Freight wagon subsystem, representative of the production envisaged,
  - complies with this TSI and any other applicable TSI, which demonstrate that the essential requirements <sup>(1)</sup> of Directive 2001/16/EC <sup>(2)</sup> have been met
  - complies with the other regulations deriving from the Treaty.

The type examination defined by this module could include specific assessment phases — design review, type test or review of manufacturing process, which are specified in the relevant TSI.
2. The contracting entity <sup>(3)</sup> must lodge an application for EC verification (through type examination) of the subsystem with a notified body of his choice. The application must include:
  - name and address of the contracting entity or its authorised representative
  - the technical documentation, as described in point 3.
3. The applicant must place at the disposal of the notified body a specimen of the subsystem <sup>(4)</sup>, representative of the production envisaged and hereinafter called 'type'.

A type may cover several versions of the subsystem provided that the differences between the versions do not affect the provisions of the TSI.

The notified body may request further specimens if needed for carrying out the test programme.

If so required for specific test or examination methods and specified in the TSI or in the European specification <sup>(5)</sup> referenced to in the TSI, a specimen or specimens of a subassembly or assembly or a specimen of the subsystem in a pre-assembled condition shall to be provided.

The technical documentation and specimen(s) must enable the design, manufacture, installation, maintenance and operation of the subsystem to be understood, and shall enable conformity with the provisions of the TSI to be assessed.

<sup>(1)</sup> The essential requirements are reflected in the technical parameters, interfaces and performance requirements, which are set out in Chapter 4 of the TSI.

<sup>(2)</sup> This module could be used in the future when the TSIs of the HS directive 96/48/EC are updated.

<sup>(3)</sup> In the module, 'the contracting entity' means 'the subsystem contracting entity, as defined in the directive, or his authorised representative established within the Community'.

<sup>(4)</sup> The relevant section of a TSI may define specific requirements in this regard.

<sup>(5)</sup> The definition of an European specification is indicated in the directives 96/48/EC and 01/16/EC. The guide for application of HS TSIs explains the way to use the European Specifications

**▼B**

The technical documentation must include:

- a general description of the subsystem, overall design and structure,
- *the Rolling Stock register, including all information as specified in the TSI*
- conceptual design and manufacturing information, for example drawings, schemes of components, subassemblies, assemblies, circuits, etc.,
- descriptions and explanations necessary for the understanding of the design and manufacturing information, the maintenance and the operation of the subsystem,
- the technical specifications, including European specifications, that have been applied,
- any necessary supporting evidence for the use of the above specifications, in particular where European specifications and the relevant clauses have not been applied in full,
- a list of the interoperability constituents to be incorporated into the subsystem,
- copies of the EC declarations of conformity or suitability for use of interoperability constituents and all the necessary elements defined in annex VI of the directives,
- evidence of conformity with regulations deriving from the treaty (including certificates)
- technical documentation regarding the manufacture and the assembly of the subsystem,
- a list of manufacturers, involved in the subsystem's design, manufacturing, assembly and installation,
- conditions for use of the subsystem (restrictions of running time or distance, wear limits etc),
- conditions for maintenance and technical documentation regarding the maintenance of the subsystem
- any technical requirement that must be taken into account during production, maintenance or operation of the subsystem
- results of design calculations made, examinations carried out, etc.,
- test reports.

If the TSI requires further information for the technical documentation, this shall be included.

4. The notified body must:
  - 4.1. Examine the technical documentation,
  - 4.2. Verify that the specimen(s) of the subsystem or of assemblies or subassemblies of the subsystem, has (have) been manufactured in conformity with the technical documentation, and carry out or have carried out the type tests in accordance with the provisions of the TSI and the appropriate European specifications. Such manufacture shall be verified using an appropriate assessment module.
  - 4.3. Where a design review is requested in the TSI, perform an examination of the design methods, the design tools and the design results to evaluate their capability to fulfil the requirements for conformity for the subsystem at the completion of the design process
  - 4.4. Identify the elements which have been designed in accordance with the relevant provisions of the TSI and the European specifications as well as the elements which have been designed without applying the relevant provisions of those European specifications;
  - 4.5. Perform or have performed the appropriate examinations and necessary tests in accordance with points 4.2. and 4.3 to establish where the relevant European specifications have been chosen, these have actually been applied;

**▼B**

- 4.6. Perform or have performed the appropriate examinations and necessary tests in accordance with point 4.2. and 4.3. to establish whether the solutions adopted meet the requirements of the TSI when the appropriate European specifications have not been applied.
- 4.7. Agree with the applicant the location where the examinations and necessary tests will be carried out.
5. Where the type meets the provisions of the TSI, the notified body shall issue a type-examination certificate to the applicant. The certificate shall contain the name and address of the contracting entity and the manufacturer(s) indicated in the technical documentation, conclusions of the examination, conditions for its validity and the necessary data for identification of the approved type. A list of the relevant parts of the technical documentation must be annexed to the certificate and a copy kept by the notified body.

If the contracting entity is denied a type-examination certificate, the notified body must provide detailed reasons for such denial.

Provision must be made for an appeals procedure.

6. Each notified body must communicate to the other notified bodies the relevant information concerning the type-examination certificates issued, withdrawn or refused
7. The other notified bodies may receive on request copies of the type-examination certificates issued and/or their additions. The annexes to the certificates must be kept at the disposal of the other notified bodies.
8. The contracting entity must keep with the technical documentation copies of type-examination certificates and any additions throughout the service life of the subsystem. It must be sent to any other member state which so requests.
9. The applicant must inform the notified body that holds the technical documentation concerning the type-examination certificate of all modifications which may affect the conformity with the requirements of the TSI or the prescribed conditions for use of the subsystem. The subsystem must receive additional approval in such cases. This additional approval may be given either in the form of an addition to the original type-examination certificate, or by issue of a new certificate after withdrawal of the old certificate.

#### MODULES FOR THE EC VERIFICATION OF SUBSYSTEMS

##### *Module SD: Production Quality Management System*

1. This module describes the EC verification procedure whereby a notified body checks and certifies, at the request of an contracting entity or its authorised representative established within the Community, that a Rolling Stock Freight wagon subsystem, for which already a type-examination certificate has been issued by a notified body,
  - complies with this TSI and any other applicable TSI, which demonstrate that the essential requirements <sup>(1)</sup> of Directive 01/16/EC <sup>(2)</sup> have been met
  - complies with the other regulations deriving from the Treaty,
 and may be placed in service.
2. The notified body carries out the procedure, under the condition, that:
  - the type examination certificate issued prior to the assessment remains valid for the subsystem subject to the application,
  - the contracting entity <sup>(3)</sup> and the main contractors involved are satisfying the obligations of point 3.

<sup>(1)</sup> The essential requirements are reflected in the technical parameters, interfaces and performance requirements, which are set out in Chapter 4 of the TSI.

<sup>(2)</sup> This module could be used in the future when the TSIs of the HS directive 96/48/EC are updated.

<sup>(3)</sup> In the module, 'the contracting entity' means 'the subsystem contracting entity, as defined in the directive. or his authorised representative established within the Community'.

**▼ B**

The ‘main contractors’ refers to companies, whose activities contribute to fulfil the essential requirements of the TSI. It concerns:

- the company responsible for the whole subsystem project (including in particular responsibility for subsystem integration),
- other companies only involved in a part of the subsystem project, (performing for example assembly or installation of the subsystem).

It does not refer to manufacturer sub contractors supplying components and interoperability constituents.

3. For the subsystem that is subject of the EC verification procedure, the contracting entity, or the main contractors when employed, shall operate an approved quality management system for manufacture and final product inspection and testing as specified in point 5 and which shall be subject to surveillance as specified in point 6.

When the contracting entity itself is responsible for the whole subsystem project (including in particular responsibility for subsystem integration), or the contracting entity is directly involved in the production (including assembly and installation), it has to operate an approved quality management system for those activities, which shall be subject to surveillance as specified in point 6.

If a main contractor is responsible for the whole subsystem project (including in particular responsibility for subsystem integration), it must operate in any case an approved quality management system for manufacture and final product inspection and testing, which shall be subject to surveillance as specified in point 6.

4. EC verification procedure
  - 4.1. The contracting entity must lodge an application for EC verification of the subsystem (through production quality management system), including co-ordination of the surveillance of the quality management systems, as under point 5.3 and 6.5. with a notified body of its choice. The contracting entity must inform the manufacturers involved of this choice and of the application.
  - 4.2. The application must enable the design, manufacture, assembly, installation, maintenance and operation of the subsystem to be understood, and shall enable conformity with the type as described in the type-examination certificate and the requirements of the TSI to be assessed.

The application must include:

- name and address of the contracting entity or its authorised representative
- the technical documentation regarding the approved type, including the type examination certificate, as issued after completion of the procedure defined in module SB,
  - and, if not included in this documentation,
    - a general description of the subsystem, its overall design and structure,
    - the technical specifications, including European specifications, that have been applied,
    - any necessary supporting evidence for the use of the above specifications, in particular where these European specifications, and the relevant clauses have not been applied in full. This supporting evidence must include the results of tests carried out by the appropriate laboratory of the manufacturer or on his behalf.
  - *The Rolling Stock register, including all information as specified in the TSI,*
  - the technical documentation regarding the manufacture and the assembly of the subsystem,
  - evidence of conformity to other regulations deriving from the treaty (including certificates) for the production phase
  - a list of the interoperability constituents to be incorporated into the subsystem,

**▼B**

- copies of the EC declarations of conformity or suitability for use with which the constituents must be provided, and all the necessary elements defined in annex VI of the directives,
- a list of manufacturers, involved in the subsystem's design, manufacturing, assembly and installation,
- the demonstration, that all stages, as mentioned under point 5,2, are covered by quality management systems of the contracting entity, if involved, and/or of the main contractors, and the evidence of their effectiveness,
- indication of the notified body, responsible for the approval and surveillance of these quality management systems.

- 4.3. The notified body shall first examine the application concerning the validity of the type examination and the type examination certificate.

If the notified body considers the type examination certificate no longer remains valid or is not appropriate and that a new type examination is necessary, it shall justify its decision.

5. Quality management system

- 5.1. The contracting entity, if involved, and the main contractors, when employed, must lodge an application for assessment of their quality management systems with a notified body of their choice.

The application must include:

- all relevant information for the subsystem envisaged,
- the quality management system documentation.

the technical documentation of the approved type and a copy of the type examination certificate, issued after the completion of the type examination procedure of module SB.

For those only involved in a part of the subsystem project, the information to be provided is only that for the relevant part.

- 5.2. For the contracting entity or the main contractor responsible for the whole subsystem project, the quality management systems shall ensure overall compliance of the subsystem with the type as described in the type-examination certificate and overall compliance of the subsystem with the requirements of the TSI. For other main contractor, their quality management system(s) has (have) to ensure compliance of their relevant contribution to the subsystem with the type as described in the type-examination certificate and with the requirements of the TSI.

All the elements, requirements and provisions adopted by the applicant(s) must be documented in a systematic and orderly manner in the form of written policies, procedures and instructions. This quality management system documentation shall ensure a common understanding of the quality policies and procedures such as quality programmes, plans, manuals and records. It must contain in particular an adequate description of the following items for all applicant(s):

- the quality objectives and the organisational structure,
- the corresponding manufacturing, quality control and quality management techniques, processes and systematic actions that will be used,
- the examinations, checks and tests that will be carried out before, during and after manufacture, assembly and installation, and the frequency with which they will be carried out,
- the quality records, such as inspection reports and test data, calibration data, qualification reports of the personnel concerned, etc.,

and also for the contracting entity or the main contractor responsible for the whole subsystem project:

- responsibilities and powers of the management with regard to overall subsystem quality, including in particular the subsystem integration management. The examinations,

tests and checking shall cover all of the following stages:



**▼ B**

- structure of subsystem, including, in particular, civil-engineering activities, constituent assembly, final adjustment,
  - final testing of the subsystem,
  - and, where specified in the TSI, the validation under full operation conditions.
- 5.3. The notified body chosen by the contracting entity must examine, if all stages of the subsystem as mentioned under point 5.2 are sufficiently and properly covered by the approval and surveillance of the quality management system(s) of the applicant(s) <sup>(1)</sup>.
- If the conformity of the subsystem with the type as described in the type-examination certificate and the compliance of the subsystem with the requirements of the TSI is based on more than one quality management system, the notified body shall examine in particular,
- if the relations and interfaces between the quality management systems are clearly documented
  - and if overall responsibilities and powers of the management for the compliance of the whole entire subsystem for the main contractors are sufficiently and properly defined.
- 5.4. The notified body referenced to in point 5.1. must assess the quality management system to determine whether it satisfies the requirements referenced in point 5.2. It presumes compliance with these requirements if the manufacturer implements a quality system for production, final product inspection and testing in respect of the Standard EN/ISO 9001 — 2000, which takes into consideration the specificity of the interoperability constituent for which it is implemented.
- When an applicant operates a certified quality management system, the notified body shall take this into account in the assessment.
- The audit shall be specific for the subsystem concerned, taking into consideration the specific contribution of the applicant to the subsystem. The auditing team must have at least one member experienced as an assessor in the subsystem technology concerned. The evaluation procedure shall include an assessment visit to the applicant's premises.
- The decision must be notified to the applicant. The notification must contain the conclusions of the examination and the reasoned assessment decision.
- 5.5. The contracting entity, if involved, and the main contractors shall undertake to fulfil the obligations arising out of the quality management system as approved and to uphold it so that it remains adequate and efficient.
- They must keep the notified body that has approved the quality management system, informed of any significant change that will affect the fulfilment of the TSI requirements by the subsystem.
- The notified body must evaluate the modifications proposed and decide whether the amended quality management system will still satisfy the requirements referenced in point 5.2 or whether a re-assessment is required.
- It must notify its decision to the applicant. The notification shall contain the conclusions of the examination and the reasoned assessment decision.
6. Surveillance of the quality management system(s) under the responsibility of the notified body
- 6.1. The purpose of surveillance is to make sure that the contracting entity, if involved, and the main contractors, duly fulfil the obligations arising out of the approved quality management system.
- 6.2. The contracting entity, if involved, and the main contractors must send to the notified body referenced in point 5.1 (or have sent) all the documents needed for that purpose including the implementation plans and technical records concerning the subsystem (as far as relevant for the specific contribution of the applicants to the subsystem), in particular:

<sup>(1)</sup> For the rolling stock TSI, the notified body may participate to the final in service test of locomotives or train set in the conditions specified in the relevant chapter of the TSI.

**▼B**

- the quality management system documentation, including the particular means implemented to ensure that:
    - for the contracting entity or main contractor, responsible for the whole subsystem project, overall responsibilities and powers of the management for the compliance of the whole entire subsystem are sufficiently and properly defined,
    - for each applicant, the quality management system is correctly managed for achieving integration at subsystem level,
  - the quality records as foreseen by the manufacturing part (including assembly and installation) of the quality management system, such as inspection reports and test data, calibration data, qualification reports of the personnel concerned, etc.
- 6.3. The notified body must periodically carry out audits to make sure that the contracting entity, if involved, and the main contractors, maintain and apply the quality management system and must provide an audit report to them. When those operate a certified quality management system, the notified body shall take this into account in the surveillance.
- The frequency of the audits shall be at least once a year, with at least one audit during the time period of performing relevant activities (manufacture, assembly or installation) of the subsystem being the subject of the EC verification procedure mentioned under point 8.
- 6.4. Additionally the notified body may pay unexpected visits to the relevant sites of the applicant(s). At the time of such visits, the notified body may conduct complete or partial audits and may carry out or cause to be carried out tests, in order to check the proper functioning of the quality management system where necessary. It must provide the applicant(s) with an inspection report and also, audit and/or test reports, as appropriate.
- 6.5. The notified body chosen by the contracting entity and responsible for the EC verification, if not carrying out the surveillance of all the quality management system(s) concerned, must co ordinate the surveillance activities of any other notified body responsible for that task, in order:
- to be ensured that correct management of interfaces between the different quality management systems relating to subsystem integration has been performed,
  - to collect, in liaison with the contracting entity, the necessary elements for the assessment to guarantee the consistency and the overall supervision of the different quality management systems.
- This co ordination includes the rights of the notified body:
- to receive all documentation (approval and surveillance), issued by the other notified bodies,
  - to witness the surveillance audits in point 6.3,
  - to initiate additional audits as in point 6.4 under its responsibility and together with the other notified bodies.
7. The notified body as referenced in point 5.1. must have entrance for inspection purposes, audit and surveillance to the locations of building sites, production workshops, locations of assembly and installations, storage areas and where appropriate, prefabrication and testing facilities and, more general, to all premises which it considers necessary in order to carry out its tasks, in accordance with the applicant's specific contribution to the subsystem project.
8. The contracting entity, if involved, and the main contractors must, for a period of 10 years after the last subsystem has been manufactured, keep at the disposal of the national authorities:
- the documentation referenced in the second indent of the second subparagraph of point 5.1,
  - the updating referenced in the second subparagraph of point 5.5,
  - the decisions and reports from the notified body, which are, referenced in points 5.4, 5.5 and 6.4.
9. Where the subsystem meets the requirements of the TSI, the notified body must then, based on the type examination and the approval and surveillance of the quality management system(s), draw up the certificate

**▼B**

of conformity intended for the contracting entity, who shall in turn draw up the EC declaration of verification intended for the supervisory authority in the Member State within which the subsystem is located and/or operates.

The EC declaration of verification and the accompanying documents must be dated and signed. The declaration must be written in the same language of the technical file and must contain at least the information included in Annex V of the Directive.

10. The notified body chosen by the contracting entity shall be responsible for compiling the technical file that has to accompany the EC declaration of verification. The technical file shall include at least the information indicated in the Art 18 (3) of the Directive, and in particular as follows:

- all necessary documents relating to the characteristics of the subsystem,
- a list of interoperability constituents incorporated into the subsystem,
- copies of the EC declarations of conformity and, where appropriate, of the EC declarations of suitability for use, which said constituents must be provided in accordance with Article 13 of the Directive, accompanied, where appropriate, by the corresponding documents (certificates, quality management system approvals and surveillance documents) issued by the notified bodies,
- all elements relating to the maintenance, the conditions and limits for use of the subsystem,
- all elements relating to the instructions concerning servicing, constant or routine monitoring, adjustment and maintenance,
- the type-examination certificate for the subsystem and the accompanying technical documentation as defined in the module SB,
- evidence of conformity with other regulations deriving from the treaty (including certificates)
- certificate of conformity of the notified body as mentioned under point 9, accompanied by corresponding calculation notes and countersigned by itself, stating that the project complies with the Directive and the TSI, and mentioning, where appropriate, reservations recorded during performance of the activities and not withdrawn. The certificate should also be accompanied by the inspection and audit reports drawn up in connection with the verification, as mentioned in points 6.3 and 6.4 and in particular:
- *the Rolling Stock register, including all information as specified in the TSI.*

11. Each notified body must communicate to the other notified bodies the relevant information concerning the quality management system approvals issued, withdrawn or refused.

The other notified bodies may receive on request copies of the quality management system approvals issued.

12. The records accompanying the certificate of conformity must be lodged with the contracting entity.

The contracting entity within the Community must keep a copy of the technical file throughout the service life of the subsystem; it must be sent to any other Member State which so requests.

#### MODULES FOR THE EC VERIFICATION OF SUBSYSTEMS

##### *Module SF: Product Verification*

1. This module describes the EC verification procedure whereby a notified body checks and certifies at the request of an contracting entity or its authorised representative established within the Community, that

**▼B**

a Rolling Stock Freight wagon subsystem, for which a type-examination certificate has already been issued by a notified body,

- complies with this TSI and any other applicable TSI, which demonstrate that the essential requirements <sup>(1)</sup> of Directive 01/16/EC <sup>(2)</sup> have been met
- complies with the other regulations deriving from the Treaty

and may be placed into service

2. The contracting entity <sup>(3)</sup> must lodge an application for EC verification (through product verification) of the subsystem with a notified body of his choice. The application shall include:
  - The name and address of the contracting entity or its authorised representative
  - the technical documentation.
3. Within that part of the procedure the contracting entity checks and attests that the subsystem concerned is in conformity with the type as described in the type examination certificate and satisfies the requirements of the TSI that apply to it.

The notified body shall carrying out the procedure under the condition that the type examination certificate issued prior to the assessment remains valid for the subsystem subject to the application.

4. The contracting entity must take all measures necessary in order that the manufacturing process (including assembly and integration of interoperability constituents by main contractors <sup>(4)</sup> when employed) ensures conformity of the subsystem with the type as described in the type-examination certificate and with the requirements of the TSI that apply to it.
5. The application must enable the design, manufacture, installation, maintenance and operation of the subsystem to be understood, and shall enable conformity with the type as described in the type-examination certificate and the requirements of the TSI to be assessed.

The application must include:

- the technical documentation regarding the approved type, including the type examination certificate, as issued after completion of the procedure defined in module SB,

and, if not included in this documentation,

- a general description of the subsystem, overall design and structure,
- the Rolling Stock register, including all information as specified in the TSI,
- conceptual design and manufacturing information, for example drawings, schemes of components, subassemblies, assemblies, circuits, etc.,
- the technical documentation regarding the manufacture and the assembly of the subsystem,
- the technical specifications, including European specification, that have been applied,
- any necessary supporting evidence for the use of the above specifications, in particular where these European specification and the relevant clauses have not been applied in full,

<sup>(1)</sup> The essential requirements are reflected in the technical parameters, interfaces and performance requirements, which are set out in Chapter 4 of the TSI.

<sup>(2)</sup> This module could be used in the future when the TSIs of the HS directive 96/48/EC are updated.

<sup>(3)</sup> In the module, 'the contracting entity' means 'the subsystem contracting entity, as defined in the directive. or his authorised representative established within the Community'.

<sup>(4)</sup> The 'main contractors' refers to companies, whose activities contribute to fulfil essential requirements of the TSI. It concerns the company that can be responsible for the whole subsystem project or other companies only involved in a part of the subsystem project, (performing for example assembly or installation of the subsystem).

**▼B**

- evidence of conformity to other regulations deriving from the treaty (including certificates) for the production phase
- a list of the Interoperability Constituents, to be incorporated into the subsystem,
- copies of the EC declarations of conformity or suitability for use with which said constituents must be provided and all the necessary elements defined in annex VI of the directives,
- a list of manufacturers involved in the subsystem's design, manufacture, assembly and installation,

If the TSI requires further information for the technical documentation, this shall be included.

6. The notified body shall first examine the application concerning the validity of the type examination and the type examination certificate.

If the notified body considers the type examination certificate no longer remains valid or is not appropriate and that a new type examination is necessary, it shall justify its decision.

The notified body must carry out the appropriate examinations and tests in order to check the conformity of the subsystem with the type, as described in the type examination certificate and with the requirements of the TSI. The notified body shall examine and testing of every subsystem manufactured as a serial product, as specified in point 4

7. Verification by examination and testing of every subsystem (as a serial product)

- 7.1. The notified body must carry out the tests, examinations and verifications, to ensure conformity of the subsystems, as serial products as provided for in the TSI. The examinations, tests and checking shall extend to the stages as provided for in the TSI.

- 7.2. Each subsystem (as serial product) must be individually examined, tested and verified <sup>(1)</sup> in order to verify its conformity with the type as described in the type-examination certificate and the requirements of the TSI that apply to it. When a test is not set out in the TSI, (or in an European Standard quoted in the TSI), the relevant European Specifications or equivalent tests are applicable.

8. The notified body may agree with the contracting entity (and the main contractors) the locations where the tests will be carried out and may agree that final testing of the subsystem and, whenever required in the TSI, tests or validation under full operating conditions, are carried out by the contracting entity under direct supervision and attendance of the notified body.

The notified body shall have entrance for testing and verification purposes to production workshops, locations of assembly and installations, and where appropriate, prefabrication and testing facilities in order to carry out its tasks as provided for in the TSI.

9. Where the subsystem meets the requirements of the TSI, the notified body must, draw up the certificate of conformity intended for the contracting entity, which in turn draws up the EC declaration of verification intended for the supervisory authority in the Member State where the subsystem is located and/or operates.

These NB activities shall be based on the type examination and the tests, verifications and checks carried out on all serial products as indicated in point 7 and required in the TSI and/or in the relevant European specification.

The EC declaration of verification and the accompanying documents must be dated and signed.

The declaration must be written in the same language of the technical file and must contain at least the information included in Annex V of the Directive.

<sup>(1)</sup> In particular, for the rolling stock TSI, the notified body will participate in the final in service testing of rolling stock or train set. This will be indicated in the relevant chapter of the TSI

**▼B**

10. The notified body shall be responsible for compiling the technical file that has to accompany the EC declaration of verification. The technical file shall include at least the information indicated in Art.18 (3) of the Directives, and in particular as follows:
- all necessary documents relating to the characteristics of the subsystem
  - the Rolling Stock register, including all information as specified in the TSI,
  - the list of interoperability constituents incorporated into the subsystem,
  - copies of the EC declarations of conformity and, where appropriate, of the EC declarations of suitability for use, which the constituents must be provided in accordance with Article 13 of the Directive, accompanied, where appropriate, by the corresponding documents (certificates, quality management system approvals and surveillance documents) issued by the notified bodies,
  - all elements relating to the maintenance, the conditions and limits for use of the subsystem,
  - all elements relating to the instructions concerning servicing, constant or routine monitoring, adjustment and maintenance,
  - the type-examination certificate for the subsystem and accompanying technical documentation, as defined in the module SB
  - certificate of conformity of the notified body as mentioned in point 9, accompanied by corresponding calculation notes and countersigned by itself, stating that the project complies with the directive and the TSI, and mentioning, where appropriate, reservations recorded during performance of activities and not withdrawn. The certificate should also be accompanied, if relevant, by the inspection and audit reports drawn up in connection with the verification.
11. The records accompanying the certificate of conformity must be lodged with the contracting entity.
- The contracting entity must keep a copy of the technical file throughout the service life of the subsystem; it must be sent to any other Member State which so requests.

## MODULES FOR THE EC VERIFICATION OF SUBSYSTEMS

*Module SH2: Full Quality Management System with Design Examination*

1. This module describes the EC verification procedure whereby a notified body checks and certifies, at the request of an contracting entity or its authorised representative established within the Community, that a Rolling Stock Freight wagon subsystem
- complies with this TSI and any other applicable TSI, which demonstrate that the essential requirements <sup>(1)</sup> of Directive 01/16/EC <sup>(2)</sup> have been met
  - complies with the other regulations deriving from the Treaty.
- and may be placed in service
2. The notified body shall carry out the procedure, including a design examination of the subsystem, under the condition, that the contracting entity <sup>(3)</sup> and the main contractors involved are satisfying the obligations of point. 3
- The ‘main contractors’ refers to companies, whose activities contribute to fulfil the essential requirements of the TSI. It concerns the company:
- responsible for the whole subsystem project (including in particular responsibility for subsystem integration),

<sup>(1)</sup> The essential requirements are reflected in the technical parameters, interfaces and performance requirements, which are set out in Chapter 4 of the TSI.

<sup>(2)</sup> This module could be used in the future when the TSIs of the HS directive 96/48/EC are updated.

<sup>(3)</sup> In the module, ‘the contracting entity’ means ‘the subsystem contracting entity, as defined in the directive. or his authorised representative established within the Community’.

**▼ B**

- other companies only involved only in a part of the subsystem project (performing for example design, assembly or installation of the subsystem).

It does not refer to manufacturer sub contractors supplying components and interoperability constituents.

3. For the subsystem that is subject of the EC verification procedure, the contracting entity or the main contractors, when employed, shall operate an approved quality management system for design, manufacture and final product inspection and testing as specified in point 5 and which shall be subject to surveillance as specified in point 6

The main contractor responsible for the whole subsystem project (including in particular responsibility for subsystem integration), must operate in any case an approved quality management system for design, manufacture and final product inspection and testing, which shall be subject to surveillance as specified in point 6.

In the case that the contracting entity itself is responsible for the whole subsystem project (including in particular responsibility for subsystem integration) or that the contracting entity is directly involved in the design and/or production (including assembly and installation), it shall operate an approved quality management system for those activities, which shall be subject to surveillance as specified in point 6.

Applicants which are only involved in assembly and installation, may operate only an approved quality management system for manufacture and final product inspection and testing

4. EC verification procedure

- 4.1. The contracting entity must lodge an application for EC verification of the subsystem (through full quality management system with design examination), including co ordination of surveillance of the quality management systems as in points 5.4. and 6.6., with a notified body of its choice. The contracting entity must inform the manufacturers involved of his choice and of the application.
- 4.2. The application must enable the design, manufacture, assembly, installation, maintenance and operation of the subsystem to be understood, and shall enable conformity with the requirements of the TSI to be assessed.

The application must include:

- name and address of the contracting entity or its authorised representative,
- the technical documentation including:
  - a general description of the subsystem, overall design and structure,
  - the technical design specifications, including European specifications, that have been applied,
  - any necessary supporting evidence for the use of the above specifications, in particular where the European specifications and the relevant clauses have not been applied in full.
- the test programme
- *the Rolling Stock register, including all information as specified in the TSI,*
- the technical documentation regarding the manufacture, the assembly of the subsystem,
- a list of the interoperability constituents to be incorporated into the subsystem,
- copies of the EC declarations of conformity or suitability for use with which the constituents must be provided and all the necessary elements defined in annex VI of the directives,
- evidence of conformity to other regulations deriving from the treaty (including certificates)
- a list of all manufacturers, involved in the subsystem's design, manufacturing, assembly and installation,

**▼ B**

- conditions for use of the subsystem (restrictions of running time or distance, wear limits etc),
  - conditions for maintenance and technical documentation regarding the maintenance of the subsystem
  - any technical requirement that must be taken into account during production, maintenance or operation of the subsystem
  - the explanation, of how all stages, as mentioned in point 5.2, are covered by quality management systems of the mains contractor(s) and/or of the contracting entity, if involved, and the evidence of their effectiveness,
  - indication of the notified body (ies) responsible for the approval and surveillance of these quality management systems.
- 4.3. The contracting entity shall present the results of examinations, checking and tests <sup>(1)</sup>, including type tests when required, carried out by its appropriate laboratory or on their behalf.
- 4.4. The notified body must examine the application concerning the design examination and assess the results of the tests. Where the design meets the provisions of the Directive and of the TSI that apply to it must issue a design examination report to the applicant. The report shall contain the conclusions of the design examination, conditions for its validity, the necessary data for identification of the design examined and, if relevant, a description of the subsystem's functioning.

If the contracting entity is denied a design examination report, the notified body must provide detailed reasons for such denial. Provision must be made for an appeals procedure.

5. Quality management system

- 5.1. The contracting entity, if involved, and the main contractors, when employed, must lodge an application for assessment of their quality management systems with a notified body of their choice.

The application must include:

- all relevant information for the subsystem envisaged,
- the quality management system documentation.

For those only involved in a part of the subsystem project, the information to be provided is only that for the relevant part.

- 5.2. For the contracting entity or the main contractor responsible for the whole subsystem project, the quality management system shall ensure overall compliance of the subsystem with the requirements of the TSI.

The quality management system(s), for other main contractor(s), has (have) to ensure compliance of their relevant contribution to the subsystem, with the requirements of the TSI. All the elements, requirements and provisions adopted by the applicants must be documented in a systematic and orderly manner in the form of written policies, procedures and instructions. This quality management system documentation shall ensure a common understanding of the quality policies and procedures such as quality programmes, plans, manuals and records.

The system must contain in particular an adequate description of the following items:

- for all applicants:
  - the quality objectives and the organisational structure,
  - the corresponding manufacturing, quality control and quality management techniques, processes and systematic actions that will be used,
  - the examinations, checking and tests that will be carried out before, during and after design, manufacture, assembly and installation and the frequency with which they will be carried out,

<sup>(1)</sup> The presentation of the results of the tests can be at the same time as the application or later.



**▼ B**

- the quality records, such as inspection reports and test data, calibration data, qualification reports of the personnel concerned, etc.,
- for the main contractors, as far as relevant for their contribution to the design of the subsystem:
  - the technical design specifications, including European specifications <sup>(1)</sup>, that will be applied and, where the European specifications will not be applied in full, the means that will be used to ensure that the requirements of the TSI that apply to the subsystem will be met,
  - the design control and design verification techniques, processes and systematic actions that will be used when designing the subsystem,
  - the means to monitor the achievement of the required design and subsystem quality and the effective operation of the quality management systems in all phases including production.
- and also for the contracting entity or the main contractor responsible for the whole subsystem project:
  - responsibilities and powers of the management with regard to overall subsystem quality, including in particular the subsystem integration management.

The examinations, tests and checking shall cover all of the following stages:

- overall design,
  - structure of the subsystem, including, in particular, civil-engineering activities, constituent assembly, final adjustment,
  - final testing of the subsystem,
  - and, where specified in the TSI, the validation under full operation conditions.
- 5.3. The notified body chosen by the contracting entity must examine, if all stages of the subsystem as mentioned in point 5.2 are sufficiently and properly covered by the approval and surveillance of the quality management system(s) of the applicant(s) <sup>(2)</sup>.

If the compliance of the subsystem with the requirements of the TSI is based on more than one quality management system, the notified body shall examine in particular,

- if the relations and interfaces between the quality management systems are clearly documented
- and if overall responsibilities and powers of the management for the compliance of the whole entire subsystem for the main contractor are sufficiently and properly defined.

- 5.4. The notified body referenced in point 5.1. must assess the quality management system to determine whether it satisfies the requirements of point 5.2. It presumes compliance with these requirements if the manufacturer implements a quality system for design, production, final product inspection and testing in respect of the Standard EN/ISO 9001 — 2000, which takes into consideration the specificity of the interoperability constituent for which it is implemented.

When an applicant operates a certified quality management system, the notified body shall take this into account in the assessment.

The audit shall be specific for the subsystem concerned, taking into consideration the specific contribution of the applicant to the subsystem. The auditing team must have at least one member experienced as an assessor in the subsystem technology concerned. The evaluation procedure shall include an assessment visit to the applicant's premises.

The decision must be notified to the applicant. The notification must contain the conclusions of the examination and the reasoned assessment decision.

<sup>(1)</sup> The definition of an European specification is indicated in the directives 96/48/EC and 01/16/EC and in the guidelines for application of HS TSIs

<sup>(2)</sup> For the rolling stock TSI, the notified body may participate to the final in service test of rolling stock or train set in the conditions specified in the relevant chapter of the TSI.

**▼B**

- 5.5. The contracting entity, if involved, and the main contractors shall undertake to fulfil the obligations arising out of the quality management system as approved and to uphold it so that it remains adequate and efficient.

They must keep the notified body that has approved their quality management system informed of any significant change that will affect the fulfilment of the requirements by the subsystem.

The notified body must evaluate any modifications proposed and decide whether the amended quality management system will still satisfy the requirements of point 5.2 or whether a re-assessment is required.

It shall notify its decision to the applicant. The notification shall contain the conclusions of the examination and the reasoned assessment decision.

6. Surveillance of the quality management system(s) under the responsibility of the notified body
- 6.1. The purpose of surveillance is to make sure that the contracting entity, if involved, and the main contractors duly fulfil the obligations arising out of the approved quality management system(s).
- 6.2. The contracting entity, if involved, and the main contractors must send the notified body referenced in point 5.1. (or have sent) all the documents needed for that purpose and in particular the implementation plans and technical records concerning the subsystem (as far as relevant for the specific contribution of the applicant to the subsystem), including:
- the quality management system documentation, including the particular means implemented to ensure that
    - for the contracting entity or the main contractor, responsible for the whole subsystem project, overall responsibilities and powers of the management for the compliance of the whole entire subsystem are sufficiently and properly defined,
    - for each applicant, the quality management system is correctly managed for achieving integration at subsystem level,
  - the quality records as foreseen by the design part of the quality management system, such as results of analyses, calculations, tests, etc.,
  - the quality records as foreseen by the manufacturing part (including assembly, installation and integration) of the quality management system, such as inspection reports and test data, calibration data, competency records of the personnel concerned, etc.
- 6.3. The notified body must periodically carry out audits to make sure that the contracting entity, if involved, and the main contractors maintain and apply the quality management system and shall provide an audit report to them. When they operate a certified quality management system, the notified body shall take this into account in the surveillance.
- The frequency of the audits shall be at least once a year, with at least one audit during the time period of performing the relevant activities (design, manufacture, assembly or installation) for the subsystem being the subject of the EC verification procedure mentioned in point 7.
- 6.4. Additionally the notified body may pay unexpected visits to the sites mentioned in point 5.2 of the applicant(s). At the time of such visits, the notified body may conduct complete or partial audits and may carry out or cause to be carried out tests in order to check the proper functioning of the quality management system where necessary. It must provide the applicant(s) with an inspection report and, audit and/or test reports as appropriate.
- 6.5. The notified body chosen by the contracting entity and responsible for the EC verification, if not carrying out the surveillance of all the quality management system(s) concerned as under point 5, must co ordinate the surveillance activities of any other notified bodies responsible for that task, in order:
- to be ensured that correct management of interfaces between the different quality management systems relating to subsystem integration has been performed.

**▼B**

- to collect, in liaison with the contracting entity, the necessary elements for the assessment to guarantee the consistency and the overall supervision of the different quality management systems.

This coordination includes the right of the notified body

- to receive all documentation (approval and surveillance), issued by the other notified body(s),
  - to witness the surveillance audits as in point 5.4.,
  - to initiate additional audits as in point 5.5. under its responsibility and together with the other notified body(s).
7. The notified body as referenced under point 5.1. must have entrance for inspection purposes, audit and surveillance to the locations of design, building sites, production workshops, locations of assembly and installation, storage areas and, where appropriate, prefabrication or testing facilities and, more general, to all premises which it considers necessary for its task, in accordance with the applicant's specific contribution to the subsystem project.
  8. The contracting entity, if involved, and the main contractors must, for a period of 10 years after the last subsystem has been manufactured, keep at the disposal of the national authorities:
    - the documentation referenced in the second indent of the second subparagraph of point 5.1,
    - the updating referenced in the second subparagraph of point 5.5,
    - the decisions and reports from the notified body which are referenced in the points 5.4, 5.5 and 6.4
  9. Where the subsystem meets the requirements of the TSI, the notified body must then, based on the design examination and the approval and surveillance of the quality management system (s), draw up the certificate of conformity intended for the contracting entity, who shall in turn draw up the EC declaration of verification intended for the supervisory authority in the Member State within which the subsystem is located and/or operates.
 

The EC declaration of verification and the accompanying documents must be dated and signed. The declaration must be written in the same language of the technical file and must contain at least the information included in Annex V of the Directive.
  10. The notified body chosen by the contracting entity shall be responsible for compiling the technical file that has to accompany the EC declaration of verification. The technical file shall include at least the information indicated in Art 18 (3) of The Directive, and in particular as follows:
    - all necessary documents relating to the characteristics of the subsystem
    - the list of interoperability constituents incorporated into the subsystem,
    - copies of the EC declarations of conformity and, where appropriate, of the EC declarations of suitability for use, which the constituents must be provided in accordance with Article 13 of the Directive, accompanied, where appropriate, by the corresponding documents (certificates, quality management system approvals and surveillance documents) issued by the notified,
    - evidence of conformity to other regulations deriving from the treaty (including certificates)
    - all elements relating to the maintenance, the conditions and limits for use of the subsystem,
    - all elements relating to the instructions concerning servicing, constant or routine monitoring, adjustment and maintenance
    - certificate of conformity of the notified body as mentioned under point 9, accompanied by corresponding calculation notes and countersigned by itself, stating that the project complies with the Directive and the TSI, and mentioning, where appropriate, reservations recorded during performance of the activities and not withdrawn. The certificate should also be accompanied, if relevant, by the inspection and audit reports drawn up in connection with the verification, as mentioned in points 6.4. and 6.5.;

**▼B**

— *the Rolling Stock register, including all information as specified in the TSI.*

11. Each notified body must communicate to the other notified bodies the relevant information concerning the quality management system approvals and the EC design examination reports, which it has issued, withdrawn or refused.

The other notified bodies may receive on request copies of:

- the quality management system approvals and additional approvals issued and
- the EC design examination reports and additions issued

12. The records accompanying the certificate of conformity must be lodged with the contracting entity

The contracting entity must keep a copy of the technical file throughout the service life of the subsystem; it must be sent to any other Member State which so requests.

**▼B**

## ANNEX BB

## STRUCTURES AND MECHANICAL PARTS

## Fixing of tail lamps

## BB.1 TAIL SIGNAL LAMP BRACKETS

*Fig. BB1*

## signal lamp bracket

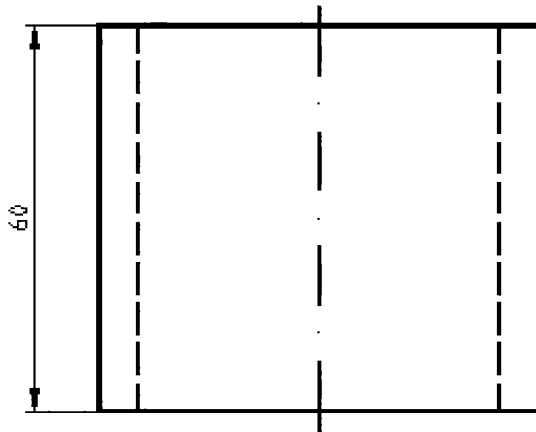

External plane of the vehicle wall

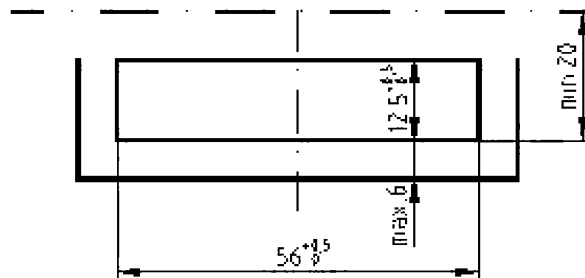

**▼ B**

BB.2 TAIL SIGNAL LAMPS: SPACE REQUIRED — ENVELOPE

*Fig. BB2*

**Space required envelope**

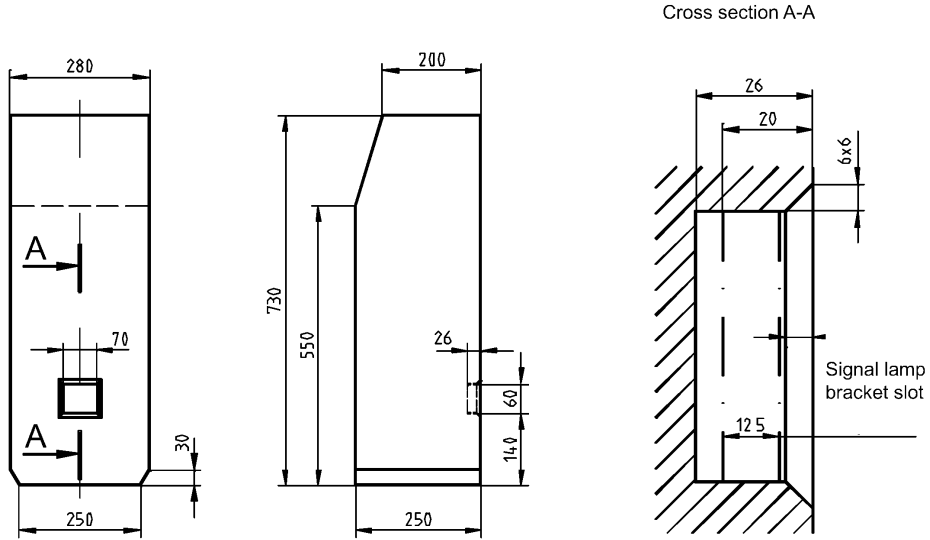



## ANNEX CC

**STRUCTURE AND MECHANICAL PARTS****Sources of fatigue loading**

## CC.1 PAYLOAD SPECTRUM

CC.1.1 **General**

Changes in payload are likely to cause significant fatigue load cycles. Where the payload changes significantly, the time spent at each load level shall be determined. Load/unload cycles should also be determined from the operator's specified duty and represented in a suitable manner for analysis purposes. Where applicable, account shall be taken of changes to the distribution of the payload and to the local pressure loads due to wheeled vehicles moving over the floor of the wagon.

CC.1.2 **Track induced loading**

Induced load cycles resulting from vertical, lateral and twist irregularities of the track shall be taken into account. These load cycles may be determined from:

- a) dynamic modelling;
- b) measured data;
- c) empirical data.

It is permissible to base fatigue design on load case data and assessment methods proven in the application where this exist. Tables 15 and 16 of EN12663 give empirical data, in the form of wagon body accelerations consistent with normal European operations suitable for an endurance limit approach to fatigue design when normal established data is available.

CC.1.3 **Traction and braking**

Load cycles due to traction and braking shall reflect the number of start-stops (including unscheduled ones) associated with the intended mode of operation.

CC.1.4 **Aerodynamic loading**

Significant aerodynamic load input may arise due to:

- a) trains passing at speed;
- b) tunnel operation;
- c) cross winds.

If such loading generates significant cyclic stresses in the structure it shall be included in the fatigue assessment.

CC.1.5 **Fatigue loads at interfaces**

The dynamic load used in design shall be in a range of +/- 30 % of the vertical static load.

If this assumption is not chosen, then the following method shall be followed:

The main fatigue loads at the body-bogie connection are due to:

- a) load/unload cycles;
- b) track input;
- c) traction and braking.

The interface shall be designed to carry the cyclic loads due these inputs.

Equipment attachments shall withstand the cyclic loads due to the motion of the wagon and any loads induced by the operation of the equipment. The accelerations may be determined as described above. For normal European operations,

**▼B**

empirically derived accelerations for items of equipment that follow the motion of the wagon structure are given in tables 17, 18 and 19 of EN12663 and can be used where no more appropriate data is available.

Cyclic loads in coupling components shall be taken into account if the experience of the operator or designer indicates they are significant.



**▼B**

*ANNEX DD*

**ASSESSMENT OF MAINTENANCE ARRANGEMENTS**

Open point, see § 6.2.2.3





Fig EE2

## Espace libre, Clearance, Freiraum

Espaces libres à respecter pour l'agent/le mécanicien de manœuvre au-dessus du  
marchepied gauche d'extrémité

Clearances to be left for the shunter/shunting locomotive driver above the left end  
step

Für den Rangierer/Lokrangierführer über dem linken Endtritt freizuhaltende Räume

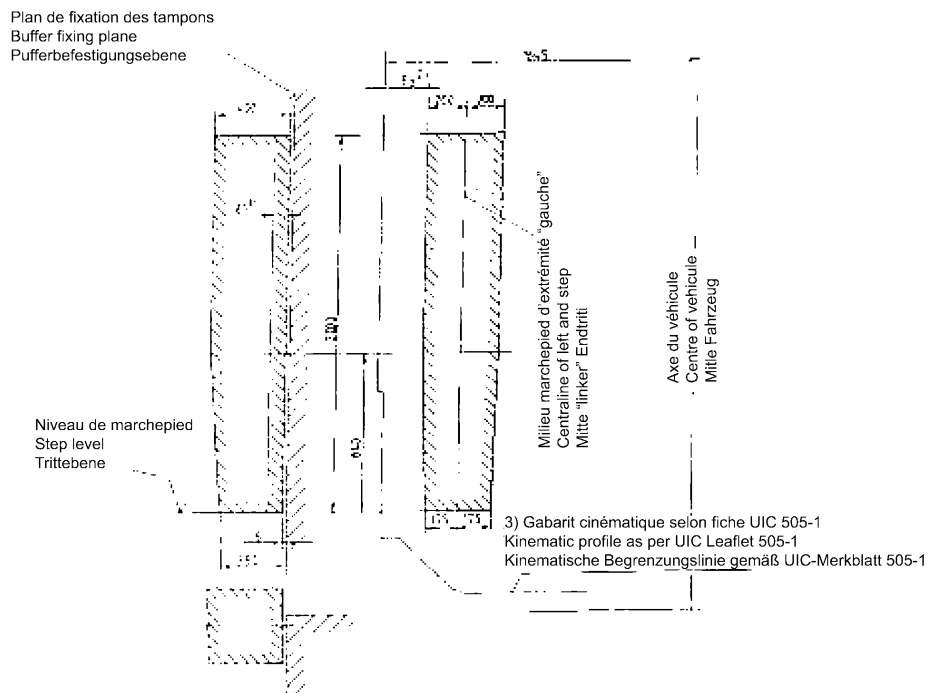

1) En cas de difficultés constructives, des éléments constitutifs tels que dispositifs de commande des parois coulissantes peuvent exceptionnellement engager cet espace. Ces éléments doivent toutefois être disposés parallèlement à la paroi de bout et ne présenter aucune arête saillante risquant de blesser.

In exceptional cases, components such as devices for operating sliding walls may encroach into this area, if difficulties inherent to the design of the wagon render this unavoidable. However, such components shall be mounted parallel to the end wall in such a way that they have no protruding edges that could cause injury.

In diesen Raum dürfen in Ausnahmefällen bei wagenbaulichen Schwierigkeiten Bauteile, z.B. Betätigungseinrichtungen für Schiebewände, hineinragen. Diese Bauteile müssen jedoch parallel zur Stirnwand konstruktiv so ausgelegt sein, daß sie keine hervorstehenden Kanten aufweisen, die Vernetzungen hervorrufen können.

2) Si la restriction extérieure l'exige, il convient d'adapter la cote Ea  
Dimension Ea shall be reduced if compliance with profile requirements renders this necessary  
Wenn es die äußern Einschränkung erfordert ist das Maß Ea entsprechend anzupassen.

3) Le gabarit selon la fiche UIC 503 s'applique pour le trafic avec la Grande-Bretagne  
The vehicle gauge according to UIC Leaflet 503 applies to traffic to and from Great Britain  
Für den Verkehr nach Großbritannien gilt die Begrenzungslinie nach UIC-Merkblatt 503

▼ B

Fig. EE3

## Hand rails for shunters

Mains courantes d'attelleurs  
Handrails for shunters  
Kupplergriffe

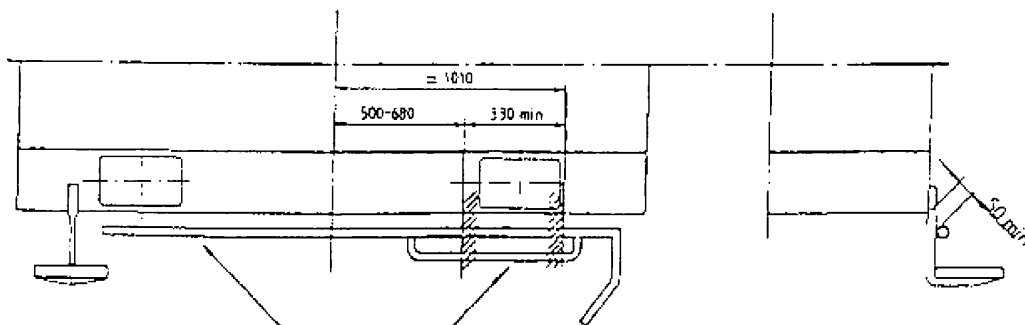
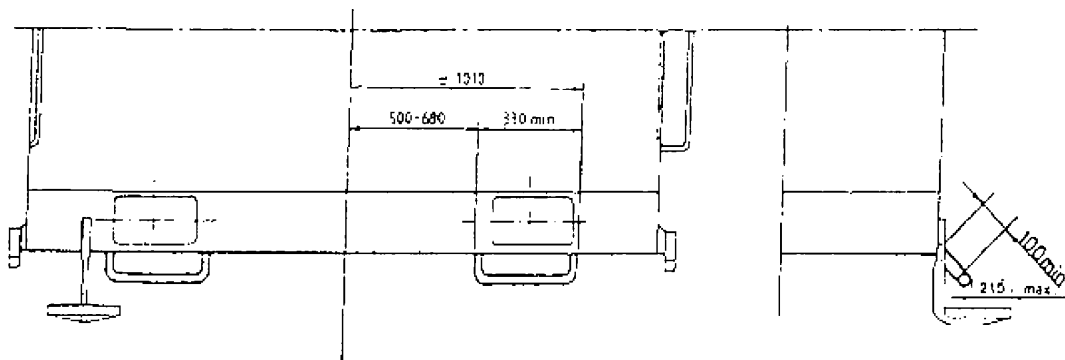

Zone utilisable par l'attelleur dans le cas d'un wagon avec AA

Area which may be used by the shunter in the case of a wagon fitted with the Automatic Coupler

Griffbereich für Wagen mit AK. (endvorbereitet)



## ANNEX FF

## BRAKING

## List of approved brake components

## FF1. WHEEL SLIDE PROTECTION DEVICES

## FF1.1. Wheel slide protection devices for new, existing, upgraded and renewed vehicles

Manufacturer	Type	Observations
FAIVELEY	AEF 82 C	Tested on disc brakes
OERLIKON	GSE 201	Tested on disc brakes
OERLIKON	GSE 202	Tested on disc brakes
FAIVELEY	AEF 83 P.1	Tested on disc brakes
FAIVELEY	AEF 83 P.2	Tested on shoe brakes
OERLIKON	OMG 202	Tested on disc brakes
PARIZZI	WUPAR 83	Tested on disc brakes
WABCO-WESTINGHOUSE	WGMC 19/1	Tested on disc brakes
FAIVELEY	AEF 91 P1 AEF 91 P2 (1)	Tested on disc brakes
MANNESMANN REXROTH PNEUMATIK GmbH	MRP-GMC 29	Tested on disc brakes
SAB WABCO KP GmbH	SWKP AS 20R	Tested on disc brakes
SAB WABCO KP GmbH	SWKP AS 20C	Confirm in January 1998: Type features identical to AS 20R
Knorr-Bremse	MGS 2	
DAKO	PE 94 MSV	

(1) Combined disc/shoe braked coaches

## FF1.2. Wheel slide protection devices for use on existing vehicles

The following list of WSP equipment is accepted for use on existing wagons, unless the brake system is upgraded or renewed. Other upgrades or renewals of the wagon will not require the change to the WSP system

Manufacturer	Type	Observations
<b>Mechanical Types</b> for speeds up to 160 km/h		
OERLIKON	inertia 4 GS1 & GSA	Tested on shoe brakes
KNORR	MW	(1)
KNORR	MWX	(1)
preferably only for trailing stock without its own electrical supply		



Manufacturer	Type	Observations
<b>Electronic Types</b>		
WESTINGHOUSE	D1	( <sup>1</sup> )
WESTINGHOUSE	WG	Tested on disc brakes
WESTINGHOUSE	WGK	Tested on shoe brakes
GIRLING	SP	Tested on disc brakes
OERLIKON	GSE 100	( <sup>1</sup> )
PARIZZI	289	Tested on shoe brakes
PARIZZI	447	Tested on disc brakes
KNORR	GR	( <sup>1</sup> )
KOVOLIS	DAKO	( <sup>1</sup> )
KRAUSS-MAFFEI	K Micro	( <sup>1</sup> )
OERLIKON	GSE 200	( <sup>1</sup> )
KNORR	MGS 1	Tested on disc brakes
WABCO-WESTINGHOUSE	WGMC 19	Tested on disc brakes

(<sup>1</sup>) Combined disc/shoe braked coaches

## FF 2. COMPRESSED-AIR BRAKES FOR 'FREIGHT TRAINS' AND 'PASSENGER TRAINS'

### FF 2.1. Distributor Valves for new vehicles, upgraded and renewed vehicles

Brake type	Abbreviated description	Abbreviated name	Compressed-air brake
			Freight train (G) Passenger train (P)
Knorr brake	KE 1d ( <sup>a</sup> ) ( <sup>b</sup> ) KE 2d ( <sup>b</sup> ), KERd ( <sup>c</sup> ) ( <sup>b</sup> )	KE	G/P brake
Oerlikon brake	ESG 121 ( <sup>d</sup> ) ( <sup>e</sup> )	0	G/P brake
Oerlikon brake	ESG 121-1 ( <sup>d</sup> ) ( <sup>e</sup> )	0	G/P brake
Knorr brake	KE 1 a/3,8 ( <sup>a</sup> ) ( <sup>b</sup> ) ( <sup>f</sup> )	KE	G/P brake
Oerlikon brake	ESH 100 ( <sup>g</sup> )	0	G/P brake
Oerlikon brake	ESH 200 ( <sup>h</sup> )	0	G/P brake
Knorr brake	KE 1ad ( <sup>a</sup> ) ( <sup>b</sup> ) KE 2ad ( <sup>b</sup> )	KE	G/P brake
SAB-WABCO	SW 4 ( <sup>i</sup> )	SW	G/P brake



Brake type	Abbreviated description	Abbreviated name	Compressed-air brake
			Freight train (G) Passenger train (P)
SAB-WABCO	SW 4C (j)	SW	G/P brake
SAB-WABCO	SW 4/3 (k)	SW	G/P brake
DAKO brake	CV1 nD (l)	OK	G/P brake
SAB-WABCO brake	C3WR (d) (e)	Ch	G/P brake
SAB-WABCO brake	C3W with AC3D (b)	Ch	G/P brake
SAB-WABCO brake	WU-C (d) (e)	WU	G/P brake
Oerlikon brake	Est3f 1 HBG 300 (d) (m) (n)	0	G/P brake
MZT HEPOS — brake	MH3f/HBG310/100 (d) MH3f/HBG310/200 (d) MH3f/HBG310/3xx (e) (d)	MH	G/P brake
Knorr-Bremse	KE1dv KE2dv KERdv (e)	KE	G/P brake

(e) Subsequent fitting of other relay valves not permitted.

(b) For use in new vehicles up to 1.1.2007.

(e) Brake assembly linked to a load-proportional braking system approved under section FF3.

(d) Separate pressure reducing valve necessary if backfed via main air supply pipe.

(e) Brake assembly made up of distributor, relay and supports.

(l) Additional maintenance measures on MAV to ensure that the maximum brake cylinder pressure of 3,8 bar is always achieved.

(e) No standard function up to 14 l attached brake cylinder or pre-control volumes.

(b) Standard function.

(l) SW 4 — controlled filling of auxiliary reservoir.

(j) SW 4C — controlled filling of control reservoir with protection against overload when brake is released.

(k) SW 4/3 — with the C3W cut-off valve (filling of control and auxiliary reservoirs almost identical times).

(l) Distributor choke should be adapted in stages to the vehicle's auxiliary reservoir volumes.

(m) Only to be used with added relay.

(n) Identity test failed on certain points, hence the limited period of re-use of these distributors on PKP and ÓBB only until 1.1.2010.

#### FF 2.2. Valves for vehicles existing before 2005 which are upgraded or renewed

Brake type	Abbreviated description	Abbreviated name	Compressed-air brake
			Freight train (G) Passenger train (P)
Knorr	KEs KE 2c AL	KE	G/P brake
Dako	CV CV1	DK	G/P brake
Westinghouse	U	WU	G/P brake
Charmilles brake	C 3 A	Ch	G/P brake
Oerlikon brake	Est 3f with HBG 300	0	G/P brake
Charmilles brake	C 3 W	Ch	G/P brake
Knorr brake	KE Od KE 1d KE 2d	KE	G/P brake
Westinghouse brake	C3 W2	WE	G/P brake



Brake type	Abbreviated description	Abbreviated name	Compressed-air brake
			Freight train (G) Passenger train (P)
Oerlikon brake	ESG 101	0	P brake
Oerlikon brake	ESG 121	0	G/P brake
Oerlikon brake	ESG 131	0	P brake
Oerlikon brake	ESG 141	0	G/P brake
Oerlikon brake	ESG 101-1	0	P brake
Oerlikon brake	ESG 121-1	0	G/P brake
Oerlikon brake	ESG 131-1	0	P brake
Oerlikon brake	ESG 141-1	0	G/P brake
Knorr brake	KE 1 a/3,8	KE	G/P brake
Knorr brake	KE Oa/3,8	KE	G/P brake
Oerlikon	ESH 100	O	G/P brake with non-universal action where the connected brake cylinder or pre-adjusted volumes are up to 14 l
Oerlikon	ESH 200	O	G/P brake with universal action
Knorr brake	KE 1 ad	KE	G/P brake
Knorr brake	KE 0 ad	KE	G/P brake
Knorr brake	KE 2 ad	KE	G/P brake
SAB-WABCO	SW 4 <sup>(a)</sup>	SW	G/P brake
SAB-WABCO	SW 4C <sup>(b)</sup>	SW	G/P brake
SAB-WABCO	SW 4/3 <sup>(c)</sup>	SW	G/P brake
DAKO brake	CV1 nD <sup>(d)</sup>	DK	G/P brake

<sup>(a)</sup> SW 4 — controlled filling of Auxiliary Reservoir.

<sup>(b)</sup> SW 4C — controlled filling of Auxiliary Reservoir with protection against over control reservoir overcharge when brake is released.

<sup>(c)</sup> SW 4/3 — with the C3W cut-off valve (filling of A and R takes place in practically the same time).

<sup>(d)</sup> Distributor choke should be adapted in stages to the vehicle's R reservoir volumes.

### FF 3. SELF-ADJUSTING LOAD-PROPORTIONAL BRAKING DEVICES APPROVED FOR INTERNATIONAL TRAFFIC

Manufacturer	Type	Abbreviated description
SAB	I — <b>Mechanical features</b> Load-proportional valve and automatic load-proportional distributor II — <b>Pneumatic features</b>	AC 3 D
WESTINGHOUSE	Load-proportional valve and differential brake cylinder	WDC 14 and WDC 16



## ▼ B

Manufacturer	Type	Abbreviated description
KNORR	Load-proportional valve and dual brake cylinder	RLV 12/10 DGB 10"/12"
OERLIKON	Load-proportional valve and dual brake cylinder	ALM-ALT
OERLIKON	Mechanical drive system and dual brake cylinder	ALS-ALT
WESTINGHOUSE	16" brake cylinder	WDR
OERLIKON	Relay valve for self-adjusting load-proportional brakes with single brake cylinder	ALM/ALR 150
KNORR	Relay valve for self-adjusting load-proportional brakes with single brake cylinder	RLV 11d
METALSKI ZAVOD-TITO	Relay valve for self-adjusting load-proportional brakes with single brake cylinder for high-speed intercity traffic.	AKR SS/10
METALSKI ZAVOD-TITO	Relay valve for self-adjusting load-proportional brakes with single brake cylinder for high-speed intercity traffic.	AKR S/01
KNORR	Relay valve for self-adjusting load-proportional brakes with single brake cylinder	RLV 11d
DAKO	Relay valve for self-adjusting load-proportional brakes DSS with load-proportional valve SL1 for high-speed intercity traffic.	DAKO-DSS
DAKO	Relay valve for self-adjusting load-proportional brakes DS with load-proportional valve SL1 for high-speed intercity traffic.	DAKO-DS
DAKO	Load-proportional valve	DAKO-DSS SL1 or SL2
DAKO	Load-proportional valve	DAKO-DS SL1 or SL2
SAB-WABCO	Load-proportional valve and dual brake cylinder	SWDR-2
SAB-WABCO	Relay valve for self-adjusting VCAV with distributor SW4, SW4-C or SW4/3 and load-proportional valve DP1 or F87	GF4 SS1 GF4 SS2 GF6 SS1 GF6 SS2
SAB WABCO	Relay valve for self-adjusting integrated VCAV with distributor SW4, SW4-C or SW4/3 and load-proportional valve DP1 or F87	GFSW4-D-AV GFSW4-S-AV

## FF 4. BRAKE PIPE EMPTYING ACCELERATORS ACCEPTED IN INTERNATIONAL SERVICES

Manufacturer	Type	Remarks
Dako-Kovalis	Dako-Z	Accepted for use in conjunction with the CV1-R type brake

▼ **B**

Manufacturer	Type	Remarks
Knorr-Bremse	EB3	Accepted for use in conjunction with the KEs type brake
	EB3-S	Fit for use with the NBŮ (~ SAFI)
	EB3-S/L	Fit for use with the NBŮ (~ SAFI)
Oerlikon-Buhrle	SB 3	Accepted for use in conjunction with the Est 3e type brake
	SBS 100	
Davies and Metcalfe	BPA 1	Fit for use with the NBŮ (~ SAFI)
MZT HEPOS	VBK 100	Fit for use with the NBŮ (~ SAFI)

## FF 5. QUICK-RELEASE VALVES ACCEPTED IN INTERNATIONAL SERVICES

Table 1

**Quick-release valves for modern brakes <sup>(a)</sup>**

Manufacturer	Type
<i>Installed in the distributor</i>	
OERLIKON	LV3:LV3F
OERLIKON	LV7
CHARM ILLES	C3P1
CHARM ILLES	C3P2
KNORR	ALV3a, ALV7,ALV9,ALV9a
WESTINGHOUSE (Italy)	SA1
WESTINGHOUSE (Italy)	SA1V
KNORR	AL V11
WESTINGHOUSE (Great Britain)	A1 and A2
<i>Applicable to existing distributors, when their circuits provide for the emptying of the control reservoir only</i>	
OERLIKON	LV3
OERLIKON	LV4F
WESTINGHOUSE (France)	W 104, W 204
WESTINGHOUSE (Italy)	SA1
WESTINGHOUSE (Italy)	SA1V

<sup>(a)</sup> Modern brakes are understood as being those approved for international services after 1.1.1948



Table 2

## Quick-release valves for old-type brakes

Manufacturer	Type
KNORR	AL V 4 <sup>(a)</sup>
OERLIKON	LV3
OERLIKON	LV4F
WESTINGHOUSE (France)	W 104, W 204
WESTINGHOUSE (Italy)	SA/CG, SA/RA
WESTINGHOUSE (Italy)	SA1
KNORR	L2 <sup>(b)</sup>
WESTINGHOUSE (Italy)	SARAV
HARDY	L3 <sup>(b)</sup>

<sup>(a)</sup> The KNORR ALV4 quick-release valve is applicable to the modern KNORR KE distributor since the latter's release valve only empties the control reservoir (the auxiliary reservoir is emptied by another means: isolating cock).

<sup>(b)</sup> Applicable only to the HIK distributor.

Table 3

Quick-release valves for modern <sup>(a)</sup> or old-type brakes

Manufacturer	Type
WESTINGHOUSE (France)	W3,W4
DAKO	0S1
KNORR	ALV4b
BDZ	BRV <sup>(b)</sup>

<sup>(a)</sup> Modern brakes are understood as being those approved for international services after 1.1.1948.

<sup>(b)</sup> Applicable only to the HIK distributor.

## FF 6. BRAKE PADS FOR VEHICLES EQUIPPED WITH DISC BRAKES, ACCEPTED FOR INTERNATIONAL TRAFFIC

Manufacturer/Product name	Type	Remarks	Railway request
1	2	4	5
Jurid	Jurid 869	up to 200 km/h	SNCF
Becorit	Becorit 918 <sup>(1)</sup>	up to 200 km/h	DB
Ferodo	ID 425 L <sup>(2)</sup>	up to 200 km/h	FS
Bremskerl	5818 <sup>(2)</sup>	up to 200 km/h	FS
Bremskerl	6792 <sup>(1)</sup>	up to 200 km/h	DB
Jurid	877 <sup>(1)</sup>	up to 200 km/h	DB
Bremskerl	7240 <sup>(1)</sup>	up to 200 km/h	DB

▼ **B**

Manufacturer/Product name	Type	Remarks	Railway request
1	2	4	5
Frendo	2126 <sup>(2)</sup>	up to 200 km/h	FS
Faist Licence Textar	T 543 <sup>(2)</sup>	up to 200 km/h	FS
ICER	ICER 918 <sup>(2)</sup>	up to 200 km/h	RENFE
Flertex	Flertex 664 HD <sup>(3)</sup>	up to 200 km/h	SNCF
Rona (Hungary) Licence Becorit	Rona 918 <sup>(2)</sup>	up to 200 km/h	MAV
Textar	T 550 <sup>(2)</sup>	up to 200 km/h	DB
Frenoplast x.	FR20H.2 <sup>(2)</sup>	up to 200 km/h	PKP
Textar	T550 <sup>(2)</sup>	up to 200 km/h	DB
Becorit	V30 <sup>(2)</sup>	up to 200 km/h	DB
Bremskerl	Bremskerl 2000 <sup>(2)</sup>	up to 200 km/h	DB
Bremskerl	7 699	up to 200 km/h	FS
Italian Brakes	FS 5M1 <sup>(1)</sup>	up to 200 km/h	FS

<sup>(1)</sup> tested on cast-iron and cast-steel disc brakes

<sup>(2)</sup> tested on cast-iron disc brakes

<sup>(3)</sup> tested on cast-steel disc brakes

#### FF 7. AUTOMATIC 'EMPTY-LOADED' CONTROL MECHANISMS ACCEPTED IN INTERNATIONAL TRAFFIC

Manufacturer	Type
a) multi-purpose usage	
Westinghouse	WAD
SAB	VA 2
SAB	DP 2
KNORR	Du-111 WM
OERLIKON	ALM/ALR 140
b) use only on loaded or empty wagons	
Westinghouse	WAN
SAB	VTA

#### FF 8. TEST BENCHES ASSESSED UP TO JUNE 2004 AS CAPABLE OF CARRYING OUT ACCEPTANCE TESTS ON BRAKE PADS

Company	Location
DB	Minden
FS	Florence

**▼ B**

Company	Location
SNCF	Vitry MF1 Vitry MF3
CFR	Bucarest
CD	Prague
PKP	Poznan
ZSR	Zilina



ANNEX GG

SPECIFIC CASES  
Irish loading gauges

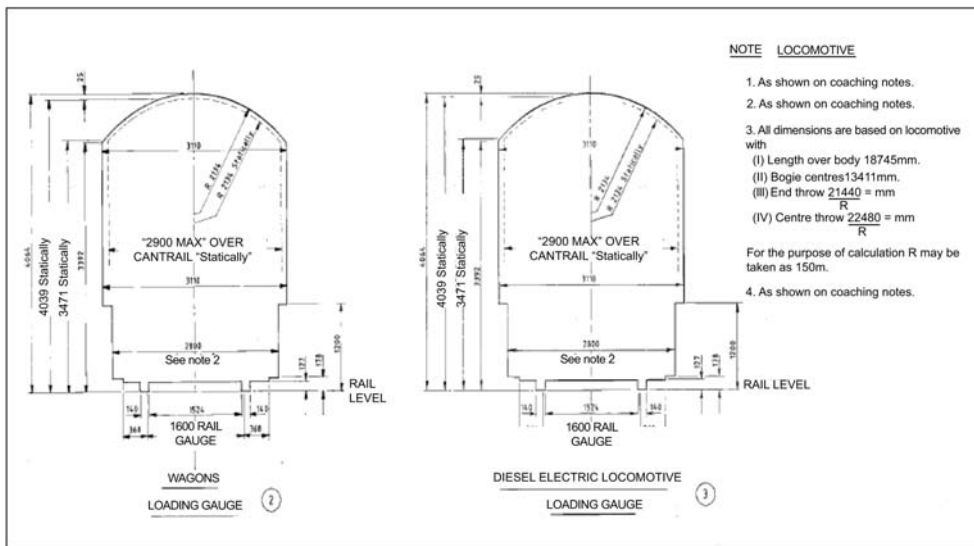
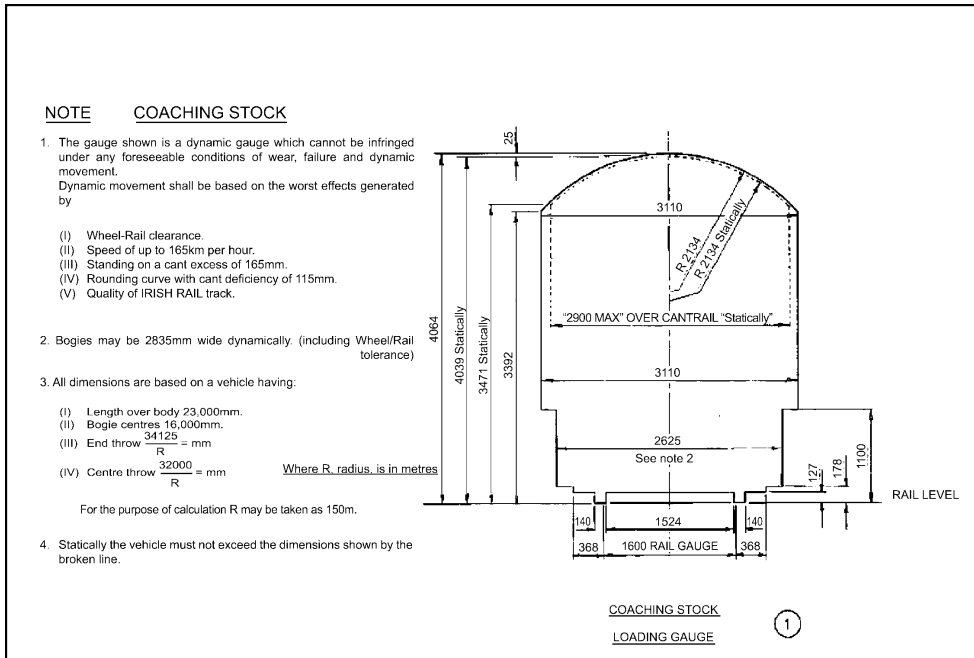

▼B

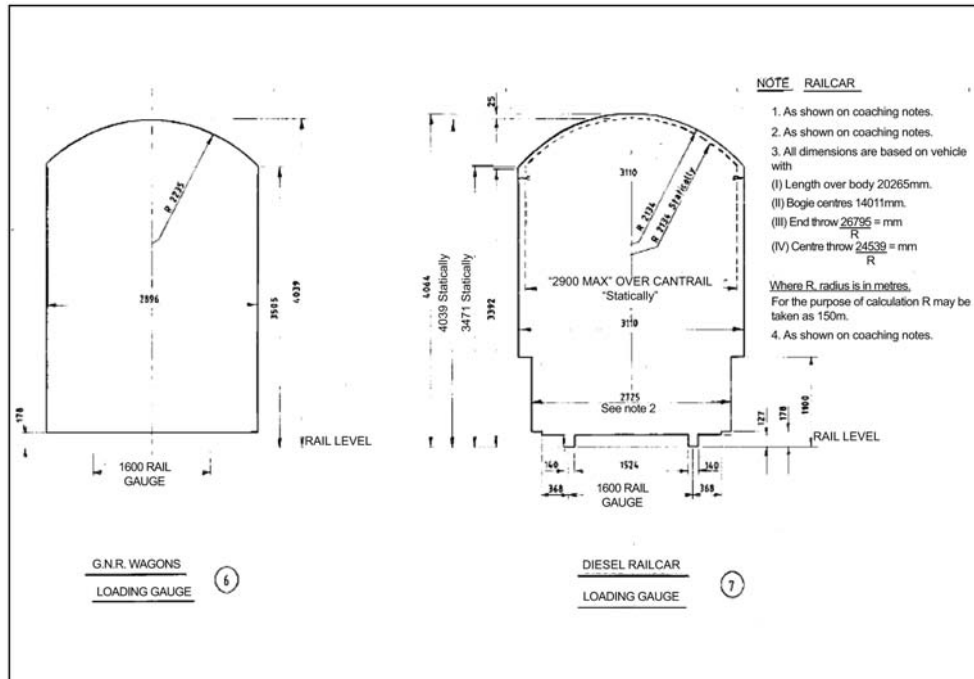
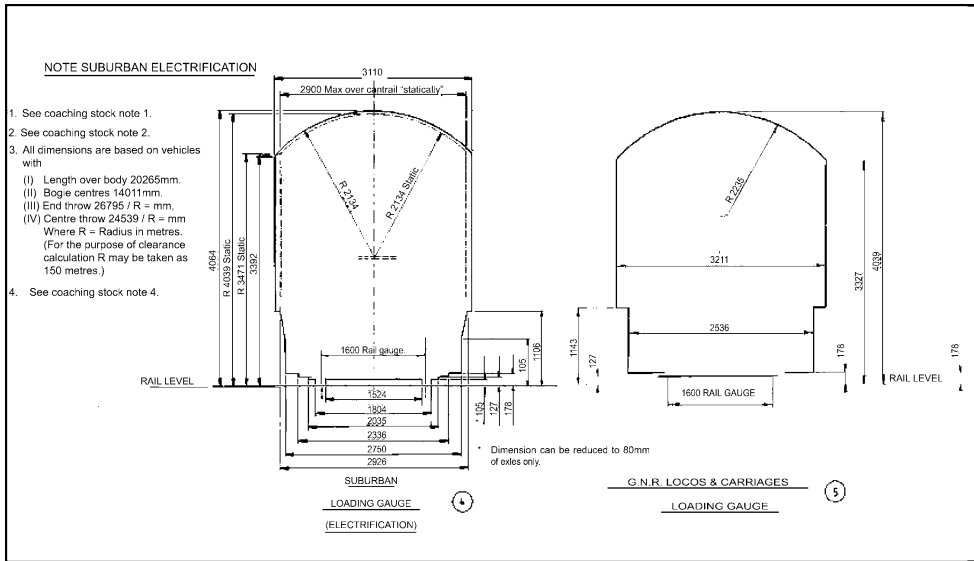







## ANNEX II

## VEHICLE TRACK INTERACTION AND GAUGING

**Assessment Procedure: Limits for modifications of freight wagons not requiring new approval**

Freight wagons, which have changes, as given within the limits of this Annex, in the technical parameters in comparison to the original design of the approved wagon shall not require a new conformity assessment

Distance between bogie centers (wagons with bogies)	$2a^* \geq 9\text{m}$	- 15 % to + $\infty$
	$2a^* < 9\text{m}$	- 5 % to + $\infty$
Vehicle wheel base (2axle wagons)	$2a^* \geq 8\text{m}$	- 15 % to + $\infty$
	$2a^* < 8\text{m}$	- 5 % to + $\infty$
Center of gravity height	Empty vehicle	- 100 % to + 20 %
	Loaded vehicle	- 100 % to + 50 %
Torsional stiffness $Ct^* \cdot (10^{10} \text{ kN/mm}^2/\text{rad})$	$Ct^* \leq 3$	- 66 % to + 200 %
	$Ct^* > 3$	- 50 % to + $\infty$
Vehicle tare	$\geq 16\text{t}$ (wagons with bogies)	- 15 % to + $\infty$
	$\geq 12\text{t}$ (2axle wagons)	
Modification of max. wheel set load		+ 1,5t
Moment of inertia of vehicle body (around z-axis — for 2axle wagons only)		- 100 % to + 10 %
vertical suspension primary or secondary	Stiffness	0 to + 25 %
	Transitional loads	- 5 % to 0
Rotational torque of bogie		- 20 % to + 20 %
Moment of inertia of whole bogie (around z-axis)		- 100 % to + 10 %
Nominal wheel diameter		- 10 % to + 15 %

The proof of the above mentioned as well as accompanying criteria such as strength, braking performance, kinematic gauge, etc is the manufacturer's or contracting entity's responsibility.

▼ **M1***ANNEX JJ*

## JJ.1. LIST OF OPEN POINTS

The table hereunder summarises the open points of this TSI and classifies each of them if related (column 'YES') or not (column 'NO') to technical compatibility between infrastructure and vehicles.

TSI reference	Title	YES	NO
4.2.3.3.2	Hot axle box detection	X	
4.2.6.2	Aerodynamic effects		X
4.2.6.3	Cross winds	X	
4.3.3	Traffic operation and management subsystem		X
6.1.2.2	Assessment of welding joints shall be made according to national rules.	X	
6.2.2.1	Assessment of welding joints shall be made according to national rules.	X	
6.2.2.3	Assessment of Maintenance	X	
6.2.3.4.2	Aerodynamic effects		X
6.2.3.4.3	Cross winds	X	
Annex E	Wheel treads remain an open point until EN is published	X	
Annex L	The specification of cast steel wheels is an open point. A new EN is requested.	X	
Annex P			
P.1.1	Distributor		X
P.1.2	Relay valve for variable load and automatic empty-load change-over		X
P.1.3	Wheel slide protection device		X
P.1.7	End Cocks		X
P.1.10	Brake blocks — Design assessment	X	
P.1.11	Accelerator valve		X
P.1.12	Automatic variable load sensing and empty/load changeover device		X
P.2.10	Brake blocks — Product assessment	X	

JJ.2. CLOSURE OF OPEN POINTS AND ADDITIONAL SPECIFICATIONS IN THE CASE OF WAGONS REFERRED TO IN SECTION 7.6.4

1. **Closure of open points**

For wagons identified in section 7.6 of this TSI, the open points identified in column 'YES' of Annex JJ-1 are closed in this section.

**▼ M1**1.1. *Hot Axle Box detection*

The open point identified in section 4.2.3.3.2 of this TSI is closed if the wagon complies with the specifications of the related ERA Technical Document.

1.2. *Cross winds*

The open point identified in sections 4.2.6.3 and 6.2.3.4.3 of this TSI is closed without any mandatory provision concerning wagon design. Some operational measures could apply.

1.3. *Assessment of welding joints*

The open point identified in sections 6.1.2.2 and 6.2.21 of this TSI is closed with the application of EN 15085-5 of October 2007.

1.4. *Assessment of maintenance*

The open point identified in Annex D of this TSI is closed as follows: Any maintenance file which:

- (a) was applied by a former registering RU member of RIV at the time of the revocation of RIV, or
- (b) was approved in accordance with a national or international rule

and which also complies with the requirements of this TSI is valid. The in-service performances are considered as satisfactory.

1.5. *Wheel treads*

The open point identified in Annex E of this TSI is closed as follows: the wheel tread defects will be considered in the maintenance frame.

1.6. *Cast wheels*

The open point identified in Annex L of this TSI is closed as follows: cast steel wheels are not authorised pending the publication of a European standard

1.7. *Design and Assessment of composite brake blocks*

The open point identified in Annexes P.1.10 and P.2.10 of this TSI is closed with the related technical document which is published on the ERA website.

**2. Additional specifications**

The following additional specifications are also required for wagons identified in section 7.6.4.

2.1. *Buffers and draw gears*

— In addition to the specifications of section 4.2.2.1.2.1 of this TSI, it is also required that buffers of wagons must be fitted with a guiding device for the plunger which prevents the latter from revolving freely around its longitudinal axis. The permitted tolerance for rotation is  $\pm 2^\circ$  for buffers when new.

— In addition to the specifications of section 4.2.2.1.2.2 of this TSI, it is also required that:

- (a) The intermediate draw gear of each set of permanently coupled wagons (or multiple wagons) must have a breaking strength in traction higher than that of the end draw gear.
- (b) The ERA Technical Document on 'additional specifications applicable to the draw gear' related to the following issues also applies (the prEN 15551 is expected to be published in April 2009):

▼ **M1**

- dynamic energy capacity,
  - attachments,
  - stroke and anti-rotation device,
  - mechanical resistance,
  - elastic characteristics,
  - markings,
  - buffer override calculation and buffer plate material,
  - dimension of the draw bar aperture,
- (c) For the mechanical resistance of assemblies, the draw gear (excluding elastic device), draw hooks, and screw coupling shall be designed for a life time of thirty years. Twenty years may be agreed at the customer's request.
- (d) The following table shows the range of forces and number of cycles to be applied for the dynamic type test.

**Conditions for the dynamic type tests**

Operational requirements			Range of forces to be applied		
Lifecycle (years)	Survival probability (%)	Safety factor ( $f_{sd}$ )	Designation	Step 1	Step 2
			1MN	$\Delta F1 = 200 \text{ kN}$	$\Delta F2 = 675 \text{ kN}$
			1,2 MN	$\Delta F1 = 240 \text{ kN}$	$\Delta F2 = 810 \text{ kN}$
			1,5 MN	$\Delta F1 = 300 \text{ kN}$	$\Delta F2 = 1015 \text{ kN}$
				N1 in cycles	N2 in cycles
20	97,5	1,7	All	$10^6$	$1,45 \times 10^3$
30	97,5	1,7	All	$1,5 \times 10^6$	$2,15 \times 10^3$

The dynamic type tests have to be carried out on three draw gears without elastic device. All three samples have to endure the tests without showing any damage. They shall not show any cracks, and the tensile force shall not drop below 1 000 kN.

## 2.2. *Strength of main vehicle structure*

In addition to the specifications of section 4.2.2.3.1 of this TSI, it is also required that:

- only tests and calculations for which numerical simulations have been validated are accepted;
- the maintenance file should take into account the following: the use of thermomechanical rolled steel requires special measures regarding heat (treatment).

## 2.3. *Jacking*

In addition to the specifications of section 4.2.2.3.2.4 of this TSI, the compliance of the jacking with the following diagram is also required:

## ▼ M1

Figure

## Relevage sur la voie / Rerailing

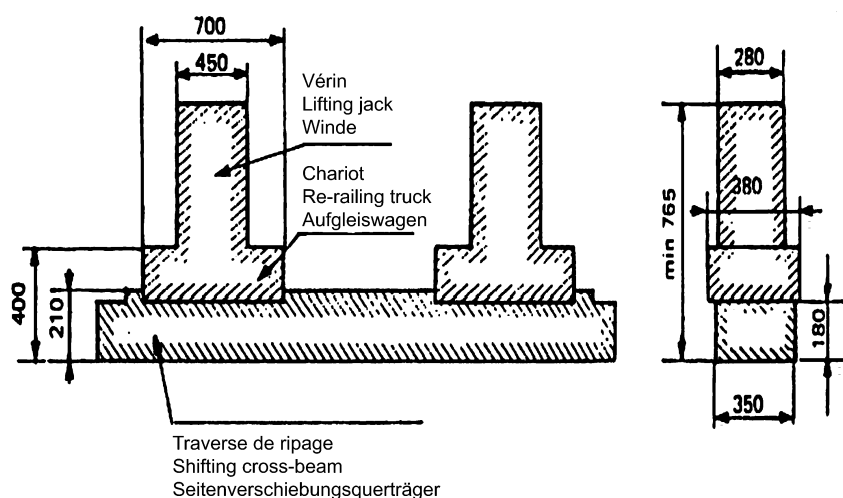

## 2.4. Axle

In addition to the specifications of section 5.4.2.4 and Annex M 1.4 of this TSI, for maximum permissible stresses the following standards apply: EN 13103 section 7, EN 13260 section 3.2.2 and EN 13261 section 3.2.3.

## 2.5. Dynamic behaviour of the vehicle

In addition to the specifications of section 4.2.3.4 of this TSI, it is required that for the particular cases of the bogies not listed in annex Y, EN 14363 or leaflet UIC 432 apply.

In addition to the specifications of section 4.2.3.4.2.2 of this TSI on safety against derailment when running on twisted tracks:

- One of the three methods given in EN 14363 applies;
- Freight wagons are exempted from these tests if they comply with the requirements of UIC leaflet 530-2.

## 2.6. Longitudinal compressive force

In addition to the specifications of sections 4.2.3.5 and Annex R of this TSI, compliance with section 3.2 of UIC leaflet 530-2 is also required, except for the requirements to communicate with and to receive the agreement from the UIC Study Group (SG) 2.

## 2.7. Braking

## 2.7.1. Energy storage

In addition to the specifications of section 4.2.4.1.2.4 of this TSI, it is required that the energy storage has to be designed in such a way that after a brake application (with the maximum brake cylinder pressure and maximum possible cylinder output stroke of the wagon at any load state) the pressure in the auxiliary reservoir must be at least 0,3 bar more than the brake cylinder pressure without the addition of any further energy.

## 2.8. Two-axle wagons

In addition to the specifications of section 4.2.3.4.2.4 of this TSI, the application of UIC leaflet 517 is mandatory for the calculation of the suspension of two-axle wagons.

**▼ M1**2.9. *Electric or electromagnetic interference*

Wagons fitted with a source of energy which may cause electrical interference must be examined against leaflets UIC 550-2 and 550-3. The electromagnetic signature of maximum train compositions must be validated.

2.10. *Special types of wagons*

For each of the following types of wagon, the related additional specifications apply:

- For wagons fitted with internal combustion engine: UIC leaflet 538;
- For multiple and articulated wagons: UIC leaflet 572;
- For wagons for the carriage of containers, swap bodies and horizontally loaded movable units: UIC leaflet 571-4;
- For heat insulated and refrigerated wagons: UIC leaflet 554-2;
- For semi trailers on bogies: UIC leaflet 597.

2.11. *Wagons coming to UK*

The wagons coming to the UK must also comply with UIC leaflet 503 requirements related to the specific UK conditions.



## ANNEX KK

## INFRASTRUCTURE AND ROLLING STOCK REGISTER

## Infrastructure register

## Requirements for the Infrastructure Register

Data Item	Interoperability Critical	Safety Critical
<b>Basic Data</b>		
Type of traffic (mixed, passenger, freight, ...)	√	
Type of line (HS, CR)	√	
<b>Technical Information</b>		
Performance levels: maximum line speed in function of maximum axle load and other items	√	√
Structure gauge	√	√
Track gauge	√	√
Maximum load per linear meter	√	√
Maximum track stressing — Dynamic load (maximum vertical load to be exerted by the wheels on the rail) — Transversal track forces — Longitudinal track forces	√	√
Relation wheel diameter and axle load	√	√
Minimum radius of curvature: horizontal	√	√
Minimum radius of curvature: vertical	√	√
Maximum cant	√	√
Maximum cant deficiency	√	√
Cant deficiency in switches and crossings	√	√
Compliance with Annex A1 of the CCS TSI		
Slip stream: RESERVED	√	√
Cross wind: RESERVED	√	√
Minimum distance between track centres	√	√
Track geometrical characteristics: — track geometrical quality (EN 13848-1) — track twist — Maximum value of free wheel passage in switches — Minimum value of fixed nose protection for common crossings — Maximum value of free wheel passage at crossing nose — Maximum value of free wheel passage at check/wing entry — Minimum flangeway width — Maximum permissible unguided length — Minimum flangeway depth — Maximum excess height of check rail	√	√

**▼ B**

Data Item	Interoperability Critical	Safety Critical
<b>Restrictions</b>		
Environmental limitations: Temperature range — T(n) (-40 °C —+35 °C), — T(s) (-25 °C —+45 °C),	√	√
Timescale restrictions: For T <sub>N</sub> lines Period of year when temperature expected to go below - 25 °C day.month  For T <sub>S</sub> lines Period of year when temperature expected to go above+35 °C day.month	√	√



## ANNEX LL

**HOT AXLE BOX DETECTION REFERENCE DOCUMENT**

*Note:* this Annex is also published as a Technical Document of the European Railway Agency and will be further maintained in accordance with Article 1a(4).

## 1. TERMS AND DEFINITIONS

For the purposes of this Annex, the following terms and definitions apply.

*Axle bearing:* a bearing or bearing assembly on a rail vehicle axle that transmits a proportion of the weight of the rail vehicle directly to the wheelset.

*Axle box:* the structure, including for example cartridge bearing adaptor, which houses, or is in contact with, the axle journal bearing and provides an interface with the bogie and/or suspension arrangement.

**Hot axle box detector (HABD):**

*Target zone:* a defined area on the underside of an axle box that is designed to have its temperature monitored by a HABD.

*Target area:* the plan view dimensions, that is in the XY plane, of the target zone.

*Prohibitive zone:* a zone in which heat sources such as exhausts, which might influence the behaviour of a HABD, are excluded or thermally shielded.

*Rolling stock coordinates:* rolling stock coordinates, figure 1, are based on the right hand rule Cartesian coordinate system, where the positive X-axis (longitudinal) is along the vehicle in the direction of travel, the Z-axis is vertically upwards and the origin is at the centre of the wheelset axle. The Y-axis is the lateral axis.

Figure 1

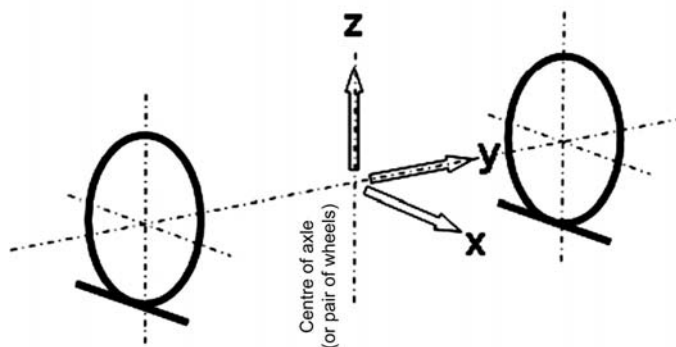
**Rolling Stock Coordinates**

*Wheelset:* a unit comprising: an axle, two wheels and their axle bearings, or a pair of independent wheels located at the same longitudinal position and their bearings.

*Heat source:* a part of the rolling stock that may have a temperature above the in-service running temperature of the underside of the axle box, such as a hot load or an exhaust pipe.

## 2. SYMBOLS AND ABBREVIATIONS

For the purposes of this Annex, the following symbols and abbreviated terms apply:

HABD Hot Axle box Detector

▼ **M1**

IM	Infrastructure Manager (as defined in the TSIs)
LPZ	Longitudinal length in mm of the prohibitive zone
LTA	Longitudinal length in mm of the target area
PZ	Prohibited zone
RST	Rolling stock (as defined in TSI)
RU	Railway Undertaking (as defined in TSI)
TA	Target area
TSI	Technical Specification for Interoperability
WPZ	Lateral width in mm of the prohibitive zone
WTA	Lateral width in mm of the target area
YPZ	Lateral position in mm of the centre of the prohibitive zone relative to the centre line of the vehicle
XTA	Longitudinal position of the centre of the target area relative to the centre line of the vehicle
YTA	Lateral position of the centre of the target area relative to the centre line of the vehicle

## 3. ROLLING STOCK REQUIREMENTS

This section contains the requirements for the rolling stock side of the HABD interface.

## 3.1. Target Zone

The target zone is an area on the underside surface of an axle box described by the intersection of the axle box with a virtual cuboid that has a horizontal cross sectional area given by the dimensions XTA and YTA using the rolling stock coordinates. The horizontal cross sectional area of the virtual cuboid is therefore congruent to the plan view area (that is in the XY plane) of the target zone, herein named the target area.

## 3.2. Target area

The target area is set in space relative to the axle dimensions, and defines an area in which a HABD can focus to monitor the temperature of an axle box. Figure 2 shows the position and minimum dimensions of the target area using rolling stock coordinates.

Figure 2

**Dimensions and position of the target area (TA) in the XY plane (viewed from below)**

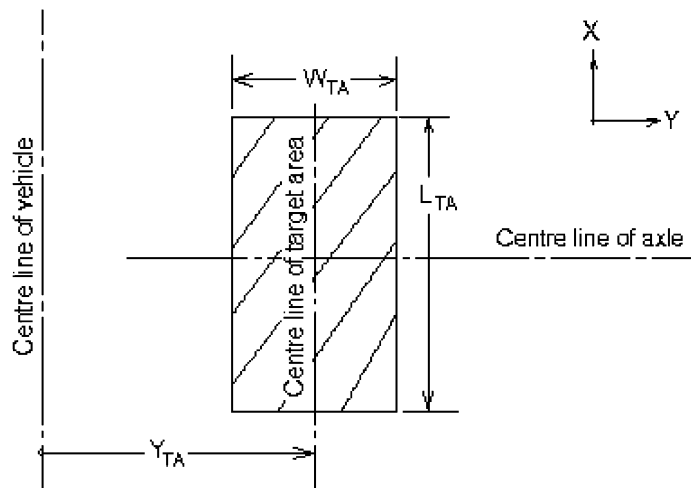

**▼ M1****3.3. Dimensions of the Target Area**

Taking into account mechanical tolerances the target area shall:

- have a lateral width, WTA, greater than or equal to 50 mm;
- have a longitudinal length, LTA, greater than or equal to 100 mm.

**3.4. Position of the Target Area in the XY plane**

In the XY plane the centre of the target area shall be positioned at a lateral distance, YTA, relative to the centre of the axle (or centre of a pair of wheels at the same position), where 1 065 mm is less than or equal to YTA and YTA is less than or equal to 1 095 mm. In the longitudinal axis the centre of the target area shall be congruent with the centre line of the axle.

**3.5. Visibility requirements for the Target Area**

Rolling stock shall be designed with no obstruction between the target zone and the HABD that would impede or prevent the HABD from focusing within the target zone and thereby prevent a measurement of its thermal radiation.

*Note:* The design of the rolling stock axle box should aim to achieve a homogeneous temperature distribution within the target zone.

**4. OTHER MECHANICAL DESIGN REQUIREMENTS**

To minimise the opportunity for a HABD to calculate a temperature from a heat source that is not an axle box, rolling stock shall be designed so that other heat sources, for example hot payload or exhaust, are not immediately adjacent to or directly above the target area position. To facilitate this no other heat source shall be located within the prohibitive zone defined in this document.

*Note 1:* If, due to the design of the rolling stock, it is possible/unavoidable for a heat source other than that of an axle box to be contained within the prohibitive zone, that heat source shall be thermally shielded to prevent erroneous temperature calculations by a HABD measuring its thermal radiation.

*Note 2:* The prohibitive zone shall be maintained for all rolling stock, including for example rolling stock with inboard bearings.

**4.1. Prohibitive Zone**

The prohibited zone is defined by a rectangular area, which includes the target area, and is extended vertically to form a virtual cuboid. The dimensions of the cuboid are LPZ and WPZ in the XY plane and HPZ in the vertical axes. Figure 3 shows a possible position of the target area in the prohibitive zone using rolling stock coordinates.

The dimensions of the prohibitive zone's cuboid, taking into account mechanical tolerances, shall be:

- lateral width, WPZ, greater than or equal to 100 mm;
- longitudinal length, LPZ, greater than or equal to 500 mm;
- vertical height, HPZ, starts at a point in the XY plane immediately above the HABD and ends at either the height of the target area, the height of a thermal shield or the height of the vehicle.

The position of the centre of the prohibitive zone in the X-Y plane shall be:

- in the lateral direction, YPZ = 1080 mm ± 5 mm measured relative to the centre of the axle (or centre of a pair of wheels at the same position);
- in the longitudinal direction it shall be congruent with the centre line of the axle ± 5 mm.

▼ M1

Figure 3

Dimensions of the prohibitive zone (PZ) in the XY plane (viewed from below) showing a possible position of a target area

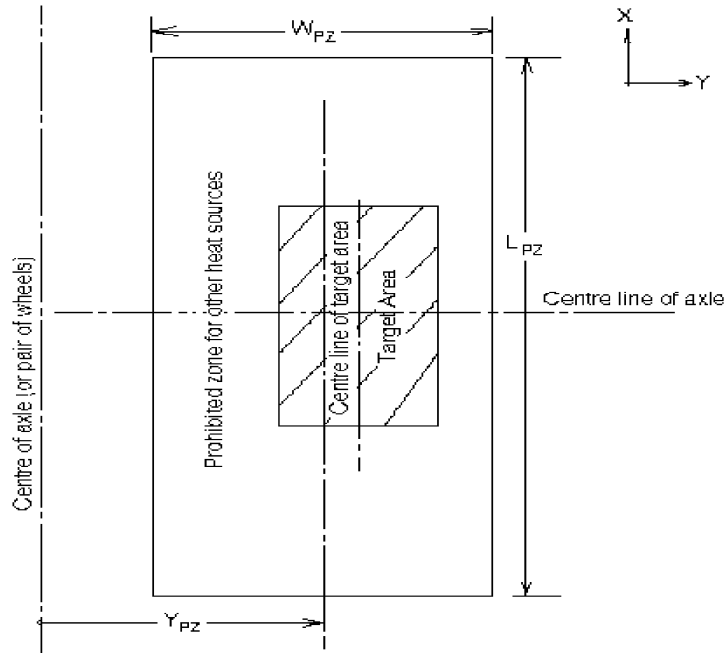

## 5. CROSS REFERENCE TABLE

For the purposes of traceability a cross-reference table relating this document with the original prEN 15437 is included

Document Section Ref.	prEN15437 Section Ref.
1	3.0
2	4.0
3	5
3.1	5.1
3.2	5.1.1
3.3	5.1.2
3.4	5.1.3
3.5	5.1.4
4	5.2
4.1	5.2.1



## ANNEX YY

**STRUCTURES AND MECHANICAL PARTS****Strength requirements for certain types of wagon components**

- YY.1. INTRODUCTION
- YY.2. STRENGTH OF WAGON BODY STRUCTURES
  - YY.2.1. Stresses due to the vertical load
  - YY.2.2. Combined stresses
  - YY.2.3. Strength of the wagon floor to support industrial trucks and road vehicles(1).
- YY.3. COVERED WAGONS WITH FIXED ROOF AND FIXED OR MOVING SIDE-WALLS AND COVERED WAGONS WITH SLIDING ROOFS
  - YY.3.1. Strength of fixed side and end-walls
  - YY.3.2. Strength of side doors
  - YY.3.3. Strength of sliding walls
  - YY.3.4. Forces resulting from the passing of trains
  - YY.3.5. Strength of lockable partitions of sliding-wall wagons
  - YY.3.6. Strength of roof
- YY.4. WAGONS WITH FULL OPENING ROOF (ROLLER ROOF AND HINGED ROOF)
  - YY.4.1. Wagons for the transport of heavy part-load goods
  - YY.4.2. Wagons for the transport of heavy bulk goods
- YY.5. HIGH-SIDED OPEN WAGONS
  - YY.5.1. Resistance of side-walls to transverse forces and of the edges of side and end rails to impacts
  - YY.5.2. Strength of the side doors
- YY.6. FLAT WAGONS AND COMPOSITE FLAT/HIGH-SIDED WAGONS
  - YY.6.1. Strength of the side and end flaps
  - YY.6.2. Strength of the fixed side-wall flaps
  - YY.6.3. Strength of the side stanchions
  - YY.6.4. Strength of end stanchions
- YY.7. GRAVITY DISCHARGE WAGONS
  - Strength of walls
- YY.8. WAGONS FOR THE CONVEYANCE OF ISO CONTAINERS AND/OR SWAP-BODIES
  - YY.8.1. Attachment of containers and swap-bodies
  - YY.8.2. Strength requirements for the container/swap-body retention devices
  - YY.8.3. Positioning of the container/swap-body retention devices
- YY.9. REQUIREMENTS FOR OTHER PAYLOAD SECURING EQUIPMENT
- YY.10. DEPOT TOW HOOKS

**▼ B**

## YY.1. INTRODUCTION

This appendix provides the requirements for the design of wagon components and load restraint systems applicable to types of wagon in general use. The requirements shall be adopted only where they are appropriate to the intended application.

## YY.2. STRENGTH OF WAGON BODY STRUCTURES

YY.2.1. **Stresses due to the vertical load**

For the vertical load case, the loads on the vehicle must be distributed:

- over a width of 2 m,
- in the case of open bogie wagons and open bogie flat wagons, over a width of 1,2 m,
- over the whole width of the floor,

according to which gives the more unfavourable stresses in the underframe.

The maximum deflection of the underframe under the applied load should not exceed 3 ‰ of the wheelbase or of the bogie pivot pitch from the initial position (including the effects of any counter-deflection).

YY.2.2. **Combined stresses**

For certain types of wagons, such as those with offset/depressed decks, it is particularly important to consider the combination of the stresses due to horizontal and vertical loading.

Tank wagons designed for the transport of pressurised products must be designed to withstand, without sustaining residual damage, both the load corresponding to the maximum permissible load capacity and that resulting from the maximum working pressure (as defined by the RID) for which the tank has to be designed.

YY.2.3. **Strength of the wagon floor to support industrial trucks and road vehicles <sup>(1)</sup>.**

The wagon floor should be capable of withstanding the following loads without suffering any residual deformation:

- By industrial trucks:
  - Simultaneous loading of each of the two front wheels of the truck with 30 kN;
  - Bearing surface of a wheel 220 cm<sup>2</sup> for a width of about 150 mm;
  - Average mean distance between the front wheels of the industrial truck 650 mm.
- By road vehicles (only with flat wagons and mixed open/flat wagons):
  - Loading with 65 kN per twin carrying wheel,
  - Bearing surface of a twin carrying wheel of 700 cm<sup>2</sup> for a wheel width of about 200 mm.

*Note:* Repetitive loads of this nature may need to be considered as fatigue load cases.

<sup>(1)</sup> Determination of the strength of freight wagon timber floors is the purpose of section 3A of ERRI Report B 12/DT 135 'Allgemein anwendbare Berechnungsmethoden für die Entwicklung neuer Güterwagenbauarten oder Güterwagendrehgestelle' (Generally applicable calculation methods for the development of goods new types of goods wagons or goods wagon bogies). This Technical Document contains details about the design of floors for new wagons. Tests need not be carried out if the floors correspond to the provisions of ERRI B 12/DT 135.

**▼B****YY.3. COVERED WAGONS WITH FIXED ROOF AND FIXED OR MOVING SIDE-WALLS AND COVERED WAGONS WITH SLIDING ROOFS****YY.3.1. Strength of fixed side and end-walls**

At a height of 1 m above the floor the walls should sustain the forces defined below (acting from the inside out). In the case of refrigerator vans, the characteristics of the material from which the inner skin and the insulation are made should be taken into account. There are four loading cases:

- a) transverse force applied to all side uprights;
- b) longitudinal force applied to all end posts;
- c) in the case of metal walls, transverse force acting on a point in the side-wall at the ventilation opening and along its centre-line;
- d) in the case of metal walls, longitudinal force acting along the centre-line of the end-wall.

Load case	Minimum Design Load kN	Permissible Permanent Deformation — mm
a	8	2
b	40	1
c	10	3
d	18	2

For load cases c) and d) above the loaded area shall be 100×100 mm

*Note:* Walls made of wooden panels should sustain the same loads as metal walls and the panels should be manufactured in a manner that ensures a consistent quality and performance.

**YY.3.2. Strength of side doors****Sliding doors (single and two-leafed)**

Transverse loading

The door(s) in closed position and locked, should sustain a horizontal normal force from the inside of the wagon outwards, representing the forces produced by a shift in the load as well as by pressure differences resulting from the high-speed passing of passenger trains in tunnels. This force is applied in the following conditions:

- a) at the centre of the door a force of 8kN applied over a 1×1 m area;
- b) at each connection/attachment point a force of 5 kN applied over 300×300 mm area.

No permanent deformation or loss of functionality should occur, either on the door itself (wall and framework) or on the locking, sliding or guiding components as a result of these loads.

**YY.3.3. Strength of sliding walls**

The sliding walls, closed and locked, should resist a horizontal cross force applied from the inside of the wagon outwards. This force represents the forces produced by a shift of the load as well as by pressure differences resulting from the high-speed passing of passenger trains in tunnels. The load cases are as follows:

- a) Sliding walls which are less than 2,5 m long should meet the same load cases as sliding doors;

**▼B**

- b) Sliding walls from 2,5 m to 5 m long should have a 20 kN load applied at mid-wall over a 1×1 m area.

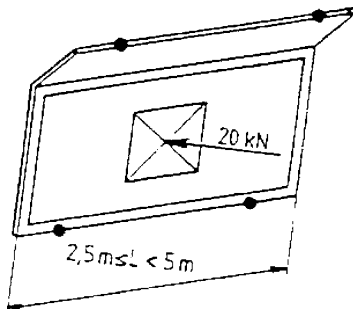

- c) Sliding walls over 5 m < 7 m long should have a 15 kN load applied in each case at a distance of 1/4 of the sliding wall length from the end of the sliding wall and at a height of 1 m over a 1×1 m area.

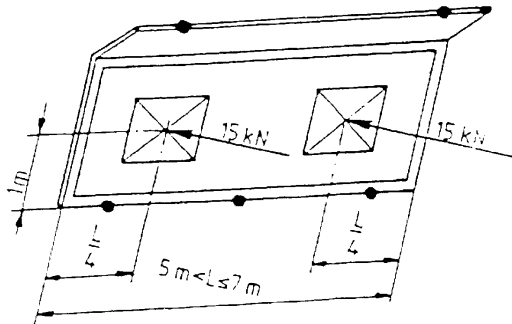

- d) Sliding walls over 7 m long should have a 20 kN load applied in each case at a distance of 1/4 of the length of the sliding wall from the end of the sliding wall and at a height of 1 m over a 1×1 m area.

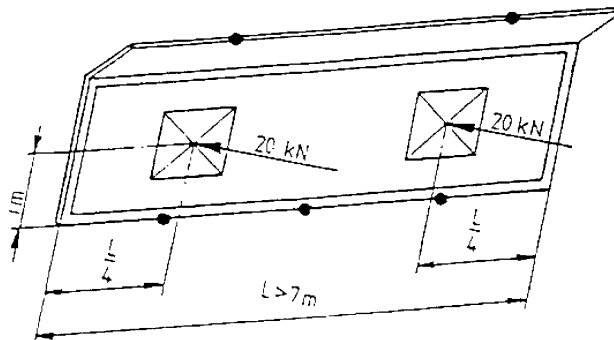

Plus the application of a 10 kN load on the lower flange of a sliding wall between two connection/attachment points immediately above floor level, over an area: 200 mm high by 300 mm wide.

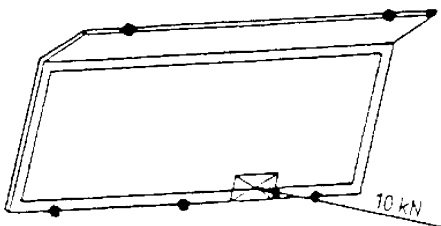



**▼B****YY.3.4. Forces resulting from the passing of trains**

Individual strength requirements for the outside connection/attachment points of the sliding wall (front surface over an area 200 mm high and 300 mm wide):

- a) with two-axled wagons and with bogie wagons with more than 2 sliding walls per side; force=11,5 kN
- b) with bogie wagons with 2 sliding walls per side; force=14 kN.

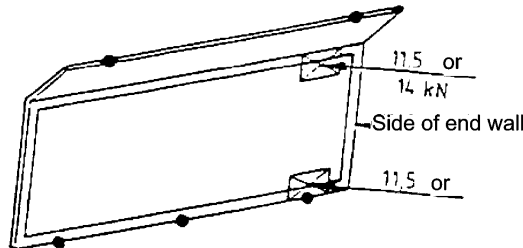

The point of application should be immediately above the floor and, in the roof area, as close as possible to the upper connection/attachment point. It is permissible for the upper load to be applied to the vertical section of the sliding wall.

No permanent visible deformation or deterioration of the elements for closing, rolling and guiding the wall should result from the application of the above loads. It must be possible to move the panels without difficulty. A permanent deformation, equal at most to half the distance between the inner face of an opened wall and the maximum projecting point of a closed wall, is permissible.

**YY.3.5. Strength of lockable partitions of sliding-wall wagons**

When the partition is locked a force which corresponds to a buffing impact of 5 t at a speed of 13 km/h and which simulates the stresses produced by a palletised load should be applied to a square surface area of 1x1 m, 600 mm and 1 100 mm above the top of the floor. The forces and deformation of the partition are to be measured. The deformation should not cause the partition to become detached or cause damage to the locking mechanism.

A force of 50 kN should be applied to the seat of the lower lock over an area measuring 100x100 mm. There must be no damage and no permanent deformation as a result of the load.

**YY.3.6. Strength of roof**

The roof must be able to withstand a force of 1 kN applied from outside inwards to a surface area of 200 cm<sup>2</sup> without any notable deformation.

In addition, sliding roofs must withstand a vertical force from the inside outwards of 4,5 kN per connection/attachment point applied over a 300x300 mm square area. No deterioration or permanent deformation of the elements for closing, rolling and guiding the sliding roofs should result from this load.

**YY.4. WAGONS WITH FULL OPENING ROOF (ROLLER ROOF AND HINGED ROOF)****YY.4.1. Wagons for the transport of heavy part-load goods****Strength of side-walls**

The side-walls should withstand a total force of 30 kN applied at the 4 door pillars, 1,5 m above the floor. Where applicable, the elastic deformation of the upper wall member should be lower than the derailing limit of the roof. After removal of the load, the roof should be in perfect working order.

**Strength of side-wall door**

The standard door requirements, 3.2, should be met.

**Strength of roof**

Where it is foreseeable that a person might walk on it, the roof should withstand the weight of a person walking over it. It should be able to take a force of 1 kN at the most unfavourable point on an area of 300x300 mm.

**▼B****YY.4.2. Wagons for the transport of heavy bulk goods**

Strength of side-walls

According to 4.1.

Strength of side-wall door

According to 3.2.

**Strength of roof**

According to 3.6.

**YY.5. HIGH-SIDED OPEN WAGONS****YY.5.1. Resistance of side-walls to transverse forces and of the edges of side and end rails to impacts**

The following load cases apply, acting outwards in the horizontal direction at a level of 1,5 m above the floor:

- a) a force of 100 kN applied at four centre posts of each side-wall, as indicated below;
- b) a force of 40 kN applied at the corner posts of wagons equipped with drop ends;
- c) 25 kN at the middle of the upper side-wall rails;
- d) 60 kN at the middle of the upper rail of the end swing doors, for wagons equipped with these.

*Note:* For the tests a) and b), the stipulated forces should be applied twice successively and only the deformations measured during the second load application should be taken into account.

The permanent deformation at the point where the force is applied should not exceed 1 mm. In addition, the elastic deformation should not result in any encroachment of the loading gauge.

**▼B****Local deformation tests**

Denting tests should be performed on the upper rails of the side-walls by applying a vertical force of 40 kN, as indicated below. The permanent deformation at the point where the force is applied should not exceed 2 mm.

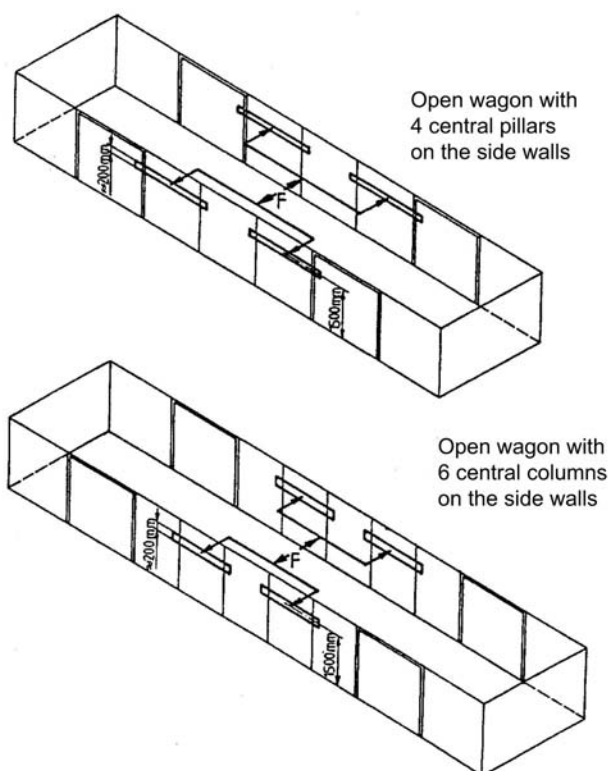
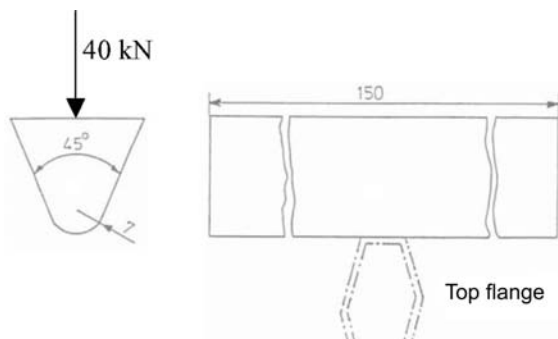
**YY.5.2. Strength of the side doors**

A horizontal force of 20 kN should be applied at a the height of the door locking bar or 1 m above the floor and on the centre-line of the opening. The permanent deformation must not exceed 1 mm on the door itself, and no deterioration or permanent deformation of the bridges or closing elements should result.

**YY.6. FLAT WAGONS AND COMPOSITE FLAT/HIGH-SIDED WAGONS****YY.6.1. Strength of the side and end flaps**

The requirement is to carry the load due to a lorry loaded to 65 kN per twin carrying wheel bearing on a total surface of 700 cm<sup>2</sup> {width of wheel about 200 mm) on the flaps lowered onto the buffers or onto supports rigidly fastened to the buffer beam in the case of the end flaps, and onto a high platform in the case of the side flaps.

No visible permanent deformation should result from the application of this load case.

**▼ B**

For the end flaps made of aluminum alloy, additional dynamic tests might be required.

In addition to the above, the load cases and static tests shown below are also to be applied.

**End Flap**

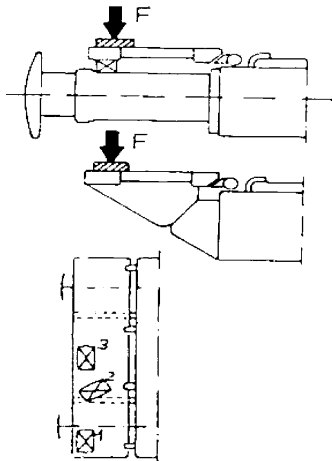

Flap dropped down onto the buffers

Flap dropped down onto supports rigidly fixed to the buffer beam

Application of a load of 65 kN at points 1,2 and then 3 over an area of 350 x 200 mm.

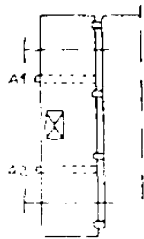

Flap dropped down onto 2 supports (At and A2) representing the two stanchions Application of a load of 75 kN at the centre of the flap over an area of 350 x 200 mm.

**Side Wall Flap**

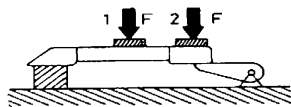

Flap dropped down into the horizontal position

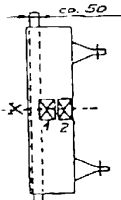

Hinges fixed by means of their pin

Lining inserted under the entire length of the flap

Application of loads at points 1 and then 2, of 65 kN, over an area of 350 x 200 mm.

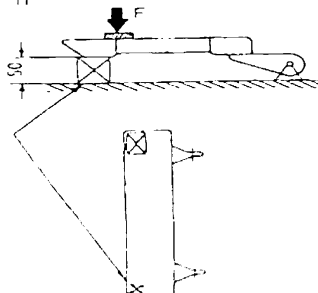

Flap dropped down into the horizontal position

Hinges fixed by means of their pin

-50 mm wedge (cube) arranged under one end

Application of 65 kN load over area of 350 x 200 mm onto the corner of the flap

**YY.6.2. Strength of the fixed side-wall flaps**

The fixed side-wall flaps should be subjected to a force of 30 kN, applied over an area measuring about 350x200 mm at the edge, directed horizontally from inside the wagon towards the outside and applied at the middle of the side.

**▼B****YY.6.3. Strength of the side stanchions**

Pivoting or removable side stanchions should take the following loads:

- An outward horizontal load of 35 kN acting at 500 mm from the centre of the bore-hole (swivelling Stanchion)
- An outward horizontal load of 35 kN acting at 500 mm from the upper fixation flange (removable stanchion).

**YY.6.4. Strength of end stanchions**

Each end stanchion should take an outward horizontal load of 80 kN acting at 350 mm above the top surface of the floor.

**YY.7. GRAVITY DISCHARGE WAGONS****YY.7.1. Strength of walls**

The walls should sustain the maximum permissible loads due to the goods they are intended to carry.

**YY.8. WAGONS FOR THE CONVEYANCE OF ISO CONTAINERS AND/OR SWAP-BODIES****YY.8.1. Attachment of containers and swap-bodies**

ISO containers and swap-bodies should be attached to rail vehicles using devices that engage with the load units' ISO corner castings or corner plates. Devices currently used for this purpose include spigots and twistlocks.

**YY.8.2. Strength requirements for the container/swap-body retention devices**

The container/swap-body retention devices, their associated mountings and their attachment to the vehicle should be capable of withstanding the following accelerations, applied to the maximum gross container/swap-body mass. The resulting force is to be applied at the base plane of the container/swap-body when restrained by the quantity of devices indicated in the table, these being assumed to share the load evenly. The fatigue loads are to be considered acting in phase for  $10^7$  cycles, or the number of cycles corresponding to the endurance limit in the fatigue design code (if this is less).

	Direction	Acceleration	Number of restraining locations
Proof Loads	Longitudinal	2g	Restrained at any 2 locations
	Transverse	1g	Restrained at any 2 locations
	Vertical Downward	2g	Restrained at 4 locations
	Vertical Upward	1g	Restrained at any 2 locations
Fatigue Loads	Longitudinal	$\pm 0,2g$	Restrained at 4 locations
	Transverse	$\pm 0,25g$	Restrained at 4 locations
	Vertical	$\pm 0,6g$	Restrained at 4 locations

The spigot installation should withstand, without undergoing deformation that would render it unfit for use, an upward vertical load of 150kN applied along the spigot centreline.

**▼B****YY.8.3. Positioning of the container/swap-body retention devices****Longitudinal positioning**

The retention devices shall be positioned so as to be compatible with the lengths of container/swap-body that the wagon has been specified to carry. The following table lists the longitudinal distances between retention devices for different lengths of Container and Swap-body:

Container/swap-body Dimension Code	Container/swap-body Length		Longitudinal distance between retention devices (mm)
	mm	ft in	
1	2 991	10'	2 787 ± 2
2	6 058	20'	5 853 ± 3
3	9 125	30'	8 918 ± 4
4	12 192	40'	11 985 ± 5
A	7 150		5 853 ± 3
B	7 315	24'	5 853 ± 3
C	7 420		5 853 ± 3
D	7 430	24'6"	5 853 ± 3
E	7 800		5 853 ± 3
F	8 100		5 853 ± 3
G	12 500	41"	11 985 ± 5
H	13 106	43"	11 985 ± 5
K	13 600		11 985 ± 5
L	13 716	45"	11 985 ± 5
M	14 630	48"	11 985 ± 5
N	14 935	49"	11 985 ± 5
P	16 154		11 985 ± 5

**Lateral Positioning****Fixed Retention Devices**

Fixed retention devices should be positioned laterally 2 259±2 mm apart on the wagon.

**▼ B****Fold-down spigots**

The functional dimensions (a1, a2 and C) for pairs of spigots after removal of play in the direction indicated by the arrows. These functional dimensions should be observed when running, irrespective of the type of construction of spigots (fixed or fold-down):

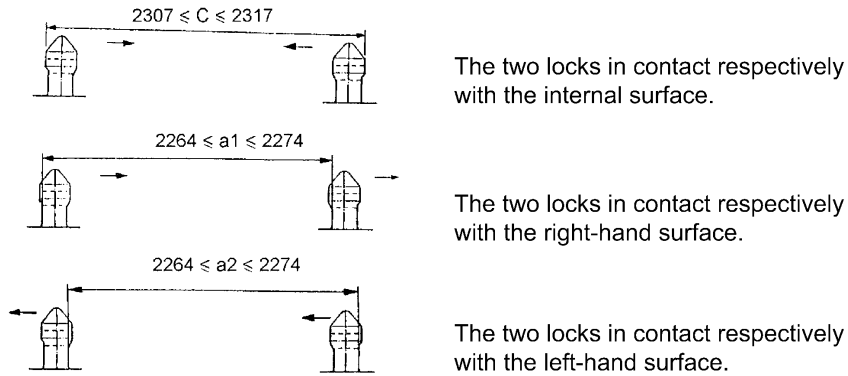
**Spigot Dimensions**

The permissible operational dimensions for the spigot are as follows:

Dimension at manufacture	Limit dimension when running
R3	Maximum R15
45°	Maximum 65°
4 <sup>+0,5/0</sup>	Minimum 3,5 mm
90° <sup>0/+1,5</sup>	Maximum 90° <sup>0/+2,0</sup> (see Note)

*Note:* When exerting a lateral force on the head of the spigot in the direction of the centre of the wagon (i.e. removal of all play), the angle should be measured between the body of the spigot and a steel rule placed at right angles to the sole-bars of the opposing spigots.





## ▼ B

Wagon Type and length over buffers	Alphacode	Type, number and position of load securing devices required	Load case (or dimensions) for each load securing device
Type 2 Two-axle covered wagons 10,58m	Gs	14 hinged ring or fixed fastening bar securing devices on each side wall with 6 in the upper row and 8 in the lower row.	Securing rings should be made from round-bar steel of at least 14mm diameter.
		If wagons are fitted with securing devices located in the wagon floor then 4 should be fitted, evenly distributed along each of the side walls (8 in total).	Should be able to withstand a tensile force of 85kN applied at an angle of 45° to the floor surface and 30° to the longitudinal centre-line of the wagon.
Types 3 Two-axle covered wagons 14,02m	Hbfs	18 hinged ring or fixed fastening bar securing devices on each side wall with 8 in the upper row (1,1m above the floor) and 10 in the lower row (0,35m above the floor).	Securing rings should be made from round-bar steel of at least 14mm diameter.
		If wagons are fitted with securing devices located in the wagon floor then 4 should be fitted, evenly distributed along each of the side walls (8 in total).	Should be able to withstand a tensile force of 85kN applied at an angle of 45° to the floor surface and 30° to the longitudinal centre-line of the wagon.
Two-axle Open high-sided wagons 10,0m	Es	To enable sheeting or securing of the load, securing devices should be fixed to the outside of the vehicle body, 8 on each side wall.	Should be made of round-bar steel at least 16mm in diameter
Two-axle Flat wagons 13,86m	Ks	Fastening bars or rings for sheeting purposes. 24 on the outside of the drop sides and 8 on the outside of the drop ends.	Should be made of round-bar steel of at least 16mm diameter.
		8 rings or fastening bars (4 per side wall) flush with the inside of the drop sides	Should be made of round-bar steel of at least 16mm diameter.
		12 fastening devices embedded in the floor, evenly distributed along each side wall.	Should be able to withstand a tensile force of 170kN applied at an angle of 45° to the floor surface and 30° to the longitudinal centre-line of the wagon.
Two-axle Open High-sided/flat composite wagons 13,86m	Os	12 sheeting rings affixed to the outside edge of the floor along each side wall and 4 along each end wall	Should be made of round-bar steel of at least 16mm diameter.
		4 securing rings should be affixed to the same edge along each side wall.	Should be made of round-bar steel of at least 16mm diameter.
Type 1 bogie Covered wagons 16,52m	Gas/Gass	16 hinged rings or fixed fastening bar i.e. 8 on each side wall. Devices should be fixed at 0,35m above floor level and must not protrude.	No strength requirement specified.

## ▼B

Wagon Type and length over buffers	Alphacode	Type, number and position of load securing devices required	Load case (or dimensions) for each load securing device
Type 2 bogie Covered wagons 21,7m	Gabs/ Gabss	14 securing devices situated on the side walls i.e. one at each end of the side walls, one at each door upright and one in the centre of each side wall. The devices should be situated approximately 1,5m above floor level. They must be flush with the wall.	Should be able to withstand a tensile force of 40kN exerted in a parallel direction to the longitudinal centreline of the wagon.
Type 1 High-sided open bogie wagons 14,04m	Eas/Eaos	13 securing rings on each side wall fixed on the outside of the body. 2 securing rings on each end wall fixed on the outside of the body.	Should be made of round-bar steel of at least 16mm diameter.
Type 2 High-sided open bogie wagons 15,74m	Eanos	6 securing rings on each side wall fixed on the inside of the body. 2 securing rings on each end wall fixed on the inside of the body. The devices should be spaced as regularly as possible at an approximate height of 0,2m above floor level and must be flush with the walls when not in use.	Should be able to withstand a tensile force of 40kN applied at an angle of 45° to the floor surface and 30° to the longitudinal centre-line of the wagon.
		14 securing rings on each side wall fixed on the outside of the body. 2 securing rings on each end wall fixed on the outside of the body.	Should be made of round-bar steel of at least 16mm diameter.
Type 1 Flat bogie wagons (without drop sides) 19,9m	Rs/Res	36 rings on the side solebars	Should be made of round-bar steel of at least 16mm diameter.
		8 rings on the outside of the drop ends	Should be made of round-bar steel of at least 16mm diameter.
		18 hooks on the side solebars.	Each hook should have a cross-section at least equivalent to a diameter of 40mm.
Type 1 Flat bogie Wagons (with drop sides) 19,9m	Rns/Rens	36 rings on the side solebars	Should be made of round-bar steel of at least 16mm diameter.
		8 rings on the outside of the drop ends	Should be made of round-bar steel of at least 16mm diameter.
		18 fastening bars flush with the inside of the drop sides/ends	Should be made of round-bar steel of at least 16mm diameter.
		18 securing devices in the floor evenly distributed along the length and must not protrude above floor level when not in use.	Should be able to withstand a tensile force of 170kN applied at an angle of 45° to the floor surface and 30° to the longitudinal centre-line of the wagon.

## ▼ B

Wagon Type and length over buffers	Alphacode	Type, number and position of load securing devices required	Load case (or dimensions) for each load securing device
Type 2 Flat bogie Wagons (without drop-sides) 14,04m	Rmms/ Rmmns	24 rings on the side solebars	Should be made of round-bar steel of at least 16mm diameter.
		8 rings on the outside of the drop ends	Should be made of round-bar steel of at least 16mm diameter.
		14 hooks on the side solebars.	Each hook should have a cross-section at least equivalent to a diameter of 40mm.
Type 2 Flat bogie Wagons (without drop sides) 19,9m	Remms/ Remmns	24 rings on the side solebars	Should be made of round-bar steel of at least 16mm diameter.
		8 rings on the outside of the drop ends	Should be made of round-bar steel of at least 16mm diameter.
		12 fastening bars flush with the inside of the drop sides/ends	Should be made of round-bar steel of at least 16mm diameter.
		12 securing devices in the floor evenly distributed along the length and must not protrude above floor level when not in use.	Should be able to withstand a tensile force of 170kN applied at an angle of 45° to the floor surface and 30° to the longitudinal centre-line of the wagon.
Bogie Wagon with opening roof 14,04m — 14,29m	Taems	The wagon floor may be equipped with 6 securing devices, evenly distributed on each side of the wagon (12 in total). If such devices are fitted, then they must be flush with the floor when not in use and must meet the strength requirements specified in the adjacent column.	Should be able to withstand a tensile force of 170kN applied at an angle of 45° to the floor surface and 30° to the longitudinal centre-line of the wagon.
Type 1 Covered bogie wagons with sliding walls 21,7m	Habiss	It is recommended that the wagon floor be fitted with 16 securing devices. If such devices are fitted then they should be spaced at intervals of 4 370mm/600mm/4 200mm/1 000mm/4 200mm/600mm/4 370mm in the longitudinal direction. In the lateral direction, the devices should be positioned 970mm from the longitudinal centre-line of the wagon. They must not protrude above the floor when not in use.	Should be able to withstand a tensile force of 85kN applied at an angle of 45° to the floor surface and 30° to the longitudinal centre-line of the wagon.
Type 2A Covered bogie wagons with sliding walls 24,13m	Habbins	The wagon should be provided with 16 securing devices in the floor. The fittings should be spaced at uniform intervals along each side wall. They must not protrude above the floor when not in use.	Should be able to withstand a tensile force of 85kN applied at an angle of 45° to the floor surface and 30° to the longitudinal centre-line of the wagon.
		Each end wall of the wagon should be provided with 4 securing fittings, arranged in sets of 2 near each corner	Should be able to withstand a tensile force of 30kN in all directions when this force is

## ▼ B

Wagon Type and length over buffers	Alphacode	Type, number and position of load securing devices required	Load case (or dimensions) for each load securing device
		upright inside the wagon at heights of about 0,75 and 1,5m above the floor.	exerted simultaneously on two fittings at the same height.
Two-axle covered wagons with sliding walls Types 1A and 2A 14,2m and 15,5m respectively	Hbins/ Hbbins	Wagon should be provided with 12 load securing fixings in the floor. They must be positioned at uniform intervals along each side. They must not protrude above the floor when not in use.	Should be able to withstand a tensile force of 85kN applied at an angle of 45° to the floor surface and 30° to the longitudinal centre-line of the wagon.
		Each end wall of the wagon should be provided with 4 securing fittings, arranged in sets of 2 near each corner upright inside the wagon at heights of about 0,75 and 1,5m above the floor. These fittings must not protrude from the wall when not in use.	Should be able to withstand a tensile force of 30kN in all directions when this force is exerted simultaneously on two fittings at the same height.
Bogie flat wagons fitted with a mechanical sheeting system, 19,9m and 20,09 respectively	Rils/Rilns	It is recommended that 10 retractable securing rings be fitted. The securing rings should be evenly distributed in the longitudinal direction and should be flush with the floor when not in use.	Should be able to withstand a tensile force of 170kN applied at an angle of 45° to the floor surface and an angle of 30° with the vertical plane of the wagon's longitudinal axis.
		It is recommended that 4 securing rings be fitted on the inner surfaces of the end walls.	No strength requirement specified
Flat wagons with 2 three-axle bogies 16,4m	Sammns	26 round steel rings should be fixed to the solebars	Should be made of round-bar of at least 16mm diameter
		12 securing rings should be fixed to the floor and they should be evenly distributed along each side of the wagon and should be flush with the floor when not in use.	Should be able to withstand a tensile force of 170kN applied at an angle of 45° to the floor surface and an angle of 30° with the vertical plane of the wagon's longitudinal axis.

## YY.10. DEPOT TOW HOOKS

Where fitted, tow hooks shall conform with the following requirements:

Wagon feature	Number of Hooks	Location of Hooks
One or two gangways or end platforms, and underframe width ≤ 2 500mm	One on each side	Free
General case	One on each side	In the middle of the wagon
Design making it impossible to fit one hook in the middle of the wagon	Two on each side	Near the corners

The hook and its fastening to the underframe shall be strong enough to allow a rake with a total mass of 240 t, to be towed with a single hook, with the pull exerted outward at an angle of 30 degrees in relation to the centreline of the track. To achieve this the hook shall be designed to carry a tractive force of 50 kN.

**▼B***Notes*

1. The tow hook shall be positioned such that there is no danger of damaging the steps, coupler control levers and brake control handles by the towing cable.
2. The tow hook shall be positioned so as to avoid any risk of a shunter's clothing (particularly trouser legs) becoming caught when climbing on or off a step.
3. To reduce the potential danger to staff at the side of the train no parts of tow hooks shall protrude by more than 250mm beyond the wagon underframe or body. Where parts of the hook protrude by between 150mm and 250mm beyond the wagon underframe or body, the hook and its support shall be painted yellow.



## ANNEX ZZ

**STRUCTURES AND MECHANICAL PARTS**  
**Permissible Stress Based on Elongation Criteria**

## ZZ.1. STRUCTURAL STEELS

For structural steels, the margin of safety represented by factor  $S_2$  in clause 3.4.3 of EN12663:2000 can be determined from the material elongation at failure. The table below gives a reduced value for  $S_2$  and acceptable criteria using this approach that have been proven in service.

	Material Property		Permissible stress
		Factor $S_2$	
Parent Metal	$R < 0,8 R_m$	$S_2 \geq 1,25$	$\sigma_c \leq R$
	$R > 0,8 R_m; A > 10 \%$	$S_2 < 1,25$	$\sigma_c \leq R$
	$R > 0,8 R_m; A < 10 \%$	$S_2 \geq 1,25$	$\sigma_c \leq \frac{R_m}{1,25}$
Weld Metal	$R < 0,8 R_m$	$S_2 \geq 1,25$	$\sigma_c \leq \frac{R}{1,1}$
	$R > 0,8 R_m; A > 10 \%$	$S_2 < 1,25$	$\sigma_c \leq \frac{R}{1,1}$
	$R > 0,8 R_m; A < 10 \%$	$S_2 \geq 1,25$	$\sigma_c \leq \frac{R_m}{1,375}$

*Note:* Notation is as in EN12663:2000; A = material elongation at failure.

## ZZ.2. OTHER STRUCTURAL MATERIALS

For other structural materials, the permissible stress shall be the lower value of the material yield (or proof stress) and the material ultimate stress divided by factor  $S_2$  as defined in clause 3.4.3 of EN12663.  $S_2$  shall be taken as 1,5 unless the criteria given in the Euronorm permit a lower value.