

Commission Decision of 9 November 2007 adopting a common specification of the national vehicle register provided for under Articles 14(4) and (5) of Directives 96/48/EC and 2001/16/EC (notified under document number C(2007) 5357) (2007/756/EC)

COMMISSION DECISION

of 9 November 2007

adopting a common specification of the national vehicle register provided for under Articles 14(4) and (5) of Directives 96/48/EC and 2001/16/EC

(notified under document number C(2007) 5357)

(2007/756/EC)

THE COMMISSION OF THE EUROPEAN COMMUNITIES,

Having regard to the Treaty establishing the European Community,

Having regard to Council Directive 96/48/EC of 23 July 1996 on the interoperability of the trans-European high-speed rail system⁽¹⁾, and in particular Articles 14(4) and (5) thereof,

Having regard to Directive 2001/16/EC of 19 March 2001 of the European Parliament and of the Council on the interoperability of the trans-European conventional rail system⁽²⁾, and in particular Articles 14(4) and (5) thereof,

Whereas:

- (1) Where Member States authorise the placing in service of rolling stock, they have to ensure that an identification code is assigned to each individual vehicle. This code should then be entered in a national vehicle register (hereafter NVR). This register must be accessible for consultation by authorised representatives from competent authorities and stakeholders. The different national registers should be consistent as regards data contents and data formatting. This requires their establishment on the basis of common operational and technical specifications.
- (2) The common specifications for the NVR should be adopted on the basis of the draft specification prepared by the European Railway Agency (hereafter the Agency). These draft specifications should include in particular the definition of: the content, the functional and technical architecture, the data format, the operating modes, including rules for data input and consultation.
- (3) This Decision has been prepared on the basis of the recommendation of the Agency No ERA/REC/INT/01-2006 dated 28 July 2006.
The NVR of a Member State should contain all vehicles authorised in that Member State. However freight wagons and passenger cars should be only registered in the NVR of the Member State where they are first placed in service.

Status: Point in time view as at 31/01/2020.

Changes to legislation: There are currently no known outstanding effects for the Commission Decision of 9 November 2007 adopting a common specification of the national vehicle register provided for under Articles 14(4) and (5) of Directives 96/48/EC and 2001/16/EC (notified under document number C(2007) 5357) (2007/756/EC). (See end of Document for details)

- (4) A standard form should be used for purposes of vehicles registration, confirmation of registration, alteration of registration item(s) and confirmation of the change(s).
- (5) Each Member State should establish a computer-based NVR. All NVRs should be linked to a central Virtual Vehicle Register (hereafter VVR) managed by the Agency in order to establish the register of documents on interoperability provided for Article 19 of Regulation (EC) No 881/2004⁽³⁾. The VVR should allow users to search all NVRs through a single portal and enable exchange of data between national NVRs. However, for technical reasons, the link to the VVR cannot be set up immediately. Therefore, Member States should only be required to connect their NVRs to the central VVR once the effective functioning of the VVR has been demonstrated. To this end, the Agency will carry out a pilot project.
- (6) According to item No 8 of the minutes of the meeting No 40 of the Regulatory Committee established under Article 21 of Directive 2001/16/EC, all existing vehicles should be registered in the NVR of the Member State where they were formerly registered. The transfer of data should take into account an adequate transition period and data availability.
- (7) In accordance with Article 14(4)(b) of Directive 96/48/EC and Article 14(4)(b) of Directive 2001/16/EC, the NVR should be kept and updated by a body independent of any railway undertaking. Member States should inform the Commission and the other Member States of the body which they have designated for this purpose, *inter alia*, in order to facilitate the exchange of information between these bodies.
- (8) Some Member States have an extensive 1 520 mm gauge network operating a fleet of wagons that is common to the Commonwealth of Independent States (CIS) countries. This has resulted in a common registration system that is an important element of the interoperability and safety of this 1 520 mm network. This specific situation should be recognized and specific rules established to avoid lack of consistency in the EU- and CIS-related obligations for the same vehicle.
- (9) The rules laid down in Annex P of the TSI on traffic operations and management are applicable with regard to the numbering system of vehicles for the purpose of registration in the NVR. The Agency will develop a guide for the harmonised application of these rules.
- (10) The measures provided for in this Decision are in accordance with the opinion of the Committee established under Article 21 of Directive 96/48/EC,

HAS ADOPTED THIS DECISION:

Article 1

The common specifications of the National Vehicle Register in accordance with Article 14(5) of Directive 96/48/EC and Article 14(5) of Directive 2001/16/EC, as set out in the Annex, are hereby adopted.

[^{F1}Article 1a

Appendix 6 of the Annex of this Decision shall apply from 1 January 2014.]

Status: Point in time view as at 31/01/2020.

Changes to legislation: There are currently no known outstanding effects for the Commission Decision of 9 November 2007 adopting a common specification of the national vehicle register provided for under Articles 14(4) and (5) of Directives 96/48/EC and 2001/16/EC (notified under document number C(2007) 5357) (2007/756/EC). (See end of Document for details)

Textual Amendments

- F1** Inserted by [Commission Decision of 14 November 2012 concerning the technical specification for interoperability relating to the 'operation and traffic management' subsystem of the rail system in the European Union and amending Decision 2007/756/EC \(notified under document C\(2012\) 8075\) \(Text with EEA relevance\) \(2012/757/EU\)](#).

Article 2

When registering vehicles after the entry into force of this Decision, Member States shall use the common specifications laid down in the Annex.

Article 3

Member States shall register existing vehicles as provided for in section 4 of the Annex.

Article 4

1 In accordance with Article 14(4)(b) of Directive 96/48/EC and Article 14(4)(b) of Directive 2001/16/EC, Member States shall designate a national body which shall be responsible for the keeping and updating of the National Vehicle Register. This body can be the National Safety Authority of the Member State concerned. Member States shall ensure that these bodies cooperate and share information in order to ensure that data changes are communicated in a timely manner.

2 Member States shall inform the Commission and the other Member States, within one year of the entry into force of this decision, of the body designated in accordance with paragraph 1.

Article 5

1 Rolling stock placed in service for the first time in Estonia, Latvia or Lithuania and intended to be used outside the European Union as part of common 1 520 mm rail system wagons fleet shall be registered in both the NVR and the Information Database of the Council of Railway Transport of the Commonwealth of Independent States. In this case, the 8-digit numbering system may be applied instead of the numbering system specified in the Annex.

2 Rolling stock placed in service for the first time in a third country and intended to be used inside the European Union as part of the common 1 520 mm rail system wagons fleet shall not be registered in the NVR. However, in conformity with article 14(4) of Directive 2001/16/EC, it must be possible to retrieve information listed in Article 14(5)(c), (d) and (e) from the Information Database of the CIS Council of Railway Transport.

Article 6

This Decision is addressed to the Member States.

Status: Point in time view as at 31/01/2020.

Changes to legislation: There are currently no known outstanding effects for the Commission Decision of 9 November 2007 adopting a common specification of the national vehicle register provided for under Articles 14(4) and (5) of Directives 96/48/EC and 2001/16/EC (notified under document number C(2007) 5357) (2007/756/EC). (See end of Document for details)

[^{F2}ANNEX

Textual Amendments

F2 Substituted by [Commission Decision of 10 February 2011 amending Decision 2007/756/EC adopting a common specification of the national vehicle register \(notified under document C\(2011\) 665\) \(Text with EEA relevance\) \(2011/107/EU\)](#).

1. DATA

The data format of the national vehicle register (hereinafter referred to as ‘NVR’) is as follows.

The item numbering follows the logic of the proposed standard registration form in Appendix 4.

In addition, field(s) may be added such as comments, identification of vehicles under investigation (see Section 3.4), etc.

1.	[^{F3}Numeric identification code as defined in Appendix 6]	Compulsory
Content	Numeric identification code as defined in Annex P to the Technical Specification for Interoperability (TSI) on ‘operation and traffic management’ (hereinafter referred to as ‘OPE TSI’) ^a	
Format	1.1. Number	12 digits
	1.2. Previous number (if applicable, for renumbered vehicle)	
2.	Member State and NSA	Compulsory
Content	Identification of the Member State where the vehicle has been registered and NSA that authorised its placing in service	
Format	2.1. [^{F3} Member State numeric code]	Two-digit code

a [^{F3}Not used.]

b For vehicle types authorised in accordance with Article 26 of Directive 2008/57/EC.

c The register provided for in Article 34 of Directive 2008/57/EC.

d Authorisation delivered in accordance with Chapter V of Directive 2008/57/EC or authorisation delivered in accordance with the authorisation regimes existing before transposition of Directive 2008/57/EC.

Status: Point in time view as at 31/01/2020.

Changes to legislation: There are currently no known outstanding effects for the Commission Decision of 9 November 2007 adopting a common specification of the national vehicle register provided for under Articles 14(4) and (5) of Directives 96/48/EC and 2001/16/EC (notified under document number C(2007) 5357) (2007/756/EC). (See end of Document for details)

	as defined in Appendix 6, part 4]	
	2.2. Name of NSA	Text
3.	Manufacturing year	Compulsory
Content	Year in which the vehicle left the factory	
Format	3. Manufacturing year	YYYY
4.	EC reference	Compulsory (when available)
Content	References to the 'EC' declaration of verification and the issuing body (the applicant)	
Format	4.1. Date of declaration	Date
	4.2. EC reference	Text
	4.3. Name of issuing body (applicant)	Text
	4.4. Registered business number	Text
	4.5. Address of organisation, street and number	Text
	4.6. Town	Text
	4.7. Country code	ISO (see Appendix 2)
	4.8. Post code	Alphanumeric code
5.	Reference to the European Register of Authorised Types of Vehicles (ERATV)	Compulsory^b
Content	Reference allowing retrieval of the relevant technical data from ERATV ^c ; the reference	

a [^{F3}Not used.]

b For vehicle types authorised in accordance with Article 26 of Directive 2008/57/EC.

c The register provided for in Article 34 of Directive 2008/57/EC.

d Authorisation delivered in accordance with Chapter V of Directive 2008/57/EC or authorisation delivered in accordance with the authorisation regimes existing before transposition of Directive 2008/57/EC.

Status: Point in time view as at 31/01/2020.

Changes to legislation: There are currently no known outstanding effects for the Commission Decision of 9 November 2007 adopting a common specification of the national vehicle register provided for under Articles 14(4) and (5) of Directives 96/48/EC and 2001/16/EC (notified under document number C(2007) 5357) (2007/756/EC). (See end of Document for details)

	is compulsory if the type is defined in ERATV	
Format	5. Reference allowing retrieval of the relevant technical data from ERATV	Alphanumeric code(s)
5bis	Series	Optional
Content	Identification of a series, if the vehicle is part of a series	
	5bis Series	Text
6.	Restrictions	Compulsory
Content	Any restrictions on how the vehicle may be used	
Format	6.1. Coded restrictions (see Appendix 1)	Code
	6.2. Non-coded restrictions	Text
7.	Owner	Compulsory
Content	Identification of the owner of the vehicle	
Format	7.1. Name of organisation	Text
	7.2. Registered business number	Text
	7.3. Address of organisation, street and number	Text
	7.4. Town	Text
	7.5. Country code	ISO (see Appendix 2)
	7.6. Post code	Alphanumeric code
8.	Keeper	Compulsory
a	[^{F3} Not used.]	
b	For vehicle types authorised in accordance with Article 26 of Directive 2008/57/EC.	
c	The register provided for in Article 34 of Directive 2008/57/EC.	
d	Authorisation delivered in accordance with Chapter V of Directive 2008/57/EC or authorisation delivered in accordance with the authorisation regimes existing before transposition of Directive 2008/57/EC.	

Status: Point in time view as at 31/01/2020.

Changes to legislation: There are currently no known outstanding effects for the Commission Decision of 9 November 2007 adopting a common specification of the national vehicle register provided for under Articles 14(4) and (5) of Directives 96/48/EC and 2001/16/EC (notified under document number C(2007) 5357) (2007/756/EC). (See end of Document for details)

Content	Identification of the keeper of the vehicle	
Format	8.1. Name of organisation	Text
	8.2. Registered business number	Text
	8.3. Address of organisation, street and number	Text
	8.4. Town	Text
	8.5. Country code	ISO (see Appendix 2)
	8.6. Post code	Alphanumeric code
	8.7. VKM (if available)	Alphanumeric code
9.	Entity in charge of maintenance	Compulsory
Content	Reference to the entity in charge of maintenance	
Format	9.1. Entity in charge of maintenance	Text
	9.2. Registered business number	Text
	9.3. Address of entity, street and number	Text
	9.4. Town	Text
	9.5. Country code	ISO
	9.6. Post code	Alphanumeric code
	9.7. E-mail address	E-mail
10.	Withdrawal	Compulsory when applicable

a [^{F3}Not used.]

b For vehicle types authorised in accordance with Article 26 of Directive 2008/57/EC.

c The register provided for in Article 34 of Directive 2008/57/EC.

d Authorisation delivered in accordance with Chapter V of Directive 2008/57/EC or authorisation delivered in accordance with the authorisation regimes existing before transposition of Directive 2008/57/EC.

Status: Point in time view as at 31/01/2020.

Changes to legislation: There are currently no known outstanding effects for the Commission Decision of 9 November 2007 adopting a common specification of the national vehicle register provided for under Articles 14(4) and (5) of Directives 96/48/EC and 2001/16/EC (notified under document number C(2007) 5357) (2007/756/EC). (See end of Document for details)

Content	Date of official scrapping and/or other disposal arrangement and the code for withdrawal mode	
Format	10.1. Mode of disposal (see Appendix 3)	Two-digit code
	10.2. Withdrawal date	Date
11.	Member States where the vehicle is authorised	Compulsory
Content	List of Member States where the vehicle is authorised	
Format	11. [F3Member State numeric code as defined in Appendix 6, part 4]	List
12.	Authorisation number	Compulsory
Content	Harmonised authorisation number for placing in service, generated by NSA	
Format	12. Authorisation number	For existing vehicles: text For new vehicles: alphanumeric code based on EIN, see Appendix 2
13.	Authorisation of placing in service	Compulsory
Content	Date of authorisation for placing the vehicle in service ^d and its validity	
Format	13.1. Date of authorisation	Date (YYYYMMDD)
	13.2. Authorisation valid until (if specified)	Date (YYYYMMDD)
	13.3. Suspension of authorisation	Yes/No

a [F3Not used.]

b For vehicle types authorised in accordance with Article 26 of Directive 2008/57/EC.

c The register provided for in Article 34 of Directive 2008/57/EC.

d Authorisation delivered in accordance with Chapter V of Directive 2008/57/EC or authorisation delivered in accordance with the authorisation regimes existing before transposition of Directive 2008/57/EC.

Status: Point in time view as at 31/01/2020.

Changes to legislation: There are currently no known outstanding effects for the Commission Decision of 9 November 2007 adopting a common specification of the national vehicle register provided for under Articles 14(4) and (5) of Directives 96/48/EC and 2001/16/EC (notified under document number C(2007) 5357) (2007/756/EC). (See end of Document for details)

Textual Amendments

- F3** Substituted by Commission Decision of 14 November 2012 concerning the technical specification for interoperability relating to the ‘operation and traffic management’ subsystem of the rail system in the European Union and amending Decision 2007/756/EC (notified under document C(2012) 8075) (Text with EEA relevance) (2012/757/EU).

2. ARCHITECTURE

2.1. Links with other registers

Several registers are being set up partly as a consequence of the new EU regulatory regime. The table below summarises which registers and databases might have links with the NVR when they are implemented.

Register or database	Entity responsible	Other entities having access
NVR (Interoperability Directive)	Registration Entity (RE) ^a / NSA	Other NSA/RE/RU/IM/IB/ RB/Keeper/Owner/ERA/ OTIF
ERATV (Interoperability Directive)	ERA	Public
RSRD (TAF TSI & SEDP)	Keeper	RU/IM/NSA/ERA/Keeper/ Workshops
WIMO (TAF TSI & SEDP)	Not yet decided	RU/IM/NSA/ERA/Keeper/ Workshops/User
Railway rolling stock registry ^b (Cape Town Convention)	Registrar	Public
OTIF register (COTIF 99 — ATMF)	OTIF	Competent Authorities/RU/ IM/IB/RB/Keeper/Owner/ ERA/OTIF Sec.

a The Registration Entity (‘RE’) is the entity designated by each Member State, in accordance with Article 33(1)(b) of Directive 2008/57/EC, for keeping and updating the NVR.

b As provided for in the Luxembourg Protocol to the Convention on International Interests in Mobile Equipment on matters specific to railway rolling stock, signed in Luxembourg on 23 February 2007.

It is not possible to wait for all registers to be ready before implementing the NVR. Therefore, the specification of the NVR must allow for later interfacing with these other registers. To this end:

- ERATV: reference is made to this in the NVR, by providing a reference to the vehicle type. The key for linking both registers is item No 5,
- RSRD: this includes some ‘administrative’ items of the NVR. Under specification within the TAF TSI SEDP. The SEDP will take account of the NVR specification,
- WIMO: this includes data from RSRD and maintenance data. No link with the NVR is envisaged,
- ^{F3}VKMR: this register is managed by ERA and OTIF in cooperation (ERA for the EU and OTIF for all non-EU OTIF Member States). The keeper is recorded in the

Status: Point in time view as at 31/01/2020.

Changes to legislation: *There are currently no known outstanding effects for the Commission Decision of 9 November 2007 adopting a common specification of the national vehicle register provided for under Articles 14(4) and (5) of Directives 96/48/EC and 2001/16/EC (notified under document number C(2007) 5357) (2007/756/EC). (See end of Document for details)*

- NVR. Appendix 6 specifies other global central registers (such as vehicle type codes, interoperability codes, country codes, etc.) to be managed by a ‘central body’ resulting from cooperation between ERA and OTIF,]
- railway rolling stock registry (Cape Town Convention/Luxembourg Protocol): this is a register of financial information related to mobile equipment. It has not yet been developed. There is a possible link because the UNIDROIT register needs information on the vehicle number and owner. The key for linking both registers is the first EVN assigned to the vehicle,
 - OTIF registers: OTIF registers are being developed taking account of the EU vehicle registers.

The architecture of the whole system, as well as the links between the NVR and other registers, will be defined in such a way as to allow retrieval of the requested information when necessary.

2.2. The EU global NVR architecture

The NVR registers will be implemented by means of a decentralised solution. The objective is to implement a search engine for distributed data, using a common software application, to allow users to retrieve data from all the Local Registers (LR) in the Member States.

NVR data will be stored at national level and will be accessible using a web-based application (with its own web address).

The European Centralised Virtual Vehicle Register (EC VVR) will be composed of two sub-systems:

- the Virtual Vehicle Register (VVR), which is the central search engine in ERA,
- the National Vehicle Register(s) (NVR), which are the LR in the Member States. The Member States can use the standard NVR (sNVR) developed by the Agency or develop their own applications in conformity with this specification. In the latter case, for communication by the NVR with the VVR the Member States will use a Translation Engine (TE) developed by the Agency.

Figure 1

Status: Point in time view as at 31/01/2020.

Changes to legislation: There are currently no known outstanding effects for the Commission Decision of 9 November 2007 adopting a common specification of the national vehicle register provided for under Articles 14(4) and (5) of Directives 96/48/EC and 2001/16/EC (notified under document number C(2007) 5357) (2007/756/EC). (See end of Document for details)

EC-VVR architecture

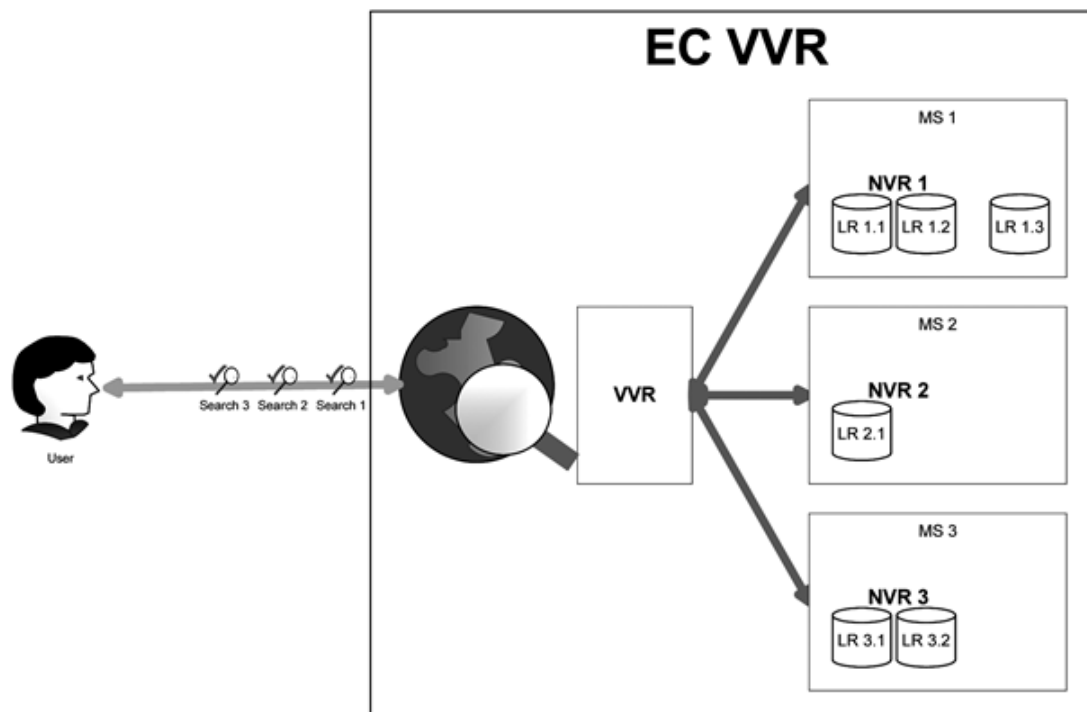

This architecture is based on two complementary sub-systems to enable searches on data stored locally in all Member States. It will:

- establish computerised registers at national level and open them to cross-consultation,
- replace paper registers by computerised records, to allow the Member States to manage and share information with other Member States,
- allow connections between the NVRs and the VVR, using common standards and terminology.

The main principles of this architecture are as follows:

- all NVRs will be part of the computer based network system,
- all Member States will view the common data when accessing the system,
- double registration of data and possible related errors will be avoided once the VVR has been established,
- up-to-date data.

The Agency will make available to the REs the following installation files and documents to be used for setting up the sNVR and TE and for connecting them to the central VVR:

- installation files:
 - sNVR_Installation_Files,
 - TE_Installation_Files,
- documents:
 - Administrator_Guide_sNVR,
 - CSV_export,
 - CSV_import,
 - sNVR_Deployment_Guide,
 - User_Guide_sNVR,

Status: Point in time view as at 31/01/2020.

Changes to legislation: There are currently no known outstanding effects for the Commission Decision of 9 November 2007 adopting a common specification of the national vehicle register provided for under Articles 14(4) and (5) of Directives 96/48/EC and 2001/16/EC (notified under document number C(2007) 5357) (2007/756/EC). (See end of Document for details)

- NVR-TE_Deployment_Guide,
- NVR-TE_Integration_Guide,
- User_Guide_VVR.

3. OPERATING MODE

3.1. Use of the NVR

The NVR is to be used for the following purposes:

- recording authorisation,
- recording the EVN allocated to vehicles,
- looking for brief, European-wide information on a particular vehicle,
- following up legal aspects such as obligations and legal information,
- retrieving information for inspections mainly related to safety and maintenance,
- enabling contact with the owner and keeper,
- cross-checking some safety requirements before issuing Safety Certificates,
- following up a particular vehicle.

3.2. Application forms

[^{F4}3.2.1. *Application for registration*

The form in Appendix 4 shall be used for the application for registration.

The entity applying for vehicle registration shall tick the ‘New registration’ box. It shall fill in the form and forward it to the:

- RE of the Member State where registration is sought, filling in all fields,
- RE of the first Member State where it intends to operate, for a vehicle coming from a third country (see point 3.2.5(2)). In that case the form shall contain at least the information on the identification of the owner of the vehicle and the keeper, the restrictions on how the vehicle may be used, the entity in charge of maintenance.]

Textual Amendments

- F4** Substituted by [Commission Implementing Decision \(EU\) 2018/1614 of 25 October 2018 laying down specifications for the vehicle registers referred to in Article 47 of Directive \(EU\) 2016/797 of the European Parliament and of the Council and amending and repealing Commission Decision 2007/756/EC \(Text with EEA relevance\).](#)

3.2.2. *Registering a vehicle and issuing a European Vehicle Number.*

In the case of first registration, the RE concerned issues the European Vehicle number.

It is possible to have a separate registration form per vehicle or a single form for a whole set of vehicles of the same series or order with a list of the vehicle numbers attached.

The RE must take reasonable steps to ensure the accuracy of the data it enters in the NVR. To this end the RE can request information from other REs, in particular when the entity applying for registration in a Member State is not established in that Member State.

3.2.3. *Changing one or more registration item(s)*

The entity applying for a change to its vehicle registration item(s):

- ticks the ‘Modification’ box,

Status: Point in time view as at 31/01/2020.

Changes to legislation: There are currently no known outstanding effects for the Commission Decision of 9 November 2007 adopting a common specification of the national vehicle register provided for under Articles 14(4) and (5) of Directives 96/48/EC and 2001/16/EC (notified under document number C(2007) 5357) (2007/756/EC). (See end of Document for details)

- fills in the current EVN (item No 0),
- ticks the box(es) before the modified item(s),
- enters the new content of the modified item(s), and then forwards the form to the REs of all the Member States where the vehicle is registered.

The use of the standard form might not be sufficient for certain cases. If necessary, the RE concerned may therefore submit additional documents in either paper or electronic form.

Unless otherwise specified in the registration documents, the keeper of the vehicle is considered to be the ‘registration holder’ in the meaning of Article 33(3) of Directive 2008/57/EC.

Should a keeper change, it is the responsibility of the currently registered keeper to notify the RE and the RE has to notify the new keeper of the change of registration. The former keeper is removed from the NVR and relieved of its responsibilities only when the new keeper has acknowledged its acceptance of keeper status. If on the date of de-registration of the currently registered keeper no new keeper has accepted the keeper status, the registration of the vehicle is suspended.

In cases where, in accordance with the OPE TSI, due to technical changes, the vehicle has to be given a new EVN, the registration holder shall inform of these changes and, if applicable, of the new authorisation for placing in service the RE of the Member State where the vehicle is registered. This RE shall assign to the vehicle a new EVN.

[^{F5}The RE shall register the changes in the NVR within 20 working days from the receipt of a complete application file. The RE shall, within this deadline, either register the vehicle or request correction/clarification.]

Textual Amendments

- F5** Inserted by [Commission Implementing Decision \(EU\) 2018/1614 of 25 October 2018 laying down specifications for the vehicle registers referred to in Article 47 of Directive \(EU\) 2016/797 of the European Parliament and of the Council and amending and repealing Commission Decision 2007/756/EC \(Text with EEA relevance\).](#)

3.2.4. *Withdrawal of registration*

The entity applying for withdrawal of registration ticks the ‘Withdrawal’ box. It then fills in item No 10 and forwards the form to the REs of all the Member States where the vehicle is registered.

The RE delivers the withdrawal registration by filling in the date of withdrawal and acknowledging the withdrawal to the entity.

[^{F4}3.2.5. *Authorisation in several Member States*

1. Vehicles shall be registered only in the NVR of the Member State where they are first authorised for placing in service or, for vehicles to which an authorisation for placing on the market has been issued in accordance with Directive (EU) 2016/797 of the European Parliament and of the Council⁽⁴⁾, only in a Member State in the area of use of the authorisation for placing on the market, without prejudice to the transfer of registration to a different NVR in accordance with point 3.2.6(2).
2. Vehicles entering the Union rail system from third countries and registered in a vehicle register not in line with this specification or not connected to EC VVR shall be registered only in the NVR of the first Member State where the vehicle is intended to be operated on the Union rail system.

Status: Point in time view as at 31/01/2020.

Changes to legislation: There are currently no known outstanding effects for the Commission Decision of 9 November 2007 adopting a common specification of the national vehicle register provided for under Articles 14(4) and (5) of Directives 96/48/EC and 2001/16/EC (notified under document number C(2007) 5357) (2007/756/EC). (See end of Document for details)

3. Vehicles entering the Union rail system from third countries and registered in a vehicle register in line with this specification and connected to the EC VVR, when an international agreement to which the European Union is party provides for that, shall not be registered in any NVR.
4. For any vehicle, the NVR where it is registered shall contain the data relating to items 2, 6, 12 and 13 for each of the Member States where an authorisation for placing in service has been granted to this vehicle.

This provision is without prejudice to Articles 3 and 5.]

[^{F5}3.2.6. *Transfer of registration and change of EVN*

1. The EVN shall be changed when it does not reflect the interoperability capability or technical characteristics in accordance with Appendix 6 due to technical modifications of the vehicle. Such technical modifications may require a new authorisation for placing in service in accordance with Articles 21 to 26 of Directive 2008/57/EC of the European Parliament and of the Council⁽⁵⁾ or a new authorisation for placing on the market and, where appropriate, a new vehicle type authorisation, in accordance with Articles 21 and 24 of Directive (EU) 2016/797. The keeper shall inform the RE of the Member State where the vehicle is registered of those changes and, if applicable, of the new authorisation for placing in service or of a new authorisation for placing on the market. That RE shall assign to the vehicle a new EVN.
2. The EVN may be changed at the request of the keeper through a new registration of the vehicle in the NVR of a different Member State connected to EC VVR and subsequent withdrawal of the old registration.]

[^{F4}3.3. **Access rights**

The access rights to data of an NVR from a given Member State 'XX' are listed in the table below:

Entity	Read rights	Update rights
RE of Member State 'XX'	All data	All data in vehicle register of MS 'XX'
NSA	All data	None
Agency	All data	None
Keeper	All data on vehicles of which it is keeper	None
ECM	All data, except owner's references, of vehicles for which it is ECM	None
Owner	All data on vehicles of which it is owner	None

a Directive (EU) 2016/798 of the European Parliament and of the Council of 11 May 2016 on railway safety (OJ L 138, 26.5.2016, p. 102).

b Directive 2012/34/EU of the European Parliament and of the Council of 21 November 2012 establishing a single European railway area (OJ L 343, 14.12.2012, p. 32).

c The Agency shall, in cooperation with the NSAs, define the procedure for recognising legitimate users.

Status: Point in time view as at 31/01/2020.

Changes to legislation: There are currently no known outstanding effects for the Commission Decision of 9 November 2007 adopting a common specification of the national vehicle register provided for under Articles 14(4) and (5) of Directives 96/48/EC and 2001/16/EC (notified under document number C(2007) 5357) (2007/756/EC). (See end of Document for details)

Railway undertaking	All data, except owner's references, based on one or more vehicle numbers	None
Infrastructure manager	All data, except owner's references, based on one or more vehicle numbers	None
Investigating body referred to in Article 22 of Directive (EU) 2016/798 of the European Parliament and of the Council ^a and regulatory body referred to in Article 55 of Directive 2012/34/EU of the European Parliament and of the Council ^b	All data on vehicles being checked or audited	None
EC declaration of verification issuing body (the applicant)	All data on vehicles of which it is EC declaration of verification issuing body (the applicant), except owner's references	None
Other legitimate user recognised by NSA or the Agency ^c	To be defined as appropriate, duration possibly limited, except owner's references	None

^a Directive (EU) 2016/798 of the European Parliament and of the Council of 11 May 2016 on railway safety (OJ L 138, 26.5.2016, p. 102).

^b Directive 2012/34/EU of the European Parliament and of the Council of 21 November 2012 establishing a single European railway area (OJ L 343, 14.12.2012, p. 32).

^c The Agency shall, in cooperation with the NSAs, define the procedure for recognising legitimate users.

The access rights to data of NVRs may be extended to relevant third country entities or intergovernmental organisation when an international agreement to which the European Union is party provides for that.]

3.4. Historical records

All data in the NVR must be retained for 10 years from the date of withdrawal of a vehicle registration. As a minimum, data must be available online for the first 3 years. After 3 years, data may be kept either electronically, in paper form or in any other archiving system. If at any time during the 10-year period an investigation involving a vehicle or vehicles is started, data relating to these vehicles must be retained beyond the 10-year period if so required.

After withdrawal of a vehicle registration, any of the registration numbers assigned to the vehicle must not be assigned to any other vehicle for 100 years from the date the vehicle is withdrawn.

Any changes in the NVR should be recorded. The management of historical changes could be addressed by IT solutions.

4. EXISTING VEHICLES

4.1. Data content

Status: Point in time view as at 31/01/2020.

Changes to legislation: *There are currently no known outstanding effects for the Commission Decision of 9 November 2007 adopting a common specification of the national vehicle register provided for under Articles 14(4) and (5) of Directives 96/48/EC and 2001/16/EC (notified under document number C(2007) 5357) (2007/756/EC). (See end of Document for details)*

The 13 data items retained are listed below, with an indication as to which are compulsory and which are not.

4.1.1. *Item No 1 — European Vehicle Number (Compulsory)*

(a) Vehicles already possessing a 12-digit number

Countries where there is a unique country code:

These vehicles should keep their current number. The 12-digit number should be registered as such without any modification.

Countries where there is both a main country code and a previously allocated specific code:

- Germany, with the main country code 80 and the specific code 68 for AAE (Ahaus Alstätter Eisenbahn),
- Switzerland, with the main country code 85 and the specific code 63 for BLS (Bern-Lötschberg-Simplon Eisenbahn),
- Italy, with the main country code 83 and the specific code 64 for FNME (Ferrovie Nord Milano Esercizio),
- Hungary, with the main country code 55 and the specific code 43 for GySEV/ROeEE (Győr-Sopron-Ebenfurti Vasút Részvénytársaság/Raab-Ödenburg-Ebenfurter Eisenbahn).

These vehicles should keep their current number. The 12-digit number should be registered as such without any modification⁽⁶⁾.

The IT system has to consider both codes (main country code and specific code) as relating to the same country.

(b) Vehicles without a 12-digit number

A two-step procedure applies.

- A 12-digit number (according to OPE TSI) defined in accordance with the vehicle's characteristics is allocated in the NVR. The IT system should link this registered number to the current vehicle number.
- For vehicles used in international traffic, except those reserved for historical use: the 12-digit number is physically applied to the vehicle itself within a period of 6 years after allocation in the NVR. For vehicles used in domestic traffic and for those reserved for historical use: the physical application of the 12-digit number is voluntary.

4.1.2. *Item No 2 — Member State and NSA (Compulsory)*

The item 'Member State' must always refer to the Member State where the vehicle is registered in its NVR. For vehicles from third countries, this item refers to the first Member State that authorised the vehicle to be placed in service on the European Union rail network. The item 'NSA' refers to the entity that delivered the authorisation for placing the vehicle in service.

4.1.3. *Item No 3 — Manufacturing Year*

Where the manufacturing year is not known precisely, the approximate year should be entered.

4.1.4. *Item No 4 — EC Reference*

Normally such a reference does not exist for existing vehicles except for a handful of HS RS. To be recorded only if available.

4.1.5. *Item No 5 — Reference to the ERATV*

Status: Point in time view as at 31/01/2020.

Changes to legislation: There are currently no known outstanding effects for the Commission Decision of 9 November 2007 adopting a common specification of the national vehicle register provided for under Articles 14(4) and (5) of Directives 96/48/EC and 2001/16/EC (notified under document number C(2007) 5357) (2007/756/EC). (See end of Document for details)

To be recorded only if available.

Until ERATV is set up, reference may be made to the Rolling Stock Register (Article 22a of Council Directive 96/48/EC⁽⁷⁾ and Article 24 of Directive 2001/16/EC of the European Parliament and of the Council⁽⁸⁾).

4.1.6. *Item No 6 — Restrictions*

To be recorded only if available.

4.1.7. *Item No 7 — Owner (Compulsory)*

Compulsory and normally available.

4.1.8. *Item No 8 — Keeper (Compulsory)*

Compulsory and normally available. The VKM (unique code as indicated in the VKM register) must be entered if the keeper has it.

4.1.9. *Item No 9 — Entity in charge of maintenance (Compulsory)*

This item is compulsory.

4.1.10. *Item No 10 — Withdrawal*

Applicable as appropriate.

4.1.11. *Item No 11 — Member States where the vehicle is authorised*

Normally, RIV wagons, RIC coaches and vehicles under bilateral or multilateral agreements are registered as such. If this information is available it should be recorded accordingly.

4.1.12. *Item No 12 — Authorisation number*

To be recorded only if available

4.1.13. *Item No 13 — Placing in service (Compulsory)*

Where the date of placing into service is not known precisely, the approximate year should be entered.

4.2. **Procedure**

The entity previously responsible for vehicle registration is to make all information available to the NSA or RE of the country where it is located.

Existing freight wagons and passenger cars are to be registered only in the NVR of the Member State where the former registration entity was located.

If an existing vehicle had been authorised in several Member States, the RE that registers this vehicle sends the relevant data to the REs of the other Member States concerned.

The NSA or RE includes the information in its NVR.

The NSA or RE informs all the parties involved when the information transfer is completed. At least the following entities are to be informed:

- the entity previously responsible for vehicle registration,
- the keeper,
- ERA.

Status: Point in time view as at 31/01/2020.

Changes to legislation: There are currently no known outstanding effects for the Commission Decision of 9 November 2007 adopting a common specification of the national vehicle register provided for under Articles 14(4) and (5) of Directives 96/48/EC and 2001/16/EC (notified under document number C(2007) 5357) (2007/756/EC). (See end of Document for details)

[^{F4} Appendix 1

RESTRICTION CODING

1. PRINCIPLES

The restrictions referred to in the authorisation for placing in service in accordance with Articles 21 to 26 of Directive 2008/57/EC or in the authorisation for placing on the market and, where appropriate, a new vehicle type authorisation, in accordance with Articles 21 and 24 of Directive (EU) 2016/797 shall be assigned a harmonised code or a national code.

2. STRUCTURE

Each code is a combination of:

- category of restriction,
- type of restriction,
- value or specification,

which are joined by a dot (.):

[Category].[Type].[Value or specification].

3. RESTRICTION CODES

1. Harmonised restriction codes shall be applicable in all the Member States.

The Agency shall keep up-to-date and publish on its web site the list of harmonised restriction codes for the whole of the Union rail system.

If a national safety authority considers that a new code needs to be added to the list of harmonised restriction codes, it shall request the Agency to evaluate the inclusion of this new code.

The Agency shall evaluate the request, in consultation with other national safety authorities, where appropriate. When appropriate, the Agency shall include a new restriction code in the list.

2. The Agency shall keep up-to-date the list of national restriction codes. The use of national restriction codes shall be limited to those restrictions that reflect particular characteristics of the existing rail system of a Member State and are unlikely to be applied with the same meaning in other Member States.

For types of restrictions not indicated in the list referred to in point 1, the national safety authority shall request the Agency the inclusion of a new code in the list of national restriction codes. The Agency shall evaluate the request, where appropriate in consultation with other national safety authorities. If appropriate, the Agency shall include a new restriction code in the list.

3. The restriction code for multinational safety authorities shall be treated as national restriction code.
4. The use of non-coded restrictions shall be limited to those restrictions that due to their particular character are unlikely to be applied to several types of vehicle.

The Agency shall keep a unique list of restriction codes for the EVR, the European register of authorised types of vehicles referred to in Article 48 of Directive (EU) 2016/797, the one-stop shop and the European Railway Agency Database of Interoperability and Safety.

5. Where relevant, the Agency may coordinate the process of harmonisation of restriction codes with relevant intergovernmental organisation when an international agreement to which the European Union is party provides for that.

Status: Point in time view as at 31/01/2020.

Changes to legislation: There are currently no known outstanding effects for the Commission Decision of 9 November 2007 adopting a common specification of the national vehicle register provided for under Articles 14(4) and (5) of Directives 96/48/EC and 2001/16/EC (notified under document number C(2007) 5357) (2007/756/EC). (See end of Document for details)

Appendix 2

STRUCTURE AND CONTENT OF THE EUROPEAN IDENTIFICATION NUMBER

The Agency shall set out the structure and content of the European Identification Number (EIN), including the codification of the types of documents concerned, in a technical document and shall publish this technical document on its web site.]

Status: Point in time view as at 31/01/2020.

Changes to legislation: There are currently no known outstanding effects for the Commission Decision of 9 November 2007 adopting a common specification of the national vehicle register provided for under Articles 14(4) and (5) of Directives 96/48/EC and 2001/16/EC (notified under document number C(2007) 5357) (2007/756/EC). (See end of Document for details)

Appendix 3

WITHDRAWAL CODING

Code	Withdrawal mode	Description
00	None	The vehicle has a valid registration.
10	Registration suspended No reason specified	The vehicle's registration is suspended at the request of the owner or keeper or by a decision of the NSA or RE.
11	Registration suspended	The vehicle is destined for storage in working order as an inactive or strategic reserve.
20	Registration transferred	The vehicle is known to be reregistered under a different number or by a different NVR, for continued use on (all or part of) the European railway network.
30	Withdrawal No reason specified	The vehicle's registration for operating on the European railway network has ended without known reregistration.
31	Withdrawal	The vehicle is destined for continued use as a rail vehicle outside the European railway network.
32	Withdrawal	The vehicle is destined for the recovery of major interoperable constituents/modules/spares or major rebuilding.
33	Withdrawal	The vehicle is destined for scrapping and disposal of materials (including major spares) for recycling.
34	Withdrawal	The vehicle is destined to be 'historic preserved rolling stock' for operation on a segregated network, or for static display, outside the European railway network.

Use of codes

- If the reason for withdrawal is not specified, codes 10, 20 and 30 are to be used to indicate the change of registration status.

Status: Point in time view as at 31/01/2020.

Changes to legislation: There are currently no known outstanding effects for the Commission Decision of 9 November 2007 adopting a common specification of the national vehicle register provided for under Articles 14(4) and (5) of Directives 96/48/EC and 2001/16/EC (notified under document number C(2007) 5357) (2007/756/EC). (See end of Document for details)

- If the reason for withdrawal is available, codes 11, 31, 32, 33 and 34 are options available within the NVR database. These codes are based solely on information provided by the keeper or owner to the RE.

Registration issues

- A vehicle that has its registration suspended or withdrawn may not operate on the European railway network under the recorded registration.
- A reactivation of a registration after suspension will require the verification by the registration entity of the conditions which caused the suspension.
- A transfer of registration under the conditions set out in Article 1b of Commission Decision 2006/920/EC⁽⁹⁾ and Article 1b of Commission Decision 2008/231/EC⁽¹⁰⁾, as amended by Decision 2010/640/EU⁽¹¹⁾, consists of a new registration of the vehicle and subsequent withdrawal of the old registration.

Status: Point in time view as at 31/01/2020.

Changes to legislation: *There are currently no known outstanding effects for the Commission Decision of 9 November 2007 adopting a common specification of the national vehicle register provided for under Articles 14(4) and (5) of Directives 96/48/EC and 2001/16/EC (notified under document number C(2007) 5357) (2007/756/EC). (See end of Document for details)*

Appendix 4

STANDARD FORM FOR REGISTRATION

Status: Point in time view as at 31/01/2020.

Changes to legislation: *There are currently no known outstanding effects for the Commission Decision of 9 November 2007 adopting a common specification of the national vehicle register provided for under Articles 14(4) and (5) of Directives 96/48/EC and 2001/16/EC (notified under document number C(2007) 5357) (2007/756/EC). (See end of Document for details)*



Standard form for registration of authorised vehicles ⁽¹⁾

in conformity with Directive 2008/57/EC and applicable national legislation

Application for: New registration Modification ⁽²⁾ Withdrawal

INFORMATION ABOUT THE VEHICLE

1. Number

1.1. European Vehicle Number ⁽³⁾ _ _ _ _ _ - _ _

1.2. Number previously assigned to the vehicle ⁽⁴⁾

2. Member State where registration is sought and NSA that authorised the vehicle

2.1. Member State: _ _

2.2. Name of NSA:

3. Manufacturing year: _ _ _ _

4. EC reference

4.1. Date of declaration: _ _ _ _ _

4.2. EC reference:

4.3. Name of issuing body:

4.4. Registered business number:

Address of organisation

4.5. Street and number:

4.6. Town:

4.7. Country code: 4.8. Post code:.....

5. Reference to the European register of authorised types of vehicles:

5bis. **Series**

⁽¹⁾ This form may also be produced electronically.
⁽²⁾ The box before each modified item also has to be ticked.
⁽³⁾ Not applicable for first registration.
⁽⁴⁾ Not applicable for first registration.

Status: Point in time view as at 31/01/2020.

Changes to legislation: There are currently no known outstanding effects for the Commission Decision of 9 November 2007 adopting a common specification of the national vehicle register provided for under Articles 14(4) and (5) of Directives 96/48/EC and 2001/16/EC (notified under document number C(2007) 5357) (2007/756/EC). (See end of Document for details)

Status: Point in time view as at 31/01/2020.

Changes to legislation: There are currently no known outstanding effects for the Commission Decision of 9 November 2007 adopting a common specification of the national vehicle register provided for under Articles 14(4) and (5) of Directives 96/48/EC and 2001/16/EC (notified under document number C(2007) 5357) (2007/756/EC). (See end of Document for details)

Identification of the entity applying for registration:

Date: _ _ _ _ _

Name and signature of responsible officer:

SAFETY AUTHORITY REFERENCES

1.1. **Allocated European Vehicle Number** ⁽¹⁾ _ _ _ _ _

12. **Authorisation number** _ _ _ _ _

13. **Placing in service**

13.1. Date of authorisation: _ _ _ _ _

13.2. Authorisation valid until: _ _ _ _ _

Date application received: _ _ _ _ _

Date of withdrawal: _ _ _ _ _

⁽¹⁾ It is possible to attach a list for several vehicles of the same series or order.

Status: Point in time view as at 31/01/2020.

Changes to legislation: There are currently no known outstanding effects for the Commission Decision of 9 November 2007 adopting a common specification of the national vehicle register provided for under Articles 14(4) and (5) of Directives 96/48/EC and 2001/16/EC (notified under document number C(2007) 5357) (2007/756/EC). (See end of Document for details)

Appendix 5

GLOSSARY

Abbreviation	Definition
CCS	Control Command System
CIS	Commonwealth of Independent States
COTIF	Convention concerning International Carriage by Rail
CR	Conventional Rail (System)
DB	Database
EC	European Commission
EC VVR	European Centralised Virtual Vehicle Register
EIN	European Identification Number
EN	European Standard (Euro Norm)
EVN	European Vehicle Number
ERA	European Railway Agency, also referred to as 'the Agency'
ERATV	European Register of Authorised Types of Vehicles
ERTMS	European Rail Traffic Management System
EU	European Union
HS	High Speed (System)
IB	Investigating Body
ISO	International Organisation for Standardisation
IM	Infrastructure Manager
INF	Infrastructure
IT	Information Technology
LR	Local Register
NoBo	Notified Body
NSA	National Safety Authority
NVR	National Vehicle Register
OPE (TSI)	Operation and Traffic management (TSI)
OTIF	Intergovernmental Organisation for International Carriage by Rail

Status: Point in time view as at 31/01/2020.

Changes to legislation: There are currently no known outstanding effects for the Commission Decision of 9 November 2007 adopting a common specification of the national vehicle register provided for under Articles 14(4) and (5) of Directives 96/48/EC and 2001/16/EC (notified under document number C(2007) 5357) (2007/756/EC). (See end of Document for details)

RE	Registration Entity, i.e. the body responsible for keeping and updating the NVR
RB	Regulatory Body
RIC	Regulations governing the reciprocal use of carriages and brake vans in international traffic
RIV	Regulations concerning the reciprocal use of wagons in international traffic
RS or RST	Rolling Stock
RSRD (TAF)	Rolling Stock Reference Database (TAF)
RU	Railway Undertaking
SEDP (TAF)	Strategic European Deployment Plan (TAF)
TAF (TSI)	Telematic Applications for Freight (TSI)
TSI	Technical Specification for Interoperability
VKM	Vehicle Keeper Marking
VKMR	Vehicle Keeper Marking Register
VVR	Virtual Vehicle Register
WAG (TSI)	Wagon (TSI)
WIMO (TAF)	Wagon and Intermodal Operational Database (TAF)

Status: Point in time view as at 31/01/2020.

Changes to legislation: There are currently no known outstanding effects for the Commission Decision of 9 November 2007 adopting a common specification of the national vehicle register provided for under Articles 14(4) and (5) of Directives 96/48/EC and 2001/16/EC (notified under document number C(2007) 5357) (2007/756/EC). (See end of Document for details)

^{F1}Appendix 6

PART '0' —

VEHICLE IDENTIFICATION

General remarks

This appendix describes the European Vehicle Number and linked marking applied in a visible manner on the vehicle to identify it uniquely and in a permanent manner during operation. It does not describe other numbers or markings eventually engraved or fixed in a permanent manner on the chassis or the main components of the vehicle during its construction.

European Vehicle number and linked abbreviations

Each railway vehicle receives a number consisting of 12 figures (called European Vehicle Number (EVN)) with the following structure:

Rolling stock group	Interoperability and vehicle type [2 figures]	Country in which the vehicle is registered [2 figures]	Technical characteristics [3 figures]	Serial number [3 figures]	Check digit [1 figure]
Wagons	00 to 09 10 to 19 20 to 29 30 to 39 40 to 49 80 to 89 <i>[details in part 6]</i>	01 to 99 <i>[details in part 4]</i>	0000 to 9999 <i>[details in part 9]</i>	000 to 999	0 to 9 <i>[details in part 3]</i>
Hauled passenger vehicles	50 to 59 60 to 69 70 to 79 <i>[details in part 7]</i>		0000 to 9999 <i>[details in part 10]</i>	000 to 999	
Tractive rolling stock and units in a train set in fixed or pre-defined formation	90 to 99 <i>[details in part 8]</i>		0000000 to 8999999 <i>[the meaning of these figures is defined by the Member States, eventually by bilateral or multilateral agreement]</i>		
Special vehicles			9000 to 9999 <i>[details in part 11]</i>	000 to 999	

In a given country, the 7 digits of technical characteristics and serial number are sufficient to identify uniquely a vehicle inside the groups of hauled passenger vehicles and special vehicles⁽¹²⁾.

Alphabetical markings complete the number:

Status: Point in time view as at 31/01/2020.

Changes to legislation: There are currently no known outstanding effects for the Commission Decision of 9 November 2007 adopting a common specification of the national vehicle register provided for under Articles 14(4) and (5) of Directives 96/48/EC and 2001/16/EC (notified under document number C(2007) 5357) (2007/756/EC). (See end of Document for details)

- (a) abbreviation of the country in which the vehicle is registered (*details in part 4*);
- (b) Vehicle Keeper Marking (*details in part 1*);
- (c) abbreviations of the technical characteristics (*details in part 12 for the wagons, part 13 for the hauled passenger vehicles*).

The European Vehicle Number shall be changed when it does not reflect the interoperability capability or technical characteristics according to this Appendix due to technical modifications of the vehicle. Such technical modifications may require a new placing in service according to Articles 20 to 25 of Directive 2008/57/EC.

PART 1 —

VEHICLE KEEPER MARKING

[^{F4}1. **Definition of the Vehicle Keeper Marking (VKM)**

A Vehicle Keeper Marking (VKM) is an alphabetic code, consisting of 2 to 5 letters⁽¹³⁾. A VKM is inscribed on each rail vehicle, near the European Vehicle Number. The VKM identifies the Vehicle Keeper as registered in a National Vehicle Register.

A VKM is unique and valid in all Member States and all countries that enter into an agreement that involves the application of the system of vehicle numbering and VKM as set out in this Decision.]

2. **Format of the Vehicle Keeper Marking**

The VKM is representation of the full name or abbreviation of the vehicle keeper, if possible in a recognisable manner. All 26 letters of the Latin alphabet may be used. The letters in the VKM are written in capitals. Letters that do not stand for first letters of words in the keeper's name may be written in lower case. For checking uniqueness, the letters written in lower case will be taken as written in capitals.

Letters may contain diacritical signs⁽¹⁴⁾. Diacritical signs used by these letters are ignored for checking uniqueness.

For vehicles of keepers that reside in a country that does not use the Latin alphabet, a translation of the VKM in its own alphabet may be applied behind the VKM separated from it by a slash-sign ('/'). This translated VKM is disregarded for data-processing purposes.

3. **Provisions about allocation of Vehicle Keeper Markings**

A vehicle keeper can be issued more than one VKM, in case:

- the vehicle keeper has a formal name in more than one language;
- a vehicle keeper has good cause to distinguish between separate vehicle fleets within his organisation.

A single VKM can be issued for a group of companies:

- that belong to single corporate structure (e.g. holding structure);
- that belong to a single corporate structure that has appointed and mandated one organisation within this structure to handle all issues on behalf of all others;
- that has mandated a separate, single legal entity for handling all issues on their behalf, in which event the legal entity is the keeper.

Status: Point in time view as at 31/01/2020.

Changes to legislation: There are currently no known outstanding effects for the Commission Decision of 9 November 2007 adopting a common specification of the national vehicle register provided for under Articles 14(4) and (5) of Directives 96/48/EC and 2001/16/EC (notified under document number C(2007) 5357) (2007/756/EC). (See end of Document for details)

4. Register of Vehicle Keeper Markings and procedure for allocation

The register of VKM is public and updated on a real time basis.

An application for a VKM is filed with the applicant's competent national authority and forwarded to the ERA. A VKM can be used only after publication by the ERA.

The holder of a VKM must inform the competent national authority when he ends the use of a VKM, and the competent national authority will forward the information to the ERA. A VKM will then be revoked once the keeper has proved that the marking has been changed on all vehicles concerned. It will not be reissued for 10 years, unless it is reissued to the original holder or at his request to another holder.

A VKM can be transferred to another holder, which is the legal successor to the original holder. A VKM stays valid when the VKM's holder changes his name to a name that does not bear resemblance to the VKM.

In case of a change of keeper which entails a change of VKM, the vehicles concerned must be marked with the new VKM within three months from the date of registration of the change of keeper in the National Vehicle Register. In case of inconsistency between the VKM marked on the vehicle and the data registered in the NVR, the NVR-registration supersedes.

PART 2

Not used

PART 3 —

RULES FOR THE DETERMINATION OF THE CHECK-DIGIT (DIGIT 12)

The check-digit is determined in the following manner:

- the digits in the even positions of the basic number (counting from the right) are taken at their own decimal value;
- the digits in the odd positions of the basic number (counting from the right) are multiplied by 2;
- the sum formed by the digits in even position and by all the digits which constitute the partial products obtained from the odd positions is then established;
- the unit's digit of this sum is retained;
- the complement required to bring the unit's digit to 10 forms the check-digit; should this units digit be nought, then the check-digit will also be nought.

Examples:

1 —	Let the basic number be	3	3	8	4	4	7	9	6	1	0	0
	Multiplication factor	1	2	1	2	1	2	1	2	1	2	
		6	3	16	4	8	7	18	6	2	0	0

Status: Point in time view as at 31/01/2020.

Changes to legislation: There are currently no known outstanding effects for the Commission Decision of 9 November 2007 adopting a common specification of the national vehicle register provided for under Articles 14(4) and (5) of Directives 96/48/EC and 2001/16/EC (notified under document number C(2007) 5357) (2007/756/EC). (See end of Document for details)

Sum: $6 + 3 + 1 + 6 + 4 + 8 + 7 + 1 + 8 + 6 + 2 + 0 + 0 = 52$

The unit's digit of this sum is 2.

The check-digit number will therefore be 8 and the basic number thus becomes the registration number 33 84 4796 100 – 8.

2 —	Let the basic number be	3	1	5	1	3	3	2	0	1	9	8
	Multiplication factor	1	2	1	2	1	2	1	2	1	2	2
		6	1	10	1	6	3	4	0	2	9	16

Sum: $6 + 1 + 1 + 0 + 1 + 6 + 3 + 4 + 0 + 2 + 9 + 1 + 6 = 40$

The unit's digit of this sum is 0.

The check-digit number will therefore be 0 and the basic number thus becomes the registration number 31 51 3320 198 – 0.

[^{F4}PART 4 —

CODING OF THE COUNTRIES IN WHICH THE VEHICLES ARE REGISTERED (DIGITS 3-4 AND ABBREVIATION)

The Information relating to third countries is given for information purposes only.

Countries	Alphabetical country code ⁽¹⁾	Numerical country code		Countries	Alphabetical country code ⁽¹⁾	Numerical country code
Albania	AL	41		Lithuania	LT	24
Algeria	DZ	92		Luxembourg	L	82
Armenia	AM	58		Former Yugoslav Republic of Macedonia	MK	65
Austria	A	81		Malta	M	
Azerbaijan	AZ	57		Moldova	MD ⁽¹⁾	23
Belarus	BY	21		Monaco	MC	
Belgium	B	88		Mongolia	MGL	31
Bosnia-Herzegovina	BIH	50 and 44 ⁽²⁾		Montenegro	MNE	62
Bulgaria	BG	52		Morocco	MA	93

Status: Point in time view as at 31/01/2020.

Changes to legislation: There are currently no known outstanding effects for the Commission Decision of 9 November 2007 adopting a common specification of the national vehicle register provided for under Articles 14(4) and (5) of Directives 96/48/EC and 2001/16/EC (notified under document number C(2007) 5357) (2007/756/EC). (See end of Document for details)

China	RC	33		Netherlands	NL	84
Croatia	HR	78		North Korea	PRK ⁽¹⁾	30
Cuba	CU ⁽¹⁾	40		Norway	N	76
Cyprus	CY			Poland	PL	51
Czech Republic	CZ	54		Portugal	P	94
Denmark	DK	86		Romania	RO	53
Egypt	ET	90		Russia	RUS	20
Estonia	EST	26		Serbia	SRB	72
Finland	FIN	10		Slovakia	SK	56
France	F	87		Slovenia	SLO	79
Georgia	GE	28		South Korea	ROK	61
Germany	D	80		Spain	E	71
Greece	GR	73		Sweden	S	74
Hungary	H	55		Switzerland	CH	85
Iran	IR	96		Syria	SYR	97
Iraq	IRQ ⁽¹⁾	99		Tajikistan	TJ	66
Ireland	IRL	60		Tunisia	TN	91
Israel	IL	95		Turkey	TR	75
Italy	I	83		Turkmenistan	TM	67
Japan	J	42		Ukraine	UA	22
Kazakhstan	KZ	27		United Kingdom	GB	70
Kyrgyzstan	KS	59		Uzbekistan	UZ	29
Latvia	LV	25		Vietnam	VN ⁽¹⁾	32
Lebanon	RL	98		⁽¹⁾	According to the alphabetical coding system described in Appendix 4 to the 1949 convention and Article 45(4) of the 1968 convention on road traffic.	
				⁽²⁾	Bosnia-Herzegovina uses 2 specific railway codes. A numerical country code 49 is reserved.]	

Status: Point in time view as at 31/01/2020.

Changes to legislation: There are currently no known outstanding effects for the Commission Decision of 9 November 2007 adopting a common specification of the national vehicle register provided for under Articles 14(4) and (5) of Directives 96/48/EC and 2001/16/EC (notified under document number C(2007) 5357) (2007/756/EC). (See end of Document for details)

PART 5

Not used

PART 6 —

INTEROPERABILITY CODES USED FOR WAGONS (DIGITS 1-2)

	2nd digit	1st digit	0	1	2	3	4	5	6	7	8	9	2nd digit	1st digit
			Track Gauge variable	fixed	fixed	variable	fixed	variable	fixed	variable	fixed	variable	Track Gauge variable	
Wagons conform to TSI WAG ^a including section 7.1.2 and all conditions set out in Appendix C	0	with axles to be used	Not to be used	wagons	not to be used ^c							PPV/PPW wagons (variable gauge)	with 0 axles	
	1	with bogies		wagons								PPV/PPW wagons (fixed gauge)	with 1 bogies	
	2	with axles		wagons								PPV/PPW wagons (fixed gauge)	with 2 axles	
Other wagons	3	with bogies											with 3 bogies	
	4	with axles	maintained	Other wagons									Wagons with special numbering for technical characteristics not placed in service inside EU	with 4 axles ^b
	8	with bogies ^b	wagons										with 8 bogies ^b	
	2nd digit	1st digit	0	1	2	3	4	5	6	7	8	9	2nd digit	1st digit

^a Commission Regulation [TSI WAG as adopted after the revision].

^b Fixed or variable gauge.

^c Except for wagons in category I (temperature-controlled wagons), not to be used for new vehicles authorised placed in service.

Status: Point in time view as at 31/01/2020.

Changes to legislation: There are currently no known outstanding effects for the Commission Decision of 9 November 2007 adopting a common specification of the national vehicle register provided for under Articles 14(4) and (5) of Directives 96/48/EC and 2001/16/EC (notified under document number C(2007) 5357) (2007/756/EC). (See end of Document for details)

PART 7 —

INTERNATIONAL TRAFFIC ABILITY CODES USED FOR HAULED PASSENGER VEHICLES (DIGITS 1-2)

2nd digit 1st digit	Domestic traffic and/or COTIF ^a and/or PPV/PPW				Domestic traffic and/or international traffic by special agreement			PPV/PPW		
	0	1	2	3	4	5	6	7	8	9
5	Vehicles for domestic traffic	Fixed-gauge non-air-conditioned vehicles (including car-carrying wagons)	Gauge-adjustable non-conditioned vehicles (1435/1520)	Not to be used	Gauge-adjustable non-air-conditioned vehicles (1435/1668)	Historical vehicles (1668)	Not to be used ^c	Fixed-gauge vehicles	Gauge-adjustable vehicles with change of bogies (1435/1520)	Gauge-adjustable vehicles with gauge-adjustable axles (1435/1520)
6	Service vehicles	Fixed-gauge air-conditioned vehicles	Gauge-adjustable air-conditioned vehicles (1435/1520)	Service vehicles (1520)	Gauge-adjustable air-conditioned vehicles (1435/1668)	Car-carrying wagons (1668)	Not to be used ^c			
7	Air-conditioned and pressure-tight vehicles	Not to be used	Not to be used	Pressure-tight fixed-gauge air-conditioned vehicles	Not to be used	Other vehicles	Not to be used	Not to be used	Not to be used	Not to be used

a Compliance with the applicable TSIs, see appendix P, part 5.

b Including vehicles, which according to existing regulations carry the digits defined in the present table. COTIF: vehicle compliant with COTIF regulation in force at the moment of placing in service

c Excepted for coaches with fixed gauge (56) and adjustable gauge (66) already in service, not to be used for new vehicles

PART 8 —

TYPES OF TRACTIVE ROLLING STOCK AND UNITS IN A TRAIN SET IN FIXED OR PRE-DEFINED FORMATION (DIGITS 1-2)

The first digit is '9'.

Status: Point in time view as at 31/01/2020.

Changes to legislation: There are currently no known outstanding effects for the Commission Decision of 9 November 2007 adopting a common specification of the national vehicle register provided for under Articles 14(4) and (5) of Directives 96/48/EC and 2001/16/EC (notified under document number C(2007) 5357) (2007/756/EC). (See end of Document for details)

If the second digit describes the type of tractive stock, following coding is mandatory:

Code	General vehicle type
0	Miscellaneous
1	Electric locomotive
2	Diesel locomotive
3	Electric multiple-unit set (high speed) [power car or trailer]
4	Electric multiple-unit set (except high speed) [power car or trailer]
5	Diesel multiple-unit set [power car or trailer]
6	Specialised trailer,
7	Electric shunting engine
8	Diesel shunting engine
9	Special vehicle

PART 9 —

STANDARD NUMERICAL MARKING OF WAGONS (DIGITS 5 TO 8)

Part 9 indicates the numerical marking associated to the main technical characteristics of the wagon and it is published on the ERA website (www.era.europa.eu).

An application for a new code is filed with the registering entity (as referred to in Decision 2007/756/EC) and sent to the ERA. A new code can be used only after publication by the ERA.

PART 10 —

CODES FOR THE TECHNICAL CHARACTERISTICS OF THE HAULED PASSENGER STOCK (DIGITS 5-6)

Part 10 is published on the ERA website (www.era.europa.eu).

An application for a new code is filed with the registering entity (as referred to in Decision 2007/756/EC) and sent to the ERA. A new code can be used only after publication by the ERA.

PART 11 —

CODES FOR THE TECHNICAL CHARACTERISTICS OF THE SPECIAL VEHICLES (DIGIT 6 TO 8)

Part 11 is published on the ERA website (www.era.europa.eu).

An application for a new code is filed with the registering entity (as referred to in Decision 2007/756/EC) and sent to the ERA. A new code can be used only after publication by the ERA.

Status: Point in time view as at 31/01/2020.

Changes to legislation: There are currently no known outstanding effects for the Commission Decision of 9 November 2007 adopting a common specification of the national vehicle register provided for under Articles 14(4) and (5) of Directives 96/48/EC and 2001/16/EC (notified under document number C(2007) 5357) (2007/756/EC). (See end of Document for details)

PART 12 —

LETTER MARKING FOR WAGONS EXCLUDING ARTICULATED AND MULTIPLE WAGONS

Part 12 is published on the ERA website (www.era.europa.eu).

An application for a new code is filed with the registering entity (as referred to in Decision 2007/756/EC) and sent to the ERA. A new code can be used only after publication by the ERA.

PART 13 —

LETTER MARKING FOR HAULED PASSENGER STOCK

Part 13 is published on the ERA website (www.era.europa.eu).

An application for a new code is filed with the registering entity (as referred to in Decision 2007/756/EC) and sent to the ERA. A new code can be used only after publication by the ERA.]]

Status: Point in time view as at 31/01/2020.

Changes to legislation: There are currently no known outstanding effects for the Commission Decision of 9 November 2007 adopting a common specification of the national vehicle register provided for under Articles 14(4) and (5) of Directives 96/48/EC and 2001/16/EC (notified under document number C(2007) 5357) (2007/756/EC). (See end of Document for details)

- (1) OJ L 235, 17.9.1996, p. 6. Directive as last amended by Commission Directive 2007/32/EC (OJ L 141, 2.6.2007, p. 63).
- (2) OJ L 110, 20.4.2001, p. 1. Directive as last amended by Commission Directive 2007/32/EC).
- (3) OJ L 164, 30.4.2004, p. 1, as corrected by OJ L 220, 21.6.2004, p. 3.
- (4) [^{F2}[^{F4}Directive (EU) 2016/797 of the European Parliament and of the Council of 11 May 2016 on the interoperability of the rail system within the European Union (OJ L 138, 26.5.2016, p. 44)]]
- (5) [^{F2}[^{F5}Directive 2008/57/EC of the European Parliament and of the Council of 17 June 2008 on the interoperability of the rail system within the Community (OJ L 191, 18.7.2008, p. 1).]]
- (6) [^{F2}However, any new vehicles placed in service for AAE, BLS, FNME and GySEV/ROeEE are to be given the standard country code.]
- (7) [^{F2}OJ L 235, 17.9.1996, p. 6.]
- (8) [^{F2}OJ L 110, 20.4.2001, p. 1.]
- (9) [^{F2}OJ L 359, 18.12.2006, p. 1.]
- (10) [^{F2}OJ L 84, 26.3.2008, p. 1.]
- (11) [^{F2}OJ L 280, 26.10.2010, p. 29.]
- (12) [^{F2}[^{F1}For special vehicles, the number has to be unique in a given country with the first digit and the 5 last digits of the technical characteristics and serial number.]]
- (13) [^{F2}[^{F1}[^{F4}For NMBS/SNCB, the use of an encircled single letter B can be continued.]]]
- (14) [^{F2}[^{F1}Diacritical marks are ‘accent-signs’, such as in Å, Ç, Ö, Ć, Ž, Å etc. Special letters such as Ø and Æ will be represented by a single letter; in tests for uniqueness Ø is treated as O and Æ as A.]]

Textual Amendments

- F1** Inserted by Commission Decision of 14 November 2012 concerning the technical specification for interoperability relating to the ‘operation and traffic management’ subsystem of the rail system in the European Union and amending Decision 2007/756/EC (notified under document C(2012) 8075) (Text with EEA relevance) (2012/757/EU).
- F2** Substituted by Commission Decision of 10 February 2011 amending Decision 2007/756/EC adopting a common specification of the national vehicle register (notified under document C(2011) 665) (Text with EEA relevance) (2011/107/EU).
- F4** Substituted by Commission Implementing Decision (EU) 2018/1614 of 25 October 2018 laying down specifications for the vehicle registers referred to in Article 47 of Directive (EU) 2016/797 of the European Parliament and of the Council and amending and repealing Commission Decision 2007/756/EC (Text with EEA relevance).
- F5** Inserted by Commission Implementing Decision (EU) 2018/1614 of 25 October 2018 laying down specifications for the vehicle registers referred to in Article 47 of Directive (EU) 2016/797 of the European Parliament and of the Council and amending and repealing Commission Decision 2007/756/EC (Text with EEA relevance).

Status:

Point in time view as at 31/01/2020.

Changes to legislation:

There are currently no known outstanding effects for the Commission Decision of 9 November 2007 adopting a common specification of the national vehicle register provided for under Articles 14(4) and (5) of Directives 96/48/EC and 2001/16/EC (notified under document number C(2007) 5357) (2007/756/EC).