

This document is meant purely as a documentation tool and the institutions do not assume any liability for its contents

► **B**

**COMMISSION DECISION**

**of 26 April 2011**

**concerning a technical specification for interoperability relating to the rolling stock subsystem —  
‘Locomotives and passenger rolling stock’ of the trans-European conventional rail system**

*(notified under document C(2011) 2737)*

**(Text with EEA relevance)**

(2011/291/EU)

(OJ L 139, 26.5.2011, p. 1)

Amended by:

		Official Journal		
		No	page	date
► <b><u>M1</u></b>	Commission Decision 2012/88/EU of 25 January 2012	L 51	1	23.2.2012

**COMMISSION DECISION****of 26 April 2011****concerning a technical specification for interoperability relating to the rolling stock subsystem — ‘Locomotives and passenger rolling stock’ of the trans-European conventional rail system***(notified under document C(2011) 2737)***(Text with EEA relevance)****(2011/291/EU)**

THE EUROPEAN COMMISSION,

Having regard to the Treaty on the Functioning of the European Union,

Having regard to Directive 2008/57/EC of the European Parliament and the Council of 17 June 2008 on the interoperability of the rail system within the Community <sup>(1)</sup>, and in particular Article 6(1) thereof,

Whereas:

- (1) In accordance with Article 2(e) and Annex II of Directive 2008/57/EC, the rail system is subdivided into structural and functional subsystems, including a rolling stock subsystem.
- (2) By Decision C(2006) 124 final of 9 February 2007, the Commission gave a mandate to the European Railway Agency (hereinafter ‘the Agency’) to develop technical specifications for interoperability (TSIs) under Directive 2001/16/EC of the European Parliament and of the Council of 19 March 2001 on the interoperability of the trans-European conventional rail system <sup>(2)</sup>. Under the terms of that mandate, the Agency was requested to draw up the draft TSIs related to passenger carriages and locomotives and traction units, related to the rolling stock subsystem of the conventional rail system.
- (3) Technical specifications for interoperability (TSIs) are specifications adopted in accordance with Directive 2008/57/EC. The TSI to be set up by this Decision should cover the rolling stock subsystem in order to meet the essential requirements and ensure the interoperability of the rail system.
- (4) The TSI on rolling stock to be set up by this Decision does not fully deal with all essential requirements. In accordance with Article 5(6) of Directive 2008/57/EC, technical aspects which are not covered should be identified as open points.
- (5) The TSI on rolling stock should refer to Commission Decision 2010/713/EU of 9 November 2010 on modules for the procedures for assessment of conformity, suitability for use and EC verification to be used in the technical specifications for interoperability adopted under Directive 2008/57/EC of the European Parliament and of the Council <sup>(3)</sup>.

<sup>(1)</sup> OJ L 191, 18.7.2008, p. 1.

<sup>(2)</sup> OJ L 110, 20.4.2001, p. 1.

<sup>(3)</sup> OJ L 319, 4.12.2010, p. 1.

**▼B**

- (6) In accordance with Article 17(3) of Directive 2008/57/EC, Member States are to notify to the Commission and other Member States the technical rules, the conformity assessment and verification procedures to be used for the specific cases, as well as the bodies responsible for carrying out these procedures.
- (7) Commission Decision 2008/163/EC of 20 December 2007 concerning the technical specification of interoperability relating to 'safety in railway tunnels' in the trans-European conventional and high-speed rail system<sup>(1)</sup>, includes in its scope some requirements of the rolling stock running in the conventional rail system. Therefore Decision 2008/163/EC should be amended
- (8) The TSI on rolling stock should be without prejudice to the provisions of other relevant TSIs which may be applicable to rolling stock subsystems.
- (9) The TSI on rolling stock should not impose the use of specific technologies or technical solutions except where this is strictly necessary for the interoperability of the rail system within the European Union.
- (10) In accordance with Article 11(5) of Directive 2008/57/EC, the TSI on rolling stock should allow, for a limited period of time, for interoperability constituents to be incorporated into subsystems without certification if certain conditions are met.
- (11) To continue to encourage innovation and to take into account the experience acquired, this Decision should be subject to periodic revision.
- (12) The provisions of this Decision are in conformity with the opinion of the Committee set up by Article 21 of Council Directive 96/48/EC<sup>(2)</sup>,

HAS ADOPTED THIS DECISION:

*Article 1*

The technical specification for interoperability (TSI) relating to the rolling stock subsystem, 'Locomotive and passenger rolling stock', of the trans-European conventional railway system as set out in the Annex is hereby adopted.

*Article 2*

1. The TSI set out in the Annex shall apply to all new rolling stock of the trans-European conventional rail system as defined in Annex I to Directive 2008/57/EC. The technical and geographical scope of this Decision is set out in Sections 1.1 and 1.2 of the Annex.

The TSI set out in the Annex shall also apply to existing rolling stock when it is subject to renewal or upgrading in accordance with Article 20 of Directive 2008/57/EC.

<sup>(1)</sup> OJ L 64, 7.3.2008, p. 1.

<sup>(2)</sup> OJ L 235, 17.9.1996, p. 6.

**▼B**

2. Until 1 June 2017, the application of this TSI shall not be compulsory for the following rolling stock:

- (a) projects at an advanced stage of development, as referred to in clause 7.1.1.2.2 of the TSI set out in the Annex;
- (b) contracts in course of performance, as referred to in clause 7.1.1.2.3 of the TSI set out in the Annex;
- (c) rolling stock of an existing design, as referred to in clause 7.1.1.2.4 of the TSI set out in the Annex.

*Article 3*

1. With regard to those issues classified as open points set out in the TSI set out in the Annex, the conditions to be complied with for the verification of the interoperability pursuant to Article 17(2) of Directive 2008/57/EC shall be the applicable technical rules in use in the Member State which authorises the placing in service of the subsystems covered by this Decision.

2. Each Member State shall notify to the other Member States and to the Commission within six months of the notification of this Decision:

- (a) the applicable technical rules referred to in paragraph 1;
- (b) the conformity assessment and checking procedures to be applied with regard to the application of the technical rules referred to in paragraph 1;
- (c) the bodies it appoints for carrying out the conformity assessment and checking procedures of the open points referred to in paragraph 1.

3. With regard to the national rules applicable to vehicles categorised for national use in section 4.2.3.5.2.2, paragraph 2 of this Article also applies.

*Article 4*

1. With regard to those issues classified as specific cases set out in Section 7 of the TSI set out in the Annex, the conditions to be complied with for the verification of the interoperability pursuant to Article 17(2) of Directive 2008/57/EC shall be the applicable technical rules in use in the Member State which authorises the placing in service of the subsystems covered by this Decision.

2. Each Member State shall notify to the other Member States and to the Commission within six months of the notification of this Decision:

- (a) the applicable technical rules referred to in paragraph 1;
- (b) the conformity assessment and checking procedures to be applied with regard to the application of the technical rules referred to in paragraph 1;
- (c) the bodies it appoints for carrying out the conformity assessment and checking procedures of the specific cases referred to in paragraph 1.

**▼B***Article 5*

The procedures for assessment of conformity, suitability for use and EC verification set out in Section 6 of the TSI set out in the Annex shall be based on the modules defined in Decision 2010/713/EU.

*Article 6*

1. An EC certificate of verification for a subsystem that contains interoperability constituents not holding an EC declaration of conformity or suitability for use may be issued during a transition period of six years from the date of application of this Decision, on the condition that the provisions set out in Section 6.3 of the Annex are met.
2. The production or upgrade/renewal of the subsystem with use of the non-certified interoperability constituents must be completed within the transition period, including the placing in service.
3. During the transition period Member States shall ensure that:
  - (a) the reasons for non-certification of the interoperability constituents are properly identified in the verification procedure referred to in paragraph 1;
  - (b) the details of the non-certified interoperability constituents and the reasons for non-certification, including the application of national rules notified under Article 17 of Directive 2008/57/EC, are included by the national safety authorities in their annual report referred to in Article 18 of Directive 2004/49/EC of the European Parliament and of the Council <sup>(1)</sup>.
4. After the transition period and with the exceptions allowed under Section 6.3.3 of the Annex on maintenance, interoperability constituents shall be covered by the required EC declaration of conformity and/or suitability for use before being incorporated into the subsystem.

*Article 7*

With regard to the rolling stock concerned by projects at advanced stage of development, each Member State shall communicate to the Commission within one year of entry into force of this Decision a list of projects that are taking place within its territory and are at an advanced stage of development.

*Article 8***Amendments to Decision 2008/163/EC**

Decision 2008/163/EC is amended as follows:

1. the following text is inserted after the second paragraph of point 4.2.5.1 Material properties for rolling stock:

‘In addition, the requirements of clause 4.2.10.2 (Material requirements) of the CR LOC & PAS TSI shall apply to CR rolling stock.’;

<sup>(1)</sup> OJ L 164, 30.4.2004, p. 44.

**▼B**

2. point 4.2.5.4 is replaced by the following:

‘4.2.5.4. *Fire barriers for passenger rolling stock*

- The requirements of clause 4.2.7.2.3.3 (Fire resistance) of the high-speed RST TSI apply to HS rolling stock.
- The requirements of clause 4.2.7.2.3.3 (Fire resistance) of the high-speed RST TSI and the requirements of clause 4.2.10.5 (Fire barriers) of the conventional LOC & PAS TSI apply to CR rolling stock.’;

3. point 4.2.5.7 is replaced by the following:

‘4.2.5.7. *Communication means on trains*

- The requirements of clause 4.2.5.1 (Public address system) of the high-speed RST TSI apply to HS rolling stock.
- The requirements of clause 4.2.5.2 (Public address system: audible communication system) of the conventional LOC & PAS TSI apply to CR rolling stock.’;

4. point 4.2.5.8 is replaced by the following:

‘4.2.5.8. *Emergency brake override*

- The requirements in clause 4.2.5.3 (Passenger alarm) of the high-speed RST TSI apply to HS rolling stock.
- The requirements in clause 4.2.5.3 (Passenger alarm: functional requirements) of the conventional LOC & PAS TSI apply to CR rolling stock.’;

5. point 4.2.5.11.1 is replaced by the following:

‘4.2.5.11.1. *Passengers’ emergency exits*

- The requirements in clause 4.2.7.1.1 (Passengers’ emergency exits) of the high-speed RST TSI apply to HS rolling stock.
- The requirements in clause 4.2.10.4 (Passenger evacuation) of the conventional LOC & PAS TSI apply to CR rolling stock.’.

*Article 9*

This Decision shall apply from 1 June 2011.

*Article 10*

This Decision is addressed to the Member States.



## ANNEX

**DIRECTIVE 2008/57/EC ON THE INTEROPERABILITY OF THE RAIL SYSTEM  
WITHIN THE COMMUNITY**

TECHNICAL SPECIFICATION FOR INTEROPERABILITY

‘Rolling stock’ subsystem for conventional rail ‘Locomotives and passenger rolling stock’

1.	INTRODUCTION .....
1.1.	Technical scope .....
1.2.	Geographical scope .....
1.3.	Content of this TSI .....
1.4.	Referenced documents .....
2.	ROLLING STOCK SUBSYSTEM AND FUNCTIONS .....
2.1.	The rolling stock subsystem as part of the conventional rail system .....
2.2.	Definitions related to rolling stock .....
2.3.	Rolling stock in the scope of this TSI .....
3.	ESSENTIAL REQUIREMENTS .....
3.1.	General .....
3.2.	Elements of the rolling stock subsystem corresponding to the essential requirements .....
3.3.	Essential requirements not covered by this TSI .....
3.3.1.	General requirements, requirements related to maintenance and operation ...
3.3.2.	Requirements specific to other subsystems .....
4.	CHARACTERISATION OF THE ROLLING STOCK SUBSYSTEM .....
4.1.	Introduction .....
4.1.1.	General .....
4.1.2.	Description of the rolling stock subject to the application of this TSI .....
4.1.3.	Main categorisation of the rolling stock for application of TSI requirements
4.1.4.	Categorisation of the rolling stock for fire safety .....
4.2.	Functional and technical specification of the subsystem .....
4.2.1.	General .....
4.2.1.1.	Breakdown .....
4.2.1.2.	Open points .....
4.2.1.3.	Safety aspects .....
4.2.2.	Structure and mechanical parts .....
4.2.2.1.	General .....
4.2.2.2.	Mechanical interfaces .....
4.2.2.2.1.	General and definitions .....
4.2.2.2.2.	Inner coupling .....
4.2.2.2.3.	End coupling .....
4.2.2.2.4.	Rescue coupling .....
4.2.2.2.5.	Staff access for coupling and uncoupling .....
4.2.2.3.	Gangways .....

**▼B**

4.2.2.4.	Strength of vehicle structure .....
4.2.2.5.	Passive safety .....
4.2.2.6.	Lifting and jacking .....
4.2.2.7.	Fixing of devices to car body structure .....
4.2.2.8.	Staff and freight access doors .....
4.2.2.9.	Mechanical characteristics of glass (other than windscreens) .....
4.2.2.10.	Load conditions and weighted mass .....
4.2.3.	Track interaction and gauging .....
4.2.3.1.	Gauging .....
4.2.3.2.	Axle load and wheel load .....
4.2.3.2.1.	Axle load parameter .....
4.2.3.2.2.	Wheel load .....
4.2.3.3.	Rolling stock parameters which influence ground based systems .....
4.2.3.3.1.	Rolling Stock characteristics for the compatibility with train detection systems
4.2.3.3.1.1.	Rolling stock characteristics for compatibility with train detection system based on track circuits .....
4.2.3.3.1.2.	Rolling stock characteristics for compatibility with train detection system based on axle counters .....
4.2.3.3.1.3.	Rolling stock characteristics for compatibility with loop equipment .....
4.2.3.3.2.	Axle bearing condition monitoring .....
4.2.3.4.	Rolling stock dynamic behaviour .....
4.2.3.4.1.	Safety against derailment running on twisted track .....
4.2.3.4.2.	Running dynamic behaviour .....
4.2.3.4.2.1.	Limit values for running safety .....
4.2.3.4.2.2.	Track loading limit values .....
4.2.3.4.3.	Equivalent conicity .....
4.2.3.4.3.1.	Design values for new wheel profiles .....
4.2.3.4.3.2.	In-service values of wheelset equivalent conicity .....
4.2.3.5.	Running gear .....
4.2.3.5.1.	Structural design of bogie frame .....
4.2.3.5.2.	Wheelsets .....
4.2.3.5.2.1.	Mechanical and geometric characteristics of wheelsets .....
4.2.3.5.2.2.	Mechanical and geometrical characteristics of wheels .....
4.2.3.5.2.3.	Variable gauge wheelsets .....
4.2.3.6.	Minimum curve radius .....
4.2.3.7.	Life guards .....
4.2.4.	Braking .....
4.2.4.1.	General .....
4.2.4.2.	Main functional and safety requirements .....
4.2.4.2.1.	Functional requirements .....



**▼B**

4.2.4.2.2.	Safety requirements .....
4.2.4.3.	Type of brake system .....
4.2.4.4.	Brake command .....
4.2.4.4.1.	Emergency braking command .....
4.2.4.4.2.	Service braking command .....
4.2.4.4.3.	Direct braking command .....
4.2.4.4.4.	Dynamic braking command .....
4.2.4.4.5.	Parking braking command .....
4.2.4.5.	Braking performance .....
4.2.4.5.1.	General requirements .....
4.2.4.5.2.	Emergency braking .....
4.2.4.5.3.	Service braking .....
4.2.4.5.4.	Calculations related to thermal capacity .....
4.2.4.5.5.	Parking brake .....
4.2.4.6.	Wheel rail adhesion profile — Wheel slide protection system .....
4.2.4.6.1.	Limit of wheel rail adhesion profile .....
4.2.4.6.2.	Wheel slide protection system .....
4.2.4.7.	Dynamic brake — Braking system linked to traction system .....
4.2.4.8.	Braking system independent of adhesion conditions .....
4.2.4.8.1.	General .....
4.2.4.8.2.	Magnetic track brake .....
4.2.4.8.3.	Eddy current track brake .....
4.2.4.9.	Brake state and fault indication .....
4.2.4.10.	Brake requirements for rescue purposes .....
4.2.5.	Passenger related items .....
4.2.5.1.	Sanitary systems .....
4.2.5.2.	Public address system: audible communication system .....
4.2.5.3.	Passenger alarm: functional requirements .....
4.2.5.4.	Safety instructions to passengers — Signs .....
4.2.5.5.	Communication devices for passengers .....
4.2.5.6.	Exterior doors: passenger access to and egress from rolling stock .....
4.2.5.7.	Exterior door system construction .....
4.2.5.8.	Inter-unit doors .....
4.2.5.9.	Internal air quality .....
4.2.5.10.	Body side windows .....
4.2.6.	Environmental conditions and aerodynamic effects .....
4.2.6.1.	Environmental conditions .....
4.2.6.1.1.	Altitude .....

**▼ B**

4.2.6.1.2.	Temperature .....
4.2.6.1.3.	Humidity .....
4.2.6.1.4.	Rain .....
4.2.6.1.5.	Snow, ice and hail .....
4.2.6.1.6.	Solar radiation .....
4.2.6.1.7.	Resistance to pollution .....
4.2.6.2.	Aerodynamic effects .....
4.2.6.2.1.	Slipstream effects on passengers on platform .....
4.2.6.2.2.	Slipstream effects on workers at the track side .....
4.2.6.2.3.	Head pressure pulse .....
4.2.6.2.4.	Maximum pressure variations in tunnels .....
4.2.6.2.5.	Cross wind .....
4.2.7.	External lights and visible and audible warning devices .....
4.2.7.1.	External lights .....
4.2.7.1.1.	Head lights .....
4.2.7.1.2.	Marker lights .....
4.2.7.1.3.	Tail lights .....
4.2.7.1.4.	Lamp controls .....
4.2.7.2.	Horn (audible warning device) .....
4.2.7.2.1.	General .....
4.2.7.2.2.	Warning horn sound pressure levels .....
4.2.7.2.3.	Protection .....
4.2.7.2.4.	Horn control .....
4.2.8.	Traction and electrical equipment .....
4.2.8.1.	Traction performance .....
4.2.8.1.1.	General .....
4.2.8.1.2.	Requirements on performance .....
4.2.8.2.	Power supply .....
4.2.8.2.1.	General .....
4.2.8.2.2.	Operation within range of voltages and frequencies .....
4.2.8.2.3.	Regenerative brake with energy to the overhead contact line .....
4.2.8.2.4.	Maximum power and current from the overhead contact line .....
4.2.8.2.5.	Maximum current at standstill for DC systems .....
4.2.8.2.6.	Power factor .....
4.2.8.2.7.	System energy disturbances for ac systems .....
4.2.8.2.8.	Energy consumption measuring function .....
4.2.8.2.9.	Requirements linked to pantograph .....
4.2.8.2.9.1.	Working range in height of pantograph .....
4.2.8.2.9.1.1.	Height of interaction with contact wires (RST level) .....
4.2.8.2.9.1.2.	Working range in height of pantograph (IC level) .....
4.2.8.2.9.2.	Pantograph head geometry (IC level) .....
4.2.8.2.9.2.1.	Pantograph head geometry type 1 600 mm .....

**▼ B**

4.2.8.2.9.2.2.	Pantograph head geometry type 1 950 mm .....
4.2.8.2.9.3.	Pantograph current capacity (IC level) .....
4.2.8.2.9.4.	Contact strip (IC level) .....
4.2.8.2.9.4.1.	Contact strip geometry .....
4.2.8.2.9.4.2.	Contact strip material .....
4.2.8.2.9.4.3.	Contact strip characteristics .....
4.2.8.2.9.5.	Pantograph static contact force (IC level) .....
4.2.8.2.9.6.	Pantograph contact force and dynamic behaviour .....
4.2.8.2.9.7.	Arrangement of pantographs (RST level) .....
4.2.8.2.9.8.	Running through phase or system separation sections (RST level) .....
4.2.8.2.9.9.	Insulation of pantograph from the vehicle (RST level) .....
4.2.8.2.9.10.	Pantograph lowering (RST level) .....
4.2.8.2.10.	Electrical protection of the train .....
4.2.8.3.	Diesel and other thermal traction system .....
4.2.8.4.	Protection against electrical hazards .....
4.2.9.	Driver's cab and driver-machine interface .....
4.2.9.1.	Driver's cab .....
4.2.9.1.1.	General .....
4.2.9.1.2.	Access and egress .....
4.2.9.1.2.1.	Access and egress in operating conditions .....
4.2.9.1.2.2.	Driver's cab emergency exit .....
4.2.9.1.3.	External visibility .....
4.2.9.1.3.1.	Front visibility .....
4.2.9.1.3.2.	Rear and side view .....
4.2.9.1.4.	Interior layout .....
4.2.9.1.5.	Driver's seat .....
4.2.9.1.6.	Driver's desk — Ergonomics .....
4.2.9.1.7.	Climate control and air quality .....
4.2.9.1.8.	Internal lighting .....
4.2.9.2.	Windscreen .....
4.2.9.2.1.	Mechanical characteristics .....
4.2.9.2.2.	Optical characteristics .....
4.2.9.2.3.	Equipment .....
4.2.9.3.	Driver machine interface .....
4.2.9.3.1.	Driver's activity control function .....
4.2.9.3.2.	Speed indication .....
4.2.9.3.3.	Driver display unit and screens .....
4.2.9.3.4.	Controls and indicators .....
4.2.9.3.5.	Labelling .....

**▼B**

4.2.9.3.6.	Remote control function from the ground .....
4.2.9.4.	Onboard tools and portable equipment .....
4.2.9.5.	Storage facility for staff personal effects .....
4.2.9.6.	Recording device .....
4.2.10.	Fire safety and evacuation .....
4.2.10.1.	General and categorisation .....
4.2.10.1.1.	Requirements applicable to all units, except freight locomotives and OTMs:
4.2.10.1.2.	Requirements applicable to freight locomotives and OTMs: .....
4.2.10.1.3.	Requirements specified in the SRT TSI .....
4.2.10.2.	Material requirements .....
4.2.10.3.	Specific measures for flammable liquids .....
4.2.10.4.	Passenger evacuation .....
4.2.10.5.	Fire barriers .....
4.2.11.	Servicing .....
4.2.11.1.	General .....
4.2.11.2.	Train exterior cleaning .....
4.2.11.2.1.	Cleaning of driver's cab windscreen .....
4.2.11.2.2.	Exterior cleaning through a washing plant .....
4.2.11.3.	Toilet discharge system .....
4.2.11.4.	Water refilling equipment .....
4.2.11.5.	Interface for water refilling .....
4.2.11.6.	Special requirements for stabling of trains .....
4.2.11.7.	Refuelling equipment .....
4.2.12.	Documentation for operation and maintenance .....
4.2.12.1.	General .....
4.2.12.2.	General documentation .....
4.2.12.3.	Documentation related to maintenance .....
4.2.12.3.1.	The maintenance design justification file .....
4.2.12.3.2.	The maintenance description file .....
4.2.12.4.	Operating documentation .....
4.2.12.5.	Lifting diagram and instructions .....
4.2.12.6.	Rescue related descriptions .....
4.3.	Functional and technical specification of the interfaces .....
4.3.1.	Interface with energy subsystem .....
4.3.2.	Interface with infrastructure subsystem .....
4.3.3.	Interface with operation subsystem .....
4.3.4.	Interface with the control, command and signalling subsystem .....
4.3.5.	Interface with the telematic application for passengers subsystem .....
4.4.	Operating rules .....
4.5.	Maintenance rules .....

**▼B**

4.6.	Professional competencies
4.7.	Health and safety conditions
4.8.	European register of authorised types of vehicles
5.	INTEROPERABILITY CONSTITUENTS
5.1.	Definition
5.2.	Innovative solution
5.3.	Interoperability constituent specification
5.3.1.	Rescue couplers
5.3.2.	Wheels
5.3.3.	WSP (wheel slide protection system)
5.3.4.	Head lights
5.3.5.	Marker lights
5.3.6.	Tail lights
5.3.7.	Horns
5.3.8.	Pantograph
5.3.8.1.	Contact strips
5.3.9.	Main circuit breaker
5.3.10.	Toilet discharge connection
5.3.11.	Inlet connection for water tanks
6.	ASSESSMENT OF CONFORMITY OR SUITABILITY FOR USE
6.1.	Interoperability constituents
6.1.1.	Conformity assessment
6.1.2.	Conformity assessment procedures
6.1.2.1.	Conformity assessment modules
6.1.2.2.	Particular assessment procedures for interoperability constituents
6.1.2.2.1.	Wheel slide protection system (clause 5.3.3)
6.1.2.2.2.	Head lights (clause 5.3.4)
6.1.2.2.3.	Marker lights (clause 5.3.5)
6.1.2.2.4.	Tail lights (clause 5.3.6)
6.1.2.2.5.	Horn (clause 5.3.7)
6.1.2.2.6.	Pantograph (clause 5.3.8)
6.1.2.2.7.	Contact strips (clause 5.3.8.1)
6.1.2.3.	Project phases where assessment is required
6.1.3.	Innovative solutions
6.1.4.	Constituent requiring EC declarations against the HS RST TSI and against TSI
6.1.5.	Assessment of suitability for use
6.2.	Rolling stock subsystem
6.2.1.	EC verification (general)
6.2.2.	Conformity assessment procedures (modules)
6.2.2.1.	Conformity assessment modules
6.2.2.2.	Particular assessment procedures for subsystems

**▼B**

6.2.2.2.1.	Load conditions and weighted mass (clause 4.2.2.10) . . . . .
6.2.2.2.2.	Gauging (clause 4.2.3.1) . . . . .
6.2.2.2.3.	Wheel load (clause 4.2.3.2.2) . . . . .
6.2.2.2.4.	Braking — safety requirements (clause 4.2.4.2.2) . . . . .
6.2.2.2.5.	Emergency braking (clause 4.2.4.5.2) . . . . .
6.2.2.2.6.	Service braking (clause 4.2.4.5.3) . . . . .
6.2.2.2.7.	Wheel slide protection system (clause 4.2.4.6.2) . . . . .
6.2.2.2.8.	Sanitary systems (clause 4.2.5.1) . . . . .
6.2.2.2.9.	Internal air quality (clause 4.2.5.9 and clause 4.2.9.1.7) . . . . .
6.2.2.2.10.	Slipstream effects on passengers on platform (clause 4.2.6.2.1) . . . . .
6.2.2.2.11.	Slipstream effects on workers at track side (clause 4.2.6.2.2) . . . . .
6.2.2.2.12.	Head pressure pulse (clause 4.2.6.2.3) . . . . .
6.2.2.2.13.	Maximum power and current from the overhead contact line (clause 4.2.8.2.4)
6.2.2.2.14.	Power factor (clause 4.2.8.2.6) . . . . .
6.2.2.2.15.	Current collection dynamic behaviour (clause 4.2.8.2.9.6) . . . . .
6.2.2.2.16.	Arrangement of pantographs (clause 4.2.8.2.9.7) . . . . .
6.2.2.2.17.	Windscreen (clause 4.2.9.2) . . . . .
6.2.2.2.18.	Fire barriers (clause 4.2.10.5) . . . . .
6.2.2.3.	Project phases where assessment is required . . . . .
6.2.3.	Innovative solutions . . . . .
6.2.4.	Assessment of documentation requested for operation and maintenance . . . . .
6.2.5.	Units requiring EC certificates against the HS RST TSI and against this TSI
6.2.6.	Assessment of units intended to be used in general operation . . . . .
6.2.7.	Assessment of units intended to be used in pre-defined formation(s) . . . . .
6.2.8.	Particular case: Assessment of units intended to be included in an existing fixed formation . . . . .
6.2.8.1.	Context . . . . .
6.2.8.2.	Case of a TSI compliant fixed formation . . . . .
6.2.8.3.	Case of a non-TSI compliant fixed formation . . . . .
6.3.	Subsystem containing interoperability constituents not holding an EC declaration . . . . .
6.3.1.	Conditions . . . . .
6.3.2.	Documentation . . . . .
6.3.3.	Maintenance of the subsystems certified according to clause 6.3.1 . . . . .
7.	IMPLEMENTATION . . . . .
7.1.	General rules for implementation . . . . .
7.1.1.	Application to newly built rolling stock . . . . .

**▼ B**

7.1.1.1.	General
7.1.1.2.	Transition period
7.1.1.2.1.	Introduction
7.1.1.2.2.	Projects at advanced stage of development
7.1.1.2.3.	Contracts in course of performance
7.1.1.2.4.	Rolling stock of an existing design
7.1.1.3.	Application to OTMs
7.1.1.4.	Interface with implementation of other TSIs
7.1.2.	Renewal and upgrade of existing rolling stock
7.1.2.1.	Introduction
7.1.2.2.	Renewal
7.1.2.3.	Upgrade
7.1.3.	Rules related to the type or design examination certificates
7.1.3.1.	Rolling stock subsystem
7.1.3.2.	Interoperability constituents
7.2.	Compatibility with other subsystems
7.3.	Specific cases
7.3.1.	General
7.3.2.	List of specific cases
7.3.2.1.	General specific cases
7.3.2.2.	Mechanical interfaces — End coupling (4.2.2.2.3)
7.3.2.3.	Gauging (4.2.3.1)
7.3.2.4.	Axle bearing condition monitoring (4.2.3.3.2)
7.3.2.5.	Rolling stock dynamic behaviour (4.2.3.4)
7.3.2.6.	Track loading limit values (4.2.3.4.2.2)
7.3.2.7.	Design values for new wheel profiles (4.2.3.4.3.1)
7.3.2.8.	Wheelsets (4.2.3.5.2)
7.3.2.9.	Geometrical characteristics of wheels (4.2.3.5.2.2)
7.3.2.10.	Slipstream effects on passengers on platforms (4.2.6.2.1)
7.3.2.11.	Head pressure pulse (4.2.6.2.3)
7.3.2.12.	Warning horn sound pressure levels (4.2.7.2.2)
7.3.2.13.	Power supply — General (4.2.8.2.1)
7.3.2.14.	Operation within range of voltages and frequencies (4.2.8.2.2)
7.3.2.15.	Working range in height of pantograph (4.2.8.2.9.1)
7.3.2.16.	Pantograph head geometry (4.2.8.2.9.2)
7.3.2.17.	Pantograph contact force and dynamic behaviour (4.2.8.2.9.6)
7.3.2.18.	Front visibility (4.2.9.1.3.1)
7.3.2.19.	Driver's desk — Ergonomics (4.2.9.1.6)
7.3.2.20.	Material requirements (4.2.10.2)
7.3.2.21.	Interfaces for water refilling (4.2.11.5) and toilet discharge (4.2.11.3)
7.3.2.22.	Special requirement for stabling of trains (4.2.11.6)

**▼B**

7.3.2.23.	Refuelling equipment (4.2.11.7) . . . . .
7.4.	Specific environmental conditions . . . . .
7.5.	Aspects that have to be considered in the revision process or in other activities of the Agency . . . . .
7.5.1.	Aspects related to a basic parameter in this TSI . . . . .
7.5.1.1.	Axle load parameter (clause 4.2.3.2.1) . . . . .
7.5.1.2.	Track loading limit value (clause 4.2.3.4.2.2) . . . . .
7.5.1.3.	Aerodynamic effects (clause 4.2.6.2) . . . . .
7.5.2.	Aspects not related to a basic parameter in this TSI but are subject to research projects . . . . .
7.5.2.1.	Additional requirements for security reasons . . . . .
7.5.3.	Aspects relevant for the EU railway system but out of the scope of TSIs . . . . .
7.5.3.1.	Track interaction (clause 4.2.3) — Flange or rail lubrication . . . . .
ANNEX A:	BUFFERS AND SCREW COUPLING SYSTEM . . . . .
A.1.	Buffers . . . . .
A.2.	Screw coupling . . . . .
A.3.	Interaction of draw- and buffing-gear . . . . .
ANNEX B:	LIFTING AND JACKING POINTS . . . . .
B.1.	Definitions . . . . .
B.1.1.	Re-railing . . . . .
B.1.2.	Recovery . . . . .
B.1.3.	Jacking and lifting points . . . . .
B.2.	Impact of re-railing on the design of rolling stock . . . . .
B.3.	Location of jacking points on the structures of vehicles . . . . .
B.4.	Geometry of jacking/lifting points . . . . .
B.4.1.	Permanent built-in jacking/lifting points . . . . .
B.4.2.	Removable jacking/lifting points . . . . .
B.5.	Securing running gears onto the underframe . . . . .
B.6.	Marking of rescue jacking (resp. lifting) points . . . . .
B.7.	Jacking and lifting instructions . . . . .
ANNEX C:	SPECIAL PROVISIONS FOR MOBILE RAILWAY INFRASTRUCTURE CONSTRUCTION AND MAINTENANCE EQUIPMENT . . . . .
C.1.	Strength of vehicle structure . . . . .
C.2.	Lifting and jacking . . . . .
C.3.	Running dynamic behaviour . . . . .
ANNEX D:	ENERGY METER . . . . .
ANNEX E:	ANTHROPOMETRIC MEASUREMENTS OF THE DRIVER . . . . .
ANNEX F:	FRONT VISIBILITY . . . . .
F.1.	General . . . . .
F.2.	Reference position of vehicle in relation to track . . . . .
F.3.	Reference position for the eyes of crew members . . . . .



**▼ B**

F.4.	Conditions of visibility .....
ANNEX G:	.....
ANNEX H:	ASSESSMENT OF THE ROLLING STOCK SUBSYSTEM .....
H.1.	Scope .....
H.2.	Characteristics and modules .....
ANNEX I:	ASPECTS FOR WHICH THE TECHNICAL SPECIFICATION IS NOT AVAILABLE (OPEN POINTS) .....
ANNEX J:	STANDARDS OR NORMATIVE DOCUMENTS REFERRED TO IN THIS TSI .....

## 1. INTRODUCTION

1.1. **Technical scope**

This technical specification for interoperability (TSI) is a specification by which a particular subsystem is addressed in order to meet the essential requirements and ensure the interoperability of the trans-European conventional rail system as described in Directive 2008/57/EC.

The particular subsystem is the rolling stock of the trans-European conventional rail system referred to in Annex I Section 1 of Directive 2008/57/EC.

This TSI also includes the rolling stock subsystem as defined in Annex II Section 2.6 of Directive 2008/57/EC and the related parts of the energy subsystem ('onboard part of the electric consumptions measuring equipment' as defined in Annex II Section 2.2 of Directive 2008/57/EC) which corresponds to the onboard part of the energy structural subsystem.

This TSI is applicable to rolling stock:

- which is (or is intended to be) operated on the rail network defined in the Section 1.2 'Geographical scope' of this TSI,
- and
- which is of one of the following types (as defined in Annex I Section 1.2 of Directive 2008/57/EC):
  - self-propelling thermal or electric trains,
  - thermal or electric traction units,
  - passenger carriages,
  - mobile railway infrastructure construction and maintenance equipment.

More information about the rolling stock in the scope of this TSI is given in Section 2 of this Annex.

1.2. **Geographical scope**

- The geographical scope of this TSI is the trans-European conventional rail system network (TEN) as described in Annex I Section 1.1 'Network' of Directive 2008/57/EC.
- The requirements for high speed rolling stock designed to operate on the Trans European High-Speed Rail system as provided for in Annex I (2.2) of Directive 2008/57/EC, at maximum speed intended for this high-speed network, are not covered in this TSI.

**▼B**

- The additional requirements to this TSI that may be necessary for safe operation on high-speed networks of conventional rolling stock of maximum speed lower than 190 km/h which are in the scope of this TSI (as defined in clause 2.3 below) are identified as an open point in the current version of this TSI.

1.3. **Content of this TSI**

In accordance with Article 5(3) of Directive 2008/57/EC this TSI:

- (a) indicates its intended scope (Section 2);
- (b) lays down essential requirements for the concerned rolling stock domain and for its interfaces vis-à-vis other subsystems (Section 3);
- (c) establishes the functional and technical specifications to be met by the subsystem and its interfaces vis-à-vis other subsystems (Section 4);
- (d) determines the interoperability constituents and interfaces which must be covered by European specifications, including European standards, which are necessary to achieve interoperability within the trans-European conventional rail system (Section 5);
- (e) states, in each case under consideration, which procedures are to be used in order to assess the conformity or the suitability for use of the interoperability constituents, on the one hand, or the 'EC' verification of the subsystems, on the other hand (Section 6);
- (f) indicates the strategy for implementing this TSI (Section 7);
- (g) indicates for the staff concerned, the professional qualifications and health and safety conditions at work required for the operation and maintenance of the subsystem, as well as for the implementation of this TSI (Section 4).

In accordance with Article 5(5) of Directive 2008/57/EC, provision may be made for specific cases for each TSI; such provisions are indicated in Section 7.

1.4. **Referenced documents**

- Conventional rail 'Locomotives and passenger rolling stock' TSI (CR LOC & PAS TSI): present document.

Legislative measures in force:

- Directive 2008/57/EC.

**▼M1**

- Control-Command and Signalling TSI.

**▼B**

- High-speed RST TSI: Commission Decision 2008/232/EC <sup>(1)</sup>
- Accessibility for people with reduced mobility (PRM) TSI: Commission Decision 2008/164/EC <sup>(2)</sup>.
- Safety in railway tunnels (SRT) TSI: Commission Decision 2008/163/EC <sup>(3)</sup>.

<sup>(1)</sup> OJ L 84, 26.3.2008, p. 132.

<sup>(2)</sup> OJ L 64, 7.3.2008, p. 72.

<sup>(3)</sup> OJ L 64, 7.3.2008, p. 1.

**▼B**

- Conventional rail noise TSI: Commission Decision 2006/66/EC <sup>(1)</sup>.
- Conventional rail freight wagons TSI (CR WAG TSI): Commission Decision 2006/861/EC <sup>(2)</sup>, amended by Commission Decision 2009/107/EC <sup>(3)</sup>.
- Conventional rail traffic operation and management (OPE) TSI: Commission Decision 2006/920/EC <sup>(4)</sup>, amended by Decision 2009/107/EC.
- Common safety methods (CSM): Commission Regulation (EC) No 352/2009 <sup>(5)</sup>.

Legislative measures under adoption process:

- Conventional rail infrastructure TSI (CR INF TSI).
- Conventional rail energy TSI (CR ENE TSI).
- Description of modules for conformity assessment.
- Revision of the operation TSI (Annexes P and T).

Legislative measures under development:

- Telematic application for passengers TSI (TAP-TSI).

## 2. ROLLING STOCK SUBSYSTEM AND FUNCTIONS

### 2.1. **The rolling stock subsystem as part of the conventional rail system**

The trans-European rail system comprises a high speed rail system and a conventional rail system.

According to Directive 2008/57/EC, the rolling stock subsystem of the trans-European high-speed rail system includes trains designed to operate on the trans-European high speed rail network (HS TEN), composed of lines either dedicated high-speed lines or lines upgraded for high speed (i.e. speed of the order of 200 km/h or more) indicated as such in Annex 1 of Decision No 1692/96/EC of the *European Parliament and of the Council* <sup>(6)</sup>.

*Note:* The HS RST TSI Section 1.1 sets a speed threshold of 190 km/h for the rolling stock in its technical scope.

According to Directive 2008/57/EC, the rolling stock subsystem of the trans European conventional rail system includes all trains likely to travel on all or part of the conventional lines of the TEN; the maximum operational speed of these trains is not specified.

The conventional rail system has been broken down into subsystems as defined in Annex II (section 1) to of Directive 2008/57/EC and listed as follows.

Structural areas:

- infrastructure,

<sup>(1)</sup> OJ L 37, 8.2.2006, p. 1.

<sup>(2)</sup> OJ L 344, 8.12.2006, p. 1.

<sup>(3)</sup> OJ L 45, 14.2.2009, p. 1.

<sup>(4)</sup> OJ L 359, 18.12.2006, p. 1.

<sup>(5)</sup> OJ L 108, 29.4.2009, p. 4.

<sup>(6)</sup> OJ L 228, 9.9.1996, p. 1.

**▼B**

- energy,
- control-command and signalling,
- rolling stock.

Functional areas:

- traffic operation and management,
- maintenance,
- telematics applications for passenger and freight services.

With the exception of maintenance, each subsystem is dealt with in specific TSI(s).

The rolling stock subsystem dealt with in this TSI (as defined in Section 1.1) has interfaces with all other subsystems of the conventional rail system mentioned above; these interfaces are considered within the frame of an integrated system, compliant with all relevant TSIs.

Further to the development of the second TSI group there are:

- two TSIs describing specific aspects of the railway system and concerning several subsystems, the conventional rail rolling stock being one of them:
  - (a) safety in railway tunnels;
  - (b) accessibility for people with reduced mobility;
 and
- two TSIs concerning the conventional rail rolling stock subsystem:
  - (c) noise;
  - (d) freight wagons.

The requirements concerning the rolling stock subsystem expressed in these four TSIs are not repeated in this TSI.

## 2.2. **Definitions related to rolling stock**

For the purpose of this TSI, the following definitions apply:

### **Train formation:**

- A 'unit' is the generic term used to name the rolling stock which is subject to the application of this TSI, and therefore subject to a certificate of 'EC' verification.

A unit may be composed of several 'vehicles', as defined in Directive 2008/57/EC, Article 2(c); considering the scope of this TSI, the use of the term 'vehicle' in this TSI is limited to the rolling stock subsystem.

- A 'train' is an operational formation consisting of one or more units.
- A 'passenger train' is an operational formation accessible to passengers (a train composed of passenger vehicles but not accessible to passengers is not considered as a passenger train).
- A 'fixed formation' is a train formation that can only be reconfigured within a workshop environment.

**▼B**

- A ‘predefined formation(s)’ is a train formation(s) of several units coupled together, which is defined at design stage and can be reconfigured during operation.
- ‘Multiple operation’: where ‘multiple operation’ is required:
  - trainsets are designed so that several of them (of the type under assessment) are capable of being coupled together to operate as a single train controlled from 1 driver’s cab,
  - locomotives are designed so that several of them (of the type under assessment) are capable of being included in a single train controlled from 1 driver’s cab.
- ‘General operation’: a unit is designed for general operation when the unit is intended to be coupled with other unit(s) in a train formation which **is not defined** at design stage.

**Rolling stock:**

A — Self-propelling thermal and/or electric trains:

A ‘trainset’ is a fixed formation that can operate as a train; it is by definition not intended to be reconfigured, except within a workshop environment. It is composed of only motored or of motored and non-motored vehicles.

‘An electric and/or diesel multiple unit’ is a trainset in which all vehicles are capable of carrying passengers or luggage/mail.

A ‘railcar’ is a vehicle that can operate autonomously and is capable of carrying passengers or luggage/mail.

B — Thermal or electric traction units:

A ‘locomotive’ is a traction vehicle (or combination of several vehicles) that is not intended to carry a payload and has the ability to uncouple in normal operation from a train and to operate independently.

A ‘shunter’ is a traction unit designed for use only on shunting yards, stations and depots.

Traction in a train can also be provided by a powered vehicle with or without driving cab, which is not intended to be uncoupled during normal operation. Such a vehicle is called a ‘power car’ in general or a ‘power head’ when located at one end of the trainset and fitted with a driving cab.

C — Passenger carriages and other related cars:

A ‘coach’ is a non-traction vehicle in a fixed or variable formation capable of carrying passengers (by extension, requirements specified to apply to coaches in this TSI are deemed to apply also to restaurant cars, sleeping cars, couchettes cars, etc.). A coach may be equipped with a driver’s cab; such a coach is then named a ‘driving coach’.

**▼B**

A ‘van’ is a non-traction vehicle capable of carrying payload other than passengers, e.g. luggage or mail, intended to be integrated into a fixed or variable formation which is intended to transport passengers. A van may be fitted with a driver’s cab and as such is known as a ‘driving van’.

A ‘driving trailer’ is a non-traction vehicle equipped with a driving cab.

A ‘car carrier’ is a non-traction vehicle capable of carrying passenger motor cars without their passengers and which is intended to be integrated in a passenger train.

A ‘fixed rake of coaches’ is a non-traction formation of several coaches ‘semi-permanently’ coupled together, or which can be reconfigured only when it is out of service.

D — Mobile railway infrastructure construction and maintenance equipment (or on-track machines)

‘On track machines (OTMs)’ are vehicles specially designed for construction and maintenance of the track and infrastructure. OTMs are used in different modes: working mode, transport mode as self-propelling vehicle, transport mode as a hauled vehicle.

‘Infrastructure inspection vehicles’ utilised to monitor the condition of the infrastructure are considered as OTMs as defined above.

### 2.3. **Rolling stock in the scope of this TSI**

The scope of this TSI concerning rolling stock, classified according to the types of rolling stock defined in Section 1.1, is detailed as follows:

A — Self-propelling thermal or/and electric trains:

This type includes any passenger train in fixed or pre-defined formation.

Thermal or electric traction equipment is installed in some vehicles of the train, and the train is fitted with a driver’s cab.

Exclusion from the scope:

Rolling stock designed to operate primarily on urban tramway or light rail networks and intended to carry passengers in urban and suburban areas is not in the scope of this TSI in its version.

Railcars or electric and/or diesel multiple units intended to operate on explicitly identified local (suburban or regional) networks which are not parts of TEN lines are not in the scope of this TSI in its current version.

When these types of rolling stock are intended to operate over very short distances on the TEN lines, due to the local configuration of the railway network, Articles 24 and 25 of Directive 2008/57/EC (referring to national rules) are applicable.

B — Thermal or electric traction units:

This type includes traction vehicles that are not capable of carrying a payload, such as thermal or electric locomotives or power heads.

**▼ B**

The concerned traction vehicles are intended for freight or/and passenger transport.

Exclusion from the scope:

Shunters, which are as defined not intended to operate on the main lines of the TEN, are not in the scope of this TSI in its current version.

When they intended to operate shunting movements (short distances) on the main lines of the TEN, Articles 24 and 25 of Directive 2008/57/EC (referring to national rules) are applicable.

C — Passenger carriages and other related cars:

— Passenger carriages:

This type includes non-traction vehicles carrying passengers, and operated in a variable formation with vehicles from the category ‘thermal or electric traction units’ defined above to provide the traction function.

— Non-passenger carrying vehicles included in a passenger train:

— Non-traction vehicles included in passenger trains (e.g. luggage or postal vans, car carriers, vehicles for service...) are in the scope of this TSI, by extension of the concept of passenger carriages.

Exclusion from the scope:

— Freight wagons are not in the scope of this TSI; they are covered by the ‘freight wagons’ TSI even when they are included in a passenger train (the train composition is in this case an operational issue).

— Vehicles intended to carry road motor vehicles, with persons onboard these road motor vehicles, are not in the scope of this TSI.

D — Mobile railway infrastructure construction and maintenance equipment:

This type of rolling stock is in the scope of the TSI only when:

- it is running on its own rail wheels,
- it is designed to be detected by a track based train detection system for traffic management, and
- it is in transport (running) configuration on its own rail wheels, self-propelled or hauled.

Working configuration is outside the scope of this TSI.

### 3. ESSENTIAL REQUIREMENTS

#### 3.1. General

According to Article 4(1) of Directive 2008/57/EC, the trans-European conventional rail system, its subsystems and its interoperability constituents shall fulfil the essential requirements set out in general terms in Annex III of Directive 2008/57/EC.

**▼B**

In the scope of this TSI, compliance with the specifications described in Section 4 for the subsystems, or Section 5 for the interoperability constituents and demonstrated by a positive result of the assessment described in Section 6.1 for the conformity and/or suitability for use of the interoperability constituents or Section 6.2 for the verification of the subsystems, ensures fulfilment of the relevant essential requirements quoted in Section 3.2.

Nevertheless, if part of the essential requirements are covered by national rules because of open points declared in the TSI or specific cases described in Section 7.3, the corresponding national rules shall include the conformity assessment, which shall be carried out under the responsibility of the relevant Member State.

### 3.2. **Elements of the rolling stock subsystem corresponding to the essential requirements**

Regarding the rolling stock subsystem, the following table indicates the essential requirements, as defined and numbered in Annex III of Directive 2008/57/EC, that are met by the specifications set out in Section 4 of this TSI.

**Rolling stock elements corresponding to essential requirements**

Element of the rolling stock subsystem	Ref. clause	Safety	Reliability-availability	Health	Environmental protection	Technical compatibility
Inner coupling	4.2.2.2.2	1.1.3 2.4.1				
End coupling	4.2.2.2.3	1.1.3 2.4.1				
Rescue coupling	4.2.2.2.4		2.4.2			2.5.3
Staff access for coupling and uncoupling	4.2.2.2.5	1.1.5		2.5.1		2.5.3
Gangways	4.2.2.3	1.1.5				
Strength of vehicle structure	4.2.2.4	1.1.3 2.4.1				
Passive safety	4.2.2.5	2.4.1				
Lifting and jacking	4.2.2.6					2.5.3
Fixing of devices to car body structure	4.2.2.7	1.1.3				
Staff and freight access doors	4.2.2.8	1.1.5 2.4.1				
Mechanical characteristics of glass	4.2.2.9	2.4.1				
Load conditions and weighted mass	4.2.2.10	1.1.3				
Gauge — Kinematic gauge	4.2.3.1					2.4.3
Axle load	4.2.3.2.1					2.4.3
Wheel load	4.2.3.2.2	1.1.3				
Rolling stock parameters which influence CCS subsystem	4.2.3.3.1	1.1.1				2.4.3 2.3.2
Axle bearing condition monitoring	4.2.3.3.2	1.1.1	1.2			
Safety against derailment running on twisted track	4.2.3.4.1	1.1.1 1.1.2				2.4.3
Running dynamic behaviour	4.2.3.4.2	1.1.1 1.1.2				2.4.3
Limit values for running safety	4.2.3.4.2.1	1.1.1 1.1.2				2.4.3
Track loading limit values	4.2.3.4.2.2					2.4.3



## ▼B

Element of the rolling stock subsystem	Ref. clause	Safety	Reliability-availability	Health	Environmental protection	Technical compatibility
Equivalent conicity	4.2.3.4.3	1.1.1 1.1.2				2.4.3
Design values for new wheel profiles	4.2.3.4.3.1	1.1.1 1.1.2				2.4.3
In-service values of wheelset equivalent conicity	4.2.3.4.3.2	1.1.2	1.2			2.4.3
Structural design of bogie frame	4.2.3.5.1	1.1.1 1.1.2				
Mechanical and geometrical characteristics of wheelsets	4.2.3.5.2.1	1.1.1 1.1.2				2.4.3
Mechanical and geometrical characteristics of wheels	4.2.3.5.2.2	1.1.1 1.1.2				
Variable gauge wheelsets	4.2.3.5.2.3	1.1.1 1.1.2				
Minimum curve radius	4.2.3.6	1.1.1 1.1.2				2.4.3
Life guards	4.2.3.7	1.1.1				
Braking — Functional requirements	4.2.4.2.1	1.1.1 2.4.1	2.4.2			1.5
Braking — Safety requirements	4.2.4.2.2	1.1.1	1.2 2.4.2			
Type of brake system	4.2.4.3					2.4.3
Emergency braking command	4.2.4.4.1	2.4.1				2.4.3
Service braking command	4.2.4.4.2					2.4.3
Direct braking command	4.2.4.4.3					2.4.3
Dynamic braking command	4.2.4.4.4	1.1.3				
Parking braking command	4.2.4.4.5					2.4.3
Braking performance -General requirements	4.2.4.5.1	1.1.1 2.4.1	2.4.2			1.5
Emergency braking	4.2.4.5.2	2.4.1				2.4.3
Service braking	4.2.4.5.3					2.4.3
Calculations related to thermal capacity	4.2.4.5.4	2.4.1				2.4.3
Parking brake	4.2.4.5.5	2.4.1				2.4.3
Limit of wheel rail adhesion profile	4.2.4.6.1	2.4.1	1.2 2.4.2			
Wheel slide protection system	4.2.4.6.2	2.4.1	1.2 2.4.2			
Dynamic brake — Braking systems linked to traction system	4.2.4.7		1.2 2.4.2			
Braking system independent of adhesion conditions — General	4.2.4.8.1.		1.2 2.4.2			
Magnetic track brake	4.2.4.8.2.					2.4.3
Eddy current track brake	4.2.4.8.3					2.4.3
Brake state and fault indication	4.2.4.9	1.1.1	1.2 2.4.2			

## ▼B

Element of the rolling stock subsystem	Ref. clause	Safety	Reliability-availability	Health	Environmental protection	Technical compatibility
Brake requirements for rescue purposes	4.2.4.10		2.4.2			
Sanitary systems	4.2.5.1				1.4.1	
Public address system: audible communication system	4.2.5.2	2.4.1				
Passenger alarm: functional requirements	4.2.5.3	2.4.1				
Safety instructions to passengers — Signs	4.2.5.4	1.1.5				
Communication devices for passengers	4.2.5.5	2.4.1				
Exterior doors: access to and egress from Rolling stock	4.2.5.6	2.4.1				
Exterior doors: system construction	4.2.5.7	1.1.3 2.4.1				
inter-unit doors	4.2.5.8	1.1.5				
Internal air quality	4.2.5.9			1.3.2		
body side windows	4.2.5.10	1.1.5				
Environmental conditions	4.2.6.1		2.4.2			
Slipstream effects on passengers on platform	4.2.6.2.1	1.1.1		1.3.1		
Slipstream effects on workers at the track side	4.2.6.2.2	1.1.1		1.3.1		
Head pressure pulse	4.2.6.2.3					2.4.3
Maximum pressure variations in tunnels	4.2.6.2.4					2.4.3
Cross wind	4.2.6.2.5	1.1.1				
Head lights	4.2.7.1.1					2.4.3
Marker lights	4.2.7.1.2	1.1.1				2.4.3
Tail lights	4.2.7.1.3	1.1.1				2.4.3
Lamp controls	4.2.7.1.4					2.4.3
Horn — General	4.2.7.2.1	1.1.1				2.4.3 2.6.3
Warning horn sound pressure levels	4.2.7.2.2	1.1.1		1.3.1		
Protection	4.2.7.2.3					2.4.3
Horn control	4.2.7.2.4	1.1.1				2.4.3
Traction performance	4.2.8.1					2.4.3 2.6.3
Power supply	4.2.8.2 4.2.8.2.1 to 4.2.8.2.9					1.5 2.4.3 2.2.3
Electrical protection of the train	4.2.8.2.10	2.4.1				
Diesel and other thermal traction system	4.2.8.3	2.4.1				1.4.1
Protection against electrical hazards	4.2.8.4	2.4.1				
Driver's cab — General	4.2.9.1.1	—	—	—	—	—
Access and egress	4.2.9.1.2	1.1.5				2.4.3
External visibility	4.2.9.1.3	1.1.1				2.4.3
Interior layout	4.2.9.1.4	1.1.5				
Driver's seat	4.2.9.1.5			1.3.1		
Driver's desk- Ergonomics	4.2.9.1.6	1.1.5		1.3.1		

**▼B**

Element of the rolling stock subsystem	Ref. clause	Safety	Reliability-availability	Health	Environmental protection	Technical compatibility
Climate control and air quality	4.2.9.1.7			1.3.1		
Internal lighting	4.2.9.1.8					2.6.3
Windscreen — Mechanical characteristics	4.2.9.2.1	2.4.1				
Windscreen — Optical characteristics	4.2.9.2.2					2.4.3
Windscreen — Equipment	4.2.9.2.3					2.4.3
Driver's activity control function	4.2.9.3.1	1.1.1				2.6.3
Speed indication	4.2.9.3.2	1.1.5				
Driver display unit and screens	4.2.9.3.3	1.1.5				
Controls and indicators	4.2.9.3.4	1.1.5				
Labelling	4.2.9.3.5					2.6.3
Remote control function from ground	4.2.9.3.6	1.1.1				
Onboard tools and portable equipment	4.2.9.4	2.4.1				2.4.3 2.6.3
Storage facility for staff personal effects	4.2.9.5	—	—	—	—	—
Recording device	4.2.9.6					2.4.4
Fire safety — Material requirements	4.2.10.2	1.1.4		1.3.2	1.4.2	
Specific measures for flammable liquids	4.2.10.3	1.1.4				
Passenger evacuation	4.2.10.4	2.4.1				
Fire barriers	4.2.10.5	1.1.4				
Train exterior cleaning	4.2.11.2					1.5
Toilet discharge system	4.2.11.3					1.5
Water refilling equipment	4.2.11.4			1.3.1		
Interface for water refilling	4.2.11.5					1.5
Special requirements for stabling of trains	4.2.11.6					1.5
Refuelling equipment	4.2.11.7					1.5
General documentation	4.2.12.2					1.5
Documentation related to maintenance	4.2.12.3	1.1.1				2.5.1 2.5.2 2.6.1 2.6.2
Operating documentation	4.2.12.4	1.1.1				2.4.2 2.6.1 2.6.2
Lifting diagram and instructions	4.2.12.5					2.5.3
Rescue related descriptions	4.2.12.6		2.4.2			2.5.3

Note: Only clauses of the Section 4.2 which contain requirements are listed.

**▼B****3.3. Essential requirements not covered by this TSI**

Essential requirements classified as ‘general requirements’ or ‘specific to other subsystems’ in the Annex III of Directive 2008/57/EC have for some of them an impact on; the rolling stock subsystem; those that are not covered, or are covered with limitations within the scope of this TSI are identified below.

**3.3.1. *General requirements, requirements related to maintenance and operation***

The numbering of the paragraphs and the essential requirements hereunder are those set out in Annex III of Directive 2008/57/EC.

The essential requirements that are not covered within the scope of this TSI are the following:

**1.4. Environmental protection**

- 1.4.1. ‘The environmental impact of establishment and operation of the rail system must be assessed and taken into account at the design stage of the system in accordance with the Community provisions in force.’

This essential requirement is covered by the relevant European provisions in force.

- 1.4.3. ‘The rolling stock and energy-supply systems must be designed and manufactured in such a way as to be electromagnetically compatible with the installations, equipment and public or private networks with which they might interfere.’

This essential requirement is covered by the relevant European provisions in force.

- 1.4.4. ‘Operation of the rail system must respect existing regulations on noise pollution.’

This essential requirement is covered by the noise TSI in force.

- 1.4.5. ‘Operation of the rail system must not give rise to an inadmissible level of ground vibrations for the activities and areas close to the infrastructure and in a normal state of maintenance.’

This essential requirement is covered by the CR Infrastructure TSI (open point in the current version).

**2.5. Maintenance**

These essential requirements are relevant within the scope of this TSI according to Section 3.2 of this TSI only for the technical maintenance documentation related to the rolling stock subsystem; they are not in the scope of this TSI regarding maintenance installations.

**2.6. Operation**

These essential requirements are relevant within the scope of this TSI according to Section 3.2 of this TSI for the operation documentation related to the rolling stock subsystem (essential requirements 2.6.1 and 2.6.2), and for technical compatibility of the rolling stock with operating rules (essential requirements 2.6.3).

**▼ B**3.3.2. *Requirements specific to other subsystems*

Requirements on the relevant other subsystems are necessary to fulfil these essential requirements for the whole railway system.

The requirements on the rolling stock subsystem which contribute to the fulfilment of these essential requirements are mentioned in the Section 3.2 of this TSI, and are those set out in Sections 2.2.3 and 2.3.2 of Annex III to Directive 2008/57/EC.

Other essential requirements are not covered within the scope of this TSI.

## 4. CHARACTERISATION OF THE ROLLING STOCK SUBSYSTEM

4.1. **Introduction**4.1.1. *General*

The trans-European conventional rail system, to which Directive 2008/57/EC applies and of which the rolling stock subsystem is a part, is an integrated system whose consistency shall be verified. This consistency shall be checked in particular with regard to the specifications of the rolling stock subsystem, its interfaces in relation to the other subsystems of the Conventional Rail system in which it is integrated, as well as the operating and maintenance rules.

The basic parameters of the rolling stock subsystem are defined in the present Section 4 of this TSI.

Except where this is strictly necessary for the interoperability of the trans-European conventional rail network, the functional and technical specifications of the subsystem and its interfaces described in Sections 4.2 and 4.3, do not impose the use of specific technologies or technical solutions.

Innovative solutions, which do not fulfil the requirements specified in this TSI and/or which are not assessable as stated in this TSI, require new specifications and/or new assessment methods. In order to allow technological innovation, these specifications and assessment methods shall be developed by the process 'innovative solution' described in Section 6.

Characteristics that need to be listed in the 'European register of authorised types of vehicles' are identified in Section 4.8 of this TSI.

4.1.2. *Description of the rolling stock subject to the application of this TSI*

Rolling stock subject to the application of this TSI (designated as a unit in the context of this TSI) shall be described in the certificate of 'EC' verification, using one of the following characteristics:

- Trainset in fixed formation and, when required, predefined formation(s) of several trainsets of the type under assessment for multiple operation.
- Single vehicle or fixed rakes of vehicles intended for predefined formation(s)
- Single vehicle or fixed rakes of vehicles intended for general operation and when required, predefined formation(s) of several vehicles (locomotives) of the type under assessment for multiple operation.

**▼ B**

*Note:* Multiple operation of the unit under assessment with other types of rolling stock is not in the scope of this TSI.

Definitions related to train formation and units are given in Section 2.2 of this TSI.

When a unit intended for use in fixed or predefined formation(s) is assessed, the formations for which such assessment is valid shall be defined by the party asking for assessment, and stated in the certificate of 'EC' verification. The definition of each formation shall include the type designation of each vehicle, the number of vehicles and their arrangement in the formation. Details are given in Section 6.2.

Some characteristics or some assessments of a unit intended to be used in general operation, will require defined limits regarding the train formations. These limits are laid down in Section 4.2 and in clause 6.2.6.

#### 4.1.3. *Main categorisation of the rolling stock for application of TSI requirements*

A rolling stock technical categorisation system is used in the following clauses of this TSI to define relevant requirements applicable to a unit.

The technical category(ies) relevant for the unit subject to the application of this TSI shall be identified by the party asking for assessment. This categorisation shall be used by the notified body in charge of the assessment, in order to assess the applicable requirements from this TSI, and shall be stated in the certificate of 'EC' verification.

The technical categories of rolling stock are the following:

- Unit designed to carry passengers.
- Unit designed to carry passenger-related load (luggage, cars, etc.).
- Unit fitted with a driver's cab.
- Unit fitted with traction equipment.
- Electric unit, defined as a unit supplied with electric energy by an electrification system specified in the CR energy TSI.
- Freight locomotive: Unit designed to haul freight wagons.
- Passenger locomotive: Unit designed to haul passenger carriages.
- Track construction and maintenance equipment (OTMs).

A unit can fall into one or several of the categories above.

Unless stated otherwise in the clauses of the Section 4.2, requirements specified in this TSI apply to all technical categories of rolling stock defined above.

The unit operational configuration shall also be considered when it is assessed; a distinction shall be made between:

- a unit that can be operated as a train,
- a unit that cannot be operated alone, and that has to be coupled with other unit(s) to be operated as a train (see also clauses 4.1.2, 6.2.6 and 6.2.7).

**▼B**4.1.4. *Categorisation of the rolling stock for fire safety*

In respect of fire safety requirements, three categories of rolling stock are defined and specified in the clause 4.2.10 of this TSI.

In line with the HS RST TSI and SRT TSI, all rolling stock in the scope of this TSI shall be classified into (at least) one of the categories:

- Category A fire safety,
- Category B fire safety,
- Freight locomotive and OTM.

4.2. **Functional and technical specification of the subsystem**4.2.1. *General*4.2.1.1. *Breakdown*

In light of the essential requirements in Section 3, the functional and technical specifications of the rolling stock subsystem are grouped and sorted out in the following clauses of this section:

- Structures and mechanical parts
- Track interaction and gauging
- Braking
- Passenger related items
- Environmental conditions
- External lights and audible and visible warning devices
- Traction and electrical equipment
- Driver's cab and driver-machine interface
- Fire safety and evacuation
- Servicing
- Documentation for operation and maintenance

For particular technical aspects, the functional and technical specification makes an explicit reference to a clause of an EN standard or other technical document, as allowed by Article 5(8) of Directive 2008/57/EC; these references are listed in the Annex J of this TSI.

Information needed on board for the train staff to be aware of the operational state of the train (normal state, equipment out of order, degraded situation ...) are described in the clause dealing with the relevant function, and in clause 4.2.12 'documentation requested for the operation and maintenance'.

4.2.1.2. *Open points*

When, for a particular technical aspect, the functional and technical specification necessary to meet the essential requirements has not been developed, and therefore is not included in this TSI, this aspect is identified as an open point in the relevant clause; Annex I of this TSI lists all open points, as required in Article 5(6) of Directive 2008/57/EC.

**▼B**

The Annex I mentions also if the open points relate to technical compatibility with the network; for this purpose, the Annex I is split in 3 parts:

- General open points that apply to a whole network.
- Open points that relate to technical compatibility between the vehicle and the network.
- Open points that do not relate to technical compatibility between the vehicle and the network.

As required in Article 17(3) of Directive 2008/57/EC, open points shall be addressed by the application of national technical rules.

#### 4.2.1.3. Safety aspects

The functions that contribute to meet the essential requirements 'safety' are identified in Section 3.2 of this TSI.

Most of the safety requirements related to these functions are covered by the technical specifications expressed in Section 4.2 (e.g. 'passive safety', 'wheels' ...).

For the following safety related functions, the technical specifications need to be completed by requirements expressed in terms of safety requirement, for which the demonstration of compliance may use the principles described in the CSM on RA (similarity with reference system(s), application of codes of practice, probabilistic approach):

- Dynamic behaviour (when active control is utilised), as specified in clause 4.2.3.4.2.
- Emergency braking performance (including traction cut off), as specified in clause 4.2.4.2, clause 4.2.4.7 and clause 4.2.4.8.1; the safety requirements are specified in clause 4.2.4.2.2.
- Parking braking, as specified in clause 4.2.4.2, clause 4.2.4.4.5 and clause 4.2.4.5.5; the safety requirements are specified in clause 4.2.4.2.2.
- Brake state and fault indication, as specified in clause 4.2.4.9.
- Passenger alarm, as specified in clause 4.2.5.3.
- Control of passenger exterior doors, as specified in clause 4.2.5.6.
- Electric power supply cut off, as specified in clause 4.2.8.2.10.
- Driver's activity control, as specified in clause 4.2.9.3.1.
- Fire barriers (other than full cross section partitions), as specified in clause 4.2.10.5.

Where these functions, identified as safety related, have their safety aspects not sufficiently covered, or no safety specified, this is identified as an open point in the corresponding clause specifying the function.

Software which is used to fulfil safety related functions shall be developed and assessed according to a methodology adequate for safety related software.



**▼B**

This applies to software which has an impact on functions identified as safety related in the Section 4.2 of this TSI.

4.2.2. *Structure and mechanical parts*4.2.2.1. *General*

This part addresses requirements relating to the design of vehicle structural body (strength of vehicle structure) and of the mechanical links (mechanical interfaces) between vehicles or between units.

Most of these requirements aim at ensuring the train's mechanical integrity in operation and rescue operation as well as protecting passenger and staff compartments in the event of collision or derailment.

4.2.2.2. *Mechanical interfaces*4.2.2.2.1. *General and definitions*

In order to form a train (as defined in Section 2.2) vehicles are coupled together in a way that enables them to be operated together. The coupling is the mechanical interface that enables this. There are several types of couplings:

- 'Inner' coupling (also called 'intermediate' coupling) is the coupling device between vehicles in order to form a unit composed of several vehicles (e.g. a fixed rake of coaches or a trainset).
- End coupling ('external' coupling) of units is the coupling device used to couple together two (or several) units to form a train. The fitting of end coupling at the end of units is not mandatory. Where there is no coupling at any end of a unit, a device to allow a rescue coupling shall be provided at such end of the unit.

An end coupling can be 'automatic', 'semi-automatic' or 'manual'.

In the context of this TSI, a 'Manual' coupling is an end coupling system which requires (one or several) person(s) to stand between the units to be coupled or uncoupled for the mechanical coupling of these units.

- Rescue coupling is the coupling device that enables a unit to be rescued by a recovery power unit equipped with a 'standard' manual coupling as per clause 4.2.2.2.3 where the unit to be rescued is equipped with a different coupling system or is not equipped with any coupling system.

4.2.2.2.2. *Inner coupling*

Inner couplings between the different vehicles of a unit shall incorporate a resilient system capable of withstanding the forces due to the intended operating conditions.

Where the inner coupling system between vehicles has a lower longitudinal strength than the end coupling(s) of the unit, provisions shall be made to rescue the unit in case of breakage of any such inner coupling; these provisions shall be described in the documentation required in clause 4.2.12.6.

Articulated units: The joint between two vehicles sharing the same running gear, shall comply with the requirements of Sections 6.5.3 and 6.7.5 of the EN12663-1:2010.

**▼B**

## 4.2.2.2.3. End coupling

## (a) End coupling — General

Where an end coupling is provided at any end of a unit, the following requirements apply to all types of end coupling (automatic, semi-automatic or manual):

- End couplings shall incorporate a resilient coupling system, capable of withstanding the forces due to the intended operational and rescue conditions.
- The type of mechanical coupling together with its nominal maximum design values of tensile and compressive forces shall be recorded in the rolling stock register defined in clause 4.8 of this TSI.

There is no further requirement for automatic and semi-automatic coupling systems in this TSI.

## (b) ‘Manual’ coupling system

The following provisions apply specifically to units fitted with a ‘manual’ coupling system:

- The coupling system shall be designed so that no human presence between the units to be coupled/uncoupled is required whilst either one is moving.
- Coaches with manual coupling systems shall be fitted with a buffer, draw gear and screw coupling system complying with the requirements of the parts of EN15551:2009 and EN15566:2009 related to passenger coaches; Units other than coaches with manual coupling systems shall be fitted with a buffer, draw gear and screw coupling system complying with the relevant parts of EN15551:2009 and EN15566:2009 respectively.

In all cases, the buffers and the screw coupling shall be installed according to clauses A.1 to A.3 of Annex A.

On all units designed to operate solely on the standard 1 435 mm gauge network, and equipped with manual coupling and UIC pneumatic brake, the following requirements apply:

- The dimensions and layout of brake pipes and hoses, couplings and cocks shall meet the requirements stated in the Annex I of the CR WAG TSI. The longitudinal and vertical location of brake pipes and cocks from the buffer plate shall comply with the corresponding requirements set out in UIC leaflet 541-1:Nov 2003 Annex B2 figure 16b or 16c.

*Note:* They will be subject of an EN standard currently under drafting process.

- The lateral location of brake pipes and cocks is permitted to comply with the requirements of UIC 648:Sep 2001.

## (c) Manual coupling system — Compatibility between units designed to be operated on networks with different track gauges

**▼B**

Units designed for operation on networks with several track gauges (e.g. 1 435 mm and 1 520/1 524 mm, or 1 435 mm and 1 668 mm), equipped with 'Manual' coupling and UIC pneumatic brake system, shall be compatible with both:

- The interface requirements in the clause 4.2.2.2.3 'End coupling' for 1 435 mm networks, and
- The associated specific case for the 'other than 1 435 mm' network as depicted in clause 7.3 of this TSI.

4.2.2.2.4. **Rescue coupling**

At the ends of units not equipped with any end coupling feature, or equipped with a coupling system which is not compatible with the manual coupling system as per clause 4.2.2.2.3 of this TSI, provisions shall be made to enable the recovery of the line in case of breakdown by hauling or propelling the unit to be rescued:

- Where the unit to be rescued is fitted with an end coupling: by means of a power unit equipped with the same type of end coupling system, and
- By means of a recovery unit i.e. a power unit featuring at each of its ends intended to be used for rescue purposes:
  - a manual coupling system and pneumatic brake compliant to 4.2.2.2.3 above,
  - lateral location of brake pipes and cocks according to UIC 648:Sep 2001,
  - a free space of 395 mm above the centre line of the hook to allow the fitting of the rescue adaptor as described below.

This is achieved either by means of a permanently installed compatible coupling system or through a rescue coupler (also called rescue adaptor).

In such a case, the unit to be assessed shall be designed so that it is possible to carry the rescue coupler onboard.

The rescue coupler shall:

- be designed to allow the rescue at a speed of at least 30km/h on railway lines which comply with the CR INF TSI,
- be secured after mounting onto the recovery unit in a way that prevents it coming off during the rescue operation,
- withstand the forces due to the intended rescuing conditions,
- be designed such that it does not require any human presence between the recovery unit and the unit to be rescued whilst either one is moving,
- neither the rescue coupler nor any braking hose shall limit the lateral movement of the hook when fitted onto the recovery unit.

The brake interface is covered by the requirements of clause 4.2.4.10 of this TSI.

**▼B****4.2.2.2.5. Staff access for coupling and uncoupling**

Units shall be designed so that staff are not exposed to undue risk during coupling and uncoupling, or rescue operations.

To comply with this requirement, units fitted with manual coupling systems as per clause 4.2.2.2.3 shall comply with the following requirements (the 'Bern rectangle'):

— The required spaces shown in figure A2 of Annex A shall be free of fixed parts. For this requirement the coupling gear components are in the central position laterally.

Connecting cables and flexible hoses as well as elastic deformable parts of gangways may be inside this space. There shall be no devices under the buffers that hinder the access to the space.

— Where a combined automatic and screw coupler is fitted it is permissible for the auto coupler head to infringe the Bern rectangle on the left hand side (as viewed on figure A2) when it is stowed and the screw coupler is in use.

— There shall be a handrail under each buffer. The handrails shall withstand a force of 1,5 kN.

**4.2.2.3. Gangways**

Where a gangway is provided as a means for passengers to circulate from one coach or one trainset to another, it shall not expose passengers to undue risk.

Where operation with the gangway not being connected is foreseen, it shall be possible to prevent access by passengers to the gangway.

Requirements related to the gangway door when the gangway is not in use are specified in clause 4.2.5.8 'Passenger related items — Inter-unit doors'.

Additional requirements are expressed in the PRM TSI (clause 4.2.2.7 of PRM TSI 'Clearways').

These requirements do not apply to the end of vehicles where this area is not intended for regular use by passengers.

**4.2.2.4. Strength of vehicle structure**

This clause applies to all units.

For mobile railway infrastructure construction and maintenance equipment (OTMs), alternative requirements to those expressed in this clause for static load, category and acceleration are set out in Annex C, clause C.1.

The static and dynamic strength (fatigue) of vehicle bodies is relevant to ensure the safety required for the occupants and the structural integrity of the vehicles in train and in shunting operations.

Therefore, the structure of each vehicle shall comply with the requirements of EN 12663-1:2010 Structural requirements of railway vehicle bodies — Part 1, Locomotives and passenger rolling stock (and alternative method for freight wagons). The rolling stock categories to be taken into account shall correspond to category L for locomotives and power units and categories PI or PII for all other types of vehicle within the scope of this TSI, as defined in Section 5.2 of EN 12663-1:2010.

**▼B**

In particular, proof of the capacity of the vehicle body to resist lasting deformations and fractures may be demonstrated by calculations or by testing, according to the conditions set up in the clause 9.2.3.1 of EN 12663-1:2010.

The load conditions to be considered shall be in accordance with clause 4.2.2.10 of this TSI.

The assumptions for aerodynamic loading shall be those described in clause 4.2.6.2.3 of this TSI.

Joining techniques are covered by the above requirements. A verification procedure shall exist to ensure at the production phase that no defect may decrease the mechanical characteristics of the structure.

#### 4.2.2.5. *Passive safety*

Except for units not intended to carry passengers or staff during operation and except for OTMs, this requirement is applicable to all units.

In addition, units which cannot operate up to the collision speeds specified under any of the collision scenarios below are exempted from the provisions related to that collision scenario.

Passive safety is aimed at complementing active safety when all other measures have failed.

For this purpose, the mechanical structure of vehicles shall provide protection of the occupants in the event of a collision by providing means of:

- limiting deceleration,
- maintaining survival space and structural integrity of the occupied areas,
- reducing the risk of overriding,
- reducing the risk of derailment,
- limiting the consequences of hitting a track obstruction.

To meet these functional requirements, units shall comply with the detailed requirements specified in the standard EN15227:2008 related to crashworthiness design category C-I (as per table 1 of EN15227:2008 Section 4), unless specified otherwise below.

The following four reference collision scenarios shall be considered:

- Scenario 1: A front end impact between two identical units,
- Scenario 2: A front end impact with a freight wagon,
- Scenario 3: An impact of the unit with a large road vehicle on a level crossing,
- Scenario 4: An impact of the unit into a low obstacle (e.g. car on a level crossing, animal, rock etc.).

These scenarios are described in table 2 of Section 5 of EN15227:2008.

**▼B**

Within the scope of the present TSI, table 2 application rules are completed by the following:

- The application of requirements related to scenarios 1 and 2 to heavy haul locomotives used only for freight operations and fitted with centre couplers conforming to the Willison (e.g. SA3) or Janney (AAR standard) principle which are intended to operate on the CR TEN lines is an open point.
- The assessment of conformity of locomotives with central cabs with the requirements related to scenario 3 is an open point.

The present TSI specifies crashworthiness requirements applicable within its scope; therefore, Annex A of EN 15227:2008 shall not apply. The requirements of Section 6 of EN15227:2008 shall be applied in relation to the above given reference collision scenarios.

To limit the consequences of hitting a track obstruction, the leading ends of locomotives, power heads, driving coaches and trainsets shall be equipped with an obstacle deflector. The requirements with which obstacle deflectors shall comply are defined in EN15227:2008 §5 table 3 and Section 6.5.

#### 4.2.2.6. Lifting and jacking

Except for OTMs (mobile railway infrastructure construction and maintenance equipment), this clause applies to all units.

Provisions concerning the lifting and jacking of OTMs are specified in Annex C, clause C.2.

It shall be possible to safely lift or jack each vehicle composing the unit, for recovery purposes (following derailment or other accident or incident), and for maintenance purposes.

It shall also be possible to lift or jack any end of the vehicle (including its running gear) with the other end resting on the remaining running gear(s).

To this purpose, designated and marked lifting/jacking points shall be provided.

The geometry and location of the lifting points shall be compliant with Annex B.

Marking of lifting points shall be made by signs compliant with Annex B.

The structure shall resist to the loads specified in EN 12663-1:2010 (section 6.3.2 and 6.3.3).

In particular, proof of the capacity of the vehicle body to resist lasting deformations and fractures may be demonstrated by calculations or by testing, according to the conditions set up in clause 9.2.3.1 of EN 12663-1:2010.

#### 4.2.2.7. Fixing of devices to car body structure

Except for OTMs (mobile railway infrastructure construction and maintenance equipment), this clause applies to all units.

Provisions concerning the structural strength of OTMs are specified in Annex C, clause C.1.

**▼B**

To reduce the consequences of an accident, fixed devices including those inside the passenger areas, shall be attached to the car body structure in a way that prevents these fixed devices becoming loose and presenting a risk of passenger injuries or lead to a derailment. To this aim, attachments of these devices shall be designed according to Section 6.5.2 of the EN 12663-1:2010 for categories defined in clause 4.2.2.4 above.

## 4.2.2.8. Staff and freight access doors

The doors for use of passengers are covered by the clause 4.2.5 of this TSI: 'Passenger related items'. Cab doors are addressed in clause 4.2.9 of this TSI.

This clause addresses doors for freight use and for use of train crew other than cab doors.

Vehicles fitted with a compartment dedicated to train crew or freight shall be equipped with a device to close and lock the doors. The doors shall remain closed and locked until they are intentionally released.

## 4.2.2.9. Mechanical characteristics of glass (other than windscreens)

Where glass is used in glazing (including mirrors), it shall be either laminated or toughened glass which is in accordance with a relevant national or international standard with regard to the quality and area of use, thereby minimising the risk to passenger and staff being injured by breaking glass.

## 4.2.2.10. Load conditions and weighted mass

The following load conditions defined in clause 3.1 of the standard EN 15663:2009 shall be determined:

- Design mass under exceptional payload.
- Design mass under normal payload.
- Design mass in working order.

The hypothesis taken for arriving at the load conditions above shall be in line with the standard EN 15663:2009 (long distance train, other train, payload per m<sup>2</sup> in standing and service areas); they shall be justified and documented in the general documentation described in clause 4.2.12.2.

For OTMs, different load conditions (minimum mass, maximum mass) may be used, in order to take into account optional onboard equipment.

For each load condition defined above, the following information shall be provided in the technical documentation described in clause 4.2.12:

- Total vehicle mass (for each vehicle of the unit).
- Mass per axle (for each axle).
- Mass per wheel (for each wheel).

The load condition 'design mass in working order' shall be measured by vehicle weighing. It is permissible to derive the other load conditions by calculation.

**▼B**

Where a vehicle is declared as conformant to a type (in accordance with clauses 6.2.2.1 and 7.1.3), the weighted total vehicle mass in the load condition 'design mass in working order' shall not exceed by more than 3 % the declared total vehicle mass for that type which is reported in the type or design examination certificate of 'EC' verification.

The design mass of the unit in working order, the design mass of the unit under normal payload and the highest axle load of the individual axles for each one of the 3 load cases shall be recorded in the rolling stock register defined in clause 4.8 of this TSI.

#### 4.2.3. *Track interaction and gauging*

##### 4.2.3.1. Gauging

The gauge is an interface between the unit (vehicle) and the infrastructure described by a common reference contour and associated rules for the calculation. The gauge is a performance parameter specified in clause 4.2.2 of the CR INF TSI and depends on the category of line.

The kinematic reference contour with its associated rules describes the outer dimensions of the unit; it shall be within one of the reference profiles GA, GB or GC (according to clause 4.2.2 of the CR INF TSI). The assumed sway (or flexibility) coefficient for the gauge calculation shall be justified by calculation or measurements as set out in EN 15273-2:2009.

For electric units, the pantograph gauge shall be verified by calculation according to clause A.3.12 of EN 15273-2:2009 to ensure that the pantograph envelope complies with the mechanical kinematic pantograph gauge which in itself is determined according to Annex E of CR ENE TSI, and depends on the choice made for the pantograph head geometry; the two permitted possibilities are defined in clause 4.2.8.2.9.2 of this TSI.

The voltage of the power supply is considered in the infrastructure gauge in order to ensure the proper insulation distances between the pantograph and fixed installations.

The pantograph sway as specified in clause 4.2.14 of CR energy TSI and used for the mechanical kinematic gauge calculation shall be justified by calculations or measurements as set out in EN 15273-2:2009.

The reference contour (i.e. gauge) that the unit complies with (GA, GB or GC) shall be recorded in the rolling stock register defined in clause 4.8 of this TSI.

Any gauge, with a kinematic reference profile smaller than GC, may also be recorded in the register together with the harmonised applicable gauge (GA, GB or GC), provided it is assessed using the kinematic method.



**▼B**

## 4.2.3.2. Axle load and wheel load

## 4.2.3.2.1. Axle load parameter

The axle load is an interface between the unit and the infrastructure. The axle load is a performance parameter of the infrastructure specified in clause 4.2.2 of the CR INF TSI and depends on the Category of Line. It has to be considered in combination with the axle spacing, with the train length and with the maximum allowed speed for the unit on the considered line.

The following characteristics to be used as an interface to the infrastructure shall be part of the general documentation produced when the unit is assessed, and described in clause 4.2.12.2:

- The mass per axle (for each axle) for the 3 load conditions (as defined and required to be part of the documentation in clause 4.2.2.10).
- The position of the axles along the unit (axle spacing).
- The length of the unit.
- The maximum design speed (as required to be part of the documentation in clause 4.2.8.1.2).

Use of this information at operational level for compatibility check between rolling stock and infrastructure (outside the scope of this TSI):

The axle load of each individual axle of the unit to be used as interface parameter to the infrastructure has to be defined by the Railway Undertaking as required in clause 4.2.2.5 of the CR OPE TSI, considering the expected load for the intended service (not defined when the unit is assessed). The axle load in load condition 'design mass under exceptional payload' represents the maximum possible value of the axle load mentioned above.

## 4.2.3.2.2. Wheel load

The ratio of wheel load difference per axle  $q_j$ , shall be evaluated by wheel load measurement, considering the load condition 'design mass in working order'. Wheel load difference higher than 5 % of the axle load are allowed only if demonstrated as acceptable by the test to prove safety against derailment on twisted track specified in the clause 4.2.3.4.1 of this TSI.

## 4.2.3.3. Rolling stock parameters which influence ground based systems

**▼M1**

## 4.2.3.3.1. Rolling Stock characteristics for the compatibility with train detection systems

The set of rolling stock characteristics for compatibility with train detection target systems are given in clauses 4.2.3.3.1.1, 4.2.3.3.1.2 and 4.2.3.3.1.3.

Reference is made to clauses of the specification referenced in Annex A, Index 77 of CCS TSI'

The set of characteristics the rolling stock is compatible with shall be recorded in the rolling stock register as defined in clause 4.8 of this TSI.

**▼ M1**

## 4.2.3.3.1.1. ROLLING STOCK CHARACTERISTICS FOR COMPATIBILITY WITH TRAIN DETECTION SYSTEM BASED ON TRACK CIRCUITS

- Vehicle geometry
  - The maximum distance between two consecutive axles is specified in the specification referenced in clause 3.1.2 of Annex A, Index 77 of CCS TSI (distance  $a_i$  in Figure 1).
  - The maximum distance between buffer end and first axle is specified in the specification referenced in clause 3.1.2 of Annex A, Index 77 of CCS TSI (distance  $b_1$  in Figure 1).
- Vehicle design
  - The minimum axle load in all load conditions is specified in the specification referenced in clause 3.1.7 of Annex A, Index 77 of CCS TSI.
  - The electrical resistance between the running surfaces of the opposite wheels of a wheelset is specified in the specification referenced in clause 3.1.9 of Annex A, Index 77 of CCS TSI and the method to measure is specified in the same clause.
  - For electric units equipped with a pantograph, the minimum impedance between pantograph and each wheel of the train is an open point in the specification referenced in clause 3.2.2 of Annex A, Index 77 of CCS TSI.
- Isolating emissions
  - The limitations of use of sanding equipment are given in the specification referenced in clause 3.1.4 of Annex A, Index 77 of CCS TSI.
  - The limitations of use of composite brake blocks are given in the specification referenced in clause 3.1.6 of Annex A, Index 77 of CCS TSI.
- EMC
  - The requirements related to electromagnetic compatibility are open points in the specification referenced in clauses 3.2.1 and 3.2.2 of Annex A, Index 77 of CCS TSI.
  - The electromagnetic interference limit levels rising from traction currents are an open point in the specification referenced in clause 3.2.2 of Annex A, Index 77 of CCS TSI.

## 4.2.3.3.1.2. ROLLING STOCK CHARACTERISTICS FOR COMPATIBILITY WITH TRAIN DETECTION SYSTEM BASED ON AXLE COUNTERS

- Vehicle geometry
  - The maximum distance between two consecutive axles is specified in the specification referenced in clause 3.1.2, Annex A, Index 77 of CCS TSI.
  - The minimum distance between two consecutive axles of the train is specified in the specification referenced in clause 3.1.2, Annex A, Index 77 of CCS TSI.

**▼ M1**

- At the end of a unit intended to be coupled, the minimum distance between end and first axle of the unit is half of the value specified in the specification referenced in clause 3.1.2, Annex A, Index 77 of CCS TSI.
- The maximum distance between end and first axle is specified in the specification referenced in clause 3.1.2, Annex A, Index 77 of CCS TSI (distance  $b_1$  in Figure 1).
- The minimum distance between end axles of a unit is specified in the specification referenced in clause 3.1.2, Annex A, Index 77 of CCS TSI.
- Wheel geometry
  - Wheel geometry is specified in the clause 4.2.3.5.2.2 of the present TSI.
  - The minimum wheel diameter (speed dependant) is specified in the specification referenced in clause 3.1.3, Annex A, Index 77 of CCS TSI.
- Vehicle design
  - The metal-free space around wheels is an open point in the specification referenced in clause 3.1.3.5, Annex A, Index 77 of CCS TSI.
  - The characteristics of the wheel material regarding magnetic field is specified in the specification referenced in clause 3.1.3.6, Annex A, Index 77 of CCS TSI.
- EMC
  - The requirements related to electromagnetic compatibility are specified in the specification referenced in clauses 3.2.1 and 3.2.2 of Annex A, Index 77 of CCS TSI.
  - The electromagnetic interference limit levels rising from the use of eddy current or magnetic track brakes are an open point in the specification referenced in clause 3.2.3 of Annex A, Index 77 of CCS TSI.

## 4.2.3.3.1.3. ROLLING STOCK CHARACTERISTICS FOR COMPATIBILITY WITH LOOP EQUIPMENT

- Vehicle design
 

The metal-mass of vehicles is an open point in the specification referenced in clause 3.1.7.2 of Annex A, Index 77 of CCS TSI.

**▼ B**

## 4.2.3.3.2. Axle bearing condition monitoring

The axle bearing condition monitoring shall be made possible.

This is permitted to be achieved either by onboard equipment or by using track side equipment.

The requirement for onboard equipment is an open point in this TSI.

In case of monitoring of axle bearing by trackside equipment, the rolling stock shall comply with the following requirements:

- The zone visible to the trackside equipment on rolling stock shall be the area as defined in EN 15437-1:2009 clauses 5.1 and 5.2.

**▼ B**

- The range of working temperature of the axle bearing is an open point.

*Note:* See also clause 4.2.3.5.2.1 regarding axle boxes.

#### 4.2.3.4. Rolling stock dynamic behaviour

##### 4.2.3.4.1. Safety against derailment running on twisted track

The unit (or vehicles composing the unit) shall be designed to ensure safe running on twisted track, taking into account specifically the transition phase between canted and level track and cross level deviations. The compliance with this requirement shall be verified by the procedure defined in clause 4.1 of EN 14363:2005.

For OTMs safety against derailment when running on track twists is permitted to be proved by an approved calculation method. If this is not possible, tests according to the requirements of EN 14363:2005 shall be carried out.

For running on track twists the testing conditions according to EN 14363:2005, clause 4.1 apply for machines with bogies as well as with individual wheel sets.

##### 4.2.3.4.2. Running dynamic behaviour

###### (a) Introduction

This clause 4.2.3.4.2 is applicable to units designed for a speed higher than 60 km/h.

It is not applicable to OTMs (mobile railway infrastructure construction and maintenance equipment); requirements for OTMs are set out in Annex C, clause C.3.

The dynamic behaviour of a vehicle has a strong influence on safety against derailment, running safety and track loading. It is a safety related function, which is covered by the technical requirements of this clause; when software is utilised, the safety level to be considered for developing the software is an open point.

###### (b) Requirements

In order to verify the running dynamic characteristics of a unit (running safety and track loading), the process sets out in EN 14363:2005 clause 5 and in addition for tilting trains in EN 15686:2010 shall be followed, with the amendments expressed below (in this clause and its sub clauses). The parameters described in clauses 4.2.3.4.2.1 and 4.2.3.4.2.2 shall be assessed using criteria defined in EN 14363:2005.

As an alternative to performing on-track tests on two different rail inclinations, as set out in paragraph 5.4.4.4 in EN 14363:2005 it is permitted to perform tests on only one rail inclination if demonstrated that the tests cover the range of contact conditions defined below:

- The parameter equivalent conicity  $\tan \gamma_e$  for tangent track and large radius curves shall be distributed so that  $\tan \gamma_e = 0,2 \pm 0,05$  occurs in a range of the amplitude ( $y$ ) of the wheelset's lateral displacement between +/- 2 and +/- 4 mm for a minimum of 50 % of track sections.

**▼B**

- The instability criterion in EN14363:2005 shall be assessed for low-frequency body motions on at least two track sections with equivalent conicities less than 0,05 (mean value over the track section).
- The instability criterion in EN14363:2005 shall be assessed on at least two track sections with equivalent conicities in accordance with the following table 1:

*Table 1***Conditions for contact conditions in relation to on-track testing**

Maximum vehicle speed	Equivalent conicity
60 km/h < V ≤ 140 km/h	≥ 0,50
140 km/h < V ≤ 200 km/h	≥ 0,40
200 km/h < V ≤ 230 km/h	≥ 0,35
230 km/h < V ≤ 250 km/h	≥ 0,30

In addition to the requirements concerning the test report given in clause 5.6 of EN 14363:2005, the test report shall include information on:

- The track quality on which the unit was tested on, recorded by the monitoring of a consistent set of some of the parameters set out in EN 13848-1:2003/A1:2008, the selected set of parameters depending on available measurement means.
- The equivalent conicity that the unit was tested for.

The test report shall be part of the documentation described in clause 4.2.12.

## (c) Quality of the track for tests and on-track tests:

Tests conditions: EN14363 defines test conditions for on-track tests which have been agreed as a reference. However these test conditions are not always achievable, due to constraints related to the zone where the test is performed, in the following areas:

- Track geometric quality.
- Combinations of speed, curvature, cant deficiency (clause 5.4.2 of EN 14363).

Regarding the track geometric quality, the specification of a reference track for tests, including limits of the track quality parameters which are defined in EN 13848-1, is an open point. Therefore, national rules apply for the definition of these limits, which shall be expressed in consistency with EN 13848-1, in order to be able to evaluate if a test already performed is acceptable.

## 4.2.3.4.2.1. LIMIT VALUES FOR RUNNING SAFETY

The limit values for running safety which the unit shall meet are specified in EN 14363:2005 clause 5.3.2.2, and additionally for tilting trains in EN 15686:2010, with the following modification of the quotient of guiding force and wheel force (Y/Q):

**▼ B**

When the quotient of guiding force and wheel force (Y/Q) limit is exceeded, it is allowed to recalculate the Y/Q estimated maximum value according to the following process:

- create an alternative test zone made up of all track sections with  $300 \text{ m} \leq R \leq 500 \text{ m}$ ,
- for the statistical processing per section, use  $x_i$  (97,5 %) instead of  $x_i$  (99,85 %),
- for statistical processing per zone, replace  $k = 3$  (when using one-dimensional method) or student coefficient  $t$  (N-2; 99 %) (when using two-dimensional method) by student coefficient  $t$  (N-2; 95 %).

Both results (before and after recalculation) shall be recorded in the test report.

## 4.2.3.4.2.2. TRACK LOADING LIMIT VALUES

Except for the quasi static guiding force  $Y_{qst}$ , the limit values for track loading which the unit shall meet when testing with the normal method, are specified in EN 14363:2005 clause 5.3.2.3.

The quasi static guiding force  $Y_{qst}$  limits are specified below.

The quasi-static guiding force  $Y_{qst}$  limit value shall be evaluated for curve radii  $250 \leq R < 400 \text{ m}$ .

The limit value for unrestricted operation of the rolling stock on the TEN network (as defined in TSIs) shall be:  $(Y_{qst})_{lim} = (30 + 10500/R_m) \text{ kN}$ .

Where:  $R_m$  = mean radius of the track sections retained for the evaluation (in metres).

When this limit value is exceeded due to high friction conditions, it is permitted to recalculate the estimated value of  $Y_{qst}$  on the zone after replacing the individual  $(Y_{qst})_i$  values on the track sections 'i' where  $(Y/Q)_{ir}$  (mean value of Y/Q ratio on the inner rail over the section) exceeds 0,40 by:  $(Y_{qst})_i - 50[(Y/Q)_{ir} - 0,4]$ . The values of the  $Y_{qst}$ ,  $Q_{qst}$  and mean curve radius (before and after recalculation) shall be recorded in the test report.

In case the  $Y_{qst}$  value exceeds the limit value expressed above, the operational performance of the rolling stock (e.g. maximum speed) may be limited by the infrastructure, considering track characteristics (e.g. curve radius, cant, rail height).

*Note:* The limit values specified in EN 14363:2005 are applicable for axle loads in the range of those mentioned in the clause 4.2.2 of the CR INF TSI; for track designed for higher axle loads, harmonised track loading limits values are not defined.

## 4.2.3.4.3. Equivalent conicity

The range of values of speed and equivalent conicity for which the unit is designed to be stable shall be specified and recorded in the technical documentation. These values shall be respected for design and in-service conditions.

**▼B**

The equivalent conicity shall be calculated in accordance with EN15302:2008 for the amplitude ( $y$ ) of the wheelset's lateral displacement:

- $y = 3$  mm, if  $(TG - SR) \geq 7$  mm
- $y = \left( \frac{(TG - SR) - 1}{2} \right)$ , if  $5 \text{ mm} \leq (TG - SR) < 7$  mm
- $y = 2$  mm, if  $(TG - SR) < 5$  mm

where TG is the track gauge and SR is the distance between the active faces of the wheelset ( see figure 1).

Units equipped with independently rotating wheels are exempt from the requirements in clause 4.2.3.4.3 of this TSI.

#### 4.2.3.4.3.1. DESIGN VALUES FOR NEW WHEEL PROFILES

This section defines verifications to be performed by calculations in order to ensure that a 'new wheel' profile and the distance between active faces of the wheels is suitable for tracks of the TEN network which comply to the CR Infrastructure TSI.

Wheel profile and the distance between active faces of the wheels (Dimension SR in figure 1, § 4.2.3.5.2.1) shall be selected to ensure that the equivalent conicity limit set out in table 2 is not exceeded when the designed wheelset is modelled passing over the representative sample of track test conditions as specified in table 3.

Table 2

#### Equivalent conicity design limit values

Maximum vehicle operating speed (km/h)	Equivalent conicity limit values	Test conditions (see table 3)
$\leq 60$	N/A	N/A
$> 60$ and $\leq 190$	0,30	All
$> 190$	Values specified in the HS RST TSI apply	Conditions specified in the HS RST TSI apply

Table 3

#### Track test conditions for equivalent conicity representative of the TEN network

Test condition number	Rail head profile	Rail inclination	Track gauge
1	Rail section 60 E 1 defined in EN 13674-1:2003	1 in 20	1 435 mm
2	Rail section 60 E 1 defined in EN 13674-1:2003	1 in 40	1 435 mm
3	Rail section 60 E 1 defined in EN 13674-1:2003	1 in 20	1 437 mm
4	Rail section 60 E 1 defined in EN 13674-1:2003	1 in 40	1 437 mm
5	Rail section 60 E 2 defined in EN 13674-1:2003/A1:2007	1 in 40	1 435 mm

**▼B**

Test condition number	Rail head profile	Rail inclination	Track gauge
6	Rail section 60 E 2 defined in EN 13674-1:2003/A1:2007	1 in 40	1 437 mm
7	Rail section 54 E1 defined in EN13674-12003	1 in 20	1 435 mm
8	Rail section 54 E1 defined in EN13674-12003	1 in 40	1 435 mm
9	Rail section 54 E1 defined in EN13674-12003	1 in 20	1 437 mm
10	Rail section 54 E1 defined in EN13674-12003	1 in 40	1 437 mm

The requirements of this clause are deemed to have been met by wheelsets having unworn S1002 or GV 1/40 wheel profiles, as defined in EN13715:2006 with spacing of active faces between 1 420 mm and 1 426 mm.

#### 4.2.3.4.3.2. IN-SERVICE VALUES OF WHEELSET EQUIVALENT CONICITY

In order to control rolling stock running stability, it is necessary to control the in-service values of the equivalent conicity. Target in-service values of wheelset conicity for interoperable rolling stock shall be defined together with target in-service values of the track conicity.

The 'in-service values of the track conicity' is an open point in the CR infrastructure TSI; therefore, the 'in-service values of wheelset conicity' is an open point in this TSI.

This clause is excluded from the assessment made by a notified body.

When a unit is operated on a given line, the equivalent conicity in-service values shall be maintained considering the specified limits for the unit (see clause 4.2.3.4.3) and local conditions of the network.

#### 4.2.3.5. Running gear

##### 4.2.3.5.1. Structural design of bogie frame

For units which include a bogie frame, the integrity of the structure of a bogie frame, all attached equipment and body to bogie connection shall be demonstrated based on methods as set out in clause 9.2 of EN 13749:2005. The design of the bogie shall be based on the information as specified in clause 7 of EN 13749:2005.

*Note:* A classification of the bogie according to clause 5 of EN 13749:2005 is not required.

In the application of the load cases referred to in the clauses of the standard mentioned above, the exceptional payload shall be taken as the 'design mass under exceptional payload' and the service (fatigue) load shall be taken as the 'design mass under normal payload' as set out in clause 4.2.2.10 of this TSI.



**▼ B**

The hypothesis taken to evaluate the loads due to bogie running (formulas and coefficients) in line with the standard EN 13749:2005 Annex C shall be justified and documented in the technical documentation described in clause 4.2.12.

## 4.2.3.5.2. Wheelsets

For the purpose of this TSI, wheelsets are defined to include main parts (axle and wheels) and accessories parts (axle bearings, axle boxes, gearboxes and brake discs). The wheelset shall be designed and manufactured with a consistent methodology using a set of load cases consistent with load conditions defined in clause 4.2.2.10 of this TSI.

## 4.2.3.5.2.1. MECHANICAL AND GEOMETRIC CHARACTERISTICS OF WHEELSETS

Mechanical behaviour of wheelsets:

The mechanical characteristics of the wheelsets shall ensure the safe movement of rolling stock.

The mechanical characteristics cover:

- assembly,
- mechanical resistance and fatigue characteristics.

The demonstration of compliance for assembly shall be based on EN13260:2009 clauses 3.2.1 and 3.2.2, which define limit values for the axial force and for fatigue, and associated verification tests.

Mechanical behaviour of axles:

In addition to the requirement on the assembly above, the demonstration of compliance for mechanical resistance and fatigue characteristics of the axle shall be based on EN13103:2009 clauses 4, 5 and 6 for non-powered axles, or EN13104:2009 clauses 4, 5 and 6 for powered axles.

The decision criteria for the permissible stress is specified in EN 13103:2009 clause 7 for non-powered axles, or EN 13104:2009 clause 7 for powered axles.

The fatigue characteristics of the axle (considering the design, the manufacturing process and the different critical axle areas) shall be verified by a fatigue type test of 10 million load cycles.

Verification of the manufactured axles:

A verification procedure shall exist to ensure at the production phase that no defects may decrease the mechanical characteristics of the axles.

The tensile strength of the material in the axle, the resistance to impact, the surface integrity, the material characteristics and the material cleanliness shall be verified.

The verification procedure shall specify the batch sampling used for each characteristic to be verified.

Mechanical behaviour of the axle boxes:

The axle box shall be designed with consideration of mechanical resistance and fatigue characteristics. Temperature limits reached in service shall be defined and recorded in the technical documentation described in clause 4.2.12 of this TSI.

Axle bearing condition monitoring is defined in clause 4.2.3.3.2 of this TSI.

**▼B**

Geometrical dimensions of wheelsets:

The geometric dimensions of the wheelsets, as defined in figure 1 shall be compliant with limit values specified in table 4. These limit values shall be taken as design values (new wheelset) and as in-service limit values (to be used for maintenance purposes; see also clause 4.5).

Table 4

**In-service limits of the geometric dimensions of wheelsets**

Designation	Wheel diameter D (mm)	Minimum value (mm)	Maximum value (mm)
Requirements linked to subsystem			
Front-to-front dimension ( $S_R$ ) (Distance between active faces) $S_R = A_R + S_d(\text{left wheel}) + S_d(\text{right wheel})$	$D > 840$	1 410	1 426
	$760 < D \leq 840$	1 412	
	$330 \leq D \leq 760$	1 415	
Back to back distance ( $A_R$ )	$D > 840$	1 357	1 363
	$760 < D \leq 840$	1 358	
	$330 \leq D \leq 760$	1 359	

The dimension  $A_R$  is measured at the height of the top of rail. The dimensions  $A_R$  and  $S_R$  shall be complied with in laden and tare conditions. Smaller tolerances within the above limits may be specified by the manufacturer in the maintenance documentation for in-service values.

Figure 1

**Symbols for wheelsets**

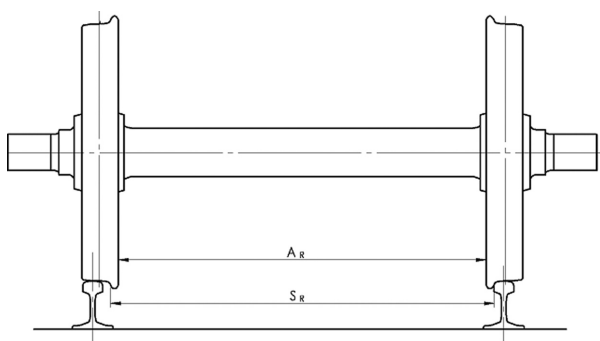

#### 4.2.3.5.2.2. MECHANICAL AND GEOMETRICAL CHARACTERISTICS OF WHEELS

The characteristics of the wheels ensure the safe movement of rolling stock and contribute to the guidance of the rolling stock.

Mechanical behaviour:

The mechanical characteristics of the wheel shall be proven by mechanical strength calculations, taking into account three load cases: straight track (centred wheelset), curve (flange pressed against the rail), and negotiating of points and crossings (inside surface of flange applied to the rail), as specified in EN 13979-1:2003 clauses 7.2.1 and 7.2.2.

**▼B**

For forged and rolled wheels, the decision criteria are defined in EN 13979-1:2003/A1:2009 clause 7.2.3; where the calculation show values beyond the decision criteria, a bench test according EN 13979-1:2003/A1:2009 clause 7.3 is required to be performed to demonstrate compliance.

For forged and rolled wheels, the fatigue characteristics (considering also the surface roughness) shall be verified by a fatigue type test of 10 million load cycles with a fatigue stress in the web of less than 450 MPa (for machined webs) and 315 MPa (for unmachined webs), with a probability of 99,7 %. The fatigue stress criteria are applicable to steel grades ER6, ER7, ER8 and ER9; for other steel grades the decision criteria shall be extrapolated from the known criteria of the other materials.

Other types of wheels are permitted for vehicles restricted to national use. In that case the decision criteria and the fatigue stress criteria shall be specified in national rules. Those national rules shall be notified by Member States in accordance with Article 3.

Thermo-mechanical behaviour:

If the wheel is used to brake a unit with blocks acting on the wheel running surface, the wheel shall be thermo mechanically proven by taking into account the maximum braking energy foreseen. A type test, as described in EN 13979-1:2003/A1:2009 clause 6.2 shall be performed in order to check that the lateral displacement of the rim during braking and the residual stress are within tolerance limits specified.

For forged and rolled wheels the decision criteria for residual stresses are specified for wheel material grades ER 6 and ER 7 in EN 13979-1:2003/A1:2009 clause 6.2.2; for other steel grades the decision criteria for residual stresses shall be extrapolated from the known criteria of the materials ER 6 and ER 7. A second test according to EN 13979-1:2003/A1:2009 clause 6.3 is permitted to be performed if the design residual stress is exceeded in the primary test. In this case, a field braking test according to EN 13979-1:2003/A1:2009 clause 6.4 shall also be performed.

Other types of wheels are permitted for vehicles restricted to national use. In that case the thermo-mechanical behaviour due to the use of brake blocks shall be specified in national rules. Those national rules shall be notified by Member States in accordance with Article 3.

Verification of the manufactured wheels:

A verification procedure shall exist to ensure at the production phase that no defects may decrease the mechanical characteristics of the wheels.

The tensile strength of the material in the wheel, the hardness of the running surface, the fracture toughness, resistance to impact, the material characteristics and the material cleanliness shall be verified.

The verification procedure shall specify the batch sampling used for each characteristic to be verified.

▼ B

Geometrical dimensions:

The geometrical dimensions of the wheels as defined in figure 2 shall be compliant with limit values specified in table 5. These limit values shall be taken as design values (new wheel) and as in-service limit values (to be used for maintenance purposes; see also clause 4.5).

Table 5

**In-service limits of the geometric dimensions of wheel**

Designation	Wheel diameter D (mm)	Minimum value (mm)	Maximum value (mm)
Width of the rim ( $B_R$ + Burr)	$D \geq 330$	133	145
Thickness of the flange ( $S_d$ )	$D > 840$	22	33
	$760 < D \leq 840$	25	
	$330 \leq D \leq 760$	27,5	
Height of the flange ( $S_h$ )	$D > 760$	27,5	36
	$630 < D \leq 760$	29,5	
	$330 \leq D \leq 630$	31,5	
Face of flange ( $q_R$ )	$\geq 330$	6,5	

Figure 2

**Symbols for wheels**

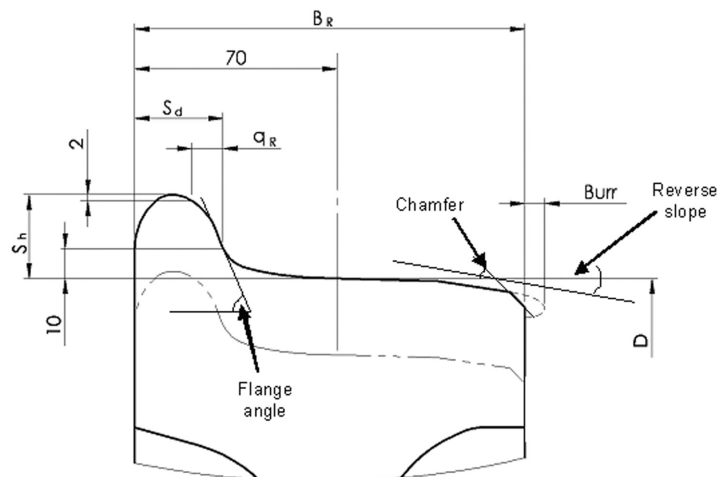

Units equipped with independently rotating wheels shall, in addition to the requirements in this clause dealing with wheels, meet the requirements in this TSI for geometrical characteristics of wheelsets defined in clause 4.2.3.5.2.1.

#### 4.2.3.5.2.3. VARIABLE GAUGE WHEELSETS

This requirement is applicable to units equipped with variable gauge wheelsets with changeover between the European standard nominal track gauge and another track gauge.

**▼B**

The changeover mechanism of the wheelset shall ensure the safe locking in the correct intended axial position of the wheel.

External visual verification of the state of the locking system (locked or unlocked) shall be possible.

If the wheelset is equipped with brake equipment, the position and locking in the correct position of this equipment shall be ensured.

The conformity assessment of the requirements specified in this clause is an open point.

#### 4.2.3.6. Minimum curve radius

The minimum curve radius to be negotiated shall be:

— 150 m for all units

#### 4.2.3.7. Life guards

This requirement applies to units fitted with a driving cab.

The wheels shall be protected against damages caused by minor items on the rails. This requirement can be met by life guards in front of the wheels of the leading axle.

The height of the lower end of the life guard above the plain rail shall be:

— 30 mm minimum in all conditions,

— 130 mm maximum in all conditions,

taking into account in particular wheel wear and suspension compression.

If an obstacle deflector specified in clause 4.2.2.5 has its lower edge at less than 130 mm above the plain rail in all conditions, it fulfils the functional requirement of the life guards and therefore it is permissible not to fit life guards.

A life guard shall be designed to withstand a minimum longitudinal force without permanent deformation of 20 kN. This requirement shall be verified by a calculation.

A life guard shall be designed so that, during plastic deformation, it does not foul the track or running gear and that contact with the wheel tread, if it occurs, does not pose a risk of derailment.

#### 4.2.4. Braking

##### 4.2.4.1. General

The purpose of the train braking system is to ensure that the train's speed can be reduced or maintained on a slope, or that the train can be stopped within the maximum allowable braking distance. Braking also ensures the immobilisation of a train.

The primary factors that influence the braking performance are the braking power (braking force production), the train mass, the train rolling resistance, the speed, the available adhesion.

Individual unit performance for units operated in various train formations is defined so that the overall braking performance of the train can be derived.

The braking performance is determined by deceleration profiles (deceleration = F (speed) and equivalent response time).

**▼ B**

Stopping distance, brake weight percentage (also called ‘lambda’ or ‘braked mass percentage’), braked mass are also used, and can be derived (directly or via stopping distance) from deceleration profiles by a calculation.

The braking performance could vary with the load of the train or vehicle.

The minimum train braking performance required to operate a train on a line at an intended speed is dependent on the line characteristics (signalling system, maximum speed, gradients, line safety margin) and is a characteristic of the infrastructure.

The train or vehicle main data characterising the braking performance is defined in the clause 4.2.4.5 of this TSI.

This interface between Infrastructure and Rolling stock is covered by the clause 4.2.2.6.2 of the CR OPE TSI.

#### 4.2.4.2. Main functional and safety requirements

##### 4.2.4.2.1. Functional requirements

The following requirements apply to all units.

Units shall be equipped with:

- a main brake function used during operation for service and emergency braking,
- a parking brake function used when the train is parked, allowing the application of a brake force without any available energy on board for an unlimited period of time.

The main brake system of a train shall be:

- continuous: the brake application signal is transmitted from a central command to the whole train by a control line,
- automatic: an inadvertent disruption (loss of integrity) of the control line leads to brake activation on all vehicles of the train.

The main brake function may be complemented by additional brake systems described in clause 4.2.4.7 (dynamic brake — braking system linked to traction system) and/or clause 4.2.4.8 (braking system independent of adhesion conditions).

The dissipation of the braking energy shall be considered in the design of the braking system, and shall not cause any damage to the components of the braking system in normal operation conditions; this shall be verified by a calculation as specified in clause 4.2.4.5.4 of this TSI.

The temperature reached around the brake components shall also be considered in the design of the rolling stock.

The design of the brake system shall include means for monitoring and tests as specified in clause 4.2.4.9 of this TSI.

The requirements below in this clause 4.2.4.2.1 apply to units that can be operated as a train.

**▼ B**

The braking performance shall be ensured in consistence with safety requirements expressed in clause 4.2.4.2.2 in case of inadvertent disruption of the brake control line, and in the event of the braking energy supply being disrupted, the power supply failing or other energy source failure.

In particular, there shall be sufficient braking energy available on board the train (stored energy), distributed along the train consistent with the design of the brake system, to ensure the application of the required brake forces.

Successive applications and releases of the brake shall be considered in the design of the braking system (inexhaustibility).

In case of unintentional train separation, the two parts of the train shall be brought to a standstill; the braking performances on the two parts of the train are not required to be identical to the braking performance in normal mode.

In the event of the braking energy supply being disrupted or the power supply failing, it shall be possible to hold in a stationary position a unit with maximum load (design mass under exceptional payload) on a 35‰ gradient by using the friction brake of the main brake system alone, for at least two hours.

The unit braking control system shall have three control modes:

- emergency braking: application of a predefined brake force in the shortest time in order to stop the train with a defined level of brake performance,
- service braking: application of an adjustable brake force in order to control the speed of the train, including stop and temporary immobilisation,
- parking braking: application of a brake force to maintain the train (or the vehicle) in permanent immobilisation in a stationary position, without any available energy on board.

A brake application command, whatever its control mode, shall take control of the brake system, even in case of active brake release command; this requirement is permitted not to apply when intentional suppression of the brake application command is given by the driver (e.g. passenger alarm override, uncoupling ...).

For speeds higher than 5 km/h, the maximum jerk due to the use of brakes shall be lower than 4 m/s<sup>3</sup>.

The jerk behaviour may be derived from the calculation and from the evaluation of the deceleration behaviour as measured during the brake tests.

#### 4.2.4.2.2. Safety requirements

The braking system is the means to stop a train, and therefore contributes to the safety level of the railway system.

- In particular, the emergency braking system and performance are rolling stock characteristics used by the CCS subsystem.

**▼B**

The functional requirements expressed in clause 4.2.4.2.1 contribute to ensure safe functioning of the braking system; nevertheless, a risk approach is necessary to evaluate the braking performance, as many components are involved.

The hazards considered, and the corresponding safety requirements that shall be met are expressed in the table 6 below.

Table 6

**Braking system — safety requirements**

	Hazard	Safety requirement to be met	
		Severity/Consequence to be prevented	Minimum allowable number of combinations of failures
No 1	Applies to units fitted with a cab (brake command)		
	After activation of an emergency brake command no deceleration of the train due to failure in the brake system (complete and permanent loss of the brake force).  <i>Note:</i> Activation by the driver or by the CCS system to be considered. Activation by passengers (alarm) not considered.	Catastrophic	2 (no single failure is accepted)
No 2	Applies to units equipped with traction equipment		
	After activation of an emergency brake command, no deceleration of the train due to failure in the traction system (Traction force $\geq$ Brake force).	Catastrophic	2 (no single failure is accepted)
No 3	Applies to all units		
	After activation of an emergency brake command, the stopping distance is longer than the one in normal mode due to failure(s) in the brake system.  <i>Note:</i> The performance in the normal mode is defined in clause 4.2.4.5.2.	NA	Single failures leading to an increase of the stopping distance of more than 5 % shall be identified, and the increase of the stopping distance shall be determined
No 4	Applies to all units		
	After activation of a parking brake command, no parking brake force applied (complete and permanent loss of the parking brake force).	NA	2 (no single failure is accepted)



**▼B**

The ‘catastrophic consequence’ is defined in CSM, Article 3(23).

Additional brake systems shall be considered in the safety study under the conditions specified in clauses 4.2.4.7 and 4.2.4.8.

#### 4.2.4.3. Type of brake system

Units designed and assessed to be operated in general operation (various formations of vehicles from different origins; train formation not defined at design stage) shall be fitted with a brake system with a brake pipe compatible with the UIC brake system. To this end, the clause 5.4 ‘UIC brake system’ of the standard EN 14198:2004 ‘Requirements for the brake system of trains hauled by a locomotive’ specifies the principles to be applied.

This requirement is set to ensure technical compatibility of the brake function between vehicles of various origins in a train.

There is no requirement on the type of brake system for units (trainsets or vehicles) assessed in fixed or predefined formation.

#### 4.2.4.4. Brake command

##### 4.2.4.4.1. Emergency braking command

This clause applies to units fitted with a driver’s cab.

At least two independent emergency brake command devices shall be available, allowing the activation of the emergency brake by a simple and single action from the driver in his normal driving position, using one hand.

The sequential activation of these two devices may be considered in the demonstration of compliance to the safety requirement No 1 of table 6 of clause 4.2.4.2.2.

One of these devices shall be a red punch button (mushroom push button).

The emergency brake position of these two devices when activated shall be self locking by a mechanical device; unlocking this position shall be possible only by an intentional action.

The activation of the emergency brake shall also be possible by the Control-Command and signalling onboard system, as defined in the CR CCS TSI.

Unless the command is cancelled, the emergency brake activation shall lead permanently, automatically and in less than 0.25 seconds to the following actions:

- transmission of an emergency brake command along the train by the brake control line at a defined transmission speed, which shall be higher than 250 metres/second,
- cut-off of all tractive effort in less than 2 second; this cut-off shall not be able to be reset until the traction command is cancelled by the driver,
- a inhibition of all ‘release brake’ commands or actions.

**▼B**

## 4.2.4.4.2. Service braking command

This clause applies to units fitted with a driver's cab.

The service brake function shall allow the driver to adjust (by application or release) the brake force between a minimum and a maximum value in a range of at least 7 steps (including brake release and maximum brake force), in order to control the speed of the train.

Only one service braking command shall be active in a train. To meet this requirement, it shall be possible to isolate the service braking function of the other service braking command(s) of the unit(s) part of a train formation, as defined for fixed and predefined formations.

When the speed of the train is higher than 15 km/h, the service brake activation shall lead automatically to the cut-off of all tractive effort; this cut-off shall not be reset until the traction command is cancelled by the driver.

*Note:* A friction brake may be used intentionally at speed higher than 15 km/h with traction for specific purpose (de-icing, cleaning of brake components ...); it shall not be possible to use these particular functionalities in case of service brake activation.

## 4.2.4.4.3. Direct braking command

Locomotives (units designed to haul freight wagons or passenger carriages) assessed for general operation shall be fitted with a direct brake system.

The direct brake system shall allow the application of a brake force on the concerned unit(s) only, with other unit(s) of the train remaining without brake applied.

## 4.2.4.4.4. Dynamic braking command

If a unit is equipped with a dynamic brake system:

— It shall be possible for the driver to prevent the use of regenerative braking on electric units so that there is no return of energy to the overhead contact line when driving on a line which does not allow that (see CR ENE TSI clause 4.2.7).

See also clause 4.2.8.2.3 for regenerative brake.

— It is permitted to use a dynamic brake independently from other brake systems, or together with other brake systems (blending).

## 4.2.4.4.5. Parking braking command

This clause applies to all units.

The parking braking command shall lead to the application of a defined brake force for an unlimited period of time, during which a lack of any energy on board may occur.

It shall be possible to release the parking brake at standstill in any situation, including for rescue purposes.

**▼ B**

For units assessed in fixed or pre-defined formations, and for locomotives assessed for general operation, the parking brake command shall be activated automatically when the unit is switched off.

For other units, the parking brake command shall be either activated manually, or activated automatically when the unit is switched off.

*Note:* The application of the parking brake force may depend on the service brake status; it shall be effective when the energy on board to apply the service brake is going to decrease or is lost.

#### 4.2.4.5. Braking performance

##### 4.2.4.5.1. General requirements

The unit (trainset or vehicle) braking performance (deceleration =  $F(\text{speed})$  and equivalent response time) shall be determined by calculation as defined in the standard EN14531-6:2009, considering a level track.

Each calculation shall be performed for wheel diameters corresponding to new, half-worn and worn wheels, and shall include the calculation of the required wheel rail adhesion level (see clause 4.2.4.6.1).

The friction coefficients used by friction brake equipments and considered in the calculation shall be justified (see standard EN14531-1:2005 clause 5.3.1.4).

The braking performance calculation shall be performed for the two control modes: emergency brake and maximum service brake.

The braking performance calculation shall be performed at design stage, and shall be revised (correction of parameters) after the physical tests required in the clauses 6.2.2.2.5 and 6.2.2.2.6, in order to be consistent with test results.

The final braking performance calculation (consistent with test results) shall be part of the technical documentation specified in clause 4.2.12.

The maximum average deceleration developed with all brakes in use, including the brake independent of wheel/rail adhesion, shall be lower than  $2,5 \text{ m/s}^2$ ; this requirement is linked to the longitudinal resistance of the track (interface with infrastructure; see CR INF TSI clause 4.2.7.2).

##### 4.2.4.5.2. Emergency braking

Response time:

For units assessed in fixed formation(s) or pre-defined formation(s), the equivalent response time(\*) and the delay time(\*) evaluated on the total emergency braking force developed in case of the emergency brake command shall be lower than the following values:

— Equivalent response time: 5 seconds

— Delay time: 2 seconds

(\*) definition according to EN 14531-1:2005 clause 5.3.3.

**▼B**

For units designed and assessed for general operation, the response time shall be as specified for the UIC brake system (see also clause 4.2.4.3: the brake system shall be compatible with the UIC brake system).

Calculation of the deceleration:

For all units, the emergency braking performance calculation shall be performed in accordance with standard EN 14531-6:2009; the deceleration profile and stopping distances at the following initial speeds (if lower than the maximum speed): 30 km/h; 80 km/h; 120 km/h; 140 km/h; 160 km/h; 200 km/h shall be determined.

The standards EN 14531-1:2005 clause 5.12 specifies how other parameters (brake weight percentage ( $\lambda$ ), braked mass) can be derived from the calculation of the deceleration or from the stopping distance of the unit.

For units designed and assessed for general operation, the brake weight percentage ( $\lambda$ ) shall also be determined.

The emergency braking performance calculation shall be performed with a brake system in two different modes:

- Normal mode: no failure in the brake system and nominal value of the friction coefficients (corresponding to dry conditions) used by friction brake equipment. This calculation provides the braking performance normal mode.
- Degraded mode: corresponding to the failures considered in clause 4.2.4.2.2, hazard No 3, and nominal value of the friction coefficients used by friction brake equipment. Degraded mode shall consider possible single failures; to that end, the emergency braking performance shall be determined for the case of single point failures leading to an increase of the brake distance of more than 5 %, and the associated single failure shall be clearly identified (component involved and failure mode, failure rate if available).
- Degraded conditions: In addition, the emergency braking performance calculation shall be performed with reduced values of the friction coefficient, with consideration of limit values for temperature and humidity (see standard EN14531-1:2005 clause 5.3.1.4).

*Note:* These different modes and conditions have to be considered particularly when advanced control command and signalling systems (such as ETCS) are implemented, aiming at optimising the railway system.

The emergency braking performance calculation shall be performed for the three load conditions defined in clause 4.2.2.10 as:

- minimum load: ‘design mass in working order’,
- normal load: ‘design mass under normal payload’,
- maximum load: ‘design mass under exceptional payload’.

**▼B**

For each load condition, the lowest result (i.e. leading to longest stopping distance) of the 'emergency braking performance in normal mode' calculations at the design maximum speed (revised according to the results of tests required below) shall be recorded in the rolling stock register defined in clause 4.8 of this TSI.

**4.2.4.5.3. Service braking**

Calculation of the deceleration:

For all units, the service braking performance calculation shall be performed in accordance with standard EN 14531-6:2009 with a brake system in normal mode, with nominal value of the friction coefficients used by friction brake equipment for the load condition 'design mass under normal payload' at the design maximum speed.

Maximum service braking performance:

When the service braking has higher design performance capability than the emergency braking, it shall be possible to limit the maximum service braking performance (by design of the braking control system, or as a maintenance activity) at a level lower than the emergency braking performance.

*Note:* A Member State may ask the emergency braking performance to be at a higher level than the maximum service braking performance for safety reasons, but in any case it cannot prevent the access to a railway undertaking using a higher maximum service braking performance, unless that Member State is able to demonstrate that the national safety level is endangered.

**4.2.4.5.4. Calculations related to thermal capacity**

This clause applies to all units.

For OTMs, it is allowed to verify this requirement by temperature measurements on wheels and brake equipment.

The brake energy capacity shall be verified by calculation showing that the braking system is designed to withstand the dissipation of the braking energy. The reference values used in this calculation for the components of the braking system that dissipate energy shall either be validated by a thermal test or by previous experience.

This calculation shall include the scenario consisting of 2 successive emergency brake applications from the maximum speed (time interval corresponding to the time needed to accelerate the train up to the maximum speed) on level track for the load condition 'design mass under exceptional payload'.

In case of unit that cannot be operated alone as a train, the time interval between 2 successive emergency brake applications used in the calculation shall be reported.

**▼B**

The maximum line gradient, associated length and operating speed for which the brake system is designed in relation with brake thermal energy capacity shall also be defined by a calculation for the load condition 'design mass under exceptional payload', with the service brake being used to maintain the train at a constant operating speed.

The result (maximum line gradient, associated length and operating speed) shall be recorded in the rolling stock register defined in clause 4.8 of this TSI.

The following 'reference case' for the slope to be considered is suggested: maintain the speed of 80 km/h on a slope of 21 ‰ constant gradient over a distance of 46 km. If this reference case is used, the rolling stock register shall only mention the compliance to it.

#### 4.2.4.5.5. Parking brake

Performance:

A unit (train or vehicle) in load condition 'design mass in working order' without any power supply available, and stationary permanently on a 35 ‰ gradient, shall be kept immobilised.

Immobilisation shall be achieved by means of the parking brake function, and additional means (e.g. scotches) in case where the parking brake is unable to achieve the performance on its own; the required additional means shall be available on board the train.

Calculation:

The unit (train or vehicle) parking brake performance shall be calculated as defined in the standard EN14531-6:2009. The result (gradient where the unit is kept immobilised by the parking brake alone) shall be recorded in the rolling stock register defined in clause 4.8 of this TSI.

#### 4.2.4.6. Wheel rail adhesion profile — Wheel slide protection system

##### 4.2.4.6.1. Limit of wheel rail adhesion profile

The braking system of a unit shall be designed so that the service brake performance without dynamic brake and the emergency brake performance do not assume a calculated wheel/rail adhesion in the speed range > 30 km/h higher than the following values:

- 0,15 for locomotives, for units designed to carry passengers assessed for general operation, and for units assessed in fixed or pre-defined formation(s) having more than 7 and less than 16 axles,
- 0,13 for units assessed in fixed or pre-defined formation(s) having 7 axles or less,

**▼ B**

- 0,17 for units assessed in fixed or pre-defined formation(s) having 20 axles or more. This minimum number of axles may be reduced to 16 axles if the test required in Section 4.2.4.6.2 related to the efficiency of the WSP system provides positive result; otherwise 0,15 shall be used as limited value of wheel rail adhesion between 16 and 20 axles.

The above requirement shall also apply for a direct brake command described in clause 4.2.4.4.3.

The design of a unit shall not assume wheel/rail adhesion higher than 0,12 when calculating the parking brake performance.

These limits of wheel rail adhesion shall be verified by calculation with the smallest wheel diameter, and with the 3 load conditions considered in clause 4.2.4.5.

All values of adhesion shall be rounded to two decimal places.

#### 4.2.4.6.2. Wheel slide protection system

A wheel slide protection system (WSP) is a system designed to make the best use of available adhesion by a controlled reduction and restoration of the brake force to prevent wheelsets from locking and uncontrolled sliding, thereby minimising the extension of stopping distances and possible wheel damage.

Requirements on the presence and use of a WSP system on the unit:

- Units designed for maximum service speed higher than 150 km/h shall be fitted with a wheel slide protection system.
- Units equipped with brake blocks on wheel running surface with a brake performance which assumes a calculated wheel/rail adhesion higher than 0,12 shall be fitted with a wheel slide protection system.

Units not equipped with brake blocks on wheel running surface with a brake performance which assumes a calculated wheel/rail adhesion higher than 0,11 shall be fitted with a wheel slide protection system.

- The requirement on the wheel slide protection system above shall apply to the two brake modes: emergency brake and service brake.

It shall also apply to the dynamic brake system, which is part of the service brake, and can be part of the emergency brake (see clause 4.2.4.7).

Requirements on the WSP system performance:

- For units equipped with a dynamic braking system, a WSP system (if present according to the point above) shall control the dynamic brake force; when this WSP system is not available, the dynamic brake force shall be inhibited, or limited in order not to lead a wheel/rail adhesion demand higher than 0,15.

**▼B**

- The wheel slide protection system shall be designed according to EN 15595:2009 clause 4, and verified according to the methodology defined in EN 15595:2009 clauses 5 and 6; when reference is made to the clause 6.2 of EN 15595:2009 ‘overview of required test programmes’, only the clause 6.2.3 applies, and it applies to all types of units.

If a unit is equipped with a WSP, a test shall be done to verify the efficiency of the WSP system (maximum extension of the stopping distance compared to stopping distance on dry rail) when integrated in the unit.

The relevant components of the wheel slide protection system shall be considered in the safety analysis of the emergency brake function required in clause 4.2.4.2.2.

#### 4.2.4.7. Dynamic brake — Braking system linked to traction system

Where the braking performance of the dynamic brake or of braking system linked to the traction system is included in the performance of the emergency braking in normal mode defined in clause 4.2.4.5.2, the dynamic brake or the braking system linked to traction shall be:

- commanded by the main brake system control line (see clause 4.2.4.2.1),
- included in the safety analysis required by the safety requirement No 3 set out in clause 4.2.4.2.2 for the emergency brake function,
- subject to a safety analysis covering the hazard ‘after activation of an emergency command, complete loss of the brake force’.

*Note:* For electric units, this analysis shall cover failures leading to absence onboard the unit of the voltage delivered by the external power supply.

#### 4.2.4.8. Braking system independent of adhesion conditions

##### 4.2.4.8.1. General

Brake systems able to develop a brake force applied on the rail, independent of the wheel/rail adhesion condition, are a means of providing additional braking performance when the requested performance is higher than the performance corresponding to the limit of the available wheel rail adhesion (see clause 4.2.4.6).

It is permissible to include the contribution of brakes independent of wheel/rail adhesion in the braking performance in normal mode defined in clause 4.2.4.5 for the emergency brake; in such a case, the brake system independent of adhesion condition shall be:

- commanded by the main brake system control line (see clause 4.2.4.2.1),
- included in the safety analysis required by the safety requirement No 3 set out in clause 4.2.4.2.2 for the emergency brake function,
- subject of a safety analysis covering the hazard ‘after activation of an emergency command, complete loss of the brake force’.



**▼B**

## 4.2.4.8.2. Magnetic track brake

Requirements on magnetic brakes specified by the CCS subsystem are referenced in clause 4.2.3.3.1 of this TSI.

A magnetic track brake is allowed to be used as an emergency brake, as mentioned in the CR INF TSI, clause 4.2.7.2.

The geometrical characteristics of the end elements of the magnet in contact with the rail shall be as specified for one of the types described in Appendix 3 of UIC 541-06:Jan 1992.

## 4.2.4.8.3. Eddy current track brake

This section covers only eddy current track brake developing a brake force between the rolling stock and the rail.

Requirements on eddy current track brakes specified by the CCS subsystem are referenced in clause 4.2.3.3.1 of this TSI.

According to the CR INF TSI, clause 4.2.7.2, the conditions for use of eddy current track brake are not harmonised.

Therefore, requirements to be met by eddy current track brake are an open point.

## 4.2.4.9. Brake state and fault indication

Information available to train staff shall allow the identification of degraded conditions concerning the rolling stock (brake performance lower than the performance required), for which specific operating rules apply.

To that end, it shall be possible at certain phases during operation for the train staff to identify the status (applied or released or isolated) of the main (emergency and service) and parking brake systems, and the status of each part (including one or several actuators) of these systems that can be controlled and/or isolated independently.

If the parking brake always depends directly on the state of main brake system, it is not required to have an additional and specific indication for the parking brake system.

The phases that shall be considered during operation are standstill and running.

When at a standstill, train staff shall be able to check from inside and/or outside of the train:

— the continuity of the train brake control command line,

— the availability of the braking energy supply along the train,

**▼B**

- the status of the main brake and parking brake systems and the status of each part (including one or several actuators) of these systems that can be controlled and/or isolated separately (as described above in the first paragraph of this clause), excepted for dynamic brake and braking system linked to traction systems.

When running, the driver shall be able to check from the driving position in the cab:

- the status of the train brake control command line,
- the status of the train brake energy supply,
- the status of the dynamic brake and braking system linked to traction system if it is taken into account in the brake performance,
- the status applied or released of at least one part (actuator) of the main brake system which is controlled independently (e.g. a part which is installed on the vehicle fitted with an active cab).

The function providing the information described above to the train staff is a safety related function, as it is used for the train staff to evaluate the braking performance of the train. Where local information is provided by indicators, the use of harmonised indicators ensures the required safety level. Where a centralised control system allowing the train staff to perform all checks from one location (i.e. inside the drivers cab) is provided, the safety level for this control system is an open point.

Applicability to units intended for general operation:

Only functionalities that are relevant to the design characteristics of the unit (e.g. presence of a cab, ...) shall be considered.

The signals transmission required (if any) between the unit and the other coupled unit(s) in a train for the information regarding the brake system to be available at train level shall be documented, taking into account functional aspects.

This TSI does not impose any technical solution regarding physical interfaces between units.

#### 4.2.4.10. Brake requirements for rescue purposes

All brakes (emergency, service, parking) shall be fitted with devices allowing their release and isolation. These devices shall be accessible and functional whether the train or vehicle is: powered, non-powered or immobilised without any available energy on board.

It shall be possible to rescue a train with no energy available on board by a rescue power unit equipped with a pneumatic brake system compatible with the UIC brake system (brake pipe as braking control command line), and to have a part of the brake system of the rescued train controlled by means of an interface device.

**▼ B**

*Note:* See clause 4.2.2.2.4 of this TSI for mechanical interface.

The braking performance developed by the rescued train in this particular operating mode shall be evaluated by a calculation, but is not required to be the same as the braking performance described in clause 4.2.4.5.2. The calculated braking performance shall be part of the technical documentation specified in clause 4.2.12.

This requirement does not apply to units which are operated in a train formation of less than 200 tons (load condition 'design mass in working order').

#### 4.2.5. *Passenger related items*

For information purposes only, the following non-exhaustive list gives an overview of the basic parameters covered by the PRM TSI, which are applicable to conventional units which are intended to carry passengers:

- seats, including priority seats,
- wheelchair spaces,
- exterior doors, including dimensions, obstacle detectors, controls,
- interior doors, including controls, dimensions,
- toilets,
- clearways,
- lighting,
- customer information,
- floor height changes,
- handrails,
- wheelchair Accessible sleeping accommodation,
- step position for vehicle access and egress, including steps and boarding aids.

Additional requirements are specified below in this clause.

The passenger related parameters which are specified in the SRT TSI clauses 4.2.5.7 (Communication means on trains) and 4.2.5.8 (Emergency brake override), differ from some of the requirements in the present TSI. For this, the TSIs shall be applied as follows:

- SRT TSI clause 4.2.5.7 (Communication means on trains) shall be substituted by clause 4.2.5.2 (Public address system: audible communication system) of the present TSI for conventional rolling stock.
- SRT TSI clause 4.2.5.8 (Emergency brake override) shall be substituted by 4.2.5.3 (Passenger alarm: functional requirements) of the present TSI for conventional rolling stock.

*Note:* Refer to clause 4.2.10.1.3 of the present TSI for other interface information between the present TSI and the SRT TSI.

**▼B**

## 4.2.5.1. Sanitary systems

If a water tap is provided in a unit and unless the water is provided from the tap in accordance with the Drinking water Directive (Council Directive 98/83/EC <sup>(1)</sup>) a visual sign shall clearly indicate that the water provided at the tap is not drinkable.

Sanitary systems (toilets, washrooms, bar/restaurant facilities) where fitted shall not allow the release of any material that may be detrimental to the health of people or to the environment.

Released materials (treated water) shall be conformant to the applicable European regulations under the Water Framework Directive:

- The bacterial content of water discharged from sanitary systems shall not at any time exceed the bacterial content value for Intestinal enterococci and *Escherichia coli* bacteria specified as 'good' for inland waters in European Directive 2006/7/EC of the European Parliament and of the Council <sup>(2)</sup> concerning the management of bathing water quality.
- The treatment processes shall not introduce substances that are identified in annex I of Directive 2006/11/EC of the European Parliament and of the Council <sup>(3)</sup> on pollution caused by certain dangerous substances discharged into the aquatic environment of the Community.

To limit the dispersion of released liquid on the trackside, uncontrolled discharge from any source shall take place downwards only, under the body frame of the vehicle in a distance not greater than 0,7 metres from the longitudinal centre line of the vehicle.

The following shall be provided in the technical documentation described in clause 4.2.12:

- the presence and type of toilets in a unit,
- the characteristics of the flushing medium, if it is not clean water,
- the nature of the treatment system for released water and the standards against which conformity has been assessed.

## 4.2.5.2. Public address system: audible communication system

*This clause shall substitute SRT TSI clause 4.2.5.7 (Communication means on trains) for conventional rolling stock.*

This clause applies to all units designed to carry passengers and units designed to haul passenger trains.

Trains shall be equipped as a minimum with a means of audible communication:

- for the train crew to address the passengers in a train,
- for the train crew and ground control to communicate between each other.

<sup>(1)</sup> OJ L 330, 5.12.1998, p. 32.

<sup>(2)</sup> OJ L 64, 4.3.2006, p. 37.

<sup>(3)</sup> OJ L 64, 4.3.2006, p. 52.

**▼ B**

*Note:* The specification and assessment of this function are part of the CR CCS TSI, clause 4.2.4 'EIRENE functions',

- for internal communication between the train crew and in particular between the driver and staff in the passenger area (if any).

The equipment shall be able to remain on standby independently of the main energy source for at least three hours. During the standby time the equipment shall be able to actually function at random intervals and periods during an accumulated time of 30 minutes.

The communication system shall be designed in such a manner that it continues to operate at least half (distributed throughout the train) of its loudspeakers in the event of a failure in one of its transmission elements or, as an alternative, another means shall be available to inform the passengers in the event of a failure.

Provisions for passengers to contact train crew are prescribed in clause 4.2.5.3 (passenger alarm) and 4.2.5.5 (communication devices for passengers).

Applicability to units intended for general operation:

Only functionalities that are relevant to the design characteristics of the unit (e.g. presence of a cab, of a crew interface system, ...) shall be considered.

The signals transmission required between the unit and the other coupled unit(s) in a train for the communication system to be available at train level shall be implemented and documented, taking into account functional aspects.

This TSI does not impose any technical solution regarding physical interfaces between units.

#### 4.2.5.3. Passenger alarm: functional requirements

*This clause shall substitute SRT TSI clause 4.2.5.8 (Emergency brake override) for conventional rolling stock.*

This clause is applicable to all units designed to carry passengers and units designed to haul passenger trains.

The passenger alarm is a safety related function, for which the requirements, including safety aspects, are set out in this clause.

General requirements:

The passenger alarm shall comply either:

- (a) with the HS RST TSI 2008 clause 4.2.5.3;
- (b) or alternatively, with the provisions described below, which then replace the provisions of the HS RST TSI 2008 for application to units in the scope of this CR LOC & PAS TSI.

**▼ B**

Alternative provisions for the passenger alarm:

Requirements for information interfaces:

- With the exception of toilets and gangways, each compartment, each entrance vestibule and all other separated areas intended for passengers shall be equipped with at least one clearly visible and indicated alarm device to inform the driver in the event of a danger.
- The alarm device shall be designed so that once activated it cannot be cancelled by passengers.
- At the triggering of the passenger alarm, both visual and acoustic signs shall indicate to the driver that one or more passenger alarms have been activated.
- A device in the cab shall allow the driver to acknowledge his awareness of the alarm. The driver's acknowledgement shall be perceivable at the place where the passenger alarm was triggered and shall stop the acoustic signal in the cab.
- On the driver's initiative, the system shall allow a communication link to be established between the driver's cab and the place where the alarm(s) was/were triggered. The system shall allow the driver to cancel this communication link on his initiative.
- A device shall enable the crew to reset the passenger alarm.

Requirements for activation of the brake by the passenger alarm:

- When the train is stopped at a platform or departing from a platform, activation of a passenger alarm shall lead to a direct application of the service brake or the emergency brake, resulting in a complete stop. In this case, only after the train has come to a complete stop, system shall allow the driver to cancel any automatic braking action initiated by the passenger alarm.
- In other situations, 10 +/- 1 seconds after activation of the (first) passenger alarm, at least an automatic service brake shall be initiated unless the passenger alarm is acknowledged by the driver within this time. The system shall allow the driver to override at any time an automatic braking action initiated by the passenger alarm.

Criteria for a train departing from a platform:

A train is deemed to be departing from a platform during the period of time elapsing between the moment when door status is changed from 'released' to 'closed and locked' and the moment when the last vehicle has left the platform.

This moment shall be detected by an onboard device. If the platform is not physically detected, the train is deemed to have left the platform when:

- the speed of the train reaches 15 (+/- 5) km/h, or:
- the distance covered is 100 (+/- 20) m,

**▼B**

whichever occurs the first.

Safety requirements:

The passenger alarm is considered to be a safety related function, for which the required safety level is deemed to be satisfied by the following requirements:

- A control system shall permanently monitor the ability of the passenger alarm system to convey the signal.

As alternative, a passenger alarm system with no control system (as described in this bullet point) shall be accepted if it is demonstrated to be compliant with the required safety level; the value of the required safety level is an open point.

- Units fitted with a driver's cab shall be fitted with a device which allows authorised staff to isolate the passenger alarm system.
- If the passenger alarm system is not functioning, either after intentional isolation by staff, due to a technical failure, or by coupling the unit with a non-compatible unit, application of the passenger alarm shall result in a direct application of brakes. In this case, the provisions to enable the driver to override the brake is not mandatory.
- If the passenger alarm system is not functioning, this shall be permanently indicated to the driver in the active driver's cab.

A train with an isolated passenger alarm system does not meet the minimum requirements for safety and interoperability as defined in this TSI and shall therefore be regarded to as being in degraded mode.

Applicability to units intended for general operation:

Only functionalities that are relevant to the design characteristics of the unit (e.g. presence of a cab, of a crew interface system, ...) shall be considered.

The signals transmission required between the unit and the other coupled unit(s) in a train for the passenger alarm system to be available at train level shall be implemented and documented, taking into account functional aspects; it shall be compatible with both solutions (a) and (b) mentioned under 'General requirements'.

This TSI does not impose any technical solution regarding physical interfaces between units.

#### 4.2.5.4. Safety instructions to passengers — Signs

This clause is applicable to all units designed to carry passengers.

Instructions shall be given to passengers on the use of emergency exits, the activation of passenger alarm, about passenger doors locked out of service, etc. These instructions shall be given according to the provisions of the PRM TSI clauses 4.2.2.8.1 and 4.2.2.8.2.

**▼ B**

## 4.2.5.5. Communication devices for passengers

This clause applies to all units designed to carry passengers and units designed to haul passenger trains.

Units designed for operation without staff onboard (other than driver) shall be equipped with a 'call for aid' device for passengers to communicate to the driver in case of emergency. In this case the system shall allow the communication link to be established on the initiative of the passenger. The system shall allow the driver to cancel this communication link at his initiative. The requirements to the position of the 'call for aid' device are the ones applicable for the passenger alarm as defined in clause 4.2.5.3 'Passenger alarm: functional requirements'.

The 'call for aid' devices shall be compliant with the information and indication requirements as set out for the 'Emergency call device' in the PRM TSI clause 4.2.2.8.2.2 'Interoperable constituent requirements'.

Applicability to units intended for general operation:

Only functionalities that are relevant to the design characteristics of the unit (e.g. presence of a cab, of a crew interface system, ...) shall be considered.

The signals transmission required between the unit and the other coupled unit(s) in a train for the communication system to be available at train level shall be implemented and documented, taking into account functional aspects.

This TSI does not impose any technical solution regarding physical interfaces between units.

## 4.2.5.6. Exterior doors: passenger access to and egress from rolling stock

This clause applies to all units designed to carry passengers and units designed to haul passenger trains.

Doors intended for staff and freight are dealt with in clauses 4.2.2.8 and 4.2.9.1.2 of this TSI.

The control of external passenger access doors is a safety related function; the functional requirements expressed in this clause are necessary to ensure the safety level required; the safety level required for the control system described in points D and E below is an open point.

A — Terminology used:

- In the context of this clause a 'door' is an external passenger access door, intended primarily for passengers to enter and leave the unit.
- A 'locked door' is a door held closed by a physical door locking device
- A 'door locked out of service' is a door immobilised in a closed position by a manually operated mechanical locking device.



**▼B**

- A door ‘released’ is a door that is able to be opened by operating the local or, central door control, (where the latter is available).
- For the purpose of this clause, a train is at a standstill when the speed has decreased to 3km/h or less.

**B — Door closing and locking**

The door control device shall allow the train crew to close and lock all the doors before the train departs.

When the centralised door closing and locking is activated from a local control, adjacent to a door, it is permissible for this door to remain open when the other doors close and lock. The door control system shall allow the staff to close and lock this door subsequently before departure.

The doors shall be kept closed and locked until they are released in accordance with subsection E ‘Door opening’ of this clause. In the event of loss of power to the door controls, the doors shall be kept locked by the locking mechanism.

**C — Locking a door out of service**

A manually operated mechanical device shall be provided to enable (the train crew or maintenance staff) to lock a door out of service.

The locking out of service device shall:

- isolate the door from any opening command,
- lock the door mechanically in the closed position,
- indicate the status of the isolation device,
- permit the door to be by-passed by the ‘door-closed proving system’.

It shall be possible to indicate a door locked out of service by a clear marking according to PRM TSI §4.2.2.8 ‘Customer Information’.

**D — Information available to the train crew**

An appropriate ‘doors-closed proving system’ shall allow the driver to check at any moment whether or not all the doors are closed and locked.

If one or more doors are not locked, this shall be continuously indicated to the driver.

An Indication shall be provided to the driver of any fault of a door closing and/or locking operation.

Audible and visual alarm signal shall indicate to the driver, an emergency opening of one or more doors.

A ‘door locked out of service’ is permitted to be by-passed by the ‘doors-closed proving system’.

**E — Door opening**

A train shall be provided with door release controls, which allow the crew or an automatic device associated with the stop at a platform, to control the release of doors separately on each side, allowing them to be opened by passengers or, if available, by a central opening command when the train is at a standstill.

**▼B**

At each door, local opening controls or opening devices shall be accessible for passengers from both the outside and the inside of the vehicle.

F — Door — Traction interlock

Traction power shall be applied only when all doors are closed and locked. This shall be ensured through an automatic door-traction interlock system. The door-traction interlock system shall prevent traction power being applied when not all of the doors are closed and locked.

The traction interlock system shall be provided with a manual override, intended to be activated by the driver in exceptional situations, to apply traction even when not all of the doors are closed and locked.

G — Door emergency opening

The requirements of clause 4.2.2.4.2.1 g- of the HS RST TSI:2008 shall apply.

Applicability to units intended for general operation:

Only functionalities that are relevant to the design characteristics of the unit (e.g. presence of a cab, of a crew interface system, ...) shall be considered.

The signals transmission required between the unit and the other coupled unit(s) in a train for the door system to be available at train level shall be implemented and documented, taking into account functional aspects.

This TSI does not impose any technical solution regarding physical interfaces between units.

4.2.5.7. Exterior door system construction

If a unit is fitted with a door intended to be used by passengers to access or egress the train, the following provisions apply:

Doors shall be fitted with transparent windows to allow passengers to identify the presence of a platform.

The outside surface of passenger units shall be designed in such a way that they do not give the possibility for a person to ‘train surf’ when the doors are closed and locked.

As a measure to prevent ‘train surfing’, handholds on the outside surface of the door system shall be avoided or designed so that they cannot be gripped when the doors are closed.

Handrails and handholds shall be fixed so that they can withstand the forces exerted on them during operation.

4.2.5.8. Inter-unit doors

This clause is applicable to all units designed to carry passengers.

Where a unit is equipped with inter-unit doors at the end of coaches or at unit-ends, they shall be fitted with a device that allows them to be locked (e.g. where a door is not connected by a gangway for use of passengers to an adjacent coach or unit, etc.).

**▼B**

## 4.2.5.9. Internal air quality

In regular operation the quantity and quality of air provided inside the area of vehicles occupied by passengers and/or staff shall be such that no risk is developed to the health of passengers or staff additional to those resulting from the external ambient air quality.

A ventilation system shall maintain an acceptable interior CO<sub>2</sub> level under operational conditions.

— The CO<sub>2</sub> level shall not exceed 5 000 ppm in all normal operating conditions.

— In case of interruption of the ventilation, due to an interruption of the main power supply or to a breakdown of the system, an emergency provision shall ensure the supply of outside air into all passenger and staff areas.

If this emergency provision is ensured through battery supplied forced ventilation, measurements shall be performed in order to define the duration in which the CO<sub>2</sub> level will remain below 10 000 ppm, assuming a passenger load derived from the load condition 'design mass under normal payload'. The duration shall be recorded in the rolling stock register defined in clause 4.8 of this TSI and shall not be less than 30 minutes.

— Train staff shall have the possibility of preventing passengers being exposed to environmental fumes that may be present, especially in tunnels. This requirement shall be satisfied by compliance to clause 4.2.7.11.1 of the HS RST TSI.

## 4.2.5.10. Body side windows

Where body side windows can be opened by passengers and cannot be locked by the train staff, the size of the opening shall be limited to such dimensions that it is not possible to pass a ball shaped object with 10 cm diameter through it.

4.2.6. *Environmental conditions and aerodynamic effects*

This clause applies to all units.

## 4.2.6.1. Environmental conditions

Environmental conditions are physical, chemical or biological conditions external to a product and to which it is subjected to at a certain time.

The design of rolling stock, as well as its constituents shall take into account the environmental conditions to which this rolling stock will be subjected to.

The environmental parameters are described in the clauses below; for each environmental parameter, a nominal range is defined, which is the most commonly encountered in Europe, and is the basis for interoperable rolling stock.

For certain environmental parameters, ranges other than the nominal one are defined; in that case, a range shall be selected for the design of the rolling stock.

For the functions identified in the clauses below, design and/or testing provisions taken to ensure that the rolling stock is meeting the TSI requirements in this range shall be described in the technical documentation.

**▼B**

The selected range(s) shall be recorded in the register of rolling stock, defined in clause 4.8 of this TSI, as a characteristic of the rolling stock.

Depending on the ranges selected, and on provisions taken (described in the technical documentation), relevant operating rules could be necessary to ensure the technical compatibility between the rolling stock and environmental conditions that can be met on parts of the TEN network.

In particular, operating rules are necessary when rolling stock designed for the nominal range is operated on a particular line of the TEN network where the nominal range is exceeded at certain periods of the year.

The ranges, if different than the nominal one, to be selected to avoid any restrictive operating rule(s) linked to a geographical area and climatic conditions, are specified by the Member States and are listed in the clause 7.4.

**4.2.6.1.1. Altitude**

Rolling stock shall meet the requirements of this TSI for the selected range as defined in EN 50125-1:1999 clause 4.2.

The selected range shall be recorded in the rolling stock register.

**4.2.6.1.2. Temperature**

Rolling shall meet the requirements of this TSI within one (or several) of the climatic zones T1 (– 25 °C to + 40 °C; nominal), or T2 (– 40 °C to + 35 °C) or T3 (– 25 °C to + 45 °C) as defined in EN50125-1:1999 clause 4.3.

The selected temperature zone(s) shall be recorded in the rolling stock register.

The temperature to consider for design purpose of rolling stock constituents shall take into account their integration in the rolling stock.

**4.2.6.1.3. Humidity**

Rolling stock shall meet the requirements of this TSI without degradation for humidity levels as defined in EN 50125-1:1999 clause 4.4.

The effect of humidity to consider for design purpose of rolling stock constituents shall take into account their integration in the rolling stock.

**4.2.6.1.4. Rain**

Rolling stock shall meet the requirements of this TSI considering a rate of rain as defined in EN 50125-1:1999 clause 4.6.

**4.2.6.1.5. Snow, ice and hail**

Rolling stock shall meet the requirements of this TSI without degradation for snow, ice and hail conditions as defined in EN 50125-1:1999 clause 4.7, which correspond to the nominal conditions (range).

The effect of snow, ice and hail to consider for design purpose of rolling stock constituents shall take into account their integration in the rolling stock.

**▼B**

Where more severe ‘snow, ice and hail’ conditions are selected, rolling stock and the parts of the subsystem shall then be designed to meet TSI requirements considering the following scenarios:

- Snowdrift (light snow with low water equivalent content), covering the track up to 80 cm continuously above top rail level.
- Powder snow, snowfall of large quantities of light snow with low water equivalent content.
- Temperature gradient, temperature and humidity variation during one single run causing ice build-ups on the rolling stock.
- Combined effect with low temperature according to the temperature zone chosen as defined in clause 4.2.6.1.2.

In relation with clause 4.2.6.1.2 (climatic zone T2) and with the present clause 4.2.6.1.5 (severe conditions for snow, ice and hail) of this TSI, the provisions taken to meet TSI requirements in these severe conditions shall be identified and verified, in particular design and/or testing provisions that are required for the following TSI requirements:

- Obstacle deflector as defined in this TSI clause 4.2.2.5: additionally, capability to remove snow in front of the train.

Snow shall be considered as an obstacle to be removed by the obstacle deflector; the following requirements are defined in clause 4.2.2.5 (by reference to EN 15227):

‘The obstacle deflector needs to be of sufficient size to sweep obstacles clear of the path of the bogie. It shall be a continuous structure and shall be designed so as not to deflect objects upwards or downwards. Under normal operating conditions, the lower edge of the obstacle deflector shall be as close to the track as the vehicle movements and gauge line will permit.

In plan view the deflector should approximate to a “V” profile with an included angle of not more than 160°. It can be designed with a compatible geometry to function also as a snow plough.’

The forces specified in clause 4.2.2.5 of this TSI are deemed to be sufficient in order to remove the snow.

- Running gear as defined in the TSI clause 4.2.3.5: considering snow and ice build up and possible consequence on running stability and brake function.
- Brake function and brake power supply as defined in the TSI clause 4.2.4.
- Signalling the presence of the train to others as defined in the TSI clause 4.2.7.
- Providing a view ahead as defined in the TSI clause 4.2.7.3.1.1 (head lights) and 4.2.9.1.3.1 (front visibility), with windscreen’s equipment as defined in clause 4.2.9.2 functioning.
- Providing the driver with acceptable climate for working as defined in the TSI clause 4.2.9.1.7.

The provision adopted shall be documented in the technical documentation described in clause 4.2.12.2 of this TSI.

The selected range for ‘snow, ice and hail’ (nominal or severe) shall be recorded in the rolling stock register.

**▼B**

## 4.2.6.1.6. Solar radiation

Rolling stock shall meet the requirements of this TSI for solar radiations as defined in EN 50125-1:1999 clause 4.9.

The effect of solar radiation to consider for design purpose of rolling stock constituents shall take into account their integration in the rolling stock.

## 4.2.6.1.7. Resistance to pollution

Rolling stock shall meet the requirements of this TSI considering its environment and the pollution effect created by its interaction with the following list of substances:

- Chemically active substances Class 5C2 of EN 60721-3-5:1997.
- Contaminating fluids Class 5F2 (electrical engine) of EN 60721-3-5:1997.
- Class 5F3 (thermal engine) of EN 60721-3-5:1997.
- Biologically active substances Class 5B2 of EN 60721-3-5:1997.
- Dust Defined by class 5S2 of EN 60721-3-5:1997.
- Stones and other objects: Ballast and other of maximum 15 mm diameter.
- Grasses and leaves, pollen, flying insects, fibres etc. (design of ventilation ducts)
- Sand according to EN 60721-3-5:1997.
- Sea spray according to EN 60721-3-5:1997 Class 5C2.

*Note:* Reference to standards in this clause is relevant only for the definitions of substances having a polluting effect.

The polluting effect as described above has to be evaluated at the design stage.

## 4.2.6.2. Aerodynamic effects

The passing of a train causes an unsteady airflow with varying pressures and flow velocities. These pressure and flow velocity transients have an effect on persons, objects and buildings at the trackside; they have also an effect on the rolling stock.

The combined effect of train speed and air speed causes an aerodynamic rolling moment that can affect the stability of rolling stock.

## 4.2.6.2.1. Slipstream effects on passengers on platform

Rolling stock running in the open air at a maximum operating speed  $v_{tr} > 160$  km/h, shall not cause the air speed to exceed value  $u_{2\sigma} = 15,5$  m/s at a height of 1,2 m above the platform and at a distance of 3,0 m from the track centre, during the passage of rolling stock.

The train formation to be used for test is specified below for different types of rolling stock:

- Unit assessed in fixed or predefined formation

**▼B**

The full length of the fixed or the maximum length of the pre-defined formation (i.e. the maximum number of units permitted to be coupled together)

- Unit assessed for use in general operation (train formation not defined at design stage): open point

#### 4.2.6.2.2. Slipstream effects on workers at the track side

Rolling stock running in the open air at a maximum operating speed  $v_{tr} > 160$  km/h, shall not cause the air speed to exceed a value  $u_{2\sigma} = 20$  m/s at the trackside as measured at a height of 0,2 m above top of rail and at a distance of 3,0 m from the track centre during the passage of rolling stock.

The train formation to be used for test is specified below for the different types of rolling stock:

- Unit assessed in fixed or predefined formation

The full length of the fixed or the maximum length of the pre-defined formation (i.e. the maximum number of units permitted to be coupled together)

- Unit assessed for use in general operation (train formation not defined at design stage): open point

#### 4.2.6.2.3. Head pressure pulse

The crossing of two trains generates an aerodynamic load on each of the two trains. The requirement below on head pressure pulse in open air allows defining a limit aerodynamic load during the crossing of two trains that has to be considered for the design of rolling stock, assuming a track centre distance of 4,0 m.

Rolling stock running with a speed higher than 160 km/h in the open air shall not cause the maximum peak-to-peak pressure of changes to exceed a value  $\Delta p_{2\sigma}$  of 720 Pa as measured over the range of height between 1,5 m and 3,3 m above the top of rail, and at a distance of 2,5 m from the track centre, during the passage of the head.

The formation to be verified by a test is specified below for different types of rolling stock:

- Unit assessed in fixed or predefined formation

A single unit of the fixed formation or any configuration of the pre-defined formation.

- Unit assessed for use in general operation (train formation not defined at design stage)

- Unit fitted with a drivers cab shall be assessed alone.

- Other units: Requirement not applicable.

**▼ B**

## 4.2.6.2.4. Maximum pressure variations in tunnels

For conventional rail, the CR INF TSI does not specify any target value for the minimum area of tunnels. Therefore, there are no harmonised requirements at rolling stock level regarding this parameter, and no assessment required.

*Note:* Operating conditions of rolling stock in tunnels have to be considered when necessary (outside of the scope of this TSI).

## 4.2.6.2.5. Cross wind

Characteristics of wind to be considered for the design of rolling stock: there is no harmonised value agreed (open point).

Assessment method: standards under development in order to harmonise these methods are not yet available (open point).

*Note:* In order to have the necessary information available to define operating conditions (outside the scope of the TSI), the characteristics of the cross wind (speed) considered in the design of the rolling stock and the assessment method used (as required by the national rule in the concerned Member State, if any) shall be reported in the technical documentation.

Operating conditions may include measures at the level of infrastructure (protection against wind areas) or operation (speed limitation).

## 4.2.7. External lights and visible and audible warning devices

## 4.2.7.1. External lights

The colour green shall not be used for any external light or illumination. This requirement is made to prevent any confusion with fixed signals.

## 4.2.7.1.1. Head lights

This clause applies to units fitted with a driver's cab.

Two white headlamps shall be provided at the front end of the train in order to give visibility for the train driver.

These headlamps shall be arranged on the horizontal axis at the same height above the rail level, symmetrical about the centre line, and at a minimum of 1 000 mm apart. Headlights shall be mounted between 1 500 and 2 000 mm above the rail level.

The colour of headlamps shall be in accordance with the 'White class A' or 'White class B' colour, as defined in the standard CIE S 004.

Headlamps shall provide 2 luminous intensity levels: 'dimmed headlamp' and 'full-beam headlamp'.

For 'dimmed headlamp', the luminous intensity of headlamps measured along the optical axis of the head lamp shall be in accordance with the values specified in the standard EN 15153-1:2007, clause 5.3.5, table 2, first line.

For 'full-beam headlamp', the minimum luminous intensity of headlamps measured along the optical axis of the lamp shall be in accordance with the values specified in the standard EN 15153-1:2007, clause 5.3.5, table 2, first line.



**▼B**

## 4.2.7.1.2. Marker lights

This clause applies to units fitted with a driver's cab.

Three white marker lamps shall be provided at the front end of the train in order to make the train visible.

Two marker lamps shall be arranged on the horizontal axis at the same height above the rail level, symmetrically about the centre line, and at a minimum of 1 000 mm apart; they shall be mounted between 1 500 and 2 000 mm above the rail level.

The third marker lamp shall be arranged centrally above the two lower lamps, with a minimum vertical separation of 600 mm.

It is permitted to use the same component for both head lights and marker lights.

The colour of marker lamps shall be in accordance with the 'White class A' or 'White class B' colour, as defined in the standard CIE S 004.

The luminous intensity of marker lamps shall be in accordance with EN 15153-1:2007, clause 5.4.4.

## 4.2.7.1.3. Tail lights

Two red tail lamps shall be provided at the rear end of units intended to be operated at the rear end of the train in order to make the train visible.

For units assessed for general operation, the lamps may be portable lamps; in that case, the type of portable lamp to be used shall be described in the technical documentation and the function shall be verified by design examination and type test at component level (portable lamp), but it is not required to provide the portable lamps.

The tail lamps shall be arranged on the horizontal axis at the same height above the rail level, symmetrically about the centre line, and at a minimum of 1 000 mm apart; they shall be mounted between 1 500 and 2 000 mm above the rail level.

The colour of tail lamps shall be in accordance with EN 15153-1:2007, clause 5.5.3 (values).

The luminous intensity of tail lamps shall in accordance with EN 15153-1:2007, clause 5.5.4 (value).

## 4.2.7.1.4. Lamp controls

This clause applies to units fitted with a driver's cab.

It shall be possible for the driver to control the head, marker and tail lamps of the unit from the normal driving position; this control may use independent command or combination of commands.

*Note:* It is not required to control the lights in a particular combination to display an emergency warning signal in case of emergency situation.

## 4.2.7.2. Horn (audible warning device)

## 4.2.7.2.1. General

This clause applies to units fitted with a driving cab.

**▼ B**

Trains shall be fitted with warning horns in order to make the train audible.

The notes of the audible warning horns are intended to be recognisable as being from a train and not be similar to warning devices used in road transport or as factory or other common warning device.

The operation of the warning horns shall emit at least one of the following separate warning sounds below:

- Sounding 1: the fundamental frequency of the separately sounded note shall be  $660 \text{ Hz} \pm 30 \text{ Hz}$  (high note).
- Sounding 2: the fundamental frequency of the separately sounded note shall be  $370 \text{ Hz} \pm 20 \text{ Hz}$  (low note).

#### 4.2.7.2.2. Warning horn sound pressure levels

The C weighted sound pressure level produced by each horn sounded separately (or in a group if designed to sound simultaneously as a chord) shall be between 115dB and 123 dB, as defined in EN 15153-2:2007 clause 4.3.2.

#### 4.2.7.2.3. Protection

Warning horns and their control systems shall be designed or protected, so far as is practicable, to maintain their function when impacted by airborne objects such as debris, dust, snow, hail or birds.

#### 4.2.7.2.4. Horn control

It shall be possible for the driver to sound the audible warning device from all driving positions specified in clause 4.2.9 of this TSI.

### 4.2.8. *Traction and electrical equipment*

#### 4.2.8.1. Traction performance

##### 4.2.8.1.1. General

The purpose of the train traction system is to ensure that the train is able to be operated at various speeds up to its maximum service speed. The primary factors that influence traction performance are traction power, train composition and mass, adhesion, track gradient and train running resistance.

Unit performance for units fitted with traction equipment, and operated in various train formations shall be defined so that the overall traction performance of the train can be derived.

The traction performance is characterised by the maximum service speed and by the traction force profile (force at wheel rim =  $F(\text{speed})$ ).

The unit is characterised by its running resistance and its mass.

The maximum service speed, the traction force profile and the running resistance are the unit contributions necessary to define a timetable allowing a train to slot into the overall traffic pattern on a given line, and are part of the technical documentation related to the unit.

**▼B**

## 4.2.8.1.2. Requirements on performance

This clause applies to units fitted with traction equipment.

Unit traction force profiles (force at wheel rim =  $F(\text{speed})$ ) shall be determined by calculation; the unit running resistance shall be determined by a calculation for the load case 'design mass under normal payload', as defined in clause 4.2.2.10.

Unit traction force profiles and running resistance shall be recorded in the technical documentation (see clause 4.2.12.2).

The design maximum speed shall be defined from the data above for the load case 'design mass under normal payload' on a level track.

The design maximum speed shall be recorded in the rolling stock register defined in clause 4.8 of this TSI.

Requirements regarding the traction cut-off required in case of braking are defined in the clause 4.2.4 of this TSI.

Requirements regarding availability of the traction function in case of fire on board are defined in the SRT TSI, clause 4.2.5.3 (freight train) and clause 4.2.5.5 (passenger train).

## 4.2.8.2. Power supply

## 4.2.8.2.1. General

Requirements applicable to rolling stock, and which interface with the energy subsystem are dealt with in this clause. Therefore, this clause 4.2.8.2 applies to electric units.

The CR energy TSI defines the AC 25 kV 50 Hz system as a target system, and allows the use of the AC 15 kV 16,7 Hz system and of the DC 3 kV or 1,5 kV systems. As a consequence, requirements defined below are related to these 4 systems only, and references to standards are valid for these 4 systems only.

The CR energy TSI allows the use of catenary systems compatible with pantograph heads geometry of lengths 1 600 mm or 1 950 mm (see clause 4.2.8.2.9.2).

## 4.2.8.2.2. Operation within range of voltages and frequencies

Electric units shall be able to operate within the range of at least one of the systems 'voltage and frequency' defined in the CR energy TSI, clause 4.2.3.

The actual value of the line voltage shall be available in the driver cab in driving configuration.

The systems 'voltage and frequency' for which the rolling stock is designed shall be recorded in the rolling stock register defined in clause 4.8 of this TSI.

**▼B****4.2.8.2.3. Regenerative brake with energy to the overhead contact line**

Electric units which return electrical energy to the overhead contact line in regenerative braking mode shall comply with the clause 12.1.1 of EN 50388:2005.

It shall be possible to prevent the use of the regenerative brake.

**4.2.8.2.4. Maximum power and current from the overhead contact line**

Electric units with power higher than 2 MW (including the declared fixed and predefined formations) shall be equipped with current limitation function as required in clause 7.3 of EN 50388:2005.

Electric units shall be equipped with automatic regulation of the current within abnormal operation condition regarding voltage as required in clause 7.2 of EN 50388:2005.

The maximum current assessed here above (rated current) shall be recorded in RST register defined in clause 4.8 of this TSI.

**4.2.8.2.5. Maximum current at standstill for DC systems**

For DC systems, the maximum current at standstill per pantograph shall be calculated and verified by measurement.

Limit values are specified in clause 4.2.6 of the CR energy TSI; higher values than those limits shall be recorded in the rolling stock register defined in clause 4.8 of this TSI.

**4.2.8.2.6. Power factor**

The power factor design data shall be as set out in Annex G of the CR energy TSI.

**4.2.8.2.7. System energy disturbances for AC systems**

An electric unit shall not cause unacceptable over-voltage and other phenomena described in EN50388:2005 clause 10.1(harmonics and dynamic effects) on the overhead contact line.

A compatibility assessment shall be done in accordance with the methodology defined in the clause 10.3 of EN 50388:2005. The steps and hypothesis described in table 6 of EN50388:2005 have to be defined by the applicant (column 3 not applicable), taking into consideration input data given in Annex D of the same standard; the acceptance criteria shall be as defined in clause 10.4 of EN 50388:2005.

All hypotheses and data considered for this compatibility study shall be recorded in the technical documentation (see clause 4.2.12.2).

**4.2.8.2.8. Energy consumption measuring function**

This clause applies to electric units.

**▼ B**

If an electric energy consumption measuring equipment is installed, it shall be compatible with requirements of the Annex D of this TSI. This equipment can be used for billing purposes and the data provided by it shall be accepted for billing in all Member States.

The fitment of an energy measuring system shall be recorded in the rolling stock register defined in clause 4.8 of this TSI.

*Note:* Where the location function is not necessary for billing purposes in the Member State concerned, it is permissible to not install the components dedicated to that function. In any case, any such system shall be designed with consideration of the possible future use of the location function.

#### 4.2.8.2.9. Requirements linked to pantograph

##### 4.2.8.2.9.1. WORKING RANGE IN HEIGHT OF PANTOGRAPH

###### 4.2.8.2.9.1.1. *HEIGHT OF INTERACTION WITH CONTACT WIRES (RST LEVEL)*

The installation of a pantograph on an electric unit shall allow mechanical contact from at least one of the contact wires at heights between:

— 4 800 mm and 6 500 mm above rail level for tracks designed in accordance with the gauge GC,

— 4 500 mm and 6 500 mm above rail level for tracks designed in accordance with the gauge GA/GB.

###### 4.2.8.2.9.1.2. *WORKING RANGE IN HEIGHT OF PANTOGRAPH (IC LEVEL)*

Pantographs shall have a working range of at least 2 000 mm. The characteristics to be verified shall be in accordance with the requirements of clauses 4.2 and 6.2.3 of EN 50206-1:2010.

##### 4.2.8.2.9.2. PANTOGRAPH HEAD GEOMETRY (IC LEVEL)

At least one of the pantograph(s) to be installed on an electric unit shall have a head geometry type compliant with one of the two specifications given in the clauses below.

The type(s) of pantograph head geometry that an electric unit is equipped with shall be recorded in the rolling stock register defined in clause 4.8 of this TSI.

Pantograph heads fitted with contact strips having independent suspensions shall remain compliant to the overall profile with a static contact force of 70N applied to the middle of the head. The permissible value for pantograph head skew is defined in EN 50367:2006 clause 5.2.

Contact between contact wire and pantograph head is permitted outside the contact strips and within the whole conducting range over limited line sections under adverse conditions, e.g. coincidence of vehicle swaying and high winds.

**▼B**4.2.8.2.9.2.1. *PANTOGRAPH HEAD GEOMETRY TYPE 1 600 MM*

The profile of the pantograph head shall be as depicted in EN 50367:2006, Annex A.2, figure A.7.

4.2.8.2.9.2.2. *PANTOGRAPH HEAD GEOMETRY TYPE 1 950 MM*

The profile of the pantograph head shall be as depicted in EN 50367:2006, Annex B.2, figure B.3, with height 340 mm instead of the stated 368 mm, and a conducting range of collector head of at least 1 550 mm.

Insulated or non-insulated material for the horns are both permitted.

4.2.8.2.9.3. *PANTOGRAPH CURRENT CAPACITY (IC LEVEL)*

Pantographs shall be designed for the rated current (as defined in clause 4.2.8.2.4) to be transmitted to the electric unit.

An analysis shall demonstrate that the pantograph is able to carry the rated current; this analysis shall include the verification of the requirements of clause 6.13.2 of EN50206-1:2010.

Pantographs for DC systems shall be designed for the maximum current at standstill (as defined in clause 4.2.8.2.5 of this TSI).

4.2.8.2.9.4. *CONTACT STRIP (IC LEVEL)*4.2.8.2.9.4.1. *CONTACT STRIP GEOMETRY*

Contact strips shall be geometrically designed to be fitted to one of the pantograph head geometries specified in clause 4.2.8.2.9.2.

4.2.8.2.9.4.2. *CONTACT STRIP MATERIAL*

Material used for the contact strips shall be mechanically and electrically compatible with the contact wire material (as specified in clause 4.2.18 of the CR energy TSI), in order to avoid excessive abrasion of the surface of the contact wires, thereby minimising wear of both contact wires and contact strips.

For contact strips used on AC lines only, plain carbon shall be permitted. For AC systems, the use of other material than those specified above is an open point.

For contact strips used on DC lines only, plain carbon, impregnated carbon with additive material or impregnated carbon with clad copper shall be permitted; where a metallic additive material is used, the metallic content of the carbon contact strips shall not exceed a content of 40 % by weight. For DC systems, the use of other material than those specified above is an open point.

For contact strips used on both AC and DC lines, plain carbon shall be permitted. For use on both AC and DC systems, the use of other material than those specified above is an open point.

**▼B**

*Note:* This open point is not safety related, and it is therefore acceptable that the operating documentation (as specified in clause 4.2.12.4) allow the use of carbon with additive material on AC lines in degraded conditions (i.e. in case of failure of the control circuit of one of the pantographs, or other failure affecting the onboard power supply) in order to continue a journey.

4.2.8.2.9.4.3. *CONTACT STRIP CHARACTERISTICS*

Contact strips are the replaceable parts of the pantograph head, which are in direct contact with the contact wire and as a consequence, are prone to wear.

## 4.2.8.2.9.5. PANTOGRAPH STATIC CONTACT FORCE (IC LEVEL)

The static contact force is the vertical contact force exerted upward by the pantograph head on the contact wire and caused by the pantograph-raising device, when the pantograph is raised and the vehicle is at standstill.

The static contact force exerted by the pantograph on the contact wire, as defined above, shall be adjustable within the following ranges:

- 60 N to 90 N for AC supply systems,
- 90 N to 120 N for DC 3 kV supply systems,
- 70 N to 140 N for DC 1,5 kV supply systems.

## 4.2.8.2.9.6. PANTOGRAPH CONTACT FORCE AND DYNAMIC BEHAVIOUR

The mean contact force  $F_m$  is the statistical mean value of the pantograph contact force, and is formed by the static and aerodynamic components of the contact force with dynamic correction.

The factors which influence the mean contact force are the pantograph itself, its position in the train consist, its vertical extension, and the rolling stock on which the pantograph is mounted.

Rolling stock and pantographs fitted on rolling stock are designed to exert a mean contact force  $F_m$  on the contact wire in a range specified in clause 4.2.16 of the CR energy TSI, in order to ensure current collection quality without undue arcing and to limit wear and hazards to contact strips. Adjustment of the contact force is made when dynamic tests are performed.

The verification at interoperability constituent level shall validate the dynamic behaviour of the pantograph itself, and its capability to collect current from a TSI compliant overhead contact line (see clause 6.1.2.2.6).

The verification at rolling stock subsystem level shall allow to adjust the contact force, taking into account aerodynamic effects due to the rolling stock and the position of the pantograph in the unit or train fixed or predefined formation(s) (see clause 6.2.2.2.15).

**▼ B**

## 4.2.8.2.9.7. ARRANGEMENT OF PANTOGRAPHS (RST LEVEL)

It is permissible for more than one pantograph to be simultaneously in contact with the overhead contact line equipment.

The number of pantographs and their spacing shall be designed taking into consideration the requirements of current collection performance, as defined in clause 4.2.8.2.9.6 above.

Where the spacing of 2 consecutive pantographs in fixed or pre-defined formations of the assessed unit is less than the spacing shown in clause 4.2.17 of the CR energy TSI for the selected OCL design distance type, or where more than 2 pantographs are simultaneously in contact with the overhead contact line equipment, it shall be demonstrated by testing that the current collection quality as defined in clause 4.2.8.2.9.6 above is met for the poorest performing pantograph.

The OCL design distance type (A, B or C as defined in the clause 4.2.17 of the CR energy TSI) selected (and therefore used for the test) shall be recorded in the technical documentation (see clause 4.2.12.2).

## 4.2.8.2.9.8. RUNNING THROUGH PHASE OR SYSTEM SEPARATION SECTIONS (RST LEVEL)

Trains shall be designed to be able to move from one power supply system and from one phase section to an adjacent one without bridging either system or phase separation sections.

When running through phase separation sections, it shall be possible to bring the power consumption of the unit to zero as required in the clause 4.2.19 of the CR energy TSI. The infrastructure register gives information on the permitted pantographs position: lowered or raised (with permitted pantograph arrangements) when running through systems or phase separation sections.

Rolling stock designed for several power supply systems shall, when running through system separation sections, recognise automatically the voltage of the power supply system at the pantograph.

## 4.2.8.2.9.9. INSULATION OF PANTOGRAPH FROM THE VEHICLE (RST LEVEL)

The pantographs shall be assembled on an electric unit in a way that ensures they are insulated from earth. The insulation shall be adequate for all system voltages.

## 4.2.8.2.9.10. PANTOGRAPH LOWERING (RST LEVEL)

Electric units shall be designed to lower the pantograph in a period meeting the requirements of EN50206-1:2010, clause 4.7 (3 seconds) and to the dynamic insulating distance according to EN 50119:2009 table 2 either by initiation by the driver or by a train control function (including CCS functions). The pantograph shall lower to the stowed position in less than 10 seconds.



**▼B**

When lowering the pantograph, the main circuit breaker shall previously be opened automatically.

If an electric unit is equipped with an automatic dropping device (ADD) that lowers the pantograph in case of a collector head failure, the ADD shall meet the requirements of clause 4.8 of EN50206-1:2010.

It shall be allowed to equip electric units with an ADD.

Mandatory requirement for electric units designed for a maximum speed higher or equal to 100 km/h to be equipped with an ADD is an open point.

#### 4.2.8.2.10. Electrical protection of the train

Electric units shall be protected against internal short –circuits (from inside the unit).

The location of the main circuit breaker shall be such as to protect the onboard high voltage circuits, including any high voltage connections between vehicles. The pantograph, the main circuit breaker, and the high voltage connection between them shall be located on the same vehicle.

In order to prevent electric hazards, any unintentional energisation shall be avoided; the control of the main circuit breaker is a safety related function; the safety level required is an open point.

Electric units shall protect themselves against short over-voltages, temporary over-voltages and maximum fault current. To meet this requirement, electrical protection coordination design shall comply with the requirements defined in the standard EN 50388:2005, clause 11 ‘coordination of protection’; table 8 of this clause shall be replaced by Annex H of the CR energy TSI.

#### 4.2.8.3. Diesel and other thermal traction system

Diesel engines are to comply with the EU legislation concerning exhaust (composition, limit values).

#### 4.2.8.4. Protection against electrical hazards

Rolling stock and its electrically live components shall be designed such that intentional and unintentional contact (direct or indirect contact) with train staff and passenger is prevented, both in normal cases and in cases of equipment failure. Provisions described in the standard EN 50153:2002 shall be applied in order to meet this requirement.

#### 4.2.9. *Driver’s cab and driver-machine interface*

The requirements specified in this clause 4.2.9 apply to units fitted with a driver’s cab.

##### 4.2.9.1. Driver’s cab

###### 4.2.9.1.1. General

The driver’s cabs shall be designed to permit operation by a single driver.

The maximum noise level allowed in the cab is specified in the noise TSI.

**▼B**

## 4.2.9.1.2. Access and egress

## 4.2.9.1.2.1. ACCESS AND EGRESS IN OPERATING CONDITIONS

The driver's cab shall be accessible from both sides of the train from 200 mm below top of rail.

It is permissible for this access to be either directly from the exterior, using a cab external door, or through a compartment (or area) at the rear of the cab. In the latter case, requirements defined in this clause shall apply to external accesses located in that compartment (or area) on either side of the vehicle.

The means for the train crew to access in and to egress out of the cab, such as footsteps, handrails or opening handles, shall allow safe and easy usage by being of adequate dimensions (pitch, width, spacing, shape); they shall be designed with consideration of ergonomic criteria in relation with their use. Footsteps shall have no sharp edges causing obstacles for the shoes of the train crew.

Rolling stock with external walkways shall be equipped with handrails and foot bars (kicking strips) for driver safety when accessing the cab.

Driver's cab external doors shall open in such a way that they remain within the gauge (as defined in this TSI) when opened.

Driver's cab external doors shall have a minimum clearance of 1 675 × 500 mm when accessible by foot-steps, or of 1 750 × 500 mm when accessible on floor level.

Interior doors used by the train crew to access the cab shall have a minimum clearance of 1 700 × 430 mm.

The driver's cab and its access shall be designed so that the train crew is able to prevent the cab being accessed by non-authorised persons, whether the cab is occupied or not, and so that a cab occupant is able to go outside of a cab without having to use any tool or key.

Access to the driver's cab shall be possible without any energy supply available on board. Cab external doors shall not open unintentionally.

## 4.2.9.1.2.2. DRIVER'S CAB EMERGENCY EXIT

In an emergency situation, evacuation of the train crew from the driver's cab and access to the interior of the cab by the rescue services shall be possible on both sides of the cab by using one of the following emergency exit means: external doors (see clause 4.2.9.1.2.1 above) or side windows or emergency hatches.

In all cases, the emergency exit means shall provide a minimum clearance (free area) of 2 000 cm<sup>2</sup> with a minimum inner dimension of 400 mm to allow the release of trapped persons.

Front position driver's cabs shall have at least an interior exit; this exit shall give access to an area of a minimum length of 2 metres, of a minimum clearance of height 1 700 mm x width 430 mm, and its floor shall be free of any obstruction; the above area shall be located onboard the unit, and can be an interior area or an area opened to the outside.

**▼B**

## 4.2.9.1.3. External visibility

## 4.2.9.1.3.1. FRONT VISIBILITY

The driver's cab shall be designed to allow the driver at his seated driving position a clear and unobstructed line of sight in order to distinguish fixed signals set to both the left and right of a straight track, and in curves with a radius of 300 m or more, under the conditions defined in Annex F.

The above requirement shall also be met from the standing driving position under conditions defined in the Annex F, on locomotives and driving coaches intended to be used in a train composition with a locomotive.

For locomotives with central cab and for OTMs, in order to ensure the visibility of low signals, it is permitted that the driver moves to several different positions in the cab in order to meet the above requirement; it is not required to meet the requirement from the seated driving position.

## 4.2.9.1.3.2. REAR AND SIDE VIEW

The cab shall be designed to allow the driver to have a rear view of each side of the train at stand still, while at the same time still being able to operate the emergency brake. The above requirement is permitted to be met by one of the following means: opening side windows or panel at each side of the cab, exterior mirrors, camera system.

In case of opening side windows or panel, the opening shall be sufficiently large for the driver to put his head through the aperture.

## 4.2.9.1.4. Interior layout

The interior layout of the cab shall take into account the anthropometric measurements of the driver as set out in the Annex E.

Freedom of movement of personnel in the cab interior shall not be inhibited by obstructions.

The cab floor corresponding to the working area of the driver (access to the cab excluded) shall be without any step.

The interior layout shall allow both seated and standing driving positions on locomotives and driving coaches intended to be used in a train formation with a locomotive.

The cab shall be equipped with at least one driver's seat (see clause 4.2.9.1.5) and additionally with a forward facing seat not considered as a driving position for possible accompanying crew.

## 4.2.9.1.5. Driver's seat

The driver's seat shall be designed in such a way that it allows him to undertake all normal driving functions in a seated position, taking into account the anthropometric measurements of the driver as set out in the Annex E. It shall allow for correct posture of the driver from the physiological point of view.

It shall be possible for the driver to adjust the seat position in order to meet the reference position of eyes for external visibility, as defined in clause 4.2.9.1.3.1.

**▼B**

The seat shall not constitute an obstacle for the driver to escape in case of emergency.

Ergonomics and health aspects shall be considered in the design of the seat, its mounting and its use by the driver.

The mounting of the driver's seat in locomotives and driving coaches intended to be used in a train formation with a locomotive shall allow adjustment to get the necessary free space needed for the standing driving position.

#### 4.2.9.1.6. Driver's desk — Ergonomics

The driver's desk and its operating equipment and controls shall be arranged to enable, in the most commonly used driving position, the driver to keep a normal posture, without hampering his freedom of movement, taking into account the anthropometric measurements of the driver as set out in the Annex E.

To allow the display on the driver's desk surface of paper documents required during driving, a reading zone of minimum size 30 cm width per 21 cm high shall be available in front of the driver's seat.

Operating and control elements shall be clearly marked, so that they are identifiable by the driver.

If the traction and/or braking effort is set-up by a lever (combined one or separated ones), the 'tractive effort' shall increase by pushing the lever forwards, and the 'braking effort' shall increase by drawing the lever towards the driver.

If there is a notch for emergency braking, it shall be clearly distinguished from those of the other positions of the lever.

#### 4.2.9.1.7. Climate control and air quality

The air in the cab shall be renewed to keep the CO<sub>2</sub> concentration to the levels specified in the clause 4.2.5.9 of this TSI.

At the seated driving position (as defined in the clause 4.2.9.1.3) of the driver's head and shoulders, there shall be no air flows caused by the ventilation system having an air velocity exceeding the limit value recognised to ensure a proper working environment.

#### 4.2.9.1.8. Internal lighting

Cab general lighting shall be provided on driver's command in all normal operational modes of the rolling stock (included 'switched off'). Its luminosity shall be higher than 75 lux at the level of the driver's desk.

Independent lighting of the driver's desk reading zone shall be provided on driver's command, and shall be adjustable up to a value higher than 150 lux.

If provided, lighting of instruments shall be independent of the general lighting and shall be adjustable.

In order to prevent any dangerous confusion with outside operational signalling, no green lights or green illumination are permitted in a driver's cab, except for existing class B cab signalling systems (as defined in the CR CCS TSI).

**▼B**

## 4.2.9.2. Windscreen

## 4.2.9.2.1. Mechanical characteristics

The dimension, location, shape and finishes (including maintenance) of the windows shall not inhibit the drivers external view (as defined in clause 4.2.9.1.3.1) and shall support the driving task.

The driver's cab windscreens shall be able to resist impacts from projectiles as specified in the standard EN 15152:2007 clause 4.2.7 and shall resist spalling as specified in EN 15152:2007 clause 4.2.9.

## 4.2.9.2.2. Optical characteristics

The driver's cab windscreens shall be of an optical quality that does not alter the visibility of signs (shape and colour) in any operating condition (including as example when the windscreen is heated to prevent misting and frost).

The angle between primary and secondary images in the installed position shall be as specified in EN 15152:2007 clause 4.2.2.

Permissible optical distortions of vision shall be as specified in EN 15152:2007 clause 4.2.3.

Haze shall be as specified in EN 15152:2007 clause 4.2.4.

Luminous transmittance shall be as specified in EN 15152:2007 clause 4.2.5.

Chromaticity shall be as specified in EN 15152:2007 clause 4.2.6.

## 4.2.9.2.3. Equipment

The windscreen shall be equipped with de-icing, de-misting and external cleaning means, under control of the driver.

The location, type and quality of windscreen cleaning and clearance devices shall ensure that the driver is able to maintain a clear external view in most weather and operating conditions, and shall not inhibit the drivers external view.

Protection shall be provided from the sun without reducing the drivers' view of external signs, signals and other visual information when this protection is in its stowed position.

## 4.2.9.3. Driver machine interface

## 4.2.9.3.1. Driver's activity control function

The driver's cab shall be equipped with a means to monitor the driver's activity, and to automatically stop the train when a lack of driver's activity is detected.

Specification of the means to monitor (and detect a lack of) the driver's activity:

The driver's activity shall be monitored when the train is in driving configuration and is moving (criterion for movement detection is at a low speed threshold); this monitoring shall be done by controlling the action of the driver on dedicated devices (pedal, push buttons, sensitive touches ...) and/or his action on the train control and monitoring system.

**▼B**

When no action is monitored during more than a time of X seconds, a lack of driver's activity shall be triggered.

The system shall allow for the adjustment (at workshop, as a maintenance activity) of the time X within the range of 5 seconds to 60 seconds.

When the same action is monitored continuously for more than a time not higher than 60 seconds, a lack of driver's activity shall also be triggered.

Before triggering a lack of driver's activity, a warning shall be given to the driver, in order for him to have the possibility to react and reset the system.

The detection of the lack of the driver's activity is a safety related function; the safety level required is an open point.

The system shall have the information 'lack of driver's activity triggered' available for being interfaced to other systems (i.e. the radio system).

Specification of actions triggered at train level when a lack of driver's activity is detected:

A lack of driver's activity when the train is in driving configuration and is moving (criterion for movement detection is at a low speed threshold) shall lead to a full service brake or an emergency brake application on the train.

In case of application of a full service brake, its effective application shall be automatically controlled and in case of non-application, it shall be followed by an emergency brake.

*Note:* It is allowed to have the function described in this clause fulfilled by the CCS subsystem.

It is also allowed to install a system of a fixed time X (no adjustment possible) provided that the time X is within the range of 5 seconds to 60 seconds. A Member State may ask for a maximum fixed time for safety reasons, but in any case it cannot prevent the access to a railway undertaking that using a higher time Z (within the range specified), unless that Member State is able to demonstrate that the national safety level is endangered.

#### 4.2.9.3.2. Speed indication

This function and the corresponding conformity assessment are specified in the CR CCS TSI.

#### 4.2.9.3.3. Driver display unit and screens

Functional requirements concerning the information and commands provided in the driver's cab are specified together with other requirements applicable to the specific function, in the clause describing that function. The same applies also to information and commands that may be provided by means of display units and screens.

ERTMS information and commands, including those provided on a display unit, are specified in the CR CCS TSI.

**▼ B**

For functions in the scope of this TSI, the information or commands to be used by the driver to control and command the train, and given by means of display units or screens, shall be designed to allow proper use and reaction from the driver.

**4.2.9.3.4. Controls and indicators**

Functional requirements are specified with other requirements applicable to a specific function, in the clause describing that function.

All indicator lights shall be designed so that they can be read correctly under natural or artificial lighting conditions, including incidental lighting.

Possible reflections of illuminated indicators and buttons in the windows of the driver's cab shall not interfere with the line of sight of the driver in his normal working position.

In order to prevent any dangerous confusion with outside operational signalling, no green lights or green illumination are permitted in a driver's cab, except for existing class B cab signalling system (according CR CCS TSI).

Audible information generated by onboard equipment inside the cab for the driver shall not be lower than 6 dB(A) above the median received noise level in the cab, measured as defined in the noise TSI.

**4.2.9.3.5. Labelling**

The following information shall be indicated in the driving cabs:

- Maximum speed ( $V_{max}$ ).
- Identification number of rolling stock (traction vehicle number).
- Location of portable equipment (e.g. self-rescue device, signals).
- Emergency exit.

Harmonised pictograms shall be used to mark controls and indicators in the cab.

**4.2.9.3.6. Remote control function from the ground**

If a radio remote control function is provided to control the unit from the ground during shunting operations for freight, it shall be designed to allow the driver to control the train movement safely, and to avoid any mistake when used.

This function is identified as safety related.

The design of the remote control function, including safety aspects, shall be assessed according to recognised standards.

**4.2.9.4. Onboard tools and portable equipment**

A space shall be available in or near the driver's cab to store the following equipment, in case they are needed by the driver in emergency situation:

- Hand-lamp with red and white light.

**▼B**

- Short circuiting equipment for track-circuits.
- Scotches, if the parking brake performance is not sufficient depending on track gradient (see clause 4.2.4.5.5 'Parking brake').
- A fire extinguisher in accordance with HS RST TSI:2008 clause 4.2.7.2.3.2.
- On manned traction units of freight trains: a respirator, as specified in the SRT TSI (see SRT TSI clause 4.7.1).

## 4.2.9.5. Storage facility for staff personal effects

Each driver's cab shall be equipped with:

- Two hooks for clothing or a niche with a clothes' beam.
- A free space for storing a suitcase or bag of size 300 mm x 400 mm x 400 mm.

## 4.2.9.6. Recording device

The list of information to be recorded is to be defined in the CR OPE TSI taking into account of the list of information defined in the CR CCS TSI, and on-going studies regarding the need of Investigation Bodies in charge of reporting on accidents.

The means to record this information is in the scope of the present TSI; pending the definition of the list of information to be recorded is completed, the specification of the recording device is an open point.

4.2.10. *Fire safety and evacuation*

## 4.2.10.1. General and categorisation

This clause applies to all units.

Rolling stock intended for use on the CR TEN shall be designed such that it protects passengers and onboard staff in case of hazard e.g. fire on board and to allow an effective evacuation and rescue in case of emergencies. This is deemed to be fulfilled by complying with the requirements of this TSI.

The compatibility between the categories of rolling stock and operations in tunnels is set out in the SRT TSI.

The design fire category shall be recorded in the rolling stock register, as defined in clause 4.8 of this TSI.

## 4.2.10.1.1. Requirements applicable to all units, except freight locomotives and OTMs

Category A:

Rolling stock shall comply as a minimum with:

- the requirements applicable to category A rolling stock as depicted in SRT TSI, and
- the requirements in the clauses 4.2.10.2 to 4.2.10.4 of this TSI.

Category A rolling stock is the minimum category for rolling stock operated on the TEN infrastructures.



**▼ B**

The compatibility between category A rolling stock and sections of tracks where detraining is dangerous other than tunnels (e.g. elevated sections, embankments, trenches, etc.) up to 5 km length is covered by this TSI.

Category B:

Category B rolling stock shall comply with:

- all requirements applicable to category A rolling stock, and
- the requirements applicable to category B rolling stock as depicted in SRT TSI, and
- the requirements in the clause 4.2.10.5 of this TSI.

Category B rolling stock is designed to be operated on all parts of the TEN infrastructures (including long tunnels and long elevated sections).

#### 4.2.10.1.2. Requirements applicable to freight locomotives and OTMs

Freight locomotives shall meet the requirements as set out in:

- SRT TSI clauses applicable to freight locomotives (including those clauses applicable to rolling stock in general), and
- the requirements in clauses 4.2.10.2 Material requirements and 4.2.10.3 Specific measures for flammable liquids, of this TSI.

OTMs shall meet the requirements as set out in:

- SRT TSI clauses: 4.2.5.1 Material properties for rolling stock, 4.2.5.6 Onboard fire detectors, and 4.2.5.7 Communication means on trains,
- the requirements in clauses 4.2.10.2 Material requirements, and 4.2.10.3 Specific measures for flammable liquids, of this TSI.

#### 4.2.10.1.3. Requirements specified in the SRT TSI

The following list gives an overview of the basic parameters covered by the SRT TSI, which are applicable to rolling stock in the scope of the present TSI (*note*: not all parameters are applicable to each type of unit in the scope of this TSI):

- 4.2.5.1. Material properties for rolling stock (1)
- 4.2.5.2. Fire extinguishers for passenger rolling stock
- 4.2.5.3. Fire protection for freight trains
- 4.2.5.4. Fire barriers for passenger rolling stock (1)
- 4.2.5.5. Additional measures for running capability of passenger rolling stock with a fire on board
- 4.2.5.6. Onboard fire detectors
- 4.2.5.7. Communication means on trains (2)
- 4.2.5.8. Emergency brake override (2)
- 4.2.5.9. Emergency lighting system in the train
- 4.2.5.10. Switching off of air conditioning in the train

**▼B**

4.2.5.11. Escape design of passenger rolling stock (1)

4.2.5.12. Rescue service's information and access

The clauses marked with (1) are affected by the contents of clause 4.2.10 of the present TSI.

Since the present TSI differs from the SRT TSI on certain requirements, the TSIs shall be applied as follows:

- SRT TSI clause 4.2.5.1 (Material properties for rolling stock) shall be supplemented by clause 4.2.10.2 (Material requirements) of the present TSI for conventional rolling stock.
- SRT TSI clause 4.2.5.4 (Fire barriers for passenger rolling stock) shall be supplemented by clause 4.2.10.5 (Fire barriers) of the present TSI for conventional rolling stock.
- SRT TSI clause 4.2.5.11.1 (Passengers' emergency exits) shall be substituted by clause 4.2.10.4 (Passenger evacuation) of the present TSI for conventional rolling stock.

The clauses marked with (2) are affected by the contents of clause 4.2.5 of the present TSI (see this clause 4.2.5 for details).

#### 4.2.10.2. Material requirements

This clause supplements SRT TSI clause 4.2.5.1 'Material properties for rolling stock' for conventional rolling stock.

In addition to the provisions in SRT TSI (referring back to the HS RST TSI) and pending the publication of EN45545-2, the requirements relating to the fire behaviour properties of materials and the selection of components is also permitted to be satisfied by the verification of conformity in accordance with TS 45545-2:2009, using the appropriate operation category as specified in TS 45545-1:2009.

#### 4.2.10.3. Specific measures for flammable liquids

Railway vehicles shall be provided with measures preventing a fire from occurring and spreading due to leakage of flammable liquids or gases.

#### 4.2.10.4. Passenger evacuation

This clause substitutes SRT TSI clause 4.2.5.11.1 'Passengers' emergency exits' for conventional rolling stock.

#### Definitions and clarifications

Emergency exit: train borne provision to allow people inside the train to get out of the train in case of an emergency. An external passenger door is a specific type of emergency exit.

Through route: Area in the train which can be entered and left from different sides and which does not obstruct the movement of passengers and staff, along the longitudinal axis of the train. Interior doors on the through route which cannot be locked are considered not to obstruct the movement of passengers and staff.

Passenger area: Area to which passengers have access without particular authorisation.

**▼ B**

Compartment: Passenger area or staff area, which cannot be used as a through route for passengers or staff respectively.

**Requirements**

Emergency exits shall be provided and indicated.

An emergency exit shall be able to be opened by a passenger from inside the train.

Once opened, each emergency exit shall have an opening which is sufficient in size to allow the release of persons. This requirement is deemed to be met when the opened emergency exit includes a rectangular open and free area of at least 700 mm x 550 mm.

Seats or other passenger amenities (table, bed etc.) may be located on the route towards an emergency exit as long as they do not prevent the use of the emergency exit and do not obstruct the free area as defined under the previous point here-above.

All external passenger doors shall be equipped with emergency opening devices allowing them to be used as emergency exits.

From each place inside a through route, an external door shall be reachable within 16m, measured along the longitudinal axis of the vehicle; sleeper and restaurant cars are exempt from this requirement.

For restaurant cars, an emergency exit shall be located within 16 m from each place inside the restaurant car, measured along the longitudinal axis of the vehicle.

For sleeper cars, each sleeping compartment shall have an emergency exit.

Except for toilets and luggage areas, no place inside a passenger compartment shall be located at a distance of more than 6m from an emergency exit, measured along the longitudinal axis of the vehicle. For emergency exits in passenger compartments, additional means to aid a safe and swift evacuation shall be provided if the distance between the lowest point of the emergency exit and the top of rail exceeds 1,8 m.

Each vehicle designed to contain up to 40 passengers shall have at least two emergency exits.

Each vehicle designed to contain more than 40 passengers shall have at least three emergency exits.

Each vehicle intended to carry passengers shall have at least one emergency exit on each vehicle side.

**4.2.10.5. Fire barriers**

This clause supplements SRT TSI clause 4.2.5.4 'Fire barriers for passenger rolling stock' for conventional rolling stock.

In addition to the provisions in the SRT TSI, for category B fire safety rolling stock, the requirement for full 'cross section partitions within passenger/staff areas' is permitted to be met by fire spreading prevention measures (FSPM):

**▼B**

If FSPM are used instead of full cross section partitions, it shall be demonstrated that:

- they ensure that fire and smoke will not extend in dangerous concentrations over a length of more than 28 m within the passenger/staff areas inside a unit, for at least 15 minutes after the start of a fire,
- they are installed in each vehicle of the unit, which is intended to carry passengers and/or staff,
- they provide at least the same level of safety to persons on board as full cross section partitions, with an integrity of 15 minutes, which are tested in accordance with the requirements of EN 1363-1:1999 partition test and assuming the fire can start from either side of the partition.

If the FSPM relies on reliability and availability of systems, components, or functions, their safety level shall be taken into account in the demonstration; in that case the global safety level to be met is an open point.

#### 4.2.11. *Servicing*

##### 4.2.11.1. *General*

Servicing and minor repairs necessary to ensure safe operations between maintenance interventions shall be able to be carried out while the train is stabled away from its normal servicing home base.

This part gathers requirements for provisions relating to the servicing of trains during operation or when stabled on a network. Most of these requirements aim at ensuring that rolling stock will have the equipment necessary to meet the provisions required in the other sections of this TSI and of the Infrastructure TSI.

##### 4.2.11.2. *Train exterior cleaning*

###### 4.2.11.2.1. *Cleaning of driver's cab windscreen*

Applicable to: All units equipped with a driver's cab

It shall be possible for the front windows of drivers' cabs to be cleaned from outside the train without need to remove any component or covering.

###### 4.2.11.2.2. *Exterior cleaning through a washing plant*

It shall be possible to control the speed of trains that are intended to be cleaned externally through a washing plant on level track at a value between 2 km/h and 5 km/h.

This requirement is aimed at ensuring compatibility with washing plants.

##### 4.2.11.3. *Toilet discharge system*

Applicable to: units equipped with sealed retention systems.

Interface with discharge system: The provisions of clause 4.2.9.3 of the HS RST TSI shall be applied.

**▼B**

## 4.2.11.4. Water refilling equipment

Applicable to: All units equipped with water taps.

The water supplied to the train, up to the filling-interface with the rolling stock, on the interoperable network is deemed to be drinking water in accordance with Directive 98/83/EC, as specified in the clause 4.2.13.3 of the CR INF TSI.

The onboard storage equipment shall not induce any additional risk for the health of people to the risks associated with the storage of water filled in accordance with the above provisions.

This requirement is deemed to be met by assessment of piping and sealing material and quality. The materials shall be suitable for transport and storage of water fit for human consumption.

## 4.2.11.5. Interface for water refilling

Applicable to: All units equipped with a refilling interface.

The provisions of HS RST TSI clause 4.2.9.5.2 apply to 'inlet connection for water tanks'.

## 4.2.11.6. Special requirements for stabling of trains

Applicable to all units.

Different functional levels: Provisions of HS RST TSI Clause 4.2.9.7 apply to CR RST vehicles

If a unit is equipped with a power supply to be used while stabled, it shall be compatible with at least one of the following power systems:

- Power supply contact line (see clause 4.2.8.2.9 'Requirements linked to pantograph').
- 'UIC 552-type' train power supply line (AC 1 kV, AC/DC 1.5 kV, DC 3 kV).
- Local external auxiliary power supply: this is an open point.

## 4.2.11.7. Refuelling equipment

Applicable to units equipped with a refuelling system.

Where rolling stock is equipped with a refuelling system, e.g. trains using diesel fuel, this equipment shall comply with the requirements of UIC 627-2:Jul 1980 §1.

*Note:* This will be subject of an EN standard currently under drafting process.

Open point: Nozzles for alternative fuels (bio fuel, CNG etc.).

## 4.2.12. Documentation for operation and maintenance

The requirements specified in this clause 4.2.12 apply to all units.

**▼B**

## 4.2.12.1. General

This clause 4.2.12 of the TSI describes the documentation requested in clause 4 sub-paragraph 2 of Annex VI of Directive 2008/57/EC (clause titled ‘Technical file’):

‘— for the other subsystems: general and detailed drawings in line with execution, electrical and hydraulic diagrams, control-circuit diagrams, description of data-processing and automatic systems, operating and maintenance manuals, etc.’;

This documentation, being part of the technical file, is compiled by the notified body and has to accompany the EC declaration of verification.

This documentation, being part of the technical file, is lodged with the applicant, and is kept by the applicant throughout the service life of the subsystem.

The documentation requested is related to the basic parameters identified in this TSI. Its content is described in the clauses below.

## 4.2.12.2. General documentation

The following documentation describing the rolling stock shall be provided:

- General drawings.
- Electrical, pneumatic and hydraulic diagrams, control-circuit diagrams necessary to explain the function and operation of the concerned systems.
- Description of computerised onboard systems including description of functionality, specification of interfaces and data processing and protocols.
- Weight balance with hypothesis on load conditions considered, as required in clause 4.2.2.10.
- Axle load and spacing of axles, as required in clause 4.2.3.2.
- Test report concerning running dynamic behaviour, including the test track quality recording, as required in clause 4.2.3.4.2.
- The hypothesis taken to evaluate the loads due to bogie running, as required in clause 4.2.3.5.1.
- Braking performance, as required in clause 4.2.4.5.
- The presence and type of toilets in a unit, the characteristics of the flushing medium, if it is not clean water, the nature of the treatment system for released water and the standards against which conformity has been assessed, as required in clause 4.2.5.1.
- Provisions taken in relation with the selected range of environmental parameters if different than the nominal one, as required in clause 4.2.6.
- Traction performance, as required in clause 4.2.8.1.1.
- Hypothesis and data considered for the compatibility study for AC systems, as required in clause 4.2.8.2.7.
- The number of pantographs simultaneously in contact with the overhead contact line equipment (OCL), their spacing and the OCL design distance type (A, B or C) used for assessment tests, as required in clause 4.2.8.2.9.7.

**▼ B**

## 4.2.12.3. Documentation related to maintenance

Maintenance is a set of activities intended to keep a functional unit in, or to restore it to, a state in which it can perform its required function, ensuring continued integrity of safety systems and compliance with applicable standards (definition as per standard EN 13306).

The following information necessary to undertake maintenance activities on rolling stock shall be provided:

- The maintenance design justification file: explains how maintenance activities are defined and designed in order to ensure that the rolling stock characteristics will be kept within acceptable limits of use during its lifetime.

The file shall give input data in order to determine the criteria for inspection and the periodicity of maintenance activities.

- The maintenance description file: explains how maintenance activities shall be performed.

## 4.2.12.3.1. The maintenance design justification file

The maintenance design justification file shall contain:

- precedents, principles and methods used to design the maintenance of the unit,
- utilisation profile: Limits of the normal use of the unit (e.g. km/month, climatic limits, authorised types of loads etc.),
- relevant data used to design the maintenance and origin of these data (return of experience),
- tests, investigations and calculations carried out to design the maintenance.

Resultant means (facilities, tools ...) needed for the maintenance are described in clause 4.2.12.3.2 'Maintenance documentation'.

## 4.2.12.3.2. The maintenance description file

The maintenance description file shall describe how maintenance activities shall be conducted.

Maintenance activities include all activities necessary such as inspections, monitoring, tests, measurements, replacements, adjustments, repairs.

Maintenance activities are split into:

- preventive maintenance; scheduled and controlled,
- corrective maintenance.

The maintenance description file shall include the following:

- Component hierarchy and functional description: The hierarchy sets up the boundaries of the rolling stock by listing all the items belonging to the product structure of that rolling stock and using an appropriate number of discrete levels. The lowest item of the hierarchy shall be a replaceable unit.
- Schematic circuit diagrams, connection diagrams and wiring diagrams.

**▼ B**

- Parts list: The parts list shall contain the technical descriptions of the spare parts (replaceable units) and their references, in order to allow identification and procurement of the correct spare parts.

The list shall include all parts specified for changing on condition, or which may require replacement following electrical or mechanical malfunction, or which will foreseeable require replacement after accidental damage (e.g. wind-screen).

Interoperability constituent shall be indicated and referenced to their corresponding declaration of conformity.

- The limit values for components which shall not be exceeded in service shall be stated; the possibility of specifying operational restrictions in degraded mode (limit value reached) is permitted.
- European legal obligations: where components or systems are subject to specific European legal obligations these obligations shall be listed.
- The structured set of tasks that include the activities, procedures, means proposed by the applicant to carry out the maintenance task.
- The description of the maintenance activities.

The following aspects have to be documented:

- Disassembly/assembly instructions drawings necessary for correct assembly/disassembly of replaceable parts
- Maintenance criteria
- Checks and tests
- Tools and materials required to undertake the task
- Consumables required to undertake the task
- Personal protective safety provision and equipment.
- Necessary tests and procedures to be undertaken after each maintenance operation before re-entry into service of rolling stock.
- Troubleshooting (fault diagnosis) manuals or facilities for all reasonably foreseeable situations; this includes functional and schematic diagrams of the systems or IT-based fault finding systems.

#### 4.2.12.4. Operating documentation

The technical documentation necessary to operate the unit is composed of:

- a description of operation in normal mode, including the operational characteristics and limitations of the unit (e.g. vehicle gauge, maximum design speed, axle loads, brake performance ...),
- a description of the various reasonably foreseeable degraded modes in case of safety significant failures of equipment or functions described in this TSI, together with the related acceptable limits and operating conditions of the unit that could be experienced.



**▼B**

This technical operating documentation shall be part of the technical file.

4.2.12.5. **Lifting diagram and instructions**

The documentation shall include:

- a description of procedures for lifting and jacking and related instructions,
- a description of interfaces for lifting and jacking.

4.2.12.6. **Rescue related descriptions**

The documentation shall include:

- a description of procedures for use of emergency measures and related necessary precautions to be taken, as e.g. use of emergency exits, entrance to RST for rescue, isolation of brakes, electrical earthing, towing,
- a description of effects when the described emergency measures are taken, e.g. reduction of brake performance after isolation of brakes.

4.3. **Functional and technical specification of the interfaces**4.3.1. *Interface with energy subsystem*

Table 7

**Interface with the energy subsystem**

Reference in the conventional rail LOC & PAS TSI		Reference in the conventional rail energy TSI	
Parameter	Clause	Parameter	Clause
Gauging	4.2.3.1	Pantograph gauge	Annex E
Operation within range of voltages and frequencies	4.2.8.2.2	Voltage and frequency	4.2.3
		Parameters relating to supply system performance:	
— Maximum current from OCL	4.2.8.2.4	— Maximum train current	4.2.4
— Power factor	4.2.8.2.6	— Power factor	4.2.4
— Maximum current at standstill	4.2.8.2.5	— Mean useful voltage	4.2.4
		— Current capacity DC systems trains at standstill	4.2.6
Regenerative brake with energy to OCL	4.2.8.2.3	Regenerative braking	4.2.7
Energy consumption measuring function	4.2.8.2.8	Electric energy consumption measuring	4.2.21
— Height of pantograph	4.2.8.2.9.1	Geometry of the overhead contact line	4.2.13
— Pantograph head geometry	4.2.8.2.9.2		
— Pantograph head geometry	4.2.8.2.9.2	Free passage gauge of pantographs	4.2.14
— Gauge	4.2.3.1		
Contact strip material	4.2.8.2.9.4	Contact wire material	4.2.18
Pantograph static contact force	4.2.8.2.9.5	Mean contact force	4.2.15

**▼B**

Reference in the conventional rail LOC & PAS TSI		Reference in the conventional rail energy TSI	
Parameter	Clause	Parameter	Clause
Pantograph contact force and dynamic behaviour	4.2.8.2.9.6	Dynamic behaviour and quality of current collection	4.2.16
Arrangements of pantographs	4.2.8.2.9.7	Pantograph spacing used for the design of OCL	4.2.17
Running through phase or system separation section	4.2.8.2.9.8	Separation sections: — phase — system	4.2.19 4.2.20
Electrical protection of the train	4.2.8.2.10	Electrical protection coordination arrangements	4.2.8
System energy disturbances for AC systems	4.2.8.2.7	Harmonics and dynamic effects	4.2.9

4.3.2. *Interface with infrastructure subsystem*

Table 8

**Interface with the infrastructure subsystem**

Reference in the conventional rail LOC & PAS TSI		Reference in the conventional rail infrastructure TSI	
Parameter	Clause	Parameter	Clause
Rolling stock kinematic gauge	4.2.3.1.	Minimum structure gauge	4.2.4.1
		Distance between track centres	4.2.4.2
		Minimum radius of vertical curve	4.2.4.5
Axle load parameter	4.2.3.2.1	Track resistance to vertical loads	4.2.7.1
		Lateral track resistance	4.2.7.3
		Resistance of bridges to traffic loads	4.2.8.1
		Equivalent vertical loading for earthworks and earth pressure effects	4.2.8.2
		Resistance of existing bridges and earthworks to traffic loads	4.2.8.4
Running dynamic behaviour	4.2.3.4.2.	Cant deficiency	4.2.5.4
Running dynamic limit values for track loading	4.2.3.4.2.2	Track resistance to vertical loads	4.2.7.1
		Lateral track resistance	4.2.7.3
Equivalent conicity	4.2.3.4.3	Equivalent conicity	4.2.5.5
Geometrical characteristics of wheelset	4.2.3.5.2.1	Nominal track gauge	4.2.5.1
Geometrical characteristics of wheels	4.2.3.5.2.2	Rail head profile for plain line	4.2.5.6
Variable gauge wheelsets	4.2.3.5.2.3	In-service geometry of switches and crossings	4.2.6.2

**▼B**

Reference in the conventional rail LOC & PAS TSI		Reference in the conventional rail infrastructure TSI	
Parameter	Clause	Parameter	Clause
Minimum curve radius	4.2.3.6	Minimum radius of horizontal curve	4.2.4.4
Maximum average deceleration	4.2.4.5.1	Longitudinal track resistance	4.2.7.2
		Actions due to traction and braking	4.2.8.1.4
Slipstream effects	4.2.6.2.1	Resistance of new structures over or adjacent to tracks	4.2.8.3
Head pressure pulse	4.2.6.2.2	Maximum pressure variations in tunnels	4.2.11.1
Maximum pressure variations in tunnels	4.2.6.2.3	Piston effects in underground stations	4.2.11.2
	4.2.6.2.4	Distance between track centres	4.2.4.2
Crosswind	4.2.6.2.5	Effect of crosswinds	4.2.11.6
Toilet discharge system	4.2.11.3	Toilet discharge	4.2.13.1
Exterior cleaning through a washing plant	4.2.11.2.2	Train external cleaning facilities,	4.2.13.2
Water refilling equipment:			
Interface for water refilling	4.2.11.4 4.2.11.5	Water restocking,	4.2.13.3
Refuelling equipment	4.2.11.7	Refuelling	4.2.13.5
Special requirements for stabling of trains	4.2.11.6	Electric shore supply	4.2.13.6

4.3.3. *Interface with operation subsystem*

Table 9

**Interface with the operation subsystem**

Reference in the conventional rail LOC & PAS TSI		Reference in the conventional rail operation TSI	
Parameter	Clause	Parameter	Clause
Rescue coupling	4.2.2.2.4	Contingency arrangements	4.2.3.6.3
Axle load parameter	4.2.3.2	Train composition	4.2.2.5
Braking performance	4.2.4.5	Minimum requirements of the braking system	4.2.2.6.1
External front and rear lights	4.2.7.1	Train visibility	4.2.2.1
Horn	4.2.7.2	Train audibility	4.2.2.2
External visibility	4.2.9.1.3	Signal sighting	4.2.2.8 (*)
Optical characteristics of the windscreen	4.2.9.2.2		
Internal lighting	4.2.9.1.8		
Driver's activity control function	4.2.9.3.1	Driver vigilance	4.2.2.9 <sup>19</sup>
Recording device	4.2.9.6	Data recording	4.2.3.5.2

(\*) In the forthcoming revision of the OPE TSI.

**▼B**4.3.4. *Interface with the control, command and signalling subsystem***▼M1**

Table 10

**Interface with the control-command and signalling subsystem**

Reference Conventional Rail LOC & PAS TSI		Reference Rail CCS TSI	
Parameter	Clause	Parameter	Clause
Rolling stock characteristics compatible with train detection system based on track circuits	4.2.3.3.1.1	Vehicle geometry Vehicle design Isolating emissions EMC	Specification referenced in Annex A, Index 77 of CCS TSI
Rolling stock characteristics compatible with train detection system based on axle counters	4.2.3.3.1.2	Vehicle geometry Wheel geometry Vehicle design EMC	Specification referenced in Annex A, Index 77 of CCS TSI
Rolling stock characteristics compatible with loop equipment	4.2.3.3.1.3	Vehicle design	Specification referenced in Annex A, Index 77 of CCS TSI
Emergency braking command	4.2.4.4.1	On-board ETCS functionality	4.2.2
Emergency braking performance	4.2.4.5.2	Guaranteed train braking performance and characteristics	4.2.2
External visibility	4.2.9.1.3	Visibility of track-side control-command objects	4.2.15

**▼B**4.3.5. *Interface with the telematic application for passengers subsystem*

Table 11

**Interface with the telematic application for passengers subsystem**

Reference in the conventional rail LOC & PAS TSI		Reference in the telematic application for passengers draft TSI	
Parameter	Clause	Parameter	Clause
Customer information (PRM)	4.2.5	Onboard device display	4.2.13.1
Public address system	4.2.5.2	Automatic voice and announcement	4.2.13.2
Customer information (PRM)	4.2.5		

4.4. **Operating rules**

In light with the essential requirements mentioned in Section 3, the provisions for operation of rolling stock in the scope of this TSI are described in:

- Clause 4.3.3 ‘Interface with operation subsystem’, which refers to the relevant clauses of this TSI in Section 4.2,
- Clause 4.2.12 ‘Documentation for operation and maintenance’.

Operating rules are developed under the railway undertaking safety management system.

**▼ B**

In particular, operating rules are necessary to ensure that a train stopped on a gradient as specified in clauses 4.2.4.2.1 and 4.2.4.5.5 of this TSI (requirements related to braking) will be immobilised. The operating rules for use of the public address system, the passenger alarm, the emergency exits, the operation of the access doors are elaborated with consideration of the relevant provisions of this TSI and of the documentation for operation.

The safety rules for trackside workers or passengers on platforms are developed with consideration of the relevant provisions of this TSI and of the documentation for operation.

The technical operating documentation described in clause 4.2.12.4 gives the rolling stock characteristics to be considered in order to define the operating rules in degraded mode.

Procedures for lifting and rescue are established, including the method as well as the means of recovering a derailed train or a train that is unable to move normally with consideration of the provisions for lifting and jacking are described in clause 4.2.2.6 and 4.2.12.5 of this TSI; provisions related to the braking system for rescue are described in clause 4.2.4.10 and 4.2.12.6 of this TSI.

#### 4.5. **Maintenance rules**

In light with the essential requirements mentioned in Section 3, the provisions for maintenance of rolling stock in the scope of this TSI are described in:

- Clause 4.2.11 ‘Servicing’,
- Clause 4.2.12 ‘Documentation for operation and maintenance’.

Other provisions in the Section 4.2 (clauses 4.2.3.4 and 4.2.3.5) specify for particular characteristics the limit values that have to be verified during maintenance activities.

From the information mentioned above and provided in the clause 4.2, the appropriate tolerances and intervals to ensure compliance with the essential requirements throughout the lifetime of the rolling stock are defined at operational level (not in the scope of the assessment against this TSI); this activity includes:

- the definition of the in-service values where they are not specified in this TSI, or where operating conditions allow the use of different in-service limit values than those specified in this TSI,
- the justification of the in-service values, by providing the equivalent information to those required in clause 4.2.12.3.1 ‘The maintenance design justification file’.

On the basis of the information mentioned above in this clause, a maintenance plan is defined at operational level (not in the scope of the assessment against this TSI), consisting in a structured set of maintenance tasks that include the activities, tests and procedures, means, maintenance criteria, periodicity, working time required to carry out the maintenance tasks.

**▼B****4.6. Professional competencies**

The professional competencies of staff required for the operation of rolling stock in the scope of this TSI are partly covered by the TSI on operations and Directive 2007/59/EC of the European Parliament and of the Council <sup>(1)</sup>.

**4.7. Health and safety conditions**

The provisions for health and safety of staff required for the operation and maintenance of rolling stock in the scope of this TSI are covered by the essential requirements No. 1.1, 1.3, 2.5.1, 2.6.1 (as numbered in Directive 2008/57/EC); the table in clause 3.2 mentions the technical clauses of this TSI in relation to these essential requirements.

In particular, the following provisions of the Section 4.2 specify provisions for health and safety of staff:

- Clause 4.2.2.2.5: Staff access for coupling and uncoupling.
- Clause 4.2.2.5: Passive safety.
- Clause 4.2.2.8: Staff and freight access doors.
- Clause 4.2.6.2.2: Slipstream effects on workers at trackside.
- Clause 4.2.7.2.2: Warning horn sound pressure.
- Clause 4.2.8.4: Protection against electrical hazards.
- Clause 4.2.9: Driver's cab.
- Clause 4.2.10: Fire safety and evacuation.

**4.8. European register of authorised types of vehicles**

In accordance with Article 34(2)(a) of Directive 2008/57/EC, the TSI shall define the technical characteristics of rolling stock, to be included in the European register of authorised types of vehicles.

The main characteristics of the rolling stock to be recorded in the European register of authorised types of vehicles are shown in table 12.

Information to be included in the European register required for other subsystems are set in the other relevant TSIs.

Table 12

**Data to be recorded in the European register of authorised types of vehicles**

Characteristic of the rolling stock	Clause	Type of the data to be recorded
Condition of use (the defined formations the rolling stock is certified for)	4.1.2	The formation, unit, fixed or predefined formation, multiple operation
	4.1.3	Technical category
End coupling	4.2.2.2.3	Type of mechanical coupling and the nominal maximum design value of tensile and compressive forces
Rolling stock gauge	4.2.3.1	The reference kinematic gauge (GA, GB or GC) the rolling stock complies with including national gauges smaller than GC

<sup>(1)</sup> OJ L 315, 3.12.2007, p. 51.

**▼B**

Characteristic of the rolling stock	Clause	Type of the data to be recorded
Mass	4.2.2.10	The design mass of the unit in working order The design mass of the unit under normal payload The highest axle load of an individual axle for each load condition
Rolling stock characteristics for the compatibility with train detection systems	4.2.3.3.1	compatibility with train detection system based on track circuits or compatibility with train detection system based on axle counters or compatibility with loop equipment
Quasi-static guiding force	4.2.3.4.2.2 and 7.5.1.2	Estimated value (after test and recalculation if relevant)
Braking performance in emergency brake for normal and degraded conditions (lowest performance for each on load condition)	4.2.4.5.2	Deceleration profile (deceleration = F(speed)) Equivalent response time
Additional brake systems installed	4.2.4	Regenerative brake, magnetic track brake, eddy current track brake
Brake thermal capacity	4.2.4.5.4	Conformity to reference case (yes/no) — if no: slope and length of gradient
Parking brake performance	4.2.4.5.5	Gradient
Internal air quality/emergency ventilation	4.2.5.9	The duration the forced ventilation is able to keep the carbon dioxide level below 10 000 ppm (registration only required if ventilation is ensured through battery supply)
Environmental conditions	4.2.6.1	The selected range of environmental conditions parameters (temperature, snow conditions, altitude)
Speed	4.2.8.1.2	The design maximum speed
Power supply	4.2.8.2.2	The system voltage and frequency the rolling stock is designed for
Maximum current	4.2.8.2.4	The maximum current the rolling stock is limited to draw
Maximum current at standstill for DC systems	4.2.8.2.5	The maximum current at standstill per pantograph (if higher than what is specified in clause 4.2.6 of the CR ENE TSI)
Energy consumption measuring function	4.2.8.2.8	The presence of a measuring unit (yes/no)
Type of Pantograph	4.2.8.2.9.2	The type(s) of pantograph head geometry the rolling stock is equipped with
Design fire category	4.2.10.1	A, B, or freight locomotive

**▼B**

## 5. INTEROPERABILITY CONSTITUENTS

5.1. **Definition**

According to Article 2(f) of Directive 2008/57/EC, the interoperability constituents are ‘any elementary component, group of components, subassembly or complete assembly of equipment incorporated or intended to be incorporated into a subsystem upon which the interoperability of the trans-European conventional rail system depends on directly or indirectly.’

The concept of a ‘constituent’ covers both tangible objects and intangible objects such as software.

Interoperability constituents (IC) described in Section 5.3 below are constituents:

— Whose specification refers to a requirement defined in Section 4.2 of this TSI. The reference to the relevant clause of the Section 4.2 is given in Section 5.3; it defines how the interoperability of the trans-European conventional rail system depends on the particular constituent.

When a requirement is identified in Section 5.3 as being assessed at IC level, an assessment for the same requirement at subsystem level is not required.

— Whose specification may need additional requirements, such as interface requirements; these additional requirements are also specified in Section 5.3.

— And whose assessment procedure, independently of the related subsystem is described in Section 6.1

The area of use of an interoperability constituent shall be stated and demonstrated as described for each of them in Section 5.3.

5.2. **Innovative solution**

As stated in clause 4.1.1 of this TSI, innovative solutions may require new specification and/or new assessment methods. Such specifications and assessment methods shall be developed by the process described in clause 6.1.3 whenever an innovative solution is envisaged for an interoperability constituent.

5.3. **Interoperability constituent specification**

The interoperability constituents are listed and specified below:

5.3.1. *Rescue couplers*

A rescue coupler shall be designed and assessed for an area of use defined by:

- the type of end coupling it is capable of being interfaced with,
- the tensile and compressive forces it is capable of withstanding,
- the way it is intended to be installed on the rescuing unit.

A rescue coupler shall comply with the requirements expressed in clause 4.2.2.2.4 of this TSI. These requirements shall be assessed at IC level.



**▼ B**5.3.2. *Wheels*

A wheel shall be designed and assessed for an area of use defined by:

- geometrical characteristics: nominal tread diameter,
- mechanical characteristics: maximum vertical static force, maximum speed and service life,
- thermo mechanical characteristics: maximum braking energy.

A wheel shall comply with the requirements on geometrical, mechanical and thermo mechanical characteristics defined in clause 4.2.3.5.2.2; these requirements shall be assessed at IC level.

5.3.3. *WSP (wheel slide protection system)*

An IC 'WSP system' shall be designed and assessed for an area of use defined by:

- a brake system of pneumatic type.

*Note:* The WSP is not considered as an IC for other types of brake system such as hydraulic, dynamic and mixed braking systems, and this clause does not apply in that case.

- the maximum operating speed.

A WSP system shall comply with the requirements related to the wheel slide protection system expressed in clause 4.2.4.6.2 of this TSI.

5.3.4. *Head lights*

A head light is designed and assessed without any limitation concerning its area of use.

A head light shall comply with requirements concerning the colour and the luminous intensity defined in clause 4.2.7.1.1. These requirements shall be assessed at IC level.

5.3.5. *Marker lights*

A marker light is designed and assessed without any limitation concerning its area of use.

A marker light shall comply with requirements concerning the colour and the luminous intensity defined in clause 4.2.7.1.2. These requirements shall be assessed at IC level.

5.3.6. *Tail lights*

A tail light is designed and assessed without any limitation concerning its area of use.

A tail light shall comply with the requirements concerning the colour and the luminous intensity defined in clause 4.2.7.1.3. These requirements shall be assessed at IC level.

5.3.7. *Horns*

A horn is designed and assessed without any limitation concerning its area of use.

**▼B**

A horn shall comply with the requirements concerning the soundings of signals defined in clause 4.2.7.2.1. These requirements shall be assessed at IC level.

5.3.8. *Pantograph*

A pantograph shall be designed and assessed for an area of use defined by:

- the type of voltage system(s), as defined in clause 4.2.8.2.1,
- one of the 2 gauges defined by the pantograph head geometry specified in clause 4.2.8.2.9.2,
- the current capacity, as defined in clause 4.2.8.2.4,
- the maximum current at standstill per contact wire of the overhead contact line for DC systems,

*Note:* The maximum current at standstill, as defined in clause 4.2.8.2.5, shall be compatible with the value above, considering the characteristics of the overhead contact line (1 or 2 contact wires).

- the maximum operating speed: assessment of the maximum operating speed shall be performed as defined in clause 4.2.8.2.9.6.

The requirements specified in the list above shall be assessed at IC level.

The working range in height of pantograph specified in clause 4.2.8.2.9.1.2, the pantograph head geometry specified in clause 4.2.8.2.9.2, the pantograph current capacity specified in clause 4.2.8.2.9.3, the pantograph static contact force specified in clause 4.2.8.2.9.5 and the dynamic behaviour of the pantograph itself specified in clause 4.2.8.2.9.6 shall also be assessed at IC level.

5.3.8.1. *Contact strips*

The contact strips are the replaceable parts of the pantograph head which are in contact with the contact wire.

Contacts strips shall be designed and assessed for an area of use defined by:

- their geometry, as defined in clause 4.2.8.2.9.4.1,
- the material of the contact strips, as defined in clause 4.2.8.2.9.4.2,
- the type of voltage system(s), as defined in clause 4.2.8.2.1,
- the current capacity, as defined in clause 4.2.8.2.4,
- the maximum current at standstill for DC systems, as defined in clause 4.2.8.2.5.

The requirements specified above in this clause shall be assessed at IC level.

In addition, for contact strips made of carbon or of impregnated carbon, a conformity assessment as specified in clause 6.1.2.2.7 shall be carried out.

**▼B**5.3.9. *Main circuit breaker*

A main circuit breaker shall be designed and assessed for an area of use defined by:

- the type of voltage system(s), as defined in clause 4.2.8.2.1,
- the current capacity, as defined in clause 4.2.8.2.4 (maximum current) and in clause 4.2.8.2.10 (maximum fault current).

The requirements specified in the clauses above shall be assessed at IC level.

The tripping shall be immediate (no intentional delay) as specified in the Annex K of the CR ENE TSI referred to in clause 4.2.8.2.10 (maximum acceptable value are given in Note 2 of Annex K); it shall be assessed at the IC level.

5.3.10. *Toilet discharge connection*

A toilet discharge connection is designed and assessed without any limitation concerning its area of use.

A toilet discharge connection shall comply with requirements concerning the dimensions as defined in clause 4.2.11.3.

5.3.11. *Inlet connection for water tanks*

An inlet connection for water tanks is designed and assessed without any limitation concerning its area of use.

An inlet connection for water tanks shall comply with requirements concerning the dimensions as defined in clause 4.2.11.5.

## 6. ASSESSMENT OF CONFORMITY OR SUITABILITY FOR USE AND 'EC' VERIFICATION

6.1. **Interoperability constituents**6.1.1. *Conformity assessment*

An EC declaration of conformity or suitability for use, in accordance with Article 13(1) of and Annex IV to Directive 2008/57/EC, shall be drawn up by the manufacturer or his authorised representative established in the Union before placing an interoperability constituent on the market.

The assessment of conformity or suitability for use of an interoperability constituent shall be performed according to the prescribed module(s) of that particular constituent specified in clause 6.1.2 of this TSI.

**Modules for EC certification of conformity of interoperability constituents**

Module CA	Internal production control
Module CA1	Internal production control plus product verification by individual examination
Module CA2	Internal production control plus product verification at random intervals
Module CB	EC-type examination
Module CC	Conformity to type based on internal production control
Module CD	Conformity to type based on quality management system of the production process

**▼B**

Module CA	Internal production control
Module CF	Conformity to type based on product verification
Module CH	Conformity based on full quality management system
Module CH1	Conformity based on full quality management system plus design examination
Module CV	Type validation by in-service experience (suitability for use)

These modules are described in a separate decision of the Commission.

Where a particular procedure shall be used for the assessment, in addition to the requirements expressed in the clause 4.2 of this TSI, this is specified in the clause 6.1.2.2 below.

Notified bodies eligible to assess the interoperability constituents specified in this TSI shall be authorised to assess the conventional rail rolling stock subsystem and/or the pantograph.

#### 6.1.2. *Conformity assessment procedures*

##### 6.1.2.1. *Conformity assessment modules*

The manufacturer or his authorised representative established within the Community shall choose one of the modules or module combinations indicated in the following table according to the required constituent.

Clause	Constituents to be assessed	Module CA	Module CA1 or CA2	Module CB + CC	Module CB + CD	Module CB + CF	Module CH	Module CH1
5.3.1	Towing couplers for rescue		X (*)		X	X	X (*)	X
5.3.2	Wheels		X (*)		X	X	X (*)	X
5.3.3	Wheel slide protection system		X (*)		X	X	X (*)	X
5.3.4	Head lights		X (*)	X	X		X (*)	X
5.3.5	Marker lights		X (*)	X	X		X (*)	X
5.3.6	Tail lights		X (*)	X	X		X (*)	X
5.3.7	Horns		X (*)	X	X		X (*)	X
5.3.8	Pantograph		X (*)		X	X	X (*)	X
5.3.8.1	Pantograph contact strips		X (*)		X	X	X (*)	X
5.3.9	Main circuit breaker		X (*)		X	X	X (*)	X
5.3.10	Toilet discharge connection	X		X			X	
5.3.11	Inlet connection for water tanks	X		X			X	

(\*) Modules CA1, CA2 or CH may be used only in the case of products placed on the market, and therefore developed, before the entry into force of this TSI, provided that the manufacturer demonstrates to the notified body that design review and type examination were performed for previous applications under comparable conditions, and are in conformity with the requirements of this TSI; this demonstration shall be documented, and is considered as providing the same level of proof as module CB or design examination according to module CH1.

#### 6.1.2.2. *Particular assessment procedures for interoperability constituents*

##### 6.1.2.2.1. *Wheel slide protection system (clause 5.3.3)*

The wheel slide protection system shall be verified according to the methodology defined in EN 15595:2009 clause 5; when reference is made to the clause 6.2 of EN 15595:2009 'overview of required test programmes', only the clause 6.2.3 applies, and it applies to all WSP systems.

**▼B**

- 6.1.2.2.2. Head lights (clause 5.3.4)  
The colour of headlamps shall be tested in accordance with EN 15153-1:2007, clause 6.1.  
  
The luminous intensity of headlamps shall be tested in accordance with EN 15153-1:2007 clause 6.2.
- 6.1.2.2.3. Marker lights (clause 5.3.5)  
The colour of marker lamps shall be tested in accordance with EN 15153-1:2007, clause 6.1.  
  
The luminous intensity of marker lamps shall be tested in accordance with EN 15153-1:2007, clause 6.2.
- 6.1.2.2.4. Tail lights (clause 5.3.6)  
The colour of tail lamps shall be tested in accordance with EN 15153-1:2007, clause 6.1.  
  
The luminous intensity of tail lamps shall be tested in accordance with EN 15153-1:2007, clause 6.2.
- 6.1.2.2.5. Horn (clause 5.3.7)  
Sound pressure levels of the warning horn shall be measured and verified in accordance with EN 15153-2:2007, clause 5.
- 6.1.2.2.6. Pantograph (clause 5.3.8)  
For pantographs for DC systems, the maximum current at standstill per contact wire shall be verified in the following conditions:  
  
— the pantograph shall be in contact with 1 copper contact wire,  
  
— the pantograph shall apply a static contact force as defined in clause 7.1 of EN 50367:2006,  
  
and the temperature of the contact point monitored continuously during a test of 30 minutes shall not exceed the values given in clause 5.1.2 of EN 50119:2009.  
  
For all pantographs, the static contact force shall be verified in accordance with clause 6.3.1 of EN 50206-1:2010.  
  
The dynamic behaviour of the pantograph regarding current collection shall be assessed by simulation according to EN50318:2002.  
  
The simulations shall be made using at least two different TSI compliant <sup>(1)</sup> types of overhead contact line for the appropriate speed <sup>(2)</sup> and supply system, up to the design speed of the proposed Interoperability Constituent pantograph.  
  
It is permitted to perform the simulation using types of overhead contact line that are under the process of IC certification, provided that they fulfil the other requirements of CR ENE TSI.  
  
The simulated current collection quality shall be in accordance with clause 4.2.8.2.9.6 for uplift, mean contact force and standard deviation for each of the overhead contact lines.  
  
If the simulation results are acceptable, a site dynamic test shall be made using a representative section of one of the two types of overhead contact line used in the simulation.

**▼B**

The interaction characteristics shall be measured in accordance with EN50317:2002.

The tested pantograph shall be mounted on a rolling stock producing a mean contact force within the upper and lower limits as required by clause 4.2.8.2.9.6 up to the design speed of the pantograph. The tests shall be conducted in both directions of travel and shall include track sections with low contact wire height (defined as between 5,0 to 5,3 m) and track sections with high contact wire height (defined as between 5,5 to 5,75 m).

The tests shall be performed for a minimum of 3 speed increments up to and including the design speed of the tested pantograph.

The interval between successive tests shall be no greater than 50 km/h.

The measured current collection quality shall be in accordance with clause 4.2.8.2.9.6 for uplift, and either mean contact force and standard deviation or percentage of arcing.

If all the assessments above are passed successfully, the tested pantograph design shall be considered as compliant to the TSI regarding quality of current collection.

For the use of a pantograph holding an EC declaration of verification on various designs of rolling stock, additional tests required at rolling stock level regarding quality of current collection are specified in clause 6.2.2.2.14.

*Notes:*

- (<sup>1</sup>) i.e. overhead contact lines holding a declaration as an interoperability constituent according to CR or HS TSIs.
- (<sup>2</sup>) i.e. the speed of the two types of overhead contact line shall be at least equal to the design speed of the simulated pantograph.

#### 6.1.2.2.7. Contact strips (clause 5.3.8.1)

Contact strips of plain carbon or impregnated carbon shall be verified as specified in clauses 5.2.2, 5.2.3, 5.2.4, 5.2.6 and 5.2.7 of EN 50405:2006.

Contact strips of other material: the verification is an open point.

#### 6.1.2.3. Project phases where assessment is required

It is detailed in Annex H of this TSI in which phases of the project an assessment shall be done for the requirements applicable to the interoperability constituents:

- Design and development phase:
  - Design review and/or design examination.
  - Type test: test to verify the design, if and as defined in the Section 4.2.
- Production phase: routine test to verify the conformity of production.

The entity in charge of the assessment of the routine tests is determined according to the assessment module chosen.

The Annex H is structured according to the Section 4.2; the requirements and their assessment applicable to the interoperability constituents are identified in the Section 5.3 by reference to certain clauses of the Section 4.2; where relevant, a reference to a sub-clause of the clause 6.1.2.2 above is also given.

**▼ B**6.1.3. *Innovative solutions*

If an innovative solution (as defined in clause 4.1.1) is proposed for an interoperability constituent as defined in Section 5.2, the manufacturer or his authorised representative established within the Community shall state the deviations from the relevant provision of this TSI and submit them to the Commission for analysis.

In case the analysis results in a favourable opinion, the appropriate functional and interface specifications as well as the assessment method which are necessary to be included in the TSI in order to allow the use of this constituent will be developed.

The appropriate functional and interface specifications and the assessment methods so produced shall be incorporated in the TSI by the revision process.

By the notification of a decision of the Commission, taken in accordance with Article 29 of Directive 2008/57/EC, the innovative solution may be permitted to be used before being incorporated into the TSI by the revision process.

6.1.4. *Constituent requiring EC declarations against the HS RST TSI and against this TSI*

This clause covers the case of an interoperability constituent subject to assessment against this TSI, and:

- which has also to be assessed against the HS RST TSI, or
- which has already been granted an EC declaration of conformity or suitability for use against the HS RST TSI.

The parameters specifying the interoperability constituents which are covered in both TSIs, and are equally specified, are identified in the clause 6.2.5 of this TSI.

In that case, the interoperability constituents do not need to be reassessed according to this TSI; the assessment performed against the HS RST TSI is deemed to be recognised as valid for both TSIs.

This applies to the following interoperability constituents:

- head lights,
- marker lights,
- tail lights,
- horn,
- pantograph, provided that the condition stipulated in the clause 6.2.5 is met,
- pantograph contact strip,
- toilet discharge connection,
- connection for water tanks.

The EC declaration of conformity or suitability for use to this TSI may refer to the EC declaration of conformity or suitability for use to the HS RST TSI for the interoperability constituents listed above.

**▼B**6.1.5. *Assessment of suitability for use*

Assessment of suitability for use according to the type validation of in-service experience procedure (module CV) is required for the following interoperability constituents:

- wheels,
- wheel slide protection system.

Prior to commencing in-service tests, a suitable module (CB or CH) shall be used to certify the design of the constituent.

6.2. **Rolling stock subsystem**6.2.1. *EC verification (general)*

EC verification procedures are described in Annex VI of Directive 2008/57/EC.

The EC verification process of a RST unit shall be performed according to one or a combination of the following modules, as defined in clause 6.2.2 of this TSI.

**Modules for the EC verification of subsystems**

Module SB	EC-type examination
Module SD	EC verification based on quality management system of the production process
Module SG	EC verification based on unit verification
Module SF	EC verification based on product verification
Module SH1	EC verification based on full quality management system plus design examination

These modules are described in a separate Commission Decision.

Where a particular procedure shall be used for the assessment, in addition to the requirements expressed in the clause 4.2 of this TSI, this is specified in the clause 6.2.2.2 below.

When a first step assessment covering the design stage or the design and production stages is applied for by the applicant, the notified body of his choice shall issue the intermediate statement verification (ISV) and the EC declaration of intermediate subsystem conformity shall be drawn up.

6.2.2. *Conformity assessment procedures (modules)*6.2.2.1. **C o n f o r m i t y   a s s e s s m e n t   m o d u l e s**

The applicant shall choose one of the following combinations of modules:

(SB + SD) or (SB + SF) or (SH1) for each concerned subsystem (or part of subsystem).

The assessment shall then be performed according to the combination of modules chosen.

Where several EC verifications (e.g. against several TSIs addressing the same subsystem) require verification based on the same production assessment (module SD or SF), it is allowed to combine several SB module assessments with one production module assessment (SD or SF). In this case, ISVs shall be issued for the design and development phases according to module SB.



**▼B**

If module SB is used, the validity of the type examination certificate shall be indicated in accordance with the provisions for phase B of clause 7.1.3 'Rules related to EC verification', of this TSI.

6.2.2.2. Particular assessment procedures for subsystems

6.2.2.2.1. Load conditions and weighted mass (clause 4.2.2.10)

The load condition 'design mass in working order' shall be measured in accordance with the method for vehicle weighing set out in EN 14363:2005 clause 4.5 for every (manufactured) vehicle.

6.2.2.2.2. Gauging (clause 4.2.3.1)

The unit gauge shall be assessed using the kinematic method as described in clause B.3 of EN 15273-2:2009.

6.2.2.2.3. Wheel load (clause 4.2.3.2.2)

The wheel load shall be measured as specified in EN 14363:2005, clause 4.5 considering the load condition 'design mass in working order'.

6.2.2.2.4. Braking — Safety requirements (clause 4.2.4.2.2)

The demonstration of compliance with the safety requirements expressed in the table 6 of the clause 4.2.4.2.2 shall be performed as follows:

- The scope of this assessment shall be strictly limited to the rolling stock design, considering that operation, test and maintenance are performed according to the rules defined by the applicant (as described in the technical file).

*Note:* When defining the test and maintenance requirements, the safety level to be met has to be taken into account by the applicant (consistency); the demonstration of compliance covers also test and maintenance requirements.

Other subsystems and human factors (errors) shall not be considered.

- All assumptions considered for the mission profile shall be clearly documented in the demonstration.

The compliance with the requirement specified for the hazards No 1 and No 2 of the table 6 in clause 4.2.4.2 shall be demonstrated by one of the two following methods:

1. Application of a harmonised criterion expressed in a tolerable hazard rate of  $10^{-9}$  per hour.

This criterion is in accordance with Regulation (EC) No 352/2009 (hereafter called 'CSM on RA') Annex I, clauses 2.5.4.

The applicant shall demonstrate compliance with the harmonised criterion by applying Annex I-3 of the CSM on RA. The following principles may be used for the demonstration: similarity with reference system(s); application of codes of practice; application of the probabilistic approach.

The applicant shall designate the assessment body supporting the demonstration he will provide: notified body selected for the RST subsystem or assessment body as defined in the CSM on RA.

**▼B**

The assessment shall be documented in the EC certificate issued by the notified body, or in the EC declaration of verification issued by the applicant.

The EC declaration of verification shall mention the compliance to this criterion, and shall be recognised in all Member States.

In the case of additional authorisations for placing in service of vehicles, the Article 23(1) of Directive 2008/57/EC applies.

or

2. Application of a risk evaluation and assessment in accordance with the CSM on RA.

The EC declaration of verification shall mention the use of this method.

The applicant shall designate the assessment body supporting the demonstration he will provide, as defined in the CSM on RA.

A safety assessment report shall be provided documenting the risk evaluation and assessment which has been performed; the report shall include:

- risk analysis,
- risk acceptance principle, risk acceptance criterion and safety measures to be implemented,
- demonstration of compliance with the risk acceptance criterion and with the safety measures to be implemented.

The safety assessment report shall be taken into account by the national safety authority in the concerned Member State, in accordance with Section 2.5.6 of Annex I and Article 7(2) of the CSM on RA.

In the case of additional authorisations for placing in service of vehicles, Article 7(4) of the CSM on RA applies for the recognition of the safety assessment report in other Member States.

#### 6.2.2.2.5. Emergency braking (clause 4.2.4.5.2)

The braking performance which is subject to a test is the stopping distance as defined in EN 14531-1:2005 clause 5.11.3. The deceleration is evaluated from the stopping distance.

Tests shall be carried out on dry rails at the following initial speeds (if lower than the maximum speed): 30 km/h; 80 km/h; 120 km/h; 140 km/h; 160 km/h; 200 km/h; maximum design speed of the unit.

Tests shall be carried out for the load conditions of the unit 'design mass in working order' and 'design mass under normal payload' (as defined in clause 4.2.2.10).

Test results shall be evaluated by a methodology that takes into account the following aspects:

- correction of the raw data,
- repeatability of the test: in order to validate a test result, the test is repeated several times; the absolute difference between results and the standard deviation are evaluated.

**▼B**

- 6.2.2.2.6. Service braking (clause 4.2.4.5.3)
- The braking performance which is subject to a test is the stopping distance as defined in EN 14531-1:2005 clause 5.11.3. The deceleration is evaluated from the stopping distance.
- Tests shall be carried out on dry rail at the initial speed equal to the maximum design speed of the unit, the load condition of the unit being one of those defined in the clause 4.2.2.10.
- Test results shall be evaluated by a methodology that takes into account the following aspects:
- correction of the raw data,
  - repeatability of the test: in order to validate a test result, the test is repeated several times; the absolute difference between results and the standard deviation are evaluated.
- 6.2.2.2.7. Wheel slide protection system (clause 4.2.4.6.2)
- If a unit is equipped with a WSP, a test of the unit in low adhesion conditions shall be carried out according to the clauses 6. 4 of the standard EN 15595:2009, in order to validate the performance of the WSP system (maximum extension of the stopping distance compared to stopping distance on dry rail) when integrated in the unit.
- 6.2.2.2.8. Sanitary systems (clause 4.2.5.1)
- In case the sanitary system allows the release of fluids to the environment (e.g. on the tracks), the assessment of conformity may be based on previous in-service testing when the following conditions are met:
- The results of the in-service tests were obtained on types of equipment which have an identical treatment method.
  - The conditions of test are similar as the ones that may be assumed for the unit under assessment, with regard to loading volumes, environmental conditions, and all other parameters which will influence the efficiency and effectiveness of the treatment process.
- If suitable in-service testing results are lacking, type tests shall be performed.
- 6.2.2.2.9. Internal air quality (clause 4.2.5.9 and clause 4.2.9.1.7)
- Conformity assessment of the CO<sub>2</sub>-levels is permitted to be established by calculation of fresh air ventilation volumes assuming an outside air quality containing 400 ppm CO<sub>2</sub> and an emission of 32 grams of CO<sub>2</sub> per passenger per hour. The number of passengers to be taken into account shall be derived from the occupation under the load condition 'design mass under normal payload', as stipulated in clause 4.2.2.10 of this TSI.
- 6.2.2.2.10. Slipstream effects on passengers on platform (clause 4.2.6.2.1)
- Conformity shall be assessed on the basis of full-scale tests under conditions specified in EN 14067-4:2005/A1:2009 clause 7.5.2. The measurements shall be performed on a platform of a height between 100 mm and 400 mm above top of rail.

**▼B**

- 6.2.2.2.11. Slipstream effects on workers at track side (clause 4.2.6.2.2)  
 Conformity shall be assessed on the basis of full-scale tests under conditions specified in EN 14067-4:2005/A1:2009 clause 8.5.2.
- 6.2.2.2.12. Head pressure pulse (clause 4.2.6.2.3)  
 Conformity shall be assessed on the basis of full-scale tests under conditions specified in EN 14067-4:2005/A1:2009 clause 5.5.2. Alternatively, and limited for speeds below 190 km/h, conformity may be assessed by means of either validated computational fluid dynamics (CFD) simulations as described in clause 5.3 of EN 14067-4:2005/A1:2009 or as an additional alternative conformity is permitted to be assessed by moving model tests as specified in EN 14067-4:2005/A1:2009 clause 5.4.3.
- 6.2.2.2.13. Maximum power and current from the overhead contact line (clause 4.2.8.2.4)  
 Conformity assessment shall be carried out in accordance with clause 14.3 of EN 50388:2005.
- 6.2.2.2.14. Power factor (clause 4.2.8.2.6)  
 Conformity assessment shall be carried out according to the clause 14.2 of EN 50388:2005.
- 6.2.2.2.15. Current collection dynamic behaviour (clause 4.2.8.2.9.6)  
 When a pantograph, holding an EC declaration of conformity or suitability for use as IC, is integrated in a rolling stock unit which is assessed according to the CR LOC & PAS TSI, dynamic tests shall be carried out in order to measure the mean contact force and standard deviation or the percentage of arcing, in accordance with EN 50317:2002 up to the design speed for the unit.  
  
 The tests, for each installed pantograph, shall be conducted in both directions of travel and shall include track sections with low contact wire height (defined as between 5,0 to 5,3 m) and track sections with high contact wire height (defined as between 5,5 to 5,75 m).  
  
 The tests shall be performed for a minimum of 3 speed increments up to and including the design speed of the unit. The interval between successive tests shall be no greater than 50 km/h.  
  
 The measured results shall be in accordance with the clause 4.2.8.2.9.6 for either mean contact force and standard deviation or percentage of arcing.
- 6.2.2.2.16. Arrangement of pantographs (clause 4.2.8.2.9.7)  
 The characteristics related to the dynamic behaviour of the current collection shall be verified as specified in clause 6.2.2.2.15 above.
- 6.2.2.2.17. Windscreen (clause 4.2.9.2)  
 The characteristics of the windscreen shall be verified as specified in EN 15152:2007 clauses 6.2.1 to 6.2.7.

**▼B**

## 6.2.2.2.18. Fire barriers (clause 4.2.10.5)

If the assessment of conformity to the requirements in clause 4.2.10.5 for FSPM is done with the help of computational fluid dynamics (CFD) simulations, these simulations shall be validated by 1:1 tests, conducted on a model representing the circumstances applicable to the unit which is subject to TSI assessment; the accuracy of the demonstration method shall be taken into account.

## 6.2.2.3. Project phases where assessment is required

It is detailed in Annex H of this TSI in which phase of the project an assessment shall be done:

- Design and development phase:
  - Design review and/or design examination,
  - Type test: test to verify the design, if and as defined in the Section 4.2.
- Production phase: routine test to verify the conformity of production.

The entity in charge of the assessment of the routine tests is determined according to the assessment module chosen.

The Annex H is structured according to the Section 4.2, which defines the requirements and their assessment applicable to the rolling stock subsystem; where relevant, a reference to a sub-clause of the clause 6.2.2.2 above is also given.

In particular, where a type test is identified in the Annex H, the Section 4.2 shall be considered for the conditions and requirements related to this test.

Where several EC verifications (e.g. against several TSIs addressing the same subsystem) require verification based on the same production assessment (module SD or SF), it is allowed to combine several SB module assessments with one production module assessment (SD or SF). In this case, ISVs shall be issued for the design and development phases according to module SB.

If module SB is used, the validity of the EC declaration of intermediate subsystem conformity shall be indicated in accordance with the provisions for phase B of clause 7.1.3 'Rules related to the EC verification', of this TSI.

6.2.3. *Innovative solutions*

If rolling stock includes an innovative solution (as defined in clause 4.1.1), the applicant shall state the deviations from the relevant provisions of the TSI, and submit them to the Commission for analysis.

In case the analysis results in a favourable opinion, the appropriate functional and interface specifications as well as the assessment methods which are necessary to be included in the TSI in order to allow this solution will be developed.

The appropriate functional and interface specifications and the assessment methods so produced shall then be incorporated in the TSI by the revision process.

By the notification of a decision of the Commission, taken in accordance with Article 29 of Directive 2008/57/EC, the innovative solution may be permitted to be used before being incorporated into the TSI by the revision process.

**▼ B**6.2.4. *Assessment of documentation requested for operation and maintenance*

According to Article 18 (3) of Directive 2008/57/EC, a notified body shall be responsible for compiling the technical file, containing the documentation requested for operation and maintenance.

The notified body shall verify only that the documentation requested for operation and maintenance, as defined in clause 4.2.12 of this TSI, is provided. The notified body is not required to verify the information contained in the documentation provided.

6.2.5. *Units requiring EC certificates against the HS RST TSI and against this TSI*

This clause covers the case of a unit type subject to assessment against this TSI, and:

- which has also to be assessed against the HS RST TSI, or
- which has already been granted an EC certificate of verification against the HS RST TSI.

The parameters which are covered in both TSIs, and are equally specified, are listed in the table below; these parameters do not need to be reassessed by the notified body appointed to perform the assessment according to this TSI; the assessment performed against the HS RST TSI is deemed to be recognised as valid for both TSIs.

The EC certificate of verification drawn up by the notified body to document the compliance of the unit type to this TSI may refer to the EC certificate of verification stating the compliance to the HS RST TSI for the following clauses of this TSI, provided that the condition stated below for the corresponding clause is met:

Element of the RST subsystem	Clause in the present TSI	Clause in the HS RST TSI	Condition for validity of the assessment against HS RST TSI
<b>Structure and mechanical parts</b>	<b>4.2.2</b>		
End coupling	4.2.2.2.3	4.2.2.2	—
Rescue coupling	4.2.2.2.4	4.2.2.2	—
Staff access for coupling and uncoupling	4.2.2.2.5	4.2.2.2	—
Strength of vehicle structure	4.2.2.4	4.2.2.3	—
Passive safety	4.2.2.5	4.2.2.3	—
Staff access doors	4.2.2.8	4.2.2.4.2.2	—
<b>Track interaction and gauging</b>	<b>4.2.3</b>		
Gauge — Kinematic gauge	4.2.3.1	4.2.3.1 4.2.3.9	—

**▼B**

Element of the RST subsystem	Clause in the present TSI	Clause in the HS RST TSI	Condition for validity of the assessment against HS RST TSI
Wheel load	4.2.3.2.2	4.2.3.2	—
Rolling stock parameters which influence CCS subsystem	4.2.3.3.1	4.2.3.2 4.2.3.3.1 4.2.3.4.9.1 4.2.3.4.9.3 4.2.3.10	—
Axle bearing condition monitoring	4.2.3.3.2	4.2.3.3.2	—
Running dynamic behaviour	4.2.3.4.2	4.2.3.4.1	Assessment has to include tests at operating speed on the CR network
Limit values for running safety	4.2.3.4.2.1	4.2.3.4.2	—
Track loading limit values	4.2.3.4.2.2	4.2.3.4.3	—
Equivalent conicity: Design values for new wheel profiles	4.2.3.4.3.1	4.2.3.4.6 4.2.3.4.7	Simulations have to be performed for the 3 additional rail profiles specified in the CR LOC & PAS TSI
Geometrical characteristics of wheels	4.2.3.5.2.2	4.2.3.4.9.2	—
<b>Braking</b>	<b>4.2.4</b>		
Functional requirements	4.2.4.2.1	4.2.4.3 4.2.4.6	—
Emergency braking	4.2.4.4.1	4.2.4.3	—
Service braking	4.2.4.4.2	4.2.4.3	—
Emergency braking performance	4.2.4.5.2	4.2.4.1	Assessment has to include tests at operating speed on the CR network
Service braking performance	4.2.4.5.3	4.2.4.4	Assessment has to include tests at operating speed on the CR network
Parking brake performance	4.2.4.5.5	4.2.4.6	—
Limit of wheel rail adhesion profile	4.2.4.6.1	4.2.4.2	—
Brake requirements for rescue purposes	4.2.4.10	4.2.4.3	—
<b>Passenger related items</b>	<b>4.2.5</b>		
Sanitary systems	4.2.5.1	4.2.2.5	—
Public address system: audible communication system	4.2.5.2	4.2.5.1	—
Passenger alarm: Functional requirements	4.2.5.3	4.2.5.3	—
Safety instructions to passengers — Signs	4.2.5.4	4.2.5.2	—
<b>Environmental conditions and aerodynamic effects</b>	<b>4.2.6</b>		

**▼B**

Element of the RST subsystem	Clause in the present TSI	Clause in the HS RST TSI	Condition for validity of the assessment against HS RST TSI
Slipstream effects on passengers on platform	4.2.6.2.1	4.2.6.2.2	—
Slipstream effects on workers at the track side	4.2.6.2.2	4.2.6.2.1	—
Head pressure pulse	4.2.6.2.3	4.2.6.2.3	—
<b>External lights and visible and audible warning device</b>	<b>4.2.7</b>		
External front and rear lights	4.2.7.1	4.2.7.4.1	—
Horn	4.2.7.2	4.2.7.4.2	—
<b>Traction and electrical equipment</b>	<b>4.2.8</b>		
Traction performance	4.2.8.1	4.2.8.1	—
Power supply	4.2.8.2.1 to 4.2.8.2.7	4.2.8.3	—
Requirements linked to pantograph	4.2.8.2.9	4.2.8.3.6 to 3.8	Assessment has to include tests at operating speed on the CR network
Electrical protection of the train	4.2.8.2.10	4.2.8.3.6.6- + open point	—
Protection against electrical hazards	4.2.8.4	4.2.7.3	—
<b>Driver's cab and driver-machine interface</b>	<b>4.2.9</b>		
Access and egress	4.2.9.1.2	4.2.2.6 4.2.7.1.2	—
External visibility	4.2.9.1.3	4.2.2.6	—
Interior layout	4.2.9.1.4	4.2.2.6	—
Driver's seat	4.2.9.1.5	4.2.2.6	—
Climate control and air quality	4.2.9.1.7	4.2.7.7	—
Windscreen	4.2.9.2	4.2.2.7	—
Storage facility for staff personal effects	4.2.9.5	4.2.2.8	—
<b>Fire safety and evacuation</b>	<b>4.2.10</b>		
General and categorisation	4.2.10.1	4.2.7.2	—
Material requirements	4.2.10.2	4.2.7.2.2	—
Specific measures for flammable liquids	4.2.10.3	4.2.7.2.5.2	—
Passenger evacuation	4.2.10.4	4.2.7.1.1	—
Fire barriers	4.2.10.5	4.2.7.2.3.3	—
<b>Servicing</b>	<b>4.2.11</b>		



**▼ B**

Element of the RST subsystem	Clause in the present TSI	Clause in the HS RST TSI	Condition for validity of the assessment against HS RST TSI
Train exterior cleaning	4.2.11.2	4.2.9.2	—
Toilet discharge system	4.2.11.3	4.2.9.3	—
Water refilling equipment	4.2.11.4	4.2.9.5	—
Interface for water refilling	4.2.11.5	4.2.9.5.2	—
<b>Documentation for operation and maintenance</b>	<b>4.2.12</b>		
Maintenance file	4.2.12.3	4.2.10.2	—
Operating documentation	4.2.12.4	4.2.1.1	—

6.2.6. *Assessment of units intended to be used in general operation*

Where a new, upgraded or renewed unit to be used in general operation is subject to assessment against this TSI (in accordance with clause 4.1.2), some of the TSI requirements require a reference train for their assessment. This is mentioned in the relevant provisions of Section 4. Similarly, some of the TSI requirements at train level are not able to be assessed at unit level; such cases are described for the relevant requirements in Section 4.2 of this TSI.

The area of use in terms of type of RST which, coupled with the unit to be assessed, ensures that the train is compliant with the TSI is not verified by the notified body.

After such a unit has received the authorisation to be placed in service, its use in a train formation (whether TSI compliant or not) shall be dealt with under the responsibility of the Railway Undertaking, according to the rules defined in clause 4.2.2.5 of the CR OPE TSI.

6.2.7. *Assessment of units intended to be used in pre-defined formation(s)*

Where a new, upgraded or renewed unit to be included in pre-defined formation(s) is subject to assessment (in accordance with chapter 4.1.2), the EC certificate of verification shall identify the formation(s) for which the assessment is valid: the type of RST coupled with the unit to be assessed, number of vehicles in the formation(s), arrangement of the vehicles in the formation(s) that will ensure that the train formation will be compliant with this TSI.

TSI requirements at train level shall be assessed with use of a reference train formation when and as specified in this TSI.

After such a unit has received the authorisation to be placed in service, it may be coupled with other units to constitute the formations mentioned in the EC certificate of verification.

6.2.8. *Particular case: Assessment of units intended to be included in an existing fixed formation*

6.2.8.1. **Context**

This particular case of assessment applies in case of replacement of a part of a fixed formation, which has already been placed in service.

**▼ B**

Two cases are described below, depending on the TSI status of the fixed formation.

The part of the fixed formation subject to the assessment is called 'unit' in the text below.

6.2.8.2. **Case of a TSI compliant fixed formation**

Where a new, upgraded or renewed unit to be included in an existing fixed formation is subject to assessment against this TSI, and a valid EC certificate of verification for the existing fixed formation is available, a TSI assessment only for the new unit is required in order to update the certificate of the existing fixed formation, which is considered as renewed (see also clause 7.1.2.2).

6.2.8.3. **Case of a non-TSI compliant fixed formation**

Where a new, upgraded or renewed unit to be included in an existing fixed formation is subject to assessment against this TSI, and a valid EC certificate of verification for the existing fixed formation is not available, the EC certificate of verification shall state that the assessment does not cover the TSI requirements applicable to the fixed formation, but only the assessed unit.

6.3. **Subsystem containing interoperability constituents not holding an EC declaration**

6.3.1. *Conditions*

During the transition period provided for in Article 6 of the Commission decision related to this TSI, a notified body is permitted to issue an EC certificate of verification for a subsystem, even if some of the interoperability constituents incorporated within the subsystem are not covered by the relevant EC declarations of conformity or suitability for use according to this TSI (non-certified ICs), if the following criteria are complied with:

- (a) the conformity of the subsystem has been checked against the requirements of Section 4 and in relation to Sections 6.2 to 7(except 'Specific cases') of this TSI by the notified body. Furthermore the conformity of the ICs to Sections 5 and 6.1 does not apply; and
- (b) the interoperability constituents, which are not covered by the relevant EC declaration of conformity or suitability for use, have been used in a subsystem already approved and put in service in at least one of the Member States before the date of application of this TSI.

EC declarations of conformity or suitability for use shall not be drawn up for the interoperability constituents assessed in this manner.

6.3.2. *Documentation*

The EC certificate of verification of the subsystem shall indicate clearly which interoperability constituents have been assessed by the notified body as part of the subsystem verification.

The EC declaration of verification of the subsystem shall indicate clearly:

- (a) which interoperability constituents have been assessed as part of the subsystem;

**▼B**

- (b) confirmation that the subsystem contains the interoperability constituents identical to those verified as part of the subsystem;
- (c) for those interoperability constituents, the reason(s) why the manufacturer did not provide an EC declaration of conformity or suitability for use before its incorporation into the subsystem, including the application of national rules notified under Article 17 of Directive 2008/57/EC.

6.3.3. *Maintenance of the subsystems certified according to clause 6.3.1*

During the transition period as well as after the transition period has ended, until the subsystem is upgraded, renewed (taking into account the MS's decision on application of TSIs), the interoperability constituents which do not hold an EC declaration of conformity or suitability for use and of the same type are permitted to be used as maintenance related replacements (spare parts) for the subsystem, under the responsibility of the ECM.

In any case the ECM must ensure that the components for maintenance related replacements are suitable for their applications, are used within their area of use, and enable interoperability to be achieved within the rail system while at the same time meeting the essential requirements. Such components must be traceable and certified in accordance with any national or international rule, or any code of practice widely acknowledged in the railway domain.

7. **IMPLEMENTATION**

7.1 **General rules for implementation**

7.1.1. *Application to newly built rolling stock*

7.1.1.1. **General**

This TSI is applicable to all units of rolling stock in its scope which are placed in service after the date of application of this TSI, except where the clause 7.1.1.2 'Transition period' or the clause 7.1.1.3 'Application to OTMs' below apply.

This TSI does not apply to units of existing rolling stock which are already in service on the network (or part of the network) of one Member State when this Decision applies, as long as they are not upgraded or renewed (see clause 7.1.2).

Any rolling stock which is produced according to a design developed after the date of application of this Decision shall be compliant with this TSI.

7.1.1.2. **Transition period**

7.1.1.2.1. **Introduction**

A significant number of projects or contracts, which started before the date of application of this Decision, will lead to the production of conventional rolling stock which does not fully comply with this TSI.

As it is provided in Article 2(2) of this Decision, for the rolling stock concerned by that projects or contracts, and in accordance with Article 5(3-f) of Directive 2008/57/EC, a transition period is

**▼B**

defined, during which the application of this TSI is not mandatory if that rolling stock is placed in service before the end date of the transition period. The end date of that transition period is stipulated in Article 2(2) of the Commission Decision related to this TSI.

This transition period applies to:

- projects at advanced stage of development, as described in the clause 7.1.1.2.2,
- contracts in course of performance, as described in the clause 7.1.1.2.3,
- rolling stock of an existing design, as described in clause 7.1.1.2.4.

During the transition period, if the applicant chooses not to apply this TSI, the vehicle may be authorised to be placed in service in accordance with Articles 24 (first authorisation) or 25 (additional authorisation) of Directive 2008/57/EC, instead of Articles 22 or 23.

Any rolling stock placed in service after the end date of the transition period described in this clause shall fully comply with this TSI without prejudice to Article 9 of Directive 2008/57/EC which allows Member States to request derogations under the conditions set out in that Article.

#### 7.1.1.2.2. Projects at advanced stage of development

This clause concerns a rolling stock which is developed and produced under a project at an advanced stage of development in accordance to Article 2(t) of the Directive. The project shall be at an advanced stage of development when this TSI is published in the *Official Journal of the European Union*.

The application of this TSI to rolling stock which falls under this clause is not mandatory during the transition period set out in clause 7.1.1.2.1, if that rolling stock is placed in service before the end of the transition period, as it is provided in Article 2(2) of this Decision.

#### 7.1.1.2.3. Contracts in course of performance

This clause concerns a rolling stock which is developed and produced under a contract which is signed before the publication of this TSI in the *Official Journal of the European Union*.

The applicant has to bring evidence of the date of signature of the original contract applicable. The date of any addenda in the form of changes to an original contract shall not be taken into account when defining the date of signature of the contract in question.

The application of this TSI to rolling stock which falls under this clause is not mandatory during the transition period set out in clause 7.1.1.2.1, if that rolling stock is placed in service before the end of the transition period, as it is provided in Article 2(2) of this Decision.

#### 7.1.1.2.4. Rolling stock of an existing design

This clause concerns rolling stock which is produced according to a design developed before the publication of the TSI in the *Official Journal of the European Union*, and which therefore has not been assessed according to this TSI.

The application of this TSI to rolling stock which falls under this clause is not mandatory during the transition period set out in clause 7.1.1.2.1, if that rolling stock is placed in service before the end of the transitional period, as it is provided in Article 2(2).

**▼B**

For the purpose of this TSI, a rolling stock can be qualified as 'built according to existing design' when one of the two following conditions is met:

- For ordering, or placing in service of rolling stock: the applicant can prove that the newly built rolling stock will be produced according to a documented design that has already been used to produce a rolling stock which has been authorised to be placed into service in a Member State before the date of publication of this TSI in the *Official Journal of the European Union*.
- For rolling stock of a type which is not produced under a contract, but on the manufacturer's initiative: the manufacturer or the applicant can prove that the project was in pre-production phase, or in series production at the date of publication of this TSI. In order to prove this, at least one prototype shall be in assembly phase with an existing identifiable body shell, and components already ordered from sub-suppliers shall represent 90 % of the total value of components.

The applicant shall demonstrate to the NSA that the conditions spelled out under the respective bullet point in this clause (depending on the situation at hand) are met.

For modifications to an existing design (not TSI compliant), the following rules apply during the transition period:

- In case of design modifications strictly limited to those necessary to ensure the technical compatibility of the rolling stock with fixed installations (corresponding to interfaces with infrastructure, energy, or control-command and signalling subsystems), the application of this TSI is not mandatory; the vehicle produced according to the 'modified' design may be authorised in accordance with Article 24 or 25 of Directive 2008/57/EC.
- In case of other design modifications, the present clause related to 'existing design' does not apply; therefore, as the design is considered as a new one, the application of this TSI is required.

#### 7.1.1.3. Application to OTMs

The application of this TSI to OTMs (as defined in Sections 2.2 and 2.3) is not mandatory.

The conformity assessment process as described in the Section 6.2.1 may be used by applicants on a voluntary basis in order to establish an EC declaration of verification; this EC declaration of verification shall be recognised as such by Member States.

In case the applicant chooses not to establish an EC declaration of verification, the OTMs may be authorised in accordance with Article 24 or 25 of Directive 2008/57/EC.

#### 7.1.1.4. Interface with implementation of other TSIs

As reminded in Section 2.1, other TSIs apply to the rolling stock subsystem; these other TSIs specify the implementation rules relevant for the requirements they cover.

**▼B**

In order to prevent misunderstanding between the implementation rules of these other TSIs and the implementation rules of the present CR LOC & PAS TSI, the following applies in case these other TSIs are referenced in the present TSI:

- Where an informative reference is made as a clarification for the reader of this CR LOC & PAS TSI, the implementation rules of the other TSI applies (e.g. when pointing at a provision of the PRM TSI, SRT TSI or the NOISE TSI as a reminder).
- Where a mandatory reference is made to avoid repeating the paragraph of another TSI (e.g. by extending a provision of the HS RST TSI or of the SRT TSI to this CR LOC & PAS TSI), the reference is a requirement of this CR LOC & PAS TSI and it is the implementation strategy of this CR LOC & PAS TSI that applies.

### 7.1.2. *Renewal and upgrade of existing rolling stock*

#### 7.1.2.1. *Introduction*

This clause provides information which relates to Article 20 of Directive 2008/57/EC.

#### 7.1.2.2. *Renewal*

The Member State shall use the following principles as a basis for determining the application of this TSI in case of renewal:

- A new assessment against the requirements of this TSI is only needed for the basic parameters in this TSI which have their performance influenced by the modification(s).
- For existing non-TSI compliant rolling stock, when during the renewal it is not economically feasible to fulfil the TSI requirement, the renewal could be accepted if it is evident that a basic parameter is improved in the direction of the TSI defined performance.
- The impact of national migration strategies resulting from the implementation of other TSIs.

For a project including elements not being TSI conform, the procedures for the assessment of conformity and EC verification to be applied should be agreed with the Member State.

For existing non-TSI compliant design of rolling stock, the replacement of a whole unit or (a) vehicle(s) within a unit (e.g. a replacement after a severe damage; see also clause 6.2.8) does not require a conformity assessment against this TSI, as long as the unit or the vehicle(s) are identical to the ones they replace. Such units must be traceable and certified in accordance with any national or international rule, or any code of practice widely acknowledged in the railway domain.

**▼B**

For the replacement of TSI conform units or vehicles, a conformity assessment against this TSI is required.

## 7.1.2.3. Upgrade

The Member State shall use the following principles as a basis for determining the application of this TSI in case of upgrade:

- Parts and basic parameters of the subsystem that have not been affected by the upgrading works are exempt from conformity assessment against the provisions in this TSI.
- A new assessment against the requirements of this TSI is only needed for the basic parameters in this TSI which have their performance influenced by the modification(s).
- When during the upgrade it is not economically feasible to fulfil the TSI requirement, the upgrade could be accepted if it is evident that a basic parameter is improved in the direction of the TSI defined performance.
- Guidance to the Member State for those modifications that are deemed to be upgrades is given in the application guide.
- The impact of national migration strategies resulting from the implementation of other TSIs.

For a project including elements not being TSI conform, the procedures for the assessment of conformity and EC verification to be applied should be agreed with the Member State.

7.1.3. *Rules related to the type or design examination certificates*

## 7.1.3.1. Rolling stock subsystem

This clause concerns a rolling stock type (unit type in the context of this TSI), as defined in Article 2(w) of Directive 2008/57/EC, which is subject to an EC type or design verification procedure in accordance with the clause 6.2.2.1 of this TSI.

The TSI assessment basis for a 'type or design examination' is defined in columns 2 and 3 (design and development phase) of Annex H of this TSI.

**Phase A**

Phase A starts once a notified body, which is responsible for EC verification, is appointed by the applicant and ends when the EC type examination certificate is issued.

The TSI assessment basis for a type is defined for a phase A period, with a duration of maximum seven years. During the phase A period the assessment basis for EC verification to be used by the notified body will not change.

When a revised version of this TSI comes into force during the phase A period, it is permissible but not mandatory to use the revised version.

**Phase B**

The phase B period defines the period of validity of the type examination certificate once it is issued by the notified body. During this time, units may be EC certified on the basis of conformity to type.

**▼B**

The type examination certificate of EC verification for the subsystem is valid for a seven year phase B period after its issue date, even if a revision of this TSI comes into force. During this time, new rolling stock of the same type is permitted to be placed in service on the basis of an EC declaration of verification referring to the type certificate of verification.

**Modifications to a type or design already bearing an EC certificate of verification**

For modifications to a rolling stock type already bearing a type or design examination certificate of verification, the following rules apply:

- The changes are permitted to be dealt with by only reassessing those modifications which influence the basic parameters of the latest revision of this TSI in force at that time.
- In order to establish the certificate of EC verification, the notified body is permitted to refer to:
  - the original type or design examination certificate for parts of the design that are unchanged, as far as it is still valid (during 7 years phase B period),
  - additional type or design examination certificate (amending the original certificate) for modified parts of the design which influence the basic parameters of the latest revision of this TSI in force at that time.

7.1.3.2. **Interoperability constituents**

This clause concerns an interoperability constituent which is subject to type examination (module SB) or to suitability for use (module CV).

The type or design examination or suitability for use certificate is valid for a five year period. During this time, new constituents of the same type are permitted to be placed into service without a new type assessment. Before the end of the five-year period, the constituent shall be assessed according to the latest revision of this TSI in force at that time, for those requirements that have changed or are new in comparison to the certification basis.

7.2. **Compatibility with other subsystems**

The conventional rail ‘Locomotives and passenger trains’ TSI has been developed with consideration of other subsystems being compliant to their respective conventional rail TSIs. Accordingly, interfaces with the conventional rail fixed installations infrastructure, energy and control-command subsystems are addressed for subsystems compliant with the CR INF, ENE, CCS TSIs.

Following this, the implementation methods and phases concerning rolling stock depend on the progress of implementation of the conventional rail infrastructure, energy, control-command and signalling TSIs.

Furthermore, TSIs covering the conventional rail fixed installations allow for variants.



**▼B**

For rolling stock, these variants will be part of the technical characteristics to be recorded in the 'European register of authorised types of vehicles', according to Article 34 of Directive 2008/57/EC.

For infrastructure, they will be part of the main features recorded in the 'Register of infrastructure', according to Article 35 of Directive 2008/57/EC.

7.3. **Specific cases**

7.3.1. *General*

The specific cases, as listed in the following clause, describe special provisions that are needed and authorised on particular networks of each Member State.

These specific cases are classified as:

'P' cases: 'permanent' cases.

'T' cases: 'temporary' cases, where it is recommended that the target system is reached by 2020 (an objective set in Decision No 1692/96/EC, as amended by Decision 884/2004/EC of the European Parliament and Council <sup>(1)</sup>).

Any specific case applicable to the rolling stock in the scope of this TSI shall be addressed in this TSI.

Certain specific cases are in interface to other TSIs. Where a clause in this TSI refers to another TSI to which a specific case is applicable, or where a specific case is applicable to the rolling stock as a consequence of a specific case declared in another TSI, these are re-stated in this TSI.

Moreover, some specific cases do not prevent the access to the national network to TSI compliant rolling stock. In that case, it is explicitly stated in the concerned section of the clause 7.3.2 below.

7.3.2. *List of specific cases*

7.3.2.1. **General specific cases**

**Specific case Greece**

('P') For rolling stock intended to run on the 1 000 mm Peloponnese networks, national rules apply.

**Specific case Estonia, Latvia, Lithuania, Poland and Slovakia for 1 520 mm networks**

('P') The application of the TSI to rolling stock intended to be used on 1 520 mm networks is an open point.

**Bilateral traffic with 3rd country 1 520 mm network: Specific case Finland**

('P') The application of national technical rules instead of the requirements in this TSI is allowed for third countries' rolling stock to be used on the Finnish 1 524 network in traffic between Finland and 3rd countries 1 520 network.

**Specific case Estonia, Latvia, Lithuania, Poland and Slovakia**

('P') The application of national technical rules instead of the requirements in this TSI is allowed for rolling stock intended to be used on the 1 520 network(s) in traffic between Member States and 3rd countries.

<sup>(1)</sup> OJ L 167, 30.4.2004, p. 1.

**▼B**7.3.2.2. Mechanical interfaces — End coupling  
(4.2.2.2.3)**Specific case Finland**

(‘P’) If rolling Stock intended for traffic in Finland is equipped with buffers, the distance between buffer centrelines shall be 1 830 mm (+/- 10 mm).

Other requirements in clause 4.2.2.2.3 ‘End coupling’ apply.

**Specific case Spain**

(‘T’) If rolling stock intended for traffic in Spain on the 1 668 mm track gauge network is equipped with buffers and screw coupling, the distance between buffer centrelines shall be 1 850 mm (+/- 10 mm).

Other requirements in clause 4.2.2.2.3 ‘End coupling’ apply.

**Specific case Republic of Ireland and UK for Northern Ireland**

(‘P’) If rolling stock intended for traffic in Ireland is equipped with buffers and screw coupling, the distance between the buffer centrelines shall be 1 905 mm (+/- 10 mm), and the buffer and draw gear centre heights above the rail must be between 1 067 mm minimum and 1 092 mm maximum in an unloaded condition.

## 7.3.2.3. Gauging (4.2.3.1)

**Specific case Finland**

(‘P’) Units designed to operate on the Finnish 1 524 networks, the unit shall remain within the gauge FIN1 under the conditions as defined in EN 15273-2:2009.

*Note:* See also the specific case 7.3.2.8 ‘Wheelsets’ for track gauge.

**Specific case Portugal**

(‘P’) Units designed to operate on the Portuguese network shall remain within the kinematic gauges PTb, PTb+, or PTc, as defined in annex I of EN 15273-2:2009.

*Note:* See also the specific case 7.3.2.8 ‘Wheelsets’ for track gauge.

**Specific case Sweden**

(‘P’) Units designed to operate on the Swedish network shall remain within the gauges SEA or SEC in accordance with EN15273-2:2009.

This specific case does not prevent the access of TSI compliant rolling stock to the national network.

**Specific case UK for Great Britain**

(‘P’) Units designed to operate on the GB network shall remain within the kinematic gauge defined in the clause CR INF TSI 7.6.12.2.

With respect to kinematic gauge, the assessment of compliance shall be in accordance with the methodologies set out in notified national technical rules.

For upgraded and renewed lines, pantographs of vehicles used in Great Britain shall remain within the gauge defined in notified national technical rules.

**▼B****Specific case the Netherlands**

(‘P’) Units designed to operate on the Dutch network shall remain within the kinematic gauges NL1 or NL2 in accordance with EN15273-2:2009 (annex M).

This specific case does not prevent the access of TSI compliant rolling stock to the national network.

*Note:* The compatibility between the infrastructure and the NL1 and NL2 gauges for rolling stock must be checked since not all lines are compliant to both gauges.

**Specific case Spain**

(‘P’) Units designed to operate on the Spanish 1 668 mm network shall remain within the GHE16 reference contour and associated rules as defined in national rules notified for this purpose.

*Note:* See also the specific case 7.3.2.8 ‘Wheelsets’ for track gauge.

**Specific case Republic of Ireland and UK for Northern Ireland**

(‘T’) The kinematic gauge of rolling stock is an open point.

## 7.3.2.4. Axle bearing condition monitoring (4.2.3.3.2)

**Specific case Finland**

(‘P’) For rolling stock intended to be used on Finnish network (1 524 mm track gauge) which depends on track side equipment for axle bearing condition monitoring, the target areas on the underside of an axle box that shall remain unobstructed to permit observation by a trackside HABD shall use dimensions as defined in EN 15437-1:2009, and replace the values by the following:

System based on trackside equipment:

The dimensions in clauses 5.1 and 5.2 of EN 15437-1:2009 are replaced respectively by the following dimensions. There are two different target areas (I and II) including their prohibitive and measuring zones defined:

- Dimensions for the target area I:
  - $W_{TA}$ , greater than or equal to 50 mm;
  - $L_{TA}$ , greater than or equal to 200 mm.
  - $Y_{TA}$  shall be 1 045 mm to 1 115 mm;
  - $W_{PZ}$ , greater than or equal to 140 mm;
  - $L_{PZ}$ , greater than or equal to 500 mm;
  - $Y_{PZ}$  shall be 1 080 mm  $\pm$  5 mm.
- Dimensions for the target area II:
  - $W_{TA}$ , greater than or equal to 14 mm;
  - $L_{TA}$ , greater than or equal to 200 mm;
  - $Y_{TA}$  shall be 892 mm to 896 mm;
  - $W_{PZ}$ , greater than or equal to 28 mm;
  - $L_{PZ}$ , greater than or equal to 500 mm;
  - $Y_{PZ}$  shall be 894 mm  $\pm$  2 mm.

**▼B****Specific case Spain**

(‘P’) For rolling stock intended to be used on the Spanish 1 668 mm track gauge network and which depends on track side equipment for axle bearing condition monitoring, the zone visible to the trackside equipment on rolling stock shall be the area as defined in EN 15437-1:2010 clauses 5.1 and 5.2 considering the following values instead of the stated ones:

- $YTA = 1\,176 \pm 10$  mm (lateral position of the centre of the target area relative to the centre line of the vehicle)
- $WTA \geq 55$  mm (lateral width of the target area)
- $LTA \geq 100$  mm (longitudinal length of the target area)
- $YPZ = 1\,176 \pm 10$  mm (lateral position of the centre of the prohibitive zone relative to the centre line of the vehicle)
- $WPZ \geq 110$  mm (lateral width of the prohibitive zone)
- $LPZ \geq 500$  mm (longitudinal length of the prohibitive zone)

**Specific case Portugal**

(‘P’) For rolling stock intended to be used on Portuguese network (1 668 mm track gauge) and which depends on track side equipment for axle bearing condition monitoring, the target area that shall remain unobstructed to permit observation by a trackside HABD and its position related to centre line vehicle shall be the following:

- $YTA = 1\,000$  mm (lateral position of the centre of the target area relative to the centre line of the vehicle)
- $WTA \geq 65$  mm (lateral width of the target area)
- $LTA \geq 100$  mm (longitudinal length of the target area)
- $YPZ = 1\,000$  mm (lateral position of the centre of the prohibitive zone relative to the centre line of the vehicle)
- $WPZ \geq 115$  mm (lateral width of the prohibitive zone)
- $LPZ \geq 500$  mm (longitudinal length of the prohibitive zone)

**Specific case Republic of Ireland and UK for Northern Ireland**

(‘P’) For rolling stock intended to be used on the Irish network and which depends on track side equipment for axle bearing condition monitoring, the target areas on the underside of an axle box that shall remain unobstructed are defined in national rules.

**Specific case Sweden**

(‘T’) This specific case is applicable to all units which are not fitted with onboard axle bearing condition monitoring equipment and are intended for operation on lines with non-upgraded axle bearing detectors. These lines are indicated in the network statement as being non-TSI compliant in this respect.

Lateral dimensions for axle bearing condition monitoring:

The zone visible to trackside equipment underside an axle box/journal shall be free to facilitate vertical monitoring:

- the lateral interval 842 to 882 mm relative to the centre of a pair of wheels,

**▼B**

- a minimum unbroken width of 40 mm within a minimum lateral distance relative to the centre of a pair of wheels of 865 mm and a maximum lateral distance relative to the centre of a pair of wheels of 945 mm.

Prohibitive area:

Within a longitudinal length of 500 mm, centrally situated to the centre line of the wheel axle, no part or component with a higher temperature than the axle box/journal shall be placed nearer than 10 mm to the lateral intervals.

#### 7.3.2.5. Rolling stock dynamic behaviour (4.2.3.4)

##### **Specific case Republic of Ireland and UK for Northern Ireland**

(‘T’) Due to alternative limit values for track twist and other relevant track quality related criteria on the existing network, a number of limit values and concepts contained within the Section 4.2.3.4 and its subsections and contained in EN14363:2005 as well as other standards referred to must be adapted in order to apply them on rolling stock to operate in the Republic of Ireland and in Northern Ireland.

This adaptation must fulfil IE-CME technical standard 302 or the applicable technical rule in the UK territory of Northern Ireland.

This applies to: 4.2.3.4.1 Safety against derailment running on twisted track, 4.2.3.4.2 Running dynamic behaviour, 4.2.3.4.2.1 Limit values for running safety, 4.2.3.4.2.2 Track loading limit values, 4.2.3.4.3 Equivalent conicity, 4.2.3.4.3.1 Design values for new wheel profiles, 4.2.3.4.3.2 In-service values of wheelset equivalent conicity.

Otherwise all other principles contained in the section and in EN14363 and other standards referred to shall follow the approach defined in this TSI.

##### **Specific case UK for Great Britain**

(‘P’) The limitations to the use of Method 3 set out in EN14363:2005 clause 4.1.3.4.1 are not applicable for rolling stock that is intended for national use on the UK mainline network only.

This specific case does not prevent the access to the national network to TSI compliant rolling stock.

#### 7.3.2.6. Track loading limit values (4.2.3.4.2.2)

##### **Specific case Spain**

(‘P’) For Rolling Stock intended to be used on 1 668 mm track gauge, the quasi-static guiding force  $Y_{qst}$  limit value shall be evaluated for curve radii  $250 \leq R < 400$  m.

**▼B**

The limit value shall be:  $(Y_{qst})_{lim} = (33 + 11\,550/R_m)$  kN.

7.3.2.7. Design values for new wheel profiles  
(4.2.3.4.3.1)

**Specific case Finland**

(‘P’) Wheels of trains designed for running on lines of the Finnish network shall be compatible with the track gauge of 1 524 mm.

Table 2

**Equivalent conicity design limit values**

Maximum vehicle operating speed (km/h)	Equivalent conicity limit values	Test conditions (see table 3)
≤ 60	N/A	N/A
> 60 and ≤ 190	0,30	All
> 190	Values specified in the HS RST TSI apply	Conditions specified in the HS RST TSI apply

Table 3

**Track test conditions for equivalent conicity representative of the Finnish TEN network**

Test condition number	Rail head profile	Rail inclination	Track gauge
1	Rail section 60 E1 defined in EN 13674-1:2003	1 in 40	1 524 mm
2	Rail section 60 E1 defined in EN 13674-1:2003	1 in 40	1 526 mm
3	Rail section 54 E1 defined in EN 13674-1:2003	1 in 40	1 524 mm
4	Rail section 54 E1 defined in EN 13674-1:2003	1 in 40	1 526 mm

The requirements of this clause are deemed to have been met by wheelsets having unworn S1002 or GV 1/40 profiles, as defined in EN13715:2006, with spacing of active faces between 1 505 mm and 1 511 mm.

**Specific case Portugal**

(‘P’) For Portugal, the track gauge of 1 668 mm shall be considered with a rail inclination of 1 to 20 for rail section 54E1 and 60E1.

**Specific case Spain**

(‘P’) For Rolling Stock intended to be used on 1 668 mm track gauge, equivalent conicity limits set in the table 2 shall not be exceeded when the designed wheelset is modelled passing over the representative sample of track test conditions as specified in table 3 below.



Table 2

## Equivalent concity design limit values

Maximum vehicle operating speed (km/h)	Equivalent concity limit values	Test conditions (see table 3)
≤ 60	N/A	N/A
> 60 and ≤ 190	0,30	All
> 190	Values specified in the HS RST TSI apply	Conditions specified in the HS RST TSI apply

Table 3

## Track test conditions for equivalent concity

Test condition number	Rail head profile	Rail inclination	Track gauge
1	Rail section 60 E 1 defined in EN 13674-1:2003	1 in 20	1 668 mm
2	Rail section 60 E 1 defined in EN 13674-1:2003	1 in 20	1 670 mm
3	Rail section 54 E1 defined in EN 13674-1:2003	1 in 20	1 668 mm
4	Rail section 54 E1 defined in EN 13674-1:2003	1 in 20	1 670 mm

The requirements of this clause are deemed to have been met by wheelsets having unworn S1002 or GV 1/40 profiles, as defined in prEN13715:2006 with spacing of active faces between 1 653 mm and 1 659 mm.

## 7.3.2.8. Wheelsets (4.2.3.5.2)

**Specific case Finland**

(‘P’) Wheelsets of trains designed for running on lines of the Finnish network shall be compatible with the track gauge of 1 524 mm.

The dimensions for wheelsets and wheels related to 1 524 mm track gauges are given in the following table:

Designation	Wheel diameter D (mm)	Nominal value (mm)	Minimum value (mm)	Maximum value (mm)
Requirements linked to subsystem				
Front-to-front dimension (SR) (Distance between flange contact faces) SR = AR+Sd (left wheel) + Sd (right wheel)	D > 725	1 510	1 487	1 514
	725 > D ≥ 400	—	1 506	1 509

**▼ B**

Designation	Wheel diameter D (mm)	Nominal value (mm)	Minimum value (mm)	Maximum value (mm)
Back to back distance (AR)	D > 725	1 445 +/- 1	1 442	1 448
	725 > D ≥ 400	1 445 +/- 1	1 444	1 446

## Requirements linked to interoperability constituent wheel

Designation	Wheel diameter D (mm)	Nominal value (mm)	Minimum value (mm)	Maximum value (mm)
Width of the rim (BR+Burr)	D ≥ 400	135 +/- 1	134	136
		140 +/- 1 <sup>(a)</sup>	139 <sup>(a)</sup>	141 <sup>(a)</sup>
Thickness of the flange (Sd)	D > 840	32,5	22	33
	840 > D ≥ 760	32,5	25	33
	760 > D ≥ 400	32,5	27,5	33
Height of the flange (Sh)	D > 760	28	27,5	36
	760 > D ≥ 630	30	29,5	36
	630 > D ≥ 400	32	31,5	36
Face of flange (qR)	≥ 400	—	6,5	—

<sup>(a)</sup> Allowed optionally for traction units.

(‘P’) For rolling stock to be used in traffic between Finnish 1 524 network and a third country 1 520 network it is allowed to use special wheelsets designed to accommodate the differences in track gauges.

**Specific case Portugal**

(‘P’) Mechanical and geometrical characteristics of wheelsets:

For the nominal track gauge (1 668 mm), the specifics values for Ar and Sr of Portuguese rail network are:

- Ar = 1 593 0/-3 (mm) - new wheelset
- Ar = 1 593 +3/-3 (mm) - maximum in service
- $1\,646 \leq Sr \leq 1\,661$  (mm)

Mechanical and geometrical characteristics of wheels:

The limit values for Sd and Sh of this specific case are:

- For D ≥ 800 mm  $22 \leq Sd \leq 33$  (mm)
- For D < 800 mm  $27,5 \leq Sd \leq 33$  (mm)
- Sh ≤ 36 (mm)

**Specific case Spain**

(‘P’) The geometrical dimensions of the wheelsets SR and AR shall be compliant with limit values specified below. These limit values shall be taken as design values (new wheelset) and as in-service limit values (to be used for maintenance purposes).



**▼B**

	Wheel diameter (mm)	Minimum (mm)	Maximum (mm)
S <sub>R</sub>	840 ≤ D ≤ 1 250	1 643	1 659
	330 ≤ D < 840	1 648	1 659
A <sub>R</sub>	840 ≤ D ≤ 1 250	1 590	1 596
	330 ≤ D < 840	1 592	1 596

(‘T’) Thickness of the flange (S<sub>d</sub>) shall be 25 mm minimum for wheel diameters > 840 mm and 27,5 mm for wheel diameters between 330 mm and 840 mm for vehicles intended to circulate on 1 668 mm track gauge.

**Specific case Republic of Ireland and UK for Northern Ireland**

(‘P’) In relation to clause 4.2.3.5 including its subsections, all geometric dimensions of wheel sets must fulfil IE-CME technical standard 301 or the applicable technical rule in the UK territory of Northern Ireland.

This applies to the clauses: 4.2.3.5.2 Wheelsets, 4.2.3.5.2.1 Mechanical and geometrical characteristics of wheelsets, 4.2.3.5.2.2 Mechanical and geometrical characteristics of wheels.

7.3.2.9. Geometrical characteristics of wheels (4.2.3.5.2.2)

**Specific case UK for Great Britain**

(‘P’) For rolling stock for national use only, the minimum value of the width of the rim (BR + Burr) is permitted to be equal to 127 mm (instead of 133 mm).

This specific case does not prevent the access to the national network to TSI compliant rolling stock.

7.3.2.10. Slipstream effects on passengers on platforms (4.2.6.2.1)

**Specific case UK for Great Britain**

(‘P’) It is permissible for rolling stock operating on the GB network to be tested in accordance with the following requirement.

Rolling stock running in the open air at a maximum operating speed  $v_{tr} > 160$  km/h (100 mile/h), shall not cause the air speed to exceed value  $u_{2\sigma} = 11,5$  m/s at a height of 1,2 m above the platform and at a distance of 3,0 m from the track centre, during the passage of rolling stock.

Conformity shall be assessed on the basis of full-scale tests under conditions specified in EN 14067-4:2005/A1:2009 clause 7.5.2. The measurements shall be performed on a platform of a height above top of rail of 915 mm or lower.

This specific case does not prevent the access of TSI compliant rolling stock to the national network.

7.3.2.11. Head pressure pulse (4.2.6.2.3)

**Specific case UK for Great Britain**

(‘P’) Instead of the requirement set out in clause 4.2.6.2.3, the following applies for rolling stock operating on the GB network:

**▼B**

Rolling stock running with a speed higher than 160 km/h in the open air shall not cause the maximum peak-to-peak pressure of changes to exceed a value  $\Delta p_{2\sigma}$  of 665 Pa as measured over the range of height between 1,5 m and 3,3 m above the top of rail, and at a distance of 2,5 m from the track centre, during the passage of the head.

7.3.2.12. Warning horn sound pressure levels (4.2.7.2.2)

**Specific case UK for Great Britain**

(‘P’) Rolling stock for national use only, may be compliant with the horn sound pressure levels as stipulated in the national technical rules notified for this purpose in the UK.

Trains intended for international use shall be compliant with the horn sound pressure levels as stipulated in this TSI.

This specific case does not prevent the access of TSI compliant rolling stock to the national network.

7.3.2.13. Power supply — General (4.2.8.2.1)

**Specific case UK for Great Britain**

(‘P’) It is permissible to continue to procure rolling stock to operate on, and be compatible with, lines equipped with the electrification system operating at 600/750 V DC and utilising ground level conductor rails in a three and/or four rail configuration. Notified national technical rules shall apply.

7.3.2.14. Operation within range of voltages and frequencies (4.2.8.2.2)

**Specific case France**

(‘T’) Electric units to be operated on the DC 1,5 kV system depicted in the clause 7.5.2.2.1 of the CR energy TSI shall be able to operate within the range of voltage defined in that clause 7.5.2.2.1 of the CR energy TSI.

7.3.2.15. Working range in height of pantograph (4.2.8.2.9.1)

**Specific case Finland**

(‘P’) The installation of a pantograph on a rolling stock shall allow current collection from contact wires at heights between 5 600 – 6 600 mm above rail level for tracks designed according to the gauge FIN1.

**Specific case UK for Great Britain**

(‘P’) All rolling stock required to operate on the UK AC 25kV 50Hz system that has not been upgraded in accordance with the CR ENE TSI, the following requirement shall apply:

Pantographs shall have a working range of 2 100 mm. When mounted on an electric unit, the pantograph shall operate between 4 140 mm (the lower operating position, ref. EN50206-1, 3.2.13) and 6 240 mm (the upper operating position, ref. EN50206-1, 3.2.13) above rail level.

**▼B**

In exceptional topographical circumstances where electrical clearances are limited by physical restrictions, and a reduced maximum rolling-stock (static) height of 3 775 mm applies, pantographs on these vehicles shall have a working range of 2 315 mm. When mounted on an electric unit, the pantograph shall operate between 3 925 mm (the lower operating position, ref. EN50206-1, 3.2.13) and 6 240 mm (the upper operating position, ref. EN50206-1, 3.2.13) above rail level.

**Specific case the Netherlands**

(‘T’) For unrestricted access to the 1 500 V DC Dutch network, the maximum height of pantograph shall be limited to 5 860 mm.

## 7.3.2.16. Pantograph head geometry (4.2.8.2.9.2)

**Specific case UK for Great Britain**

(‘T’) For rolling stock required to operate on the UK AC 25kV 50Hz system that has not been upgraded in accordance with the CR ENE TSI, the following requirement shall apply:

In order to maintain compatibility with the existing infrastructure the profile of the pantograph head shall be as depicted in EN 50367:2006, Annex B.7.

In order to maintain compatibility with requirements for running through phase or system separation sections, pantograph heads shall have a maximum along track width of 250 mm, unless permitted by arrangements set out in the Infrastructure Register.

**Specific case Portugal**

(‘P’) For rolling stock required to operate on lines where the energy subsystem not been upgraded in accordance with the CR ENE TSI, the following requirement shall apply to pantograph heads lengths:

— 1 450 mm for 25 kV AC system, and

— 2 180 mm for 1,5 kV DC system.

**Specific case Italy**

(‘T’) On trains traversing existing TEN lines with catenary systems only compatible with pantograph heads geometry of length 1 450 mm, pantographs with heads geometry of length 1 450 mm shall be installed.

On trains which are intended for national use only and traversing both lines compatible with pantograph heads geometry of lengths 1 600 mm and 1 450 mm, it is allowed to install only pantographs with head geometry of length 1 450 mm.

(‘P’) Trains intended to be operated in Italy and Switzerland, or on other lines outside the TEN with catenary systems only compatible with 1 450 mm pantographs, shall be provided with 1 450 mm wide pantographs heads. On these trains it is allowed to install only pantographs with head geometry of length 1 450 mm as long as they only traverse lines compatible with pantograph heads geometry of length 1 450 mm.

**▼B**

The profile of this pantograph head shall be as depicted in EN 50367:2006, Annex B.2.

**Specific case France**

(‘P’) Trains intended to be operated in France and Switzerland, or on other lines outside the TEN with catenary systems only compatible with 1 450 mm pantographs, shall be provided with 1 450 mm wide pantographs heads. On these trains it is allowed to install only pantographs with head geometry of length 1 450 mm as long as they only traverse lines compatible with pantograph heads geometry of length 1 450 mm.

The profile of this pantograph head shall be as depicted in EN 50367:2006, Annex B.2.

**Specific case Sweden**

(‘P’) This specific case is applicable for units operated on lines with non-upgraded catenary system. These lines are indicated in the network statement as being non-TSI compliant in this aspect.

The gauge of the pantograph shall fulfil requirements according Swedish technical specifications JVS-FS 2006:1 and BVS 543.330.

**Specific case Slovenia**

(‘P’) On electric units intended to operate:

- on lines with catenary system only compatible with pantographs head geometry of length 1 450 mm, pantographs with head geometry of length 1 450 mm shall be installed, and it is allowed to install only pantographs with head geometry 1 450 mm,
- on lines with catenary system compatible with pantographs head geometry of length 1 450 mm and 1 600 mm, it is allowed to install only pantographs with head geometry 1 450 mm as long as they only traverse lines compatible with pantograph heads geometry of length 1 450 mm.

The profile of this pantograph head shall be as depicted in EN 50367:2006, Annex B.2.

7.3.2.17. **Pantograph contact force and dynamic behaviour (4.2.8.2.9.6)**

**Specific case UK for Great Britain**

(‘P’) Rolling stock and pantographs fitted on rolling stock shall be designed and tested to exert a mean contact force  $F_m$  on the contact wire in a range as specified in clause 4.2.16 of the CR energy TSI, in order to ensure current collection quality without undue arcing and to limit wear and hazards to contact strips. Adjustment of the contact force is made when dynamic tests are performed.

The conformity assessment principles of the current quality collection are described in clause 4.2.16 of the CR energy TSI.

**▼B**

For the purposes of clauses 4.2.8.2.9.6, 6.1.2.2.6 and 6.2.2.2.15, on trains intended to be certified for use in Great Britain and elsewhere, the tests shall additionally be conducted at a wire height between 4 700 mm and 4 900 mm.

For the purposes of clauses 4.2.8.2.9.6, 6.1.2.2.6 and 6.2.2.2.15, on trains intended to be certified only for use in Great Britain, it is permissible to verify compliance only within the range of 4 700 mm to 4 900 mm contact wire height.

**Specific case Sweden**

(‘P’) This specific case is applicable for units operated on lines with non-upgraded catenary system. These lines are indicated in the network statement as being non-TSI compliant in this aspect.

The mean contact force of the pantograph shall fulfil requirements according Swedish technical specifications JVS-FS 2006:1 and BVS 543.330.

**Specific case France**

(‘P’) For the purposes of clauses 4.2.8.2.9.6, 6.1.2.2.6 and 6.2.2.2.15, on trains intended to be operated on the 1,5 kV DC system, the mean contact force shall be as specified in the clause 7.5.2.2.2 of the CR energy TSI.

## 7.3.2.18. Front visibility (4.2.9.1.3.1)

**Specific case UK for Great Britain**

(‘P’) Instead of the requirements set out in 4.2.9.1.3.1, for rolling stock intended for operation in the UK, the following specific case shall be complied with.

The driver’s cab shall be designed to allow the driver at his seated driving position a clear and unobstructed line of sight in order to distinguish fixed signals in accordance with the national technical rule, GM/RT2161 ‘Requirements for driving cabs of railway vehicles’.

## 7.3.2.19. Driver’s desk — Ergonomics (4.2.9.1.6)

**Specific case UK for Great Britain**

(‘P’) In case the requirements in clause 4.2.9.1.6, last paragraph, related to the direction of movement of the lever for traction and/or braking is incompatible with the safety management system of the railway undertaking operating in Great Britain, it is allowed to inverse the direction of movement for braking and traction respectively.

## 7.3.2.20. Material requirements (4.2.10.2)

**Specific case Spain**

(‘T’) For rolling stock only intended for national use on the Spanish network and until EN 45545 is published, Spanish standard for fire safety DT-PCI/5A may be applied as an alternative to the material requirements in clause 4.2.10.2 of this TSI.

**▼B**

This specific case does not prevent the access to the national network to TSI compliant rolling stock.

7.3.2.21. Interfaces for water refilling (4.2.11.5) and toilet discharge (4.2.11.3)

**Specific case Republic of Ireland and UK for Northern Ireland**

(‘P’) Alternatively to, or in addition to what is specified in clause 4.2.11.6 of this TSI, it is allowed to install a nozzle type water refilling interface. This nozzle type refilling interface must fulfil the requirements of IE-CME technical standard 307, Appendix 1 or the applicable technical rule in the UK territory of Northern Ireland.

This specific case does not prevent the access of TSI compliant rolling stock to the national network.

**Specific case Finland**

(‘P’) Alternatively to, or in addition to what is specified in clause 4.2.11.5, it is allowed to install water filling connections compatible with the track side installations on the Finnish network in accordance with figure AIII.

This specific case does not prevent the access of TSI compliant rolling stock to the national network.

*Figure AIII*

**The water filling adaptor**

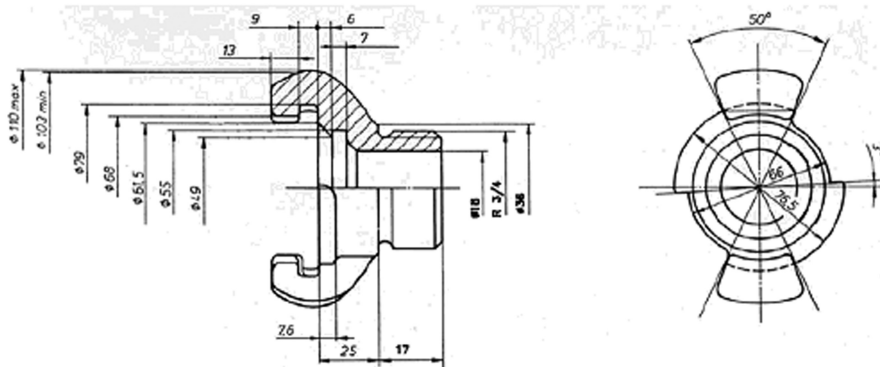

Type: Connector C for firefighting NCU1

Material: Brass or aluminium

Specific definition in the standard SFS 3802 (sealing defined by each connector manufacturer)

(‘P’) Alternatively to, or in addition to what is specified in clause 4.2.11.3, it is allowed to install connections for toilet discharge and for rinsing of the sanitary discharge tanks, compatible with the track side installations on the Finnish network in accordance with figures AII and AI2.

This specific case does not prevent the access of TSI compliant rolling stock to the national network.

▼ **B**

Figure A11

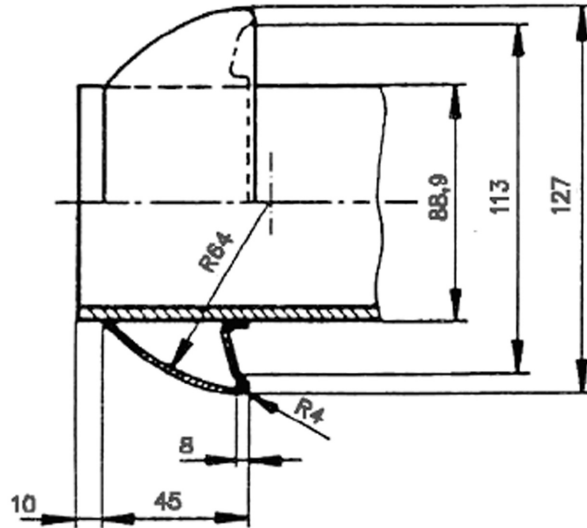
**Emptying connections for toilet tank**

Quick connector SFS 4428, connector part A, size DN80

Material: Acid-proof stainless steel

Sealing on the counter-connector's side

Specific definition in the standard SFS 4428

Figure A12

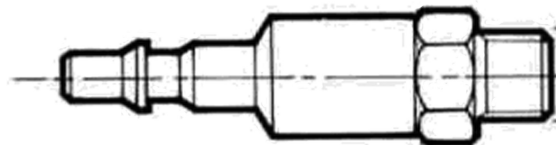
**Rinsing connections for toilet tank**

Quick connector with closing valve, size 3/4"

Material: Acid-proof stainless steel

Sealing on the counter-connector's side

Specific type: Stäubli Faverges RBE11.7154

7.3.2.22. Special requirement for stabling of trains (4.2.11.6)

**Specific case Republic of Ireland and UK for Northern Ireland**

('P') In relation to Section 4.2.11.7 the shore supply of electrical power to stabled trains must fulfil the requirements of IE-CME technical standard 307 or the applicable technical rule in the UK territory of Northern Ireland.

7.3.2.23. Refuelling equipment (4.2.11.7)

**Specific case UK for Great Britain**

('P') Where a vehicle is equipped with a refuelling system, e.g. trains using diesel fuel, alternatively to, or in addition to what is stated in the corresponding clause in chapter 4.2 of this TSI, it is

**▼B**

permissible to use refuelling equipment complying with the requirements of BS 3818:1964 Self-sealing couplings for diesel locomotives and diesel railcars.

This specific case does not prevent the access of TSI compliant rolling stock to the national network.

**Specific case Republic of Ireland and UK for Northern Ireland**

(‘P’) In relation to Section 4.2.11.7 the refuelling equipment interface must fulfil the requirements of IE-CME technical standard 307 or the applicable technical rule in the UK territory of Northern Ireland.

**Specific case Finland**

(‘P’) In order to be able to be refuelled on the Finnish network, the fuel tank of units with a diesel filling interface has to be equipped with the over flow controller according to standards SFS 5684 and SFS 5685.

7.4.

**Specific environmental conditions****Specific conditions Finland**

For unrestricted access of rolling stock on the Finnish network under winter conditions, it shall be demonstrated that the rolling stock meets the following requirements:

- Temperature zone T2 as specified in clause 4.2.6.1.2 shall be selected.
- Snow, ice and hail severe conditions as specified in clause 4.2.6.1.5, excluding the scenario ‘Snowdrift’ shall be selected.
- Regarding humidity, the requirements as specified in clause 4.2.6.1.3 shall be met with the exception of maximum temperature variation taken into consideration, which shall be equal to 60 K.
- Regarding the braking system, requirements of braking performance of this TSI shall be proved to be available for winter-time conditions.

This requirement is deemed to be met if:

- at least one bogie is equipped with a magnetic track brake for trainset or passenger coach of nominal speed exceeding 140 km/h,
- all bogies are equipped with a magnetic track brake for trainset or passenger coach of nominal speed exceeding 180 km/h.

**Specific conditions Sweden**

For unrestricted access of rolling stock on the Swedish network under winter conditions, it shall be demonstrated that the rolling stock meets the following requirements:

- Temperature zone T2 as specified in clause 4.2.6.1.2 shall be selected.
- Snow, ice and hail severe conditions as specified in clause 4.2.6.1.5 shall be selected.



**▼B****Specific conditions Austria**

For unrestricted access of rolling stock in Austria under winter conditions,

- the additional capability of the obstacle deflector to remove snow as specified for snow, ice and hail severe conditions in clause 4.2.6.1.5 shall be provided, and
- locomotives and traction units shall be provided with sanding devices.

**Specific conditions Spain**

For unrestricted access to the Spanish network under summer conditions, temperature zone T3 as specified in clause 4.2.6.1.2 shall be selected.

*Note:* The relevant EN standard under drafting process will define particular provisions for the conformity assessment of rolling stock (design and test) to the zone T3, in particular for safety related equipment mounted on the roof or mounted under the train and affected by ‘hot ballast effect’.

**Specific conditions Portugal**

For unrestricted access to the Portuguese network under summer conditions, temperature zone T3 as specified in clause 4.2.6.1.2 shall be selected.

7.5. **Aspects that have to be considered in the revision process or in other activities of the Agency**

Further to the analysis performed during the drafting process of this TSI, particular aspects have been identified as of interest for the future development of the EU railway system.

These aspects are of 3 different groups:

1. Those already subject of a basic parameter in this TSI, with a possible evolution of the corresponding specification when the TSI will be revised.
2. Those not considered in the current state of the art as basic parameter, but which are subject to research projects.
3. Those relevant in the framework of on-going studies related to the EU railway system, which are not in the scope of TSIs.

These aspects are identified below, classified according to the breakdown of the clause 4.2 of the TSI.

7.5.1. *Aspects related to a basic parameter in this TSI*

7.5.1.1. Axle load parameter (clause 4.2.3.2.1)

This basic parameter covers the interface between infrastructure and rolling stock regarding the vertical load.

According to the CR INF TSI, the lines are classified as specified in the standard EN 15528:2008. This standard specifies also a categorisation of railway vehicles, for freight wagons and particular types of locomotives and passenger vehicles; it will be revised to cover all types of rolling stock.

**▼B**

When this revision will be available, it may be of interest to include in the EC certificate delivered by the notified body the 'design' classification of the unit under assessment:

- Classification corresponding to the design mass under normal payload.
- Classification corresponding to the design mass under exceptional payload.

This aspect will have to be considered when revising this TSI, which already requires in its present version to record all data necessary to determine these classifications.

It has to be noted that the requirement to the RU to define and control the operational load, as specified in the clause 4.2.2.5 of the CR OPE TSI will remain unchanged.

#### 7.5.1.2. Track loading limit value (clause 4.2.3.4.2.2)

This set of basic parameters specifies the limit values for track loading (quasi-static guiding force, quasi-static wheel force, maximum wheel force).

The limit values specified are applicable for axle loads in the range of those mentioned in the clause 4.2.2 of the CR INF TSI; for track designed for higher axle loads, harmonised track loading limits values are not defined.

Regarding the quasi-static guiding force, in case the specified limit is exceeded, the operational performance of the rolling stock (e.g. maximum speed) may be limited by the infrastructure, considering track characteristics (e.g. curve radius, cant, rail height).

The specification of these limit values may need to be complemented when revising this TSI.

Regarding the 'quasi-static guiding force', its value is required to be recording in the present revision of the TSI; it will be included in the 'European register of authorised types of vehicles'.

#### 7.5.1.3. Aerodynamic effects (clause 4.2.6.2)

Requirements on 'slipstream effects' and head 'pressure pulse' have been set up in consistency with the HS RST TSI for units of maximum operating speed strictly higher than 160 km/h.

This speed threshold has been defined considering that the return of experience of train operated at higher speed than 160 km/h in the environment of the conventional rail system is very limited.

The return of experience regarding the requirements themselves, and regarding their conformity assessment is expected to increase significantly in the next years, further to the application of the HS RST TSI, and also in the framework of European research projects (Aerotrain).

**▼ B**

Therefore, it is planned when revising this TSI to review the requirements with 2 objectives:

- Ensure that they fit to the operational need of railway undertaking; for example, it may be of interest to define how they may be used to define speed limitations in particular circumstances (train running through a station, through a tunnel, crossing of trains ...).
- Ensure that the conformity assessment can be performed with a good level of accuracy, with a limited number of tests, and preferably by simulations.

7.5.2. *Aspects not related to a basic parameter in this TSI but are subject to research projects*

7.5.2.1. **Additional requirements for security reasons**

The interior of vehicles interfacing with passengers and train crew should provide protection of the occupants in the event of a collision by providing means of:

- minimising the risk of injury due to secondary impact with such furniture and interior fixtures and fittings,
- minimising those injuries that may preclude subsequent escape.

Some EU research projects have been launched in 2006 to study the consequence of railway accidents (collision, derailment ...) on passengers, to evaluate in particular the risk and level of injuries; the objective is to define requirements and corresponding conformity assessment procedures related to the railway vehicles interior layouts and components.

This TSI already provides a number of specifications in order to cover such risks, for example, Sections 4.2.2.5, 4.2.2.7, 4.2.2.9 and 4.2.5.

More recently, studies have been launched at Member State level and at European level (by the Commission Joint Research Centre) regarding the protection of the passengers in the event of terrorist attack.

The Agency will follow these studies, and will consider their outcome to define if additional basic parameters or requirements covering the risk of injuries of passengers in case of accident or terrorist attack shall be recommended to the Commission. Where appropriate this TSI shall be amended.

Pending the revision of this TSI Member States may use national rules to cover such risks. In any case this shall not prevent the access of TSI compliant rolling stock operating across Member State borders onto their national network.

7.5.3. *Aspects relevant for the EU railway system but out of the scope of TSIs*

7.5.3.1. **Track interaction (clause 4.2.3) — Flange or rail lubrication**

During the drafting process of this TSI, it has been concluded that the 'flange or rail lubrication' is not a basic parameter (no link to essential requirements as defined in the Directive).

**▼ B**

Nevertheless, it appears that the actors of the railway sector (IMs, RUs, NSAs) need a support from the Agency in order to move from the current practices to an approach that will ensure transparency and will avoid any unjustified barrier to the circulation of rolling stock on the EU network.

To that end, the Agency has suggested to launch a study together with EIM, with the objective to clarify the key technical and economic aspects of this function, considering the current situation:

- Lubrication is required by some infrastructure managers, but also forbidden by others.
- Lubrication may be provided by means of fixed installation designed by the infrastructure manager or by means of onboard device to be provided by the railway undertaking.
- Environmental aspects have to be considered when releasing grease along the track.

In any case, it is planned to include in the 'Infrastructure Register' information on 'flange or rail lubrication', and the 'European register of authorised types of vehicles' will mention if the rolling stock is fitted with onboard flange lubrication. The study mentioned above will clarify operating rules.

In the meantime, Member States may continue to use national rules in order to cover this issue of the vehicle-track interface. Those rules shall be made available either through notification to the Commission in accordance with Article 17 of Directive 2008/57/EC or through the Infrastructure Register referred to in Article 35 of the same Directive.



*ANNEX A*

**BUFFERS AND SCREW COUPLING SYSTEM**

**A.1. BUFFERS**

When buffers are fitted to a unit end, they shall be paired (i.e. symmetrical and opposite handed) and have the same characteristics.

The height of the centre line of the buffers shall be between 980 mm and 1 065 mm above rail level in all loading and wear conditions.

For car carriers under maximum load and locomotives, the minimum height of 940 mm is allowed.

The standard distance between buffer centrelines shall be nominally 1 750 mm  $\pm$  10 mm symmetrically about the centreline of the vehicle. It is permitted for dual gauge units intended for running between standard gauge networks and broad gauge networks to have a different value of the distance between buffer centrelines (e.g. 1 850 mm), provided that full compatibility with buffers for standard 1 435 mm gauge is ensured.

Buffers shall be sized so that in horizontal curves and reverse curves, it is not possible for vehicles to lock buffers. The minimum horizontal overlap between buffer heads in contact shall be 25 mm.

Assessment test:

The determination of the buffer size has to be made with two vehicles going through a S-curve of 190 m radius without intermediate straight section (track gauge 1,458 m) and in a S-curve of 150 m radius with intermediate straight section of at least 6 m (track gauge 1,470 m).

**A.2. SCREW COUPLING**

The standard screw coupling system between vehicles shall be non-continuous and comprise of a screw coupling permanently attached to the hook, a draw hook and a draw bar with an elastic system.

The height of the centre line of the draw hook shall be between 950 mm and 1 045 mm above rail level in all loading and wear conditions.

For car carriers under maximum load and locomotives, the minimum height of 920 mm is allowed. The maximum height difference of the hook centreline of the vehicle between 'vehicle empty (design mass in working order) with new wheels' and 'vehicle loaded (normal design payload) with fully worn wheels' shall not exceed 85 mm for the same vehicle. Assessment shall be done by calculation.

Each vehicle end shall have a facility for supporting a shackle when it is not in use. No part of the coupler assembly shall reach below 140 mm above rail level in the lowest admissible position of the buffers.

— Screw coupling, draw hook and draw gear dimensions and characteristics shall be according to EN15566:2009.

— The maximum weight of the screw coupling shall not exceed 36 kg, not including the weight of the coupling hook pin (item No 1 on figures 4 and 5 of EN15566:2009).

**▼B****A.3. INTERACTION OF DRAW- AND BUFFING-GEAR**

- Static characteristics of draw gears and buffers shall be coordinated in order to ensure that a train is able to negotiate curves of the minimum radius defined in clause 4.2.3.6 of this TSI safely in normal coupling conditions (e.g. without locking buffers, etc.)
- Screw coupling and buffing gear layout:

The distance between the front edge of a draw-hook opening and the front side of the fully extended buffers shall be  $355 \text{ mm} + 45/-20 \text{ mm}$  in the new condition as shown in figure A1.

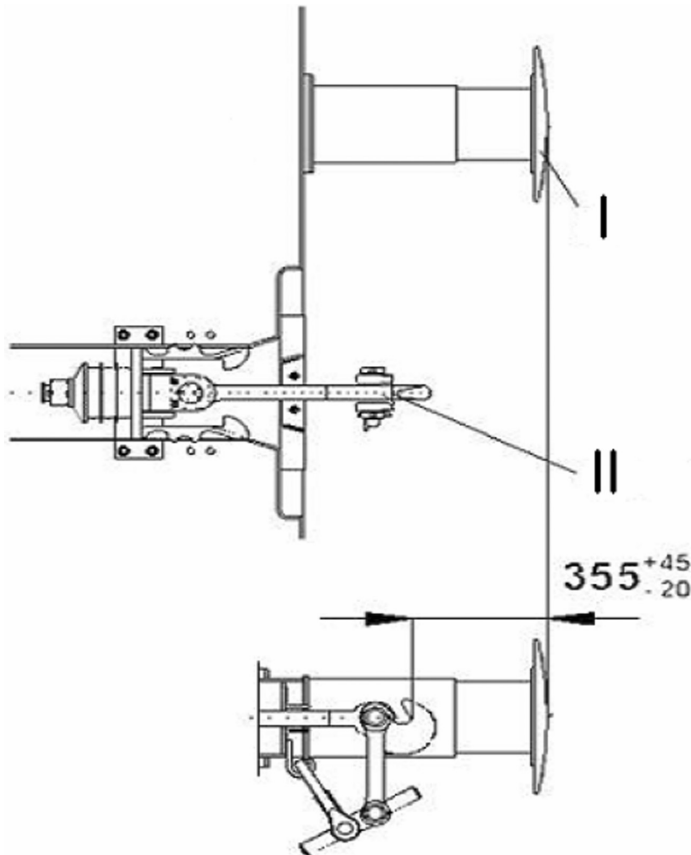
**Structures and mechanical parts****Buffers***Figure A1***Draw gear and buffers**

- I Fully extended buffer
- II Draw-hook opening

▼B

Figure A2  
Bern rectangle

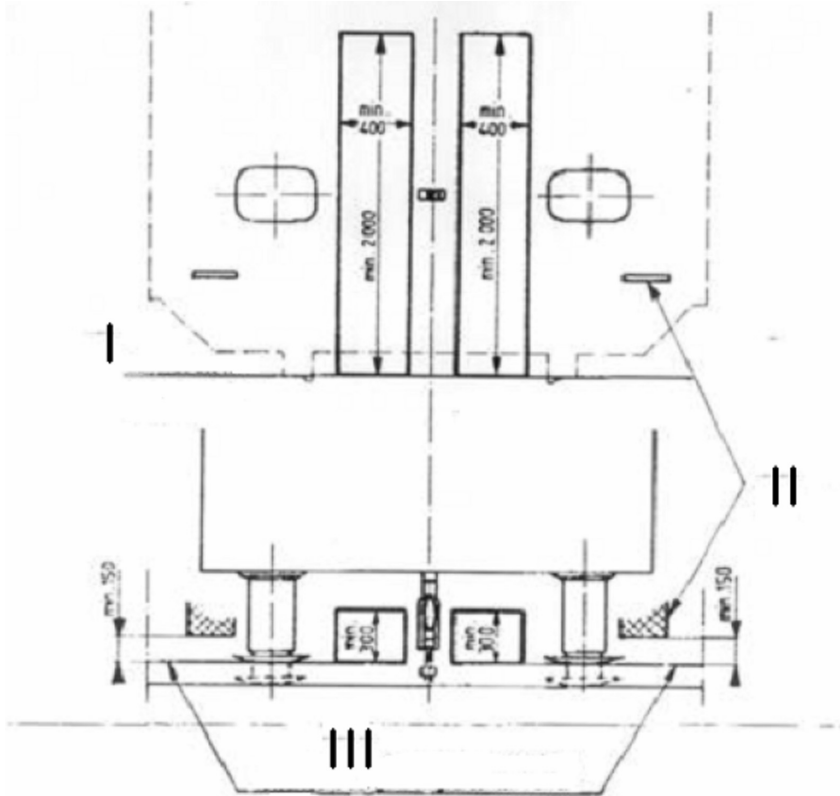

I Top of rail

II Step

III Contact plane of fully compressed buffers

**▼B***ANNEX B***LIFTING AND JACKING POINTS**

*Note:* The following data will be subject of an EN standard currently under drafting process.

**B.1. DEFINITIONS****B.1.1. Re-railing**

Re-railing is the operation consisting in raising and translating a derailed railway vehicle in order to put it back on rails. This operation is carried out at the site of the incident, by means of rescue equipment used by specialised rescue teams.

**B.1.2. Recovery**

The process of clearing the railway line of a vehicle that has been immobilised as a result of collision, derailment, accident or other incident.

**B.1.3. Jacking and lifting points**

Particular location points provided on the vehicle to locate jacking/lifting devices allowing in particular the raising of the vehicle with help of the rescue equipment.

*Note:* It is permitted to use these jacking/lifting points for other purposes (e.g. maintenance in workshops, etc.)

**B.2. IMPACT OF RE-RAILING ON THE DESIGN OF ROLLING STOCK**

It shall be possible to safely re-rail each vehicle by a variety of means incl. lifting by crane or by jacks (jacking), with rescue equipment featuring harmonised interfaces.

To this aim, suitable bodyshell interfaces shall be provided, which permit the application of vertical or quasi-vertical forces.

Furthermore the vehicle shall be designed for complete lifting, including the running gear (e.g. by securing/attaching the bogies to the bodyshell).

**B.3. LOCATION OF JACKING POINTS ON THE STRUCTURES OF VEHICLES**

Fixed or movable jacking points shall be provided for re-railing operations.

— Each jacking point and the structure surrounding it shall withstand without permanent deformation the forces induced by raising the vehicle with the closest running gear secured to the bodyshell of the vehicle.

— *Note:* It is recommended to design jacking points so that they can be used as lifting points with all the running gears of the vehicle linked to the underframe of the vehicle.

Location:

— Jacking/lifting points shall be located such as to enable the safe and stable lifting of the vehicle; sufficient space shall be provided underneath and around each jacking point to allow an easy installation of rescue devices (open point until the corresponding standard is available).



**▼ B**

- Jacking/lifting points shall be designed such that staff is not exposed to any undue risk under normal operation or when using the rescue equipment (open point until the corresponding standard is available).

When the lower structure of the bodyshell does not allow the provision of permanent built-in jacking/lifting points, this structure shall be provided with fixtures which permit the fixation of removable jacking/lifting points during the re-railing operation.

The detailed specification of the location of jacking/lifting points is an open point until the corresponding standard is available.

#### B.4. GEOMETRY OF JACKING/LIFTING POINTS

##### B.4.1. Permanent built-in jacking/lifting points

- Open point.

##### B.4.2. Removable jacking/lifting points

- Open point.

#### B.5. SECURING RUNNING GEARS ONTO THE UNDERFRAME

To facilitate the re-railing of a vehicle, it shall be possible to limit suspension travel (e.g. chains, straps or other loose lifting tackle, etc.)

Detailed technical requirement specification is an open point.

#### B.6. MARKING OF RESCUE JACKING (RESP. LIFTING) POINTS

Each fixed or mobile jacking point shall be marked with one of the following symbols:

- ##### B.6.1. Marking of the points meant for lifting or jacking the whole vehicle with or without running gear:



- ##### B.6.2. Marking of the points meant for lifting or jacking the adjacent end of the vehicle with running gear:



- ##### B.6.3. Marking of the points meant for lifting or jacking the adjacent end of the vehicle without the adjacent running gear:



**▼B****B.7. JACKING AND LIFTING INSTRUCTIONS**

For each type of vehicle, a jacking and lifting diagram shall be provided in the technical documentation as described in clause 4.2.12 of this TSI.

This diagram shall feature at least:

- a longitudinal view of the vehicle showing the location and dimensions of jacking points with indication of the mass at each of these locations,
- a transversal section at each jacking point location with detailed dimensions,
- the description of the jacks and /or lifting apparatuses to be used at each location,
- any particular instruction needed by the rescue team to safely carry out the re-railing.

Instructions shall be given as far as feasible by pictograms.



*ANNEX C*

**SPECIAL PROVISIONS FOR MOBILE RAILWAY INFRASTRUCTURE  
CONSTRUCTION AND MAINTENANCE EQUIPMENT**

**C.1. STRENGTH OF VEHICLE STRUCTURE**

The requirements of the clause 4.2.2.4 of this TSI are complemented as follow:

The machine frame shall be able to withstand either the static loads of EN 12663-1:2010, clauses 6.1 to 6.5 or the static loads according to EN 12663-2:2010, clauses 5.2.1 to 5.2.4 without exceeding the permissible values given there in.

The corresponding structural category of EN 12663-2 is as follows:

- for machines not permitted to be loose shunted or hump shunted: F-II,
- for all other machines: F-I.

The acceleration in x-direction according to EN12663-1:2010, table 13 or EN12663-2:2010, table 10 shall be 3 g.

**C.2. LIFTING AND JACKING**

The machine body shall incorporate lifting points by which the whole machine is capable of being safely lifted or jacked. The location of the lifting and jacking points shall be defined.

To facilitate the work during repair or inspection or when on-tracking the machines, the machines shall be provided on both long sides with at least two lifting points, at which the machines can be lifted in empty or loaded condition. These lifting points must be identified, as described in Annex B of this TSI.

These lifting points should be provided where possible at a distance of 1 400 mm from the middle of the individual wheelsets.

To allow positioning of jacking devices, clearances shall be provided under the lifting points which shall not be blocked by the presence of non-removable parts. The load cases shall be consistent with the ones chosen in Annex C.1 of this TSI and shall apply for lifting and jacking under workshop and servicing operations.

**C.3. RUNNING DYNAMIC BEHAVIOUR**

The running characteristics are permitted to be determined by running tests or by reference to a similar type approved machine as detailed in clause 4.2.3.4.2 of this TSI or by simulation.

The following additional deviations from EN 14363:2005 apply:

- the test shall always be taken as the simplified method for this type of machines,
- when running tests according to EN 14363:2005 are done with wheel profile in new condition, these are valid for a maximum distance of 50 000 km. After 50 000 km it is necessary to:
  - either re-profile the wheels,
  - or calculate the equivalent conicity of the worn profile and check that it does not differ more than 50 % from the value of the test of EN 14363:2005 (with a maximum difference of 0,05),

**▼ B**

- or make a new test according to EN 14363:2005 with worn wheel profile,
- in general, stationary tests to determine the parameters of characteristic running gear in accordance with EN 14363:2005, 5.4.3.2 are not necessary,
- if the required test speed cannot be obtained by the machine itself, the machine shall be hauled for the tests,
- when test zone 3 (as described in table 9 of EN14363:2005) is used it is sufficient to have a minimum of 25 conformant track sections.

Running behaviour can be proven by simulation of the tests described in EN14363:2005 (with the exceptions as specified above) when there is a validated model of representative track and operating conditions of the machine.

A model of a machine for simulation of running characteristics shall be validated by comparing the model results against the results of a running test when the same input of track characteristic is used.

A validated model is a simulation model that has been verified by an actual running test that excites the suspension sufficiently and where there is a close correlation between the results of the running test and the predictions from the simulation model over the same test track.

**▼ B***ANNEX D***ENERGY METER****1. Introduction**

- 1.1. The onboard energy measuring system (EMS) is the system for measurement of electric energy taken from or returned (during regenerative braking) to the overhead contact line (OCL) by the traction unit, supplied from the external electric traction system.

The functions of the system are:

- 1.1.1. Energy measurement function (EMF), including voltage and current measurement and calculation of energy data;
- 1.1.2. Data handling system (DHS), merging data from the EMF with time data and geographical position, producing and storing the complete series of data with true energy values (in kWh/kVarh) ready to be sent by a communication system;
- 1.1.3. Onboard location function, giving geographical position of the traction unit;

The abovementioned function elements may be performed by individual devices or may be combined in one or more integrated assemblies.

*Figure 1*

**Energy measuring system functional diagram**

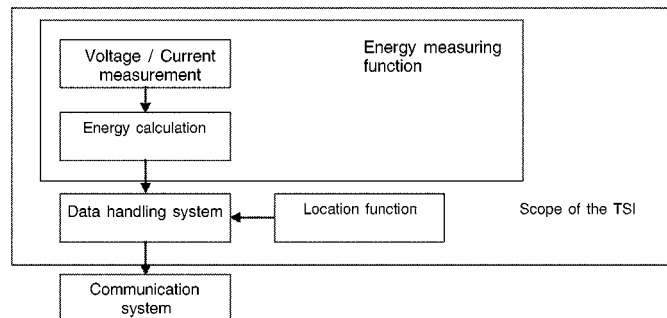
**2. Requirements for onboard energy measuring system (EMS)**

- 2.1. *Energy measuring function (EMF)*
- 2.1.1. The onboard measuring system shall include an EMF containing the elements described in clause 1.1.1 of the present Annex D.
- 2.1.2. The EMF shall measure energy supplied by all electric traction systems for which the traction unit is designed.
- 2.1.3. The EMF shall be connected in such a way that all energy (traction and auxiliary) supplied to the train from the OCL and regenerated is recorded; for AC energy measuring system the reactive energy shall be recorded too.
- 2.1.4. The EMF shall have a total accuracy of 1,5 % for AC for active energy and 2,0 % for DC (or lower percentage of error).

**▼ B**

These accuracies shall be determined in accordance with the following formula:

$$\varepsilon_{EMF} = \sqrt{\varepsilon_{VMF}^2 + \varepsilon_{CMF}^2 + \varepsilon_{ECF}^2}$$

Where:

- $\varepsilon_{EMF}$  = total accuracy of EMF,
- $\varepsilon_{VMF}$  = the maximum percentage error of the voltage measurement function (VMF),
- $\varepsilon_{CMF}$  = the maximum percentage error of the current measurement function (CMF),
- $\varepsilon_{ECF}$  = the maximum percentage error of the energy calculation function (ECF).

2.1.4.1. The abovementioned maximum percentage errors of the individual functions shall be fulfilled under the following reference conditions:

- any voltage in between  $U_{\min 1}$  and  $U_{\max 2}$ , with  $U_{\min 1}$  and  $U_{\max 2}$  as defined in EN 50163:2004 clause 4.1, table 1,
- any current in between 10 % and 120 % of the rated primary current of the EMF,
- frequency  $\pm 0,3$  % relating to the frequencies of the permitted traction supply systems according to CR energy TSI clause 4.2.3,
- power factor in between 0,85 and 1,
- ambient temperature of  $23 \text{ }^\circ\text{C} \pm 2 \text{ }^\circ\text{C}$ .

2.1.4.2. The EMS rated current and voltage shall be matched to the traction unit rated current and voltage.

2.1.5. The elements used to implement the EMF are subject to legal metrological control, which shall be executed in accordance with the following:

2.1.5.1. Accuracy of each element shall be tested under reference conditions according to clause 2.1.4.1 of the present Annex D, to verify that they are within their declared maximum error.

2.1.5.2. Each element which complies with clause 2.1.5.1 of the present Annex D shall be marked, to indicate metrological control and the declared maximum error limit.

2.1.5.3. The configuration of each element shall be documented as a part of the metrological control.

2.1.6. The EMF shall have a time reference period of 5 minutes defined by the UTC clock time at the end of each reference period; one of the time reference period shall end at 24:00:00.

It is permitted to use a shorter time reference if the data can be aggregated into 5 minutes reference period.

2.1.7. The EMF shall be protected from non-authorized access to the system and data.

2.2. *Data handling system (DHS)*

2.2.1. The onboard measuring system shall include a DHS providing the functions described in clause 1.1.2 of the present Annex D.

**▼ B**

- 2.2.2. The DHS shall compile the energy measured data with other data without corrupting them;
- 2.2.3. The DHS shall use, as a time reference, the same source of clock as in the EMF;
- 2.2.4. The DHS shall incorporate a data storage with a memory capacity sufficient to store data of at least 60 days (irrespective of the time reference used) continuous work and consisting of consumed/regenerated active and reactive (if appropriate) energy, together with time reference and location data;
- 2.2.5. The DHS shall have a capability to be interrogated locally by authorised personnel on board the train using appropriate equipment (e.g. laptop computer) in order to provide an opportunity for audit, and an alternative method of recovering data.
- 2.2.6. The compiled data suitable for energy billing shall be stored ready to be transferred in chronological order according to the end times of each 5 minutes time reference period in accordance with clause 2.1.6 of the present Annex D and shall contain:
  - 2.2.6.1. unique unit number including the European vehicle number;
  - 2.2.6.2. end time of each elapsed measuring period for energy, defined as year, month, day, hour, minute and second;
  - 2.2.6.3. the location data as specified in clause 2.3.3 of the present Annex D at the end of each measuring period;
  - 2.2.6.4. consumed/regenerated active and reactive (if appropriate) energy in each time period.
- 2.3. *Location function*
  - 2.3.1. The location function is described in clause 1.1.3 of the present Annex D.
  - 2.3.2. The data from the location function shall be synchronised in accordance with UTC clock time and time period) with the onboard EMF.
  - 2.3.3. The location function shall provide the position expressed in latitude and longitude
  - 2.3.4. In open air the location function shall have an accuracy of 250 m or less.
- 2.4. *Other requirements*
  - 2.4.1. It is permissible to access the data in the DHS for other purposes (e.g. feedback to the driver) in connection with the efficient operation of the train, provided that it can be demonstrated that the integrity of recorded and transmitted data as listed in clause 2.2.6 of the present Annex D is not compromised by this arrangement;
  - 2.4.2. The data listed in clause 2.2.6 of the present Annex shall be retained even when the energy measuring system is isolated from its power supply.
- 2.5. *Conformity assessment of complete onboard energy measuring system*
  - 2.5.1. Conformity assessment of the complete onboard energy measuring system (EMS) shall be assessed by a design review and type test of the EMS elements, including evidence of metrological control of the elements used to implement the EMF. The configuration of the EMS shall be documented as a part of the conformity assessment.

**▼B**

- 2.5.2. The declared maximum error limit for each element of an EMF, verified in accordance with clause 2.1.5.1 of the present Annex D, shall be inserted in the formula in clause 2.1.4 of the present Annex D, to check that the total accuracy is within the stated limit.



**▼B**

*ANNEX E*

**ANTHROPOMETRIC MEASUREMENTS OF THE DRIVER**

The following data represents the ‘state of the art’ and shall be used.

*Note:* They will be subject of an EN standard currently under drafting process.

**1. Principal anthropometric measurements of the shortest and tallest driving staff**

The dimensions given in Appendix E of the UIC 651(4th edition, July 2002) shall be taken into consideration.

**2. Additional anthropometric dimensions of the shortest and tallest driving staff**

The dimensions given in Appendix G of the UIC 651(4th edition, July 2002) shall be taken into consideration.

**▼ B***ANNEX F***FRONT VISIBILITY**

The following data represents the 'state of the art' and shall be used.

*Note:* They will be subject of an EN standard currently under drafting process.

**F.1. General**

- The design of the cab shall support the drivers' view of all external information that form part of the driving task as well as protecting the driver from external sources of visual interference. This shall include the following:
  - Flicker at the lower edge of the windscreen, which can cause fatigue, shall be reduced.
  - Protection shall be provided from the sun and glare of headlights from oncoming trains, without reducing the drivers' view of external signs, signals and other visual information.
  - Location of cab equipment shall not block or distort the drivers view of external information.
  - The dimension, location, shape and finishes (including maintenance) of the windows shall not inhibit the drivers external view and shall support the driving task.
  - The location, type and quality of windscreen cleaning and clearance devices shall ensure that the driver is able to maintain a clear external view in most weather and operating conditions, and shall not inhibit the drivers external view.
- The driver's cab shall be designed in such a way that the driver is facing forwards when driving.
- The driver's cab shall be designed to allow the driver at his seated driving position a clear and unobstructed line of sight in order to distinguish fixed signals set to both the left and right of the track, as defined in Appendix D of the UIC 651(4th edition, July 2002).

*Note:* The position of the seat in the Appendix D mentioned here above has to be considered as an example; the TSI does not impose the position of the seat (left, central or right) in the cab.

The rules expressed in the Annex above govern the conditions of visibility for each running direction along straight track and in curves with a radius of 300 m and more. They apply to the position(s) of the driver.

*Note:* In case of cab fitted with 2 drivers' seats, they apply to the 2 seated positions.

**F.2. Reference position of vehicle in relation to track**

The clause 3.2.1 of the UIC 651(4th edition, July 2002) shall apply.

The supplies and payload shall be considered as defined in EN 15663:2009 and clause 4.2.2.10 of this TSI.

**▼B**

**F.3. Reference position for the eyes of crew members**

The clause 3.2.2 of the UIC 651(4th edition, July 2002) shall apply.

The distance from the driver's eyes in seating posture to the windscreen shall be higher than or equal to 500 mm.

**F.4. Conditions of visibility**

The clause 3.3 of the UIC 651(4th edition, July 2002) shall apply.

**▼B**

*ANNEX G*

Reserved



## ANNEX H

## ASSESSMENT OF THE ROLLING STOCK SUBSYSTEM

## H.1. Scope

This Annex indicates the assessment of conformity of the rolling stock subsystem.

## H.2. Characteristics and modules

The subsystem characteristics to be assessed in the different phases of design, development and production are marked by X in table H.1. A cross in column 4 of table H.1 indicates that the relevant characteristics shall be verified by testing each single subsystem.

Table H.1

## Assessment of the rolling stock subsystem

1		2	3	4	5
Characteristics to be assessed, as specified in clause 4.2 of this TSI		Design and development phase		Production phase	Particular assessment procedure
		Design review	Type test	Routine test	
Element of the rolling stock subsystem	Clause				Clause
<b>Structure and mechanical parts</b>	<b>4.2.2</b>				
Inner coupling	4.2.2.2.2	X	n.a.	n.a.	—
End coupling	4.2.2.2.3	X	n.a.	n.a.	—
Rescue coupling	4.2.2.2.4	X	X	n.a.	—
Staff access for coupling and uncoupling	4.2.2.2.5	X	X	n.a.	—
Gangways	4.2.2.3	X	X	n.a.	—
Strength of vehicle structure	4.2.2.4	X	X	n.a.	—
Passive safety	4.2.2.5	X	X	n.a.	—
Lifting and jacking	4.2.2.6	X	X	n.a.	—
Fixing of devices to car body structure	4.2.2.7	X	n.a.	n.a.	—
Access doors	4.2.2.8	X	X	n.a.	—
Mechanical characteristics of glass	4.2.2.9	X	n.a.	n.a.	—
Load conditions and weighted mass	4.2.2.10	X	X	X	6.2.2.2.1
<b>Track interaction and gauging</b>	<b>4.2.3</b>				
Kinematic gauge	4.2.3.1	X	n.a.	n.a.	6.2.2.2.2
Wheel load	4.2.3.2.2	X	X	n.a.	6.2.2.2.3
Rolling stock parameters which influence CCS subsystem	4.2.3.3.1	X	X	X	—
Axle bearing condition monitoring	4.2.3.3.2	X	X	n.a.	—
Safety against derailment running on twisted track	4.2.3.4.1	X	X	n.a.	—

## ▼B

1		2	3	4	5
Characteristics to be assessed, as specified in clause 4.2 of this TSI		Design and development phase		Production phase	Particular assessment procedure
		Design review	Type test	Routine test	
Element of the rolling stock subsystem	Clause				Clause
Running dynamic behaviour	4.2.3.4.2	X	X	n.a.	—
Limit values for running safety	4.2.3.4.2.1	X	X	n.a.	—
Track loading limit values	4.2.3.4.2.2	X	X	n.a.	—
Equivalent conicity	4.2.3.4.3	X	n.a.	n.a.	—
Design values for new wheel profiles	4.2.3.4.3.1	X	n.a.	n.a.	—
In-service values of wheelset equivalent conicity	4.2.3.4.3.2	open	open	open	open
Structural design of bogie frame	4.2.3.5.1	X	X.	n.a.	—
Mechanical and geometrical characteristics of wheelsets	4.2.3.5.2.1	X	X	X	—
Mechanical and geometrical characteristics of wheels	4.2.3.5.2.2	X	X	X	—
Variable gauge wheelsets	4.2.3.5.2.3	open	open	open	open
Minimum curve radius	4.2.3.6	X	n.a.	n.a.	—
Life guards	4.2.3.7	X	n.a.	n.a.	—
<b>Braking</b>	<b>4.2.4</b>				
Functional requirements	4.2.4.2.1	X	X	n.a.	—
Safety requirements	4.2.4.2.2	X	n.a.	n.a.	6.2.2.2.4
Type of brake system	4.2.4.3	X	X	n.a.	—
<b>Brake command</b>	<b>4.2.4.4</b>				
Emergency braking	4.2.4.4.1	X	X	X	—
Service braking	4.2.4.4.2	X	X	X	—
Direct braking command	4.2.4.4.3	X	X	X	—
Dynamic braking command	4.2.4.4.4	X	X	n.a.	—
Parking braking command	4.2.4.4.5	X	X	X	—
<b>Braking performance</b>	<b>4.2.4.5</b>				
General requirements	4.2.4.5.1	X	n.a.	n.a.	—
Emergency braking	4.2.4.5.2	X	X	X	6.2.2.2.5
Service braking	4.2.4.5.3	X	X	X	6.2.2.2.6
Calculations related to thermal capacity	4.2.4.5.4	X	n.a.	n.a.	—



1		2	3	4	5
Characteristics to be assessed, as specified in clause 4.2 of this TSI		Design and development phase		Production phase	Particular assessment procedure
		Design review	Type test	Routine test	
Element of the rolling stock subsystem	Clause				Clause
Parking brake	4.2.4.5.5	X	n.a	n.a	—
Limit of wheel rail adhesion profile	4.2.4.6.1	X	n.a	n.a	—
Wheel slide protection system	4.2.4.6.2	X	X	n.a	6.2.2.2.7
Wheel slide protection system (IC)	5.3.3	X	X	X	6.1.2.2.1
Interface with traction — Braking systems linked to traction (electric, hydro-dynamic)	4.2.4.7	X	X	n.a	—
<b>Braking system independent of adhesion conditions</b>	<b>4.2.4.8</b>				
General	4.2.4.8.1.	X	n.a	n.a	—
Magnetic track brake	4.2.4.8.2.	X	X	n.a	—
Eddy current track brake	4.2.4.8.3	open	open	open	open
Brake state and fault indication	4.2.4.9	X	X	n.a	—
Brake requirements for rescue purposes	4.2.4.10	X	X	n.a	—
<b>Passenger related items</b>	<b>4.2.5</b>				
Sanitary systems	4.2.5.1	X	n.a	n.a	6.2.2.2.8
Public address system: audible communication system	4.2.5.2	X	X	X	—
Passenger alarm: functional requirements	4.2.5.3	X	X	X	—
Safety instructions to passengers — Signs	4.2.5.4	X	n.a	n.a	—
Communication devices for passengers	4.2.5.5	X	X	X	—
Exterior doors: access to and egress from rolling stock	4.2.5.6	X	X	X	—
Door system construction	4.2.5.7	X	n.a	n.a	—
Inter-unit doors	4.2.5.8	X	X	n.a	—
Internal air quality	4.2.5.9	X	n.a	n.a	6.2.2.2.9
Body side windows	4.2.5.10	X			—
<b>Environmental conditions and aerodynamic effects</b>	<b>4.2.6</b>				



1		2	3	4	5
Characteristics to be assessed, as specified in clause 4.2 of this TSI		Design and development phase		Production phase	Particular assessment procedure
		Design review	Type test	Routine test	
Element of the rolling stock subsystem	Clause				Clause
<b>Environmental conditions</b>	<b>4.2.6.1</b>				
Altitude	4.2.6.1.1	X	n.a.	n.a.	—
Temperature	4.2.6.1.2	X	n.a. /X <sup>(1)</sup>	n.a.	—
Humidity	4.2.6.1.3	X	n.a.	n.a.	—
Rain	4.2.6.1.4	X	n.a.	n.a.	—
Snow, ice and hail	4.2.6.1.5	X	n.a. / X <sup>(1)</sup>	n.a.	—
Solar radiation	4.2.6.1.6	X	n.a.	n.a.	—
Resistance to pollution	4.2.6.1.7	X	n.a.	n.a.	—
<b>Aerodynamic effects</b>	<b>4.2.6.2</b>				
Slipstream effects on passengers on platform	4.2.6.2.1	X	X	n.a.	6.2.2.2.10
Slipstream effects on workers at the track side	4.2.6.2.2	X	X	n.a.	6.2.2.2.11
Head pressure pulse	4.2.6.2.3	X	X	n.a.	6.2.2.2.12
Maximum pressure variations in tunnels	4.2.6.2.4	open	open	open	open
Cross wind	4.2.6.2.5	open	open	open	open
<b>External lights and visible and audible warning devices</b>	<b>4.2.7</b>				
<b>External front and rear lights</b>	<b>4.2.7.1</b>				
Head lights	4.2.7.1.1	X	X	n.a.	6.1.2.2.2
Marker lights	4.2.7.1.2	X	X	n.a.	6.1.2.2.3
Tail lights	4.2.7.1.3	X	X	n.a.	6.1.2.2.4
Lamp controls	4.2.7.1.4	X	X	n.a.	—
<b>Horn</b>	<b>4.2.7.2</b>				
General	4.2.7.2.1	X	X	n.a.	—
Warning horn sound pressure levels	4.2.7.2.2	X	X	n.a.	6.1.2.2.5
Protection	4.2.7.2.3	X	n.a.	n.a.	—
Control	4.2.7.2.4	X	X	n.a.	—
<b>Traction and electrical equipment</b>	<b>4.2.8</b>				
<b>Traction performance</b>	<b>4.2.8.1</b>				



▼**B**

1		2	3	4	5
Characteristics to be assessed, as specified in clause 4.2 of this TSI		Design and development phase		Production phase	Particular assessment procedure
		Design review	Type test	Routine test	
Element of the rolling stock subsystem	Clause				Clause
<b>General</b>	<b>4.2.8.1.1</b>				
Requirements on performance	4.2.8.1.2	X	n.a	n.a	—
<b>Power supply</b>	<b>4.2.8.2</b>				
General	4.2.8.2.1	X	n.a	n.a	—
Operation within range of voltages and frequencies	4.2.8.2.2	X	X	n.a	—
Regenerative brake with energy to the overhead contact line	4.2.8.2.3	X	X	n.a	—
Maximum power and current from the overhead contact line	4.2.8.2.4	X	X	n.a	6.2.2.2.13
Maximum current at standstill for DC systems	4.2.8.2.5	X	X	n.a	—
Power factor	4.2.8.2.6	X	X	n.a	6.2.2.2.14.
System energy disturbances	4.2.8.2.7	X	X	n.a	—
Energy consumption measuring function	4.2.8.2.8	X	X	n.a	—
Requirements linked to pantograph	4.2.8.2.9	X	X	n.a	6.2.2.2.15 and 16
Pantograph (IC)	5.3.8	X	X	X	6.1.2.2.6
Contact strips (IC)	5.3.8.1	X	X	X	6.1.2.2.7
Electrical protection of the train	4.2.8.2.10	X	X	n.a	—
Diesel and other thermal traction system	4.2.8.3	—	—	—	Other Directive
Protection against electrical hazards	4.2.8.4	X	X	n.a	—
<b>Cab and operation</b>	<b>4.2.9</b>				
Driver's cab	4.2.9.1	X	n.a	n.a	—
General	4.2.9.1.1	X	n.a	n.a	—
Access and egress	4.2.9.1.2	X	n.a	n.a	—
Access and egress in operating conditions	4.2.9.1.2.1	X	n.a	n.a	—
Driver's cab emergency exit	4.2.9.1.2.2	X	n.a	n.a	—
External visibility	4.2.9.1.3	X	n.a	n.a	—

▼B

1		2	3	4	5
Characteristics to be assessed, as specified in clause 4.2 of this TSI		Design and development phase		Production phase	Particular assessment procedure
		Design review	Type test	Routine test	
Element of the rolling stock subsystem	Clause				Clause
Front visibility	4.2.9.1.3.1	X	n.a	n.a	—
Rear and side view	4.2.9.1.3.2	X	n.a	n.a	—
Interior layout	4.2.9.1.4	X	n.a	n.a	—
Driver's seat	4.2.9.1.5	X	n.a	n.a	—
Driver's desk — Ergonomics	4.2.9.1.6	X	n.a	n.a	—
Climate control and air quality	4.2.9.1.7	X	X	n.a	6.2.2.2.9
Internal lighting	4.2.9.1.8	X	X	n.a	—
Windscreen — Mechanical characteristics	4.2.9.2.1	X	X	n.a	6.2.2.2.17
Windscreen — Optical characteristics	4.2.9.2.2	X	X	n.a	6.2.2.2.17
Front end — Equipment	4.2.9.2.3	X	X	n.a	—
<b>Driver machine interface</b>	<b>4.2.9.3</b>				
Driver's activity control function	4.2.9.3.1	X	X	X	—
Speed indication	4.2.9.3.2	—	—	—	—
Driver display unit and screens	4.2.9.3.3	X	X	n.a	—
Controls and indicators	4.2.9.3.4	X	X	n.a	—
Labelling	4.2.9.3.5	X	n.a	n.a	—
Remote control function	4.2.9.3.6	X	X	n.a	—
Onboard tools and portable equipment	4.2.9.4	X	n.a	n.a	—
Storage facility for staff personal effects	4.2.9.5	X	n.a	n.a	—
Recording device	4.2.9.6	open	open	open	open
<b>Fire safety and evacuation</b>	<b>4.2.10</b>				
General and categorisation	4.2.10.1	X	n.a	n.a	—
Material requirements	4.2.10.2	X	X	n.a	—
Specific measures for flammable liquids	4.2.10.3	X	X	n.a	—

▼**B**

1		2	3	4	5
Characteristics to be assessed, as specified in clause 4.2 of this TSI		Design and development phase		Production phase	Particular assessment procedure
		Design review	Type test	Routine test	
Element of the rolling stock subsystem	Clause				Clause
Passenger evacuation	4.2.10.4	X	n.a	n.a	—
Fire barriers	4.2.10.5	X	X	n.a	6.2.2.2.18
<b>Servicing</b>	<b>4.2.11</b>				
Cleaning of driver's cab windscreen	4.2.11.2	X	X	n.a	—
Toilet discharge system	4.2.11.3	X	n.a	n.a	—
Water refilling equipment	4.2.11.4	X	n.a	n.a	—
Interface for water refilling	4.2.11.5	X	n.a	n.a	—
Special requirements for stabling of trains	4.2.11.6	X	X	n.a	—
Refuelling equipment	4.2.11.7	X	n.a	n.a	—
<b>Documentation for operation and maintenance</b>	<b>4.2.12</b>				
General	4.2.12.1	X	n.a	n.a	—
General documentation	4.2.12.2	X	n.a	n.a	—
Maintenance file	4.2.12.3	X	n.a	n.a	—
The maintenance design justification file	4.2.12.3.1	X	n.a	n.a	—
The maintenance documentation	4.2.12.3.2	X	n.a	n.a	—
Operating documentation	4.2.12.4	X	n.a	n.a	—

(1) Type test if and as defined by the applicant.



## ANNEX I

## ASPECTS FOR WHICH THE TECHNICAL SPECIFICATION IS NOT AVAILABLE (OPEN POINTS)

## General open points that relate to a complete network

Element of the rolling stock subsystem	Clause of this TSI	Technical aspect not covered by this TSI	Comments
Specific requirements for CR RST to operate safely on the HS network	1.2	All requirements	Compatibility with concerned network
Specific case Estonia, Latvia, Lithuania, Poland and Slovakia for 1 520 mm system	7.3.2	All clauses of the TSI are open points	Open point to indicate that further work is needed for 1 520 mm system

## Open points that relate to technical compatibility between the vehicle and the network

Element of the rolling stock subsystem	Clause of this TSI	Technical aspect not covered by this TSI	Comments
Axle bearing condition monitoring	4.2.3.3.2 4.2.3.5.2.1	Range of working temperature for trackside equipment	Temperature limit recorded in the technical documentation. Compatibility with concerned network to be checked
Running dynamic behaviour	4.2.3.4.2	Reference track for tests (track geometric quality)	Test report includes the description of the test track conditions. To be examined to verify compatibility with concerned network
Running dynamic behaviour	4.2.3.4.2	The combination of speed, curvature and cant deficiency according to EN 14363	Test report includes the description of the test track. To be examined to verify compatibility with concerned network
Wheelsets — Equivalent conicity	4.2.3.4.3.2	In-service value of wheelset equivalent conicity	Maintenance criteria to be defined depending on the networks conditions
Braking system independent of adhesion conditions	4.2.4.8.3	Eddy current track brake	Equipment not mandatory. Compatibility with concerned network to be checked
Pantograph lowering	4.2.8.2.9.10	Mandatory presence of an automatic dropping device (ADD)	ADD accepted on the CR TEN; not mandatory everywhere (national rule)

▼ **B****Open points that do not relate to technical compatibility between the vehicle and the network**

Element of the rolling stock subsystem	Clause of this TSI	Technical aspect not covered by this TSI	Comments
Safety related functions	4.2.1	Safety level not specified in clauses: — 4.2.3.4 (dynamic behaviour; design option with software)	— Design option <sup>(1)</sup>
Safety related functions	4.2.1	— 4.2.4.9 (braking; option centralised control system)	— Design option <sup>(1)</sup>
Safety related functions	4.2.1	— 4.2.5.3 (design option for alarm)	— Design option <sup>(1)</sup>
Safety related functions	4.2.1	— 4.2.5.6 (door control system described in points D and E)	
Safety related functions	4.2.1	— 4.2.8.2.10 (control of main circuit breaker)	
Safety related functions	4.2.1	— 4.2.9.3.1 (driver's activity control)	
Safety related functions	4.2.1	— 4.2.10.5 (design option other than full partition)	— Design option <sup>(1)</sup>
Passive safety	4.2.2.5	Application of scenarios 1 and 2 to heavy haul freight locomotives with centre couplers	If not closed before granting authorisation of placing in service (no technical solution available), possible restrictions at the level of operation <sup>(3)</sup>
Passive safety	4.2.2.5	Assessment of compliance of locomotives with centre cab with requirements related to scenario 3	If not closed before granting authorisation of placing in service (no technical solution available), possible restrictions at the level of operation <sup>(3)</sup>
Jacking and lifting equipment interfaces	4.2.2.6 Annex B	Location and geometry of the interfaces	Described in the technical documentation; to be considered for operation and maintenance <sup>(2)</sup>
Axle bearing condition monitoring	4.2.3.3.2	Option onboard equipment	Design option <sup>(1)</sup>
Variable gauge wheelsets	4.2.3.5.2.3	Conformity assessment	Design option <sup>(1)</sup>
Slipstream effect on passengers on platform (for speed higher than 160 km/h)	4.2.6.2.1	Slipstream effects for units assessed for general operation (train formation not defined)	Train formation for assessment of the single unit not defined Possible restrictions at the level of operation <sup>(3)</sup>

## ▼ B

Element of the rolling stock subsystem	Clause of this TSI	Technical aspect not covered by this TSI	Comments
Slipstream effect on workers at trackside (for speed higher than 160 km/h)	4.2.6.2.2	Slipstream effects for units assessed for general operation (train formation not defined)	Train formation for assessment of the single unit not defined Possible restrictions at the level of operation <sup>(3)</sup>
Cross wind	4.2.6.2.5	Cross wind effect for all CR rolling stock: harmonised characteristics of wind to be considered and assessment method	To be closed before granting authorisation of placing in service by indication of the cross wind considered in the design (as required in this TSI) Compatibility with operating conditions to be checked; possible measures at the level of infrastructure or operation <sup>(2)</sup>
Pantograph — Contact strip material	4.2.8.2.9.4	Other material to be used on AC and/or DC lines	If other material used, verification by application of national rules Described in the technical documentation; to be considered for operation and maintenance <sup>(2)</sup>
Recording device	4.2.9.6	Specification of the recording device and of its integration in the rolling stock	Open point in the revision of the Operation TSI (to be adopted) See also Directive 2008/57/EC, Article 23(3)(b)
Special requirements for stabling of trains	4.2.11.6	Local external power supply 400 V (waiting for conclusion of Modtrain study)	Described in the technical documentation; to be considered for operation and maintenance <sup>(2)</sup>
Refuelling	4.2.11.7	Nozzles for other fuels than diesel fuel	Described in the technical documentation; to be considered for operation and maintenance <sup>(2)</sup>

<sup>(1)</sup> Interoperability is ensured by the technical solution fully specified in the clause 4.2 of the TSI.

This open point relates to an alternative technical solution, for which there is not yet a harmonised specification. The use of this alternative solution is a choice of the applicant.

<sup>(2)</sup> This open point relates to technical aspects that may have an impact on operation and/or maintenance; the technical solution used has to be described in the technical documentation provided with the EC declaration of verification, in order to be taken into account at operational level.

<sup>(3)</sup> This open point relates to technical aspects for which the current state of the art does not provide any technical specification for the rolling stock subsystem; it shall be closed by national rules either before the authorisation of placing in service or by restricting the use of the vehicle.



## ANNEX J

## STANDARDS OR NORMATIVE DOCUMENTS REFERRED TO IN THIS TSI

TSI		Standard	
Characteristics to be assessed		Mandatory reference standard number	Clauses
Element of the rolling stock subsystem	Clause of this TSI		
<b>Structure and mechanical parts</b>	<b>4.2.2</b>		
Inner coupling	4.2.2.2.2	EN 12663-1:2010	Clauses 6.5.3 and 6.7.5 for articulated units
End coupling	4.2.2.2.3 Annex A	EN 15566:2009	Buffer and screw coupling
		EN 15551:2009	Buffer and screw coupling
		UIC 541-1:Nov 2003	Dimension and layout of brake pipe and hoses
		UIC 648:Sep 2001	Lateral location of brake pipes and cocks
Strength of vehicle structure	4.2.2.4	EN 12663-1:2010	All
Passive safety	4.2.2.5	EN 15227:2008	All except Annex A
Lifting and jacking	4.2.2.6 Annex B	EN 12663-1:2010	Clauses 6.3.2, 6.3.3 and 9.2.3.1
Fixing of devices to car body structure	4.2.2.7	EN 12663-1:2010	Clause 6.5.2
Loading conditions	4.2.2.10	EN 15663:2009	Hypothesis for load conditions
	6.2.2.2.1	EN 14363:2005	Clause 4.5 'vehicle weighting'
<b>Track interaction and gauging</b>	<b>4.2.3</b>		
Kinematic gauge	4.2.3.1	EN 15273-2:2009	Clause A.3.12
		EN 15273-2:2009	Clause B.3
Wheel load	4.2.3.2.2		
		EN 14363:2005	Clause 4.5 'wheel load measurement'
Axle bearing condition monitoring	4.2.3.3.2	EN 15437-1:2009	Clauses 5.1 and 5.2
Safety against derailment running on twisted track	4.2.3.4.1	EN 14363:2005	Clause 4.1
Running dynamic behaviour	4.2.3.4.2 Annex C	EN 14363:2005	Clause 5
		EN 15686:2010	For tilting trains
		EN 13848-1	For track geometric quality
Equivalent conicity	4.2.3.4.3	EN 15302:2008	Calculation method
Design values for new wheel profiles	4.2.3.4.3.1	EN 13674-1:2003/ A1:2007	Rail head profile for modelling equivalent conicity
		EN 13715:2006	Definition of wheel profiles



TSI		Standard	
Characteristics to be assessed		Mandatory reference standard number	Clauses
Element of the rolling stock subsystem	Clause of this TSI		
Structural design of bogie frame	4.2.3.5.1	EN 13749:2005	Clauses 7 and 9.2; Annex C
Mechanical and geometrical characteristics of wheelsets	4.2.3.5.2.1	EN 13260:2009	Clause 3.2.1 and 3.2.2
		EN 13103:2009	Clauses 4, 5 and 6
		EN 13104:2009	Clauses 4, 5 and 6
Mechanical and geometrical characteristics of wheels	4.2.3.5.2.2	EN 13979-1:2003/A1:2009	Clauses 6.2, 6.3, 6.4, 7.2 and 7.3
<b>Braking</b>	<b>4.2.4</b>		
Safety requirements	4.2.4.2.2 6.2.2.2.4	CSM	
Type of brake system	4.2.4.3	EN 14198:2004	Clause 5.4 'UIC brake system'
Braking performance	4.2.4.5	EN 14531-1:2005	Clauses 5.3.1.4, 5.3.3, 5.11.3 and 5.12
	6.2.2.2.4	EN 14531-6:2009	
	6.2.2.2.5		
Wheel slide protection system	4.2.4.6.2	EN 15595:2009	Clause 5
	6.1.2.2.1	EN 15595:2009	Clause 5 or 6.2
	6.2.2.2.6	EN 15595:2009	Clause 6.4
Magnetic track brake	4.2.4.8.2.	UIC 541-06:Jan 1992	Appendix 3
<b>Passenger related items</b>	<b>4.2.5</b>		
<b>Environmental conditions</b>	<b>4.2.6.1</b>		Reference to standards is made only for the definition of zones or substances
Altitude	4.2.6.1.1	EN 50125-1:1999	Clause 4.2
Temperature	4.2.6.1.2	EN 50125-1:1999	Clause 4.3
Humidity	4.2.6.1.3	EN 50125-1:1999	Clause 4.4
Rain	4.2.6.1.4	EN 50125-1:1999	Clause 4.6
Snow, ice and hail	4.2.6.1.5	EN 50125-1:1999	Clause 4.7
Solar radiation	4.2.6.1.6	EN 50125-1:1999	Clause 4.9
Resistance to pollution	4.2.6.1.7	EN 60721-3-5:1997	List of substances
<b>Aerodynamic effects</b>	<b>4.2.6.2</b>		
Slipstream effects on passengers on platform	4.2.6.2.1		
	6.2.2.2.9	EN 14067-4:2005/A1:2009	Clause 7.5.2
Slipstream effects on workers at the track side	4.2.6.2.2		
	6.2.2.2.10	EN 14067-4:2005/A1:2009	Clause 8.5.2
Head pressure pulse	4.2.6.2.3		
	6.2.2.2.11	EN 14067-4:2005/A1:2009	Clauses 5.3, 5.4.3 and 5.5.2





TSI		Standard	
Characteristics to be assessed		Mandatory reference standard number	Clauses
Element of the rolling stock subsystem	Clause of this TSI		
<b>External lights and visible and audible warning devices</b>	<b>4.2.7</b>		
External lights	4.2.7.1.1	EN 15153-1:2007	Clause 5.3.5,
	6.1.2.2.2	EN 15153-1:2007	Clauses 6.1 and 6.2
	4.2.7.1.2	EN 15153-1:2007	Clause 5.4.4
	6.1.2.2.3	EN 15153-1:2007	Clauses 6.1 and 6.2
	4.2.7.1.3	EN 15153-1:2007	Clauses 5.5.3 and 5.5.4
	6.1.2.2.4	EN 15153-1:2007	Clauses 6.1 and 6.2
Horn	4.2.7.2	EN 15153-2:2007	Clauses 4.3.2 and 5
<b>Traction and electrical equipment</b>	<b>4.2.8</b>		
Regenerative brake with energy to the overhead contact line	4.2.8.2.3	EN 50388:2005	Clause 12.1.1
Maximum power and current from the overhead contact line	4.2.8.2.4	EN 50388:2005	Clauses 7.2 and 7.3
	6.2.2.2.12	EN 50388:2005	Clause 14.3
Power factor	4.2.8.2.6		
	6.2.2.2.13	EN 50388:2005	Clause 14.2
System energy disturbances for AC systems	4.2.8.2.7	EN 50388:2005	Clauses 10.1, 10.3, 10.4, Annex D
Working range in height of pantograph	4.2.8.2.9.1	EN 50206-1:2010	Clauses 4.2 and 6.2.3
Pantograph head geometry	4.2.8.2.9.2	EN 50367:2006	Clause 5.2, Annex A.2 figure A.7; Annex B.2 figure B.3
Pantograph current capacity	4.2.8.2.9.3	EN 50206-1:2010	Clause 6.13.2
	6.1.2.2.6	EN 50206-1:2010	Clause 6.13.1
Contact strip material	4.2.8.2.9.4		
	6.1.2.2.7	EN 50405:2006	Clauses 5.2.2, 5.2.3, 5.2.4, 5.2.6 and 5.2.7
Pantograph static contact force	4.2.8.2.9.5		
	6.1.2.2.6	EN 50206-1:2010	Clause 6.3.1
Pantograph dynamic behaviour	6.1.2.2.6	EN 50318:2002	All
		EN 50317:2002	All
Pantograph lowering	4.2.8.2.9.1	EN 50206-1:2010	Clauses 4.7 and 4.8
		EN 50119:2009	Table 2
Electrical protection of the train	4.2.8.2.10	EN 50388:2005	Clause 11
Protection against electrical hazards	4.2.8.4	EN 50153:2002	All

**▼B**

TSI		Standard	
Characteristics to be assessed		Mandatory reference standard number	Clauses
Element of the rolling stock subsystem	Clause of this TSI		
<b>Cab and operation</b>	<b>4.2.9</b>		
Driver's cab	4.2.9.1 Annex E Annex F	UIC 651:July 2002	Appendix E, Appendix F Appendix D, clauses 3.2.1, 3.2.2, 3.3
Windscreen	4.2.9.2	EN 15152:2007	Clauses 4.2.2, 4.2.3, 4.2.4, 4.2.5, 4.2.6, 4.2.7 and 4.2.9
	6.2.2.2.16	EN 15152:2007	Clauses 6.2.1 to 6.2.7
<b>Fire safety and evacuation</b>	<b>4.2.10</b>		
Material requirements	4.2.10.2	TS45545-2:2009	As an alternative to standards specified in the HS RST TSI
		TS45545-1:2009	As an alternative to standards specified in the HS RST TSI
Fire barriers	4.2.10.5	EN 1363-1:1999	Or equivalent safety level
	6.2.2.2.17		
Refuelling equipment	4.2.11.8	UIC 627-2:Jul 1980	Clause 1