

Commission Implementing Decision of 27 June 2013 on the approval of the Valeo Efficient Generation Alternator as an innovative technology for reducing CO₂ emissions from passenger cars pursuant to Regulation (EC) No 443/2009 of the European Parliament and of the Council (Text with EEA relevance) (2013/341/EU) (repealed)

COMMISSION IMPLEMENTING DECISION

of 27 June 2013

on the approval of the Valeo Efficient Generation Alternator as an innovative technology for reducing CO₂ emissions from passenger cars pursuant to Regulation (EC) No 443/2009 of the European Parliament and of the Council

(Text with EEA relevance)

(2013/341/EU) (repealed)

THE EUROPEAN COMMISSION,

Having regard to the Treaty on the Functioning of the European Union,

Having regard to Regulation (EC) No 443/2009 of the European Parliament and of the Council of 23 April 2009 setting emission performance standards for new passenger cars as part of the Community's integrated approach to reduce CO₂ emissions from light-duty vehicles⁽¹⁾, and in particular Article 12(4) thereof,

Whereas:

- (1) The supplier Valeo Equipments Electriques Moteur (the 'Applicant') submitted an application for the approval of the Valeo Efficient Generation (EG) Alternator as an innovative technology on 18 December 2012. The completeness of the application was assessed in accordance with Article 4 of Commission Implementing Regulation (EU) No 725/2011 of 25 July 2011 establishing a procedure for the approval and certification of innovative technologies for reducing CO₂ emissions from passenger cars pursuant to Regulation (EC) No 443/2009 of the European Parliament and of the Council⁽²⁾. The application was found to be complete and the period for the Commission's assessment of the application started on the day following the date of official receipt, i.e. 19 December 2012.
- (2) The application has been assessed in accordance with Article 12 of Regulation (EC) No 443/2009, Implementing Regulation (EU) No 725/2011 and the Technical Guidelines for the preparation of applications for the approval of innovative technologies pursuant to Regulation (EC) No 443/2009 (the Technical Guidelines)⁽³⁾.
- (3) The application refers to the Valeo EG Alternator, which is an alternator with an efficiency of at least 77 per cent as determined in accordance with the VDA approach described in point 5.1.2 in Annex I to the Technical Guidelines. The Applicant's

Status: Point in time view as at 31/01/2020.

Changes to legislation: There are currently no known outstanding effects for the Commission Implementing Decision of 27 June 2013 on the approval of the Valeo Efficient Generation Alternator as an innovative technology for reducing CO₂ emissions from passenger cars pursuant to Regulation (EC) No 443/2009 of the European Parliament and of the Council (Text with EEA relevance) (2013/341/EU) (repealed). (See end of Document for details)

alternator is equipped with synchronous rectification using metal-oxide-semiconductor field-effect transistors thereby ensuring a high level of efficiency.

- (4) The Commission finds that the information provided in the application demonstrates that the conditions and criteria referred to in Article 12 of Regulation (EC) No 443/2009 and in Articles 2 and 4 of Implementing Regulation (EU) No 725/2011 have been met.
- (5) The Applicant has demonstrated that a high efficiency alternator of the kind described in this application will only be available on the EU market as from 2013 and that consequently the market penetration in 2009 of this type of alternators was below the 3 per cent threshold specified in Article 2(2)(a) of Implementing Regulation (EU) No 725/2011. This claim is also supported by the accompanying verification report. On that basis, the Commission finds that the high efficiency alternator provided by the Applicant should be considered meeting the eligibility criterion set out in Article 2(2) (a) of Implementing Regulation (EU) No 725/2011.
- (6) In order to determine the CO₂ savings that the innovative technology will deliver when fitted to a vehicle, it is necessary to define the baseline vehicle against which the efficiency of the vehicle equipped with the innovative technology should be compared as provided for in Articles 5 and 8 of Implementing Regulation (EU) No 725/2011. The Commission finds that it is appropriate to consider an alternator with 67 % efficiency as an appropriate baseline technology in the case the innovative technology is fitted on a new vehicle type. Where the Valeo EG Alternator is fitted to an existing vehicle type, the baseline technology should be the alternator of the most recent version of that type placed on the market.
- (7) The Applicant has provided a comprehensive methodology for testing the CO₂ reductions. It includes formulae that are consistent with the formulae described in the Technical Guidelines for the simplified approach with regard to efficient alternators. The Commission considers that the testing methodology will provide testing results that are verifiable, repeatable and comparable and that it is capable of demonstrating in a realistic manner the CO₂ emissions benefits of the innovative technology with strong statistical significance in accordance with Article 6 of Implementing Regulation (EU) No 725/2011.
- (8) Against that background the Commission finds that the Applicant has demonstrated satisfactorily that the emission reduction achieved by the innovative technology is at least 1 g CO₂/km.
- (9) The Commission notes that the savings of the innovative technology may be partially demonstrated on the standard test cycle, and the final total savings to be certified should therefore be determined in accordance with the second subparagraph of Article 8(2) of Implementing Regulation (EU) No 725/2011.
- (10) The Commission finds that the verification report has been prepared by UTAC which is an independent and certified body and that the report supports the findings set out in the application.
- (11) Against that background, the Commission finds that no objections should be raised as regards the approval of the innovative technology in question.

Status: Point in time view as at 31/01/2020.

Changes to legislation: There are currently no known outstanding effects for the Commission Implementing Decision of 27 June 2013 on the approval of the Valeo Efficient Generation Alternator as an innovative technology for reducing CO₂ emissions from passenger cars pursuant to Regulation (EC) No 443/2009 of the European Parliament and of the Council (Text with EEA relevance) (2013/341/EU) (repealed). (See end of Document for details)

- (12) Any manufacturer wishing to benefit from a reduction of its average specific CO₂ emissions for the purpose of meeting its specific emissions target by means of the CO₂ savings from the use of the innovative technology approved by this Decision, should in accordance with Article 11(1) of Implementing Regulation (EU) No 725/2011, refer to this Decision in its application for an EC type-approval certificate for the vehicles concerned,

HAS ADOPTED THIS DECISION:

Article 1

1 The Valeo Efficient Generation Alternator having an efficiency of at least 77 per cent and intended for use in M1 vehicles is approved as an innovative technology within the meaning of Article 12 of Regulation (EC) No 443/2009.

2 The CO₂ emissions reduction from the use of the alternator referred to in paragraph 1 shall be determined using the methodology set out in the Annex.

3 In accordance with the second subparagraph of Article 11(2) of Implementing Regulation (EU) No 725/2011, the CO₂ emission reduction determined in accordance with paragraph 2 of this Article, may only be certified and entered into the certificate of conformity and relevant type approval documentation specified in Annexes I, VIII and IX to Directive 2007/46/EC of the European Parliament and of the Council⁽⁴⁾ where the reductions are on or above the threshold specified in Article 9(1) of Implementing Regulation (EU) No 725/2011.

Article 2

This Decision shall enter into force on the 20th day following that of its publication in the *Official Journal of the European Union*.

Status: Point in time view as at 31/01/2020.

Changes to legislation: There are currently no known outstanding effects for the Commission Implementing Decision of 27 June 2013 on the approval of the Valeo Efficient Generation Alternator as an innovative technology for reducing CO₂ emissions from passenger cars pursuant to Regulation (EC) No 443/2009 of the European Parliament and of the Council (Text with EEA relevance) (2013/341/EU) (repealed). (See end of Document for details)

ANNEX

Methodology for determining the reduction in CO₂ emissions due to the use of the Valeo Efficient Generation Alternator in an M1 vehicle

1. Introduction

In order to determine the CO₂ reductions that can be attributed to the use of the Valeo EG Alternator in an M1 vehicle, it is necessary to establish the following:

- (a) the testing procedure to be followed for determining the efficiency of the alternator;
- (b) the setting of the test bench;
- (c) the formulae for calculating the standard deviation;
- (d) the determination of the CO₂ savings for the certification by type approval authorities.

2. Testing procedure

The efficiency of the alternator must be determined by doing measurements at different speeds: 1 800, 3 000, 6 000, 10 000 revolutions per minute. At each speed the alternator is charged at 50 % of the maximum load. For calculating the efficiency, a time distribution is to be 25 %, 40 %, 25 %, 10 % for respectively 1 800, 3 000, 6 000, 10 000 revolutions per minute (see the VDA approach as described in point 5.1.2 in Annex I to the Technical Guidelines).

This leads to the following formula (1):

$$\Delta\eta_A = \sqrt{\left(0,25 * S_{1\,800}\right)^2 + \left(0,40 * S_{3\,000}\right)^2 + \left(0,25 * S_{6\,000}\right)^2 + \left(0,1 * S_{10\,000}\right)^2}$$

]

With:

- η_A is the efficiency of the alternator;
- ($\eta @1\,800\text{ rpm } @0,5 \cdot I_N$) is the efficiency of the alternator at a speed of 1 800 rpm and at a load of 50 %;
- ($\eta @3\,000\text{ rpm } @0,5 \cdot I_N$) is the efficiency of the alternator at a speed of 3 000 rpm and at a load of 50 %;
- ($\eta @6\,000\text{ rpm } @0,5 \cdot I_N$) is the efficiency of the alternator at a speed of 6 000 rpm and at a load of 50 %;
- ($\eta @10\,000\text{ rpm } @0,5 \cdot I_N$) is the efficiency of the alternator at a speed of 10 000 rpm and at a load of 50 %;
- I_N = Current (A)

The set-up of the test bench and the testing procedure is to fulfil the precision requirements specified in ISO 8854:2012⁽⁵⁾.

3. Test bench

The test bench is to be a ‘direct drive’ alternator test bench. The alternator is to be directly linked to the torque meter and to the shaft of the drive train. The alternator is to be loaded with a battery and an electronic load. See the test bench configuration in figure 1.

Figure 1

Status: Point in time view as at 31/01/2020.

Changes to legislation: There are currently no known outstanding effects for the Commission Implementing Decision of 27 June 2013 on the approval of the Valeo Efficient Generation Alternator as an innovative technology for reducing CO₂ emissions from passenger cars pursuant to Regulation (EC) No 443/2009 of the European Parliament and of the Council (Text with EEA relevance) (2013/341/EU) (repealed). (See end of Document for details)

The test bench configuration

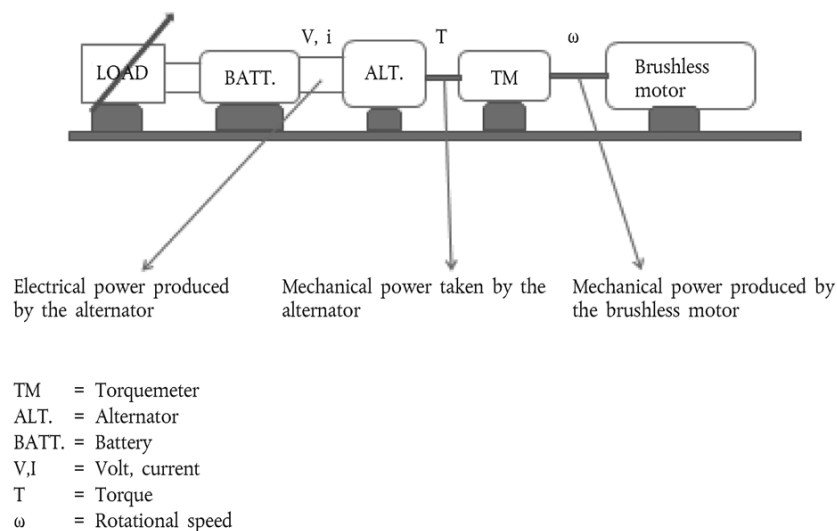

In figure 1 an overview of the test bench configuration is given. The alternator transfers the mechanical power of the brushless motor into electrical power. The brushless motor generates an amount of power which is defined by the torque (Nm) and by the rotational speed (rad.s^{-1}). The torque and the speed are to be measured by the torque meter.

The alternator produces power to overcome the load which is connected to the alternator. This amount of power is equal to the alternator voltage (V) times the alternator current (I).

The efficiency of the alternator is to be defined as the electric power (output of the alternator) divided by the mechanical power (output of the torquemeter).

$$\text{Formula (2)} \quad : \quad \eta_A = (V * i) / (T * \omega)$$

Where:

η_A = Efficiency of the alternator;
V = Voltage (V);
I = Current (A);
T = Torque (Nm);
 ω = Rotational speed of the alternator (rad. s^{-1})

4. Measuring the torque and calculating the efficiency of the alternator

The tests are to be carried out in accordance with the ISO 8854:2012.

The load is to be installed at 50 % of the current which is guaranteed by the alternator at 25 °C and a rotor speed of 6 000 rpm, e.g. if the alternator is a 180 A class alternator (at 25 °C and 6 000 rpm), the load is installed at 90 A.

For each speed the voltage and the output current of the alternator are to be kept constant, the voltage at 14,3 V and the current for a 180 A-alternator at 90 A, i.e. for each speed the torque is to be measured by means of the test bench (see figure 1) and the efficiency is to be calculated by means of formula (2).

This test is to provide the efficiencies of the alternator at 4 different speeds in revolutions per minute (rpm):

Status: Point in time view as at 31/01/2020.

Changes to legislation: There are currently no known outstanding effects for the Commission Implementing Decision of 27 June 2013 on the approval of the Valeo Efficient Generation Alternator as an innovative technology for reducing CO₂ emissions from passenger cars pursuant to Regulation (EC) No 443/2009 of the European Parliament and of the Council (Text with EEA relevance) (2013/341/EU) (repealed). (See end of Document for details)

- At a speed of 1 800 rpm;
- At a speed of 3 000 rpm;
- At a speed of 6 000 rpm;
- At a speed of 10 000 rpm.

The average efficiency of the alternator is to be calculated by means of formula (1).

5. Standard deviation of the arithmetic mean value of the efficiency of the alternator

Statistical errors in the outcomes of the testing methodology caused by the measurements are to be quantified. The format of the error value is to be a standard deviation being equivalent to a two-sided confidence interval of 84 % (see formula (3)).

Formula (3) :
$$s_{\bar{x}} = \sqrt{\frac{\sum_{i=1}^n (x_i - \bar{x})^2}{n(n-1)}}$$

Where:

- $s_{\bar{x}}$: standard deviation of arithmetic mean;
- x_i : measurement value;
- \bar{x} : arithmetic mean;
- n : number of measurements

All measurements are to be performed consecutively at least five (5) times. For each speed the standard deviation is calculated.

The standard deviation of the efficiency value of the alternator ($\Delta\eta_A$) is calculated by the following formula:

Formula (4) :
$$\Delta\eta_A = \sqrt{(0,25 * (S_{1800})^2 + 0,40 * (S_{3000})^2 + 0,25 * (S_{6000})^2 + 0,1 * (S_{10000})^2)}$$

Where the values 0,25, 0,40, 0,25, and 0,1 are the same weighting values as in formula (2) and $S_{1\ 800}$, $S_{3\ 000}$, $S_{6\ 000}$, and $S_{10\ 000}$ are the standard deviations calculated with formula (3).

6. Error in the CO₂ savings due to the standard deviation (propagation law)

The standard deviation of the efficiency value of the alternator ($\Delta\eta_A$), leads to an error in the CO₂ savings. This error is to be calculated by means of the following formula⁽⁶⁾:

Formula (5) :
$$\Delta CO_2 = (P_{m-RW} - P_{m-TA}) \times (1 / \eta_{A-EI}^2) \times \Delta\eta_A \times (V_{Pe} \times CF_p / v)$$

Where:

- ΔCO_2 = error in CO₂ savings (g CO₂/km);
- P_{RW} = 750 W;
- P_{TA} = 350 W;
- η_{A-EI} = Efficiency of the high efficient alternator;
- $\Delta\eta_A$ = Standard deviation of the efficiency of the alternator (result of equation in Formula (4));
- V_{Pe} = Willans' factors (l/kWh);
- CF = Conversion factors (g CO₂/l);
- v = mean driving speed of the NEDC (km/h)

7. Calculation of the accountable share of the mechanical power saving

Status: Point in time view as at 31/01/2020.

Changes to legislation: There are currently no known outstanding effects for the Commission Implementing Decision of 27 June 2013 on the approval of the Valeo Efficient Generation Alternator as an innovative technology for reducing CO₂ emissions from passenger cars pursuant to Regulation (EC) No 443/2009 of the European Parliament and of the Council (Text with EEA relevance) (2013/341/EU) (repealed). (See end of Document for details)

The high efficient alternator leads to the saved mechanical power which is to be calculated in two steps. In the first step the saved mechanical power is to be calculated under ‘real world’ conditions. The second step is to calculate the saved mechanical power under type approval conditions. Subtracting these 2 mechanical power savings is to result in the accountable share of the saved mechanical power.

The saved mechanical power under ‘real world’ conditions is to be calculated with formula (6).

$$\text{Formula (6)} \quad : \quad \Delta P_{m-RW} = (P_{RW} / \eta_A) - (P_{RW} / \eta_{A-EI})$$

Where:

ΔP_{m-RW}	= Saved mechanical power under real world conditions (W);
P_{RW}	= Electric power under real world conditions, which is 750 W;
η_A	= Efficiency of the baseline alternator;
η_{A-EI}	= Efficiency of the high efficient alternator

The saved mechanical power under type-approval conditions is to be calculated with formula (7).

$$\text{Formula (7)} \quad : \quad \Delta P_{m-TA} = (P_{TA} / \eta_A) - (P_{TA} / \eta_{A-EI})$$

Where:

ΔP_{m-TA}	= Saved mechanical power under type approval conditions (W);
P_{TA}	= Electric power under type approval conditions, which is 350 W;
η_A	= Efficiency of the baseline alternator;
η_{A-EI}	= Efficiency of the high efficient alternator

The accountable share of saved mechanical power is calculated with formula (8).

$$\text{Formula (8)} \quad : \quad \Delta P_m = \Delta P_{m-RW} - \Delta P_{m-TA}$$

Where:

ΔP_m	= Accountable share of saved mechanical power (W);
ΔP_{m-RW}	= Saved mechanical power under real world conditions (W);
ΔP_{m-TA}	= Saved mechanical power under type approval conditions (W);

8. Formula to calculate the CO₂ savings

The CO₂ savings are to be calculated with the following formula:

$$\text{Formula (9)} \quad : \quad C_{CO_2} = \Delta P_m \times V_{Pe} \times CF / v$$

Where:

C_{CO_2}	= CO ₂ savings (g CO ₂ /km);
ΔP_m	= Accountable share of saved mechanical power as per formula (8) (W);
V_{Pe}	= Willans’ factors (l/kWh);
CF	= Conversion factors (g CO ₂ /l)
v	= mean driving speed of the NEDC (km/h)

For the Willans’ factors the data in table 1 is to be used:

TABLE 1

Willans’ factors

Status: Point in time view as at 31/01/2020.

Changes to legislation: There are currently no known outstanding effects for the Commission Implementing Decision of 27 June 2013 on the approval of the Valeo Efficient Generation Alternator as an innovative technology for reducing CO₂ emissions from passenger cars pursuant to Regulation (EC) No 443/2009 of the European Parliament and of the Council (Text with EEA relevance) (2013/341/EU) (repealed). (See end of Document for details)

Type of engine	Consumption of effective power V_{Pe} [l/kWh]
Petrol (V_{Pe-P})	0,264
Petro Turbo	0,28
Diesel (V_{Pe-D})	0,22

For the conversion factors the data in table 2 is to be used:

TABLE 2

Conversion factors

Type of fuel	Conversion factor (l/100 km) → (g CO ₂ /km)[100 g/l]
Petrol	23,3 (= 2 330 g CO ₂ /l)
Petro Turbo	23,3 (= 2 330 g CO ₂ /l)
Diesel	26,4 (= 2 640 g CO ₂ /l)

The mean driving speed of the NEDC is: $v = 33,58$ km/h

9. Statistical Significance

It has to be demonstrated for each type, variant and version of a vehicle fitted with the Valeo EG Alternator that the error in the CO₂ savings calculated with Formula 5 is not greater than the difference between the total CO₂ savings and the minimum savings threshold specified in Article 9(1) of Implementing Regulation (EU) No 725/2011 (see Formula (7)).

$$\text{Formula (10)} \quad : \quad MT < C_{CO_2} - \Delta \bar{C}_{CO_2}$$

Where:

- MT = minimum threshold (g CO₂/km);
 C_{CO_2} = total CO₂ saving, (g CO₂/km);
 $\Delta \bar{C}_{CO_2}$ = error in the CO₂ savings (g CO₂/km)

10. The high efficient alternator to be implemented in vehicles

For determining the CO₂ savings to be certified due to the use of the Valeo EG Alternator by the type approval authority in accordance with Article 12 of Implementing Regulation (EU) No 725/2011, the manufacturer of the M1 vehicle in which the alternator is fitted has to designate in accordance with Article 5 of that Regulation, an eco-innovation vehicle fitted with the Valeo (EG) Alternator and either of the following baseline vehicles:

- (a) if the eco-innovation is fitted to a new vehicle type which will be submitted to a new type approval, the baseline vehicle is to be the same as the new vehicle type in all respects except with regard to the alternator which is to be an alternator with an efficiency of 67 %, or
- (b) if the eco-innovation is fitted to an existing vehicle version for which the type approval will be extended following the replacement of the existing alternator by the eco-innovation, the base vehicle is to be the same as the eco-innovation vehicle in all

Status: Point in time view as at 31/01/2020.

Changes to legislation: There are currently no known outstanding effects for the Commission Implementing Decision of 27 June 2013 on the approval of the Valeo Efficient Generation Alternator as an innovative technology for reducing CO₂ emissions from passenger cars pursuant to Regulation (EC) No 443/2009 of the European Parliament and of the Council (Text with EEA relevance) (2013/341/EU) (repealed). (See end of Document for details)

respects except with regard to the alternator which is to be the alternator of the existing vehicle version.

The type approval authority is to certify the CO₂ savings based on measurements of the base vehicle and eco-innovation vehicle in accordance with Article 8(1) and the second subparagraph of Article 8(2) of Implementing Regulation (EU) No 725/2011 using the test methodology set out in this Annex. Where the CO₂ emission savings are below the threshold specified in Article 9(1), the second subparagraph of Article 11(2) of Implementing Regulation (EU) No 725/2011 shall apply.

11. **Eco-innovation code to be entered into type approval documentation**

For the purposes of determining the general eco-innovation code to be used in the relevant type approval documents in accordance with Annexes I, VIII and IX to Directive 2007/46/EC, the individual code to be used for the innovative technology approved through this Decision shall be '2'.

E.g. the code of the eco-innovation in the case of eco-innovation savings certified by the German type approval authority shall be 'e1 2'.

Status: Point in time view as at 31/01/2020.

Changes to legislation: There are currently no known outstanding effects for the Commission Implementing Decision of 27 June 2013 on the approval of the Valeo Efficient Generation Alternator as an innovative technology for reducing CO2 emissions from passenger cars pursuant to Regulation (EC) No 443/2009 of the European Parliament and of the Council (Text with EEA relevance) (2013/341/EU) (repealed). (See end of Document for details)

- (1) [OJ L 140, 5.6.2009, p. 1.](#)
- (2) [OJ L 194, 26.7.2011, p. 19.](#)
- (3) http://ec.europa.eu/clima/policies/transport/vehicles/cars/docs/guidelines_en.pdf
- (4) [OJ L 263, 9.10.2007, p. 1.](#)
- (5) ISO 8854. Road vehicles — Alternators with regulators — Test methods and general requirements. Reference number ISO 8854:2012(E).
- (6) This formula (5) can be derived from the error propagation law which is explained in the Technical Guidelines (par. 4.2.1).

Status:

Point in time view as at 31/01/2020.

Changes to legislation:

There are currently no known outstanding effects for the Commission Implementing Decision of 27 June 2013 on the approval of the Valeo Efficient Generation Alternator as an innovative technology for reducing CO2 emissions from passenger cars pursuant to Regulation (EC) No 443/2009 of the European Parliament and of the Council (Text with EEA relevance) (2013/341/EU) (repealed).