

Commission Implementing Decision (EU) 2020/1222 of 24 August 2020 on the approval of efficient vehicle exterior lighting using light emitting diodes as an innovative technology for reducing CO<sub>2</sub> emissions from internal combustion engine powered light commercial vehicles with regard to NEDC conditions pursuant to Regulation (EU) 2019/631 of the European Parliament and of the Council (Text with EEA relevance)

COMMISSION IMPLEMENTING DECISION (EU) 2020/1222

of 24 August 2020

on the approval of efficient vehicle exterior lighting using light emitting diodes as an innovative technology for reducing CO<sub>2</sub> emissions from internal combustion engine powered light commercial vehicles with regard to NEDC conditions pursuant to Regulation (EU) 2019/631 of the European Parliament and of the Council

(Text with EEA relevance)

THE EUROPEAN COMMISSION,

Having regard to the Treaty on the Functioning of the European Union,

Having regard to Regulation (EU) 2019/631 of the European Parliament and of the Council of 17 April 2019 setting CO<sub>2</sub> emission performance standards for new passenger cars and for new light commercial vehicles, and repealing Regulations (EC) No 443/2009 and (EU) No 510/2011<sup>(1)</sup>, and in particular Article 11(4) thereof,

Whereas:

- (1) On 19 December 2019, the manufacturers Toyota Motor Europe, Opel Automobile GmbH–PSA, FCA Italy S.p.A., Automobiles Citroën, Automobiles Peugeot, PSA Automobiles SA, Audi AG, Ford-Werke GmbH, Jaguar Land Rover Ltd., Hyundai Motor Europe Technical Center GmbH, Škoda Auto a.s., BMW AG, Renault SA, Honda Motor Europe Ltd, Volkswagen AG and Volkswagen AG Nutzfahrzeuge submitted a joint application (‘the application’) for the approval, in accordance with Article 11 of Regulation (EU) 2019/631, of efficient vehicle exterior lighting using light emitting diodes (‘efficient exterior LED light’) as an innovative technology for reducing CO<sub>2</sub> emissions from internal combustion engine powered light commercial vehicles capable of running on petrol, diesel and certain alternative fuels.
- (2) The application has been assessed in accordance with Article 11 of Regulation (EU) 2019/631, Commission Implementing Regulation (EU) No 427/2014<sup>(2)</sup> as well as with the Technical Guidelines for the preparation of applications for the approval of innovative technologies pursuant to Regulation (EC) No 443/2009 of the European Parliament and of the Council<sup>(3)</sup> (July 2018 version)<sup>(4)</sup>. In accordance with Article 11(3) of Regulation (EU) 2019/631, the application was accompanied by a verification report undertaken by an independent and certified body.

---

*Changes to legislation:* There are outstanding changes not yet made to Commission Implementing Decision (EU) 2020/1222. Any changes that have already been made to the legislation appear in the content and are referenced with annotations. (See end of Document for details) [View outstanding changes](#)

---

- (3) The application refers to CO<sub>2</sub> emission savings that cannot be demonstrated by measurements performed in accordance with the New European Driving Cycle ('NEDC test') set out in Commission Regulation (EC) No 692/2008<sup>(5)</sup>.
- (4) The use of light emitting diodes for improving the efficiency of exterior vehicle lighting has already been approved for certain exterior lights of passenger cars by Commission Implementing Decisions 2014/128/EU<sup>(6)</sup>, (EU) 2015/206<sup>(7)</sup>, (EU) 2016/160<sup>(8)</sup> and (EU) 2016/587<sup>(9)</sup> (jointly referred to as 'past approval Implementing Decisions') as an innovative technology capable of reducing CO<sub>2</sub> emissions in a way that is not covered by the measurements performed as part of the NEDC test.
- (5) Based on the experience gained from the assessment of the applications in the framework of the past approval Implementing Decisions as well as on the reports and information provided with the application, it has been satisfactorily and conclusively demonstrated that an efficient exterior LED light or appropriate combinations thereof meet the eligibility criteria referred to in Article 11 of Regulation (EU) 2019/631 and Implementing Regulation (EU) No 427/2014 and provide a reduction in CO<sub>2</sub> emissions of at least 1 g CO<sub>2</sub>/km as compared to the same set of baseline exterior lights.
- (6) In addition to the exterior vehicle lighting for which the use of efficient LED lights has already been approved in the past approval Implementing Decisions, the application also refers to the use of efficient exterior LED lights in cornering, static bending, end-outline marker and side marker lights. As those lights are not turned on during the measurements performed as part of the NEDC test, it is appropriate to approve the use of efficient exterior LED lights also in those lights.
- (7) The application sets out a methodology for determining the CO<sub>2</sub> savings from the use of efficient exterior LED lights in a range of vehicle lights for use in light commercial vehicles powered by internal combustion engines capable of running on petrol, diesel, liquefied petroleum gas (LPG), compressed natural gas (CNG) or E85.
- (8) In view of the limited availability of E85 on the Union market as a whole, it is not considered justified to distinguish this fuel from petrol for the purpose of the testing methodology.
- (9) The applicants have provided studies supporting that the usage patterns of light commercial vehicles and those of passenger cars, with regard to the use of exterior vehicle lighting, are sufficiently similar to allow the same methodology to be applied for light commercial vehicles as the one set out in the past Implementing Decisions.
- (10) However, with regard to the cornering lamps, the static bending lamps, end-outline marker lights and side marker lights, which have not been covered by the past Implementing Decisions, the applicants have proposed to include specific usage factors and power consumption values in the testing methodology. As the usage factors and power consumption values proposed by the applicants for those lights result in values that can be considered conservative, it is appropriate to add those factors and values to the testing methodology.

---

**Changes to legislation:** There are outstanding changes not yet made to Commission Implementing Decision (EU) 2020/1222. Any changes that have already been made to the legislation appear in the content and are referenced with annotations. (See end of Document for details) [View outstanding changes](#)

---

- (11) The methodology should also be complemented to ensure that the presence of adaptive front lighting systems (AFS) used in low beam lights can be taken into account.
- (12) Taking into account those additions, the testing methodology should be considered appropriate for determining the CO<sub>2</sub> savings from the use of the innovative technology in light commercial vehicles.
- (13) Manufacturers should have the possibility to apply to a type-approval authority for the certification of CO<sub>2</sub> savings from the use of efficient exterior LED lights where the conditions laid down in this Decision are met. Manufacturers should for that purpose ensure that the application for certification is accompanied by a verification report from an independent and certified body confirming that the innovative technology complies with the conditions laid down in this Decision and that the savings have been determined in accordance with the testing methodology set out in the Annex of this Decision.
- (14) In order to facilitate a wider deployment of the innovative technology in new vehicles, a manufacturer should also have the possibility to submit a single application for the certification of the CO<sub>2</sub> savings from several efficient exterior LED lights by a single certification application. It is, however, appropriate to ensure that where this possibility is used a mechanism is applied that incentivises the deployment of only those efficient exterior LED lights that offer the highest efficiency.
- (15) It is the responsibility of the type-approval authority to verify thoroughly that the conditions for certifying the CO<sub>2</sub> savings from the use of an innovative technology as specified in this Decision are met. Where the certification is granted, the responsible type-approval authority should ensure that all elements considered for the certification are recorded in a test report and kept together with the verification report and that this information is made available to the Commission on request.
- (16) For the purpose of determining the general eco-innovation code to be used in the relevant type-approval documents in accordance with Annexes I, VIII and IX to Directive 2007/46/EC of the European Parliament and of the Council<sup>(10)</sup>, it is necessary to attribute an individual code to the innovative technology.
- (17) From 2021, manufacturers' compliance with their specific CO<sub>2</sub> emission targets is to be established on the basis of the CO<sub>2</sub> emissions determined in accordance with the Worldwide Harmonised Light Vehicle Test Procedure (WLTP) set out in Commission Regulation (EU) 2017/1151<sup>(11)</sup>. CO<sub>2</sub> savings from the innovative technology certified by reference to this Decision may therefore be taken into account for the calculation of manufacturers' average specific CO<sub>2</sub> emissions only for the calendar year 2020,

HAS ADOPTED THIS DECISION:

#### *Article 1*

#### **Innovative technology**

The use of efficient light emitting diodes in vehicle exterior lighting is approved as an innovative technology within the meaning of Article 11 of Regulation (EU) 2019/631

---

*Changes to legislation:* There are outstanding changes not yet made to Commission Implementing Decision (EU) 2020/1222. Any changes that have already been made to the legislation appear in the content and are referenced with annotations. (See end of Document for details) [View outstanding changes](#)

---

for use in light commercial vehicles powered by internal combustion engines that are capable of running on petrol, diesel, liquefied petroleum gas (LPG), compressed natural gas (CNG) or E85, or a combination of those fuels, where it is used in one or several of the following exterior vehicle lights:

- (a) Low beam headlamp (including Adaptive Front Lighting system);
- (b) High beam headlamp;
- (c) Front position lamp;
- (d) Front fog lamp;
- (e) Rear fog lamp;
- (f) Front turn signal lamp;
- (g) Rear turn signal lamp;
- (h) License plate lamp;
- (i) Reversing lamp;
- (j) Cornering lamp;
- (k) Static Bending light;
- (l) End-Outline marker lights;
- (m) Side markers lights.

## *Article 2*

### **Application for certification of CO<sub>2</sub> savings**

1 A manufacturer may apply to a type-approval authority for certification of the CO<sub>2</sub> savings from the use of one or several efficient exterior LED light by reference to this Decision.

2 The manufacturer shall ensure that the application for the certification is accompanied by a verification report from an independent and certified body confirming that the conditions set out in Article 1 have been met.

3 Where the savings have been certified in accordance with Article 3, the manufacturer shall ensure that the certified CO<sub>2</sub> savings and the eco-innovation code referred to in Article 4(1) are recorded in the certificate of conformity of the vehicles concerned.

## *Article 3*

### **Certification of CO<sub>2</sub> savings**

1 The type-approval authority shall ensure that CO<sub>2</sub> savings achieved from the use of the innovative technology have been determined using the methodology set out in the Annex.

2 Where a manufacturer applies for the certification of the CO<sub>2</sub> savings from more than one efficient exterior LED light referred to in Article 1 in relation to one vehicle version, the type approval authority shall determine which of the efficient exterior LED lighting tested delivers

---

*Changes to legislation:* There are outstanding changes not yet made to Commission Implementing Decision (EU) 2020/1222. Any changes that have already been made to the legislation appear in the content and are referenced with annotations. (See end of Document for details) [View outstanding changes](#)

---

the lowest CO<sub>2</sub> savings, and record the lowest value in the relevant type approval documentation. That value shall be used for the purpose of paragraph 4.

3 Where the innovative technology is fitted in a bi-fuel or flex-fuel vehicle, the approval authority shall record the CO<sub>2</sub> savings as follows:

- a for bi-fuel vehicles using petrol and gaseous fuels, the CO<sub>2</sub> savings value with regard to LPG or CNG fuels;
- b for flex-fuel vehicles using petrol and E85, the CO<sub>2</sub> savings value with regard to petrol.

4 The type approval authority shall record the certified CO<sub>2</sub> savings determined in accordance with paragraphs 1 and 2, and the eco-innovation code referred to in Article 4(1) in the relevant type-approval documentation.

5 The type-approval authority shall record all the elements considered for the certification in a test report and keep that together with the verification report referred to in Article 2(2), and shall make that information available to the Commission on request.

6 The type-approval authority shall only certify CO<sub>2</sub> savings, if it finds that the innovative technology complies with the conditions set out in Article 1, and if the CO<sub>2</sub> savings achieved are 1 g CO<sub>2</sub>/km or higher, as specified in Article 9(1)(a) of Implementing Regulation (EU) No 427/2014.

#### *Article 4*

##### **Eco-innovation code**

1 The innovative technology approved by this Decision is attributed with the eco-innovation code 34.

2 The certified CO<sub>2</sub> savings recorded by reference to that eco-innovation code may only be taken into account for the calculation of the average specific emissions of manufacturers for the calendar year 2020.

#### *Article 5*

##### **Entry into force**

This Decision shall enter into force on the twentieth day following that of its publication in the *Official Journal of the European Union*.

Done at Brussels, 24 August 2020.

*For the Commission*

*The President*

Ursula VON DER LEYEN

---

**Changes to legislation:** There are outstanding changes not yet made to Commission Implementing Decision (EU) 2020/1222. Any changes that have already been made to the legislation appear in the content and are referenced with annotations. (See end of Document for details) View outstanding changes

---

## ANNEX

### Methodology to determine the CO<sub>2</sub> savings of Efficient Exterior LED Lighting under NEDC for use in light commercial vehicles

#### 1. INTRODUCTION

This Annex sets out the methodology to determine the CO<sub>2</sub> (carbon dioxide) emission savings to be attributed to the use of efficient vehicle exterior lighting using one or an appropriate combination of LED lights listed in Article 1, for use in light commercial N<sub>1</sub> vehicles powered by an internal combustion engine.

#### 2. TESTING CONDITIONS

The testing conditions shall fulfil the requirements of UN/ECE Regulations Nos 4 <sup>(1)</sup>, 6 <sup>(2)</sup>, 7 <sup>(3)</sup>, 19 <sup>(4)</sup>, 23 <sup>(5)</sup>, 38 <sup>(6)</sup>, 48 <sup>(7)</sup>, 91 <sup>(8)</sup> 100 <sup>(9)</sup>, 112 <sup>(10)</sup>, 119 <sup>(11)</sup> and 123 <sup>(12)</sup><sup>(12)</sup>. The power consumption shall be determined in accordance with point 6.1.4 of UN/ECE Regulation No 112, and points 3.2.1 and 3.2.2 of Annex 10 to that Regulation.

For the low beam adaptive front lighting system (AFS) falling within at least two of the Classes C, E, V or W as defined in Regulation UN/ECE No 123 (see Table 1), the power consumption measurements shall be done at the LED intensity of each class (P<sub>k</sub>), where k corresponds to each class specified at Table 1 as defined in Regulation UN/ECE 123.

If it is agreed with the technical service that Class C is the representative/average LED intensity for the vehicle application, power consumption measurements shall be done in the same way as for any other exterior LED light included in the combination.

TABLE 1

#### Classes of Low beam AFS

Class	See point 1.3 and footnote 2 of UN/ECE Regulation 123	% LED Intensity	Activation Mode <sup>a</sup>
C	Base Passing Beam (Country)	100	50 km/h < speed < 100 km/h Or when no mode of another passing beam class is activated (V, W, E)
V	Town	85	Speed < 50 km/h
E	Motorway	110	Speed > 100 km/h
W	Adverse Conditions	90	Windshield wiper active > 2 minutes

<sup>a</sup> Activation speeds shall be checked for each vehicle application in accordance with UN/ECE Regulation No 48 section 6, chapter 6.22, paragraphs 6.22.7.4.1 (class C), 6.22.7.4.2 (class V), 6.22.7.4.3 (class E), 6.22.7.4.4 (class W).

#### 2.1. Test equipment

The following test equipment shall be used:

---

**Changes to legislation:** There are outstanding changes not yet made to Commission Implementing Decision (EU) 2020/1222. Any changes that have already been made to the legislation appear in the content and are referenced with annotations. (See end of Document for details) [View outstanding changes](#)

---

- a power supply unit (i.e. variable voltage supplier);
- two digital multimeters, one for measuring the DC-current, and the other for measuring the DC-voltage.

Figure 1 shows a possible test set-up, with the DC-voltage meter integrated in the power supply unit.

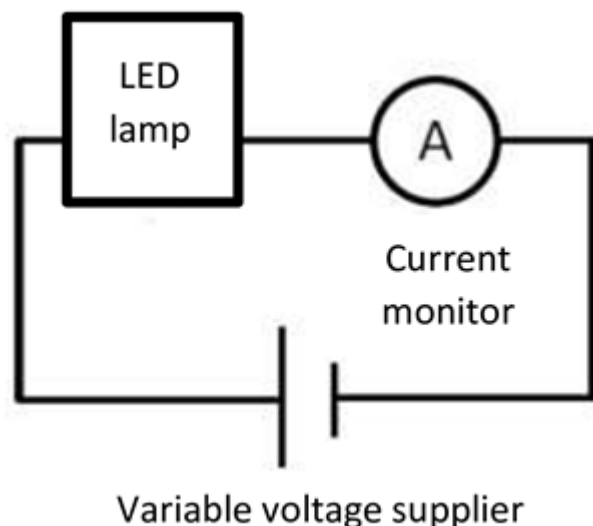

## 2.2. Determination of the power savings

### 2.2.1. Measurement of the power consumption

For each efficient exterior LED light included in a combination, the measurement of the current shall be performed at a voltage of 13,2 V. LED module(s) operated by an electronic light source control gear, shall be measured as specified by the applicant.

The manufacturer may request that additional measurements of the current shall be performed at other voltages, where the necessity to do so can be demonstrated on the basis of verified documentation.

In any case the measurements (n) shall be performed for each voltage at least five times consecutively. The applied voltage and the measured current shall be recorded in four decimals.

The power consumption shall be determined by multiplying the voltage with the measured current. The average of the power consumption for each efficient exterior LED light ( $\overline{P_{EI_i}}$ ) [W] shall be calculated as set out in Formula 1 with four decimals to be taken into account in the calculations. When a stepper motor or electronic controller is used for the supply of the electricity to the LED lamps, then the electric load of this component is to be excluded from the measurement.

*Formula 1*

$$\overline{P_{EI_i}} = \frac{\sum_{j=1}^n (V_{EI_{ij}} \cdot I_{EI_{ij}})}{n}$$

where,

**Changes to legislation:** There are outstanding changes not yet made to Commission Implementing Decision (EU) 2020/1222. Any changes that have already been made to the legislation appear in the content and are referenced with annotations. (See end of Document for details) View outstanding changes

$V_{EI_{ij}}$	is the tested voltage of each LED vehicle light i
$I_{EI_{ij}}$	is the measured current of each LED vehicle light i
n	is the number of measurements of the sample
j	refers to an individual measurement of power consumption

In case of low beam AFS, the power consumption ( $P_{EI_{AFS}}$ ) [W] shall be calculated as the average of the LED power consumption for each class k, weighted according to the NEDC time share per speed range, in accordance with Formula 2.

Formula 2

$$P_{EI_{AFS}} = \sum_{k=1}^K \text{NEDC\_share} \cdot \bar{P}_k$$

where,

$\bar{P}_k$	is the power consumption at the LED intensity for each class k as the average of n consecutive measurements.
K	is the number of classes associated with the low beam AFS.
NEDC_share	is the NEDC time share per speed range in each class as defined in Table 2.

TABLE 2

**NEDC time share per speed range**

Speed range	NEDC_share
< 50 km/h	0,6805
50 – 100 km/h	0,2881
> 100 km/h	0,0314

When the low beam AFS does not fall within all four classes specified in Table 1, the NEDC\_share of the missing classes shall be attributed to class C.

2.2.2. Calculation of the power savings

The power savings of each efficient exterior LED light ( $\Delta P_i$ ) [W] shall be calculated in accordance with Formula 3.

Formula 3

$$\Delta P_i = P_{B_i} - \bar{P}_{EI_i}$$

where,

$P_{B_i}$	is the power consumption of the baseline vehicle light i [W]
$\bar{P}_{EI_i}$	is the average power consumption of the eco-innovative vehicle light i [W]

The power consumption of the different baseline vehicle lights is defined in Table 3.



**Changes to legislation:** There are outstanding changes not yet made to Commission Implementing Decision (EU) 2020/1222. Any changes that have already been made to the legislation appear in the content and are referenced with annotations. (See end of Document for details) View outstanding changes

TABLE 3

**Power consumption for different baseline vehicle lights**

Vehicle light	Power consumption (P <sub>B</sub> ) [W]
Low beam headlamp	137
High beam headlamp	150
Front position	12
License plate	12
Front fog lamp	124
Rear fog lamp	26
Front turn signal lamp	13
Rear turn signal lamp	13
Reversing lamp	52
Cornering lamp	44
Static Bending lamp	44
End-outline marker lamps (vehicles width > 2,1 m)	12
Side marker lamps (vehicles length > 6 m)	24

3. CALCULATION OF THE CO<sub>2</sub> SAVINGS

The CO<sub>2</sub> savings shall be calculated in accordance with Formula 4.

Formula 4

$$C_{CO_2} = \left( \sum_{i=1}^m \Delta P_i \cdot UF_i \right) \cdot \frac{V_{Pe}}{\eta_A} \cdot \frac{CF}{v}$$

where,

v	is the mean driving speed of the NEDC, which is 33,58 km/h
η <sub>A</sub>	is the efficiency of the alternator, which is 0,67
UF <sub>i</sub>	is the usage factor of the vehicle light i as defined in Table 4
V <sub>Pe</sub>	is the consumption of effective power for each fuel approved, as defined in Table 5
CF	is the fuel conversion factor as defined in Table 6.

TABLE 4

**Usage factor for different vehicle lights**

Vehicle light	Usage factor (UF)
Low beam headlamp	0,33
High beam headlamp	0,03
Front position	0,36

**Changes to legislation:** There are outstanding changes not yet made to Commission Implementing Decision (EU) 2020/1222. Any changes that have already been made to the legislation appear in the content and are referenced with annotations. (See end of Document for details) [View outstanding changes](#)

License plate	0,36
Front fog lamp	0,01
Rear fog lamp	0,01
Front turn signal lamp	0,15
Rear turn signal lamp	0,15
Reversing lamp	0,01
Cornering lamp	0,025
Static Bending lamp	0,039
End-outline marker lamps (vehicles width > 2,1 m)	0,36
Side marker lamps (vehicles length > 6 m)	0,36

TABLE 5

**Consumption of effective power**

Type of Engine	Consumption of effective power $V_{Pe}$ [l/kWh]
Petrol/E85	0,264
Petrol/E85 Turbo	0,280
Diesel	0,220
LPG	0,342
LPG Turbo	0,363
	Consumption of effective power $V_{Pe}$ [m <sup>3</sup> /kWh]
CNG (G20)	0,259
CNG (G20) Turbo	0,275

TABLE 6

**Fuel Conversion Factor**

Type of fuel	Conversion factor (CF) [g CO <sub>2</sub> /l]
Petrol/E85	2 330
Diesel	2 640
LPG	1 629
	Conversion factor (CF) [g CO <sub>2</sub> /m <sup>3</sup> ]
CNG (G20)	1 795

4. CALCULATION OF THE UNCERTAINTY OF THE CO<sub>2</sub> SAVINGS

---

**Changes to legislation:** There are outstanding changes not yet made to Commission Implementing Decision (EU) 2020/1222. Any changes that have already been made to the legislation appear in the content and are referenced with annotations. (See end of Document for details) View outstanding changes

---

#### 4.1. General methodology

The uncertainty of the CO<sub>2</sub> savings ( $S_{CO_2}$ ) [W] shall be calculated in accordance with Formula 5.

Formula 5

$$S_{CO_2} = \frac{V_{Pe} \cdot CF}{\eta_A \cdot v} \cdot \sqrt{\sum_{i=1}^m (UF_i \cdot S_{P_{EI_i}})^2}$$

where,

$m$  is the number of exterior LED lights in the combination tested.  
 $S_{P_{EI_i}}$  is the statistical margin of the power consumption of each  $i$ -th LED light fitted in the eco-innovative vehicle which shall be calculated in accordance with Formula 6.

Formula 6

$$S_{P_{EI_i}} = \sqrt{\frac{\sum_{j=1}^n (P_{EI_{ij}} - \bar{P}_{EI_i})^2}{n(n-1)}}$$

In case of a low beam AFS the statistical margin of the power consumption ( $S_{P_{EI_{AFS}}}$ ) [W] shall instead be calculated in accordance with Formulas 7 and 8.

Formula 7

$$S_{\bar{P}_k} = \sqrt{\frac{\sum_{j=1}^n (P_{c_j} - \bar{P}_k)^2}{n(n-1)}}$$

Formula 8

$$S_{P_{EI_{AFS}}} = \sqrt{\sum_{k=1}^K (NEDC\_share \cdot S_{\bar{P}_k})^2}$$

where,

$n$  is the number of power consumption measurements, which is at least 5 as indicated in section 2.2.1  
 $i$  corresponds to each vehicle light  
 $j$  refers to an individual measurement of power consumption  
 $\bar{P}_k$  is the average of the  $n$  values of  $P_k$   
 $K$  is the number of classes associated with the low beam AFS.

#### 5. ROUNDING

---

**Changes to legislation:** There are outstanding changes not yet made to Commission Implementing Decision (EU) 2020/1222. Any changes that have already been made to the legislation appear in the content and are referenced with annotations. (See end of Document for details) [View outstanding changes](#)

---

The CO<sub>2</sub> savings ( $C_{CO_2}$ ) and the uncertainty of the CO<sub>2</sub> savings ( $S_{CO_2}$ ) shall be rounded to two decimal places.

Each value used in the calculation of the CO<sub>2</sub> savings shall either be applied unrounded or be rounded to the minimum number of decimal places which allows the maximum total impact (i.e. combined impact of all rounded values) on the savings to be lower than 0,25 [g CO<sub>2</sub>/km].

#### 6. CHECK AGAINST THE MINIMUM CO<sub>2</sub> SAVINGS THRESHOLD

The type-approval authority shall ensure for each type, variant and version of a vehicle fitted with the efficient exterior LED lights that the minimum threshold criterion as specified in Article 9(1)(a) of Implementing Regulation (EU) No 427/2014 is met.

When verifying whether the minimum threshold criterion is met, the type-approval authority shall take into account, in accordance with Formula 9, the CO<sub>2</sub> savings determined in point 3 and the uncertainty determined in point 4.

*Formula 9*

$$C_{CO_2} - S_{CO_2} \geq MT$$

where,

MT is the minimum threshold equal to 1 g CO<sub>2</sub>/km

$C_{CO_2}$  is the CO<sub>2</sub> savings [g CO<sub>2</sub>/km] as defined in point 3

$S_{CO_2}$  is the uncertainty of the CO<sub>2</sub> savings calculated in accordance with point 4 [g CO<sub>2</sub>/km].

#### 7. CERTIFICATION OF THE CO<sub>2</sub> SAVINGS

The type approval authority is to certify the CO<sub>2</sub> savings in accordance with point 3 based on measurements of the LED Lighting system and the baseline halogen lamps using the test methodology set out in this Annex. Where the CO<sub>2</sub> emission savings are below the threshold specified in Article 9(1) of Implementing Regulation (EU) No 427/2014, the second subparagraph of Article 11(2) of that Regulation shall apply.

---

*Changes to legislation:* There are outstanding changes not yet made to Commission Implementing Decision (EU) 2020/1222. Any changes that have already been made to the legislation appear in the content and are referenced with annotations. (See end of Document for details) [View outstanding changes](#)

---

- (1) [OJ L 111, 25.4.2019, p. 13.](#)
- (2) Commission Implementing Regulation (EU) No 427/2014 of 25 April 2014 establishing a procedure for the approval and certification of innovative technologies for reducing CO<sub>2</sub> emissions from light commercial vehicles pursuant to Regulation (EU) No 510/2011 of the European Parliament and of the Council ([OJ L 125, 26.4.2014, p. 57](#)).
- (3) Regulation (EC) No 443/2009 of the European Parliament and of the Council of 23 April 2009 setting emission performance standards for new passenger cars as part of the Community's integrated approach to reduce CO<sub>2</sub> emissions from light-duty vehicles ([OJ L 140, 5.6.2009, p. 1](#)).
- (4) <https://circabc.europa.eu/sd/a/a19b42c8-8e87-4b24-a78b-9b70760f82a9/July%202018%20Technical%20Guidelines.pdf>
- (5) Commission Regulation (EC) No 692/2008 of 18 July 2008 implementing and amending Regulation (EC) No 715/2007 of the European Parliament and of the Council on type-approval of motor vehicles with respect to emissions from light passenger and commercial vehicles (Euro 5 and Euro 6) and on access to vehicle repair and maintenance information ([OJ L 199, 28.7.2008, p. 1](#)).
- (6) Commission Implementing Decision 2014/128/EU of 10 March 2014 on the approval of the light emitting diodes low beam module 'E-Light' as an innovative technology for reducing CO<sub>2</sub> emissions from passenger cars pursuant to Regulation (EC) No 443/2009 of the European Parliament and of the Council ([OJ L 70, 11.3.2014, p. 30](#)).
- (7) Commission Implementing Decision (EU) 2015/206 of 9 February 2015 on the approval of the Daimler AG efficient exterior lighting using light emitting diodes as an innovative technology for reducing CO<sub>2</sub> emissions from passenger cars pursuant to Regulation (EC) No 443/2009 of the European Parliament and of the Council ([OJ L 33, 10.2.2015, p. 52](#)).
- (8) Commission Implementing Decision (EU) 2016/160 of 5 February 2016 on the approval of the Toyota Motor Europe efficient exterior lighting using light emitting diodes as an innovative technology for reducing CO<sub>2</sub> emissions from passenger cars pursuant to Regulation (EC) No 443/2009 of the European Parliament and of the Council ([OJ L 31, 6.2.2016, p. 70](#)).
- (9) Commission Implementing Decision (EU) 2016/587 of 14 April 2016 on the approval of the technology used in efficient vehicle exterior lighting using light emitting diodes as an innovative technology for reducing CO<sub>2</sub> emissions from passenger cars pursuant to Regulation (EC) No 443/2009 of the European Parliament and of the Council ([OJ L 101, 16.4.2016, p. 17](#)).
- (10) Directive 2007/46/EC of the European Parliament and the Council of 5 September 2007 establishing a framework for the approval of motor vehicles and their trailers, and of systems, components and separate technical units intended for such vehicles (Framework Directive) ([OJ L 263, 9.10.2007, p. 1](#)).
- (11) Commission Regulation (EU) 2017/1151 of 1 June 2017 supplementing Regulation (EC) No 715/2007 of the European Parliament and of the Council on type-approval of motor vehicles with respect to emissions from light passenger and commercial vehicles (Euro 5 and Euro 6) and on access to vehicle repair and maintenance information, amending Directive 2007/46/EC of the European Parliament and of the Council, Commission Regulation (EC) No 692/2008 and Commission Regulation (EU) No 1230/2012 and repealing Commission Regulation (EC) No 692/2008 ([OJ L 175, 7.7.2017, p. 1](#)).
- (12) <sup>(1)</sup> [OJ L 4, 7.1.2012, p. 17](#), <sup>(2)</sup> [OJ L 213, 18.7.2014, p. 1](#), <sup>(3)</sup> [OJ L 285, 30.9.2014, p. 1](#), <sup>(4)</sup> [OJ L 250, 22.8.2014, p. 1](#), <sup>(5)</sup> [OJ L 237, 8.8.2014, p. 1](#), <sup>(6)</sup> [OJ L 148, 12.6.2010, p. 55](#), <sup>(7)</sup> [OJ L 323, 6.12.2011, p. 46](#), <sup>(8)</sup> [OJ L 164, 30.6.2010, p. 69](#), <sup>(9)</sup> [OJ L 302, 28.11.2018, p. 114](#), <sup>(10)</sup> [OJ L 250, 22.8.2014, p. 67](#), <sup>(11)</sup> [OJ L 89, 25.3.2014, p. 101](#), <sup>(12)</sup> [OJ L 222, 24.8.2010, p. 1](#).

**Changes to legislation:**

There are outstanding changes not yet made to Commission Implementing Decision (EU) 2020/1222. Any changes that have already been made to the legislation appear in the content and are referenced with annotations.

[View outstanding changes](#)

**Changes and effects yet to be applied to :**

- Annex point 6 words substituted by S.I. 2020/1418 reg. 11(5)(a)
- Annex point 7 words substituted by S.I. 2020/1418 reg. 11(5)(b)
- Art. 2(1) words substituted by S.I. 2020/1418 reg. 11(2)
- Art. 3(1) words substituted by S.I. 2020/1418 reg. 11(3)(a)
- Art. 3(2) words substituted by S.I. 2020/1418 reg. 11(3)(b)
- Art. 3(3) words substituted by S.I. 2020/1418 reg. 11(3)(c)
- Art. 3(4) words substituted by S.I. 2020/1418 reg. 11(3)(d)
- Art. 3(5) words omitted by S.I. 2020/1418 reg. 11(3)(e)(ii)
- Art. 3(5) words substituted by S.I. 2020/1418 reg. 11(3)(e)(i)
- Art. 3(6) words substituted by S.I. 2020/1418 reg. 11(3)(f)(i)
- Art. 3(6) words substituted by S.I. 2020/1418 reg. 11(3)(f)(ii)
- Art. 5 omitted by S.I. 2020/1418 reg. 11(4)