

This document is meant purely as a documentation tool and the institutions do not assume any liability for its contents

► **B**

► **M4 COUNCIL DIRECTIVE**

of 20 March 1970

on the approximation of the laws of the Member States relating to fuel tanks and rear underrun protection of motor vehicles and their trailers ◀

(70/221/EEC)

(OJ L 076 , 6.4.1970, p. 23)

Amended by:

		Official Journal		
	No	page	date	
► M1 Commission Directive 79/490/EEC, of 18 April 1979	L 128	22	26.5.1979	
► M2 amended by commission directive 81/333/EEC, of 13 April 1981	L 131	4	18.5.1981	
► M3 Commission Directive 97/19/EC of 18 April 1997	L 125	1	16.5.1997	
► M4 Directive 2000/8/EC of the European Parliament and of the Council of 20 March 2000	L 106	7	3.5.2000	
► M5 Commission Directive 2006/20/EC of 17 February 2006	L 48	16	18.2.2006	

Amended by:

► A1 Act of Accession of Denmark, Ireland and the United Kingdom of Great Britain and Northern Ireland	L 73	14	27.3.1972
► A2 Act concerning the conditions of accession of the Czech Republic, the Republic of Estonia, the Republic of Cyprus, the Republic of Latvia, the Republic of Lithuania, the Republic of Hungary, the Republic of Malta, the Republic of Poland, the Republic of Slovenia and the Slovak Republic and the adjustments to the Treaties on which the European Union is founded	L 236	33	23.9.2003

Corrected by:

- **C1** Corrigendum, OJ L 065 , 15.3.1979, p. 42 (70/221/EEC)
- **C2** Corrigendum, OJ L 064 , 6.3.2001, p. 39 (8/2000)

▼ **B**▼ **M4****COUNCIL DIRECTIVE****of 20 March 1970****on the approximation of the laws of the Member States relating to fuel tanks and rear underrun protection of motor vehicles and their trailers**▼ **B**

(70/221/EEC)

THE COUNCIL OF THE EUROPEAN COMMUNITIES,

Having regard to the Treaty establishing the European Economic Community and in particular Article 100 thereof;

Having regard to the proposal from the Commission;

Having regard to the Opinion of the European Parliament ⁽¹⁾;Having regard to the Opinion of the Economic and Social Committee ⁽²⁾;

Whereas the technical requirements which motor vehicles must satisfy pursuant to national laws relate, *inter alia* to their liquid fuel tanks and ► **C1** rear underrun protection ◀;

Whereas those requirements differ from one Member State to another; whereas it is therefore necessary that all Member States adopt the same requirements either in addition to or in place of their existing rules, in order, in particular, to allow the EEC type approval procedure which was the subject of the Council Directive ⁽³⁾ of 6 February 1970 on the approximation of the laws of the Member States relating to the type approval of motor vehicles and their trailers to be applied in respect of each type of vehicle;

HAS ADOPTED THIS DIRECTIVE:

▼ **M4***Article 1*

For the purpose of this Directive, 'vehicle' means any motor vehicle and its trailers as defined in Annex II Section A to Directive 70/156/EEC.

▼ **M1***Article 2*▼ **M4**

1. No Member State may refuse to grant EC type-approval or national type-approval for a vehicle on grounds relating to its fuel tanks if such vehicle satisfies the requirements set out in this Directive concerning fuel tanks.

▼ **M1**

2. No Member State may, on grounds relating to rear underrun protection, refuse to grant EEC type-approval or national type-approval for a vehicle if such vehicle satisfies the requirements set out in the Annex concerning rear underrun protection or if such vehicle is fitted with a rear underrun protective device which has been granted type-approval as a technical unit ► **M3** within the meaning of Article 2 of Directive 70/156/EEC and installed in accordance with the requirements set out in item 5 of Annex II. ◀

⁽¹⁾ OJ No C 160, 18.12.1969, p. 7.

⁽²⁾ OJ No C 48, 16.4.1969, p. 16.

⁽³⁾ OJ No L 42, 23.2.1970, p. 1.

▼ **M1**

3. No Member State may refuse to grant EEC type-approval or national type-approval for a rear underrun protective device if such device, considered as a technical unit ► **M3** within the meaning of Article 2 of Directive 70/156/EEC, satisfies the relevant requirements set out in Annex II. ◀

Article 2a▼ **M4**

1. No Member State may refuse or prohibit the sale, registration, entry into service or use of a vehicle on grounds relating to its fuel tanks if such a vehicle satisfies the requirements set out in this Directive concerning fuel tanks.

▼ **M1**

2. No Member State may, on grounds relating to its rear underrun protection, refuse or prohibit the sale, registration, entry into service or use of a vehicle if such a vehicle satisfies the requirements set out in the Annex concerning rear underrun protection or if the vehicle is fitted with a rear underrun protective device which has been granted type-approval as a technical unit ► **M3** within the meaning of Article 2 of Directive 70/156/EEC and installed in accordance with the requirements set out in item 5 of Annex II. ◀

3. No Member State may prohibit the placing on the market of any rear underrun protective device considered as a technical unit within the meaning of ► **M3** Article 2 ◀ of Directive 70/156/EEC if it conforms to a type which has been granted type-approval within the meaning of Article 2 (3).

Article 2b

A Member State which carries out type-approval shall take the measures necessary to ensure that it is informed of any modification to a part or characteristic referred to in ► **M3** items 2.1 and 2.2 of Annex II ◀. The competent authorities of that Member State shall determine whether fresh tests should be carried out on the modified type and a fresh report drawn up. Where such tests reveal that the requirements of this Directive have not been complied with, the modification shall not be authorized.

▼ **M4***Article 3*

Any amendments necessary to adapt the requirements of the Annexes to technical progress, shall be adopted in accordance with the procedure laid down in Article 13 of Directive 70/156/EEC.

▼ **B***Article 4*

1. Member States shall put into force the provisions containing the requirements needed in order to comply with this Directive within eighteen months of its notification and shall forthwith inform the Commission thereof.

2. Member States shall ensure that the texts of the main provisions of national law which they adopt in the field covered by this Directive are communicated to the Commission.

Article 5

This Directive is addressed to the Member States.

▼ **M3****LIST OF ANNEXES**▼ **M4**

- Annex I: Tanks for liquid fuel
- Appendix 1:* Test of resistance to fire
 - Appendix 2:* Dimensions and technical data of firebricks
 - Appendix 3:* Information document
 - Appendix 4:* EC type-approval certificate

▼ **M3**

- Annex II: Rear underrun protection
- Appendix 1:* Information document (vehicle)
 - Appendix 2:* Information document (separate technical unit)
 - Appendix 3:* EC type-approval certificate (vehicle)
 - Appendix 4:* EC type-approval certificate (separate technical unit)
 - Appendix 5:* EC type-approval mark

▼ **M4***ANNEX I***TANKS FOR LIQUID FUEL**

1. SCOPE
 - 1.1. This Annex applies to vehicles to which Directive 70/156/EEC applies.
2. DEFINITIONS

For the purpose of this Annex:

 - 2.1. 'Vehicle type with regard to fuel tanks' means vehicles which do not differ essentially in such respects as:
 - 2.1.1. The structure, shape, dimensions and materials (metal/plastic) of the tank(s);
 - 2.1.2. In vehicles of category M₁ ⁽¹⁾ the position of the tank(s) in the vehicle in so far as it has a negative effect on the requirements of Section 5.10 of this Annex.
 - 2.2. 'Occupant compartment' means the space for occupant accommodation bounded by the roof, floor, side walls, doors, outside glazing, front bulkhead and rear bulkhead.
 - 2.3. 'Unladen mass' means the mass of the vehicle in running order as defined in Section 2.6 of Annex I to Directive 70/156/EEC.
 - 2.4. 'Tank' means the tank(s) designed to contain the liquid fuel, as defined in Section 2.6, used primarily for the propulsion of the vehicle excluding its accessories (filler pipe (if it is a separate element), filler hole, cap, gauge, connections to the engine or to compensate interior excess pressure, etc).
 - 2.5. 'Capacity of the tank' means the tank capacity as specified by the manufacturer.
 - 2.6. 'Liquid fuel' means a fuel which is liquid in normal ambient conditions.
3. APPLICATION FOR EC TYPE-APPROVAL
 - 3.1. The application for type-approval of a type of vehicle with regard to its fuel tanks pursuant to Article 3(4) of Directive 70/156/EEC shall be submitted by the vehicle manufacturer.
 - 3.2. A model for the information document is given in Appendix 3.
 - 3.3. The following must be submitted to the technical service responsible for conducting the type-approval tests:
 - 3.3.1. A vehicle representative of the vehicle type to be approved or the parts of the vehicle which the technical service deems necessary for approval tests;
 - 3.3.2. In the case of a vehicle equipped with a tank made of a plastic material: seven additional tanks, with their accessories;
 - 3.3.3. In the case of a vehicle equipped with a tank made of another material: two additional tanks, with their accessories.
4. GRANTING OF EC TYPE-APPROVAL
 - 4.1. If the relevant requirements are satisfied, EC type-approval pursuant to Article 4(3) and, if applicable, Article 4(4) of Directive 70/156/EEC shall be granted.
 - 4.2. A model for the EC type-approval certificate is given in Appendix 4.
 - 4.3. An approval number in accordance with Annex VII to Directive 70/156/EEC shall be assigned to each type of vehicle approved. The same Member State shall not assign the same number to another type of vehicle.
5. SPECIFICATIONS
 - 5.1. Tanks must be made so as to be corrosion-resistant.

⁽¹⁾ As defined in Annex II, Part A to Directive 70/156/EEC.

▼ **M4**

- 5.2. Tanks must satisfy, when equipped with all accessories which are normally attached to them, the leakage tests carried out according to Section 6.1 at a relative internal pressure equal to double the working excess pressure, but in any event not less than an excess pressure of 0,3 bar.
- Tanks for vehicles made of a plastic material are considered as meeting this requirement if they have passed the test described in Section 6.3.2.
- 5.3. Any excess pressure or any pressure exceeding the working pressure must be compensated automatically by suitable devices (vents, safety valves, etc).
- 5.4. The vents must be designed in such a way as to prevent any fire risk. In particular, any fuel which may leak when the tank(s) is (are) being filled must not be able to fall on the exhaust system. It shall be channelled to the ground.
- 5.5. The tank(s) must not be situated in, or form, a surface (floor, wall, bulkhead) of the occupant compartment or other compartment integral with it.
- 5.6. A partition must be provided to separate the occupant compartment from the tank(s). The partition may contain apertures (e. g. to accommodate cables) provided they are so arranged that fuel cannot flow freely from the tank(s) into the occupant compartment or other compartment integral with it during normal conditions of use.
- 5.7. Every tank must be securely fixed and so placed as to ensure that any fuel leaking from the tank or its accessories will escape to the ground and not into the occupant compartment during normal conditions of use.
- 5.8. The filler hole must not be situated in the occupant compartment, in the luggage compartment or in the engine compartment.
- 5.9. The fuel must not escape through the tank cap or through the devices provided to compensate excess pressure during the foreseeable course of operation of the vehicle. In the case of overturning of the vehicle, a drip may be tolerated provided that it does not exceed 30 g/min; this requirement must be verified during the test prescribed in Section 6.2.
- 5.9.1. The tank cap must be fixed to the filler pipe: the seal must be retained securely in place, the cap must latch securely in place against the seal and filler pipe when closed.
- 5.9.1.1. The requirements of Section 5.9.1 will be deemed to be satisfied if the vehicle meets the requirements of Section 5.1.3 of Annex I to Directive 70/220/EEC ⁽¹⁾, subject to the proviso that the examples listed in the third indent of that section do not apply to vehicles in categories other than M₁ or N₁.
- 5.10. Tanks must be installed in such a way as to be protected from the consequences of an impact to the front or the rear of the vehicle; there shall be no protruding parts, sharp edges, etc. near the tank.
- 5.11. The fuel tank and the filler neck shall be designed and installed in the vehicles in such a way as to avoid any accumulation of static electricity charges on their entire surface. If necessary, they shall be discharged into the metallic structure of the chassis or any major metallic mass by means of a good conductor.
- 5.12. Moreover, tanks made of plastic material must also be tested according to the specific procedure set out in Section 6.3.

6. TESTS

6.1. **Hydraulic test**

The tank must be subjected to a hydraulic internal pressure test which must be carried out on an isolated unit complete with all its accessories. The tank must be completely filled with a non-flammable liquid (water, for example). After all communication with the outside has been cut off, the pressure must be gradually increased, through the pipe connection through which fuel is fed to the engine, to a relative internal pressure equal to double the working pressure used and in any case to not less than an excess pressure of 0,3 bar, which must be maintained for one minute. During this time the tank shell must not crack or leak; however, it may be permanently deformed.

6.2. **Overturn test**

⁽¹⁾ OJ L 76, 6.4.1970, p. 1.

▼ **M4**

- 6.2.1. The tank and all its accessories must be mounted on to a test fixture in a manner corresponding to the mode of installation on the vehicle for which the tank is intended; this also applies to systems for the compensation of the interior excess pressure.
- 6.2.2. The test fixture shall rotate about an axis lying parallel to the longitudinal vehicle axis.
- 6.2.3. The test will be carried out with the tank filled to 90 % of its capacity and also 30 % of its capacity with a non-flammable liquid having a density and a viscosity close to those of the fuel normally used (water may be accepted).
- 6.2.4. The tank must be turned from its installed position 90° to the right. The tank must remain in this position for at least five minutes.
- The tank must then be turned 90° further in the same direction. The tank must be held in this position, in which it is completely inverted, for at least another five minutes.
- The tank must be rotated back to its normal position. Testing liquid which has not flowed back from the venting system into the tank must be drained and replenished if necessary.
- The tank must be rotated 90° in the opposite direction and left for at least five minutes in this position.
- The tank must be rotated 90° further in the same direction. This completely inverted position must be maintained for at least five minutes. Afterwards, the tank must be rotated back to its normal position.
- 6.3. **Additional tests for tank(s) for vehicles made of a plastic material**
- 6.3.1. *Impact resistance*
- 6.3.1.1. The tank must be filled to its capacity with a water-glycol mixture or with another liquid having a low freezing point which does not change the properties of the tank material, and must then be subjected to a perforation test.
- 6.3.1.2. During this test the tank temperature must be $233\text{ K} \pm 2\text{ K}$ ($-40\text{ °C} \pm 2\text{ °C}$).
- 6.3.1.3. A pendulum impact testing fixture must be used for the test. The impact body must be of steel and have the shape of a pyramid with equilateral-triangle faces and a square base, the summit and the edges being rounded to a radius of 3 mm. The centre of percussion of the pendulum must coincide with the centre of gravity of the pyramid; its distance from the axis of rotation of the pendulum must be 1 m. The total mass of the pendulum must be 15 kg. The energy of the pendulum at the moment of impact must be not less than 30 Nm and as close to that value as possible.
- 6.3.1.4. The tests must be made on the points of the tank which are regarded as vulnerable to frontal or rear collisions. The points regarded as vulnerable are those which are most exposed or weakest having regard to the shape of the tank or the way in which it is installed on the vehicle. The points selected by the laboratories must be indicated in the test report.
- 6.3.1.5. During the test, the tank must be held in position by the fittings on the side or sides opposite the side of impact. No leak must result from the test.
- 6.3.1.6. At the choice of the manufacturer, all the impact tests may be carried out on one tank or each may be carried out on a different tank.
- 6.3.2. *Mechanical strength*
- The tank must be tested under the conditions prescribed in Section 6.1 for leaks and for rigidity of shape. The tank and all its accessories must be mounted onto a test fixture in a manner corresponding to the mode of installation on the vehicle for which the tank is intended. Water at 326 K (53 °C) must be used as the testing fluid and must fill the tank to its capacity. The tank must be subjected to a relative internal pressure equal to double the working pressure and in any case to not less than 0,3 bar at a temperature of $326\text{ K} \pm 2\text{ K}$ ($53\text{ °C} \pm 2\text{ °C}$) for a period of five hours. During the test, the tank and its accessories must not crack or leak; however, it may be permanently deformed.
- 6.3.3. *Fuel permeability*

▼ **M4**

- 6.3.3.1. The fuel used for the permeability test must be either the reference fuel specified in Annex VIII to Directive 70/220/EEC or a commercial premium-grade fuel. If the tank is only designed for installation on vehicles with a compression-ignition engine, the tank shall be filled with diesel fuel.
- 6.3.3.2. Prior to the test, the tank must be filled to 50 % of its capacity with testing fuel and stored, without being sealed, at an ambient temperature of $313\text{ K} \pm 2\text{ K}$ ($40\text{ °C} \pm 2\text{ °C}$) until the weight loss per unit time becomes constant.
- 6.3.3.3. The tank must then be emptied and refilled to 50 % of its capacity with test fuel, after which it must be hermetically sealed and be stored at a temperature of $313\text{ K} \pm 2\text{ K}$ ($40\text{ °C} \pm 2\text{ °C}$). The pressure must be adjusted when the contents of the tank have reached the testing temperature. During the ensuing test period of eight weeks, the loss of weight due to diffusion during the test period shall be determined. The maximum permissible average loss of fuel is 20 g per 24 hours of testing time.
- 6.3.3.4. If the loss due to diffusion exceeds the value indicated in Section 6.3.3.3, the test described there must be carried out again, on the same tank, to determine the loss by diffusion at $296\text{ K} \pm 2\text{ K}$ ($23\text{ °C} \pm 2\text{ °C}$), but under the same conditions otherwise. The loss so measured shall not exceed 10 g per 24 hours.
- 6.3.4. *Resistance to fuel*
- After the test referred to in Section 6.3.3, the tank must still meet the requirements set out in Sections 6.3.1 and 6.3.2.
- 6.3.5. *Resistance to fire*
- The tank must be subjected to the following tests.
- 6.3.5.1. For two minutes the tank, fixed as on the vehicle, must be exposed to flame. There must be no leakage of liquid fuel from the tank.
- 6.3.5.2. Three tests must be made on different tanks filled with fuel as follows:
- 6.3.5.2.1. If the tank is designed for installation on vehicles equipped with either a positive ignition engine or a compression ignition engine, three tests must be carried out with tanks filled with premium-grade gasoline;
- 6.3.5.2.2. If the tank is only designed for installation on vehicles equipped with a compression-ignition engine, three tests must be carried out with tanks filled with diesel fuel;
- 6.3.5.2.3. For each test the tank must be installed in a testing fixture simulating actual installation conditions as far as possible. The method whereby the tank is fixed in the fixture must correspond to the relevant specifications for the vehicle. Vehicle parts which protect the tank and its accessories against exposure to flame or which affect the course of the fire in any way, as well as specified components installed on the tank and plugs, must be taken into consideration. All openings must be closed during the test, but venting systems must remain operative. Immediately prior to the test the tank must be filled with the specified fuel to 50 % of its capacity.
- 6.3.5.3. The flame to which the tank is exposed must be obtained by burning commercial fuel for positive-ignition engines (hereafter called 'fuel') in a pan. The quantity of fuel poured into the pan shall be sufficient to permit the flame, under free-burning conditions, to burn for the whole test procedure.
- 6.3.5.4. The pan dimensions must be chosen so as to ensure that the sides of the fuel tank are exposed to the flame. The pan must therefore exceed the horizontal projection of the tank by at least 20 cm, but not more than 50 cm. The side walls of the pan must not project more than 8 cm above the level of the fuel at the start of the test.
- 6.3.5.5. The pan filled with fuel must be placed under the tank in such a way that the distance between the level of the fuel in the pan and the tank bottom corresponds to the design height of the tank above the road surface at the unladen mass (see Section 2.3). Either the pan, or the testing fixture, or both, must be freely movable.
- 6.3.5.6. During phase C of the test, the pan must be covered ► **C2** by a screen placed $3\text{ cm} \pm 1\text{ cm}$ above the fuel level. ◀ The screen must be made of a refractory material, as prescribed in Appendix 2. There must be no gap between the bricks and they must be supported over the fuel pan in such a manner that the holes in the bricks are not obstructed.

▼ **M4**

The length and width of the frame must be 2 cm to 4 cm smaller than the interior dimensions of the pan so that a gap of 1 cm to 2 cm exists between the frame and the wall of the pan to allow ventilation.

- 6.3.5.7. When the tests are carried out in the open air, sufficient wind protection must be provided and the wind velocity at fuel-pan level must not exceed 2,5 km/h. Before the test the screen must be heated to 308 K \pm 5 K (35 °C \pm 5 °C). The fire bricks may be wetted in order to guarantee the same test conditions for each successive test.
- 6.3.5.8. The test must comprise four phases (see Appendix 1).
- 6.3.5.8.1. **Phase A: Pre-heating (figure 1)**
- The fuel in the pan must be ignited at a distance of at least 3 m from the tank being tested. After 60 seconds pre-heating, the pan must be placed under the tank.
- 6.3.5.8.2. **Phase B: Direct exposure to flame (figure 2)**
- For 60 seconds the tank must be exposed to the flame from the freely burning fuel.
- 6.3.5.8.3. **Phase C: Indirect exposure to flame (figure 3)**
- As soon as phase B has been completed, the screen must be placed between the burning pan and the tank. The tank must be exposed to this reduced flame for a further 60 seconds.
- 6.3.5.8.4. **Phase D: End of test (figure 4)**
- The burning pan covered with the screen must be moved back to its original position (phase A). If, at the end of the test, the tank is burning, the fire must be extinguished forthwith.
- 6.3.5.9. The results of the test shall be considered satisfactory if no liquid fuel is leaking from the tank.
- 6.3.6. *Resistance to high temperature*
- 6.3.6.1. The fixture used for the test must match the manner of installation of the tank on the vehicle, including the way in which the tank vent works.
- 6.3.6.2. The tank filled to 50 % of its capacity with water at 293 K (20 °C) must be subjected for one hour to an ambient temperature of 368 K \pm 2 K (95 °C \pm 2 °C).
- 6.3.6.3. The results of the test shall be considered satisfactory if, after the test, the tank is not leaking or seriously deformed.
- 6.3.7. *Markings on the fuel tank*
- 6.3.7.1. The trade name or mark must be affixed to the tank; it must be indelible and clearly legible on the tank when the latter is installed on the vehicle.
7. AMENDMENTS TO APPROVAL
- 7.1. In the case of amendments to approvals granted pursuant to this Directive, the provisions of Article 5 of Directive 70/156/EEC shall apply.
8. CONFORMITY OF PRODUCTION
- 8.1. Measures to ensure the conformity of production shall be taken in accordance with the provisions laid down in Article 10 of Directive 70/156/EEC.

▼ M4

Appendix 1

TEST OF RESISTANCE TO FIRE

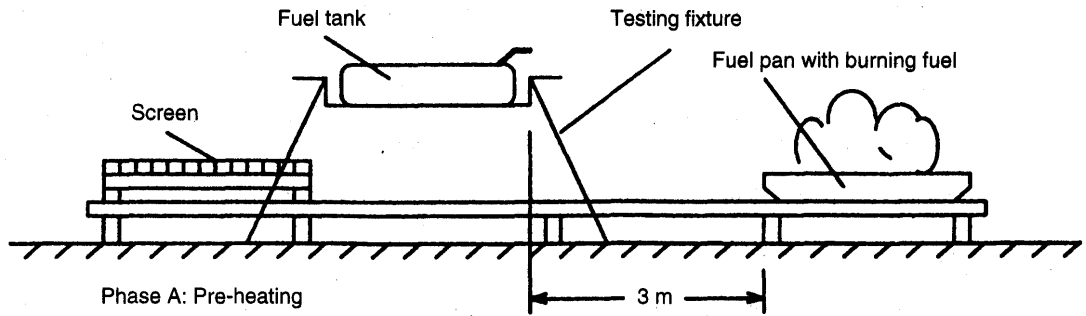

Figure 1

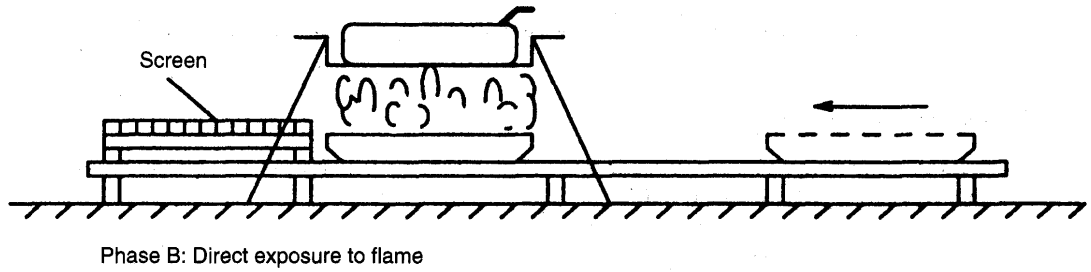

Figure 2

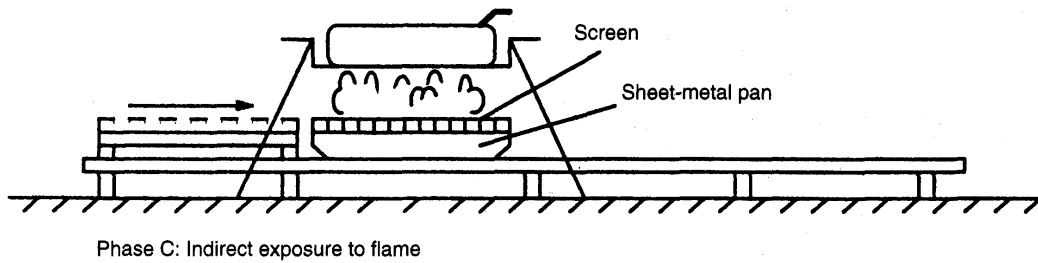

Figure 3

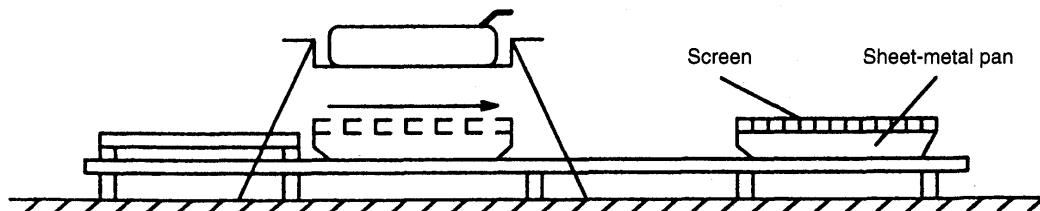
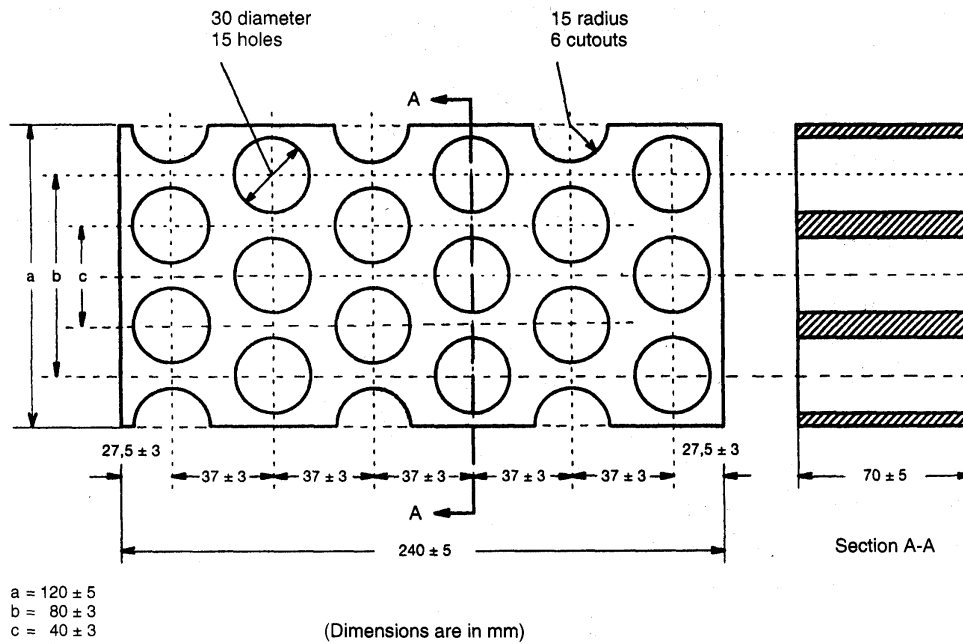

Figure 4

▼ M4

Appendix 2

DIMENSIONS AND TECHNICAL DATA OF FIREBRICKS



Fire resistance (Sege-Kegel)	SK 30
Al ₂ O ₃ content	30 to 33 %
Open porosity (Po)	20 to 22 % vol.
Density	1 900 to 2 000 kg/m ³
Effective holed area	44,18 %

INFORMATION DOCUMENT No ...

in accordance with Annex I to Directive 70/156/EEC (*) relating to EC type-approval of a vehicle type with regard to its liquid fuel tanks*(Directive 70/221/EEC, as last amended by Directive 2000/8/EC)*

The following information, if applicable, must be supplied in triplicate and include a list of contents. Any drawings must be supplied in appropriate scale and in sufficient detail on size A4 or on a folder of A4 format. Photographs, if any, must show sufficient detail.

If the systems, components or separate technical units have electronic controls, information concerning their performance must be supplied.

0. GENERAL
- 0.1. Make (trade name of manufacturer):
- 0.2. Type and general commercial description(s):
- 0.3. Means of identification of type, if marked on the vehicle ^(b):
- 0.3.1. Location of that marking:
- 0.4. Category of vehicle ^(c):
- 0.5. Name and address of the manufacturer:
- 0.8. Address(es) of assembly plant(s):
1. GENERAL CONSTRUCTION CHARACTERISTICS OF THE VEHICLE
- 1.1. Photographs and/or drawings of a representative vehicle (different body styles only):
3. POWER PLANT ^(d)
- 3.2.2. Fuel: diesel oil/petrol/LPG/any other ⁽¹⁾
- 3.2.3. Fuel tank(s)
- 3.2.3.1. Service fuel tank(s)
- 3.2.3.1.1. Number, capacity, material:
- 3.2.3.1.2. Drawing and technical description of the tank(s) with all connections and all lines of the breathing and venting system, locks, valves, fastening devices:
- 3.2.3.1.3. Drawing showing clearly the position of the tanks in the vehicle:
- 3.2.3.2. Reserve fuel tank(s)
- 3.2.3.2.1. Number, capacity, material:
- 3.2.3.2.2. Drawing and technical description of the tank(s) with all connections and all lines of the breathing and venting system, locks, valves, fastening devices:
- 3.2.3.2.3. Drawing showing clearly the position of the tank(s) in the vehicle:
-
(Date, file)

(*) The item numbers and footnotes used in this information document correspond to those set out in Annex I to Directive 70/156/EEC. Items not relevant for the purpose of this Directive are omitted.

(1) Delete where not applicable.

▼ **M4**

Appendix 4

MODEL

(maximum format: A4 (210 × 297 mm))

EC TYPE-APPROVAL CERTIFICATE

Stamp of administration

Communication concerning the:

- type-approval ⁽¹⁾,
- extension of type-approval ⁽¹⁾,
- refusal of type-approval ⁽¹⁾,
- withdrawal of type-approval ⁽¹⁾,

of a type of vehicle/component/separate technical unit ⁽¹⁾ with regard to Directive 70/221/EEC as last amended by Directive 2000/8/EC.:

Type-approval number:

Reason for extension:

SECTION I

- 0.1. Make (trade name of manufacturer):
- 0.2. Type and general commercial description(s):
- 0.3. Means of identification of type, if marked on the vehicle/component/separate technical unit ⁽¹⁾ ⁽²⁾:
- 0.3.1. Location of that marking:
- 0.4. Category of vehicle ⁽¹⁾ ⁽³⁾:
- 0.5. Name and address of manufacturer:
- 0.7. In the case of components and separate technical units, location and method of affixing of the EC approval mark:
- 0.8. Address(es) of assembly plant(s):

SECTION II

- 1. Additional information (where applicable): see Addendum
- 2. Technical service responsible for carrying out the tests:
- 3. Date of test report:
- 4. Number of test report:
- 5. Remarks (if any): see Addendum

▼ **M4**

6. Place:
7. Date:
8. Signature:
9. The index to the information package lodged with the approval authority, which may be obtained on request, is attached.

(¹) Delete where not applicable.

(²) If the means of identification of type contains characters not relevant to describe the vehicle, component or separate technical unit types covered by this type-approval certificate, such characters shall be represented in the documentation by the symbol: '?' (e.g. ABC??123??).

(³) As defined in Annex II, Section A to Directive 70/156/EEC.

Addendum to EC type-approval certificate No ...

concerning the type-approval of a vehicle with regard to Directive 70/221/EEC (fuel tanks) as last amended by Directive 2000/8/EC

1. Additional information
 - 1.1. Material:
 - 1.2. Capacity:
 - 1.3. Location(s):
 - 1.4. Fuel: diesel oil/petrol/any other (¹):
5. Remarks:

(¹) Delete where not applicable.

▼ **M3***ANNEX II***REAR UNDERRUN PROTECTION**

1. GENERAL

Vehicles covered by this Directive must be designed so as to provide effective protection against underrunning from the rear by vehicles of categories M₁ and N₁ ⁽¹⁾.
2. DEFINITIONS
 - 2.1. Vehicle type for the purposes of rear underrun protection

The term 'vehicle type for the purposes of rear underrun protection' means vehicles which do not differ essentially with respect to the following main characteristics:

 - 2.1.1. width of the rear axle, structure, dimensions, shape and materials of the rear part of the vehicle in so far as they have a bearing on the requirements of 5.1 to 5.4.5.5;
 - 2.1.2. suspension characteristics in so far as they have a bearing on the requirements of 5.1 to 5.4.5.5;
 - 2.1.3. type of rear underrun protection device, if fitted.
 - 2.2. Type of rear underrun protection device

The term 'type of rear underrun protection device' means devices which do not differ essentially with respect to the following main characteristics:

 - 2.2.1. shape;
 - 2.2.2. dimensions;
 - 2.2.3. attachment;
 - 2.2.4. materials.
3. APPLICATION FOR EC TYPE-APPROVAL
 - 3.1. Application for EC type-approval in respect of a vehicle type
 - 3.1.1. Application for EC type-approval pursuant to Article 3 (4) of Directive 70/156/EEC of a vehicle type with regard to rear underrun protection shall be submitted by the vehicle manufacturer.
 - 3.1.2. A model for the information document is given in Appendix 1.
 - 3.1.3. A vehicle representative of the type to be approved shall be submitted to the technical service responsible for conducting the type-approval tests.
 - 3.2. Application for EC type-approval in respect of a rear underrun protective device considered to be a separate technical unit
 - 3.2.1. Application for EC type-approval pursuant to Article 3 (4) of Directive 70/156/EEC in respect of a rear underrun protective device considered to be a separate technical unit within the meaning of Article 2 of that Directive shall be submitted by the vehicle manufacturer or the manufacturer of the rear underrun protective device.
 - 3.2.2. A model for the information document is given in Appendix 2.
 - 3.2.3. One sample of the type of rear underrun protective device to be approved shall be submitted to the technical service conducting the tests. That service may, if it is considered necessary, request a further sample. The samples shall be clearly and indelibly marked with the applicant's trade name or mark and the type designation.
4. GRANTING OF EC TYPE-APPROVAL
 - 4.1. If the relevant requirements are satisfied, EC type-approval pursuant to Article 4 (3) and, if applicable, Article 4 (4) of Directive 70/156/EEC shall be granted.
 - 4.2. A model for the EC type-approval certificate is shown in:
 - 4.2.1. Appendix 3 for applications referred to in 3.1; and

⁽¹⁾ As defined in Annex II Section A to Directive 70/156/EEC.

▼ **M3**

- 4.2.2. Appendix 4 for applications referred to in 3.2.
- 4.3. An approval number in accordance with Annex VII to Directive 70/156/EEC shall be assigned to each type of vehicle or each type of rear protective device approved. The same Member State shall not assign the same number to another type of vehicle or to another type of rear protective device.
5. SPECIFICATIONS
- 5.1. All vehicles must be so constructed and/or equipped as to offer effective protection over their whole width against underrunning from the rear by a vehicle of categories M₁ and N₁ ⁽¹⁾.

▼ **M5**

- 5.1a. The vehicle shall be tested under the following conditions:
- it must be at rest on a level, flat, rigid and smooth surface,
 - the front wheels must be in the straight-ahead position,
 - tyres must be inflated to the pressure recommended by the vehicle manufacturer,
 - the vehicle may, if necessary to achieve the test forces required, be restrained by any method specified by the vehicle manufacturer,
 - if the vehicle is equipped with hydropneumatic, hydraulic or pneumatic suspension or a device for automatic levelling according to load, it must be tested with the suspension or device in the normal running condition specified by the manufacturer.

▼ **M3**

- 5.2. Any vehicle in one of the categories M₁, M₂, M₃, N₁, O₁ or O₂ ⁽¹⁾ will be deemed to satisfy the condition set out in 5.1:
- if it satisfies the conditions set out in 5.3, or
 - if the ground clearance of the rear part of the unladen vehicle does not exceed 55 cm over a width which is not shorter than that of the rear axle by more than 10 cm on either side (excluding any tyre bulging close to the ground).

Where there is more than one rear axle, the width to be considered is that of the widest.

This requirement must be satisfied at least on a line at a distance of not more than 45 cm from the rear extremity of the vehicle.

- 5.3. Any vehicle in one of the categories N₂, N₃, O₃ or O₄ ⁽¹⁾ will be deemed to satisfy the condition set out in 5.1 provided that:
- the vehicle is equipped with a special rear underrun protective device in accordance with the requirements of 5.4, or
 - the vehicle is so designed and/or equipped at the rear that, by virtue of their shape and characteristics, its component parts can be regarded as replacing the rear underrun protective device. Components whose combined function satisfies the requirements set out in 5.4 are considered to form a rear underrun protective device.
- 5.4. A device for protection against underrunning from the rear, hereinafter referred to as 'device', generally consists of a cross-member and linking components connected to the chassis side-members or to whatever replaces them.
- It must have the following characteristics:
- 5.4.1. the device must be fitted as close to the rear of the vehicle as possible. When the vehicle is unladen ⁽²⁾ the lower edge of the device must at no point be more than 55 cm above the ground;
- 5.4.2. the width of the device must at no point exceed the width of the rear axle measured at the outermost points of the wheels, excluding the bulging of the tyres close to the ground, nor must it be more than 10 cm shorter on either side. Where there is more than one rear axle, the width to be considered is that of the widest;
- 5.4.3. the section height of the cross-member must be not less than 10 cm. The lateral extremities of the cross-member must not bend to the rear or have a sharp outer edge; this condition is fulfilled when the lateral extremities of the cross-member are rounded on the outside and have a radius of curvature of not less than 2,5 mm;

⁽¹⁾ As defined in Annex II Section A to Directive 70/156/EEC.

⁽²⁾ As defined in item 2.6 of Appendix 1.

▼ M3

5.4.4. the device may be so designed that its position at the rear of the vehicle can be varied. In this event, there must be a guaranteed method of securing it in the service position so that any unintentional change of position is precluded. It must be possible for the operator to vary the position of the device by applying a force not exceeding 40 daN;

5.4.5. the device must offer adequate resistance to forces applied parallel to the longitudinal axis of the vehicle, and be connected, when in the service position, with the chassis side-members or whatever replaces them.

This requirement will be satisfied if it is shown that both during and after the application the horizontal distance between the rear of the device and the rear extremity of the vehicle does not exceed 40 cm at any of the points P1, P2 and P3. In measuring this distance, any part of the vehicle which is more than 3 m above the ground when the vehicle is unladen must be excluded;

5.4.5.1. points P1 are located 30 cm from the longitudinal planes tangential to the outer edges of the wheels on the rear axle; points P2, which are located on the line joining points P1, are symmetrical to the median longitudinal plane of the vehicle at a distance from each other of 70 to 100 cm inclusive, the exact position being specified by the manufacturer. The height above the ground of points P1 and P2 must be defined by the vehicle manufacturer within the lines that bound the device horizontally. The height must not, however, exceed 60 cm when the vehicle is unladen. P3 is the centre-point of the straight line joining points P2;

▼ M5

5.4.5.2. A horizontal force corresponding to 25 % of the maximum technically permissible mass of the vehicle but not exceeding 5×10^4 N must be applied successively to both points P1 and to point P3;

▼ M3

5.4.5.3. a horizontal force corresponding to 50 % of the maximum technically permissible mass of the vehicle but not exceeding 10×10^4 N must be applied successively to both points P2;

5.4.5.4. the forces specified in 5.4.5.2 and 5.4.5.3 above must be applied separately. The order in which the forces are applied may be specified by the manufacturer;

5.4.5.5. whenever a practical test is performed to verify compliance with the abovementioned requirements, the following conditions must be fulfilled:

5.4.5.5.1. the device must be connected to the chassis side-members of the vehicle or to whatever replaces them;

5.4.5.5.2. the specified forces must be applied by rams which are suitably articulated (e.g. by means of universal joints) and must be parallel to the median longitudinal plane of the vehicle via a surface not more than 25 cm in height (the exact height must be indicated by the manufacturer) and 20 cm wide, with a radius of curvature of 5 ± 1 mm at the vertical edges; the centre of the surface is placed successively at points P1, P2 and P3.

▼ M5

5.4a. For vehicles fitted with a platform lift the fitting of the underrun device may be interrupted for the purposes of the mechanism. In such cases, the following must apply:

5.4a.1. the lateral distance between the fitting elements of the underrun device and the elements of the platform lift, which make the interruption necessary, may amount to no more than 2,5 cm;

5.4a.2. the individual elements of the underrun protection device must, in each case, have an effective surface area of at least 350 cm²;

5.4a.3. the individual elements of the underrun protection device must be of sufficient dimensions to comply with the requirements of paragraph 5.4.5.1, whereby the relative positions of the test points are determined. If the points P1 are located within the interruption area mentioned in 5.4a, the points P1 to be used will be located in the middle of any lateral section of the rear underrun protection device;

5.4a.4. for the area of interruption of the underrun device and for the purposes of the platform lift, point 5.4.1. need not apply.

▼ M3

5.5. By way of derogation from the abovementioned requirements, vehicles of the following categories need not comply with the requirements of this Annex as regards rear underrun protection:

- tractors for semi-trailers,
- ‘slung’ trailers and other similar trailers for the transport of logs or other very long items,
- vehicles for which rear underrun protection is incompatible with their use.

6. EC TYPE-APPROVAL MARKING

6.1. Every rear underrun protective device conforming to the type approved pursuant to this Directive as a separate technical unit shall bear an EC type-approval mark.

6.2. This mark shall consist of a rectangle surrounding the letter ‘e’ followed by the distinguishing number or letters of the Member State which has granted type-approval:

- 1 for Germany
- 2 for France
- 3 for Italy
- 4 for the Netherlands
- 5 for Sweden
- 6 for Belgium

▼ A2

- 7 for Hungary
- 8 for the Czech Republic

▼ M3

- 9 for Spain
- 11 for the United Kingdom
- 12 for Austria
- 13 for Luxembourg
- 17 for Finland
- 18 for Denmark

▼ A2

- 20 for Poland

▼ M3

- 21 for Portugal
- 23 for Greece

▼ A2

- 26 for Slovenia
- 27 for Slovakia
- 29 for Estonia
- 32 for Latvia
- 36 for Lithuania
- CY for Cyprus

▼ M3

IRL for Ireland

▼ A2

MT for Malta.

▼ M3

It must also include in the vicinity of the rectangle the ‘base approval number’ contained in Section 4 of the type-approval number referred to in Annex VII of Directive 70/156/EEC, preceded by the two figures indicating the sequence number assigned to the most recent major technical amendment to Directive 70/221/EEC on the date EC type-approval was granted. In this Directive the sequence number is ‘00’.

6.3. The EC type-approval mark must be affixed to the rear underrun protective device in such a way as to be indelible and clearly legible even if the device is fitted to a vehicle.

6.4. An example of the EC type-approval mark is shown in Appendix 5.

▼ M3

7. MODIFICATIONS OF THE TYPE AND AMENDMENTS TO APPROVALS
 - 7.1. In the case of modifications of the type approved pursuant to this Directive, the provisions of Article 5 of Directive 70/156/EEC shall apply.
8. CONFORMITY OF PRODUCTION
 - 8.1. As a general rule, measures to ensure the conformity of production shall be taken in accordance with the provisions laid down in Article 10 to Directive 70/156/EEC.

Appendix I

INFORMATION DOCUMENT No ...

pursuant to Annex I to Directive 70/156/EEC(*) relating to EC type-approval of a vehicle with respect to the rear underrun protection

(Directive 70/221/EEC as last amended by Directive .../.../EC)

The following information, if applicable, must be supplied in triplicate and include a list of contents. Any drawings must be supplied in appropriate scale and in sufficient detail on size A4 or on a folder of A4 format. Photographs, if any, must show sufficient detail.

If the systems, components or separate technical units have electronic controls, information concerning their performance must be supplied.

0. GENERAL
 - 0.1. Make (trade name of manufacturer):
 - 0.2. Type and general commercial description(s):
 - 0.3. Means of identification of type, if marked on the vehicle^(b):
 - 0.3.1. Location of that marking:
 - 0.4. Category of vehicle^(c):
 - 0.5. Name and address of manufacturer:
 - 0.8. Address(es) of assembly plant(s):
1. GENERAL CONSTRUCTION CHARACTERISTICS OF THE VEHICLE
 - 1.1. Photographs and/or drawings of a representative vehicle:
 - 1.5. Material used for the side-members^(d):
2. MASSES AND DIMENSIONS^(e)
(in kg and mm) (refer to drawing where applicable)
 - 2.3.3. Width of the widest rear axle:
 - 2.4. Range of vehicle dimensions (overall)
 - 2.4.1. For chassis without bodywork
 - 2.4.1.2. Width^(b):
 - 2.4.2. For chassis with bodywork
 - 2.4.2.2. Width^(b):
 - 2.6. Mass of the vehicle with bodywork, and with coupling device in the case of a towing vehicle of a category other than M₁, in running order, or the mass of the chassis with cab if the manufacturer does not fit the bodywork and/or coupling device (including coolant, oils, fuel, 100 % other liquids except used waters, tools, spare wheel and driver, and, for buses and coaches, the mass of the crew member (75 kg) if there is a crew seat in the vehicle^(e) ^(f)):
 - 2.8. Technically permissible maximum laden mass stated by the manufacturer^(g) (maximum and minimum):

(*) The item numbers and footnotes used in this information document correspond to those set out in Annex I to Directive 70/156/EEC. Items not relevant for the purpose of this Directive are omitted.

▼ **M3**

9. BODYWORK

9.1. Type of bodywork(*):

9.2. Material used and method of construction(*):

9.15. Rear underrun protection

9.15.1. Drawings of the vehicle parts relevant to the rear underrun protection, i.e. drawing of the vehicle and/or chassis with position and mounting of the widest rear axle, drawing of the mounting and/or fitting of the rear underrun protection. If the underrun protection is no special device, the drawing must clearly show that the required dimensions are met:

9.15.2. In the case of special device, full description and/or drawing of the rear underrun protection (including mountings and fittings), or, if approved as a separate technical unit, type approval number:

.....
(Date, file)

.....
(*) If applicable, when part of the bodywork forms a part of the rear underrun protection.

▼ **M3***Appendix 2***INFORMATION DOCUMENT No ...****relating to EC type-approval as a separate technical unit with respect of a rear underrun protective device***(Directive 70/221/EEC as last amended by Directive .../.../EC)*

The following information, if applicable, must be supplied in triplicate and include a list of contents. Any drawings must be supplied in appropriate scale and in sufficient detail on size A4 or on a folder of A4 format. Photographs, if any, must show sufficient detail.

If the systems, components or separate technical units have electronic controls, information concerning their performance must be supplied.

0. GENERAL

- 0.1. Make (trade name of manufacturer):
- 0.2. Type and general commercial description(s):
- 0.5. Name and address of manufacturer:
- 0.7. In the case of components and separate technical units, location and method of affixing of the EC approval mark:
- 0.8. Address(es) of assembly plant(s):

1. GENERAL CONSTRUCTION CHARACTERISTICS OF THE VEHICLE(S) on which the device is intended to be fitted in so far as they relate to the rear underrun protection (attach photographs and/or drawings):

- 1.1. Minimum sum of the moments of inertia about the horizontal axis of the chassis side-members in cross-section:
- 1.2. Distance between the chassis side-members at the mounting points of the device:

2. MASS AND DIMENSIONS

- 2.1. Technically permissible maximum laden mass:

3. BODYWORK

- 3.1. Full description and/or drawing of the rear underrun protection device (including mounting and fittings):

.....
(Date, file)

▼ **M3***Appendix 3***MODEL**

(maximum format: A4 (210 × 297 mm))

EC TYPE-APPROVAL CERTIFICATE

Stamp of administration

Communication concerning the:

- type-approval⁽¹⁾,
- extension of type-approval⁽¹⁾,
- refusal of type-approval⁽¹⁾,
- withdrawal of type-approval⁽¹⁾,

of a type of vehicle/component/separate technical unit⁽¹⁾ with regard to Directive .../.../EEC as last amended by Directive .../.../EC.

Type-approval number:

Reason for extension:

SECTION I

- 0.1. Make (trade name of manufacturer):
- 0.2. Type and general commercial description(s):
- 0.3. Means of identification of type, if marked on the vehicle/component/separate technical unit⁽¹⁾(²):
.....
- 0.3.1. Location of that marking:
- 0.4. Category of vehicle⁽¹⁾(³):
- 0.5. Name and address of manufacturer:
- 0.7. In the case of components and separate technical units, location and method of affixing of the EC approval mark:
- 0.8. Address(es) of assembly plant(s):

SECTION II

1. Additional information (where applicable): see Addendum
2. Technical service responsible for carrying out the tests:
3. Date of test report:
4. Number of test report:
5. Remarks (if any): see Addendum

▼ **M3**

6. Place:
7. Date:
8. Signature:
9. The index to the information package lodged with the approval authority, which may be obtained on request, is attached.

⁽¹⁾ Delete where not applicable.

⁽²⁾ If the means of identification of type contains characters not relevant to describe the vehicle, component or separate technical unit types covered by this type-approval certificate such characters shall be represented in the documentation by the symbol: '?' (e.g. ABC??123??).

⁽³⁾ As defined in Annex II Section A to Directive 70/156/EEC.

*Addendum to EC type-approval certificate No ...
concerning the type-approval of a vehicle with respect of a rear underrun protective device
(Directive 70/221/EEC as last amended by Directive .../.../EC)*

1. Additional information
 - 1.1. Vehicle category:
 - 1.2. The vehicle is not fitted with a rear underrun protection device⁽¹⁾
 - 1.3. The vehicle is fitted with a rear underrun protection device⁽¹⁾
 - 1.3.1. The device has been approved as a separate technical unit⁽¹⁾
 - distance from the ground and from the rear of the vehicle:
 - approval mark:
 - 1.3.2. The device has not been approved as a separate technical unit⁽¹⁾
 - width, section depth, distance from the ground and from the rear of the vehicle:
 - method of affixing:
5. Remarks:

⁽¹⁾ Delete where not applicable.

▼ **M3***Appendix 4***MODEL**

(maximum format: A4 (210 × 297 mm))

EC TYPE-APPROVAL CERTIFICATE

Stamp of administration

Communication concerning the

- type-approval⁽¹⁾,
- extension of type-approval⁽¹⁾,
- refusal of type-approval⁽¹⁾,
- withdrawal of type-approval⁽¹⁾,

of a type of vehicle/component/separate technical unit⁽¹⁾ with regard to Directive .../.../EEC as last amended by Directive .../.../EC.

Type-approval number:

Reason for extension:

SECTION I

- 0.1. Make (trade name of manufacturer):
- 0.2. Type and general commercial description(s):
- 0.3. Means of identification of type, if marked on the vehicle/component/separate technical unit⁽¹⁾⁽²⁾:
.....
- 0.3.1. Location of that marking:
- 0.4. Category of vehicle⁽¹⁾⁽³⁾:
- 0.5. Name and address of manufacturer:
- 0.7. In the case of components and separate technical units, location and method of affixing of the EC approval mark:
- 0.8. Address(es) of assembly plant(s):

SECTION II

1. Additional information (where applicable): see Addendum
2. Technical service responsible for carrying out the tests:
3. Date of test report:
4. Number of test report:
5. Remarks (if any): see Addendum

▼ **M3**

6. Place:
7. Date:
8. Signature:
9. The index to the information package lodged with the approval authority, which may be obtained on request, is attached.

⁽¹⁾ Delete where not applicable.

⁽²⁾ If the means of identification of type contains characters not relevant to describe the vehicle, component or separate technical unit types covered by this type-approval certificate such characters shall be represented in the documentation by the symbol '?' (e.g. ABC??123??).

⁽³⁾ As defined in Annex II Section A to Directive 70/156/EEC.

*Addendum to EC type-approval certificate No ...
concerning the type-approval of a separate technical unit with regard to a rear underrun protective device
(Directive 70/221/EEC as last amended by Directive .../.../EC)*

1. Additional information
 - 1.1. Construction
 - 1.1.1. Material:
 - 1.1.2. Method of affixing:
 - 1.1.3. Dimension of the device:
 - 1.2. Maximum technically permissible mass of the vehicle on which the device is to be mounted:
 - 1.3. Restrictions of the use of the device (if any):
5. Remarks:

▼ **M3**

Appendix 5

Model for the EC type-approval mark

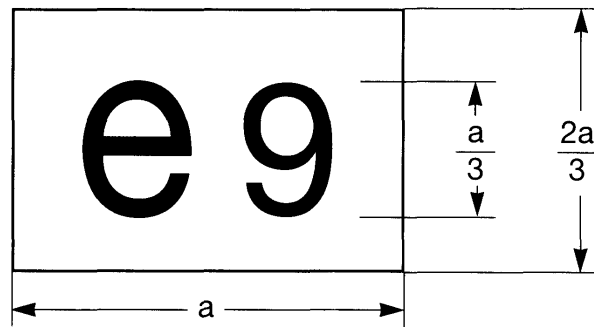
 $a \geq 12 \text{ mm}$ 

000148 $\frac{a}{3}$

The rear underrun protective device bearing the above EC type-approval mark is a device which has been approved in Spain (e 9) under the base approval 0148 on the basis of this Directive (00).

The figures used are only indicative.