

This document is meant purely as a documentation tool and the institutions do not assume any liability for its contents

► **B**

COUNCIL DIRECTIVE

of 27 July 1970

on the approximation of the laws of the Member States relating to the doors of motor vehicles and their trailers

(70/387/EEC)

(OJ L 176, 10.8.1970, p. 5)

Amended by:

	Official Journal		
	No	page	date
► <u>M1</u> Commission Directive 98/90/EC of 30 November 1998	L 337	29	12.12.1998
► <u>M2</u> Commission Directive 2001/31/EC of 8 May 2001	L 130	33	12.5.2001

Amended by:

► <u>A1</u> Act of Accession of Denmark, Ireland and the United Kingdom of Great Britain and Northern Ireland	L 73	14	27.3.1972
--	------	----	-----------

Corrected by:

► <u>C1</u> Consolidated text of corrigenda to instruments published in Special Edition 1952-72, p. 76 (70/387/EEC)			
--	--	--	--

▼B**COUNCIL DIRECTIVE****of 27 July 1970****on the approximation of the laws of the Member States relating to
the doors of motor vehicles and their trailers**

(70/387/EEC)

THE COUNCIL OF THE EUROPEAN COMMUNITIES,

▼C1

Having regard to the Treaty establishing the European Economic Community, and in particular Article 100 thereof;

▼B

Having regard to the proposal from the Commission;

Having regard to the Opinion of the European Parliament;

Having regard to the Opinion of the Economic and Social Committee;

Whereas the technical requirements which motor vehicles must satisfy pursuant to national laws relate, *inter alia*, to their doors;

Whereas those requirements differ from one Member State to another; whereas it is therefore necessary that all Member States adopt the same requirements either in addition to or in place of their existing rules, in order, in particular, to allow the EEC type approval procedure which was the subject of the Council Directive⁽¹⁾ of 6 February 1970 on the approximation of the laws of the Member States relating to the type approval of motor vehicles and their trailers to be applied in respect of each type of vehicle;

HAS ADOPTED THIS DIRECTIVE:

Article 1

For the purposes of this Directive 'vehicle' means any motor vehicle intended for use on the road, having at least four wheels and a maximum design speed exceeding 25 km/h, and its trailers, with the exception of public transport vehicles, vehicles which run on rails, ►M1 agricultural and forestry tractors ◀ and ►M1 all mobile machinery ◀.

Article 2

No Member State may refuse to grant EEC type approval or national type approval of a vehicle on grounds relating to its doors if these satisfy the requirements set out in the Annexes.

▼A1*Article 2a*

No Member State may refuse or prohibit the sale or registration, entry into service or use of a vehicle on grounds relating to its doors if these satisfy the requirements set out in the Annexes.

▼B*Article 3*

The amendments necessary for adjusting the requirements of the Annex so as to take account of technical progress shall be adopted in accordance with the procedure laid down in Article 13 of the Council Directive of 6 February 1970 on the approximation of the laws of the Member States relating to the type approval of motor vehicles and their trailers.

(1) OJ No L 42, 23.2.1970, p. 1.

▼B

Article 4

1. Member States shall put into force the provisions containing the requirements needed in order to comply with this Directive within eighteen months of its notification and shall inform the Commission forthwith.
2. Member States shall communicate to the Commission the text of the main provisions of national law which they adopt in the field covered by this Directive.

Article 5

This Directive is addressed to the Member States.

▼M1*LIST OF ANNEXES*

1. *ANNEX I:* Scope, definitions, general requirements, application for EC type-approval, granting of EC type-approval, modifications of the type and amendments to approvals, conformity of production
Appendix 1: Information document
Appendix 2: Type-approval certificate
2. *ANNEX II:* Construction and fitting requirements and strength tests
3. *ANNEX III:* Requirements concerning access to and exit from doors of driver's compartment

▼ **M1***ANNEX I***SCOPE, DEFINITIONS, GENERAL REQUIREMENTS, APPLICATION FOR EC TYPE-APPROVAL, GRANTING OF EC TYPE-APPROVAL, MODIFICATIONS OF THE TYPE AND AMENDMENTS TO APPROVALS, CONFORMITY OF PRODUCTION**

1. SCOPE

- 1.1. This Directive applies to the doors of motor vehicles of categories M₁ and N⁽¹⁾.

2. DEFINITIONS

For the purpose of this Directive:

- 2.1. 'approval of a vehicle', means the approval of a vehicle type with regard to its doors and to the characteristics applicable to such doors;
- 2.2. 'vehicle type', means vehicles which do not differ essentially with respect to the following main characteristics:
- design and strength characteristics of the latches and hinges as regards the vehicles mentioned in Annex II,
 - construction and fitting requirements of the running boards and steps as regards vehicles not covered by Annex III,
 - position and geometrical characteristics of the access steps and the handholds as regards vehicles mentioned in Annex III,

in so far as these characteristics have a bearing on the requirements of this Directive.

3. GENERAL REQUIREMENTS

3.1. Design

- 3.1.1. The design characteristics of the vehicle must permit entry to and exit from it in perfect safety.
- 3.1.2. Vehicles of category N₂ with a maximum mass exceeding 7,5 tonnes and N₃ are deemed to satisfy the abovementioned requirements if they comply with the prescriptions of Annex III.

3.2. Doors, entries and exits

- 3.2.1. Doors, entries and exits must be such that they can be used easily and without danger.

3.3. Doors and latches

- 3.3.1. Doors and latches must be designed in such a way that any irritating noise on closing may be avoided.
- 3.3.2. Door latches must be designed in such a way as to prevent the doors from opening accidentally.

3.4. Latches and hinges (construction and fitting requirements)

- 3.4.1. The hinges of hinge-mounted doors (with the exception of folding doors), when fitted to the sides of the vehicles, must be fixed at the front edge of the doors in the direction of forward travel. In the case of double doors, these requirements apply to the door wing which opens first; it must be possible to bolt the other wing of the door.
- 3.4.2. The latches and hinges of the side doors of vehicles of category M₁ must satisfy the requirements set out in Annex II to this Directive.

3.5. Running boards and steps (construction and fitting requirements)

- 3.5.1. The wheel hub, rims and other parts of the wheel shall not be deemed to be running boards or steps for the purpose of this Directive, except where reasons relating to construction or use preclude the fitting of running boards or steps elsewhere on the vehicle.

(1) As defined in Annex IIA to Directive 70/156/EEC.

▼M1

- 3.5.2. In vehicles of categories M₁, N₁ and N₂ with a maximum mass not exceeding 7,5 tonnes if the floor entrance to the passenger compartment of such vehicles is more than 600 mm above the ground, the vehicle must have one or more running boards or steps.
 - 3.5.2.1. However, for off-road vehicles, as defined in Annex IIA to Directive 70/156/EEC, such a distance from the ground may be increased up to 700 mm.
 - 3.5.2.2. The running boards or steps must be constructed in such a way as to preclude the risk of slipping.
4. APPLICATION FOR EC TYPE-APPROVAL
 - 4.1. The application for EC type-approval of a vehicle type with respect to the doors shall be submitted by the vehicle manufacturer.
 - 4.2. A model for the information document is given in Appendix 1.
 - 4.3. A vehicle representative of the type to be approved must be submitted to the technical service responsible for type-approval tests.
5. GRANTING OF EC TYPE-APPROVAL
 - 5.1. If the relevant requirements are satisfied, EC type-approval pursuant to Article 4(3) of Directive 70/156/EEC shall be granted.
 - 5.2. A model for the EC type-approval certificate is given in Appendix 2.
 - 5.3. An approval number in accordance with Annex VII to Directive 70/156/EEC shall be assigned to each type of vehicle approved. The same Member State shall not assign the same number to another type of vehicle.
6. MODIFICATIONS OF THE TYPE AND AMENDMENTS TO APPROVALS
 - 6.1. In the case of modifications of the type approved pursuant to this Directive, the provisions of Article 5 of Directive 70/156/EEC shall apply.
7. CONFORMITY OF PRODUCTION
 - 7.1. Measures to ensure the conformity of production shall be taken in accordance with the provisions laid down in Article 10 of Directive 70/156/EEC.

▼ **M1***Appendix 1***INFORMATION DOCUMENT No...**

pursuant to Annex I to Council Directive 70/156/EEC (*) relating to EEC type-approval of a vehicle with respect to the doors (Directive 70/387/EEC, as amended by Directive .../.../EC)

The following information, if applicable, must be supplied in triplicate and include a list of contents.

Any drawings must be supplied in appropriate scale and in sufficient detail on size A4 or folder of A4 format. Photographs, if any, must show sufficient detail.

If the systems, components or separate technical units have electronic controls, information concerning their performance must be supplied.

- 0. GENERAL
 - 0.1. Make (trade name of manufacturer):
 - 0.2. Type:
 - 0.3. Means of identification of type, if marked on the vehicle (b):
 - 0.3.1. Location of that marking:
 - 0.4. Category of vehicle (c):
 - 0.5. Name and address of manufacturer:
 - 0.8. Address(es) of assembly plant(s):
- 1. GENERAL CONSTRUCTION CHARACTERISTICS OF THE VEHICLE
 - 1.1. Photographs and/or drawings of a representative vehicle:
- 9. BODYWORK
 - 9.2. Materials used and methods of construction:
 - 9.3. Occupant doors, latches and hinges:
 - 9.3.1. Door configuration and number of doors:
 - 9.3.1.1. Dimensions, direction and maximum angle of opening:
 - 9.3.2. Drawing of latches and hinges and of their position in the doors:
 - 9.3.3. Technical description of latches and hinges:
 - 9.3.4. Details (including dimensions) of entrances, steps and necessary handles where applicable:

(*) The item numbers and footnotes used in this information document correspond to those set out in Annex I to Directive 70/156/EEC. Items not relevant for the purpose of this Directive are omitted.

▼ **M1****Additional information in the case of off-road vehicles**

- 1.3. Number of axles and wheels:
- 1.3.3. Powered axles (number, position, interconnection):
- 2.4.1. For chassis without bodywork
- 2.4.1.4.1. Approach angle (na):
- 2.4.1.5.1. Departure angle (nb):
- 2.4.1.6. Ground clearance (as defined in paragraph 4.5 of section A of Annex II to Directive 70/156/EEC):
- 2.4.1.6.1. between the axles:
- 2.4.1.6.2. under the front axle(s):
- 2.4.1.6.3. under the rear axle(s):
- 2.4.1.7. Ramp angle (nc):
- 2.4.2. For chassis with bodywork
- 2.4.2.4.1. Approach angle (na):
- 2.4.2.5.1. Departure angle (nb):
- 2.4.2.6. Ground clearance (as defined in paragraph 4.5 of section A of Annex II to Directive 70/156/EEC):
- 2.4.2.6.1. between the axles:
- 2.4.2.6.2. under the front axle(s):
- 2.4.2.6.3. under the rear axle(s):
- 2.4.2.7. Ramp angle (nc):
- 2.15. Hill-starting ability (solo vehicle):
- 4.9. Differential lock: yes/no/optional (!)

(!) Delete where not applicable.

▼ **M1***Appendix 2***MODEL**

(maximum format: A4 (210 × 297 mm))

EC TYPE-APPROVAL CERTIFICATE

Stamp of administration

Communication concerning the

- type-approval ⁽¹⁾
- extension of type-approval ⁽¹⁾
- refusal of type-approval ⁽¹⁾
- withdrawal of type-approval ⁽¹⁾

of a type of a vehicle/component/separate technical unit ⁽¹⁾ with regard to Directive 70/387/EEC, as amended by Directive .../.../EC.

Type-approval number:

Reason for extension:

SECTION I

- 0.1. Make (trade name of manufacturer):
- 0.2. Type:
- 0.3. Means of identification of type if marked on the vehicle/component/separate technical unit ⁽¹⁾ ⁽²⁾:
- 0.3.1. Location of that marking:
- 0.4. Category of vehicle ⁽¹⁾ ⁽³⁾:
- 0.5. Name and address of manufacturer:
- 0.7. In the case of components and separate technical units, location and method of the affixing of the EEC approval mark:
- 0.8. Address(es) of assembly plant(s):

⁽¹⁾ Delete where not applicable.⁽²⁾ If the means of identification of type contains characters not relevant to describe the vehicle, component or separate technical unit types covered by this type-approval certificate such characters shall be represented in the documentation by the symbol '?' (e.g. ABC??123??).⁽³⁾ As defined in Annex IIA to Directive 70/156/EEC.

▼ M1

SECTION II

1. Additional information (where applicable): See Addendum
2. Technical service responsible for carrying out the tests:
3. Date of test report:
4. Number of test report:
5. Remarks (if any): See Addendum
6. Place:
7. Date:
8. Signature:
9. The index to the information package lodged with the approval authority, which may be obtained on request, is attached.

Addendum to EC type-approval certificate No...

concerning the type approval of a vehicle with regard to Directive 70/387/EEC as amended by Directive .../.../EC

1. Additional information
 - 1.1. Occupant door configuration(s):
 - 1.2. Method of opening:
 - 1.3. Latch-opening method:
5. Remarks:

▼B

ANNEX II

CONSTRUCTION AND FITTING REQUIREMENTS AND STRENGTH TESTS FOR ►C1 LATCHES ◀ AND HINGES ON SIDE DOORS FOR ENTRY TO OR EXIT FROM ►M1 VEHICLES OF CATEGORY M₁ ◀

1. GENERAL
 - 1.1 Latches and hinges must be so designed, constructed and fitted that in normal use, the vehicle satisfies the requirements of this ►M1 Annex ◀.
 - 1.2 Each latch shall have both an intermediate latched position and a fully latched position.
2. PARTICULARS AND BATCHES OF LATCHES AND HINGES TO BE SUBMITTED BY THE MANUFACTURER OR HIS AUTHORISED REPRESENTATIVE.

The manufacturer or his authorised representative must submit the following particulars and batches of latches and hinges:

 - 2.1 Drawings of the doors and of their latches and hinges on an appropriate scale and in sufficient detail;
 - 2.2 A technical description of the latches and hinges;
 - 2.3 A batch of five sets of hinges per door. Where, however, the same sets are used for several doors, it will be sufficient to submit one batch of sets. Sets of hinges which are distinguishable only because they are designed to be fitted on the left or on the right shall not be regarded as different;
 - 2.4 A batch of five complete latches, including actuating mechanism, per door. Where, however, the same complete latches are used for several doors, it will be sufficient to submit one batch of such latches. Latches which are distinguishable only because they are designed to be fitted on the left or on the right shall not be regarded as different.
3. CONSTRUCTION REQUIREMENTS
 - 3.1 **Latches**
 - 3.1.1 *Longitudinal load*

The latch and striker assembly shall be able to withstand a longitudinal load of 453 kp (444 daN) in the intermediate latched position and 1134 kp (1111 daN) in the fully latched position (Figure 2).
 - 3.1.2 *Transverse load*

The latch and striker assembly must be capable of withstanding a transverse load of 453 kp (444 daN) in the intermediate latched position, and 907 kp (889 daN) in the fully latched position (Figure 3).
 - 3.1.3 *Resistance to inertia load*

The latch shall not move from the fully latched position when a longitudinal or transverse inertia load, in both directions, of 30 g is applied to the lock assembly, including its actuating mechanism.
 - 3.2 **Hinges**
 - 3.2.1 Each hinge system shall be capable of supporting the door and withstanding a longitudinal load of 1134 kp (1111 daN) and a transverse load of 907 kp (889 daN) in both directions.
4. REQUIREMENTS FOR TESTING THE STRENGTH OF DOOR ►C1 LATCHES ◀ AND HINGES

Compliance with the requirements contained in items 3.1 and 3.2 shall be checked in accordance with the following:

 - 4.1 **Setting up, procedure and equipment for static-load tests**

▼B4.1.1 *Setting up*

4.1.1.1 Hinges

4.1.1.1.1 The tests shall be conducted with the use of rigid components reproducing the geometric conditions of the mounting on the vehicle of a fully latched door.

4.1.1.1.2 To this equipment there shall be applied, at the mid-point between the hinges:

4.1.1.1.2.1 the prescribed longitudinal load, perpendicular to the axis of the hinge pivots, situated in a plane passing through that axis;

4.1.1.1.2.2 the prescribed transverse load, perpendicular to the plane defined by the longitudinal load and the axis of the pivots, and situated in a plane passing through that axis.

4.1.1.1.3 A new set of hinges shall be used for each test.

4.1.1.1.4 Figure 1 gives an illustration of a test assembly.

4.1.1.2 Latches

4.1.1.2.1 The tests shall be conducted with the use of rigid components reproducing the mounting on the vehicle of the two latch components, the latch body and the striker.

4.1.1.2.2 The prescribed load shall be applied to this equipment so as not to cause any stress on the latch. In addition, a transverse static load of 90.7 kp (88.9 daN) shall be applied in such a way that it tends to move the latch away from its striker in the direction in which the door opens.

4.1.1.2.3 Figures 2 and 3 give illustrations of a test assembly.

4.1.2 *Test procedure and equipment*

The equipment referred to in items 4.1.1.1 and 4.1.1.2 above shall be mounted on a tensile testing machine with a minimum capacity of 1500 kp (1470 daN). Loads gradually increasing to the values prescribed in items 3.1 and 3.2 shall be applied thereto in such a way that the speed of separation of the retaining devices does not exceed 5 mm/min.

4.2 **Procedure for determining the resistance of latches to acceleration**

4.2.1 Resistance to opening in both directions under a longitudinal and transverse inertia load of 30 g, applied in both cases to the opening knob in the direction in which it is actuated, shall be determined dynamically or analytically (Figure 4), disregarding:

4.2.1.1 Frictional forces.

4.2.1.2 The components of gravity acceleration which tend to keep the latch closed.

4.2.2 Latch locking devices, if any, must not be brought into play.

4.3 **Equivalent test methods**

4.3.1 Equivalent non-destructive test methods are permitted, provided that the results referred to in items 4.1.2 and 4.2 above can be obtained either entirely by means of the substitute test or by calculation from the results of the substitute test. If a method other than that described in items 4.1.2 and 4.2 above is used, its equivalence must be demonstrated.

▼B

Door hinge system — static-load fixture (transverse load)

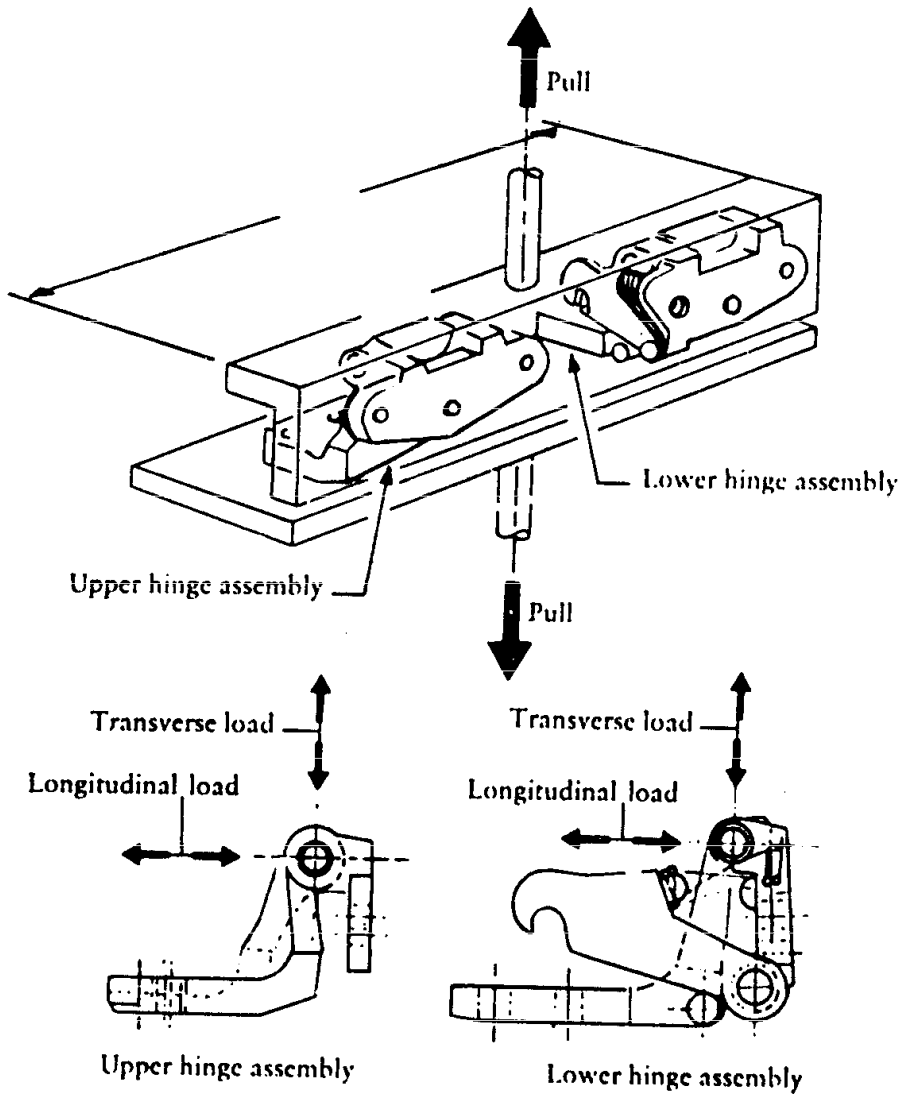

FIGURE 1

▼B

Door latch — Test equipment under static load (longitudinal load)

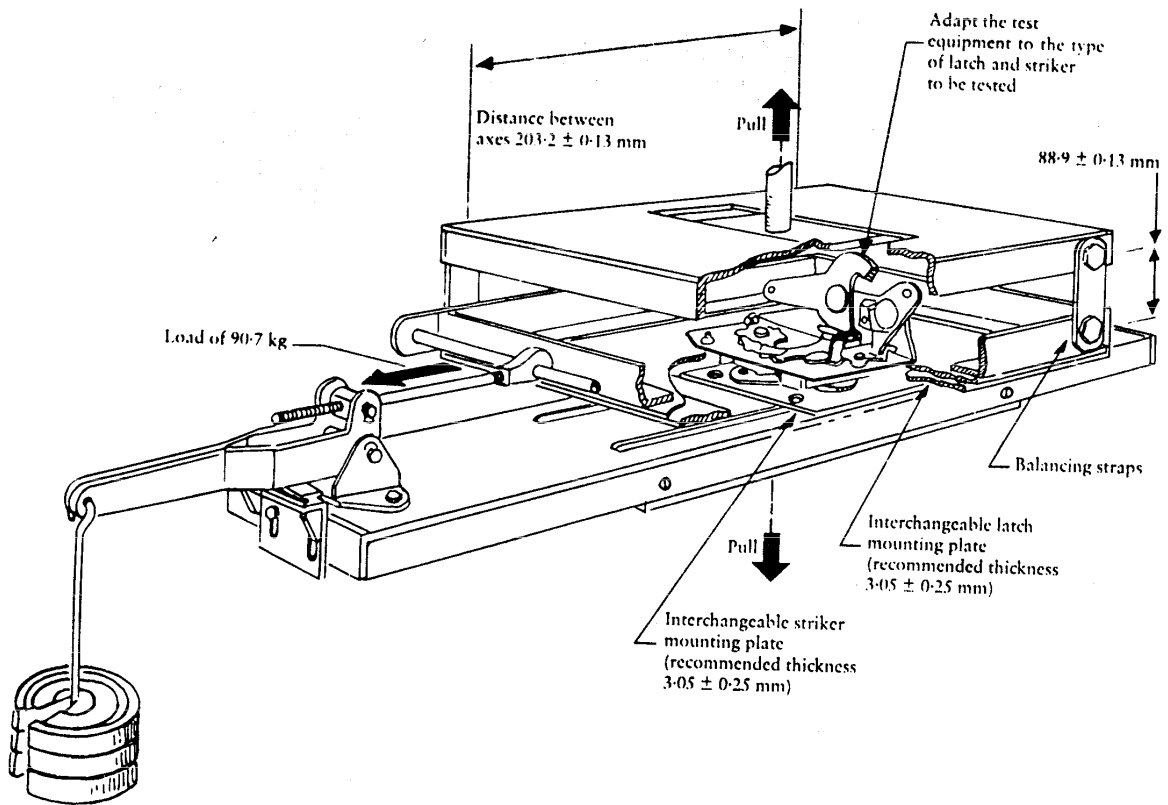

FIGURE 2

Door latch — Test equipment under static load (transverse load)

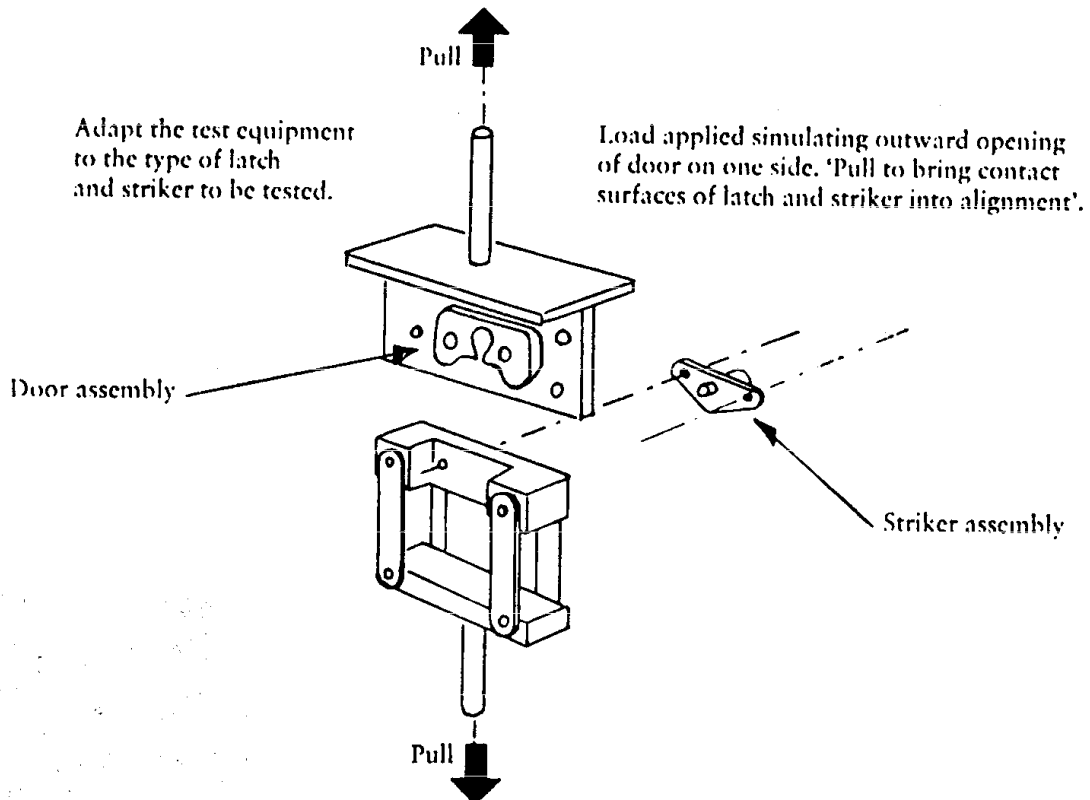

FIGURE 3 ► C1 Door latch assembly ◀

▼B

Resistance to the effects of inertia — Example of calculation

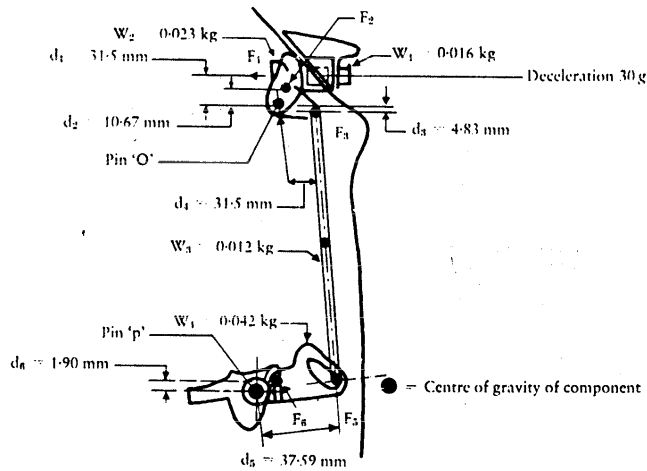

FIGURE 4

Given:

A door latch system subjected to a deceleration of 30 g

$$F = M_a = \frac{W}{g} \quad a = \frac{W}{g} \quad 30 \text{ g} = 30 W$$

$$F_1 = W_1 \times 30 = \text{Average load on knob spring} \\ = (0.016 \text{ kg} \times 30) = 0.454 \text{ kg} = 0.036 \text{ kg}$$

$$F_2 = W_2 \times 30 = 0.023 \text{ kg} \times 30 = 0.68 \text{ kg}$$

$$F_3 = \frac{W_3}{2} \times 30 = \frac{0.012 \text{ kg}}{2} \times 30 = 0.184 \text{ kg}$$

$$\Sigma M_o = F_1 \times d_1 + F_2 \times d_2 - F_3 \times d_3 = 0.036 \text{ kg} \times 31.5 \text{ mm} + 0.68 \text{ kg} \times 10.67 \text{ mm} - 0.184 \text{ kg} \times 4.83 \text{ mm} = 7.51 \text{ mm/kg}$$

$$F_5 = \frac{M_o}{d_4} = \frac{7.51}{31.5} = 0.238 \text{ kg}$$

$$F_6 = W_4 \times 30 = 0.042 \times 30 = 1.265 \text{ kg}$$

$$\Sigma M_p = \text{load on bolt spring } (F_5 d_5 + F_6 d_6) \\ = 45.62 \text{ mm/kg} - (0.238 \times 37.59 + 1.265 \times 1.9) \\ = 45.62 \text{ mm/kg} - 11.36 \text{ mm/kg} = 34.26 \text{ mm/kg}$$

▼ **M1**

ANNEX III

REQUIREMENTS CONCERNING THE ACCESS TO AND EXIT FROM THE DOORS OF THE DRIVER'S COMPARTMENT OF VEHICLES OF CATEGORY N₂ HAVING A MAXIMUM MASS EXCEEDING 7,5 TONNES AND OF CATEGORY N₃

1. Access steps to the driver's compartment (see figure)
 - 1.1. The distance (A) from the ground to the upper surface of the lowest step, measured with the vehicle in running order on a horizontal and flat surface, shall not be more than 600 mm.
 - 1.1.1. However, for off-road vehicles, as defined in Annex IIA to Directive 70/156/EEC, that distance (A) may be increased up to 700 mm.
 - 1.2. The distance (B) between the upper surfaces of the steps shall be not more than 400 mm. The vertical distance between two subsequent steps shall not vary by more than 50 mm. ► **M2** The last requirement shall not apply to the distance between the uppermost step and the cab floor. ◀
 - 1.2.1. However, for off-road vehicles (see 1.1.1), this latter figure may be increased up to 100 mm.
 - 1.3. In addition, the following minimum geometrical specifications shall be fulfilled:

— step depth (D):	80 mm
— step clearance (E) (include step depth):	150 mm
— step width (F):	300 mm
— width of the lowest step (G):	200 mm
— step height (S):	120 mm
— transversal offset between steps (H):	0 mm

▼ **M2**

- | | |
|--|---------|
| — Longitudinal overlap (J) between two subsequent steps in the same flight, or between the uppermost step and the cab floor: | 200 mm. |
|--|---------|

▼ **M1**

- 1.3.1. However, for off-road vehicles (see 1.1.1), the value (F) may be reduced to 200 mm.
 - 1.4. The lowest step may be designed as a rung, if this is necessary for reasons relating to construction or use, and in the case of off-road vehicles (see 1.1.1). In such case the rung depth (R) shall be at least 20 mm.
 - 1.4.1. Rungs of round cross section are not permitted.
 - 1.5. While getting down from the driver's compartment the position of the uppermost step shall be easily found out.
 - 1.6. The upper surface of the steps shall be non-slip. In addition, steps exposed to the weather and the dirt during driving shall have adequate run-off (draining surface).
2. Access to handholds to the driver's compartment (see figure)
 - 2.1. One or more suitable handrails and handholds or other equivalent holding devices shall be provided for the access to the driver's compartment.
 - 2.1.1. The handrail(s) or handholds or equivalent holding devices must be positioned in such a way that they can be easily grasped and do not obstruct access.
 - 2.1.2. A maximum discontinuity of 100 mm in the holding area of the handrails or handholds or equivalent holding devices may be allowed (for instance intermediate fixation).
 - 2.1.3. In the case of access with more than two steps the handrails, handholds or equivalent holding devices shall be located so that a person may support himself at the same time at three points (with two hands and one foot or with two feet and one hand).

▼ **M1**

- 2.1.4. Except in the case of a stairway, the design and positioning of the handrails, handholds and equivalent holding devices must be such that operators are encouraged to descend facing the cab.
- 2.1.5. The steering wheel may be considered as a handhold.
- 2.2. The height (N) of the lower edge of at least one handrail or handhold or equivalent holding device, measured from the ground with the vehicle in running order on a horizontal and flat surface, shall not be more than 1 850 mm.
- 2.2.1. However, for off-road vehicles (see 1.1.1), such distance (N) may be increased up to 1 950 mm.
- 2.2.2. If the floor of the driver's compartment has a height from the ground greater than 'N', this height shall be assumed as 'N'.
- 2.2.3. ► **M2** In addition, the minimum distance (P) of the upper edge of the handrail(s) or handholds or equivalent holding devices from the floor of the driver's compartment shall be: ◀
- handrail(s) or handholds or equivalent holding devices (U) 650 mm,
 - handrail(s) or handholds or equivalent holding devices (V) 550 mm.
- 2.3. The following geometrical specifications shall be fulfilled:
- gripping dimension (K): 16 mm minimum
38 mm maximum,
 - length (M): 150 mm minimum,
 - clearance to vehicle components (L): 40 mm minimum
with open door.

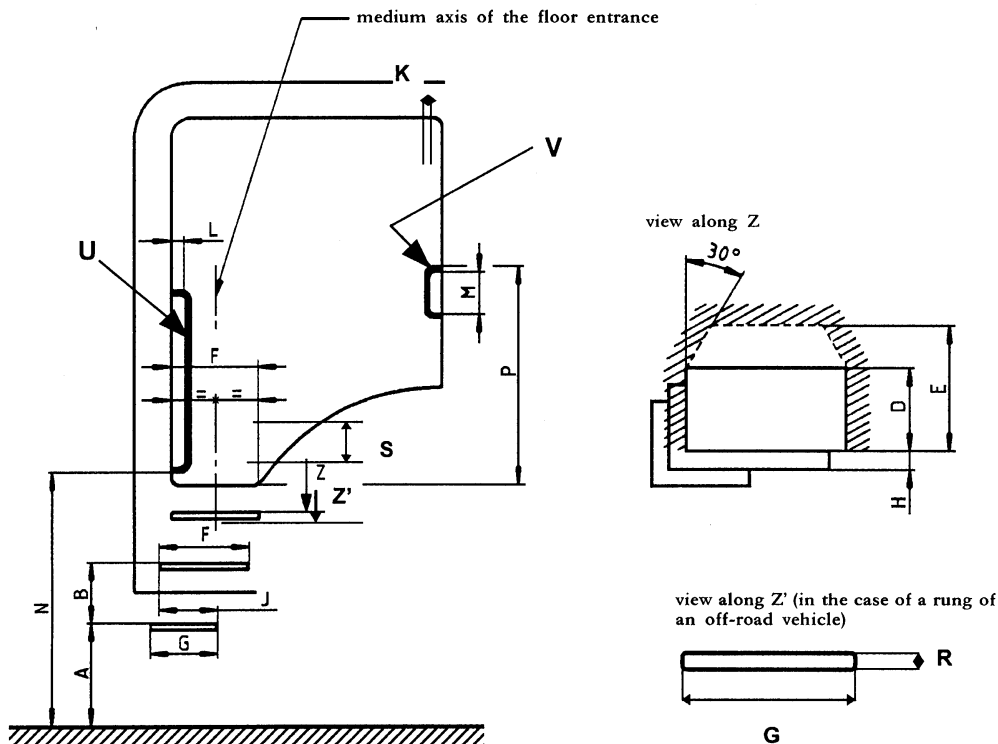

Figure

3. In the case of a sloped floor of the driver's compartment the required measurements shall be made from a horizontal plane passing through a point which is given by the intersection of the front edge of the floor with a vertical plane through the centre of the step immediately below and which is perpendicular to the longitudinal medium plane of the vehicle.