

This document is meant purely as a documentation tool and the institutions do not assume any liability for its contents

► **B**

**COUNCIL DIRECTIVE**

**of 17 December 1973**

**on the approximation of the laws of the Member States relating to devices to prevent the unauthorized use of motor vehicles**

(74/61/EEC)

(OJ L 38, 11.2.1974, p. 22)

Amended by:

		Official Journal		
		No	page	date
► <b><u>M1</u></b>	Commission Directive 95/56/EC of 8 November 1995	L 286	1	29.11.1995
► <b><u>M2</u></b>	Council Directive 2006/96/EC of 20 November 2006	L 363	81	20.12.2006
► <b><u>M3</u></b>	Council Directive 2013/15/EU of 13 May 2013	L 158	172	10.6.2013

Amended by:

► <b><u>A1</u></b>	Act concerning the conditions of accession of the Czech Republic, the Republic of Estonia, the Republic of Cyprus, the Republic of Latvia, the Republic of Lithuania, the Republic of Hungary, the Republic of Malta, the Republic of Poland, the Republic of Slovenia and the Slovak Republic and the adjustments to the Treaties on which the European Union is founded	L 236	33	23.9.2003
--------------------	---	-------	----	-----------

Corrected by:

- **C1** Corrigendum, OJ L 215, 6.8.1974, p. 20 (74/61/EEC)
- **C2** Corrigendum, OJ L 40, 13.2.1998, p. 19 (74/61/EEC)

▼B**COUNCIL DIRECTIVE****of 17 December 1973****on the approximation of the laws of the Member States relating to devices to prevent the unauthorized use of motor vehicles**

(74/61/EEC)

THE COUNCIL OF THE EUROPEAN COMMUNITIES,

Having regard to the Treaty establishing the European Economic Community, and in particular Article 100 thereof;

Having regard to the proposal from the Commission;

Having regard to the Opinion of the European Parliament <sup>(1)</sup>;

Having regard to the Opinion of the Economic and Social Committee <sup>(2)</sup>;

Whereas the technical requirements which motor vehicles must satisfy pursuant to national laws relate, *inter alia*, to devices to prevent the unauthorized use of such vehicles;

Whereas those requirements differ from one Member State to another; whereas it is therefore necessary that all Member States adopt the same requirements, either in addition to or in place of their existing rules, in order in particular to allow the EEC type approval procedure which was the subject of the Council Directive of 6 February 1970 <sup>(3)</sup> on the approximation of the laws of the Member States relating to the type approval of motor vehicles and their trailers to be applied in respect of each type of vehicle;

Whereas as regards the technical requirements it is advisable to follow basically those adopted by the UN Economic Commission for Europe in its Regulation No 18 <sup>(4)</sup> ('Uniform provisions concerning the approval of vehicles with regard to their protection against unauthorized use'), which is annexed to the Agreement of 20 March 1958 concerning the adoption of uniform conditions of approval and reciprocal recognition of approval for motor vehicle equipment and parts,

HAS ADOPTED THIS DIRECTIVE:

*Article 1*

For the purposes of this Directive, 'vehicle' means any motor vehicle intended for use on the road ►**M1**, being complete or incomplete, ◀ having at least four wheels and a maximum design speed exceeding 25 km/h, with the exception of vehicles which run on ►**M1** rails and of agricultural and forestry tractors and all mobile machinery. ◀

<sup>(1)</sup> OJ No C 112, 27. 10. 1972, p. 16.

<sup>(2)</sup> OJ No C 60, 26. 7. 1973, p. 12.

<sup>(3)</sup> OJ No L 42, 23. 2. 1970, p. 1.

<sup>(4)</sup> EEC, Geneva, E/ECE/324 — E/ECE/TRANS/505/Rev. Add. 17.

**▼B***Article 2*

No Member State may refuse to grant EEC type approval or national type approval of a vehicle on grounds relating to the device to prevent unauthorized use if such device meets the requirements set out in ►**M1** the relevant Annexes ◀.

*Article 3*

No Member State may refuse or prohibit the sale, registration, entry into service or use of any vehicle on grounds relating to the device to prevent unauthorized use if such device meets the requirements set out in ►**M1** the relevant Annexes ◀.

*Article 4*

The Member State which has granted type approval shall take the necessary measures to be informed of any modification of a part or characteristic referred to in ►**M1** the relevant Annexes ◀. The competent authorities of that State shall determine whether fresh tests should be carried out on the ►**C1** modified vehicle type ◀ and a fresh report drawn up. Where such tests reveal failure to comply with the requirements of this Directive, the modification shall not be approved.

*Article 5*

The amendments necessary for adjusting the requirements of ►**M1** the Annexes ◀ so as to take account of technical progress shall be adopted in accordance with the procedure laid down in Article 13 of the Council Directive of 6 February 1970 on the harmonization of the laws of the Member States relating to the type-approval of motor vehicles and their trailers.

*Article 6*

1. Member States shall put into force the provisions needed in order to comply with this Directive within eighteen months of its notification and shall forthwith inform the Commission thereof.
2. Member States shall ensure that the texts of the main provisions of national law which they adopt in the field covered by this Directive are communicated to the Commission.

*Article 7*

This Directive is addressed to the Member States.

**▼ M1***LIST OF ANNEXES*

- ANNEX I: Administrative provisions for type-approval  
*Appendix 1:* Model of certificate of conformity
- ANNEX II: Information documents  
*Appendix 1:* Information document for a type of vehicle  
*Appendix 2:* Information for a type of immobilizer  
*Appendix 3:* Information document for a type of vehicle alarm system
- ANNEX III: EEC type-approval certificates  
*Appendix 1:* EEC type-approval certificate for a vehicle  
*Appendix 2:* EEC type-approval certificate for an immobilizer  
*Appendix 3:* EEC type-approval certificate for a vehicle alarm system
- ANNEX IV: Scope, definitions and requirements for devices to prevent unauthorized use  
*Appendix 1:* Wear-producing test procedure for devices to prevent unauthorized use acting on the steering  
*Appendix 2:* Test procedure for devices to prevent unauthorized use acting on the steering using a torque limiting device
- ANNEX V: Scope, definitions and requirements for immobilizers  
*Appendix 1:* Model of installation certificate
- ANNEX VI: Scope, definitions and requirements for vehicle alarm systems  
*Appendix 1:* Model of installation certificate  
*Appendix 2:* Test of systems for the protection of the passenger compartment  
*Appendix 3:* Specifications for mechanical key switches  
*Appendix 4:* Technical prescriptions for audible alarm devices

**▼ M1***ANNEX I***ADMINISTRATIVE PROVISIONS FOR TYPE-APPROVAL**

1. **Application for EEC type-approval of a vehicle**
  - 1.1. The application for EEC type-approval pursuant to Article 3 (4) of Directive 70/156/EEC of a vehicle type with regard to its device to prevent unauthorized use, its immobilizer and, if applicable, its alarm system shall be submitted by the manufacturer.
  - 1.2. A model for the information document is given in Annex II, Appendix 1.
  - 1.3. The following must be submitted to the technical service responsible for conducting the type-approval tests:
    - 1.3.1. A vehicle representative of the type to be approved.
    - 1.3.2. If available, the type-approval certificates of immobilizers/alarm systems installed.
2. **Application for EEC type-approval of a type of vehicle immobilizer**
  - 2.1. The application for EEC type-approval as a component or a separate technical unit pursuant to Article 3 (4) of Directive 70/156/EEC of a type of immobilizer shall be submitted by the manufacturer.
  - 2.2. A model for the information document is given in Annex II, Appendix 2.
  - 2.3. The following must be submitted to the technical service responsible for conducting the type-approval tests:
    - 2.3.1. Three samples of the type of immobilizer to be approved with all its components. Each of the main components must be clearly and indelibly marked with the applicant's trade name or mark and the type designation of that component.
    - 2.3.2. (A) vehicle(s) fitted with the immobilizer to be type approved, chosen by the applicant in agreement with the technical service.
3. **Application for EEC type-approval of a type of vehicle alarm system**
  - 3.1. The application for EEC type-approval as a component or a separate technical unit pursuant to Article 3 (4) of Directive 70/156/EEC of a type of alarm system shall be submitted by the manufacturer.
  - 3.2. A model for the information document is given in Annex II, Appendix 3.
  - 3.3. The following must be submitted to the technical service responsible for conducting the type-approval tests:
    - 3.3.1. Three samples of the type of alarm system to be approved with all its components. Each of the main components must be clearly and indelibly marked with the applicant's trade name or mark and the type designation of that component.
    - 3.3.2. (A) vehicle(s) fitted with the alarm system to be type approved, chosen by the applicant in agreement with the technical service.

**▼ M1**

4. **Granting of EEC type-approval**
- 4.1. If the relevant requirements are satisfied, EEC type-approval pursuant to Article 4 (3) and (4) of Directive 70/156/EEC shall be granted.
- 4.2. A model for the EEC type-approval certificate is given in:
- Annex III, Appendix 1 for applications referred to in item 1.1,
  - Annex III, Appendix 2 for applications referred to in item 2.1,
  - Annex III, Appendix 3 for applications referred to in item 3.1.
- 4.3. An approval number in accordance with Annex VII to Directive 70/156/EEC shall be assigned to each type of vehicle, type of immobilizer or type of alarm system approved. The same Member State shall not assign the same number to another type of vehicle, type of immobilizer or type of alarm system.
5. **EEC type-approval mark**
- 5.1. Every vehicle alarm system and every immobilizer, conforming to a type approved pursuant to this Directive, shall bear an EEC type-approval mark. This mark shall consist of:
- 5.1.1. a rectangle surrounding the lowercase letter 'e' followed by the distinguishing letters or number of the Member State granting the approval:
- '1' Germany
  - '2' France
  - '3' Italy
  - '4' Netherlands
  - '5' Sweden
  - '6' Belgium

**▼ A1**

- '7' Hungary
- '8' the Czech Republic

**▼ M1**

- '9' Spain
- '11' United Kingdom
- '12' Austria
- '13' Luxembourg
- '17' Finland
- '18' Denmark

**▼ M2**

- '19' for Romania

**▼ A1**

- '20' Poland

**▼ M1**

- '21' Portugal
- '23' Greece

**▼ M3**

- '25' for Croatia

▼ A1

- '26' for Slovenia
- '27' for Slovakia
- '29' for Estonia
- '32' for Latvia

▼ M2

- '34' for Bulgaria

▼ A1

- '36' for Lithuania
- 'CY' for Cyprus

▼ M1

- 'IRL' Ireland

▼ A1

- 'MT' for Malta

▼ M1

- 5.1.2. in the vicinity of the rectangle the 'base approval number' contained in Section 4 of the type-approval number referred to in Annex VII to Directive 70/156/EEC, preceded by the two figures indicating the sequence number assigned to the most recent major technical amendment to Directive 74/61/EEC on the date EEC type-approval was granted. In this Directive, the sequence number is 00;
- 5.1.3. the additional symbol 'A' or 'I' or 'AI', indicating if the component or the separate technical unit is a vehicle alarm system or an immobilizer or a combination of both.
- 5.2. Examples of EEC type-approval marks are given below <sup>(1)</sup>:

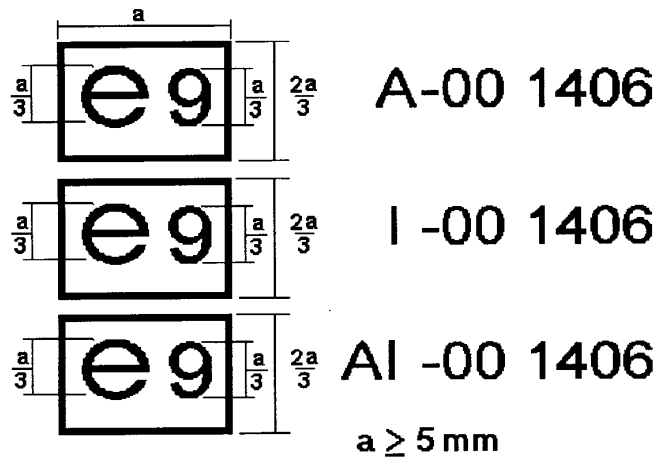

- 5.3. As an alternative to the approval mark described in items 5.1 and 5.2, a certificate of conformity shall be issued for every vehicle alarm system offered for sale.

Where a vehicle alarm system manufacturer supplies an approved unmarked vehicle alarm system to a vehicle manufacturer, for fitment by the manufacturer as original equipment for a vehicle model or range of vehicle models, the vehicle alarm system manufacturer shall supply a number of copies of the certificate of

<sup>(1)</sup> The above approval mark affixed to a vehicle alarm system or to an immobilizer shows that the alarm system (A) or the immobilizer (I) or an alarm system in combination with an immobilizer (AI) has been approved in Spain (e 9), under the base approval number 1406. The first two digits (00) indicate that the approval was granted pursuant to this Directive.

**▼M1**

conformity to the vehicle manufacturer, sufficient for that manufacturer to obtain the vehicle approval to Part II of Annex VI to this Directive.

If the vehicle alarm system is made up of separate components, its main component(s) shall bear a reference mark and the certificate of conformity shall provide a list of such reference marks.

A model of the certificate of conformity is given in Appendix I to this Annex.

6. **Modifications of the type and amendments to approvals**
- 6.1. In the case of modifications of the type of vehicle, type of immobilizer or type of vehicle alarm system approved pursuant to this Directive, the provisions of Article 5 of Directive 70/156/EEC shall apply.
7. **Conformity of production**
- 7.1. Measures to ensure the conformity of production shall be taken in accordance with the provisions laid down in Article 10 of Directive 70/156/EEC.



▼ **M1**

*Appendix 1*

**Model of certificat of conformity**

I the undersigned ..... , testify that the vehicle alarm system described below  
(surname and name)

Make:

Type:

is in total conformity with the type approved at ..... on .....  
(place of approval) (date)

as described in the EEC type-approval certificate bearing approval No .....

Identification of the main component(s):

Component: .....	Marking: .....
.....	.....
.....	.....

Done at: ..... on: .....

Manufacturer's full address and stamp:

Signature: .....  
(specify position)

\_\_\_\_\_

**▼ M1***ANNEX II***INFORMATION DOCUMENTS***Appendix I***Information document No . . .**

in accordance with Annex I to Council Directive 70/156/EEC relating to EEC type-approval of a vehicle type with respect to devices to prevent unauthorized use (\*)

(Directive 74/61/EEC, as last amended by Directive . . . /EC)

The following information, if applicable, must be supplied in triplicate and include a list of contents. Any drawings must be supplied in appropriate scale and in sufficient detail on size A4 or on a folder of A4 format. Photographs, if any, must show sufficient detail.

If the systems, components or separate technical units have electronic controls, information concerning their performance must be supplied.

- 0. **General**
- 0.1. Make (trade name of manufacturer):
- 0.2. Type and general commercial description(s):
- 0.3. Means of identification of type, if marked on the vehicle (b):
- 0.3.1. Location of that marking:
- 0.4. Category of vehicle (c):
- 0.5. Name and address of manufacturer:
- 0.8. Address(es) of assembly plant(s):
- 1. **General construction characteristics of the vehicle**
- 1.1. Photographs and/or drawings of a representative vehicle:
- 12. **Miscellaneous**
- 12.2. Devices to prevent unauthorized use of the vehicle
- 12.2.1. Protective device
- 12.2.1.1. A detailed description of the vehicle type with regard to the arrangement and design of the control or of the unit on which the protective device acts:
- 12.2.1.2. Drawing of the protective device and of its fitting to the vehicle:
- 12.2.1.3. A technical description of the device:
- 12.2.1.4. Details of the lock combination used:
- 12.2.1.5. Vehicle immobilizer
- 12.2.1.5.1. Type-approval number, if available:

(\*) The item numbering and footnotes used in this information document correspond to those contained in Annex I to Directive 70/156/EEC. Items which are not relevant to this Directive are omitted.

**▼ M1**

- 12.2.1.5.2. For immobilizers not yet approved:
  - 12.2.1.5.2.1. A detailed technical description of the vehicle immobilizer and of the measures taken against inadvertent activation:
    - 12.2.1.5.2.2. The system(s) on which the vehicle immobilizer acts:
    - 12.2.1.5.2.3. Number of effective interchangeable codes, if applicable:
  - 12.2.2. Alarm system, if any
    - 12.2.2.1. Type-approval number, if available:
      - 12.2.2.2. For alarm systems not yet approved:
        - 12.2.2.2.1. A detailed description of the alarm system and of the vehicle parts related to the alarm system installed:
          - 12.2.2.2.2. A list of the main components comprising the alarm system:

**▼M1***Appendix 2***Information document No . . .****relating to EEC type-approval as component or separate technical unit of vehicle immobilizers**

(Directive 74/61/EEC, as last amended by Directive . . . /EC)

The following information, if applicable, must be supplied in triplicate and include a list of contents. Any drawings must be supplied in appropriate scale and in sufficient detail on size A4 or on a folder of A4 format. Photographs, if any, must show sufficient detail.

If the systems, components or separate technical units have electronic controls, information concerning their performance must be supplied.

0. **General**
  - 0.1. Make (trade name of manufacturer):
  - 0.2. Type and general commercial description(s):
  - 0.5. Name and address of manufacturer:
  - 0.7. In the case of components and separate technical units, location and method of affixing of the EEC type-approval mark:
  - 0.8. Address(es) of assembly plant(s):
  
1. **Description of the device**
  - 1.1. A detailed technical description of the device including, *inter alia*, the measures taken against inadvertent activation:
  - 1.2. The vehicle systems on which the device acts:
  - 1.3. Method of setting/unsetting the device:
  - 1.4. Number of effective interchangeable codes, if applicable:
  - 1.5. List of main components comprising the device and, if applicable, their reference marks:
  
2. **Drawings**
  - 2.1. Drawings of the main components of the device (the drawings must show the intended space for the EEC type-approval mark or reference mark, as applicable):
  
3. **Instructions**
  - 3.1. List of vehicles to which the device is intended to be fitted:
  - 3.2. Description of the method of installation illustrated by photographs and/or drawings:
  - 3.3. Instructions for use:
  - 3.4. Instructions for maintenance, if any:

**▼M1***Appendix 3***Information document No . . .**

**relating to EEC type-approval as component or separate technical unit of vehicle alarm systems**

(Directive 74/61/EEC, as last amended by Directive . . . /EC)

The following information, if applicable, must be supplied in triplicate and include a list of contents. Any drawings must be supplied in appropriate scale and in sufficient detail on size A4 or on a folder of A4 format. Photographs, if any, must show sufficient detail.

If the systems, components or separate technical units have electronic controls, information concerning their performance must be supplied.

0. **General**
  - 0.1. Make (trade name of manufacturer):
  - 0.2. Type and general commercial description(s):
  - 0.5. Name and address of manufacturer:
  - 0.7. In the case of components and separate technical units, location and method of affixing of the EEC type-approval mark:
  - 0.8. Address(es) of assembly plant(s):
  
1. **Description of the device**
  - 1.1. A detailed technical description of the device including, *inter alia*, the measures taken against false alarms:
  - 1.2. Range of protection offered by the device:
  - 1.3. Method of setting/unsetting the device:
  - 1.4. Number of effective interchangeable codes, if applicable:
  - 1.5. List of main components comprising the device and, if applicable, their reference marks:
  
2. **Drawings**
  - 2.1. Drawings of the main components of the device (the drawings must show the intended space for the EEC type-approval mark or reference mark, as applicable):
  
3. **Instructions**
  - 3.1. List of vehicles to which the device is intended to be fitted:
  - 3.2. Description of the method of installation illustrated by photographs and/or drawings:
  - 3.3. Instructions for use:
  - 3.4. Instructions for maintenance, if any:

▼ **M1**

## ANNEX III

## EEC TYPE-APPROVAL CERTIFICATES

## Appendix I

## MODEL

(maximum format: A4 (210 × 297 mm))

## EEC TYPE-APPROVAL CERTIFICATE

Stamp of administration

Communication concerning the:

- type-approval <sup>(1)</sup>
- extension of type-approval <sup>(1)</sup>
- refusal of type-approval <sup>(1)</sup>
- withdrawal of type-approval <sup>(1)</sup>

of a type of a vehicle/component/separate technical unit <sup>(1)</sup> with regard to Directive . . . /EC, as last amended by Directive . . . /EC.

Type-approval number:

Reason for extension:

## SECTION I

- 0.1. Make (trade name of manufacturer):
- 0.2. Type and general commercial description(s):
- 0.3. Means of identification of type if marked on the vehicle/component/separate technical unit <sup>(1)</sup> <sup>(2)</sup>:
  - 0.3.1. Location of that marking:
- 0.4. Category of vehicle <sup>(3)</sup>:
- 0.5. Name and address of manufacturer:
- 0.7. In the case of components and separate technical units, location and method of affixing of the EEC type-approval mark:
- 0.8. Address(es) of assembly plant(s):

## SECTION II

1. Additional information (where applicable): See addendum
2. Technical service responsible for carrying out the tests:
3. Date of test report:
4. Number of test report:
5. Remarks (is any): See addendum
6. Place:

<sup>(1)</sup> Delete where not applicable.

<sup>(2)</sup> If the means of identification of type contains characters not relevant to describe the vehicle, component or separate technical unit types covered by this type-approval certificate such characters shall be represented in the documentation by the symbol: '?' (e.g. ABC??123??).

<sup>(3)</sup> As defined in Annex II A to Directive 70/156/EEC.

**▼ M1**

7. Date:
8. Signature:
9. The index to the information package lodged with the approval authority, which may be obtained on request, is attached.

*Addendum to EEC type-approval certificate No ...*

concerning the type-approval of a vehicle with regard to Directive 74/61/EEC, as last amended by Directive .../.../EC

1. Additional information
- 1.1. Brief description of the device(s) against unauthorized use and the vehicle parts on which it (they) act(s):
- 1.2. Brief description of the immobilizer:
- 1.3. Brief description of the alarm system, if applicable, including rated supply voltage <sup>(1)</sup>:
5. Remarks

---

<sup>(1)</sup> To be indicated only for vehicle alarm systems (VAS) to be used in vehicles whose rated supply voltage is not 12 volts.

▼ **M1**

## Appendix 2

**MODEL**

(maximum format: A4 (210 × 297 mm))

## EEC TYPE-APPROVAL CERTIFICATE

Stamp of administration

Communication concerning the:

- type-approval <sup>(1)</sup>
- extension of type-approval <sup>(1)</sup>
- refusal of type-approval <sup>(1)</sup>
- withdrawal of type-approval <sup>(1)</sup>

of a type of a vehicle/component/separate technical unit <sup>(1)</sup> with regard to Directive .../.../EC, as last amended by Directive .../.../EC.

Type-approval number:

Reason for extension:

## SECTION I

- 0.1. Make (trade name of manufacturer):
- 0.2. Type and general commercial description(s):
- 0.3. Means of identification of type if marked on the vehicle/component/separate technical unit <sup>(1)</sup> <sup>(2)</sup>:
  - 0.3.1. Location of that marking:
- 0.4. Category of vehicle <sup>(3)</sup>:
- 0.5. Name and address of manufacturer:
- 0.7. In the case of components and separate technical units, location and method of affixing of the EEC type-approval mark:
- 0.8. Address(es) of assembly plant(s):

## SECTION II

1. Additional information (where applicable): See addendum
2. Technical service responsible for carrying out the tests:
3. Date of test report:
4. Number of test report:
5. Remarks (if any): See addendum
6. Place:

<sup>(1)</sup> Delete where not applicable.

<sup>(2)</sup> If the means of identification of type contains characters not relevant to describe the vehicle, component or separate technical unit types covered by this type-approval certificate such characters shall be represented in the documentation by the symbol: '?' (e.g. ABC??123??).

<sup>(3)</sup> As defined in Annex II A to Directive 70/156/EEC.



**▼ M1**

7. Date:
8. Signature:
9. The index to the information package lodged with the approval authority, which may be obtained on request, is attached.

*Addendum to EEC type-approval certificate No . . .*

concerning the type-approval as separate technical unit of a vehicle immobilizer with regard to Directive 74/61/EEC, as last amended by Directive . . . /EC

1. Additional information
  - 1.1. Trade name or mark of the immobilizer:
  - 1.2. Type of immobilizer:
  - 1.3. Brief description of the immobilizer:
  - 1.4. List of vehicles to which the immobilizer is intended to be fitted:
  - 1.5. Types of vehicle on which the immobilizer has been tested:
  - 1.6. List of main components, duly identified, comprising the immobilizer:
5. Remarks

▼ M1

## Appendix 3

MODEL  
(maximum format: A4 (210 × 297 mm))

## EEC TYPE-APPROVAL CERTIFICATE

Stamp of Administration
-------------------------

Communication concerning the:

- type-approval <sup>(1)</sup>
- extension of type-approval <sup>(1)</sup>
- refusal of type-approval <sup>(1)</sup>
- withdrawal of type-approval <sup>(1)</sup>

of a type of a vehicle/component/separate technical unit <sup>(1)</sup> with regard to Directive . . . /EC, as last amended by Directive . . . /EC.

Type-approval number:

Reason for extension:

## SECTION I

- 0.1. Make (trade name of manufacturer):
- 0.2. Type and general commercial description(s):
- 0.3. Means of identification of type if marked on the vehicle/component/separate technical unit <sup>(1)</sup> <sup>(2)</sup>:
  - 0.3.1. Location of that marking:
- 0.4. Category of vehicle <sup>(3)</sup>:
- 0.5. Name and address of manufacturer:
- 0.7. In the case of components and separate technical units, location and method of affixing of the EEC type-approval mark:
- 0.8. Address(es) of assembly plant(s):

## SECTION II

1. Additional information (where applicable): See addendum
2. Technical service responsible for carrying out the tests:
3. Date of test report:
4. Number of test report:
5. Remarks (if any): See addendum
6. Place:

<sup>(1)</sup> Delete where not applicable.

<sup>(2)</sup> If the means of identification of type contains characters not relevant to describe the vehicle, component or separate technical unit types covered by this type-approval certificate such characters shall be represented in the documentation by the symbol: '?' (e.g. ABC??123??).

<sup>(3)</sup> As defined in Annex II A to Directive 70/156/EEC.

**▼ M1**

7. Date:
8. Signature:
9. The index to the information package lodged with the approval authority, which may be obtained on request, is attached.

*Addendum to EEC type-approval certificate No . . .*

concerning the type-approval as separate technical unit of a vehicle alarm system with regard to Directive 74/61/EEC, as last amended by Directive . . . /EC

1. Additional information
  - 1.1. Trade name or mark of the alarm system:
  - 1.2. Type of alarm system:
  - 1.3. Brief description of the alarm system:
  - 1.4. List of vehicles to which the alarm system is intended to be fitted:
  - 1.5. Types of vehicle on which the alarm system has been tested:
  - 1.6. List of main components, duly identified, comprising the alarm system:
  5. Remarks
- \_\_\_\_\_

**▼ M1***ANNEX IV***SCOPE, DEFINITIONS AND REQUIREMENTS FOR DEVICES TO PREVENT UNAUTHORIZED USE****1. Scope**

- 1.1. All vehicles of category M1 and N1 — as defined in Annex II A to Directive 70/156/EEC — must be equipped with a device to prevent unauthorized use that complies with the requirements set out in items 3 and 4.
- 1.2. The fitting of this device to vehicles of other categories is optional, but any such device fitted is required to comply with the provisions of this Annex.

**2. Definitions**

For the purposes of this Annex:

- 2.1. 'vehicle type' means a category of motor vehicles which do not differ in such essential respects as:
  - 2.1.1. the manufacturer's type designation;
  - 2.1.2. the arrangement and design of the vehicle component or components on which the device to prevent unauthorized use acts;
  - 2.1.3. the type of device to prevent unauthorized use;
- 2.2. 'device to prevent unauthorized use' means a system designed to prevent unauthorized normal activation of the engine or other source of main engine power of the vehicle in combination with at least one system which:
  - locks the steering,
  - locks the transmission, or
  - locks the gearshift control;
- 2.3. 'steering' means the steering control, the steering column and its accessory cladding, the steering shaft, the steering gearbox and all other components which directly affect the effectiveness of the device to prevent unauthorized use;
- 2.4. 'combination' means one of the specifically developed and constructed variations of a locking system which, when properly activated, permits operation of the locking system;
- 2.5. 'key' means any device designed and constructed to provide a method of operating a locking system which is designed and constructed to be operated only by that device;
- 2.6. 'rolling code' means an electronic code consisting of several elements the combination of which changes at random after each operation of the transmitting unit.

**▼ M1**

3. **General specifications**
- 3.1. The device to prevent unauthorized use shall be so designed that it is necessary to put it out of action in order to enable:
- 3.1.1. the engine to be started by means of the normal control; and
- 3.1.2. the vehicle to be steered, driven or moved forward under its own power.
- 3.2. The requirements of item 3.1 shall be met by the application of a single key.
- 3.3. Except in the case provided for in item 4.1.5, a system operated with a key inserted in a lock shall not permit removal of the key before the device referred to in item 3.1 has come into action or has been set to act.
- 3.4. The device to prevent unauthorized use referred to in item 3.1, and the vehicle components on which it operates, shall be so designed that it cannot rapidly and without attracting attention be opened, rendered ineffective or destroyed by, for example, the use of low-cost, easily concealed tools, equipment or fabrications readily available to the public at large.
- 3.5. The device to prevent unauthorized use shall be fitted to the vehicle as an item of original equipment (i.e. equipment installed by the vehicle manufacturer prior to first retail sale). It shall be fitted in such a way that even after removal of its housing it cannot, when in the blocked condition, be dismantled otherwise than with special tools. If it were possible to render the device to prevent unauthorized use ineffective by the removal of screws, those screws shall, unless they are of the non-removable type, be covered by parts of the blocked protective device.
- 3.6. Mechanical locking systems shall provide at least 1 000 different key combinations or a number equal to the total number of vehicles manufactured annually if less than 1 000. In vehicles of one type the frequency of occurrence of each combination shall be roughly one per 1 000.
- 3.7. Electrical/electronic locking systems, e.g. remote control, shall have at least 50 000 variants and shall incorporate rolling codes and/or have a minimum scan time of 10 days, e.g. a maximum of 5 000 variants per 24 hours for 50 000 variants minimum.
- 3.8. The key and lock shall not be visibly coded.
- 3.9. The lock shall be so designed, constructed and fitted that turning of the lock cylinder, when in the locked position, with a torque of less than 2,45 Nm is not possible with any key other than the mating key; and
- 3.9.1. for lock cylinders with pin tumblers no more than two identical tumblers operating in the same direction shall be positioned adjacent to each other, and in a lock there shall not be more than 60 % identical tumblers;
- 3.9.2. for lock cylinders with disc tumblers no more than two identical tumblers operating in the same direction shall be positioned adjacent to each other, and in a lock there shall not be more than 50 % identical tumblers.
- 3.10. Devices to prevent unauthorized use shall be such as to exclude any risk of accidental operating failure while the engine is running, particularly in the case of blockage likely to compromise safety.

**▼ M1**

- 3.10.1. It shall not be possible to activate devices to prevent unauthorized use without first setting the engine controls to a stop condition and then performing an action which is not an uninterrupted continuation of stopping the engine.
- 3.10.2. In the case of devices to prevent unauthorized use, if the action of key withdrawal activates the device it shall either necessitate a minimum movement of 2 mm before activation of the device or incorporate an override facility to prevent accidental removal or partial withdrawal of the key.
- 3.11. Power assistance may be used only to activate the locking and/or unlocking action of the device to prevent unauthorized use. The device shall be kept in its operating position by any suitable means which does not need a power supply.
- 3.12. It shall not be possible to activate the motive power of the vehicle by normal means until the device to prevent unauthorized use has been deactivated.
- 3.13. Devices to prevent unauthorized use preventing release of the brakes of the vehicle shall not be permitted.
- 3.14. If the device to prevent unauthorized use is equipped with a driver warning feature it shall be activated when the operator opens the driver's side door, unless the device has been activated and the key removed by the operator.

**4. Particular specification**

In addition to the general specification prescribed in Section 3, the device to prevent unauthorized use shall meet the particular conditions prescribed below:

- 4.1. Devices to prevent unauthorized use acting on the steering
  - 4.1.1. A device to prevent unauthorized use acting on the steering shall render the steering inoperative. Before the engine can be started, the normal steering operation must be restored.
  - 4.1.2. When the device to prevent unauthorized use is set to act, it shall not be possible to prevent the device from functioning.
  - 4.1.3. The device to prevent unauthorized use must continue to meet items 3.10, 4.1.1, 4.1.2 and 4.1.4 after it has undergone 2 500 locking cycles in each direction of the wear producing test specified in Appendix 1.
  - 4.1.4. The device to prevent unauthorized use shall, in its activated position, satisfy one of the following criteria:
    - 4.1.4.1. It shall be strong enough to withstand, without damage to the steering mechanism likely to compromise safety, the application of a torque of 300 Nm about the axis of the steering spindle in both directions under static conditions.
    - 4.1.4.2. It shall incorporate a mechanism designed to yield or slip, such that the system will withstand, either continuously or intermittently, the application of a torque of at least 100 Nm. The locking system must still withstand the application of this torque after the test specified in Appendix 2.
    - 4.1.4.3. It shall incorporate a mechanism designed to permit the steering wheel to rotate freely on the blocked steering spindle. The blocking mechanism shall be strong enough to withstand the application of a torque of 200 Nm about the axis of the steering spindle in both directions under static conditions.

**▼ M1**

- 4.1.5. If the device to prevent unauthorized use is such that the key can be removed in a position other than the position in which the steering is inoperative, it shall be so designed that the manoeuvre required to reach that position and remove the key cannot be effected inadvertently.
- 4.1.6. If a component fails such that the torque requirements specified in 4.1.4.1, 4.1.4.2 and 4.1.4.3 cannot be easily applied, yet the steering system remains blocked, the system shall satisfy the requirements.
- 4.2. Devices acting on the transmission
- 4.2.1. A device to prevent unauthorized use acting on the transmission shall prevent the rotation of the vehicle's driving wheels.
- 4.2.2. When the device to prevent unauthorized use is set to act, it shall not be possible to prevent the device from functioning.
- 4.2.3. It shall not be possible for the transmission to be blocked inadvertently when the key is in the lock of the device to prevent unauthorized use, even if the device preventing starting of the engine has come into action or been set to act.
- 4.2.4. The device to prevent unauthorized use shall be so designed and constructed that it remains fully effective even after some degree of wear as a result of 2 500 locking cycles in each direction.
- 4.2.5. If the device to prevent unauthorized use is such that the key can be removed in a position other than the position in which the transmission is locked, it shall be so designed that the manoeuvre required to reach that position and remove the key cannot be effected inadvertently.
- 4.2.6. The device to prevent unauthorized use shall be strong enough to withstand, without damage likely to compromise safety, the application in both directions and in static conditions of a torque 50 % greater than the maximum torque that can normally be applied to the transmission. In determining the level of this testing torque account shall be taken not of the maximum engine torque, but of the maximum torque that can be transmitted by the clutch or by the automatic transmission.
- 4.3. Devices to prevent unauthorized use acting on the gearshift control
- 4.3.1. A device to prevent unauthorized use acting on the gearshift control shall be capable of preventing any change of gear.
- 4.3.2. In the case of manual gearboxes it must be possible to lock the gearshift lever in reverse only; in addition locking in neutral shall be permitted.
- 4.3.3. In the case of automatic gearboxes provided with a 'parking' position it must be possible to lock the mechanism in the parking position only; in addition locking in neutral and/or reverse shall be permitted.
- 4.3.4. In the case of automatic gearboxes not provided with a 'parking' position it must be possible to lock the mechanism in the following positions only: neutral and/or reverse.
- 4.3.5. The device to prevent unauthorized use shall be so designed and constructed that it remains fully effective even after some degree of wear as a result of 2 500 locking cycles in each direction.

▼ M1

5. **Electromechanical and electronic devices to prevent unauthorized use**

Electromechanical and electronic devices to prevent unauthorized use, where fitted, shall comply with the requirements of items 3 and 4 and item 5 of Annex V, *mutatis mutandis*.



**▼ M1***Appendix 1***Wear-producing test procedure for devices to prevent unauthorized use acting on the steering**

1. **Test equipment**
  - 1.1. The test equipment shall consist of:
    - 1.1.1. a fixture suitable for mounting the sample steering complete with the device to prevent unauthorized use attached, as defined in item 2.2 of Annex IV;
    - 1.1.2. a means for activating and deactivating the device to prevent unauthorized use which shall include the use of the key;
    - 1.1.3. a means for rotating the steering shaft relative to the device to prevent unauthorized use.
  2. **Test method**
    - 2.1. A sample of the steering complete with the device to prevent unauthorized use is attached to the fixture referred to in item 1.1.1.
    - 2.2. One cycle of the test procedure shall consist of the following operations:
      - 2.2.1. Start position. The device to prevent unauthorized use shall be deactivated and the steering shaft shall be rotated to a position which prevents engagement of the device to prevent unauthorized use, unless it is of the type which permits locking in any position of the steering.
      - 2.2.2. Set to activate. The device to prevent unauthorized use shall be moved from the deactivated to the activated position, using the key.
      - 2.2.3. Activated<sup>(1)</sup>. The steering spindle shall be rotated such that the torque on it, at the instant of engagement of the device to prevent unauthorized use, shall be  $40 \text{ Nm} \pm 2 \text{ Nm}$ .
      - 2.2.4. Deactivated. The device to prevent unauthorized use shall be deactivated by the normal means, the torque being reduced to zero to facilitate disengagement.
      - 2.2.5. Return<sup>(1)</sup>. The steering spindle shall be rotated to a position which prevents engagement of the device to prevent unauthorized use.
      - 2.2.6. Opposite rotation. Repeat procedures described in items 2.2.2, 2.2.3, 2.2.4 and 2.2.5, but in the opposite direction of rotation of the steering spindle.
      - 2.2.7. The time interval between two successive engagements of the device shall be at least 10 seconds.
    - 2.3. The wear-producing cycle shall be repeated the number of times specified in item 4.1.3 of Annex IV.

<sup>(1)</sup> If the device to prevent unauthorized use permits locking in any position of the steering, the procedures described in items 2.2.3 and 2.2.5 shall be omitted.

▼ **M1***Appendix 2***Test procedure for devices to prevent unauthorized use acting on the steering using a torque limiting device****1. Test equipment**

1.1. The test equipment shall consist of:

1.1.1. a fixture suitable for holding the relevant parts of a steering system or, if the test is carried out on a complete vehicle, a jacking system capable of lifting all the steered wheels clear of the ground; and

1.1.2. a device or devices capable of producing, and measuring, a torque applied to the steering control as prescribed in item 2.3. The measurement precision must be less than or equal to 2 %.

**2. Test procedure description**

2.1. If the test is carried out on a complete vehicle, the test shall be carried out with all the steered wheels of the vehicle held clear of the ground.

2.2. The steering lock shall be activated such that the steering is blocked.

2.3. A torque shall be applied to the steering control such that it rotates.

2.4. The test cycle includes a rotation of the steering control of 90° followed by a rotation in the opposite direction of 180°, and a new rotation of 90° in the original direction (see figure);

1 cycle = + 90°/- 180°/+ 90° with a tolerance of ± 10 %

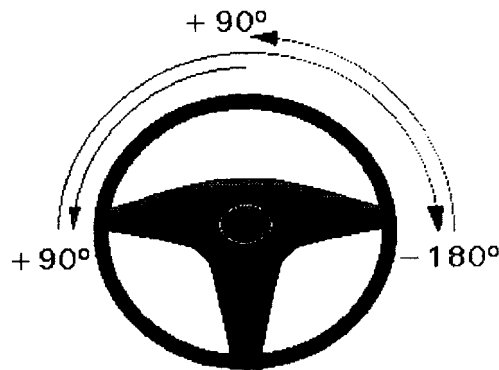

2.5. A cycle duration is equal to 20 s ± 2 s.

2.6. Five test cycles shall be carried out.

2.7. During each of the test cycles the minimum recorded value of the torque shall be higher than that given in item 4.1.4.2 of this Annex.

▼ **M1***ANNEX V***SCOPE, DEFINITION AND REQUIREMENTS FOR IMMOBILIZERS****1. Scope**

- 1.1. All category M1 vehicles must be equipped with an immobilizer.
- 1.2. Immobilizers for fitment to vehicles of other categories is optional, but any such device fitted is required to comply accordingly with the provisions of this Annex, *mutatis mutandis*.

**2. Definitions**

For the purposes of this Directive:

- 2.1. ‘Immobilizer’ means a device which is intended to prevent the driving away of a vehicle powered by its own engine.
- 2.2. ‘Control equipment’ means equipment necessary for the setting and/or unsetting of an immobilizer.
- 2.3. ‘Status display’ means any device intended to indicate the status of the immobilizer (set/unset, change of set to unset and vice versa).
- 2.4. ‘Set state’ means the state in which the vehicle cannot be driven under its own power.
- 2.5. ‘Unset state’ means the state in which the vehicle can be driven normally.
- 2.6. ‘Key’ means any device designed and constructed to provide a method of operating a locking system, which is designed and constructed to be operated only by that device.
- 2.7. ‘Override’ means a design feature which locks the immobilizer in the unset condition.
- 2.8. ‘Type of immobilizer’ means systems which do not differ significantly in such essential aspects as:
  - the manufacturer's trade name or mark,
  - the kind of control equipment,
  - the design of their operation on the relevant vehicle system(s) (as referred to in item 4.1).

**3. General specifications**

- 3.1. It must be possible to set and unset the immobilizer in accordance with these requirements.
- 3.2. If the immobilizer includes the possibility of a radio transmission, e. g. for setting or unsetting, it shall comply with the relevant ETSI standards <sup>(1)</sup>.
- 3.3. An immobilizer and its installation shall be so designed that any equipped vehicle continues to meet the technical requirements.

<sup>(1)</sup> ETSI: European Telecommunications Standards Institute. If these standards are not available when this Directive comes into force, then the relevant domestic requirements shall apply.

**▼ M1**

- 3.4. It shall not be possible for an immobilizer to enter the set state when the ignition key is in the engine running mode.
- 3.5. It shall only be possible to override an immobilizer when it is in the unset condition using a suitable key.
- 3.6. The immobilizer shall be designed and built such that when installed it shall not affect the designed function and operation of the vehicle, even in the case of malfunction.
- 3.7. An immobilizer shall be designed and built such that, when installed on a vehicle, according to the manufacturer's instructions, it cannot rapidly and without attracting attention be rendered ineffective or destroyed by, e. g. the use of low cost easily concealed tools, equipment or fabrications readily available to the public at large. It shall be difficult and time consuming to replace a major component or assembly in order to bypass the immobilizer.
- 3.8. An immobilizer shall be so designed and built such that when installed as specified by the manufacturer it is able to withstand the environment within the vehicle for a reasonable lifetime (for testing see paragraph 5). More particularly the electrical properties of the on-board circuitry shall not be adversely affected by the addition of the immobilizer (lead cross-sections, contact safety, etc.).
- 3.9. An immobilizer may be combined with other vehicle systems or may be integrated into them (e. g. engine management, alarm systems).

**4. Particular specifications**

- 4.1. Extent of disablement
  - 4.1.1. An immobilizer shall be designed so as to prevent the operation of the vehicle under its own power by at least one of the following means:
    - 4.1.1.1. disable at least two separate vehicle circuits that are needed for vehicle operation under its own power (e. g. starter motor, ignition, fuel supply, etc.);
    - 4.1.1.2. interference by code of at least one control unit required for the operation of the vehicle;
  - 4.1.2. An immobilizer for fitment to a vehicle equipped with a catalytic converter shall not cause unburnt fuel to enter the exhaust.
- 4.2. Operating reliability
 

Operating reliability shall be achieved by suitable design of the immobilizer, account being taken of specific environmental conditions in the vehicle (see paragraph 3.8 and 5).
- 4.3. Operating safety
 

It shall be ensured that the immobilizer does not change its state (set/unset) as a result of any of the tests in paragraph 5.
- 4.4. Setting of the immobilizer
  - 4.4.1. The immobilizer must set without supplementary action from the driver by at least one of the following means:
    - at rotation of the ignition key into the '0' position in the ignition lock and activation of a door; in addition, immobilizers which unset immediately before or during the normal starting procedure of the vehicle are permitted to set on turning the ignition off,

**▼ M1**

- a maximum of 5 minutes after removing the key of the ignition lock, or
- when locking the vehicle.

## 4.5. Unsetting

4.5.1. Unsetting shall be achieved by using one or a combination of the following devices. Other devices giving equivalent performance are permitted.

4.5.1.1. A mechanical key, complying with requirements of Appendix 3 to Annex VI.

4.5.1.2. A key pad for inputting an individually selectable code having at least 10 000 variants.

4.5.1.3. Electrical/electronic device, e. g. remote control, with a least 50 000 variants and shall incorporate rolling codes and/or have a minimum scan time of 10 days, e. g. a maximum of 5 000 variants per 24 hours for 50 000 variants minimum.

## 4.6. Status display

4.6.1. To provide information on the status of the immobilizer (set/unset, change of set to unset and vice versa), optical displays inside and outside the passenger compartment are allowed. The light intensity of optical signals installed outside the passenger compartment shall not exceed 0.5 cd.

4.6.2. If an indication of short-term 'dynamic' processes such as changes from 'set' to 'unset' and vice versa is provided, it shall be optical, according to paragraph 4.6.1. Such optical indication may also be produced by the simultaneous operation of the direction indicators and/or passenger compartment lamp(s), provided that the duration of the optical indication by the direction indicators does not exceed 3 seconds.

5. **Operation parameters and test conditions**

## 5.1. Operation parameters

All components of the immobilizer shall comply with prescriptions given in point 5 of Annex VI.

This requirement does not apply to:

- those components that are fitted and tested as part of the vehicle, whether or not an immobilizer is fitted (e. g. lamps); or,
- those components that have previously been tested as part of the vehicle and documentary evidence has been provided.

## 5.2. Test conditions

All the tests shall be carried out in sequence on a single immobilizer. However, at the discretion of the test authority other samples may be used if this is not considered to affect the results of the other tests.

## 5.2.1. Operation test

Upon completion of all the tests specified below, the immobilizer shall be tested under the normal test conditions specified in paragraph 5.2.1.2. of Annex VI to check that it continues to function normally. Where necessary, fuses may be replaced prior to the test.

All components of the immobilizer shall comply with prescriptions given in points 5.2.2 to 5.2.8 and 5.2.12 of Annex VI.

**▼ M1****6. Instructions**

(Items 6.1 to 6.3 for purposes of aftermarket installation only)

Each immobilizer shall be accompanied by:

- 6.1. Instructions for installation
  - 6.1.1. The list of vehicles and vehicle models for which the device is intended. This list may be specific or generic, e. g. 'all cars with petrol engines and 12 V negative earth batteries'.
  - 6.1.2. The method of installation illustrated by photographs and/or very clear drawings.
  - 6.1.3. Detailed installation instructions provided by the supplier shall be such that when correctly followed by a competent installer, the safety and reliability of the vehicle is not affected.
  - 6.1.4. The supplied installation instructions shall identify the electrical power requirements of the immobilizer and, where relevant, shall advise an increasing of battery size.
  - 6.1.5. The supplier shall provide post installation procedures for checking the vehicle. Particular attention shall be drawn to safety related features.
- 6.2. A blank installation certificate, an example of which is given in Appendix 1.
- 6.3. A general statement to the immobilizer purchaser calling his attention to the following points:
  - 6.3.1. — the immobilizer should be installed in accordance with the manufacturer's instructions;
  - 6.3.2. — the selection of a good installer is recommended (the immobilizer manufacturer may be contacted to indicate appropriate installers);
  - 6.3.3. — the installation certificate supplied with the immobilizer should be completed by the installer.
- 6.4. Instructions for use
- 6.5. Instructions for maintenance
- 6.6. A general warning regarding the dangers of making any alterations or additions to the immobilizer; such alterations and additions would automatically invalidate the certificate of installation referred to in paragraph 6.2.

▼ **M1**

*Appendix 1*

**Model of installation certificate**

I, the undersigned, ..... ,  
certify that the installation of the immobilizer described below has been carried out by myself pursuant to  
the fitting instructions supplied by the manufacturer of the system.

Description of the vehicle:

Make:

Type:

Serial Number:

Registration Number:

Description of the immobilizer:

Make:

Type:

Approval Number:

Done at: ..... on: .....

Installer's full address (and stamp, if appropriate):

Signature: .....

Position: .....

\_\_\_\_\_

▼ **M1***ANNEX VI***SCOPE, DEFINITIONS AND REQUIREMENTS FOR VEHICLE ALARM SYSTEMS****1. Scope**

This Annex applies to:

- 1.1. *Part I:* Vehicle alarm systems (VAS) which are intended to be permanently fitted to vehicles of ► **C2** category-M<sub>1</sub> <sup>(1)</sup> and category-N<sub>1</sub> <sup>(1)</sup> vehicles with a technically permissible maximum mass of not more than 2 000 kg <sup>(2)</sup> ◀.
- 1.2. *Part II:* Vehicles of ► **C2** category-M<sub>1</sub> <sup>(1)</sup> and category-N<sub>1</sub> <sup>(1)</sup> vehicles with a technically permissible maximum mass of not more than 2 000 kg ◀ with regard to their alarm system(s) (AS) <sup>(2)</sup>.
- 1.3. If such a system is fitted to vehicles of other categories, then it must comply, *mutatis mutandis*, with the provisions of this Annex.

**PART I****APPROVAL OF VEHICLE ALARM SYSTEM****2. Definitions**

For the purpose of Part I of this Annex

- 2.1. 'Vehicle alarm system' (VAS) means a system intended for installation on (a) type(s) of vehicle(s), designed to indicate intrusion into or interference with the vehicle; these systems may provide additional protection against unauthorized use of the vehicle;
- 2.2. 'Sensor' means a device which senses a change which could be caused by intrusion into or interference with a vehicle;
- 2.3. 'Alarm signal device' means a device indicating that intrusion into or interference has occurred;
- 2.4. 'Control equipment' means equipment necessary for the setting, unsetting and testing of VAS and for sending an alarm condition to warning devices;
- 2.5. 'Set' means the state of a VAS in which an alarm condition can be transmitted to warning devices;
- 2.6. 'Unset' means the state of a VAS in which an alarm condition cannot be transmitted to warning devices;
- 2.7. 'Key' means any device designed and constructed to provide a method of operating a locking system which is designed and constructed to be operated only by that device;
- 2.8. 'Type of vehicle alarm system' means systems which do not differ significantly in such essential aspects as:
  - the manufacturer's trade name or mark,
  - the kind of sensor,
  - the kind of alarm signal device,
  - the kind of control equipment;

<sup>(1)</sup> M1 & N1 as defined in Annex II A to Directive 70/156/EEC.

<sup>(2)</sup> Only vehicles with 12 volts electrical systems are considered.



**▼ M1**

2.9. 'Immobilizer' means a device which is intended to prevent the use of the vehicle powered by its own engine.

2.10. 'Panic Alarm' means a device which enables a person to use an alarm, installed on the vehicle, to summon assistance in an emergency.

3. **General specifications**

3.1. VAS shall, in the event of intrusion into or interference with a vehicle, provide an alarm signal.

The alarm signal shall be audible and in addition may include optical alarm devices, or be a radio alarm or any combination of the above.

3.2. VAS shall be designed, constructed and installed in such a way that the vehicle when equipped shall continue to comply with the relevant technical requirements, especially with regard to electromagnetic compatibility (EMC).

3.3. If the VAS includes the possibility of a radio transmission, e. g. for setting or unsetting of the alarm or for alarm transmission, it shall comply with the relevant ETSI standards. The frequency must be 433,92 MHz and the maximum radiated power 25 mW.

3.4. The installation of a VAS in a vehicle shall not be capable of influencing the vehicle's performance (in the unset state), or its safe operation.

3.5. The VAS and components thereof shall not activate inadvertently, particularly whilst the engine is in its running mode.

3.6. Failure of the VAS, or failure of its electrical supply shall not affect the safe operation of the vehicle.

3.7. The VAS, its components and the parts controlled by them shall be designed, built and installed in such a way as to minimize the risk for anyone to make them inoperative or to destroy them rapidly and without calling attention, e. g. using low-cost, easily-concealed tools, equipment or fabrications readily available to the public at large.

3.8. The means of setting and unsetting of the VAS shall be designed in such a way that it does not invalidate the requirements of Annex IV of this Directive. Electrical connections to components covered by that Annex are allowed.

3.9. The system shall be so arranged that the shorting out of any alarm signal circuit shall not render inoperative any aspects of the alarm system, other than the circuit which is shorted out.

3.10. VAS may include an immobilizer which shall comply with the requirements of Annex V.

4. **Particular specifications**

4.1. Protection range

4.1.1. Specific requirements

The VAS shall at least detect and signal the opening of any vehicle door, engine bonnet and luggage compartment. The failure or switching off of light sources, e. g. passenger compartment light, shall not impair the control operation.

Additional efficient sensors for information/display, e. g. of intrusions into the vehicle, e. g. passenger compartment control, window glass control, breakage of any glazed area, or of attempted vehicle theft, e. g. inclination sensor; are allowed, taking account of measures to prevent any unnecessary sounding of the alarm (= false alarm, see paragraph 4.1.2).

**▼ M1**

In so far as these additional sensors generate an alarm signal even after an intrusion has occurred (e. g. by breakage of a glazed area) or under external influences (e. g. wind), the alarm signal, activated by one of the abovementioned sensors, shall be activated not more than 10 times within the same activation period of the VAS. In this case the activation period shall be limited by the unsetting of the system as a result of the vehicle user's action.

Some kinds of additional sensors, e. g. passenger compartment control (ultrasonic, infra-red) or inclination sensor, etc., may be intentionally deactivated. In this case, separate deliberate action must be taken each time before the VAS is set. It must not be possible to deactivate the sensors while the alarm system is in a set state.

#### 4.1.2. Safety against false alarm.

##### 4.1.2.1. By adequate measures, e. g.:

- mechanical design and design of the electrical circuit according to conditions specific to motor vehicles,
- selection and application of operation and control principles for the alarm system and components thereof,

it shall be ensured that the VAS both in set and unset conditions, cannot cause the alarm signal to sound unnecessarily, in the event of:

- an impact on the vehicle: test specified in item 5.2.13,
- electromagnetic compatibility: tests specified in item 5.2.12,
- reduction of battery voltage by continuous discharge: test specified in item 5.2.14,
- false alarm of the passenger compartment control: test specified in item 5.2.15.

##### 4.1.2.2. If the applicant for approval can demonstrate, e. g. by technical data, that safety against false alarm is satisfactorily ensured, the technical service responsible for conducting approval tests may not require some of the above tests.

#### 4.2. Audible alarm

##### 4.2.1. General

The alarm signal shall be clearly audible and recognizable and shall differ significantly from the other audible signals used in road traffic.

In addition to the original equipment audible warning device, a separate audible alarm signal device may be fitted in the area of the vehicle which is controlled by the VAS, where it shall be protected against easy, rapid access by persons.

If a separate audible alarm signal device according to item 4.2.3.1 is used, the original equipment standard audible warning device may additionally be actuated by the VAS, provided that any tampering with the standard audible warning device (generally more easily accessible) does not affect the operation of the separate audible alarm signal device.

##### 4.2.2. Duration of the audible alarm signal:

Minimum: 25 s

Maximum: 30 s.

**▼ M1**

The audible alarm signal may sound again only after the next interference with the vehicle i. e. after the abovementioned time span (Restrictions: see items 4.1.1 and 4.1.2).

Unsetting of the alarm system shall immediately cut the alarm signal.

#### 4.2.3. Specifications concerning the audible alarm signal.

##### 4.2.3.1. Constant tone alarm signal device (constant frequency spectrum), e. g. horns: acoustical, etc. data according to Appendix 4 of this Annex.

Intermittent alarm signal (on/off):

Trigger frequency  $2 \text{ Hz} \pm 1 \text{ Hz}$

On time = off time  $\pm 10 \%$

##### 4.2.3.2. Audible alarm signal device with frequency modulation: acoustical, etc. data according to Appendix 4 of this Annex, but equal passage of a significant frequency range within the abovementioned range (1 800 through 3 550 Hz) in both directions.

Passage frequency  $2 \text{ Hz} \pm 1 \text{ Hz}$

##### 4.2.3.3. Sound level

The sound source shall be:

- either an audible warning device approved under Directive 70/388/EEC, Section 1 or a device meeting the requirements of items 1 and 2 of Appendix 4 to this Annex,
- however, in the case of a sound source different from the original equipment audible warning device, the minimum sound level may be reduced to 100 dB (A), measured under the conditions of Appendix 4 of this Annex.

#### 4.3. Optical alarm — if fitted

##### 4.3.1. General

In the event of intrusion into or interference with the vehicle, the device shall activate an optical alarm signal as specified in items 4.3.2 and 4.3.3.

##### 4.3.2. Duration of the optical alarm signal

The optical alarm signal shall have a ► **C2** duration of between 25 s ◀ and 5 minutes after the alarm has been activated.

The unsetting of the alarm system shall immediately stop the alarm signal.

##### 4.3.3. Type of optical alarm signal

Flashing of all direction indicators and/or passenger compartment light of the vehicle, including all lamps in the same electrical circuit.

Trigger frequency  $2 \text{ Hz} \pm 1 \text{ Hz}$

In relation to the audible signal, also asynchronous signals are allowed.

On time = off time  $\pm 10 \%$ .

#### 4.4. Radio alarm (pager) — if fitted

The VAS may include a facility generating an alarm signal by radio transmission.

**▼ M1**

- 4.5. Alarm system setting lock
- When the engine is in its running mode, deliberate or inadvertent setting of the alarm system shall be impossible.
- 4.6. Setting and unsetting of the VAS
- 4.6.1. Setting
- Any suitable means of setting of the VAS is allowed, provided that such means does not inadvertently cause false alarms.
- 4.6.2. Unsetting
- Unsetting of the VAS shall be achieved by one or a combination of the following devices: (other devices giving equivalent performance are permitted.)
- 4.6.2.1. — a mechanical key (complying with requirements of Appendix 3 to this Annex) which can be coupled with a centralized vehicle locking system comprising at least 1 000 variants, operated from the outside,
- 4.6.2.2. — electrical/electronic device, e. g. remote control, with at least 50 000 variants which shall incorporate a rolling code and/or have a minimum scan time of 10 days, e. g. a maximum of 5 000 variants per 24 hours for 50 000 variants minimum,
- 4.6.2.3. — a mechanical key or an electrical/electronic device within the protected passenger compartment, with timed exit/entry delay.
- 4.7. Exit delay
- If the switching device for setting the VAS is fitted within the protected area, an exit delay shall be provided. It shall be possible for the exit delay to be set between 15 seconds and 45 seconds after the switch has been operated. The delay period may be adjustable to suit individual operator's circumstances.
- 4.8. Entry delay
- If the switching device for setting the VAS is fitted within the protected area, a delay of 5 seconds minimum and 15 seconds maximum shall be allowed before the activation of the audible and optical alarm signals. The delay period may be adjustable to suit individual operators circumstances.
- 4.9. Status display
- 4.9.1. To provide information on the status of the VAS (set, unset, alarm setting period, alarm has been activated), optical displays inside and outside the passenger compartment are allowed. The light intensity of optical signals installed outside the passenger compartment shall not exceed 0,5 cd.
- 4.9.2. If an indication of short-term 'dynamic' processes such as changes from 'set' to 'unset' and vice versa is provided, it shall be optical, according to item 4.9.1. Such optical indication may also be produced by the simultaneous operation of direction indicators and/or passenger compartment lamp(s), provided that the duration of the optical indication by direction indicators does not exceed 3 seconds.
- 4.10. Power supply
- The source of power for the VAS may be the vehicle battery.
- Where provided, an additional battery shall be rechargeable and it shall by no means supply energy to the other parts of the vehicle's electrical system.

**▼ M1**

- 4.11. Specifications for optional functions
- 4.11.1. Self-check, automatic failure indication
- On setting the VAS, irregular situations, e. g. open doors, etc., may be detected by a self-check function (plausibility control), and this situation may be indicated.
- 4.11.2. Panic alarm
- An optical and/or audible and/or radio alarm is allowed independent of the state (set or unset) and/or function of the VAS. Such an alarm shall be triggered from within the vehicle and shall not affect the state (set or unset) of the VAS. Also it must be possible for the vehicle user to switch off the panic alarm. In the case of an audible alarm, its sounding duration per activation shall not be restricted. A panic alarm shall not immobilize the engine or stop it if it is running.
5. **Operation parameters and test conditions** <sup>(1)</sup>
- 5.1. Operation parameters
- All components of the VAS shall operate without any failure under the following conditions.
- 5.1.1. Climatic conditions
- Two classes of environmental temperature are defined as follows:
- - 40 °C to + 85 °C for parts to be fitted in the passenger or luggage compartment,
  - - 40 °C to + 125 °C for parts to be fitted in the engine compartment unless otherwise specified.
- 5.1.2. Degree of protection for installation
- The following degrees of protection in accordance with IEC publication 529-1989 shall be provided:
- IP 40 for parts to be fitted in the passenger compartment,
  - IP 42 for parts to be fitted in the passenger compartment of roadsters/convertibles and cars with moveable roof-panels if the installation location requires a higher degree of protection than IP 40,
  - IP 54 for all other parts.
- The VAS manufacturer shall specify in the installation instructions any restrictions on the positioning of any part of the installation with respect to dust, water and temperature.
- 5.1.3. Weatherability
- Seven days according to IEC 68-2-30-1980.
- 5.1.4. Electrical conditions
- Rated supply voltage: 12 V
- Operation supply voltage range: from 9 V to 15 V in the temperature range according to item 5.1.1.
- Time allowance for excess voltages at 23 °C:
- U = 18 V, maximum 1 hour,
  - U = 24 V, maximum 1 minute.

<sup>(1)</sup> Lamps which are used as part of the optical alarm devices and which are included in the standard car lighting system need not comply with the operation parameters in item 5.1 and shall not be submitted to tests listed under item 5.2.

**▼ M1**

- 5.2. Test conditions
- 5.2.1. Operation tests
- 5.2.1.1. Compliance of the VAS with the following specifications shall be checked:
- alarm duration according to items 4.2.2 and 4.3.2,
  - frequency and on/off ratio according to items 4.3.3 and 4.2.3.1 or 4.2.3.2 respectively,
  - number of alarm cycles according to item 4.1.1, if applicable,
  - alarm systems setting lock check according to item 4.5.
- 5.2.1.2. Normal test conditions
- Voltage  $U = 12 \text{ V} \pm 0,2 \text{ V}$
- Temperature  $T = 23 \text{ }^\circ\text{C} \pm 5 \text{ }^\circ\text{C}$
- 5.2.2. Resistance to temperature and voltage changes
- Compliance with the specifications defined under item 5.2.1.1 shall also be checked under the following conditions:
- 5.2.2.1. Test temperature  $T = -40 \text{ }^\circ\text{C} \pm 2 \text{ }^\circ\text{C}$
- Test voltage  $U = 9 \text{ V} \pm 0,2 \text{ V}$
- Storage duration 4 hours
- 5.2.2.2. For parts to be fitted in the passenger or luggage compartment
- Test temperature  $T = 85 \text{ }^\circ\text{C} \pm 2 \text{ }^\circ\text{C}$
- Test voltage  $U = 15 \text{ V} \pm 0,2 \text{ V}$
- Storage duration 4 hours
- 5.2.2.3. For parts to be fitted in the engine compartment unless otherwise specified
- Test temperature  $T = 125 \text{ }^\circ\text{C} \pm 2 \text{ }^\circ\text{C}$
- Test voltage  $U = 15 \text{ V} \pm 0,2 \text{ V}$
- Storage duration 4 hours
- 5.2.2.4. The VAS, in both set and unset state, shall be submitted to an excess voltage equal to  $18 \text{ V} \pm 0,2 \text{ V}$  for 1 hour.
- 5.2.2.5. The VAS, in both set and unset state, shall be submitted to an excess voltage equal to  $24 \text{ V} \pm 0,2 \text{ V}$  for 1 minute.
- 5.2.3. Safe operation after foreign body and water-tightness testing
- After the test for tightness for foreign body and water according to IEC 529-1989, for degrees of protection as in item 5.1.2, the operation tests according to item 5.2.1 shall be repeated.
- 5.2.4. Safe operation after condensed water test
- After a resistance-to-humidity test to be carried out according to IEC 68-2-30-1980 the operation tests according to item 5.2.1 shall be repeated.
- 5.2.5. Test for safety against reversed polarity
- The VAS and components thereof shall not be destroyed by reversed polarity up to 13 V during 2 minutes.
- After this test the operation tests according to item 5.2.1 shall be repeated.

**▼ M1**

- 5.2.6. Test for safety against short-circuits
- All electrical connections of the VAS must be short-circuit proof against earth, maximum 13 V and/or fused.
- After this test the operation tests according to item 5.2.1 shall be repeated, with fuses changed if necessary.
- 5.2.7. Energy consumption in the set condition
- The energy consumption in set condition under the conditions given in item 5.2.1.2 shall not exceed 20 mA for the complete alarm system including status display and immobilizer, if fitted.
- 5.2.8. Safe operation after vibration test
- 5.2.8.1. For this test, the components are subdivided into two types:
- Type 1: components normally mounted on the vehicle;
- Type 2: components intended for attachment to the engine.
- 5.2.8.2. The components/VAS shall be submitted to a sinusoidal vibration mode whose characteristics are as follows:
- 5.2.8.2.1. For type 1
- The frequency shall be variable from 10 Hz to 500 Hz with a maximum amplitude of  $\pm 5$  mm and maximum acceleration of 3 g (0-peak).
- 5.2.8.2.2. For type 2
- The frequency shall be variable from 20 Hz to 300 Hz with a maximum amplitude of  $\pm 2$  mm and maximum acceleration of 15 g (0-peak).
- 5.2.8.2.3. For both type 1 and type 2:
- the frequency variation is 1 octave/min;
- The number of cycles is 10, the test shall be performed along each of the 3 axes;
- the vibrations are applied at low frequencies at a maximum constant amplitude and at a maximum constant acceleration at high frequencies.
- 5.2.8.3. During the test the VAS shall be electrically connected and the cable shall be supported after 200 mm.
- 5.2.8.4. After the vibration test the operation test according to item 5.2.1 shall be repeated.
- 5.2.9. Durability test
- Under the test conditions specified in item 5.2.1.2, triggering of 300 complete alarm cycles (audible and/or optical) with a rest time of the audible device of 5 minutes.
- 5.2.10. Tests for external key switch (installed on the outside of the vehicle)
- The following tests shall only be performed if the locking cylinder of the original equipment door lock is not used.
- 5.2.10.1. The key switch shall be so designed and constructed that it remains fully effective even after:
- 2 500 set/unset cycles in each direction, followed by,
  - 96 hours minimum of exposure to salt spray test according to IEC 68-2-11-1981, corrosion resistance test.
- 5.2.11. Test of systems for the protection of the passenger compartment
- The alarm shall be activated, when a vertical panel of  $0,2 \times 0,15$  m is inserted for 0,3 m (measured from the centre of the vertical panel) through an open front door window into the passenger compartment, towards the front and parallel to the road at a speed of 0,4 m/s and at an angle of  $45^\circ$  with the longitudinal median plane of the vehicle. (See drawings in Appendix 2 to this Annex).

**▼ M1**

- 5.2.12. Electromagnetic compatibility
- Vehicle alarm systems shall comply with the relevant technical requirements, especially with regard to electromagnetic compatibility (EMC).
- 5.2.13. Safety against false alarm in the event of an impact on the vehicle
- It shall be verified that an impact of up to 4,5 Joules of a hemispherical body with 165 mm in diameter and  $(70 \pm 10)$  Shore A applied anywhere to the vehicle bodywork or glazing with this curved surface does not cause false alarms.
- 5.2.14. Safety against false alarm in the event of a voltage reduction
- It shall be verified that slow reduction of the main battery voltage by continuous discharge of 0,5 V/h down to 3 V does not cause false alarms.
- Test conditions: see item 5.2.1.2.
- 5.2.15. Test for safety against false alarm of the passenger compartment control
- Systems intended for the protection of the passenger compartment according to item 4.1.1 shall be tested together with a vehicle under normal conditions (item 5.2.1.2).
- The system, installed according to the manufacturer's instructions, shall not be triggered when subjected 5 times to the test described in item 5.2.13 at intervals of 0,5 s.
- The presence of a person touching or moving around the outside of the vehicle (windows closed) shall not cause any false alarm.
6. **Instructions**
- Each VAS shall be accompanied by:
- 6.1. Instructions for installation:
- 6.1.1. The list of vehicles and vehicle models for which the device is intended. This list may be specific or generic, e. g. 'all cars with petrol engines and 12 V negative earth batteries'.
- 6.1.2. The method of installation illustrated by photographs and/or very clear drawings.
- 6.1.3. In the case of VAS which include immobilizer, additional instructions regarding compliance with requirements of Annex V are to be provided.
- 6.2. A blank installation certificate, an example of which is given in Appendix 1 to this Annex.
- 6.3. A general statement to the VAS purchaser calling his attention to the following points:
- the VAS should be installed in accordance with the manufacturer's instructions,
  - the selection of a good installer is recommended (the VAS manufacturer may be contacted to indicate appropriate installers),
  - the installation certificate supplied with the VAS should be completed by the installer.
- 6.4. Instructions for use
- 6.5. Instructions for maintenance
- 6.6. A general warning regarding the danger of making any alterations or additions to the system; such alterations or additions would automatically invalidate the certificate of installation referred to in item 6.2.



**▼ M1**

- 6.7. Indication of the location(s) of the approval mark mentioned in Annex I of this Directive and/or the certificate of conformity mentioned in this Directive.

## PART II

## APPROVAL OF A VEHICLE WITH REGARD TO ITS ALARM SYSTEM

When a VAS approved to Part I of this Annex is being used in a vehicle submitted for approval to Part II of this Annex, tests required to be passed by a VAS in order to obtain approval to Part I of this Annex shall not be repeated.

7. **Definitions**

For the purpose of Part II of this Annex:

- 7.1. 'Alarm system(s)' (AS) means an arrangement of components fitted as original equipment in a vehicle type, designed to indicate intrusion into or interference with the vehicle; these systems may provide additional protection against unauthorized use of the vehicle.
- 7.2. 'Vehicle type with regard to its alarm system' means vehicles which do not differ significantly in such essential aspects as:
- the manufacturer's trade name or mark,
  - vehicle features which significantly influence the performances of the AS,
  - the type and design of the AS or VAS.
- 7.3. Other definitions applicable to Part II are contained in item 2 of this Annex.

8. **General specifications**

- 8.1. As shall be designed and built in such a way that they, in the event of intrusion into or interference with a vehicle, provide an alarm signal.
- The alarm signal shall be audible and in addition may include optical alarm devices, or be a radio alarm, or any combination of the above.
- 8.2. Vehicles which are equipped with alarm systems shall comply with the relevant technical requirements, especially with regard to electromagnetic compatibility (EMC).
- 8.3. If the AS includes the possibility of a radio transmission, e. g. for setting or unsetting of the alarm or for alarm transmission, it shall comply with the relevant ETSI standards (see footnote 3 pertinent to item 3.3). The frequency must be 433,92 MHz and the maximum radiated power 25 mW.
- 8.4. The AS and components thereof shall not activate inadvertently, particularly whilst the engine is in its running mode.
- 8.5. Failure of the AS, or failure of its electrical supply, shall not affect the safe operation of the vehicle.
- 8.6. The alarm system, its components and the parts controlled by them shall be so installed as to minimize the risk for anyone to make them inoperative or to destroy them rapidly and without calling attention, e. g. using low-cost, easily-concealed tools, equipment or fabrications readily available to the public at large.

**▼ M1**

8.7. The system shall be so arranged that the shorting out of any alarm signal circuit shall not render inoperative any aspects of the alarm system, other than the circuit which is shorted out.

8.8. The AS may include an immobilizer which shall comply with the requirements of Annex V.

9. **Particular specifications**

9.1. Protection range

9.1.1. Specific requirements

The AS shall at least detect and signal the opening of any vehicle door, engine bonnet and luggage compartment. The failure or switching off of light sources, e. g. passenger compartment light, shall not impair the control operation..

The installation of additional efficient sensors for information/display, e. g.:

— of intrusions into the vehicle, e. g. passenger compartment control, window glass control, breakage of a glazed area, or

— of attempted vehicle theft, e. g. inclination sensor,

are allowed, taking account of measures to prevent any unnecessary sounding of the alarm (false alarm, see item 9.1.2).

In so far as these additional sensors generate an alarm signal even after an intrusion has occurred (e. g. by breakage of a glazed area) or under external influences (e.g. wind), the alarm signal, activated by one of the abovementioned sensors, shall be activated not more than 10 times within the same activation period of the AS.

In this case the activation period shall be limited by the unsetting of the system as a result of the vehicle user's action.

Some kinds of additional sensors, e. g. passenger compartment control (ultrasonic, infra-red) or inclination sensor, etc., may be intentionally deactivated. In this case, separate deliberate action must be taken each time before the AS is set. It must not be possible to deactivate the sensors while the alarm system is in a set state.

9.1.2. Safety against false alarm

9.1.2.1. It shall be ensured that the AS both in set and unset conditions, cannot cause the alarm signal to sound unnecessarily, in the event of:

— an impact on the vehicle: test specified in item 5.2.13,

— reduction of battery voltage by continuous discharge; test specified in item 5.2.14,

— false alarm of the passenger compartment control: test specified in item 5.2.15.

9.1.2.2. If the applicant for approval can demonstrate, e. g. by technical data, that safety against false alarm is satisfactorily ensured, the technical service responsible for conduction approval tests may not require some of the above tests.

9.2. Audible alarm

9.2.1. General

The alarm signal shall be clearly audible and recognizable and shall differ significantly from the other audible signals used in road traffic.

**▼ M1**

In addition to the original equipment audible warning device, a separate audible alarm signal device may be fitted in the area of the vehicle which is controlled by the AS, where it shall be protected against easy, rapid access by persons.

If a separate audible alarm signal device according to item 9.2.3.1 below is used, the original equipment standard audible warning device may additionally be actuated by the AS, provided that any tampering with the standard audible warning device (generally more easily accessible) does not affect the operation of the separate audible alarm signal device.

9.2.2. Duration of the audible alarm signal

Minimum: 25 s

Maximum: 30 s.

The audible alarm signal may sound again only after the next interference with the vehicle, i. e. after the abovementioned time span. (Restrictions: see item 9.1.1 and 9.1.2).

Unsetting of the alarm system shall immediately cut the alarm signal.

9.2.3. Specifications concerning the audible alarm signal.

9.2.3.1. Constant tone alarm signal device (constant frequency spectrum), e. g. horns: acoustical, etc. data according to Appendix 4 of this Annex.

Intermittent alarm signal (on/off):

Trigger frequency  $2 \text{ Hz} \pm 1 \text{ Hz}$

On time = off time  $\pm 10 \%$

9.2.3.2. Audible alarm signal device with frequency modulation:

acoustical, etc. data according to Appendix 4 of this Annex but equal passage of a significant frequency range with the abovementioned range (1 800 through 3 550 Hz) in both directions.

Passage frequency  $2 \text{ Hz} \pm 1 \text{ Hz}$

9.2.3.3. Sound level

The sound source shall be:

— either an audible warning device approved under Directive 70/388/EEC, Section 1 or a device meeting the requirements of items 1 and 2 of Appendix 4 to this Annex,

— however, in the case of a sound source different from the original equipment audible warning device, the minimum sound level may be reduced to 100 dB (A), measured under the conditions of Appendix 4 of this Annex.

9.3. Optical alarm — if fitted

9.3.1. General

In the event of intrusion into or interference with the vehicle the device shall activate an optical alarm as specified in items 9.3.2 and 9.3.3.

9.3.2. Duration of the optical alarm signal

The optical alarm signal shall have a duration between 25 s and 5 minutes after the alarm has been activated. The unsetting of the alarm system shall immediately stop the alarm signal.

**▼ M1**

- 9.3.3. Type of optical alarm signal
- Flashing of all direction indicators and/or passenger compartment light of the vehicle including all lamps in the same electrical circuit.
- Trigger frequency  $2 \text{ Hz} \pm 1 \text{ Hz}$
- In relation to the audible signal, also asynchronous signals are allowed.
- One time = off time  $\pm 10 \%$
- 9.4. Radio alarm (pager) — if fitted
- The AS may include a facility generating an alarm signal by radio transmission.
- 9.5. Alarm system setting lock
- 9.5.1. When the engine is in its running mode, deliberate or inadvertent setting of the alarm system shall be impossible.
- 9.6. Setting and unsetting of the alarm system
- 9.6.1. Setting
- Any suitable means of setting of the AS is allowed, provided that such means does not inadvertently cause false alarms.
- 9.6.2. Unsetting
- Unsetting of the AS shall be achieved by one or a combination of the following devices.
- Other devices giving equivalent performance are permitted.
- 9.6.2.1. A mechanical key (complying with requirements of Appendix 3 to this Annex) which can be coupled with a centralized vehicle locking system comprising at least 1 000 variants, operated from the outside.
- 9.6.2.2. Electrical/electronic device, e. g. remote control, with at least 50 000 variants which shall incorporate a rolling code and/or have a minimum scan time of 10 days, e. g. a maximum of 5 000 variants per 24 hours for 50 000 variants minimum.
- 9.6.2.3. A mechanical key or an electrical/electronic device within the protected passenger compartment, with time exit/entry delay.
- 9.7. Exit delay
- If the switching device for setting the AS is fitted within the protected area, an exit delay shall be provided. It shall be possible for the exit delay to be set between 15 seconds and 45 seconds after the switch has been operated. The delay period may be adjustable to suit individual operators circumstances.
- 9.8. Entry delay
- If the device for unsetting the AS is fitted within the protected area, a delay of 5 seconds minimum and 15 seconds maximum shall be allowed before the activation of the audible and optical alarm signals. The delay period may be adjustable to suit individual operators circumstances.
- 9.9. Status display
- 9.9.1. To provide information on the status of the AS (set, unset, alarm setting period alarm has been activated), the installation of optical displays is allowed inside and outside the passenger compartment. The light intensity of optical signals installed outside the passenger compartment shall not exceed 0,5 cd.

**▼ M1**

- 9.9.2. If an indication of short-term 'dynamic' processes such as changes from 'set' to 'unset' and vice versa is provided, it shall be optical, according to paragraph 9.9.1. Such optical indication may also be produced by the simultaneous operation of direction indicators and/or passenger compartment lamp(s), provided that the duration of the optical indication by direction indicators does not exceed 3 seconds.
- 9.10. Power supply
- The source of power for the AS may be the vehicle battery.
- Where provided, an additional battery shall be rechargeable and it shall by no means supply energy to the other parts of the vehicle's electrical system.
- 9.11. Specifications for optional functions
- 9.11.1. Self check, automatic failure indication
- On setting the AS, irregular situations, e. g. open doors, etc., may be detected by a self-check function (plausibility control), and this situation may be indicated.
- 9.11.2. Panic alarm
- An optical and/or audible and/or radio alarm is allowed independent of the state (set or unset) and/or function of the AS. Such an alarm shall be triggered from within the vehicle and shall not affect the state (set or unset) of the AS. Also it must be possible for the vehicle user to switch off the panic alarm. In the case of an audible alarm, its sounding duration per activation shall not be restricted. A panic alarm shall not immobilize the engine or stop it if it is running.
10. **Test conditions**
- All components of the VAS or AS shall be tested in accordance with procedures described in item 5.
- This requirement does not apply to:
- 10.1. Those components that are fitted and tested as part of the vehicle, whether or not a VAS/AS is fitted (e. g. lamps); or
- 10.2. Those components that have previously been tested as part of the vehicle and documentary evidence has been provided.
11. **Instructions**
- Each vehicle shall be accompanied by:
- 11.1. Instructions for use
- 11.2. Instructions for maintenance
- 11.3. A general warning regarding the danger of making any alterations or additions to the system.

▼ **M1**

*Appendix 1*

*Appendix 1*

**Model of installation certificate**

I the undersigned, . . . , professional installer, certify that the installation of the vehicle alarm system described below has been carried out by myself pursuant to the mounting instructions supplied by the manufacturer of the system.

Description of the vehicle:

Make:

Type:

Serial number:

Registration number:

Description of the vehicle alarm system

Make:

Type:

Approval number:

Done at: ..... on: .....

Installer's full address (and stamp, if appropriate):

Signature: .....  
(please specify job position)

▼ M1

*Appendix 2*

Item 5.2.11

**Test of systems for the protection of the passenger compartment**

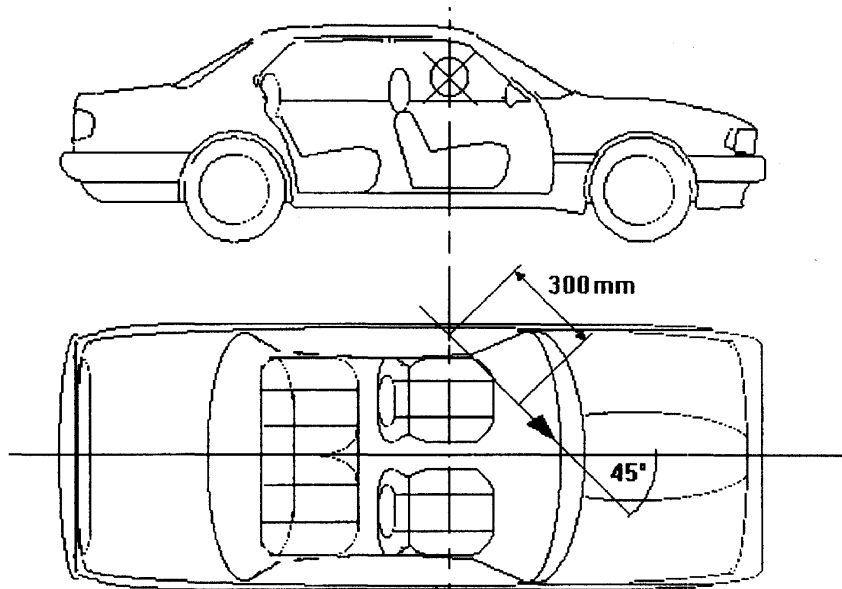

**▼ M1***Appendix 3***Specification for mechanical key switches**

1. The cylinder of the key switch shall not protrude by more than 1 mm from the cowling, and the protruding part shall be conical.
2. The joint between the cylinder core and the cylinder casing shall be capable of withstanding a tensile force of 600 N and a torque of 25 Nm.
3. The key switch shall be provided with a cylinder drill obstruction.
4. The key profile shall have at least 1 000 effective permutations.
5. The key switch shall not be operable by a key which differs by only one permutation from the key matching the key switch.
6. The key aperture to an external key switch shall be shuttered or otherwise protected against the penetration of dirt and/or water.



▼ **M1***Appendix 4***Technical prescriptions for audible alarm devices (AAD)**

1. The AAD shall emit a continuous and uniform sound, its acoustic spectrum shall not vary substantially during its operation. For AAD supplied with alternating current, this requirement shall apply only at constant generator speed, within the range specified in item 2.1.3.2.
2. The AAD shall have acoustic characteristics (spectral distribution of the acoustic energy sound pressure level) and mechanical characteristics such than it can satisfy the following tests, in the order indicated.

## 2.1. Measurement of sound characteristics

- 2.1.1. The AAD should, preferably, be tested in an anechoic environment. Alternatively, it may be tested in a semi-anechoic chamber or in an open space. In this case, precautions shall be taken to avoid reflections from the ground within the measuring area (for instance by erecting a set of absorbing screens). Compliance with the spherical divergence to a limit of 1 dB within a hemisphere of not less than 5 m radius, up to the maximum frequency to be measured, especially in the measuring direction and at the height of the apparatus and the microphone, shall be checked.

The ambient noise level shall be at least 10 dB lower than the sound pressure level to be measured.

The device to be tested and the microphone shall be placed at the same height. This height shall be between 1,15 and 1,25 m. The axis of maximum sensitivity of the microphone shall coincide with the direction of the maximum sound level of the device.

The microphone shall be so placed that its diaphragm is at a distance of  $2 \pm 0,01$  m from the plane of the sound outlet of the device. In the case of devices with several outlets, the distance shall be determined in relation to the plane of the nearest outlet to the microphone.

- 2.1.2. The measurements of the sound pressure levels shall be made with a class 1 precision sound level meter conforming to the specifications of IEC Publication No 651, first edition (1979).

All measurements shall be made using the time constant 'F'. The measurement of the overall sound pressure level shall be made using the weighting curve A.

The spectrum of the sound emitted shall be measured according to the Fourier transform of the acoustic signal. Alternatively one-third octave filters conforming to the specifications of IEC Publication No 225, first edition (1966) may be used:

in this case, the sound pressure level in the mid-band frequency 2 500 Hz shall be determined by adding the quadratic means of the sound pressures in the one-third mid-band frequencies 2 000, 2 500 and 3 150 Hz.

In every case, only the Fourier transform method shall be regarded as a reference method.

- 2.1.3. The AAD shall be supplied with current, as appropriate, at the following voltages:
  - 2.1.3.1. in the case of AAD supplied with direct current, at one of the test voltages of 6,5, 13 or 26 volts measured at the terminal of the electric power source and corresponding respectively to rated voltages of 6, 12 or 24 volts;

**▼ M1**

- 2.1.3.2. in the case of AAD supplied with alternating current, the current shall be supplied by an electric generator of the type normally used with this type of AAD. The acoustic characteristics of the AAD shall be recorded for electric generator speeds corresponding to 50 %, 75 % and 100 % of the maximum speed indicated by the manufacturer of the generator for continuous operation. During this test, no other electrical load shall be imposed on the electric generator. The endurance test described in item 3 shall be carried out at a speed indicated by the manufacturer of the equipment and selected from the above range.
- 2.1.4. If a rectified current source is used for the tests of an AAD supplied with direct current, the alternating component of the voltage measured at its terminals, when the warning devices are in operation, shall not be more than 0,1 volt, peak to peak.
- 2.1.5. For AAD supplied with direct current, the resistance of the connecting leads, including terminals and contacts, shall be as close as possible to:
- 0,05 ohms for a 6 volt circuit,
  - 0,10 ohms for a 12 volt circuit,
  - 0,20 ohms for a 24 volt circuit.
- 2.1.6. The device shall be rigidly mounted, using the part or parts provided by the manufacturer, on a support whose mass is at least 10 times that of the device and not less than 30 kg. In addition, arrangements must be made to ensure that reflexions on the sides of the support and its own vibrations have not appreciable affect on the measuring results.
- 2.1.7. Under the conditions set forth above, the sound-pressure level weighted in accordance with curve A shall not exceed 118 dB(A).
- 2.1.7.1. In addition, the sound pressure level in the frequency band 1 800 to 3 500 Hz shall be greater than that of any component of a frequency above 3 500 Hz and in any event equal to or greater than 105 dB (A).
- 2.1.8. The specifications indicated above shall also be met by a device subjected to the endurance test referred to in item 3 below, with the supply voltage varying between 115 % and 95 % of its rated voltage for AAD supplied with direct current or, for AAD supplied with alternating current, between 50 % and 100 % of the maximum speed of the generator indicated by the manufacturer for continuous operation.
- 2.1.9. The time lapse between the moment of activation and the moment at which the sound reaches the minimum level laid down in item 2.1.7 shall not exceed 0,2 seconds, measured in an ambient temperature of  $20 \pm 5$  °C.
- This provision shall apply in particular to pneumatically or electro-pneumatically operated devices.
- 2.1.10. Devices which are pneumatically or electro-pneumatically operated shall, with the pneumatic circuit arranged in accordance with the manufacturer's specification, have the same acoustic performance as that required for electrically operated audible AAD.
- 2.1.11. In the case of multiple-tone devices in which each sound-emitting unit is capable of functioning independently, the minimum values specified above shall be obtained when each of the constituent units is operated separately. The maximum value of the overall sound level shall not be exceeded when all the constituent units are operated simultaneously.

**▼ M1**

3. Endurance tests
  - 3.1. The AAD shall be supplied with current at the rated voltage and with the connecting lead resistances specified in items 2.1.3 and 2.1.5, and operated 50 000 times, each time for one second followed by an interval of four seconds. During the test, the AAD shall be ventilated by an air current having a speed of approximately 10 m/sec.
  - 3.2. If the test is carried out in an anechoic chamber, the latter shall be of sufficient volume to allow normal dispersal of the heat emitted by the device during the endurance test.
  - 3.3. The ambient temperatures in the test room shall be between + 15 and + 30 °C.
  - 3.4. If, after the AAD has been operated for half the number of times prescribed, the sound-level characteristics are no longer the same as before the test, the AAD may be adjusted. After being operated the prescribed number of times, and after further adjustment if necessary, the AAD must pass the test described in item 2.1.
  - 3.5. For warning devices of the electro-pneumatic type, the device may be lubricated with the oil recommended by the manufacturer after every 10 000 times of the operation.
4. Approval tests
  - 4.1. The tests shall be carried out on two samples of each type submitted by the manufacturer for approval; both the samples shall be subjected to all the tests and must conform to the technical specifications laid down in this Appendix.