

## COUNCIL DIRECTIVE

of 27 July 1976

on the approximation of the laws of the Member States relating to motor-vehicle headlamps which function as main-beam and/or dipped-beam headlamps and to incandescent electric filament lamps for such headlamps

(76/761/EEC)

THE COUNCIL OF THE EUROPEAN COMMUNITIES,

Having regard to the Treaty establishing the European Economic Community, and in particular Article 100 thereof,

Having regard to the proposal from the Commission,

Having regard to the opinion of the European Parliament <sup>(1)</sup>,

Having regard to the opinion of the Economic and Social Committee <sup>(2)</sup>,

Whereas the technical requirements which motor vehicles must satisfy pursuant to national laws relate *inter alia* to headlamps which function as main-beam and/or dipped-beam headlamps and their filament lamps;

Whereas these requirements differ from one Member State to another; whereas it is therefore necessary that all Member States adopt the same requirements either in addition to or in place of their existing rules, in order, in particular, to allow the EEC type-approval procedure which was the subject of Council Directive 70/156/EEC of 6 February 1970 on the approximation of the laws of the Member States relating to the type-approval of motor vehicles and their trailers <sup>(3)</sup>, to be introduced in respect of each type of vehicle;

Whereas in Directive 76/756/EEC <sup>(4)</sup>, the Council laid down the common requirements for the installation of lighting and light-signalling devices on motor vehicles and their trailers;

Whereas a harmonized type-approval procedure for headlamps which function as main-beam and/or dipped-beam headlamps and their filament lamps makes it possible for each Member State to check compliance with the common construction and testing

requirements and to inform the other Member States of its findings by sending a copy of the component type-approval certificate completed for each type of such headlamp or filament lamp; whereas the placing of an EEC component type-approval mark on all headlamp devices manufactured in conformity with the approved type obviates any need for technical checks on these headlamp devices in the other Member States;

Whereas it is desirable to take into account the technical requirements adopted by the UN Economic Commission for Europe in its Regulations No 1 ('Uniform provisions for the approval of motor vehicle headlights emitting an asymmetrical passing beam or a driving beam or both') <sup>(5)</sup> and No 2 ('Uniform provisions concerning approval of incandescent electrical lamps for headlights emitting an asymmetrical passing beam or a driving beam or both') <sup>(5)</sup>, which are annexed to the Agreement of 20 March 1958 concerning the adoption of uniform conditions for approval and reciprocal recognition of approval for motor vehicles equipment and parts;

Whereas the approximation of national laws relating to motor vehicles entails reciprocal recognition by Member States of the checks carried out by each of them on the basis of the common requirements,

HAS ADOPTED THIS DIRECTIVE:

*Article 1*

1. Each Member State shall grant EEC component type-approval for any type of headlamp which functions as a main-beam and/or dipped-beam headlamp and satisfies the construction and testing requirements laid down in Annexes I and VI, and any type of incandescent electric filament lamp for such headlamps which satisfies the construction and testing requirements laid down in Annexes III and VI.

<sup>(1)</sup> OJ No C 76, 7. 4. 1975, p. 37.

<sup>(2)</sup> OJ No C 255, 7. 11. 1975, p. 2.

<sup>(3)</sup> OJ No L 42, 23. 2. 1970, p. 1.

<sup>(4)</sup> See page 1 of this Official Journal.

<sup>(5)</sup> Economic Commission for Europe, Document  
E/ECE/324 } Addendum 1 of 24 March 1960.  
E/ECE/TRANS/505 }

2. The Member State which has granted EEC component type-approval shall take the measures required in order to verify that production models conform to the approved type, in so far as this is necessary and if need be in cooperation with the competent authorities in the other Member States. Such verification shall be limited to spot checks.

#### *Article 2*

Member States shall, for each type headlamp which functions as a main-beam and/or dipped-beam headlamp or filament lamp for such headlamp which they approve pursuant to Article 1, issue to the manufacturer, or to his authorized representative, an EEC component type-approval mark conforming to the model shown in Annex VI.

Member States shall take all appropriate measures to prevent the use of marks liable to create confusion between headlamps which function as main-beam and/or dipped-beam headlamps and filament lamps for such headlamps which have been type-approved pursuant to Article 1, and other devices.

#### *Article 3*

1. No Member State may prohibit the placing on the market of headlamps which function as main-beam and/or dipped-beam headlamps and filament lamps for such headlamps on grounds relating to their construction or method of functioning, if they bear the EEC component type-approval mark.

2. Nevertheless, a Member State may prohibit the placing on the market of headlamps which function as main-beam and/or dipped-beam headlamps and filament lamps for such headlamps bearing the EEC component type-approval mark which consistently fail to conform to the approved type.

That State shall forthwith inform the other Member States and the Commission of the measures taken, specifying the reasons for its decision.

#### *Article 4*

The competent authorities of each Member State shall within one month send to the competent authorities of the other Member States a copy of the component type-approval certificates, examples of which are given in Annexes II and IV, completed for each type of headlamp which functions as a main-beam and/or dipped-beam headlamp and each type of filament lamp for such headlamps which they approve or refuse to approve.

#### *Article 5*

1. If the Member State which has granted EEC component type-approval finds that a number of headlamps which function as main-beam and/or dipped-beam headlamps or filament lamps for such headlamps bearing the same EEC component type-

approval mark do not conform to the type which it has approved, it shall take the necessary measures to ensure that production models conform to the approved type. The competent authorities of that State shall advise those of the other Member States of the measures taken, which may, where there is consistent failure to conform, extend to withdrawal of EEC component type-approval. The said authorities shall take the same measures if they are informed by the competent authorities of another Member State of such failure to conform.

2. The competent authorities of Member States shall within one month inform each other of any withdrawal of EEC component type-approval, and of the reasons for such a measure.

#### *Article 6*

Any decision taken pursuant to the provisions adopted in implementation of this Directive to refuse or withdraw EEC component type-approval for a main-beam or a dipped-beam headlamp or for a filament lamp for such headlamps or prohibit their placing on the market or use shall set out in detail the reasons on which it is based. Such decision shall be notified to the party concerned, who shall at the same time be informed of the remedies available to him under the laws in force in the Member States and of the time limits allowed for the exercise of such remedies.

#### *Article 7*

No Member State may refuse to grant EEC type-approval or national type-approval of a vehicle on grounds relating to its headlamps which function as main-beam and/or dipped-beam headlamps or to the filament lamps for such headlamps if these bear the EEC component type-approval mark and are fitted in accordance with the requirements laid down in Directive 76/756/EEC.

#### *Article 8*

No Member State may refuse or prohibit the sale or registration, entry into service or use of a vehicle on grounds relating to its headlamps which function as main-beam and/or dipped-beam headlamps or to the filament lamps for such headlamps if these bear the EEC component type-approval mark and are fitted in accordance with the requirements laid down in Directive 76/756/EEC.

#### *Article 9*

For the purposes of this Directive, 'vehicle' means any motor vehicle intended for use on the road, with or without bodywork, having at least four

wheels and a maximum design speed exceeding 25 km/h, with the exception of vehicles which run on rails, agricultural tractors and machinery and public works vehicles.

*Article 10*

Any amendments necessary to adjust the requirements of the Annexes to take account of technical progress shall be adopted in accordance with the procedure laid down in Article 13 of Directive 70/156/EEC.

*Article 11*

1. Member States shall adopt and publish the provisions necessary in order to comply with this Directive before 1 July 1977 and shall forthwith inform the Commission thereof. They shall apply these provisions from 1 October 1977 at the latest.

2. Once this Directive has been notified, the Member States shall also ensure that the Commission is informed, in sufficient time for it to submit its comments, of any draft laws, regulations or administrative provisions which they propose to adopt in the field covered by this Directive.

*Article 12*

This Directive is addressed to the Member States.

Done at Brussels, 27 July 1976.

*For the Council*

*The President*

M. van der STOEL

### List of Annexes

Annex I (*)	— Requirements relating to motor vehicle headlamps which function as main-beam and/or dipped-beam headlamps
Annex II	— Model EEC component type-approval certificate
Annex III (*)	— Requirements relating to incandescent electric filament lamps for headlamps which function as dipped-beam and/or main-beam headlamps
Annex IV	— Model EEC component type-approval certificate
Annex V (*)	— Appendices 1 to 4: Figures and tables
Annex VI	— EEC component type-approval and marking requirements — Appendix: Examples of EEC component type-approval marks

(\*) The technical requirements of this Annex are similar to those of Regulations No 1 and No 2 of the Economic Commission for Europe. In particular, the breakdown into sections is the same. For this reason, where a section in Regulations No 1 and No 2 has no counterpart in this Directive, its number is given in brackets for the record.

### ANNEX I

#### REQUIREMENTS RELATING TO MOTOR VEHICLE HEADLAMPS WHICH FUNCTION AS MAIN-BEAM AND/OR DIPPED-BEAM HEADLAMPS

##### (DEFINITION, GENERAL SPECIFICATIONS, ILLUMINATION, CONFORMITY OF PRODUCTION, STANDARD HEADLAMP)

1. DEFINITION
  - 1.1. Type of headlamp
 

'Type of headlamp' means headlamps which do not differ in such essential matters as:

    - 1.1.1. the trade name or mark;
    - 1.1.2. the characteristics of the optical system;
    - 1.1.3. the inclusion of additional components capable of altering the optical effects by reflection, refraction or absorption;
    - 1.1.4. suitability for right-hand or left-hand traffic or for both traffic systems;
    - 1.1.5. ability to provide a dipped beam or a main beam or both.
  - (2.)
  - (3.)
  - (4.)
5. GENERAL SPECIFICATIONS
  - 5.1. Each sample shall conform to the specifications set forth in sections 6 and 7.

- 5.2. Headlamps must be so designed and constructed that under normal conditions of use, notwithstanding any vibration to which they may be subjected during such use, their satisfactory operation remains assured and they retain the photometric characteristics prescribed by this Directive.
- 5.3. The components by which the filament lamp is fixed to the reflector shall be so made that, even in darkness, the filament lamp can be fixed in no position but the correct one <sup>(1)</sup>.
- 5.4. Headlamps designed to satisfy the requirements both of Member States in which traffic moves on the right and of those in which it moves on the left may be adapted for traffic on a given side of the road either by an appropriate initial adjustment when the vehicle is fitted out or by selective setting by the driver. Such initial adjustment or selective setting shall consist, for example, of fixing either the optical unit at a given angle on the vehicle or the filament lamp at a given angle in relation to the optical unit. In all cases only two precisely differentiated setting positions, one for right-hand and one for left-hand traffic, shall be possible, and the design shall preclude inadvertent shifting of the headlamp from one position to another or its setting in an intermediate position. Where two different setting positions are provided for the filament lamp, the components attaching the filament lamp to the reflector must be so designed and manufactured that the filament lamp is fixed in each of its two positions with the same accuracy as that required for lamps intended for traffic on only one side of the road.

Conformity with the requirements of this section shall be verified visually and, where necessary, by a trial fitting.

## 6. ILLUMINATION

- 6.1. Headlamps must be so made that the dipped-beam filaments of suitable lamps give adequate illumination without dazzle, while the main-beam filaments of suitable lamps also give good illumination.

The illumination produced by the headlamp shall be checked on a vertical screen set at a distance of 25 m in front of the headlamp and at right angles to its axis (see Appendices 1 and 2 to Annex V), and with a standard filament lamp designed for a nominal voltage of 12 V, having a smooth and colourless glass envelope and exhibiting the following characteristics at that voltage:

	Consumption (watts)	Light flux (lumens)
Dipped-beam filament	40 ± 5%	450 ± 10%
Main-beam filament	45 ± 0% — 10%	700 ± 10%

The dimensions determining the position of the filaments inside the standard filament lamp are shown in the figure in Appendix 3 to Annex V. The standard filament lamp shall be supplied with current at a voltage which gives the nominal light-flux values.

- 6.2. The dipped beam shall produce on the screen a 'cut-off' sufficiently sharp as to allow of satisfactory adjustment. The 'cut-off' shall be a horizontal straight line on the side opposite to the direction of the traffic for which the headlamp is intended; on the other side it should be horizontal or within an angle of 15° above the horizontal.

<sup>(1)</sup> It is considered that an arrangement satisfies the requirements of this section when the filament lamp can be easily fitted into the headlamp and the positioning lug can be correctly fitted into its slot even in darkness, the slot being of exactly the right size. It is considered that an arrangement whereby the filament lamp is perceptibly tilted when in the wrong position, but not when in the correct position, adequately satisfies the requirements of 5.3.

The headlamp shall be so adjusted that:

- in the case of headlamps designed to meet the requirements of right-hand traffic, the 'cut-off' on the left half of the screen <sup>(1)</sup> is horizontal and in the case of headlamps designed to meet the requirements of left-hand traffic, the 'cut-off' on the right half of the screen is horizontal,
- this horizontal part of the 'cut-off' is situated on the screen 25 cm below the outline of the horizontal plane passing through the focus of the headlamp (see Appendices 1 and 2 to Annex V),
- the screen is in the position indicated in Annex V, Appendices 1 and 2 <sup>(2)</sup>.

When so adjusted, the headlamp shall, if it is intended to provide a dipped beam and a main beam, comply with the requirements set out in 6.3 and 6.4. If it is intended primarily to provide a dipped beam, it need comply only with the requirements of 6.3 <sup>(3)</sup>.

Where a headlamp so adjusted does not meet the requirements referred to in 6.3 and 6.4, its adjustment may be changed, provided that the axis of the beam or the point of intersection H specified in Appendices 1 and 2 to Annex V is not laterally displaced by more than 1° (= 440 mm) to the right or left <sup>(4)</sup>. To facilitate adjustment by means of the 'cut-off', the headlamp may be partially occulted in order to sharpen the 'cut-off'.

If the headlamp is designed solely to provide a main beam, it shall be so adjusted that the area of maximum illumination is centred on the point of intersection of the lines hh and vv. Such a headlamp need meet only the requirements of 6.4.

- 6.3. The illumination produced on the screen by the dipped beam shall meet the following requirements:

Point on measuring screen		Required illumination in lux
Headlamps for right-hand traffic	Headlamps for left-hand traffic	
Point B 50 L	Point B 50 R	≤ 0.3
Point B 75 R	Point B 75 L	≥ 6.0
Point B 50 R	Point B 50 L	≥ 6.0
Point B 25 L	Point B 25 R	≥ 1.5
Point B 25 R	Point B 25 L	≥ 1.5
Any point in Zone III		≤ 0.7
Any point in Zone IV		≥ 2.0
Any point in Zone I		≤ 20.0

Where the flux of the standard filament lamp used for measurement is other than 450 lumens, the measurements as taken must be corrected in proportion to the values of the fluxes.

There shall be no lateral variation detrimental to good visibility in any of Zones I, II, III and IV.

<sup>(1)</sup> The screen shall be sufficiently wide to allow examination of the 'cut-off' over a range of at least 5° from the line vv (see Appendices 1 and 2 to Annex V).

<sup>(2)</sup> If, in the case of a headlamp designed to satisfy the requirements of this Directive with respect to the dipped beam only, the focal axis diverges appreciably from the general direction of the beam, lateral adjustment shall be effected in the manner which best satisfies the requirements for illumination at points 75 and 50.

<sup>(3)</sup> A 'dipped-beam' headlamp of this kind may incorporate a main beam for which no specifications are laid down.

<sup>(4)</sup> The limit of non-adjustment of 1° to the right or left is not incompatible with vertical non-adjustment. The latter is limited only by the requirements of 6.4.

Headlamps designed to meet the requirements of both right-hand and left-hand traffic shall, in each of the two setting positions of the optical unit or of the filament lamp, meet the requirements set forth above for the corresponding traffic system.

- 6.4. Measurements of the illumination produced on the screen by the main beam shall be taken with the same headlamp adjustment as for measurements under 6.3, or, in the case of a headlamp providing a main beam only, in accordance with the final paragraph of 6.2.

The illumination produced on the screen by the main beam must satisfy the following requirements:

the point of intersection H of the lines hh and vv shall be situated within the isolux corresponding to 90% of maximum illumination. This maximum value shall not be less than 32 lux;

starting from point H, horizontally to the right and left, illumination shall be not less than 16 lux up to a distance of 1 125 mm and not less than four lux up to a distance of 2 250 mm. Where the flux of the standard filament lamp used for measurements is other than 700 lumens, the measurements as taken shall be corrected in proportion to the values of the fluxes.

- 6.5. The screen illumination values mentioned in 6.3 and 6.4 shall be measured by means of a photo-electric cell, the photo-sensitive area of which shall be contained within a square of side 65 mm.

(7.)

## 8. CONFORMITY OF PRODUCTION

Every headlamp bearing an EEC component type-approval mark shall conform to the approved type and comply with the photometric conditions specified in section 6.

(9.)

## 10. STANDARD HEADLAMP <sup>(1)</sup>

- 10.1. A 'standard headlamp' means a headlamp which:

- satisfies the above requirements for EEC component type-approval,
- has an effective diameter of not less than 160 mm,
- provides with a standard filament lamp, at the various points and in the various areas referred to in 6.3., illumination equal to:
  - not more than 90% of the maximum limits,
  - not less than 120% of the minimum limits prescribed in the table in 6.3.

(11.)

(12.)

---

<sup>(1)</sup> See Annex III, section 10.

ANNEX II

MODEL EEC COMPONENT TYPE-APPROVAL CERTIFICATE

(Maximum format: A4 (210 x 297 mm))

Name of administration

Notification concerning the granting, refusal or withdrawal of EEC component type-approval of a type of headlamp which functions as a main-beam and/or dipped-beam headlamp

Component type-approval No .....

- 1. Headlamp submitted for type-approval as type: CR, CR, CR, C, C, C, R (\*)
2. Trade name or mark .....
3. Name and address of manufacturer .....
4. If applicable, name and address of manufacturer's authorized representative .....
5. Submitted for EEC component type-approval on .....
6. Technical service conducting EEC component type-approval tests .....
7. Date of report issued by that service .....
8. Number of report issued by that service .....
9. Date of granting/refusal/withdrawal of EEC component type-approval (\*) .....
10. Single EEC component type-approval granted on the basis of section 3.3 of Annex VI for a lighting and light-signalling device comprising several lamps, and in particular (\*): .....
11. Date of refusal/withdrawal of the single EEC component type-approval (\*): .....
12. Place .....
13. Date .....
14. Signature .....
15. The attached drawing No ..... shows a front view of the headlamp with the pattern of the lens moulding, and in cross-section
16. Remarks .....

(\*) Delete where inapplicable.



## ANNEX III

**REQUIREMENTS RELATING TO INCANDESCENT ELECTRIC FILAMENT LAMPS FOR  
HEADLAMPS WHICH FUNCTION AS DIPPED-BEAM AND/OR MAIN-BEAM  
HEADLAMPS**

(DEFINITION, GENERAL SPECIFICATIONS, NOMINAL VALUES, MANUFACTURE,  
WATTAGE AND LIGHT-FLUX VALUES, COLOUR, OPTICAL QUALITY CHECK, NOTE  
CONCERNING COLOUR, CONFORMITY OF PRODUCTION)

## 1. DEFINITION

1.1. **Type of filament lamp**

'Type of filament lamp' means filament lamps that do not differ in such essential respects as:

- 1.1.1. the trade name or mark;
- 1.1.2. the nominal voltage;
- 1.1.3. the nominal wattage;
- 1.1.4. the shape of one or more filaments;
- 1.1.5. the colour of the glass envelope;
- 1.1.6. the design of the glass envelope and its effect on the optical results.

(2.)

(3.)

(4.)

## 5. GENERAL SPECIFICATIONS

- 5.1. Each sample shall conform to the photometric specifications set out in section 8.
- 5.2. All measurements shall be carried out at the 'test voltage' <sup>(1)</sup> with the filament lamps lit under the conditions laid down in section 8.
- 5.3. Filament lamps must be so made that under normal conditions of use, their satisfactory operation is assured, and continues to be so. They shall, moreover, exhibit no fault in design or manufacture.

## 6. NOMINAL VALUES

The nominal voltage values are: 6, 12 and 24 volts.

The nominal wattage values are:

Main-beam filament	Dipped-beam filament	
45 watts	40 watts	for 6 and 12 volts
55 watts	50 watts	for 24 volts

<sup>(1)</sup> These test voltages are fixed as follows:  
nominal voltage 6V, test voltage 6.0 V,  
nominal voltage 12 V, test voltage 12.0 V,  
nominal voltage 24 V, test voltage 24.0 V.

## 7. MANUFACTURE

7.1. The glass envelope of filament lamps shall have no scratches or spots which might impair their efficiency. No ray from the dipped-beam filament reflected by the sides of the glass envelope shall strike the axis of the filament lamp less than 6 mm (from the cap end) behind the first turn of that filament.

7.2. Filament lamp caps shall conform to the standard type shown in the figure in Appendix 4 to Annex V.

7.3. The position, shape and dimensions of the filaments and the ring inside the filament lamp shall conform to the specifications shown in the figure in Appendix 3 to Annex V.

7.4. The cap shall be strong and firmly secured to the glass envelope.

To ascertain whether filament lamps conform to the requirements of this section, a visual inspection, a dimension check and where necessary, a trial fitting, shall be carried out. The dimensions referred to in 7.3. shall be checked on filament lamps supplied with current at their test voltage, and, where necessary, by means of a projection system.

## 8. WATTAGE AND LIGHT-FLUX VALUES

The wattage of each filament shall not exceed the nominal wattage by more than 10 %. Light-flux values shall remain within the following limits:

Test voltage	Nominal wattage		Light flux in lumens			
	Filament		Dipped-beam filament		Main-beam filament	
	dipped beam	main beam	minimum	maximum	minimum	maximum
6.0						Unspecified
12.0	40	45	400	550	600	
24.0	50	55				

The check shall be made with the filament lamp in its normal position of use and supplied with current at its test voltage after having been lit for one hour under these conditions.

## 9. COLOUR

The filament lamp glass envelopes shall be colourless or of selective-yellow colour. In the latter case, the dominant wave-length of the light emitted shall be between 575 and 585 nm (nanometres); the purity factor shall be between 0.90 and 0.98, and the transmission factor shall be not less than 0.78 <sup>(1)</sup>, the values being determined for light emitted by an electric lamp filament at a colour temperature of 2 800 K and on a fragment of a filament lamp glass envelope which has been used in a headlamp at its test voltage for 48 hours.

<sup>(1)</sup> These specifications correspond to the following trichromatic coordinates:

SELECTIVE-YELLOW COLOUR: limit towards red:  $y \geq 0.138 + 0.580x$   
 limit towards green:  $y \leq 1.29x - 0.100$   
 limit towards white:  $y \geq -x + 0.966$   
 limit towards spectral value  $y \leq -x + 0.992$

10. OPTICAL QUALITY CHECK

The sample which most nearly meets the requirements laid down for the standard filament lamp shall be tested in a standard headlamp <sup>(1)</sup> to ensure that the assembly comprising this headlamp and the filament lamp being tested meet the component type-approval requirements for headlamps.

11. NOTE CONCERNING COLOUR

EEC component type-approval shall be granted if the colour of the light emitted is that laid down in 3.13 of Annex I to Directive 76/756/EEC.

12. CONFORMITY OF PRODUCTION

Every filament lamp bearing an EEC component type-approval mark shall conform to the approved type and comply with the photometric conditions specified above.

(13.)

(14.)

---

<sup>(1)</sup> See Annex I, section 10.

ANNEX IV

MODEL EEC COMPONENT TYPE-APPROVAL CERTIFICATE

(Maximum format: A4 (210 x 297 mm))

Name of administration

Notification concerning the granting, refusal or withdrawal of EEC component type-approval, or the granting, refusal or withdrawal of an extension of EEC component type-approval, in respect of a type of incandescent-electric filament lamp

Component type-approval No .....

- 1. Filament lamp with colourless/selective-yellow glass envelope (\*):
- nominal voltage .....
- nominal wattage(s) .....
2. Trade name or mark .....
3. Name and address of manufacturer .....
4. If applicable, name and address of manufacturer's authorized representative .....
5. Submitted for EEC component type-approval on .....
6. Technical service conducting the EEC component type-approval tests .....
7. Date of report issued by that service .....
8. Number of report issued by that service .....
9. Date of granting/refusal/withdrawal of EEC component type-approval (\*) .....
10. Extension of EEC component type-approval .....
11. Date of refusal/withdrawal of extension of EEC component type-approval (\*) .....
12. Place .....
13. Date .....
14. Signature .....
15. The attached drawing No ..... shows the entire filament lamp
16. Remarks .....

(\* ) Delete where inapplicable.

Appendix 1

ANNEX V  
Appendix 1

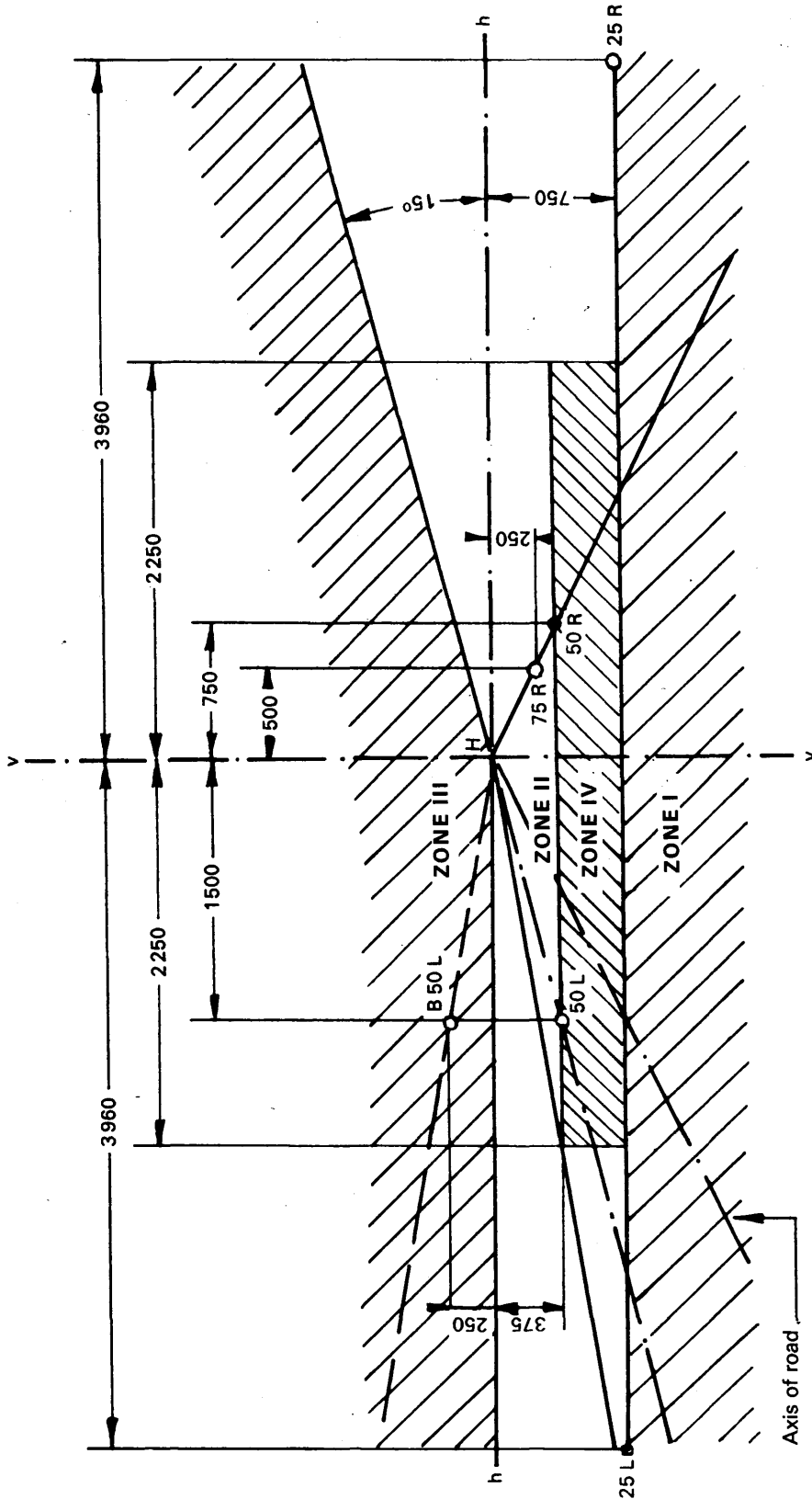

MEASURING SCREEN  
HEADLAMP FOR RIGHT-HAND TRAFFIC

h-h: horizontal plane }  
v-v: vertical plane } passing through the focal point of headlamp  
Dimensions in mm

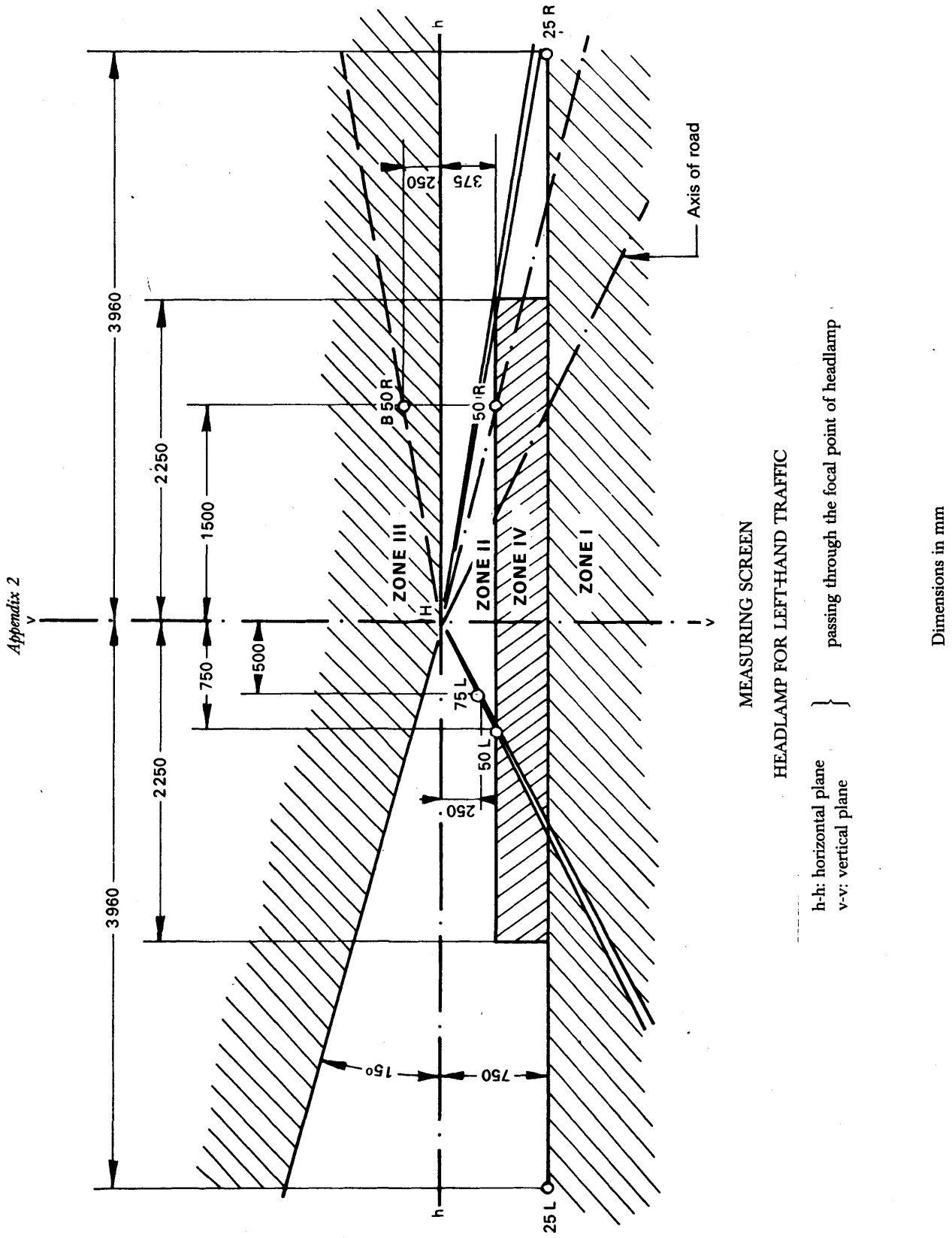

## Appendix 3

## DOUBLE-FILAMENT: INTERNAL ELEMENTS

1. Figure

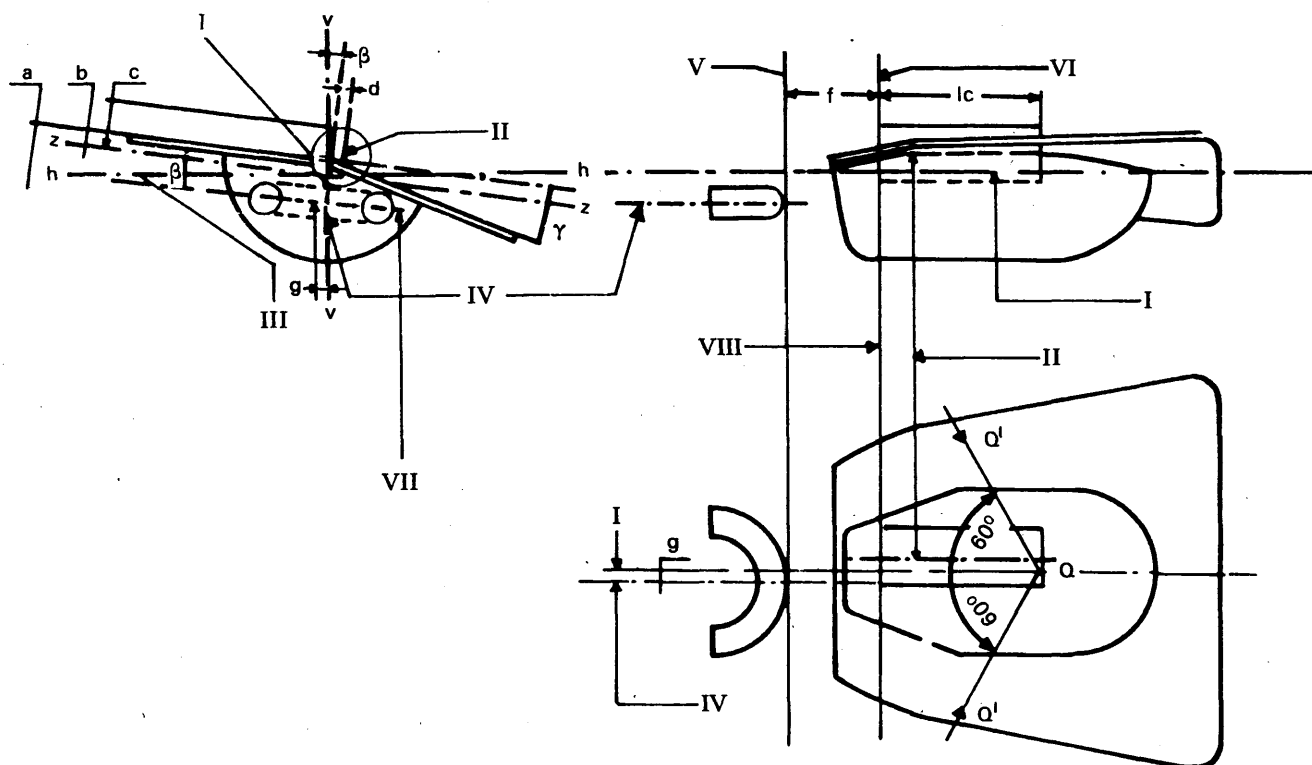

## Key

- I. Filament lamp axis.
- II. Axis of dipped-beam filament.
- III. Plane passing through the axis of the filament lamp perpendicular to the median plane of the positioning lug of reference plane 1.
- IV. Axis of main-beam filament.
- V. Last turn of main-beam filament.
- VI. First bright turn of dipped-beam filament.
- VII. The plane passing through the axis of the main-beam filament need not be parallel either with the plane h - h or with the plane z - z.
- VIII. Distance e from reference plane.

2. Table

Reference points	Nominal values (mm or degrees)	Tolerances (mm or degrees)	
		Standard filament lamp	Production sample
a	0.6	± 0.15	± 0.35
b	0.2	± 0.15	± 0.35
c	0.5	± 0.15	± 0.30
d	0	± 0.3	± 0.5
e	28.5 <sup>(1)</sup>	± 0.15	± 0.35
f	1.8 <sup>(2)</sup>	± 0.2	± 0.4
g	0	± 0.3	± 0.5
l <sub>c</sub>	5.5	± 0.5	± 1.5
β	0°	± 0° 30'	± 1° 30'
γ	15°	± 0° 30'	± 1° 30'
Q-Q'	3/4(l <sub>c</sub> +f)		

<sup>(1)</sup> 28.8 for 24-volt filament lamps.

<sup>(2)</sup> 2.2 for 24-volt filament lamps.

## 3. Notes

1. The axis of the filament lamp is the perpendicular to reference plane 1 (see figure in Appendix 4) drawn through the intersection of this plane with the axis of the corresponding centering cylinder.
2. The drawing is not mandatory with respect to the design of the shield and filaments.
3. The value established for Q - Q' applies solely to the standard filament used for the approval testing of a headlamp; the dimensions of the shield must be such that the points Q' are situated within the edge of the shield.
4. The tolerances indicated relate to the test required for the approval of a filament lamp type.



Appendix 4

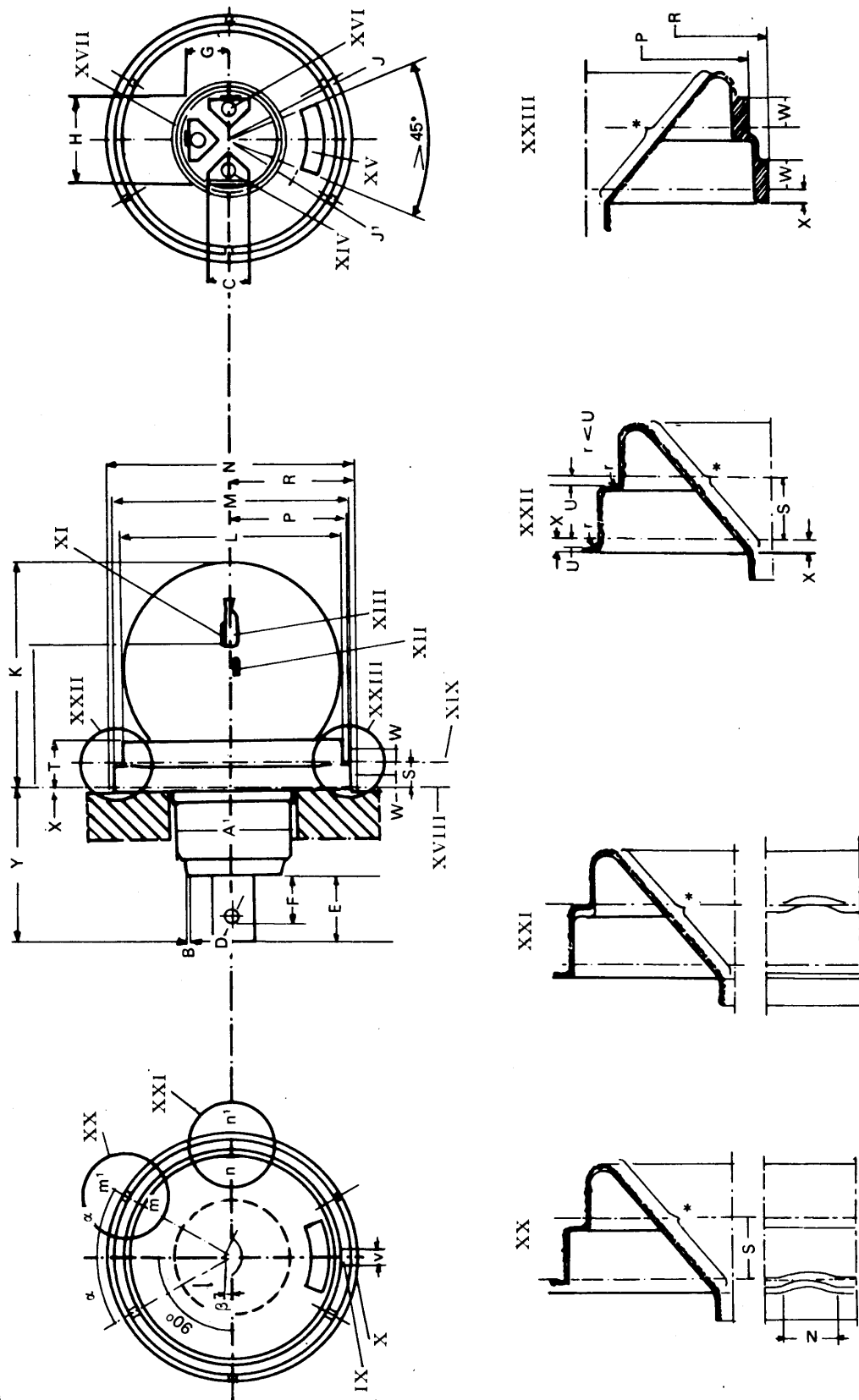

1. Figure

DOUBLE FILAMENT: INTERCHANGEABILITY

- Key
- IX. Positioning lug for reference plane 2.
  - X. Positioning lug for reference plane 1.
  - XI. Dipped-beam filament.
  - XII. Main-beam filament.
  - XIII. Shield.
  - XIV. Earthing contact strip.
  - XV. Window.
  - XVI. Main-beam contact strip.
  - XVII. Dipped-beam contact strip.
  - XVIII. Reference plane 1.
  - XIX. Reference plane 2.
  - XX. Section m-m.
  - XXI. Section n-n.
  - XXII, XXIII. Details.

2. Table

Reference points	Nominal values (mm or degrees)	Tolerances (mm or degrees)		Reference points	Nominal values (mm or degrees)	Tolerances (mm or degrees)	
		Standard filament lamp	Production sample			Standard filament lamp	Production sample
A <sub>1</sub> (*)	25 min.	—	—	N	47.2	± 0.2	± 0.2
B	0.7	+ 0.1 — 0.0	+ 0.1 — 0.0	P	21.5	+ 0.9 — 0.0	+ 0.9 — 0.0
C	7.7	+ 0.4 — 0.0	+ 0.4 — 0.0	R	23.7	+ 0.0 — 0.4	+ 0.0 — 0.4
D	3	+ 0.3 — 0.0	+ 0.3 — 0.0	S	4.7	± 0.06	± 0.20
E	11.8 to 13.6 <sup>(2)</sup>	—	—	T	9.5 max.	—	—
F	8.8 to 10.3	—	—	U	0.3 min.	—	—
G	8.5	+ 0.5 — 0.0	+ 0.5 — 0.0	V	3	± 0.05	± 0.10
H	17	+ 0.9 — 0.0	+ 0.9 — 0.0	W	2.2	+ 0.0 — 0.4	+ 0.0 — 0.4
J	18 min.	—	—	X	3 max.	—	—
J <sub>1</sub>	14.5 max.	—	—	Y	32 max.	—	—
K	50 max.	—	—	r	< U	—	—
L	41.5	+ 0.0 — 0.1	+ 0.0 — 0.2	α	—	25 to 35°	25 to 35°
M	45	+ 0.0 — 0.1	+ 0.0 — 0.2	β	0°	± 0°30'	± 1°30'
				e	28.5 <sup>(8)</sup>	± 0.15	± 0.35

(<sup>1</sup>) The symbols A<sub>1</sub> to α are, with the exception of K and Y, identical to the corresponding reference point symbol of the IEC standards.

(<sup>2</sup>) With soldering, IEC standard 7004-95-1.

(<sup>8</sup>) 28.8 mm for 24-volt filament lamps.

## 3. Notes

1. The foregoing reference points correspond to the standards (IEC Publications, sheets 7004-95-1, 7004-95A-1 and 7004-95B-1) adopted by the International Electrotechnical Commission.
2. Only the overall dimensions and the dimensions affecting interchangeability are shown in the drawing and are mandatory.
3. The internal structure of the filament lamp and the corresponding dimensions are given in the drawing in the figure in Appendix 3.
4. The part marked (\*) of the cap must not, by reflection of light emitted by the dipped-beam filament, throw any stray rising ray when the filament lamp is in the normal operating position on the vehicle.
5. The diameter of each centering cylinder is measured through any plane of straight section not less than 0.5 mm from the corresponding reference plane for the cylinder.
6. The relative eccentricity (distance between the axes) of the two centering cylinders must not exceed 0.05 mm.
7. A tolerance is allowed for the distance S — the distance between the two reference planes (4.7 mm) — which includes the admissible error in the parallelism of those two planes.
8. The two positioning lugs (IX and X) must be able to fit simultaneously into an opening not exceeding 3.1 mm.
9. The contact strips (XIV, XVI and XVII) must be placed in relation to the positioning lugs either in the position indicated in the drawing or at an angle of 180° from that position, with a tolerance of ± 20° in either case. The window (XV) and the dipped-beam contact strip (XVII) must face each other on opposite sides of the filament lamp axis.

## ANNEX VI

## EEC COMPONENT TYPE-APPROVAL AND MARKING REQUIREMENTS

1. APPLICATION FOR EEC COMPONENT TYPE-APPROVAL
  - 1.1. The application for EEC component type-approval shall be submitted by the holder of the trade name or mark or by his authorized representative.
  - 1.2. The application shall be accompanied by:
    - 1.2.1. for each type of headlamp which functions as a main-beam and/or dipped-beam headlamp:
      - 1.2.1.1. an indication as to whether the lamp is intended to provide both a dipped beam and main beam or only one of these beams; if the headlamp is intended to provide a dipped beam, whether it is designed for both left-hand and right-hand traffic or for either left-hand or right-hand traffic only;
      - 1.2.1.2. a brief technical specification;
      - 1.2.1.3. drawings (three copies), in sufficient detail to permit identification of the type and showing a front view of the headlamp with, if necessary, details of the pattern of the lens moulding, and in cross-section.

The drawings must indicate the position which the component type-approval mark, (particularly the type-approval number and the category reference[s]) is to occupy in the type-approval mark rectangle;
      - 1.2.1.4. two samples;
    - 1.2.2. for each type of filament lamp:
      - 1.2.2.1. a brief technical specification;
      - 1.2.2.2. drawings, (three copies), in sufficient detail to permit identification of the type and showing the entire filament lamp on the scale of 2 : 1, its shield being shown both in front view and in cross-section.

The drawings must indicate the position which the component type-approval mark (particularly the type-approval number and the category reference[s]) is to occupy in the type-approval mark rectangle;
      - 1.2.2.3. in the case of filament lamps with colourless glass envelopes — five samples; in the case of filament lamps with coloured glass envelopes — one sample with a coloured glass envelope and five samples with colourless glass envelopes, the latter five differing from the former only in that the glass is not coloured. Where the type of filament lamp concerned differs only in respect of colour from a colourless type which has previously satisfied the tests referred to in sections 4 to 8 of Annex III, it will be sufficient to submit one sample with a coloured glass envelope, and the only tests to be made on this sample will be those referred to in section 9 of Annex III.
2. MARKINGS
  - 2.1. Headlamps which function as main-beam and/or dipped-beam headlamps
    - 2.1.1. Samples of a type of headlamp which functions as a main-beam and/or dipped-beam headlamp submitted for EEC component type-approval must bear the trade name or mark of the applicant.
    - 2.1.2. Each headlamp shall include on both the glass and the lamp housing a space of sufficient size for the EEC component type-approval mark.

If the glass cannot be separated from the main body of the headlamp, the provision of a marking area on the glass will suffice. This space must correspond to the one shown in the drawings mentioned in 1.2.1.3.

- 2.1.3. In the case of headlamps designed to meet the requirements of traffic moving on one side of the road only (either right or left), the area which can be occulted to prevent discomfort to users in a Member State where traffic moves on the opposite side of the road shall be outlined indelibly on the front glass. This marking is not necessary, however, where the area is clearly apparent from the design.
- 2.1.4. In the case of headlamps designed to satisfy the requirements both of Member States with right-hand traffic and of Member States with left-hand traffic, the two settings of the optical unit on the vehicle or of the filament lamp on the reflector shall be marked by the capital letters R and D, the right-hand traffic and L and G, for left-hand traffic.
- 2.2. **Filament lamps for headlamps which function as main-beam and/or dipped-beam headlamps**
- 2.2.1. Samples of a type of filament lamp for headlamps which function as main-beam and/or dipped-beam headlamps submitted for EEC component type-approval must bear the trade name of the applicant.
- 2.2.2. Each filament lamp shall include a space of sufficient size for the EEC component type-approval mark; this space must correspond to the one shown in the drawings mentioned in 1.2.2.2.
- 2.2.3. They shall at least indicate the nominal voltage, and the nominal wattage of the main-beam filament, followed by the nominal wattage of the dipped-beam filament.
- 2.3. Markings must be clearly legible and indelible.
3. **EEC COMPONENT TYPE-APPROVAL**
- 3.1. If all the samples submitted in accordance with section 1 meet the requirements of sections 5 and 6 of Annex I for headlamps and sections 5, 6, 7, 8, 9, 10 and 11 of Annex III for filament lamps, EEC component type-approval shall be granted and a component type-approval number assigned.
- 3.2. This number shall not be assigned to any other type of headlamp or filament lamp except in the case of the extension of EEC component type-approval to another type of headlamp or filament lamp differing only in the colour of the light emitted.
- 3.3. Where EEC component type-approval is requested for a type of lighting and light-signalling device comprising headlamps which function as main-beam and/or dipped-beam headlamps and other lamps, a single EEC component type-approval mark may be issued provided that the headlamps comply with the requirements of this Directive and that each of the other lamps forming part of the lighting and light-signalling device for which EEC component type-approval is requested complies with the specific Directive applying to it.
4. **MARKS**
- 4.1. All headlamps which function as main-beam and/or dipped-beam headlamps and all filament lamps for these headlamps conforming to a type approved under this Directive shall bear an EEC component type-approval mark.
- 4.2. This mark shall consist of a rectangle surrounding the lower case letter 'e', followed by the distinguishing letter(s) or number of the Member State which has granted the component type-approval:
- 1 for Germany,
  - 2 for France,
  - 3 for Italy,
  - 4 for the Netherlands,
  - 6 for Belgium,
  - 11 for the United Kingdom,
  - 13 for Luxembourg,
  - DK for Denmark,
  - IRL for Ireland.

It must also include the EEC component type-approval number corresponding to the number of the EEC component type-approval document issued for the type of headlamp or filament lamp concerned. In the case of a headlamp, this number shall be placed beneath the rectangle and, in the case of a filament lamp, near the rectangle.

- 4.3. For headlamps which function as main-beam and/or dipped-beam headlamps, the EEC component type-approval mark shall be supplemented by the following additional symbols:
  - 4.3.1. a horizontal arrow below the rectangle pointing to the right of an observer facing the headlamp, i.e. to the side of the road on which the traffic moves, on headlamps meeting the requirements of left-hand traffic only;
  - 4.3.2. A horizontal arrow below the rectangle with a head at each end, the heads pointing respectively to the left and to the right, on headlamps designed to meet the requirements of both traffic systems by means of selective setting of the optical unit or of the filament lamp;
  - 4.3.3. the letter 'C' set above the rectangle, on headlamps meeting the requirements of this Directive in respect of the dipped beam only;
  - 4.3.4. the letter 'R' set above the rectangle, on headlamps meeting the requirements of this Directive in respect of the main beam only;
  - 4.3.5. the letters 'CR' set above the rectangle, on headlamps meeting the requirements of this Directive in respect of both the dipped beam and the main beam.
- 4.4. The EEC component type-approval mark and the additional symbols must be affixed in such a way as to be indelible and clearly legible. In the case of a headlamp, they must be affixed on the lens of the lamp or on one of the lenses in such a way as to remain legible even when the headlamp is fitted on the vehicle.
- 4.5. Examples of the EEC component type-approval marks and additional symbols are shown in the Appendix.
- 4.6. Where a single EEC component type-approval number is issued for a type of lighting and light-signalling device comprising headlamps which function as main-beam and/or dipped-beam headlamps and other lamps, one EEC component type-approval mark only may be affixed, consisting of:
  - a rectangle surrounding the letter 'e' followed by the distinguishing letter(s) or number of the Member States which has granted the type-approval,
  - the EEC component type-approval number,
  - the additional symbols required by the various Directives under which EEC component type-approval was granted.
- 4.7. The dimensions of the various components of this mark must not be less than the largest of the minimum dimensions specified for individual markings by the various Directives under which the EEC component type-approval was granted.

## Appendix

## EXAMPLES OF THE EEC COMPONENT TYPE-APPROVAL MARKS

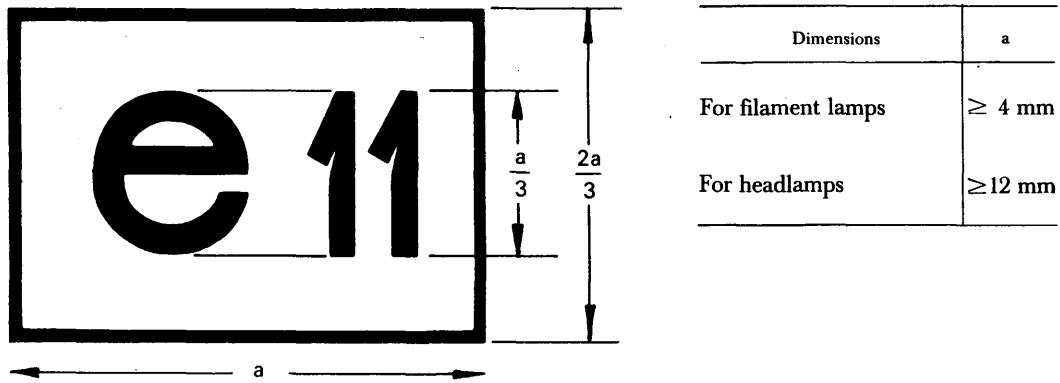

Figure 1

The device bearing the EEC component type-approval mark above is a headlamp EEC type-approved in the United Kingdom (e 11) under the number 1471.

*Note:*

Headlamps meeting the requirements of Annex I shall bear, in addition:

- the letters CR if they meet the requirements of Annex I with respect to both the dipped beam and the main beam (see figures 2, 3 und 4),
- the letter R if they meet the requirements of Annex I with respect to the main beam only (see figure 8).

In addition, if the headlamps are designed for left-hand traffic or, by means of selective setting of the optical unit or of the filament lamp, for both traffic systems, they shall display a horizontal arrow ending, in the first case, in a head directed to the right (see figures 3 and 7), and in the the second case in two heads, one directed to the right and one to the left (see figures 4 and 5).

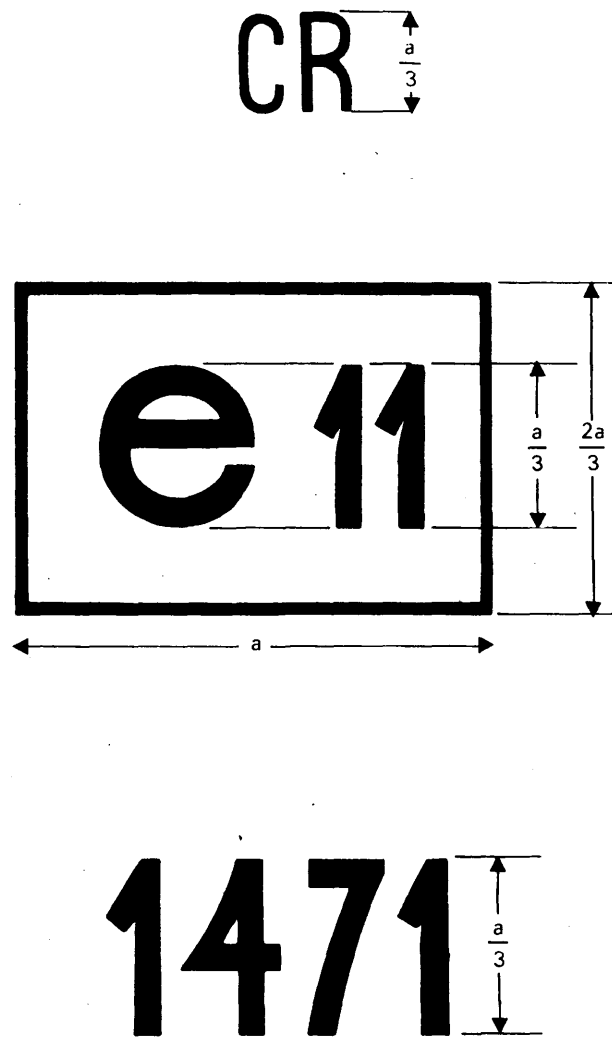
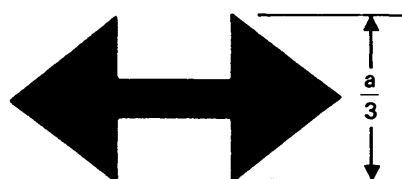
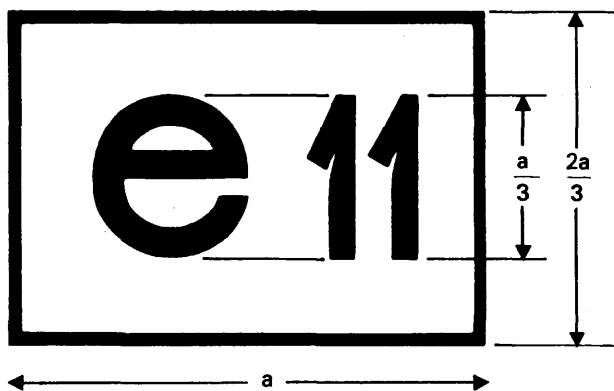
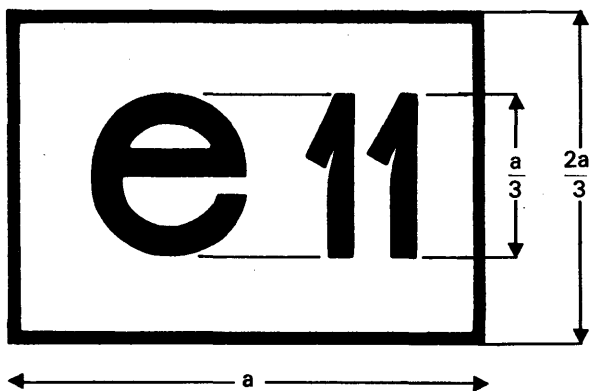

Figure 2

Identification of a headlamp meeting the requirements of Annex I with respect to both the dipped beam and the main beam and designed for right-hand traffic only.

CR 

CR 

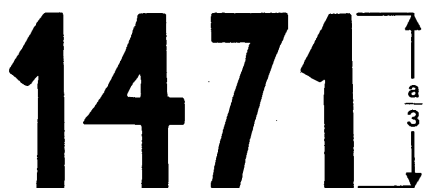

1471 

1471 

Figure 3

Identification of a headlamp meeting the requirements of Annex I with respect to both the dipped beam and the main beam and designed for left hand traffic only.

Figure 4

Identification of a headlamp meeting the requirements of Annex I with respect to both the dipped beam and the main beam and designed for both traffic systems, by means of selective setting of the optical unit or of the filament lamp.



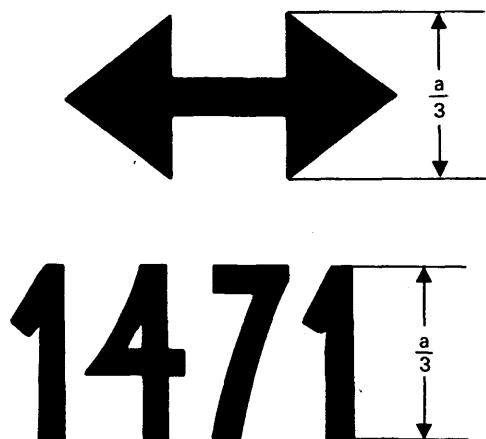
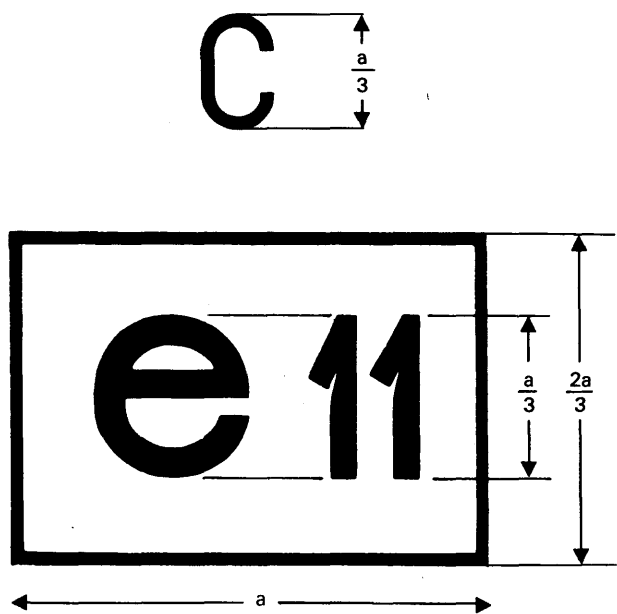

Figure 5

Identification of a headlamp meeting the requirements of Annex I with respect to the dipped beam only and designed for both traffic systems.

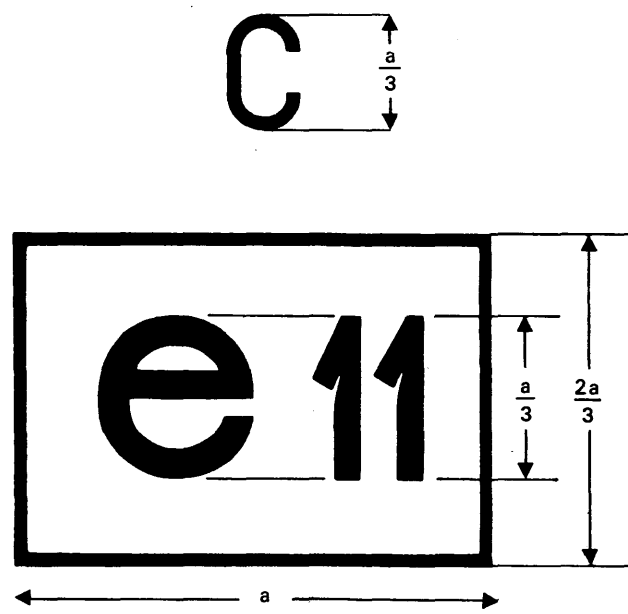

Figure 6

Identification of a headlamp meeting the requirements of Annex I with respect to the dipped beam only and designed for right-hand traffic only.

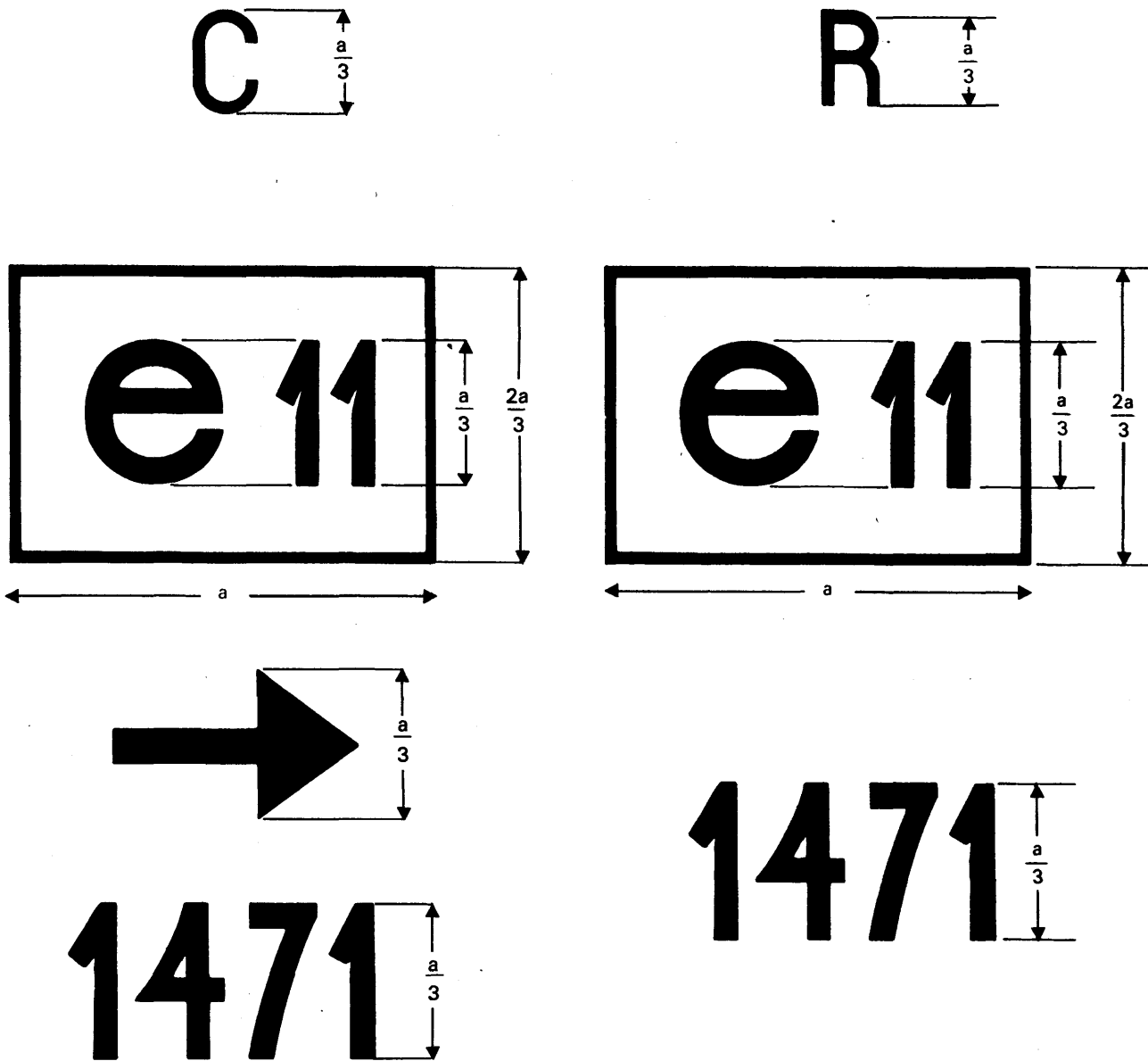

Figure 7

Identification of a headlamp meeting the requirements of Annex I with respect to the dipped beam only and designed for left-hand traffic only.

Figure 8

Identification of a headlamp meeting the requirements of Annex I with respect to the main beam only.