

This document is meant purely as a documentation tool and the institutions do not assume any liability for its contents

► **B****COUNCIL DIRECTIVE**

**of 28 June 1977**

**on the approximation of the laws of the Member States relating to the roll-over protection structures of wheeled agricultural or forestry tractors**

(77/536/EEC)

(OJ L 220, 29.8.1977, p. 1)

Amended by:

		Official Journal		
		No	page	date
► <b><u>M1</u></b>	Council Directive 87/354/EEC, of 25 June 1987	L 192	43	11.7.1987
► <b><u>M2</u></b>	Council Directive 89/680/EEC, of 21 December 1989	L 398	26	30.12.1989
► <b><u>M3</u></b>	Commission directive 1999/55/EC of 1 June 1999	L 146	28	11.6.1999
► <b><u>M4</u></b>	Council Directive 2006/96/EC of 20 November 2006	L 363	81	20.12.2006

Amended by:

► <b><u>A1</u></b>	Act of Accession of Greece	L 291	17	19.11.1979
► <b><u>A2</u></b>	Act of Accession of Spain and Portugal	L 302	23	15.11.1985
► <b><u>A3</u></b>	Act of Accession of Austria, Sweden and Finland (adapted by Council Decision 95/1/EC, Euratom, ECSC)	C 241 L 1	21 1	29.8.1994 1.1.1995
► <b><u>A4</u></b>	Act concerning the conditions of accession of the Czech Republic, the Republic of Estonia, the Republic of Cyprus, the Republic of Latvia, the Republic of Lithuania, the Republic of Hungary, the Republic of Malta, the Republic of Poland, the Republic of Slovenia and the Slovak Republic and the adjustments to the Treaties on which the European Union is founded	L 236	33	23.9.2003

**COUNCIL DIRECTIVE****of 28 June 1977****on the approximation of the laws of the Member States relating to the roll-over protection structures of wheeled agricultural or forestry tractors**

(77/536/EEC)

THE COUNCIL OF THE EUROPEAN COMMUNITIES,

Having regard to the Treaty establishing the European Economic Community, and in particular Article 100 thereof,

Having regard to the proposal from the Commission,

Having regard to the opinion of the European Parliament <sup>(1)</sup>,Having regard to the opinion of the Economic and Social Committee <sup>(2)</sup>,Whereas the technical requirements with which tractors must comply pursuant to national laws relate *inter alia* to roll-over protection structures and to their attachment to the tractor;Whereas those requirements differ from one Member State to another; whereas it is therefore necessary that all Member States adopt the same requirements either in addition to or in place of their existing rules in order, in particular, to allow the EEC type-approval procedure which was the subject of Council Directive 74/150/EEC of 4 March 1974 on the approximation of the laws of the Member States relating to the type-approval of wheeled agricultural or forestry tractors <sup>(3)</sup>, to be applied in respect of each type of tractor;

Whereas a harmonized component type-approval procedure for roll-over protection structures and their attachment to the tractor makes it possible for each Member State to check compliance with the common construction and testing requirements and to inform the other Member States of its findings by sending a copy of the component type-approval certificate completed for each type of roll-over protection structure and its attachment to the tractor; whereas the placing of an EEC-component type-approval mark on all structures manufactured in conformity with the approved type obviates any need for technical checks on those structures in the other Member States;

Whereas common requirements concerning other elements and characteristics of the roll-over protection structure, in particular those concerning the dimensions, doors, safety glass, devices to prevent continuous rolling if the tractor overturns, and protection of passengers, will be laid down at a later date;

Whereas the harmonized requirements are intended principally to ensure safety on the road and at work throughout the Community; whereas for this reason it is necessary to introduce the obligation for tractors covered by this Directive to be fitted with roll-over protection structures;

Whereas the approximation of the national laws relating to tractors entails reciprocal recognition by Member States of the checks carried out by each of them on the basis of the common requirements,

<sup>(1)</sup> OJ No C 76, 7. 4. 1975, p. 37.<sup>(2)</sup> OJ No C 263, 17. 11. 1975, p. 58.<sup>(3)</sup> OJ No L 84, 28. 3. 1974, p. 10.

**▼B**

HAS ADOPTED THIS DIRECTIVE:

*Article 1*

1. Each Member State shall grant EEC component type-approval for any type of roll-over protection structure and its tractor attachment which satisfies the construction and testing requirements laid down in Annexes I, II, III, IV and V hereto.

2. The Member State which has granted EEC component type-approval shall take the measures required to verify, in so far as is necessary and if need be in cooperation with the competent authorities in the other Member States, that production models conform to the approved type. Such verification shall be limited to spot checks.

*Article 2*

Member States shall for each type of roll-over protection structure and its tractor attachment which they approve pursuant to Article 1, issue to the manufacturer of the tractor or of the roll-over protection structure or to his authorized representative, an EEC component type-approval mark conforming to the model shown in Annex VI hereto.

Member States shall take all appropriate measures to prevent the use of marks liable to create confusion between roll-over protection structures which have been component type-approved pursuant to Article 1 and other devices.

*Article 3*

1. No Member State may prohibit the placing on the market of roll-over protection structures or their tractor attachment on grounds relating to their construction if they bear the EEC component type-approval mark.

2. Nevertheless, a Member State may prohibit the placing on the market of roll-over protection structures bearing the EEC component type-approval mark which consistently fail to conform to the approved type.

That State shall forthwith inform the other Member States and the Commission of the measures taken, specifying the reasons for its decision.

*Article 4*

The competent authorities of each Member State shall within one month send to the competent authorities of the other Member States a copy of the component type-approval certificates, an example of which is given in Annex VII, completed for each type of roll-over protection structure which they approve or refuse to approve.

*Article 5*

1. If the Member State which has granted EEC component type-approval finds that a number of roll-over protection structures and their tractor attachments bearing the same EEC component type-approval mark do not conform to the type which it has approved, it shall take the necessary measures to ensure that production models conform to the approved type. The competent authorities of that State shall advise those of the other Member States of the measures taken which may, is necessary, where there is serious and repeated failure to conform, extend to withdrawal of EEC component type-approval. The said authorities shall take the same measures if they are informed by the

**▼B**

competent authorities of another Member State of such failure to conform.

2. The competent authorities of the Member States shall within one month inform each another of any withdrawal of EEC component type-approval and of the reasons for any such measure.

*Article 6*

Any decision taken pursuant to the provisions adopted in implementation of this Directive to refuse or withdraw component type-approval for roll-over protection structures and their tractor attachments, or to prohibit their placing on the market or their use, shall set out in detail the reasons on which it is based. Such decision shall be notified to the party concerned, who shall at the same time be informed of the remedies available to him under the laws in force in the Member States and of the time limits allowed for the exercise of such remedies.

*Article 7*

No Member State may refuse to grant EEC type-approval or national type-approval in respect of a tractor on grounds relating to roll-over protection structures or their tractor attachments if these bear the EEC component type-approval mark and if the requirements laid down in Annex VIII have been satisfied.

*Article 8*

No Member State may refuse or prohibit the sale, registration, entry into service or use of any tractor on grounds relating to the roll-over protection structure and its tractor attachment if these bear the EEC component type-approval mark and if the requirements laid down in Annex VIII have been met.

*Article 9*

This Directive shall apply to tractors defined in Article 1 of Directive 74/150/EEC having the following characteristics:

- clearance beneath the rear axle of not more than 1 000mm,
- fixed or adjustable track width of one of the driving axles of 1 150 mm or more,
- possibility of being fitted with a multipoint coupling device for detachable tools and a draw bar,
- ►M2 mass between 1·5 and 6 tonnes ◀, corresponding to the unladen weight of the tractor, as defined in item 2·4 of Annex I to Directive 74/150/EEC, including the roll-over protection structure fitted in compliance with the present Directive and tyres of the largest size recommended by the manufacturer.

*Article 10*

In the context of EEC type-approval any tractor to which Article 9 refers must be fitted with a roll-over protection structure which satisfies the requirements laid down in Annexes I, II, III and IV.

**▼B**

*Article 11*

Any amendments necessary to adjust the requirements of the Annexes to this Directive to take account of technical progress shall be adopted in accordance with the procedure laid down in Article 13 of Directive 74/150/EEC.

*Article 12*

1. Member States shall bring into force the provisions necessary in order to comply with this Directive within 18 months of its notification and shall forthwith inform the Commission thereof.
2. Member States shall ensure that the texts of the main provisions of national law which they adopt in the field covered by this Directive are communicated to the Commission.

*Article 13*

This Directive is addressed to the Member States.

**▼B****LIST OF ANNEXES**

ANNEX I:	Conditions for EEC component type-approval
ANNEX II:	Conditions for testing the strength of the roll-over protection structures and of their attachment to tractors
ANNEX III:	Test procedures
ANNEX IV:	Figures
ANNEX V:	Test report model
ANNEX VI:	Marks
ANNEX VII:	Model of EEC component type-approval certificate
ANNEX VIII:	Conditions for EEC type-approval
ANNEX IX:	Annex to the EEC type-approval certificate for a tractor with regard to the strength of the roll-over protection structures as well as of their attachment to the tractor.

**▼B**

## ANNEX I

**CONDITIONS FOR EEC COMPONENT TYPE-APPROVAL**

1. DEFINITION
  - 1.1. A *roll-over protection structure* (safety cab or frame) means the structure on a tractor the essential purpose of which is to avoid or limit risks to the driver resulting from roll-over of the tractor during normal use.
  - 1.2. The structures mentioned in 1.1 are characterized by the fact that, in the event of roll-over, they ensure an unobstructed space inside them large enough to protect the driver.
2. GENERAL REQUIREMENTS
  - 2.1. Every roll-over protection structure and its attachment to a tractor must be so designed and constructed as to fulfil the essential purpose laid down in 1.
  - 2.2. This requirement shall be checked by one of the two test methods described in Annex III. The method chosen shall take account of the tractor mass as follows:
    - for tractors of mass specified by Article 9 — Annex III B,
    - for tractors of mass more than 1·5 tonnes and not more than 3·5 tonnes — Annex III A,

**▼M3**

- as regards tractors with a reversible driving position (i.e. with a reversible seat and steering wheel) or fitted with optional seats, only the testing method described in part B of Annex III shall apply.

**▼B**

3. APPLICATION FOR EEC COMPONENT TYPE-APPROVAL
  - 3.1. The application for EEC component type-approval with regard to the strength of a roll-over protection structure and the strength of its attachment to a tractor shall be submitted by the tractor manufacturer or by the manufacturer of the roll-over protection structure or by their authorized representatives.
  - 3.2. The application for EEC component type-approval shall be accompanied by the undermentioned documents in triplicate and by the following particulars:
    - general arrangement drawing either to a scale marked on the drawing or giving the main dimensions of the roll-over protection structure. This drawing must in particular show details of the mounting components,
    - photographs from side and rear showing mounting details,
    - brief description of the roll-over protection structure including type of construction, details of mounting on the tractor and, where necessary, details of cladding, means of access and escape, details of interior padding and features to prevent continuous rolling and details of heating and ventilation,
    - details of materials used in structural parts including attaching brackets and fixing bolts (see Annex V).
  - 3.3. A tractor representative of the tractor type for which the protection structure to be approved is intended shall be submitted to the technical service responsible for conducting the component type-approval tests. This tractor shall be fitted with the roll-over protection structure.
  - 3.4. The holder of EEC component type-approval may request its extension to other tractor types. The competent authority which has granted the original EEC component type-approval shall grant the extension if the approved roll-over protection structure and the type(s) of tractor for which the extension is requested comply with the following conditions:
    - the mass of the unballasted tractor, as defined in 1.3 of Annex II, does not exceed by more than 5 % the reference mass used in the test,

**▼B**

- the method of attachment and the tractor's components to which the attachments are made are identical,
- any components such as mudguards and bonnet cowls which may provide support for the roll-over protection device are identical,
- the position of the seat has not been changed.

**4. MARKINGS**

- 4.1. Every roll-over protection structure conforming to the approved type shall bear the following markings:
  - 4.1.1. the trade mark or name;
  - 4.1.2. a component type-approval mark conforming to the model in Annex VI;
  - 4.1.3. serial number of the protection structure;
  - 4.1.4. make and type(s) of tractor(s) for which the protection structure is intended.
- 4.2. All these particulars must appear on a small plate.
- 4.3. These markings must be visible, legible and indelible.





*ANNEX II*

**CONDITIONS FOR TESTING THE STRENGTH OF A ROLL-OVER PROTECTION STRUCTURE AND OF ITS ATTACHMENT TO A TRACTOR**

1. GENERAL REQUIREMENTS

1.1. **Test purposes**

Tests made using special rigs are intended to simulate such loads as are imposed on a roll-over protection structure when a tractor overturns. These tests, described in Annex III, must enable the strength of the roll-over protection structure and the attaching brackets to the tractor to be assessed.

1.2. **Preparation for test**

1.2.1. A roll-over protection structure must be tested on a tractor of the type for which it is designed. It must be attached to the tractor in accordance with the instructions of the manufacturer of the tractor and/or those of the manufacturer of the roll-over protection structure.

1.2.2. For the tests a tractor must be fitted with all structural components of the series production which may influence the strength of the roll-over protection structure or which may be necessary for the strength test.

Components which may create a hazard in the zone of clearance must also be fitted so that they may be examined as to their compliance with the requirements of 4.1 of this Annex.

1.2.3. Tests shall be made with the tractor stationary.

1.3. **Tractor mass**

The measured mass  $W$  used in the formulae (see Annex III A and III B) to calculate the height of the fall of the pendulum weight and the crushing force, shall be at least that defined in 2.4 of Annex I to Directive 74/150/EEC (i.e., excluding optional accessories but including coolant, oils, fuel, tools and driver) plus the roll-over protection structure and less 75 kg. Not included are optional front or rear ballast weights, tyre ballast, mounted implements, mounted equipment or any specialized components.

2. APPARATUS AND EQUIPMENT

2.1. **Pendulum weight**

2.1.1. A pendulum weight shall be suspended by two chains or wire ropes from pivot points not less than 6 m above the ground. Means shall be provided for adjusting independently the suspended height of the weight and the angle between the weight and the supporting chains or wire ropes.

2.1.2. The weight shall be  $2\,000 \pm 20$  kg excluding the weight of the chains or wire ropes which themselves shall not exceed 100 kg. The length of the sides of the impact face shall be  $680 \pm 20$  mm (see Annex IV, fig. 4). The weight shall be filled in such a way that the position of its centre of gravity is constant.

2.1.3. Means shall be provided of pulling the weight back as a pendulum to a height which is determined for each test. A quick-release mechanism shall allow the weight to swing downwards without altering the tilt in relation to the supporting chains or wire ropes.

2.2. **Pendulum supports**

The pendulum pivot points shall be rigidly fixed so that their displacement in any direction does not exceed 1 % of the height of fall.

2.3. **Lashings**

2.3.1. The tractor shall be lashed by means of restraining and tensioning devices to ground rails rigidly attached to a non-yielding concrete base. The rails shall be suitably spaced to enable the tractor to be lashed down as illustrated in Annex IV, figs. 5, 6 and 7. For each test the tractor wheels and any axle stands used shall rest on the non-yielding base.

**▼B**

- 2.3.2. Apart from the tensioning devices and ground rail attachments the tractor shall be lashed down with wire rope of the dimensions specified.

This wire rope shall be any round strand, fibre core, construction  $6 \times 19$  in accordance with ISO 2408. The nominal rope diameter shall be 13 mm.

- 2.3.3. The central pivot of an articulated tractor shall be supported and lashed down as appropriate for the front, rear and side impacts and for the crushing tests and shall, in addition, be propped from the side for the side impact. The front and rear wheels need not be in line if this makes it more convenient to attach appropriate wire ropes.

**2.4. Wheel prop and beam**

- 2.4.1. A beam shall be used as a prop for the wheel in the side impact as shown in Annex IV, fig. 7.

- 2.4.2. A softwood beam of approximately 150 mm square shall be clamped to the floor to brace the tyres on the side opposite the impact as shown in Annex IV, figs. 5, 6 and 7.

**2.5. Props and lashings for articulated tractors**

- 2.5.1. Additional props and lashings shall be used for articulated tractors. Their purpose is to ensure that the section of the tractor on which the roll-over protection structure is fitted is as rigid as that of a rigid tractor.

- 2.5.2. Additional specific details are given in Annex III for the impact and crushing tests.

**2.6. Crushing rig**

A rig as shown in Annex IV, fig. 8, shall be capable of exerting a downward force on a roll-over protection structure through a rigid beam approximately 250 mm wide connected to the load-applying mechanism by means of universal joints. Suitable axle stands shall be provided so that the tractor tyres do not bear crushing force.

**2.7. Measuring apparatus**

- 2.7.1. For the tests laid down in Annex III A and III B a device must be used on which a moving friction collar is tightly fitted on a horizontal rod for the purpose of measuring the difference between maximum momentary deflection and residual deflection during a side impact test.

- 2.7.2. For the tests laid down in Annex III A, measurements shall be made after the laboratory test to determine whether any part of the protection structure has entered the zone of clearance prescribed in 2 of Annex III A.

- 2.7.3. For the tests laid down in Annex III B, equipment must be provided — which may include photographic equipment — so that after the laboratory tests it may be established whether any part of the protection structure has, during these tests, entered or come into contact with the zone of clearance prescribed in 2 of Annex III B.

**2.8. Measurement tolerances**

The following tolerances shall apply to measurements made during the tests:

- 2.8.1. linear dimensions measured during test (except 2.8.2); protection structure and tractor dimensions, zone of clearance and tyre deflections when lashed for impact tests:  $\pm 3$  mm;
- 2.8.2. height of pendulum weight set for impact tests:  $\pm 6$  mm;
- 2.8.3. measured tractor mass:  $\pm 20$  kg;
- 2.8.4. load applied in crushing tests:  $\pm 2$  %
- 2.8.5. angle of weight-supporting chains or wire ropes at the point of impact:  $\pm 2^\circ$ .

**▼ B**

## 3. TESTS

## 3.1. General requirements

## 3.1.1. Sequence of tests

3.1.1.1. The list and sequence of tests shall be as follows. The item numbers are those in which the tests are described in Annex III A and III B:

1. impact from the rear:	1.1,
2. crushing test at the rear:	1.4,
3. impact from the front:	1.2,
4. impact from the side:	1.3,
5. crushing test at the front:	1.5.

3.1.1.2. If, during the test, any part of the restraining equipment moves or breaks, the test shall be repeated.

3.1.1.3. No repairs or adjustments to the tractor or roll-over protection structure may be carried out during the test.

3.1.1.4. The tractor gear-box shall be in neutral and the brakes off throughout the test.

**▼ M3**

3.1.1.5. In the case of a tractor with a reversible driving position (i.e. with a reversible seat and steering wheel), the first impact shall be longitudinal and shall be applied at the heaviest extremity (with more than 50 % of the mass of the tractor). It shall be followed by a crushing test at the same extremity. The second impact shall be on the lightest extremity, and the third impact shall be from the side. Lastly, a second crushing test shall be carried out on the lightest extremity.

**▼ B**

## 3.1.2. Track width

A track width setting for the rear wheels shall be chosen such that as far as possible the roll-over protection structure is not supported by the tyres during the tests.

## 3.1.3. Removal of non-hazard-creating components

All components of the tractor and roll-over protection structure which, as complete units, constitute protection for the driver — including weather protection — shall be supplied with the tractor to be tested. It is permissible to remove front, side and rear windows of safety glass or similar material and any detachable panels, fittings and accessories which have no function of structural strength and which cannot create a hazard in the event of overturning.

## 3.1.4. Direction of impacts

The side of the tractor on which the side impact is truck shall be that which is likely to give the greatest distortion. The rear impact shall be on the corner furthest from the side impact, and the front impact on the corner nearest the side impact.

## 3.1.5. Tyre pressures and deflections

Tyres shall not be water ballasted. Pressures and deflections in those tyres which are lashed in the various tests shall be in accordance with the following table:

	Tyre pressure (bar)				Deflection (mm)	
	Radial-ply tyres		Diagonal-ply tyres		Front	Rear
	Front	Rear	Front	Rear		
Four-wheel drive, front and rear wheels of the same size	1·20	1·20	1·00	1·00	25	25
Four-wheel drive, front wheels smaller than rear	1·80	1·20	1·50	1·00	20	25
Two-wheel drive	2·40	1·20	2·00	1·00	15	25

**▼B**

4. INTERPRETATION OF RESULTS
  - 4.1. A roll-over protection structure submitted for EEC component type-approval shall be considered as having satisfied requirements concerning strength if it fulfils the following conditions:
    - 4.1.1. it is free from fractures and cracks as described in 3.1 of Annex III A and III B;
    - 4.1.2. for Annex III A tests: no part of the zone of clearance is outside the roll-over protection structure;  
for Annex III B tests: no part of the zone of clearance has been entered by the roll-over protection structure during any of the impact or crushing tests or is outside the roll-over protection structure, as described in 3.2 of Annex III B;
    - 4.1.3. for Annex III A tests: the difference between the maximum momentary deflection and residual deflection, referred to in 3.3 of Annex III A, does not exceed 15 cm;  
For Annex III B tests: during the side impact test the difference between the maximum momentary deflection and the residual deflection, referred to in 3.3 of Annex III B does not exceed 25 cm.
  - 4.2. There is no other feature presenting a particular hazard to the driver e.g. glass of a type likely to shatter dangerously, insufficient padding inside the roof or where the driver's head may strike.
5. TEST REPORT
  - 5.1. The test report shall be attached to the EEC component type-approval certificate referred to in Annex VII. The presentation of the report shall be as shown in Annex V. The report shall include:
    - 5.1.1. a general description of the roll-over protection structure's shape and construction including materials and fixings; external dimensions of tractor with protection structure fitted; main interior dimensions; minimum clearance from steering wheel; lateral distance from steering wheel to protection structure sides; height of protection structure roof above seat or seat reference point and above foot platform if there is one; details of provisions for normal entry and exit and for escape as determined by the protection structure parts; and details of heating and, where appropriate, ventilation system;
    - 5.1.2. details of any special features such as devices to prevent the continuous rolling of the tractor;
    - 5.1.3. a brief description of any interior padding intended to minimize head or shoulder injuries or to effect noise reduction;
    - 5.1.4. a statement of the type of windscreen and glazing fitted.
  - 5.2. The report must identify clearly the tractor type (make, type, commercial description, etc.) used for testing and the types for which the roll-over protection structure is intended.
  - 5.3. If EEC component type-approval is being extended for other tractor types, the report must include the exact reference of the report of the original EEC component type-approval as well as precise indications regarding the requirements laid down in 3.4 of Annex I.



*ANNEX III*

**TEST PROCEDURES**

A — TEST METHOD I

1. IMPACT AND CRUSHING TESTS

1.1. **Impact at the rear**

- 1.1.1. The tractor shall be so placed in relation to the weight that the weight will strike the roll-over protection structure when the impact face of the weight and the supporting chains or wire ropes are at an angle of 20° to the vertical unless the roll-over protection structure at the point of contact has, during deflection, a greater angle to the vertical. In this case the impact face of the weight shall be adjusted by means of an additional support so that it is parallel to the roll-over protection structure at the point of impact at the moment of maximum deflection, the supporting chains or wire ropes remaining at an angle of 20° to the vertical. Steps must be taken to reduce the tendency of the weight to turn about the point of contact. The suspended height of the weight shall be so adjusted that the locus of its centre of gravity passes through the point of contact.

The point of impact shall be that part of the roll-over protection structure likely to hit the ground first in a rearward overturning accident, normally the upper edge. The position of the centre of gravity of the weight shall be one-sixth of the width of the top of the roll-over protection structure inwards from a vertical plane parallel to the median plane of the tractor touching the outside extremity of the top of the roll-over protection structure.

However, if a curve in the back of the roll-over protection structure starts at a greater distance than this inside this vertical plane, the impact shall be administered at the beginning of the curve, i.e. at the point where this curve is tangential to a line at right angles to the median plane of the tractor (see Annex IV, fig. 9).

If a protruding member would present an inadequate area for the weight, a steel plate of appropriate thickness and depth and about 300 mm in length shall be fastened to that member in such a manner that the strength of the roll-over protection structure is not affected.

- 1.1.2. Tractors with rigid bodies shall be lashed down. The points of attachment of the lashings shall be approximately 2 m behind the rear axle and 1.5 m in front of the front axle. They shall either be in the plane in which the centre of gravity of the pendulum will swing or more than one lashing shall give a resultant force in this plane, as in Annex IV, fig. 5.

The lashings shall be tightened so that the deflections in the front and rear tyres are as indicated in 3.1.5 of Annex II. When the lashings have been tightened, a wooden beam 150 mm square shall be clamped in front of the rear wheels and driven tight against them.

- 1.1.3. Articulated tractors shall have both axles lashed down. The axle of that section of the tractor on which the roll-over protection structure is mounted shall be treated as the rear axle in Annex IV, fig. 5. The point of articulation will then be supported by a beam 100 mm square and will be lashed down firmly by means of wire ropes attached to the ground rails.

- 1.1.4. The weight shall be pulled back so that the height of its centre of gravity above that at the point of impact is given by the formula:

$$H = 125 + 0.020 W$$

where H is the height of fall in millimetres and W the mass of the tractor as defined in 1.3 of Annex II.

The weight shall then be released and allowed to crash against the roll-over protection structure.

1.2. **Impact at the front**

- 1.2.1. The tractor shall be so placed in relation to the weight that the weight will strike the roll-over protection structure when the impact face of the weight and the supporting chains or wire ropes are at an angle of 20° to the vertical unless the roll-over protection structure at the point of contact has, during deflection, a greater angle to the vertical. In this case the

**▼B**

impact face of the weight shall be adjusted by means of an additional support so that it is parallel to the roll-over protection structure at the point of impact at the moment of maximum deflection, the supporting chains or wire ropes remaining at an angle of 20° to the vertical. Steps must be taken to reduce the tendency of the weight to turn about the point of contact. The suspended height of the weight shall be so adjusted that the locus of its centre of gravity passes through the point of contact.

The point of impact shall be that part of the roll-over protection structure likely to hit the ground first if the tractor overturned sideways whilst travelling forward, normally the top front corner. The position of the centre of gravity of the weight shall be not more than 80 mm from a vertical plane parallel to the median plane of the tractor touching the outside extremity of the top of the roll-over protection structure.

However, if a curve in the front of the roll-over protection structure starts at a greater distance than 80 mm inside this vertical plane, the impact shall be administered at the beginning of the curve, i.e. at the point where this curve is tangential to a line at right angles to the median plane of the tractor (see Annex IV, fig. 9).

- 1.2.2. Tractors with rigid bodies shall be lashed down as indicated in Annex IV, fig. 6. The points of attachment of the lashings shall be approximately 2 m behind the rear axle and 1.5 m in front of the front axle.

The lashings shall be tightened so that the deflections in the front and rear tyres are as indicated in 3.1.5 of Annex II. When the lashings have been tightened, a wooden beam approximately 150 mm square shall be clamped behind the rear wheels and driven tight against them.

- 1.2.3. Articulated tractors shall have both axles lashed down. The axle of that section of the tractor on which the roll-over protection structure is mounted shall be treated as the front axle in Annex IV, fig. 6. The point of articulation shall then be supported by a beam approximately 100 mm square and shall be lashed down firmly by means of wire ropes attached to the ground rails.

- 1.2.4. The weight shall be pulled back so that the height of its centre of gravity above that at the point of impact is given by the formula:

$$H = 125 + 0.020 W.$$

1.3. **Impact at the side**

- 1.3.1. The tractor shall be so placed in relation to the weight that the weight will strike the roll-over protection structure when the impact face of the weight and the supporting chains or wire ropes are vertical unless the protection structure at the point of contact is, during deflection, other than vertical. In this case the impact face of the weight shall be adjusted by means of an additional support so that it is parallel to the protection structure at the point of impact at the moment of maximum deflection, the supporting chains or wire ropes remaining vertical. The suspended height of the weight shall be so adjusted that the locus of its centre of gravity passes through the point of contact.

The point of impact shall be that part of the roll-over protection structure likely to hit the ground first in a sideways overturning accident, normally the upper edge. Unless it is certain that another part of this edge would hit the ground first, the point of impact shall be in the plane at right angles to the median plane of the tractor and passing through the middle of the seat at the mid-point of adjustment. Steps must be taken to reduce the tendency of the weight to turn about the point of contact.

- 1.3.2. For rigid tractors, any axle the position of which is rigid relative to the protection structure shall be lashed down on the side on which the impact is to be administered. In the case of a two-wheel drive tractor this will normally be the rear axle; this arrangement is shown in Annex IV, fig. 7. The two lashings shall pass over the axle from points directly below it, one passing to a point of attachment approximately 1.5 m in front of the axle and the other to a point approximately 1.5 m behind the axle. The lashings shall be tightened so that there is a deflection in the tyre adjacent to the lashing as indicated in 3.1.5 of Annex II. After lashing, a wooden beam shall be placed as a prop against the wheel opposite the weight and secured to the floor so that it is held tightly against the wheel rim during impact as shown in Annex IV, fig. 7. The length of the beam shall be chosen so that when in position against the

**▼B**

wheel it is at an angle of  $30 \pm 3^\circ$  to the horizontal. Its length shall be 20 to 25 times its thickness and its width two to three times its thickness. Both axles shall be prevented from moving sideways by means of a beam clamped to the floor against the outside of the wheel on the side opposite that on which the impact is to be administered.

- 1.3.3. An articulated tractor must be lashed down so that the section of the tractor bearing the protection structure is fixed rigidly to the ground as in the case of a non-articulated tractor.

Both axles of articulated tractors shall be lashed to the ground. The axle and wheels of that section of the tractor on which the protection structure is mounted shall be lashed and propped as in Annex IV, fig. 7. The point of articulation shall be supported by a beam at least 100 mm square and lashed down to the ground rails. A prop will be positioned against the point of articulation and secured to the floor so that it has the same effect as a prop against the rear wheel and provides support similar to that achieved for a rigid tractor.

- 1.3.4. The weight shall be pulled back so that the height of its centre of gravity above that at the point of impact is given by the formula:

$$H = 125 + 0.150 W.$$

1.4. **Crushing at the rear**

The tractor shall be positioned in the rig described in 2.6 of Annex II and shown in Annex IV, figs. 8 and 10, in such a way that the rear edge of the beam is over the rearmost top load-bearing part of the protection structure and the median longitudinal plane of the tractor is midway between the points of application of force to the beam.

The axle stands shall be placed under the axles in such a way that the tyres do not bear the crushing force. The force applied shall correspond to twice the mass of the tractor as defined in 1.3 of Annex II. It may be necessary to lash down the front of the tractor.

1.5. **Crushing at the front**

- 1.5.1. This shall be identical to the crushing test at the rear except that the front edge of the beam shall be over the frontmost top part of the roll-over protection structure.

- 1.5.2. Where the front part of the protection structure roof will not sustain the full crushing force, the force shall be applied until the roof is deflected to coincide with the plane joining the upper part of the roll-over protection structure with that part of the front of the tractor capable of supporting the tractor's mass when overturned. The force shall then be removed and the tractor re-positioned so that the beam is over that point of the protection structure which would then support the rear of the tractor when completely overturned, as shown in Annex IV, fig. 10, and the full force reapplied.

2. **ZONE OF CLEARANCE**

- 2.1. The 'zone of clearance' is defined by planes as follows, the tractor being on a horizontal surface:

- horizontal, 95 cm above the compressed seat;
- vertical, perpendicular to the median plane of the tractor and 10 cm behind the back of the seat;
- vertical, parallel to the median plane of the tractor and 25 cm to the left of the centre of the seat;
- vertical, parallel to the median plane of the tractor and 25 cm to the right of the centre of the seat;
- an inclined plane in which lies a horizontal line which is at right angles to the median plane of the tractor, 95 cm above the compressed seat and 45 cm (plus the normal fore and aft movement of the seat) in front of the back of the seat. This inclined plane passes in front of the steering wheel and at its nearest point is 4 cm from the rim of the steering wheel.

- 2.2. The back of the seat shall be determined ignoring any padding thereon. The seat shall be in its rearmost adjustment for normal seated operation of the tractor and in its highest position if this is independently variable.

**▼B**

Where the suspension of the seat is adjustable it shall be at its mean setting and the load on it shall be 75 kg.

3. MEASUREMENTS TO BE MADE

3.1. **Fractures and cracks**

After each test all structural members, joints and attaching brackets on the tractor shall be visually examined for fractures or cracks, any small cracks in unimportant parts being ignored.

3.2. **Zone of clearance**

3.2.1. After each test the roll-over protection structure shall be examined to see whether any part of the protection structure has entered a zone of clearance round the driving seat as defined in 2.

3.2.2. In addition, the protection structure shall be examined to determine whether any part of the zone of clearance is outside the protection of the protection structure. For this purpose it shall be considered to be outside the protection of the structure if any part of it would have come in contact with flat ground if the tractor had overturned towards the direction from which the impact came. For this purpose the tyre and track setting shall be assumed to be the smallest indicated by the manufacturer.

3.3. **Maximum momentary deflection**

During the side impact test the difference between the maximum momentary deflection and the residual deflection at a height of 950 mm above the loaded seat shall be recorded. One end of the rod described in 2.7.1 of Annex II shall be attached to the upper part of the roll-over protection structure and the other end passed through a hole in the vertical standard. The position of the friction collar on the rod after the impact indicates the maximum momentary deflection.

3.4. **Permanent deflection**

After the final compression test the permanent deflection of the protection structure shall be recorded. For this purpose, before the start of the test, the positions of the main roll-over protection structure members in relation to the seat shall be recorded.

B — TEST METHOD II

1. IMPACT AND CRUSHING TESTS

1.1. **Impact at the rear**

1.1.1. The tractor shall be so placed in relation to the weight that the weight will strike the roll-over protection structure when the impact face of the weight and the supporting chains or wire ropes are at an angle of 20° to the vertical unless the roll-over protection structure at the point of contact has, during deflection, a greater angle to the vertical. In this case the impact face of the weight shall be adjusted by means of an additional support so that it is parallel to the roll-over protection structure at the point of impact at the moment of maximum deflection, the supporting chains or wire ropes remaining at an angle of 20° to the vertical. Steps must be taken to reduce the tendency of the weight to turn about the point of contact. The suspended height of the weight shall be so adjusted that the locus of its centre of gravity passes through the point of contact.

The point of impact shall be that part of the roll-over protection structure likely to hit the ground first in a rearward overturning accident, normally the upper edge. The position of the centre of gravity of the weight shall be one-sixth of the width of the top of the roll-over protection structure inwards from a vertical plane parallel to the median plane of the tractor touching the outside extremity of the top of the roll-over protection structure.

However, if a curve in the back of the roll-over protection structure starts at a greater distance than this inside this vertical plane, the impact shall be administered at the beginning of the curve, i.e. at the point where this curve is tangential to a line at right angles to the median plane of the tractor (see Annex IV, fig. 9).

If a protruding member would present an inadequate area for the weight, a steel plate of appropriate thickness and depth and about 300 mm in



**▼B**

length shall be fastened to that member in such a manner that the strength of the roll-over protection structure is not affected.

- 1.1.2. Tractors with rigid bodies shall be lashed down. The points of attachment of the lashings shall be approximately 2 m behind the rear axle and 1.5 m in front of the front axle. They shall either be in the plane in which the centre of gravity of the pendulum will swing or more than one lashing shall give a resultant force in this plane, as in Annex IV, fig. 5.

The lashing shall be tightened so that the deflections in the front and rear tyres are as indicated in 3.1.5 of Annex II. After the lashings have been tightened a wooden beam 150 mm square shall be clamped in front of the rear wheels and driven tight against them.

- 1.1.3. Articulated tractors shall have both axles lashed down. The axle for that section of the tractor on which the roll-over protection structure is mounted shall be treated as the rear axle in Annex IV, fig. 5. The point of articulation will then be supported by a beam 100 mm square minimum and will be lashed down firmly by means of wire ropes attached to the ground rails.

- 1.1.4. The weight shall be pulled back so that the height of its centre of gravity above that at the point of impact is given by the formula:

$$H = 2 \cdot 165 \times 10^{-8} \times WL^2 \text{ or } H = 5 \cdot 73 \times 10^{-2} \times I$$

where:

H = the height of fall in millimetres,

W = the mass of the tractor as defined in 1.3 of Annex II,

L = the maximum tractor wheelbase in millimetres,

I = the moment of inertia of the rear axle, with wheels removed, in kilograms per square metre (kg/m<sup>2</sup>).

The weight shall then be released and allowed to crash against the roll-over protection structure.

- 1.1.5. There shall be no rear impact in the case of a tractor at least 50 % of the mass of which, as defined in 1.3 of Annex II, bears on the front axle.

## 1.2. Impact at the front

- 1.2.1. The tractor shall be so placed in relation to the weight that the weight will strike the roll-over protection structure when the impact face of the weight and the supporting chains or wire ropes are at an angle of 20° to the vertical unless the roll-over protection structure at the point of contact has, during deflection, a greater angle to the vertical. In this case the impact face of the weight shall be adjusted by means of an additional support so that it is parallel to the roll-over protection structure at the point of impact at the moment of maximum deflection, the supporting chains or wire ropes remaining at an angle of 20° to the vertical. Steps must be taken to reduce the tendency of the weight to turn about the point of contact. The suspended height of the weight shall be so adjusted that the locus of its centre of gravity passes through the point of contact.

The point of impact shall be that part of the protection structure likely to hit the ground first if the tractor overturned sideways whilst travelling forward, normally the top front corner. The position of the centre of gravity of the weight shall be not more than 80 mm from a vertical plane parallel to the median plane of the tractor touching the outside extremity of the top of the roll-over protection structure.

However, if a curve in the front of the roll-over protection structure starts at a greater distance than 80 mm inside this vertical plane, the impact shall be administered at the beginning of the curve, i.e. at the point where this curve is tangential to a line at right angles to the median plane of the tractor (see Annex IV, fig. 9).

- 1.2.2. Tractors with rigid bodies shall be lashed down as illustrated in Annex IV, fig. 6. The points of attachment of the lashings shall be approximately 2 m behind the rear axle and 1.5 m in front of the front axle.

The lashings shall be tightened so that the deflections in the front and rear tyres are as indicated in 3.1.5 of Annex II. When the lashings have

**▼B**

been tightened, a wooden beam 150 mm square shall be clamped behind the rear wheels and driven tight against them.

- 1.2.3. Articulated tractors shall have both axles lashed down. The axle of that section of the tractor on which the roll-over protection structure is mounted shall be treated as the front axle in Annex IV, fig. 6. The point of articulation shall then be supported by a beam 100 mm square minimum and shall be lashed down firmly by means of wire ropes attached to the ground rails.
- 1.2.4. The weight shall be pulled back so that the height of its centre of gravity above that at the point of impact is given by the formula:

$$H = 125 + 0.020 W.$$

### 1.3. Impact at the side

- 1.3.1. The tractor shall be so placed in relation to the weight that the weight will strike the roll-over protection structure when the impact face of the weight and the supporting chains or wire ropes are vertical unless the protection structure at the point of contact is, during deflection, other than vertical. In this case the impact face of the weight shall be adjusted by means of an additional support so that it is parallel to the protection structure at the point of impact at the moment of maximum deflection, the supporting chains or wire ropes remaining vertical. The suspended height of the weight shall be so adjusted that the locus of its centre of gravity passes through the point of contact.

The point of impact shall be that part of the protection structure likely to hit the ground first in a sideways overturning accident, normally the upper edge. Unless it is certain that another part of this edge would hit the ground first, the point of impact shall be in the plane at right angles to the median plane of the tractor and passing through the middle of the seat at the mid-point of adjustment. Steps must be taken to reduce the tendency of the weight to turn about the point of contact. ►M3 In the case of a tractor with a reversible driving position (i.e. with a reversible seat and steering wheel), the point of impact shall be determined in relation to the intersection of the median plane of the tractor and of a plane perpendicular to it, by a straight line passing through a point that is equidistant from the two seat reference points. ◄

- 1.3.2. For rigid tractors, any axle the position of which is rigid relative to the protection structure shall be lashed down on the side on which the impact is to be administered. In the case of a two-wheel drive tractor this will normally be the rear axle; this arrangement is shown in Annex IV, fig. 7. The two lashings shall pass over the axle from points directly below it, one passing to a point of attachment approximately 1.5 m in front of the axle and the other to a point approximately 1.5 m behind the axle. The lashings shall be tightened so that there is a deflection in the tyre adjacent to the lashing as indicated in 3.1.5 of Annex II. After lashing, a wooden beam shall be placed as a prop against the wheel opposite the weight and secured to the floor so that it is held tightly against the wheel rim during impact as shown in Annex IV, fig. 7. The length of the beam shall be chosen so that when in position against the wheel it is at an angle of  $30 \pm 3^\circ$  to the horizontal. Its length shall be 20 to 25 times its thickness and its width two to three times its thickness. Both axles shall be prevented from moving sideways by means of a beam clamped to the floor against the outside of the wheel on the side opposite that on which the impact is to be administered.
- 1.3.3. An articulated tractor must be lashed down so that the section of the tractor bearing the protection structure is fixed rigidly to the ground as in the case of a non-articulated tractor.

Both axles of articulated tractors shall be lashed to the ground. The axle and wheels of that section of the tractor on which the protection structure is mounted shall be lashed and propped as in Annex IV, fig. 7. The point of articulation shall be supported by a beam at least 100 mm square and lashed down to the ground rails. A prop will be positioned against the point of articulation and secured to the floor so that it has the same effect as a prop against the rear wheel and provides support similar to that achieved for a rigid tractor.

**▼B**

- 1.3.4. The weight shall be pulled back so that the height of its centre of gravity above that at the point of impact is given by the formula:

$$H = 125 + 0.150 W.$$

**1.4. Crushing at the rear**

The tractor shall be positioned in the rig described in 2.6 of Annex II and shown in Annex IV, figs. 8 and 10 in such a way that the rear edge of the beam is over the rearmost top load-bearing part of the roll-over protection structure and the median longitudinal plane of the tractor is midway between the points of application of force to the beam.

The axle stands shall be placed under the axles in such a way that the tyres do not bear the crushing force. The force applied shall correspond to twice the mass of the tractor as defined in 1.3 of Annex II. It may be necessary to lash down the front of the tractor.

**1.5. Crushing at the front**

- 1.5.1. This test shall be identical to the crushing test at the rear except that the front edge of the beam shall be over the frontmost top part of the roll-over protection structure.
- 1.5.2. Where the front part of the roll-over protection structure roof cannot sustain the full crushing force, the force shall be applied until the roof is deflected to coincide with the plane joining the upper part of the roll-over protection structure with that part of the front of the tractor capable of supporting the tractor's mass when overturned. The force shall then be removed and the tractor re-positioned so that the beam is over that point of the roll-over protection structure which would then support the rear of the tractor when completely over-turned as shown in Annex IV, fig. 10, and the full force reapplied.

**2. ZONE OF CLEARANCE**

- 2.1. The zone of clearance is illustrated in Annex IV, fig. 3, and is defined in relation to a vertical reference plane generally longitudinal to the tractor and passing through a seat reference point, described in 2.3, and the centre of the steering wheel. The reference plane shall be assumed to move horizontally with the seat and steering wheel during impacts but to remain perpendicular to the floor of the tractor or of the roll-over protection structure if this is resiliently mounted.

Where the steering wheel is adjustable, its position should be that for normal seated driving.

- 2.2. The boundaries of the zone shall be taken as:
- 2.2.1. vertical planes 250 mm on either side of the reference plane extending upwards from the seat reference point for 300 mm;
- 2.2.2. parallel planes extending from the upper edge of planes 2.2.1 to a maximum height of 900 mm above the seat reference point and inclined in such a way that the upper edge of the plane on the side from which the side impact is struck is at least 100 mm from the reference plane;
- 2.2.3. a horizontal plane 900 mm above the seat reference point;
- 2.2.4. an inclined plane perpendicular to the reference plane and including a point 900 mm directly above the seat reference point and the rearmost point of the seat structure including its suspension;
- 2.2.5. a vertical plane perpendicular to the reference plane extending downwards from the rear-most point of the seat;
- 2.2.6. a curvilinear surface, perpendicular to the reference plane, with a radius of 120 mm tangential to planes 2.2.3 and 2.2.4;
- 2.2.7. a curvilinear surface, perpendicular to the reference plane, having a radius of 900 mm and extending forward for 400 mm from and tangential to plane 2.2.3 at a point 150 mm forward of the seat reference point;
- 2.2.8. an inclined plane perpendicular to the reference plane, joining surface 2.2.7 at its forward edge and passing 40 mm from the steering wheel. In the case of a high steering wheel position this plane is replaced by a tangent plane to surface 2.2.7;

**▼B**

- 2.2.9. a vertical plane, perpendicular to the reference plane, 40 mm forward of the steering wheel;
- 2.2.10. a horizontal plane through the seat reference point;

**▼M3**

- 2.2.11. in the case of a tractor with a reversible driving position (i.e. with a reversible seat and steering wheel), the clearance shall be a combination of the two clearances determined by the two positions of the steering wheel and seat;
- 2.2.12. in the case of a tractor which can be fitted with optional seats, the tests shall be based on the combined clearance of the seat reference points for all available seat-fitting options. The roll-over protection structure must not enter the combined clearance around the various seat reference points;
- 2.2.13. where a new option for the seat is proposed after the test has taken place, a calculation is made to determine whether the clearance around the new seat reference point is located entirely within the combined clearance established previously. If this is not the case, a new test is required.

**▼B****2.3. Seat location and seat reference point**

- 2.3.1. For the purpose of defining the zone of clearance in 2.1, the seat shall be at the rearmost point of any horizontal adjustment range. It shall be set at the mid-point of the vertical adjustment range where this is independent of adjustment of its horizontal position.

The reference point shall be established using the apparatus illustrated in Annex IV, figs. 1 and 2, to simulate loading by a human occupant. The apparatus shall consist of a seat pan board and backrest boards. The lower backrest board shall be jointed in the region of the ischium humps (A) and loin (B), the joint (B) being adjustable in height.

- 2.3.2. The reference point is defined as the point in the median longitudinal plane of the seat where the tangential plane of the lower backrest and a horizontal plane intersect. This horizontal plane cuts the lower surface of the seat pan board 150 mm in front of the abovementioned tangent.
- 2.3.3. Where a seat suspension is provided with adjustment for the weight of the driver, this shall be set so that the seat is at the mid-point of its dynamic range.

The apparatus shall be positioned on the seat. It shall then be loaded with a force of 550 N at a point 50 mm in front of joint (A), and the two parts of the backrest board shall be lightly pressed tangentially against the backrest.

- 2.3.4. If it is not possible to determine definite tangents to each area of the backrest (above and below the lumbar region) the following should be done:
  - 2.3.4.1. where no definite tangent to the lower area is possible: the lower part of the backrest board is pressed against the backrest vertically;
  - 2.3.4.2. where no definite tangent to the upper area is possible: the joint (B) is fixed at a height of 230 mm above the seat reference point, if the lower part of the backrest board is vertical. Then the two parts of the backrest board are lightly pressed against the backrest tangentially.

**3. MEASUREMENTS TO BE MADE****3.1. Fractures and cracks**

After each test all structural members, joints and attaching brackets on the tractor shall be visually examined for fractures or cracks, any small cracks in unimportant parts being ignored.

**3.2. Zone of clearance**

- 3.2.1. During each test the roll-over protection structure shall be examined to see whether any part of the roll-over protection structure has entered a zone of clearance round the driving seat as defined in 2.1 and 2.2.
- 3.2.2. In addition, the roll-over protection structure shall be examined to determine whether any part of the zone of clearance is outside the protection of the roll-over protection structure. For this purpose it shall

**▼B**

be considered to be outside the protection of the roll-over protection structure if any part of it would have come in contact with flat ground if the tractor had overturned towards the direction from which the impact came. For this purpose the tyre and track setting shall be assumed to be the smallest specified by the manufacturer.

**3.3. Maximum momentary deflection**

During the side impact test the difference between the maximum momentary deflection and the residual deflection at a height of 900 mm above and 150 mm forward of the seat reference point shall be recorded. One end of the rod described in 2.7.1 of Annex II shall be attached to the upper part of the roll-over protection structure and the other end passed through a hole in the vertical standard. The position of the friction collar on the rod after the blow indicates the maximum momentary deflection.

**3.4. Permanent deflection**

After the final compression test the permanent deflection of the protection structure shall be recorded. For this purpose, before the start of the test, the position of the main roll-over protection structure members in relation to the seat reference point shall be recorded.

▼B

ANNEX IV  
FIGURES

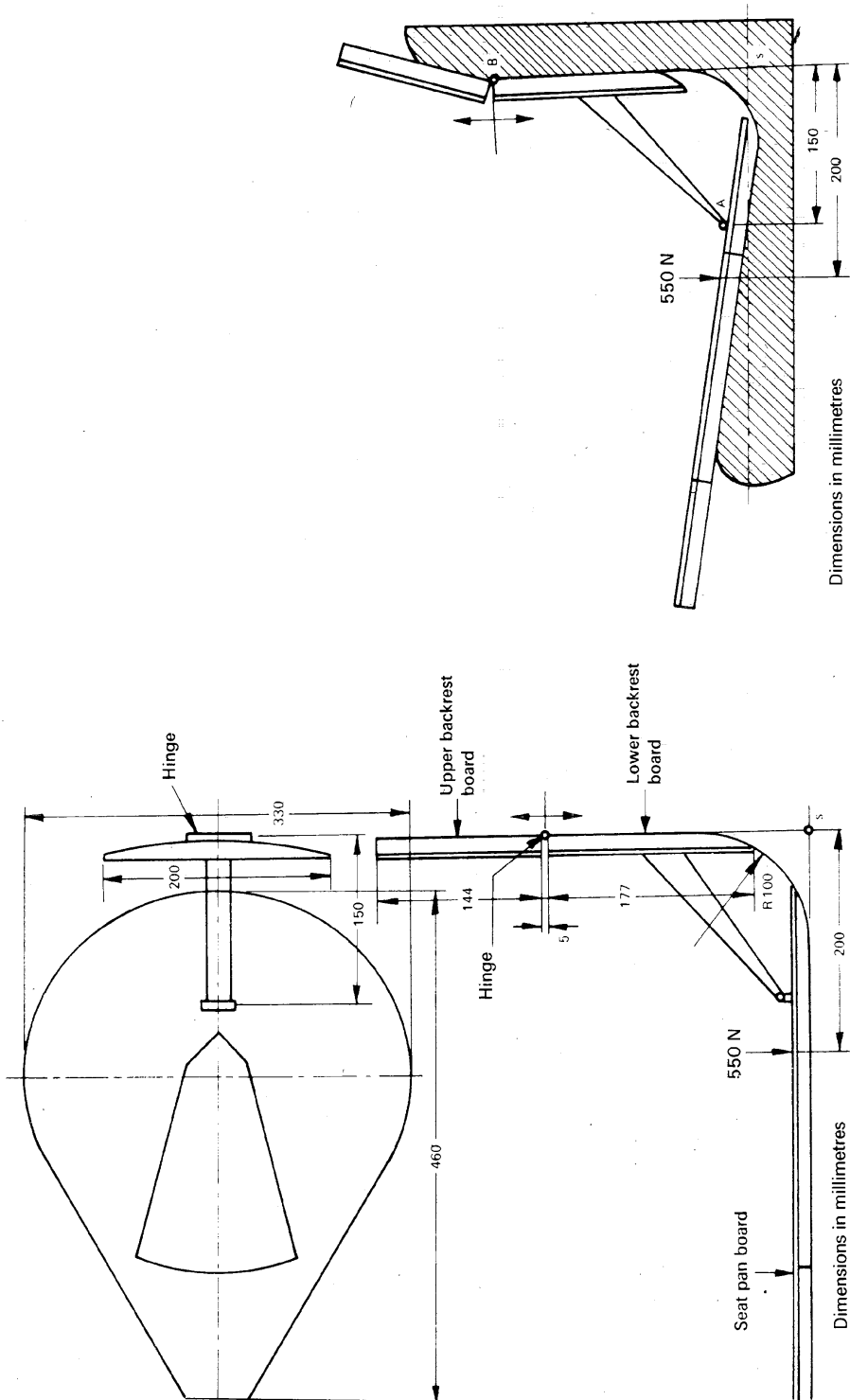

Method of determining seat reference point

Apparatus for determination of seat reference point

▼B

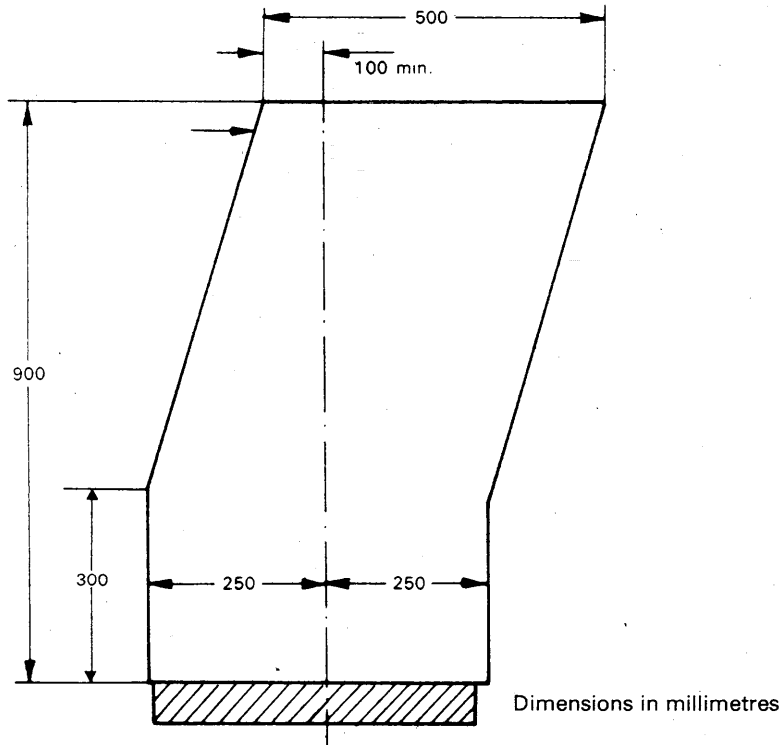
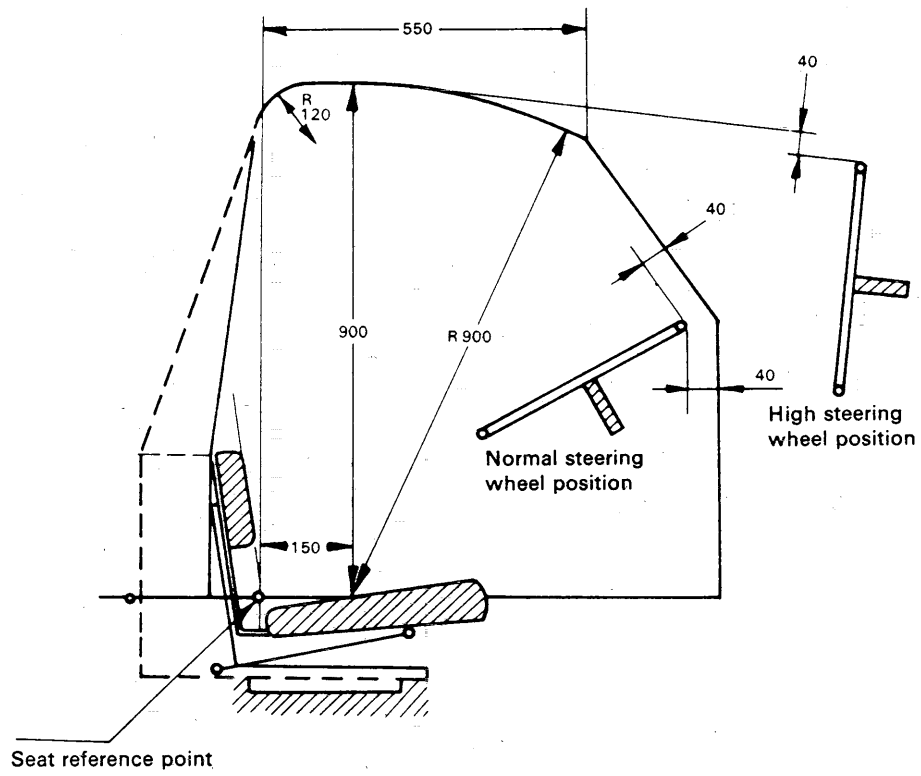

Fig. 3

Zone of clearance

▼B

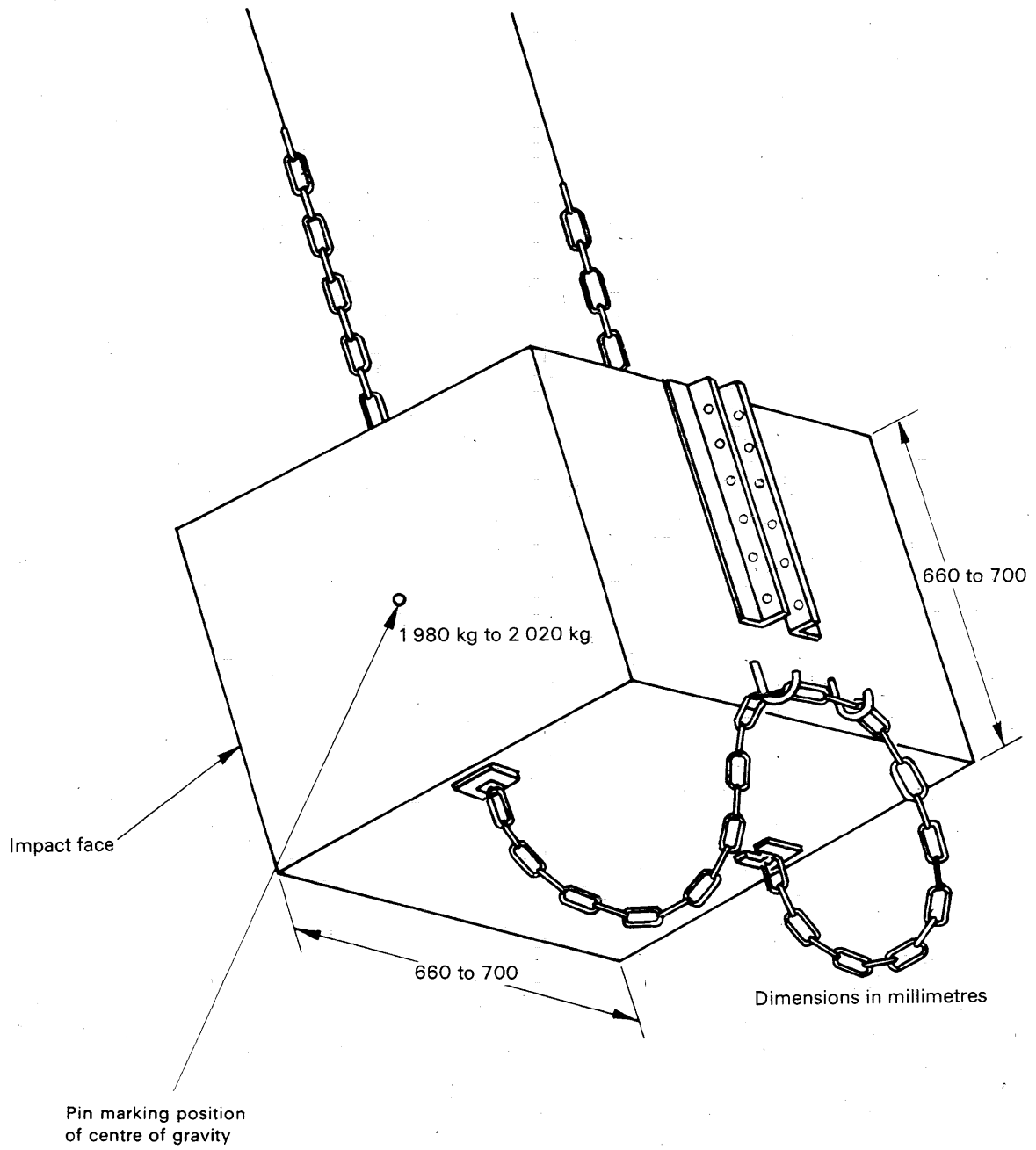

Fig. 4

Illustration of weight



**▼B**

For tyre pressures and deflections  
see 3.1.5 of Annex II

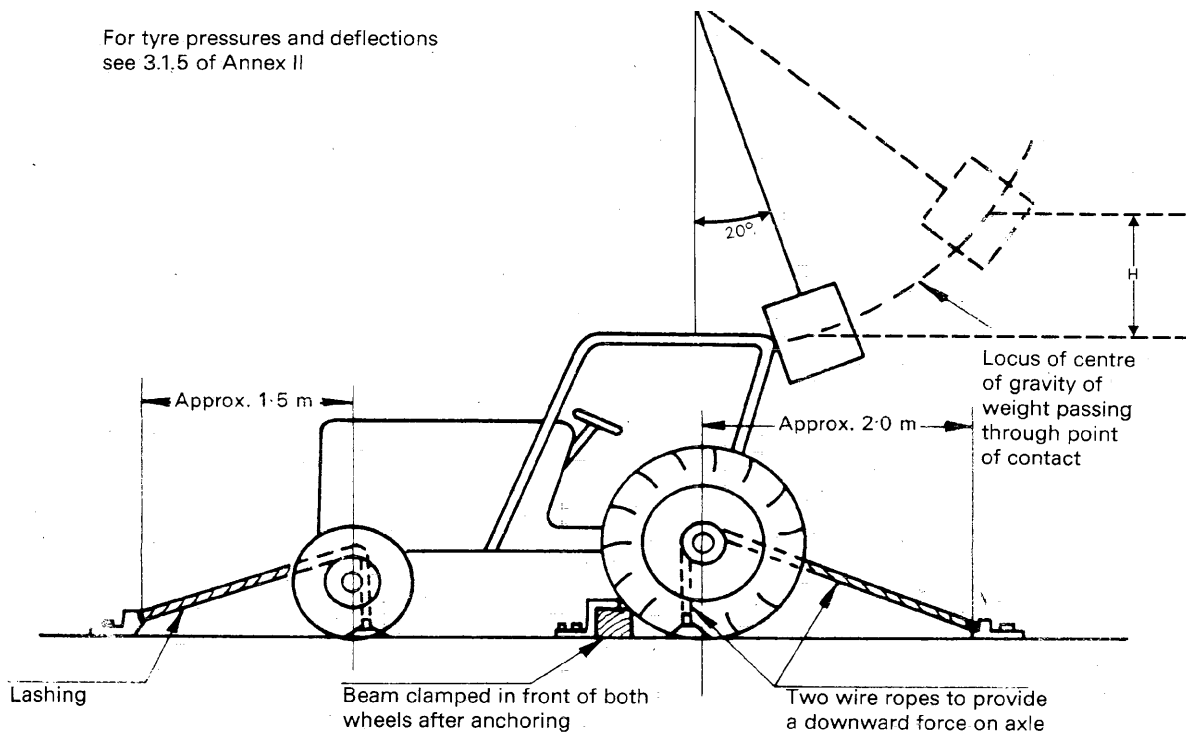

Fig. 5

**Impact from rear**

*Note:*

The configuration of the roll over protection structure shown is solely for the purpose of illustration and for dimensional reference. It does not purport to denote design requirements.

**▼B**

For tyre pressures  
and deflections  
see 3.1.5 of Annex II

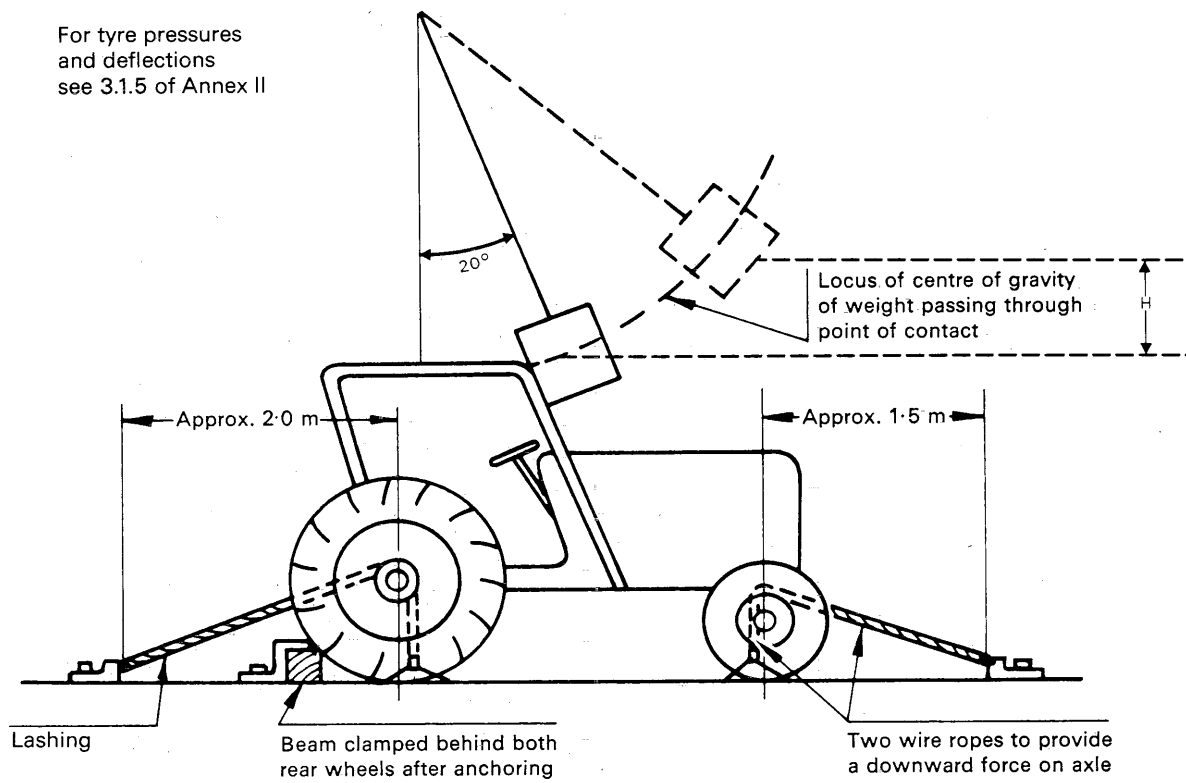

Fig. 6

**Impact from front**

*Note:*

The configuration of the roll-over protection structure shown is solely for the purpose of illustration and for dimensional reference. It does not purport to denote design requirements.

▼B

For tyre pressures and deflections  
see 3.1.5 of Annex II

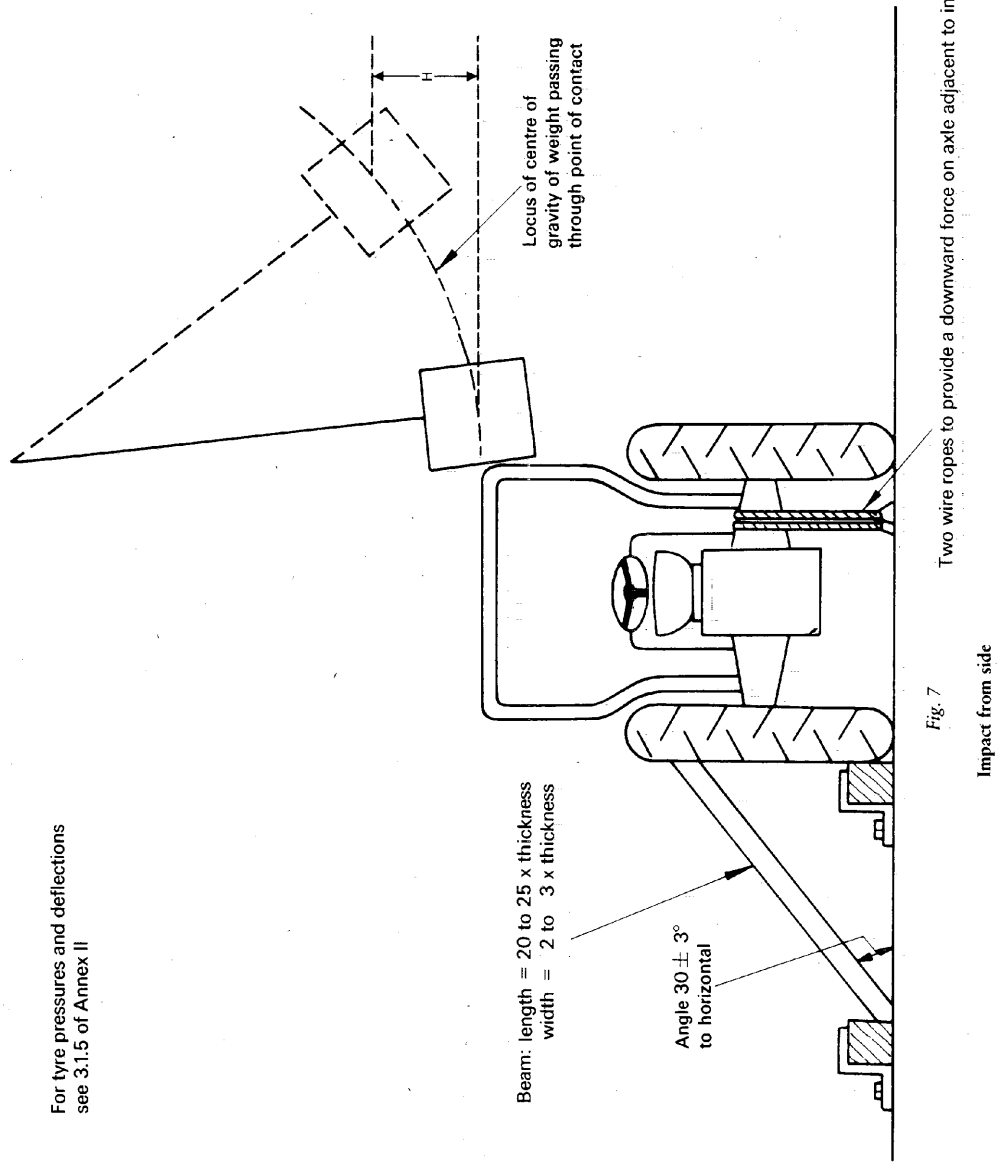

Note: The configuration of the roll-over protection structure shown is solely for the purpose of illustration and for dimensional reference. It does not purport to denote design requirements.

▼B

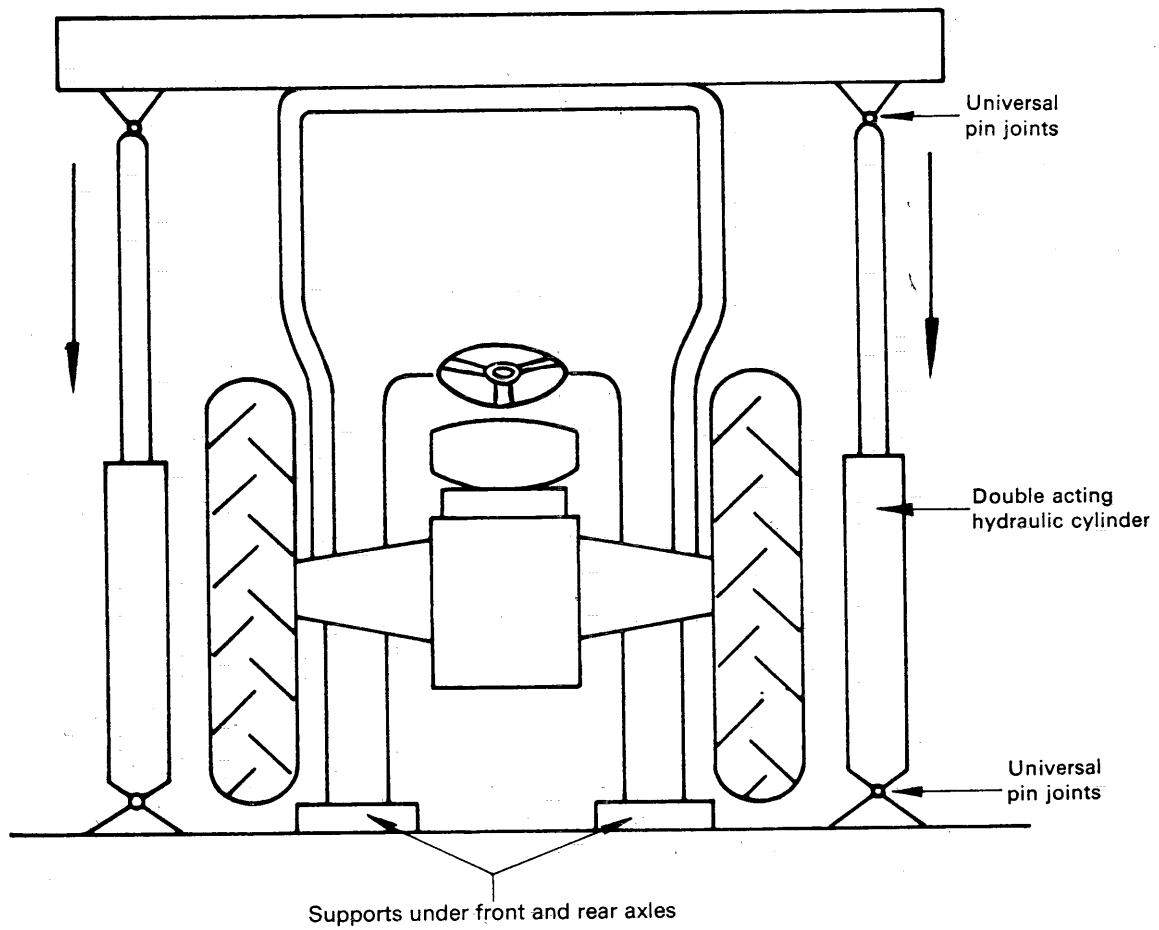

Fig. 8

**Crushing test**

*Note:*

The configuration of the roll-over protection structure shown is solely for the purpose of illustration and for dimensional reference. It does not purport to denote design requirements.

▼B

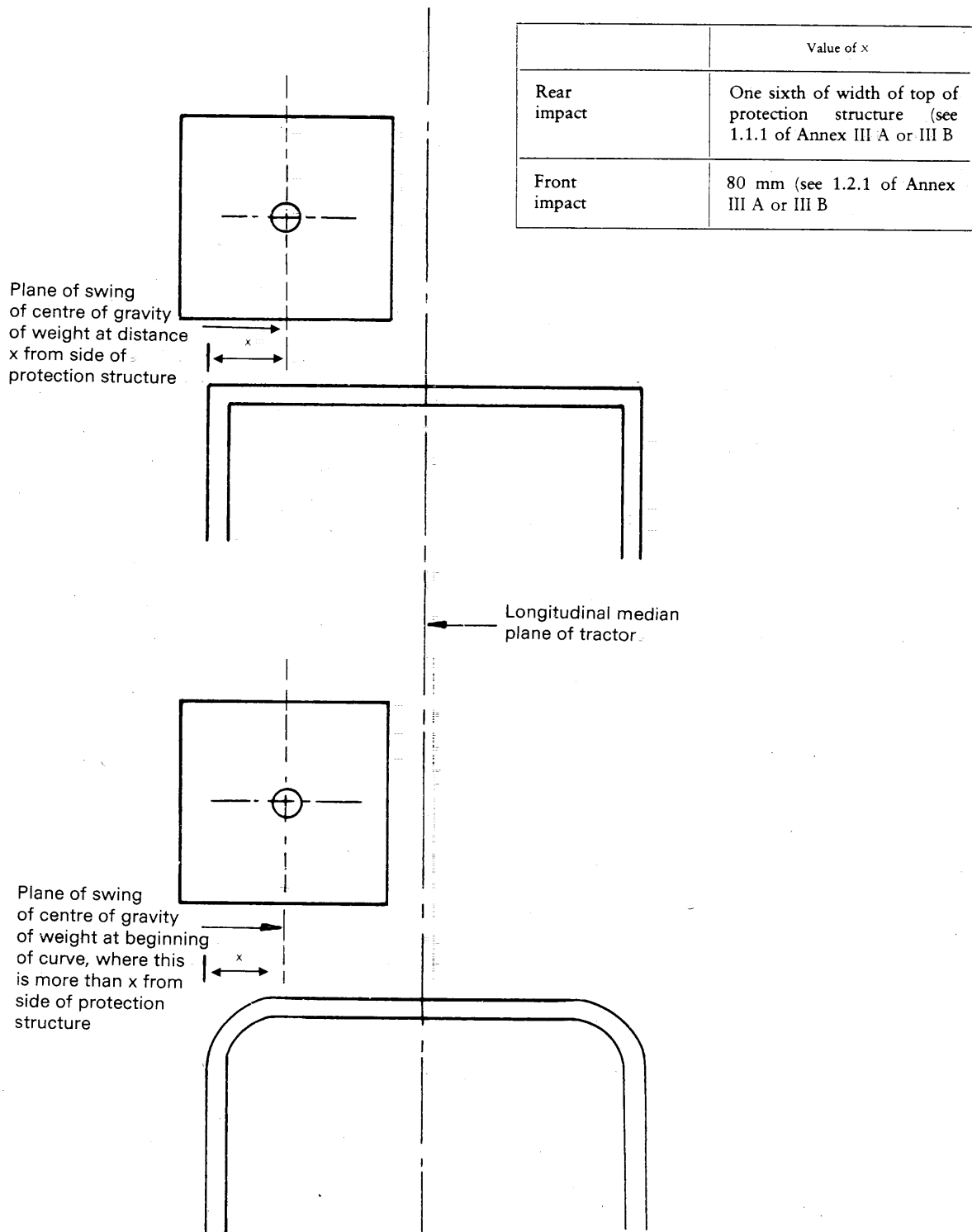

Fig. 9

Plan view of protection structure and weight showing location of plane of swing in front and rear impact tests

Note:

Weight shown on left side of median plane. For each test, the sides on which front and rear impacts are struck and determined in 3.1.4 of Annex II.

**▼B**

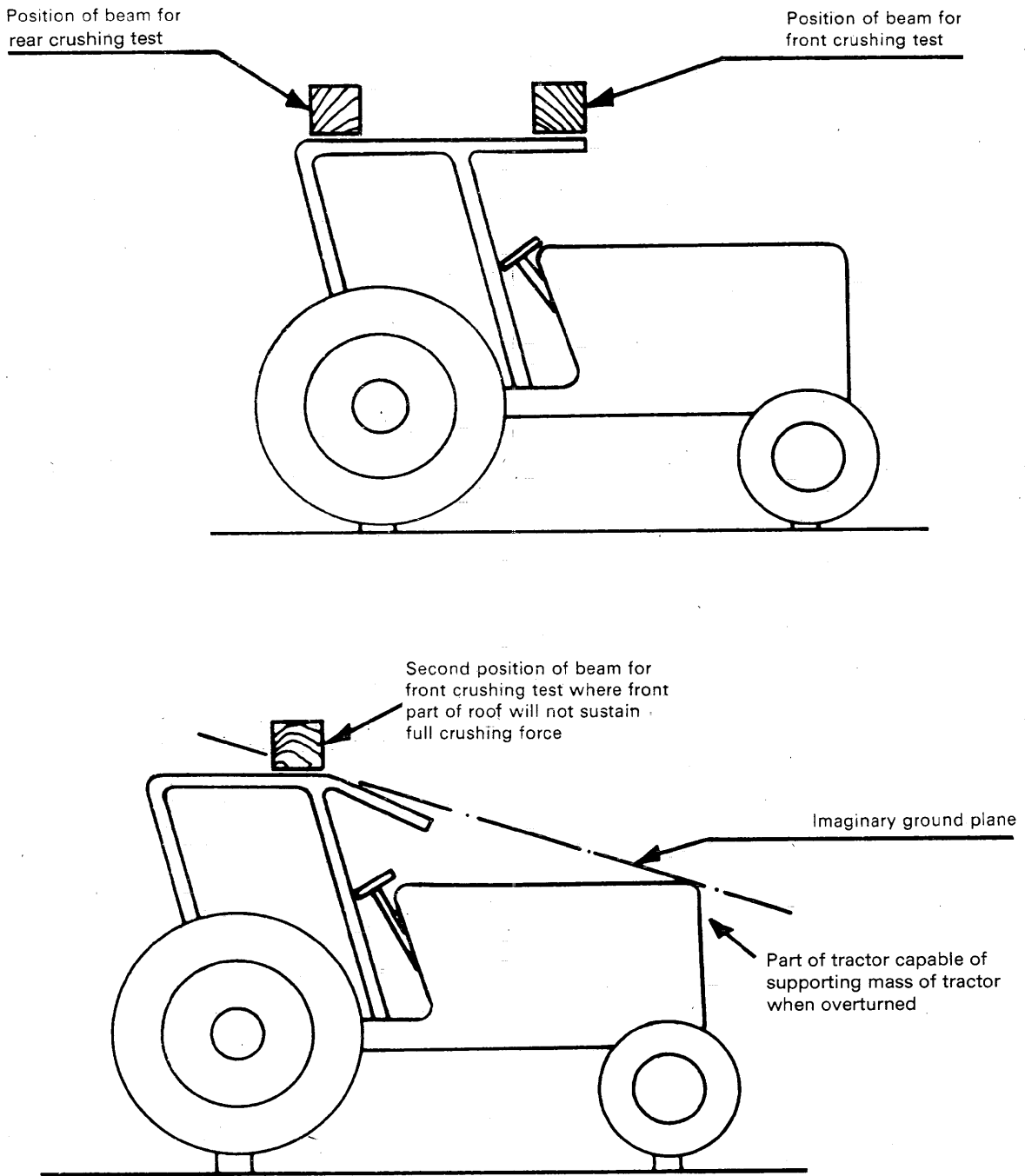

Fig. 10

Position of beam in crushing tests

*Note:*

The configuration of the roll-over protection structure shown is solely for the purpose of illustration and for dimensional reference. It does not purport to denote design requirements.

**▼B**

## ANNEX V

## MODEL

REPORT RELATING TO THE EEC COMPONENT TYPE-APPROVAL TEST OF A ROLL-OVER PROTECTION STRUCTURE (SAFETY FRAME OR CAB) WITH REGARD TO ITS STRENGTH AS WELL AS TO THE STRENGTH OF ITS ATTACHMENT TO THE TRACTOR

Protection structure	
Make	
Type	
Tractor make	
Tractor type	
Test method	I/II <sup>(1)</sup>

Identification of test station
--------------------------------

EEC component type-approval No .....

1. Trade mark or name of protection structure .....

2. Name and address of manufacturer of tractor or protection structure .....

3. If applicable, name and address of tractor or protection structure manufacturer's authorized representative .....

4. Specifications of tractor on which the tests are carried out

4.1. Trade mark or name .....

4.2. Type and commercial description .....

4.3. Serial number .....

4.4. Mass of unballasted tractor with roll-over protection structure fitted, without driver .....kg

4.5. Wheelbase/moment of inertia <sup>(1)</sup> ..... mm / kg/m<sup>2</sup> <sup>(1)</sup>4.6. Tyre sizes: front .....  
rear .....

5. Extension of EEC component type-approval for other tractor types

5.1. Trade mark or name .....

<sup>(1)</sup> Delete where inapplicable.

**▼B**

- 5.2. Type and commercial description .....
- 5.3. Mass of unballasted tractor, with roll-over protection structure fitted, without driver.....kg
- 5.4. Wheelbase/moment of inertia <sup>(1)</sup> ..... mm / kg/m<sup>2</sup> <sup>(1)</sup>
- 5.5. Tyre sizes: front .....
- rear .....
6. **Specifications of roll-over protection structure**
- 6.1. General arrangement drawing of both the roll-over protection structure and its attachment to the tractor
- 6.2. Photographs from side and rear showing mounting details
- 6.3. Brief description of roll-over protection structure including type of construction, details of mounting on the tractor, details of cladding, means of access and escape, details of interior padding, features to prevent continuous rolling and details of heating and ventilation
- 6.4. Dimensions
- 6.4.1. Height of roof members above the loaded tractor seat above the seat reference point <sup>(2)</sup> ..... mm
- 6.4.2. Height of roof members above the tractor foot platform ..... mm
- 6.4.3. Interior width of the roll-over protection structure at 950 mm above the loaded seat/at 900 mm above the seat reference point <sup>(2)</sup> ..... mm
- 6.4.4. Interior width of the roll-over protection structure at a point above the seat at the height of the centre of the steering wheel ..... mm
- 6.4.5. Distance from the centre of steering wheel to the right-hand side of roll-over protection structure ..... mm
- 6.4.6. Distance from the centre of the steering wheel to the left-hand side of roll-over protection structure ..... mm
- 6.4.7. Minimum distance from the steering wheel rim to the roll-over protection structure.....mm
- 6.4.8. Width of the doorways:
- at the top .....mm
- in the middle ..... mm
- at the bottom .....mm
- 6.4.9. Height of the doorways:
- above foot platform ..... mm

<sup>(1)</sup> Delete where inapplicable.<sup>(2)</sup> According to the test method used.



**▼B**

- above highest mounting step ..... mm
- above lowest mounting step .....mm
- 6.4.10. Overall height of the tractor with the roll-over protection structure fitted ..... mm
- 6.4.11. Overall width of the roll-over protection structure ..... mm
- 6.4.12. Horizontal distance to the rear of the protection structure from the back of the loaded seat at a height of 950 mm/from the seat reference point at a height of 900 mm <sup>(1)</sup> ..... mm
- 6.5. Details and quality of materials used, standards used .....
- Main frame .....(material and dimensions)
- Mountings ..... (material and dimensions)
- Cladding ..... (material and dimensions)
- Roof .....(material and dimensions)
- Interior padding .....(material and dimensions)
- Assembly and mounting bolts .....(grade and dimensions)
7. Test results
- 7.1. Impact and crushing tests
- Impact tests were made to the left/right-hand <sup>(2)</sup> rear and to the right/left-hand <sup>(2)</sup> front and right/left-hand side <sup>(2)</sup>. The reference mass used for calculating impact energies and crushing forces was .....kg
- The test requirements concerning fractures or cracks, maximum instantaneous deflection and the zone of clearance were satisfactorily fulfilled
- 7.2. Deflection measured after the tests
- Permanent deflection:
- rear: left-hand ..... mm
- right-hand .....mm
- front: left-hand ..... mm
- right-hand .....mm
- side sideways:
- front .....mm
- rear ..... mm
- top downwards:
- front..... mm
- rear ..... mm

<sup>(1)</sup> According to the test method used.

<sup>(2)</sup> Delete where inapplicable.

**▼B**

Difference between maximum momentary and residual deflection during sideways impact  
test ..... mm

- 8. Report number .....
- 9. Report date .....
- 10. Signature .....

**▼ B***ANNEX VI***MARKS**

The EEC component type-approval mark shall consist of a rectangle surrounding the lower-case letter 'e' followed by the distinguishing letter(s) or number of the Member State which has granted the component type-approval:

**▼ A2**

- 1 for Germany,
- 2 for France,
- 3 for Italy,
- 4 for the Netherlands,
- 6 for Belgium,
- 9 for Spain,
- 11 for the United Kingdom,
- 13 for Luxembourg,
- 18 for Denmark,

**▼ M1**

EL for Greece,

**▼ A2**

IRL for Ireland,

**▼ A3**

P for Portugal,

12 for Austria,

17 for Finland,

**▼ A4**

5 for Sweden,

8 for the Czech Republic,

29 for Estonia,

CY for Cyprus,

32 for Latvia,

36 for Lithuania,

7 for Hungary,

MT for Malta,

20 for Poland,

26 for Slovenia,

27 for Slovakia,

**▼ M4**

34 for Bulgaria,

19 for Romania.

**▼ B**

It must also include in the vicinity of the rectangle the EEC component type-approval number which corresponds to the number of the EEC component type-approval certificate issued with regard to the strength of the type of roll-over protection structure and its attachment to the tractor.

**▼B**

Example of an EEC component type-approval mark

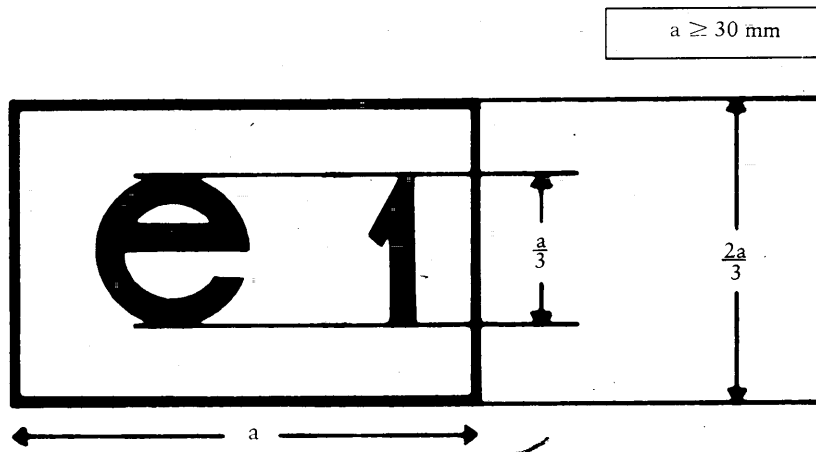

The roll-over protection structure bearing the EEC component type-approval mark shown above is a structure for which EEC component type-approval was granted in Germany (e 1) under the number 1471.

▼B

## ANNEX VII

## MODEL

## EEC COMPONENT TYPE-APPROVAL CERTIFICATE

Name of competent authority
--------------------------------

Notification concerning the granting, refusal, withdrawal or extension of EEC component type-approval with regard to the strength of a roll-over protection structure (safety cab or frame) and to the strength of its attachment to the tractor

- EEC component type-approval No ..... extension <sup>(1)</sup>
1. Trade name or mark of protection structure .....
  2. Name and address of manufacturer of protection structure .....
  3. If applicable, name and address of authorized representative of manufacturer of protection structure .....
  4. Trade mark or name, type and commercial description of tractor for which protection structure is intended .....
  5. Extension of EEC component type-approval for the following tractor type(s) .....
  - 5.1. The mass of the unballasted tractor, as defined in 1.3 of Annex II, exceeds/does not exceed <sup>(2)</sup> the reference mass used for the test by more than 5%.
  - 5.2. The method of attachment and points of attachment are/are not <sup>(2)</sup> identical.
  - 5.3. All the components likely to serve as supports for the roll-over protection structure are/are not <sup>(2)</sup> identical.
  6. Submitted for EEC component type-approval on .....
  7. Test station .....
  8. Date and number of the report of the test station .....
  9. Date of granting/refusal/withdrawal of EEC component type-approval <sup>(2)</sup> .....
  10. Date of granting/refusal/withdrawal of the extension of EEC component type-approval <sup>(2)</sup> .....
  11. Place .....
  12. Date .....
  13. The following documents, bearing the component type-approval number shown above, are annexed to this certificate (e.g. report of the test station) .....
  14. Remarks, if any .....
  15. Signature .....

<sup>(1)</sup> If applicable, state whether this is the first, second, etc. extension of the original EEC component type-approval.

<sup>(2)</sup> Delete where inapplicable.

*ANNEX VIII***CONDITIONS FOR EEC TYPE-APPROVAL**

1. The application for EEC type-approval of a tractor, with regard to the strength of a roll-over protection structure and the strength of its attachment to the tractor shall be submitted by the tractor manufacturer or by his authorized representative.
2. A tractor representative of the tractor type to be approved, on which a protection structure and its attachment, duly approved, are mounted, shall be submitted to the technical services responsible for conducting the type-approval tests.
3. The technical service responsible for conducting the type-approval tests shall check whether the approved type of protection structure is intended to be mounted on the type of tractor for which the type-approval is requested. In particular, it shall ascertain that the attachment of the protection structure corresponds to that which was tested when the EEC component type-approval was granted.
4. The holder of the EEC type-approval may ask for its extension for other types of protection structures.
5. The competent authorities shall grant such extension on the following conditions:
  - 5.1. the new type of roll-over protection structure and its tractor attachment have received EEC component type-approval;
  - 5.2. it is designed to be mounted on the type of tractor for which the extension of the EEC type-approval is requested;
  - 5.3. the attachment of the protection structure to the tractor corresponds to that which was tested when EEC component type-approval was granted.
6. A certificate, of which a model is shown in Annex IX, shall be annexed to the EEC type-approval certificate for each type-approval or type-approval extension which has been granted or refused.
7. If the application for EEC type-approval for a type of tractor is introduced at the same time as the request for EEC component type-approval for a type of roll-over protection structure intended to be mounted on the type of tractor for which EEC type-approval is requested, the checks laid down in 2 and 3 will not be made.

▼B

## ANNEX IX

## MODEL

Name of competent authority
--------------------------------

**ANNEX TO THE EEC TYPE-APPROVAL CERTIFICATE FOR A TRACTOR TYPE WITH REGARD TO THE STRENGTH OF ROLL-OVER PROTECTION STRUCTURES (SAFETY CAB OR FRAME) AND THE STRENGTH OF THEIR ATTACHMENT TO THE TRACTOR**

(Articles 4 (2) and 10 of Council Directive 74/150/EEC of 4 March 1974 on the approximation of the laws of the Member States relating to the type-approval of wheeled agricultural or forestry tractors)

- EEC type-approval No ..... extension <sup>(1)</sup> .....
1. Trade name or mark of tractor .....
  2. Tractor type .....
  3. Name and address of tractor manufacturer .....
  4. If applicable, name and address of manufacturer's authorized representative .....
  5. Trade name or mark of roll-over protection structure .....
  6. Extension of EEC type-approval for the following type(s) of protection structure .....
  7. Tractor submitted for EEC type-approval on .....
  8. Technical service responsible for EEC type-approval conformity control .....
  9. Date of report issued by that service .....
  10. Number of report issued by that service .....
  11. EEC type-approval with regard to the strength of the roll-over protection structures and the strength of their attachment to the tractor has been granted/refused <sup>(2)</sup> .....
  12. The extension of the EEC type-approval with regard to the strength of the roll-over protection structures and the strength of their attachment to tractor has been granted/refused <sup>(2)</sup> .....
  13. Place .....
  14. Date .....
  15. Signature .....

<sup>(1)</sup> If applicable, state whether this is the first, second, etc. extension of the original EEC type-approval.

<sup>(2)</sup> Delete where inapplicable.