

COUNCIL DIRECTIVE

of 28 June 1977

on the approximation of the laws of the Member States relating to reversing lamps for motor vehicles and their trailers

(77/539/EEC)

THE COUNCIL OF THE EUROPEAN COMMUNITIES,

Having regard to the Treaty establishing the European Economic Community, and in particular Article 100 thereof,

Having regard to the proposal from the Commission,

Having regard to the opinion of the European Parliament ⁽¹⁾,

Having regard to the opinion of the Economic and Social Committee ⁽²⁾,

Whereas the technical requirements which motor vehicles must satisfy pursuant to national laws relate *inter alia* to their reversing lamps;

Whereas these requirements differ from one Member State to another; whereas it is therefore necessary that all Member States adopt the same requirements either in addition to or in place of their existing rules, in order, in particular, to allow the EEC type-approval procedure which was the subject of Council Directive 70/156/EEC of 6 February 1970 on the approximation of the laws of the Member States relating to the type-approval of motor vehicles and their trailers ⁽³⁾, to be introduced in respect of each type of vehicle;

Whereas in Directive 76/756/EEC ⁽⁴⁾, the Council laid down the common requirements for the installation of lighting and light-signalling devices on motor vehicles and their trailers;

Whereas a harmonized component type-approval procedure for reversing lamps makes it possible for each Member State to check compliance with the common

construction and testing requirements and to inform the other Member States of its findings by sending a copy of the component type-approval certificate completed for each type of reversing lamp; whereas the placing of an EEC component type-approval mark on all reversing lamps manufactured in conformity with the approved type obviates any need for technical checks on these reversing lamps in the other Member States;

Whereas it is desirable to take into account the technical requirements adopted by the UN Economic Commission for Europe in its Regulation No 23 ('Uniform provisions concerning the approval of reversing lights for power-driven vehicles and their trailers') ⁽⁵⁾ which is annexed to the Agreement of 20 March 1958 concerning the adoption of uniform conditions for approval and reciprocal recognition of approval for motor vehicle equipment and parts;

Whereas the approximation of national laws relating to motor vehicles entails reciprocal recognition by Member States of the tests carried out by each of them on the basis of the common requirements,

HAS ADOPTED THIS DIRECTIVE:

Article 1

1. Each Member State shall grant EEC component type-approval for any type of reversing lamp which satisfies the construction and testing requirements laid down in Annexes 0, II, III and IV.

2. The Member State which has granted EEC component type-approval shall take the measures required in order to verify that production models conform to the approved type, in so far as this is necessary and if need be in cooperation with the competent authorities in the other Member States. Such verification shall be limited to spot checks.

⁽¹⁾ OJ No C 118, 16. 5. 1977, p. 29.

⁽²⁾ OJ No C 114, 11. 5. 1977, p. 3.

⁽³⁾ OJ No L 42, 23. 2. 1970, p. 1.

⁽⁴⁾ OJ No L 262, 27. 9. 1976, p. 1.

⁽⁵⁾ Economic Commission for Europe document E/ECE/324/E/ECE/TRANS/505/Rev. 1/Add 22, 20. 8. 1971.

Article 2

Member States shall for each type of reversing lamp which they approve pursuant to Article 1, issue to the manufacturer, or to his authorized representative, an EEC component type-approval mark conforming to the model shown in Annex II.

Member States shall take all appropriate measures to prevent the use of marks liable to create confusion between reversing lamps which have been type-approved pursuant to Article 1, and other devices.

Article 3

1. No Member State may prohibit the placing on the market of reversing lamps on grounds relating to their construction or method of functioning if they bear the EEC component type-approval mark.

2. Nevertheless, a Member State may prohibit the placing on the market of reversing lamps bearing the EEC component type-approval mark which consistently fail to conform to the approved type.

That State shall inform the other Member States and the Commission forthwith of the measures taken, specifying the reasons for its decision.

Article 4

The competent authorities of each Member State shall within one month send to the competent authorities of the other Member States a copy of the component type-approval certificates, an example of which is given in Annex I, completed for each type of reversing lamp which they approve or refuse to approve.

Article 5

1. If the Member State which has granted EEC component type-approval finds that a number of reversing lamps bearing the same EEC component type-approval mark do not conform to the type which it has approved, it shall take the necessary measures to ensure that production models conform to the approved type. The competent authorities of that State shall advise those of the other Member States of the measures taken which may, where there is consistent failure to conform, extend to withdrawal of EEC component type-approval. The said authorities shall take the same measures if they are informed by the competent authorities of another Member State of such failure to conform.

2. The competent authorities of Member States shall inform each other within one month of any withdrawal of EEC component type-approval, and of the reasons for such a measure.

Article 6

Any decision taken pursuant to the provisions adopted in implementation of this Directive, to refuse or withdraw EEC component type-approval for a reversing lamp or prohibit its placing on the market or use shall set out in detail the reasons on which it is based. Such decisions shall be notified to the party concerned, who shall at the same time be informed of the remedies available to him under the laws in force in the Member States and of the time limits allowed for the exercise of such remedies.

Article 7

No Member State may refuse to grant EEC type-approval or national type-approval of any vehicle on grounds relating to its reversing lamps if these bear the EEC component type-approval mark and are fitted in accordance with the requirements laid down in Directive 76/756/EEC.

Article 8

No Member State may refuse or prohibit the sale, registration, entry into service or use of any vehicle on grounds relating to its reversing lamps if these bear the EEC component type-approval mark and are fitted in accordance with the requirements laid down in Directive 76/756/EEC.

Article 9

For the purposes of this Directive, 'vehicle' means any motor vehicle intended for use on the road, with or without bodywork, having at least four wheels and a maximum design speed exceeding 25 km/h, and its trailers, with the exception of vehicles which run on rails, agricultural or forestry tractors and machinery and public works vehicles.

Article 10

Any amendments necessary to adjust the requirements of the Annexes to take account of technical progress shall be adopted in accordance with the procedure laid down in Article 13 of Directive 70/156/EEC.

Article 11

1. Member States shall bring into force the provisions needed in order to comply with this Directive within 18

months of its notification and shall forthwith inform the Commission thereof.

2. Member States shall ensure that the texts of the main provisions of national law which they adopt in the field covered by this Directive are communicated to the Commission.

Article 12

This Directive is addressed to the Member States.

Done at Luxembourg, 28 June 1977.

For the Council

The President

W. RODGERS

LIST OF ANNEXES

- ANNEX 0 ⁽¹⁾: Definitions, general specifications, intensity of light emitted, test procedure, colour of light emitted, conformity of production
- ANNEX I: Model EEC component type-approval certificate
- ANNEX II: EEC component type-approval and marking requirements
- ANNEX III ⁽¹⁾: Photometric measurements
- ANNEX IV ⁽¹⁾: Colour of light emitted, trichromatic coordinates

⁽¹⁾ The technical requirements of this Annex are similar to those of Regulation No 23 of the Economic Commission for Europe. In particular, the breakdown into sections is the same. For this reason, where a section in Regulation No 23 has no counterpart in this Directive, its number is given in brackets for the record.

ANNEX 0

DEFINITIONS, GENERAL SPECIFICATIONS, INTENSITY OF LIGHT EMITTED, TEST PROCEDURE, COLOUR OF LIGHT EMITTED, CONFORMITY OF PRODUCTION

1. DEFINITIONS

- 1.1. '*Reversing lamp*' means the lamp used to illuminate the road to the rear of the vehicle and to warn other road-users that the vehicle is reversing or about to reverse.
- 1.2. '*Axis of reference*' means the characteristic axis of the light signal, determined by the manufacturer for use as the direction of reference ($H = 0^\circ$, $V = 0^\circ$) for photometric measurements and when fitting the lamp on the vehicle.
- 1.3. '*Centre of reference*' means the intersection of the axis of reference with the exterior light-emitting surface. It is specified by the manufacturer of the lamp.
- 1.4. '*Type of reversing lamp*' means reversing lamps which do not differ in such essential respects as:
 - 1.4.1. the trade name or mark;
 - 1.4.2. the characteristics of the optical system;
 - 1.4.3. the inclusion of components capable of altering the optical effects by reflection, refraction or absorption;
 - 1.4.4. the type of filament lamp.
- (2.)
- (3.)
- (4.)

5. GENERAL SPECIFICATIONS

- 5.1. Each of the samples referred to in 1.2.3 of Annex II shall conform to the specifications set forth in the sections below.
- 5.2. The reversing lamps shall be so designed and constructed that under normal conditions of use, notwithstanding any vibration to which they may be subjected during such use, their satisfactory operation remains assured and they retain the characteristics prescribed by this Directive.

6. INTENSITY OF LIGHT EMITTED

- 6.1. The light emitted by each of the two samples referred to in 1.2.3 of Annex II shall be of not less than the minimum intensity and of not more than the maximum intensity specified below and shall be measured in relation to the axis of reference in the directions shown below (expressed in degrees from the axis of reference).
- 6.2. The intensity along the axis of reference shall be not less than 80 cd.
- 6.3. The intensity of the light emitted in all directions in which the lamp can be observed shall not exceed:
 - 300 cd in directions in or above the horizontal plane;
 - 600 cd in directions below the horizontal plane.
- 6.4. In every other direction of measurement shown in Annex III, the luminous intensity shall be of not less than the minima specified in that Annex.

7. TEST PROCEDURE

All measurements shall be carried out with a colourless standard filament lamp of the type recommended for the reversing lamp and so regulated as to produce the normal luminous flux prescribed for this type of lamp.

8. COLOUR OF LIGHT EMITTED

The colour of the light emitted must be white. In case of doubt, the colour may be checked on the basis of the definition of the colour of white light given in Annex IV.

9. CONFORMITY OF PRODUCTION

Every reversing lamp bearing an EEC component type-approval mark must conform to the type approved and comply with the photometric conditions specified in 6 and 8. Nevertheless, in the case of a reversing lamp picked at random from series production, the requirements as to minimum intensity of the light emitted (measured with a standard filament lamp as referred to in 7) may be limited in each relevant direction 80% of the minimum value specified in 6.

(10.)

(11.)

ANNEX I

MODEL EEC COMPONENT TYPE-APPROVAL CERTIFICATE

(Maximum format: A4 (210 x 297 mm))

Name of administration

Notification concerning the granting, refusal or withdrawal of EEC component type-approval for a type of reversing lamp

- EEC component type-approval No
- 1. Type of reversing lamp
- 2. Type(s) of filament lamp(s)
- 3. Trade name or mark of the reversing lamp
- 4. Name and address of manufacturer
- 5. If applicable, name and address of manufacturer's authorized representative
- 6. Submitted for EEC component type-approval on
- 7. Technical service conducting EEC component type-approval tests
- 8. Date of report issued by that service
- 9. Number of report issued by that service
- 10. Date of granting/refusal/withdrawal of EEC component type-approval ⁽¹⁾
- 11. Single EEC component type-approval granted on the basis of 3.3 of Annex II for a lighting and light-signalling device comprising several lamps, and in particular:
- 12. Date of granting/refusal/withdrawal of single EEC component type-approval ⁽¹⁾
- 13. Place
- 14. Date
- 15. Signature
- 16. The attached drawing No shows the geometrical position in which the reversing lamp is to be mounted on the vehicle, and the axis of reference and centre of reference of the reversing lamp.
- 17. Remarks

⁽¹⁾ Delete where inapplicable.

ANNEX II

EEC COMPONENT TYPE-APPROVAL AND MARKING REQUIREMENTS

1. APPLICATION FOR EEC COMPONENT TYPE-APPROVAL
 - 1.1. The application for EEC component type-approval shall be submitted by the holder of the trade name or mark or by his authorized representative.
 - 1.2. For each type of reversing lamp, the application shall be accompanied by:
 - 1.2.1. a brief technical description stating, in particular, the type(s) of filament lamp(s) recommended, which must comply with the specifications of the International Commission on Illumination (CIE)
 - 1.2.2. drawings (three copies), in sufficient detail to permit identification of the type of the reversing lamp and showing geometrically the position in which the reversing lamp is to be mounted on the vehicle, the axis of observation to be taken as the axis of reference in the tests (horizontal angle $H = 0^\circ$, vertical angle $V = 0^\circ$), and the point to be taken as the centre of reference in the said tests;
 - 1.2.3. two samples.
2. MARKINGS
 - 2.1. The samples of a type of reversing lamp submitted for EEC component type-approval must bear:
 - 2.1.1. the trade name or mark of the applicant, which must be clearly legible and indelible;
 - 2.1.2. a clearly legible and indelible marking indicating the type(s) of filament lamp(s) recommended;
 - 2.1.3. if necessary, in order to prevent any mistake in mounting the reversing lamp on the vehicle, the word 'TOP' marked horizontally on the uppermost part of the lens;
 - 2.1.4. and incorporate a space large enough to contain the EEC component type-approval mark, including the additional symbols prescribed in 4; this space shall be shown in the drawings mentioned in 1.2.2.
3. EEC COMPONENT TYPE-APPROVAL
 - 3.1. If the two samples submitted in accordance with 1 meet the requirements of Annexes 0, II, III and IV, EEC component type-approval shall be granted and a component type-approval number assigned.
 - 3.2. This number shall not be assigned to any other type of reversing lamp.
 - 3.3. Where EEC component type-approval is requested for a type of lighting and light-signalling device comprising a reversing lamp and other lamps, a single EEC component type-approval mark may be issued provided that the reversing lamp complies with the requirements of this Directive and that each of the other lamps forming part of the lighting and light-signalling device for which EEC component type-approval is requested, complies with the specific Directive applying to it.
4. MARKS
 - 4.1. Every reversing lamp conforming to a type approved under this Directive shall bear an EEC component type-approval mark.

- 4.2. This mark shall consist of a rectangle surrounding the lower-case letter 'e', followed by the distinguishing number or letter(s) of the Member State which has granted the component type-approval:
- 1 for Germany,
 - 2 for France,
 - 3 for Italy,
 - 4 for the Netherlands,
 - 6 for Belgium,
 - 11 for the United Kingdom,
 - 13 for Luxembourg,
 - 18 for Denmark,
 - IRL for Ireland.
- It must also include the EEC component type-approval number, which corresponds to the number of the EEC component type-approval certificate issued for the type of reversing lamp in question.
- 4.3. The EEC component type-approval mark shall be supplemented by an additional symbol 'AR'.
- 4.4. The EEC component type-approval number must be placed in any convenient position near the rectangle surrounding the letter 'e'.
- 4.5. The EEC component type-approval mark and the additional symbol must be affixed to the lens of the lamp, or one of the lenses, in such a way as to be indelible and clearly legible even when the reversing lamp is fitted on the vehicle.
- 4.6. An example of the EEC component type-approval mark and the above additional symbol combining the letters A and R, is shown in the Appendix.
- 4.7. Where a single EEC component type-approval number is issued, as under 3.3, for a type of lighting and light-signalling device comprising a reversing lamp and other lamps, one EEC component type-approval mark only may be affixed, consisting of:
- a rectangle surrounding the letter 'e', followed by the distinguishing number or letter(s) of the Member State which has granted the EEC component type-approval,
 - an EEC component type-approval number,
 - the additional symbols required by the various Directives under which EEC component type-approval was granted.
- 4.8. The dimensions of the various components of this mark shall not be less than the largest of the minimum dimensions specified for individual markings by the Directives under which the EEC component type-approval was granted.
-

Appendix

Example of an EEC component type-approval mark

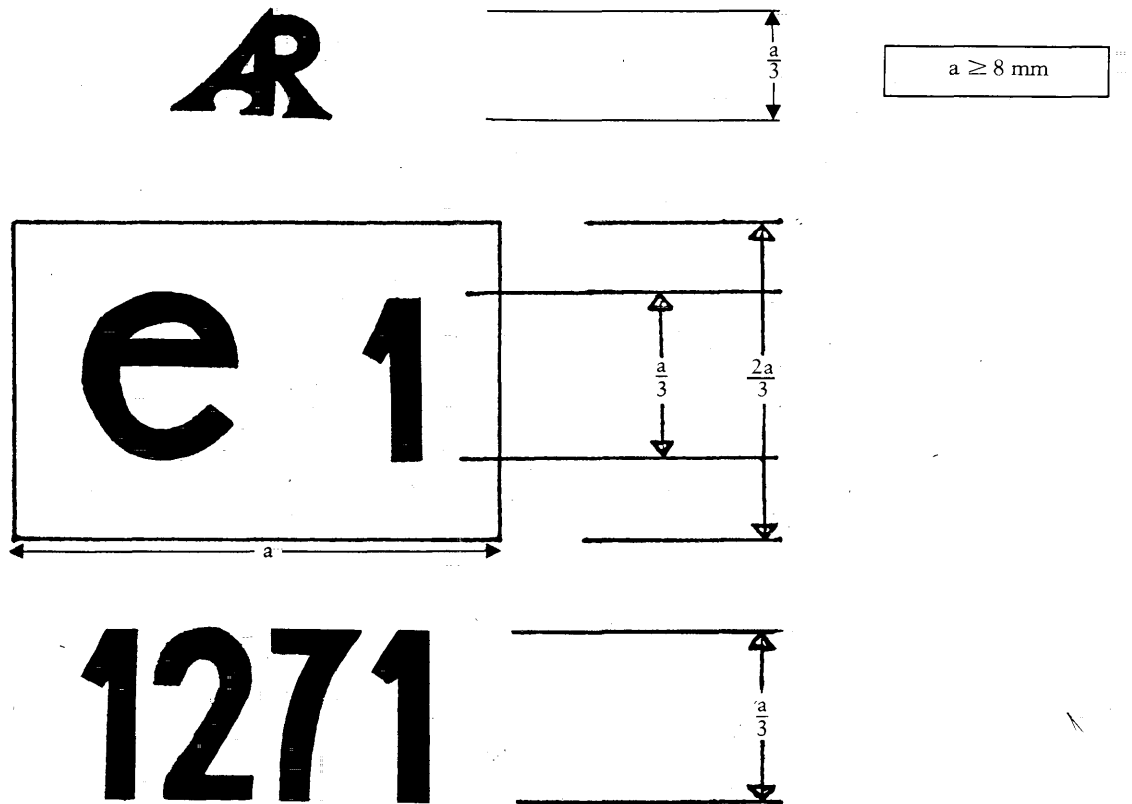

The device bearing the EEC component type-approval mark shown above is a reversing lamp EEC type-approved in Germany (e 1) under the number 1271.

ANNEX III

PHOTOMETRIC MEASUREMENTS

1. MEASUREMENT METHODS

- 1.1. During photometric measurements, stray reflections shall be prevented by appropriate masking.
- 1.2. Should the results of measurements be challenged, measurements shall be carried out in such a way as to meet the following requirements:
- 1.2.1. the distance of measurement shall be such that the law of the inverse of the square of the distance is applicable;
- 1.2.2. the measuring equipment shall be such that the angular aperture of the receiver viewed from the reference centre of the lamp is between $10'$ and 1° ;
- 1.2.3. the intensity requirement for a particular direction of observation shall be satisfied if that requirement is met in a direction deviating by not more than $15'$ from the direction of observation.

2. MEASURING POINTS EXPRESSED IN DEGREES OF ANGLE WITH THE AXIS OF REFERENCE AND VALUES OF THE MINIMUM INTENSITIES OF THE LIGHT EMITTED

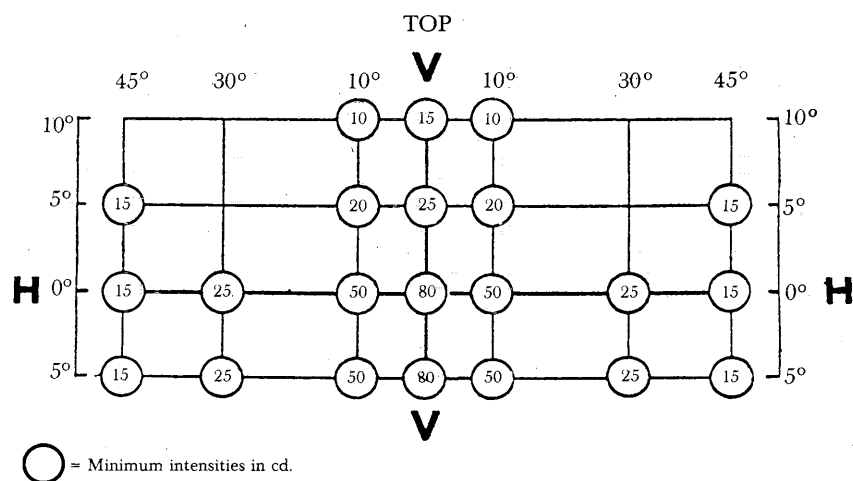

- 2.1. The direction $H = 0^\circ$ and $V = 0^\circ$ corresponds to the axis of reference (which, when the lamp is mounted on the vehicle, must be horizontal, parallel to the median longitudinal plane of the vehicle and oriented in the required direction of visibility). It passes through the centre of reference. The values shown in the table give, for the various directions of measurement, the minimum intensities in cd.
- 2.2. If visual examination of a lamp appears to reveal substantial local variations of intensity, a check shall be made to ensure that no intensity measured between two of the directions of measurement referred to above is below 50% of the lower minimum intensity of the two prescribed for these directions of measurement.

ANNEX IV

COLOUR OF LIGHT EMITTED

TRICHROMATIC COORDINATES

WHITE:	{	limit towards blue:	$x \leq 0.310$
		limit towards yellow:	$x \leq 0.500$
		limit towards green:	$y \leq 0.150 + 0.640 x$
		limit towards green:	$y \leq 0.440$
		limit towards purple:	$y \leq 0.050 + 0.750 x$
		limit towards red:	$y \leq 0.382$

For checking these colorimetric characteristics, a source of light at a colour temperature of 2 854 K corresponding to illuminant A of the International Commission on Illumination (CIE) shall be used.