

Council Directive of 28 June 1977 on the approximation of  
the laws of the Member States relating to safety belts and  
restraint systems of motor vehicles (77/541/EEC) (repealed)

COUNCIL DIRECTIVE

of 28 June 1977

on the approximation of the laws of the Member States  
relating to safety belts and restraint systems of motor vehicles

(77/541/EEC) (repealed)

THE COUNCIL OF THE EUROPEAN COMMUNITIES,

Having regard to the Treaty establishing the European Economic Community and in particular Article 100 thereof,

Having regard to the proposal from the Commission,

Having regard to the opinion of the European Parliament<sup>(1)</sup>,

Having regard to the opinion of the Economic and Social Committee<sup>(2)</sup>,

Whereas the technical requirements which motor vehicles must satisfy pursuant to national laws relate *inter alia* to seat belts and restraint systems;

Whereas these requirements differ from one Member State to another; whereas it is therefore necessary that all Member States adopt the same requirements either in addition to or in place of their existing regulations, in order in particular to allow the EEC type-approval procedure which was the subject of Council Directive 70/156/EEC of 6 February 1970 on the approximation of the laws of the Member States relating to the type-approval of motor vehicles and their trailers<sup>(3)</sup> to be applied in respect of each type of vehicle;

Whereas common requirements for the interior parts of the passenger compartment, the layout of controls, the roof, the backrest and rear part of the seats have been laid down by Directive 74/60/EEC<sup>(4)</sup>; whereas requirements for the internal fittings relating to the protection of the driver against injury by the steering mechanism in the event of an impact have been laid down by Directive 74/297/EEC<sup>(5)</sup>; whereas requirements relating to the strength of the seats and their anchorages have been laid down by Directive 74/408/EEC<sup>(6)</sup>; whereas requirements relating to anchorages for safety belts have been laid down by Directive 76/115/EEC<sup>(7)</sup>; whereas other requirements relating to internal fittings, and in particular those relating to head restraints and the identification of the controls, will be laid down at a later date;

Whereas rules for seat belts and restraint systems include not only design requirements but also their fitting in motor vehicles;

Whereas a harmonized component type-approval procedure for safety belts and restraint systems makes it possible for each Member State to check compliance with the common design and testing requirements and to inform the other Member States of its findings by sending a copy

---

*Status: EU Directives are being published on this site to aid cross referencing from UK legislation. After IP completion day (31 December 2020 11pm) no further amendments will be applied to this version.*

---

of the component type-approval certificate completed for each type of safety belt or restraint system; whereas the placing of an EEC component type-approval mark on all safety belts and restraint systems manufactured in conformity with the approved type obviates any need for technical checks on these safety belts and restraint systems in the other Member States;

Whereas the main purpose of the harmonized requirements is to promote road safety; whereas it should therefore be made compulsory to fit safety belts and restraint systems to vehicles covered by this Directive;

Whereas the approximation of national laws relating to motor vehicles entails mutual recognition by the Member States of checks carried out by each of them on the basis of the common requirements,

HAS ADOPTED THIS DIRECTIVE:

#### *Article 1*

1 Each Member State shall grant EEC component type-approval for any type of three-point or lap safety belt and any type of restraint system which satisfies the design and test requirements laid down in 2 of Annex I and in Annexes IV to XIV.

2 The Member State which has granted EEC component type-approval shall take the measures required to ensure that production models conform to the approved type, if need be in cooperation with the competent authorities in the other Member States.

3 For the purpose of implementing paragraph 2, it shall be sufficient for a Member State to ensure that as a minimum the quality-control procedures laid down in 2.8.1 of Annex I are applied.

If, however, the checks are made by the Member State itself, or by laboratories authorized by it, the methods used shall be such as to give results at least as reliable as those that would be given by the procedures provided for in paragraph 1. The procedure laid down in 2.8.2 of Annex I is, in particular, an appropriate method.

#### *Article 2*

Member States shall, for each type of safety belt or restraint system which they approve pursuant to Article 1, issue to the manufacturer<sup>F1</sup>, or to his authorized representative,] an EEC component type-approval mark conforming to one of the models shown in Annex III.

Member States shall take all appropriate measures to prevent the use of marks liable to create confusion between safety belts or restraint systems which have been type-approved pursuant to Article 1 and other devices.

#### **Textual Amendments**

- F1** Deleted by [Commission Directive 96/36/EC of 17 June 1996 adapting to technical progress Council Directive 77/541/EEC relating to safety belts and restraint systems of motor vehicles \(Text with EEA relevance\)](#).

---

*Status: EU Directives are being published on this site to aid cross referencing from UK legislation. After IP completion day (31 December 2020 11pm) no further amendments will be applied to this version.*

---

### Article 3

1 No Member State may prohibit the placing on the market of safety belts and restraint systems on grounds relating to their design or method of functioning if they bear the EEC component type-approval mark.

2 Nevertheless, a Member State may prohibit the placing on the market of safety belts and restraint systems bearing the EEC component type-approval mark which consistently fail to conform to the approved type.

That State shall inform the other Member States and the Commission forthwith of the measures taken, specifying the reasons for its decision.

### <sup>F2</sup> Article 4

The competent authorities of the Member States shall inform each other, by means of the procedure specified in Article 4 (6) of Directive 70/156/EEC, of each type of safety belt and restraint systems for which an approval has been granted, refused or withdrawn.]

#### Textual Amendments

- F2** Substituted by [Commission Directive 96/36/EC of 17 June 1996 adapting to technical progress Council Directive 77/541/EEC relating to safety belts and restraint systems of motor vehicles \(Text with EEA relevance\)](#).

### Article 5

1 If a Member State which has granted EEC component type-approval finds that a number of safety belts and restraint systems bearing the same EEC component type-approval mark do not conform to the type which it has approved, it shall take the necessary measures to ensure that production models conform to the approved type. The competent authorities of that State shall advise those of the other Member States of the measures taken, which may, where there is consistent failure to conform, extend to withdrawal of EEC component type-approval. The said authorities shall take the same measures if they are informed by the competent authorities of another Member State of such failure to conform.

2 The competent authorities of the Member States shall inform one another within one month of any withdrawal of EEC component type-approval and of the reasons for such measure.

3 If a Member State which has granted EEC component type-approval disputes the failure to conform notified to it, the Member States concerned shall endeavour to settle the dispute. The Commission shall be kept informed and shall, where necessary, hold appropriate consultations for the purpose of reaching a settlement.

### Article 6

Any decision taken pursuant to the provisions adopted in implementation of this Directive to refuse or withdraw EEC component type-approval for safety belts or restraint systems or prohibit their placing on the market or use shall set out in detail the reasons on which it is based. Such decisions shall be notified to the party concerned, who shall at the same time be informed of the remedies available to him under the laws in force in the Member States and of the time limits allowed for the exercise of such remedies.

---

*Status: EU Directives are being published on this site to aid cross referencing from UK legislation. After IP completion day (31 December 2020 11pm) no further amendments will be applied to this version.*

---

### Article 7

No Member State may refuse to grant EEC type-approval or national type-approval for a vehicle on grounds relating to the safety belts or restraint systems with which it is equipped, if these bear the EEC component type-approval mark and are fitted in accordance with the requirements laid down in 3 of Annex I.

### Article 8

No Member State may refuse or prohibit the sale, registration, entry into service or use of any vehicle on grounds relating to its safety belts or restraint systems, if these bear the EEC component type-approval mark and are fitted in accordance with the requirements laid down in 3 of Annex I.

### <sup>F3</sup>Article 9

For the purposes of this Directive, ‘vehicle’ means any motor vehicle in categories M and N as defined in [<sup>F2</sup>Annex II A] to Directive 70/156/EEC intended for use on the road, having at least four wheels and a maximum design speed exceeding 25 km/h.]

#### Textual Amendments

- F2** Substituted by [Commission Directive 96/36/EC of 17 June 1996 adapting to technical progress Council Directive 77/541/EEC relating to safety belts and restraint systems of motor vehicles \(Text with EEA relevance\)](#).
- F3** Substituted by [Council Directive of 20 July 1981 amending Council Directive 77/541/EEC on the approximation of the laws of the Member States relating to safety belts and restraint systems of motor vehicles \(81/576/EEC\)](#).

### Article 10

The amendments necessary for adapting the Annexes to take account of technical progress shall be adopted in accordance with the procedure laid down in Article 13 of Directive 70/156/EEC.

### Article 11

1 Member States shall bring into force the provisions necessary in order to comply with this Directive within 18 months of its notification and shall forthwith inform the Commission thereof.

2 Member States shall ensure that the texts of the main provisions of national law which they adopt in the field covered by this Directive are communicated to the Commission.

### Article 12

This Directive is addressed to the Member States.

*Status: EU Directives are being published on this site to aid cross referencing from UK legislation. After IP completion day (31 December 2020 11pm) no further amendments will be applied to this version.*

## [<sup>F4</sup>ANNEX I

### SCOPE, DEFINITIONS, EC COMPONENT TYPE- APPROVAL, INSTALLATION REQUIREMENTS

#### Textual Amendments

- F4** Substituted by [Commission Directive 2000/3/EC of 22 February 2000](#) adapting to technical progress [Council Directive 77/541/EEC](#) relating to safety belts and restraint systems of motor vehicles (Text with EEA relevance).

0.	<b>SCOPE</b> This Directive applies to safety belts and restraint systems which are designed for installation in vehicles conforming to the definition given in Annex II to Directive 70/156/EEC and are intended for separate use, i.e. as individual fittings, by persons of adult build occupying forward or rearward-facing seats and to child restraint systems designated for installation in vehicles of category M1, N1.
1.	<b>DEFINITIONS</b> For the purposes of this Directive:
1.1.	‘safety belt (seat belt, belt)’ means an assembly of straps with a securing buckle, adjusting devices and attachments which is capable of being anchored to a power-driven vehicle and is designed to diminish the risk of injury to its wearer, in the event of collision or of abrupt vehicle deceleration, by limiting the mobility of the wearer's body. Such an assembly is generally referred to as a ‘belt assembly’, a term also embracing any device for energy absorption or belt retraction;
1.1.1.	‘lap belt’ means a belt which passes across the front of the wearer's pelvic region;
<b>a</b>	Vehicle categories defined in Annex IIA to Directive 70/156/EEC.
<b>b</b>	<a href="#">OJ L 38, 11.2.1974, p. 2.</a>
<b>c</b>	<a href="#">OJ L 24, 30.1.1976, p. 6.</a>
<b>d</b>	<a href="#">OJ L 24, 30.1.1976, p. 6.</a>
<b>e</b>	<a href="#">OJ L 165, 20.6.1976, p. 16.</a>
<b>f</b>	In addition to the requirements of 3.1, Member States may, under national law, accept other types of safety belts or restraint systems covered by this Directive for certain vehicle types.
<b>g</b>	<a href="#">OJ L 221, 12.8.1974, p. 1.</a>

---

*Status: EU Directives are being published on this site to aid cross referencing from UK legislation. After IP completion day (31 December 2020 11pm) no further amendments will be applied to this version.*

---

1.1.2.	‘diagonal belt’ means a belt which passes diagonally across the front of the chest, from the hip to the opposite shoulder;
1.1.3.	‘three-point belt’ means a belt which is essentially a combination of a lap strap and a diagonal strap;
1.1.4.	‘harness belt’ means a belt assembly comprising a lap belt and shoulder straps;
1.2.	‘belt type’ means a category of belts which do not differ in such essential respects as:
1.2.1.	rigid parts (buckle, attachments, retractor, etc.);
1.2.2.	the material, weave, dimensions and colour of the straps;
1.2.3.	the geometry of the belt assembly;
1.3.	‘strap’ means a flexible component designed to hold the body and to transmit stresses to the belt anchorages;
1.4.	‘buckle’ means a quick-release device enabling the wearer to be held by the belt. The buckle may incorporate the belt adjusting device, except in the case of a harness belt buckle;
1.5.	‘belt-adjusting device’ means a device enabling the belt to be adjusted according to the requirements of the individual wearer and to the position of the seat. The adjusting device may be part of the buckle, the retractor or any other part of the safety belt;
1.6.	‘attachments’ means parts of the belt assembly, including the necessary securing components, which enable it to be attached to the belt anchorages;
1.7.	‘energy absorber’ means a device designed to disperse energy independently of, or jointly with, the strap and forming part of a belt assembly;
<b>a</b>	Vehicle categories defined in Annex IIA to Directive 70/156/EEC.
<b>b</b>	OJ L 38, 11.2.1974, p. 2.
<b>c</b>	OJ L 24, 30.1.1976, p. 6.
<b>d</b>	OJ L 24, 30.1.1976, p. 6.
<b>e</b>	OJ L 165, 20.6.1976, p. 16.
<b>f</b>	In addition to the requirements of 3.1, Member States may, under national law, accept other types of safety belts or restraint systems covered by this Directive for certain vehicle types.
<b>g</b>	OJ L 221, 12.8.1974, p. 1.

*Status: EU Directives are being published on this site to aid cross referencing from UK legislation. After IP completion day (31 December 2020 11pm) no further amendments will be applied to this version.*

1.8.	‘retractor’ means a device for accommodating a part or the whole of the strap of a safety belt;
1.8.1.	‘non-locking retractor (type 1)’ means a retractor from which the strap is extracted to its full length by a small external force and which allows no adjustment of the strap which has been extracted;
1.8.2.	‘manually unlocking retractor (type 2)’ means a retractor requiring the manual operation of a device by the user to unlock the retractor in order to obtain the desired strap extraction and which locks automatically when the said operation ceases;
1.8.3.	‘automatically locking retractor (type 3)’ means a retractor allowing extraction of the strap to the desired length and which, when the buckle is fastened, automatically adjusts the strap to the wearer. Further extraction of the strap is not possible without deliberate action on the part of the wearer;
1.8.4.	‘emergency locking retractor (type 4)’ means a retractor which, in normal driving conditions, does not restrict the freedom of movement of the wearer of the safety belt. It has a length adjusting device which automatically adjusts the strap to the wearer, and a locking mechanism actuated in an emergency by:
1.8.4.1.	deceleration of the vehicle (single sensitivity);
1.8.4.2.	a combination of the deceleration of the vehicle, movement of the webbing or any other automatic means (multiple sensitivity);
1.8.5.	‘emergency-locking retractor with higher response threshold (type 4N)’ means a retractor of the type defined in point 1.8.4, but having special properties as regards use
<b>a</b>	Vehicle categories defined in Annex IIA to Directive 70/156/EEC.
<b>b</b>	<a href="#">OJ L 38, 11.2.1974, p. 2.</a>
<b>c</b>	<a href="#">OJ L 24, 30.1.1976, p. 6.</a>
<b>d</b>	<a href="#">OJ L 24, 30.1.1976, p. 6.</a>
<b>e</b>	<a href="#">OJ L 165, 20.6.1976, p. 16.</a>
<b>f</b>	In addition to the requirements of 3.1, Member States may, under national law, accept other types of safety belts or restraint systems covered by this Directive for certain vehicle types.
<b>g</b>	<a href="#">OJ L 221, 12.8.1974, p. 1.</a>

---

*Status: EU Directives are being published on this site to aid cross referencing from UK legislation. After IP completion day (31 December 2020 11pm) no further amendments will be applied to this version.*

---

	in vehicles of categories M2, M3, N1, N2 and N3 <sup>a</sup> ;
1.8.6.	‘belt adjustment device for height’ means a device enabling the position in height of the upper loop of a belt to be adjusted according to the requirements of the individual wearer and the position of the seat. Such a device may be considered as a part of the belt or a part of the anchorage of the belt;
1.9.	‘belt anchorages’ means the parts of the vehicle structure or seat structure or any other part of the vehicle to which the safety belts are to be secured;
1.10.	‘vehicle type’ as regards safety belts and restraint systems means a category of power-driven vehicles which do not differ in such essential respects as the dimensions, lines and constituent materials of the components of the vehicle structure or seat structure or any other part of the vehicle to which the safety belts and the restraint systems are attached;
1.11.	‘restraint system’ means a system combining a seat, fixed to the structure of the vehicle by appropriate means, and a safety belt for which at least one anchorage is located on the seat structure;
1.12.	‘seat’ means a structure which may or may not be integral with the vehicle structure complete with trim, intended to seat one adult person. The term covers both an individual seat and part of a bench seat intended to seat one person;
1.12.1.	a ‘front passenger seat’ means any seat where the ‘foremost H-point’ of the seat in question is in or in front of the vertical transverse plane through the driver's R-point;
1.13.	‘group of seats’ means either a bench-type seat, or seats which are separate but side-
<b>a</b>	Vehicle categories defined in Annex IIA to Directive 70/156/EEC.
<b>b</b>	<a href="#">OJ L 38, 11.2.1974, p. 2.</a>
<b>c</b>	<a href="#">OJ L 24, 30.1.1976, p. 6.</a>
<b>d</b>	<a href="#">OJ L 24, 30.1.1976, p. 6.</a>
<b>e</b>	<a href="#">OJ L 165, 20.6.1976, p. 16.</a>
<b>f</b>	In addition to the requirements of 3.1, Member States may, under national law, accept other types of safety belts or restraint systems covered by this Directive for certain vehicle types.
<b>g</b>	<a href="#">OJ L 221, 12.8.1974, p. 1.</a>



*Status: EU Directives are being published on this site to aid cross referencing from UK legislation. After IP completion day (31 December 2020 11pm) no further amendments will be applied to this version.*

	by-side (i.e. fixed so that the front seat anchorages of one of these seats are in line with the front or rear anchorages of the other or between the anchorages of the other seat) and seat one or more adults;
1.14.	‘bench seat’ means a structure complete with trim, intended to seat at least two adults;
1.15.	‘adjustment system’ means the device by which the seat or its parts can be adjusted to a position suited to the morphology of the seated occupant. This device may, in particular, allow:
1.15.1.	longitudinal displacement;
1.15.2.	vertical displacement;
1.15.3.	angular displacement;
1.16.	‘seat anchorage’ means the system by which the seat assembly is secured to the vehicle structure, including the affected parts of the vehicle structure;
1.17.	‘seat type’ means a category of seats which do not differ in such essential respects as:
1.17.1.	the structure, shape, dimensions and materials of the seat;
1.17.2.	the type and dimensions of the adjustment systems and all locking systems;
1.17.3.	the type and dimensions of the belt anchorages on the seat, of the seat anchorage and of the affected parts of the vehicle structure;
1.18.	‘displacement system’ means a device enabling the seat or one of its parts to be displaced angularly or longitudinally, without a fixed intermediate position, to facilitate passenger access;

**a** Vehicle categories defined in Annex IIA to Directive 70/156/EEC.

**b** OJ L 38, 11.2.1974, p. 2.

**c** OJ L 24, 30.1.1976, p. 6.

**d** OJ L 24, 30.1.1976, p. 6.

**e** OJ L 165, 20.6.1976, p. 16.

**f** In addition to the requirements of 3.1, Member States may, under national law, accept other types of safety belts or restraint systems covered by this Directive for certain vehicle types.

**g** OJ L 221, 12.8.1974, p. 1.

---

*Status: EU Directives are being published on this site to aid cross referencing from UK legislation. After IP completion day (31 December 2020 11pm) no further amendments will be applied to this version.*

---

1.19.	‘locking system’ means a device ensuring that the seat and its parts are maintained in any position of use;
1.20.	‘recessed buckle-release button’: it must not be possible to release the buckle using a sphere having a diameter of 40 mm;
1.21.	‘non-recessed buckle-release button’: it must be possible to release the buckle using a sphere having a diameter of 40 mm;
1.22.	‘preloading device’ means an additional or integrated device which tightens the strap in order to reduce the slack of the belt during a crash sequence;
1.23.	‘reference zone’ means the space between two vertical longitudinal planes, 400 mm apart and symmetrical with respect to the H-point, and defined by rotation of the apparatus, described in Annex II to Council Directive 74/60/EEC <sup>b</sup> , from vertical to horizontal. The apparatus shall be positioned as described in that Annex and set to the maximum length of 840 mm;
1.24.	‘airbag assembly’ means a device installed to supplement safety belts and restraint systems in power-driven vehicles, i.e. systems which, in the event of a severe impact affecting the vehicle automatically deploy a flexible structure intended to limit, by compression of the gas contained within it, the gravity of the contacts of one or more parts of the body of an occupant of the vehicle with the interior of the passenger compartment;
1.25.	‘passenger airbag’ means an airbag assembly intended to protect occupant(s) in seats other than the driver's in the event of a frontal collision;
1.26.	‘child restraint’ means an arrangement of components which may comprise a combination of straps or flexible

**a** Vehicle categories defined in Annex IIA to Directive 70/156/EEC.

**b** OJ L 38, 11.2.1974, p. 2.

**c** OJ L 24, 30.1.1976, p. 6.

**d** OJ L 24, 30.1.1976, p. 6.

**e** OJ L 165, 20.6.1976, p. 16.

**f** In addition to the requirements of 3.1, Member States may, under national law, accept other types of safety belts or restraint systems covered by this Directive for certain vehicle types.

**g** OJ L 221, 12.8.1974, p. 1.

---

---

*Status: EU Directives are being published on this site to aid cross referencing from UK legislation. After IP completion day (31 December 2020 11pm) no further amendments will be applied to this version.*

---

	components with a securing buckle, adjusting devices, attachments, and in some cases a supplementary chair and/or an impact shield, capable of being anchored to a power-driven vehicle. It is also so designed as to diminish the risk of injury to the wearer, in the event of a collision or of abrupt deceleration of the vehicle, by limiting the mobility of the wearer's body;
1.27.	‘rearward-facing’ means facing in the direction opposite to the normal direction of travel of the vehicle.
2.	EC COMPONENT TYPE-APPROVAL
2.1.	Application for EC component type-approval.
2.1.1.	The application for EC component type-approval pursuant to Article 3(4) of Directive 70/156/EEC of a type of safety belt shall be submitted by the manufacturer. The application for EC component type-approval pursuant to Article 3(4) of Directive 70/156/EEC of a type of restraint system shall be submitted by the manufacturer or by the manufacturer of the vehicle in which it is to be installed.
2.1.2.	A model for the information document is given in Appendix 1 to Annex II.
2.1.3.	The following samples must be submitted to the technical service conducting the type-approval tests.
2.1.3.1.	Six samples of which one for reference purposes.
2.1.3.2.	A 10-metre length of each type of strap used in the type of belt.
2.1.3.3.	The technical service conducting the component type-approval tests shall be entitled to request further samples.
<b>a</b>	Vehicle categories defined in Annex IIA to Directive 70/156/EEC.
<b>b</b>	<a href="#">OJ L 38, 11.2.1974, p. 2.</a>
<b>c</b>	<a href="#">OJ L 24, 30.1.1976, p. 6.</a>
<b>d</b>	<a href="#">OJ L 24, 30.1.1976, p. 6.</a>
<b>e</b>	<a href="#">OJ L 165, 20.6.1976, p. 16.</a>
<b>f</b>	In addition to the requirements of 3.1, Member States may, under national law, accept other types of safety belts or restraint systems covered by this Directive for certain vehicle types.
<b>g</b>	<a href="#">OJ L 221, 12.8.1974, p. 1.</a>

---

*Status: EU Directives are being published on this site to aid cross referencing from UK legislation. After IP completion day (31 December 2020 11pm) no further amendments will be applied to this version.*

---

2.1.4.	In the case of restraint systems, two samples shall be submitted by the applicant to the technical service conducting approval tests for the restraint system. These may include two of the samples of belts mentioned in 2.1.2.1 and, at the manufacturer's choice, either a vehicle representative of the vehicle type to be approved, or the part or parts of the vehicle considered essential by the service.
2.1.5.	In the case of child restraint systems four samples shall be supplied:
2.1.5.1.	a 10-metre length of each category of strap used in the child restraint, except the crotch strap of which two metres shall be supplied; and
2.1.5.2.	instructions and details of packaging in accordance with paragraph 14 of Annex XVII.
2.1.5.3.	The technical service conducting the component type-approval tests shall be entitled to request further samples.
2.1.5.4.	In the case of carry-cots, if the carry-cot restraint may be used in combination with a number of types of carry-cots, the restraint manufacturer shall supply a list of the latter.
2.1.5.5.	Where an approved adult safety belt is used to secure the child restraint, the application must stipulate the category of adult safety belt to be used, e.g. static lap belts.
2.1.6.	The competent authority shall verify the existence of satisfactory arrangements for ensuring effective control of conformity of production before type-approval is granted.
2.2.	Markings.
2.2.1.	The samples of a belt type or type of restraint system submitted for EC component type-approval in accordance with 2.1.3 or 2.1.4
<b>a</b>	Vehicle categories defined in Annex IIA to Directive 70/156/EEC.
<b>b</b>	<a href="#">OJ L 38, 11.2.1974, p. 2.</a>
<b>c</b>	<a href="#">OJ L 24, 30.1.1976, p. 6.</a>
<b>d</b>	<a href="#">OJ L 24, 30.1.1976, p. 6.</a>
<b>e</b>	<a href="#">OJ L 165, 20.6.1976, p. 16.</a>
<b>f</b>	In addition to the requirements of 3.1, Member States may, under national law, accept other types of safety belts or restraint systems covered by this Directive for certain vehicle types.
<b>g</b>	<a href="#">OJ L 221, 12.8.1974, p. 1.</a>

*Status: EU Directives are being published on this site to aid cross referencing from UK legislation. After IP completion day (31 December 2020 11pm) no further amendments will be applied to this version.*

	shall be clearly and indelibly marked with the manufacturer's name, trade name or mark.
2.2.2.	The samples of child restraint submitted for approval in accordance with points 2.1.5 and 2.1.5.1 shall be clearly and indelibly marked with the manufacturer's name, initials or trade mark.
2.2.2.1.	One of the parts made of plastics of the child restraint device (such as shell, impact shield, booster cushion, etc.), except the belt(s) or harness shall be marked clearly (and indelibly) with the year of production.
2.2.2.2.	If the restraint is to be used in combination with an adult safety belt the correct routing of the webbing shall be clearly indicated by means of a drawing permanently attached to the restraint. If the restraint is held in place by the adult safety-belt the routes of the webbing for forward and rear-facing modes shall be clearly distinguished on the product by colour coding. The colours for the safety-belt route to be used when the device is installed forward facing shall be red and when installed rearfacing shall be blue. The same colours shall also be used on the labels on the device that illustrates the methods of use. The separate routes of the lap and shoulder sections of the safety-belt shall each be distinguished on the product by colour coding and/or words. The marking defined above shall be visible with the restraint in the vehicle. For Group 0 restraints, this marking shall also be visible with the child in the restraint.
2.2.2.3.	Rearward-facing child restraints shall have a permanently attached label, visible in the installed position, with the warning:
<b>a</b>	Vehicle categories defined in Annex IIA to Directive 70/156/EEC.
<b>b</b>	OJ L 38, 11.2.1974, p. 2.
<b>c</b>	OJ L 24, 30.1.1976, p. 6.
<b>d</b>	OJ L 24, 30.1.1976, p. 6.
<b>e</b>	OJ L 165, 20.6.1976, p. 16.
<b>f</b>	In addition to the requirements of 3.1, Member States may, under national law, accept other types of safety belts or restraint systems covered by this Directive for certain vehicle types.
<b>g</b>	OJ L 221, 12.8.1974, p. 1.

*Status: EU Directives are being published on this site to aid cross referencing from UK legislation. After IP completion day (31 December 2020 11pm) no further amendments will be applied to this version.*

	<div style="border: 1px solid black; padding: 10px; text-align: center;"> <p><b>EXTREME HAZARD</b></p> <p><b>Do not use in passenger seats equipped with airbags</b></p> </div> <p>this label shall be provided in the language of the country where the device is sold.</p>
2.2.2.4.	<p>In the case of restraints that can be used forward and rear-facing, include the words:</p> <div style="border: 1px solid black; padding: 10px; text-align: center;"> <p><b>IMPORTANT</b></p> <p><b>DO NOT USE FORWARD FACING BEFORE THE CHILD'S WEIGHT EXCEEDS ...</b></p> </div> <p><b>(Refer to instructions)</b></p>
2.3.	General specifications.
2.3.1.	Each sample submitted in accordance with 2.1 shall conform to the specifications set out in 2.3 to 2.7.
2.3.2.	In the case of child restraint systems each sample submitted in accordance with 2.1 shall conform to the relevant requirements contained in Annex XVII.
2.3.3.	The belt or the restraint system shall be so designed and constructed that when correctly installed and properly used by an occupant, it
a	Vehicle categories defined in Annex IIA to Directive 70/156/EEC.
b	OJ L 38, 11.2.1974, p. 2.
c	OJ L 24, 30.1.1976, p. 6.
d	OJ L 24, 30.1.1976, p. 6.
e	OJ L 165, 20.6.1976, p. 16.
f	In addition to the requirements of 3.1, Member States may, under national law, accept other types of safety belts or restraint systems covered by this Directive for certain vehicle types.
g	OJ L 221, 12.8.1974, p. 1.

---

**Status:** EU Directives are being published on this site to aid cross referencing from UK legislation. After IP completion day (31 December 2020 11pm) no further amendments will be applied to this version.

---

	operates satisfactorily and reduces the risk of bodily injury in the event of an accident.
2.4.	Rigid parts.
2.4.1.	General.
2.4.1.1.	The rigid parts of the safety belt, such as buckles, adjusting devices, attachments and the like, shall not have sharp edges liable to cause wear or breakage of the straps by chafing.
2.4.1.2.	All parts of a belt assembly liable to be affected by corrosion shall be suitably protected against it. After undergoing the corrosion test prescribed in 2.7.2, neither signs of deterioration likely to impair the proper functioning of the device nor any significant corrosion shall be visible to the unaided eye of a qualified observer.
2.4.1.3.	Rigid parts intended to absorb energy or to be subjected to or to transmit a load shall not be fragile.
2.4.1.4.	The rigid items and parts made of plastic of a safety belt must be so located and installed that when a power-driven vehicle is in normal use, they cannot become trapped under a sliding seat or in a door of the vehicle. If one of the parts does not meet the above requirements, it must be subjected to the cold impact test specified in 2.7.6.4. After test, if any visible cracks are present in the plastic covers or retainers of rigid items, these parts made of plastic shall be removed and the remaining assembly shall then be checked for its continued security. If the remaining assembly is still secure, or if no visible cracks are present, it shall be checked again in order to ascertain whether it meets the requirements of 2.4.2, 2.4.3 and 2.6.
2.4.1.5.	The use of materials with properties of polyamide 6 as regards water retention is

**a** Vehicle categories defined in Annex IIA to Directive 70/156/EEC.

**b** OJ L 38, 11.2.1974, p. 2.

**c** OJ L 24, 30.1.1976, p. 6.

**d** OJ L 24, 30.1.1976, p. 6.

**e** OJ L 165, 20.6.1976, p. 16.

**f** In addition to the requirements of 3.1, Member States may, under national law, accept other types of safety belts or restraint systems covered by this Directive for certain vehicle types.

**g** OJ L 221, 12.8.1974, p. 1.

---

**Status:** EU Directives are being published on this site to aid cross referencing from UK legislation. After IP completion day (31 December 2020 11pm) no further amendments will be applied to this version.

	prohibited in all mechanical parts for which such a phenomenon is likely to have an adverse effect on their operation.
2.4.2.	Buckle.
2.4.2.1.	The buckle shall be so designed as to preclude any possibility of incorrect use: this means, <i>inter alia</i> , that it must not be possible for the buckle to be left in a partially-closed position. The procedure for opening the buckle must be obvious. The parts of the buckle likely to contact the body of the wearer shall present a section of not less than 20 cm <sup>2</sup> and at least 46 mm in width, measured in a plane situated at a maximum distance of 2,5 mm from the contact surface. In the case of harness belt buckles, the latter requirement shall be regarded as satisfied if the contact area of the buckle with the wearer's body is comprised between 20 and 40 cm <sup>2</sup> .
2.4.2.2.	<p>The buckle, even when not under load, shall remain closed, whatever its position. It must not be possible to release it with a force less than 1 daN.</p> <p>The buckle shall be so designed as to be easy to use and to grasp. It shall be capable of being released when under the load specified in 2.7.9.2.</p> <p>The buckle shall be released by pressing either a button or a similar device. The surface to which this pressure is applied must have the following dimensions with the button in the release position and when projected into a plane perpendicular to the button's initial direction of motion:</p> <ul style="list-style-type: none"> <li>— for enclosed devices, an area of not less than 4,5 cm<sup>2</sup> and a width of not less than 15 mm,</li> <li>— for non-enclosed devices, an area of not less than 2,5 cm<sup>2</sup> and a width of not less than 10 mm.</li> </ul>
a	Vehicle categories defined in Annex IIA to Directive 70/156/EEC.
b	OJ L 38, 11.2.1974, p. 2.
c	OJ L 24, 30.1.1976, p. 6.
d	OJ L 24, 30.1.1976, p. 6.
e	OJ L 165, 20.6.1976, p. 16.
f	In addition to the requirements of 3.1, Member States may, under national law, accept other types of safety belts or restraint systems covered by this Directive for certain vehicle types.
g	OJ L 221, 12.8.1974, p. 1.



---

*Status: EU Directives are being published on this site to aid cross referencing from UK legislation. After IP completion day (31 December 2020 11pm) no further amendments will be applied to this version.*

---

	This area shall be coloured red. No other part of the buckle shall be of this colour.
2.4.2.3.	The buckle must be capable of withstanding repeated operation and, before the dynamic test referred to in 2.7.8, must undergo 5 000 opening and closing cycles under normal conditions of use. In the case of harness belt buckles, this test may be carried out without all the tongues being introduced.
2.4.2.4.	The buckle, when tested in accordance with 2.7.6.3 shall operate normally.
2.4.2.5.	The force required to open the buckle in the test prescribed in 2.7.9 shall not exceed 6 daN.
2.4.2.6.	The buckle shall be tested for strength in accordance with the requirements of 2.7.6.1 and 2.7.6.5, as appropriate. It must not break, be seriously distorted or become detached when subjected to the prescribed load.
2.4.2.7.	In the case of buckles which incorporate a component common to two assemblies, if the buckle of one assembly can be assembled in use with the mating part of that assembly and with that of the other assembly, the strength and release tests mentioned in 2.7.8 and 2.7.9 shall be carried out for both possible means of assembly.
2.4.3.	Belt-adjusting device.
2.4.3.1.	Two samples of each belt adjusting device shall be tested in accordance with the requirements of 2.7.4. The strap slip shall not exceed 25 mm for each sample of adjusting device and the sum of shifts for all the adjusting devices of a belt shall not exceed 40 mm.
2.4.3.2.	All adjusting devices shall be tested for strength in accordance with 2.7.6.1. They
<b>a</b>	Vehicle categories defined in Annex IIA to Directive 70/156/EEC.
<b>b</b>	<a href="#">OJ L 38, 11.2.1974, p. 2.</a>
<b>c</b>	<a href="#">OJ L 24, 30.1.1976, p. 6.</a>
<b>d</b>	<a href="#">OJ L 24, 30.1.1976, p. 6.</a>
<b>e</b>	<a href="#">OJ L 165, 20.6.1976, p. 16.</a>
<b>f</b>	In addition to the requirements of 3.1, Member States may, under national law, accept other types of safety belts or restraint systems covered by this Directive for certain vehicle types.
<b>g</b>	<a href="#">OJ L 221, 12.8.1974, p. 1.</a>

---

*Status: EU Directives are being published on this site to aid cross referencing from UK legislation. After IP completion day (31 December 2020 11pm) no further amendments will be applied to this version.*

---

	must neither break nor become detached when subjected to the prescribed load.
2.4.3.3.	When a test is carried out in accordance with 2.7.6.6, the force required to operate any manual device shall not exceed 5 daN.
2.4.4.	Attachments and belt adjustment devices for height. The attachments shall be tested for strength as prescribed in items 2.7.6.1 and 2.7.6.2. The actual belt adjustment devices for height shall be tested for strength as prescribed in point 2.7.6.2 of the present Directive where they have not been tested on the vehicle in application of amended council Directive 76/115/EEC <sup>c</sup> relating to anchorages for safety belts. These parts must not break or become detached under the tension set up by the prescribed load.
2.4.5.	Retractors. Retractors shall fulfil the requirements specified below, including the tests for strength prescribed in 2.7.6.1 and 2.7.6.2.
2.4.5.1.	Automatically locking retractors.
2.4.5.1.1.	The strap of a safety belt equipped with an automatically locking retractor shall not move more than 30 mm between the locking positions of the retractor. After a rearward movement by the wearer, the belt must either remain in its initial position or return to that position automatically on subsequent forward movements by the wearer.
2.4.5.1.2.	If the retractor is part of a lap belt, the retracting force of the strap shall be not less than 0,7 daN when measured in the free length between the manikin and the retractor in accordance with 2.7.7.4. If the retractor is part of a diagonal strap the retracting force of the strap shall be not less than 0,2 daN and not more than 0,7 daN when similarly measured. If the strap passes through a
<b>a</b>	Vehicle categories defined in Annex IIA to Directive 70/156/EEC.
<b>b</b>	OJ L 38, 11.2.1974, p. 2.
<b>c</b>	OJ L 24, 30.1.1976, p. 6.
<b>d</b>	OJ L 24, 30.1.1976, p. 6.
<b>e</b>	OJ L 165, 20.6.1976, p. 16.
<b>f</b>	In addition to the requirements of 3.1, Member States may, under national law, accept other types of safety belts or restraint systems covered by this Directive for certain vehicle types.
<b>g</b>	OJ L 221, 12.8.1974, p. 1.

*Status: EU Directives are being published on this site to aid cross referencing from UK legislation. After IP completion day (31 December 2020 11pm) no further amendments will be applied to this version.*

	guide or pulley, the retracting force shall be measured in the frelength between the manikin and the guide or pulley. If the assembly incorporates a device which, upon manual or automatic operation, prevents the strap from being completely retracted, such a device shall not be operated when the retracting force is assessed.
2.4.5.1.3.	The strap shall be withdrawn from the retractor and allowed to retract repeatedly, in accordance with the method described in 2.7.7.1, until 5 000 cycles of withdrawal and retraction have been completed. The retractor shall then be subjected to the corrosion test prescribed in 2.7.2 followed by the dust resistance test described in 2.7.7.3. It shall then satisfactorily complete a further 5 000 cycles after which it shall still meet the requirements of 2.4.5.1.1 and 2.4.5.1.2. After the above tests, the retractor shall still function correctly and stow the strap efficiently.
2.4.5.2.	Emergency locking retractors.
2.4.5.2.1.	An emergency locking retractor shall satisfy the following conditions when tested in accordance with 2.7.7.2. In the case of a single sensitivity, according to point 1.8.4.1, only the specifications regarding deceleration of the vehicle are valid.
2.4.5.2.1.1.	It shall have locked when the vehicle deceleration reaches a value of 0,45 g in the case of type 4 or 0,85 g in the case of type 4N retractors.
2.4.5.2.1.2.	It shall not lock at strap accelerations, measured in the direction of unreeling, of less than 0,8 g in the case of type 4 or less than 1,0 g in the case of type 4N retractors.
2.4.5.2.1.3.	In addition, it shall not lock when the sensor is inclined at an angle not exceeding 12° in
a	Vehicle categories defined in Annex IIA to Directive 70/156/EEC.
b	OJ L 38, 11.2.1974, p. 2.
c	OJ L 24, 30.1.1976, p. 6.
d	OJ L 24, 30.1.1976, p. 6.
e	OJ L 165, 20.6.1976, p. 16.
f	In addition to the requirements of 3.1, Member States may, under national law, accept other types of safety belts or restraint systems covered by this Directive for certain vehicle types.
g	OJ L 221, 12.8.1974, p. 1.

---

*Status: EU Directives are being published on this site to aid cross referencing from UK legislation. After IP completion day (31 December 2020 11pm) no further amendments will be applied to this version.*

---

	any direction from the installation position specified by the manufacturer.
2.4.5.2.1.4.	It shall lock when the sensor is inclined to an angle of not less than 27° in the case of type 4 or not less than 40° in the case of type 4N retractors in any direction from the installation position specified by the manufacturer.
2.4.5.2.1.5.	If operation of the retractor is dependent on an external signal or energy source, the device shall ensure automatic locking of the retractor in the event of the failure or interruption of the signal or energy source. However, this requirement need not be met in the case of a retractor with multiple sensitivities provided that only one sensitivity is dependent on an external signal or power source and the failure of the signal or power source is indicated to the driver by optical and/or acoustical means.
2.4.5.2.2.	When tested in accordance with 2.7.7.2, an emergency locking retractor with multiple sensitivity, including strap sensitivity, shall comply with the specified requirements and also lock up when strap acceleration measured in the direction of unreeling is not less than 2,0 g.
2.4.5.2.3.	In each of the tests mentioned in 2.4.5.2.1 and 2.4.5.2.2, the amount of strap movement which may occur before the retractor locks shall not exceed 50 mm, starting at the length specified in 2.7.7.2.1. In order to comply with the requirements of 2.4.5.2.1.2, a retractor shall be considered as satisfactory if, at the strap acceleration values prescribed in that point, it does not lock until at least the first 50 mm of strap has been unwound, starting at the length specified in 2.7.7.2.1.
2.4.5.2.4.	If the retractor is part of a lap belt, the retracting force of the strap shall be not less
<b>a</b>	Vehicle categories defined in Annex IIA to Directive 70/156/EEC.
<b>b</b>	OJ L 38, 11.2.1974, p. 2.
<b>c</b>	OJ L 24, 30.1.1976, p. 6.
<b>d</b>	OJ L 24, 30.1.1976, p. 6.
<b>e</b>	OJ L 165, 20.6.1976, p. 16.
<b>f</b>	In addition to the requirements of 3.1, Member States may, under national law, accept other types of safety belts or restraint systems covered by this Directive for certain vehicle types.
<b>g</b>	OJ L 221, 12.8.1974, p. 1.

*Status: EU Directives are being published on this site to aid cross referencing from UK legislation. After IP completion day (31 December 2020 11pm) no further amendments will be applied to this version.*

	<p>than 0,7 daN when measured in the free length between the manikin and the retractor, in accordance with 2.7.7.4. If the retractor is part of a diagonal strap; the retracting force of the strap shall be not less than 0,2 daN and not more than 0,7 daN when similarly measured. If the strap passes through a guide or pulley, the retracting force shall be measured in the free length between the manikin and the guide or pulley if the assembly incorporates a device which, upon manual or automatic operation, prevents the strap from being completely retracted, such a device shall not be operated when the retracting force is assessed.</p>
2.4.5.2.5.	<p>The strap shall be withdrawn from the retractor and allowed to retract repeatedly in accordance with the method described in 2.7.7.1 until 40 000 cycles of withdrawal and retraction have been completed. The retractor shall then be subjected to the corrosion test prescribed in 2.7.2 followed by the dust resistance test described in 2.7.7.3. It shall then satisfactorily complete a further 5 000 cycles of withdrawal and retraction, after which it shall still meet the requirements of 2.4.5.2.1, 2.4.5.2.2, 2.4.5.2.3 and 2.4.5.2.4. After the above tests, the retractor shall still function correctly and stow the strap efficiently.</p>
2.4.6.	<p>Pre-loading device.</p>
2.4.6.1.	<p>After being submitted to corrosion testing in accordance with item 2.7.2, the pre-loading device (including the impact sensor connected to the device by the original plugs but without any current passing through them) shall operate normally.</p>
2.4.6.2.	<p>It shall be verified that inadvertent operation of the device does not involve any risk of bodily injury for the wearer.</p>
<b>a</b>	Vehicle categories defined in Annex IIA to Directive 70/156/EEC.
<b>b</b>	OJ L 38, 11.2.1974, p. 2.
<b>c</b>	OJ L 24, 30.1.1976, p. 6.
<b>d</b>	OJ L 24, 30.1.1976, p. 6.
<b>e</b>	OJ L 165, 20.6.1976, p. 16.
<b>f</b>	In addition to the requirements of 3.1, Member States may, under national law, accept other types of safety belts or restraint systems covered by this Directive for certain vehicle types.
<b>g</b>	OJ L 221, 12.8.1974, p. 1.

---

*Status: EU Directives are being published on this site to aid cross referencing from UK legislation. After IP completion day (31 December 2020 11pm) no further amendments will be applied to this version.*

---

2.4.6.3.	In the case of pyrotechnic pre-loading devices.
2.4.6.3.1.	After being submitted to conditioning in accordance with item 2.7.10.2, operation of the pre-loading device must not have been activated by temperature and the device shall operate normally.
2.4.6.3.2.	Precautions shall be taken to prevent the hot gases expelled from igniting adjacent flammable materials.
2.5.	Straps.
2.5.1.	General.
2.5.1.1.	The characteristics of the straps shall be such as to ensure that their pressure on the wearer's body is distributed as evenly as possible over their whole width and that they do not twist, even under load. They shall have energy-absorbing and energy-dispersing capacities. The straps shall have finished salvages which shall not become unravelled in use.
2.5.1.2.	The width of the straps under a load of 980 daN shall not be less than 46 mm. This dimension shall be measured during the breaking-strength test prescribed in 2.7.5, and without stopping the machine.
2.5.2.	Strength after room-conditioning. In the case of the two strap samples conditioned in conformity with 2.7.3.1, the breaking load of the strap, determined in accordance with 2.7.5, shall be not less than 1 470 daN. The difference between the breaking loads of the two samples shall not exceed 10 % of the greater of the breaking loads measured.
2.5.3.	Strength after special conditioning. In the case of the two strap samples conditioned in conformity with one of the provisions of 2.7.3 (except 2.7.3.1),
<b>a</b>	Vehicle categories defined in Annex IIA to Directive 70/156/EEC.
<b>b</b>	<a href="#">OJ L 38, 11.2.1974, p. 2.</a>
<b>c</b>	<a href="#">OJ L 24, 30.1.1976, p. 6.</a>
<b>d</b>	<a href="#">OJ L 24, 30.1.1976, p. 6.</a>
<b>e</b>	<a href="#">OJ L 165, 20.6.1976, p. 16.</a>
<b>f</b>	In addition to the requirements of 3.1, Member States may, under national law, accept other types of safety belts or restraint systems covered by this Directive for certain vehicle types.
<b>g</b>	<a href="#">OJ L 221, 12.8.1974, p. 1.</a>

*Status: EU Directives are being published on this site to aid cross referencing from UK legislation. After IP completion day (31 December 2020 11pm) no further amendments will be applied to this version.*

	the breaking load of the strap shall be not less than 75 % of the average of the loads determined in the test referred to in 2.5.2, and not less than 1 470 daN. The technical service may dispense with one or more of these tests if the composition of the material used, or information already available, renders the test or tests superfluous.
2.6.	Belt assembly or restraint system.
2.6.1.	Requirements for dynamic testing.
2.6.1.1.	The belt assembly or restraint system shall be subjected to a dynamic test in conformity with 2.7.8.
2.6.1.2.	The dynamic test shall be performed on two belt assemblies which have not previously been under load, except in the case of belt assemblies forming part of restraint systems, when the dynamic test shall be performed on the restraint systems intended for one group of seats which have not previously been under load. The buckles of the belts to be tested shall satisfy the requirements set out in point 2.4.2.3. In the case of safety belts with retractors, the retractor shall have been subjected to the dust resistance test laid down in point 2.7.7.3; in addition, in the case of safety belts or restraint system equipped with a pre-loading device comprising pyrotechnic means, the device shall have been subjected to the conditioning specified in point 2.7.10.2.
2.6.1.2.1.	The belts shall have undergone the corrosion test defined in point 2.7.2, after which the buckles shall be subjected to a further 500 opening and closing cycles under normal conditions of use.
2.6.1.2.2.	In the case of safety belts with retractors, the latter shall have been subjected to the tests described in points 2.4.5.1 or 2.4.5.2. If, however, a retractor has already been
<b>a</b>	Vehicle categories defined in Annex IIA to Directive 70/156/EEC.
<b>b</b>	OJ L 38, 11.2.1974, p. 2.
<b>c</b>	OJ L 24, 30.1.1976, p. 6.
<b>d</b>	OJ L 24, 30.1.1976, p. 6.
<b>e</b>	OJ L 165, 20.6.1976, p. 16.
<b>f</b>	In addition to the requirements of 3.1, Member States may, under national law, accept other types of safety belts or restraint systems covered by this Directive for certain vehicle types.
<b>g</b>	OJ L 221, 12.8.1974, p. 1.

---

**Status:** EU Directives are being published on this site to aid cross referencing from UK legislation. After IP completion day (31 December 2020 11pm) no further amendments will be applied to this version.

---

	subjected to the corrosion test pursuant to the provisions of point 2.6.1.2.1, this test need not be repeated.
2.6.1.2.3.	In the case of a belt intended for use with a belt adjustment device for height, as defined in point 1.8.6 above, the test shall be carried out with the device adjusted in the most unfavourable position(s) chosen by the technical service responsible for testing. However if the adjustment device for height consists of the anchorage itself, as permitted by Council Directive 76/115/EEC <sup>d</sup> , the technical service responsible for the tests can, if it so wishes, apply the provisions of point 2.7.8.1 hereafter.
2.6.1.2.4.	In the case of a safety belt with a pre-loading device the minimum displacement specified in point 2.6.1.4.1 below may be reduced by half. For the purpose of this text, the pre-loading device shall be in operation.
2.6.1.3.	During this test, the following requirements shall be met:
2.6.1.3.1.	no part of a belt assembly or a restraint system securing the occupant shall break and no buckle or locking or displacement system shall unlock; and
2.6.1.3.2.	the forward displacement of the manikin shall be between 80 and 200 mm at pelvic level in the case of lap belts. In case of a harness belt the minimum displacement specified for the pelvis may be reduced by half. In the case of other types of belt, the forward displacement shall be between 80 and 200 mm at pelvic level and between 100 and 300 mm at torso level. These displacements are the displacements in relation to the measurement points shown in Annex VIII, Figure 6.
2.6.1.3.3.	In the case of a safety belt intended to be used in an outboard front seating position
<b>a</b>	Vehicle categories defined in Annex IIA to Directive 70/156/EEC.
<b>b</b>	OJ L 38, 11.2.1974, p. 2.
<b>c</b>	OJ L 24, 30.1.1976, p. 6.
<b>d</b>	OJ L 24, 30.1.1976, p. 6.
<b>e</b>	OJ L 165, 20.6.1976, p. 16.
<b>f</b>	In addition to the requirements of 3.1, Member States may, under national law, accept other types of safety belts or restraint systems covered by this Directive for certain vehicle types.
<b>g</b>	OJ L 221, 12.8.1974, p. 1.



---

**Status:** EU Directives are being published on this site to aid cross referencing from UK legislation. After IP completion day (31 December 2020 11pm) no further amendments will be applied to this version.

---

	protected by an airbag in front of it, the displacement of the chest reference point may exceed that specified in paragraph 2.6.1.3.2 above if its speed at this value does not exceed 24 km/h.
2.6.1.4.	In the case of a restraint system:
2.6.1.4.1.	the movement of the chest reference point may exceed that specified in 2.6.1.3.2 if it can be shown, either by calculation or by a further test, that no part of the torso or the head of the manikin used in the dynamic test would have come into contact with any forward rigid part of the vehicle, apart from contact of the chest with the steering assembly, if the latter meets the requirements of Council Directive 74/297/EEC <sup>e</sup> and provided that contact does not occur at a speed higher than 24 km/h. For this assessment, the seat shall be considered to be in the position specified in 2.7.8.1.5.
2.6.1.4.2.	In vehicles where such devices are used, the displacement and locking systems enabling the occupants of all seats to leave the vehicle shall still be operable by hand after the dynamic test.
2.6.1.5.	By way of derogation, in the case of a restraint system, the displacements may be greater than those specified in point 2.6.1.3.2 in the case where the upper anchorage fitted to the seat profits by the derogation provided in point 5.5.4 of Annex I to Directive 76/115/EEC. Details of the restraint system concerned shall be included in the Addendum to the type-approval certificate referred to in Appendices 3 and 4 to Annex II.
2.6.2.	Strength after abrasion procedure.
2.6.2.1.	For both samples conditioned in conformity with 2.7.3.6, the breaking load shall be assessed in accordance with 2.5.2 and 2.7.6.
<b>a</b>	Vehicle categories defined in Annex IIA to Directive 70/156/EEC.
<b>b</b>	OJ L 38, 11.2.1974, p. 2.
<b>c</b>	OJ L 24, 30.1.1976, p. 6.
<b>d</b>	OJ L 24, 30.1.1976, p. 6.
<b>e</b>	OJ L 165, 20.6.1976, p. 16.
<b>f</b>	In addition to the requirements of 3.1, Member States may, under national law, accept other types of safety belts or restraint systems covered by this Directive for certain vehicle types.
<b>g</b>	OJ L 221, 12.8.1974, p. 1.

*Status: EU Directives are being published on this site to aid cross referencing from UK legislation. After IP completion day (31 December 2020 11pm) no further amendments will be applied to this version.*

	It shall be at least equal to 75 % of the average of the breaking loads determined during tests on unabraded straps, and not less than the minimum load specified for the items being tested. The difference between the breaking loads of the two samples shall not exceed 20 % of the greater of the breaking loads measured. In the type 1 and type 2 procedures, the tensile-strength test shall be conducted on the strap samples only (point 2.7.5). In type 3 procedures, the tensile-strength test shall be conducted on the strap and relevant rigid parts (point 2.7.6).																								
2.6.2.2.	<p>The items to be subjected to an abrasion procedure and the procedures to be followed are indicated in the following table. A new sample shall be used for each procedure.</p> <table border="1"> <thead> <tr> <th></th> <th>Type 1 procedure</th> <th>Type 2 procedure</th> <th>Type 3 procedure</th> </tr> </thead> <tbody> <tr> <td><b>Attachment</b></td> <td>—</td> <td>—</td> <td>×</td> </tr> <tr> <td><b>Guide or pulley</b></td> <td>—</td> <td>×</td> <td>—</td> </tr> <tr> <td><b>Buckle loop</b></td> <td>—</td> <td>×</td> <td>×</td> </tr> <tr> <td><b>Adjusting device</b></td> <td>×</td> <td>—</td> <td>×</td> </tr> <tr> <td><b>Parts sewn to the strap</b></td> <td>—</td> <td>—</td> <td>×</td> </tr> </tbody> </table>		Type 1 procedure	Type 2 procedure	Type 3 procedure	<b>Attachment</b>	—	—	×	<b>Guide or pulley</b>	—	×	—	<b>Buckle loop</b>	—	×	×	<b>Adjusting device</b>	×	—	×	<b>Parts sewn to the strap</b>	—	—	×
	Type 1 procedure	Type 2 procedure	Type 3 procedure																						
<b>Attachment</b>	—	—	×																						
<b>Guide or pulley</b>	—	×	—																						
<b>Buckle loop</b>	—	×	×																						
<b>Adjusting device</b>	×	—	×																						
<b>Parts sewn to the strap</b>	—	—	×																						
2.7.	Tests.																								
2.7.1.	Use of samples submitted for EC component type-approval of a type of belt or restraint system (see Annex XIV).																								
2.7.1.1.	Two belts or restraint systems are required for the buckle inspection, the low-temperature buckle test, the low-temperature test described in point 2.7.6.4 where																								
<b>a</b>	Vehicle categories defined in Annex IIA to Directive 70/156/EEC.																								
<b>b</b>	OJ L 38, 11.2.1974, p. 2.																								
<b>c</b>	OJ L 24, 30.1.1976, p. 6.																								
<b>d</b>	OJ L 24, 30.1.1976, p. 6.																								
<b>e</b>	OJ L 165, 20.6.1976, p. 16.																								
<b>f</b>	In addition to the requirements of 3.1, Member States may, under national law, accept other types of safety belts or restraint systems covered by this Directive for certain vehicle types.																								
<b>g</b>	OJ L 221, 12.8.1974, p. 1.																								

*Status: EU Directives are being published on this site to aid cross referencing from UK legislation. After IP completion day (31 December 2020 11pm) no further amendments will be applied to this version.*

	necessary, the buckle durability test, the belt corrosion test, the retractor operating tests and the buckle-opening test after the dynamic test. One of these two samples shall be used for the inspection of the belt or restraint system.
2.7.1.2.	One belt or restraint system is required for the inspection of the buckle and the strength tests on the buckle, the attachment mountings, the belt adjusting devices and, where necessary, the retractors.
2.7.1.3.	Two belts or restraint systems are required for the inspection of the buckle, the micro-slip test and the abrasion test. The belt adjustment device operating test shall be conducted on one of the two samples.
2.7.1.4.	The sample of strap shall be used for testing the breaking strength of the strap. Part of this sample shall be preserved for as long as the component type-approval remains valid.
2.7.2.	Corrosion test.
2.7.2.1.	A complete safety belt assembly shall be positioned in a test chamber as prescribed in Annex XIII. In the case of an assembly incorporating a retractor, the strap shall be unwound to full length, less $300 \pm 3$ mm. Except for short interruptions that may be necessary, e.g. for checking and replenishing the salt solution, the exposure test shall proceed continuously for a period of 50 hours.
2.7.2.2.	On completion of the exposure test, the assembly shall be gently washed or dipped in clean running water at a temperature not exceeding $38^{\circ}\text{C}$ so as to remove any salt deposit that may have formed, and then allowed to dry at room temperature for 24 hours before being inspected in accordance with 2.4.1.2.
<b>a</b>	Vehicle categories defined in Annex IIA to Directive 70/156/EEC.
<b>b</b>	OJ L 38, 11.2.1974, p. 2.
<b>c</b>	OJ L 24, 30.1.1976, p. 6.
<b>d</b>	OJ L 24, 30.1.1976, p. 6.
<b>e</b>	OJ L 165, 20.6.1976, p. 16.
<b>f</b>	In addition to the requirements of 3.1, Member States may, under national law, accept other types of safety belts or restraint systems covered by this Directive for certain vehicle types.
<b>g</b>	OJ L 221, 12.8.1974, p. 1.

*Status: EU Directives are being published on this site to aid cross referencing from UK legislation. After IP completion day (31 December 2020 11pm) no further amendments will be applied to this version.*

[ <sup>X1</sup> 2.7.3.	Conditioning of straps for the breaking-strength test. Samples cut from the strap, as referred to in 2.1.3.2, shall be conditioned as follows.]
2.7.3.1.	Room-conditioning. The strap shall be kept for a minimum of 24 hours in an atmosphere having a temperature of $20 \pm 5$ °C and a relative humidity of $65 \pm 5$ %. If the test is not carried out immediately after conditioning, the sample shall be placed in an hermetically sealed receptacle until the test begins. The breaking load shall be determined within five minutes of the strap's removal from the conditioning atmosphere or receptacle.
2.7.3.2.	Light-conditioning.
2.7.3.2.1.	The provisions of Recommendation ISO/R 105-B 02-1978 shall apply. The strap shall be exposed to light for the time necessary to produce fading of standard blue dye type 7 to a contrast equal to grade four on the grey scale.
2.7.3.2.2.	The strap shall then be kept for a minimum of 24 hours at an air temperature of $20 \pm 5$ °C and a relative humidity of $65 \pm 5$ %. If the test cannot be carried out immediately after the conditioning, the sample shall be kept in an hermetically sealed container until the start of the test. The tensile strength of the strap shall be determined within five minutes of its removal from the conditioning atmosphere or receptacle.
2.7.3.3.	Cold-conditioning.
2.7.3.3.1.	The strap shall be kept for a minimum of 24 hours in an atmosphere having a temperature of $20 \pm 5$ °C and a relative humidity of $65 \pm 5$ %.
a	Vehicle categories defined in Annex IIA to Directive 70/156/EEC.
b	OJ L 38, 11.2.1974, p. 2.
c	OJ L 24, 30.1.1976, p. 6.
d	OJ L 24, 30.1.1976, p. 6.
e	OJ L 165, 20.6.1976, p. 16.
f	In addition to the requirements of 3.1, Member States may, under national law, accept other types of safety belts or restraint systems covered by this Directive for certain vehicle types.
g	OJ L 221, 12.8.1974, p. 1.

*Status: EU Directives are being published on this site to aid cross referencing from UK legislation. After IP completion day (31 December 2020 11pm) no further amendments will be applied to this version.*

2.7.3.3.2.	The strap shall then be kept for one and a half hours on a plane surface in a low-temperature chamber in which the air temperature is $-30 \pm 5$ °C. It shall then be folded and the fold shall be loaded with a mass of 2 kg previously cooled to $-30 \pm 5$ °C. When the strap has been kept under load for 30 minutes in the same low-temperature chamber, the mass shall be removed and the breaking load shall be measured within five minutes of the strap's removal from the low-temperature chamber.
2.7.3.4.	Heat-conditioning.
2.7.3.4.1.	The strap shall be kept for three hours in a heating cabinet in an atmosphere having a temperature of $60 \pm 5$ °C and a relative humidity of $65 \pm 5$ %.
2.7.3.4.2.	The breaking load shall be determined within five minutes of the strap's removal from the heating cabinet.
2.7.3.5.	Exposure to water.
2.7.3.5.1.	The strap shall be kept fully immersed for three hours in distilled water, at a temperature of $20 \pm 5$ °C, to which a trace of a wetting agent, has been added. Any wetting agent suitable for the fibre under test may be used.
2.7.3.5.2.	The breaking load shall be determined within 10 minutes of the strap's removal from the water.
2.7.3.6.	Conditioning by abrasion.
2.7.3.6.1.	The abrasion procedure shall be performed on every device in which the strap is in contact with a rigid part of the belt. However, the type 1 abrasion test (2.7.3.6.4.1) need not be carried out on the belt-adjusting device where the micro-slip test (2.7.4) shows that the strap slips less than half the prescribed
a	Vehicle categories defined in Annex IIA to Directive 70/156/EEC.
b	OJ L 38, 11.2.1974, p. 2.
c	OJ L 24, 30.1.1976, p. 6.
d	OJ L 24, 30.1.1976, p. 6.
e	OJ L 165, 20.6.1976, p. 16.
f	In addition to the requirements of 3.1, Member States may, under national law, accept other types of safety belts or restraint systems covered by this Directive for certain vehicle types.
g	OJ L 221, 12.8.1974, p. 1.

*Status: EU Directives are being published on this site to aid cross referencing from UK legislation. After IP completion day (31 December 2020 11pm) no further amendments will be applied to this version.*

	amount. The setting on the test apparatus shall approximately maintain the relative position of strap and contact area.																				
2.7.3.6.2.	The samples to be subjected to abrasion shall be kept for a minimum of 24 hours in an atmosphere having a temperature of $20 \pm 5$ °C and a relative humidity of $65 \pm 5$ %. The room temperature during testing shall be between 15 and 30 °C.																				
2.7.3.6.3.	The table below sets out the requirements for each abrasion procedure:																				
	<table border="1"> <thead> <tr> <th></th> <th>Load (daN)</th> <th>Frequency (Hz)</th> <th>No of cycles</th> <th>Shift (mm)</th> </tr> </thead> <tbody> <tr> <td><b>Type 1 procedure</b></td> <td>2,5</td> <td>0,5</td> <td>5 000</td> <td><math>300 \pm 20</math></td> </tr> <tr> <td><b>Type 2 procedure</b></td> <td>0,5</td> <td>0,5</td> <td>45 000</td> <td><math>300 \pm 20</math></td> </tr> <tr> <td><b>Type 3 procedure<sup>h</sup></b></td> <td>0 - 5</td> <td>0,5</td> <td>45 000</td> <td>—</td> </tr> </tbody> </table> <p><sup>h</sup> See 2.7.3.6.4.3.</p>		Load (daN)	Frequency (Hz)	No of cycles	Shift (mm)	<b>Type 1 procedure</b>	2,5	0,5	5 000	$300 \pm 20$	<b>Type 2 procedure</b>	0,5	0,5	45 000	$300 \pm 20$	<b>Type 3 procedure<sup>h</sup></b>	0 - 5	0,5	45 000	—
	Load (daN)	Frequency (Hz)	No of cycles	Shift (mm)																	
<b>Type 1 procedure</b>	2,5	0,5	5 000	$300 \pm 20$																	
<b>Type 2 procedure</b>	0,5	0,5	45 000	$300 \pm 20$																	
<b>Type 3 procedure<sup>h</sup></b>	0 - 5	0,5	45 000	—																	
	The shift given in the fifth column of this table represents the amplitude of a back-and-forth motion applied to the strap.																				
2.7.3.6.4.	Particular procedure conditions.																				
2.7.3.6.4.1.	Type 1 procedure: for cases where the strap slides through an adjusting device. The 2,5 daN load shall be vertically and permanently applied to one section of the strap. The other section, set horizontally, shall be subjected to a back-and-forth motion. The adjusting device shall be so placed that the horizontal section of the strap shall remain under load (see Annex XII, Figure 1).																				
<b>a</b>	Vehicle categories defined in Annex IIA to Directive 70/156/EEC.																				
<b>b</b>	OJ L 38, 11.2.1974, p. 2.																				
<b>c</b>	OJ L 24, 30.1.1976, p. 6.																				
<b>d</b>	OJ L 24, 30.1.1976, p. 6.																				
<b>e</b>	OJ L 165, 20.6.1976, p. 16.																				
<b>f</b>	In addition to the requirements of 3.1, Member States may, under national law, accept other types of safety belts or restraint systems covered by this Directive for certain vehicle types.																				
<b>g</b>	OJ L 221, 12.8.1974, p. 1.																				

*Status: EU Directives are being published on this site to aid cross referencing from UK legislation. After IP completion day (31 December 2020 11pm) no further amendments will be applied to this version.*

2.7.3.6.4.2.	Type 2 procedure: in cases where the strap changes direction once in passing through a rigid part. The angles which both strap ends make with each other must be as shown in Annex XII, Figure 2. A permanent load of 0,5 daN must be applied. If the strap changes direction more than once on passing through a rigid part, the 0,5 daN load may be increased so as to achieve the prescribed 300 mm of strap movement through that rigid part.
2.7.3.6.4.3.	Type 3 procedure: for cases where the strap is fixed to a rigid part by sewing or similar means. The total shift shall be $300 \pm 20$ mm and the 5 daN load shall be applied only during the time corresponding to a shift of $100 \pm 20$ mm for each half period (see Annex XII, Figure 3).
2.7.4.	Micro-slip test (see Annex XII, Figure 3).
2.7.4.1.	The components or devices to be subjected to the micro-slip test shall be kept for a minimum of 24 hours before testing in an atmosphere having a temperature of $20 \pm 5$ °C and a relative humidity of $65 \pm 5$ %. The test shall be carried out at a temperature between 15 and 30 °C.
2.7.4.2.	It shall be ensured that the free section of the adjusting device points either up or down on the test bench, as in the vehicle.
2.7.4.3.	A 5 daN load shall be attached to the lower end of the section of strap. The other end shall be subjected to a back-and-forth motion the total amplitude being $300 \pm 20$ mm (see figure).
2.7.4.4.	If there is a free end serving as reserve strap, it must in no way be fastened or clipped to the section under load.
a	Vehicle categories defined in Annex IIA to Directive 70/156/EEC.
b	OJ L 38, 11.2.1974, p. 2.
c	OJ L 24, 30.1.1976, p. 6.
d	OJ L 24, 30.1.1976, p. 6.
e	OJ L 165, 20.6.1976, p. 16.
f	In addition to the requirements of 3.1, Member States may, under national law, accept other types of safety belts or restraint systems covered by this Directive for certain vehicle types.
g	OJ L 221, 12.8.1974, p. 1.

---

*Status: EU Directives are being published on this site to aid cross referencing from UK legislation. After IP completion day (31 December 2020 11pm) no further amendments will be applied to this version.*

---

2.7.4.5.	It shall be ensured that on the test bench the strap, in the slack position, descends in a concave curve from the adjusting device, as in the vehicle. The 5 daN load applied on the test bench shall be guided vertically in such a way as to prevent the load swaying and the belt twisting. The attachment shall be fixed to the 5 daN load as in the vehicle.
2.7.4.6.	Before the actual start of the test, a series of 20 cycles shall be completed so that the self-tightening system settles properly.
2.7.4.7.	1 000 cycles shall be completed at a frequency of 0,5 cycle per second, the total amplitude being $300 \pm 20$ mm. The 5 daN load shall be applied only during the time corresponding to a shift of $100 \pm 20$ mm for each half period.
2.7.5.	Test of breaking strength of strap (static test).
2.7.5.1.	The test shall be carried out each time on two new samples of strap, of sufficient length, conditioned in accordance with one of the provisions of 2.7.3.
2.7.5.2.	Each strap shall be gripped between the clamps of a tensile-testing machine. The clamps shall be so designed as to avoid breakage of the strap at or near the point of contact with the clamps. The speed of traverse shall be about 100 mm per minute. The free length of the sample between the clamps of the machine at the start of the test shall be $200 \pm 40$ mm.
2.7.5.3.	When the load reaches 980 daN, the width of the strap shall be measured without stopping the machine.
2.7.5.4.	The load shall then be increased until the strap breaks, and the breaking load shall be noted.

**a** Vehicle categories defined in Annex IIA to Directive 70/156/EEC.

**b** OJ L 38, 11.2.1974, p. 2.

**c** OJ L 24, 30.1.1976, p. 6.

**d** OJ L 24, 30.1.1976, p. 6.

**e** OJ L 165, 20.6.1976, p. 16.

**f** In addition to the requirements of 3.1, Member States may, under national law, accept other types of safety belts or restraint systems covered by this Directive for certain vehicle types.

**g** OJ L 221, 12.8.1974, p. 1.



---

*Status: EU Directives are being published on this site to aid cross referencing from UK legislation. After IP completion day (31 December 2020 11pm) no further amendments will be applied to this version.*

---

2.7.5.5.	If the strap slips or breaks at the point of contact with one of the clamps or within 10 mm of either of them, the test shall be invalid and a new test shall be carried out on another sample.
2.7.6.	Static test of belt components incorporating rigid parts.
2.7.6.1.	The buckle and strap adjusting device must be connected to the tensile-testing machine by their normal attachments and a load of 980 daN must be applied. In the case of harness belts, the buckle shall be connected to the testing apparatus by the straps which are attached to the buckle and the tongue or two tongues located in an approximately symmetrical way to the geometric centre of the buckle. If the buckle or adjusting device is part of the attachment or of the common component of a three-point strap, the buckle or adjusting device must be tested together with the attachment in accordance with point 2.7.6.2, except in the case of retractors with a return pulley at the upper strap anchorage. In this case the test load must be 980 daN and the length of strap remaining on the reel at the moment of locking must be as close as possible to 450 mm.
2.7.6.2.	The attachments and any belt adjustment devices for height shall be tested in the manner described in 2.7.6.1, but the load shall be 1 470 daN and, subject to the provisions of the second sentence of 2.7.8.1, shall be applied in the least favourable conditions likely to occur in a vehicle in which the belt is correctly installed. In the case of retractors, the test shall be performed with the strap completely unwound from the reel.
2.7.6.3.	Two samples of the complete belt assembly shall be placed in a low-temperature chamber
<b>a</b>	Vehicle categories defined in Annex IIA to Directive 70/156/EEC.
<b>b</b>	<a href="#">OJ L 38, 11.2.1974, p. 2.</a>
<b>c</b>	<a href="#">OJ L 24, 30.1.1976, p. 6.</a>
<b>d</b>	<a href="#">OJ L 24, 30.1.1976, p. 6.</a>
<b>e</b>	<a href="#">OJ L 165, 20.6.1976, p. 16.</a>
<b>f</b>	In addition to the requirements of 3.1, Member States may, under national law, accept other types of safety belts or restraint systems covered by this Directive for certain vehicle types.
<b>g</b>	<a href="#">OJ L 221, 12.8.1974, p. 1.</a>

---

*Status: EU Directives are being published on this site to aid cross referencing from UK legislation. After IP completion day (31 December 2020 11pm) no further amendments will be applied to this version.*

---

	at $-10 \pm 1$ °C for two hours. Immediately after being removed from the chamber the mating parts of the buckle shall then be locked together manually.
2.7.6.4.	Two samples of the complete belt assembly shall be placed in a low-temperature chamber at a temperature of $-10 \pm 1$ °C for two hours. All rigid items and parts made of plastic under test shall then be laid in turn on a flat steel surface (which has been kept with the samples in the low temperature chamber), placed on the horizontal surface of a compact rigid block with a mass of at least 100 kg; within 30 seconds of their being removed from the low-temperature chamber, an 18 kg steel mass shall be allowed to fall under gravity from a height of 300 mm onto the item. The impact face of the mass shall have a hardness of at least 45 HRC and take the form of a convex surface having a transverse radius of 10 mm and a longitudinal radius of 150 mm. One sample shall be tested with the axis of the curved bar in line with the strap, and the other sample shall be tested at $90^\circ$ to the strap.
2.7.6.5.	Buckles having parts common to two safety belts shall be loaded in such a way as to simulate the conditions of use in a vehicle with the seats in the mid-position of their adjustment. The direction of application of the load shall be established in accordance with 2.7.8.1. A load of 1 470 daN shall be applied simultaneously to each of the straps. Suitable apparatus for the above test is shown in Annex XI.
2.7.6.6.	When testing any manual adjusting device, the strap shall be drawn steadily through that device, having regard to normal conditions of use, at a rate of approximately 100 mm/s, and the maximum force shall be measured to the nearest 0,1 daN after the first 25 mm
<b>a</b>	Vehicle categories defined in Annex IIA to Directive 70/156/EEC.
<b>b</b>	OJ L 38, 11.2.1974, p. 2.
<b>c</b>	OJ L 24, 30.1.1976, p. 6.
<b>d</b>	OJ L 24, 30.1.1976, p. 6.
<b>e</b>	OJ L 165, 20.6.1976, p. 16.
<b>f</b>	In addition to the requirements of 3.1, Member States may, under national law, accept other types of safety belts or restraint systems covered by this Directive for certain vehicle types.
<b>g</b>	OJ L 221, 12.8.1974, p. 1.

---

*Status: EU Directives are being published on this site to aid cross referencing from UK legislation. After IP completion day (31 December 2020 11pm) no further amendments will be applied to this version.*

---

	of strap movement. The test shall be carried out in both directions of strap travel through the adjusting device, the strap being cycled 10 times prior to measurement.
2.7.7.	Additional tests for retractors.
2.7.7.1.	Durability of retractor mechanism.
2.7.7.1.1.	The strap shall be withdrawn and allowed to retract for the required number of cycles at a rate of not more than 30 cycles per minute. In the case of emergency locking retractors, a snatch shall be introduced at each fifth cycle to lock the retractor. The snatches shall occur in equal numbers at each of five different extractions, namely, 90, 80, 75, 70 and 65 % of the total length of the strap on the retractor. However, where more than 900 mm is provided, the above percentages shall be related to the final 900 mm of strap which remain wound on the retractor.
2.7.7.1.2.	Suitable apparatus for the tests specified in 2.7.7.1.1 is shown in Annex IV.
2.7.7.2.	Locking of emergency locking retractors.
2.7.7.2.1.	The retractor shall be tested for locking when $300 \pm 3$ mm of strap remain wound on the retractor reel.
2.7.7.2.1.1.	In the case of a locking retractor actuated by strap movement, the extraction shall be in the direction in which it normally occurs when the retractor is installed in a vehicle.
2.7.7.2.1.2.	When retractors are being tested for sensitivity to vehicle deceleration, they shall be tested at the above extraction in both directions along two mutually perpendicular axes, which are horizontal if the retractor is to be installed in a vehicle as specified by the safety belt manufacturer. One of these test directions shall be chosen by the technical service conducting the approval test so as to
a	Vehicle categories defined in Annex IIA to Directive 70/156/EEC.
b	<a href="#">OJ L 38, 11.2.1974, p. 2.</a>
c	<a href="#">OJ L 24, 30.1.1976, p. 6.</a>
d	<a href="#">OJ L 24, 30.1.1976, p. 6.</a>
e	<a href="#">OJ L 165, 20.6.1976, p. 16.</a>
f	In addition to the requirements of 3.1, Member States may, under national law, accept other types of safety belts or restraint systems covered by this Directive for certain vehicle types.
g	<a href="#">OJ L 221, 12.8.1974, p. 1.</a>

*Status: EU Directives are being published on this site to aid cross referencing from UK legislation. After IP completion day (31 December 2020 11pm) no further amendments will be applied to this version.*

	give the most adverse conditions with respect to actuation of the locking mechanism.
2.7.7.2.2.	Suitable apparatus for the tests specified in 2.7.7.2.1 is described in Annex V. The design of any such test apparatus shall ensure that the required acceleration is achieved before the webbing is drawn out of the retractor by more than 5 mm and that the withdrawal takes place at an average rate of increase of acceleration of at least 25 g/s and not more than 150 g/s.
2.7.7.2.3.	For the purpose of testing the requirements of 2.4.5.2.1.3 and 2.4.5.2.1.4, the retractor shall be mounted on a horizontal table and the table tilted at a speed not exceeding 2 ° per second until locking has occurred. The test shall be repeated in other directions so as to ensure that the requirements are fulfilled.
2.7.7.3.	Dust resistance.
2.7.7.3.1.	The retractor shall be placed in a test chamber, as shown in Annex VI. Its relative position shall be the same as that in which it is mounted in the vehicle. The test chamber shall contain a quantity of dust which meets the requirements of 2.7.7.3.2. 500 mm of the strap shall be extracted from the retractor and kept extracted, except that it shall be subjected to 10 complete cycles of retraction and withdrawal within one or two minutes after each agitation of the dust. For a period of five hours, the dust shall be agitated every 20 minutes for five seconds by compressed air which is dry and free of lubricating oil, passing through an aperture $1,5 \pm 0,1$ mm in diameter at a gauge pressure of $5,5 \times 10^5 \pm 0,5 \times 10^5$ Pa.
2.7.7.3.2.	The dust used in the test described in 2.7.7.3.1 shall consist of about 1 kg of dry quartz. The particle size distribution shall be as follows:
<b>a</b>	Vehicle categories defined in Annex IIA to Directive 70/156/EEC.
<b>b</b>	OJ L 38, 11.2.1974, p. 2.
<b>c</b>	OJ L 24, 30.1.1976, p. 6.
<b>d</b>	OJ L 24, 30.1.1976, p. 6.
<b>e</b>	OJ L 165, 20.6.1976, p. 16.
<b>f</b>	In addition to the requirements of 3.1, Member States may, under national law, accept other types of safety belts or restraint systems covered by this Directive for certain vehicle types.
<b>g</b>	OJ L 221, 12.8.1974, p. 1.

*Status: EU Directives are being published on this site to aid cross referencing from UK legislation. After IP completion day (31 December 2020 11pm) no further amendments will be applied to this version.*

	<p>(a) passing through a 150 µm aperture, 104 µm wire diameter: 99 to 100 %;</p> <p>(b) passing through a 105 µm aperture, 64 µm wire diameter: 76 to 86 %;</p> <p>(c) passing through a 75 µm aperture, 52 µm wire diameter: 60 to 70 %.</p>
2.7.7.4.	Retracting force.
2.7.7.4.1.	The retracting force shall be measured with the safety belt assembly fitted to a manikin, as in the dynamic test prescribed in 2.7.8. The strap tension shall be measured as close as possible to the points of contact with (but just clear of) the manikin, while the strap is being retracted at an approximate speed of 0,6 m per minute.
2.7.8.	Dynamic tests of the belt assembly or the restraint system.
2.7.8.1.	The belt assembly shall be mounted on a trolley equipped with the seat and the anchorages defined in Annex VII. If, however, the belt assembly is intended for a specific vehicle or for specific types of vehicle, the distances between the manikin and the anchorages shall be determined by the service conducting the tests, in accordance either with the fitting instructions supplied with the belt, or with the data supplied by the manufacturer of the vehicle. In that case, when the dynamic test has been carried out for a type of vehicle it need not be repeated for other types of vehicle where each anchorage point is less than 50 mm distant from the corresponding anchorage point of the tested belt. Alternatively, manufacturers may determine a hypothetical anchorage position for testing in order to enclose the maximum number of real anchorage points. If the belt is equipped with a belt adjustment device for height such as defined in 1.8.6 above, the position of the
<b>a</b>	Vehicle categories defined in Annex IIA to Directive 70/156/EEC.
<b>b</b>	OJ L 38, 11.2.1974, p. 2.
<b>c</b>	OJ L 24, 30.1.1976, p. 6.
<b>d</b>	OJ L 24, 30.1.1976, p. 6.
<b>e</b>	OJ L 165, 20.6.1976, p. 16.
<b>f</b>	In addition to the requirements of 3.1, Member States may, under national law, accept other types of safety belts or restraint systems covered by this Directive for certain vehicle types.
<b>g</b>	OJ L 221, 12.8.1974, p. 1.

*Status: EU Directives are being published on this site to aid cross referencing from UK legislation. After IP completion day (31 December 2020 11pm) no further amendments will be applied to this version.*

	device and the means of securing it shall be the same as those of the vehicle design.
2.7.8.1.1.	<p>In the case of a safety belt or restraint system with pre-loading devices relying on component parts other than those incorporated in the belt assembly itself, the belt assembly shall be mounted in conjunction with the necessary additional vehicle parts on the test trolley in the manner prescribed in points 2.7.8.1.2 to 2.7.8.1.6. Alternatively, in the case where those devices cannot be tested on the test trolley, the manufacturer may demonstrate by a conventional frontal impact test at 50 km/h in conformity with ISO procedure 3560 (1975/11/1 — Road vehicles — Frontal fixed barrier collision test method) that the device complies with the requirements of the Directive.</p> <p>If a safety belt forms part of an assembly which is the subject of an application for component type-approval as a restraint system, this safety belt must be mounted on that part of the vehicle structure to which it is normally fitted and that part must be attached to the test trolley as follows.</p>
2.7.8.1.2.	<p>The method used to secure the vehicle during the test shall not be such as to strengthen the anchorages of the seats or safety belts, or to lessen the normal deformation of the structure.</p> <p>No forward part of the vehicle shall be present which, by limiting the forward movement of the manikin, apart from the feet, would reduce the load imposed on the restraint system during the test. The discarded parts of the structure can be replaced by parts of equivalent strength, provided that they do not hinder the forward movement of the manikin.</p>
<b>a</b>	Vehicle categories defined in Annex IIA to Directive 70/156/EEC.
<b>b</b>	<a href="#">OJ L 38, 11.2.1974, p. 2.</a>
<b>c</b>	<a href="#">OJ L 24, 30.1.1976, p. 6.</a>
<b>d</b>	<a href="#">OJ L 24, 30.1.1976, p. 6.</a>
<b>e</b>	<a href="#">OJ L 165, 20.6.1976, p. 16.</a>
<b>f</b>	In addition to the requirements of 3.1, Member States may, under national law, accept other types of safety belts or restraint systems covered by this Directive for certain vehicle types.
<b>g</b>	<a href="#">OJ L 221, 12.8.1974, p. 1.</a>

*Status: EU Directives are being published on this site to aid cross referencing from UK legislation. After IP completion day (31 December 2020 11pm) no further amendments will be applied to this version.*

2.7.8.1.3.	A securing device shall be regarded as satisfactory if it produces no effect on an area extending over the whole width of the structure, and if the vehicle or the structure is blocked or immobilised in front at a distance of not less than 500 mm from the anchorage of the restraint system tested. At the rear, the structure shall be secured at a distance behind the anchorages which is sufficient to ensure that the requirements of 2.7.8.1.2 are fulfilled.
2.7.8.1.4.	The seats shall be adjusted and placed in the driving or travelling position considered by the technical service conducting the approval tests as providing the most adverse conditions of strength consistent with the positioning of the manikin in the vehicle. The positions of the seats shall be stated in the report. If the seat back is adjustable, it must be locked as specified by the manufacturer or, in the absence of any specification, locked in such a manner as to form an effective angle as near as possible to 25 ° in the case of vehicles in categories M1 and N1 and as close as possible to 15 ° in the case of vehicles of all other categories.
2.7.8.1.5.	For the purpose of assessing the requirements of 2.6.1.4.1, the seat shall be regarded as being in its most forward driving or travelling position appropriate to the dimensions of the manikin.
2.7.8.1.6.	All seats of the same group shall be tested simultaneously.
2.7.8.2.	The belt assembly must be attached to the manikin described in Annex VIII. A board 25 mm thick must be placed between the back of the manikin and the seat back. The belt must be firmly fastened around the manikin. The board must then be removed and the manikin so positioned that the whole
a	Vehicle categories defined in Annex IIA to Directive 70/156/EEC.
b	OJ L 38, 11.2.1974, p. 2.
c	OJ L 24, 30.1.1976, p. 6.
d	OJ L 24, 30.1.1976, p. 6.
e	OJ L 165, 20.6.1976, p. 16.
f	In addition to the requirements of 3.1, Member States may, under national law, accept other types of safety belts or restraint systems covered by this Directive for certain vehicle types.
g	OJ L 221, 12.8.1974, p. 1.

---

*Status: EU Directives are being published on this site to aid cross referencing from UK legislation. After IP completion day (31 December 2020 11pm) no further amendments will be applied to this version.*

---

	length of its back is in contact with the seat back. A check shall be made to ensure that the mode of engagement of the two parts of the buckle entails no risks of reducing the reliability of locking.
2.7.8.3.	The free ends of the straps shall extend sufficiently far beyond the adjusting devices to allow for slip.
2.7.8.4.	The trolley shall then be propelled in such a way that, at the moment of impact, its free running speed is $50 \pm 1$ km/h and the manikin remains stable. The stopping distance of the trolley shall be $400 \pm 50$ mm. The trolley shall remain horizontal throughout deceleration. Deceleration of the trolley shall be achieved by using the apparatus shown in Annex VII or any other device giving equivalent results. The apparatus shall meet the performance requirements given in Annex IX.
2.7.8.5.	The trolley speed immediately before impact, the forward displacement of the manikin and the speed of the chest at a 300 mm displacement of the chest shall be measured.
2.7.8.6.	After impact, the belt assembly or restraint system and its rigid parts shall be inspected visually, without opening the buckle, in order to determine whether there has been any failure or breakage. In the case of restraint systems, a check shall also be made, after the test, to establish whether the parts of the vehicle structure which are attached to the trolley have undergone any permanent deformation. Any such deformation found shall be taken into account in any calculation made in accordance with 2.6.1.4.1.
2.7.9.	Buckle-opening test.
2.7.9.1.	Belt assemblies which have already undergone the dynamic test in accordance with 2.7.8, shall be used for this test.
<b>a</b>	Vehicle categories defined in Annex IIA to Directive 70/156/EEC.
<b>b</b>	OJ L 38, 11.2.1974, p. 2.
<b>c</b>	OJ L 24, 30.1.1976, p. 6.
<b>d</b>	OJ L 24, 30.1.1976, p. 6.
<b>e</b>	OJ L 165, 20.6.1976, p. 16.
<b>f</b>	In addition to the requirements of 3.1, Member States may, under national law, accept other types of safety belts or restraint systems covered by this Directive for certain vehicle types.
<b>g</b>	OJ L 221, 12.8.1974, p. 1.



*Status: EU Directives are being published on this site to aid cross referencing from UK legislation. After IP completion day (31 December 2020 11pm) no further amendments will be applied to this version.*

2.7.9.2.	The belt assembly must be detached from the test trolley without the buckle being opened. A load shall be applied to the buckle by direct traction via the straps tied to it so that all the straps are subjected to the force of $60/n$ daN; 'n' is the number of straps linked to the buckle when it is in a locked position, its minimum is deemed to be 2. If the buckle is connected to a rigid part, account must be taken, when the force is applied, of the angle formed by the buckle and the rigid part during the dynamic test. At a speed of $400 \pm 20$ mm/min, a load must be applied to the geometric centre of the buckle-release button along a fixed axis running parallel to the initial direction of motion of the button. The buckle must be held in place by a rigid support when the force required to open the buckle is applied. The abovementioned load must not exceed the limit specified in point 2.4.2.5. The point of contact of the test assembly must be spherical, with a radius of $2,5 \pm 0,1$ mm. It must have a smooth metal surface.
2.7.9.3.	The buckle-opening force shall be measured and any failure of the buckle noted.
2.7.9.4.	After the buckle-opening test, the components of the belt assembly or restraint system which have undergone the tests prescribed in 2.7.8 shall be inspected and the extent of the damage sustained by the belt assembly or restraint system in the dynamic test shall be recorded in the test report.
2.7.10.	Additional tests on safety belts with pre-loading devices — Conditioning. The pre-loading device may be separated from the safety belt to be tested and kept for 24 hours at a temperature of $60 \pm 5$ °C. The temperature shall then be raised to $100 \pm 5$ °C for two hours. Subsequently it shall be kept
a	Vehicle categories defined in Annex IIA to Directive 70/156/EEC.
b	OJ L 38, 11.2.1974, p. 2.
c	OJ L 24, 30.1.1976, p. 6.
d	OJ L 24, 30.1.1976, p. 6.
e	OJ L 165, 20.6.1976, p. 16.
f	In addition to the requirements of 3.1, Member States may, under national law, accept other types of safety belts or restraint systems covered by this Directive for certain vehicle types.
g	OJ L 221, 12.8.1974, p. 1.

---

*Status: EU Directives are being published on this site to aid cross referencing from UK legislation. After IP completion day (31 December 2020 11pm) no further amendments will be applied to this version.*

---

	for 24 hours at a temperature of $-30 \pm 5$ °C. After being removed from conditioning, the device shall warm up to ambient temperature. If it has been separated it shall be fitted again to the safety belt.
2.7.11.	<p>Test report.</p> <p>The test report shall record the results of the tests prescribed in 2.7 and, in particular, the trolley speed, the maximum forward displacement of the manikin, the position of the buckle, the buckle-opening force, and any failure or breakage. If, pursuant to 2.7.8.1, the anchorage requirements of Annex VII have not been respected, the report shall describe how the belt assembly or the restraint system is mounted and specify important angles and dimensions. The report, shall also mention any distortion or breakage of the buckle that occurred during the test. In the case of a restraint system, the test report shall also specify the method of attaching the vehicle structure to the trolley, the position of the seats and the tilt of the seat backs. If the forward displacement of the manikin has exceeded the values prescribed in 2.6.1.3, the report shall state whether the requirements of 2.6.1.4.1 have been met.</p>
2.8.	Conformity of production.
2.8.1.	Any safety belt or restraint system approved under this Directive shall be so manufactured as to conform to the type approved by meeting the requirements set forth in 2.3, 2.4, 2.5, 2.6 and 2.7 above.
2.8.2.	In order to verify that the requirements of point 2.8.1 are met, suitable controls of the production shall be carried out.
2.8.3.	As a general rule, measures to ensure the conformity of production shall be taken in accordance with the provisions laid down in Article 10 of Directive 70/156/EEC.
<b>a</b>	Vehicle categories defined in Annex IIA to Directive 70/156/EEC.
<b>b</b>	OJ L 38, 11.2.1974, p. 2.
<b>c</b>	OJ L 24, 30.1.1976, p. 6.
<b>d</b>	OJ L 24, 30.1.1976, p. 6.
<b>e</b>	OJ L 165, 20.6.1976, p. 16.
<b>f</b>	In addition to the requirements of 3.1, Member States may, under national law, accept other types of safety belts or restraint systems covered by this Directive for certain vehicle types.
<b>g</b>	OJ L 221, 12.8.1974, p. 1.

*Status: EU Directives are being published on this site to aid cross referencing from UK legislation. After IP completion day (31 December 2020 11pm) no further amendments will be applied to this version.*

2.8.3.1.	Special provisions detailing the tests to be carried out and the test frequency are laid down in Annex XVI to this Directive or in Annex 16 of the document referred to in Annex XVII, as applicable.
2.9.	Instructions.
2.9.1.	In the case of a safety belt supplied separately from the vehicle, the packaging and installation instructions must clearly state the vehicle type(s) for which it is intended.
2.9.2.	Every child restraint system shall be accompanied by the instructions specified in Annex X.
3.	REQUIREMENTS CONCERNING INSTALLATION IN THE VEHICLE
3.1.	Vehicle equipment <sup>f</sup> .
3.1.1.	With the exception of folding seats (as defined in Directive 76/115/EEC) and seating intended solely for use when the vehicle is stationary, the seats of vehicles covered by Article 9 in categories M and N (except those vehicles in categories M2 and M3 which are designed for both urban use and standing passengers) must be equipped with safety belts or restraint systems which satisfy the requirements of this Directive.
3.1.2.	The types of safety belts or restraint systems for each seating position where installation is required shall be those specified in Annex XV (with which neither non-locking retractors (1.8.1) nor manually unlocking retractors (1.8.2) can be used). For all seating positions where lap belts type B are specified in Annex XV lap belts type Br3 are permitted except in the case that, in use, they retract to such an extent as to reduce comfort in a notable way after normal buckling up.
<b>a</b>	Vehicle categories defined in Annex IIA to Directive 70/156/EEC.
<b>b</b>	OJ L 38, 11.2.1974, p. 2.
<b>c</b>	OJ L 24, 30.1.1976, p. 6.
<b>d</b>	OJ L 24, 30.1.1976, p. 6.
<b>e</b>	OJ L 165, 20.6.1976, p. 16.
<b>f</b>	In addition to the requirements of 3.1, Member States may, under national law, accept other types of safety belts or restraint systems covered by this Directive for certain vehicle types.
<b>g</b>	OJ L 221, 12.8.1974, p. 1.

---

**Status:** EU Directives are being published on this site to aid cross referencing from UK legislation. After IP completion day (31 December 2020 11pm) no further amendments will be applied to this version.

---

3.1.3.	If a vehicle is fitted with an integrated child restraint system it shall comply with the relevant requirements contained in Annex XVII.
3.1.4.	Where no safety belts are required any type of safety belt or restraint system conforming to this Directive may be provided at the choice of the manufacturer. A-type belts of the types permitted in Annex XV may be provided as an alternative to lap belts for those seating positions where lap belts are specified in Annex XV.
3.1.5.	On three point belts fitted with retractors, one retractor must operate at least on the diagonal strap.
3.1.6.	Except for vehicles of category M, an emergency locking retractor of type 4N (1.8.5) may be permitted instead of a retractor of type 4 (1.8.4) where it has been shown to the satisfaction of the services responsible for the tests that the fitting of a type 4 retractor would not be practical.
3.1.7.	For the front outboard and front centre seating positions shown in Annex XV and marked with the symbol *, lap belts of the type specified in that Annex shall be considered adequate where the windscreen is located outside the reference zone defined in Annex II to Directive 74/60/EEC. As regards safety belts, the windscreen is considered as part of the reference zone when it is capable of entering into static contact with the test apparatus according to the method described in Annex II to Directive 74/60/EEC.
3.1.8.	For all seating positions in Annex XV marked with the symbol #, lap belts of the types specified in Annex XV must be provided where an 'exposed seating position' as defined in 3.1.9 exists.
<b>a</b>	Vehicle categories defined in Annex IIA to Directive 70/156/EEC.
<b>b</b>	OJ L 38, 11.2.1974, p. 2.
<b>c</b>	OJ L 24, 30.1.1976, p. 6.
<b>d</b>	OJ L 24, 30.1.1976, p. 6.
<b>e</b>	OJ L 165, 20.6.1976, p. 16.
<b>f</b>	In addition to the requirements of 3.1, Member States may, under national law, accept other types of safety belts or restraint systems covered by this Directive for certain vehicle types.
<b>g</b>	OJ L 221, 12.8.1974, p. 1.

*Status: EU Directives are being published on this site to aid cross referencing from UK legislation. After IP completion day (31 December 2020 11pm) no further amendments will be applied to this version.*

3.1.9.	<p>An ‘exposed seating position’ is one where there is no ‘protective screen’ in front of the seat within the following defined space:</p> <ul style="list-style-type: none"><li>— between two horizontal planes, one through the H-point and the other 400 mm above it,</li><li>— between two vertical longitudinal planes which are symmetrical in relation to the H-point and are 400 mm apart,</li><li>— behind a transverse vertical plane 1,30 m from the H-point.</li></ul> <p>For the purpose of this requirement ‘protective screen’ means a surface of suitable strength and showing no discontinuities such that, if a sphere of 165 mm diameter is geometrically projected in a longitudinal horizontal direction through any point of the space defined above and through the centre of the sphere, nowhere in the protective screen is there any aperture through which the geometrical projection of the sphere could be passed.</p> <p>A seat is considered to be in an ‘exposed seating position’, if the protective screens within the space defined above have a combined surface area of less than 800 cm<sup>2</sup>.</p>
3.1.10.	<p>At every seating position in Annex XV marked with the symbol , three-point belts of a type specified in Annex XV shall be provided unless one of the following conditions is fulfilled:</p> <ul style="list-style-type: none"><li>— there is a seat or other vehicle parts conforming to point 3.5 of Appendix 1 of Annex III to Council Directive 74/408/EEC<sup>a</sup> directly in front, or</li><li>— no part of the vehicle is in or, when the vehicle is in motion, capable of being in the reference zone, or</li></ul>
<b>a</b>	Vehicle categories defined in Annex IIA to Directive 70/156/EEC.
<b>b</b>	OJ L 38, 11.2.1974, p. 2.
<b>c</b>	OJ L 24, 30.1.1976, p. 6.
<b>d</b>	OJ L 24, 30.1.1976, p. 6.
<b>e</b>	OJ L 165, 20.6.1976, p. 16.
<b>f</b>	In addition to the requirements of 3.1, Member States may, under national law, accept other types of safety belts or restraint systems covered by this Directive for certain vehicle types.
<b>g</b>	OJ L 221, 12.8.1974, p. 1.

---

*Status: EU Directives are being published on this site to aid cross referencing from UK legislation. After IP completion day (31 December 2020 11pm) no further amendments will be applied to this version.*

---

	— parts of the vehicle within the said reference zone comply with the energy absorbing requirements set out in Appendix 6 of Annex III to Directive 74/408/EEC, in which case two-point belts of a type specified in Annex XV may be provided.
3.1.11.	Save as provided by point 3.1.12 every passenger seating position which is fitted with an air bag shall be provided with a warning against the use of a rearward-facing child restraint on that seat. The warning label, in the form of a pictogram which may include explanatory text, shall be durably affixed and located such that it is easily visible in front of a person about to install a rearward-facing child restraint on the seat in question. An example of a possible design of pictogram is shown in Figure 1. A permanent reference should be visible at all times, in case the warning is not visible when the door is closed.
3.1.12.	The requirements of point 3.1.11 shall not apply if the vehicle is fitted with a mechanism which senses automatically the presence of a rearward-facing child restraint, and ensures that the air bag will not be deployed when such a child restraint system is fitted.
3.1.13.	In the case of seats capable of being turned to or placed in other orientations, for use when the vehicle is stationary, the requirements of point 3.1.1 shall only apply to those orientations designated for normal use when the vehicle is travelling on a road, in accordance with this Directive. A note to this effect shall be included in the information document.
3.2.	General requirements.
a	Vehicle categories defined in Annex IIA to Directive 70/156/EEC.
b	OJ L 38, 11.2.1974, p. 2.
c	OJ L 24, 30.1.1976, p. 6.
d	OJ L 24, 30.1.1976, p. 6.
e	OJ L 165, 20.6.1976, p. 16.
f	In addition to the requirements of 3.1, Member States may, under national law, accept other types of safety belts or restraint systems covered by this Directive for certain vehicle types.
g	OJ L 221, 12.8.1974, p. 1.

*Status: EU Directives are being published on this site to aid cross referencing from UK legislation. After IP completion day (31 December 2020 11pm) no further amendments will be applied to this version.*

3.2.1.	Safety belts and restraint systems shall be fixed to anchorages conforming to the specifications of Directive 76/115/EEC.
3.2.2.	The safety belts and the restraint systems shall be so installed that, when properly worn, they will work satisfactorily and reduce the risk of bodily injury in the event of an accident. In particular they shall be so installed that:
3.2.2.1.	the straps are not liable to assume a dangerous configuration;
3.2.2.2.	that the danger of a correctly positioned belt slipping from the shoulder of a wearer as a result of his/her forward movement is reduced to a minimum;
3.2.2.3.	the risk of the strap deteriorating through contact with sharp rigid parts of the vehicle or seat structure is reduced to a minimum.
3.2.2.4.	The design and installation of every safety belt provided for each seating position shall be such as to be readily available for use. Furthermore, where the complete seat or the seat cushion and/or the seat back can be folded to permit access to the rear of the vehicle or to carry goods or luggage, after folding and restoring those seats to the seating position, the safety belts provided for those seats shall be accessible for use or be easily recovered from under or behind the seat by one person, according to instructions in the vehicle users handbook, without the need for that person to have training or practice.
3.2.2.5.	The technical service shall verify that, with the buckle tongue engaged in the buckle and no occupant in the seat: — the possible slack in the belt does not prevent the correct installation of child restraint
<b>a</b>	Vehicle categories defined in Annex IIA to Directive 70/156/EEC.
<b>b</b>	OJ L 38, 11.2.1974, p. 2.
<b>c</b>	OJ L 24, 30.1.1976, p. 6.
<b>d</b>	OJ L 24, 30.1.1976, p. 6.
<b>e</b>	OJ L 165, 20.6.1976, p. 16.
<b>f</b>	In addition to the requirements of 3.1, Member States may, under national law, accept other types of safety belts or restraint systems covered by this Directive for certain vehicle types.
<b>g</b>	OJ L 221, 12.8.1974, p. 1.

---

*Status: EU Directives are being published on this site to aid cross referencing from UK legislation. After IP completion day (31 December 2020 11pm) no further amendments will be applied to this version.*

---

	<p>— systems recommended by the manufacturer, and</p> <p>— in the case of three-point belts, a tension of at least 50 N can be established in the lap section of the belt by external application of tension in the diagonal section of the belt.</p>
3.3.	Special requirements for rigid parts incorporated in safety belts or restraint systems.
3.3.1.	Rigid parts, such as the buckles, adjusting devices and attachments, shall not increase the risk of bodily injury to the wearer or to other occupants of the vehicle in the event of an accident.
3.3.2.	<p>The device for releasing the buckle shall be clearly visible to and within easy reach of the wearer and shall be so designed that it cannot be opened inadvertently or accidentally. The buckle shall also be located in such a position that it is readily accessible to a rescuer needing to release the wearer in an emergency.</p> <p>The buckle shall be so installed that, both when not under load and when sustaining the wearer's weight, it is capable of being released by the wearer with a single simple movement of either hand in one direction. In the case of safety belts or restraint systems for front outboard seating positions, except if these are harness belts, the buckle shall also be capable of being locked in the same manner.</p> <p>A check shall be made to ensure that, if the buckle is in contact with the wearer, the contact surface satisfies the requirements of 2.4.2.1 of this Annex.</p>
3.3.3.	When the belt is being worn, it shall either adjust automatically to fit the wearer or be so designed that the manual adjusting device is
<b>a</b>	Vehicle categories defined in Annex IIA to Directive 70/156/EEC.
<b>b</b>	<a href="#">OJ L 38, 11.2.1974, p. 2.</a>
<b>c</b>	<a href="#">OJ L 24, 30.1.1976, p. 6.</a>
<b>d</b>	<a href="#">OJ L 24, 30.1.1976, p. 6.</a>
<b>e</b>	<a href="#">OJ L 165, 20.6.1976, p. 16.</a>
<b>f</b>	In addition to the requirements of 3.1, Member States may, under national law, accept other types of safety belts or restraint systems covered by this Directive for certain vehicle types.
<b>g</b>	<a href="#">OJ L 221, 12.8.1974, p. 1.</a>



*Status: EU Directives are being published on this site to aid cross referencing from UK legislation. After IP completion day (31 December 2020 11pm) no further amendments will be applied to this version.*

	readily accessible to the wearer when seated and is convenient and easy to use. It shall also be possible for it to be tightened with one hand to suit the build of the wearer and the position of the vehicle seat.
3.3.4.	Safety belts or restraint systems incorporating retractors shall be so installed that the retractors are able to operate correctly and stow the strap efficiently.
3.4.	In order to inform the vehicle user(s) of the provision made for the transport of children, the requirements of Annex XVIII shall be met.
4.	APPLICATION FOR EC TYPE-APPROVAL FOR A VEHICLE TYPE IN RESPECT OF THE INSTALLATION OF ITS SAFETY BELTS AND RESTRAINT SYSTEMS
4.1.	The application for approval pursuant to Article 3(4) of Directive 70/156/EEC of a vehicle type with regard to the installation of its safety belts and restraint systems shall be submitted by the vehicle manufacturer.
4.2.	A model for the information document is given in Annex II, Appendix 2.
4.3.	A representative vehicle of the type to be approved shall be submitted to the technical service conducting the type-approval tests.
5.	GRANTING OF EC TYPE-APPROVAL
5.1.	If the relevant requirements are satisfied, EC type-approval pursuant to Article 4(3) and, if applicable, 4(4) of Directive 70/156/EEC shall be granted.
5.2.	A model for the EC type-approval certificate is given in:
5.2.1.	Annex II, Appendix 3 for applications referred to in 2.1;
a	Vehicle categories defined in Annex IIA to Directive 70/156/EEC.
b	<a href="#">OJ L 38, 11.2.1974, p. 2.</a>
c	<a href="#">OJ L 24, 30.1.1976, p. 6.</a>
d	<a href="#">OJ L 24, 30.1.1976, p. 6.</a>
e	<a href="#">OJ L 165, 20.6.1976, p. 16.</a>
f	In addition to the requirements of 3.1, Member States may, under national law, accept other types of safety belts or restraint systems covered by this Directive for certain vehicle types.
g	<a href="#">OJ L 221, 12.8.1974, p. 1.</a>

*Status: EU Directives are being published on this site to aid cross referencing from UK legislation. After IP completion day (31 December 2020 11pm) no further amendments will be applied to this version.*

5.2.2.	Annex II, Appendix 4 for applications referred to in 4.
5.3.	An approval number in accordance with Annex VII to Directive 70/156/EEC shall be assigned to each type of safety belt or restraint system and to each type of vehicle approved. The same Member State shall not assign the same number to another type of safety belt or restraint system or to another type of vehicle.
6.	MODIFICATION OF THE TYPE AND AMENDMENTS TO APPROVALS
6.1.	<p>In the case of modifications to either the type of vehicle or of the safety belt or restraint system approved pursuant to this Directive, the provisions of Article 5 of Directive 70/156/EEC shall apply.</p> 
a	Vehicle categories defined in Annex IIA to Directive 70/156/EEC.
b	<a href="#">OJ L 38, 11.2.1974, p. 2.</a>
c	<a href="#">OJ L 24, 30.1.1976, p. 6.</a>
d	<a href="#">OJ L 24, 30.1.1976, p. 6.</a>
e	<a href="#">OJ L 165, 20.6.1976, p. 16.</a>
f	In addition to the requirements of 3.1, Member States may, under national law, accept other types of safety belts or restraint systems covered by this Directive for certain vehicle types.
g	<a href="#">OJ L 221, 12.8.1974, p. 1.</a>

**Editorial Information**

X1 Substituted by [Corrigendum to Commission Directive 2000/3/EC of 22 February 2000](#) adapting to technical progress Council Directive 77/541/EEC relating to safety belts and restraint systems of motor vehicles (Official Journal of the European Communities L 53 of 25 February 2000).

ANNEX II

TYPE-APPROVAL DOCUMENTATION

Appendix 1

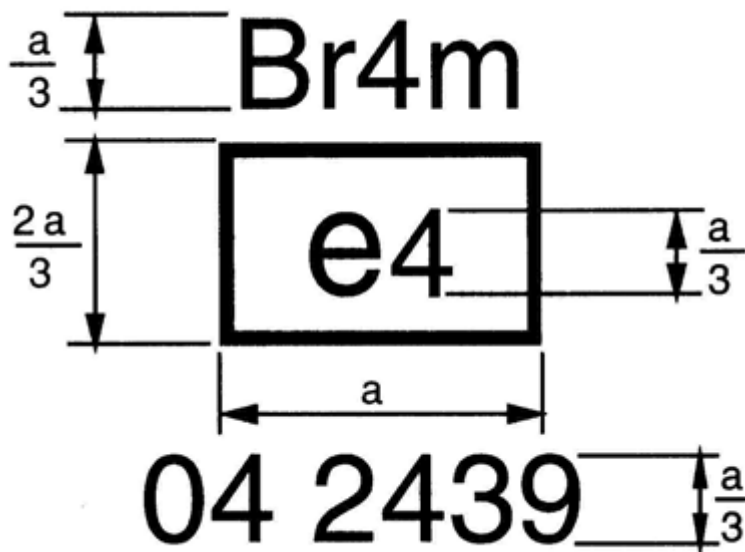
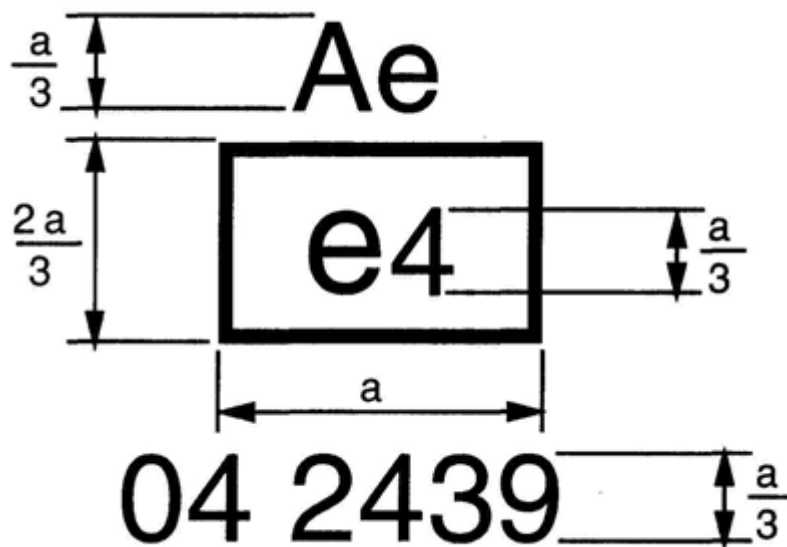

Appendix 2

Status: EU Directives are being published on this site to aid cross referencing from UK legislation. After IP completion day (31 December 2020 11pm) no further amendments will be applied to this version.

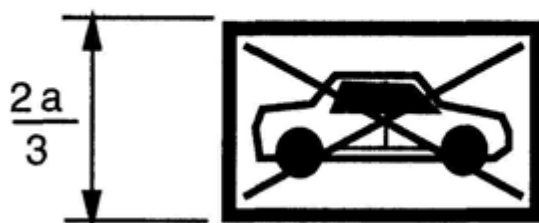
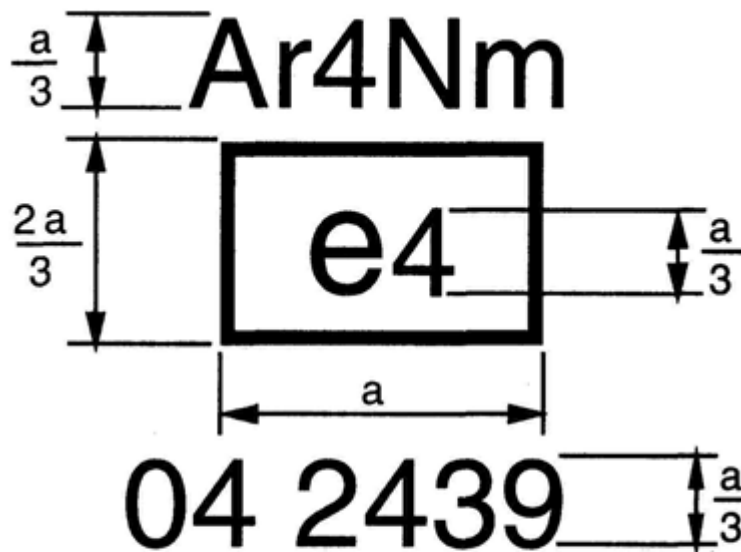
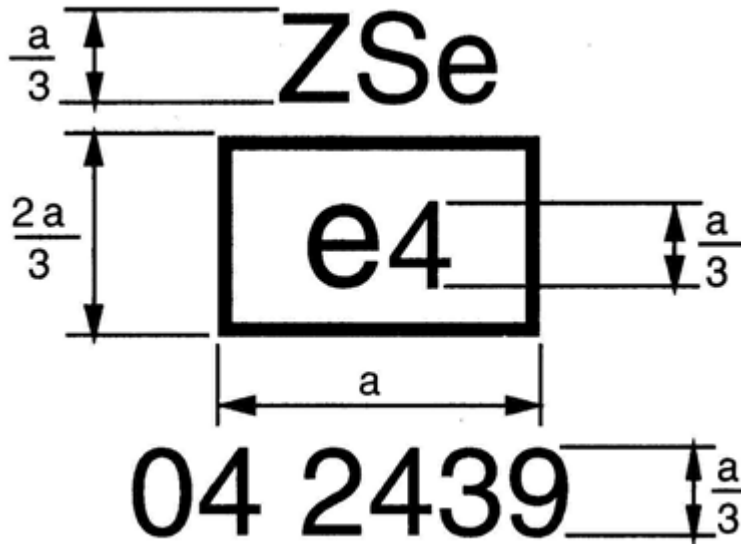

Appendix 3MODEL[maximum format: A4 (210 × 297 mm)]

*Status: EU Directives are being published on this site to aid cross referencing from UK legislation. After IP completion day (31 December 2020 11pm) no further amendments will be applied to this version.*

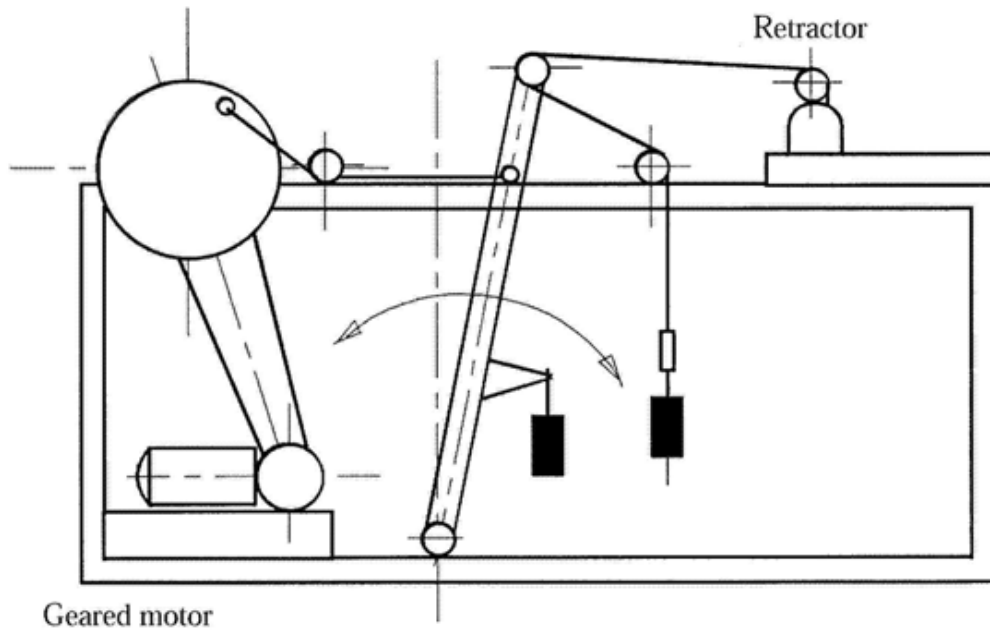
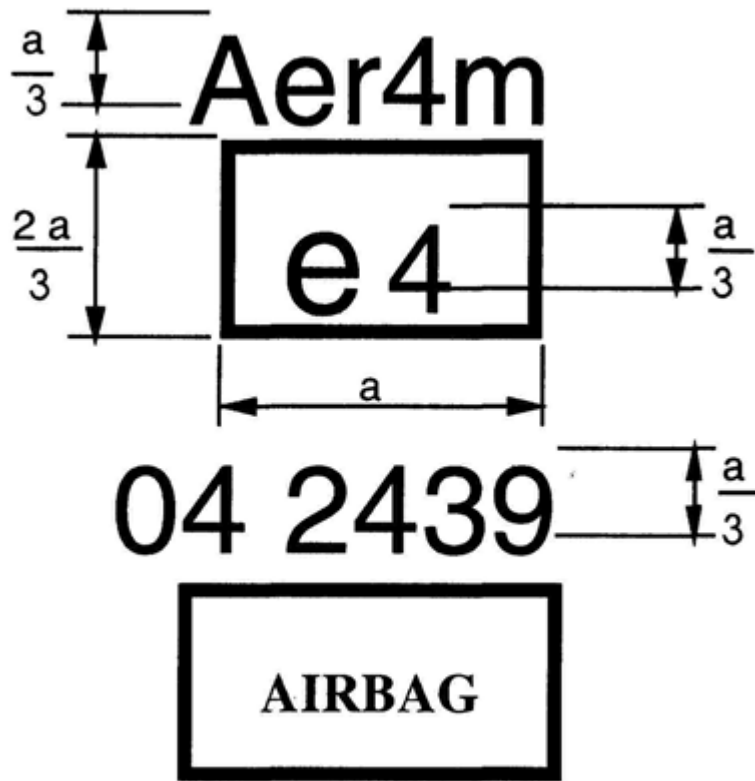

Addendum

---

*Status: EU Directives are being published on this site to aid cross referencing from UK legislation. After IP completion day (31 December 2020 11pm) no further amendments will be applied to this version.*

---

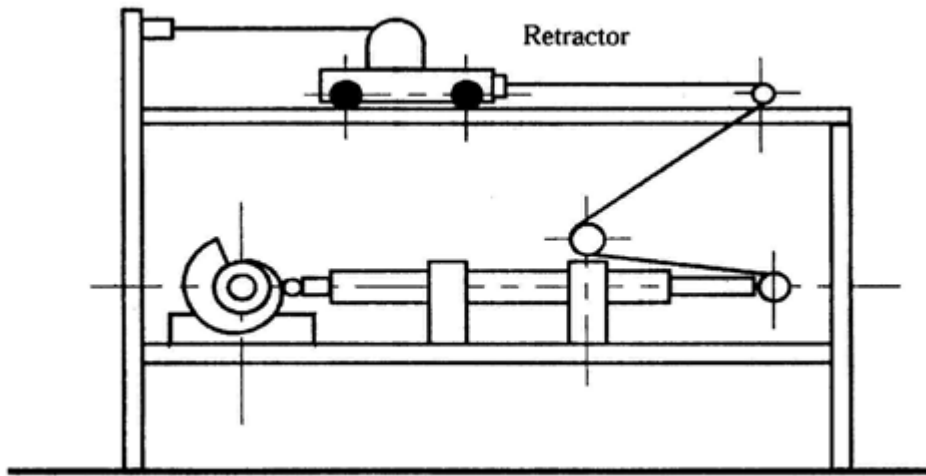

Appendix 4MODEL(maximum format: A4 (210 × 297 mm))

*Status: EU Directives are being published on this site to aid cross referencing from UK legislation. After IP completion day (31 December 2020 11pm) no further amendments will be applied to this version.*

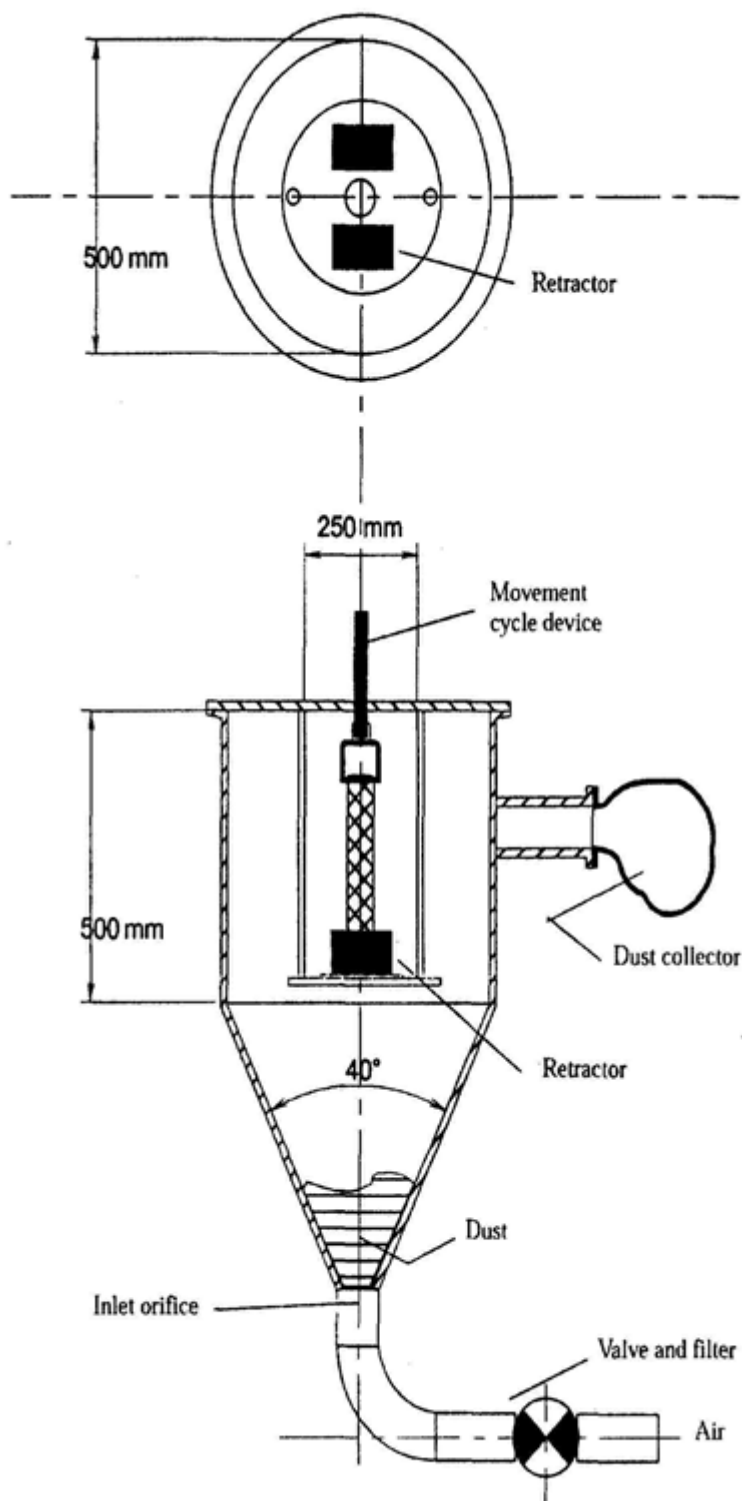

*Status: EU Directives are being published on this site to aid cross referencing from UK legislation. After IP completion day (31 December 2020 11pm) no further amendments will be applied to this version.*

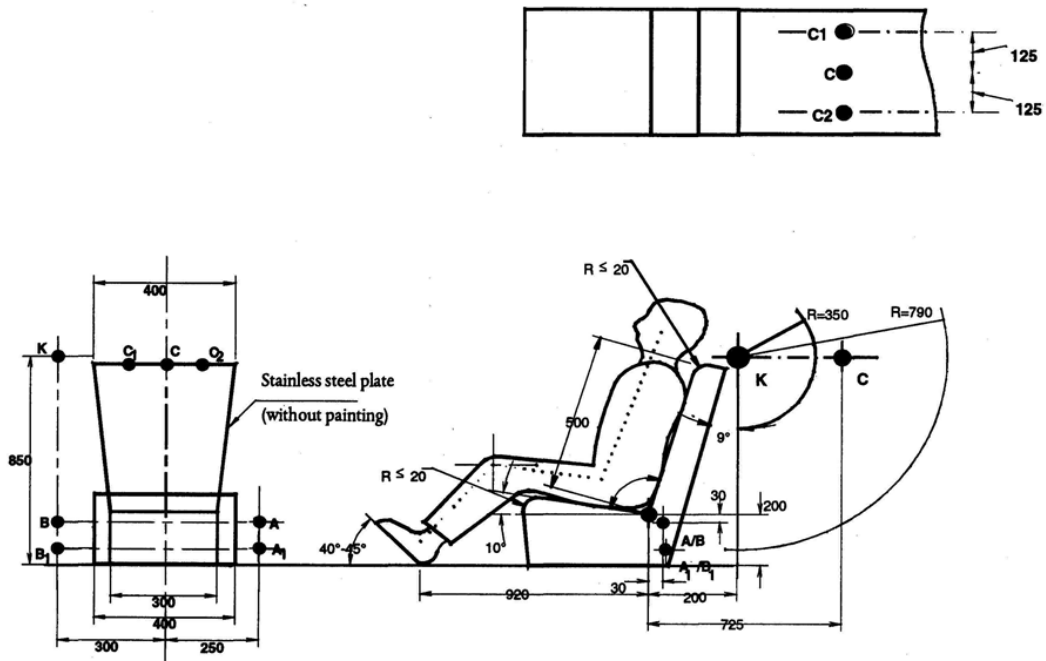

Addendum



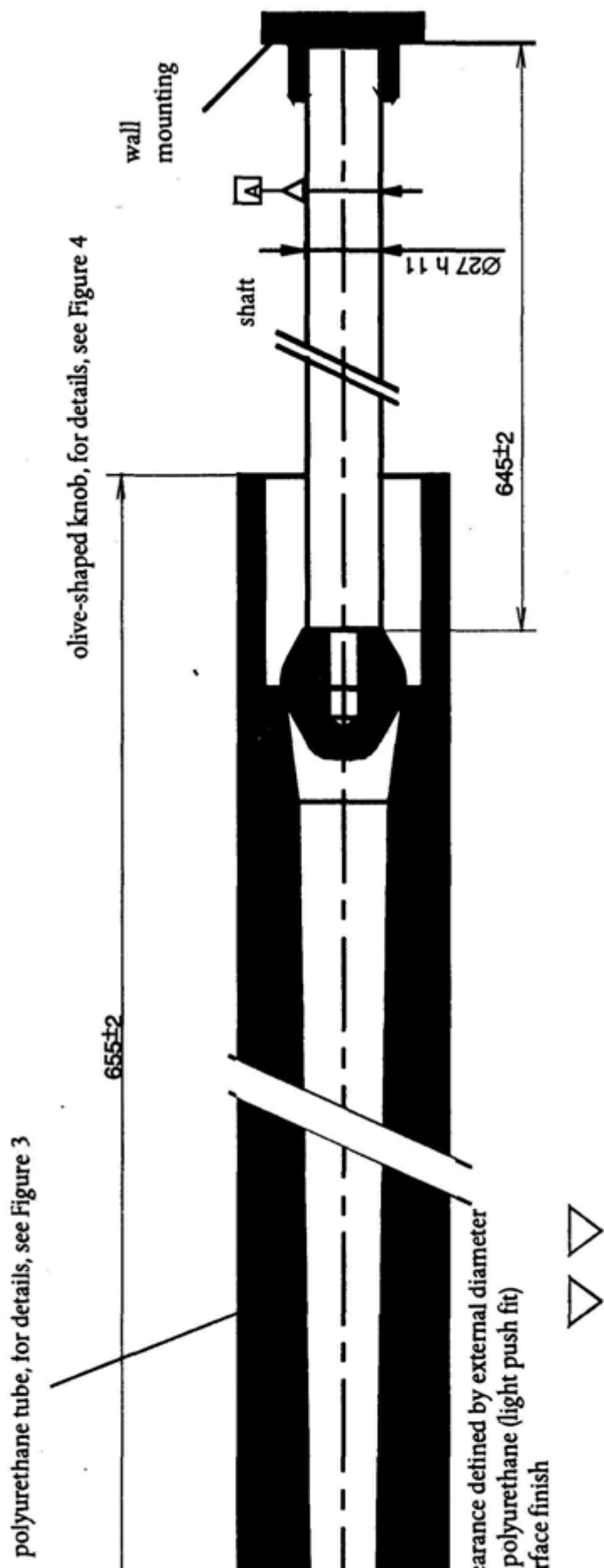

*Status: EU Directives are being published on this site to aid cross referencing from UK legislation. After IP completion day (31 December 2020 11pm) no further amendments will be applied to this version.*

## ANNEX III

## EC COMPONENT TYPE-APPROVAL MARK

1.1.	Every safety belt or restraint system conforming to a type approved under this Directive shall bear an EC component type-approval mark. The EC component type-approval mark shall consist of:																																																		
1.1.1.	<p>a rectangle surrounding the lower-case letter 'e' followed by the distinguishing letter(s) or number of the Member State which has granted the EC component type-approval:</p> <table data-bbox="801 831 1230 1653"> <tr><td>1</td><td>for Germany,</td></tr> <tr><td>2</td><td>for France,</td></tr> <tr><td>3</td><td>for Italy,</td></tr> <tr><td>4</td><td>for the Netherlands,</td></tr> <tr><td>5</td><td>for Sweden,</td></tr> <tr><td>6</td><td>for Belgium,</td></tr> <tr><td>[<sup>F5</sup>7</td><td>for Hungary,</td></tr> <tr><td>8</td><td>for the Czech Republic,]</td></tr> <tr><td>9</td><td>for Spain,</td></tr> <tr><td>11</td><td>for the United Kingdom,</td></tr> <tr><td>12</td><td>for Austria,</td></tr> <tr><td>13</td><td>for Luxembourg,</td></tr> <tr><td>17</td><td>for Finland,</td></tr> <tr><td>18</td><td>for Denmark,</td></tr> <tr><td>[<sup>F5</sup>20</td><td>for Poland,]</td></tr> <tr><td>21</td><td>for Portugal,</td></tr> <tr><td>23</td><td>for Greece,</td></tr> <tr><td>[<sup>F5</sup>26</td><td>for Slovenia,</td></tr> <tr><td>27</td><td>for Slovakia,</td></tr> <tr><td>29</td><td>for Estonia,</td></tr> <tr><td>32</td><td>for Latvia,</td></tr> <tr><td>36</td><td>for Lithuania,</td></tr> <tr><td>CY</td><td>for Cyprus,]</td></tr> <tr><td>IRL</td><td>for Ireland[<sup>F6</sup>,]</td></tr> <tr><td>[<sup>F5</sup>MT</td><td>for Malta.]</td></tr> </table>	1	for Germany,	2	for France,	3	for Italy,	4	for the Netherlands,	5	for Sweden,	6	for Belgium,	[ <sup>F5</sup> 7	for Hungary,	8	for the Czech Republic,]	9	for Spain,	11	for the United Kingdom,	12	for Austria,	13	for Luxembourg,	17	for Finland,	18	for Denmark,	[ <sup>F5</sup> 20	for Poland,]	21	for Portugal,	23	for Greece,	[ <sup>F5</sup> 26	for Slovenia,	27	for Slovakia,	29	for Estonia,	32	for Latvia,	36	for Lithuania,	CY	for Cyprus,]	IRL	for Ireland[ <sup>F6</sup> ,]	[ <sup>F5</sup> MT	for Malta.]
1	for Germany,																																																		
2	for France,																																																		
3	for Italy,																																																		
4	for the Netherlands,																																																		
5	for Sweden,																																																		
6	for Belgium,																																																		
[ <sup>F5</sup> 7	for Hungary,																																																		
8	for the Czech Republic,]																																																		
9	for Spain,																																																		
11	for the United Kingdom,																																																		
12	for Austria,																																																		
13	for Luxembourg,																																																		
17	for Finland,																																																		
18	for Denmark,																																																		
[ <sup>F5</sup> 20	for Poland,]																																																		
21	for Portugal,																																																		
23	for Greece,																																																		
[ <sup>F5</sup> 26	for Slovenia,																																																		
27	for Slovakia,																																																		
29	for Estonia,																																																		
32	for Latvia,																																																		
36	for Lithuania,																																																		
CY	for Cyprus,]																																																		
IRL	for Ireland[ <sup>F6</sup> ,]																																																		
[ <sup>F5</sup> MT	for Malta.]																																																		
1.1.2.	In the vicinity of the rectangle the 'base approval number' contained in Section 4 of the type-approval number referred to in Annex VII of Directive 70/156/EEC preceded by the two figures indicating the sequence number assigned to the latest major technical amendment to Directive 77/541/EEC on the date EC component type-approval was granted. In this Directive the sequence number is 04 for adult safety																																																		

	belts and restraint systems and 03 for child restraint systems.
1.1.3.	The following additional symbol or symbols located above the rectangle.
1.1.3.1.	The letter 'A' in the case of a three-point belt, the letter 'B' in the case of a lap belt and the letter 'S' in the case of a special type belt.
1.1.3.2.	The symbols described in 1.1.3.1 shall be supplemented by the following marks.
1.1.3.2.1.	The letter 'e' in the case of a belt fitted with an energy absorber.
1.1.3.2.2.	The letter 'r' in the case of a safety belt fitted with a retractor, followed by the number of the type of retractor used, in accordance with 1.8 of Annex I, and the letter 'm' if the retractor used is an emergency locking retractor with multiple sensitivity.
1.1.3.2.3.	The letter 'p' in the case of a safety belt with a pre-loading device.
1.1.3.3.	The symbols described in 1.1.3.1 shall be preceded by the letter 'Z' when the safety belt is part of a restraint system.
1.1.4.	Belts fitted with a type 4N retractor shall also bear a symbol consisting of a rectangle with a vehicle of category M1 crossed out, indicating that the use of this type of retractor is prohibited in vehicles of that category.
1.1.5.	If the safety-belt is approved following the provisions of the paragraph 2.6.1.3.3. of Annex I to this Directive, it shall be marked with the word 'AIRBAG' in a rectangle.
1.1.6.	In the case of child restraints the following additional text located above the rectangle:
1.1.6.1.	the word(s) 'universal', 'restricted', 'semi-universal' or 'vehicle specific' depending on the category of restraint,
1.1.6.2.	the mass range for which the child restraint has been designed, namely: less than 10 kg; less than 13 kg; 9 to 18 kg; 15 to 25 kg; 22 to 36 kg; less than 18 kg; 9 to 25 kg; 15 to 36 kg; less than 25 kg; 9 to 36 kg; less than 36 kg,
1.1.6.3.	the symbol 'Y' in the case of a device containing a crotch strap,

*Status: EU Directives are being published on this site to aid cross referencing from UK legislation. After IP completion day (31 December 2020 11pm) no further amendments will be applied to this version.*

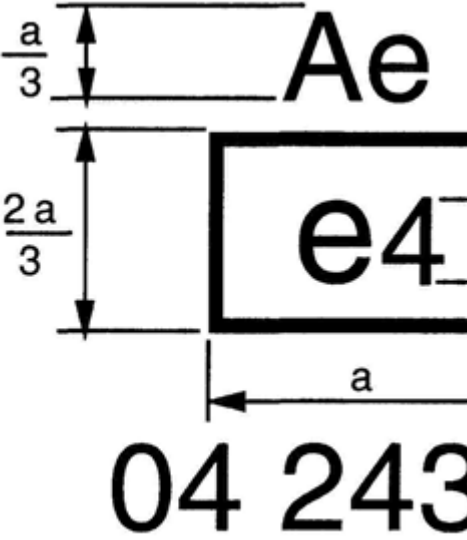
1.1.6.4.	the symbol 'S' in the case of a 'Special needs restraint'.
1.2.	The details described in 1.1 shall be clearly legible and indelible, and must be provided either by means of a label or by direct marking. The label or marking shall be resistant to wear.
2.	DIAGRAMS OF EC COMPONENT TYPE-APPROVAL MARKS
2.1.	 <p>The belt bearing the above EC component type-approval mark is a three-point belt 'A' fitted with an energy absorber (e) and approved in the Netherlands (e 4) according to this Directive (04) under the base approval number 2439.</p>

*Status: EU Directives are being published on this site to aid cross referencing from UK legislation. After IP completion day (31 December 2020 11pm) no further amendments will be applied to this version.*

2.2.

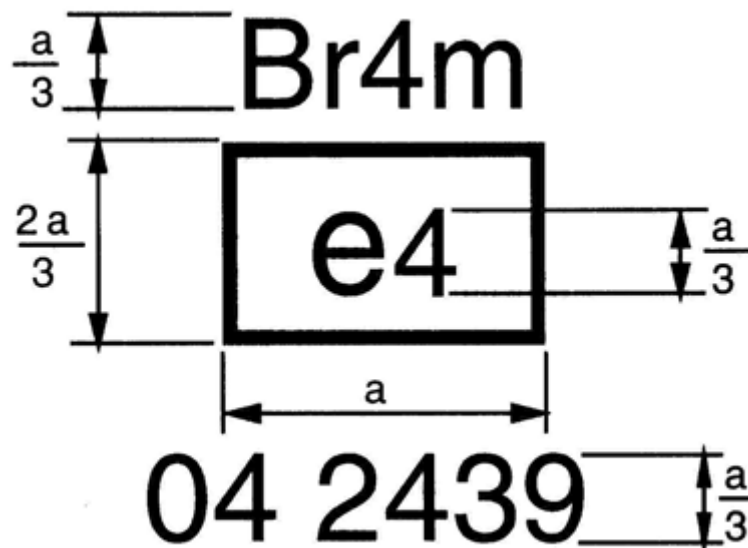

The belt bearing the above EC component type-approval mark is a lap belt 'B' fitted with a type 4 retractor with multiple sensitivity and approved in the Netherlands (e 4) according to this Directive (04) under the base approval number 2439.

2.3.

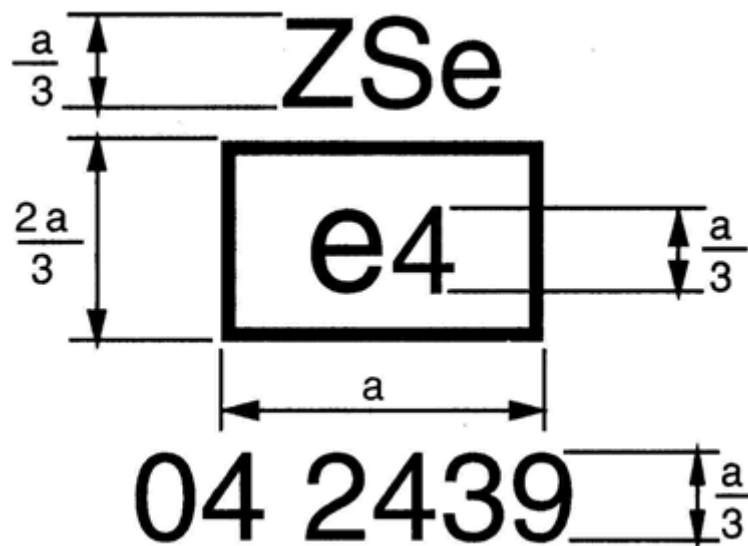

The belt bearing the above EC component type-approval mark is a special type of belt 'S', fitted with an energy absorber (e), forming part of a restraint system 'Z' and approved in the Netherlands (e 4) according

*Status: EU Directives are being published on this site to aid cross referencing from UK legislation. After IP completion day (31 December 2020 11pm) no further amendments will be applied to this version.*

to this Directive (04) under the base approval number 2439.

2.4.

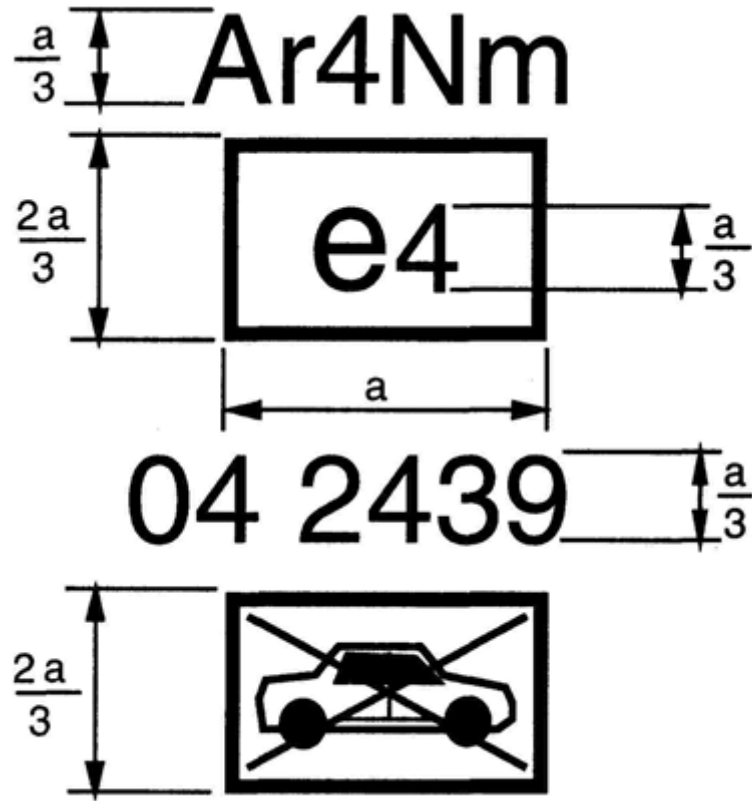

The belt bearing this type-approval mark is a three-point belt 'A' having a multiple-sensitivity 'm' type 4N 'r4N' retractor, in respect of which EC component type-approval was granted in the Netherlands 'e4' according to this Directive (04) under the base approval number 2439. This belt shall not be fitted to vehicles of category M1.  
*Note:* The base approval number and symbol(s) shall be placed close to the rectangle.

2.5.

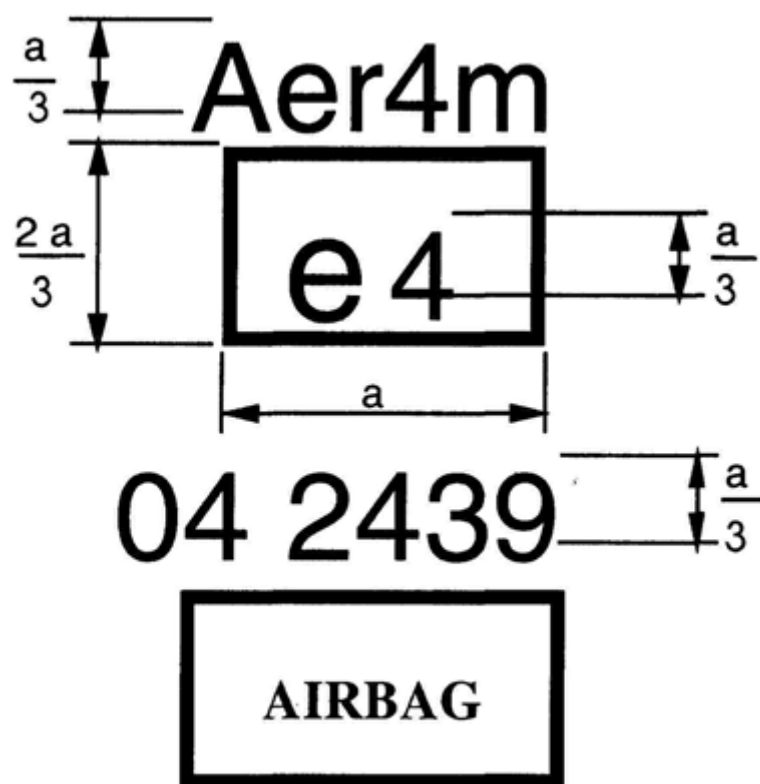

The belt bearing this type-approval mark is a three-point belt 'A' fitted with an energy absorber 'e', approved as meeting the specific requirements of paragraphs 2.6.1.3.3 of Annex I to this Directive, having a multiple-sensitivity 'm' type 4 'r4' retractor, in respect of which EC component type-approval was granted in the Netherlands 'e4' according to this Directive (04) under the approval number 2439. This belt has to be fitted to a vehicle equipped with an airbag in the given seating position.

#### Textual Amendments

- F5** Inserted by Act concerning the conditions of accession of the Czech Republic, the Republic of Estonia, the Republic of Cyprus, the Republic of Latvia, the Republic of Lithuania, the Republic of Hungary, the Republic of Malta, the Republic of Poland, the Republic of Slovenia and the Slovak Republic and the adjustments to the Treaties on which the European Union is founded.
- F6** Substituted by Act concerning the conditions of accession of the Czech Republic, the Republic of Estonia, the Republic of Cyprus, the Republic of Latvia, the Republic of Lithuania, the Republic of Hungary, the Republic of Malta, the Republic of Poland, the Republic of Slovenia and the Slovak Republic and the adjustments to the Treaties on which the European Union is founded.

*Status: EU Directives are being published on this site to aid cross referencing from UK legislation. After IP completion day (31 December 2020 11pm) no further amendments will be applied to this version.*

## ANNEX IV

## EXAMPLE OF AN APPARATUS TO TEST DURABILITY OF RETRACTOR MECHANISM

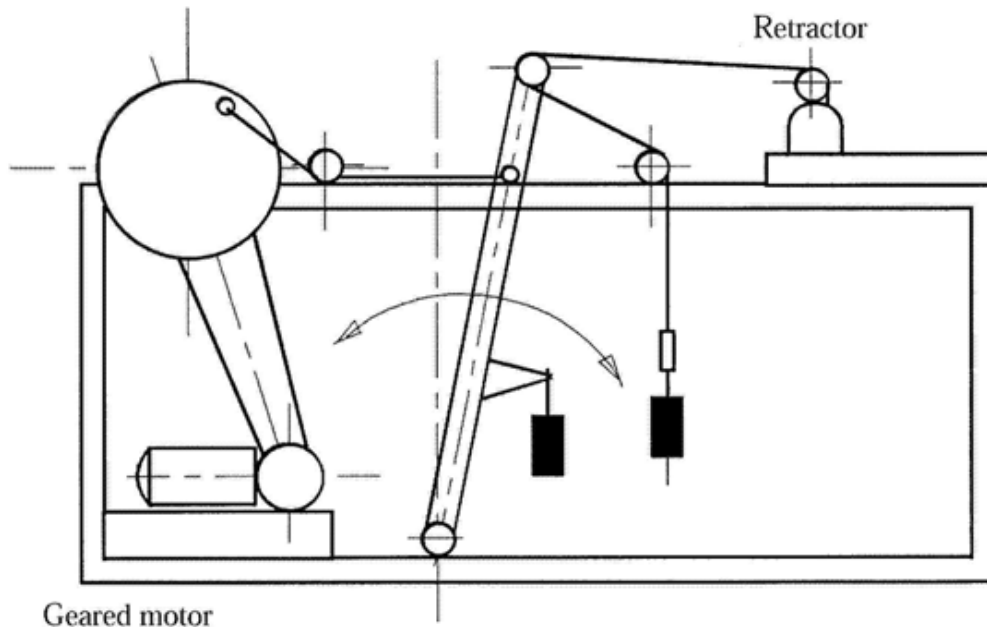

## ANNEX V

## EXAMPLE OF AN APPARATUS TO TEST LOCKING OF EMERGENCY LOCKING RETRACTORS

A suitable apparatus is illustrated in the figure and consists of a motor-driven cam, the follower of which is attached by wires to a small trolley mounted on a track. The cam follower incorporates a 'lost motion' device which absorbs any movement should the reel lock before the full stroke of the follower is completed. The cam design and motor speed combination is such as to give the required acceleration at a rate of increase of acceleration as specified in 2.7.7.2.2 of Annex 1, and the stroke is arranged to be in excess of the maximum permitted strap movement before locking.

On the trolley a carrier is mounted which can be swivelled to enable the retractor to be mounted in varying positions relative to the direction of movement of the trolley.

When testing retractors for sensitivity to strap movement, the retractor is mounted on a suitable fixed bracket and the strap is attached to the trolley.

When carrying out the above tests any brackets, etc. supplied by the manufacturer or by his representative shall be incorporated in the test installation to simulate as closely as possible the intended installation in a vehicle.

Any additional brackets, etc., that may be required to simulate the installation as intended in a vehicle shall be provided by the manufacturer or by his representative.



---

**Status:** EU Directives are being published on this site to aid cross referencing from UK legislation. After IP completion day (31 December 2020 11pm) no further amendments will be applied to this version.

---

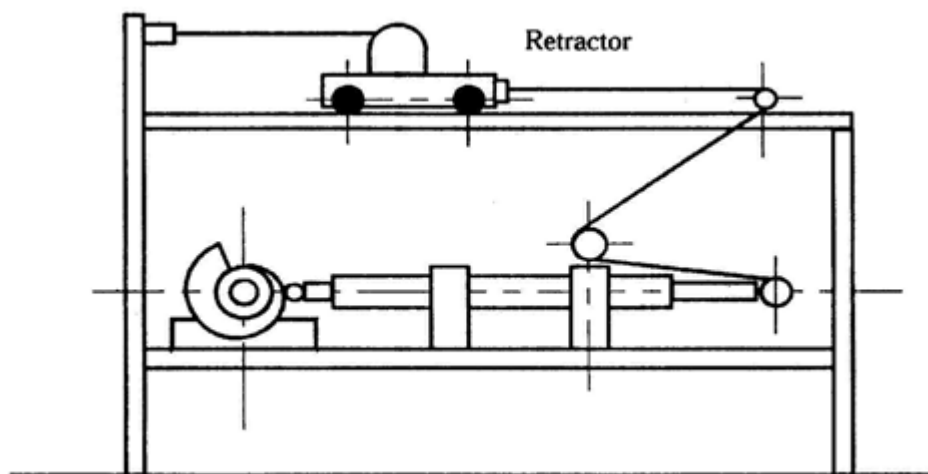

Status: EU Directives are being published on this site to aid cross referencing from UK legislation. After IP completion day (31 December 2020 11pm) no further amendments will be applied to this version.

## ANNEX VI

## EXAMPLE OF AN APPARATUS TO TEST THE DUST RESISTANCE OF RETRACTORS

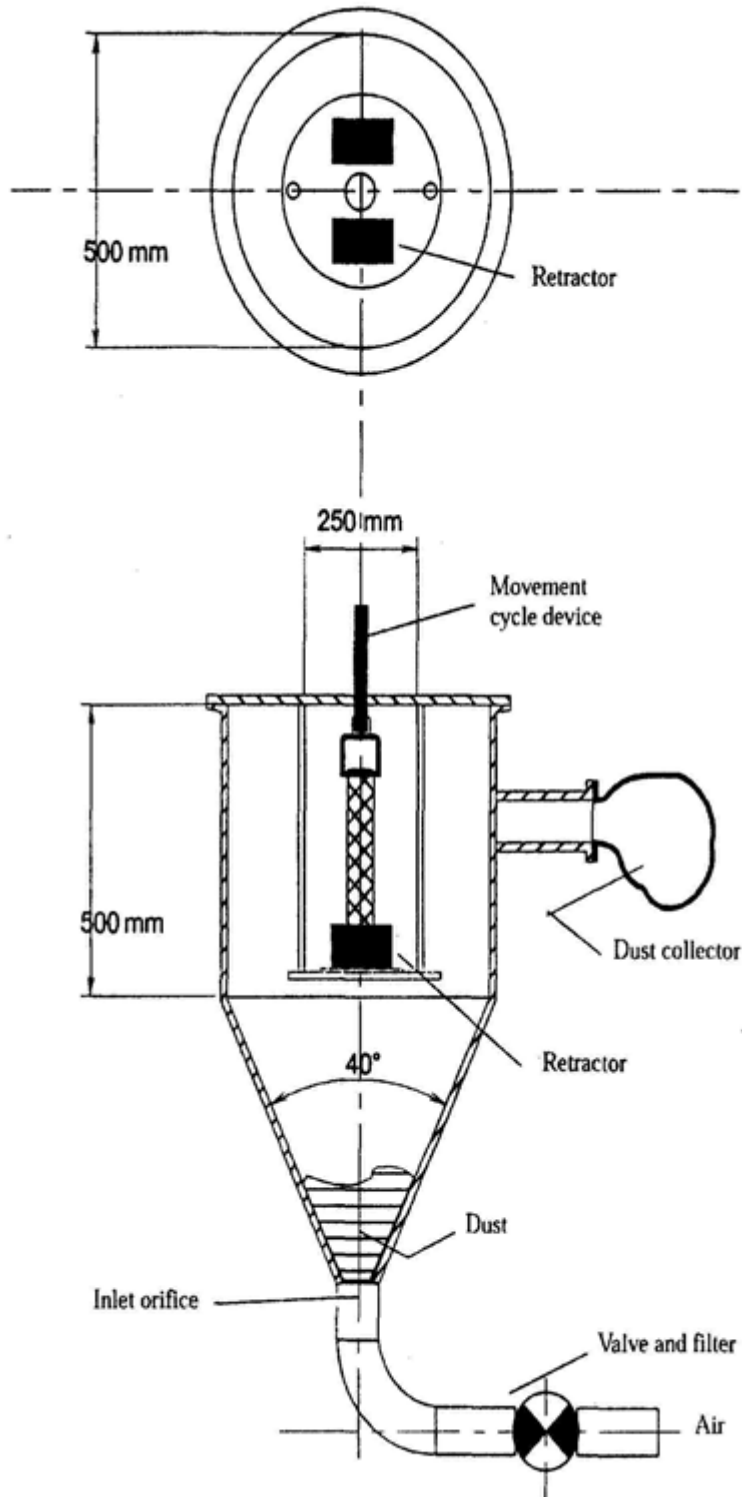

## ANNEX VII

## DESCRIPTION OF TROLLEY, SEAT, ANCHORAGES AND STOPPING DEVICE

1.	<p><b>TROLLEY</b></p> <p>For tests on safety belts the trolley, carrying the seat only, shall have a mass of <math>400 \pm 20</math> kg. For tests on restraint systems the trolley, with the vehicle structure attached, shall have a mass of 800 kg. However, if necessary, the total mass of the trolley and vehicle structure may be increased by increments of 200 kg. In no case shall the total mass differ from the nominal value by more than <math>\pm 40</math> kg.</p>
2.	<p><b>SEAT</b></p> <p>Except in the case of tests on restraint systems, the seat shall be of rigid construction and present a smooth surface. The particulars given in Figure 1 hereto shall be respected, care being taken that no metal part can come into contact with the belt.</p>
3.	<p><b>ANCHORAGES</b></p> <p>The anchorages shall be positioned as shown in Figure 1. The circular marks which correspond to the arrangement of the anchorages, show where the ends of the belt are to be connected to the trolley or to the load transducer, as the case may be. The anchorages for normal use are the points A, B and K if the strap length between the upper edge of the buckle and the hole for the attachment of the strap support is not more than 250 mm. Otherwise, the points A<sub>1</sub> and B<sub>1</sub> shall be used. The structure carrying the anchorages shall be rigid. The upper anchorage must not be displaced by more than 0,2 mm in the longitudinal direction when a load of 98 daN is applied to it in that direction. The trolley shall be so constructed that no permanent deformation shall occur in the parts bearing the anchorages during the test.</p> <p>The tolerance on the position of the anchorage points is such that each anchorage point shall be situated at most at 50 mm from corresponding points A, B and K indicated in Figure 1, or A<sub>1</sub>, B<sub>1</sub> and K, as the case may be.</p> <p>If a fourth anchorage is necessary in order to attach the retractor, this anchorage:</p>

---

*Status: EU Directives are being published on this site to aid cross referencing from UK legislation. After IP completion day (31 December 2020 11pm) no further amendments will be applied to this version.*

---

	<ul style="list-style-type: none"> <li>— shall be located in the vertical longitudinal plane passing through K,</li> <li>— shall enable the retractor to be tilted to the angle prescribed by the manufacturer,</li> <li>— shall be located on the arc of a circle with centre K and with radius <math>KB1 = 790</math> mm if the length between the upper strap guide and the strap outlet at the retractor is not less than 540 mm or, in all other cases, on the arc of a circle with centre K and radius 350 mm.</li> </ul>
3.1.	In the case of a belt equipped with a belt adjustment device for height as defined in 1.8.6 of this Directive, this shall be secured either to a rigid frame, or to a part of the vehicle on which it is normally mounted which shall be securely fixed on the test trolley.
4.	<p><b>STOPPING DEVICE</b></p> <p>This device consists of two identical absorbers mounted in parallel, except in the case of restraint systems when four absorbers shall be used for a nominal mass of 800 kg. If necessary, an additional absorber shall be used for each 200 kg increase of nominal mass.</p> <p>Each absorber comprises:</p> <ul style="list-style-type: none"> <li>— an outer casing formed from a steel tube,</li> <li>— a polyurethane energy-absorber tube,</li> <li>— a polished-steel olive-shaped knob penetrating into the absorber,</li> <li>— a shaft and an impact plate.</li> </ul> <p>The dimensions of the various parts of this energy absorber are shown in Figures 2, 3 and 4. The characteristic values of the energy-absorbing material are given below. Immediately before each test, the tubes must be conditioned at a temperature of between 15 and 25 °C for at least 12 hours without being used. The temperature of the stopping device during the dynamic testing of safety belts and restraint systems must be the same as during the calibration test to within <math>\pm 2</math> °C. The requirements relating to the stopping device are set out in Annex IX. Any other device giving equivalent results is acceptable.</p>

**Status:** EU Directives are being published on this site to aid cross referencing from UK legislation. After IP completion day (31 December 2020 11pm) no further amendments will be applied to this version.

### CHARACTERISTIC VALUES OF THE ENERGY-ABSORBING MATERIAL

(ASTM method D 735 unless otherwise stated)

Shore hardness A:		$95 \pm 2$ at $20 \pm 5$ °C
Breaking strength:		$R_o \geq 343$ daN/cm <sup>2</sup>
Minimum elongation:		$A_o \geq 400$ %
Modulus:		at 100 % elongation: $\geq 108$ daN/cm <sup>2</sup>
		at 300 % elongation: $\geq 235$ daN/cm <sup>2</sup>
Low-temperature brittleness (ASTM method D 736):		five hours at -55 °C
Compression set (method B):		22 hours at 70 °C $\leq 45$ %
Density at 25 °C		1,05 to 1,10
Ageing in air (ASTM method D 573):		
70 hours at 100 °C	— shore hardness A:	maximum variation $\pm 3$
	— breaking strength:	decrease $< 10$ % of $R_o$
	— elongation:	decrease $< 10$ % of $A_o$
	— mass:	decrease $< 1$ %
Immersion in oil (ASTM method No 1 Oil):		
70 hours at 100 °C	— shore hardness A:	maximum variation $\pm 4$
	— breaking strength:	decrease $< 15$ % of $R_o$
	— elongation:	decrease $< 10$ % of $A_o$
	— volume:	swelling $< 5$ %
Immersion in oil (ASTM method No 3 Oil):		
70 hours at 100 °C	— breaking strength:	decrease $< 15$ % of $R_o$
	— elongation:	decrease $< 15$ % of $A_o$
	— volume:	swelling $< 20$ %
Immersion in distilled water:		
one week at 70 °C	— breaking strength:	decrease $< 35$ % of $R_o$
	— elongation:	increase: $< 20$ % of $A_o$

Status: EU Directives are being published on this site to aid cross referencing from UK legislation. After IP completion day (31 December 2020 11pm) no further amendments will be applied to this version.

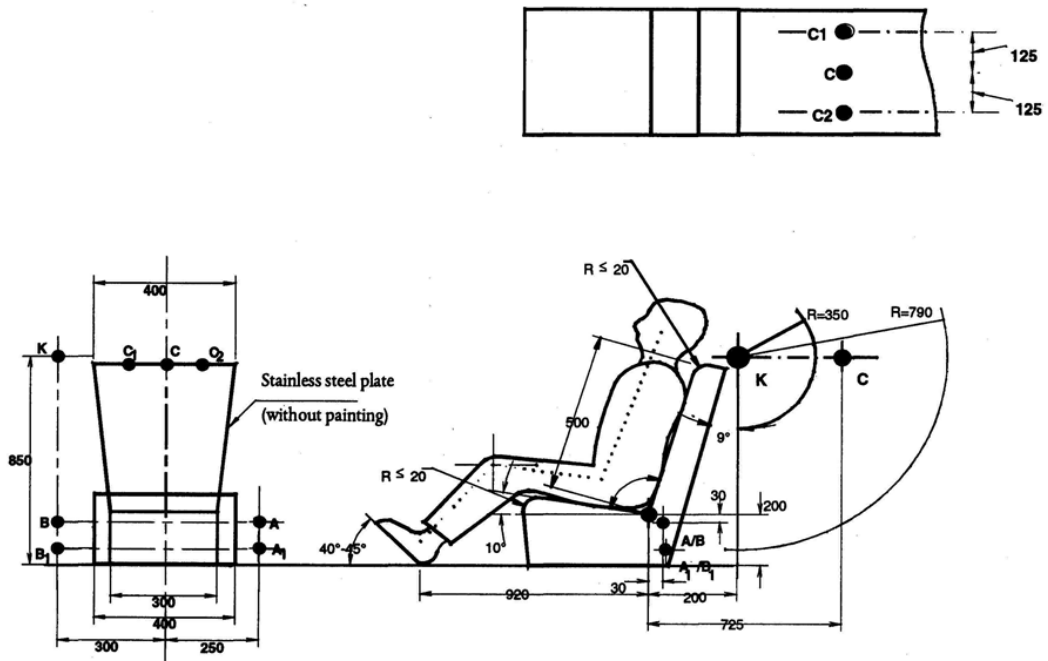

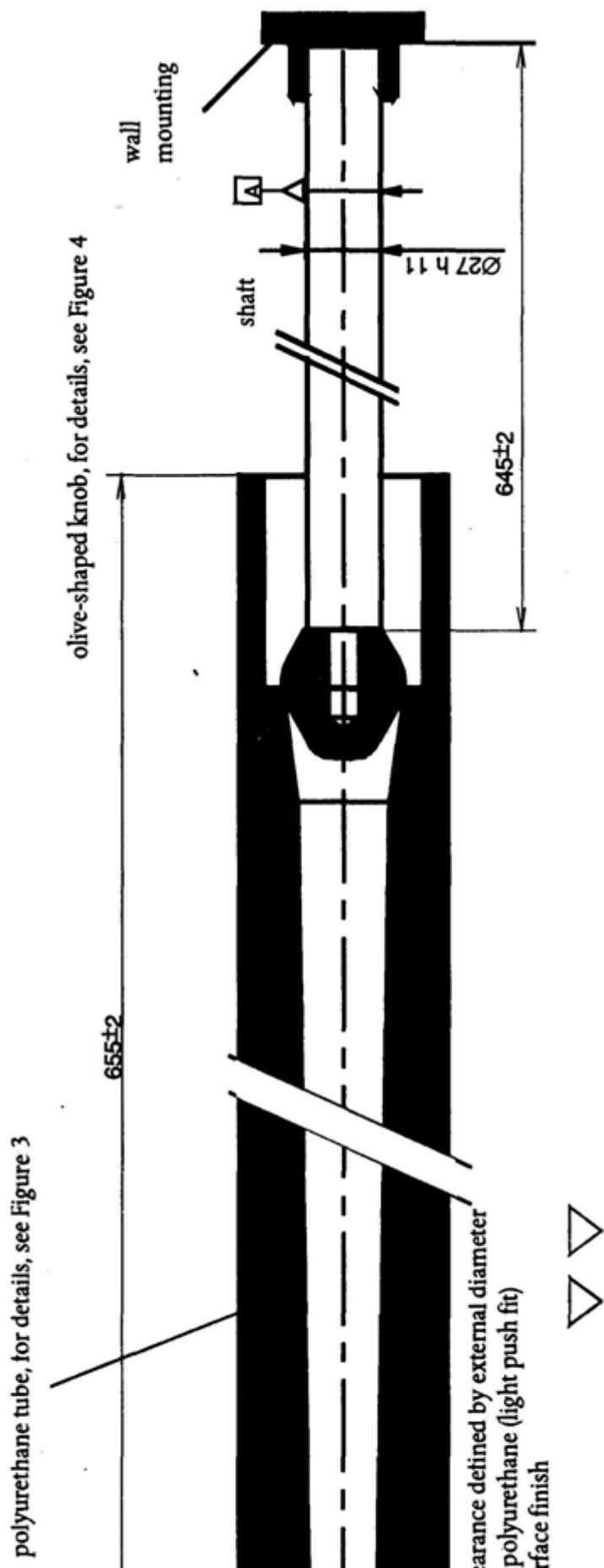

Status: EU Directives are being published on this site to aid cross referencing from UK legislation. After IP completion day (31 December 2020 11pm) no further amendments will be applied to this version.

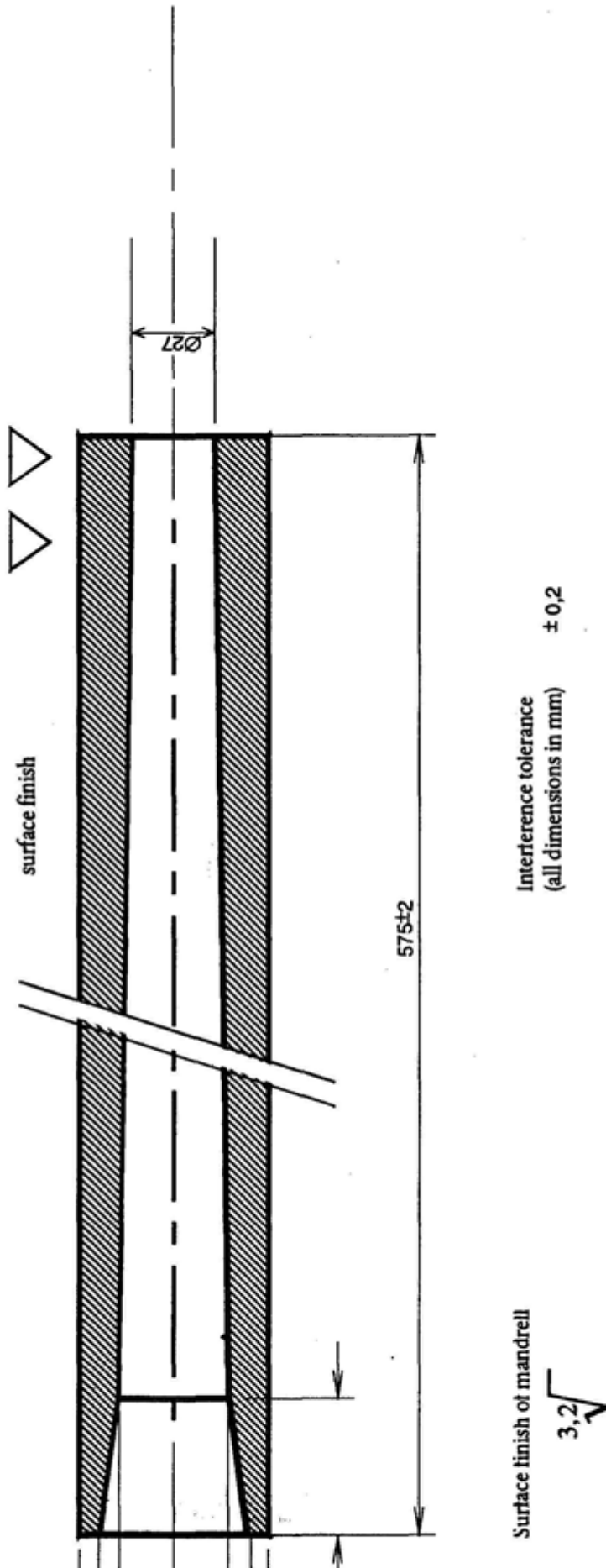



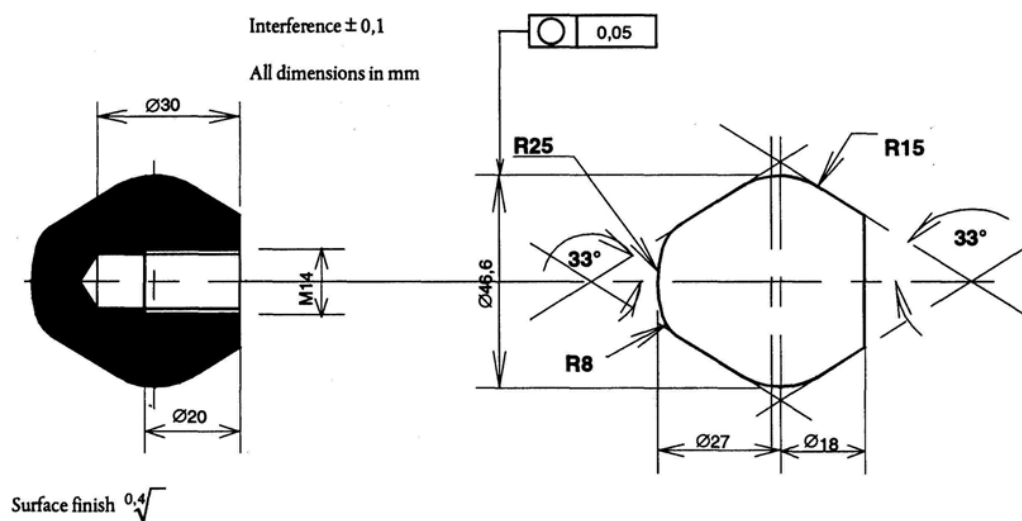

### ANNEX VIII

#### DESCRIPTION OF MANIKIN

1.	SPECIFICATIONS OF THE MANIKIN
1.1.	<p>General</p> <p>The main characteristics of the manikin are indicated in the following figures and tables:</p> <p>Figure 1 : side view of head, neck and torso;</p> <p>Figure 2 : front view of head, neck and torso;</p> <p>Figure 3 : side view of hip, thighs and lower leg;</p> <p>Figure 4 : front view of hip, thighs and lower leg;</p> <p>Figure 5 : principal dimensions;</p> <p>Figure 6 : manikin in sitting position, showing:</p> <ul style="list-style-type: none"> <li>— location of the centre of gravity,</li> <li>— location of points at which displacement shall be measured,</li> <li>— shoulder height;</li> </ul> <p>table 1 : mass of head, neck, torso, thigh and lower leg</p> <p>table 2 : references, names, materials and principal dimensions of the components of the manikin.</p>
1.2.	Description of the manikin

---

*Status: EU Directives are being published on this site to aid cross referencing from UK legislation. After IP completion day (31 December 2020 11pm) no further amendments will be applied to this version.*

---

1.2.1.	<p><i>Lower leg structure</i> (see Figures 3 and 4)  The lower leg structure consists of three components:</p> <ul style="list-style-type: none"> <li>— a sole plate (30),</li> <li>— a shin tube (29),</li> <li>— a knee tube (26).</li> </ul> <p>The knee tube has two lugs which limit the movement of the lower leg in relation to the thigh.  The lower leg can rotate rearwards about 120° from the straight position.</p>
1.2.2.	<p><i>Thigh structure</i> (see Figures 3 and 4)  The thigh structure consists of three components:</p> <ul style="list-style-type: none"> <li>— a knee tube (22),</li> <li>— a thigh bar (21),</li> <li>— a hip tube (20).</li> </ul> <p>Movement of the knee is limited by two cut-outs in the knee tube (22) which engage with the lugs of the leg.</p>
1.2.3.	<p><i>Torso structure</i> (see Figures 1 and 2)  The torso structure consists of the following components:</p> <ul style="list-style-type: none"> <li>— a hip tube (2),</li> <li>— a roller chain (4),</li> <li>— ribs (6) and (7),</li> <li>— a sternum (8),</li> <li>— chain attachments (3 and, partly, 7 and 8).</li> </ul>
1.2.4.	<p><i>Neck</i> (see Figures 1 and 2)  The neck consists of seven polyurethane discs (9). The degree of stiffness of the neck can be adjusted by means of a chain tensioner.</p>
1.2.5.	<p><i>Head</i> (see Figures 1 and 2)  The head (15) is hollow; the polyurethane is reinforced by steel bands (17). The chain tensioner which enables the neck to be adjusted consists of a polyamide block (10), a tubular spacer (11) and a tensioning component (12 and 13). The head can rotate at the joint between the first and second cervical vertebrae (the atlas-axis joint), which consists of an adjuster assembly (14 and 18), a spacer (16) and a polyamide block (10).</p>
1.2.6.	<p><i>Knee joint</i> (see Figure 4)  The lower leg and thighs are connected by a tube (27) and a tensioner (28).</p>
1.2.7.	<p><i>Hip joint</i> (see Figure 4)</p>

	The thighs and torso are connected by a tube (23), friction plates (24) and a tensioner (25).				
1.2.8.	<p><i>Polyurethane</i></p> <table border="1"> <tr> <td>Type:</td> <td>PU 123 CH compound</td> </tr> <tr> <td>Hardness:</td> <td>50 to 60 shore A</td> </tr> </table>	Type:	PU 123 CH compound	Hardness:	50 to 60 shore A
Type:	PU 123 CH compound				
Hardness:	50 to 60 shore A				
1.2.9.	<p>Overall The manikin is covered by a special overall.</p>				
2.	<p><b>CORRECTION OF THE MASS</b> In order to calibrate the manikin to certain values and its total mass, the mass distribution must be adjusted by means of six correction weights of 1 kg each which can be fitted to the hip joint. Six other polyurethane weights of 1 kg each can be fitted to the back of the torso.</p>				
3.	<p><b>CUSHION</b> A cushion shall be positioned between the chest of the manikin and the overall. This cushion must be made of polyethylene foam complying with the following specification: — hardness: 7 to 10 shore A — thickness: 25 ± 5 mm. It shall be replaceable.</p>				
4.	<b>ADJUSTMENT OF THE JOINTS</b>				
4.1.	<p>General In order to achieve reproducible results, it is necessary to specify and control the friction at each joint.</p>				
4.2.	<p>Knee joint: tighten the knee joint; set the thigh and lower leg vertical; rotate the lower leg through 30°; gradually slacken the tensioner until the lower leg starts to fall under its own weight; lock the tensioner in this position.</p>				
4.3.	<p>Hip joints: increase the rigidity of the hip joints for the purposes of adjustment; place the thighs in a horizontal position and the torso in a vertical position; rotate the torso forwards until it forms an angle of 60° with the thighs; gradually slacken the tensioner until the torso starts to fall under its own weight; lock the tensioner in this position.</p>				

*Status: EU Directives are being published on this site to aid cross referencing from UK legislation. After IP completion day (31 December 2020 11pm) no further amendments will be applied to this version.*

4.4.	Atlas-axis joint: adjust the atlas-axis joint so that it just resists its own weight in the fore and aft directions.
4.5.	Neck: the neck can be adjusted by means of the chain tensioner (13); when the neck is adjusted, the upper end of the tensioner shall be displaced between 40 and 60 mm when subjected to a horizontal load of 10 daN.

TABLE 1

Components of manikin	Mass in kilograms
Head and neck	4,6 ± 0,3
Torso and arms	40,3 ± 1,0
Thighs	16,2 ± 0,5
Lower leg and foot	9,0 ± 0,5
Total mass including correction weights	75,5 ± 1,0

TABLE 2

Reference No	Name	Material	Dimensions
1	Body	polyurethane	
2	Hip tube	steel	76 × 70 × 100 mm
3	Chain attachments	steel	25 × 10 × 70 mm
4	Roller chain	steel	$\frac{3}{4}$ mm
5	Shoulder plane	polyurethane	
6	Ribs (rolled section)	steel	30 × 30 × 3 × 250 mm
7	Ribs	perforated steelplate	400 × 85 × 1,5 mm
8	Sternum	perforated steelplate	250 × 90 × 1,5 mm
9	Discs (6)	polyurethane	# 90 × 20 mm, # 80 × 20 mm # 75 × 20 mm; # 70 × 20 mm # 65 × 20 mm, # 60 × 20 mm
10	Block	polyamide	60 × 60 × 25 mm
11	Tubular spacer	steel	40 × 40 × 2 × 50 mm
12	Tensioning bolt	steel	M16 × 90 mm
13	Tensioner nut	steel	M16

---

**Status:** EU Directives are being published on this site to aid cross referencing from UK legislation. After IP completion day (31 December 2020 11pm) no further amendments will be applied to this version.

---

14	Tensioner for atlas-axis joint	steel	# 12 × 130 mm (M12)
15	Head	polyurethane	
16	Tubular spacer	steel	# 18 × 13 × 17 mm
17	Reinforcement plate	steel	30 × 3 × 500 mm
18	Tensioner nut	steel	M12
19	Thighs	polyurethane	
20	Hip tube	steel	76 × 70 × 80 mm
21	Thigh bar	steel	30 × 30 × 440 mm
22	Knee tube	steel	52 × 46 × 40 mm
23	Hip connecting tube	steel	70 × 64 × 250 mm
24	Friction plates (4)	steel	160 × 75 × 1 mm
25	Tensioner assembly	steel	M12 × 320 mm plates and nuts
26	Knee tube	steel	52 × 46 × 160 mm
27	Knee connecting tube	steel	44 × 39 × 190 mm
28	Tensioner plate	steel	# 70 × 4 mm
29	Shin tube	steel	50 × 50 × 2 × 460 mm
30	Sole plate	steel	100 × 170 × 3 mm
31	Torso correction weights (6)	polyurethane	1 kg each
32	Cushion	polyurethane foam	350 × 250 × 25 mm
33	Overall	cotton and polyamide straps	
34	Hip joint correction weights (6)	steel	mass 1 kg each

Status: EU Directives are being published on this site to aid cross referencing from UK legislation. After IP completion day (31 December 2020 11pm) no further amendments will be applied to this version.

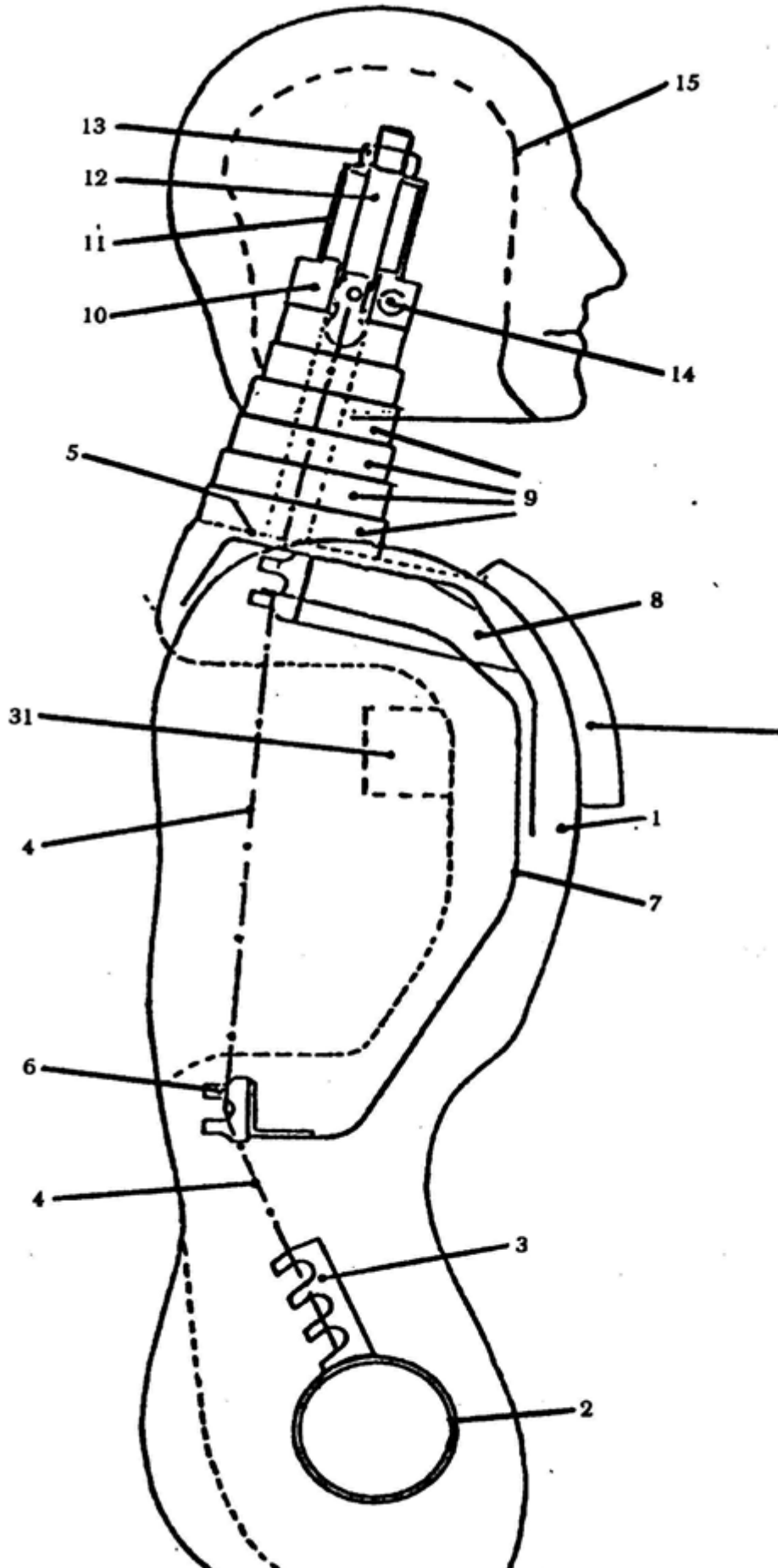

*Status: EU Directives are being published on this site to aid cross referencing from UK legislation. After IP completion day (31 December 2020 11pm) no further amendments will be applied to this version.*

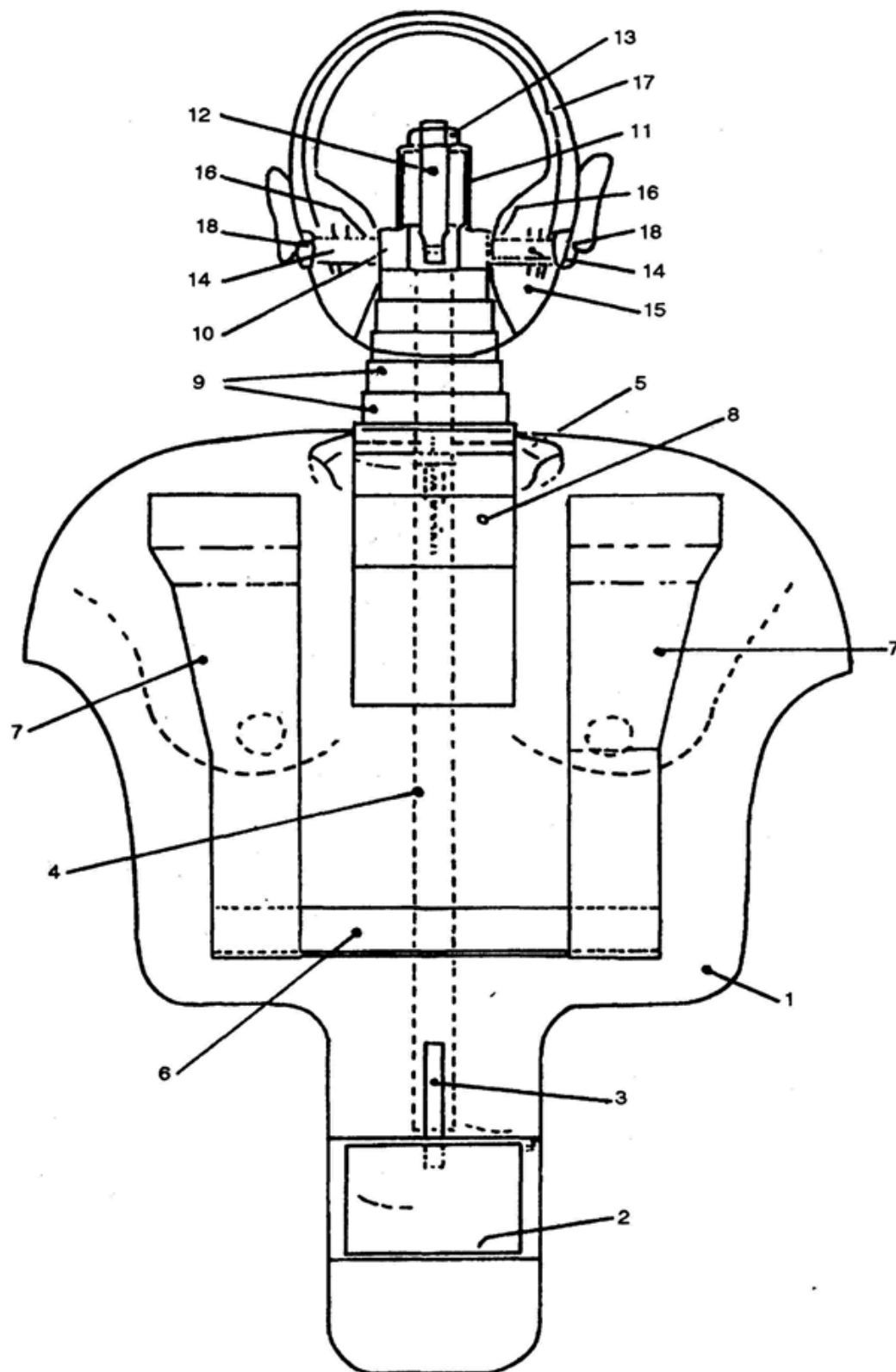

Status: EU Directives are being published on this site to aid cross referencing from UK legislation. After IP completion day (31 December 2020 11pm) no further amendments will be applied to this version.

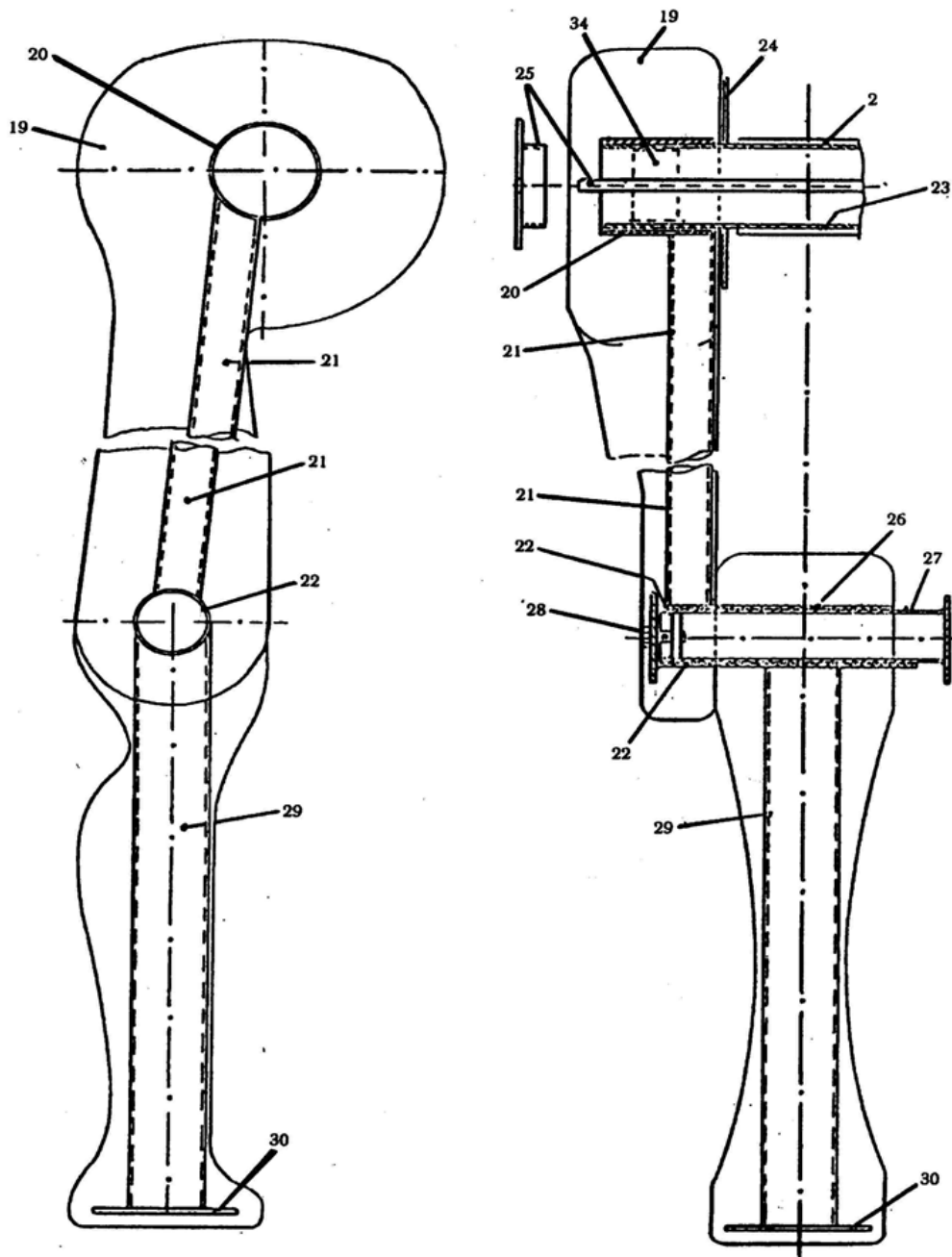



*Status: EU Directives are being published on this site to aid cross referencing from UK legislation. After IP completion day (31 December 2020 11pm) no further amendments will be applied to this version.*

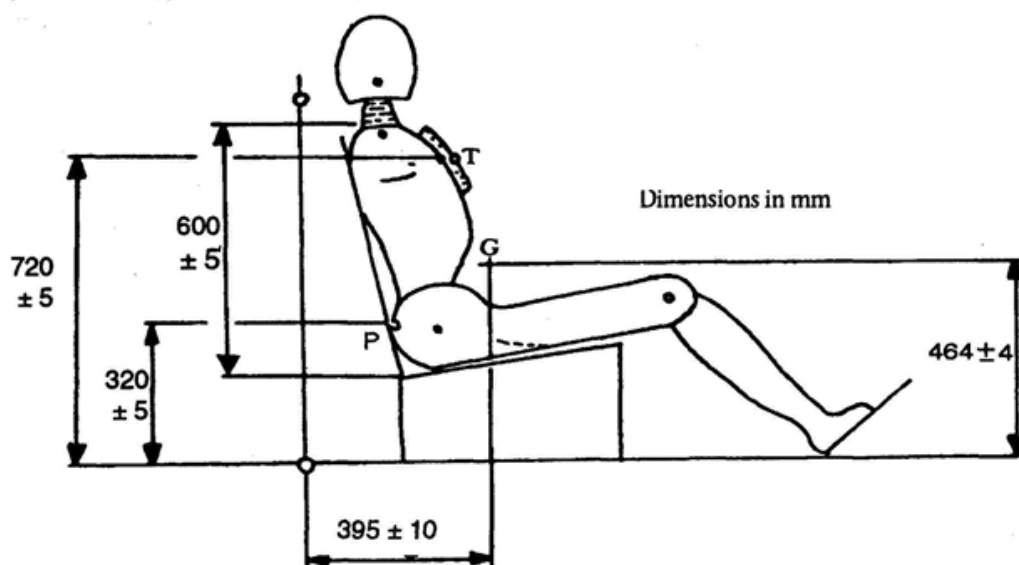
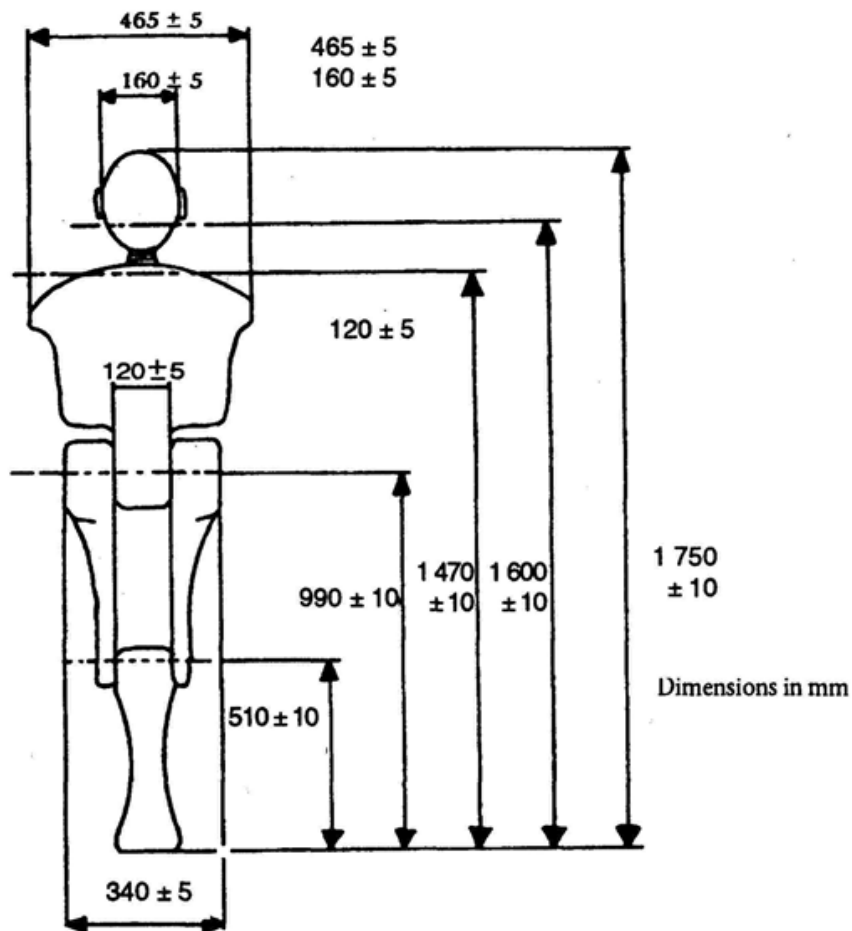

Manikin seated in position shown in Annex VII, Figure 1.

*Status: EU Directives are being published on this site to aid cross referencing from UK legislation. After IP completion day (31 December 2020 11pm) no further amendments will be applied to this version.*

- G = centre of gravity,  
 T = torso measurement point (located at the front on the centre line of the manikin),  
 P = pelvis measurement point (located at the back on the centre line of the manikin).

## ANNEX IX

DESCRIPTION OF THE CURVE OF TROLLEY  
 DECELERATION ACCORDING TO TIME  
 (Curve for testing stopping devices)

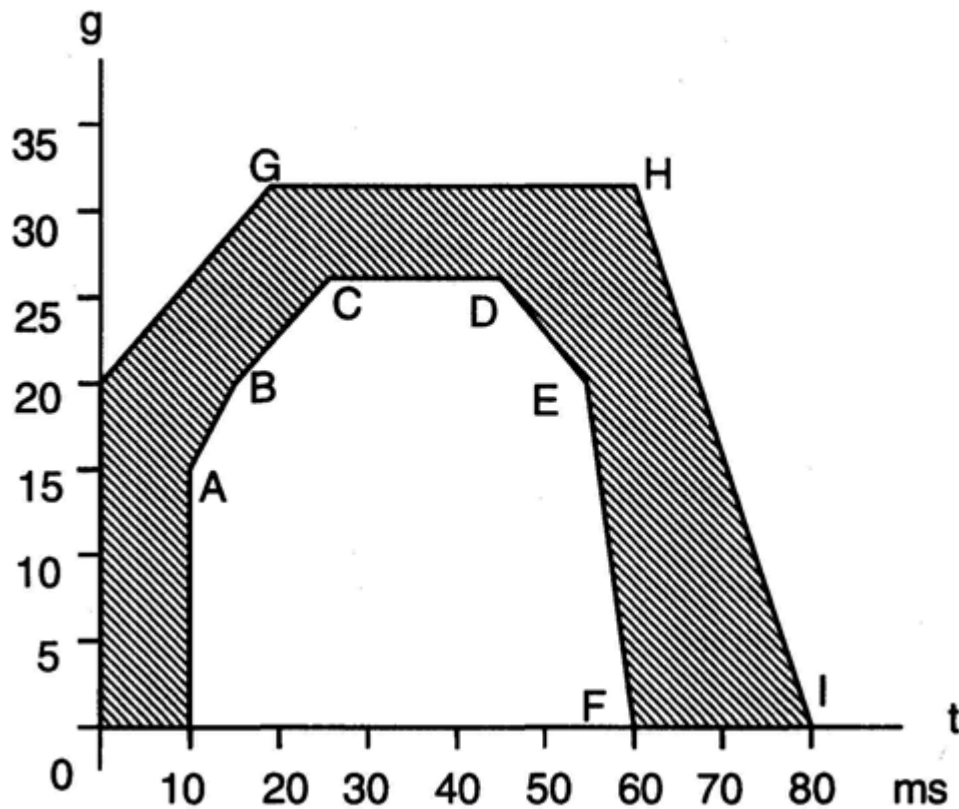

	t	g
A	10	15
B	15	20
C	25	26
D	45	26
E	55	20
F	60	0

*Status: EU Directives are being published on this site to aid cross referencing from UK legislation. After IP completion day (31 December 2020 11pm) no further amendments will be applied to this version.*

<b>G</b>	18	32
<b>H</b>	60	32
<b>I</b>	80	0

The deceleration curve of the trolley weighted with inert masses to produce a total of 455 kg  $\pm$  20 kg for safety belt tests and 910 kg  $\pm$  40 kg for restraint system tests, where the nominal mass of the trolley and vehicle structure is 800 kg, must remain within the hatched area above. If necessary, the nominal mass of the trolley and attached vehicle structure can be increased by increments of 200 kg, in which case an additional inert mass of 28 kg shall be added per increment. In no case shall the total mass of the trolley, the vehicle structure and the inert masses differ from the nominal value for calibration tests by more than  $\pm$  40 kg. The stopping distance during calibration of the trolley shall be 400  $\pm$  20 mm and the speed of the trolley shall be 50  $\pm$  1 km/h.

In both the above cases the measurement equipment shall have a response which is substantially flat up to 60 Hz with a roll off at 100 Hz. Mechanical resonances associated with transducer mounting should not distort readout data. Consideration should be given to the effect of cable length and temperature on frequency response<sup>(8)</sup>.

## ANNEX X

### INSTRUCTIONS FOR USE

Every safety belt shall be accompanied by instructions covering the following points in the language or languages of the Member State in which it is to be placed on sale.

1.	Installation instructions (not required if the manufacturer supplies the vehicle with safety belts already installed) which specify for which vehicle types the assembly is suitable and the correct method of attachment of the assembly to the vehicle, including a warning to guard against chafing of the straps.
2.	Instructions for use (they may be included in the vehicle user's handbook if the manufacturer supplies the vehicle with safety belts already installed) comprising the instructions necessary to ensure that the user obtains the greatest benefit from the safety belt. In these instructions reference should be made to: <ul style="list-style-type: none"> <li>(a) the importance of wearing the belt on all journeys;</li> <li>(b) the correct manner of wearing the belt and in particular: <ul style="list-style-type: none"> <li>— the intended location of the buckle,</li> <li>— the need for belts to fit tightly when in use,</li> </ul> </li> </ul>

*Status: EU Directives are being published on this site to aid cross referencing from UK legislation. After IP completion day (31 December 2020 11pm) no further amendments will be applied to this version.*

Every safety belt shall be accompanied by instructions covering the following points in the language or languages of the Member State in which it is to be placed on sale.

	<ul style="list-style-type: none"> <li>— the correct positioning of the straps and the need to avoid twisting them,</li> <li>— the fact that each belt should be used by one occupant only and that a belt must not be put round a child seated on a passenger's lap;</li> </ul> <p>(c) the method of fastening and unfastening the buckle;</p> <p>(d) the method of adjusting the belt;</p> <p>(e) the method of operating any retractor which is incorporated in the assembly and the method of checking that it has locked;</p> <p>(f) the recommended methods of cleaning the belt and reassembling it after cleaning where appropriate;</p> <p>(g) the need to replace the safety belt when it has been in use in a serious accident or shows signs of severe fraying or of having been cut or, when a seat belt is equipped with a pre-loading device, when the latter has been activated;</p> <p>(h) the fact that the belt must not be altered or modified in any way since such changes may render the belt ineffective; in particular where the design permits parts to be disassembled, instructions to ensure correct reassembly must be given;</p> <p>(i) the fact that the belt is intended for use by occupants of adult build;</p> <p>(j) stowage of the belt when not in use.</p>
3.	<p>In the case of safety belts fitted with a type 4N retractor, it shall be indicated in the installation instructions and on any packaging, that this belt is not suitable for installation in passenger vehicles with more than nine seats, including that of the driver.</p>
4.	<p>The vehicle manufacturer shall include in the vehicle handbook advice on the suitability of each passenger seat position for the carriage of children up to 12 years old (or 1,5 m tall), or the fitting of child restraint systems. The information shall be given in the national language, or at least one of the</p>

*Status: EU Directives are being published on this site to aid cross referencing from UK legislation. After IP completion day (31 December 2020 11pm) no further amendments will be applied to this version.*

Every safety belt shall be accompanied by instructions covering the following points in the language or languages of the Member State in which it is to be placed on sale.	
	national languages, of the country in which the vehicle is offered for sale.
4.1.	For each forward-facing passenger seat position, the manufacturer shall either:
4.1.1.	indicate that the seat position is suitable for child restraints of the universal category;
4.1.2.	provide a list of restraint systems of the universal or semi-universal, restricted or vehicle-specific categories, suitable for that vehicle seat position, indicating the age ranges for which the restraints are intended;
4.1.3.	provide a built-in child restraint indicating the age range(s) for which the restraint is intended in each configuration as appropriate; or
4.1.4.	any combination of 4.1.1, 4.1.2 and 4.1.3.
4.1.5.	If a particular age range is not covered by 4.1.1 - 4.1.4 with respect to a particular seat position, the manufacturer shall indicate that children of that age range should not be carried in that seat position.
4.1.6.	An example of a suitable format for this information is given in Appendix 1 to this Annex.

---

*Status: EU Directives are being published on this site to aid cross referencing from UK legislation. After IP completion day (31 December 2020 11pm) no further amendments will be applied to this version.*

---

## Appendix 1

Age group	Seating position			
	Front passenger	Rear passenger	Rear centre	Additional seats
< 10 kg (0 to 9 months)	X	U	L	—
< 13 kg (0 to 24 months)	U	U	L	—
9 to 18 kg (9 to 48 months)	UV	U	L	—
15 to 36 kg (4 to 12 years)	U	U	B	—

## KEY

- U : Suitable for 'universal' category restraints approved for use in this age group.
- UF : Suitable for forward-facing 'universal' category restraints approved for use in this age group.
- L : Suitable for particular child restraints given on attached list. These restraints may be of the 'specific vehicle', 'restricted', 'semi-universal' or 'universal' categories.
- B : Built-in restraint approved for this age group.
- X : Seat position not suitable for children in this age group.

ANNEX XI

DUAL BUCKLE TEST  
(outlined in 2.7.6.5 of Annex I)

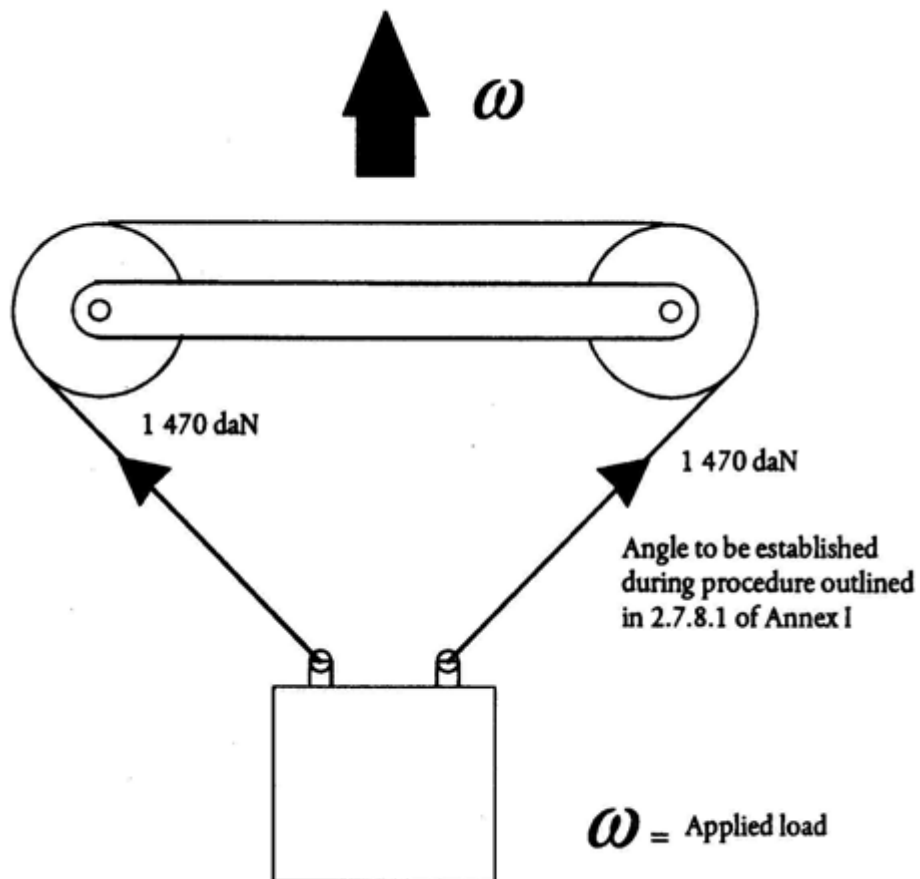

Status: EU Directives are being published on this site to aid cross referencing from UK legislation. After IP completion day (31 December 2020 11pm) no further amendments will be applied to this version.

## ANNEX XII

## ABRASION AND MICROSLIP TESTS

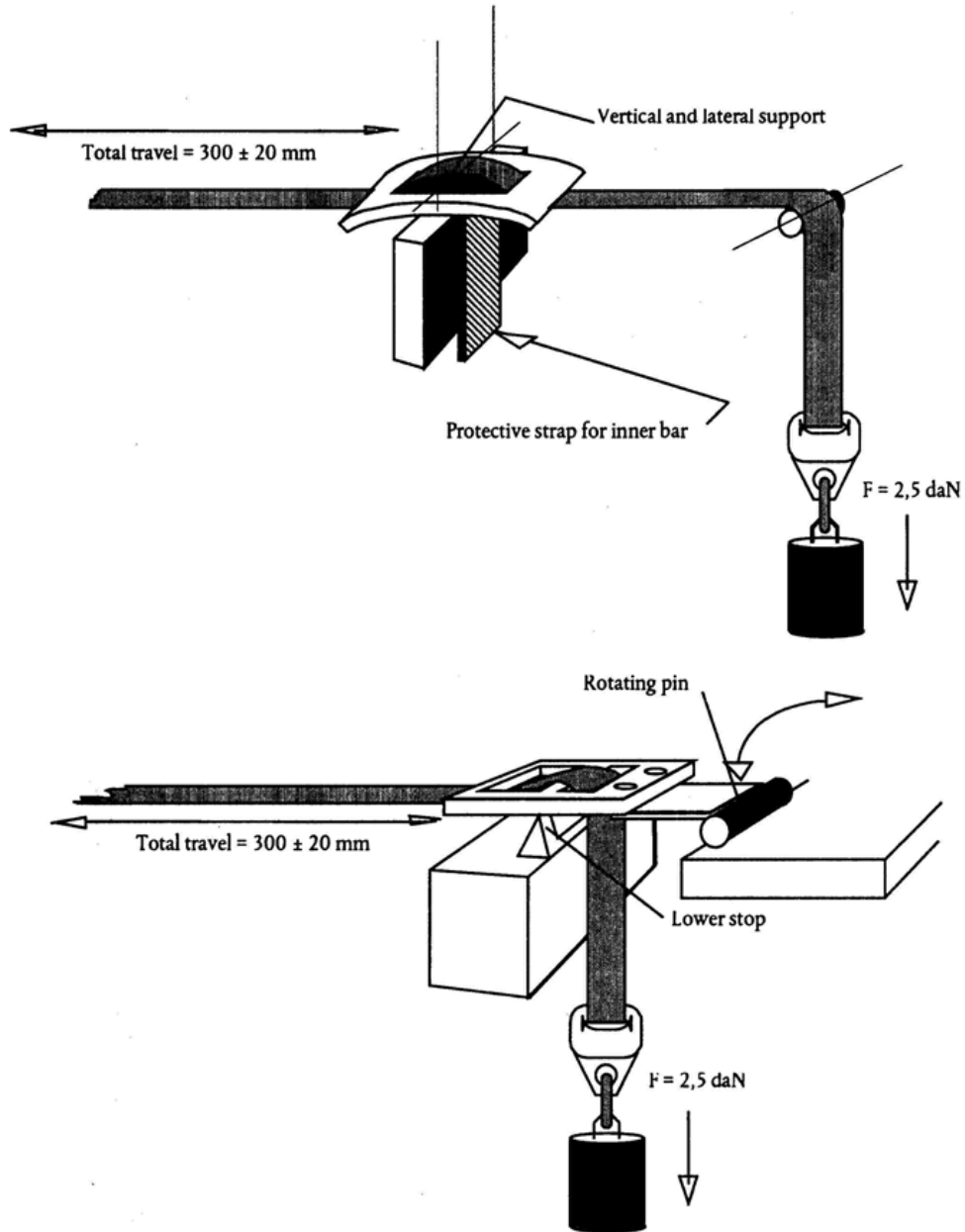

Examples of test arrangements corresponding to the type of adjusting device



*Status: EU Directives are being published on this site to aid cross referencing from UK legislation. After IP completion day (31 December 2020 11pm) no further amendments will be applied to this version.*

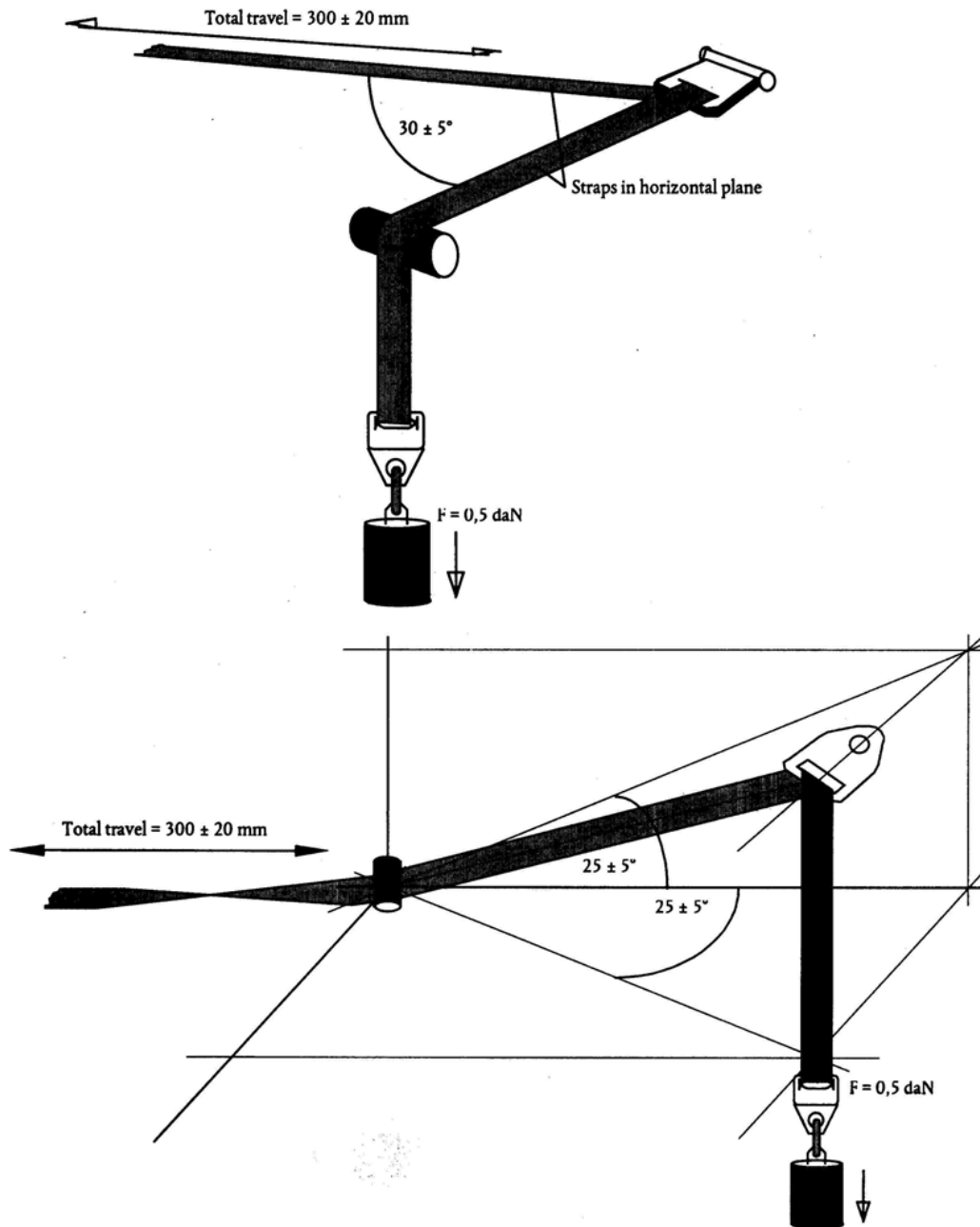

*Status: EU Directives are being published on this site to aid cross referencing from UK legislation. After IP completion day (31 December 2020 11pm) no further amendments will be applied to this version.*

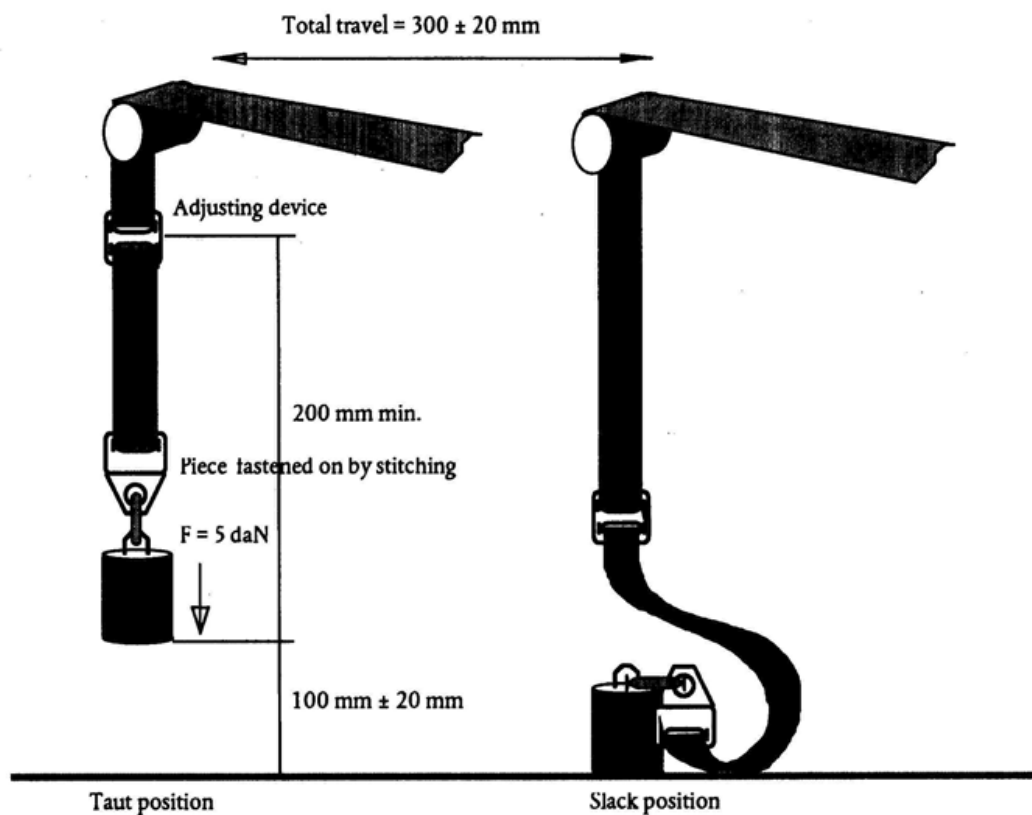

## ANNEX XIII

## CORROSION TEST

1.	TEST APPARATUS
1.1.	The apparatus shall consist of a mist chamber, a salt solution reservoir, a supply of suitably conditioned compressed air, one or more atomising nozzles, sample supports, provision for heating the chamber and the necessary means of control. The size and constructional details of the apparatus shall be optional, provided that the test conditions are met.
1.2.	It is important to ensure that drops of solution accumulated on the ceiling or cover of the chamber do not fall on test samples, and

*Status: EU Directives are being published on this site to aid cross referencing from UK legislation. After IP completion day (31 December 2020 11pm) no further amendments will be applied to this version.*

1.3.	that drops of solution which fall from test samples are not returned to the reservoir and then atomised again.
1.4.	The apparatus shall not be constructed of materials which affect the corrosiveness of the mist.
2.	LOCATION OF TEST SAMPLES IN THE MIST CABINET
2.1.	Samples, except retractors, shall be supported or suspended between 15° and 30° from the vertical and preferably parallel to the principal direction of horizontal flow of mist through the chamber, as determined, in relation to the dominant surface being tested.
2.2.	Retractors shall be supported or suspended in such a manner that the axes of the reels for storing the strap are normal to the principal direction of horizontal flow of mist through the chamber. The strap opening in the retractor shall also be facing this principal direction.
2.3.	Each sample shall be so placed as to permit the mist to settle freely on all samples.
2.4.	Each sample shall be so placed as to prevent salt solution dripping from one sample to another.
3.	SALT SOLUTION
3.1.	The salt solution shall be prepared by dissolving $5 \pm 1$ parts by mass of sodium chloride in 95 parts of distilled water. The salt shall be sodium chloride substantially free from nickel and copper and containing in the dry state not more than 0,1 % of sodium iodide and not more than 0,3 % of impurities in total.
3.2.	The solution shall be such that when atomised at 35 °C the collected solution is in the pH range of 6,5 to 7,2.
4.	AIR SUPPLY The compressed air supply to the nozzle or nozzles for atomising the salt solution shall be free from oil and impurities, and maintained at a pressure of between 70 kN/m <sup>2</sup> and 170 kN/m <sup>2</sup> .
5.	CONDITIONS IN THE MIST CHAMBER







**Status:** EU Directives are being published on this site to aid cross referencing from UK legislation. After IP completion day (31 December 2020 11pm) no further amendments will be applied to this version.

2.4.2	Buckle-opening	×																
2.7.8	test																	
2.7.9																		
2.7.1	Retention of strap sample																	×

## ANNEX XV

## MINIMUM REQUIREMENTS FOR SAFETY BELTS AND RETRACTORS

Vehicle category	Forward facing seating positions				Rear facing seating positions
	Outboard seating positions		Centre seating positions		
	Front	Other than front	Front	Other than front	
M1	Ar4m	Ar4m	Ar4m	Ar4 Ar4m	B, Br3, Br4m
M <sub>2</sub> ≤ 3,5 T	Ar4m, Ar4Nm	Ar4m, Ar4Nm	Ar4m, Ar4Nm	Ar4m, Ar4Nm	Br3, Br4m, Br4Nm
M <sub>2</sub> > 3,5 T	Br3, Br4m, Br4Nm or Ar4m, Ar4Nm ✂	Br3, Br4m, Br4Nm or Ar4m, Ar4Nm ✂	Br3, Br4m, Br4Nm or Ar4m, Ar4Nm ✂	Br3, Br4m, Br4Nm or Ar4m, Ar4Nm ✂	Br3, Br4m, Br4Nm
M3	See point 3.1.10 for conditions when a lap belt is permitted.	See point 3.1.10 for conditions when a lap belt is permitted.	See point 3.1.10 for conditions when a lap belt is permitted.	See point 3.1.10 for conditions when a lap belt is permitted.	
N1	Ar4m, Ar4Nm	B, Br3, Br4m, Br4Nm or none	B, Br3, Br4m, Br4Nm or A, Ar4m, Ar4Nm *	B, Br3, Br4m, Br4Nm or none	None
		Point 3.1.8 and 9 lap	Point 3.1.7 lap belt	Point 3.1.8 and 9 lap	

A : three-point (lap and diagonal) belt.  
 B : two-point (lap) belt.  
 r : retractor.  
 m : emergency locking retractor with multiple sensitivity.  
 3 : automatically locking retractor.  
 4 : emergency locking retractor.  
 N : higher response threshold (see Annex 1, Points 1.8.3 to 1.8.5).

*Note:* In all cases S-type belts may be fitted in place of an A or B type belt, provided anchorages complying with Directive 76/115/EEC are used.

*Status: EU Directives are being published on this site to aid cross referencing from UK legislation. After IP completion day (31 December 2020 11pm) no further amendments will be applied to this version.*

		belt required in exposed seating positions.	permitted if the windscreen is not in reference zone.	belt required in exposed seating positions.	
N2	B, Br3, Br4m, Br4Nm or A, Ar4m, Ar4Nm *	B, Br3, Br4m, Br4Nm or none #	B, Br3, Br4m, Br4Nm or A, Ar4m, Ar4Nm *	B, Br3, Br4m, Br4Nm or none #	None
N3	Point 3.1.7 lap belt permitted if the windscreen is outside reference zone and for driver's seat.	Point 3.1.8 and 9 lap belt required in exposed seating positions.	Point 3.1.7 lap belt permitted if the windscreen is not in reference zone.	Point 3.1.8 and 9 lap belt required in exposed seating positions.	
A	: three-point (lap and diagonal) belt.				
B	: two-point (lap) belt.				
r	: retractor.				
m	: emergency locking retractor with multiple sensitivity.				
3	: automatically locking retractor.				
4	: emergency locking retractor.				
N	: higher response threshold (see Annex 1, Points 1.8.3 to 1.8.5).				

*Note: In all cases S-type belts may be fitted in place of an A or B type belt, provided anchorages complying with Directive 76/115/EEC are used.*

## ANNEX XVI

### CONTROL OF CONFORMITY OF PRODUCTION

1.	TESTS Safety belts shall be required to demonstrate compliance with the requirements on which the following tests are based.
1.1.	Verification of the locking threshold and durability of emergency locking retractors According to the provisions of item 2.7.7.2, in the most unfavourable direction as appropriate after having undergone the durability testing detailed in items 2.7.2, 2.7.7.1 and 2.7.7.3, as a requirement of item 2.4.5.2.5.
1.2.	Verification of the durability of automatically locking retractors
a	For the purposes of this Annex 'sort of locking mechanism' means all emergency locking retractors whose mechanisms differ only in the lead angle(s) of the sensing device to the vehicle's reference axis system.



**Status:** EU Directives are being published on this site to aid cross referencing from UK legislation. After IP completion day (31 December 2020 11pm) no further amendments will be applied to this version.

	According to the provisions of item 2.7.7.1, supplemented by the tests in items 2.7.2 and 2.7.7.3, as a requirement of 2.4.5.1.3.
1.3.	Test for strength of straps after conditioning According to the procedure described in item 2.7.5, after conditioning according to the requirements of items 2.7.3.1 to 2.7.3.5.
1.3.1.	Test for strength of straps after abrasion According to the procedure described in item 2.7.5, after conditioning according to the requirements described in item 2.7.3.6.
1.4.	Microslip test According to the procedure described in item 2.7.4.
1.5.	Test of the rigid parts According to the procedure described in item 2.7.6.
1.6.	Verification of the performance requirements of the safety belt or restraint system when subjected to the dynamic test
1.6.1.	Tests with conditioning
1.6.1.1.	Belts or restraint systems fitted with an emergency locking retractor: according to the provisions set out in items 2.7.8 and 2.7.9, using a belt which has previously been subjected to 45 000 cycles of the endurance test of the retractor prescribed in item 2.7.7.1 and to the tests defined in items 2.4.2.3, 2.7.2 and 2.7.7.3.
1.6.1.2.	Belts or restraint systems fitted with an automatically-locking retractor: according to the provisions set out in items 2.7.8 and 2.7.9, using a belt which has previously been subjected to 10 000 cycles of the endurance test of the retractor prescribed in item 2.7.7.1 and also to the tests prescribed in items 2.4.2.3, 2.7.2 and 2.7.7.3.
1.6.1.3.	Static belt: according to the provisions set out in items 2.7.8 and 2.7.9, on a safety belt which has been subjected to the test prescribed in items 2.4.2.3 and 2.7.2.
1.6.2.	Tests without any conditioning According to the provisions set out in items 2.7.8 and 2.7.9.
2.	TEST FREQUENCY AND RESULTS

**a** For the purposes of this Annex 'sort of locking mechanism' means all emergency locking retractors whose mechanisms differ only in the lead angle(s) of the sensing device to the vehicle's reference axis system.

---

*Status: EU Directives are being published on this site to aid cross referencing from UK legislation. After IP completion day (31 December 2020 11pm) no further amendments will be applied to this version.*

---

2.1.	The frequency of testing according to the requirements of items 1.1 to 1.5 shall be on a statistically controlled and random basis in accordance with one of the regular quality assurance procedures.
2.1.1.	Furthermore, in the case of emergency locking retractors, all assemblies shall be verified:
2.1.1.1.	either according to the provisions set out in items 2.7.7.2.1 and 2.7.7.2.2, in the most unfavourable direction, as specified in item 2.7.7.2.1.2. Test results shall meet the requirements of items 2.4.5.2.1.1 and 2.4.5.2.3,
2.1.1.2.	or according to the provisions set out in item 2.7.7.2.3, in the most unfavourable direction. Nevertheless, the speed of inclination can be more than the prescribed speed in so far as it does not affect the test results. Test results shall meet the requirements of item 2.4.5.2.1.4.
2.2.1.	Tests with conditioning
2.2.1.1.	In the case of belts fitted with an emergency locking retractor, — where the daily production is greater than 1 000 belts: one in 100 000 belts produced, with a minimum frequency of one every two weeks, — where the daily production is smaller than or equal to 1 000 belts: one in 10 000 belts produced, with a minimum frequency of one per year, per sort of locking mechanism, shall be subjected to the test prescribed in Item 1.6.1.1 of this Annex. <sup>a</sup>
2.2.1.2.	In the case of belts fitted with an automatically-locking retractor and of static belts, — where the daily production is greater than 1 000 belts: one in 100 000 belts produced, with a minimum frequency of one every two weeks, — where the daily production is smaller than or equal to 1 000 belts:

---

<sup>a</sup> For the purposes of this Annex 'sort of locking mechanism' means all emergency locking retractors whose mechanisms differ only in the lead angle(s) of the sensing device to the vehicle's reference axis system.

---

**Status:** EU Directives are being published on this site to aid cross referencing from UK legislation. After IP completion day (31 December 2020 11pm) no further amendments will be applied to this version.

	one in 10 000 belts produced, with a minimum frequency of one per year, shall be subjected to the test prescribed in Item 1.6.1.2 or 1.6.1.3 of this Annex respectively.
2.2.2.	Tests without conditioning
2.2.2.1.	In the case of belts fitted with an emergency locking retractor, the following number of samples shall be subjected to the test prescribed in Item 1.6.2 of this Annex:
2.2.2.1.1.	for a production of not less than 5 000 belts per day, two belts per 25 000 produced with a minimum frequency of one per day, per sort of locking mechanism;
2.2.2.1.2.	for a production of less than 5 000 belts per day, one belt per 5 000 produced with a minimum frequency of one per year, per sort of locking mechanism.
2.2.2.2.	In the case of belts fitted with an automatically locking retractor and of static belts, the following number of samples shall be subjected to the test prescribed in Item 1.6.2 of this Annex:
2.2.2.2.1.	for a production of not less than 5 000 belts per day, two belts per 25 000 produced with a minimum frequency of one per day, per approved type,
2.2.2.2.2.	for a production of less than 5 000 belts per day, one belt per 5 000 produced with a minimum frequency of one per year, per approved type.
2.2.3.	Results Test results shall meet the requirements set out in Item 2.6.1.3.1 of Annex 1. The forward displacement of the manikin may be controlled with regard to Item 2.6.1.3.2 of Annex I (or item 2.6.1.4 where applicable) during a test performed with conditioning according to Item 1.6.1 of this Annex by means of a simplified adapted method.
2.2.3.1.	In the case of approval following paragraph 2.6.1.3.3 of Annex I to this Directive and paragraph 1.6.1 of this Annex, it is only specified that no part of the belt

**a** For the purposes of this Annex 'sort of locking mechanism' means all emergency locking retractors whose mechanisms differ only in the lead angle(s) of the sensing device to the vehicle's reference axis system.

---

*Status: EU Directives are being published on this site to aid cross referencing from UK legislation. After IP completion day (31 December 2020 11pm) no further amendments will be applied to this version.*

---

	shall be destructed or disengaged, and that a speed of 24 km/h of the chest reference point at 300 mm displacement shall not be exceeded.
2.3.	Where a test sample fails a particular test to which it has been subjected, a further test to the same requirements shall be carried out on at least three other samples. In the case of dynamic tests if one of the latter fails the test, the holder of the approval or his duly accredited representative shall notify the competent authority which has granted type approval indicating what steps have been taken to re-establish the conformity of production.
<b>a</b>	For the purposes of this Annex 'sort of locking mechanism' means all emergency locking retractors whose mechanisms differ only in the lead angle(s) of the sensing device to the vehicle's reference axis system.

## ANNEX XVII

### REQUIREMENTS FOR CHILD RESTRAINT SYSTEMS

The requirements for the approval of child restraint systems are found in Paragraphs 2, 6, 7, 8, 9 and 14 of Regulation 44 of the United Nations Economic Commission for Europe<sup>(9)</sup>, together with Annexes 3 to 21, up to and including the 03 series of amendments.

(References in Paragraphs 6 to 8 above to Regulations 14, 16 and 21 are understood as Directive 76/115/EEC, this Directive and Directive 74/60/EEC.)

## ANNEX XVIII

### INSTALLATION REQUIREMENTS FOR CHILD RESTRAINT SYSTEMS

The requirements for the installation of child restraint systems are found in Annex 13 of Consolidated Resolution R.E.3 of the United Nations Economic Commission for Europe, Item 5.2 and Appendix 2, reproduced in Appendix to this Annex.

## Appendix 1

The text reproduced below refers to Annex 13 (Item 5.2 and Appendix 2 ) of the United Nations Economic Commission for Europe Consolidated Resolution R.E.3. (document TRANS/WP.29/78/Rev.1 of 11 August 1997).

### ANNEX RECOMMENDATION ON THE REQUIREMENTS FOR THE INSTALLATION 13 OF SAFETY BELTS AND RESTRAINT SYSTEMS FOR ADULT OCCUPANTS OF MOTOR VEHICLES ON FORWARD AND REARWARD FACING SEATS

---

5.2.	A 'universal' category child restraint means a child restraint approved to the 'universal' category of ECE Regulation No 44, 03 series of amendments. Seat positions which are indicated by the vehicle manufacturer as being suitable for the installation of child restraints of the 'universal' category shall comply with the provisions of Appendix 2 to this Annex.
------	---

---

---

*Status: EU Directives are being published on this site to aid cross referencing from UK legislation. After IP completion day (31 December 2020 11pm) no further amendments will be applied to this version.*

---

## Appendix 2

Provisions concerning the installation of 'universal' category child restraint systems installed with the safety belt equipment of the vehicle

1.	GENERAL
1.1.	The test procedure and the requirements in this appendix shall be used to determine the suitability of seat positions for the installation of child restraints of the 'universal' category.
1.2.	The tests may be carried out in the vehicle or in a representative part of the vehicle.
2.	TEST PROCEDURE
2.1.	Adjust the seat to its fully rearward and lowest position.
2.2.	Adjust the seat-back angle to the manufacturer's design position. In the absence of any specification, an angle of 25 degrees from the vertical, or the nearest fixed position of the seat-back, should be used.
2.3.	Set the shoulder anchorage to the lowest position.
2.4.	Place a cotton cloth on the seat-back and cushion.
2.5.	Place the fixture (as described in Figure 1 of this appendix) on the vehicle seat.
2.6.	If the seating position is intended to accommodate a forward-facing or rearward-facing universal restraint system, proceed according to paragraphs 2.6.1, 2.7, 2.8, 2.9 and 2.10. If the seating position is intended to accommodate only a forward-facing universal restraint system, proceed according to paragraphs 2.6.2, 2.7, 2.8, 2.9 and 2.10.
2.6.1.	Arrange the safety belt strap around the fixture in approximately the correct position as shown in Figures 2 and 3, then latch the buckle.
2.6.2.	Arrange the safety belt lap strap approximately in the correct position around the lower part of the fixture of 150 mm radius as shown in Figure 3, then latch the buckle.
2.7.	Ensure that the fixture is located with its centre line on the apparent centre line of the

---

**Status:** EU Directives are being published on this site to aid cross referencing from UK legislation. After IP completion day (31 December 2020 11pm) no further amendments will be applied to this version.

---

	seating position $\pm 25$ mm with its centre line parallel with the centre line of the vehicle.
2.8.	Ensure that all webbing slack is removed. Use sufficient force to remove the slack, do not attempt to tension the webbing.
2.9.	Push rearwards on the centre of the front of the fixture with a force of $100\text{ N} \pm 10\text{ N}$ , applied parallel to the lower surface, and remove the force.
2.10.	Push vertically downwards on the centre of the upper surface of the fixture with a force of $100\text{ N} \pm 10\text{ N}$ , and remove the force.
3.	REQUIREMENTS
3.1.	The base of the fixture shall contact both the forward and rearward parts of the seat cushion surface. If such contact does not occur due to the belt access gap in the test fixture, this gap may be covered in line with the bottom surface of the test fixture.
3.2.	The lap portion of the belt shall touch the fixture on both sides at the rear of the lap belt path (see Figure 3).
3.3.	Should the above requirements not be met with the adjustments indicated in paragraphs 2.1, 2.2 and 2.3, the seat, seat-back and safety belt anchorages may be adjusted to an alternative position designated by the manufacturer for normal use at which the above installation procedure shall be repeated and the requirements again verified and met.]

Status: EU Directives are being published on this site to aid cross referencing from UK legislation. After IP completion day (31 December 2020 11pm) no further amendments will be applied to this version.

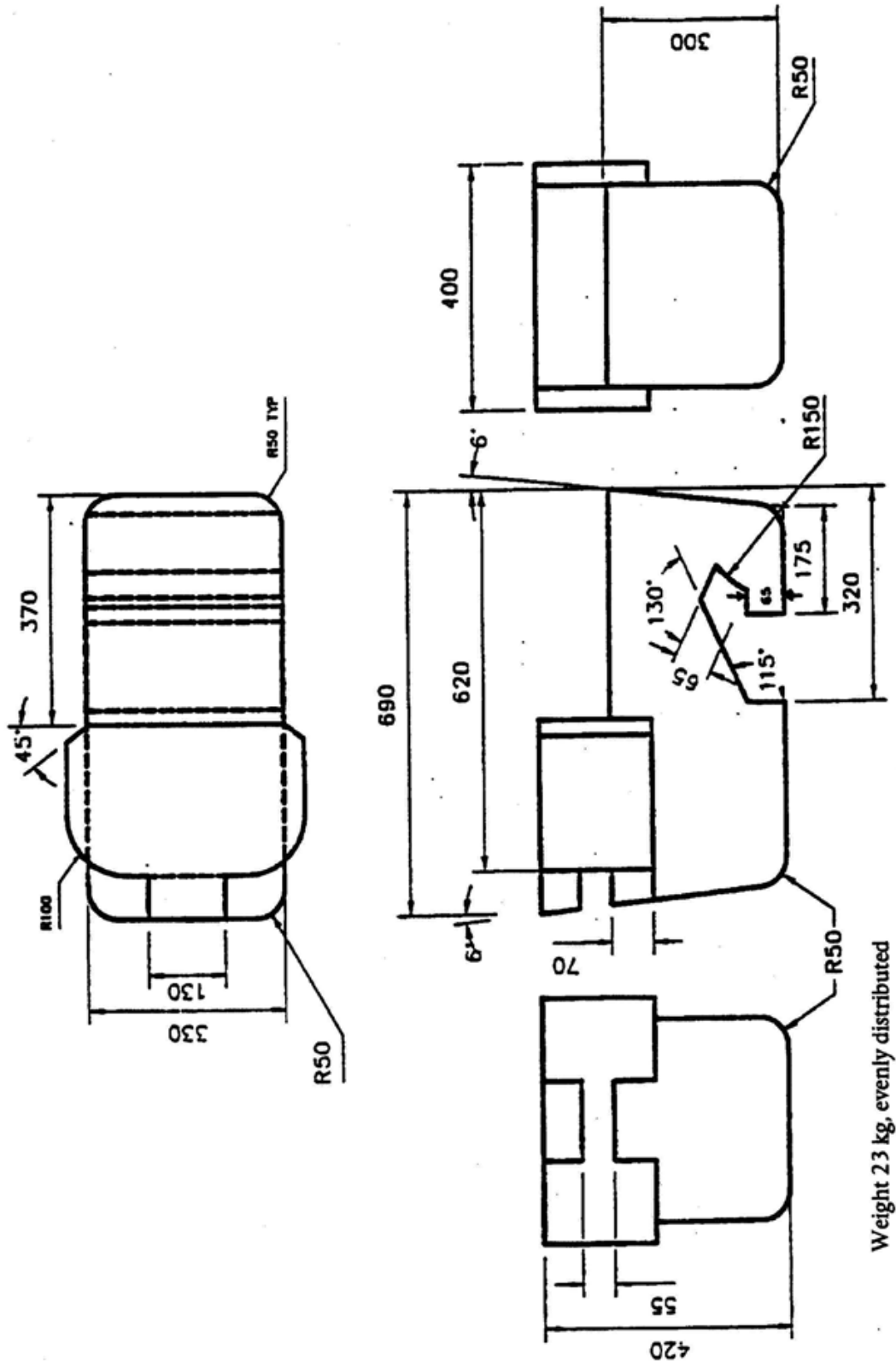



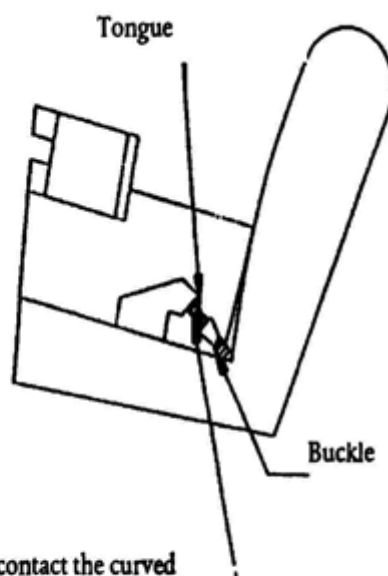
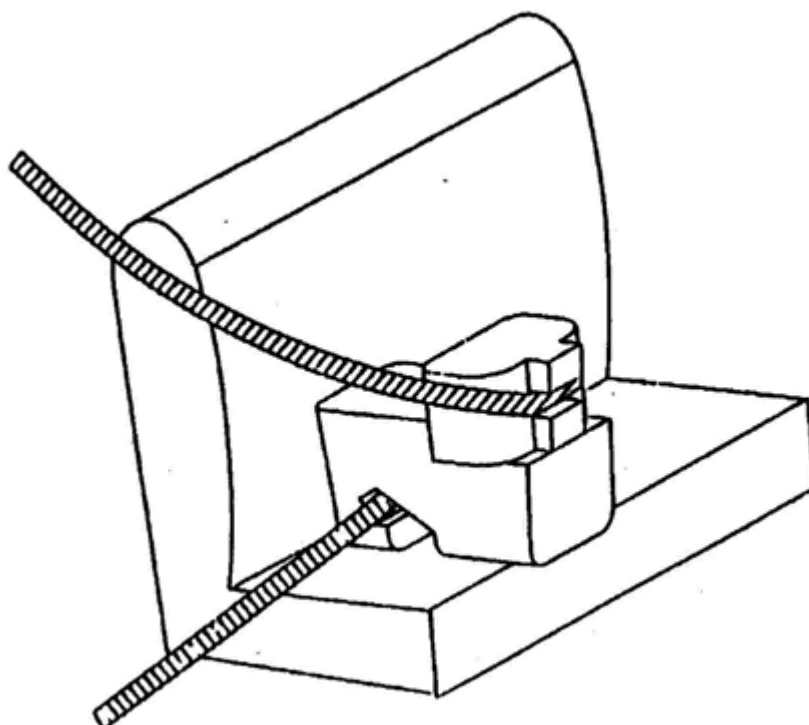

**Note:** The seat belt webbing must contact the curved edge on both sides of the fixture.

Lap belt only shown

---

**Status:** EU Directives are being published on this site to aid cross referencing from UK legislation. After IP completion day (31 December 2020 11pm) no further amendments will be applied to this version.

---

---

*Status: EU Directives are being published on this site to aid cross referencing from UK legislation. After IP completion day (31 December 2020 11pm) no further amendments will be applied to this version.*

---

- (1) OJ No C 76, 7. 4. 1975, p. 37.
- (2) OJ No C 263, 17. 11. 1975, p. 37.
- (3) OJ No L 42, 23. 2. 1970, p. 1.
- (4) OJ No L 38, 11. 2. 1974, p. 2.
- (5) OJ No L 165, 20. 6. 1974, p. 16.
- (6) OJ No L 221, 12. 8. 1974, p. 1.
- (7) OJ No L 24, 30. 1. 1976, p. 6.
- (8) [<sup>F4</sup>These requirements are in accordance with Recommendation ISO R 6478/1980.
- (9) Reproduced and published in the Official Journal.]

---

**Textual Amendments**

- F4** Substituted by Commission Directive 2000/3/EC of 22 February 2000 adapting to technical progress Council Directive 77/541/EEC relating to safety belts and restraint systems of motor vehicles (Text with EEA relevance).