

II

(Acts whose publication is not obligatory)

COUNCIL

COUNCIL DIRECTIVE

of 27 September 1977

on the approximation of the laws of the Member States relating to the field of vision of motor vehicle drivers

(77/649/EEC)

THE COUNCIL OF THE EUROPEAN COMMUNITIES,

Having regard to the Treaty establishing the European Economic Community, and in particular Article 100 thereof,

Having regard to the proposal from the Commission,

Having regard to the opinion of the European Parliament ⁽¹⁾,

Having regard to the opinion of the Economic and Social Committee ⁽²⁾,

Whereas the technical requirements which motor vehicles must satisfy pursuant to national laws relate, *inter alia*, to the field of vision of the driver;

Whereas these requirements differ from one Member State to another; whereas it is therefore necessary that all Member States adopt the same requirements, either in addition to or in place of their existing rules, in order, in particular, to allow the EEC type-approval procedure, which was the subject of Council Directive 70/156/EEC of 6 February 1970 on the approximation of the laws of the Member States relating to the type-approval of motor vehicles and their trailers, to be introduced in respect of each type of vehicle ⁽³⁾;

Whereas it is desirable to draft the technical requirements so that they have the same aim as the work being carried out on the subject in the UN Economic Commission for Europe;

Whereas those requirements apply to motor vehicles in category M₁ (the international classification of motor vehicles is given in Annex I to Directive 70/156/EEC);

Whereas the approximation of national laws relating to motor vehicles entails reciprocal recognition by Member States of the checks carried out by each of them on the basis of the common requirements,

HAS ADOPTED THIS DIRECTIVE:

Article 1

For the purposes of this Directive, 'vehicle' means any motor vehicle in category M₁ (defined in Annex I to Directive 70/156/EEC) intended for use on the road, having at least four wheels and a maximum design speed exceeding 25 km/h.

Article 2

No Member State may refuse to grant EEC type-approval or national type-approval of a vehicle on grounds relating to the driver's field of vision if it satisfies the requirements set out in Annexes I, III and IV.

⁽¹⁾ OJ No C 125, 8. 6. 1976, p. 49.

⁽²⁾ OJ No C 197, 23. 8. 1976, p. 10.

⁽³⁾ OJ No L 42, 23. 2. 1970, p. 1.

Article 3

No Member State may refuse or prohibit the sale, registration, entry into service or use of any vehicle on grounds relating to the driver's field of vision if it satisfies the requirements set out in Annexes I, III and IV.

Article 4

The Member State which has granted type-approval shall take the measures required to ensure that it is informed of any modification of a part or characteristic referred to in section 2.2 of Annex I. The competent authorities of that State shall determine whether it is necessary to carry out further tests on the modified vehicle type and to prepare a new report. If these tests show that the requirements of this Directive have not been complied with, the modification shall not be authorized.

Article 5

Any amendments necessary to adapt the requirements of Annexes I, III, IV and V to technical progress shall be adopted in accordance with the procedure laid down in Article 13 of Directive 70/156/EEC.

However, this procedure shall not apply to amendments introducing provisions relating to a field of vision other than 180° forward field of vision.

Article 6

1. Member States shall bring into force the provisions necessary in order to comply with this Directive within 18 months of its notification and shall forthwith inform the Commission thereof.

2. Member States shall ensure that the texts of the main provisions of national law which they adopt in the field covered by this Directive are communicated to the Commission.

Article 7

This Directive is addressed to the Member States.

Done at Brussels, 27 September 1977.

For the Council

The President

A. HUMBLET

List of Annexes

Annex I: Scope, definitions, application for EEC type-approval, EEC type-approval, specifications, test procedure ⁽¹⁾.

(*Annex II*)

Annex III: Procedure for determining the 'H' point and the actual seat-back angle and for verifying the relative positions of the R and H points and the relationship between the design seat-back angle and the actual seat-back angle ⁽¹⁾.

Annex IV: Method for determining the dimensional relationships between the vehicle's primary reference marks and the three-dimensional reference grid ⁽¹⁾.

Annex V: Annex to the EEC vehicle type-approval certificate with regard to the driver's field of vision.

⁽¹⁾ The technical requirements of this Annex are similar to those of the relevant UN Economic Commission for Europe draft Regulation; in particular the breakdown into sections is the same. Where a section of the draft Regulation has no counterpart in the Annexes to this Directive, the number is given in brackets for the record.

ANNEX I

SCOPE, DEFINITIONS, APPLICATION FOR EEC TYPE-APPROVAL, EEC TYPE-APPROVAL, SPECIFICATIONS, TEST PROCEDURE

1. SCOPE
 - 1.1. This Directive applies to the 180° forward field of vision of the drivers of vehicles in category M₁.
 - 1.1.1. Its purpose is to ensure an adequate field of vision when the windscreen and other glazed surfaces are dry and clean.
 - 1.2. The requirements of this Directive are so worded as to apply to category M₁ vehicles in which the driver is on the left. In category M₁ vehicles in which the driver is on the right these requirements shall be applied by inverting the criteria where appropriate.
2. DEFINITIONS
 - (2.1.)
 - 2.2. **Vehicle type with regard to the field of vision**

'Vehicle type with regard to the field of vision' means vehicles which do not differ in such essential respects as:

 - 2.2.1. the external and internal forms and arrangements within the area specified in section 1 which may affect visibility; and
 - 2.2.2. the shape and dimensions of the windscreen and its mounting.
 - 2.3. **Three-dimensional reference grid**

'Three-dimensional reference grid' means a reference system which consists of a vertical longitudinal plane X-Z, a horizontal plane X-Y and a vertical transverse plane Y-Z (see Annex IV, Appendix, figure 5); the grid is used to determine the dimensional relationships between the position of design points on drawings and their position on the actual vehicle. The procedure for situating the vehicle relative to the grid is specified in Annex IV; all coordinates referred to ground zero shall be based on a vehicle in running order (as defined in section 2.6 of Annex I to Directive 70/156/EEC) plus one front-seat passenger, the mass of the passenger being 75 kg ± 1 %.

 - 2.3.1. Vehicles fitted with suspension enabling their ground clearance to be adjusted shall be tested under the normal conditions of use specified by the vehicle manufacturer.
 - 2.4. **Primary reference marks**

'Primary reference marks' means holes, surfaces, marks and identification signs on the vehicle body. The type of reference mark used and the position of each mark relative to the X, Y and Z coordinates of the three-dimensional reference grid and to a design ground plane shall be specified by the vehicle manufacturer. These marks may be the control points used for body-assembly purposes;
 - 2.5. **Seat-back angle**

(See Annex III, section 1.3)
 - 2.6. **Actual seat-back angle**

(See Annex III, section 1.4)
 - 2.7. **Design seat-back angle**

(See Annex III, section 1.5)

- 2.8. **V points**
'V points' means points whose position in the passenger compartment is determined as a function of vertical longitudinal planes passing through the centres of the outermost designated seating positions on the front seat and in relation to the R point and the design angle of the seat-back, which points are used for verifying compliance with the field of vision requirements;
- 2.9. **R point or seating reference point**
(See Annex III, section 1.2)
- 2.10. **H point**
(See Annex III, section 1.1)
- 2.11. **Windscreen datum points**
'Windscreen datum points' means points situated at the intersection with the windscreen of lines radiating forward from the V points to the outer surface of the windscreen.
- 2.12. **Transparent area**
'Transparent area' means that area of a vehicle windscreen or other glazed surface whose light transmittance measured at right angles to the surface, is not less than 70 %.
- 2.13. **P points**
'P points' means the points about which the driver's head rotates when he views objects on a horizontal plane at eye level.
- 2.14. **E points**
'E points' means points representing the centres of the driver's eyes and used to assess the extent to which A pillars obscure the field of vision.
- 2.15. **A pillar**
'A pillar' means any roof support forward of the vertical transverse plane located 68 mm in front of the V points and includes non-transparent items, such as windscreen mouldings and door frames, attached or contiguous to such a support.
- 2.16. **Horizontal seat-adjustment range**
'Horizontal seat-adjustment range' means the range of normal driving positions designated by the vehicle manufacturer for the adjustment of the driver's seat in the direction of the X axis (see 2.3).
- 2.17. **Extended seat adjustment range**
'Extended seat adjustment range' means the range designated by the vehicle manufacturer for the adjustment of the seat in the direction of the X axis (see 2.3) beyond the range of normal driving positions specified in 2.16 and used for converting seats into beds or facilitating entry into the vehicle.
- (2.18.)
3. **APPLICATION FOR EEC TYPE-APPROVAL**
- 3.1. The application for EEC type-approval of a vehicle type with regard to the driver's field of vision shall be submitted by the vehicle manufacturer or by his authorized representative.
- 3.2. It shall be accompanied by the following documents in triplicate, and by the following particulars;
- 3.2.1. a description of the vehicle with regard to the items mentioned in 2.2, together with dimensional drawings and either a photograph or an exploded view of the passenger compartment. The numbers and/or symbols identifying the vehicle type shall be specified; and

- 3.2.2. particulars of the primary reference marks in sufficient detail to enable them to be readily identified and the position of each in relation to the others and to the R point to be verified.
- 3.3. A vehicle representative of the vehicle type to be approved shall be submitted to the technical service conducting the approval tests.
4. EEC TYPE-APPROVAL
- (4.1.)
- (4.2.)
- 4.3. A certificate conforming to the model shown in Annex V shall be attached to the EEC type-approval certificate.
- (4.4.) — (4.4.1) — (4.4.2)
- (4.5.)
- (4.6.)
- (4.7.)
- (4.8.)
5. SPECIFICATIONS
- 5.1. Driver's field of vision
- 5.1.1. The transparent area of the windscreen must include at least the windscreen datum points; these are:
- 5.1.1.1. a horizontal datum point forward of V_1 and 17° to the left (see Annex IV, Appendix, figure 1);
- 5.1.1.2. an upper vertical datum point forward of V_1 and 7° above the horizontal. However, this angle shall be reduced to 5° until 30 September 1981.
- 5.1.1.3. a lower vertical datum point forward of V_2 and 5° below the horizontal;
- 5.1.1.4. to verify compliance with the forward-vision requirement on the opposite half of the windscreen, three additional datum points, symmetrical to the points defined in 5.1.1.1 to 5.1.1.3 in relation to the median longitudinal plane of the vehicle, are obtained.
- 5.1.2. The angle of binocular obstruction of each A pillar shall not exceed the following values at the level of the pivotal points P_1 and P_2 of the head (see Annex IV, Appendix, figure 2):
- until 30 September 1981: 7°
from 1 October 1981: 6°
- 5.1.2.1. The angle of binocular obstruction is measured in a horizontal plane between tangents connecting:
- 5.1.2.1.1. E_1 to the rearward side and E_2 to the forward side of the left A pillar, and
- 5.1.2.1.2. E_3 to the forward side and E_4 to the rearward side of the right A pillar.
- 5.1.2.2. No vehicle shall have more than two A pillars.
- 5.1.3. There shall be no obstructions, other than those created by A pillars and/or vent window division bars, rear-view mirrors and windscreen wipers, in the driver's 180° forward direct field of vision below a horizontal plane through V_1 and above three planes through V_2 , one being perpendicular to the plane X-Z and declining forward 4° below the horizontal and the other two being perpendicular to the plane Y-Z and declining 4° below the horizontal (see Annex IV, Appendix, figure 3).
- However, rear-view mirrors may only be mounted within the field of vision defined above if, when they are located in a different position, the requirements of Council

Directive 71/127/EEC of 1 March 1971 on the approximation of the laws of the Member States relating to the rear-view mirrors of motor vehicles are no longer met ⁽¹⁾.

- 5.1.3.1. An obstruction created by the steering-wheel rim and the instrument panel inside the steering wheel will be tolerated if a plane through V_2 , perpendicular to the plane X-Z and tangential to the highest part of the steering-wheel rim, is declined at least 1° below the horizontal.

5.2. Position of the V points

- 5.2.1. The positions of the V points in relation to the R point, as indicated by XYZ coordinates from the three-dimensional reference grid, are as shown in Tables I and IV.

- 5.2.1.1. Table I indicates the basic coordinates for a design seat-back angle of 25° . The positive direction for the coordinates is indicated in Annex IV, Appendix, figure 1.

TABLE I

V-point	X	Y	Z
V_1	68 mm	- 5 mm	665 mm
V_2	68 mm	- 5 mm	589 mm

5.3. Positions of the P points

- 5.3.1. The positions of the P points in relation to the R point, as indicated by the XYZ coordinates from the three-dimensional reference grid, are as shown by Tables II, III and IV.

- 5.3.1.1. Table II indicates the basic coordinates for a design seat-back angle of 25° . The positive direction for the coordinates is indicated in Annex IV, Appendix, figure 1.

TABLE II

P-point	X	Y	Z
P_1	35 mm	- 20 mm	627 mm
P_2	63 mm	47 mm	627 mm

- 5.3.1.2. Table III indicates the further corrections to be made to the X coordinates of P_1 and P_2 when the horizontal seat-adjustment range as defined in 2.16 exceeds 108 mm. The positive direction for the coordinates is indicated in Annex IV, Appendix, figure 1.

⁽¹⁾ OJ No L 68, 22. 3. 1971, p. 1.

TABLE III

Horizontal seat-adjustment range	ΔX
108 to 120 mm	— 13 mm
121 to 132 mm	— 22 mm
133 to 145 mm	— 32 mm
146 to 158 mm	— 42 mm
more than 158 mm	— 48 mm

5.4. Correction for design seat-back angles other than 25°

Table IV indicates the further corrections to be made to the X and Z coordinates of each P point and each V point when the design seat-back angle is not 25°. The positive direction for the coordinates is indicated in Annex IV, Appendix, figure 1.

TABLE IV

Seat-back angle (in °)	Horizontal coordinates ΔX	Vertical coordinates ΔZ	Seat-back angle (in °)	Horizontal coordinates ΔX	Vertical coordinates ΔZ
5	— 186 mm	28 mm	23	— 18 mm	5 mm
6	— 177 mm	27 mm	24	— 9 mm	3 mm
7	— 167 mm	27 mm	25	0 mm	0 mm
8	— 157 mm	27 mm	26	9 mm	— 3 mm
9	— 147 mm	26 mm	27	17 mm	— 5 mm
10	— 137 mm	25 mm	28	26 mm	— 8 mm
11	— 128 mm	24 mm	29	34 mm	— 11 mm
12	— 118 mm	23 mm	30	43 mm	— 14 mm
13	— 109 mm	22 mm	31	51 mm	— 18 mm
14	— 99 mm	21 mm	32	59 mm	— 21 mm
15	— 90 mm	20 mm	33	67 mm	— 24 mm
16	— 81 mm	18 mm	34	76 mm	— 28 mm
17	— 72 mm	17 mm	35	84 mm	— 32 mm
18	— 62 mm	15 mm	36	92 mm	— 35 mm
19	— 53 mm	13 mm	37	100 mm	— 39 mm
20	— 44 mm	11 mm	38	108 mm	— 43 mm
21	— 35 mm	9 mm	39	115 mm	— 48 mm
22	— 26 mm	7 mm	40	123 mm	— 52 mm

5.5. Positions of the E points

5.5.1. E_1 and E_2 are each 104 mm from P_1 .

E_2 is 65 mm from E_1 (see Annex IV, Appendix, figure 4).

- 5.5.2. The line joining E_1 and E_2 is rotated about P_1 until it is normal to the vertical median longitudinal plane of the vehicle, provided that:
- 5.5.2.1. In such position a tangent from E_1 to the rearward edge of the left A pillar forms an angle of 120° or less with the line $E_1 - E_2$;
- 5.5.2.2. Where the angle so included is more than 120° , rotation of the line $E_1 - E_2$ about P_1 shall be adjusted until the resultant included angle equals 120° (in the latter case see Annex IV, Appendix, figure 2).
- 5.5.3. E_3 and E_4 are each 104 mm from P_2 . E_3 is 65 mm from E_4 . (See Annex IV, Appendix, figure 4).
- 5.5.4. The line $E_3 - E_4$ is rotated about P_2 until it forms an angle of 120° with the tangent from E_4 to the rearward edge of the right A pillar (see Annex IV, Appendix, figure 2).
6. TEST PROCEDURE
- 6.1. Driver's field of vision
- 6.1.1. The dimensional relationships between the vehicle's primary reference marks and the three-dimensional reference grid shall be determined by the procedure prescribed in Annex IV.
- 6.1.2. The position of the points V_1 and V_2 are determined in relation to the R point as indicated by XYZ coordinates from the three-dimensional reference grid and are shown in Table I under 5.2.1.1 and Table IV under 5.4. The windscreen datum points shall then be found from the corrected V points as prescribed in 5.1.1.
- 6.1.3. The relationship between the P points, the R point, and the centre-line of the driver's seating position, as indicated by XYZ coordinates from the three-dimensional reference grid, shall be determined from Tables II and III in 5.3. The correction for design seat-back angles other than 25° is shown in Table IV under 5.4.
- 6.1.4. The angle of binocular obstruction (see 5.1.2) shall be measured in the horizontal plane as indicated in Annex IV, Appendix, figure 2. The relationship between P_1 and P_2 , which are connected to E_1 and E_2 and E_3 and E_4 respectively, is shown in Annex IV, Appendix, figure 4.
- 6.1.4.1. The line $E_1 - E_2$ shall be set as described in 5.5.2. The angle of binocular obstruction is then measured between the tangent connecting E_1 to the outer edge of the left A pillar and the tangent connecting E_2 to the inner edge of the left A pillar.
- 6.1.4.2. The line $E_3 - E_4$ shall be set as described in 5.5.4. The angle of binocular obstruction is then measured between the tangent connecting E_4 to the outer edge of the right A pillar and the tangent connecting E_3 to the inner edge of the right A pillar.
- (7.)
- (8.)
- (9.)
- (10.)

(ANNEX II)

ANNEX III

PROCEDURE FOR DETERMINING THE H POINT AND THE ACTUAL SEAT-BACK ANGLE AND FOR VERIFYING THE RELATIVE POSITIONS OF THE R AND H POINTS AND THE RELATIONSHIP BETWEEN THE DESIGN SEAT-BACK ANGLE AND THE ACTUAL SEAT-BACK ANGLE**1. DEFINITIONS****1.1. H point**

The 'H point', which indicates the position of a seated occupant in the passenger compartment, is the intersection, in a longitudinal vertical plane, of the theoretical axis of rotation between the thighs and torso of a human body represented by the manikin described in section 3.

1.2. R point or seating reference point

The 'R point' or 'seating reference point' is the reference point specified by the vehicle manufacturer which

1.2.1. has coordinates determined in relation to the vehicle structure;

1.2.2. corresponds to the theoretical position of the point of torso/thighs rotation (H point) for the lowest and most rearward normal driving position or position of use given by the vehicle manufacturer for each seating position specified by him.

1.3. Seat-back angle

'Seat-back angle' means the inclination of the seat-back in relation to the vertical.

1.4. Actual seat-back angle

'Actual seat-back angle' means the angle formed by the vertical through the H point with the torso reference line of the human body represented by the manikin described in section 3.

1.5. Design seat-back angle

'Design seat-back angle' means the angle prescribed by the vehicle manufacturer which

1.5.1. determines the seat-back angle for the lowest and most rearward normal driving position or position of use given by the vehicle manufacturer for each seating position specified by him;

1.5.2. is formed at the R point by the vertical and the torso reference line; and

1.5.3. corresponds theoretically to the actual seat-back angle.

2. DETERMINATION OF H POINTS AND ACTUAL SEAT-BACK ANGLES

2.1. An H point and an actual seat-back angle shall be determined for each seating position specified by the vehicle manufacturer. If the seating positions in the same row can be regarded as similar (bench seat, identical seats, etc.), only one H point and one actual seat-back angle shall be determined for each row of seats, the manikin described in section 3 being seated in a place regarded as representative for the row. This place shall be:

2.1.1. in the case of the front row, the driver's seat;

2.1.2. in the case of the rear row or rows, an outer seat;

2.2. When an H point and an actual seat-back angle are being determined, the seat considered shall be placed in the lowest and most rearward normal driving position or position of use given for it by the vehicle manufacturer. The seat-back shall, if its inclination is adjustable, be locked as specified by the manufacturer, or in the absence of any such specification, in a position corresponding to an actual seat-back angle of as near as possible to 25°.

3. DESCRIPTION OF THE MANIKIN

- 3.1. A three-dimensional manikin of a mass and contour corresponding to those of an adult male of average height shall be used. Such a manikin is depicted in figures 1 and 2 of the Appendix to this Annex.
- 3.2. The manikin shall comprise:
 - 3.2.1. two components, one simulating the back and the other the seat of the body, pivoting on an axis representing the axis of rotation between the torso and the thigh. The intersection of this axis with the vertical medium longitudinal plane of the seating position determines the H point;
 - 3.2.2. two components simulating the legs and pivotally attached to the component simulating the seat; and
 - 3.2.3. two components simulating the feet and connected to the legs by pivotal joints simulating ankles.
 - 3.2.4. In addition, the component simulating the seat of the body shall be provided with a level enabling its transverse orientation to be verified.
- 3.3. Body-segment weights shall be attached at appropriate points corresponding to the relevant centres of gravity, so as to bring the total mass of the manikin up to $75 \text{ kg} \pm 1 \%$. Details of the mass of the various weights are given in the table in figure 2 of the Appendix to this Annex.
- 3.4. The torso reference line of the manikin is represented by a straight line passing through the joint between the thigh and the torso and the theoretical joint between the neck and the thorax (see the Appendix to this Annex, figure 1).

4. SETTING UP THE MANIKIN

The three-dimensional manikin shall be set up in the following manner:

- 4.1. the vehicle shall be placed on a horizontal plane and the seats adjusted as prescribed in 2.2;
- 4.2. the seat to be tested shall be covered with a piece of cloth to facilitate the correct setting-up of the manikin;
- 4.3. the manikin shall be placed on the seat concerned, its pivotal axis being perpendicular to the median longitudinal plane of the vehicle;
- 4.4. the feet of the manikin shall be placed as follows:
 - 4.4.1. in the front seats, in such a way that the level verifying the transverse orientation of the seat of the manikin is brought to the horizontal;
 - 4.4.2. in the rear seats, as far as possible in such a way as to be in contact with the front seats. If the feet then rest on parts of the floor which are at different levels, the foot which first comes into contact with the front seat shall serve as a reference point and the other foot shall be so arranged that the level enabling the transverse orientation of the seat of the manikin to be verified is brought to the horizontal;
 - 4.4.3. if the H point is being determined at a centre seat, the feet shall be placed one on each side of the tunnel;
- 4.5. the weights shall be placed on the legs, the level verifying the transverse orientation of the seat of the manikin shall be brought to the horizontal, and the thigh weights shall be placed on the component representing the seat of the manikin;
- 4.6. the manikin shall be moved away from the seat-back by means of the knee-pivot bar and the back of the manikin shall be pivoted forwards. The manikin shall be re-positioned on the seat of the vehicle by being slid backwards on its seat until resistance is encountered, the back of the manikin then being replaced against the seat-back;
- 4.7. a horizontal load of $10 \pm 1 \text{ daN}$ shall be applied to the manikin twice. The direction and point of application of the load are shown by a black arrow in figure 2 of the Appendix;

- 4.8. the seat weights shall be installed on the right and left sides, and the torso weights shall then be placed in position. The transverse level of the manikin shall be kept horizontal;
- 4.9. the transverse level of the manikin being kept horizontal, the back of the manikin shall be pivoted forwards until the torso weights are above the H point, so as to eliminate any friction with the seat-back;
- 4.10. the back of the manikin shall be gently moved rearwards so as to complete the setting-up operation. The transverse level of the manikin shall be horizontal. If it is not, the procedure described above shall be repeated.

5. RESULTS

- 5.1. When the manikin has been set up as described in section 4, the H point and the actual seat-back angle of the vehicle seat considered are constituted by the H point and the angle of inclination of the manikin's torso reference line.
- 5.2. The coordinates of the H point in relation to three mutually perpendicular planes, and the actual seat-back angle, shall be measured for comparison with the data supplied by the vehicle manufacturer.

6. VERIFYING THE RELATIVE POSITIONS OF THE R AND H POINTS AND THE RELATIONSHIP BETWEEN THE DESIGN SEAT-BACK ANGLE AND THE ACTUAL SEAT-BACK ANGLE

- 6.1. The results of the measurements carried out in accordance with 5.2 for the H point and the actual seat-back angle shall be compared with the coordinates of the R point and the design seat-back angle as given by the vehicle manufacturer.
- 6.2. The relative positions of the R point and the H point and the relationship between the design seat-back angle and the actual seat-back angle shall be considered to be satisfactory for the seating position in question if the H point, as defined by its coordinates, lies within a longitudinal rectangle whose horizontal and vertical sides are 30 mm and 20 mm long respectively and whose diagonals intersect at the R point, and if the actual seat-back angle is within 3° of the design seat-back angle.
 - 6.2.1. If these conditions are met, the R point and the design seat-back angle shall be used for the test and, if necessary, the manikin shall be so adjusted that the H point coincides with the R point and the actual seat-back angle coincides with the design seat-back angle.
- 6.3. If the H point or the actual seat-back angle does not satisfy the requirements of 6.2, the H point or the actual seat-back angle shall be determined twice more (three times in all). If the results of two of these three operations satisfy the requirements, the results of the test shall be considered to be satisfactory.
- 6.4. If at least two of the three test results do not satisfy the requirements of 6.2, the result of the test shall be considered to be not satisfactory.
- 6.5. If the situation described in 6.4 arises, or if verification is not possible because the vehicle manufacturer has failed to supply information regarding the position of the R point or regarding the design seat-back angle, the average of the results of the three tests may be used and be regarded as applicable in all cases where the R point or the design seat-back angle is referred to in this Directive.
- 6.6. For verifying the relative positions of the R point and the H point and the relationship between the design seat-back angle and the actual seat-back angle in a series-produced vehicle, the rectangle referred to in 6.2 shall be replaced by a square of 50 mm side and the actual seat-back angle shall not differ by more than 5° from the design seat-back angle.

Appendix

COMPONENTS OF THREE-DIMENSIONAL MANIKIN

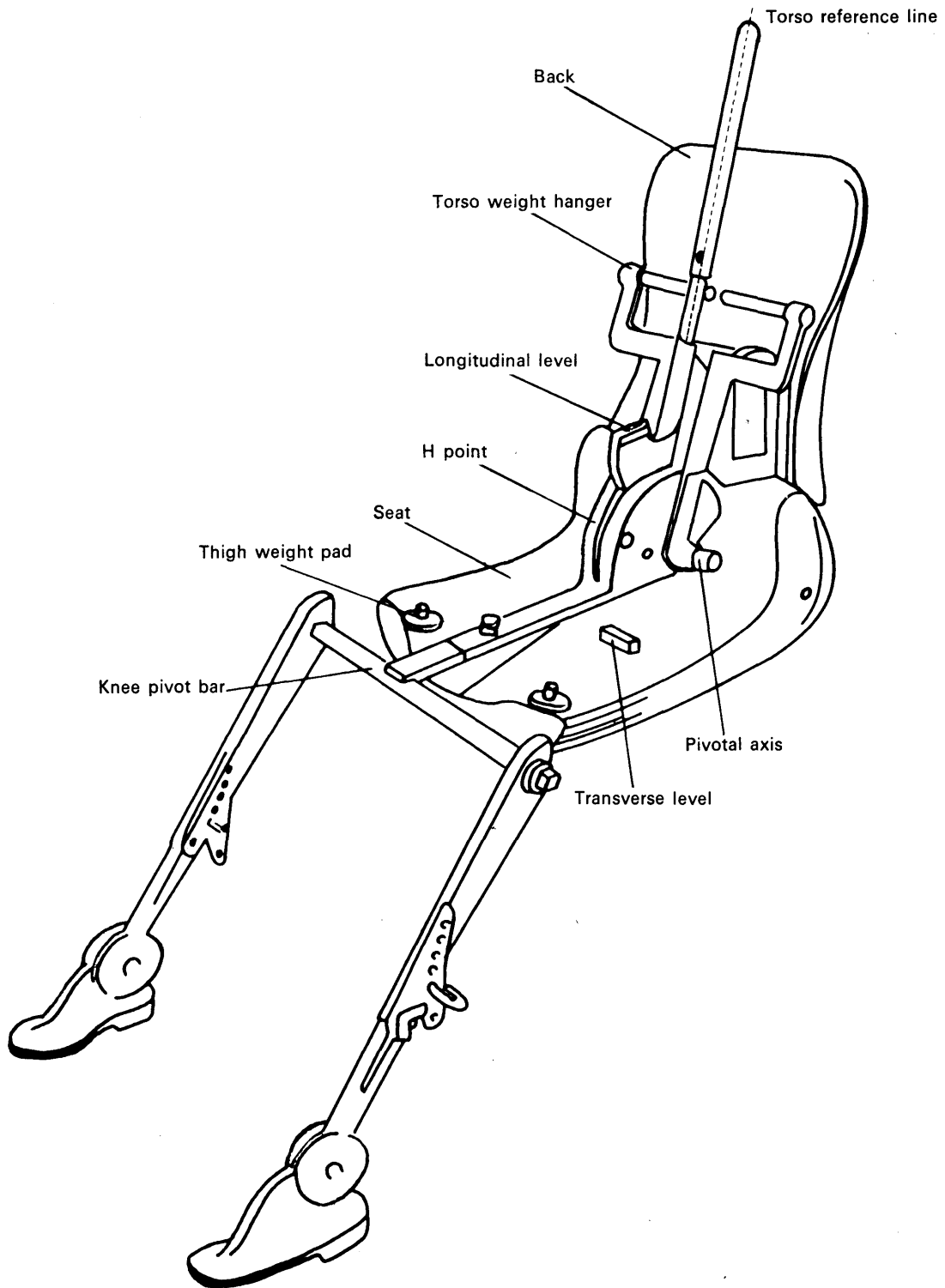

Figure 1

DIMENSIONS AND MASS OF MANIKIN

<i>Mass of manikin</i>	<i>kg</i>
Components simulating back and seat of body	16
Mass of torso weights	31
Mass of seat weights	8
Mass of thigh weights	7
Mass of leg weights	13
Total:	75

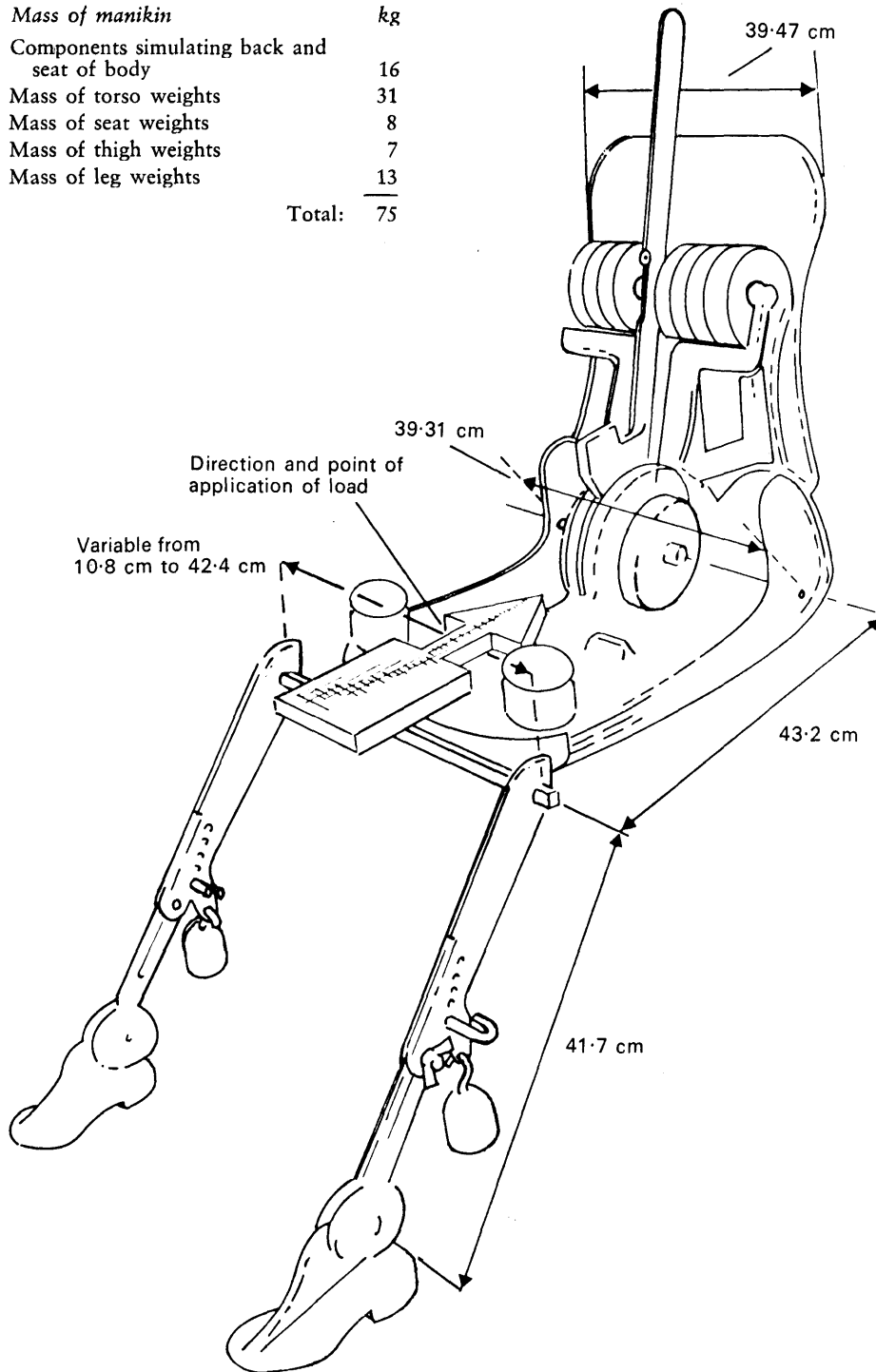

Figure 2

ANNEX IV

METHOD FOR DETERMINING THE DIMENSIONAL RELATIONSHIPS BETWEEN THE VEHICLE'S PRIMARY REFERENCE MARKS AND THE THREE-DIMENSIONAL REFERENCE GRID**1. RELATIONSHIP BETWEEN REFERENCE GRID AND VEHICLE PRIMARY REFERENCE MARKS**

To verify specific dimensions on or within a vehicle submitted for type-approval in accordance with this Directive, the relationship between the coordinates of the three-dimensional reference grid, defined in 2.3 of Annex I, which has been laid out at the initial vehicle-design stage, and the positions of the primary reference marks defined in 2.4 of Annex I, must be established accurately so that specific points on the vehicle manufacturer's drawings can be identified on an actual vehicle produced from those drawings.

2. METHOD FOR ESTABLISHING RELATIONSHIP OF REFERENCE GRID TO REFERENCE MARKS

For this purpose, a ground reference plane shall be constructed which is marked with the X-X measurement and the Y-Y measurement. The method of achieving this is set out in figure 6 of the Appendix to this Annex, the reference plane being a hard, flat, level surface upon which the vehicle stands, and which has two measuring scales firmly fixed to its surface; these shall be graduated in millimetres, the X-X scale being not less than eight metres long, and the Y-Y scale not less than four metres long. The two scales must be set at right angles to each other as shown in figure 6 of the Appendix to this Annex. The intersection of these scales is ground zero.

3. EXAMINATION OF THE REFERENCE PLANE

In order to provide for minor variations in the level of the reference plane or test area, it will be necessary to measure the deviations from ground zero along both the X and Y scales at intervals of 250 mm and to record the readings obtained so that corrections can be made when checking the vehicle.

4. ACTUAL TEST ATTITUDE

In order to provide for minor changes in suspension height, etc., it will be necessary to have available a means of bringing the primary reference marks to the correct coordinate positions relative to the design attitude before further measurements are taken. In addition, it must be possible to make minor lateral and/or longitudinal adjustments of the vehicle's position so as to place it accurately in relation to the reference grid.

5. RESULTS

The vehicle having been correctly placed relative to the reference grid and in its design attitude, the site of the necessary points for studying the forward visibility requirements can be readily determined.

Test methods to determine these requirements may include the use of theodolites, light sources or shadow devices, or any other method which can be shown to give equivalent results.

Figure 1

DETERMINATION OF V POINTS

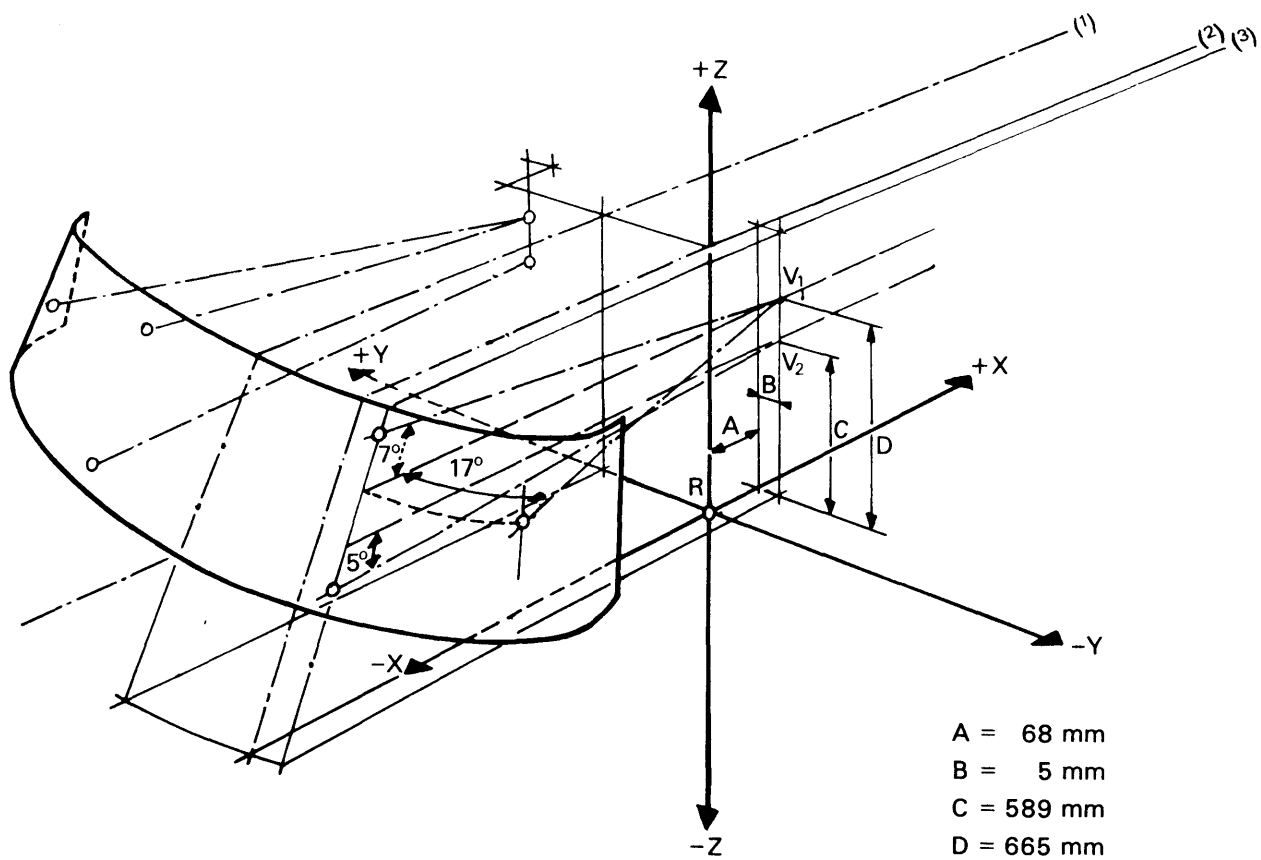

- (1) Line tracing the median longitudinal plane of the vehicle.
- (2) Line tracing the vertical plane passing through R.
- (3) Line tracing the vertical plane passing through V₁ and V₂.

Figure 2

PILLAR OBSTRUCTION

Diagram showing layout of P points and E points, for viewing the left-hand and right-hand pillars

(special case provided for in section 5.5.2.2 of Annex I)

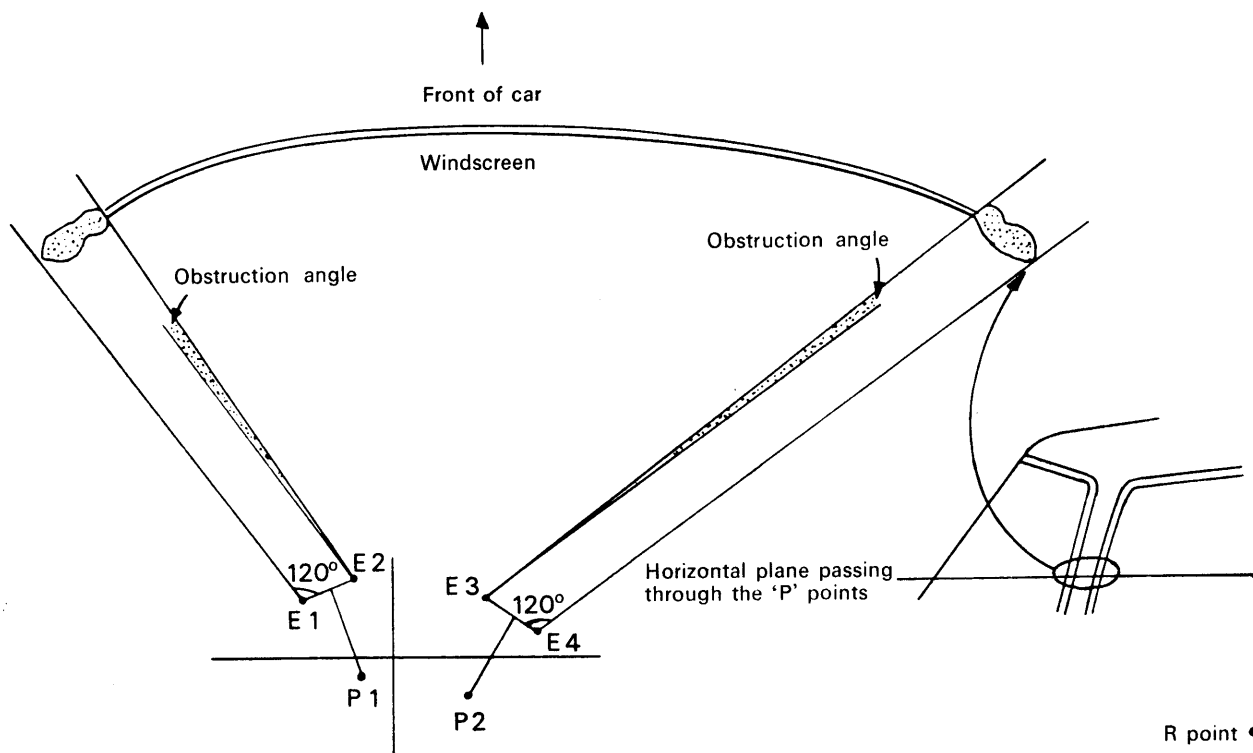

Figure 3

EVALUATION OF OBSTRUCTIONS IN THE 180° FORWARD DIRECT FIELD OF VISION OF THE DRIVER

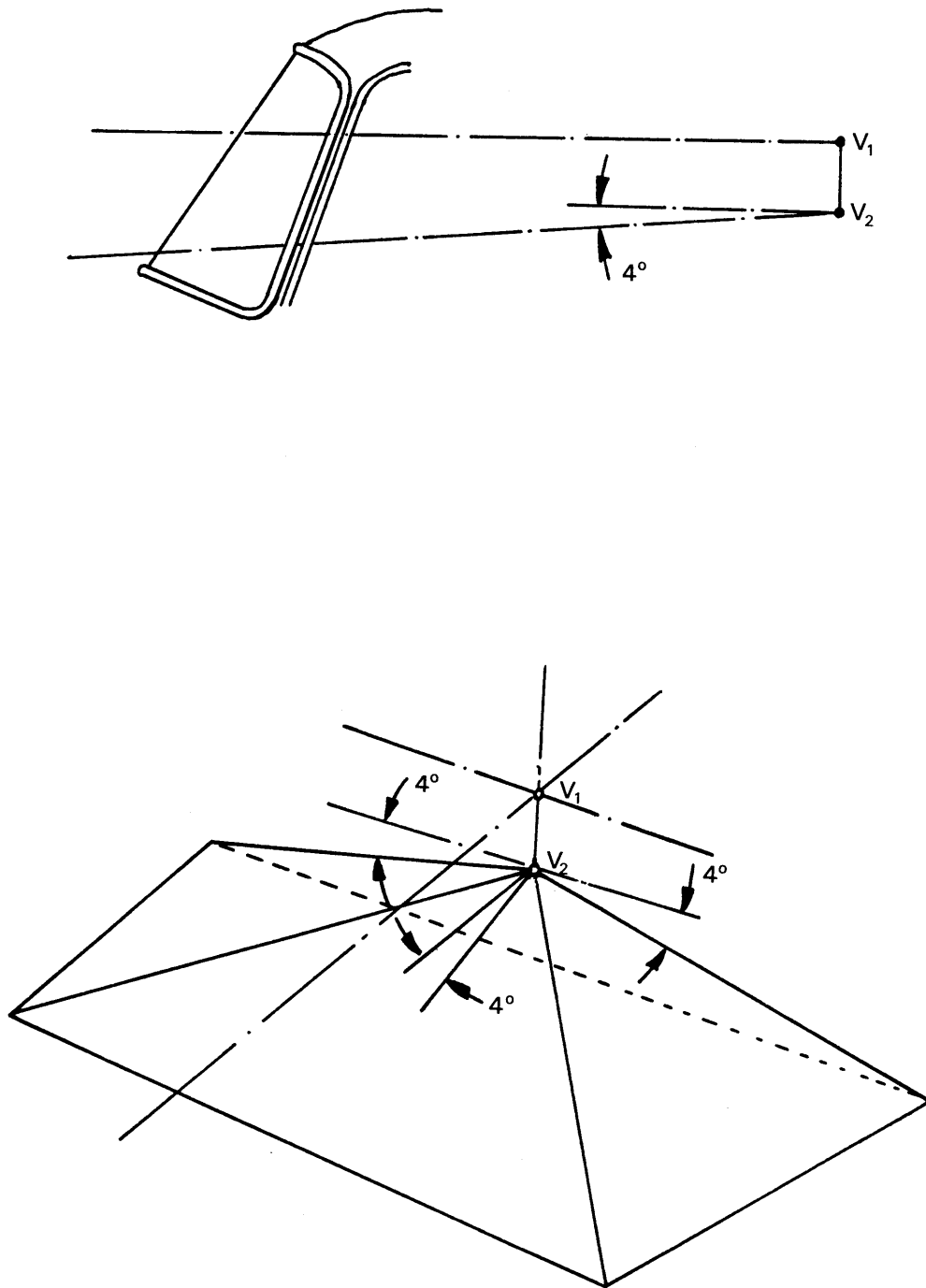

Figure 4

DIMENSIONAL DIAGRAM SHOWING RELATIVE POSITIONS OF E POINTS AND P POINTS

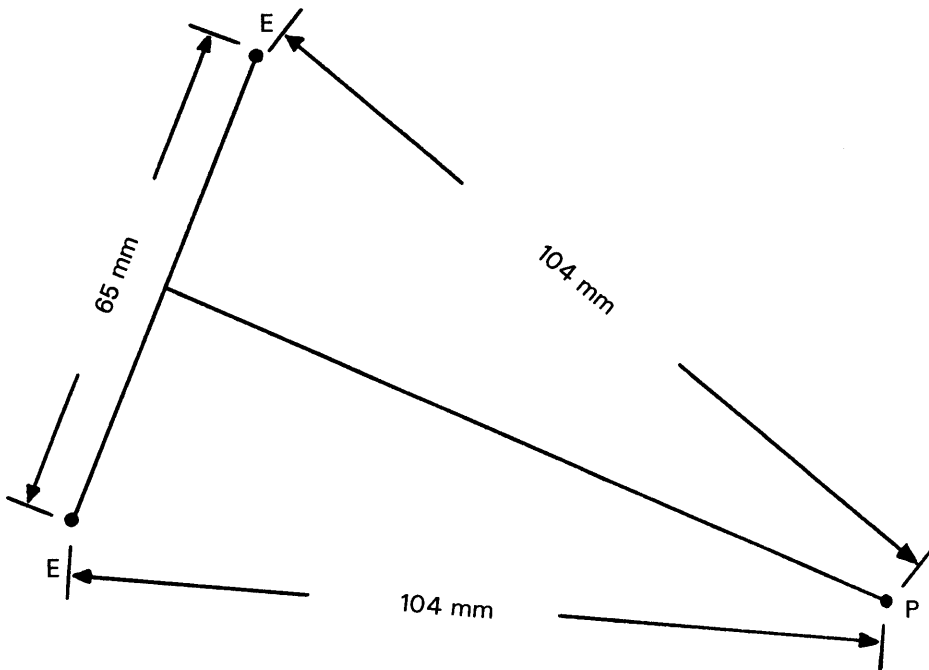

Figure 5

THREE-DIMENSIONAL REFERENCE GRID

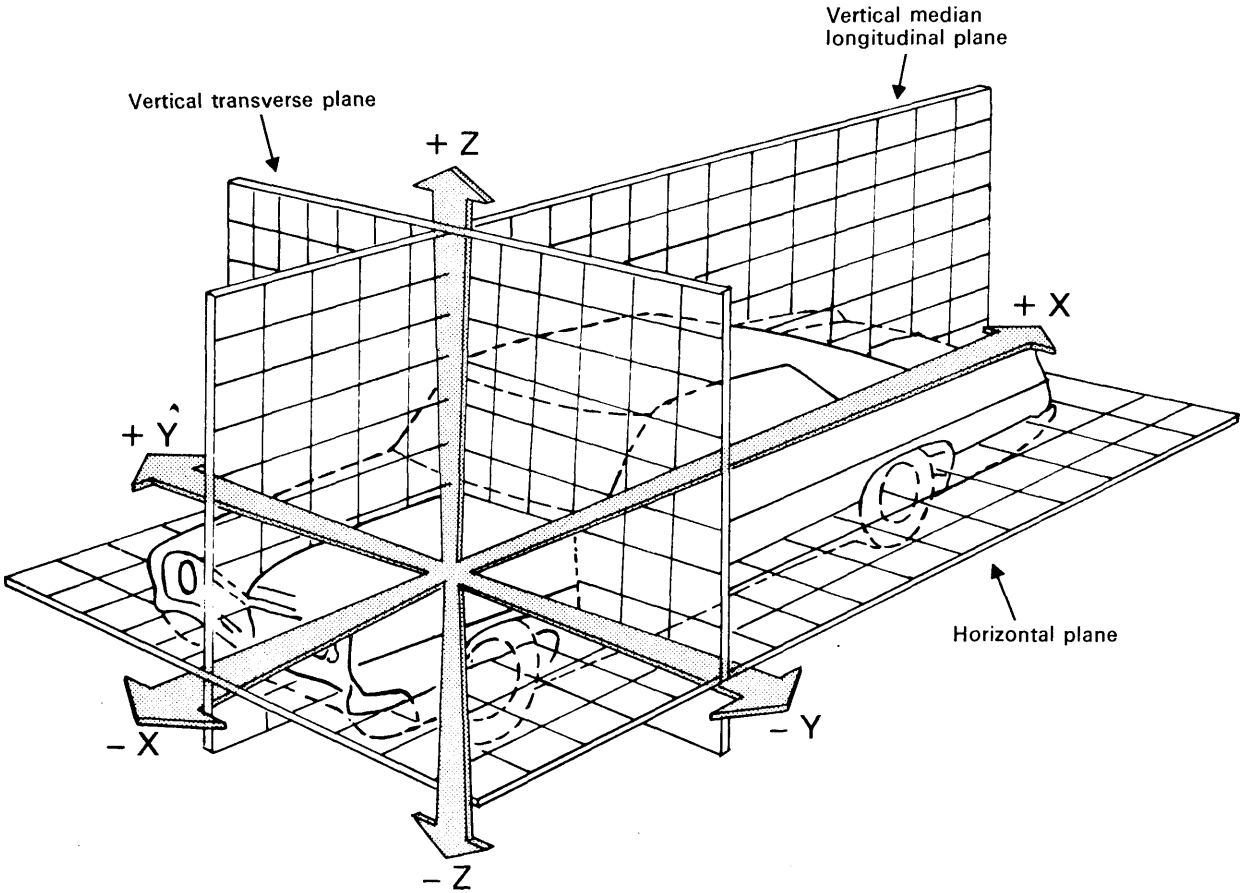
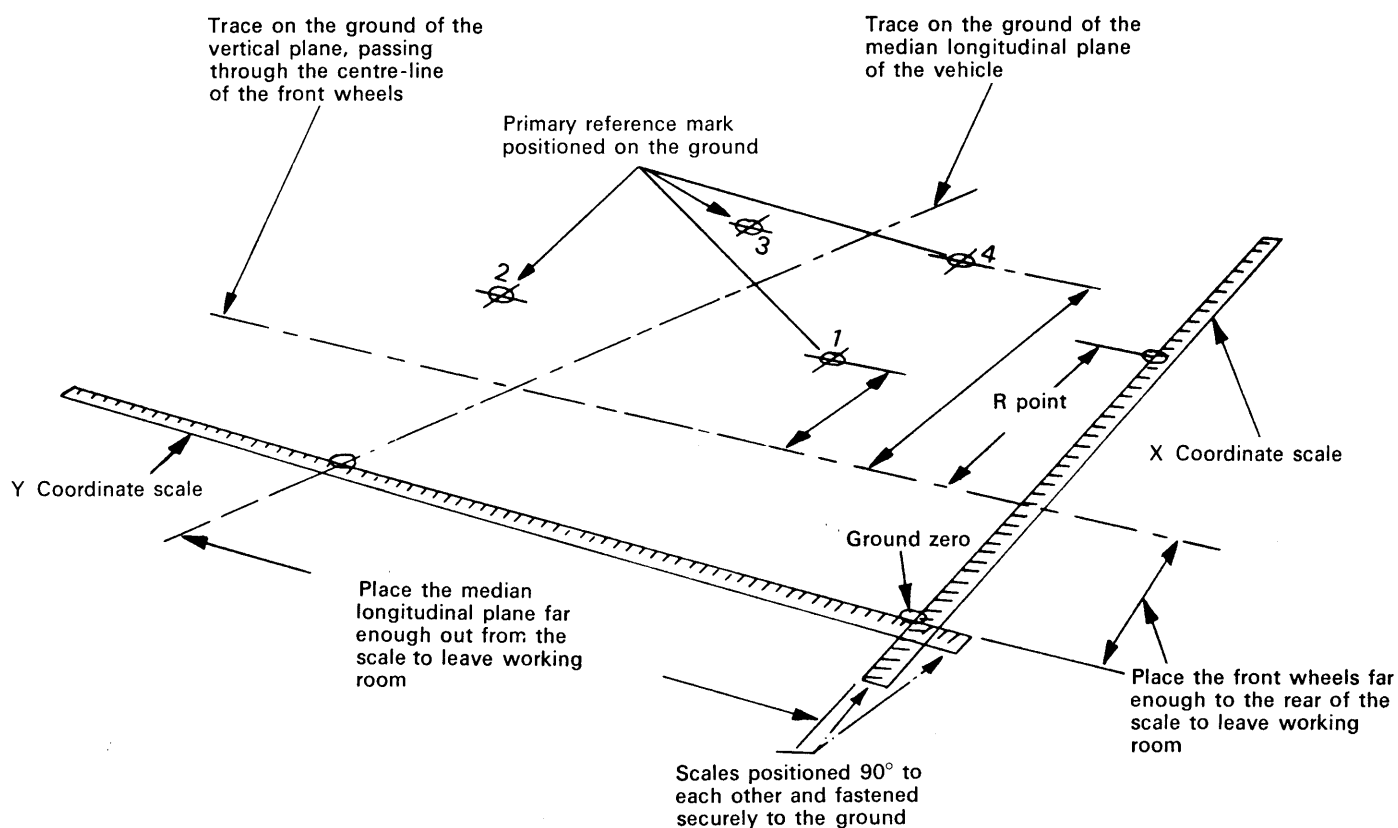

Figure 6

LEVEL WORK SPACE



ANNEX V

MODEL

(Maximum format: A 4 (210 x 297 mm))

Name of administration

ANNEX TO THE EEC VEHICLE TYPE-APPROVAL CERTIFICATE WITH REGARD TO THE DRIVER'S FIELD OF VISION

(Article 4 (2) and Article 10 of the Council Directive 70/156/EEC of 6 February 1970 on the approximation of the laws of the Member States relating to the type-approval of motor vehicles and their trailers)

- EEC type-approval No
- 1. Trade name or mark of the vehicle
- 2. Vehicle type
- 3. Manufacturer's name and address
- 4. Where applicable, name and address of manufacturer's authorized representative
- 5. Brief description of the vehicle
- 6. Identification data for R point of driver's designated seating position in relation to position of primary reference marks
- 7. Identifications, sites and relative positions of primary reference marks
- 8. Vehicle submitted for type-approval on
- 9. Technical service conducting type-approval tests
- 10. Date of report issued by that service
- 11. Number of report issued by that service
- 12. Type-approval in respect of the driver's field of vision is granted/refused ⁽¹⁾
- 13. Place
- 14. Date
- 15. Signature
- 16. The following documents, bearing the type-approval number shown above, are annexed to this certificate:
 - dimensional drawings
 - exploded view of photograph(s) of the passenger compartment
- 17. Remarks

⁽¹⁾ Delete as applicable.