

COUNCIL DIRECTIVE

of 21 December 1977

on the approximation of the laws of the Member States relating to the interior fittings of motor vehicles (identification of controls, tell-tales and indicators)

(78/316/EEC)

THE COUNCIL OF THE EUROPEAN COMMUNITIES,

HAS ADOPTED THIS DIRECTIVE:

Having regard to the Treaty establishing the European Economic Community, and in particular Article 100 thereof,

Having regard to the proposal from the Commission,

Having regard to the opinion of the European Parliament ⁽¹⁾,

Having regard to the opinion of the Economic and Social Committee ⁽²⁾,

Whereas the technical requirements which motor vehicles must satisfy pursuant to national laws relate *inter alia* to the identification of controls, tell-tales and indicators;

Whereas these requirements differ from one Member State to another; whereas it is therefore necessary that all Member States adopt the same requirements either in addition to or in place of their existing rules in order, in particular, to allow the EEC type-approval procedure, which was the subject of Council Directive 70/156/EEC of 6 February 1970 on the approximation of the laws of the Member States relating to the type-approval of motor vehicles and their trailers ⁽³⁾, as amended by Directive 78/315/EEC ⁽⁴⁾;

Whereas it is advisable to draft the technical requirements so that they have the same aim as the work being carried out on the subject in the UN Economic Commission for Europe and as certain technical requirements adopted by the International Organization for Standardization (ISO);

Whereas the approximation of national laws relating to motor vehicles entails reciprocal recognition by Member States of the checks carried out by each of them on the basis of the common requirements,

Article 1

For the purposes of this Directive, 'vehicle' means any motor vehicle intended for use on the road, having at least four wheels and a maximum design speed exceeding 25 km/h, with the exception of vehicles which run on rails, agricultural tractors and machinery and public works vehicles.

Article 2

No Member State may refuse to grant EEC type-approval or national type-approval of a vehicle on grounds relating to the identification of controls, tell-tales and indicators, if these satisfy the requirements laid down in Annexes I to IV.

Article 3

No Member State may refuse or prohibit the sale, registration, entry into service or use of any vehicle on grounds relating to the identification of controls, tell-tales and indicators if these satisfy the requirements laid down in Annexes I to IV.

Article 4

Any amendments necessary to adapt the requirements of Annexes I to V to technical progress shall be adopted in accordance with the procedure laid down in Article 13 of Directive 70/156/EEC.

Article 5

1. Member States shall bring into force the provisions necessary in order to comply with this Directive within 18 months of its notification and shall forthwith inform the Commission thereof.

⁽¹⁾ OJ No C 118, 16. 5. 1977, p. 33.

⁽²⁾ OJ No C 114, 11. 5. 1977, p. 10.

⁽³⁾ OJ No L 42, 23. 2. 1970, p. 1.

⁽⁴⁾ See page 1 of this Official Journal.

2. Member States shall ensure that the texts of the main provisions of national law which they adopt in the field covered by this Directive are communicated to the Commission.

Done at Brussels, 21 December 1977.

Article 6

This Directive is addressed to the Member States.

For the Council

The President

J. CHABERT

LIST OF ANNEXES

- Annex I: Scope, definitions, application for EEC type-approval, EEC type-approval, specifications (*)
- Annex II: Controls, tell-tales and indicators for which, when fitted, identification is mandatory, and symbols to be used for that purpose (*)
- Annex III: Controls, tell-tales and indicators for which, when fitted, identification is optional, and symbols which must be used if they are to be identified (*)
- Annex IV: Construction of the basic pattern for the symbols shown in Annexes II and III (*)
- Annex V: Annex to the EEC vehicle type-approval certificate with regard to the identification of controls, tell-tales and indicators.

(*) The technical requirements of this Annex are similar to those of the relevant UN Economic Commission for Europe draft regulation; the subdivisions have thus been observed. Where a section of the draft regulation has no counterpart in the Annexes to this Directive, the number is given in brackets for the record.

ANNEX I

SCOPE, DEFINITIONS, APPLICATION FOR EEC TYPE-APPROVAL, EEC TYPE-APPROVAL, SPECIFICATIONS

1. SCOPE

This Directive applies to motor vehicles with regard to the identification of manual controls, tell-tales and indicators.

2. DEFINITIONS

(2.1.)

2.2. Vehicle type

'Vehicle type' means motor vehicles which do not differ in respect of the internal arrangements which may affect the identification of symbols for controls, tell-tales and indicators.

2.3. Control

'Control' means that part of a device which enables the driver to bring about a change in the state or functioning of a vehicle.

2.4. On/off switch

'On/off switch' means a device by which the supply to an electrical circuit can be connected or cut off.

2.5. Selector switch

'Selector switch' means a device by which the supply of electric current can be transferred from one of two circuits to the other without any possibility of disconnection between the two positions.

2.6. Combined on/off-selector switch

'Combined on/off-selector switch' means a multi-function device which on first being actuated or put into position operates as an on/off switch and on each of the subsequent occasions when it is actuated or put into position operates as a selector switch.

2.7. Indicator

'Indicator' means a device which presents information on the functioning or situation of a system or part of a system, for example a fluid level.

2.8. Tell-tale

'Tell-tale' means an optical signal which indicates the actuation of a device, correct or defective functioning or condition, or failure to function.

2.9. Symbol

'Symbol' means a diagram identifying a control, a tell-tale or an indicator.

2.10. Master lighting switch

'Master lighting switch' means a switch connecting or cutting off the supply of current to the electrical circuits of the main/dipped-beam headlamps and lamp of the devices referred to in 3.11 of Annex I to Council Directive 76/756/EEC of 27 July 1976 on the approximation of the laws of the Member States relating to the installation of lighting and light-signalling devices on motor vehicles and their trailers ⁽¹⁾.

⁽¹⁾ OJ No L 262, 27. 9. 1976, p. 1.

- 2.11. **Battery-charging indicator**
'Battery-charging indicator' means a device showing whether the battery is being charged or not.
- 2.12. **Battery charging tell-tale**
'Battery charging tell-tale' means a signal which when alight indicates that the battery is not being charged.
- 2.13. **Fuel-level indicator**
'Fuel-level indicator' means a device which gives information on the amount of fuel in the tank.
- 2.14. **Fuel level tell-tale**
'Fuel level tell-tale' means a signal which when alight indicates that the fuel level is close to zero or that the vehicle is running on its fuel reserve.
- 2.15. **Engine coolant temperature indicator**
'Engine coolant temperature indicator' means a device which gives information on the temperature of the coolant.
- 2.16. **Engine coolant temperature tell-tale**
'Engine coolant temperature tell-tale' means a signal which when alight indicates that the temperature of the engine coolant is above the normal running temperature prescribed by the manufacturer.
- 2.17. **Oil pressure indicator**
'Oil pressure indicator' means a device which gives information on the pressure of the oil in the engine lubrication circuit.
- 2.18. **Oil pressure tell-tale**
'Oil pressure tell-tale' means a signal which when alight indicates that the oil pressure in the engine lubrication circuit is below the normal operating limit prescribed by the manufacturer.
- 2.19. **Safety belt tell-tale**
'Safety belt tell-tale' means a signal which when alight indicates that the buckle of the belt of at least one of the occupied seats is not locked.
- 2.20. **Parking brake circuit-closed tell-tale**
'Parking brake circuit-closed tell-tale' means a signal which when alight indicates that the parking brake control has not been released.

3. APPLICATION FOR EEC TYPE-APPROVAL

- 3.1. The application for type-approval of a vehicle type with regard to the identification of controls, tell-tales and indicators shall be submitted by the vehicle manufacturer or by his authorized representative.
- 3.2. It must be accompanied by the following:
- 3.2.1. drawings (three copies), on an appropriate scale and in sufficient detail, of the parts of the vehicle to which the requirements of this Directive apply and of the symbols referred to in section 5.
- 3.3. A vehicle representative of the type to be approved or such part or parts of the vehicle as are considered to be necessary for carrying out the checks and tests prescribed by this Directive must be submitted to the technical service responsible for conducting the type-approval tests.

4. EEC TYPE-APPROVAL

(4.1.)

(4.2.)

4.3. A certificate conforming to the model shown in Annex V shall be attached to the EEC type-approval certificate.

(4.4.)

(4.5.)

(4.6.)

(4.7.)

(4.8.)

5. SPECIFICATIONS**5.1. General specifications**

5.1.1. The controls, tell-tales and indicators listed in Annex II must be identified by symbols. The symbols must be in conformity with those indicated in the said Annex.

5.1.2. If symbols are used for identifying the controls and tell-tales listed in Annex III, such symbols must be in conformity with those indicated in the said Annex.

5.1.3. Symbols other than those shown in Annexes II and III may be used for other purposes, provided that there is no danger of confusion with those shown in the said Annexes.

5.1.4. 'Conformity' means having proportional dimensional characteristics.

5.2. Characteristics of the symbols

5.2.1. The symbols prescribed in 5.1.1 shall be identifiable, from his seat, by a driver with normal eyesight.

5.2.2. The symbols prescribed in 5.1.1 and 5.1.2 must be on or close to the controls, tell-tales and indicators.

5.2.3. The symbols must stand out clearly against the background, being either light on a dark background or dark on a light background.

5.2.4. The colours used for tell-tales must be those prescribed in Annex II.

(6.)

(7.)

(8.)

(9.)

ANNEX II

CONTROLS, TELL-TALES AND INDICATORS FOR WHICH, WHEN FITTED, IDENTIFICATION IS MANDATORY, AND SYMBOLS TO BE USED FOR THAT PURPOSE

Notes

- (a) The interior of the symbol may be entirely in a dark colour.
- (b) If the tell-tales for the left and right direction indicators are separate, the two arrows of the symbol may also be used separately.
- (c) The dark part of this symbol may be replaced by its outline, in which case the portion shown here as white must be entirely in a dark colour.
- (d) If the control is not separate, it may be identified by one or more symbols indicating its different functions.
- (e) If the indicator and tell-tale are combined, one symbol may be used for both.

Figure 1

Master lighting switch and circuit-closed tell-tale ⁽¹⁾ or combined on/off-selector switch for lighting

Standard symbol

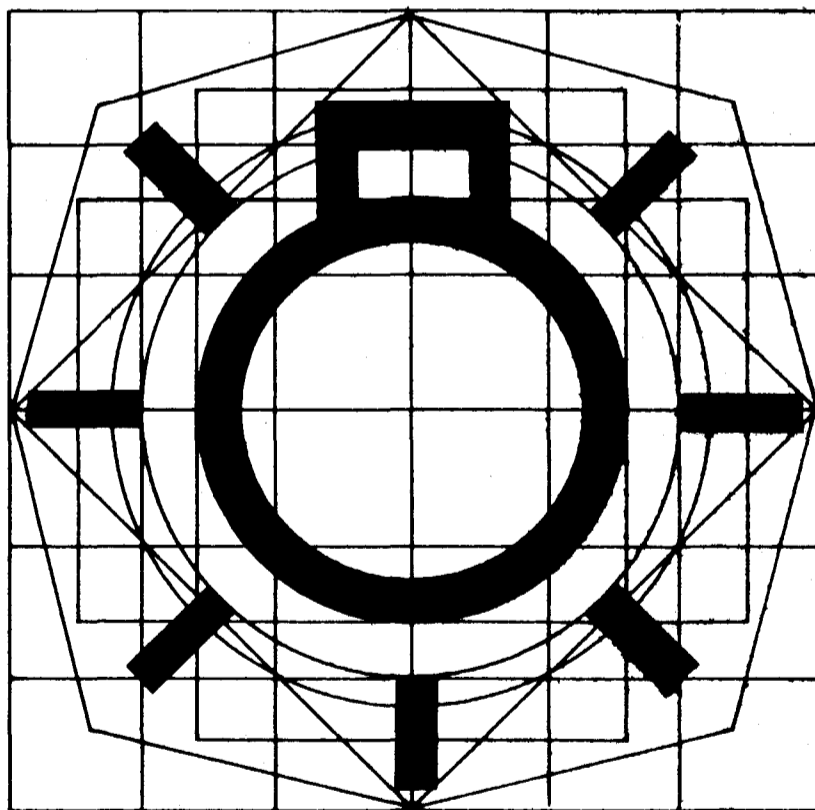

Colour of tell-tale light: green

⁽¹⁾ This tell-tale may not act as the tell-tale for the position (side) lamps.

Figure 2

Main-beam headlamp control, if separate (d), and circuit-closed tell-tale

Standard symbol

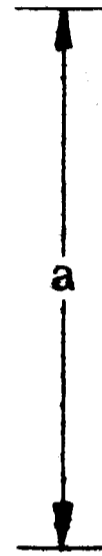
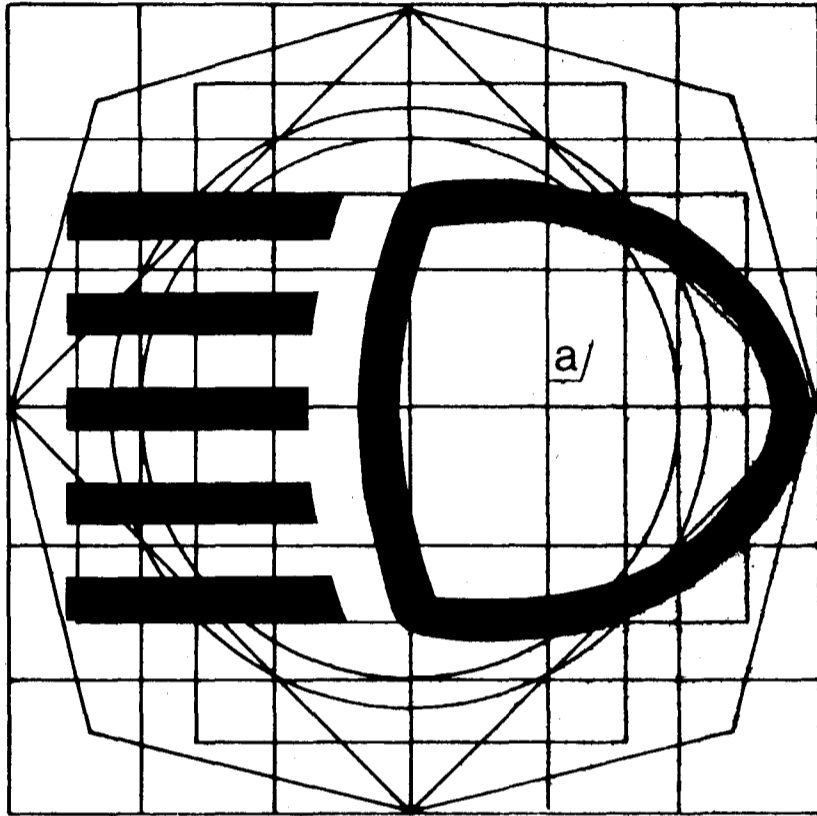

Colour of tell-tale light: blue

Figure 3

Dipped-beam headlamp control, if separate (d), and circuit-closed tell-tale

Standard symbol

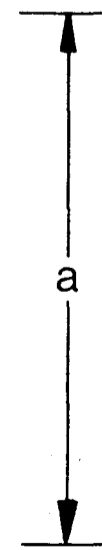
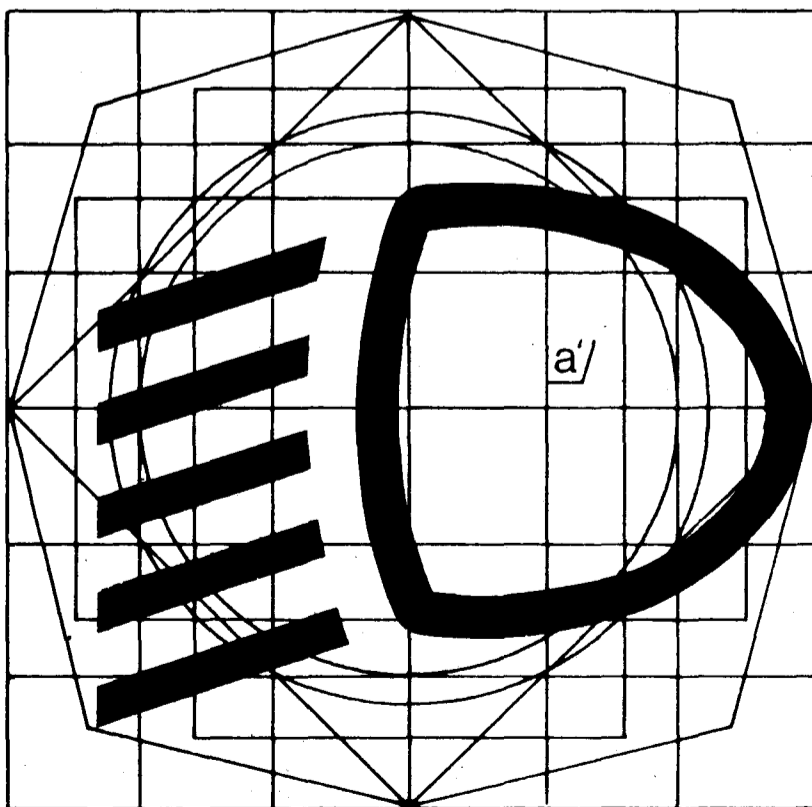

Colour of tell-tale light: green

Figure 4

Front fog-lamp control and circuit-closed tell-tale

Standard symbol

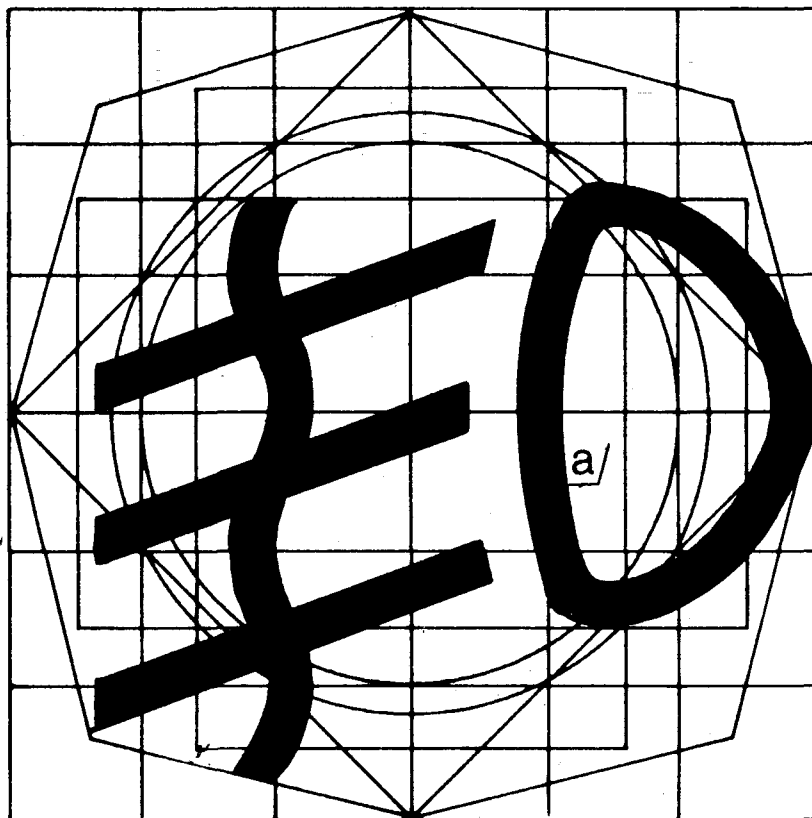

Colour of tell-tale light: green

Figure 5

Separate reversing lamp control (where fitted) and circuit-closed tell-tale

Standard symbol

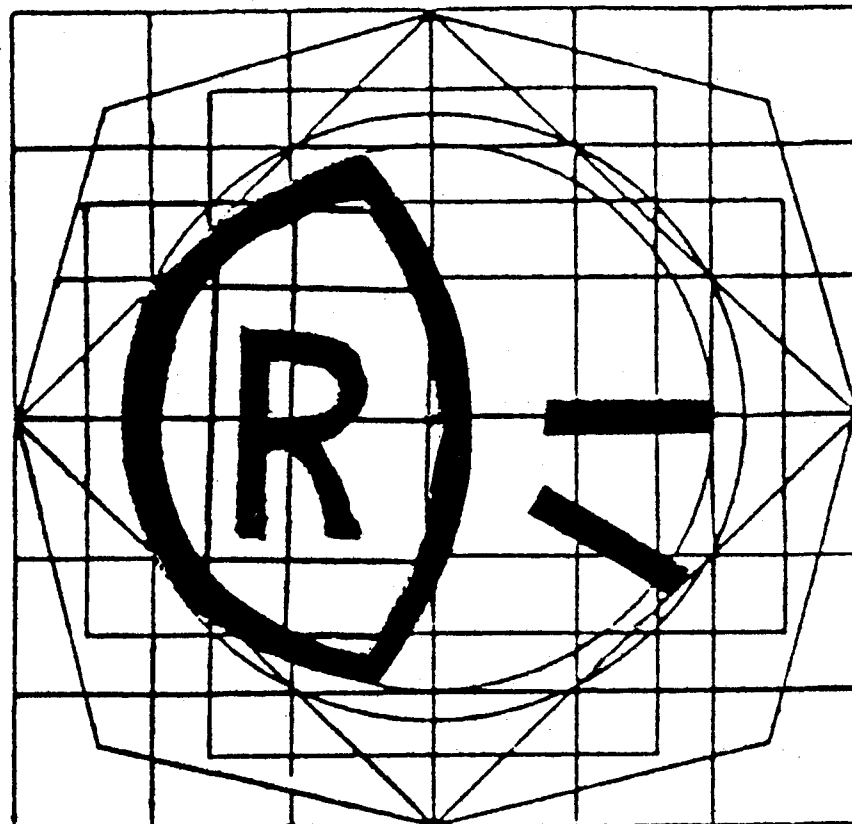

Colour of tell-tale light: green

Figure 6

Direction-indicator lamp control and operational tell-tale (b)

Standard symbol

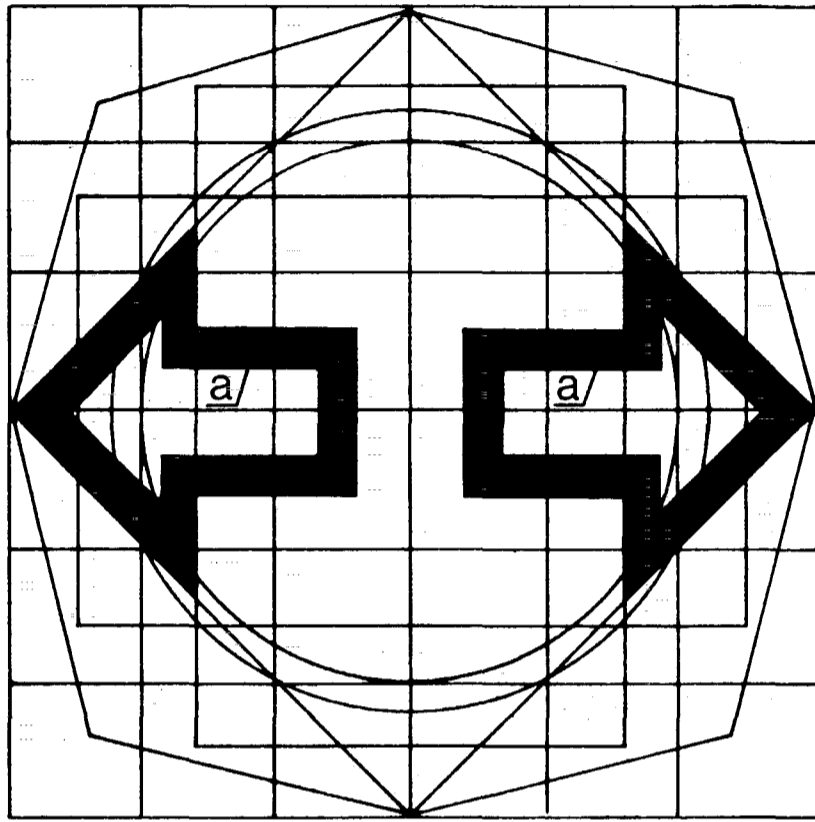

Colour of tell-tale light: green

Figure 7

Hazard-warning control and circuit-closed tell-tale

Standard symbol

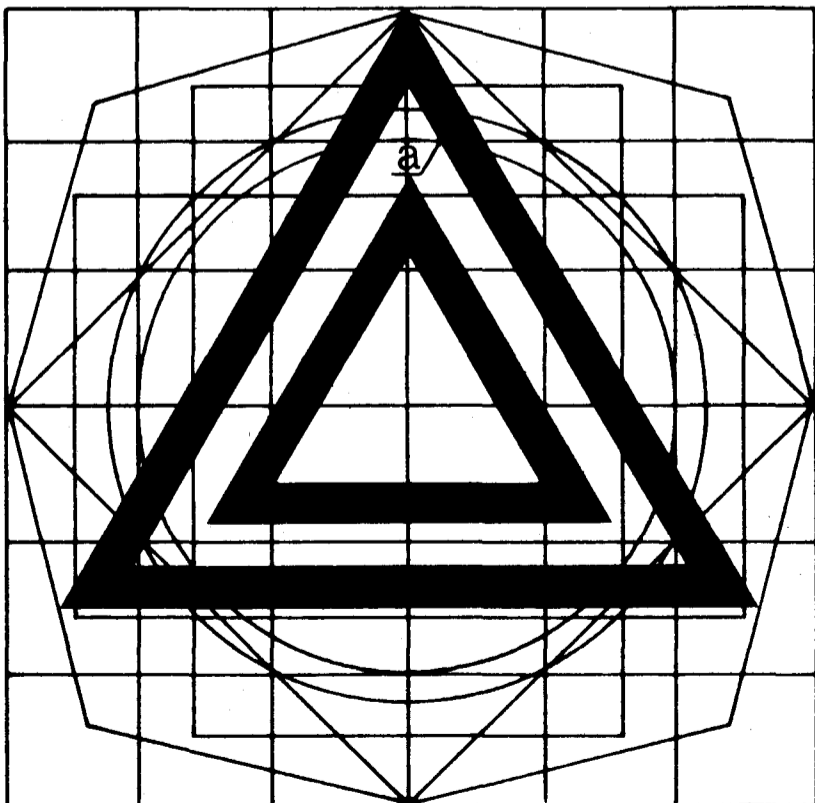

Colour of tell-tale light: red

Figure 8

Stop lamp tell-tale

If fitted, its function must be performed by the braking system defective operation tell-tale, which is shown in figure 28.

Figure 9

Position (side) lamps control, if separate (d), and position (side) lamps circuit-closed tell-tale

Standard symbol

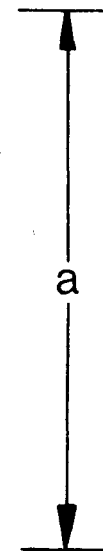
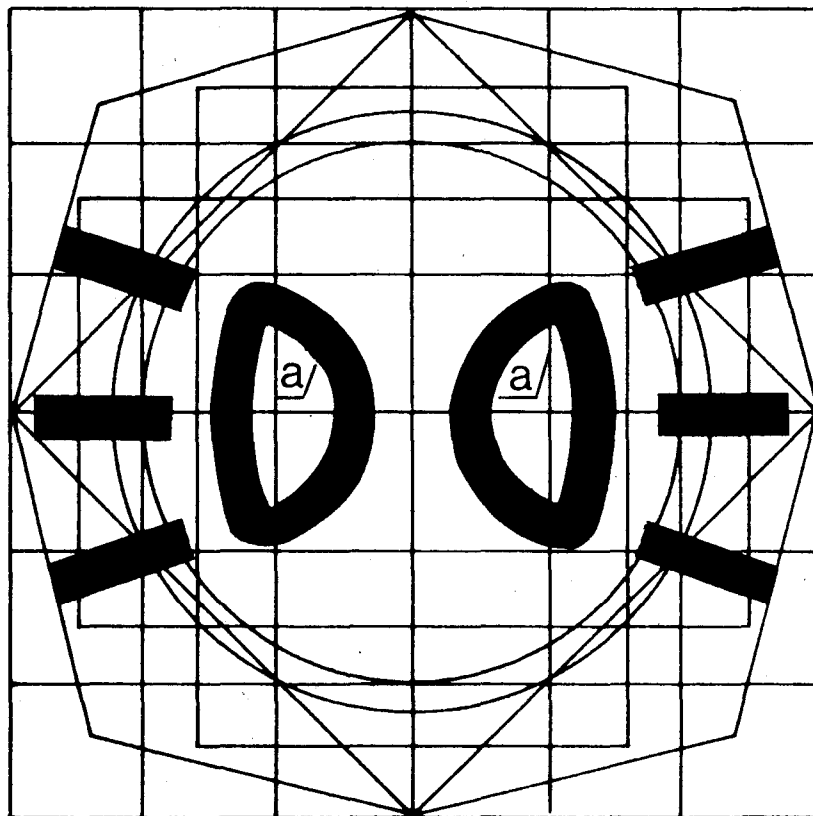

Colour of tell-tale light: green

Figure 10

Rear fog-lamp(s) control and circuit-closed tell-tale

Standard symbol

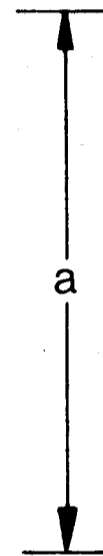
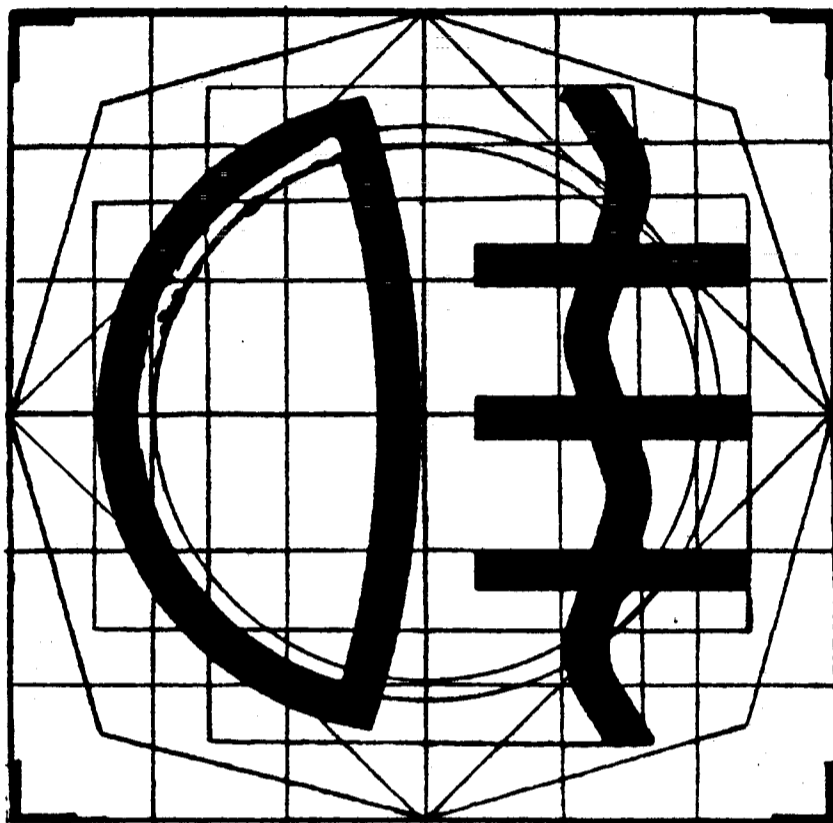

Colour of tell-tale light: amber

Figure 11

Parking lamp(s) control, if separate (d), and circuit-closed tell-tale

Standard symbol

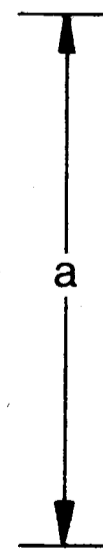
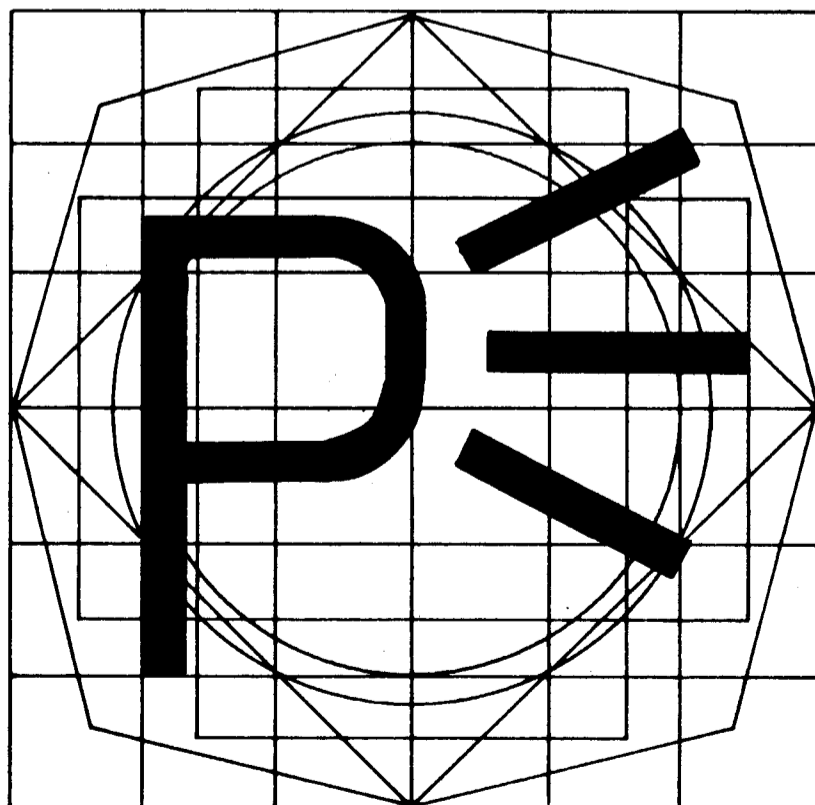

Colour of tell-tale light: green

Figure 12

Windscreen-wiper control

Standard symbol

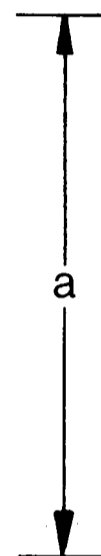
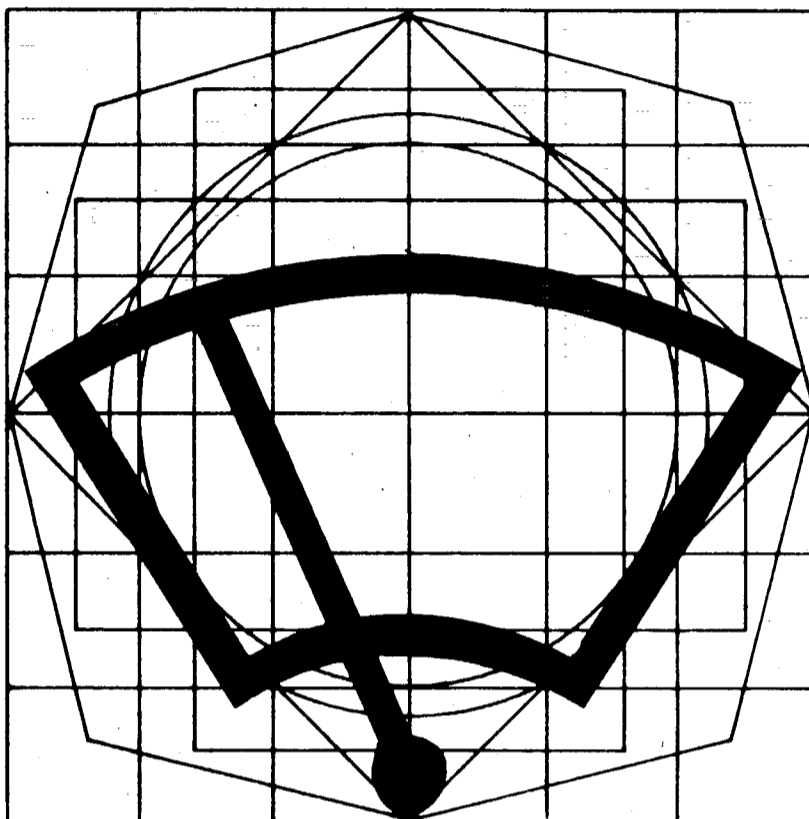

Figure 13

Windscreen-washer control

Standard symbol

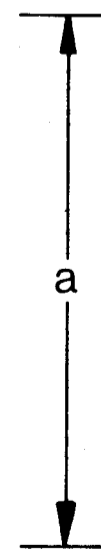
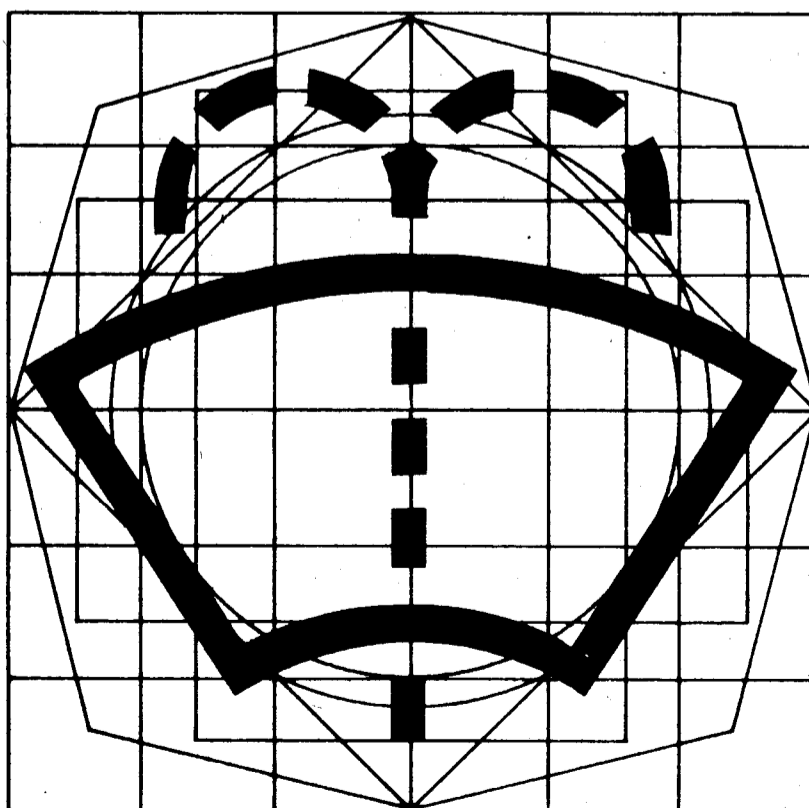

Figure 14

Combined windscreen-wiper and windscreen-washer control

Standard symbol

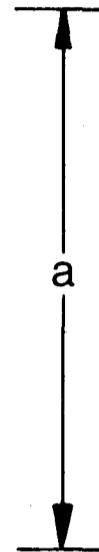
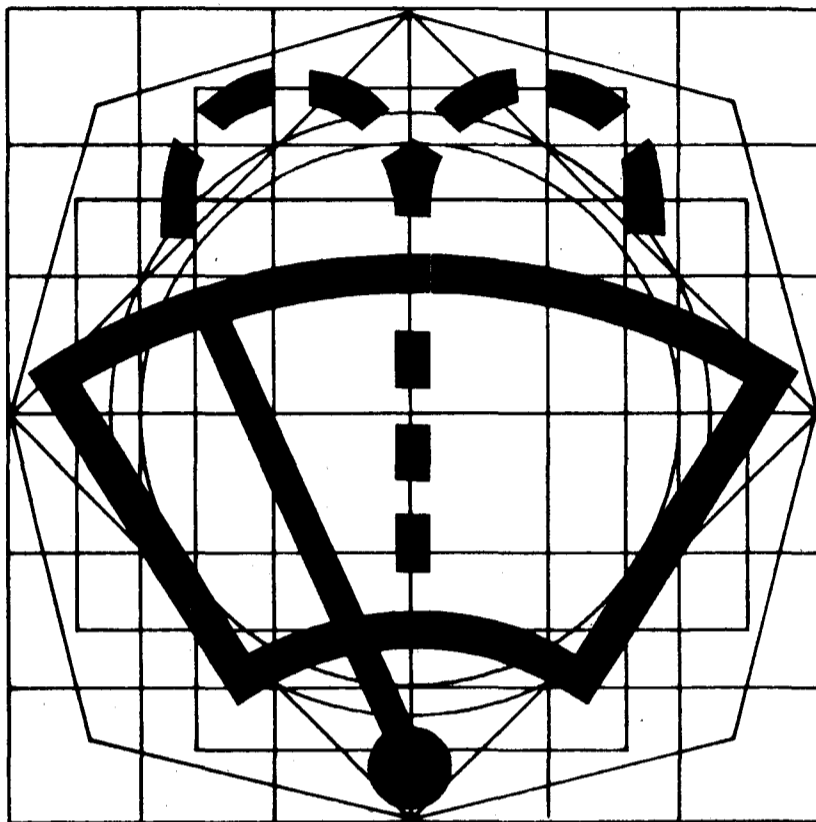
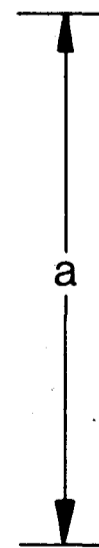
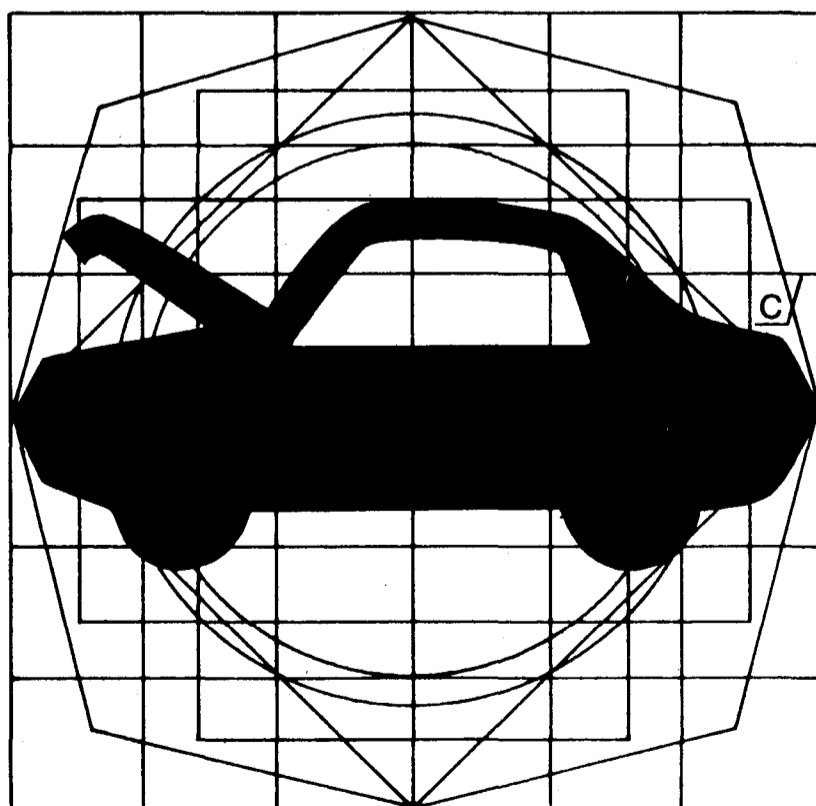

Figure 15

Front bonnet opener control ⁽¹⁾

Standard symbol



⁽¹⁾ If the vehicle manufacturer so wishes, section 5.1.1 of Annex I shall not apply where this control is not within the driver's field of vision from the normal driving position.

Figure 16

Fan (warm air/cold air) control

Standard symbol

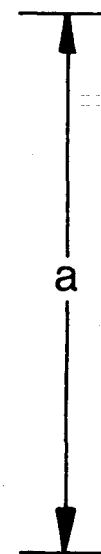
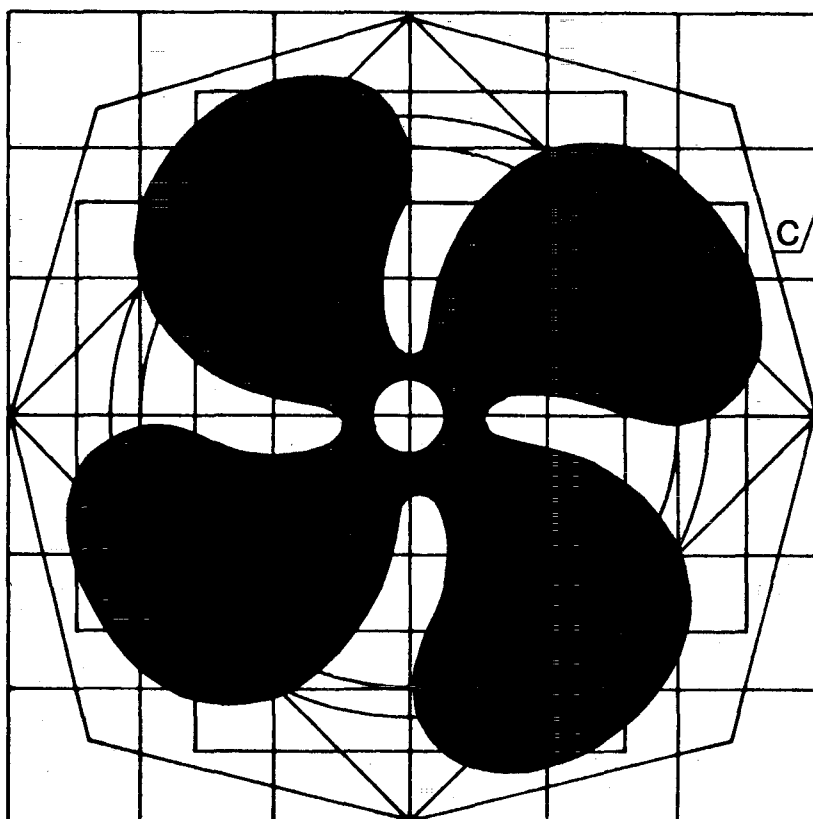
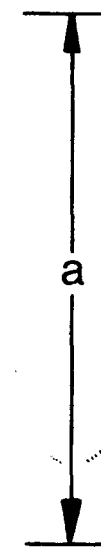
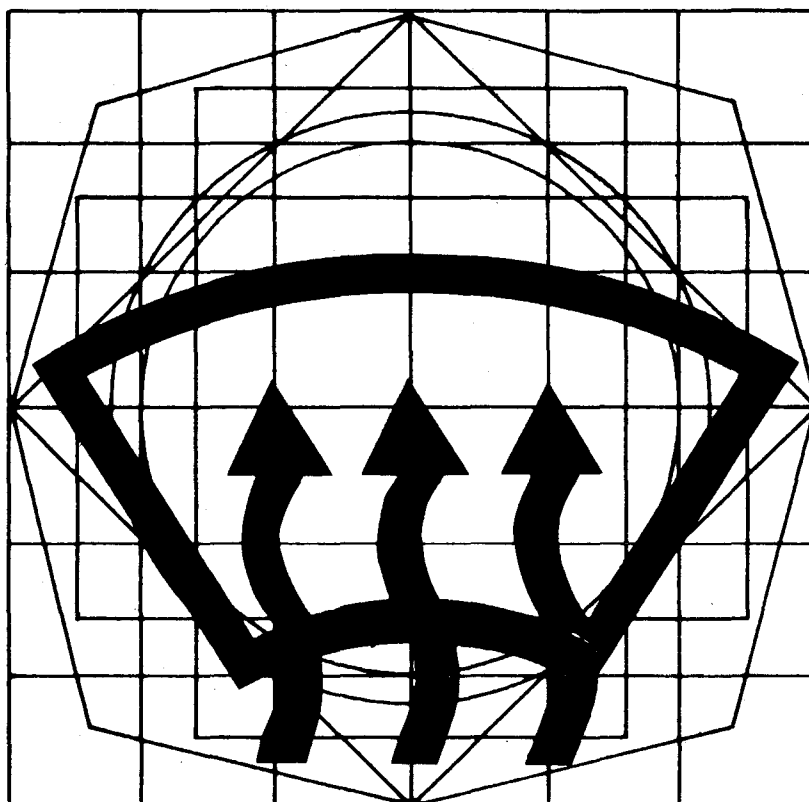

Figure 17

Windscreen defroster and demister control, if separate, and tell-tale

Standard symbol



Colour of tell-tale light: amber

Figure 18

Rear-window defroster and demister control, if separate, and tell-tale

Standard symbol

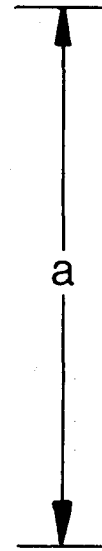
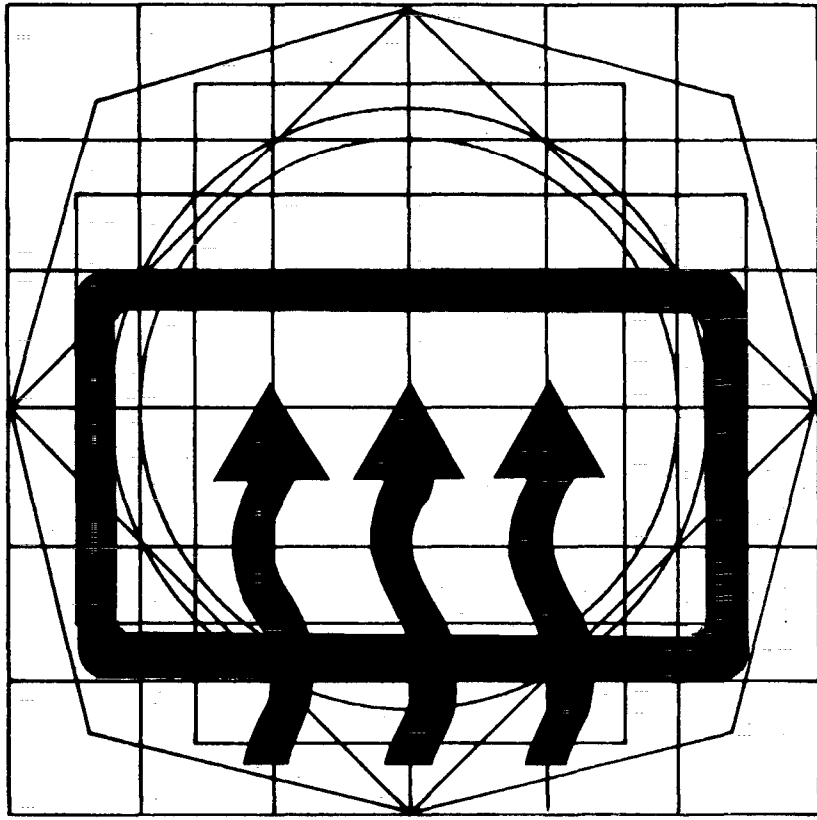

Colour of tell-tale light: amber

Figure 19

Cold-starting device control

Standard symbol

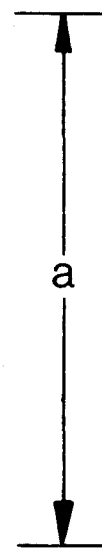
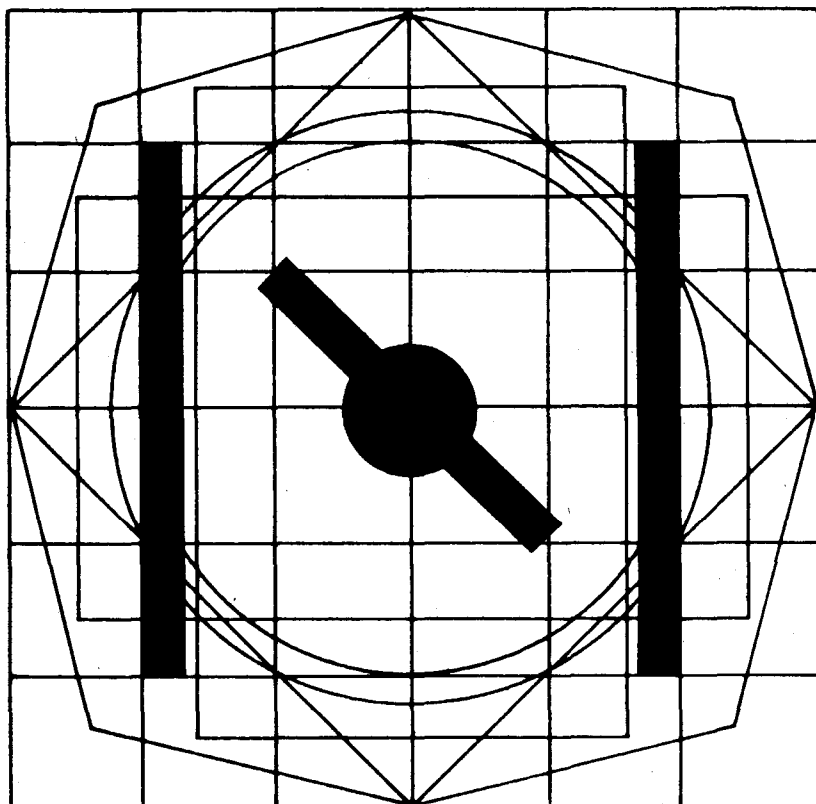

Colour of tell-tale light: amber

Figure 20

Hand-accelerator control

Standard symbol

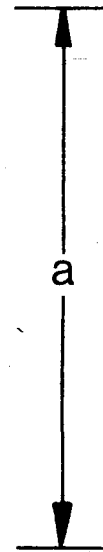
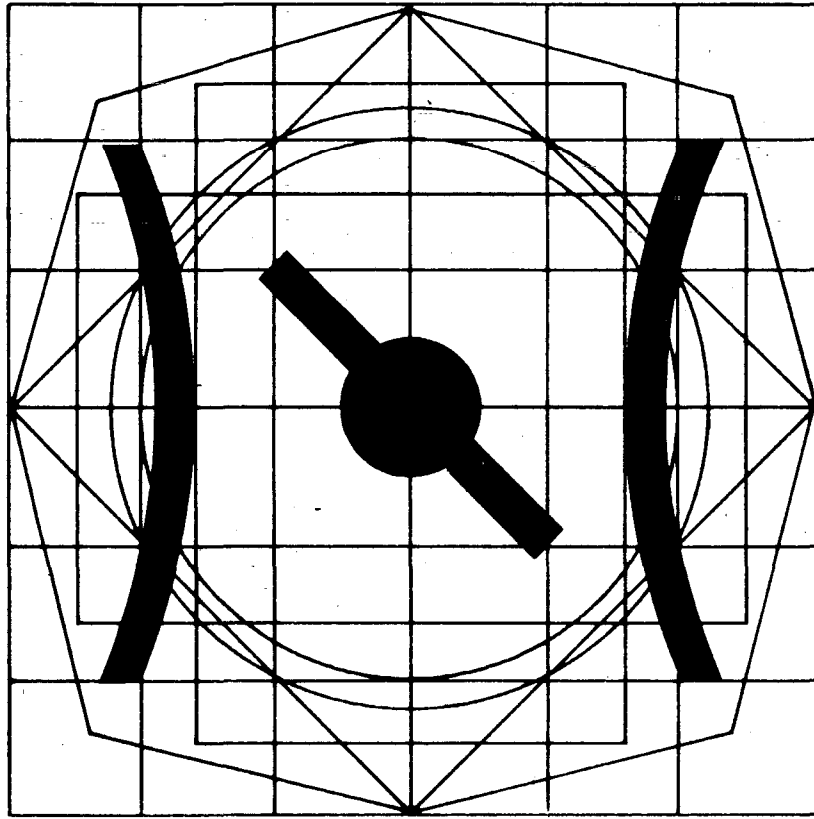
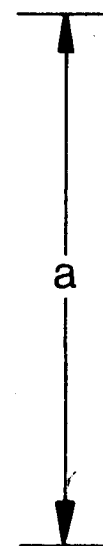
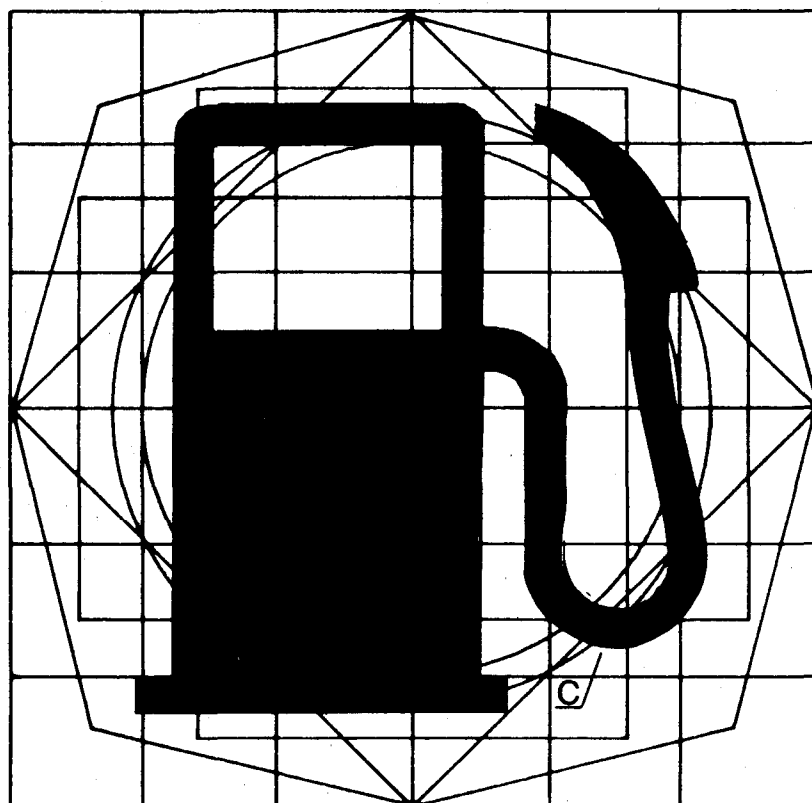

Figure 21

Fuel-level indicator and tell-tale

Standard symbol



Colour of tell-tale light: amber

Figure 22

Battery-charging indicator and tell-tale

Standard symbol

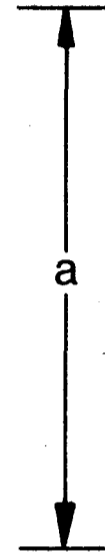
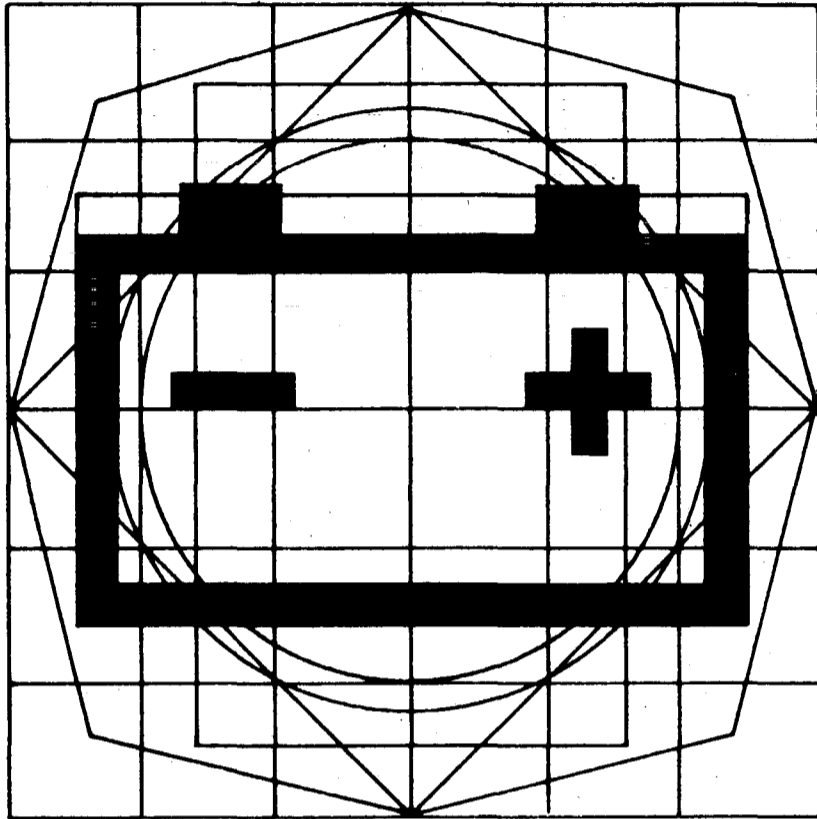

Colour of tell-tale light: red

Figure 23

(Diesel) engine cut-off control, if installed on dashboard

Standard symbol

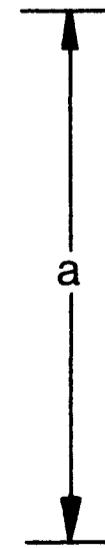
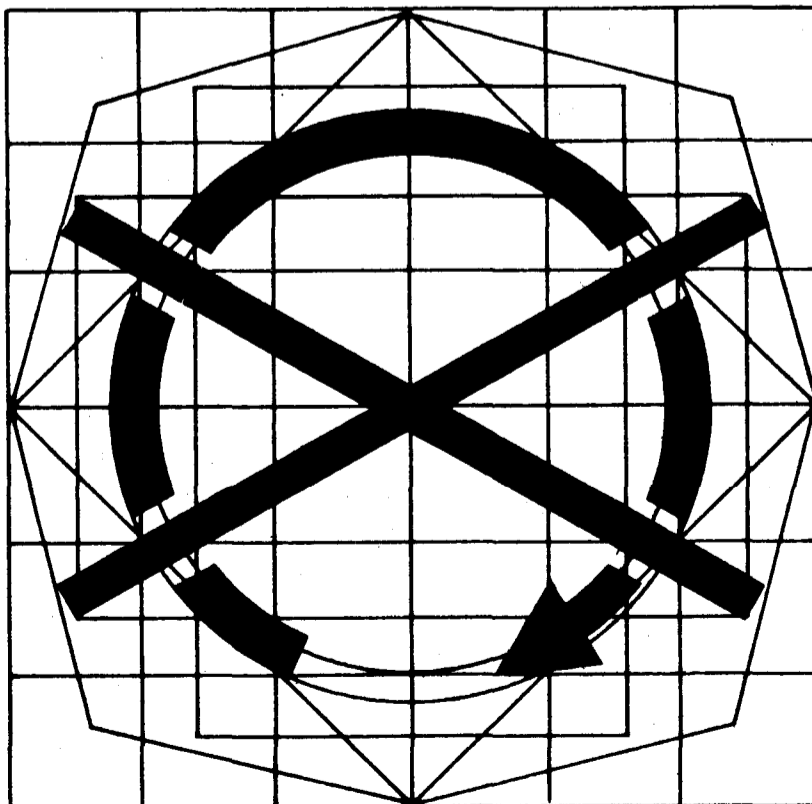
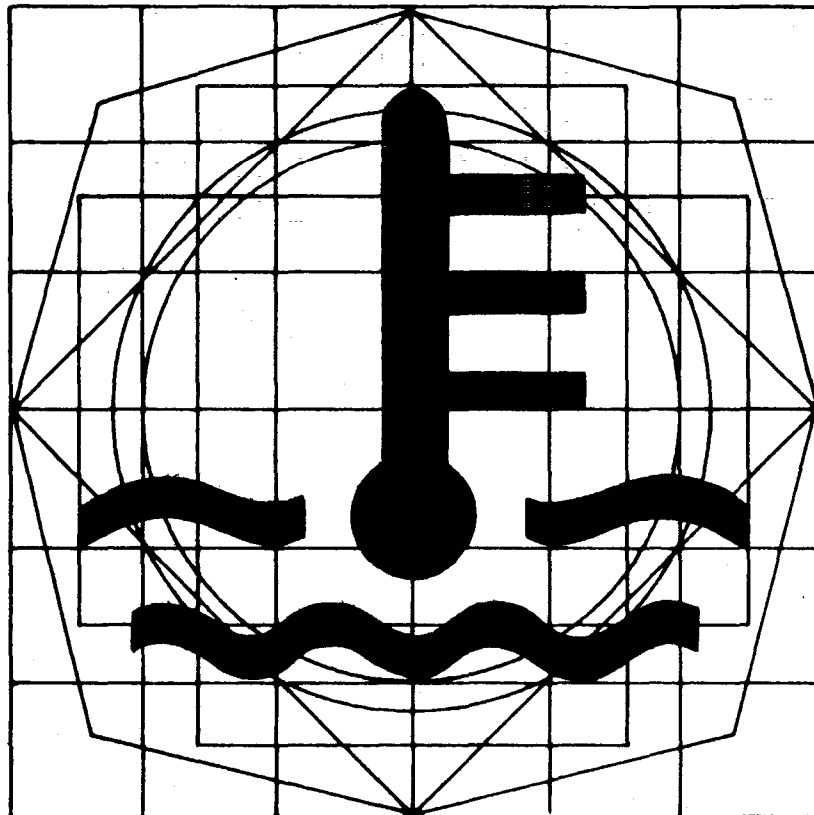

Figure 24

Engine coolant temperature indicator and tell-tale

Standard symbol



Colour of tell-tale light: red

Figure 25

Oil pressure indicator and tell-tale

Standard symbol

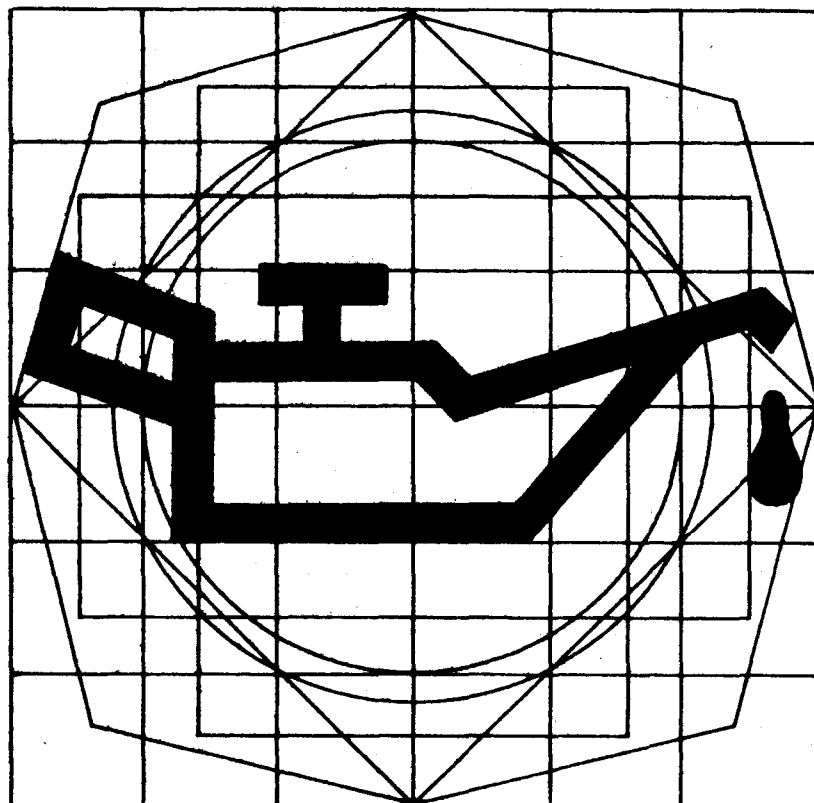

Colour of tell-tale light: red

Figure 26

Safety belt tell-tale

Standard symbol

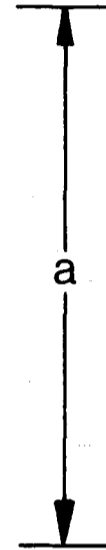
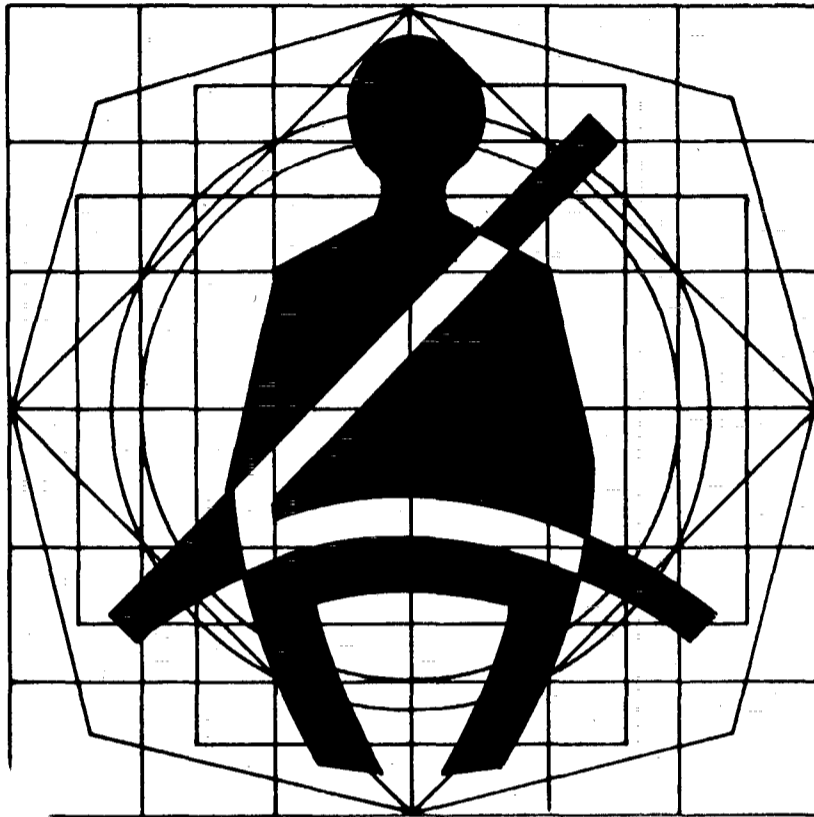

Colour of tell-tale light: red

Figure 27

Headlamp cleaning device hand-control

Standard symbol

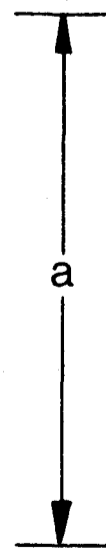
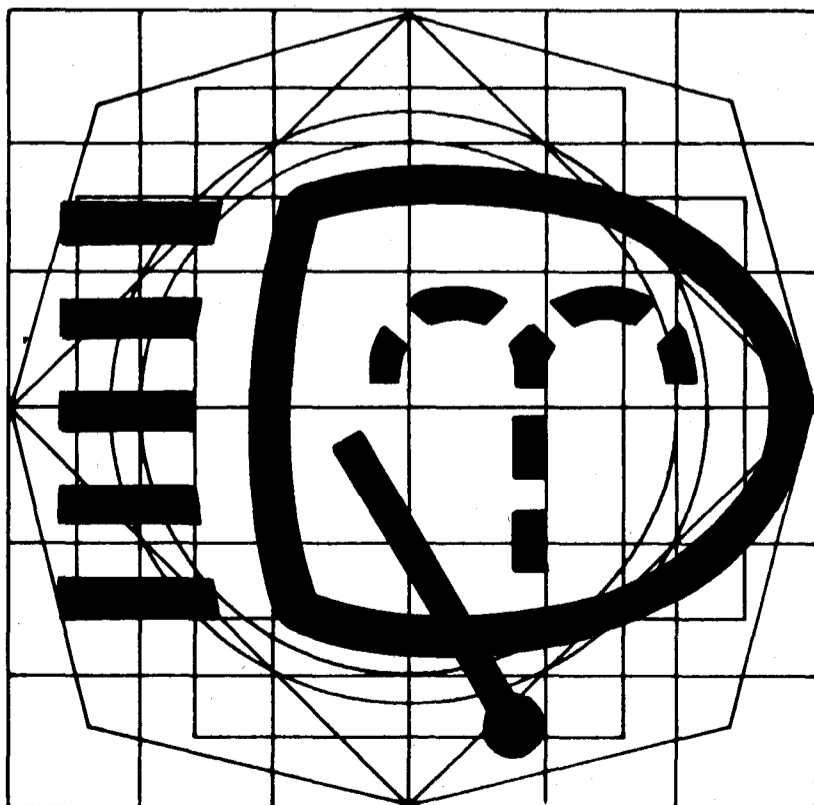
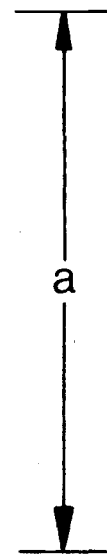
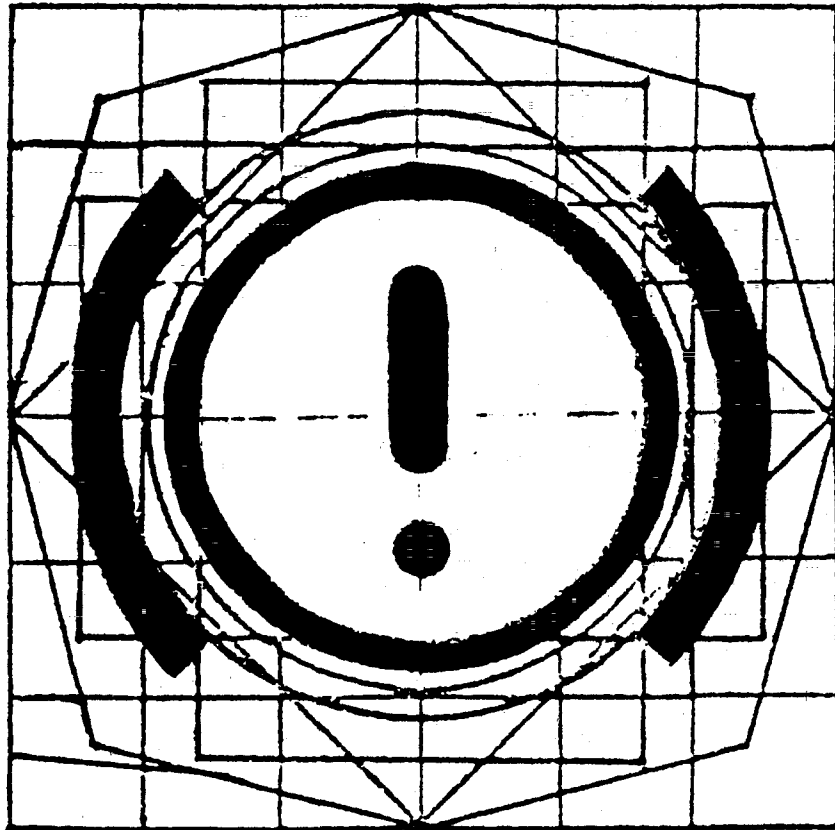

Figure 28

Braking system defective operation tell-tale

Standard symbol



Colour of tell-tale light: red

Figure 29

Parking brake circuit-closed tell-tale

Standard symbol

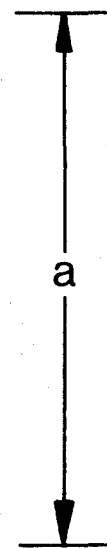
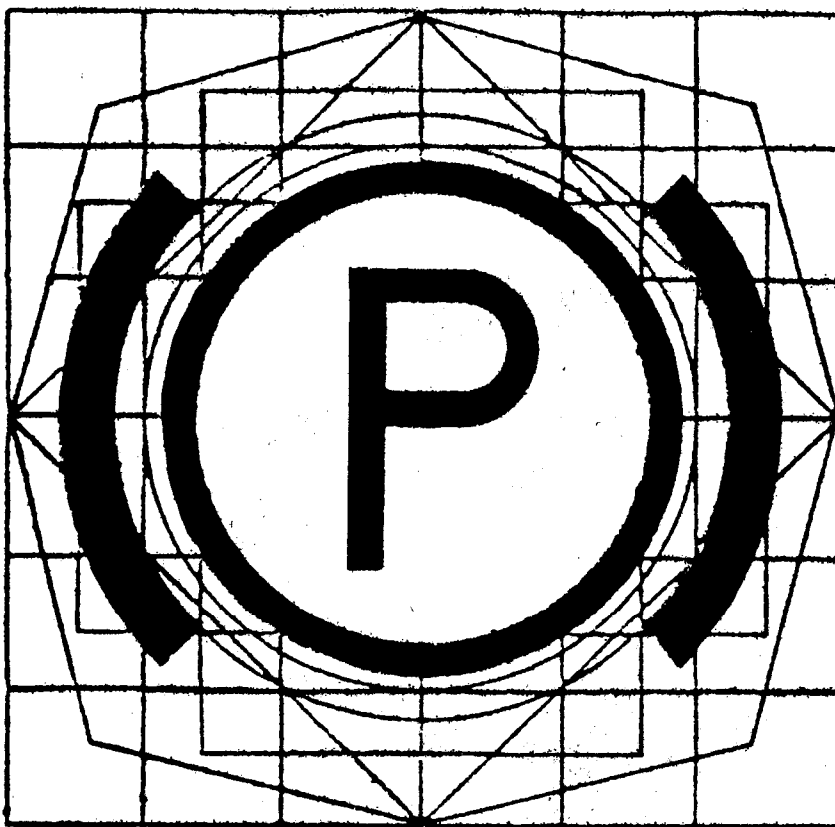

Colour of tell-tale light: red

ANNEX III

CONTROLS, TELL-TALES AND INDICATORS FOR WHICH, WHEN FITTED, IDENTIFICATION IS OPTIONAL, AND SYMBOLS WHICH MUST BE USED IF THEY ARE TO BE IDENTIFIED

Note

See note (c) in Annex II.

Figure 1

Rear-compartment closure release control

Standard symbol

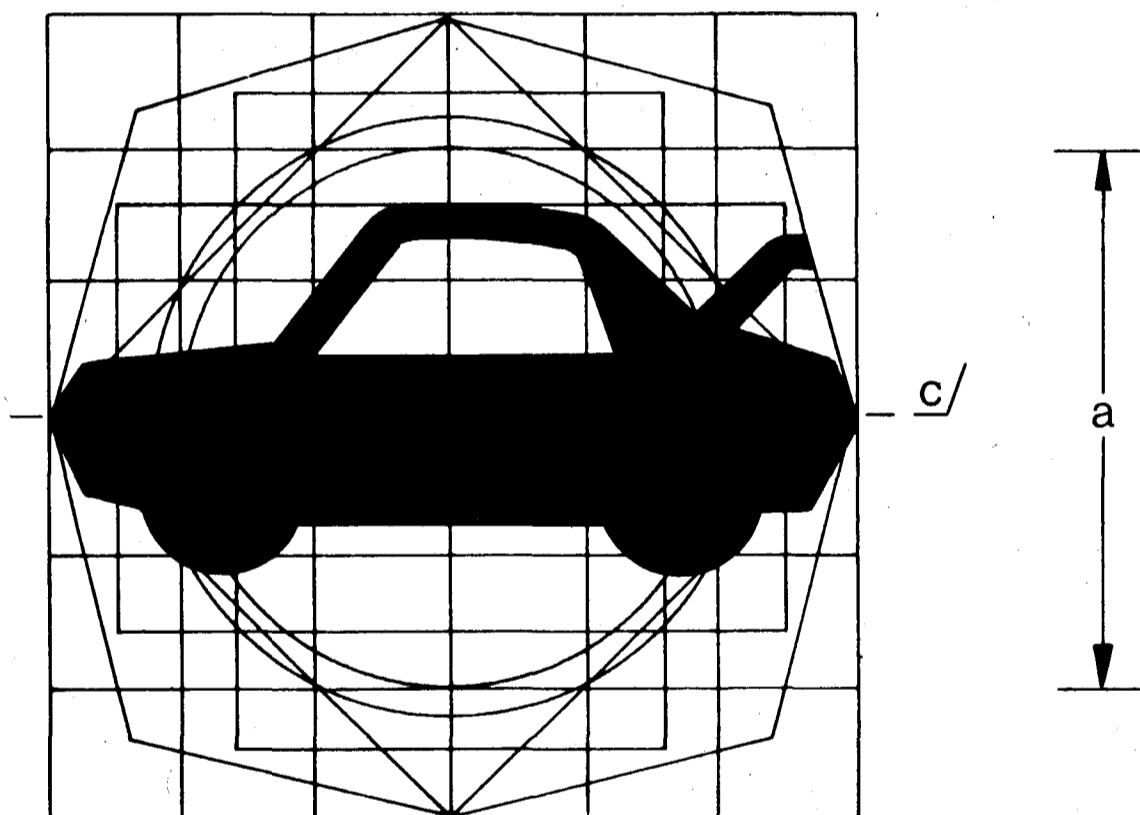
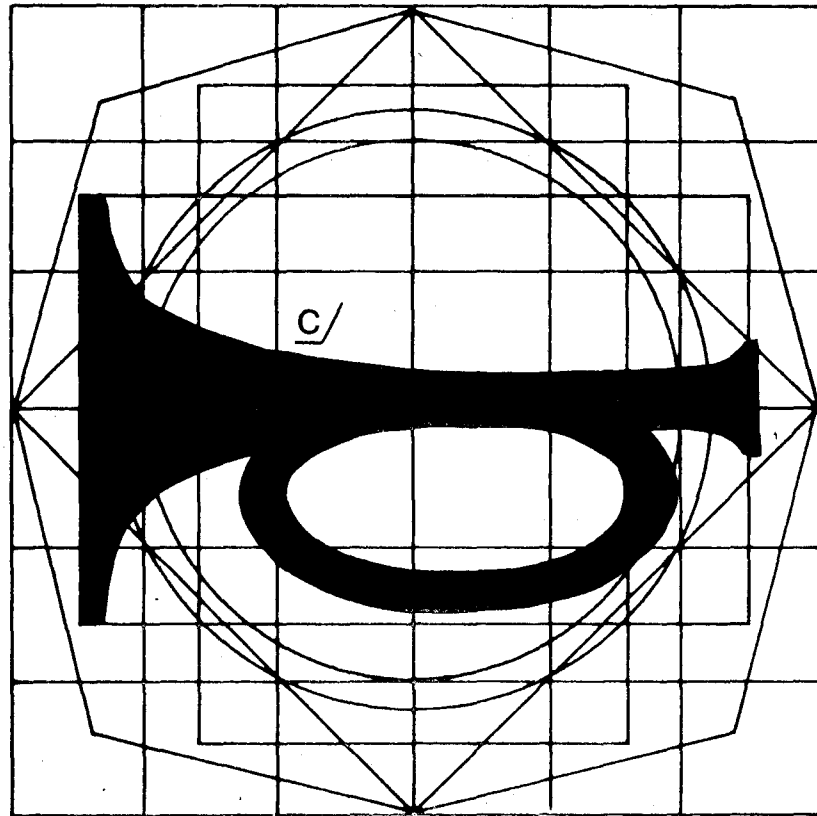

Figure 2

Audible warning device control

Standard symbol



ANNEX IV

CONSTRUCTION OF THE BASIC PATTERN FOR THE SYMBOLS SHOWN IN ANNEXES II AND III

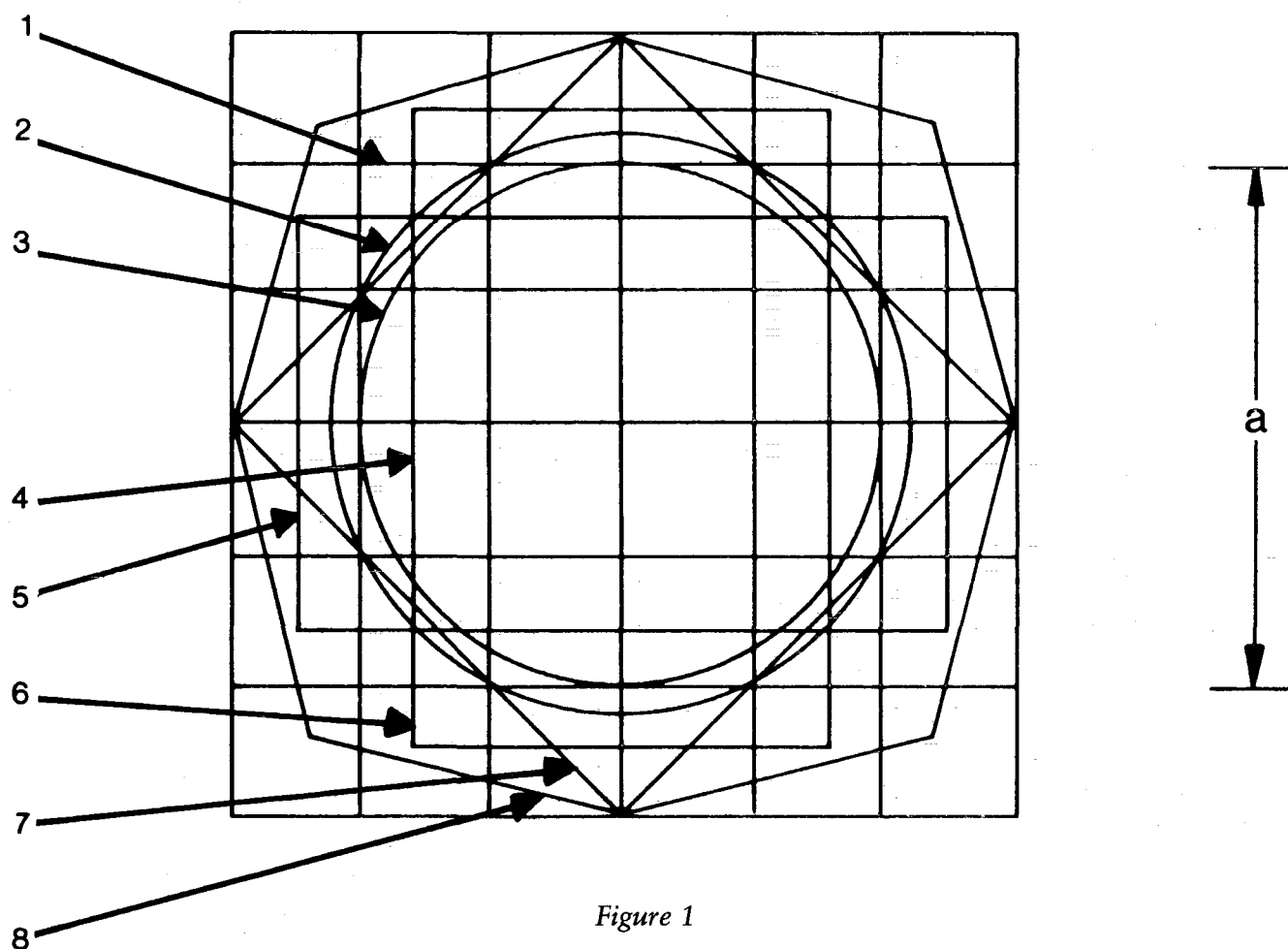

Figure 1

Basic pattern

The basic pattern comprises:

1. a basic square of side 50 mm; this dimension is equal to the nominal dimension, 'a', of the basic pattern;
2. a basic circle of 56 mm diameter having approximately the same area as the basic square (1);
3. a second circle of 50 mm diameter, being the inscribed circle of the basic square (1);
4. a second square whose corners touch the basic circle (2) and whose sides are parallel to those of the basic square (1);
- 5 and 6. two rectangles having the same area as the basic square (1); they are mutually perpendicular, each being drawn to cross opposite sides of the basic square symmetrically;
7. a third square whose sides pass through the points of intersection of the basic square (1) and the basic circle (2) and are at an angle of 45° , giving the largest horizontal and vertical dimensions of the basic pattern;
8. an irregular octagon, formed by lines at an angle of 30° to the sides of the square (7).

The basic pattern is superimposed on a 12.5 mm grid which coincides with the basic square (1).

ANNEX V

MODEL

(Maximum format: A4 (210 x 297 mm))

Name of administration

ANNEX TO THE EEC VEHICLE TYPE-APPROVAL CERTIFICATE WITH REGARD TO THE IDENTIFICATION OF CONTROLS, TELL-TALES AND INDICATORS

(Articles 4 (2) and 10 of Council Directive 70/156/EEC of 6 February 1970 on the approximation of the laws of the Member States relating to the type-approval of motor vehicles and their trailers)

- EEC type-approval No
1. Trade name or mark of the vehicle
2. Vehicle type
3. Manufacturer's name and address
4. Where applicable, name and address of manufacturer's authorized representative
5. Brief description of the vehicle type as regards the identification of controls, tell-tales and indicators
6. Vehicle submitted for type-approval on
7. Technical service conducting type-approval tests
8. Date of report issued by that service
9. Number of report issued by that service
10. Type-approval in respect of identification of controls, tell-tales and indicators is granted/refused (*)
11. Place
12. Date
13. Signature
14. The following documents, bearing the type-approval number shown above, are annexed to this certificate:
..... drawings of the controls, tell-tales and indicators and of the parts of the vehicle considered to be of importance for the purposes of Council Directive 78/316/EEC of 21 December 1977 on the approximation of the laws of the Member States relating to the interior fittings of motor vehicles (identification of controls, tell-tales and indicators).
15. Remarks

(*) Delete where inapplicable.