

Council Directive of 21 December 1977 on the approximation of the laws of the Member States relating to the defrosting and demisting systems of glazed surfaces of motor vehicles (78/317/EEC) (repealed)

COUNCIL DIRECTIVE

of 21 December 1977

on the approximation of the laws of the Member States relating to the defrosting and demisting systems of glazed surfaces of motor vehicles

(78/317/EEC) (repealed)

THE COUNCIL OF THE EUROPEAN COMMUNITIES,

Having regard to the Treaty establishing the European Economic Community, and in particular Article 100 thereof,

Having regard to the proposal from the Commission,

Having regard to the opinion of the European Parliament⁽¹⁾,

Having regard to the opinion of the Economic and Social Committee⁽²⁾,

Whereas the technical requirements which motor vehicles must satisfy pursuant to national laws relate *inter alia* to the defrosting and demisting systems of glazed surfaces of motor vehicles;

Whereas these requirements differ from one Member State to another; whereas it is therefore necessary that all Member States adopt the same requirements either in addition to or in place of their existing rules in order, in particular, to allow the EEC type-approval procedure, which was the subject of Council Directive 70/156/EEC of 6 February 1970 on the approximation of the laws of the Member States relating to the type-approval of motor vehicles and their trailers⁽³⁾, as amended by Directive 78/315/EEC⁽⁴⁾, to be introduced in respect of each type of vehicle;

Whereas it is advisable to draft the technical requirements so that they have the same aim as the work being carried out on the subject in the UN Economic Commission for Europe;

Whereas these requirements apply to motor vehicles in category M₁ (the international classification of motor vehicles is given in Annex I to Directive 70/156/EEC);

Whereas the approximation of national laws relating to motor vehicles entails reciprocal recognition by Member States of the checks carried out by each of them on the basis of the common requirements,

HAS ADOPTED THIS DIRECTIVE:

Article 1

For the purposes of this Directive, 'vehicle' means any motor vehicle in category M₁ (as defined in Annex I to Directive 70/156/EEC) intended for use on the road, having at least four wheels and a maximum design speed exceeding 25 km/h.

Article 2

No Member State may refuse to grant EEC type-approval or national type-approval of a vehicle on grounds relating to the defrosting and demisting systems of its glazed surfaces if they satisfy the requirements set out in Annexes I, II, III, IV and V.

Article 3

No Member State may refuse or prohibit the sale, registration, entry into service or use of any vehicle on grounds relating to the defrosting and demisting systems of its glazed surfaces if they satisfy the requirements laid down in Annexes I, II, III, IV and V.

Article 4

The Member State which has granted type-approval shall take the measures required to ensure that it is informed of any modification of a part or characteristic referred to in 2.2 of Annex I. The competent authorities of that State shall determine whether it is necessary to carry out further tests on the modified vehicle type and to prepare a new report. If these tests show that the requirements of this Directive have not been complied with, the modification shall not be authorized.

Article 5

Any amendments necessary to adapt the requirements of Annexes I, II, III, IV, V and VI to technical progress shall be adopted in accordance with the procedure laid down in Article 13 of Directive 70/156/EEC.

However, this procedure shall not apply to amendments introducing requirements for defrosting and demisting systems of glazed surfaces other than those of windscreens.

Article 6

1 Member States shall bring into force the provisions necessary in order to comply with this Directive within 18 months of its notification and shall forthwith inform the Commission thereof.

2 Member States shall ensure that the texts of the main provisions of national law which they adopt in the field covered by this Directive are communicated to the Commission.

Article 7

This Directive is addressed to the Member States.

Done at Brussels, 21 December 1977.

For the Council

The President

J. CHABERT

LIST OF ANNEXES

Annex I:	Scope, definitions, application for EEC type-approval, EEC type-approval, specific requirements, test procedure ^a
Annex II:	Procedure for determining the H point and the actual seat-back angle and for verifying the relative positions of the R and H points and the relationship between the design seat-back angle and the actual seat-back angle ^a
Annex III:	Method for determining the dimensional relationship between the vehicle's primary reference marks and the three-dimensional reference grid ^a
Annex IV:	Procedure for determining vision areas on windcreens of vehicles in category M ₁ vehicles in relation to the V points ^a
Annex V:	Steam generator ^a
Annex VI:	Annex to the EEC vehicle type-approval certificate with regard to the windscreen defrosting and demisting systems

^a The technical requirements of this Annex are similar to those of the relevant UN Economic Commission for Europe draft regulation; the subdivisions have thus been observed. Where a section of the draft regulation has no counterpart in the Annexes to this Directive, the number is given in brackets for the record.

ANNEX I

SCOPE, DEFINITIONS, APPLICATION FOR EEC TYPE-APPROVAL, EEC
TYPE-APPROVAL, SPECIFIC REQUIREMENTS, TEST PROCEDURE

1. SCOPE

1.1. This Directive applies to the 180° forward field of vision of the drivers of vehicles in category M₁.

1.1.1. Its purpose is to ensure good visibility under certain conditions by specifying the requirements for defrosting and demisting systems for the windscreens of category M₁ vehicles.

1.2. The requirements of this Directive are so worded as to apply to category M₁ vehicles in which the driver is on the left. In category M₁ vehicles in which the driver is on the right, these requirements shall be applied by inverting the criteria where appropriate.

2. DEFINITIONS

(2.1.)

2.2. **Vehicle type with regard to the windscreen defrosting and demisting systems**

‘Vehicle type with regard to the windscreen defrosting and demisting systems’ means vehicles which do not differ in such essential respects as:

2.2.1. the external and internal forms and arrangements within the area specified in Section 1 which may affect visibility;

2.2.2. the shape, size and characteristics of the windscreen and its mounting;

2.2.3. the characteristics of the defrosting and demisting systems;

2.2.4. the number of seats.

2.3. **Three-dimensional reference grid**

‘Three-dimensional reference grid’ means a reference system which consists of a vertical longitudinal plane X-Z, a horizontal plane X-Y and a vertical transverse plane Y-Z (see figure 2 of Annex III). The grid is used to determine the dimensional relationships between the position of design points on drawings and their position on the actual vehicle. The procedure for situating the vehicle relative to the grid is specified in Annex III; all coordinates referred to ground zero shall be based on a vehicle in running order (as defined in 2.6 of Annex I to Directive 70/156/EEC plus one front-seat passenger, the mass of the passenger being 75 kg ± 1%).

2.3.1. Vehicles fitted with suspension enabling their ground clearance to be adjusted shall be tested under the normal conditions of use specified by the vehicle manufacturer.

2.4. Primary reference marks

‘Primary reference marks’ means holes, surfaces, marks and identification signs on the vehicle body. The type of reference mark used and the position of each mark relative to the X, Y and Z coordinates of the three-dimensional reference grid and to a design ground plane shall be specified by the vehicle manufacturer. These marks may be the control points used for body-assembly purposes.

2.5. Seat-back angle

(See Annex II).

2.6. Actual seat-back angle

(See Annex II).

2.7. Design seat-back angle

(See Annex II).

2.8. V points

‘V points’ means points whose position in the passenger compartment is determined by vertical longitudinal planes passing through the centres of the outermost designated seating positions on the front seat and in relation to the R point and the design angle of the seat back, which points are used for verifying compliance with the field-of-view requirements (see Annex IV).

2.9. R point or seating reference point

(See Annex II).

2.10. H point

(See Annex II).

2.11. Windscreen datum points

‘Windscreen datum points’ means points situated at the intersection with the windscreen of lines radiating forward from the V points to the outer surface of the windscreen.

2.12. Transparent area of a windscreen

‘Transparent area of a windscreen’ means that area of a vehicle windscreen or other glazed surface whose light transmittance, measured at right angles to the surface, is not less than 70%.

2.13. Horizontal seat-adjustment range

‘Horizontal seat-adjustment range’ means the range of normal driving positions designated by the vehicle manufacturer for the adjustment of the driver's seat in the direction of the X axis (see 2.3).

2.14. Extended seat-adjustment range

‘Extended seat-adjustment range’ means the range designated by the vehicle manufacturer for the adjustment of the seat in the direction of the X axis (see 2.3) beyond the range of normal driving positions specified in 2.13 and used for converting seats into beds or facilitating entry into the vehicle.

2.15. Defrosting system

‘Defrosting system’ means the system intended to melt frost or ice on the surface of the windscreen and thus restore visibility.

2.16. Defrosting

‘Defrosting’ means the elimination of frost or ice covering the glazed surfaces by the operation of defrosting or windscreen-wiper systems.

2.17. **Defrosted area**

‘Defrosted area’ means the area of the glazed surfaces having a dry surface or covered with melted or partially melted (wet) frost which can be removed from the outside face by the windscreen wipers. It excludes the area of the windscreen covered with dry frost.

2.18. **Demisting system**

‘Demisting system’ means the system intended to remove a film of condensate on the inside surface of the windscreen and thus restore visibility.

2.19. **Mist**

‘Mist’ means a film of condensate on the inside face of the glazed surfaces.

2.20. **Demisting**

‘Demisting’ means the elimination of the mist covering the glazed surfaces by the operation of the demisting system.

3. APPLICATION FOR EEC TYPE-APPROVAL

3.1. The application for EEC type-approval of a vehicle type with regard to its windscreen defrosting and demisting systems shall be submitted by the vehicle manufacturer or by his authorized representative.

3.2. It shall be accompanied by the following documents in triplicate, and by the following particulars:

3.2.1. a description of the vehicle referring to the criteria mentioned in 2.2, together with dimensional drawings and either a photograph or an exploded view of the passenger compartment. The numbers and/or symbols identifying the vehicle type shall be specified;

3.2.2. particulars of the primary reference marks in sufficient detail to enable them to be readily identified and the position of each in relation to the others and to the R point to be verified;

3.2.3. a technical description of the defrosting and demisting systems, together with relevant data in sufficient detail.

3.3. A vehicle representative of the vehicle type to be approved shall be submitted to the technical service conducting the type-approval tests.

4. EEC TYPE-APPROVAL

(4.1.)

(4.2.)

4.3. A certificate conforming to the model in Annex VI shall be attached to the EEC type-approval certificate.

(4.4.)

(4.5.)

(4.6.)

(4.7.)

5. SPECIFIC REQUIREMENTS

5.1. **Windscreen defrosting**

5.1.1. Every vehicle shall be equipped with a system for removing frost and ice from the glazed surfaces of the windscreen. The windscreen defrosting system shall be effective enough to ensure adequate visibility through the windscreen in cold weather.

5.1.2. The efficiency of the system shall be verified by determining the defrosted area of the windscreen periodically after starting the engine, the vehicle having been kept in a cold chamber for a certain amount of time.

5.1.3. The requirements of 5.1.1 and 5.1.2 shall be checked using the method set out in 6.1.

5.1.4. The following requirements must be satisfied:

5.1.4.1. 20 minutes after the start of the test period, the area defined in 2.2 of Annex IV (area A) must be 80% defrosted;

5.1.4.2. 25 minutes after the start of the test period, the defrosted area of the windscreen on the passenger side shall be comparable to that specified in 5.1.4.1 for the driver's side;

5.1.4.3. 40 minutes after the start of the test period, the area defined in 2.3 of Annex IV (area B) shall be 95% defrosted.

(5.1.5.)

5.2. **Windscreen demisting**

5.2.1. Every vehicle shall be equipped with a system for removing mist from the interior glazed surface of the windscreen.

5.2.2. The demisting system shall be effective enough to restore visibility through the windscreen in wet weather. Its efficiency shall be verified by the procedure described in 6.2.

5.2.3. The following requirements must be satisfied:

5.2.3.1. the area defined in 2.2 of Annex IV (area A) must be 90% demisted in 10 minutes;

(5.2.3.2.)

5.2.3.3. the area defined in 2.3 of Annex IV (area B) shall be 80% demisted in 10 minutes.

(5.2.4.)

6. TEST PROCEDURE

6.1. **Windscreen defrosting**

6.1.1. The tests shall be carried out at one of the temperatures specified below as prescribed by the manufacturers: -8 ± 2 °C or -18 ± 3 °C.

6.1.2. The test shall be carried out in a cold chamber large enough to contain the complete vehicle and equipped to maintain one of the temperatures mentioned in 6.1.1 in the chamber throughout the test and to circulate cold air. The cold chamber shall be maintained at or below the specified test temperature for not less than 24 hours before the start of the period during which the vehicle is exposed to cold.

- 6.1.3. Before the test, the inner and outer surfaces of the windscreen shall be thoroughly degreased by means of methylated spirit or an equivalent degreasing agent. After drying, a solution of ammonia of not less than 3% and not more than 10% shall be applied. The surface shall be allowed to dry again and then be wiped with a dry cotton cloth.
- 6.1.4. The vehicle, with the engine stopped, shall be kept for not less than 10 hours at the test temperature.
 - 6.1.4.1. If instruments are available to check that the engine coolant and lubricant are stabilized at the test temperature, this period may be shortened.
- 6.1.5. Following the exposure period prescribed in 6.1.4, an even layer of ice of 0.044 g/cm^2 shall be applied over the entire outside surface of the windscreen by means of a waterspray gun working at 3.5 ± 0.2 bar operating pressure.
 - 6.1.5.1. The spray nozzle, adjusted to full fan pattern and maximum flow, shall be held perpendicular to and at a distance of between 200 and 250 mm from the glazed surface, and so directed as to form an even layer of ice right across the windscreen from one side to the other.
 - 6.1.5.1.1. A spray gun having a nozzle of 1.7 mm diameter and a liquid flowrate of 0.395 l/min, and capable of producing a fan pattern of 300 mm diameter on the glazed surface at a distance 200 mm from that surface, may be used to satisfy the requirements of 6.1.5. Any other device by which the requirements can be satisfied shall also be permitted.
- 6.1.6. After the ice has been formed on the windscreen, the vehicle shall be kept in the cold chamber for not less than 30 minutes and not more than 40 minutes.
- 6.1.7. After the period prescribed in 6.1.6 has elapsed, one or two observers shall enter the vehicle, and the engine may be started, if necessary by some external means. The test period shall commence as soon as the engine is running.
 - 6.1.7.1. During the first five minutes of the test period, the engine speed or speeds may be those which the manufacturer recommends for warming up when starting in cold weather.
 - 6.1.7.2. During the final 35 minutes of the test period (or during the entire test period if the five-minute warming-up procedure is not followed) the engine must run:
 - 6.1.7.2.1. at a speed not exceeding 50% of the speed corresponding to its maximum power output; moreover,
 - (6.1.7.2.2.)
 - 6.1.7.2.3. the battery must be fully charged;
 - 6.1.7.2.4. the voltage at the terminals of the defrosting device may be not more than 20% above the nominal rating of the system;
 - 6.1.7.2.5. the temperature in the test chamber shall be measured at the level of the centre of the windscreen, at a point not significantly affected by heat from the vehicle under test;
 - 6.1.7.2.6. the horizontal component of the speed of the air cooling the chamber, measured immediately prior to the test, in the median plane of the vehicle at a point 300 mm forward of the base of the windscreen and at a level half-way between the base and the top of the windscreen, must be as low as possible and in any event less than 8 km/h;

- 6.1.7.2.7. the engine bonnet, the doors and the vents, except the intakes and outlets of the heating and ventilating system, must be closed; one or two windows may be opened for a total vertical distance of 25 mm if the vehicle manufacturer so requests;
- 6.1.7.2.8. the defrosting system temperature control shall be set to the 'maximum' position;
- 6.1.7.2.9. the windscreen wipers may be used during the test if they can operate without manual assistance;
- 6.1.7.2.10. the defrosting system prescribed by the manufacturer shall be brought into operation, with the vehicle in the condition specified by the manufacturer for satisfactory operation at low temperature.
- 6.1.8. The observer(s) shall outline the defrosted area on the inside surface of the windscreen, at five-minute intervals from the start of the test period.
- 6.1.9. On completion of the test, the pattern of the defrosted area outlined on the inner face of the windscreen as required by 6.1.8 shall be noted and marked to identify the driver's side.
- 6.2. **Windscreen demisting**
- 6.2.1. Before the test, the inside surface of the windscreen shall be thoroughly degreased by means of methylated spirit, or an equivalent degreasing agent. After drying, a solution of ammonia of not less than 3% and not more than 10% shall be applied. The surface shall be allowed to dry again and then be wiped with a dry cotton cloth.
- 6.2.2. The test shall be carried out in an environmental chamber large enough to take the complete vehicle and capable of producing and maintaining a test temperature of -3 ± 1 °C throughout the test period.
- 6.2.2.1. The temperature in the test chamber shall be measured at the level of the centre of the windscreen, at a point not significantly affected by heat from the vehicle under test.
- 6.2.2.2. The horizontal component of the speed of the air cooling the chamber, measured immediately prior to the test, in the median plane of the vehicle at a point 300 mm forward of the base of the windscreen and at a level half-way between the base and the top of the windscreen, must be as low as possible and in any event less than 8 km/h;
- 6.2.2.3. The engine bonnet, the docks and the vents, except the intakes and outlets of the heating and ventilation system, must be closed; one or two windows may be opened from the beginning of the demisting test for a total vertical distance of 25 mm if the vehicle manufacturer so requests.
- 6.2.3. The mist shall be produced by means of the steam generator described in Annex V. The generator must contain enough water to generate at least 70 ± 5 g/h of steam for each seating position designated by the manufacturer, in an ambient temperature of -3 ± 1 °C.
- 6.2.4. The inside surface of the windscreen shall be cleaned as prescribed in 6.2.1 and the vehicle placed in the environmental chamber. The ambient air temperature shall be lowered until the temperature of the engine coolant, the lubricants and the air inside the vehicle are stabilized at -3 ± 1 °C.
- 6.2.5. The steam generator shall be placed with its outlets in the median plane of the vehicle at a height of 580 ± 80 mm above the R point of the driver's seat. It shall normally be placed immediately behind the front seat backrest, with the seat-back, if adjustable, set

at the prescribed angle. Where the design of the vehicle precludes this, the generator may be placed in front of the backrest, in the nearest convenient position to that mentioned above.

6.2.6. After the generator has been operating for five minutes inside the vehicle, one or two observers shall enter the front of the vehicle, the output of the generator being then reduced by 70 ± 5 g/h for each observer.

6.2.7. One minute after the observer or observers have entered the vehicle, the engine shall be started as indicated by the manufacturer. The test period shall commence as soon as the engine is running.

6.2.7.1. Throughout the test the engine must run:

6.2.7.1.1. at a speed not exceeding 50% of the speed corresponding to its maximum power output; moreover,

(6.2.7.1.2.)

6.2.7.1.3. the vehicle demister controls must be set as recommended by the vehicle manufacturer for the test temperature;

6.2.7.1.4. the battery must be fully charged;

6.2.7.1.5. the voltage at the terminals of the demisting device may be not more than 20% above the nominal rating of the system.

6.2.8. At the end of the test, the demist pattern shall be recorded.

(7.)

(8.)

(9.)

(10.)

(11.)

(12.)

ANNEX II

PROCEDURE FOR DETERMINING THE H POINT AND THE ACTUAL SEAT-BACK ANGLE AND FOR VERIFYING THE RELATIVE POSITIONS OF THE R AND H POINTS AND THE RELATIONSHIP BETWEEN THE DESIGN SEAT-BACK ANGLE AND THE ACTUAL SEAT-BACK ANGLE

Annex III to Council Directive 77/649/EEC of 27 September 1977 on the approximation of the laws of the Member States relating to the field of vision of motor vehicle drivers⁽⁵⁾ shall be applicable.

ANNEX III

METHOD FOR DETERMINING THE DIMENSIONAL RELATIONSHIPS BETWEEN THE VEHICLE'S PRIMARY REFERENCE MARKS AND THE THREE-DIMENSIONAL REFERENCE GRID

1. RELATIONSHIP BETWEEN REFERENCE GRID AND VEHICLE'S PRIMARY REFERENCE MARKS

To verify specific dimensions on or within a vehicle submitted for type-approval in accordance with this Directive, the relationship between the coordinates of the three-dimensional reference grid defined in 2.3 of Annex I, which have been laid out at the initial vehicle-design stage, and the positions of the primary reference marks defined in 2.4 of Annex I, must be established accurately so that specific points on the vehicle manufacturer's drawings can be located on an actual vehicle produced from those drawings.

2. METHOD FOR ESTABLISHING RELATIONSHIP OF REFERENCE GRID TO REFERENCE MARKS

For this purpose, a ground reference plane shall be constructed, which is marked with the X-X measurement and the Y-Y measurement. The method of achieving this is set out in figure 3 of this Annex, the reference plane being a hard, flat, level surface on which the vehicle stands, and which has two measuring scales firmly fixed to its surface; these shall be graduated in millimetres, the X-X scale being not less than 8 m long, and the Y-Y scale not less than 4 m long. The two scales must be set at right angles to each other as shown in figure 3 of this Annex. The intersection of the scales is ground zero.

3. EXAMINATION OF THE REFERENCE PLANE

In order to provide for minor variations in the level of the reference plane or test area, it is necessary to measure the deviations from ground zero along both the X and Y scales at intervals of 250 mm and to record the readings obtained so that corrections can be made when checking the vehicle.

4. ACTUAL TEST ATTITUDE

In order to provide for minor changes in suspension height, etc., it is necessary to have available a means of bringing the primary reference marks to the correct coordinate positions relative to the design attitude before further measurements are taken. In addition, it must be possible to make minor lateral and/or longitudinal adjustments to the vehicle's position so as to place it correctly in relation to the reference grid.

5. RESULTS

The vehicle having been correctly placed relative to the reference grid and in its design attitude, the site of the necessary points for studying the forward visibility requirements can be readily determined. Test methods to determine these requirements may include the use of theodolites, light sources or shadow devices, or any other method which can be shown to give equivalent results.

Figure 1

Determination of 'V' points for a seat-back angle of 25°

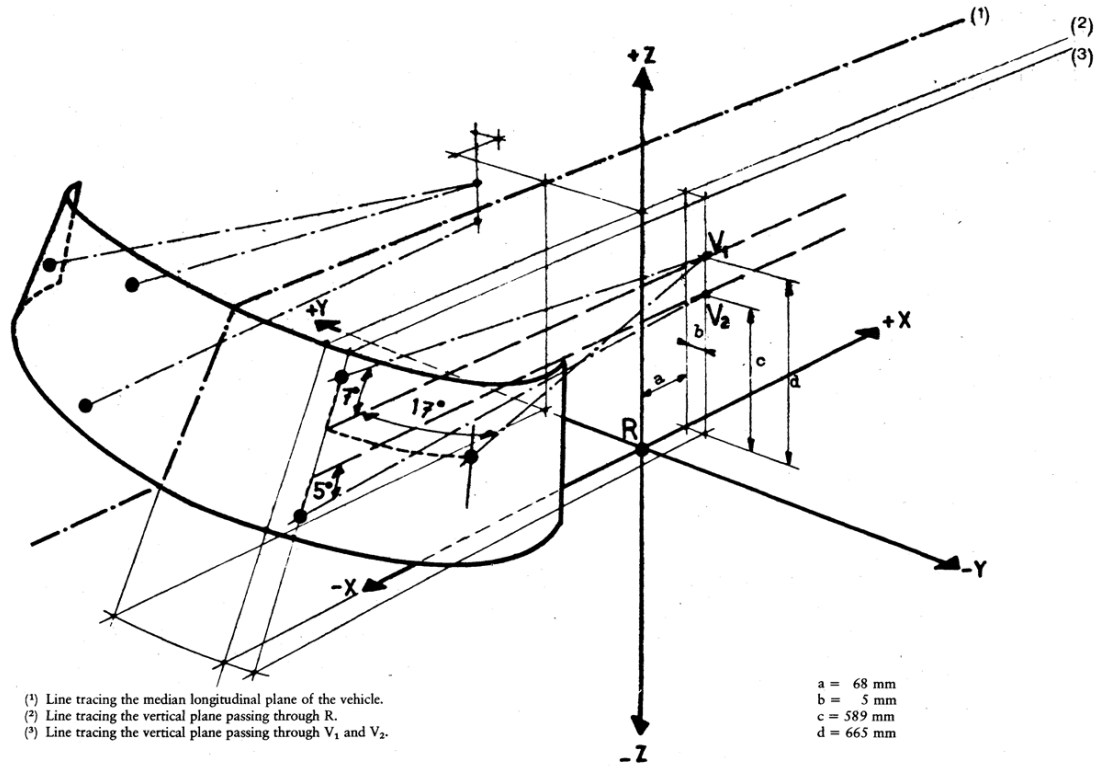

Figure 2

Three-dimensional reference grid

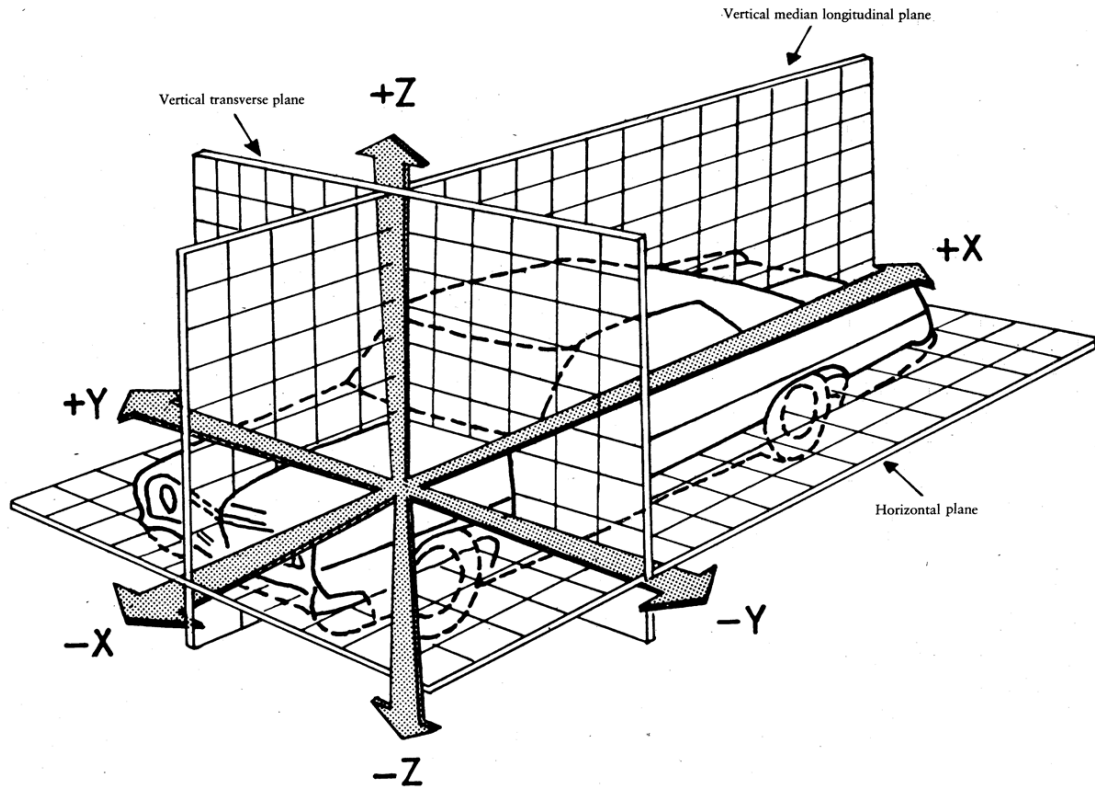
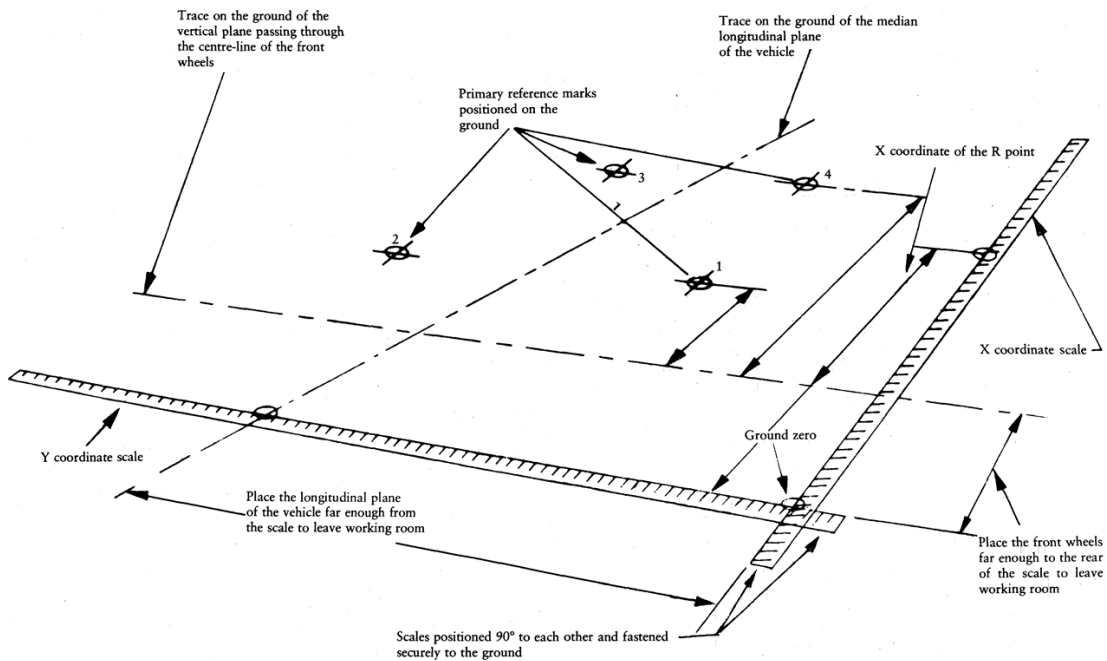

Figure 3

Level work space



ANNEX IV

PROCEDURE FOR DETERMINING VISION AREAS ON WINDSCREENS OF CATEGORY VEHICLES IN RELATION TO THE V POINTS

1. POSITIONS OF THE V POINTS
 - 1.1. The positions of the V points in relation to the R point, as indicated by XYZ coordinates from the three-dimensional reference grid, are as shown in Tables I and II.
 - 1.2. Table I indicates the basic coordinates for a design seat-back angle of 25°. The positive direction for the coordinates is indicated in figure 1 of Annex III.

TABLE I

V point	X	Y	Z
v ₁	68 mm	— 5 mm	665 mm
v ₂	68 mm	— 5 mm	589 mm

- 1.3. **Correction for design seat-back angles other than 25°**
 - 1.3.1. Table II shows the further corrections to be made to the X and Z coordinates of each V point when the design seat-back angle is not 25°. The positive direction for the coordinates is shown in figure 1 of Annex III.

TABLE II

Seat-back angle (in°)	Horizontal coordinates ΔX	Vertical coordinates ΔZ	Seat-back angle (in°)	Horizontal coordinates ΔX	Vertical coordinates ΔZ
5	— 186 mm	28 mm	23	— 18 mm	5 mm
6	— 177 mm	27 mm	24	— 9 mm	3 mm
7	— 167 mm	27 mm	25	0 mm	0 mm
8	— 157 mm	27 mm	26	9 mm	— 3 mm
9	— 147 mm	26 mm	27	17 mm	— 5 mm
10	— 137 mm	25 mm	28	26 mm	— 8 mm
11	— 128 mm	24 mm	29	34 mm	— 11 mm
12	— 118 mm	23 mm	30	43 mm	— 14 mm
13	— 109 mm	22 mm	31	51 mm	— 18 mm
14	— 99 mm	21 mm	32	59 mm	— 21 mm
15	— 90 mm	20 mm	33	67 mm	— 24 mm
16	— 81 mm	18 mm	34	76 mm	— 28 mm
17	— 72 mm	17 mm	35	84 mm	— 32 mm

Status: This is the original version (as it was originally adopted).

18	— 62 mm	15 mm	36	92 mm	— 35 mm
19	— 53 mm	13 mm	37	100 mm	— 39 mm
20	— 44 mm	11 mm	38	108 mm	— 43 mm
21	— 35 mm	9 mm	39	115 mm	— 48 mm
22	— 26 mm	7 mm	40	123 mm	— 52 mm

2. VISION AREAS

- 2.1. Two vision areas shall be determined from the V points.
- 2.2. Vision area A is the area on the outer surface of the windscreen bounded by the following four planes extending forward from the V point (see figure 1):
- a vertical plane passing through V_1 and V_2 and at an angle of 13° to the left of the X axis,
 - a plane parallel to the Y axis, passing through V_1 and at an upward angle of 3° from the X axis,
 - a plane parallel to the Y axis, passing through V_2 and at a downward angle of 1° from the X axis,
 - a vertical plane passing through V_1 and V_2 and at an angle of 20° to the right of the X axis.
- 2.3. Vision area B is the area of the outer surface of the windscreen which is more than 25 mm from the outer edge of the transparent area and is bounded by the intersection of the following four planes with the outer surface of the windscreen (see figure 2):
- a plane parallel to the Y axis, passing through V_1 and at an upward angle of 7° from the X axis,
 - a plane parallel to the Y axis, passing through V_2 and at a downward angle of 5° from the X axis,
 - a vertical plane passing through V_1 and V_2 and at an angle of 17° to the left of the X axis,
 - a plane symmetrical to the former plane in relation to the median longitudinal plane of the vehicle.

Figure 1

Vision area A

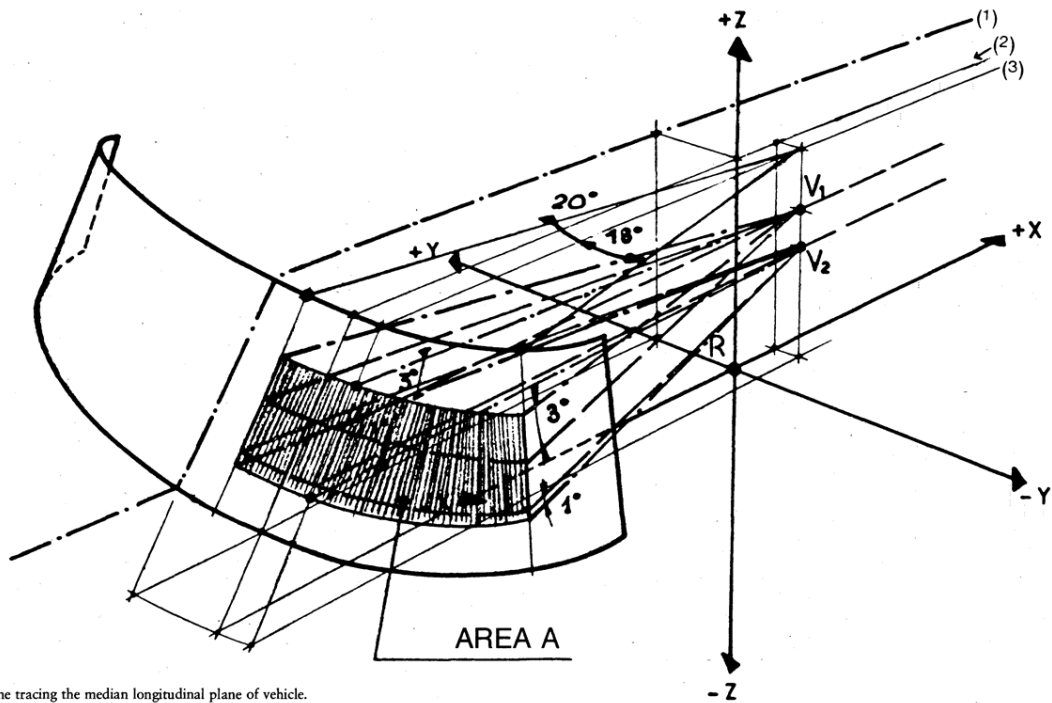

- (1) Line tracing the median longitudinal plane of vehicle.
- (2) Line tracing the vertical plane passing through R.
- (3) Line tracing the vertical plane passing through V₁ and V₂.

Figure 2

Vision area B

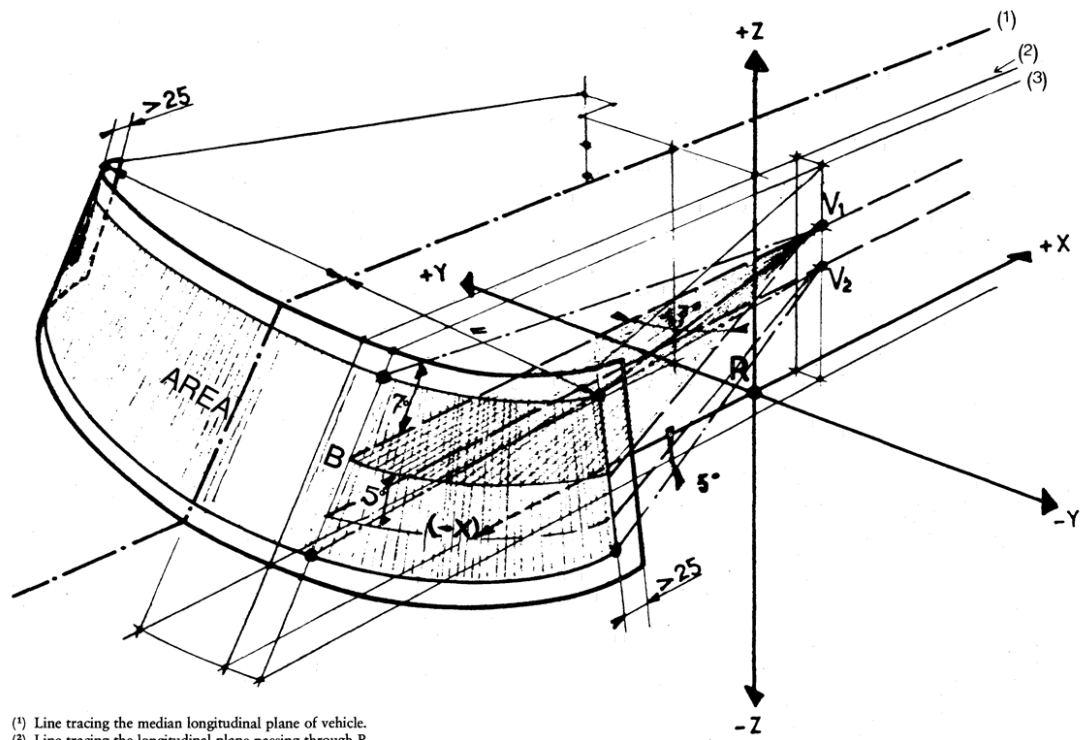

- (1) Line tracing the median longitudinal plane of vehicle.
- (2) Line tracing the longitudinal plane passing through R.
- (3) Line tracing the longitudinal plane passing through V₁ and V₂.

ANNEX V

STEAM GENERATOR

The steam generator used for the test must have the following characteristics:

- (a) the water container must have a capacity of at least 2.25 litres;
- (b) the heat loss at boiling point must not exceed 75 W in an ambient temperature of 3 ± 1 °C;
- (c) the fan must have a capacity of 0.07 to 0.10 m³/min at 0.5 mbar static pressure;
- (d) six steam outlet holes of 6.3 mm diameter must be provided round the top of the generator;
- (e) the generator must be calibrated at 3 ± 1 °C to give readings for each 70 ± 5 g/h output up to a maximum of n times this figure, where n is the number of seating positions designated by the manufacturer.

Diagram of steam generator

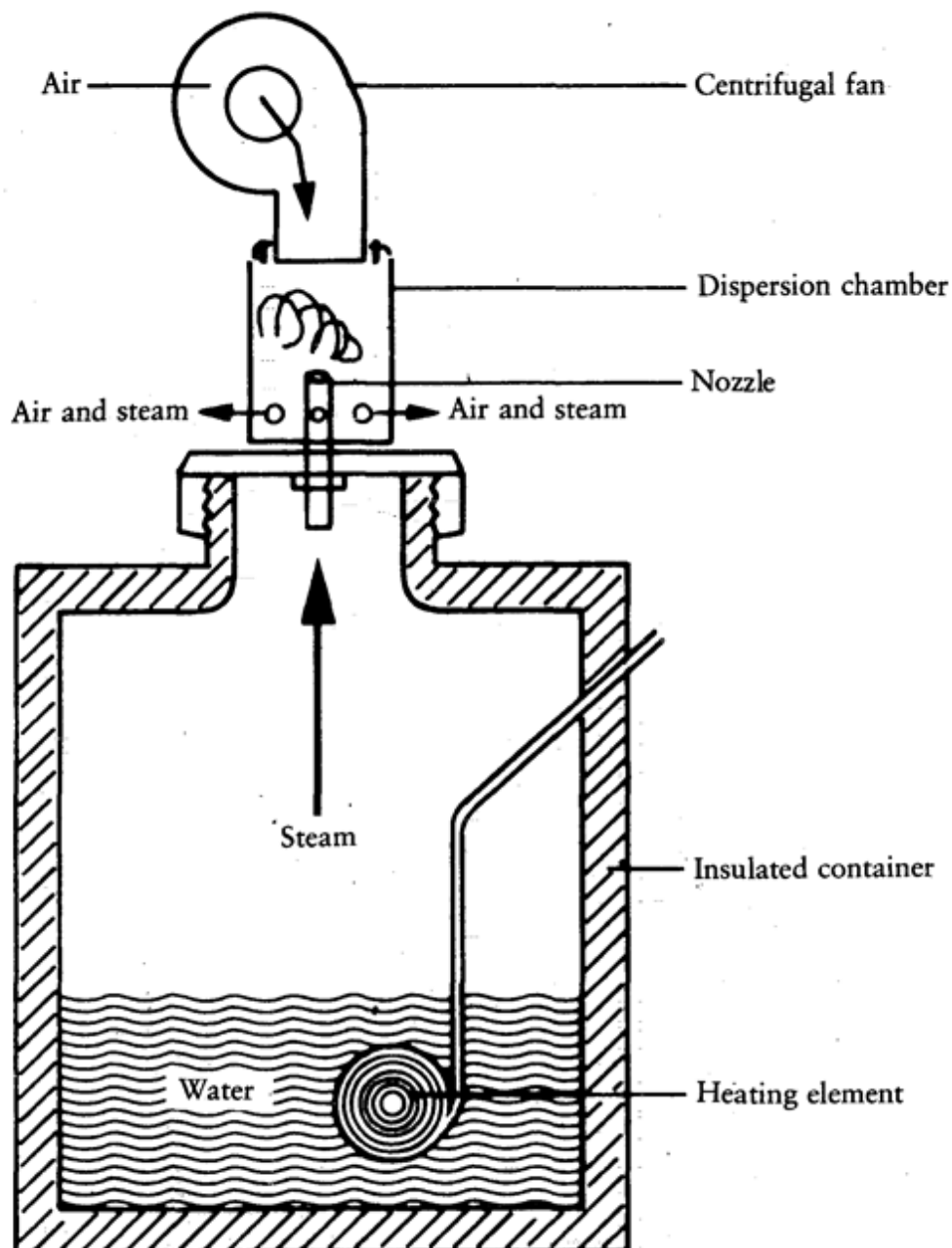

Dimensions and characteristics of steam generator

Component	Dimensions	Material
Nozzle	(a) Length 10 cm (b) Inside diameter 1.5 cm	Brass
Dispersion chamber	(a) Length 11.5 cm (b) Diameter 7.5 cm (c) Six holes of 0.63 cm evenly spaced	Brass pipe of 0.38 mm wall thickness

Status: This is the original version (as it was originally adopted).

	2.5 cm above bottom of the chamber	
--	--	--

ANNEX VI

MODEL

(Maximum format: A4 (210 × 297 mm))

Name of
administration

ANNEX TO THE EEC VEHICLE TYPE-APPROVAL CERTIFICATE WITH REGARD TO THE
WINDSCREEN DEFROSTING AND DEMISTING SYSTEMS

(Articles 4 (2) and 10 of Council Directive 70/156/EEC of 6 February 1970 on the approximation
of the laws of the Member States relating to the type-approval of motor vehicles and their trailers)

- EEC type-approval No
1. Trade name or mark of the vehicle
 2. Vehicle type
 3. Manufacturer's name and address
 4. Where applicable, name and address of manufacturer's authorized representative
 5. Brief description of the vehicle
 6. Number of seats
 7. Brief description of defrosting and demisting systems
 8. Defrost test temperature: — 8 ± 2 °C/— 18 ± 3 °C (*)
 9. Rated voltage of electrical installation
 10. Characteristics of windscreen:
laminated/toughened (*)
thickness of component parts: mm
 11. Particulars of windscreen mounting
 12. Identification data for R point of driver's designated seating position in relation to position of
primary reference marks

(*) Delete where inapplicable.

Status: This is the original version (as it was originally adopted).

- 13. Identification, location and relative positions of primary reference marks
.....
.....
.....
- 14. Vehicle submitted for type-approval on
- 15. Technical service conducting type-approval tests
.....
- 16. Date of report issued by that service
- 17. Number of report issued by that service
- 18. Type-approval in respect of windscreen defrosting and demisting systems is granted/refused (*)
- 19. Place
- 20. Date
- 21. Signature
- 22. The following documents, bearing the type-approval number shown above, are annexed to this certificate:
..... dimensional drawings
..... exploded view or photograph of the passenger compartment
..... characteristics of the defrosting system
..... characteristics of the demisting system
- 23. Remarks

Status: This is the original version (as it was originally adopted).

- (1) OJ No C 118, 16. 5. 1977, p. 33.
- (2) OJ No C 114, 11. 5. 1977, p. 9.
- (3) OJ No L 42, 23. 2. 1970, p. 1.
- (4) See page 1 of this Official Journal.
- (5) OJ No L 267, 19. 10. 1977, p. 1.