

This document is meant purely as a documentation tool and the institutions do not assume any liability for its contents

► B

COMMISSION DIRECTIVE

of 18 April 1979

adapting to technical progress Council Directive 71/320/EEC on the approximation of the laws of the Member States relating to the braking devices of certain categories of motor vehicles and their trailers

(79/489/EEC)

(OJ L 128, 26.5.1979, p. 12)

Corrected by:

► C1 Corrigendum, OJ L 188, 26.7.1979, p. 54 (79/489/EEC)



COMMISSION DIRECTIVE

of 18 April 1979

adapting to technical progress Council Directive 71/320/EEC on the approximation of the laws of the Member States relating to the braking devices of certain categories of motor vehicles and their trailers

(79/489/EEC)

THE COMMISSION OF THE EUROPEAN COMMUNITIES,

Having regard to the Treaty establishing the European Economic Community,

Having regard to Council Directive 70/156/EEC of 6 February 1970 on the approximation of the laws of the Member States relating to the type-approval of motor vehicles and their trailers⁽¹⁾, as last amended by Directive 78/547/EEC⁽²⁾, and in particular Articles 11, 12 and 13 thereof,

Having regard to Council Directive 71/320/EEC of 26 July 1971 on the approximation of the laws of the Member States relating to the braking devices of certain categories of motor vehicles and their trailers⁽³⁾, as last amended by Commission Directive 75/524/EEC⁽⁴⁾,

Whereas, in view of experience gained and of the state of the art, it is now possible to make requirements more stringent and to match them more closely to actual test conditions;

Whereas the provisions of this Directive are in accordance with the opinion of the Committee on the Adaptation to Technical Progress of the Directives Aimed at the Removal of Technical Barriers to Trade in the Motor Vehicle Sector,

HAS ADOPTED THIS DIRECTIVE:

Article 1

1. Annexes I, II, III, IV, V, VI and IX to Directive 71/320/EEC are hereby amended in accordance with the Annex to this Directive.

2. Pending the entry into force of special provisions concerning wheel anti-locking systems, vehicles of categories M₁, M₂, M₃, N₁, N₂, N₃, O₃ and O₄ which are fitted with these systems shall be subject to the provisions of Directive 71/320/EEC, as last amended by this Directive.

Article 2

1. As from 1 January 1980, no Member State may, on grounds relating to braking devices:

- refuse, in respect of a type of vehicle, to grant EEC type-approval, or to issue the copy of the certificate provided for in the last indent of Article 10 (1) of Directive 70/156/EEC, or to grant national type-approval, or
- prohibit the entry into service of vehicles,

where the braking devices of such type of vehicle or of such vehicles comply with the provisions of Directive 71/320/EEC, as last amended by this Directive.

2. As from 1 October 1980, Member States:

- shall no longer issue the copy of the certificate provided for in the last indent of Article 10 (1) of Directive 70/156/EEC in respect of a

⁽¹⁾ OJ No L 42, 23. 2. 1970, p. 1.

⁽²⁾ OJ No L 168, 26. 6. 1978, p. 39.

⁽³⁾ OJ No L 202, 6. 9. 1971, p. 37.

⁽⁴⁾ OJ No L 236, 8. 9. 1975, p. 3.

▼B

- type of vehicle of which the braking devices do not comply with the provisions of Directive 71/320/EEC, as last amended by this Directive,
- ►C1 may ◀ refuse to grant national type-approval of a type of vehicle of which the braking devices do not comply with the provisions of Directive 71/320/EEC, as last amended by this Directive.
3. As from 1 October 1981, Member States may prohibit the entry into service of vehicles of which the braking devices do not comply with the provisions of Directive 71/320/EEC, as last amended by this Directive.
4. Notwithstanding paragraphs 1 to 3, Member States shall implement the provisions of item 1.2.1 of Annex IV to Directive 71/320/EEC, as amended by this Directive, only with effect from 1 October 1983.
5. Before 1 January 1980, Member States shall bring into force the provisions necessary in order to comply with this Directive, and shall forthwith inform the Commission thereof.

Article 3

This Directive is addressed to the Member States.



ANNEX

Amendments to the Annexes to Directive 71/320/EEC as amended by Directive 74/132/EEC and by Directive 75/524/EEC

I. GENERAL PROVISIONS RELATING TO UNITS OF MEASUREMENT

The specifications of Directive 71/320/EEC and of its amending Directives shall be amended in accordance with the provisions of Directive 71/354/EEC as last amended by Directive 76/770/EEC relating to units of measurement.

For this purpose, in the Annexes to Directives 71/320/EEC, 74/132/EEC and 75/524/EEC:

- the word 'weight' shall be replaced by the word 'mass' and the words 'maximum weight' and 'total weight' shall be replaced by the words 'maximum mass',
- the values of force, torque and moment and pressure shall be expressed in the following units:

force: Newton (N),

torque and moment: Newton metre (Nm),

pressure: bar (bar).

The following rounded values shall be used to convert the units used before this Directive took effect into the abovementioned units:

force: 1 kgf or 1 kg = 10 N,

torque and moment: 1 mkgf or 1 mkg = 10 Nm,

pressure: 1 kgf/cm² or 1 kg/cm² = 1 bar.

Where appropriate, the forces corresponding to the vehicle mass or to parts of this mass (e.g. axle loads) must be used in the calculations prescribed in these Annexes.

II. SPECIAL PROVISIONS

ANNEX I: DEFINITIONS, REQUIREMENTS, CONSTRUCTION AND FITTING

Item 2.2.1.2.4 add at the end:

'this provision shall not apply where an auxiliary control permits at least partial actuation of the service braking system, as provided for in Annex II, item 2.1.3.6.'

Item 2.2.1.2.7 the first sentence shall read:

'Certain parts, such as the pedal and its bearing, the master cylinder and its piston or pistons (hydraulic systems), the control valve (pneumatic systems), the linkage between the pedal and the master cylinder or the control valve, the brake cylinders and their pistons (hydraulic and/or pneumatic systems) and the lever-and-cam assemblies of brakes, shall not be regarded as liable to breakage if they are amply dimensioned, are readily accessible for maintenance, and exhibit safety features at least equal to those prescribed for other essential components (such as the steering linkage) of the vehicle.'

Item 2.2.1.13 shall read:

'2.2.1.13. Any vehicle fitted with a service brake actuated by an energy reservoir must, where the prescribed secondary braking performance cannot be obtained by means of this brake without the use of stored energy, be provided with a warning device — in addition to a pressure gauge, where fitted — giving an optical or acoustic signal when the stored energy in any part of the system falls to a value at which, without recharging of the reservoir and irrespective of the load conditions of the vehicle, it is possible to apply the service brake control a fifth time after four full-stroke actuations and obtain the prescribed secondary braking performance (without faults in the service-brake transmission device and with the brakes adjusted as closely as possible). The warning device must be directly and permanently connected to the circuit. When the engine is running

▼B

under normal operating conditions and there are no faults in the braking system, the warning device must give no signal except during the time required for charging the energy reservoir(s) after start-up of the engine.'

Item 2.2.1.19.2 add at the end:

'if this operation is achieved by a valve which is normally at rest, then such a valve may only be incorporated if its correct functioning can easily be checked by the driver, either from within the cab or from outside the vehicle, without the use of tools.'

ANNEX II: BRAKING TESTS AND PERFORMANCE OF BRAKING DEVICES

Item 1.3.2.1 the first line shall read:

'The service brakes of trailers of categories O₂, O₃ and O₄ shall be tested in such a manner that ...'

After item 2.1.3.5 a new item 2.1.3.6 shall be added:

'2.1.3.6. To check compliance with the requirements of Annex I, item 2.2.1.2.4, a type O test must be carried out, with the engine disengaged, at the test speed specified in item 2.1.1 for the relevant vehicle category. The mean fully developed deceleration on application of either the parking brake or the auxiliary control of the service brake, and the deceleration immediately before the vehicle stops, shall be not less than 1.5 m/s². The test shall be carried out with the vehicle laden, and compliance with the requirements shall be deemed to be met if the braking performance has been achieved once. The force exerted on the braking control shall not exceed the specified values. In the case of vehicles of category M₁ or N₁, fitted with a parking brake using friction linings other than those for the service braking system, the test may be carried out from 60 km/h at the request of the manufacturer. In this case, the mean fully-developed deceleration must be not less than 2.0 m/s²; deceleration immediately before the vehicle stops must not be less than 1.5 m/s².'

Item 2.2.1.3 shall read:

'2.2.1.3. Requirements relating to the testing of category O₃ vehicles. The same requirements apply as to category O₂.'

Item 2.2.1.4.1 shall read:

'2.2.1.4.1. The same requirements apply as apply to category O₂; in addition, these vehicles must be subjected to the Type II test.'

Item 2.3.2 shall read:

'2.3.2. In the case of vehicles fitted with compressed air braking devices, the requirements of item 2.3.1 are considered to be satisfied if the vehicle complies with the provisions of Annex III.'

ANNEX III

The title shall read:

'METHOD OF MEASURING THE REACTION TIME FOR VEHICLES FITTED WITH COMPRESSED AIR BRAKING DEVICES'

Item 1.3 shall read:

'1.3. The times determined in implementing the provisions of this Annex shall be rounded to the nearest 10th of a second. If the figure representing the 100ths is five or more, the reaction time shall be rounded up to the next higher 10th.'

The former item 1.4 shall be deleted.

Item 2.4 the last sentence shall be deleted.

▼B

Item 2.5 shall read:

- ‘2.5. In the case of motor vehicles having a brake coupling for trailers, in addition to the requirements of item 1.1 the reaction time must be measured at the extremity of a pipe 2.5 m long with an internal diameter of 13 mm which shall be joined to the coupling head of the control line of the service brake. During this test a volume of $385 \pm 5 \text{ cm}^3$ (which is deemed to be equivalent to the volume of a pipe 2.5 m long with an internal diameter of 13 mm and under a pressure of 6.5 bar) shall be connected to the coupling head of the supply line.

Tractive units for semi-trailers must be equipped with flexible pipes for making the connection to semi-trailers. The coupling heads will therefore be at the extremity of those flexible pipes. The length and internal diameter of the pipes shall be entered at item 14.6 of the document corresponding to the model described in Annex IX.’

Item 3.2 the second sentence shall be deleted.

Item 3.3.1 shall read:

- ‘3.3.1. It must have a reservoir with a capacity of 30 litres which shall be charged to a pressure of 6.5 bar before each test and which must not be recharged during each test. At the outlet of the braking control device the simulator must incorporate an orifice with a diameter of from 4.0 to 4.3 mm inclusive. The volume of the pipe measured from the orifice up to and including the coupling head shall be $385 \pm 5 \text{ cm}^3$ (which is deemed to be equivalent to the volume of a pipe 2.5 m long with an internal diameter of 13 mm and under a pressure of 6.5 bar). The control line pressures referred to in item 3.3.3 shall be measured immediately downstream of the orifice.’

Item 3.3.2 shall read:

- ‘3.3.2. The braking control device must be so designed that its performance in use is not affected by the tester.’

After item 3.3.2 the following new items 3.3.3 and 3.3.4 shall be added:

- ‘3.3.3. The simulator must be set, e.g. through the choice of orifice in accordance with item 3.3.1, in such a way that, if a reservoir of $385 \pm 5 \text{ cm}^3$ is joined to it, the time taken for the pressure to increase from 0.65 to 4.9 bar (10 and 75% respectively of the nominal pressure of 6.5 bar), shall be 0.2 ± 0.01 second. If a reservoir of $1\,155 \pm 15 \text{ cm}^3$ is substituted for the abovementioned reservoir, the time taken for the pressure to increase from 0.65 to 4.9 bar without further adjustment shall be 0.38 ± 0.02 second. Between these two pressure values the pressure must increase in an approximately linear way. These reservoirs shall be connected to the coupling head without using flexible pipes and shall have an internal diameter of not less than 10 mm.
- 3.3.4. The diagram in the Appendix to this Annex gives an example of the correct configuration and use of the simulator.’

Item 3.4 shall read:

- ‘3.4. The time elapsing between the moment when the pressure produced in the control line by the simulator reaches 0.65 bar and the moment when the pressure in the brake actuator of the trailer reaches 75% of its asymptotic value must not exceed 0.4 second.’

After item 3.4 the following new item 4 shall be added:

- ‘4. PRESSURE TEST CONNECTIONS
- 4.1. On each independent circuit of the braking system a pressure test connection shall be fitted as closely as

▼B

possible to the brake cylinder which is the least favourably placed as far as reaction time is concerned.

- 4.2. The pressure test connections shall comply with ISO Standard 3583/1975.'

APPENDIX: The simulator sketch shall be replaced by the following:

▼B

APPENDIX

EXAMPLE OF A SIMULATOR (SEE ANNEX III, ITEM 3)

1. Setting the simulator

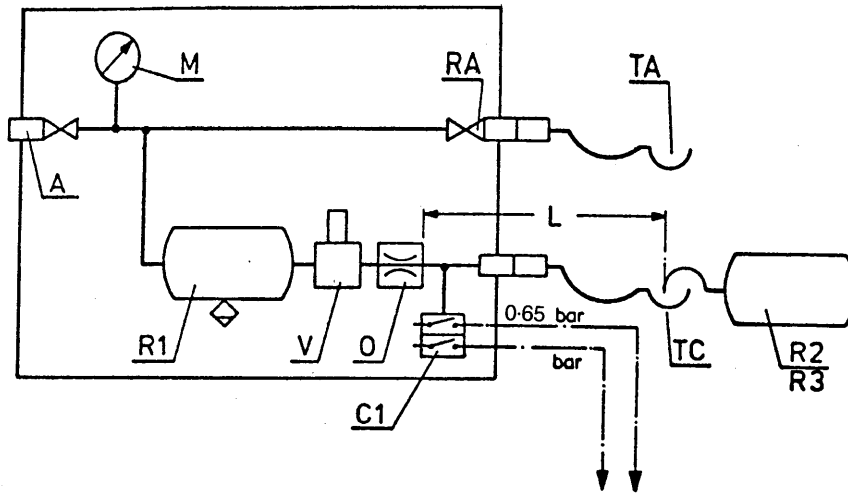

To the electric chronometer

2. Testing the trailer

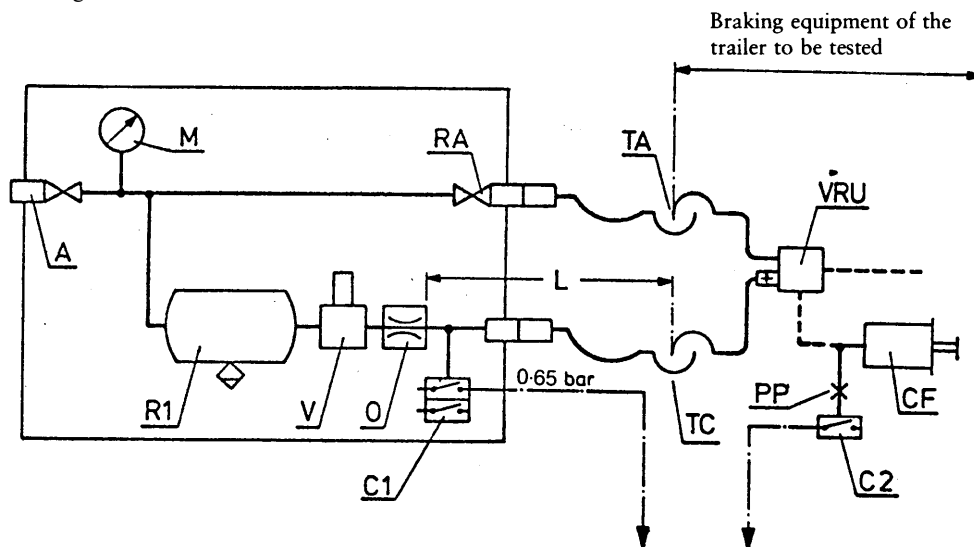

To the electric chronometer

- A = supply connection with shut-off valve
- C1 = pressure switch in the simulator, set at 0.65 bar and at 4.9 bar
- C2 = pressure switch to be connected to the brake actuator of the trailer, to operate at 75% of the asymptotic pressure in the brake actuator CF
- CF = brake actuator
- L = line from orifice O up to and including its coupling head TC, having an inner volume of $385 \pm 5 \text{ cm}^3$ under a pressure of 6.5 bar
- M = pressure gauge
- O = orifice with a diameter of not less than 4 mm and not more than 4.3 mm
- PP = pressure test connection
- R1 = 30 litre air reservoir with drain valve
- R2 = calibrating reservoir, including its coupling head TC, to be $385 \pm 5 \text{ cm}^3$

▼B

- R3 = calibrating reservoir, including its coupling head TC, to be
1 155 ± 15 cm³
- RA = shut-off valve
- TA = coupling head, supply line
- TC = coupling head, control line
- V = braking control device
- VRU = emergency relay valve

ANNEX IV: ENERGY RESERVOIRS AND SOURCES OF ENERGY FOR COMPRESSED AIR BRAKES

Item 1.2.1 shall read:

- ‘1.2.1. The air brake reservoirs of motor vehicles shall be so designed that after eight full-stroke actuations of the service brake control the pressure remaining in the air brake reservoir shall be not less than the pressure required to obtain the specified secondary braking performance.’

After item 2.5 the following new item 3 shall be added:

- ‘3. PRESSURE TEST CONNECTIONS
- 3.1. A pressure test connection must be fitted close to the least favourably placed reservoir within the meaning of item 2.4 of this Annex.
- 3.2. The pressure test connections must comply with ISO Standard 3583/1975.’

ANNEX V: SPRING BRAKES

Item 2.3 add at the end:

‘This item does not apply to trailers.’

Item 2.4 shall read:

- ‘2.4. In motor vehicles, the system must be so designed that it is possible to apply and release the brakes at least three times if the initial pressure in the spring compression chamber is equal to the maximum design pressure. In the case of trailers, it must be possible to release the brakes at least three times after the trailer has been uncoupled, the pressure in the supply line being 6.5 bar before the uncoupling. These conditions must be satisfied when the brakes are adjusted as closely as possible. In addition, it must be possible to apply and release the parking brake as specified in Annex I, item 2.2.2.10, when the trailer is coupled to the towing vehicle.’

Item 2.5 add at the end:

‘In the case of trailers, this pressure level (pm) is the pressure which is obtained after four full-stroke actuations of the service brake in accordance with Annex IV, item 1.3. The initial pressure is fixed at 6.5 bar.’

Item 2.6 add at the end:

‘This provision does not apply to trailers.’

ANNEX VI: PARKING BRAKING BY MECHANICAL LOCKING OF THE BRAKE CYLINDERS

Item 2.1 add at the end:

‘This provision shall not apply to trailers. In the case of trailers the pressure corresponding to mechanical locking must not exceed 4 bar. It must be possible to achieve parking brake performance after any single failure of the trailer service braking system. In addition, it must be possible to release the brakes at least three times after the trailer has been uncoupled, the pressure in the supply line being 6.5 bar before the uncoupling. These conditions must be satisfied when the brakes are adjusted as closely as possible. It must also be possible to apply and release the parking brake as

▼B

specified in Annex I, item 2.2.2.10, when the trailer is coupled to the towing vehicle.’

After item 2.4 the following new item 2.5 shall be added:

- ‘2.5. The control must be such that, when actuated, it performs the following operations in sequence: it applies the brakes so as to provide the degree of efficiency required for parking braking, locks the brakes in that position and then cancels out the brake-application force.’

ANNEX IX

The title shall read:

‘MODEL

ANNEX TO THE EEC VEHICLE TYPE-APPROVAL CERTIFICATE CONCERNING BRAKING DEVICES

(Articles 4 (2) and 10 of Council Directive 70/156/EEC of 6 February 1970 on the approximation of the laws of the Member States relating to the type-approval of motor vehicles and their trailers

Taking into account the amendments introduced pursuant to Directive 79/489/EEC’

Footnote ⁽³⁾ concerning item 14.3 shall read:

- ‘⁽³⁾ Applies only to vehicles of categories O₂, O₃ and O₄.’

Item 14.6 shall read:

- ‘14.6. Response time and dimensions of flexible pipes
 14.6.1. Response time at the brake actuator ... s
 14.6.2. Response time at the control line coupling head ... s
 14.6.3. Flexible pipes of tractive units for semi-trailers:
 — length: ... m,
 — internal diameter ... mm.’

In item 17 a new item 17 (a) 2 shall be added:

- ‘17 (a) 2 Information required in item 7.3 of the Appendix to item 1.1.4.2 of Annex II.’

Annex to Commission Directive 75/524/EEC of 25 July 1975

Appendix to item 1.1.4.2 (Annex II):

DISTRIBUTION OF BRAKING EFFORT AMONG VEHICLE AXLES.

Item 3.1.2 shall read:

- ‘3.1.2. In the case of a vehicle authorized to draw trailers of category O₃ or O₄ fitted with air brakes, the pressure at full application of the braking control must be between 6.5 and 8 bar at the coupling head of the supply line and between 6 and 7.5 bar at the coupling head of the control line, irrespective of the load condition of the vehicle. These pressures must be demonstrably present in the drawing vehicle when uncoupled from the trailer.’

Item 6 shall read:

- ‘6. **CONDITIONS TO BE FULFILLED IN THE CASE OF FAILURE OF THE BRAKING DISTRIBUTION SYSTEM**

When the requirements of this Appendix are fulfilled by means of a special device (e.g. controlled mechanically by the suspension of the vehicle), it shall be possible, in the event of the failure of this device or its means of control, to stop the vehicle under the conditions specified for secondary braking in the case of motor vehicles; for those vehicles authorized to draw a trailer fitted with air brakes, it must be possible to achieve a pressure at the coupling head of the control line within the range specified in item 3.1.2 of

▼B

this Appendix. In the event of failure of the means of controlling the device in trailers and semi-trailers, a braking rate of at least 30% of the service brake performance prescribed for the vehicle in question shall be attained.'

Item 7 shall read:

- '7. MARKINGS
- 7.1. Vehicles, other than those of category M₁, which meet the requirements of this Appendix by means of a device mechanically controlled by the suspension of the vehicle, shall be marked to show the useful travel of the device between the positions corresponding to vehicle unladen und laden states respectively and any further information to enable the setting of the device to be checked.
- 7.1.1. When a brake load sensing device is controlled via the suspension of the vehicle by any other means, the vehicle must be marked with information to enable the setting of the device to be checked.
- 7.2. When the requirements of this Appendix are met by means of a device which modulates the air pressure in the brake transmission, the vehicle must be marked to show a mass corresponding to the axle loads at the ground, the nominal outlet pressures of the device and an inlet pressure of not less than 80% of the maximum design inlet pressure, as declared by the vehicle manufacturer, for the following states of load:
- 7.2.1. Technically permissible maximum load on the axle(s) which control(s) the device.
- 7.2.2. Axle load(s) corresponding to the mass of the vehicle in running order as defined in item 2.6 of Annex I to Directive 70/156/EEC.
- 7.2.3. The axle load(s) approximating to the vehicle with proposed bodywork in running order where the axle load(s) mentioned in item 7.2.2 relate(s) to the vehicle chassis with cab.
- 7.2.4. The axle load(s) designated by the manufacturer to enable the setting of the device to be checked in service if this is (these are) different from the loads specified in items 7.2.1, 7.2.2 and 7.2.3.
- 7.3. Item 17 (a) 2 of Annex IX must include information to enable compliance with the requirements of items 7.1 and 7.2 to be checked.
- 7.4. The markings referred to under items 7.1 and 7.2 must be affixed in a visible position in indelible form. An example of the markings for a mechanically controlled device in a vehicle fitted with compressed air braking is shown in Diagram 5.'

Item 8 shall read:

- '8. PRESSURE TEST CONNECTIONS

Braking systems incorporating the devices referred to in item 7.2 shall be fitted with pressure test connections which conform with ISO Standard 3583/1975 in the pressure line upstream and downstream of the device.'

The former item 8 becomes item 9.

In Diagrams 2 and 4A, $\frac{TR}{PM}$, shall be replaced by $\frac{TR}{PR}$, in the ordinate.

▼B

After Diagram 4B, a new Diagram 5 shall be added as follows:

DIAGRAM 5
BRAKE LOAD SENSING DEVICE
 (see item 7.4)

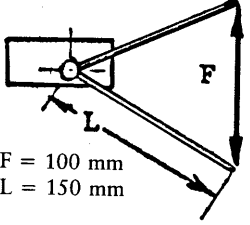
Control data	Vehicle loading	Axle No 2 -load at the ground (kg)	Inlet pressure (bar)	Nominal outlet pressure (bar)
 <p>F = 100 mm L = 150 mm</p>	Laden	10 000	6	6
	Unladen	1 500	6	2.4

