

COMMISSION DIRECTIVE 2000/2/EC

of 14 January 2000

adapting to technical progress Council Directive 75/322/EEC relating to the suppression of radio interference produced by spark-ignition engines fitted to wheeled agricultural or forestry tractors and Council Directive 74/150/EEC relating to the type-approval of wheeled agricultural or forestry tractors

(Text with EEA relevance)

THE COMMISSION OF THE EUROPEAN COMMUNITIES,

Having regard to the Treaty establishing the European Community,

Having regard to Council Directive 74/150/EEC of 4 March 1974 on the approximation of the laws of the Member States relating to the type-approval of wheeled agricultural or forestry tractors ⁽¹⁾, as last amended by European Parliament and Council Directive 97/54/EC ⁽²⁾, and in particular Article 11 thereof,

Having regard to Council Directive 75/322/EEC of 20 May 1975 on the approximation of the laws of the Member States relating to the suppression of radio interference produced by spark-ignition engines fitted to wheeled agricultural or forestry tractors ⁽³⁾, as last amended by Directive 97/54/EC, and in particular Article 5 thereof,

Whereas:

- (1) Directive 75/322/EEC is one of the separate directives of the EC type-approval procedure which was established pursuant to Directive 74/150/EEC. Consequently, the provisions laid down in Directive 74/150/EEC applicable to systems, components and separate technical units apply to Directive 75/322/EEC.
- (2) Directive 75/322/EEC contains the earliest measures endeavouring to bring about a basic electromagnetic compatibility regarding radio interference. Subsequently, technical progress has increased the complexity and diversity of electrical and electronic equipment.
- (3) To take account of the increasing concern about the technological developments in electrical and electronic equipment and the need to ensure the general compatibility of different electrical and electronic equipment, Council Directive 89/336/EEC ⁽⁴⁾, as last amended by Directive 93/68/EEC ⁽⁵⁾, laid down general provisions regarding electromagnetic compatibility for all products not covered by a specific directive.
- (4) Directive 89/336/EEC established the principle that, in so far as protection requirements specified in that Directive were harmonised, its general provisions would

not apply or would cease to apply with regard to apparatus covered by specified directives.

- (5) Directive 75/322/EEC should become such a specific directive.
- (6) The adaptation to technical progress was effected, in the case of motor vehicles, by Commission Directive 95/54/EC ⁽⁶⁾ relating to the suppression of radio interference produced by spark-ignition engines fitted to motor vehicles. Equivalent requirements must now be adopted on the suppression of radio interference produced by engines fitted to agricultural or forestry tractors, by establishing a specific directive within the framework of the type-approval procedure which provides for approvals granted by designated national authorities on the basis of harmonised technical requirements.
- (7) From 1 October 2001 the technical requirements relating to the radio interference (electromagnetic compatibility) of vehicles, their components and systems should be governed solely by the provisions of Directive 75/322/EEC.
- (8) The measures provided for in this Directive are in accordance with the opinion of the Committee for Adaptation to Technical Progress established by Article 12 of Directive 74/150/EEC,

HAS ADOPTED THIS DIRECTIVE:

Article 1

Directive 75/322/EEC is amended as follows:

1. The title is replaced by the following:

‘Council Directive 75/322/EEC of 20 May 1975 on the suppression of radio interference produced by agricultural or forestry tractors (electromagnetic compatibility).’

2. Articles 1 and 2 are replaced by the following:

‘Article 1

For the purposes of this Directive, “vehicle” means any vehicle as defined in Directive 74/150/EEC.

⁽¹⁾ OJ L 84, 28.3.1974, p. 10.

⁽²⁾ OJ L 277, 10.10.1997, p. 24.

⁽³⁾ OJ L 147, 9.6.1975, p. 28.

⁽⁴⁾ OJ L 139, 23.5.1989, p. 19.

⁽⁵⁾ OJ L 220, 30.8.1993, p. 1.

⁽⁶⁾ OJ L 266, 8.11.1995, p. 1.

Article 2

No Member State may refuse to grant EC type-approval or national type-approval to a vehicle, system, component or separate technical unit on grounds relating to electromagnetic compatibility if the requirements of this Directive are fulfilled.'

3. Article 3 is deleted.

4. Article 4 is replaced by the following:

'Article 4

This Directive shall constitute a "specific directive" for the purposes of Article 2(2) of Council Directive 89/336/EEC (*) with effect from 1 October 2001.

(*) OJ L 139, 23.5.1989, p. 19.'

5. The Annexes shall be replaced by Annexes I to IX to Directive 95/54/EC, subject to the amendments set out in the Annex to this Directive.

Article 2

1. With effect from 1 January 2001, Member States may not, on grounds relating to electromagnetic compatibility:

- refuse to grant EC type-approval or national type-approval in respect of any given type of vehicle,
- refuse to grant EC component or technical unit type-approval in respect of any given type of component or separate technical unit,
- prohibit the registration, sale or entry into service of vehicles,
- prohibit the sale or use of components or separate technical units,

if the vehicles, components or separate technical units comply with the requirements of Directive 75/322/EEC, as amended by this Directive.

2. With effect from 1 October 2002, Member States:

- may no longer grant EC vehicle type-approval, EC component type-approval or EC separate technical unit type-approval,
- and
- may refuse to grant national type-approval,

for any type of vehicle component or separate technical unit, if the requirements of Directive 75/322/EEC, as amended by this Directive, are not fulfilled.

3. Paragraph 2 shall not apply to vehicle types approved before 1 October 2002 pursuant to Council Directive 77/

537/EEC (1) nor to any subsequent extensions to these approvals.

4. With effect from 1 October 2008, Member States:

- shall consider certificates of conformity which accompany new vehicles in accordance with the provisions of Directive 74/150/EEC to be no longer valid for the purposes of Article 7(1) of that Directive,
- and
- may refuse the sale and entry into service of new electrical or electronic sub-assemblies as components or separate technical units,

if the requirements of this Directive are not fulfilled.

5. Without prejudice to paragraphs 2 and 4, in the case of replacement parts, Member States shall continue to grant EC type-approval and to permit the sale and entry into service of components or separate technical units intended for use on vehicle types which have been approved before 1 October 2002 pursuant to Directive 75/322/EEC or Directive 77/537/EEC and, where applicable, subsequent extensions to these approvals.

Article 3

In point 3.17 of Annex I and point 2.4 of Annex II to Directive 74/150/EEC, 'interference suppressor' is replaced by 'electromagnetic compatibility'.

Article 4

1. Member States shall bring into force the laws, regulations and administrative provisions necessary to comply with this Directive by 31 December 2000 at the latest. They shall forthwith inform the Commission thereof.

When Member States adopt those provisions, they shall contain a reference to this Directive or be accompanied by such a reference on the occasion of their official publication. Member States shall determine how such reference is to be made.

2. Member States shall communicate to the Commission the texts of the main provisions of national law which they adopt in the field covered by this Directive.

Article 5

This Directive shall enter into force on the 20th day following that of its publication in the *Official Journal of the European Communities*.

(1) OJ L 220, 29.8.1977, p. 38.

Article 6

This Directive is addressed to the Member States.

Done at Brussels, 14 January 2000.

For the Commission

Erkki LIIKANEN

Member of the Commission

ANNEX

For the purposes of this Directive, Annexes I, IIA, IIB, IIIA, IIIB, IV and VI to Directive 95/54/EC are hereby amended as follows:

1. **Annex I**

1.1. Point 1.1 shall read as follows:

'This Directive applies to the electromagnetic compatibility of vehicles covered by Article 1. It also applies to electrical or electronic separate technical units intended to be fitted to the vehicles.'

1.2. In point 2.1.10:

'Directive 70/156/EEC, Article 2' shall be replaced by 'Directive 74/150/EEC, Article 9a'.

1.3. In points 3.1.1 and 3.2.1:

'Article 3(4) of Directive 70/156/EEC' shall be replaced by 'Article 9a of Directive 74/150/EEC'.

1.4. In points 4.2.1.1 and 4.2.2.1:

'Article 4(3) and, if applicable, Article 4(4) of Directive 70/156/EEC' shall be replaced by 'Article 4 of Directive 74/150/EEC'.

1.5. In point 4.3.1:

'Article 5 of Directive 70/156/EEC' shall be replaced by 'Article 6 of Directive 74/150/EEC'.

1.6. In point 5.2:

1.6.1. The 11 indents shall be replaced by the following:

'1 for Germany; 2 for France; 3 for Italy; 4 for the Netherlands; 5 for Sweden; 6 for Belgium; 9 for Spain; 11 for the United Kingdom; 12 for Austria; 13 for Luxembourg; 17 for Finland; 18 for Denmark; 21 for Portugal; 23 for Greece; 24 for Ireland.'

1.6.2. 'Directive 72/245/EEC' shall be replaced by 'Directive 75/322/EEC'.

1.7. Points 7.1 and 7.3 shall be deleted.

2. **Annex IIA**

2.1. The title shall be replaced by:

'Information document No... pursuant to Annex I to Directive 74/150/EEC relating to EC type-approval of a vehicle with respect to electromagnetic compatibility (Directive 75/322/EEC), as last amended by Directive 2000/2/E'.

2.2. The footnote (*) shall be deleted.

3. **Annex IIB**

3.1. The title shall be replaced by:

'Information document No... relating to EC type-approval of an electrical/electronic sub-assembly with respect to electromagnetic compatibility (Directive 75/322/EEC), as last amended by Directive 2000/2/EC'.

4. **Annex IIIA**

4.1. The title shall be replaced by:

'EC TYPE-APPROVAL CERTIFICATE'.

4.2. In the first paragraph:

'Directive 72/245/EEC' shall be replaced by 'Directive 75/322/EEC'.

- 4.3. In point 0.4:
- 4.3.1. 'Category of vehicle (³)' shall be replaced by 'Vehicle.'
- 4.3.2. Footnote (³) shall be deleted.
- 4.4. The title of the Appendix shall be replaced by:
'Appendix to EC type-approval certificate No... concerning the type-approval of a vehicle with regard to Directive 75/322/EEC, as last amended by Directive 2000/2/EC.'
5. **Annex IIIB**
- 5.1. The title shall be replaced by
'EC TYPE-APPROVAL CERTIFICATE'.
- 5.2. In the first paragraph:
'Directive 72/245/EEC' shall be replaced by 'Directive 75/322/EEC'.
- 5.3. In point 0.4:
- 5.3.1. 'Category of vehicle (³)' shall be replaced by 'Vehicle.'
- 5.3.2. Footnote shall (³) be deleted.
- 5.4. The title of the Appendix shall be replaced by:
'Appendix to EC type-approval certificate No... concerning the type-approval of an electrical/electronic sub-assembly with regard to Directive 75/322/EEC, as last amended by Directive 2000/2/EC.'
6. **Annex IV**
- 6.1. The first subparagraph of point 1.3 shall be amended as follows:
'This test is intended to measure the broadband electromagnetic emissions generated by spark-ignition systems and by electric motors (electric traction motors, engines for heating or de-icing systems, fuel pumps, water pumps, etc.) permanently fitted to the vehicle.'
- 6.2. The following shall be added to point 5.3:
'and in line with the vehicle mid-point defined as the point on the principal axis of the vehicle midway between the centres of the front and rear axles of the vehicle.'
- 6.3. In Appendix 1, Figures 1 and 2 shall be replaced by the following figures:

Figure 1
TRACTOR TEST AREA
(Level area free from reflecting electromagnetic surfaces)

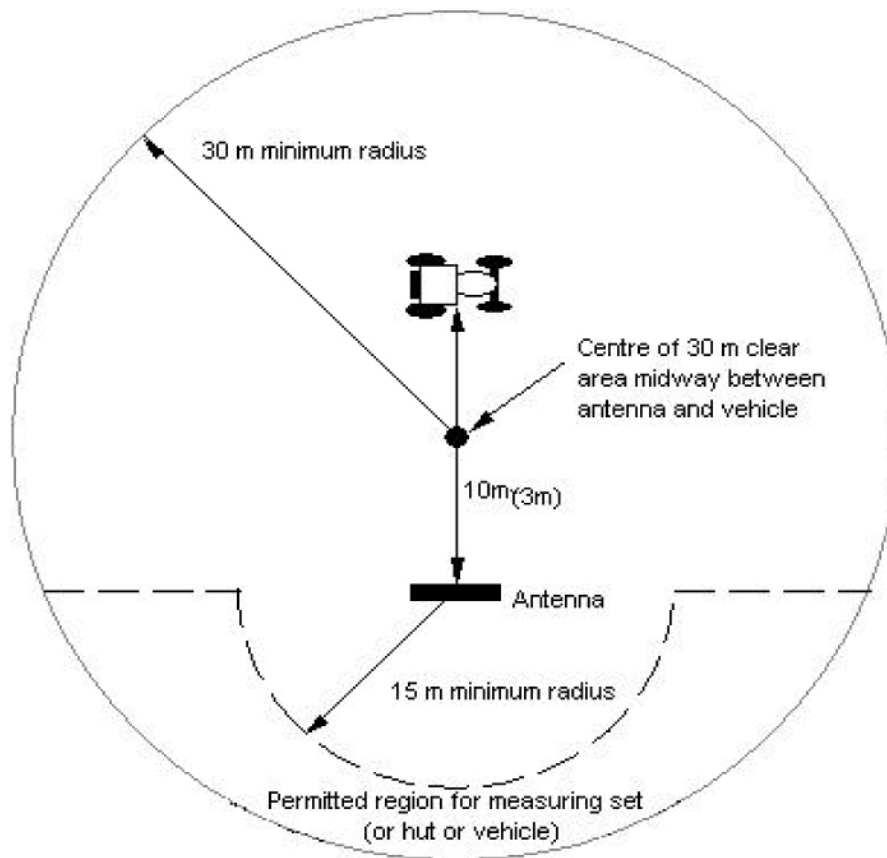
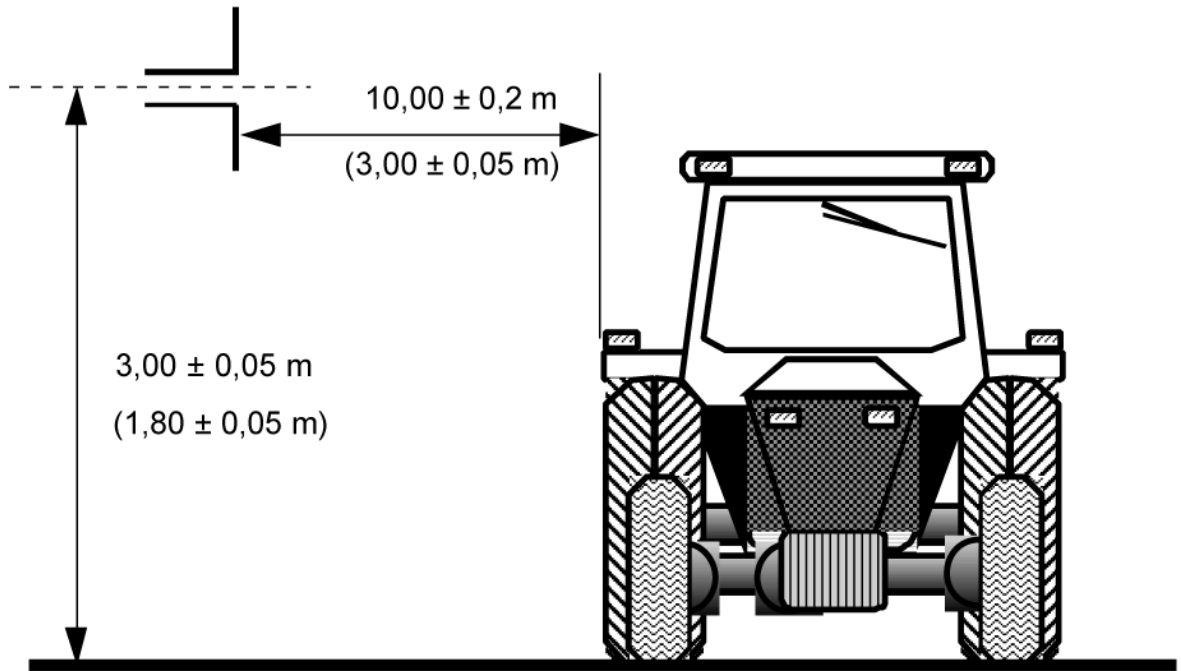

Figure 2

POSITION OF ANTENNA RELATIVE TO TRACTOR



Elevation

Dipole antenna in position to measure vertical component of radiation

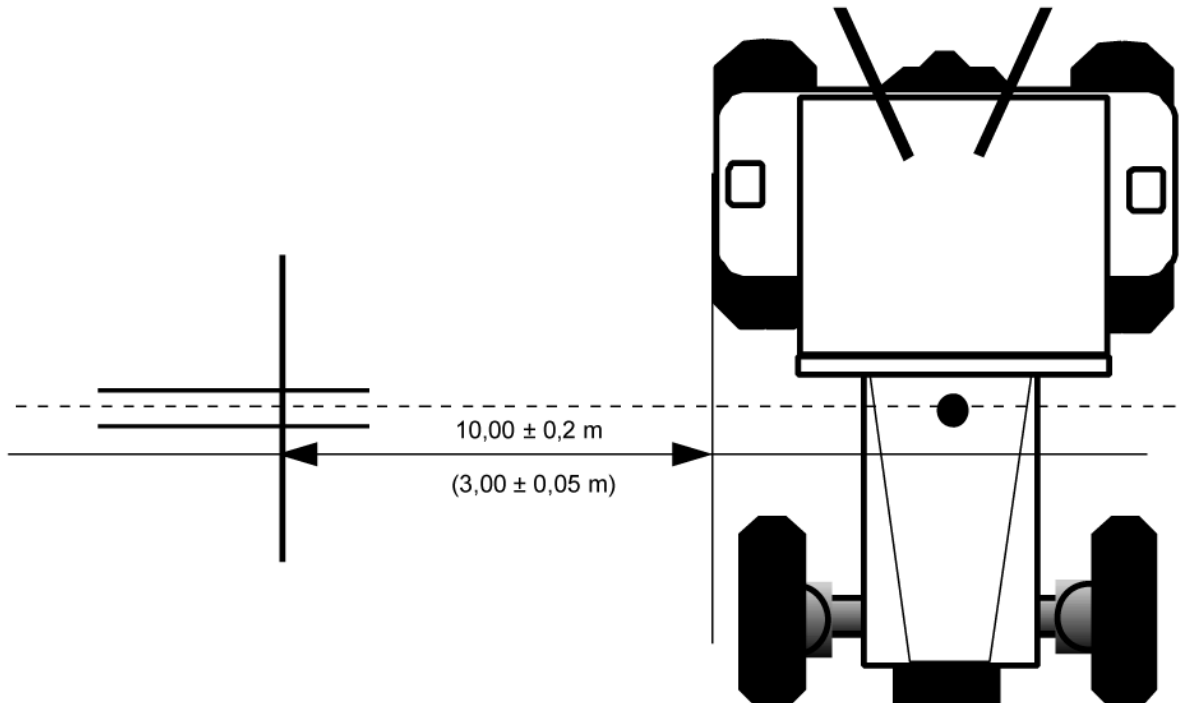

Plan

Dipole antenna in position to measure horizontal component of radiation

7. **Annex IV**

7.1. Point 4.1.1 shall be amended as follows:

'The engine shall turn the driving wheels normally at a constant speed corresponding to three quarters of the maximum speed of the vehicle if there is no technical reason for the manufacturer to prefer another speed. The vehicle's engine must be loaded with an appropriate torque. If need be, the transmission shafts may be disengaged (for example, in the case of vehicles with more than two axles), provided they do not drive a component emitting interference.'

7.2. Point 5.4.1.4 shall be amended as follows:

'5.4.1.4. for front illumination, either:

- $\pm 0,2$ m inside the vehicle, measured from the point of intersection of the windscreen and bonnet (point C in Appendix 1 to this Annex), or
 - $0,2 \pm 0,2$ m from the centre line of the front axle of the tractor measured towards the centre of the tractor (point D in Appendix 2 to this Annex),
- whichever results in a reference point closer to the antenna.'

7.3. A new paragraph shall be added as follows:

'5.4.1.5. for rear illumination, either:

- $\pm 0,2$ m inside the vehicle, measured from the point of intersection of the windscreen and bonnet (point C in Appendix 1 to this Annex), or
 - $0,2 \pm 0,2$ m from the centre line of the rear axle of the tractor, measured towards the centre of the tractor (point D in Appendix 2 to this Annex),
- whichever results in a reference point closer to the antenna.'

7.4. Appendices 1 and 2 shall be replaced by the following:

'Appendix 1

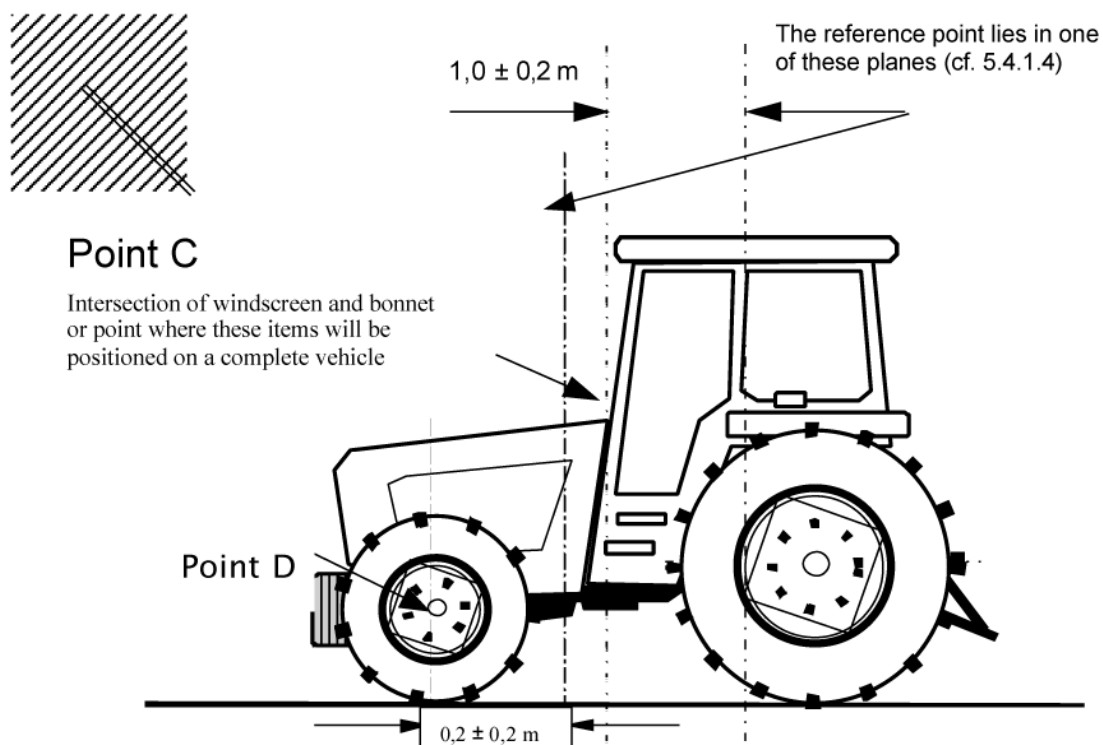

Appendix 2

The reference point lies in one of these planes (cf. 5.4.1.5)

$0,20 \pm 0,2$ m

Intersection of windscreen and bonnet or point where these items will be positioned on a complete tractor:

Point C

Point D
Rear axle

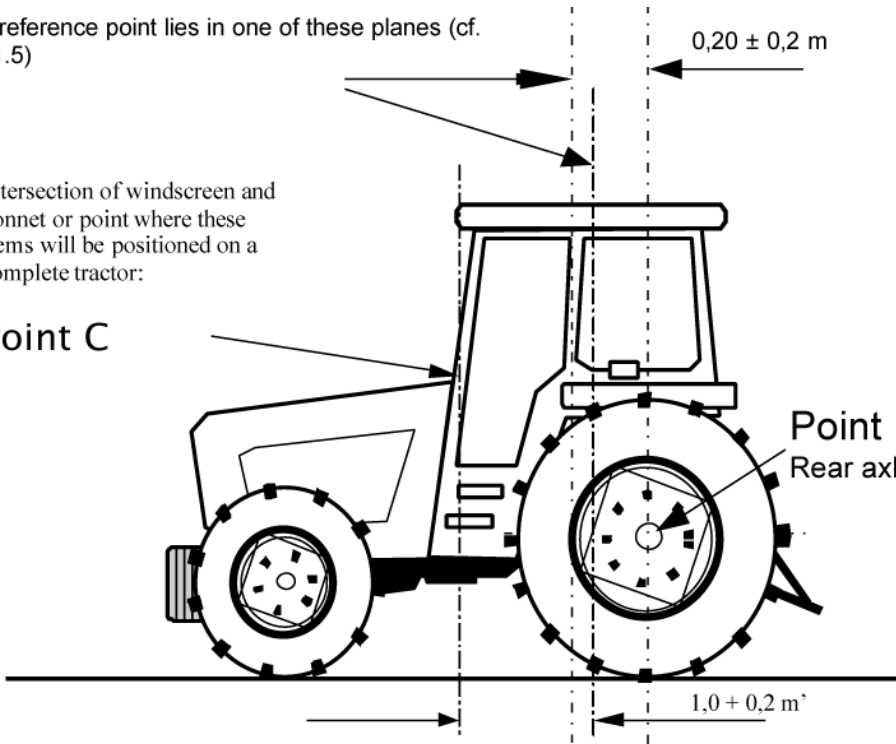

- 7.5. Appendix 3 shall be deleted.
- 7.6. Appendix 4 shall be renumbered Appendix 3.