

Directive 2007/46/EC of the European Parliament and of the Council of 5 September 2007 establishing a framework for the approval of motor vehicles and their trailers, and of systems, components and separate technical units intended for such vehicles (Framework Directive) (Text with EEA relevance) (repealed)

DIRECTIVE 2007/46/EC OF THE EUROPEAN  
PARLIAMENT AND OF THE COUNCIL

of 5 September 2007

establishing a framework for the approval of motor vehicles and their trailers, and of systems, components and separate technical units intended for such vehicles

(Framework Directive)

(Text with EEA relevance) (repealed)

THE EUROPEAN PARLIAMENT AND THE COUNCIL OF THE EUROPEAN UNION,

Having regard to the Treaty establishing the European Community, and in particular Article 95 thereof,

Having regard to the proposal from the Commission,

Having regard to the opinion of the European Economic and Social Committee<sup>(1)</sup>,

Acting in accordance with the procedure referred to in Article 251 of the Treaty<sup>(2)</sup>,

Whereas:

- (1) Council Directive 70/156/EEC of 6 February 1970 on the approximation of the laws of the Member States relating to the type-approval of motor vehicles and their trailers<sup>(3)</sup>, has been substantially amended several times. Since further amendments are to be made, it should be recast in the interests of clarity.
- (2) For the purposes of the establishment and operation of the internal market of the Community, it is appropriate to replace the Member States' approval systems with a Community approval procedure based on the principle of total harmonisation.
- (3) The technical requirements applicable to systems, components, separate technical units and vehicles should be harmonised and specified in regulatory acts. Those regulatory acts should primarily seek to ensure a high level of road safety, health protection, environmental protection, energy efficiency and protection against unauthorised use.
- (4) Council Directive 92/53/EEC of 18 June 1992 amending Directive 70/156/EEC on the approximation of the laws of the Member States relating to the type-approval of motor vehicles and their trailers<sup>(4)</sup> limited application of the Community whole vehicle type-approval procedure to the vehicle category M<sub>1</sub>. However, in order to complete the internal market and to ensure that it functions properly, the scope of the present Directive should cover all categories of vehicles, enabling manufacturers to benefit from the advantages of the internal market by means of the Community type-approval.

---

*Status: EU Directives are being published on this site to aid cross referencing from UK legislation. After IP completion day (31 December 2020 11pm) no further amendments will be applied to this version.*

---

- (5) In order to enable manufacturers to adapt to the new harmonised procedures, a sufficient lead-time should be allowed before Community vehicle type-approval becomes compulsory for vehicles belonging to categories other than M<sub>1</sub> that are built in one stage. A longer lead-time is required for vehicles of categories other than M<sub>1</sub> that require a multi-stage approval, since that procedure will involve body-builders, who will need to gain sufficient experience in that field so that the necessary procedures can be implemented properly. However, due to the importance of safety for vehicles of category M<sub>2</sub> and M<sub>3</sub>, during the transitional period when national type approval is still valid in order to allow manufacturers to get experience with EC vehicle type approval, it is necessary that those vehicles comply with the technical requirements of the harmonised directives.
- (6) Until now, manufacturers who produce vehicles in small series have been partially excluded from the benefits of the internal market. Experience has shown that road safety and protection of the environment could be significantly improved if small series vehicles were totally integrated into the Community vehicle type-approval system, starting with category M<sub>1</sub>.
- (7) In order to prevent abuse, any simplified procedure for small series vehicles should be restricted to cases of very limited production; it is therefore necessary to define more precisely the concept of small series in terms of the number of vehicles produced.
- (8) It is important to lay down measures enabling vehicles to be approved on an individual basis, in order to allow sufficient flexibility in the multi-stage approval system; however, pending the establishment of harmonised, specific Community provisions, Member States should continue to be allowed to grant individual approvals in accordance with their national rules.
- (9) Pending application of the Community vehicle type-approval procedures to categories of vehicles other than M<sub>1</sub>, Member States should be allowed to continue to grant vehicle type-approvals on a national basis, and transitional provisions should be laid down accordingly.
- (10) The measures necessary for the implementation of this Directive should be adopted in accordance with Council Decision 1999/468/EC of 28 June 1999 laying down the procedures for the exercise of implementing powers conferred on the Commission<sup>(5)</sup>.
- (11) By Council Decision 97/836/EC<sup>(6)</sup>, the Community acceded to the Agreement of the United Nations Economic Commission for Europe concerning the adoption of uniform technical prescriptions for wheeled vehicles, equipment and parts which can be fitted to and/or used on wheeled vehicles and the conditions for reciprocal recognition of approvals granted on the basis of these prescriptions (Revised 1958 Agreement). Consequently, United Nations Economic Commission for Europe (UNECE) Regulations to which the Community accedes, in application of that Decision, and amendments to UNECE Regulations to which the Community has already acceded should be incorporated within the Community type-approval procedure either as requirements for EC vehicle type-approval, or as alternatives to existing Community law. In particular, where the Community decides, by means of a Council decision, that

---

*Status: EU Directives are being published on this site to aid cross referencing from UK legislation. After IP completion day (31 December 2020 11pm) no further amendments will be applied to this version.*

---

a UNECE Regulation shall become part of the EC vehicle type-approval procedure and replace existing Community law, the Commission should be empowered to make the necessary adaptations to this Directive. Since those measures are of general scope and are designed to amend non-essential elements of this Directive or to supplement it by the addition of new non-essential elements, they should be adopted in accordance with the regulatory procedure with scrutiny provided for in Article 5a of Decision 1999/468/EC.

- (12) For the purposes of better regulation and simplification and in order to avoid having to constantly update existing Community legislation on issues of technical specifications, it should be possible for this Directive or for separate directives and regulations to make references to existing international standards and regulations without reproducing them in the Community legal framework.
- (13) In order to ensure that the procedure for monitoring conformity of production, which is one of the cornerstones of the Community type-approval system, has been correctly implemented and functions properly, manufacturers should be regularly checked by the competent authority or by an appropriately qualified technical service appointed for that purpose.
- (14) The main objective of the legislation on the approval of vehicles is to ensure that new vehicles, components and separate technical units put on the market provide a high level of safety and environmental protection. This aim should not be impaired by the fitting of certain parts or equipment after vehicles have been placed on the market or have entered service. Thus, appropriate measures should be taken in order to make sure that parts or equipment which can be fitted to vehicles and which are capable of significantly impairing the functioning of systems that are essential in terms of safety or environmental protection, are subject to a prior control by an approval authority before they are offered for sale. These measures should consist of technical provisions concerning the requirements that those parts or equipment have to comply with.
- (15) These measures should only apply to a limited number of parts or equipment. The list of such parts or equipment and subsequent requirements should be established after having consulted stakeholders. In establishing the list, the Commission should consult stakeholders on the basis of a report and strive for a fair balance between the requirements of improving road safety and environmental protection, as well as the interests of consumers, manufacturers and distributors in preserving competition in the aftermarket.
- (16) The list of parts and equipment, the essential systems concerned as well as the testing and implementation measures should be determined in accordance with Decision 1999/468/EC. Since those measures are of general scope and are designed to amend non-essential elements of this Directive or to supplement it by the addition of new non-essential elements, they should be adopted in accordance with the regulatory procedure with scrutiny provided for in Article 5a of that Decision.
- (17) This Directive constitutes a set of specific safety requirements within the meaning of Article 1(2) of Directive 2001/95/EC of the European Parliament and of the Council of 3 December 2001 on general product safety<sup>(7)</sup>, laying down specific requirements for protecting the health and safety of consumers. Therefore, it is important to establish

---

*Status: EU Directives are being published on this site to aid cross referencing from UK legislation. After IP completion day (31 December 2020 11pm) no further amendments will be applied to this version.*

---

provisions to ensure that, in case a vehicle presents a serious risk for consumers resulting from the application of this Directive or of the regulatory acts listed in Annex IV, the manufacturer has taken effective protective measures, including the recall of vehicles. Approval authorities should therefore be able to assess whether the proposed measures are sufficient or not.

- (18) It is important that manufacturers supply relevant information to vehicle owners in order to prevent misuse of safety devices. It is appropriate to include provisions thereon in this Directive.
- (19) It is also important for equipment manufacturers to have access to certain information that is available only from the vehicle manufacturer, that is to say, the technical information, including drawings, required for the development of parts for the aftermarket.
- (20) It is equally important that manufacturers make information readily available to independent operators to ensure the repairing and maintenance of vehicles in a fully competitive market. These information requirements have so far been incorporated in Community legislation, and in particular in Regulation (EC) No 715/2007 of the European Parliament and of the Council of 20 June 2007 on type approval of motor vehicles with respect to emissions from light passenger and commercial vehicles (Euro 5 and 6) and on access to vehicle repair and maintenance information<sup>(8)</sup>, on the basis that the Commission will present a report, no later than four years after the date of entry into force of that Regulation, on the operation of the system of access to vehicle repair and maintenance information and will consider whether it would be appropriate to consolidate all provisions governing access to such information within a revised framework directive on type approval.
- (21) With the aim of simplifying and accelerating the procedure, measures implementing the separate directives or regulations as well as measures for adapting the annexes to this Directive and the separate directives or regulations, in particular to the development of scientific and technical knowledge, should be adopted in accordance with Decision 1999/468/EC. Since those measures are of general scope and are designed to amend non-essential elements of this Directive or of the separate directives or regulations, or to supplement them by the addition of new non-essential elements, they should be adopted in accordance with the regulatory procedure with scrutiny provided for in Article 5a of that Decision. The same procedure should apply to adaptations needed for the type-approval of vehicles intended for persons with disabilities.
- (22) Experience shows that appropriate measures may have to be taken without delay with a view to ensuring a better protection of road users where shortcomings have been identified in the existing legislation. For such urgent cases, the necessary amendments to the separate directives or regulations should be adopted in accordance with Decision 1999/468/EC. Since those measures are of general scope and are designed to amend non-essential elements of the separate directives or regulations or to supplement them by the addition of new non-essential elements, they should be adopted in accordance with the regulatory procedure with scrutiny provided for in Article 5a of that Decision.

- (23) Since the objective of this Directive, namely the achievement of the internal market through the introduction of a compulsory system of Community type-approval for all categories of vehicles, cannot be sufficiently achieved by the Member States and can, therefore, by reason of the scale of the action, be better achieved at Community level, the Community may adopt measures, in accordance with the principle of subsidiarity as set out in Article 5 of the Treaty. In accordance with the principle of proportionality, as set out in that Article, this Directive does not go beyond what is necessary in order to achieve this objective.
- (24) The obligation to transpose this Directive into national law should be confined to those provisions which represent a substantive change as compared with the earlier Directives. The obligation to transpose the provisions which are unchanged arises under the earlier Directives.
- (25) In accordance with point 34 of the Interinstitutional Agreement on better law-making<sup>(9)</sup>, Member States are encouraged to draw up, for themselves and in the interests of the Community, their own tables illustrating, as far as possible, the correlation between this Directive and the transposition measures, and to make them public.
- (26) This Directive should be without prejudice to the obligations of the Member States relating to the time-limits for transposition into national law and application of the directives set out in Part B of Annex XX.
- (27) The requirements of this Directive are in accordance with the principles enshrined in the Action plan entitled ‘Simplifying and improving the regulatory environment’.
- (28) It is of particular importance that future measures proposed on the basis of this Directive or procedures to be implemented in application of it should comply with these principles, which have been restated by the Commission in its communication on a Competitive Automotive Regulatory framework for the 21st Century,

HAVE ADOPTED THIS DIRECTIVE:

## CHAPTER I

### GENERAL PROVISIONS

#### *Article 1*

#### **Subject matter**

This Directive establishes a harmonised framework containing the administrative provisions and general technical requirements for approval of all new vehicles within its scope and of the systems, components and separate technical units intended for those vehicles, with a view to facilitating their registration, sale and entry into service within the Community.

This Directive also establishes the provisions for the sale and entry into service of parts and equipment intended for vehicles approved in accordance with this Directive.

---

*Status: EU Directives are being published on this site to aid cross referencing from UK legislation. After IP completion day (31 December 2020 11pm) no further amendments will be applied to this version.*

---

Specific technical requirements concerning the construction and functioning of vehicles shall be laid down in application of this Directive in regulatory acts, the exhaustive list of which is set out in Annex IV.

## Article 2

### Scope

1 This Directive applies to the type-approval of vehicles designed and constructed in one or more stages for use on the road, and of systems, components and separate technical units designed and constructed for such vehicles.

It also applies to the individual approval of such vehicles.

This Directive also applies to parts and equipment intended for vehicles covered by this Directive.

2 This Directive does not apply to the type-approval or individual approval of the following vehicles:

- a agricultural or forestry tractors, as defined in Directive 2003/37/EC of the European Parliament and of the Council of 26 May 2003 on type-approval of agricultural or forestry tractors, their trailers and interchangeable towed machinery, together with their systems, components and separate technical units<sup>(10)</sup> and trailers designed and constructed specifically to be towed by them;
- b quadricycles as defined in Directive 2002/24/EC of the European Parliament and of the Council of 18 March 2002 relating to the type-approval of two or three-wheel motor vehicles<sup>(11)</sup>;
- c tracked vehicles.

3 Type-approval or individual approval under this Directive is optional for the following vehicles:

- a vehicles designed and constructed for use principally on construction sites or in quarries, port or airport facilities;
- b vehicles designed and constructed for use by the armed services, civil defence, fire services and forces responsible for maintaining public order; and
- c mobile machinery,

to the extent that these vehicles fulfil the requirements of this Directive. Such optional approvals shall be without prejudice to the application of Directive 2006/42/EC of the European Parliament and of the Council of 17 May 2006 on machinery<sup>(12)</sup>.

4 An individual approval under this Directive is optional for the following vehicles:

- a vehicles intended exclusively for racing on roads;
- b prototypes of vehicles used on the road under the responsibility of a manufacturer to perform a specific test programme provided they have been specifically designed and constructed for this purpose.

## Article 3

### Definitions

For the purposes of this Directive and of the regulatory acts listed in Annex IV, save as otherwise provided therein:

1. 'regulatory act' means a separate directive or regulation or a UNECE Regulation annexed to the Revised 1958 Agreement;
2. 'separate directive or regulation' means a directive or regulation listed in Part I of Annex IV. This term includes also their implementing acts;
3. 'type-approval' means the procedure whereby a Member State certifies that a type of vehicle, system, component or separate technical unit satisfies the relevant administrative provisions and technical requirements;
4. 'national type-approval' means a type-approval procedure laid down by the national law of a Member State, the validity of such approval being restricted to the territory of that Member State;
5. 'EC type-approval' means the procedure whereby a Member State certifies that a type of vehicle, system, component or separate technical unit satisfies the relevant administrative provisions and technical requirements of this Directive and of the regulatory acts listed in Annex IV or XI;
6. 'individual approval' means the procedure whereby a Member State certifies that a particular vehicle, whether unique or not, satisfies the relevant administrative provisions and technical requirements;
7. 'multi-stage type-approval' means the procedure whereby one or more Member States certify that, depending on the state of completion, an incomplete or completed type of vehicle satisfies the relevant administrative provisions and technical requirements of this Directive;
8. 'step-by-step type-approval' means a vehicle approval procedure consisting in the step-by-step collection of the whole set of EC type-approval certificates for the systems, components and separate technical units relating to the vehicle, and which leads, at the final stage, to the approval of the whole vehicle;
9. 'single-step type-approval' means a procedure consisting in the approval of a vehicle as a whole by means of a single operation;
10. 'mixed type-approval' means a step-by-step type-approval procedure for which one or more system approvals are achieved during the final stage of the approval of the whole vehicle, without it being necessary to issue the EC type-approval certificates for those systems;
11. 'motor vehicle' means any power-driven vehicle which is moved by its own means, having at least four wheels, being complete, completed or incomplete, with a maximum design speed exceeding 25 km/h;
12. 'trailer' means any non-self-propelled vehicle on wheels which is designed and constructed to be towed by a motor vehicle;
13. 'vehicle' means any motor vehicle or its trailer as defined in points (11) and (12);
14. 'hybrid motor vehicle' means a vehicle with at least two different energy converters and two different energy storage systems (on-vehicle) for the purpose of vehicle propulsion;
15. 'hybrid electric vehicle' means a hybrid vehicle that, for the purpose of mechanical propulsion, draws energy from both of the following on-vehicle sources of stored energy/power:

---

*Status: EU Directives are being published on this site to aid cross referencing from UK legislation. After IP completion day (31 December 2020 11pm) no further amendments will be applied to this version.*

---

- a consumable fuel,
  - an electrical energy/power storage device (e.g. battery, capacitor, flywheel/generator, etc.);
16. ‘mobile machinery’ means any self-propelled vehicle which is designed and constructed specifically to perform work which, because of its construction characteristics, is not suitable for carrying passengers or for transporting goods. Machinery mounted on a motor vehicle chassis shall not be considered as mobile machinery;
  17. ‘type of vehicle’ means vehicles of a particular category which do not differ in at least the essential respects specified in Section B of Annex II. A type of vehicle may contain variants and versions as defined in Section B of Annex II;
  18. ‘base vehicle’ means any vehicle which is used at the initial stage of a multi-stage type-approval process;
  19. ‘incomplete vehicle’ means any vehicle which must undergo at least one further stage of completion in order to meet the relevant technical requirements of this Directive;
  20. ‘completed vehicle’ means a vehicle, resulting from the process of multi-stage type-approval, which meets the relevant technical requirements of this Directive;
  21. ‘complete vehicle’ means any vehicle which need not be completed in order to meet the relevant technical requirements of this Directive;
  22. ‘end-of-series vehicle’ means any vehicle that is part of a stock which cannot be registered or sold or entered into service owing to the entry into force of new technical requirements against which it has not been approved;
  23. ‘system’ means an assembly of devices combined to perform one or more specific functions in a vehicle and which is subject to the requirements of any of the regulatory acts;
  24. ‘component’ means a device subject to the requirements of a regulatory act and intended to be part of a vehicle, which may be type-approved independently of a vehicle where the regulatory act makes express provisions for so doing;
  25. ‘separate technical unit’ means a device subject to the requirements of a regulatory act and intended to be part of a vehicle, which may be type-approved separately, but only in relation to one or more specified types of vehicle where the regulatory act makes express provisions for so doing;
  26. ‘original parts or equipment’ means parts or equipment which are manufactured according to the specifications and production standards provided by the vehicle manufacturer for the production of parts or equipment for the assembly of the vehicle in question. This includes parts or equipment which are manufactured on the same production line as these parts or equipment. It is presumed unless the contrary is proven, that parts constitute original parts if the part manufacturer certifies that the parts match the quality of the components used for the assembly of the vehicle in question and have been manufactured according to the specifications and production standards of the vehicle manufacturer;
  27. ‘manufacturer’ means the person or body who is responsible to the approval authority for all aspects of the type-approval or authorisation process and for ensuring conformity of production. It is not essential that the person or body be directly involved



- in all stages of the construction of the vehicle, system, component or separate technical unit which is the subject of the approval process;
28. ‘manufacturer’s representative’ means any natural or legal person established in the Community who is duly appointed by the manufacturer to represent him before the approval authority and to act on his behalf in matters covered by this Directive, and where reference is made to the term ‘manufacturer’, it is to be understood as indicating either the manufacturer or his representative;
29. ‘approval authority’ means the authority of a Member State with competence for all aspects of the approval of a type of vehicle, system, component or separate technical unit or of the individual approval of a vehicle; for the authorisation process, for issuing and, if appropriate, withdrawing approval certificates; for acting as the contact point for the approval authorities of other Member States; for designating the technical services and for ensuring that the manufacturer meets his obligations regarding the conformity of production;
30. ‘competent authority’ in Article 42 means either the approval authority or a designated authority, or an accreditation body acting on their behalf;
31. ‘technical service’ means an organisation or body designated by the approval authority of a Member State as a testing laboratory to carry out tests, or as a conformity assessment body to carry out the initial assessment and other tests or inspections, on behalf of the approval authority, it being possible for the approval authority itself to carry out those functions;
32. ‘virtual testing method’ means computer simulations including calculations which demonstrate whether a vehicle, a system, a component or a separate technical unit fulfils the technical requirements of a regulatory act. For testing purposes, a virtual method does not require the use of a physical vehicle, system, component or separate technical unit;
33. ‘type-approval certificate’ means the document whereby the approval authority officially certifies that a type of vehicle, system, component or separate technical unit is approved;
34. ‘EC type-approval certificate’ means the certificate set out in Annex VI or in the corresponding annex to a separate directive or regulation, the communication form set out in the relevant Annex to one of the UNECE Regulations listed in Part I or Part II of Annex IV to this Directive, being deemed to be equivalent thereto;
35. ‘individual approval certificate’ means the document whereby the approval authority officially certifies that a particular vehicle is approved;
36. ‘certificate of conformity’ means the document set out in Annex IX, issued by the manufacturer and certifying that a vehicle belonging to the series of the type approved in accordance with this Directive complied with all regulatory acts at the time of its production;
37. ‘information document’ means the document set out in Annex I or Annex III, or in the corresponding Annex to a separate directive, or regulation, that prescribes the information to be supplied by an applicant, it being permissible to supply the information document in the form of an electronic file;

---

*Status: EU Directives are being published on this site to aid cross referencing from UK legislation. After IP completion day (31 December 2020 11pm) no further amendments will be applied to this version.*

---

38. ‘information folder’ means the complete folder, including the information document, file, data, drawings, photographs, and so on, supplied by the applicant, it being permissible to supply the information folder in the form of an electronic file;
39. ‘information package’ means the information folder accompanied by the test reports and all other documents added by the technical service or by the approval authority to the information folder in the course of carrying out their functions, it being permissible to supply the information package in the form of an electronic file;
40. ‘index to the information package’ means the document listing the contents of the information package, suitably numbered or otherwise marked so as to identify clearly all the pages, the format of that document being such as to present a record of the successive steps in the management of the EC type-approval, in particular the dates of the revisions and updating.

## CHAPTER II

### GENERAL OBLIGATIONS

#### *Article 4*

#### **Obligations of Member States**

1 Member States shall ensure that manufacturers applying for approval comply with their obligations under this Directive.

2 Member States shall approve only such vehicles, systems, components or separate technical units as satisfy the requirements of this Directive.

3 Member States shall register or permit the sale or entry into service only of such vehicles, components and separate technical units as satisfy the requirements of this Directive.

They shall not prohibit, restrict or impede the registration, sale, entry into service or circulation on the road of vehicles, components or separate technical units, on grounds related to aspects of their construction and functioning covered by this Directive, if they satisfy the requirements of the latter.

4 Member States shall establish or appoint the authorities competent in matters concerning approval, and notify to the Commission such establishment or appointment in accordance with Article 43.

The notification act of the approval authorities shall include the name, the address, including electronic address, and their area of responsibility.

#### *Article 5*

#### **Obligations of manufacturers**

1 The manufacturer is responsible to the approval authority for all aspects of the approval process and for ensuring conformity of production, whether or not the manufacturer is directly involved in all stages of the construction of a vehicle, system, component or separate technical unit.

2 In the case of multi-stage type-approval, each manufacturer is responsible for the approval and conformity of production of the systems, components or separate technical units added at the stage of vehicle completion handled by him.

The manufacturer who modifies components or systems already approved at earlier stages shall be responsible for the approval and conformity of production of those components and systems.

3 For the purposes of this Directive, a manufacturer established outside the Community shall appoint a representative established in the Community to represent him before the approval authority.

## CHAPTER III

### EC TYPE-APPROVAL PROCEDURES

#### *Article 6*

#### **Procedures to be followed for the EC type-approval of vehicles**

1 The manufacturer may choose one of the following procedures:

- a step-by-step type-approval;
- b single-step type-approval;
- c mixed type-approval.

2 An application for step-by-step type-approval shall consist of the information folder containing the information required under Annex III and shall be accompanied by the complete set of type-approval certificates required pursuant to each of the applicable regulatory acts listed in Annex IV or Annex XI. In the case of the type-approval of a system or separate technical unit, pursuant to the applicable regulatory acts, the approval authority shall have access to the related information package until such time as the approval is either issued or refused.

3 An application for single-step type-approval shall consist of the information folder containing the relevant information required under Annex I, in relation to the regulatory acts specified in Annex IV or Annex XI and, where applicable, in Part II of Annex III.

4 In the case of a mixed type-approval procedure, the approval authority may exempt a manufacturer from the obligation to produce one or more EC system type-approval certificates, provided that the information folder is supplemented by the particulars, specified in Annex I, required for the approval of those systems during the vehicle approval phase, in which case each of the EC type-approval certificates thus waived shall be replaced by a test report.

5 Without prejudice to paragraphs 2, 3 and 4, the following information shall be supplied for the purposes of multi-stage type-approval:

- a at the first stage, those parts of the information folder and the EC type-approval certificates required for a complete vehicle which are relevant to the state of completion of the base vehicle;
- b at the second and subsequent stages, those parts of the information folder and the EC type-approval certificates which are relevant to the current stage of construction, together with a copy of the EC type-approval certificate for the vehicle issued at the preceding stage of construction; in addition, the manufacturer shall supply full details of any changes or additions that he has made to the vehicle.

---

*Status: EU Directives are being published on this site to aid cross referencing from UK legislation. After IP completion day (31 December 2020 11pm) no further amendments will be applied to this version.*

---

The information specified in points (a) and (b) may be supplied in accordance with the mixed type-approval procedure set out in paragraph 4.

6 The manufacturer shall submit the application to the approval authority. Only one application may be submitted in respect of a particular type of vehicle and it may be submitted in only one Member State.

A separate application shall be submitted for each type to be approved.

7 The approval authority may, by reasoned request, call upon the manufacturer to supply any additional information needed to enable a decision to be taken on what tests are required or to facilitate the execution of those tests.

8 The manufacturer shall make available to the approval authority as many vehicles as are necessary to enable the type-approval procedure to be conducted satisfactorily.

#### *Article 7*

### **Procedure to be followed for the EC type-approval of systems, components or separate technical units**

1 The manufacturer shall submit the application to the approval authority. Only one application may be submitted in respect of a particular type of system, component or separate technical unit and it may be submitted in only one Member State. A separate application shall be submitted for each type to be approved.

2 The application shall be accompanied by the information folder, the content of which is specified in the separate directives or regulations.

3 The approval authority may, by reasoned request, call upon the manufacturer to supply any additional information needed to enable a decision to be taken on what tests are required or to facilitate the execution of those tests.

4 The manufacturer shall make available to the approval authority as many vehicles, components or separate technical units as are required under the relevant separate directives or regulations for the performance of the required tests.

## CHAPTER IV

### **CONDUCT OF EC TYPE-APPROVAL PROCEDURES**

#### *Article 8*

### **General provisions**

1 Member States may not grant any EC type-approval without first ensuring that the procedures referred to in Article 12 have been duly and satisfactorily implemented.

2 Member States shall grant EC type-approvals in accordance with Articles 9 and 10.

3 If a Member State finds that a type of vehicle, system, component or separate technical unit, albeit in conformity with the required provisions, presents a serious risk to road safety or seriously harms the environment or seriously harms public health, it may refuse to grant

EC type-approval. In this case, it shall immediately send the other Member States and the Commission a detailed file explaining the reasons for its decision and setting out the evidence for its findings.

4 EC type-approval certificates shall be numbered in accordance with the method set out in Annex VII.

5 The approval authority shall, within 20 working days, send to the approval authorities of the other Member States a copy of the EC vehicle type-approval certificate, together with the attachments, for each type of vehicle which it has approved. The hard copy may be replaced by an electronic file.

6 The approval authority shall inform without delay the approval authorities of the other Member States of its refusal or withdrawal of any vehicle approval, together with the reasons for its decision.

7 The approval authority shall send at three-monthly intervals to the approval authorities of the other Member States a list of the system, component or separate technical unit EC type-approvals it has granted, amended, refused to grant or withdrawn during the preceding period. That list shall contain the particulars specified in Annex XIV.

8 If so requested by another Member State, the Member State which has granted an EC type-approval shall, within 20 working days of receiving that request, send a copy of the EC type-approval certificate in question, together with the attachments. The hard copy may be replaced by an electronic file.

#### *Article 9*

### **Specific provisions concerning vehicles**

- 1 Member States shall grant an EC approval in respect of:
- a a type of vehicle which conforms to the particulars in the information folder and which meets the technical requirements specified by the relevant regulatory acts listed in Annex IV;
  - b a type of special-purpose vehicle which conforms to the particulars in the information folder and which meets the technical requirements specified by the relevant regulatory acts listed in Annex XI.

The procedures set out in Annex V shall apply.

2 Member States shall grant a multi-stage type-approval in respect of a type of incomplete or completed vehicle which conforms to the particulars in the information folder and which meets the technical requirements specified by the relevant regulatory acts listed in Annex IV or Annex XI, having regard to the state of completion of the vehicle.

The multi-stage type-approval shall apply also to complete vehicles converted or modified by another manufacturer.

The procedures set out in Annex XVII shall apply.

- 3 In respect of each type of vehicle, the approval authority shall:
- a complete all the relevant sections of the EC type-approval certificate, including the test results sheet appended thereto, in accordance with the model set out in Annex VIII;
  - b compile or verify the index to the information package;

---

*Status: EU Directives are being published on this site to aid cross referencing from UK legislation. After IP completion day (31 December 2020 11pm) no further amendments will be applied to this version.*

---

- c issue the completed certificate, together with its attachments, to the applicant without unjustified delay.

4 In the case of an EC type-approval in relation to which, in accordance with Articles 20 or 22 or Annex XI, restrictions have been imposed as to its validity, or certain provisions of the regulatory acts have been waived, the EC type-approval certificate shall specify those restrictions or waivers.

5 Where particulars in the information folder specify provisions for special purpose vehicles as indicated in Annex XI, the EC type-approval certificate shall specify those provisions.

6 Where the manufacturer chooses the mixed type-approval procedure, the approval authority shall complete, in Part III of the information document, the model for which is set out in Annex III, the references for the test reports, established by regulatory acts, for which no EC type-approval certificate is available.

7 Where the manufacturer chooses the single-step type-approval procedure, the approval authority shall establish the list of applicable regulatory acts, the template of which is shown in the Appendix to Annex VI, and append that list to the EC type-approval certificate.

#### *Article 10*

#### **Specific provisions concerning systems, components or separate technical units**

1 Member States shall grant an EC type-approval in respect of a system which conforms to the particulars in the information folder and which meets the technical requirements laid down in the relevant separate directive or regulation, as prescribed in Annex IV or Annex XI.

2 Member States shall grant a component or separate technical unit EC type-approval in respect of a component or separate technical unit which conforms to the particulars in the information folder and which meets the technical requirements laid down in the relevant separate directive or regulation, as prescribed in Annex IV.

3 Where components or separate technical units, whether or not intended for repair, servicing or maintenance, are also covered by a system type-approval with respect to a vehicle, no additional component or separate technical unit approval shall be required unless provided for under the relevant regulatory act.

4 Where a component or separate technical unit fulfils its function or offers a specific feature only in conjunction with other parts of the vehicle, thereby making it possible to verify compliance with the requirements only when the component or separate technical unit is operating in conjunction with those other vehicle parts, the scope of the EC type-approval of the component or the separate technical unit shall be restricted accordingly. In such cases, the EC type-approval certificate shall specify any restriction on its use and shall indicate the special conditions for its mounting. When such a component or separate technical unit is fitted by the vehicle manufacturer, compliance with any applicable restrictions on use or conditions for mounting shall be verified at the time when the vehicle is approved.

## Article 11

### Tests required for EC type-approval

1 Compliance with the technical prescriptions laid down in this Directive and in the regulatory acts listed in Annex IV shall be demonstrated by means of appropriate tests performed by designated technical services.

The test procedures, the specific equipment and tools necessary to perform those tests shall be described in each of the regulatory acts.

2 The required tests shall be performed on vehicles, components and separate technical units which are representative of the type to be approved.

However, the manufacturer may select, in agreement with the approval authority, a vehicle, a system, a component or a separate technical unit which, while not representative of the type to be approved, combines a number of the most unfavourable features with regard to the required level of performance. Virtual testing methods may be used to aid decision-making during the selection process.

3 As alternatives to the test procedures referred to in paragraph 1 and with the agreement of the approval authority, virtual testing methods may be used at the request of the manufacturer with respect to the regulatory acts listed in Annex XVI.

4 The general conditions which virtual testing methods must fulfil are set out in Appendix 1 to Annex XVI.

For each of the regulatory acts listed in Annex XVI, the specific testing conditions and the administrative provisions related thereto shall be laid down in Appendix 2 to that Annex.

5 The Commission shall establish the list of the regulatory acts for which virtual testing methods are permitted, the specific conditions and the administrative provisions related thereto. These measures, designed to amend non-essential elements of this Directive, inter alia by supplementing it, shall be established and updated in accordance with the regulatory procedure with scrutiny referred to in Article 40(2).

## Article 12

### Conformity of production arrangements

1 The Member State which grants an EC type-approval shall take the necessary measures in accordance with Annex X to verify, if need be in cooperation with the approval authorities of the other Member States, that adequate arrangements have been made to ensure that production vehicles, systems, components or separate technical units, as the case may be, conform to the approved type.

2 The Member State which has granted an EC type-approval shall take the necessary measures in accordance with Annex X in relation to that approval to verify, if need be in cooperation with the approval authorities of the other Member States, that the arrangements referred to in paragraph 1 continue to be adequate and that production vehicles, systems, components or separate technical units, as the case may be, continue to conform to the approved type.

---

*Status: EU Directives are being published on this site to aid cross referencing from UK legislation. After IP completion day (31 December 2020 11pm) no further amendments will be applied to this version.*

---

Verification to ensure that products conform to the approved type shall be limited to the procedures set out in Annex X and in those regulatory acts that contain specific requirements. To that end, the approval authority of the Member State which has granted the EC type-approval may carry out any of the checks or tests prescribed in any of the regulatory acts listed in Annex IV or Annex XI on samples taken in the premises of the manufacturer, including production facilities.

3 When a Member State which has granted an EC type-approval establishes that the arrangements referred to in paragraph 1 are not being applied, deviate significantly from the arrangements and control plans agreed, or have ceased to be applied, although production is not discontinued, that Member State shall take the necessary measures, including the withdrawal of the type-approval, to ensure that the conformity of production procedure is followed correctly.

## CHAPTER V

### AMENDMENTS TO EC TYPE-APPROVALS

#### *Article 13*

#### **General provisions**

1 The manufacturer shall inform without delay the Member State that granted the EC type-approval of any change in the particulars recorded in the information package. That Member State shall decide, in accordance with the rules laid down in this Chapter, which procedure is to be followed. Where necessary, the Member State may decide, in consultation with the manufacturer, that a new EC type-approval is to be granted.

2 An application for the amendment of an EC type-approval shall be submitted exclusively to the Member State that granted the original EC type-approval.

3 If the Member State finds that, for the purposes of making an amendment, fresh inspections or fresh tests are necessary, it shall inform the manufacturer accordingly. The procedures referred to in Articles 14 and 15 shall apply only after the requisite fresh inspections or fresh tests have been successfully carried out.

#### *Article 14*

#### **Specific provisions concerning vehicles**

1 If particulars recorded in the information package have changed, the amendment shall be designated a 'revision'.

In such cases, the approval authority shall issue the revised page of the information package as necessary, marking each revised pages to show clearly the nature of the change and the date of re-issue. A consolidated, updated version of the information package, accompanied by a detailed description of the changes, shall be deemed to meet this requirement.

2 The revision shall be designated an 'extension' if, in addition to the provisions of paragraph 1:

- a further inspections or fresh tests are required;



- b any information on the EC type-approval certificate, with the exception of its attachments, has changed;
- c new requirements under any of the regulatory acts applicable to the approved vehicle type enter into force.

In such cases, the approval authority shall issue a revised EC type-approval certificate denoted by an extension number, incremented in accordance with the number of successive extensions already granted.

The approval certificate shall show clearly the reason for the extension and the date of re-issue.

3 Whenever amended pages or a consolidated, updated version are issued, the index to the information package attached to the approval certificate shall be amended accordingly to show the date of the most recent extension or revision, or the date of the most recent consolidation of the updated version.

4 No amendment to the approval of a type of vehicle shall be required if the new requirements referred to in paragraph 2(c) are, from a technical point of view, irrelevant to that type of vehicle or concern categories of vehicle other than the category to which it belongs.

#### *Article 15*

##### **Specific provisions concerning systems, components or separate technical units**

1 If particulars recorded in the information package have changed, the amendment shall be designated a 'revision'.

In such cases, the approval authority shall issue the revised pages of the information package as necessary, marking each revised page to show clearly the nature of the change and the date of re-issue. A consolidated, updated version of the information package, accompanied by a detailed description of the changes, shall be deemed to meet this requirement.

2 The revision shall be designated an 'extension' if, in addition to the provisions of paragraph 1:

- a further inspections or fresh tests are required;
- b any information on the EC type-approval certificate, with the exception of its attachments, has changed;
- c new requirements under any of the regulatory acts applicable to the approved system, component or separate technical unit enter into force.

In such cases, the approval authority shall issue a revised EC type-approval certificate denoted by an extension number, incremented in accordance with the number of successive extensions already granted. In cases where the amendment is necessitated by the application of paragraph 2(c), the third section of the approval number shall be updated.

The approval certificate shall show clearly the reason for the extension and the date of re-issue.

3 Whenever amended pages or a consolidated, updated version are issued, the index to the information package attached to the approval certificate shall be amended accordingly to show the date of the most recent extension or revision, or the date of the most recent consolidation of the updated version.

---

*Status: EU Directives are being published on this site to aid cross referencing from UK legislation. After IP completion day (31 December 2020 11pm) no further amendments will be applied to this version.*

---

## Article 16

### Issue and notification of amendments

1 In the case of an extension, the approval authority shall update all relevant sections of the EC type-approval certificate, the attachments thereto, and the index to the information package. The updated certificate and its attachments shall be issued to the applicant without unjustified delay.

2 In the case of a revision, the revised documents or the consolidated, updated version, as appropriate, including the revised index to the information package, shall be issued by the approval authority to the applicant without unjustified delay.

3 The approval authority shall notify any amendment made to EC type-approvals to the approval authorities of the other Member States in accordance with the procedures referred to in Article 8.

## CHAPTER VI

### VALIDITY OF AN EC TYPE-APPROVAL OF VEHICLES

## Article 17

### Termination of validity

1 An EC type-approval of a vehicle shall cease to be valid in any of the following cases:

- a new requirements in any regulatory act applicable to the approved vehicle become mandatory for the registration, sale or entry into service of new vehicles, and it is not possible to update the approval accordingly;
- b production of the approved vehicle is definitively discontinued voluntarily;
- c the validity of the approval expires by virtue of a special restriction.

2 Where only one variant within a type or one version within a variant becomes invalid, the EC type-approval of the vehicle in question shall lose validity only in so far as the particular variant or version is concerned.

3 When production of a particular type of vehicle is definitively discontinued, the manufacturer shall notify the approval authority that granted the EC type-approval for that vehicle. Upon receiving such notification, that authority shall inform the approval authorities of the other Member States accordingly within 20 working days.

Article 27 shall apply only to discontinuation in the circumstances referred to in paragraph 1(a) of this Article.

4 Without prejudice to paragraph 3, in cases where an EC type-approval of a vehicle is due to become invalid, the manufacturer shall notify the approval authority that granted the EC type-approval.

The approval authority shall without unjustified delay communicate all relevant information to the approval authorities of the other Member States so as to enable the application, where appropriate, of Article 27. That communication shall specify,

in particular, the date of production and the vehicle identification number of the last vehicle produced.

## CHAPTER VII

### CERTIFICATE OF CONFORMITY AND MARKINGS

#### *Article 18*

#### **Certificate of conformity**

1 The manufacturer, in his capacity as the holder of an EC type-approval of a vehicle, shall deliver a certificate of conformity to accompany each vehicle, whether complete, incomplete or completed, that is manufactured in conformity with the approved vehicle type.

In the case of an incomplete or completed vehicle, the manufacturer shall complete only those items on side 2 of the certificate of conformity which have been added or changed at the current stage of approval and, if applicable, shall attach to the certificate all certificates of conformity delivered at the previous stage.

2 The certificate of conformity shall be drawn up in one of the official languages of the Community. Any Member State may request the certificate of conformity to be translated into its own language or languages.

3 The certificate of conformity shall be designed to prevent forgery. To that end, the paper used shall be protected either by coloured graphics or by a watermark in the form of the manufacturer's identification mark.

4 The certificate of conformity shall be completed in its entirety and shall not contain restrictions as regards the use of the vehicle other than those provided for in a regulatory act.

5 The certificate of conformity as set out in Part I of Annex IX for vehicles approved in accordance with the provisions of Article 20(2) shall display in the title thereof the phrase 'For complete/completed vehicles, type-approved in application of Article 20 (provisional approval).'

6 The certificate of conformity, as set out in Part I of Annex IX for vehicles type-approved in accordance with Article 22 shall display in the title thereof the phrase 'For complete/completed vehicles type-approved in small series', and in close proximity thereto the year of production followed by a sequential number, between 1 and the limit indicated in the table set out in Annex XII, denoting, in respect of each year of production, the position of that vehicle within the production allocated for that year.

7 Without prejudice to the provisions of paragraph 1, the manufacturer may transmit data or information contained in the certificate of conformity by electronic mean to the registration authority of the Member State.

8 A duplicate of the certificate of conformity may be issued only by the manufacturer. The word 'duplicate' must be clearly visible on the face of any duplicate certificate.

---

*Status: EU Directives are being published on this site to aid cross referencing from UK legislation. After IP completion day (31 December 2020 11pm) no further amendments will be applied to this version.*

---

### Article 19

#### EC type-approval mark

- 1 The manufacturer of a component or separate technical unit, whether or not it is part of a system, shall affix to each component or unit manufactured in conformity with the approved type the EC type-approval mark, required by the relevant separate directive or regulation.
- 2 Where no EC type-approval mark is required, the manufacturer shall affix at least his trade name or trade mark, and the type number and/or an identification number.
- 3 The EC type-approval mark shall be in accordance with the Appendix to Annex VII.

### CHAPTER VIII

#### NEW TECHNOLOGIES OR CONCEPTS INCOMPATIBLE WITH SEPARATE DIRECTIVES

### Article 20

#### Exemptions for new technologies or new concepts

- 1 Member States may, on application by the manufacturer, grant an EC type-approval in respect of a type of system, component or separate technical unit that incorporates technologies or concepts which are incompatible with one or more regulatory acts listed in Part I of Annex IV, subject to authorisation being granted by the Commission in accordance with the procedure referred to in Article 40(3).
- 2 Pending the decision as to whether or not authorisation is granted, the Member State may grant a provisional approval, valid only in its territory, in respect of a type of vehicle covered by the exemption sought, provided that it informs the Commission and the other Member States thereof without delay by means of a file containing the following elements:
  - a the reasons why the technologies or concepts in question make the system, component or separate technical unit incompatible with the requirements;
  - b a description of the safety and environmental considerations concerned and the measures taken;
  - c a description of the tests, including their results, demonstrating that, by comparison with the requirements from which exemption is sought, at least an equivalent level of safety and environmental protection is ensured.
- 3 Other Member States may decide to accept the provisional approval referred to in paragraph 2 on their territory.
- 4 The Commission shall decide, in accordance with the procedure referred to in Article 40(3), whether or not to allow the Member State to grant an EC type-approval in respect of that type of vehicle.

Where appropriate, the decision shall also specify whether its validity is subject to any restrictions, such as time-limits. In all cases, the validity of the approval shall not be less than 36 months.

If the Commission decides to refuse authorisation, the Member State shall immediately give notice to the holder of the provisional type-approval referred to in paragraph 2 of this Article that the provisional approval will be revoked six months after the date of the Commission's decision. However, vehicles manufactured in conformity with the provisional approval before it was revoked shall be permitted to be registered, sold or enter service in any Member State that accepted the provisional approval.

5 This Article does not apply where a system, component or separate technical unit complies with a UNECE Regulation to which the Community has acceded.

#### *Article 21*

#### **Action required**

1 Where the Commission finds that there are sound grounds for granting an exemption pursuant to Article 20, it shall immediately take the necessary steps to adapt the separate directives or regulations concerned to technological developments. These measures, designed to amend non-essential elements of the separate directives or regulations listed in Part I of Annex IV shall be adopted in accordance with the regulatory procedure with scrutiny referred to in Article 40(2).

Where the exemption pursuant to Article 20 relates to a UNECE Regulation, the Commission shall propose an amendment to the relevant UNECE Regulation in accordance with the procedure applicable under the Revised 1958 Agreement.

2 As soon as the relevant regulatory acts have been amended, any restriction attaching to the exemption shall be lifted immediately.

If the necessary steps to adapt the regulatory acts have not been taken, the validity of an exemption may be extended, at the request of the Member State which granted the approval, by another decision adopted in accordance with the procedure referred to in Article 40(3).

### CHAPTER IX

#### **VEHICLES PRODUCED IN SMALL SERIES**

#### *Article 22*

#### **EC type-approval of small series**

1 At the request of the manufacturer and within the quantitative limits set out in Section 1 of Part A of Annex XII, Member States shall grant, in accordance with the procedure referred to in Article 6(4), an EC type-approval in respect of a type of vehicle which satisfies at least the requirements listed in the Appendix to Part I of Annex IV.

2 Paragraph 1 shall not apply to special purpose vehicles.

3 EC type-approval certificates shall be numbered in accordance with Annex VII.

---

*Status: EU Directives are being published on this site to aid cross referencing from UK legislation. After IP completion day (31 December 2020 11pm) no further amendments will be applied to this version.*

---

### Article 23

#### National type-approval of small series

1 In the case of vehicles produced within the quantitative limits specified in Section 2 of Part A of Annex XII, Member States may waive one or more of the provisions of one or more of the regulatory acts listed in Annex IV or Annex XI, provided that they lay down relevant alternative requirements.

‘Alternative requirements’ means administrative provisions and technical requirements which aim to ensure a level of road safety and environmental protection which is equivalent to the greatest extent practicable to the level provided for by the provisions of Annex IV or Annex XI, as appropriate.

2 Member States may, in the case of the vehicles referred to in paragraph 1, waive one or more of the provisions of this Directive.

3 The provisions referred to in paragraphs 1 and 2 shall only be waived where a Member State has reasonable grounds for so doing.

4 For the purpose of type-approval of vehicles under this Article, Member States shall accept systems, components or separate technical units which are type-approved in accordance with the regulatory acts listed in Annex IV.

5 The type-approval certificate shall specify the nature of the waivers granted pursuant to paragraphs 1 and 2.

The type-approval certificate, the model for which is set out in Annex VI, shall not bear the heading ‘EC vehicle type-approval certificate’. However, type-approval certificates shall be numbered in accordance with Annex VII.

6 The validity of the type-approval shall be restricted to the territory of the Member State that granted the approval. However, if the manufacturer so requests, the approval authority shall send by registered mail or by electronic mail a copy of the type-approval certificate and its attachments to the approval authorities of the Member States designated by the manufacturer.

Within 60 days of receipt, such a Member State shall decide whether or not it accepts the type-approval. It shall formally communicate that decision to the approval authority referred to in the first subparagraph.

A Member State shall not refuse the type-approval unless it has reasonable grounds to believe that the technical provisions according to which the vehicle was approved are not equivalent to its own.

7 On request of an applicant who wishes to sell, register or put into service a vehicle in another Member State, the Member State that granted the approval shall provide the applicant with a copy of the type-approval certificate including the information package.

A Member State shall permit the sale, registration or entry into service of this vehicle unless it has reasonable grounds to believe that the technical provisions according to which the vehicle was approved are not equivalent to its own.

## CHAPTER X

**INDIVIDUAL APPROVALS***Article 24***Individual approvals**

1 Member States may exempt a particular vehicle, whether unique or not, from compliance with one or more of the provisions of this Directive or with one or more of the regulatory acts listed in Annex IV or Annex XI, provided that they impose alternative requirements.

The provisions referred to in subparagraph 1 shall only be waived where a Member State has reasonable grounds for so doing.

‘Alternative requirements’ means administrative provisions and technical requirements which aim to ensure a level of road safety and environmental protection, which is equivalent to the greatest extent practicable to the level provided for by the provisions of Annex IV or Annex XI, as appropriate.

2 Member States shall not carry out destructive tests. They shall use any relevant information provided by the applicant establishing compliance with the alternative requirements.

3 Member States shall accept any system, component or separate technical unit EC type-approval instead of the alternative requirements.

4 An application for individual approval shall be submitted by the manufacturer or by the owner of the vehicle or by a person acting on their behalf, provided the latter is established in the Community.

5 A Member State shall grant an individual approval if the vehicle conforms to the description appended to the application and satisfies the applicable technical requirements and shall without unjustified delay issue an individual approval certificate.

The format of the individual approval certificate shall be based on the template of the EC type-approval certificate set out in Annex VI and shall contain at least the information necessary to complete the application for registration provided for in Council Directive 1999/37/EC of 29 April 1999 on the registration documents for vehicles<sup>(13)</sup>. Individual approval certificates shall not bear the heading ‘EC vehicle approval’.

An individual approval certificate shall bear the vehicle identification number of the vehicle concerned.

6 The validity of an individual approval shall be restricted to the territory of the Member State that granted the approval.

Where an applicant wishes to sell, register or put into service in another Member State a vehicle which has been granted an individual approval, the Member State that granted the approval shall, on request, provide the applicant with a statement of the technical provisions against which the vehicle was approved.

With regard to a vehicle which has been granted an individual approval by a Member State in accordance with the provisions of this Article, another Member State shall permit that vehicle to be sold, registered or to enter into service unless it has reasonable

---

*Status: EU Directives are being published on this site to aid cross referencing from UK legislation. After IP completion day (31 December 2020 11pm) no further amendments will be applied to this version.*

---

grounds to believe that the technical provisions against which the vehicle was approved are not equivalent to its own.

7 At the request of the manufacturer or of the owner of the vehicle, Member States shall grant an individual approval to a vehicle which complies with the provisions of this Directive and with the regulatory acts listed in Annex IV or Annex XI, as appropriate.

In such a case, Member States shall accept the individual approval and shall permit the sale, registration and entry into service of the vehicle.

8 The provisions of this Article may apply to vehicles which have been type-approved in accordance with this Directive and which have been modified before their first registration or entry into service.

#### *Article 25*

### **Specific provisions**

1 The procedure set out in Article 24 may apply to a particular vehicle during the successive stages of its completion in accordance with a multi-stage type-approval procedure.

2 The procedure set out in Article 24 may not replace an intermediate stage within the normal sequence of a multi-stage type-approval procedure and may not apply for the purposes of obtaining the first-stage approval of a vehicle.

## CHAPTER XI

### **REGISTRATION, SALE AND ENTRY INTO SERVICE**

#### *Article 26*

### **Registration, sale and entry into service of vehicles**

1 Without prejudice to the provisions of Articles 29 and 30, Member States shall register, and permit the sale or entry into service of, vehicles only if they are accompanied by a valid certificate of conformity issued in accordance with Article 18.

In the case of incomplete vehicles, Member States shall permit the sale of such vehicles but may refuse their permanent registration and entry into service for such time as the vehicles remain incomplete.

2 Vehicles exempted from the requirement concerning a certificate of conformity may be registered, sold or put into service only if they satisfy the relevant technical requirements of this Directive.

3 As regards small-series vehicles, the number of vehicles registered, sold or entered into service in the course of a single year shall not exceed the number of units shown in Part A of Annex XII.



## Article 27

### **Registration, sale and entry into service of end-of-series vehicles**

1 Subject to the limits specified in Section B of Annex XII, and in respect only of a limited period of time, Member States may register and permit the sale or entry into service of vehicles conforming to a type of vehicle whose EC type-approval is no longer valid.

The first subparagraph shall apply only to vehicles within the territory of the Community which were covered by a valid EC type-approval at the time of their production, but which had not been registered or put into service before that EC type-approval lost its validity.

2 The option provided for in paragraph 1 shall be available, in the case of complete vehicles, for a period of twelve months from the date on which validity of the EC type-approval expired and, in the case of completed vehicles, for a period of eighteen months from that date.

3 A manufacturer who wishes to benefit from the provisions of paragraph 1 shall submit a request to the competent authority of each Member State concerned by the entry into service of the vehicles in question. The request must specify any technical or economic reasons preventing those vehicles from complying with the new technical requirements.

The Member States concerned shall decide, within three months of receiving such a request, whether and in what number to permit the registration of those vehicles within their territory.

4 Paragraphs 1, 2 and 3 shall apply *mutatis mutandis* to vehicles which were covered by a national type-approval but which had not been registered or put into service before that approval ceased to be valid, in application of Article 45, owing to the compulsory enforcement of the EC type-approval procedure.

5 Member States shall apply appropriate measures to ensure that the number of vehicles to be registered or put into service in the framework of the procedure set out in this Article is effectively monitored.

## Article 28

### **Sale and entry into service of components and separate technical units**

1 Member States shall permit the sale or entry into service of components or separate technical units if and only if they comply with the requirements of the relevant regulatory acts and are properly marked in accordance with Article 19.

2 Paragraph 1 shall not apply in the case of components or separate technical units which are specifically constructed or designed for new vehicles not covered by this Directive.

3 By way of derogation from paragraph 1, Member States may permit the sale and entry into service of components or separate technical units that have been exempted from one or more provisions of a regulatory act in application of Article 20 or are intended for mounting on vehicles covered by approvals granted under Articles 22, 23 or 24 that concern the component or separate technical unit in question.

4 By way of derogation from paragraph 1, and unless otherwise provided for in a regulatory act, Member States may permit the sale and entry into service of components or

---

*Status: EU Directives are being published on this site to aid cross referencing from UK legislation. After IP completion day (31 December 2020 11pm) no further amendments will be applied to this version.*

---

separate technical units that are intended for mounting on vehicles which, at the time of their entry into service, were not required, by this Directive or by Directive 70/156/EEC to be EC type-approved.

## CHAPTER XII

### SAFEGUARD CLAUSES

#### *Article 29*

#### **Vehicles, systems, components or separate technical units in compliance with this Directive**

1 If a Member State finds that new vehicles, systems, components or separate technical units, albeit in compliance with the applicable requirements or properly marked, present a serious risk to road safety, or seriously harm the environment or public health, that Member State may, for a maximum period of six months, refuse to register such vehicles or to permit the sale or entry into service in its territory of such vehicles, components or separate technical units.

In such cases, the Member State concerned shall immediately notify the manufacturer, the other Member States and the Commission accordingly, stating the reasons on which its decision is based and, in particular, whether it is the result of:

- shortcomings in the relevant regulatory acts, or
- incorrect application of the relevant requirements.

2 The Commission shall consult the parties concerned as soon as possible and, in particular, the approval authority that granted the type-approval in order to prepare the decision.

3 Where the measures referred to in paragraph 1 are attributed to shortcomings in the relevant regulatory acts, the appropriate measures shall be taken as follows:

- where separate directives or regulations listed in Part I of Annex IV are concerned, the Commission shall amend them in accordance with the regulatory procedure with scrutiny referred to in Article 40(2),
- where UNECE Regulations are concerned, the Commission shall propose the necessary draft amendments to the relevant UNECE Regulations in accordance with the procedure applicable under the Revised 1958 Agreement.

4 Where the measures referred to in paragraph 1 are attributed to incorrect application of the relevant requirements, the Commission shall take the appropriate measures to ensure compliance with such requirements.

#### *Article 30*

#### **Vehicles, systems, components or separate technical units not in conformity with the approved type**

1 If a Member State which has granted an EC type-approval finds that new vehicles, systems, components or separate technical units accompanied by a certificate of conformity or bearing an approval mark do not conform to the type it has approved, it shall take the necessary measures, including, where necessary, the withdrawal of type-approval, to ensure that production vehicles, systems, components or separate technical units, as the case may be, are

brought into conformity with the approved type. The approval authority of that Member State shall advise the approval authorities of the other Member States of the measures taken.

2 For the purposes of paragraph 1, deviations from the particulars in the EC type-approval certificate or the information package shall be deemed to constitute failure to conform to the approved type.

A vehicle shall not be deemed to deviate from the approved type where tolerances are permitted by the relevant regulatory acts and those tolerances are respected.

3 If a Member State demonstrates that new vehicles, components or separate technical units accompanied by a certificate of conformity or bearing an approval mark do not conform to the approved type, it may ask the Member State which granted the EC type-approval to verify that vehicles, systems, components or separate technical units in production continue to conform to the approved type. On receipt of such a request, the Member State concerned shall take the requisite action as soon as possible and in any case within six months of the date of the request.

4 The approval authority shall request the Member State which granted the system, component, separate technical unit or incomplete vehicle type-approval to take the necessary action to ensure that vehicles in production are brought back into conformity with the approved type in the following cases:

- a in relation to an EC vehicle type-approval, where the non-conformity of a vehicle is attributable exclusively to the non-conformity of a system, component or separate technical unit;
- b in relation to a multi-stage type-approval, where the non-conformity of a completed vehicle is attributable exclusively to the non-conformity of a system, component or separate technical unit being part of the incomplete vehicle, or of the incomplete vehicle itself.

On receipt of such a request, the Member State concerned shall take the requisite action, if necessary in conjunction with the Member State making the request, as soon as possible and in any case within six months of the date of the request. Where a failure to conform is established, the approval authority of the Member State which granted the system, component or separate technical unit EC type-approval or the approval of the incomplete vehicle shall take the measures set out in paragraph 1.

5 The approval authorities shall inform each other within 20 working days of any withdrawal of EC type-approval and of the reasons therefor.

6 If the Member State that granted EC type-approval disputes the failure to conform notified to it, the Member States concerned shall endeavour to settle the dispute. The Commission shall be kept informed and, where necessary, shall hold appropriate consultations with a view to reaching a settlement.

### *Article 31*

#### **Sale and entry into service of parts or equipment which are capable of posing a significant risk to the correct functioning of essential systems**

1 Member States shall permit the sale, the offer for sale or entry into service of parts or equipment which are capable of posing a significant risk to the correct functioning of systems that are essential for the safety of the vehicle or for its environmental performance, only if those parts or equipment have been authorised by an approval authority in accordance with paragraphs 5 to 10.

---

*Status: EU Directives are being published on this site to aid cross referencing from UK legislation. After IP completion day (31 December 2020 11pm) no further amendments will be applied to this version.*

---

2 Parts or equipment subject to authorisation in accordance with paragraph 1 shall be inserted in the list to be established in Annex XIII. Such a decision shall be preceded by an evaluation resulting in a report and strive for a fair balance between the following elements:

- a the existence of a serious risk to the safety or environmental performance of vehicles fitted with the parts or equipment under consideration; and
- b the effect on consumers and manufacturers in the after-market of the imposition under this Article of a possible authorisation requirement on the parts or equipment under consideration.

3 Paragraph 1 shall not apply to original parts or equipment which are covered by a system type-approval with respect to a vehicle and to parts or equipment which are type-approved in accordance with the provisions of one of the regulatory acts listed in Annex IV, except where those approvals relate to aspects other than those covered in paragraph 1. Paragraph 1 shall not apply to parts or equipment exclusively produced for racing vehicles not intended for use on public roads. If parts or equipment included in Annex XIII have a dual use for racing and on the road, these parts or equipment may not be sold or offered for sale to the general public for use in on-road vehicles unless they comply with the requirements of this Article.

Where appropriate, the Commission shall adopt provisions for identifying the parts or equipment referred to in this paragraph.

4 The Commission shall, after consulting stakeholders, establish the procedure and the requirements of the authorisation process referred to in paragraph 1, and adopt the provisions for the subsequent updating of the list established in Annex XIII. Those requirements shall include prescriptions for safety, environmental protection and, where needed, for testing standards. They may be based on the regulatory acts listed in Annex IV, may be developed according to the relevant state of safety, environmental and testing technology, or, if this is an appropriate way of achieving the required safety or environmental objectives, may consist of a comparison of the part or equipment with the environmental or safety performance of the original vehicle, or of any of its parts, as appropriate.

5 For the purposes of paragraph 1, the manufacturer of parts or equipment shall submit to the approval authority a test report drafted by a designated technical service which certifies that the parts or equipment for which authorisation is sought comply with the requirements referred to in paragraph 4. The manufacturer may introduce only one application per type per part with only one approval authority.

The application shall include details concerning the manufacturer of the parts or equipment, the type, identification and part numbers of the parts or equipment for which authorisation is sought, as well as the vehicle manufacturer's name, type of vehicle and, if appropriate, years of construction or any other information permitting the identification of the vehicle for which the fitting of such parts or equipment is intended.

When the approval authority is satisfied, taking account of the test report and other evidence, that the parts or equipment in question comply with the requirements referred to in paragraph 4, it shall issue a certificate to the manufacturer without unjustified delay. This certificate shall authorise the parts or equipment to be sold, offered for sale or fitted to vehicles in the Community subject to the second subparagraph of paragraph 9.

6 Each part or piece of equipment authorised in application of this Article shall be appropriately marked.

The Commission shall establish marking and packaging requirements, as well as the model and numbering system of the certificate referred to in paragraph 5.

7 The measures referred to in paragraphs 2 to 6 shall be adopted in accordance with the regulatory procedure with scrutiny referred to in Article 40(2) as they are designed to amend non-essential elements of this Directive, inter alia by supplementing it.

8 The manufacturer shall inform without delay the approval authority that issued the certificate of any change affecting the conditions under which it was delivered. That approval authority shall decide whether the certificate has to be reviewed or reissued and whether fresh tests are necessary.

The manufacturer shall be responsible for ensuring that the parts and equipment are produced and continue to be produced under the conditions under which the certificate was issued.

9 Before delivering any authorisation, the approval authority shall verify the existence of satisfactory arrangements and procedures for ensuring effective control of the conformity of production.

Where the approval authority finds that the conditions for issuing the authorisation are no longer fulfilled, it shall request the manufacturer to take the necessary measures to ensure that the parts or equipment are brought back into conformity. If necessary, it shall withdraw the authorisation.

10 Any disagreement between Member States in relation to the certificates referred to in paragraph 5 shall be brought to the attention of the Commission. It shall take appropriate measures, including, where necessary, requiring the withdrawal of the authorisation, after having consulted the Member States.

11 This Article shall not be applicable to a part or piece of equipment before it is listed in Annex XIII. For any entry or group of entries in Annex XIII a reasonable transitional period shall be fixed to allow the manufacturer of the part or equipment to apply for and obtain an authorisation. At the same time a date may be fixed, where appropriate, to exclude parts and equipment designed for vehicles type-approved before that date from the application of this Article.

12 As long as a decision as to whether or not a part or piece of equipment is to be included in the list referred to in paragraph 1 has not been taken, Member States may maintain national provisions dealing with parts or equipment which are capable of posing a significant risk to the correct functioning of systems that are essential for the safety of the vehicle or its environmental performance.

Once such a decision in this regard has been taken, the national provisions dealing with the parts or equipment in question shall cease to be valid.

13 As from 29 October 2007, Member States shall not adopt new provisions dealing with parts and equipment which can affect the correct functioning of systems that are essential for the safety of the vehicle or its environmental performance.

### *Article 32*

#### **Recall of vehicles**

1 Where a manufacturer who has been granted an EC vehicle type-approval is obliged, in application of the provisions of a regulatory act or of Directive 2001/95/EC, to recall vehicles already sold, registered or put into service because one or more systems, components or separate technical units fitted to the vehicle, whether or not duly approved in accordance with this

---

*Status: EU Directives are being published on this site to aid cross referencing from UK legislation. After IP completion day (31 December 2020 11pm) no further amendments will be applied to this version.*

---

Directive, presents a serious risk to road safety, public health or environmental protection, he shall immediately inform the approval authority that granted the vehicle approval thereof.

2 The manufacturer shall propose to the approval authority a set of appropriate remedies to neutralise the risk referred to in paragraph 1. The approval authority shall communicate the proposed measures to the authorities of the other Member States without delay.

The competent authorities shall ensure that the measures are effectively implemented in their respective territories.

3 If the measures are considered to be insufficient by the authorities concerned or have not been implemented quickly enough, they shall inform the approval authority that granted the EC vehicle type-approval without delay.

The approval authority shall then inform the manufacturer. If the approval authority which granted the EC type-approval is itself not satisfied with the measures of the manufacturer, it shall take all protective measures required, including the withdrawal of the EC vehicle type-approval where the manufacturer does not propose and implement effective corrective measures. In case of withdrawal of the EC vehicle type-approval, the concerned approval authority shall notify the manufacturer, the approval authorities of the other Member States and the Commission by registered letter or equivalent electronic means within 20 working days.

4 This Article shall also apply to parts that are not subject to any requirement under a regulatory act.

#### *Article 33*

### **Notification of decisions and remedies available**

All decisions taken pursuant to the provisions adopted in implementation of this Directive and all decisions refusing or withdrawing EC type-approval, or refusing registration or prohibiting sales, shall state in detail the reasons on which they are based.

Any such decision shall be notified to the party concerned who shall, at the same time, be informed of the remedies available to him under the laws in force in the Member State concerned and of the time limits allowed for the exercise of such remedies.

## CHAPTER XIII

### **INTERNATIONAL REGULATIONS**

#### *Article 34*

### **UNECE Regulations required for EC type-approval**

1 UNECE Regulations to which the Community has acceded and which are listed in Part I of Annex IV and in Annex XI are part of the EC type-approval of a vehicle in the same way as the separate directives or regulations. They shall apply to the categories of vehicles listed in the relevant columns in the table of Part I of Annex IV and Annex XI.

2 When the Community has decided to apply on a compulsory basis a UNECE Regulation for the purpose of EC vehicle type-approval in accordance with Article 4(4)

of Decision 97/836/EC, the annexes to this Directive shall be amended as appropriate in accordance with the regulatory procedure with scrutiny referred to in Article 40(2) of this Directive. The act amending the Annexes to this Directive shall also specify the dates of compulsory application of the UNECE Regulation or of its amendments. Member States shall repeal or adapt any national legislation that is incompatible with the UNECE Regulation in question.

Where such a UNECE Regulation replaces an existing separate directive or regulation, the relevant entry in Part I of Annex IV and in Annex XI shall be replaced by the number of the UNECE Regulation and the corresponding entry in Part II of Annex IV shall be deleted in accordance with the same procedure.

3 In the cases referred to in the second subparagraph of paragraph 2, the separate directive or regulation replaced by the UNECE Regulation shall be repealed in accordance with the regulatory procedure with scrutiny referred to in Article 40(2).

Where a separate directive is repealed, Member States shall repeal any national legislation that was adopted for the transposition of that directive.

4 Direct references may be made in this Directive or in the separate directives or regulations to international standards and regulations without reproducing them in the Community legal framework.

#### *Article 35*

### **Equivalence of UNECE Regulations with directives or regulations**

1 The UNECE Regulations listed in Part II of Annex IV are recognised as being equivalent to the corresponding separate directives or regulations in as much as they share the same scope and subject matter.

The approval authorities of the Member States shall accept approvals granted in accordance with those UNECE Regulations and, where applicable, the pertaining approval marks, in lieu of the corresponding approvals and approval marks granted in accordance with the equivalent separate directive or regulation.

2 Where the Community has decided to apply, for the purposes of paragraph 1, a new UNECE Regulation or a UNECE Regulation as amended, Part II of Annex IV shall be amended as appropriate. These measures, designed to amend non-essential elements of this Directive shall be adopted in accordance with the regulatory procedure with scrutiny referred to in Article 40(2).

#### *Article 36*

### **Equivalence with other regulations**

The Council may, acting by qualified majority on a proposal from the Commission, recognise the equivalence between the conditions or provisions for EC type-approval of systems, components and separate technical units established by this Directive and the procedures established by international regulations or regulations of third countries, in the framework of multilateral or bilateral agreements between the Community and third countries.

## CHAPTER XIV

### PROVISION OF TECHNICAL INFORMATION

#### *Article 37*

##### **Information intended for users**

1 The manufacturer may not supply any technical information related to the particulars provided for in this Directive or in the regulatory acts listed in Annex IV which diverges from the particulars approved by the approval authority.

2 Where a regulatory act makes specific provisions for so doing, the manufacturer shall make available to users all relevant information and necessary instructions describing any special conditions or restrictions attaching to the use of a vehicle, a component or a separate technical unit.

That information shall be supplied in the official languages of the Community. It shall be provided, in agreement with the approval authority, in an appropriate supporting document, such as the owner's manual or the maintenance book.

#### *Article 38*

##### **Information intended for manufacturers of components or separate technical units**

1 The vehicle manufacturer shall make available to the manufacturers of components or separate technical units all those particulars including, as the case may be, drawings specifically listed in the annex or appendix to a regulatory act that are necessary for EC type-approval of components or separate technical units, or necessary to obtain an authorisation under Article 31.

The vehicle manufacturer may impose a binding agreement on the manufacturers of components or separate technical units to protect the confidentiality of any information that is not in the public domain, including what is related to intellectual property rights.

2 The manufacturer of components or separate technical units, in his capacity as the holder of an EC type-approval certificate which, in accordance with Article 10(4), includes restrictions on use or special mounting conditions or both, shall provide all the detailed information thereon to the vehicle manufacturer.

Where a regulatory act makes provision for so doing, the manufacturer of components or separate technical units shall provide, together with the components or separate technical units produced, instructions regarding restrictions on use or special mounting conditions or both.



## CHAPTER XV

**IMPLEMENTATION MEASURES AND AMENDMENTS***Article 39***Implementation measures and amendments to this Directive and the separate directives and regulations**

1 The Commission shall adopt the measures necessary for the implementation of each separate directive or regulation in compliance with the rules laid down in each directive or regulation concerned.

2 The Commission shall adopt amendments to the annexes to this Directive or to the provisions of the separate directives or regulations listed in Part I of Annex IV, which are necessary to adapt them to the development of scientific and technical knowledge or to the specific needs of persons with disabilities.

3 The Commission shall adopt amendments to this Directive which are necessary to lay down technical requirements for small series vehicles, vehicles approved under the individual approval procedure and special purpose vehicles.

4 When the Commission becomes aware of serious risks to road users or to the environment, which require urgent measures, it may amend the provisions of the separate directives or regulations listed in Part I of Annex IV.

5 The Commission shall adopt amendments which are necessary in the interest of good administration and in particular those needed to ensure the coherence of the separate directives or regulations listed in Part I of Annex IV either amongst themselves or with other pieces of Community law.

6 When, in application of Decision 97/836/EC, new UNECE Regulations or amendments to existing UNECE Regulations to which the Community has acceded are adopted, the Commission shall amend the annexes to this Directive accordingly.

7 Each new separate directive or regulation shall introduce the appropriate amendments to the annexes to this Directive.

8 The annexes to this Directive may be amended by means of regulations.

9 Measures referred to in this Article shall be adopted in accordance with the regulatory procedure with scrutiny referred to in Article 40(2) as they are designed to amend non-essential elements of this Directive or of the separate directives and regulations, inter alia by supplementing them.

*Article 40***Committee**

1 The Commission shall be assisted by a committee referred to as the 'Technical Committee — Motor Vehicles' (TCMV).

2 Where reference is made to this paragraph, Article 5a(1) to (4), and Article 7 of Decision 1999/468/EC shall apply, having regard to the provisions of Article 8 thereof.

---

*Status: EU Directives are being published on this site to aid cross referencing from UK legislation. After IP completion day (31 December 2020 11pm) no further amendments will be applied to this version.*

---

3 Where reference is made to this paragraph, Articles 5 and 7 of Decision 1999/468/EC shall apply, having regard to the provisions of Article 8 thereof.

The period referred to in Article 5(6) of Decision 1999/468/EC shall be set at three months.

## CHAPTER XVI

### DESIGNATION AND NOTIFICATION OF TECHNICAL SERVICES

#### *Article 41*

#### **Designation of technical services**

1 When a Member State designates a technical service, the latter shall comply with the provisions of this Directive.

2 The technical services shall carry out themselves or supervise the tests required for approval or inspections specified in this Directive or in a regulatory act listed in Annex IV, except where alternative procedures are specifically permitted. They may not conduct tests or inspections for which they have not been duly designated.

3 The technical services shall fall into one or more of the four following categories of activities, depending on their field of competence:

- a category A, technical services which carry out in their own facilities the tests referred to in this Directive and in the regulatory acts listed in Annex IV;
- b category B, technical services which supervise the tests referred to in this Directive and in the regulatory acts listed in Annex IV, performed in the manufacturer's facilities or in the facilities of a third party;
- c category C, technical services which assess and monitor on a regular basis the manufacturer's procedures for controlling conformity of production;
- d category D, technical services which supervise or perform tests or inspections in the framework of the surveillance of conformity of production.

4 Technical services shall demonstrate appropriate skills, specific technical knowledge and proven experience in the specific fields covered by this Directive and the regulatory acts listed in Annex IV.

In addition, technical services shall comply with the standards listed in Appendix 1 to Annex V which are relevant for the activities they carry out. However, this requirement does not apply for the purposes of the last stage of a multi-stage type-approval procedure as referred to in Article 25(1).

5 An approval authority may act as a technical service for one or more of the activities referred to in paragraph 3.

6 A manufacturer or a subcontracting party acting on his behalf may be designated as a technical service for category A activities with regard to the regulatory acts listed in Annex XV.

The Commission shall amend the list of these regulatory acts where necessary in accordance with the regulatory procedure with scrutiny referred to in Article 40(2).

7 The entities referred to in paragraphs 5 and 6 shall comply with the provisions of this Article.

8 Technical services, other than those designated in accordance with paragraph 6, of a third country may be notified for the purposes of Article 43 only in the framework of a bilateral agreement between the Community and the third country in question.

#### *Article 42*

##### **Assessment of the skills of the technical services**

1 The skills referred to in Article 41 shall be demonstrated by an assessment report established by a competent authority. This may include a certificate of accreditation issued by an accreditation body.

2 The assessment on which the report referred to in paragraph 1 is based shall be conducted in accordance with the provisions of Appendix 2 to Annex V.

The assessment report shall be reviewed after a maximum period of three years.

3 The assessment report shall be communicated to the Commission upon request.

4 The approval authority which acts as a technical service shall demonstrate compliance through documentary evidence.

This includes an assessment conducted by auditors independent of the activity being assessed. Such auditors may be from within the same organisation provided that they are managed autonomously from personnel undertaking the assessed activity.

5 A manufacturer or a subcontracting party acting on his behalf, designated as a technical service, shall comply with the relevant provisions of this Article.

#### *Article 43*

##### **Procedures for notification**

1 Member States shall notify to the Commission the name, the address including electronic address, the responsible persons and the category of activities with respect to each designated technical service. They shall notify it of any subsequent modifications thereto.

The notification act shall state in respect of which regulatory acts the technical services have been designated.

2 A technical service may conduct the activities described in Article 41 for the purposes of type-approval only if it has been notified beforehand to the Commission.

3 The same technical service may be designated and notified by several Member States irrespective of the category of activities which it conducts.

4 Where a specific organisation or competent body, the activity of which is not included in those referred to in Article 41, needs to be designated in application of a regulatory act, the notification shall be made in accordance with the provisions of this Article.

5 The Commission shall publish a list and details regarding the approval authorities and technical services on its web-site.

---

*Status: EU Directives are being published on this site to aid cross referencing from UK legislation. After IP completion day (31 December 2020 11pm) no further amendments will be applied to this version.*

---

## CHAPTER XVII

### FINAL PROVISIONS

#### *Article 44*

##### **Transitional provisions**

1 Pending the necessary amendments to this Directive in order to include vehicles not yet covered or to complete the administrative and technical provisions regarding type-approval of vehicles other than M<sub>1</sub> produced in small series, and to lay down harmonised administrative and technical provisions regarding the individual approval procedure, and pending expiry of the transitional periods provided for in Article 45, Member States shall continue to grant national approvals for those vehicles, provided that such approvals are based on the harmonised technical requirements laid down in this Directive.

2 On application by the manufacturer or, in the case of individual approval, by the owner of the vehicle and on submission of the information required, the Member State concerned shall complete and issue the type-approval certificate or the individual approval certificate as appropriate. The certificate shall be issued to the applicant.

With respect to vehicles of the same type, other Member States shall accept a certified true copy as proof that the requisite tests have been carried out.

3 Where a particular vehicle covered by an individual approval has to be registered in another Member State, that Member State may require, from the approval authority that has issued the individual approval, any additional information stating in detail the nature of the technical requirements satisfied by that particular vehicle.

4 Pending the harmonisation of registration and taxation systems of the Member States in relation to vehicles covered by this Directive, Member States may use national codes in order to facilitate registration and taxation in their territory. For this purpose, Member States may subdivide the versions shown in Part II of Annex III, provided that the particulars used for the subdivision are expressly stated in the information package or can be derived from it by a simple calculation.

#### *Article 45*

##### **Application dates for EC type-approval**

1 As regards EC type-approval, Member States shall grant EC approval to new types of vehicle from the dates specified in Annex XIX.

2 On application by the manufacturer, Member States may grant EC approval to new types of vehicle from 29 April 2009.

3 Until the dates specified in the fourth column of the table set out in Annex XIX, Article 26(1) shall not apply to new vehicles for which a national approval has been granted before the dates specified in the third column thereof or for which there has been no approval.

4 At the request of the manufacturer, and until the dates specified in column 3 of rows 6 and 9 of the table set out in Annex XIX, Member States shall continue to grant national type-approvals as an alternative to EC vehicle type-approval for vehicles of category M<sub>2</sub> or M<sub>3</sub> on the condition that those vehicles and their systems, components and separate technical units

have been type-approved in accordance with the regulatory acts listed in Part I of Annex IV to this Directive.

5 This Directive shall not invalidate any EC type-approval granted to vehicles of category M<sub>1</sub> before 29 April 2009 nor prevent the extension of such approvals.

6 As regards the EC approval of new types of systems, components or separate technical units, Member States shall apply this Directive from 29 April 2009.

This Directive shall not invalidate any EC type-approval granted for systems, components or separate technical units before 29 April 2009 nor prevent the extension of such approvals.

#### *Article 46*

#### **Penalties**

Member States shall determine the penalties applicable for infringement of the provisions of this Directive, and in particular of the prohibitions contained in or resulting from Article 31, and of the regulatory acts listed in Part I of Annex IV and shall take all necessary measures for their implementation. The penalties determined shall be effective, proportionate and dissuasive. Member States shall notify these provisions to the Commission no later than 29 April 2009 and shall notify any subsequent modifications thereof as soon as possible.

#### *Article 47*

#### **Assessment**

1 No later than 29 April 2011, Member States shall inform the Commission of the application of the type-approval procedures laid down in this Directive and, in particular, of the application of the multi-stage process. Where appropriate, the Commission shall propose the amendments deemed necessary to improve the type-approval process.

2 On the basis of the information supplied under paragraph 1, the Commission shall report to the European Parliament and the Council on the application of this Directive no later than 29 October 2011. If appropriate, the Commission may propose the postponement of the application dates referred to in Article 45.

#### *Article 48*

#### **Transposition**

1 Member States shall adopt and publish, before 29 April 2009, the laws, regulations and administrative provisions necessary to comply with the substantive amendments of this Directive. They shall forthwith communicate to the Commission the text of those provisions.

They shall apply those provisions from 29 April 2009.

When Member States adopt those provisions, they shall contain a reference to this Directive or be accompanied by such a reference on the occasion of their official publication. They shall also include a statement that references in existing laws, regulations and administrative provisions to the Directive repealed by this Directive

---

*Status: EU Directives are being published on this site to aid cross referencing from UK legislation. After IP completion day (31 December 2020 11pm) no further amendments will be applied to this version.*

---

shall be construed as references to this Directive. Member States shall determine how such reference is to be made and how that statement is to be formulated.

2 Member States shall communicate to the Commission the text of the main provisions of national law which they adopt in the field covered by this Directive.

#### *Article 49*

#### **Repeal**

Directive 70/156/EEC is repealed with effect from 29 April 2009, without prejudice to the obligations of the Member States relating to the time-limits for transposition into national law and application of the directives set out in Part B of Annex XX.

References to the repealed Directive shall be construed as references to this Directive and shall be read in accordance with the correlation table set out in Annex XXI.

#### *Article 50*

#### **Entry into force**

This Directive shall enter into force on the 20th day following its publication in the *Official Journal of the European Union*.

#### *Article 51*

#### **Addressees**

This Directive is addressed to the Member States.

[<sup>F1</sup>ANNEX I[<sup>F2</sup>COMPLETE LIST OF INFORMATION FOR THE PURPOSE OF EC TYPE-APPROVAL OF VEHICLES, COMPONENTS OR SEPARATE TECHNICAL UNITS]<sup>(14)</sup>**Textual Amendments**

- F1** Substituted by [Commission Regulation \(EC\) No 1060/2008 of 7 October 2008 replacing Annexes I, III, IV, VI, VII, XI and XV to Directive 2007/46/EC of the European Parliament and of the Council establishing a framework for the approval of motor vehicles and their trailers, and of systems, components and separate technical units intended for such vehicles \(Framework Directive\) \(Text with EEA relevance\).](#)
- F2** Substituted by [Commission Regulation \(EU\) 2015/166 of 3 February 2015 supplementing and amending Regulation \(EC\) No 661/2009 of the European Parliament and of the Council as regards the inclusion of specific procedures, assessment methods and technical requirements, and amending Directive 2007/46/EC of the European Parliament and of the Council, and Commission Regulations \(EU\) No 1003/2010, \(EU\) No 109/2011 and \(EU\) No 458/2011 \(Text with EEA relevance\).](#)

All information documents in this directive and in separate directives or regulations shall consist only of extracts from, and adhere to the item numbering system of, this total list.

The following information shall be supplied in triplicate and include a list of contents. Any drawings shall be supplied in appropriate scale and in sufficient detail on size A4 or on a folder of A4 format. Photographs, if any, shall show sufficient detail.

If the systems, components or separate technical units referred to in this annex have electronic controls, information concerning their performance shall be supplied.

## 0. GENERAL

0.1. Make (trade name of manufacturer): ...

0.2. Type: ...

0.2.0.1. Chassis: ...

0.2.0.2. Bodywork/complete vehicle: ...

0.2.1. Commercial name(s) (if available): ...

[<sup>F2</sup>0.3. Means of identification of type, if marked on the vehicle/component/separate technical unit<sup>(19)(15)</sup>: ...]

0.3.0.1. Chassis: ...

0.3.0.2. Bodywork/complete vehicle: ...

0.3.1. Location of that marking: ...

0.3.1.1. Chassis: ...

0.3.1.2. Bodywork/complete vehicle: ...

0.4. Category of vehicle<sup>(16)</sup>: ...

0.4.1. Classification(s) according to the dangerous goods which the vehicle is intended to transport: ...

---

*Status: EU Directives are being published on this site to aid cross referencing from UK legislation. After IP completion day (31 December 2020 11pm) no further amendments will be applied to this version.*

---

[<sup>F3</sup>0.5. Company name and address of manufacturer: ...]

**Textual Amendments**

**F3** Substituted by [Commission Regulation \(EU\) No 1230/2012 of 12 December 2012 implementing Regulation \(EC\) No 661/2009 of the European Parliament and of the Council with regard to type-approval requirements for masses and dimensions of motor vehicles and their trailers and amending Directive 2007/46/EC of the European Parliament and of the Council \(Text with EEA relevance\).](#)

0.6. Location and method of attachment of statutory plates and location of vehicle identification number: ...

0.6.1. On the chassis: ...

0.6.2. On the bodywork: ...

0.7. (Not attributed)

0.8. Name(s) and address(es) of assembly plant(s): ...

0.9. Name and address of the manufacturer's representative (if any): ...

[<sup>F2</sup>1. GENERAL CONSTRUCTION CHARACTERISTICS

1.1. Photographs and/or drawings of a representative vehicle/component/separate technical unit<sup>(19)</sup>:]

1.2. Dimensional drawing of the whole vehicle: ...

1.3. Number of axles and wheels: ...

1.3.1. Number and position of axles with twin wheels: ...

1.3.2. Number and position of steered axles: ...

1.3.3. Powered axles (number, position, interconnection): ...

1.4. Chassis (if any) (overall drawing): ...

1.5. Material used for the side-members<sup>(17)</sup>: ...

1.6. Position and arrangement of the engine: ...

1.7. Driving cab (forward control or bonneted)<sup>(18)</sup>: ...

1.8. Hand of drive: left/right<sup>(19)</sup>.

1.8.1. Vehicle is equipped to be driven in right/left<sup>(19)</sup> hand traffic.

[<sup>F3</sup>1.9. Specify if the towing vehicle is intended to tow semi-trailers or other trailers and, if the trailer is a semi-, drawbar-, centre-axle- or rigid drawbar trailer: ...]

[<sup>F4</sup>1.10. Specify if the vehicle is specially designed for the controlled-temperature carriage of goods: ...]



### Textual Amendments

- F4** Inserted by [Commission Regulation \(EU\) No 1230/2012 of 12 December 2012 implementing Regulation \(EC\) No 661/2009 of the European Parliament and of the Council with regard to type-approval requirements for masses and dimensions of motor vehicles and their trailers and amending Directive 2007/46/EC of the European Parliament and of the Council \(Text with EEA relevance\).](#)

## [<sup>F3</sup>2. MASSES AND DIMENSIONS<sup>(20)(21)(22)</sup>

(in kg and mm) (Refer to drawing where applicable)]

- 2.1. Wheelbase(s) (fully loaded)<sup>(23)</sup>:
  - 2.1.1. Two-axle vehicles: ...
  - [<sup>F3</sup>2.1.2. Vehicles with three or more axles
    - 2.1.2.1. Axle spacing between consecutive axles going from the foremost to the rearmost axle: ...
    - 2.1.2.2. Total axle spacing: ...]
- 2.2. Fifth wheel
  - 2.2.1. In the case of semi-trailers
    - 2.2.1.1. Distance between the axis of the fifth wheel kingpin and the rearmost end of the semi-trailer: ...
    - 2.2.1.2. Maximum distance between the axis of the fifth wheel kingpin and any point on the front of the semi-trailer: ...
    - 2.2.1.3. Semi-trailer special wheelbase (as defined in Section 7.6.1.2 of Annex I to Directive 97/27/EC): ...
  - 2.2.2. In the case of semi-trailer towing vehicles
    - 2.2.2.1. Fifth wheel lead (maximum and minimum; indicate the permissible values in the case of an incomplete vehicle)<sup>(24)</sup>: ...
    - 2.2.2.2. Maximum height of the fifth wheel (standardised)<sup>(25)</sup>: ...
- 2.3. Axle track(s) and width(s)
  - 2.3.1. Track of each steered axle<sup>(26)</sup>: ...
  - 2.3.2. Track of all other axles<sup>(26)</sup>: ...
  - 2.3.3. Width of the widest rear axle: ...
  - 2.3.4. Width of the foremost axle (measured at the outermost part of the tyres excluding the bulging of the tyres close to the ground): ...
- 2.4. Range of vehicle dimensions (overall)
  - 2.4.1. For chassis without bodywork
    - 2.4.1.1. Length<sup>(27)</sup>: ...

---

*Status: EU Directives are being published on this site to aid cross referencing from UK legislation. After IP completion day (31 December 2020 11pm) no further amendments will be applied to this version.*

---

- 2.4.1.1.1. Maximum permissible length: ...
- 2.4.1.1.2. Minimum permissible length: ...
- 2.4.1.1.3. In the case of trailers, maximum permissible drawbar length<sup>(28)</sup>: ...
- 2.4.1.2. Width<sup>(29)</sup>: ...
  - 2.4.1.2.1. Maximum permissible width: ...
  - 2.4.1.2.2. Minimum permissible width: ...
- 2.4.1.3. Height (in running order)<sup>(30)</sup> (for suspensions adjustable for height, indicate normal running position): ...
- 2.4.1.4. Front overhang<sup>(31)</sup>: ...
  - 2.4.1.4.1. Approach angle<sup>(32)</sup>: ..... degrees.
- 2.4.1.5. Rear overhang<sup>(33)</sup>: ...
  - 2.4.1.5.1. Departure angle<sup>(34)</sup>: ..... degrees.
  - 2.4.1.5.2. Minimum and maximum permissible overhang of the coupling point<sup>(35)</sup>: ...
- 2.4.1.6. Ground clearance (as defined in point 4.5 of Section A of Annex II)
  - 2.4.1.6.1. Between the axles: ...
  - 2.4.1.6.2. Under the front axle(s): ...
  - 2.4.1.6.3. Under the rear axle(s): ...
- 2.4.1.7. Ramp angle<sup>(36)</sup>: ..... degrees.
- 2.4.1.8. Extreme permissible positions of the centre of gravity of the body and/or interior fittings and/or equipment and/or payload: ...
- 2.4.2. For chassis with bodywork
  - 2.4.2.1. Length<sup>(27)</sup>: ...
    - 2.4.2.1.1. Length of the loading area: ...
    - 2.4.2.1.2. In the case of trailers, maximum permissible drawbar length<sup>(28)</sup>: ...
  - 2.4.2.2. Width<sup>(29)</sup>: ...
    - 2.4.2.2.1. Thickness of the walls (in the case of vehicles designed for controlled-temperature carriage of goods): ...
  - 2.4.2.3. Height (in running order)<sup>(30)</sup> (for suspensions adjustable for height, indicate normal running position): ...
  - 2.4.2.4. Front overhang<sup>(31)</sup>: ...
    - 2.4.2.4.1. Approach angle<sup>(32)</sup>: ..... degrees.
  - 2.4.2.5. Rear overhang<sup>(33)</sup>: ...

- 2.4.2.5.1. Departure angle<sup>(34)</sup>: ..... degrees.
- 2.4.2.5.2. Minimum and maximum permissible overhang of the coupling point<sup>(35)</sup>: ...
- 2.4.2.6. Ground clearance (as defined in point 4.5 of Section A of Annex II)
  - 2.4.2.6.1. Between the axles: ...
  - 2.4.2.6.2. Under the front axle(s): ...
  - 2.4.2.6.3. Under the rear axle(s): ...
- 2.4.2.7. Ramp angle<sup>(36)</sup>: ..... degrees.
- 2.4.2.8. Extreme permissible positions of the centre of gravity of the payload (in the case of non-uniform load): ...
- 2.4.2.9. Position of centre of gravity of the vehicle (M<sub>2</sub> and M<sub>3</sub>) at its technically permissible maximum laden mass in the longitudinal, transverse and vertical directions: ...
- 2.4.3. For bodywork approved without chassis (vehicles M<sub>2</sub> and M<sub>3</sub>)
  - 2.4.3.1. Length<sup>(27)</sup>: ...
  - 2.4.3.2. Width<sup>(29)</sup>: ...
  - 2.4.3.3. Nominal height (in running order)<sup>(30)</sup> on intended chassis type(s) (for suspensions adjustable for height, indicate normal running position): ...
- [<sup>F3</sup>2.5. **Minimum mass on the steering axle(s) for incomplete vehicles:**  
...]
- [<sup>F3</sup>2.6. **Mass in running order<sup>(37)</sup>**
  - (a) minimum and maximum for each variant: ...
  - (b) mass of each version (a matrix must be provided): ...
- 2.6.1. Distribution of this mass among the axles and, in the case of a semi-trailer, a centre-axle trailer or a rigid drawbar trailer, the mass on the coupling point: ...
  - (a) minimum and maximum for each variant: ...
  - (b) mass of each version (a matrix must be provided): ...]
- [<sup>F4</sup>2.6.2. Mass of the optional equipment (see the definition set out in point (5) of Article 2 of Commission Regulation (EU) No 1230/2012<sup>(38)</sup>): ...]
- 2.7. **Minimum mass of the completed vehicle** as stated by the manufacturer, in the case of an incomplete vehicle: ...
  - 2.7.1. Distribution of this mass among the axles and, in the case of a semi-trailer or centre-axle trailer, load on the coupling point: ...
- 2.8. **Technically permissible maximum laden mass** stated by the manufacturer<sup>(39)(40)</sup>: ...
  - 2.8.1. Distribution of this mass among the axles and, in the case of a semi-trailer or centre-axle trailer, load on the coupling point<sup>(40)</sup>: ...

---

*Status: EU Directives are being published on this site to aid cross referencing from UK legislation. After IP completion day (31 December 2020 11pm) no further amendments will be applied to this version.*

---

- 2.9. **Technically permissible maximum mass on each axle:** ...
- [<sup>F3</sup>2.10. **Technically permissible mass on each group of axles:** ...]
- [<sup>F3</sup>2.11. **Technically permissible maximum towable mass of the towing vehicle**  
in case of:]
- 2.11.1. Drawbar trailer: ...
- 2.11.2. Semi-trailer: ...
- 2.11.3. Centre-axle trailer: ...
- 2.11.3.1. Maximum ratio of the coupling overhang<sup>(41)</sup> to the wheel base: ...
- 2.11.3.2. Maximum V-value: ..... kN.
- [<sup>F3</sup>2.11.4. Rigid drawbar trailer: ...]
- [<sup>F3</sup>2.11.5. Technically permissible maximum laden mass of the combination<sup>(40)</sup>: ...]
- 2.11.6. Maximum mass of unbraked trailer: ...
- [<sup>F3</sup>2.12. **Technically permissible maximum mass at the coupling point:**
- 2.12.1. Of a towing vehicle: ...
- 2.12.2. Of a semi-trailer, a centre-axle trailer or a rigid drawbar trailer: ...]
- 2.12.3. Maximum permissible mass of the coupling device (if not fitted by the manufacturer):  
...
- 2.13. **Rear swing-out** (Section 7.6.2. and 7.6.3. of Annex I to Directive 97/27/EC): ...
- 2.14. **Engine power/maximum mass ratio:** ..... kW/kg.
- 2.14.1. Engine power/technically permissible maximum laden mass of the combination ratio  
(Section 7.10 of Annex I to Directive 97/27/EC): ..... kW/kg.
- 2.15. **Hill-starting ability** (solo vehicle)<sup>(42)</sup>: ..... %.
- [<sup>F3</sup>2.16. **Registration/in service maximum permissible masses** (optional)
- 2.16.1. Registration/in service maximum permissible laden mass: ...
- 2.16.2. Registration/in service maximum permissible mass on each axle and, in the case of  
a semi-trailer or centre-axle trailer, intended load on the coupling point stated by the  
manufacturer if lower than the technically permissible maximum mass on the coupling  
point: ...
- 2.16.3. Registration/in service maximum permissible mass on each group of axles: ...
- 2.16.4. Registration/in service maximum permissible towable mass: ...
- 2.16.5. Registration/in service maximum permissible mass of the combination: ...]

[<sup>F5</sup>2.17. Vehicle submitted to multi-stage type-approval (only in the case of incomplete or completed vehicles of category N<sub>1</sub> within the scope of Regulation (EC) No 715/2007: yes/no<sup>(19)</sup>

2.17.1. Mass of the base vehicle in running order: ... kg.

2.17.2. Default added mass, calculated in accordance with Section 5 of Annex XII to Regulation (EC) No 692/2008: ... kg.]

---

**Textual Amendments**

**F5** Inserted by [Commission Regulation \(EU\) No 143/2013 of 19 February 2013 amending Directive 2007/46/EC of the European Parliament and of the Council and Commission Regulation \(EC\) No 692/2008 as regards the determination of CO<sub>2</sub> emissions from vehicles submitted to multi-stage type-approval \(Text with EEA relevance\).](#)

3. POWER PLANT<sup>(43)</sup>

3.1. Manufacturer of the engine: ...

3.1.1. Manufacturer's engine code (as marked on the engine or other means of identification):  
...

3.1.2. Approval number (if appropriate) including fuel identification marking: ...

(heavy-duty vehicles only)

3.2. Internal combustion engine

3.2.1. Specific engine information

[<sup>F6</sup>3.2.1.1. Working principle: positive ignition/compression ignition/dual-fuel<sup>(19)</sup>

Cycle: four stroke/two stroke/rotary]<sup>(19)</sup>

---

**Textual Amendments**

**F6** Substituted by [Commission Regulation \(EU\) No 133/2014 of 31 January 2014 amending, for the purposes of adapting to technical progress as regards emission limits, Directive 2007/46/EC of the European Parliament and of the Council, Regulation \(EC\) No 595/2009 of the European Parliament and of the Council and Commission Regulation \(EU\) No 582/2011 \(Text with EEA relevance\).](#)

[<sup>F7</sup>3.2.1.1. Type of dual-fuel engine: Type 1A/Type 1B/Type 2A/Type 2B/Type 3B<sup>(19)(44)</sup>

---

**Textual Amendments**

**F7** Inserted by [Commission Regulation \(EU\) No 133/2014 of 31 January 2014 amending, for the purposes of adapting to technical progress as regards emission limits, Directive 2007/46/EC of the European Parliament and of the Council, Regulation \(EC\) No 595/2009 of the European Parliament and of the Council and Commission Regulation \(EU\) No 582/2011 \(Text with EEA relevance\).](#)

3.2.1.1.2. Gas energy ratio over the hot part of the WHTC test-cycle: ... %]

---

*Status: EU Directives are being published on this site to aid cross referencing from UK legislation. After IP completion day (31 December 2020 11pm) no further amendments will be applied to this version.*

---

- 3.2.1.2. Number and arrangement of cylinders: ...
- 3.2.1.2.1. Bore<sup>(45)</sup>: ..... mm
- 3.2.1.2.2. Stroke<sup>(45)</sup>: ..... mm
- 3.2.1.2.3. Firing order: ...
- 3.2.1.3. Engine capacity<sup>(46)</sup>: ..... cm<sup>3</sup>
- 3.2.1.4. Volumetric compression ratio<sup>(47)</sup>: ...
- 3.2.1.5. Drawings of combustion chamber, piston crown and, in the case of positive ignition engines, piston rings: ...
- 3.2.1.6. Normal engine idling speed<sup>(47)</sup>: ..... min<sup>-1</sup>
- 3.2.1.6.1. High engine idling speed<sup>(47)</sup>: ..... min<sup>-1</sup>
- [<sup>F7</sup>3.2.1.6.2. Idle on diesel: yes/no]<sup>(19)(44)</sup>
- 3.2.1.7. Carbon monoxide content by volume in the exhaust gas with the engine idling<sup>(47)</sup>: ..... % as stated by the manufacturer (positive ignition engines only)
- 3.2.1.8. Maximum net power<sup>(48)</sup>: ... kW at ... min<sup>-1</sup> (manufacturer's declared value)
- 3.2.1.9. Maximum permitted engine speed as prescribed by the manufacturer: ... min<sup>-1</sup>
- 3.2.1.10. Maximum net torque<sup>(48)</sup>: ... Nm at ... min<sup>-1</sup> (manufacturer's declared value)
- [<sup>F8</sup>3.2.1.11 (Euro VI only) Manufacturer references of the Documentation package required by Articles 5, 7 and 9 of Regulation (EU) No 582/2011 enabling the approval authority to evaluate the emission control strategies and the Systems on-board the engine to ensure the correct operation of NO<sub>x</sub> control measures]

#### Textual Amendments

**F8** Inserted by [Commission Regulation \(EU\) No 582/2011 of 25 May 2011 implementing and amending Regulation \(EC\) No 595/2009 of the European Parliament and of the Council with respect to emissions from heavy duty vehicles \(Euro VI\) and amending Annexes I and III to Directive 2007/46/EC of the European Parliament and of the Council \(Text with EEA relevance\).](#)

- 3.2.2. Fuel
- [<sup>F6</sup>3.2.2.1 Light-duty vehicles: Diesel/Petrol/LPG/NG or Biomethane/Ethanol (E 85)/Biodiesel/Hydrogen/H<sub>2</sub>NG<sup>(19)(49)</sup>
- 3.2.2.2. Heavy duty vehicles Diesel/Petrol/LPG/NG-H/NG-L/NG-HL/Ethanol (ED95)/Ethanol (E85)/LNG/LNG<sub>20</sub>/I<sup>(19)(49)</sup>
- [<sup>F8</sup>3.2.2.2 (Euro VI only) Fuels compatible with use by the engine declared by the manufacturer in accordance with Section 1.1.2 of Annex I to Regulation (EU) No 582/2011 (as applicable)]
- 3.2.2.3. Fuel tank inlet: restricted orifice/label<sup>(19)</sup>

- 3.2.2.4. Vehicle fuel type: Mono fuel, Bi fuel, Flex fuel<sup>(19)</sup>
- 3.2.2.5. Maximum amount of biofuel acceptable in fuel (manufacturer's declared value): ... % by volume
- 3.2.3. Fuel tank(s)
  - 3.2.3.1. Service fuel tank(s)
    - 3.2.3.1.1. Number and capacity of each tank: ...
    - 3.2.3.1.1. Material: ...
    - 3.2.3.1.2. Drawing and technical description of the tank(s) with all connections and all lines of the breathing and venting system, locks, valves, fastening devices: ...
    - 3.2.3.1.3. Drawing clearly showing the position of the tank(s) in the vehicle: ...
  - 3.2.3.2. Reserve fuel tank(s)
    - 3.2.3.2.1. Number and capacity of each tank: ...
    - 3.2.3.2.1. Material: ...
    - 3.2.3.2.2. Drawing and technical description of the tank(s) with all connections and all lines of the breathing and venting system, locks, valves, fastening devices: ...
    - 3.2.3.2.3. Drawing clearly showing the position of the tank(s) in the vehicle: ...
- 3.2.4. Fuel feed
  - 3.2.4.1. By carburettor(s): yes/no<sup>(19)</sup>
  - [<sup>F63</sup>3.2.4.2. By fuel injection (compression ignition or dual-fuel only): yes/no]<sup>(19)</sup>
    - 3.2.4.2.1. System description: ...
    - 3.2.4.2.2. Working principle: direct injection/pre-chamber/swirl chamber<sup>(19)</sup>
    - 3.2.4.2.3. Injection pump
      - 3.2.4.2.3. Make(s): ...
      - 3.2.4.2.3. Type(s): ...
      - 3.2.4.2.3. Maximum fuel delivery<sup>(19)(47)</sup>: ..... mm<sup>3</sup> /stroke or cycle at an engine speed of: ... min<sup>-1</sup> or, alternatively, a characteristic diagram: ...

(When boost control is supplied, state the characteristic fuel delivery and boost pressure versus engine speed)

  - 3.2.4.2.3.4. Static injection timing<sup>(47)</sup>: ...
  - 3.2.4.2.3.5. Injection advance curve<sup>(47)</sup>: ...
  - 3.2.4.2.3.6. Calibration procedure: test bench/engine<sup>(19)</sup>
  - 3.2.4.2.4. Governor
    - 3.2.4.2.4. Type: ...

---

*Status: EU Directives are being published on this site to aid cross referencing from UK legislation. After IP completion day (31 December 2020 11pm) no further amendments will be applied to this version.*

---

#### 3.2.4.2.4.4. Cut-off point

3.2.4.2.4.4.1. Speed at which cut-off starts under load: ..... min<sup>-1</sup>

3.2.4.2.4.4.2. Maximum no-load speed: ..... min<sup>-1</sup>

3.2.4.2.4.4.3. Idling speed: ..... min<sup>-1</sup>

#### 3.2.4.2.5. Injection piping (heavy-duty vehicles only)

3.2.4.2.5. Length: ..... mm

3.2.4.2.5. Internal diameter: ..... mm

3.2.4.2.5. Common rail, make and type: ...

#### 3.2.4.2.6. Injector(s)

3.2.4.2.6. Make(s): ...

3.2.4.2.6. Type(s): ...

3.2.4.2.6. Opening pressure<sup>(47)</sup>: ... kPa or characteristic diagram<sup>(47)</sup>: ...

#### 3.2.4.2.7. Cold start system

3.2.4.2.7. Make(s): ...

3.2.4.2.7. Type(s): ...

3.2.4.2.7. Description: ...

#### 3.2.4.2.8. Auxiliary starting aid

3.2.4.2.8. Make(s): ...

3.2.4.2.8. Type(s): ...

3.2.4.2.8. System description: ...

#### 3.2.4.2.9. Electronic controlled injection: yes/no<sup>(19)</sup>

3.2.4.2.9. Make(s): ...

3.2.4.2.9. Type(s):

3.2.4.2.9. Description of the system (in the case of systems other than continuous injection give equivalent details): ...

3.2.4.2.9. Make and type of the control unit (ECU): ...

3.2.4.2.9. Make and type of the fuel regulator: ...

3.2.4.2.9. Make and type of the air-flow sensor: ...

3.2.4.2.9. Make and type of fuel distributor: ...

3.2.4.2.9. Make and type of the throttle housing: ...

3.2.4.2.9. Make and type of water temperature sensor: ...



- 3.2.4.2.9. Make and type of air temperature sensor: ...
- 3.2.4.2.9. Make and type of air pressure sensor: ...
- 3.2.4.2.9. Software calibration number(s): ...
- 3.2.4.3. By fuel injection (positive ignition only): yes/no<sup>(19)</sup>
  - 3.2.4.3.1. Working principle: intake manifold (single-/multi-point/direct injection<sup>(19)</sup> /other (specify): ...
  - 3.2.4.3.2. Make(s): ...
  - 3.2.4.3.3. Type(s): ...
  - 3.2.4.3.4. System description (In the case of systems other than continuous injection give equivalent details): ...
  - 3.2.4.3.4. Make and type of the control unit (ECU): ...
  - 3.2.4.3.4. Make and type of fuel regulator: ...
  - 3.2.4.3.4. Make and type of air-flow sensor: ...
  - 3.2.4.3.4. Make and type of fuel distributor: ...
  - 3.2.4.3.4. Make and type of pressure regulator: ...
  - 3.2.4.3.4. Make and type of micro switch: ...
  - 3.2.4.3.4. Make and type of idling adjustment screw: ...
  - 3.2.4.3.4. Make and type of throttle housing: ...
  - 3.2.4.3.4. Make and type of water temperature sensor: ...
  - 3.2.4.3.4. Make and type of air temperature sensor: ...
  - 3.2.4.3.4. Make and type of air pressure sensor: ...
  - 3.2.4.3.4. Software calibration number(s): ...
- 3.2.4.3.5. Injectors: opening pressure<sup>(47)</sup>: ..... kPa or characteristic diagram: ...
  - 3.2.4.3.5. Make: ...
  - 3.2.4.3.5. Type: ...
- 3.2.4.3.6. Injection timing: ...
- 3.2.4.3.7. Cold start system
  - 3.2.4.3.7. Operating principle(s): ...
  - 3.2.4.3.7. Operating limits/settings<sup>(19)(47)</sup>: ...
- 3.2.4.4. Feed pump
  - 3.2.4.4.1. Pressure<sup>(47)</sup>: ... kPa or characteristic diagram<sup>(47)</sup>: ...
- 3.2.5. Electrical system

---

*Status: EU Directives are being published on this site to aid cross referencing from UK legislation. After IP completion day (31 December 2020 11pm) no further amendments will be applied to this version.*

---

- 3.2.5.1. Rated voltage: ..... V, positive/negative ground<sup>(19)</sup>
- 3.2.5.2. Generator
  - 3.2.5.2.1. Type: ...
  - 3.2.5.2.2. Nominal output: ..... VA
- 3.2.6. Ignition system (spark ignition engines only)
  - 3.2.6.1. Make(s): ...
  - 3.2.6.2. Type(s): ...
  - 3.2.6.3. Working principle: ...
  - 3.2.6.4. Ignition advance curve or map<sup>(47)</sup>: ...
  - 3.2.6.5. Static ignition timing<sup>(47)</sup>: ..... degrees before TDC
  - 3.2.6.6. Spark plugs
    - 3.2.6.6.1. Make: ...
    - 3.2.6.6.2. Type: ...
    - 3.2.6.6.3. Gap setting: ..... mm
  - 3.2.6.7. Ignition coil(s)
    - 3.2.6.7.1. Make: ...
    - 3.2.6.7.2. Type: ...
- 3.2.7. Cooling system: liquid/air<sup>(19)</sup>
  - 3.2.7.1. Nominal setting of the engine temperature control mechanism: ...
  - 3.2.7.2. Liquid
    - 3.2.7.2.1. Nature of liquid: ...
    - 3.2.7.2.2. Circulating pump(s): yes/no<sup>(19)</sup>
    - 3.2.7.2.3. Characteristics: ..... or
    - 3.2.7.2.3. Make(s): ...
    - 3.2.7.2.3. Type(s): ...
    - 3.2.7.2.4. Drive ratio(s): ...
    - 3.2.7.2.5. Description of the fan and its drive mechanism: ...
  - 3.2.7.3. Air
    - 3.2.7.3.1. Fan: yes/no<sup>(19)</sup>
    - 3.2.7.3.2. Characteristics: ..... or
    - 3.2.7.3.2. Make(s): ...

3.2.7.3.2.Type(s): ...

3.2.7.3.3.Drive ratio(s): ...

3.2.8. Intake system

3.2.8.1. Pressure charger: yes/no<sup>(19)</sup>

3.2.8.1.1.Make(s): ...

3.2.8.1.2.Type(s): ...

3.2.8.1.3.Description of the system (e.g. maximum charge pressure: ..... kPa; wastegate if applicable): ...

3.2.8.2. Intercooler: yes/no<sup>(19)</sup>

3.2.8.2.1.Type: air-air/air-water<sup>(19)</sup>

3.2.8.3. Intake depression at rated engine speed and at 100 % load (compression ignition engines only)

3.2.8.3.1.Minimum allowable: ..... kPa

3.2.8.3.2.Maximum allowable: ..... kPa

[<sup>F83</sup>3.2.8.3(Euro VI only) Actual Intake system depression at rated engine speed and at 100 % load on the vehicle: kPa]

3.2.8.4. Description and drawings of inlet pipes and their accessories (plenum chamber, heating device, additional air intakes, etc.): ...

3.2.8.4.1.Intake manifold description (include drawings and/or photos): ...

3.2.8.4.2.Air filter, drawings: ... or

3.2.8.4.2.Make(s): ...

3.2.8.4.2.Type(s): ...

3.2.8.4.3.Intake silencer, drawings: ... or

3.2.8.4.3.Make(s): ...

3.2.8.4.3.Type(s): ...

3.2.9. Exhaust system

3.2.9.1. Description and/or drawing of the exhaust manifold: ...

3.2.9.2. Description and/or drawing of the exhaust system: ...

[<sup>F63</sup>3.2.9.2(Euro VI only) Description and/or drawing of the elements of the exhaust system that are part of the engine system]

3.2.9.3. Maximum allowable exhaust back pressure at rated engine speed and at 100 % load (compression ignition engines only): ..... kPa

[<sup>F83</sup>3.2.9.3(Euro VI only) Actual exhaust back pressure at rated engine speed and at 100 % load on the vehicle (compression-ignition engines only): ... kPa]

---

*Status: EU Directives are being published on this site to aid cross referencing from UK legislation. After IP completion day (31 December 2020 11pm) no further amendments will be applied to this version.*

---

3.2.9.4. Type, marking of exhaust silencer(s): ...

Where relevant for exterior noise, reducing measures in the engine compartment and on the engine: ...

3.2.9.5. Location of the exhaust outlet: ...

3.2.9.6. Exhaust silencer containing fibrous materials: ...

[<sup>F6</sup>3.2.9.7 Complete exhaust system volume: ... dm<sup>3</sup>

3.2.9.7.1. (Euro VI only) Acceptable exhaust system volume: ... dm<sup>3</sup>

[<sup>F7</sup>3.2.9.7 (EURO VI only) Volume of the exhaust system that is part of the engine system: ... dm<sup>3</sup>

3.2.10. *Minimum cross-sectional areas of inlet and outlet ports: ...*

3.2.11. Valve timing or equivalent data

3.2.11.1. Maximum lift of valves, angles of opening and closing, or timing details of alternative distribution systems, in relation to dead centres. For variable timing system, minimum and maximum timing: ...

3.2.11.2. Reference and/or setting ranges<sup>(19)</sup>: ...

3.2.12. Measures taken against air pollution

3.2.12.1. Device for recycling crankcase gases (description and drawings): ...

[<sup>F8</sup>3.2.12. (Euro VI only) Device for recycling crankcase gases: yes/no (<sup>2</sup>)

If yes, description and drawings:

If no, compliance with Annex V to Regulation (EU) No 582/2011 required]

3.2.12.2. Additional pollution control devices (if any, and if not covered by another heading)

3.2.12.2.1. Catalytic converter: yes/no<sup>(19)</sup>

3.2.12.2.1.1. Number of catalytic converters and elements (provide the information below for each separate unit): ...

3.2.12.2.1.2. Dimensions, shape and volume of the catalytic converter(s): ...

3.2.12.2.1.3. Type of catalytic action: ...

3.2.12.2.1.4. Total charge of precious metals: ...

3.2.12.2.1.5. Relative concentration: ...

3.2.12.2.1.6. Substrate (structure and material): ...

3.2.12.2.1.7. Cell density: ...

3.2.12.2.1.8. Type of casing for the catalytic converter(s): ...

3.2.12.2.1.9. Location of the catalytic converter(s) (place and reference distance in the exhaust line):

...

- 3.2.12.2.1 Heat shield: yes/no<sup>(19)</sup>
- 3.2.12.2.2 Regeneration systems/method of exhaust after-treatment systems, description: ...
- 3.2.12.2.3 Number of Type I operating cycles (or equivalent engine bench cycles) between two cycles where regenerative phases occur under the conditions equivalent to Type I test (Distance 'D' in Figure 1 in Annex 13 to UNECE Regulation No 83): ...
- 3.2.12.2.4 Description of method employed to determine the number of cycles between two cycles where regenerative phases occur: ...
- 3.2.12.2.5 Parameters to determine the level of loading required before regeneration occurs (i.e. temperature, pressure etc.): ...
- 3.2.12.2.6 Description of method used to load system in the test procedure described in paragraph 3.1 of Annex 13 to UNECE Regulation No 83): ...
- 3.2.12.2.7 Normal operating temperature range: ..... K
- 3.2.12.2.8 Consumable reagents: yes/no<sup>(19)</sup>
- 3.2.12.2.9 Type and concentration of reagent needed for catalytic action: ...
- 3.2.12.2.10 Normal operational temperature range of reagent: ..... K
- 3.2.12.2.11 International standard: ...
- 3.2.12.2.12 Frequency of reagent refill: continuous/maintenance<sup>(19)</sup>
- 3.2.12.2.13 Make of catalytic converter: ...
- 3.2.12.2.14 Identifying part number: ...
- 3.2.12.2.15 Oxygen sensor: yes/no<sup>(19)</sup>
- 3.2.12.2.16 Make: ...
- 3.2.12.2.17 Location: ...
- 3.2.12.2.18 Control range: ...
- 3.2.12.2.19 Type: ...
- 3.2.12.2.20 Identifying part number: ...
- 3.2.12.2.21 Air injection: yes/no<sup>(19)</sup>
- 3.2.12.2.22 Type (pulse air, air pump, etc.): ...
- 3.2.12.2.23 Exhaust gas recirculation (EGR): yes/no<sup>(19)</sup>
- 3.2.12.2.24 Characteristics (make, type, flow, etc.): ...
- 3.2.12.2.25 Water-cooled system: yes/no<sup>(19)</sup>
- 3.2.12.2.26 Evaporative emissions control system: yes/no<sup>(19)</sup>
- 3.2.12.2.27 Detailed description of the devices and their state of tune: ...
- 3.2.12.2.28 Drawing of the evaporative control system: ...

---

*Status: EU Directives are being published on this site to aid cross referencing from UK legislation. After IP completion day (31 December 2020 11pm) no further amendments will be applied to this version.*

---

- 3.2.12.2.5 Drawing of the carbon canister: ...
- 3.2.12.2.5 Mass of dry charcoal: ..... g
- 3.2.12.2.5 Schematic drawing of the fuel tank with indication of capacity and material: ...
- 3.2.12.2.5 Drawing of the heat shield between tank and exhaust system: ...
- 3.2.12.2.6 Particulate trap (PT): yes/no<sup>(19)</sup>
- 3.2.12.2.6 Dimensions, shape and capacity of the particulate trap: ...
- 3.2.12.2.6 Design of the particulate trap: ...
- 3.2.12.2.6 Location (reference distance in the exhaust line): ...
- 3.2.12.2.6 Method or system of regeneration, description and/or drawing: ...
- 3.2.12.2.6 Number of Type I operating cycles (or equivalent engine bench cycles) between two cycles where regenerative phases occur under the conditions equivalent to Type I test (Distance 'D' in Figure 1 in Annex 13 to UNECE Regulation No 83): ...
- 3.2.12.2.6 Description of method employed to determine the number of cycles between two cycles where regenerative phases occur: ...
- 3.2.12.2.6 Parameters to determine the level of loading required before regeneration occurs (i.e. temperature, pressure etc.): ...
- 3.2.12.2.6 Description of method used to load system in the test procedure described in paragraph 3.1 of Annex 13 to UNECE Regulation No 83): ...
- 3.2.12.2.6 Make of particulate trap: ...
- 3.2.12.2.6 Identifying part number: ...
- 3.2.12.2.6 Normal operating temperature: ... (K) and pressure range ... (KPa)  
(heavy-duty vehicles only)
- 3.2.12.2.6 In the case of periodic regeneration (heavy-duty vehicles only)
- 3.2.12.2.6 Number of ETC test cycles between 2 regenerations (n1): ...<sup>[F8]</sup> (not applicable to Euro VI)
- <sup>[F8]</sup> 3.2.12.2.6 Euro VI only) Number of WHTC test cycles without regeneration (n):]
- 3.2.12.2.6 Number of ETC cycles during regeneration (n2): ...<sup>[F8]</sup> (not applicable to Euro VI)]
- <sup>[F8]</sup> 3.2.12.2.6 Euro VI only) Number of WHTC test cycles with regeneration (n<sub>R</sub>):]
- <sup>[F8]</sup> 3.2.12.2.6 Other systems: yes/no <sup>(1)</sup>
- 3.2.12.2.6 Description and operation]
- 3.2.12.2.7 On-board-diagnostic (OBD) system: yes/no<sup>(19)</sup>: ...
- <sup>[F8]</sup> 3.2.12.2.7 Euro VI only) Number of OBD engine families within the engine family
- 3.2.12.2.7 List of the OBD engine families (when applicable)

- 3.2.12.2.7.0.1 Number of the OBD engine family the parent engine / the engine member belongs to:
  - 3.2.12.2.7.0.2 Manufacturer references of the OBD-Documentation required by Article 5(4)(c) and Article 9(4) of Regulation (EU) No 582/2011 and specified in Annex X to that Regulation for the purpose of approving the OBD system
  - 3.2.12.2.7.0.3 When appropriate, manufacturer reference of the Documentation for installing in a vehicle an OBD equipped engine system
  - 3.2.12.2.7.0.4 When appropriate, manufacturer reference of the documentation package related to the installation on the vehicle of the OBD system of an approved engine]
- F9 3.2.12.2.7.0.7. . . . . .

**Textual Amendments**

**F9** Deleted by [Commission Regulation \(EU\) No 133/2014 of 31 January 2014 amending, for the purposes of adapting to technical progress as regards emission limits, Directive 2007/46/EC of the European Parliament and of the Council, Regulation \(EC\) No 595/2009 of the European Parliament and of the Council and Commission Regulation \(EU\) No 582/2011 \(Text with EEA relevance\).](#)

- F9 3.2.12.2.7.0.8. . . . . .
- 3.2.12.2.7.0.9 Written description and/or drawing of the MI: ...
  - 3.2.12.2.7.0.10 List and purpose of all components monitored by the OBD system: ...
  - 3.2.12.2.7.0.11 Written description (general working principles) for
    - 3.2.12.2.7.0.11.1 Positive-ignition engines
    - 3.2.12.2.7.0.11.2 Catalyst monitoring: ...
    - 3.2.12.2.7.0.11.3 Misfire detection: ...
    - 3.2.12.2.7.0.11.4 Oxygen sensor monitoring: ...
    - 3.2.12.2.7.0.11.5 Other components monitored by the OBD system: ...
    - 3.2.12.2.7.0.11.6 Compression-ignition engines: ...
    - 3.2.12.2.7.0.11.7 Catalyst monitoring: ...
    - 3.2.12.2.7.0.11.8 Particulate trap monitoring: ...
    - 3.2.12.2.7.0.11.9 Electronic fuelling system monitoring: ...
    - 3.2.12.2.7.0.11.10 NO<sub>x</sub> system monitoring: ...
    - 3.2.12.2.7.0.11.11 Other components monitored by the OBD system: ...
    - 3.2.12.2.7.0.11.12 Criteria for MI activation (fixed number of driving cycles or statistical method): ...
    - 3.2.12.2.7.0.11.13 List of all OBD output codes and formats used (with explanation of each): ...
    - 3.2.12.2.7.0.11.14 The following additional information shall be provided by the vehicle manufacturer for the purposes of enabling the manufacture of OBD-compatible replacement or service parts and diagnostic tools and test equipment.

*Status: EU Directives are being published on this site to aid cross referencing from UK legislation. After IP completion day (31 December 2020 11pm) no further amendments will be applied to this version.*

3.2.12.2.7.6.1 description of the type and number of the preconditioning cycles used for the original type approval of the vehicle.

3.2.12.2.7.6.2 description of the type of the OBD demonstration cycle used for the original type-approval of the vehicle for the component monitored by the OBD system.

3.2.12.2.7.6.3 comprehensive document describing all sensed components with the strategy for fault detection and MI activation (fixed number of driving cycles or statistical method), including a list of relevant secondary sensed parameters for each component monitored by the OBD system. A list of all OBD output codes and format used (with an explanation of each) associated with individual emission related power-train components and individual non-emission related components, where monitoring of the component is used to determine MI activation, including in particular a comprehensive explanation for the data given in service \$05 Test ID \$21 to FF and the data given in service \$06.

In the case of vehicle types that use a communication link in accordance with ISO 15765-4 ‘Road vehicles, diagnostics on controller area network (CAN) — Part 4: requirements for emissions-related systems’, a comprehensive explanation for the data given in service \$06 Test ID \$00 to FF, for each OBD monitor ID supported, shall be provided.

3.2.12.2.7.6.4 The information required above may be defined by completing a table as described below.

#### 3.2.12.2.7.6.4.1 Light-duty vehicles

Component	Fault code	Monitoring strategy	Fault detection criteria	MI activation criteria	Secondary parameters	Preconditioning	Demonstration test
Catalyst	P0420	Oxygen sensor 1 and sensor 2 signals	Difference between sensor 1 and sensor 2 signals-	3rd cycle	Engine speed load, A/F mode, catalyst temperature	Two type I cycles	Type I

#### 3.2.12.2.7.6.4.2 Heavy-duty vehicles

Component	Fault code	Monitoring strategy	Fault detection criteria	MI activation criteria	Secondary parameters	preconditioning	Demonstration test
SCR Catalyst	Pxxx	NO <sub>x</sub> sensor 1 and sensor 2 signals	Difference between sensor 1 and sensor 2 signals-	3rd cycle	Engine speed load, catalyst temperature reagent activity	Three OBD test cycles (3 short ESC cycles)	OBD test cycle (short ESC cycle)

[<sup>F8</sup>3.2.12.2.7.6.3 only) OBD Communication protocol standard:](<sup>50</sup>)



3.2.12.2.7 (Euro VI only) Manufacturer reference of the OBD related information required by of Article 5(4)(d) and Article 9(4) of Regulation (EU) No 582/2011 for the purpose of complying with the provisions on access to vehicle OBD and vehicle Repair and Maintenance Information, or

3.2.12.2.7A1 an alternative to a manufacturer reference provided in Section 3.2.12.2.7.7 reference of the attachment to the information document set out in Appendix 4 of Annex I to Regulation (EU) No 582/2011 that contains the following table, once completed according to the given example:

Component — Fault code — Monitoring strategy — Fault detection criteria — MI activation criteria — Secondary parameters — Preconditioning — Demonstration test  
Catalyst – P0420 — Oxygen sensor 1 and 2 signals — Difference between sensor 1 and sensor 2 signals — 3rd cycle — Engine speed, engine load, A/F mode, catalyst temperature — Two Type 1 cycles — Type 1]

[F7] 3.2.12.2.7A2 (Euro VI only) OBD components on-board the vehicle

3.2.12.2.7A3 Alternative approval as provided for in point 2.4.1 of Annex X to Regulation (EU) No 582/2011: yes/no<sup>(19)</sup>

3.2.12.2.7A4 List of OBD components on-board the vehicle

3.2.12.2.7A5 Written description and/or drawing of the MI<sup>(51)</sup>

3.2.12.2.7A6 Written description and/or drawing of the OBD off-board communication interface<sup>(51)</sup>

3.2.12.2.8 Other system (description and operation): ...

[F8] 3.2.12.2.8.1 (Euro VI only) Systems to ensure the correct operation of NO<sub>x</sub> control measures

[F6] 3.2.12.2.8.1.1 Driver inducement system]

[F7] 3.2.12.2.8.1.2 (Euro VI only) Engine with permanent deactivation of the driver inducement, for use by the rescue services or in vehicles specified in point (b) of Article 2(3) of this Directive: yes/no<sup>(1)</sup>

3.2.12.2.8.2 Activation of the creep mode

‘disable after restart’/‘disable after fuelling’/‘disable after parking’<sup>(19)(50)</sup>

3.2.12.2.8.3 (Euro VI only) Number of OBD engine families within the engine family considered when ensuring the correct operation of NO<sub>x</sub> control measures

[F7] 3.2.12.2.8.3.1 (Euro VI only) List of the OBD engine families within the engine family considered when ensuring the correct operation of NO<sub>x</sub> control measures (when applicable)

3.2.12.2.8.4 (Euro VI only) Number of the OBD engine family the parent engine/the engine member belongs to]

[F9] 3.2.12.2.8.4.1 . . . . .

3.2.12.2.8.5 (Euro VI only) Number of the OBD engine family the parent engine / the engine member belongs to

3.2.12.2.8.6 (Euro VI only) Lowest concentration of the active ingredient present in the reagent that does not activate the warning system (CD<sub>min</sub>): (% vol.)

---

*Status: EU Directives are being published on this site to aid cross referencing from UK legislation. After IP completion day (31 December 2020 11pm) no further amendments will be applied to this version.*

---

3.2.12.2.8 (Euro VI only) When appropriate, manufacturer reference of the Documentation for installing in a vehicle the systems to ensure the correct operation of NO<sub>x</sub> control measures

[<sup>F63</sup>3.2.12.2.8 (EURO VI only) Components on-board the vehicle of the systems ensuring the correct operation of NO<sub>x</sub> control measures

3.2.12.2.8.1 List of components on-board the vehicle of the systems ensuring the correct operation of NO<sub>x</sub> control measures]

3.2.12.2.8.2 When appropriate, manufacturer reference of the documentation package related to the installation on the vehicle of the system ensuring the correct operation of NO<sub>x</sub> control measures of an approved engine

3.2.12.2.8.3 Written description and/or drawing of the warning signal]<sup>(51)</sup>

3.2.12.2.8.4 Alternative approval provided for in point 2.1 of Annex XIII to Regulation (EU) No 582/2011: yes/no<sup>(19)</sup>

3.2.12.2.8.5 Heated/non-heated reagent tank and dosing system (see paragraph 2.4 of Annex 11 to UNECE Regulation No 49)]

3.2.12.2.9 Torque limiter: yes/no<sup>(19)</sup>

3.2.12.2.9.1 Description of the torque limiter activation (heavy-duty vehicles only): ...

3.2.12.2.9.2 Description of the full load curve limitation (heavy-duty vehicles only): ...

3.2.13. Smoke opacity

3.2.13.1. Location of the absorption coefficient symbol (compression ignition engines only): ...

3.2.13.2. Power at six points of measurement (see point 2.1 of Annex III to Directive 72/306/EEC as amended)

3.2.13.3. Engine power measured on test bench/on the vehicle<sup>(19)</sup>

3.2.13.3.1 Declared speeds and powers

Measurement points	Engine speed (min <sup>-1</sup> )	Power (kW)
1.....		
2.....		
3.....		
4.....		
5.....		
6.....		

3.2.14. Details of any devices designed to influence fuel economy (if not covered by other items): ...

3.2.15. LPG fuelling system: yes/no<sup>(19)</sup>

- 3.2.15.1. Type-approval number according to Directive 70/221/EEC (when the Directive will be amended to cover tanks for gaseous fuels) or approval number according to UNECE Regulation No 67 (OJ L 76, 6.4.1970, p. 34): ...
- 3.2.15.2. Electronic engine management control unit for LPG fuelling
  - 3.2.15.2.1 Make(s): ...
  - 3.2.15.2.2 Type(s): ...
  - 3.2.15.2.3 Emission-related adjustment possibilities: ...
- 3.2.15.3. Further documentation
  - 3.2.15.3.1 Description of the safeguarding of the catalyst at switch-over from petrol to LPG or back: ...
  - 3.2.15.3.2 System lay-out (electrical connections, vacuum connections compensation hoses, etc.): ...
  - 3.2.15.3.3 Drawing of the symbol: ...
- 3.2.16. NG fuelling system: yes/no<sup>(19)</sup>
  - 3.2.16.1. Type-approval number according to Directive 70/221/EEC (when the Directive will be amended to cover tanks for gaseous fuels) or approval number according to UNECE Regulation No 110 (OJ L 72, 14.3.2008, p. 113): ...
  - 3.2.16.2. Electronic engine management control unit for NG fuelling
    - 3.2.16.2.1 Make(s): ...
    - 3.2.16.2.2 Type(s): ...
    - 3.2.16.2.3 Emission-related adjustment possibilities: ...
  - 3.2.16.3. Further documentation
    - 3.2.16.3.1 Description of the safeguarding of the catalyst at switch-over from petrol to NG or back: ...
    - 3.2.16.3.2 System lay-out (electrical connections, vacuum connections compensation hoses, etc.): ...
    - 3.2.16.3.3 Drawing of the symbol: ...
- [<sup>F63</sup>3.2.17. Specific information related to gas and dual-fuel engines for heavy-duty vehicles (in the case of systems laid out in a different manner, supply equivalent information)(if applicable)]
  - 3.2.17.1. Fuel: LPG/NG-H/NG-L/NG-HL<sup>(19)</sup>
  - 3.2.17.2. Pressure regulator(s) or vaporiser/pressure regulator(s)<sup>(19)</sup>
    - 3.2.17.2.1 Make(s): ...
    - 3.2.17.2.2 Type(s): ...
    - 3.2.17.2.3 Number of pressure reduction stages: ...

---

*Status: EU Directives are being published on this site to aid cross referencing from UK legislation. After IP completion day (31 December 2020 11pm) no further amendments will be applied to this version.*

---

#### 3.2.17.2.4 Pressure in final stage

minimum: ..... kPa — maximum: .... kPa

#### 3.2.17.2.5 Number of main adjustment points: ...

#### 3.2.17.2.6 Number of idle adjustment points: ...

#### 3.2.17.2.7 Type-approval number: ...

#### 3.2.17.3. Fuelling system: mixing unit/gas injection/liquid injection/direct injection<sup>(19)</sup>

#### 3.2.17.3.1 Mixture strength regulation: ...

#### 3.2.17.3.2 System description and/or diagram and drawings: ...

#### 3.2.17.3.3 Type-approval number: ...

#### 3.2.17.4. Mixing unit

#### 3.2.17.4.1 Number: ...

#### 3.2.17.4.2 Make(s): ...

#### 3.2.17.4.3 Type(s): ...

#### 3.2.17.4.4 Location: ...

#### 3.2.17.4.5 Adjustment possibilities: ...

#### 3.2.17.4.6 Type-approval number: ...

#### 3.2.17.5. Inlet manifold injection

#### 3.2.17.5.1 Injection: single point/multipoint<sup>(19)</sup>

#### 3.2.17.5.2 Injection: continuous/simultaneously timed/sequentially timed<sup>(19)</sup>

#### 3.2.17.5.3 Injection equipment

#### 3.2.17.5.3.1 Make(s): ...

#### 3.2.17.5.3.2 Type(s): ...

#### 3.2.17.5.3.3 Adjustment possibilities: ...

#### 3.2.17.5.3.4 Type-approval number: ...

#### 3.2.17.5.4 Supply pump (if applicable)

#### 3.2.17.5.4.1 Make(s): ...

#### 3.2.17.5.4.2 Type(s): ...

#### 3.2.17.5.4.3 Type-approval number: ...

#### 3.2.17.5.5 Injector(s) ...

#### 3.2.17.5.5.1 Make(s): ...

#### 3.2.17.5.5.2 Type(s): ...

3.2.17.5.1 Type-approval number: ...

3.2.17.6. Direct injection

3.2.17.6.1 Injection pump/pressure regulator<sup>(19)</sup>

3.2.17.6.1.1 Make(s): ...

3.2.17.6.1.2 Type(s): ...

3.2.17.6.1.3 Injection timing: ...

3.2.17.6.1.4 Type-approval number: ...

3.2.17.6.2 Injector(s) ...

3.2.17.6.2.1 Make(s): ...

3.2.17.6.2.2 Type(s): ...

3.2.17.6.2.3 Opening pressure or characteristic diagram<sup>(47)</sup>: ...

3.2.17.6.2.4 Type-approval number: ...

3.2.17.7. Electronic control unit (ECU)

3.2.17.7.1 Make(s): ...

3.2.17.7.2 Type(s): ...

3.2.17.7.3 Adjustment possibilities: ...

3.2.17.7.4 Software calibration number(s): ...

3.2.17.8. NG fuel-specific equipment

3.2.17.8.1 Variant 1 (only in the case of approvals of engines for several specific fuel compositions)

[<sup>F8</sup>3.2.17.8.1.1 (Euro VI only) Self adaptive feature? Yes/No (<sup>1</sup>)

3.2.17.8.1.2 (Euro VI only) Calibration for a specific gas composition NG-H/NG-L/NG-HL (<sup>1</sup>)

Transformation for a specific gas composition NG-H<sub>t</sub>/NG-L<sub>t</sub>/NG-HL<sub>t</sub> (<sup>1</sup>)]

3.2.17.8.1 Fuel composition:

methane (CH <sub>4</sub> ):	basis: ..... % mole	min. .... % mole	max. .... % mole
ethane (C <sub>2</sub> H <sub>6</sub> ):	basis: ..... % mole	min. .... % mole	max. .... % mole
propane (C <sub>3</sub> H <sub>8</sub> ):	basis: ..... % mole	min. .... % mole	max. .... % mole
butane (C <sub>4</sub> H <sub>10</sub> ):	basis: ..... % mole	min. .... % mole	max. .... % mole
C <sub>5</sub> /C <sub>5</sub> +	basis: ..... % mole	min. .... % mole	max. .... % mole
oxygen (O <sub>2</sub> ):	basis: ..... % mole	min. .... % mole	max. .... % mole
inert (N <sub>2</sub> , He, etc.):	basis: ..... % mole	min. .... % mole	max. .... % mole

---

*Status: EU Directives are being published on this site to aid cross referencing from UK legislation. After IP completion day (31 December 2020 11pm) no further amendments will be applied to this version.*

---

- 3.2.17.8. ~~II~~ Injector(s)
- 3.2.17.8. ~~IM~~ Make(s): ...
- 3.2.17.8. ~~IT~~ Type(s): ...
- 3.2.17.8. ~~IO~~ Others (if applicable): ...
- 3.2.17.8. ~~IV~~ Variant 2 (only in the case of approvals for several specific fuel compositions)
- [<sup>F73</sup>3.2.17.9] When appropriate, manufacturer reference of the documentation for installing the dual-fuel engine in a vehicle<sup>(44)</sup>
- 3.2.18. Hydrogen fuelling system: yes/no<sup>(19)</sup>
  - 3.2.18.1. EC type-approval number in accordance with Regulation (EC) No 79/2009: ...
  - 3.2.18.2. Electronic engine management control unit for hydrogen fuelling
    - 3.2.18.2. ~~IM~~ Make(s): ...
    - 3.2.18.2. ~~IT~~ Type(s): ...
    - 3.2.18.2. ~~IE~~ Emission-related adjustment possibilities: ...
  - 3.2.18.3. Further documentation
    - 3.2.18.3. ~~ID~~ Description of the safeguarding of the catalyst at switch-over from petrol to hydrogen or back: ...
    - 3.2.18.3. ~~IS~~ System lay-out (electrical connections, vacuum connections compensation hoses, etc.): ...
    - 3.2.18.3. ~~ID~~ Drawing of the symbol: ...
- 3.2.19. H<sub>2</sub>NG fuelling system: yes/no<sup>(1)</sup>
  - 3.2.19.1. Percentage of hydrogen in the fuel (the maximum specified by the manufacturer): ...
  - 3.2.19.2. EC type-approval number in accordance with UNECE Regulation No 110 ...
  - 3.2.19.3. Electronic engine management control unit for H<sub>2</sub>NG fuelling
    - 3.2.19.3. ~~IM~~ Make(s): ...
    - 3.2.19.3. ~~IT~~ Type(s): ...
    - 3.2.19.3. ~~IE~~ Emission-related adjustment possibilities: ...
  - 3.2.19.4. Further documentation
    - 3.2.19.4. ~~ID~~ Description of the safeguarding of the catalyst at switch-over from petrol to H<sub>2</sub>NG or back: ...
    - 3.2.19.4. ~~IS~~ System lay-out (electrical connections, vacuum connections compensation hoses, etc.): ...
    - 3.2.19.4. ~~ID~~ Drawing of the symbol: ...]
- 3.3. Electric motor

3.3.1. *Type* (winding, excitation): ...

3.3.1.1. Maximum hourly output: ..... kW

[<sup>F10</sup>3.3.1.1. Maximum net power<sup>(48)</sup> ... kW

(manufacturer's declared value)

#### Textual Amendments

**F10** Inserted by Commission Regulation (EU) No 136/2014 of 11 February 2014 amending Directive 2007/46/EC of the European Parliament and of the Council, Commission Regulation (EC) No 692/2008 as regards emissions from light passenger and commercial vehicles (Euro 5 and Euro 6) and Commission Regulation (EU) No 582/2011 as regards emissions from heavy duty vehicles (Euro VI) (Text with EEA relevance).

3.3.1.1.2. Maximum 30 minutes power<sup>(48)</sup> ... kW

(manufacturer's declared value)]

3.3.1.2. Operating voltage: ..... V

3.3.2. Battery

3.3.2.1. Number of cells: ...

3.3.2.2. Mass: ..... kg

3.3.2.3. Capacity: ..... Ah (Amp-hours)

3.3.2.4. Position: ...

3.4. Engine or motor combination

3.4.1. *Hybrid electric vehicle: yes/no*<sup>(19)</sup>

3.4.2. *Category of hybrid electric vehicle: off-vehicle charging/not off-vehicle charging*.<sup>(19)</sup>

3.4.3. Operating mode switch: with/without<sup>(19)</sup>

3.4.3.1. Selectable modes

3.4.3.1.1. Pure electric: yes/no<sup>(19)</sup>

3.4.3.1.2. Pure fuel consuming: yes/no<sup>(19)</sup>

3.4.3.1.3. Hybrid modes: yes/no<sup>(19)</sup>

(if yes, short description): ...

3.4.4. Description of the energy storage device: (battery, capacitor, flywheel/generator)

3.4.4.1. Make(s): ...

3.4.4.2. Type(s): ...

3.4.4.3. Identification number: ...

---

*Status: EU Directives are being published on this site to aid cross referencing from UK legislation. After IP completion day (31 December 2020 11pm) no further amendments will be applied to this version.*

---

- 3.4.4.4. Kind of electrochemical couple: ...
- 3.4.4.5. Energy: ... (for battery: voltage and capacity Ah in 2 h, for capacitor: J,...)
- 3.4.4.6. Charger: on board/external/without<sup>(19)</sup>
- 3.4.5. Electric motor (describe each type of electric motor separately)
  - 3.4.5.1. Make: ...
  - 3.4.5.2. Type: ...
  - 3.4.5.3. Primary use: traction motor/generator<sup>(19)</sup>
    - 3.4.5.3.1. When used as traction motor: single-/multimotors (number)<sup>(19)</sup>: ...
  - 3.4.5.4. Maximum power: ..... kW
  - 3.4.5.5. Working principle
    - 3.4.5.5.1. Direct current/alternating current/number of phases: ...
    - 3.4.5.5.2. Separate excitation/series/compound<sup>(19)</sup>
    - 3.4.5.5.3. Synchronous/asynchronous<sup>(19)</sup>
- 3.4.6. Control unit
  - 3.4.6.1. Make(s): ...
  - 3.4.6.2. Type(s): ...
  - 3.4.6.3. Identification number: ...
- 3.4.7. Power controller
  - 3.4.7.1. Make: ...
  - 3.4.7.2. Type: ...
  - 3.4.7.3. Identification number: ...
- [<sup>F6</sup>3.4.8. Vehicle electric range ... km (in accordance with Annex 9 to UNECE Regulation No 101)]
- 3.4.9. *Manufacturer's recommendation for preconditioning: ...*
- 3.5. CO<sub>2</sub> emissions/fuel consumption <sup>(52)</sup> (manufacturer's declared value)
  - 3.5.1. CO<sub>2</sub> mass emissions
    - 3.5.1.1. CO<sub>2</sub> mass emissions (urban conditions): ..... g/km
    - 3.5.1.2. CO<sub>2</sub> mass emissions (extra-urban conditions): ..... g/km
    - 3.5.1.3. CO<sub>2</sub> mass emissions (combined): ..... g/km
  - 3.5.2. Fuel consumption (provide details for each reference fuel tested)
    - [<sup>F6</sup>3.5.2.1 Fuel consumption (urban conditions) ... l/100 km or m<sup>3</sup>/100 km or kg/100 km<sup>(19)</sup>



- 3.5.2.2. Fuel consumption (extra-urban conditions) ... l/100 km or m<sup>3</sup>/100 km or kg/100 km<sup>(19)</sup>
- 3.5.2.3. Fuel consumption (combined) ... l/100 km or m<sup>3</sup>/100 km or kg/100 km<sup>(19)</sup>
- [<sup>F7</sup>3.5.3. Electric energy consumption for electric vehicles
- 3.5.3.1. Electric energy consumption for pure electric vehicles ... Wh/km
- 3.5.3.2. Electric energy consumption for externally chargeable hybrid electric vehicles
- 3.5.3.2.1. Electric energy consumption (Condition A, combined) ... Wh/km
- 3.5.3.2.2. Electric energy consumption (Condition B, combined) ... Wh/km
- 3.5.3.2.3. Electric energy consumption (weighted combined) ... Wh/km]
- [<sup>F8</sup>3.5.4. CO<sub>2</sub> emissions for heavy duty engines (Euro VI only)
- [<sup>F6</sup>3.5.4.1. CO<sub>2</sub> mass emissions WHSC test<sup>(53)</sup>: ... g/kWh
- 3.5.4.2. CO<sub>2</sub> mass emissions WHSC test in diesel mode<sup>(54)</sup>: ... g/kWh]
- [<sup>F7</sup>3.5.4.3. CO<sub>2</sub> mass emissions WHSC test in dual-fuel mode<sup>(44)</sup>: ... g/kWh
- 3.5.4.4. CO<sub>2</sub> mass emissions WHTC test<sup>(53)(55)</sup>: ... g/kWh
- 3.5.4.5. CO<sub>2</sub> mass emissions WHTC test in diesel mode<sup>(54)(55)</sup>: ... g/kWh
- 3.5.4.6. CO<sub>2</sub> mass emissions WHTC test in dual-fuel mode<sup>(44)(55)</sup>: ... g/kWh]
- 3.5.5. Fuel consumption for heavy duty engines (Euro VI only)
- [<sup>F6</sup>3.5.5.1. Fuel consumption WHSC test<sup>(53)</sup>: ... g/kWh
- 3.5.5.2. Fuel consumption WHSC test in diesel mode<sup>(54)</sup>: ... g/kWh]
- [<sup>F7</sup>3.5.5.3. Fuel consumption WHSC test in dual-fuel mode<sup>(44)</sup>: ... g/kWh
- 3.5.5.4. Fuel consumption WHTC test<sup>(55)(53)</sup>: ... g/kWh
- 3.5.5.5. Fuel consumption WHTC test in diesel mode<sup>(55)(54)</sup>: ... g/kWh
- 3.5.5.6. Fuel consumption WHTC test in dual-fuel mode<sup>(55)(44)</sup>: ... g/kWh]]
- [<sup>F12</sup>[<sup>F13</sup>3.5.5. Vehicle fitted with an eco-innovation within the meaning of Article 12 of Regulation (EC) No 443/2009 for M<sub>1</sub> vehicles or Article 12 of Regulation (EU) No 510/2011 for N<sub>1</sub> vehicles: yes/no (<sup>1</sup>)
- 3.5.6.1. Type/Variant/Version of the baseline vehicle as referred to in Article 5 of Regulation (EU) No 725/2011 for M<sub>1</sub> vehicles or Article 5 of Regulation (EU) No 427/2014 for N<sub>1</sub> vehicles (if applicable) ...]
- 3.5.6.2. Existence of interactions between different eco-innovations: yes/no (<sup>1</sup>)
- 3.5.6.3. Emissions data related to the use of eco-innovations (repeat the table for each reference fuel tested)<sup>(56)</sup>

*Status: EU Directives are being published on this site to aid cross referencing from UK legislation. After IP completion day (31 December 2020 11pm) no further amendments will be applied to this version.*

Decision approving the eco-innovation <sup>b</sup>	Code of the eco-innovation <sup>c</sup>	1.CO <sub>2</sub> emissions of the baseline vehicle (g/km)	2.CO <sub>2</sub> emissions of the eco-innovation vehicle (g/km)	3.CO <sub>2</sub> emissions of the baseline vehicle under Type 1 test-cycle <sup>d</sup>	4.CO <sub>2</sub> emissions of the eco-innovation vehicle under Type 1 test-cycle (= 3.5.1.3)	5.Usage factor (UF), i.e. temporal share of technology usage in normal operation conditions	CO <sub>2</sub> emissions savings ((1 - 2) - (3 - 4)) * 5
xxxx/201x							
Total CO <sub>2</sub> emissions savings (g/km) <sup>e</sup>							
a	( <sup>w</sup> )	Eco-innovations.					
b	( <sup>w2</sup> )	Number of the Commission Decision approving the eco-innovation.					
c	( <sup>w3</sup> )	Assigned in the Commission Decision approving the eco-innovation.					
d	( <sup>w4</sup> )	Under agreement of the type-approval authority, if a modelling methodology is applied instead of the type 1 test cycle, this value shall be the one provided by the modelling methodology.					
e	( <sup>w5</sup> )	Sum of the CO <sub>2</sub> emissions savings of each individual eco-innovation.]					

#### Textual Amendments

**F12** Inserted by Commission Regulation (EU) No 195/2013 of 7 March 2013 amending Directive 2007/46/EC of the European Parliament and of the Council and Commission Regulation (EC) No 692/2008 as concerns innovative technologies for reducing CO<sub>2</sub> emissions from light passenger and commercial vehicles (Text with EEA relevance).

**F13** Substituted by Commission Regulation (EU) 2015/45 of 14 January 2015 amending Directive 2007/46/EC of the European Parliament and of the Council and Commission Regulation (EC) No 692/2008 as regards innovative technologies for reducing CO<sub>2</sub> emissions from light commercial vehicles (Text with EEA relevance).

3.6. Temperatures permitted by the manufacturer

3.6.1. Cooling system

3.6.1.1. *Liquid cooling*

Maximum temperature at outlet: ..... K

3.6.1.2. *Air cooling*

3.6.1.2.1. Reference point: ...

3.6.1.2.2. Maximum temperature at reference point: ..... K

3.6.2. *Maximum outlet temperature of the inlet intercooler: ..... K*

3.6.3. *Maximum exhaust temperature at the point in the exhaust pipe(s) adjacent to the outer flange(s) of the exhaust manifold or turbocharger: ..... K*

3.6.4. Fuel temperature

Minimum: ..... K — maximum: ..... K

For diesel engines at injection pump inlet, for gas fuelled engines at pressure regulator final stage

3.6.5. Lubricant temperature

Minimum: .... K — maximum: ..... K

3.6.6. Fuel pressure

Minimum: ..... kPa — maximum: ..... kPa

At pressure regulator final stage, NG fuelled gas engines only.

3.7. Engine-driven equipment

Power absorbed by the auxiliaries needed for operating the engine as specified in and under the operation conditions of Directive 80/1269/EEC, Annex I, Section 5.1.1.

Equipment	Power absorbed (kW) at various engine speeds						Ref. speed <sup>b</sup>
	Idle	Low speed	High speed	Speed A <sup>a</sup>	Speed B <sup>a</sup>	Speed C <sup>a</sup>	
P(a)							
Auxiliaries needed for operating the engine (to be subtracted from measured engine power) see Appendix 1, Section 6.1.							

<sup>a</sup> ESC test.

<sup>b</sup> ETC test only.

3.8. Lubrication system

3.8.1. Description of the system

3.8.1.1. Position of lubricant reservoir: ...

3.8.1.2. Feed system (by pump/injection into intake/mixing with fuel, etc.)<sup>(19)</sup>

---

*Status: EU Directives are being published on this site to aid cross referencing from UK legislation. After IP completion day (31 December 2020 11pm) no further amendments will be applied to this version.*

---

### 3.8.2. Lubricating pump

3.8.2.1. Make(s): ...

3.8.2.2. Type(s): ...

### 3.8.3. Mixture with fuel

3.8.3.1. Percentage: ...

3.8.4. Oil cooler: yes/no<sup>(19)</sup>

3.8.4.1. Drawing(s): ..... or

3.8.4.1.1. Make(s): ...

3.8.4.1.2. Type(s): ...

## 4. TRANSMISSION<sup>(57)</sup>

4.1. **Drawing of the transmission:** ...

4.2. **Type (mechanical, hydraulic, electric, etc.):** ...

4.2.1. A brief description of the electrical/electronic components (if any): ...

4.3. **Moment of inertia of engine flywheel:** ...

4.3.1. Additional moment of inertia with no gear engaged: ...

4.4. Clutch

4.4.1. Type: ...

4.4.2. Maximum torque conversion: ...

4.5. Gearbox

4.5.1. Type (manual/automatic/CVT (continuously variable transmission))<sup>(19)</sup>

4.5.2. Location relative to the engine: ...

4.5.3. Method of control: ...

4.6. Gear ratios

<b>Gear</b>	<b>Internal gearbox ratios (ratios of engine to gearbox output shaft revolutions)</b>	<b>Final drive ratio(s) (ratio of gearbox output shaft to driven wheel revolutions)</b>	<b>Total gear ratios</b>
Maximum for CVT <sup>a</sup>			
1			
2			
3			

**a** Continuously variable transmission.

---

**Status:** EU Directives are being published on this site to aid cross referencing from UK legislation. After IP completion day (31 December 2020 11pm) no further amendments will be applied to this version.

...			
Minimum for CVT <sup>a</sup>			
Reverse			

**a** Continuously variable transmission.

- 4.7. **Maximum vehicle design speed (in km/h)<sup>(58)</sup>:** ...
- 4.8. Speedometer
- 4.8.1. Method of operation and description of drive mechanism: ...
- 4.8.2. Instrument constant: ...
- 4.8.3. Tolerance of the measuring mechanism (pursuant to item 2.1.3 of Annex II to Directive 75/443/EEC): ...
- 4.8.4. Overall transmission ratio (pursuant to item 2.1.2 of Annex II to Directive 75/443/EEC) or equivalent data: ...
- 4.8.5. Diagram of the speedometer scale or other forms of display: ...
- 4.9. Tachograph: yes/no<sup>(19)</sup>
- 4.9.1 Approval mark: ...
- 4.10. **Differential lock: yes/no/optional<sup>(19)</sup>**
- [<sup>F14</sup>4.11. Gear shift indicator (GSI)
- 4.11.1. Acoustic indication available yes/no (<sup>1</sup>). If yes, description of sound and sound level at the driver's ear in dB(A). (Acoustic indication always switchable on/off)
- 4.11.2. Information according to point 4.6 of Annex I to Regulation (EU) No 65/2012 (manufacturer's declared value)
- 4.11.3. Photographs and/or drawings of the gear shift indicator instrument and brief description of the system components and operation:]

#### Textual Amendments

**F14** Inserted by [Commission Regulation \(EU\) No 65/2012 of 24 January 2012 implementing Regulation \(EC\) No 661/2009 of the European Parliament and of the Council as regards gear shift indicators and amending Directive 2007/46/EC of the European Parliament and of the Council \(Text with EEA relevance\).](#)

5. AXLES
- 5.1. Description of each axle: ...
- 5.2. Make: ...
- 5.3. Type: ...
- 5.4. Position of retractable axle(s): ...
- 5.5. Position of loadable axle(s): ...

---

*Status: EU Directives are being published on this site to aid cross referencing from UK legislation. After IP completion day (31 December 2020 11pm) no further amendments will be applied to this version.*

---

## 6. SUSPENSION

- 6.1. Drawing of the suspension arrangements: ...
- 6.2. Type and design of the suspension of each axle or group of axles or wheel: ...
  - 6.2.1. Level adjustment: yes/no/optional<sup>(19)</sup>
  - 6.2.2. A brief description of the electrical/electronic components (if any): ...
  - 6.2.3. Air-suspension for driving axle(s): yes/no<sup>(19)</sup>
    - 6.2.3.1. Suspension of driving axle(s) equivalent to air-suspension: yes/no<sup>(19)</sup>
    - 6.2.3.2. Frequency and damping of the oscillation of the sprung mass: ...
  - 6.2.4. Air-suspension for non-driving axle(s): yes/no<sup>(19)</sup>
    - 6.2.4.1. Suspension of non-driving axle(s) equivalent to air-suspension: yes/no<sup>(19)</sup>
    - 6.2.4.2. Frequency and damping of the oscillation of the sprung mass: ...
- 6.3. **Characteristics of the springing parts of the suspension** (design, characteristics of the materials and dimensions): ...
- 6.4. **Stabilisers:** yes/no/optional<sup>(19)</sup>
- 6.5. **Shock absorbers:** yes/no/optional<sup>(19)</sup>
- 6.6. Tyres and wheels
  - 6.6.1. Tyre/wheel combination(s)
    - (a) for tyres indicate size designation, load-capacity index, speed category symbol, rolling resistance in accordance with ISO 28580 (where applicable)<sup>(59)</sup>;
    - (b) for wheels indicate rim size(s) and off-set(s)
  - 6.6.1.1. Axles
    - 6.6.1.1.1. Axle 1: ...
    - 6.6.1.1.2. Axle 2: ...
    - etc.
  - 6.6.1.2. Spare wheel, if any: ...
  - 6.6.2. Upper and lower limits of rolling radii
    - 6.6.2.1. Axle 1: ...
    - 6.6.2.2. Axle 2: ...
    - 6.6.2.3. Axle 3: ...
    - 6.6.2.4. Axle 4: ...
    - etc.
  - 6.6.3. *Tyre pressure(s) as recommended by the vehicle manufacturer: ..... kPa*

- 6.6.4. *Chain/tyre/wheel combination on the front and/or rear axle that is suitable for the type of vehicle, as recommended by the manufacturer: ...*
- 6.6.5. *Brief description of temporary use spare unit (if any): ...*
- 7. STEERING
  - 7.1. **Schematic diagram of steered axle(s) showing steering geometry: ...**
  - 7.2. Transmission and control
    - 7.2.1. Type of steering transmission (specify for front and rear, if applicable): ...
    - 7.2.2. Linkage to wheels (including other than mechanical means; specify for front and rear, if applicable): ...
      - 7.2.2.1. A brief description of the electrical/electronic components (if any): ...
    - 7.2.3. Method of assistance (if any): ...
      - 7.2.3.1. Method and diagram of operation, make(s) and type(s): ...
    - 7.2.4. Diagram of the steering equipment as a whole, showing the position on the vehicle of the various devices influencing its steering behaviour: ...
    - 7.2.5. Schematic diagram(s) of the steering control(s): ...
    - 7.2.6. Range and method of adjustment (if any), of the steering control: ...
  - 7.3. Maximum steering angle of the wheels
    - 7.3.1. To the right: ... degrees; number of turns of the steering wheel (or equivalent data): ...
    - 7.3.2. To the left: ... degrees; number of turns of the steering wheel (or equivalent data): ...
- 8. BRAKES

(The following particulars, including means of identification, where applicable, are to be given)

- 8.1. Type and characteristics of the brakes as defined in point 1.6 of Annex I to Council Directive 71/320/EEC (OJ L 205, 6.9.1971, p. 37) including details and drawings of the drums, discs, hoses make and type of shoe/pad assemblies and/or linings, effective braking areas, radius of drums, shoes or discs, mass of drums, adjustment devices, relevant parts of the axle(s) and suspension: ...
- 8.2. Operating diagram, description and/or drawing of the braking system described in point 1.2 of Annex I to Directive 71/320/EEC including details and drawings of the transmission and controls:
  - 8.2.1. Service braking system: ...
  - 8.2.2. Secondary braking system: ...
  - 8.2.3. Parking braking system: ...
  - 8.2.4. Any additional braking system: ...
  - 8.2.5. Break-away braking system: ...

---

*Status: EU Directives are being published on this site to aid cross referencing from UK legislation. After IP completion day (31 December 2020 11pm) no further amendments will be applied to this version.*

---

- 8.3. Control and transmission of trailer braking systems in vehicles designed to tow a trailer: ...
- 8.4. Vehicle is equipped to tow a trailer with electric/pneumatic/hydraulic<sup>(19)</sup> service brakes: yes/no<sup>(19)</sup>
- 8.5. Anti-lock braking system: yes/no/optional<sup>(19)</sup>
- 8.5.1. For vehicles with anti-lock systems, description of system operation (including any electronic parts), electric block diagram, hydraulic or pneumatic circuit plan: ...
- 8.6. Calculation and curves according to the Appendix to point 1.1.4.2 of the Appendix to Annex II to Directive 71/320/EEC or to the Appendix to Annex XI thereto, if applicable: ...
- 8.7. Description and/or drawing of the energy supply, also to be specified for power-assisted braking systems: ...
- 8.7.1. In the case of compressed-air braking systems, working pressure p<sub>2</sub> in the pressure reservoir(s): ...
- 8.7.2. In the case of vacuum braking systems, the initial energy level in the reservoir(s): ...
- 8.8. Calculation of the braking system: Determination of the ratio between the total braking forces at the circumference of the wheels and the force applied to the braking control: ...
- 8.9. Brief description of the braking system according to point 1.6 of the Addendum to Appendix 1 of Annex IX to Directive 71/320/EEC: ...
- 8.10. If claiming exemptions from the Type I and/or Type II or Type III tests, state the number of the report in accordance with Appendix 2 of Annex VII to Directive 71/320/EEC: ...
- 8.11. Particulars of the type(s) of endurance braking system(s): ...
- 9. BODYWORK
- 9.1. Type of bodywork using the codes defined in Part C of Annex II: ...
- 9.2. Materials used and methods of construction: ...
- 9.3. Occupant doors, latches and hinges
- 9.3.1. Door configuration and number of doors: ...
- 9.3.1.1. Dimensions, direction and maximum angle of opening: ...
- 9.3.2. Drawing of latches and hinges and of their position in the doors: ...
- 9.3.3. Technical description of latches and hinges: ...
- 9.3.4. Details, including dimensions, of entrances, steps and necessary handles where applicable: ...
- 9.4. Field of vision



- 9.4.1. Particulars of the primary reference marks in sufficient detail to enable them to be readily identified and the position of each in relation to the others and to the R-point to be verified: ...
- 9.4.2. Drawing(s) or photograph(s) showing the location of component parts within the 180° forward field of vision: ...
- 9.5. Windscreen and other windows
  - 9.5.1. Windscreen
    - 9.5.1.1. Materials used: ...
    - 9.5.1.2. Method of mounting: ...
    - 9.5.1.3. Angle of inclination: ...
    - 9.5.1.4. Type-approval number(s): ...
    - 9.5.1.5. Windscreen accessories and the position in which they are fitted together with a brief description of any electrical/electronic components involved: ...
  - 9.5.2. Other windows
    - 9.5.2.1. Materials used: ...
    - 9.5.2.2. Type-approval number(s): ...
    - 9.5.2.3. A brief description of the electrical/electronic components (if any) of the window lifting mechanism: ...
  - 9.5.3. Opening roof glazing
    - 9.5.3.1. Materials used: ...
    - 9.5.3.2. Type-approval number(s): ...
  - 9.5.4. Other glass panes
    - 9.5.4.1. Materials used: ...
    - 9.5.4.2. Type-approval number(s): ...
- 9.6. Windscreen wiper(s)
  - 9.6.1. Detailed technical description (including photographs or drawings): ...
- 9.7. Windscreen washer
  - 9.7.1. Detailed technical description (including photographs or drawings) or, if approved as separate technical unit, type-approval number: ...
- 9.8. Defrosting and demisting
  - 9.8.1. Detailed technical description (including photographs or drawings): ...
  - 9.8.2. Maximum electrical consumption: ... kW
- 9.9. Devices for indirect vision
  - 9.9.1. Rear-view mirrors, stating for each mirror:

---

*Status: EU Directives are being published on this site to aid cross referencing from UK legislation. After IP completion day (31 December 2020 11pm) no further amendments will be applied to this version.*

---

- 9.9.1.1. Make: ...
- 9.9.1.2. Type-approval mark: ...
- 9.9.1.3. Variant: ...
- 9.9.1.4. Drawing(s) for the identification of the mirror showing the position of the mirror relative to the vehicle structure: ...
- 9.9.1.5. Details of the method of attachment including that part of the vehicle structure to which it is attached: ...
- 9.9.1.6. Optional equipment which may affect the rearward field of vision: ...
- 9.9.1.7. A brief description of the electronic components (if any) of the adjustment system: ...
- 9.9.2. Devices for indirect vision other than mirrors: ...
  - 9.9.2.1. Type and characteristics (such as a complete description of the device): ...
    - 9.9.2.1.1. In the case of a camera-monitor device, the detection distance (mm), contrast, luminance range, glare correction, display performance (black and white/colour), image repetition frequency, luminance reach of the monitor: ...
    - 9.9.2.1.2. Sufficiently detailed drawings to identify the complete device, including installation instructions; the position for the EC type-approval mark has to be indicated on the drawings.
- 9.10. Interior arrangement
  - 9.10.1. Interior protection for occupants
    - 9.10.1.1. Layout drawing or photographs showing the position of the attached sections or views: ...
    - 9.10.1.2. Photograph or drawing showing the reference zone including the exempted area referred to in point 2.3.1 of Annex I to Council Directive 74/60/EEC ([OJ L 38, 11.2.1974, p. 2](#)): ...
    - 9.10.1.3. Photographs, drawings and/or an exploded view of the interior fittings, showing the parts in the passenger compartment and the materials used (with the exception of interior rear view mirrors), arrangement of controls, roof and opening roof, backrest, seats and the rear part of seats: ...
  - 9.10.2. Arrangement and identification of controls, tell-tales and indicators
    - 9.10.2.1. Photographs and/or drawings of the arrangement of symbols and controls, tell-tales and indicators: ...
    - 9.10.2.2. Photographs and/or drawings of the identification of controls, tell-tales and indicators and of the vehicle parts referred to in Annex II and III of Directive 78/316/EEC where relevant: ...
    - 9.10.2.3. *Summary table*

The vehicle is equipped with the following controls, indicators and tell-tales pursuant to Annexes II and III to Directive 78/316/EEC

**Status:** EU Directives are being published on this site to aid cross referencing from UK legislation. After IP completion day (31 December 2020 11pm) no further amendments will be applied to this version.

**CONTROLS, TELL-TALES AND INDICATORS FOR WHICH,  
WHEN FITTED, IDENTIFICATION IS MANDATORY,  
AND SYMBOLS TO BE USED FOR THAT PURPOSE**

<b>Symbol No</b>	<b>Device</b>	<b>Control/indicator available<sup>a</sup></b>	<b>Identified by symbol<sup>a</sup></b>	<b>Where<sup>b</sup></b>	<b>Tell-tale available<sup>a</sup></b>	<b>Identified by symbol<sup>a</sup></b>	<b>Where<sup>b</sup></b>
1	Master light						
2	Dipped-beam headlamps						
3	Main-beam headlamps						
4	Position (side) lamps						
5	Front fog lamps						
6	Rear fog lamp						
7	Headlamp levelling device						
8	Parking lamps						
9	Direction indicators						
10	Hazard warning						
11	Windscreen wiper						
12	Windscreen washer						
13	Windscreen wiper and washer						
<b>a</b>	x	=	yes				
	—	=	no or not separately available				
	o	=	optional.				
<b>b</b>	d	=	directly on control, indicator or tell-tale				
	c	=	in close vicinity.				

*Status: EU Directives are being published on this site to aid cross referencing from UK legislation. After IP completion day (31 December 2020 11pm) no further amendments will be applied to this version.*

14	Headlamp cleaning device						
15	Windscreen demisting and defrosting						
16	Rear window demisting and defrosting						
17	Ventilating fan						
18	Diesel pre-heat						
19	Choke						
20	Brake failure						
21	Fuel level						
22	Battery charging condition						
23	Engine coolant temperature						
<b>a</b>	x	=	yes				
	—	=	no or not separately available				
	o	=	optional.				
<b>b</b>	d	=	directly on control, indicator or tell-tale				
	c	=	in close vicinity.				

**CONTROLS, TELL-TALES AND INDICATORS FOR WHICH,  
WHEN FITTED, IDENTIFICATION IS OPTIONAL, AND SYMBOLS  
WHICH SHALL BE USED IF THEY ARE TO BE IDENTIFIED**

<b>Symbol No</b>	<b>Device</b>	<b>Control/indicator available<sup>a</sup></b>	<b>Identified by symbol<sup>a</sup></b>	<b>Where<sup>b</sup></b>	<b>Tell-tale available<sup>a</sup></b>	<b>Identified by symbol<sup>a</sup></b>	<b>Where<sup>b</sup></b>
1	Parking brake						
<b>a</b>	x	=	yes				
	—	=	no or not separately available				
	o	=	optional.				
<b>b</b>	d	=	directly on control, indicator or tell-tale				
	c	=	in close vicinity.				

*Status: EU Directives are being published on this site to aid cross referencing from UK legislation. After IP completion day (31 December 2020 11pm) no further amendments will be applied to this version.*

2	Rear window wiper						
3	Rear window washer						
4	Rear window wiper and washer						
5	Intermittent windscreen wiper						
6	Audible warning device (horn)						
7	Front hood (bonnet)						
8	Rear hood (boot)						
9	Seat-belt						
10	Engine oil pressure						
11	Unleaded petrol						
...							
...							
...							
<b>a</b>	<u>x</u>	=	yes				
	o	=	no or not separately available				
		=	optional.				
<b>b</b>	d	=	directly on control, indicator or tell-tale				
	c	=	in close vicinity.				

9.10.3. Seats

9.10.3.1. Number of seating positions<sup>(60)</sup>: ...

9.10.3.1.1. Location and arrangement: ...

9.10.3.2. Seat(s) designated for use only when the vehicle is stationary: ...

---

*Status: EU Directives are being published on this site to aid cross referencing from UK legislation. After IP completion day (31 December 2020 11pm) no further amendments will be applied to this version.*

---

- 9.10.3.3. Mass: ...
- 9.10.3.4. Characteristics: for seats not type-approved as components, description and drawings of
  - 9.10.3.4.1 The seats and their anchorages: ...
  - 9.10.3.4.2 The adjustment system: ...
  - 9.10.3.4.3 The displacement and locking systems: ...
  - 9.10.3.4.4 The seat-belt anchorages (if incorporated in the seat structure): ...
  - 9.10.3.4.5 The parts of the vehicle used as anchorages: ...
- 9.10.3.5. Coordinates or drawing of the R-point<sup>(61)</sup>
  - 9.10.3.5.1 Driver's seat: ...
  - 9.10.3.5.2 All other seating positions: ...
- 9.10.3.6. Design torso angle
  - 9.10.3.6.1 Driver's seat: ...
  - 9.10.3.6.2 All other seating positions: ...
- 9.10.3.7. Range of seat adjustment
  - 9.10.3.7.1 Driver's seat: ...
  - 9.10.3.7.2 All other seating positions: ...
- 9.10.4. Head restraints
  - 9.10.4.1. Type(s) of head restraints: integrated/detachable/separate<sup>(19)</sup>
  - 9.10.4.2. Type-approval number(s), if available: ...
  - 9.10.4.3. For head restraints not yet approved
    - 9.10.4.3.1 A detailed description of the head restraint, specifying in particular the nature of the padding material or materials and, where applicable, the position and specifications of the braces and anchorage pieces for the type of seat for which approval is sought: ...
    - 9.10.4.3.2 In the case of a 'separate' head restraint
    - 9.10.4.3.2 A detailed description of the structural zone to which the head restraint is intended to be fixed: ...
    - 9.10.4.3.2 Dimensional drawings of the characteristic parts of the structure and the head restraint: ...
- 9.10.5. Heating systems for the passenger compartment
  - 9.10.5.1. A brief description of the vehicle type with regard to the heating system if the heating system uses the heat of the engine cooling fluid: ...
  - 9.10.5.2. A detailed description of the vehicle type with regard to the heating if the cooling air or the exhaust gases of the engine are used as heat source, including:

- 9.10.5.2.1 Layout drawing of the heating system showing its position in the vehicle: ...
- 9.10.5.2.2 Layout drawing of the heat exchanger for heating systems using the exhaust gases for heating, or of the parts where the heat exchange takes place (for heating systems using the engine cooling air for heating): ...
- 9.10.5.2.3 Sectional drawing of the heat exchanger or the parts respectively where the heat exchange takes place indicating the thickness of the wall, used materials and characteristics of the surface: ...
- 9.10.5.2.4 Specifications shall be given for further important components of the heating system such as, for example, the heater fan, with regard to their method of construction and technical data: ...
- 9.10.5.3. A brief description of the vehicle type with regard to the combustion heating system and the automatic control: ...
- 9.10.5.3.1 Layout drawing of the combustion heater, the air inlet system, the exhaust system, the fuel tank, the fuel supply system (including the valves) and the electrical connections showing their positions in the vehicle.
- 9.10.5.4. Maximum electrical consumption: ..... kW
- 9.10.6. Components influencing the behaviour of the steering mechanism in the event of an impact
- 9.10.6.1. A detailed description, including photograph(s) and/or drawing(s), of the vehicle type with respect to the structure, the dimensions, the lines and the constituent materials of that part of the vehicle forward of the steering control, including those components designed to contribute to the absorption of energy in the event of an impact against the steering control: ...
- 9.10.6.2. Photograph(s) and/or drawing(s) of vehicle components other than those described in 9.10.6.1 as identified by the manufacturer in agreement with the technical service, as contributing to the behaviour of the steering mechanism in case of impact: ...
- 9.10.7. Burning behaviour of materials used in the interior construction of certain categories of motor vehicles
- 9.10.7.1. *Material(s) used for the interior lining of the roof*
- 9.10.7.1.1 Component type-approval number(s), if available: ...
- 9.10.7.1.2 For materials not approved
- 9.10.7.1.3 Base material(s)/designation: ...../.....
- 9.10.7.1.4 Composite/single<sup>(19)</sup> material, number of layers<sup>(19)</sup>: ...
- 9.10.7.1.5 Type of coating<sup>(19)</sup>: ...
- 9.10.7.1.6 Maximum/minimum thickness: ...../..... mm
- 9.10.7.2. *Material(s) used for the rear and side walls*
- 9.10.7.2.1 Component type-approval number(s), if available: ...
- 9.10.7.2.2 For materials not approved

---

*Status: EU Directives are being published on this site to aid cross referencing from UK legislation. After IP completion day (31 December 2020 11pm) no further amendments will be applied to this version.*

---

- 9.10.7.2.2 Base material(s)/designation: ...../.....
- 9.10.7.2.2 Composite/single<sup>(19)</sup> material, number of layers<sup>(19)</sup>: ...
- 9.10.7.2.2 Type of coating<sup>(19)</sup>: ...
- 9.10.7.2.2 Maximum/minimum thickness: ...../..... mm
- 9.10.7.3. *Material(s) used for the floor*
- 9.10.7.3.1 Component type-approval number(s), if available: ...
- 9.10.7.3.2 For materials not approved
- 9.10.7.3.2 Base material(s)/designation: ...../.....
- 9.10.7.3.2 Composite/single<sup>(19)</sup> material, number of layers<sup>(19)</sup>: ...
- 9.10.7.3.2 Type of coating<sup>(19)</sup>: ...
- 9.10.7.3.2 Maximum/minimum thickness: ...../..... mm
- 9.10.7.4. *Material(s) used for the upholstery of the seats*
- 9.10.7.4.1 Component type-approval number(s), if available: ...
- 9.10.7.4.2 For materials not approved
- 9.10.7.4.2 Base material(s)/designation: ...../.....
- 9.10.7.4.2 Composite/single<sup>(19)</sup> material, number of layers<sup>(19)</sup>: ...
- 9.10.7.4.2 Type of coating<sup>(19)</sup>: ...
- 9.10.7.4.2 Maximum/minimum thickness: ...../..... mm
- 9.10.7.5. *Material(s) used for the heating and ventilation pipes*
- 9.10.7.5.1 Component type-approval number(s), if available: ...
- 9.10.7.5.2 For materials not approved
- 9.10.7.5.2 Base material(s)/designation: ...../.....
- 9.10.7.5.2 Composite/single<sup>(19)</sup> material, number of layers<sup>(19)</sup>: ...
- 9.10.7.5.2 Type of coating<sup>(19)</sup>: ...
- 9.10.7.5.2 Maximum/minimum thickness: ...../..... mm
- 9.10.7.6. *Material(s) used for luggage racks*
- 9.10.7.6.1 Component type-approval number(s), if available: ...
- 9.10.7.6.2 For materials not approved
- 9.10.7.6.2 Base material(s)/designation: ...../.....
- 9.10.7.6.2 Composite/single<sup>(19)</sup> material, number of layers<sup>(19)</sup>: ...
- 9.10.7.6.2 Type of coating<sup>(19)</sup>: ...



- 9.10.7.6. ~~M~~Maximum/minimum thickness: ...../..... mm
- 9.10.7.7. *Material(s) used for other purposes*
- 9.10.7.7. ~~I~~Intended purposes: ...
- 9.10.7.7. ~~X~~Component type-approval number(s), if available: ...
- 9.10.7.7. ~~F~~For materials not approved
- 9.10.7.7. ~~B~~Base material(s)/designation: ...../.....
- 9.10.7.7. ~~C~~Composite/single<sup>(19)</sup> material, number of layers<sup>(19)</sup>: ...
- 9.10.7.7. ~~3~~Type of coating<sup>(19)</sup>: ...
- 9.10.7.7. ~~M~~Maximum/minimum thickness: ..../.... mm
- 9.10.7.8. *Components approved as complete devices (seats, separation walls, luggage racks, etc.)*
- 9.10.7.8. ~~I~~Component type-approval number(s): ...
- 9.10.7.8. ~~F~~For the complete device: seat, separation wall, luggage racks, etc.<sup>(19)</sup>
- 9.10.8 Gas used as refrigerant in the air-conditioning system: ...
- 9.10.8.1 The air-conditioning system is designed to contain fluorinated greenhouse gases with global warming potential higher than 150: yes/no<sup>(19)</sup>
- 9.10.8.2. If yes, fill in the following sections
- 9.10.8.2. ~~I~~Drawing and brief description of the air-conditioning system, including the reference or part number and material of the leak components;
- 9.10.8.2. ~~L~~Leakage of the air-conditioning system
- 9.10.8.2. ~~R~~Reference or part number and material of the components of the system and information about the test (e.g. test report number, approval number, etc.): ...
- 9.10.8.3. Overall leakage in g/year of the entire system: ...
- 9.11. External projections
- 9.11.1. General arrangement (drawing or photographs) indicating the position of the attached sections and views:
- 9.11.2. Drawings and/or photographs, for example, and where relevant, of the door and window pillars, air-intake grilles, radiator grille, windscreen wipers, rain gutter channels, handles, slide rails, flaps, door hinges and locks, hooks, eyes, decorative trim, badges, emblems and recesses and any other external projections and parts of the exterior surface which can be regarded as critical (e.g. lighting equipment). If the parts listed in the previous sentence are not critical, for documentation purposes they may be replaced by photographs, accompanied if necessary by dimensional details and/or text:
- 9.11.3. Drawings of parts of the external surface in accordance with Annex I, item 6.9.1 to Directive 74/483/EEC: ...

*Status: EU Directives are being published on this site to aid cross referencing from UK legislation. After IP completion day (31 December 2020 11pm) no further amendments will be applied to this version.*

9.11.4. Drawing of bumpers: ...

9.11.5. Drawing of the floor line: ...

9.12. Safety belts and/or other restraint systems

9.12.1. Number and position of safety belts and restraint systems and seats on which they can be used

(L = left-hand side, R = right-hand side, C = centre)

		<b>Complete EC type-approval mark</b>	<b>Variant, if applicable</b>	<b>Belt adjustment device for height (indicate yes/no/optional)</b>
First row of seats	L			
	C			
	R			
Second row of seats <sup>a</sup>	L			
	C			
	R			

**a** The table may be extended as necessary for vehicles with more than two rows of seats or if there are more than three seats across the width of the vehicle.

9.12.2. Nature and position of supplementary restraint systems (indicate yes/no/optional)

(L = left-hand side, R = right-hand side, C = centre)

		<b>Front airbag</b>	<b>Side airbag</b>	<b>Belt pre-loading device</b>
First row of seats	L			
	C			
	R			
Second row of seats <sup>a</sup>	L			
	C			
	R			

**a** The table may be extended as necessary for vehicles with more than two rows of seats or if there are more than three seats across the width of the vehicle

9.12.3. Number and position of safety belt anchorages and proof of compliance with Directive 76/115/EEC, (i.e. type-approval number or test report): ...

9.12.4. A brief description of the electrical/electronic components (if any): ...

9.13. Safety belt anchorages

**Status:** EU Directives are being published on this site to aid cross referencing from UK legislation. After IP completion day (31 December 2020 11pm) no further amendments will be applied to this version.

- 9.13.1. Photographs and/or drawings of the bodywork showing the position and dimensions of the actual and the effective anchorages including the R-points: ...
- 9.13.2. Drawings of the belt anchorages and parts of the vehicle structure where they are attached (with the material indication): ...
- 9.13.3. Designation of the types<sup>(62)</sup> of safety belt authorised for fitting to the anchorages with which the vehicle is equipped

			Anchorage location	
			Vehicle structure	Seat structure
First row of seats				
Right-hand seat	Lower anchorages	outboard inboard		
	Upper anchorages			
Centre seat	Lower anchorages	right left		
	Upper anchorages			
Left-hand seat	Lower anchorages	outboard inboard		
	Upper anchorages			
Second row of seats <sup>a</sup>				
Right-hand seat	Lower anchorages	outboard inboard		
	Upper anchorages			
Centre seat	Lower anchorages	right left		
	Upper anchorages			
Left-hand seat	Lower anchorages	outboard inboard		
	Upper anchorages			

**a** The table may be extended as necessary for vehicles with more than two rows of seats or if there are more than three seats across the width of the vehicle.

- 9.13.4. Description of a particular type of safety belt where an anchorage is located in the seat backrest or incorporates an energy dissipating device: ...

---

*Status: EU Directives are being published on this site to aid cross referencing from UK legislation. After IP completion day (31 December 2020 11pm) no further amendments will be applied to this version.*

---

- 9.14. Space for mounting rear registration plates (give range where appropriate, drawings may be used where applicable)
  - 9.14.1. Height above road surface, upper edge: ...
  - 9.14.2. Height above road surface, lower edge: ...
  - 9.14.3. Distance of the centre line from the longitudinal median plane of the vehicle: ...
  - 9.14.4. Distance from the left vehicle edge: ...
  - 9.14.5. Dimensions (length × width): ...
  - 9.14.6. Inclination of the plane to the vertical: ...
  - 9.14.7. Angle of visibility in the horizontal plane: ...
- 9.15. Rear under-run protection
  - 9.15.0. Presence: yes/no/incomplete<sup>(19)</sup>
    - 9.15.1. Drawing of the vehicle parts relevant to the rear under-run protection, i.e. drawing of the vehicle and/or chassis with position and mounting of the widest rear axle, drawing of the mounting and/or fitting of the rear under-run protection. If the under-run protection is not a special device, the drawing shall clearly show that the required dimensions are met: ...
    - 9.15.2. In case of a special device, full description and/or drawing of the rear under-run protection (including mountings and fittings), or, if approved as separate technical unit, type-approval number: ...
- 9.16. Wheel guards
  - 9.16.1. Brief description of the vehicle with regard to its wheel guards: ...
  - 9.16.2. Detailed drawings of the wheel guards and their position on the vehicle showing the dimensions specified in Figure 1 of Annex I to Directive 78/549/EEC and taking account of the extremes of tyre/wheel combinations: ...
- 9.17. Statutory plates
  - 9.17.1. Photographs and/or drawings of the locations of the statutory plates and inscriptions and of the vehicle identification number: ...
  - 9.17.2. Photographs and/or drawings of the statutory plate and inscriptions (completed example with dimensions): ...
  - 9.17.3. Photographs and/or drawings of the vehicle identification number (completed example with dimensions): ...
  - 9.17.4. Manufacturer's declaration of compliance with the requirements set out in point 3.1.1.1 of Annex to Council Directive 76/114/EEC (OJ L 24, 30.1.1976, p. 1)
    - 9.17.4.1. The meaning of characters in the second section and, if applicable, in the third section used to comply with the requirements of section 5.3 of ISO Standard 3779-1983 shall be explained: ...
    - 9.17.4.2. If characters in the second section are used to comply with the requirements of section 5.4 of ISO Standard 3779-1983 these characters shall be indicated: ...

- 9.18. Radio interference/electromagnetic compatibility
  - 9.18.1. Description and drawings/photographs of the shapes and constituent materials of the part of the body forming the engine compartment and the part of the passenger compartment nearest to it: ...
  - 9.18.2. Drawings or photographs of the position of metal components housed in the engine compartment (e.g. heating appliances, spare wheel, air filter, steering mechanism, etc.): ...
  - 9.18.3. Table and drawing of radio-interference control equipment: ...
  - 9.18.4. Particulars of the nominal value of the direct current resistance, and, in the case of resistive ignition cables, of their nominal resistance per metre: ...
- 9.19. Lateral protection
  - 9.19.0. Presence: yes/no/incomplete<sup>(19)</sup>
  - 9.19.1. Drawing of the vehicle parts relevant to the lateral protection, i.e. drawing of the vehicle and/or chassis with position and mounting of the axle(s), drawing of the mountings and/or the fittings of lateral protection device(s). If the lateral protection is achieved without lateral protection device(s) the drawing shall clearly show that the required dimensions are met: ...
  - 9.19.2. In the case of lateral protection device(s), full description and/or drawing of such device(s) (including mountings and fittings) or its/their component type-approval number(s): ...
- 9.20. Spray-suppression system
  - 9.20.0. Presence: yes/no/incomplete<sup>(19)</sup>
  - 9.20.1. Brief description of the vehicle with regard to its spray-suppression system and the constituent components: ...
  - 9.20.2. Detailed drawings of the spray-suppression system and its position on the vehicle showing the dimensions specified in the figures in Annex III to Directive 91/226/EEC and taking account of the extremes of tyre/wheel combinations: ...
  - 9.20.3. Type-approval number(s) of spray-suppression device(s), if available: ...
- 9.21. Side-impact resistance
  - 9.21.1. A detailed description, including photographs and/or drawings, of the vehicle with respect to the structure, the dimensions, the lines and the constituent materials of the side walls of the passenger compartment (exterior and interior), including specific details of the protection system, where applicable: ...
- 9.22. Front under-run protection
  - 9.22.0. Presence: yes/no/incomplete<sup>(19)</sup>
  - 9.22.1. Drawing of the vehicle parts relevant to the front under-run protection, i.e. drawing of the vehicle and/or chassis with position and mounting and/or fitting of the front under-run protection. If the under-run protection is no special device, the drawing shall clearly show that the required dimensions are met: ...

---

*Status: EU Directives are being published on this site to aid cross referencing from UK legislation. After IP completion day (31 December 2020 11pm) no further amendments will be applied to this version.*

---

9.22.2. In the case of special device, full description and/or drawing of the front under-run protection (including mountings and fittings), or, if approved as a separate technical unit, type-approval number: ...

9.23. Pedestrian protection

9.23.1. A detailed description, including photographs and/or drawings, of the vehicle with respect to the structure, the dimensions, the relevant reference lines and the constituent materials of the frontal part of the vehicle (interior and exterior), including detail of any active protection system installed.

[<sup>F15</sup>9.24. **Frontal protection systems**

9.24.1. General arrangement (drawings or photographs) indicating the position and attachment of the frontal protection systems:

9.24.2. Drawings and/or photographs, where relevant, of air intake grilles, radiator grille, decorative trim, badges, emblems and recesses and any other external projections and parts of the exterior surface which can be regarded as critical (e.g. lighting equipment). If the parts listed in the first sentence are not critical, for documentation purposes they may be replaced by photographs, accompanied if necessary by dimensional details and/or text:

9.24.3. Complete details of fittings required and full instructions, including torque requirements, for fitting:

9.24.4. Drawing of bumpers:

9.24.5. Drawing of the floor line at the vehicle front end:]

#### **Textual Amendments**

**F15** Substituted by [Regulation \(EC\) No 78/2009 of the European Parliament and of the Council of 14 January 2009 on the type-approval of motor vehicles with regard to the protection of pedestrians and other vulnerable road users, amending Directive 2007/46/EC and repealing Directives 2003/102/EC and 2005/66/EC \(Text with EEA relevance\).](#)

10. LIGHTING AND LIGHT SIGNALLING DEVICES

10.1. Table of all devices: number, make, model, type-approval mark, maximum intensity of main-beam headlamps, colour, tell-tale: ...

10.2. Drawing of the position of lighting and light signalling devices: ...

10.3. For every lamp and reflector specified in Council Directive 76/756/EEC ([OJ L 262, 27.9.1976, p. 1](#)) supply the following information (in writing and/or by diagram)

10.3.1. Drawing showing the extent of the illuminating surface: ...

10.3.2. Method used for the definition of the apparent surface in accordance with paragraph 2.10 of UNECE Regulation No 48 ([OJ L 137, 30.5.2007, p. 1](#)): ...

10.3.3. Axis of reference and centre of reference: ...

10.3.4. Method of operation of concealable lamps: ...

10.3.5. Any specific mounting and wiring provisions: ...

---

**Status:** EU Directives are being published on this site to aid cross referencing from UK legislation. After IP completion day (31 December 2020 11pm) no further amendments will be applied to this version.

---

10.4. Dipped beam lamps: normal orientation in accordance to paragraph 6.2.6.1 of UNECE Regulation No 48:

10.4.1. Value of initial adjustment: ...

10.4.2. Location of indication: ...

10.4.3.	Description/drawing <sup>a</sup> and type of headlamp levelling device (e.g. automatic, stepwise manually adjustable, continuously manually adjustable):	Applicable only for vehicles with headlamp levelling device
10.4.4.	Control device:	
10.4.5.	Reference marks:	
10.4.6.	Marks assigned for loading conditions:	

<sup>a</sup> Delete where not applicable (there are cases where nothing needs to be deleted when more than one entry is applicable).

10.5. A brief description of electrical/electronic components other than lamps (if any): ...

11. CONNECTIONS BETWEEN TOWING VEHICLES AND TRAILERS AND SEMI-TRAILERS

11.1. Class and type of the coupling device(s) fitted or to be fitted: ...

11.2. Characteristics D, U, S and V of the coupling device(s) fitted or minimal characteristics D, U, S and V of the coupling device(s) to be fitted: ..... daN

11.3. Instructions for attachment of the coupling type to the vehicle and photographs or drawings of the fixing points at the vehicle as stated by the manufacturer; additional information, if the use of the coupling type is restricted to certain variants or versions of the vehicle type: ...

11.4. Information of the fitting of special towing brackets or mounting plates: ...

11.5. Type-approval number(s): ...

12. MISCELLANEOUS

12.1. Audible warning device(s)

12.1.1. Location, method of affixing, placement and orientation of the device(s), with dimensions: ...

12.1.2. Number of device(s): ...

12.1.3. Type-approval number(s): ...

12.1.4. Electrical/pneumatic<sup>(19)</sup> circuit diagram: ...

12.1.5. Rated voltage or pressure: ...

12.1.6. Drawing of the mounting device: ...

---

*Status: EU Directives are being published on this site to aid cross referencing from UK legislation. After IP completion day (31 December 2020 11pm) no further amendments will be applied to this version.*

---

- 12.2. Devices to prevent unauthorised use of the vehicle
  - 12.2.1. Protective device
    - 12.2.1.1. A detailed description of the vehicle type with regard to the arrangement and design of the control or of the unit on which the protective device acts: ...
    - 12.2.1.2. Drawings of the protective device and of its mounting on the vehicle: ...
    - 12.2.1.3. A technical description of the device: ...
    - 12.2.1.4. Details of the lock combinations used: ...
    - 12.2.1.5. Vehicle immobiliser
      - 12.2.1.5.1 Type-approval number, if available: ...
      - 12.2.1.5.2 For immobilisers not yet approved
      - 12.2.1.5.2A detailed technical description of the vehicle immobiliser and of the measures taken against inadvertent activation: ...
      - 12.2.1.5.2B The system(s) on which the vehicle immobiliser acts: ...
      - 12.2.1.5.2C Number of effective interchangeable codes, if applicable: ...
  - 12.2.2. Alarm system (if any)
    - 12.2.2.1. Type-approval number, if available: ...
    - 12.2.2.2. For alarm systems not yet approved
      - 12.2.2.2.1A detailed description of the alarm system and of the vehicle parts related to the alarm system installed: ...
      - 12.2.2.2.2A list of the main components comprising the alarm system: ...
  - 12.2.3. A brief description of the electrical/electronic components (if any): ...
- 12.3. Towing device(s)
  - 12.3.1. Front: Hook/eye/other<sup>(19)</sup>
  - 12.3.2. Rear: Hook/eye/other/none<sup>(19)</sup>
  - 12.3.3. Drawing or photograph of the chassis/area of the vehicle body showing the position, construction and mounting of the towing device(s): ...
- 12.4. Details of any non-engine related devices designed to influence fuel consumption (if not covered by other items): ...
- 12.5. Details of any non-engine related devices designed to reduce noise (if not covered by other items): ...
- 12.6. Speed limitation devices
  - 12.6.1. Manufacturer(s): ...
  - 12.6.2. Type(s): ...
  - 12.6.3. Type-approval number(s), if available: ...



**Status:** EU Directives are being published on this site to aid cross referencing from UK legislation. After IP completion day (31 December 2020 11pm) no further amendments will be applied to this version.

12.6.4. Speed or range of speeds at which the speed limitation may be set: ..... km/h

12.7. Table of installation and use of RF transmitters in the vehicle(s), if applicable: ...

Frequency bands (Hz)	Maximum output power (W)	Antenna position at vehicle, specific conditions for installation and/or use

The applicant for type-approval shall also supply, where appropriate:

*Appendix 1*

A list containing make and type of all electrical and/or electronic components concerned by Commission Directive 72/245/EEC (OJ L 152, 6.7.1972, p. 15).

*Appendix 2*

Schematics or drawing of the general arrangement of electrical and/or electronic components concerned by Directive 72/245/EEC and the general wiring harness arrangement.

*Appendix 3*

Description of vehicle chosen to represent the type

Body style:

Left- or right-hand drive<sup>(19)</sup>

Wheelbase:

*Appendix 4*

Relevant test report(s) supplied by the manufacturer or approved/recognised laboratories for the purpose of drawing up the type-approval certificate

12.7.1. Vehicle equipped with a 24 GHz short-range radar equipment: yes/no<sup>(19)</sup>

13. SPECIAL PROVISIONS FOR BUSES AND COACHES

13.1. Class of vehicle: Class I/Class II/Class III/Class A/Class B<sup>(19)</sup>

13.1.1. Type-approval number of bodywork approved as a separate technical unit: ...

13.1.2. Chassis types where the type-approved bodywork can be installed (manufacturer(s), and types of incomplete vehicle): ...

13.2. Area for passengers (m<sup>2</sup>)

13.2.1. Total (S<sub>0</sub>): ...

13.2.2. Upper deck (S<sub>0a</sub>)<sup>(19)</sup>: ...

13.2.3. Lower deck (S<sub>0b</sub>)<sup>(19)</sup>: ...

13.2.4. For standing passengers (S<sub>1</sub>): ...

13.3. Number of passengers (seated and standing)

13.3.1. Total (N): ...

---

*Status: EU Directives are being published on this site to aid cross referencing from UK legislation. After IP completion day (31 December 2020 11pm) no further amendments will be applied to this version.*

---

- 13.3.2. Upper deck ( $N_a$ )<sup>(19)</sup>: ...
- 13.3.3. Lower deck ( $N_b$ )<sup>(19)</sup>: ...
- 13.4. Number of passengers seated
  - 13.4.1. Total (A): ...
  - 13.4.2. Upper deck ( $A_a$ )<sup>(19)</sup>: ...
  - 13.4.3. Lower deck ( $A_b$ )<sup>(19)</sup>: ...
  - 13.4.4. Number of wheelchair positions for category M<sub>2</sub> and M<sub>3</sub> vehicles: ...
- 13.5. **Number of service doors**: ...
- 13.6. **Number of emergency exits** (doors, windows, escape hatches, intercommunication staircase and half staircase): ...
  - 13.6.1. Total: ...
  - 13.6.2. Upper deck<sup>(19)</sup>: ...
  - 13.6.3. Lower deck<sup>(19)</sup>: ...
- 13.7. **Volume of luggage compartments (m<sup>3</sup>)**: ...
- 13.8. **Area of luggage transportation on the roof (m<sup>2</sup>)**: ...
- 13.9. **Technical devices facilitating the access to vehicles** (e.g. ramp, lifting platform, kneeling system), if fitted: ...
- 13.10. Strength of superstructure
  - 13.10.1. Type-approval number, if available: ...
  - 13.10.2. For superstructures not yet approved
    - 13.10.2.1 Detailed description of the superstructure of the vehicle type including its dimensions, configuration and constituent materials and its attachment to any chassis frame: ...
    - 13.10.2.2 Drawings of the vehicle and those parts of its interior arrangement which have an influence on the strength of the superstructure or on the residual space: ...
    - 13.10.2.3 Position of centre of gravity of the vehicle in running order in the longitudinal, transverse and vertical directions: ...
    - 13.10.2.4 Maximum distance between the centre lines of the outboard passenger seats: ...
- 13.11. **Points of Directive 2001/85/EC of the European parliament and of the Council (OJ L 42, 13.2.2002, p. 1) to be accomplished and demonstrated for this technical unit**: ...
- [<sup>F4</sup>13.12. **Drawing with dimensions showing the interior arrangement as regards the seating positions, area for standees, wheelchair user(s), luggage compartments including racks and ski-box, if any**]

14. SPECIAL PROVISIONS FOR VEHICLES INTENDED FOR THE TRANSPORT OF DANGEROUS GOODS
  - 14.1. Electrical equipment according to Council Directive 94/55/EC (OJ L 319, 12.12.1994, p. 1)
    - 14.1.1. Protection against overheating of conductors: ...
    - 14.1.2. Type of circuit breaker: ...
    - 14.1.3. Type and operation of battery master switch: ...
    - 14.1.4. Description and location of safety barrier for tachograph: ...
    - 14.1.5. Description of permanently energised installations. Indicate the EN standard applied: ...
    - 14.1.6. Construction and protection of electrical installation situated to the rear of the driver's compartment: ...
  - 14.2. Prevention of fire risks
    - 14.2.1. Type of not readily flammable material in the driver's compartment: ...
    - 14.2.2. Type of heat shield behind the driver's compartment (if applicable): ...
    - 14.2.3. Position and heat protection of engine: ...
    - 14.2.4. Position and heat protection of the exhaust system: ...
    - 14.2.5. Type and design of the endurance braking systems heat protection: ...
    - 14.2.6. Type, design and position of combustion heaters: ...
  - 14.3. Special requirements for bodywork, if any, according to Directive 94/55/EC
    - 14.3.1. Description of measures to comply with the requirements for Type EX/II and Type EX/III vehicles: ...
    - 14.3.2. In the case of Type EX/III vehicles, resistance against heat from the outside: ...
15. REUSABILITY, RECYCLABILITY AND RECOVERABILITY
  - 15.1. Version to which the reference vehicle belongs: ...
  - 15.2. Mass of the reference vehicle with bodywork or mass of the chassis with cab, without bodywork and/or coupling device if the manufacturer does not fit the bodywork and/or coupling device (including liquids, tools, spare wheel, if fitted) without driver: ...
  - 15.3. Mass of materials of the reference vehicle: ...
    - 15.3.1. Mass of material taken into account at the pre-treatment step<sup>(63)</sup>: ...
    - 15.3.2. Mass of the material taken into account at the dismantling step<sup>(63)</sup>: ...
    - 15.3.3. Mass of material taken into account at the non-metallic residue treatment step, considered as recyclable<sup>(63)</sup>: ...
    - 15.3.4. Mass of material taken into account at the non-metallic residue treatment step, considered as energy recoverable<sup>(63)</sup>: ...

---

*Status: EU Directives are being published on this site to aid cross referencing from UK legislation. After IP completion day (31 December 2020 11pm) no further amendments will be applied to this version.*

---

- 15.3.5. Materials breakdown<sup>(63)</sup>: ...
  - 15.3.6. Total mass of materials, which are reusable and/or recyclable: ...
  - 15.3.7. Total mass of materials, which are reusable and/or recoverable: ...
  - 15.4. Rates
    - 15.4.1. Recyclability rate 'R<sub>cyc</sub>' (%): ...
    - 15.4.2. Recoverability rate 'R<sub>cov</sub>' (%): ...
  - 16. ACCESS TO VEHICLE REPAIR AND MAINTENANCE INFORMATION
    - 16.1. Address of principal website for access to vehicle repair and maintenance information: ...
      - 16.1.1. Date from which it is available (no later than 6 months from the date of type-approval): ...
    - 16.2. Terms and conditions of access to website: ...
    - 16.3. Format of the vehicle repair and maintenance information accessible through website: ...
- Explanatory notes
- (<sup>5</sup>) Set out in such a way as to make the actual value clear for each technical configuration of the vehicle type.
  - [<sup>F7(x)</sup> Dual-fuel engines.]]

## [<sup>F16</sup>ANNEX II

### GENERAL DEFINITIONS, CRITERIA FOR VEHICLE CATEGORISATION, VEHICLE TYPES AND TYPES OF BODYWORK

#### Textual Amendments

**F16** Substituted by Commission Regulation (EU) No 678/2011 of 14 July 2011 replacing Annex II and amending Annexes IV, IX and XI to Directive 2007/46/EC of the European Parliament and of the Council establishing a framework for the approval of motor vehicles and their trailers, and of systems, components and separate technical units intended for such vehicles (Framework Directive) (Text with EEA relevance).

#### INTRODUCTORY PART **General definitions and general provisions**

- 1. **Definitions**
  - 1.1. '*Seating position*' means any location capable of accommodating one person seated who is at least as large as:
    - (a) the manikin of the 50th percentile male in the case of the driver;
    - (b) the manikin of the 5th percentile adult female in all other cases.

1.2. 'Seat' means a complete structure with trim, integral or not with the vehicle body structure, which is intended to seat one person.

1.2.1. The term 'seat' covers both an individual seat and a bench seat.

1.2.2. Folding seats and removable seats are included in this definition.

1.3. 'Goods' means primarily any movable things.

The term 'goods' includes products in bulk, manufactured goods, liquids, living animals, crops, indivisible loads.

1.4. 'Maximum mass' means the 'technically permissible maximum laden mass' as specified in point 2.8 of Annex I.

## 2. General provisions

2.1. Number of seating positions

2.1.1. The requirements regarding the number of seating positions apply to seats that are designed for use when the vehicle is travelling on the road.

2.1.2. They do not apply to seats that are designed for use when the vehicle is stationary and which are clearly identified to users either by means of a pictogram or a sign with an appropriate text.

2.1.3. The following requirements apply for the counting of the seating positions:

(a) each individual seat shall be counted as one seating position;

(b) in the case of a bench seat, any space having a width of at least 400 mm measured at the seat cushion level shall be counted as one seating position.

This condition shall not prevent the manufacturer from using the general provisions referred to in point 1.1;

(c) however, a space as referred to in point (b) shall not be counted as one seating position where:

(i) the bench seat includes features that prevent the bottom of the manikin from sitting in a natural way - for example: the presence of a fixed console box, an unpadded area or an interior trim interrupting the nominal seating surface;

(ii) the design of the floor pan located immediately in front of a presumed seating position (for example the presence of a tunnel) prevents the feet of the manikin from being positioned in a natural way.

2.1.4. With respect to vehicles covered by Directive 2001/85/EC of the European Parliament and of the Council of 20 November 2001 relating to special provisions for vehicles used for the carriage of passengers comprising more than eight seats in addition to the driver's seat, and amending Directives 70/156/EEC and 97/27/EC<sup>(64)</sup>, the dimension referred to in point 2.1.3(b) shall be aligned with the minimum space required for one person in relation to the various classes of vehicles.

2.1.5. When seat anchors for a removable seat are present in a vehicle, the removable seat shall be counted in the determination of the number of the seating positions.

2.1.6. An area intended for an occupied wheelchair shall be regarded as one seating position.

---

*Status: EU Directives are being published on this site to aid cross referencing from UK legislation. After IP completion day (31 December 2020 11pm) no further amendments will be applied to this version.*

---

- 2.1.6.1. This provision shall be without prejudice to the requirements of point 3.6.1 and point 3.7 of Annex VII to Directive 2001/85/EC.
- 2.2. Maximum mass
  - 2.2.1. In the case of a tractor unit for semi-trailer, the maximum mass to be considered for classifying the vehicle shall include the maximum mass of the semi-trailer borne by the fifth wheel coupling.
  - 2.2.2. In the case of a motor vehicle that can tow a centre-axle trailer or a rigid drawbar trailer, the maximum mass to be considered for classifying the motor vehicle shall include the maximum mass transferred to the towing vehicle by the coupling.
  - 2.2.3. In the case of a semi-trailer, a centre-axle trailer and a rigid drawbar trailer, the maximum mass to be considered for classifying the vehicle shall correspond to the maximum mass transmitted to the ground by the wheels of an axle or group of axles when coupled to the towing vehicle.
  - 2.2.4. In the case of a converter dolly, the maximum mass to be considered for classifying the vehicle shall include the maximum mass of the semi-trailer borne by the fifth wheel coupling.
- 2.3. Special equipment
  - 2.3.1. Vehicles fitted primarily with fixed equipment such as machinery or apparatus shall be regarded as N or O category.
- 2.4. Units
  - 2.4.1. Unless otherwise stated any unit of measurement and associated symbol shall conform to the provisions of Council Directive 80/181/EEC<sup>(65)</sup>.
- 3. **Categorisation into vehicle categories**
  - 3.1. The manufacturer is responsible for the categorisation of a type of vehicle into a specific category.

For such purposes, all the relevant criteria described in this Annex shall be met.

- 3.2. The approval authority may request from the manufacturer appropriate additional information with the aim of demonstrating that a vehicle type needs to be categorised as special purpose vehicle in the special group ('SG Code').

## PART A

### Criteria for vehicle categorisation

#### 1. Vehicle categories

For the purposes of European and national type-approval, as well as individual approval, vehicles shall be categorised according to the following classification:

(It is understood that approval can only be granted for the categories referred to in points 1.1.1 to 1.1.3, 1.2.1 to 1.2.3 and 1.3.1 to 1.3.4.)

- 1.1. Category M                      Motor vehicles designed and constructed primarily for the carriage of persons and their luggage.

- 1.1.1. Category M<sub>1</sub> Vehicles of category M, comprising not more than eight seating positions in addition to the driver's seating position.
- Vehicles belonging to category M<sub>1</sub> shall have no space for standing passengers.
- The number of seating positions may be restricted to one (i.e. the driver's seating position).
- 1.1.2. Category M<sub>2</sub> Vehicles of category M, comprising more than eight seating positions in addition to the driver's seating position and having a maximum mass not exceeding 5 tonnes.
- Vehicles belonging to category M<sub>2</sub> may have space for standing passengers in addition to the seating positions.
- 1.1.3. Category M<sub>3</sub> Vehicles of category M, comprising more than eight seating positions in addition to the driver's seating position and having a maximum mass exceeding 5 tonnes.
- Vehicles belonging to category M<sub>3</sub> may have space for standing passengers.
- 1.2. Category N Motor vehicles designed and constructed primarily for the carriage of goods.
- 1.2.1. Category N<sub>1</sub> Vehicles of category N having a maximum mass not exceeding 3,5 tonnes.
- 1.2.2. Category N<sub>2</sub> Vehicles of category N having a maximum mass exceeding 3,5 tonnes but not exceeding 12 tonnes.
- 1.2.3. Category N<sub>3</sub> Vehicles of category N having a maximum mass exceeding 12 tonnes.
- 1.3. Category O Trailers designed and constructed for the carriage of goods or of persons as well as for the accommodation of persons.
- 1.3.1. Category O<sub>1</sub> Vehicles of category O having a maximum mass not exceeding 0,75 tonnes
- 1.3.2. Category O<sub>2</sub> Vehicles of category O having a maximum mass exceeding 0,75 tonnes but not exceeding 3,5 tonnes.
- 1.3.3. Category O<sub>3</sub> Vehicles of category O having a maximum mass exceeding 3,5 tonnes but not exceeding 10 tonnes.
- 1.3.4. Category O<sub>4</sub> Vehicles of category O having a maximum mass exceeding 10 tonnes.

## 2. Vehicle subcategories

### 2.1. Off-road vehicles

'*Off-road vehicle (ORV)*' means a vehicle that belongs either to category M or N, having specific technical features which permit its use off the normal roads.

For those categories of vehicles, the letter 'G' shall be added as suffix to the letter and numeral identifying the vehicle category.

The criteria for the subcategorisation of vehicles as 'ORV' shall be specified in Section 4 of Part A of this Annex.

### 2.2. Special purpose vehicles

- 2.2.1. '*Special purpose vehicle (SPV)*' means a vehicle of category M, N or O having specific technical features in order to perform a function which requires special arrangements and/or equipment.

---

*Status: EU Directives are being published on this site to aid cross referencing from UK legislation. After IP completion day (31 December 2020 11pm) no further amendments will be applied to this version.*

---

For incomplete vehicles that are intended to fall into the SPV subcategory, the letter ‘S’ shall be added as suffix to the letter and numeral identifying the vehicle category.

The various types of special purpose vehicles are defined and listed in Section 5.

2.3. Off road special purpose vehicle

2.3.1. ‘Off road special purpose vehicle (ORV-SPV)’ means a vehicle that belongs either to category M or N having the specific technical features referred to in points 2.1 and 2.2.

For those categories of vehicles, the letter ‘G’ shall be added as suffix to the letter and numeral identifying the vehicle category.

Moreover, for incomplete vehicles that are intended to fall into the SPV subcategory, the letter ‘S’ shall be added as second suffix.

3. **Criteria for the categorisation of vehicles in category N**

3.1. The categorisation of a vehicle type in category N shall be based on the technical features of the vehicle as referred to in points 3.2 to 3.6.

3.2. As a matter of principle, the compartment(s) where all the seating positions are located shall be completely separated from the loading area.

3.3. By way of derogation from the requirements of point 3.2, persons and goods may be transported in the same compartment under the condition that the loading area is provided with securing devices designed to protect persons transported against the displacement of the load during driving, including severe braking and cornering.

3.4. Securing devices - lashing devices - intended for securing the load as required in point 3.3 as well as partitioning systems, intended for vehicles up to 7,5 tonnes shall be designed in accordance with the provisions of Sections 3 and 4 of Standard ISO 27956:2009 ‘Road vehicles – Securing of cargo in delivery vans – Requirements and test methods’.

3.4.1. The requirements referred to in point 3.4 may be verified by a statement of compliance provided by the manufacturer.

3.4.2. As an alternative to the requirements of point 3.4, the manufacturer may demonstrate to the satisfaction of the approval authority that the securing devices fitted show an equivalent level of protection as provided in the referred standard.

3.5. The number of seating positions excluding the driver’s seating position shall not exceed:

- (a) 6 in the case of N<sub>1</sub> vehicles;
- (b) 8 in the case of N<sub>2</sub> or N<sub>3</sub> vehicles.

3.6. Vehicles shall show a goods-carrying capacity equal or higher than the person-carrying capacity expressed in kg.

3.6.1. For such purposes, the following equations shall be satisfied in all configurations, in particular when all seating positions are occupied:

- (a) when N = 0:

$$P - M \geq 100 \text{ kg}$$



(b) when  $0 < N \leq 2$ :  
 $P - (M + N \times 68) \geq 150 \text{ kg}$ ;

(c) when  $N > 2$ :  
 $P - (M + N \times 68) \geq N \times 68$ ;

where the letters have the following meaning:

‘P’ is the technically permissible maximum laden mass;  
‘M’ is the mass in running order;  
‘N’ is the number of seating positions excluding the driver’s seating position.

3.6.2. The mass of equipment that is fitted to the vehicle in order to accommodate goods (e.g. tank, bodywork, etc.), to handle goods (e.g. crane, lift, etc.) and to secure goods (e.g. cargo securing devices) shall be included in M.

The mass of equipment that is not used for the purposes referred to above (such as a compressor, a winch, an electric power generator, broadcasting equipment, etc.) shall not be included in M for the purposes of the application of the above formulae.

3.7. The requirements referred to in points 3.2 to 3.6 shall be met for all variants and versions within the vehicle type.

3.8. Criteria for the categorisation of vehicles as  $N_1$ .

3.8.1. A vehicle shall be categorised as  $N_1$  when all the applicable criteria are met.

When one or more of the criteria are not met, the vehicle shall be categorised as  $M_1$ .

3.8.2. In addition to the general criteria referred to in points 3.2 to 3.6, the criteria specified in points 3.8.2.1 to 3.8.2.3.5 shall be met for the categorisation of vehicles for which the compartment where the driver is located and the load are within a single unit (i.e. bodywork ‘BB’).

3.8.2.1. The fact that a wall or a partition, complete or partial, is fitted between a seat row and the cargo area shall not rule out the obligation to meet the required criteria.

3.8.2.2. The criteria shall be as follows:

(a) the loading of the goods shall be possible by a rear door, a tailgate or a side-door designed and constructed for that purposes;

(b) in the case of a rear door or a tailgate, the loading aperture shall meet the following requirements:

(i) in the case the vehicle is fitted with only one row of seats or with only the driver seat, the minimum height of the loading aperture shall be at least 600 mm;

(ii) in the case the vehicle is fitted with two or more rows of seats, the minimum height of the loading aperture shall be at least 800 mm and the aperture shall show a surface of at least 12 800 cm<sup>2</sup>;

(c) The cargo area shall meet the following requirements:

---

*Status: EU Directives are being published on this site to aid cross referencing from UK legislation. After IP completion day (31 December 2020 11pm) no further amendments will be applied to this version.*

---

‘*cargo area*’ means the part of the vehicle located behind the row(s) of seats or behind the driver seat when the vehicle is fitted with only one driver seat;

- (i) the loading surface of the cargo area shall be generally flat;
- (ii) where the vehicle is fitted with only one row of seats or with one seat, the minimum length of the cargo area shall be at least 40 % of the wheelbase;
- (iii) where the vehicle is fitted with two or more rows of seats, the minimum length of the cargo area shall be at least 30 % of the wheelbase.

Where the seats of the last row of seats can be easily removed from the vehicle without the use of special tools, the requirements regarding the length of the cargo area shall be met with all the seats installed in the vehicle;

- (iv) the requirements regarding the length of the cargo area shall be met when the seats of the first row or of the last row, as the case may be, are upright in their normal position for use by the vehicle occupants.

### 3.8.2.3. Specific conditions for measurement

#### 3.8.2.3.1. Definitions

- (a) ‘*Height of the loading aperture*’, means the vertical distance between two horizontal planes tangent respectively to the highest point of the lower part of the doorway and the lowest point of the upper part of the doorway;
- (b) ‘*surface of the loading aperture*’ means the greatest surface of the orthogonal projection on a vertical plane, perpendicular to the centreline of the vehicle, of the maximum aperture permitted when the rear door(s) or tailgate is (are) wide open;
- (c) ‘*wheelbase*’, for the purposes of application of the formulae in points 3.8.2.2 and 3.8.3.1, means the distance between:
  - (i) the centreline of the front axle and the centreline of the second axle in the case of a two axle vehicle; or
  - (ii) the centreline of the front axle and the centreline of a virtual axle equally distant from the second and third axle in the case of a three axle vehicle.

#### 3.8.2.3.2. Seat adjustments

- (a) the seats shall be adjusted at their rear outermost positions;
- (b) the seat back, if adjustable, shall be adjusted as to accommodate the three-dimensional H-point machine at a torso angle of 25 degrees;
- (c) the seat back, if not adjustable, shall be in the position designed by the vehicle manufacturer;
- (d) When the seat is adjustable in height, it shall be adjusted to its lowest position.

#### 3.8.2.3.3. Vehicle conditions

- (a) the vehicle shall be in loaded conditions corresponding to its maximum mass;
- (b) the vehicle shall be with its wheels straight ahead.

3.8.2.3.4. The requirements of point 3.8.2.3.2 shall not apply when the vehicle is fitted with a wall or a partition.

3.8.2.3.5. Measurement of the length of the cargo area

- (a) When the vehicle is not fitted with a partition or a wall, the length shall be measured from a vertical plane tangent to the rear outermost point of the top of the seat back to the rear internal pane or door or tailgate, in closed position;
- (b) when the vehicle is fitted with a partition or a wall, the length shall be measured from a vertical plane tangent to the rear outermost point of the partition or the wall to the rear internal pane or door or tailgate, as the case may be, in closed position;
- (c) the requirements concerning the length shall be fulfilled at least along an horizontal line situated in the longitudinal vertical plane passing through the centreline of the vehicle, at the level of the load floor.

3.8.3. In addition to the general criteria referred to in points 3.2 to 3.6, the criteria specified in points 3.8.3.1 to 3.8.3.4 shall be met for the categorisation of vehicles for which the compartment where the driver is located and the load are not within a single unit (i.e. bodywork 'BE').

3.8.3.1. Where the vehicle is fitted with an enclosure type body, the following shall apply:

- (a) the loading of the goods shall be possible by a rear door, a tailgate or a panel or other means;
- (b) the minimum height of the loading aperture shall be at least 800 mm and the aperture shall show a surface of at least 12 800 cm<sup>2</sup>;
- (c) The minimum length of the cargo area shall be at least 40 % of the wheelbase.

3.8.3.2. Where the vehicle is fitted with an open type cargo area, only the provisions referred to in points 3.8.3.1(a) and (c) shall apply.

3.8.3.3. For the application of the provisions referred to in point 3.8.3, the definitions in point 3.8.2 shall apply *mutatis mutandis*.

3.8.3.4. However, the requirements concerning the length of the cargo area shall be fulfilled along a horizontal line situated in the longitudinal plane passing through the centreline of the vehicle at the level of the load floor.

#### 4. **Criteria for the subcategorisation of vehicles as off-road vehicles**

4.1. M<sub>1</sub> or N<sub>1</sub> vehicles shall be subcategorised as off-road vehicles if they satisfy at the same time the following conditions:

- (a) at least one front and at least one rear axle designed to be driven simultaneously irrespective of whether one powered axle can be disengaged;
- (b) at least one differential locking mechanism or a mechanism having similar effect is fitted;
- (c) they are able to climb at least a 25 % gradient as solo vehicle;
- (d) they satisfy five out of the following six requirements:
  - (i) the approach angle shall be at least 25 degrees;

---

*Status: EU Directives are being published on this site to aid cross referencing from UK legislation. After IP completion day (31 December 2020 11pm) no further amendments will be applied to this version.*

---

- (ii) the departure angle shall be at least 20 degrees;
  - (iii) the ramp angle shall be at least 20 degrees;
  - (iv) the ground clearance under the front axle shall be at least 180 mm;
  - (v) the ground clearance under the rear axle shall be at least 180 mm;
  - (vi) the ground clearance between the axles shall be at least 200 mm.
- 4.2. M<sub>2</sub>, N<sub>2</sub> or M<sub>3</sub> vehicles whose maximum mass does not exceed 12 tonnes shall be subcategorised as off-road vehicles if they satisfy the condition set out in point (a) or both conditions set out in points (b) and (c):
- (a) all their axles are driven simultaneously, irrespective of whether one or more powered axles can be disengaged;
  - (b)
    - (i) at least one front and at least one rear axle are designed to be driven simultaneously irrespective of whether one powered axle can be disengaged;
    - (ii) at least one differential locking mechanism or a mechanism having the same effect is fitted;
    - (iii) they are able to climb a 25 % gradient as a solo vehicle;
  - (c) they satisfy at least five out of the following six requirements if their maximum mass does not exceed 7,5 tonnes and at least four if their maximum mass exceeds 7,5 tonnes:
    - (i) the approach angle shall be at least 25 degrees;
    - (ii) the departure angle shall be at least 25 degrees;
    - (iii) the ramp angle shall be at least 25 degrees;
    - (iv) the ground clearance under the front axle shall be at least 250 mm;
    - (v) the ground clearance between axles shall be at least 300 mm;
    - (vi) the ground clearance under the rear axle shall be at least 250 mm.
- 4.3. M<sub>3</sub> or N<sub>3</sub> vehicles whose maximum mass exceeds 12 tonnes shall be subcategorised as off-road vehicles if they satisfy the condition set out in point (a) or both conditions set out in points (b) and (c):
- (a) all their axles are driven simultaneously, irrespective of whether one or more powered axles can be disengaged;
  - (b)
    - (i) at least half of the axles (or two axles out of the three in the case of a three axle vehicle and *mutatis mutandis* in the case of a five axle vehicle) is designed to be driven simultaneously, irrespective of whether one powered axle can be disengaged;
    - (ii) there is at least one differential locking mechanism or a mechanism having similar effect;
    - (iii) they are able to climb a 25 % gradient as solo vehicle;
  - (c) they satisfy at least four out of the following six requirements:
    - (i) the approach angle shall be at least 25 degrees;

*Status: EU Directives are being published on this site to aid cross referencing from UK legislation. After IP completion day (31 December 2020 11pm) no further amendments will be applied to this version.*

- (ii) the departure angle shall be at least 25 degrees;
- (iii) the ramp angle shall be at least 25 degrees;
- (iv) the ground clearance under the front axle shall be at least 250 mm;
- (v) the ground clearance between axles shall be at least 300 mm;
- (vi) the ground clearance under the rear axle shall be at least 250 mm.

4.4. The procedure for checking compliance with the geometrical provisions referred to in this section shall be set out in Appendix 1.

## 5. Special purpose vehicles

	Name	Code	Definition
5.1.	Motor caravan	SA	<p>A vehicle of category M with living accommodation space which contains the following equipment as a minimum:</p> <ul style="list-style-type: none"> <li>(a) seats and table;</li> <li>(b) sleeping accommodation which may be converted from the seats;</li> <li>(c) cooking facilities;</li> <li>(d) storage facilities.</li> </ul> <p>This equipment shall be rigidly fixed to the living compartment. However, the table may be designed to be easily removable.</p>
5.2.	Armoured vehicle	SB	a vehicle intended for the protection of conveyed persons or goods with anti-bullet armour plating.
[ <sup>F17</sup> 5.3.	Ambulance	SC	a vehicle of category M intended for the transport of sick or injured persons and having special

*Status: EU Directives are being published on this site to aid cross referencing from UK legislation. After IP completion day (31 December 2020 11pm) no further amendments will be applied to this version.*

			equipment for such purpose.]
5.4.	Hearse	SD	a vehicle of category M intended for the transport of deceased persons and having special equipment for such purpose.
5.5.	Wheelchair accessible vehicle	SH	a vehicle of category M <sub>1</sub> constructed or converted specifically so that they accommodate one or more persons seated in their wheelchairs when travelling on the road.
5.6.	Trailer caravan	SE	a vehicle of category O as defined in term 3.2.1.3 of Standard ISO 3833:1977.
5.7.	Mobile crane	SF	a vehicle of category N <sub>3</sub> , not fitted for the carriage of goods, provided with a crane whose lifting moment is equal to or higher than 400 kNm.
5.8.	Special group	SG	a special purpose vehicle which does not enter in any of the definitions mentioned in this section.
5.9.	Converter dolly	SJ	a vehicle of category O equipped with a fifth-wheel coupling to support a semi-trailer with a view to converting the latter into a trailer.
5.10.	Exceptional load transport trailer	SK	a vehicle of category O <sub>4</sub> intended for the transport of indivisible loads that is subject to speed and traffic restrictions because of its dimensions.

**Status:** EU Directives are being published on this site to aid cross referencing from UK legislation. After IP completion day (31 December 2020 11pm) no further amendments will be applied to this version.

			Under this term are also included hydraulic modular trailers irrespective of the number of modules.
[ <sup>F18</sup> 5.11.	Exceptional load transport motor vehicle	SL	<p>a road tractor or tractor unit for semi-trailer of category N<sub>3</sub> meeting all the following conditions:</p> <p>(a) having more than two axles and at least half of the axles (two axles out of three in the case of a three axle vehicle and <i>mutatis mutandis</i> in the case of a five axle vehicle) designed to be driven simultaneously, irrespective of whether one powered axle can be disengaged,</p> <p>(b) which is designed for towing and pushing exceptional load transport trailer of category O<sub>4</sub>,</p> <p>(c) which has a minimum engine power of 350 kW, and</p> <p>(d) which can be equipped with an</p>

*Status: EU Directives are being published on this site to aid cross referencing from UK legislation. After IP completion day (31 December 2020 11pm) no further amendments will be applied to this version.*

			additional front coupling device for heavy towable masses
5.12.	Multi-equipment carrier	SM	<p>an off-road vehicle of category N (as defined in point 2.3) designed and constructed for pulling, pushing, carrying and actuating certain inter-changeable equipment,</p> <p>(a) with not less than two mounting areas for this equipment,</p> <p>(b) with standardised, mechanical, hydraulic and/or electrical interfaces (e.g. Power take off) for powering and actuating the above mentioned equipment and</p> <p>(c) which fulfills the definition of ISO 3833-1977, section 3.1.4 (special vehicle).</p> <p>If the vehicle is equipped with an auxiliary load platform, its</p>



			<p>maximum length shall not exceed:</p> <p>(a) 1,4 times of the front or rear track width of the vehicle, whichever is the larger in the case of two axle vehicles, or</p> <p>(b) 2,0 times of the front or rear track width of the vehicle, whichever is the larger in the case of vehicles having more than two axles]</p>
--	--	--	--

#### Textual Amendments

- F17** Substituted by Commission Regulation (EU) No 214/2014 of 25 February 2014 amending Annexes II, IV, XI, XII and XVIII to Directive 2007/46/EC of the European Parliament and of the Council establishing a framework for the approval of motor vehicles and their trailers, and of systems, components and separate technical units intended for such vehicles (Text with EEA relevance).
- F18** Inserted by Commission Regulation (EU) No 214/2014 of 25 February 2014 amending Annexes II, IV, XI, XII and XVIII to Directive 2007/46/EC of the European Parliament and of the Council establishing a framework for the approval of motor vehicles and their trailers, and of systems, components and separate technical units intended for such vehicles (Text with EEA relevance).

#### 6. Remarks

- 6.1. Type-approval shall not be granted:
- (a) to converter dolly as defined in Section 5 of Part A of this Annex;
- (b) to rigid drawbar trailers as defined in Section 4 of Part C of this Annex;
- (c) to trailers in which persons may be carried when travelling on the road.
- 6.2. Paragraph 6.1 is without prejudice to the provisions of Article 23 on national small series type-approval.

---

*Status: EU Directives are being published on this site to aid cross referencing from UK legislation. After IP completion day (31 December 2020 11pm) no further amendments will be applied to this version.*

---

## PART B

### Criteria for vehicle types, variants and versions

#### 1. Category M<sub>1</sub>

##### 1.1. Vehicle type

1.1.1. A 'vehicle type' shall consist of vehicles which have all of the following features in common:

(a) the manufacturer's company name.

A change in the legal form of ownership of the company does not require that a new approval has to be granted;

(b) the design and assembly of the essential parts of the body structure in the case of a self-supporting body.

The same shall apply *mutatis mutandis* to vehicles the bodywork of which is bolted on or welded to a separate frame;

(c) in the case of multi-stage built vehicles, the manufacturer and the type of the previous stage vehicle.

1.1.2. By way of derogation from the requirements of point 1.1.1(b), when the manufacturer uses the floor portion of the body structure as well as the essential constituent elements forming the front part of the body structure located directly in front of the windscreen bay, in the construction of different kinds of bodywork (for example a saloon and a coupe), those vehicles may be considered as belonging to the same type. Evidence thereof shall be provided by the manufacturer.

1.1.3. A type shall consist of at least one variant and one version.

##### 1.2. Variant

1.2.1. A 'variant' within a vehicle type shall group the vehicles which have all of the following construction features in common:

(a) the number of lateral doors or the type of bodywork as defined in Section 1 of Part C when the manufacturer uses the criterion of point 1.1.2;

(b) the power plant with regard to the following construction features:

(i) the type of energy supply (internal combustion engine, electric motor or other);

(ii) the working principle (positive ignition, compression ignition or other);

(iii) the number and arrangement of cylinders in the case of internal combustion engine (L4, V6 or other);

(c) the number of axles;

(d) the number, and interconnection of powered axles;

(e) the number of steered axles;

(f) the stage of completion (e.g. complete/incomplete).

### 1.3. Version

1.3.1. A 'version' within a variant shall group the vehicles which have all the following features in common:

- (a) the technically permissible maximum laden mass;
- (b) the engine capacity in the case of internal combustion engine;
- (c) the maximum engine power output or the maximum continuous rated power (electric motor);
- (d) the nature of the fuel (petrol, gas oil, LPG, bi-fuel or other);
- (e) the maximum number of seating positions;
- (f) drive-by sound level;
- (g) exhaust emission level (for example Euro 5, Euro 6 or other);
- (h) combined or weighted, combined CO<sub>2</sub> emissions;
- (i) electric energy consumption (weighted, combined);
- (j) combined or weighted, combined fuel consumption;
- (k) the existence of a unique set of innovative technologies, as specified in Article 12 of Regulation (EC) No 443/2009<sup>(66)</sup>.

## 2. Categories M<sub>2</sub> and M<sub>3</sub>

### 2.1. Vehicle type

2.1.1. A 'vehicle type' shall consist of vehicles which have all of the following features in common:

- (a) the manufacturer's company name.  

A change in the legal form of ownership of the company does not require that a new approval has to be granted;
- (b) the category;
- (c) the following aspects of construction and design:
  - (i) the design and construction of the essential constituent elements forming the chassis;
  - (ii) the design and construction of the essential constituent elements forming the body structure in the case of a self-supporting body;
- (d) the number of decks (single or double);
- (e) the number of sections (rigid/articulated);
- (f) the number of axles;
- (g) the mode of energy supply (on-board or off-board);

---

*Status: EU Directives are being published on this site to aid cross referencing from UK legislation. After IP completion day (31 December 2020 11pm) no further amendments will be applied to this version.*

---

(h) in the case of multi-stage built vehicles, the manufacturer and the type of the previous stage vehicle.

2.1.2. A type shall consist of at least one variant and one version.

2.2. Variant

2.2.1. A 'variant' within a vehicle type shall group the vehicles which have all of the following construction features in common:

- (a) the type of bodywork as defined in Section 2 of Part C;
- (b) the class or combination of classes of vehicles as defined in point 2.1.1 of Annex I to Directive 2001/85/EC (only in the case of complete and completed vehicles);
- (c) the stage of completion (e.g. complete/incomplete/completed);
- (d) the power plant with regard to the following construction features:
  - (i) the type of energy supply (internal combustion engine, electric motor or other);
  - (ii) the working principle (positive ignition, compression ignition or other);
  - (iii) the number and arrangement of cylinders in the case of internal combustion engine (L6, V8 or other).

2.3. Version

2.3.1. A 'version' within a variant shall group the vehicles which have all the following features in common:

- (a) the technically permissible maximum laden mass;
- (b) the ability of the vehicle to tow a trailer or not;
- (c) the engine capacity in the case of internal combustion engine;
- (d) the maximum engine power output or the maximum continuous rated power (electric motor);
- (e) the nature of the fuel (petrol, gas oil, LPG, bi-fuel or other);
- (f) drive-by sound level;
- (g) exhaust emission level (for example Euro IV, Euro V or other).

3. **Category N<sub>1</sub>**

3.1. Vehicle type

3.1.1. A 'vehicle type' shall consist of vehicles which have all of the following features in common:

- (a) the manufacturer's company name.

A change in the legal form of ownership of the company does not require that a new approval has to be granted;

- (b) the design and assembly of the essential parts of the body structure in the case of a self-supporting body;

- (c) the design and the construction of the essential constituent elements forming the chassis in the case of a non self-supporting body;
  - (d) in the case of multi-stage built vehicles, the manufacturer and the type of the previous stage vehicle.
- 3.1.2. By way of derogation from the requirements of point 3.1.1(b), when the manufacturer uses the floor portion of the body structure as well the essential constituent elements forming the front part of the body structure located directly in front of the windscreen bay, in the construction of different kinds of bodywork (for example a van and a chassis-cab, different wheelbases and different roof heights), those vehicles may be considered as belonging to the same type. Evidence thereof shall be provided by the manufacturer.
- 3.1.3. A type shall consist of at least one variant and one version.
- 3.2. Variant
- 3.2.1. A 'variant' within a vehicle type shall group the vehicles which have all of the following construction features in common:
- (a) the number of lateral doors or the type of bodywork as defined in Section 3 of Part C (for complete and completed vehicles) when the manufacturer uses the criterion of point 3.1.2;
  - (b) the stage of completion (e.g. complete/incomplete/completed);
  - (c) the power plant with regard to the following construction features:
    - (i) the type of energy supply (internal combustion engine, electric motor or other);
    - (ii) the working principle (positive ignition, compression ignition or other);
    - (iii) the number and arrangement of cylinders in the case of internal combustion engine (L6, V8 or other);
  - (d) the number of axles;
  - (e) the number and interconnection of powered axles;
  - (f) the number of steered axles.
- 3.3. Version
- 3.3.1. A 'version' within a variant shall group the vehicles which have all the following features in common:
- (a) the technically permissible maximum laden mass;
  - (b) the engine capacity in the case of internal combustion engine;
  - (c) the maximum engine power output or maximum continuous rated power (electric motor);
  - (d) the nature of the fuel (petrol, gas oil, LPG, bi-fuel or other);
  - (e) the maximum number of seating positions;
  - (f) drive-by sound level;

---

*Status: EU Directives are being published on this site to aid cross referencing from UK legislation. After IP completion day (31 December 2020 11pm) no further amendments will be applied to this version.*

---

- (g) exhaust emission level (for example Euro 5, Euro 6 or other);
- (h) combined or weighted, combined CO<sub>2</sub> emissions;
- (i) electric energy consumption (weighted, combined);
- (j) combined or weighted, combined fuel consumption.

#### 4. **Categories N<sub>2</sub> and N<sub>3</sub>**

##### 4.1. Vehicle type

4.1.1. A 'vehicle type' shall consist of vehicles which have all of the following essential features in common:

- (a) the manufacturer's company name.

A change in the legal form of ownership of the company does not require that a new approval has to be granted;

- (b) the category;
- (c) the design and construction of the chassis that are common to a single line of product;
- (d) the number of axles;
- (e) in the case of multi-stage built vehicles, the manufacturer and the type of the previous stage vehicle.

4.1.2. A type shall consist of at least one variant and one version.

##### 4.2. Variant

4.2.1. A 'variant' within a vehicle type shall group the vehicles which have all of the following construction features in common:

- (a) the body structural concept or type of bodywork as referred to in Section 3 of Part C and in Appendix 2 (only for complete and completed vehicles);
- (b) the stage of completion (e.g. complete/incomplete/completed);
- (c) the power plant with regard to the following construction features:
  - (i) the type of energy supply (internal combustion engine, electric motor or other);
  - (ii) the working principle (positive ignition, compression ignition or other);
  - (iii) the number and arrangement of cylinders in the case of internal combustion engine (L6, V8 or other);

- (d) the number and interconnection of powered axles;
- (e) the number of steered axles.

##### 4.3. Version

4.3.1. A 'version' within a variant shall group the vehicles which have all the following features in common:

- (a) the technically permissible maximum laden mass;

- (b) the ability or not to tow a trailer as follows:
  - (i) an unbraked trailer;
  - (ii) a trailer with an inertia (or overrun) braking system as defined in point 2.12 of UNECE Regulation No 13;
  - (iii) a trailer with a continuous or semi-continuous braking system as defined in points 2.9 and 2.10 of UNECE Regulation No 13;
  - (iv) a trailer of category O<sub>4</sub> that results in a maximum mass of the combination not exceeding 44 tonnes;
  - (v) a trailer of category O<sub>4</sub> that results in a maximum mass of the combination exceeding 44 tonnes;
- (c) the engine capacity;
- (d) the maximum engine power output;
- (e) the nature of the fuel (petrol, gas oil, LPG, bi-fuel or other);
- (f) drive-by sound level;
- (g) exhaust emission level (for example Euro IV, Euro V or other).

## 5. Categories O<sub>1</sub> and O<sub>2</sub>

### 5.1. Vehicle type

5.1.1. A 'vehicle type' shall consist of vehicles which have all of the following features in common:

- (a) the manufacturer's company name.

A change in the legal form of ownership of the company does not require that a new approval has to be granted;
- (b) the category;
- (c) the concept as defined in section 4 of Part C;
- (d) the following aspects of construction and design:
  - (i) the design and construction of the essential constituent elements forming the chassis;
  - (ii) the design and construction of the essential constituent elements forming the body structure in the case of a self-supporting body;
- (e) the number of axles;
- (f) in the case of multi-stage built vehicles, the manufacturer and the type of the previous stage vehicle.

5.1.2. A type shall consist of at least one variant and one version.

### 5.2. Variant

5.2.1. A 'variant' within a vehicle type shall group the vehicles which have all of the following construction features in common:

---

*Status: EU Directives are being published on this site to aid cross referencing from UK legislation. After IP completion day (31 December 2020 11pm) no further amendments will be applied to this version.*

---

- (a) the kind of bodywork as referred to in Appendix 2 (for complete and completed vehicles);
- (b) the stage of completion (e.g. complete/incomplete/completed);
- (c) the type of braking system (e.g. unbraked/inertia/power).

### 5.3. Version

5.3.1. A 'version' within a variant shall group the vehicles which have all the following features in common:

- (a) the technically permissible maximum laden mass;
- (b) the concept of the suspension (air, steel or rubber suspension, torsion bar or other);
- (c) the concept of the drawbar (triangle, tube or other).

## 6. Categories O<sub>3</sub> and O<sub>4</sub>

### 6.1. Vehicle type

6.1.1. A 'vehicle type' shall consist of vehicles which have all of the following features in common:

- (a) the manufacturer's company name.

A change in the legal form of ownership of the company does not require that a new approval has to be granted;

- (b) the category;
- (c) the concept of the trailer with relation to the definitions in section 4 of Part C;
- (d) the following aspects of construction and design:
  - (i) the design and construction of the essential constituent elements forming the chassis;
  - (ii) the design and construction of the essential constituent elements forming the body structure in the case of trailers with a self-supporting body;
- (e) the number of axles;
- (f) in the case of multi-stage built vehicles, the manufacturer and the type of the previous stage vehicle.

6.1.2. A type shall consist of at least one variant and one version.

### 6.2. Variants

6.2.1. A 'variant' within a vehicle type shall group the vehicles which have all of the following construction and design features in common:

- (a) the kind of bodywork as referred to in Appendix 2 (for complete and completed vehicles);
- (b) the stage of completion (e.g. complete/incomplete/completed);
- (c) the concept of the suspensions (steel, air or hydraulic suspension);



- (d) the following technical features:
  - (i) the capability or not for the chassis to be extendible;
  - (ii) the deck height (normal, low loader, semi-low loader etc.).

### 6.3. Versions

6.3.1. A 'version' within a variant shall group the vehicles which have all the following features in common:

- (a) the technically permissible maximum laden mass;
- (b) the subdivisions or combination of subdivisions referred to in points 3.2 and 3.3 of Annex I to Directive 96/53/EC into which the axle spacing between two consecutive axles forming a group belongs;
- (c) the definition of the axles in the following respects:
  - (i) lift axles (number and position);
  - (ii) loadable axles (number and position);
  - (iii) steered axle (number and position).

## 7. Common requirements for all vehicle categories

7.1. When a vehicle falls into several categories because of its maximum mass or the number of seating positions or both, the manufacturer may select to use the criteria of one or the other vehicle category for the definition of the variants and the versions.

7.1.1. Examples:

- (a) a vehicle 'A' may be type-approved as N<sub>1</sub> (3,5 tonnes) and N<sub>2</sub> (4,2 tonnes) in relation to its maximum mass. In such a case, the parameters mentioned in category N<sub>1</sub> may be used also for the vehicle that falls into category N<sub>2</sub> (or vice-versa);
- (b) A vehicle 'B' may be type-approved as M<sub>1</sub> and M<sub>2</sub> in relation to the number of seating positions (7 + 1 or 10 + 1), the parameters mentioned in category M<sub>1</sub> may be used also for the vehicle that falls into category M<sub>2</sub> (or vice-versa).

7.2. A vehicle of category N may be type-approved against the provisions required for category M<sub>1</sub> or M<sub>2</sub>, as the case may be, when it is intended to be converted into a vehicle of that category during the next step of a multi-stage type-approval procedure.

7.2.1. This option shall only be permitted for incomplete vehicles.

Such vehicles shall be identified by a specific variant code given by the manufacturer of the base vehicle.

7.3. Type-, variant- and version designations

7.3.1. The manufacturer shall allocate an alphanumeric code to each vehicle type, variant and version, made up of Roman letters and/or Arabic numerals.

The use of brackets and hyphens is permitted provided they do not replace a letter or a numeral.

7.3.2. The whole code shall be designated: Type-Variant-Version or 'TVV'.

---

*Status: EU Directives are being published on this site to aid cross referencing from UK legislation. After IP completion day (31 December 2020 11pm) no further amendments will be applied to this version.*

---

- 7.3.3. The TVV shall clearly and unequivocally identify a unique combination of technical features in relation to the criteria defined in Part B of this Annex.
- 7.3.4. The same manufacturer may use the same code in order to define a vehicle type when the latter falls in two or more categories.
- 7.3.5. The same manufacturer shall not use the same code in order to define a vehicle type for more than one type-approval within the same vehicle category.
- 7.4. Number of characters for the TVV
- 7.4.1. The number of characters shall not exceed:
- (a) 15 for the code of the vehicle type;
  - (b) 25 for the code of one variant;
  - (c) 35 for the code of one version.
- 7.4.2. The complete alphanumeric 'TVV' shall not contain more than 75 characters.
- 7.4.3. When the TVV is used as a whole, a space shall be left between the type, the variant and the version.

Example of such TVV: 159AF[...space]0054[...space]977K(BE).

## PART C

### Definitions of types of bodywork

#### 0. General

- 0.1. The type of bodywork referred to in Section 9 of Annex I and Part 1 of Annex III as well as the code for bodywork referred to in Item 38 of Annex IX shall be indicated by means of codes.

The list of codes shall apply primarily to complete and completed vehicles.

- 0.2. As regards vehicles of categories M, the type of bodywork shall consist of two letters as specified in Sections 1 and 2.
- 0.3. As regards vehicles of categories N and O, the type of bodywork shall consist of two letters as referred to in Sections 3 and 4.
- 0.4. Where necessary (especially for the types of bodywork referred to respectively in points 3.1 and 3.6 and in points 4.1 to 4.4), they shall be supplemented by two digits.
- 0.4.1. The list of digits shall be laid down in Appendix 2 to this Annex.
- 0.5. For special purpose vehicles, the type of bodywork to be used shall be linked to the category of the vehicle.

#### 1. Vehicles belonging to category M<sub>1</sub>

Ref.	Code	Name	Definition
1.1.	AA	Saloon	a vehicle defined in term 3.1.1.1

**Status:** EU Directives are being published on this site to aid cross referencing from UK legislation. After IP completion day (31 December 2020 11pm) no further amendments will be applied to this version.

			of Standard ISO 3833:1977, fitted with at least four side windows.
1.2.	AB	Hatchback	a saloon as defined in 1.1 with a hatch at the rear end of the vehicle.
1.3.	AC	Station wagon	a vehicle defined in term 3.1.1.4 of Standard ISO 3833:1977.
1.4.	AD	Coupé	a vehicle defined in term 3.1.1.5 of Standard ISO 3833:1977.
1.5.	AE	Convertible	a vehicle defined in terms No 3.1.1.6 of Standard ISO 3833:1977. However a convertible may have no door.
1.6.	AF	Multi-purpose vehicle	a vehicle other than AG and those mentioned in AA to AE intended for carrying persons and their luggage or occasionally goods, in a single compartment.
1.7.	AG	Truck station wagon	a vehicle defined in terms No 3.1.1.4.1 of Standard ISO 3833:1977. However, the luggage compartment must be completely separated from the passenger compartment. In addition, the reference point of the driver's seating position needs not to be at least at 750 mm above the surface supporting the vehicle.

*Status: EU Directives are being published on this site to aid cross referencing from UK legislation. After IP completion day (31 December 2020 11pm) no further amendments will be applied to this version.*

## 2. Vehicles belonging to category M<sub>2</sub> or M<sub>3</sub>

Ref.	Code	Name	Definition
2.1.	CA	Single-deck vehicle	a vehicle where the spaces provided for persons are arranged in a single level or in a way that they do not constitute two superimposed levels;
2.2.	CB	Double-deck vehicle	a vehicle defined in point 2.1.6 of Annex I to Directive 2001/85/EC;
2.3.	CC	Single-deck articulated vehicle	a vehicle defined in point 2.1.3 of Annex I to Directive 2001/85/EC with a single deck;
2.4.	CD	Double-deck articulated vehicle	a vehicle defined in point 2.1.3.1 of Annex I to Directive 2001/85/EC;
2.5.	CE	Low-floor single-deck vehicle	a vehicle defined in point 2.1.4 of Annex I to Directive 2001/85/EC with a single deck;
2.6.	CF	Low-floor double-deck vehicle	a vehicle defined in point 2.1.4 of Annex I to Directive 2001/85/EC with a double deck;
2.7.	CG	Articulated low-floor single-deck vehicle	a vehicle that combines the technical features of entries 2.3 and 2.5;
2.8.	CH	Articulated low-floor double-deck vehicle	a vehicle that combines the technical features of entries 2.4 and 2.6;
2.9.	CI	Open top single deck vehicle	a vehicle with partial roof or without roof;
2.10.	CJ	Open top double deck vehicle	a vehicle without roof over all or part of its upper deck;

2.11.	CX	Bus chassis	an incomplete vehicle with just chassis rails or tube assembly, power train, axles, which is intended to be completed with bodywork, customised to the needs of the transport operator.
-------	----	-------------	---

### 3. Motor vehicles of category N<sub>1</sub>, N<sub>2</sub> or N<sub>3</sub>

Ref.	Code	Name	Definition
3.1.	BA	Lorry	a vehicle which is designed and constructed exclusively or principally for conveying goods. It may also tow a trailer.
3.2.	BB	Van	a lorry with the compartment where the driver is located and cargo area within a single unit;
3.3.	BC	Tractor unit for semi-trailer	a towing vehicle which is designed and constructed exclusively or principally to tow semi-trailers;
3.4.	BD	Road tractor	a towing vehicle which is designed and constructed exclusively to tow trailers other than semi-trailers;
3.5.	BE	Pick-up truck	a vehicle of a maximum mass not exceeding 3 500 kg in which the seating positions and the cargo area are not located in a single compartment;

*Status: EU Directives are being published on this site to aid cross referencing from UK legislation. After IP completion day (31 December 2020 11pm) no further amendments will be applied to this version.*

3.6.	BX	Chassis-cab or chassis-cowl	an incomplete vehicle with just a cabin (complete or partial), chassis rails, power train, axles, which is intended to be completed with bodywork, customised to the needs of the transport operator.
------	----	-----------------------------	---

#### 4. Vehicles of category O

Ref.	Code	Name	Definition
4.1.	DA	Semi-trailer	a trailer which is designed and constructed to be coupled to a tractor unit or to a converter dolly and to impose a substantial vertical load on the towing vehicle or on the converter dolly. The coupling to be used for a vehicle combination shall consist of a king pin and a fifth wheel.
4.2.	DB	Drawbar trailer	a trailer having at least two axles, of which at least one is a steered axle: <ul style="list-style-type: none"> <li>(a) equipped with a towing device which can move vertically (in relation to the trailer) and</li> <li>(b) that transmits less than 100 daN as a static vertical load to the</li> </ul>

*Status: EU Directives are being published on this site to aid cross referencing from UK legislation. After IP completion day (31 December 2020 11pm) no further amendments will be applied to this version.*

			towing vehicle.
4.3.	DC	Centre-axle trailer	a trailer where the axle(s) is (are) positioned close to the centre of gravity of the vehicle (when uniformly loaded) so that only a small static vertical load, not exceeding 10 % of that corresponding to the maximum mass of the trailer or a load of 1 000 daN (whichever is the lesser) is transmitted to the towing vehicle.
4.4.	DE	Rigid drawbar trailer	a trailer with one axle or one group of axles fitted with a drawbar which transmits a static load not exceeding 4 000 daN to the towing vehicle due to its construction and which does not meet the definition of a centre-axle trailer. The coupling to be used for a vehicle combination shall not consist of a king pin and a fifth wheel.

---

*Status: EU Directives are being published on this site to aid cross referencing from UK legislation. After IP completion day (31 December 2020 11pm) no further amendments will be applied to this version.*

---

## Appendix 1

### Procedure for checking whether a vehicle can be categorised as off-road vehicle

#### 0. General

0.1. For the purposes of classification of a vehicle as off-road vehicle, the procedure described in this Appendix shall apply.

#### 1. Test conditions for geometric measurements

1.1. Vehicles belonging to category M<sub>1</sub> or N<sub>1</sub> shall be in unloaded conditions with a manikin of the 50th percentile male installed on the driver's seat and fitted with coolant fluid, lubricants, fuel, tools, spare-wheel (if fitted as OEM equipment).

The manikin may be replaced by a similar device having the same mass.

1.2. Vehicles other than those referred to in point 1.1 shall be loaded to their technically permissible maximum laden mass.

The distribution of the mass on the axles shall be the one that represents the worst case with respect to compliance with the respective criteria.

1.3. A vehicle representative of the type shall be submitted to the technical service in the conditions specified in point 1.1 or 1.2. The vehicle shall be in a stationary position with its wheels set straight ahead.

The ground on which measurements are made shall be as flat and horizontal (maximum of inclination 0,5 %) as possible.

#### 2. Measurement of approach, departure and ramp angles

2.1. The approach angle shall be measured in accordance with Item 6.10 of Standard ISO 612:1978.

2.2. The departure angle shall be measured in accordance with Item 6.11 of Standard ISO 612:1978.

2.3. The ramp angle shall be measured in accordance with Item 6.9 of Standard ISO 612:1978.

2.4. When measuring the departure angle rear underrun protection devices which are adjustable in height may be set in the upper position.

2.5. The prescription in point 2.4 shall not be construed as an obligation for the base vehicle to be fitted with a rear underrun protection as original equipment. However, the base vehicle manufacturer shall inform the next stage manufacturer that the vehicle has to comply with the requirements on departure angle when fitted with a rear underrun protection.

#### 3. Measurement of ground clearance

3.1. Ground clearance between the axles

3.1.1. 'Ground clearance between the axles' means the shortest distance between the ground plane and the lowest fixed point of the vehicle.

For the application of the definition, the distance between the last axle of a front group of axle and the first axle of a rear group of axle shall be considered.



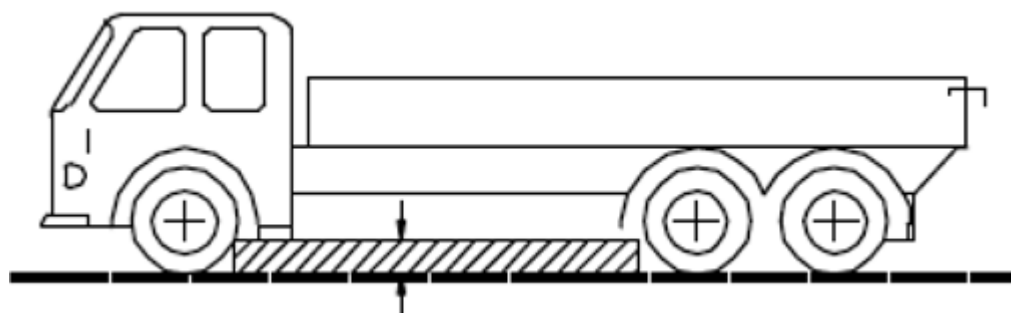

3.1.2. No rigid part of the vehicle may project into the shaded area shown on the figure.

3.2. Ground clearance beneath one axle

3.2.1. ‘Ground clearance beneath one axle’ means the distance beneath the highest point of the arc of a circle passing through the centre of the tyre footprint of the wheels on one axle (the inner wheels in the case of twin tyres) and touching the lowest fixed point of the vehicle between the wheels.

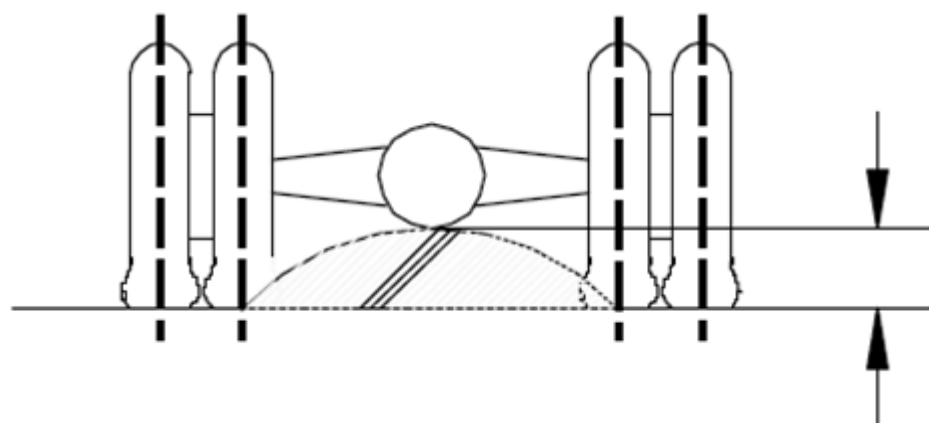

3.2.2. Where appropriate, the measurement of ground clearance shall be conducted on each of the several axles of a group of axles.

#### 4. **Gradeability**

4.1. ‘Gradeability’ means the ability of a vehicle to negotiate a gradient.

4.2. To the effect of checking the gradeability of an incomplete and a complete vehicle of category M<sub>2</sub>, M<sub>3</sub>, N<sub>2</sub> and N<sub>3</sub>, a test shall be performed.

4.3. The test shall be conducted by the technical service on a vehicle representative of the type to be tested.

4.4. At the request of the manufacturer and under the conditions specified in Annex XVI, the gradeability of a vehicle type may be demonstrated by virtual testing.

#### 5. **Test conditions and pass-fail criterion**

5.1. Until 31 October 2014, the conditions set out in section 7.5 of Annex I to Directive 97/27/EC shall apply.

---

*Status: EU Directives are being published on this site to aid cross referencing from UK legislation. After IP completion day (31 December 2020 11pm) no further amendments will be applied to this version.*

---

As from 1 November 2014, test conditions adopted under Regulation (EC) No 661/2009 of the European Parliament and of the Council<sup>(67)</sup> in accordance with Article 14 of that Regulation shall apply.

- 5.2. The vehicle shall climb the gradient at a steady speed without any wheel slipping, longitudinally or laterally.

## Appendix 2

**Digits used to supplement the codes to be used for various kinds of bodywork**

- 01 Flat bed;
- 02 Drop-side;
- 03 Box body;
- 04 Conditioned body with insulated walls and equipment to maintain the interior temperature;
- 05 Conditioned body with insulated walls but without equipment to maintain the interior temperature;
- 06 Curtain-sided;
- 07 Swap body (interchangeable superstructure);
- 08 Container carrier;
- 09 Vehicles fitted with hook lift;
- 10 Tipper;
- 11 Tank;
- 12 Tank intended for transport of dangerous goods;
- 13 Livestock carrier;
- 14 Vehicle transporter;
- 15 Concrete mixer;
- 16 Concrete pump vehicle;
- 17 Timber;
- 18 Refuse collection vehicle;
- 19 Street sweeper, cleansing and drain clearing;
- 20 Compressor;
- 21 Boat carrier;
- 22 Glider carrier;
- 23 Vehicles for retail or display purposes;
- 24 Recovery vehicle;
- 25 Ladder vehicle;
- 26 Crane lorry (other than a mobile crane as defined in Section 5 of Part A of Annex II);
- 27 Aerial work platform vehicle;
- 28 Digger derrick vehicle;
- 29 Low floor trailer;

---

*Status: EU Directives are being published on this site to aid cross referencing from UK legislation. After IP completion day (31 December 2020 11pm) no further amendments will be applied to this version.*

---

- 30 Glazing transporter;
- 31 Fire engine;
- 99 Bodywork that is not included in the present list.]

### [<sup>F1</sup>ANNEX III

#### INFORMATION DOCUMENT FOR THE PURPOSE OF EC TYPE-APPROVAL OF VEHICLES (For explanatory notes, please refer to last page of Annex I)

#### PART I

The following information shall be supplied in triplicate and include a list of contents. Any drawings shall be supplied in appropriate scale and in sufficient detail on size A4, or on a folder of A4 format. Photographs, if any, shall show sufficient detail.

- A. Categories M and N
  - 0. GENERAL
    - 0.1. Make (trade name of manufacturer): ...
    - 0.2. Type: ...
      - 0.2.1. Commercial name(s) (if available): ...
    - 0.3. Means of identification of type, if marked on the vehicle (<sup>b</sup>): ...
      - 0.3.1. Location of that marking: ...
    - 0.4. Category of vehicle (<sup>c</sup>): ...
      - 0.4.1. Classification(s) according to the dangerous goods which the vehicle is intended to transport: ...
    - [<sup>F3</sup>0.5. Company name and address of manufacturer: ...]
    - 0.8. Name(s) and address(es) of assembly plant(s): ...
    - 0.9. Name and address of the manufacturer's representative (if any): ...
  - 1. GENERAL CONSTRUCTION CHARACTERISTICS OF THE VEHICLE
    - 1.1. Photographs and/or drawings of a representative vehicle: ...
    - 1.3. Number of axles and wheels: ...
      - 1.3.1. Number and position of axles with twin wheels: ...
      - 1.3.2. Number and position of steered axles: ...
      - 1.3.3. Powered axles (number, position, interconnection): ...
    - 1.4. Chassis (if any) (overall drawing): ...

- 1.6. Position and arrangement of the engine: ...
- 1.8. Hand of drive: left/right <sup>(1)</sup>
- 1.8.1. Vehicle is equipped to be driven in right/left <sup>(1)</sup> hand traffic
- [<sup>F4</sup>1.9. Specify if the towing vehicle is intended to tow semi-trailers or other trailers and, if the trailer is a semi-, drawbar-, centre-axle- or rigid drawbar trailer: ...
- 1.10. Specify if the vehicle is specially designed for the controlled-temperature carriage of goods: ...]
- [<sup>F3</sup>2. MASSES AND DIMENSIONS <sup>(f)</sup><sup>(g)</sup><sup>(7)</sup>  
(in kg and mm) (Refer to drawing where applicable)]
- 2.1. Wheelbase(s) (fully loaded) <sup>(g1)</sup>:
- 2.1.1. *Two-axle vehicles*: ...
- 2.1.2. Vehicles with three or more axles
- 2.1.2.1. Axle spacing between consecutive axles going from the foremost to the rearmost axle:  
...
- 2.1.2.2. Total axle spacing: ...
- 2.3.1. Track of each steered axle <sup>(g4)</sup>: ...
- 2.3.2. Track of all other axles <sup>(g4)</sup>: ...
- 2.4. Range of vehicle dimensions (overall)
- 2.4.1. For chassis without bodywork
- 2.4.1.1. Length <sup>(g5)</sup>: ...
- 2.4.1.1.1. Maximum permissible length: ...
- 2.4.1.1.2. Minimum permissible length: ...
- 2.4.1.2. Width <sup>(g7)</sup>: ...
- 2.4.1.2.1. Maximum permissible width: ...
- 2.4.1.2.2. Minimum permissible width: ...
- 2.4.1.3. Height (in running order) <sup>(g8)</sup> (for suspensions adjustable for height, indicate normal running position): ...
- 2.4.2. For chassis with bodywork
- 2.4.2.1. Length <sup>(g5)</sup>: ...
- 2.4.2.1.1. Length of the loading area: ...
- 2.4.2.2. Width <sup>(g7)</sup>: ...

---

*Status: EU Directives are being published on this site to aid cross referencing from UK legislation. After IP completion day (31 December 2020 11pm) no further amendments will be applied to this version.*

---

- 2.4.2.2.1. Thickness of the walls (in the case of vehicles designed for controlled-temperature transport of goods): ...
- 2.4.2.3. Height (in running order) <sup>(g8)</sup> (for suspensions adjustable for height, indicate normal running position): ...
- [<sup>F4</sup>2.5. **Minimum mass on the steering axle(s) for incomplete vehicles: ...]**
- [<sup>F3</sup>2.6. **Mass in running order** <sup>(h)</sup>
- (a) minimum and maximum for each variant: ...
- (b) mass of each version (a matrix must be provided): ...
- 2.6.1. Distribution of this mass among the axles and, in the case of a semi-trailer a rigid drawbar trailer or a centre-axle trailer, the mass on the coupling:
- (a) minimum and maximum for each variant: ...
- (b) mass of each version (a matrix must be provided): ...]
- [<sup>F4</sup>2.6.2. Mass of the optional equipment (as defined in point (5) of Article 2 of Regulation (EU) No 1230/2012: ...]
- 2.7. **Minimum mass of the completed vehicle** as stated by the manufacturer, in the case of an incomplete vehicle: ...
- 2.8. **Technically permissible maximum laden mass** stated by the manufacturer <sup>(i)</sup><sup>(3)</sup>: ...
- 2.8.1. Distribution of this mass among the axles and, in the case of a semi-trailer or centre-axle trailer, load on the coupling point <sup>(3)</sup>: ...
- 2.9. **Technically permissible maximum mass on each axle: ...**
- [<sup>F3</sup>2.10. **Technically permissible mass on each group of axles: ...]**
- [<sup>F3</sup>2.11. **Technically permissible maximum towable mass of the towing vehicle**
- in case of:]
- 2.11.1. Drawbar trailer: ...
- 2.11.2. Semi-trailer: ...
- 2.11.3. Centre-axle trailer: ...
- [<sup>F3</sup>2.11.4. Rigid drawbar trailer: ...]
- [<sup>F4</sup>2.11.5. Technically permissible maximum laden mass of the combination <sup>(3)</sup>: ...]
- 2.11.6. Maximum mass of unbraked trailer: ...
- [<sup>F3</sup>2.12. **Technically permissible maximum mass at the coupling point:**
- 2.12.1. of a towing vehicle: ...
- 2.12.2. of a semi-trailer, a centre-axle trailer or a rigid drawbar trailer: ...]
- [<sup>F3</sup>2.16. **Registration/in service maximum permissible masses (optional)**

- 2.16.1. Registration/in service maximum permissible laden mass: ...
- 2.16.2. Registration/in service maximum permissible mass on each axle and, in the case of a semi-trailer or centre-axle trailer, intended load on the coupling point stated by the manufacturer if lower than the technically permissible maximum mass on the coupling point: ...
- 2.16.3. Registration/in service maximum permissible mass on each group of axles: ...
- 2.16.4. Registration/in service maximum permissible towable mass: ...
- 2.16.5. Registration/in service maximum permissible mass of the combination: ...]
- 3. POWER PLANT <sup>(k)</sup>
- 3.1. **Manufacturer of the engine:** ...
- 3.1.1. Manufacturer's engine code (as marked on the engine or other means of identification): ...
- 3.1.2. Approval number (if appropriate) including fuel identification marking: ...  
(heavy-duty vehicles only)
- 3.2. Internal combustion engine
- [<sup>F6</sup>3.2.1.1. Working principle: positive ignition/compression ignition/dual-fuel <sup>(1)</sup>  
Cycle four stroke/two stroke/rotary <sup>(1)</sup>]
- [<sup>F7</sup>3.2.1.1. Type of dual-fuel engine: Type 1A/Type 1B/Type 2A/Type 2B/Type 3B <sup>(1)</sup><sup>(x1)</sup>
- 3.2.1.1.2. Gas Energy Ratio over the hot part of the WHTC test-cycle: ... %]
- 3.2.1.2. Number and arrangement of cylinders: ...
- 3.2.1.3. Engine capacity <sup>(m)</sup>: ..... cm<sup>3</sup>
- 3.2.1.6. Normal engine idling speed <sup>(2)</sup>: ..... min<sup>-1</sup>
- [<sup>F7</sup>3.2.1.6.2. Fuel on diesel: yes/no <sup>(1)</sup><sup>(x1)</sup>]
- 3.2.1.8. Maximum net power <sup>(n)</sup>: ..... kW at ..... min<sup>-1</sup> (manufacturer's declared value)
- [<sup>F8</sup>3.2.1.1. (Euro VI only) Manufacturer references of the Documentation package required by Articles 5, 7 and 9 of Regulation (EU) No 582/2011 enabling the approval authority to evaluate the emission control strategies and the systems on-board the engine to ensure the correct operation of NO<sub>x</sub> control measures]
- 3.2.2.1. Light-duty vehicles: Diesel/Petrol/LPG/NG or Biomethane/Ethanol (E 85)/Biodiesel/Hydrogen <sup>(1)</sup> <sup>(6)</sup>
- [<sup>F6</sup>3.2.2.2. Heavy duty vehicles Diesel/Petrol/LPG/NG-H/NG-L/NG-HL/Ethanol (ED95)/Ethanol (E85)/LNG/LNG<sub>20</sub> <sup>(1)</sup><sup>(6)</sup>]

---

*Status: EU Directives are being published on this site to aid cross referencing from UK legislation. After IP completion day (31 December 2020 11pm) no further amendments will be applied to this version.*

---

[<sup>F8</sup>3.2.2.2 (Euro VI only) Fuels compatible with use by the engine declared by the manufacturer in accordance with Section 1.1.3 of Annex I to Regulation (EU) No 582/2011 (as applicable)]

3.2.2.4. Vehicle fuel type: Mono fuel, Bi fuel, Flex fuel (<sup>1</sup>)

3.2.2.5. Maximum amount of biofuel acceptable in fuel (manufacturer's declared value): ..... % by volume

3.2.3. Fuel tank(s)

3.2.3.1. Service fuel tank(s)

3.2.3.1.1. Number and capacity of each tank: ...

3.2.3.2. Reserve fuel tank(s)

3.2.3.2.1. Number and capacity of each tank: ...

3.2.4. Fuel feed

3.2.4.1. By carburettor(s): yes/no (<sup>1</sup>)

[<sup>F6</sup>3.2.4.2 By fuel injection (compression ignition or dual-fuel only): yes/no (<sup>1</sup>)]

3.2.4.2. Working principle: direct injection/pre-chamber/swirl chamber (<sup>1</sup>)

3.2.4.3. By fuel injection (positive ignition only): yes/no (<sup>1</sup>)

3.2.7. Cooling system: liquid/air (<sup>1</sup>)

3.2.8. Intake system

3.2.8.1. Pressure charger: yes/no (<sup>1</sup>)

3.2.8.2. Intercooler: yes/no (<sup>1</sup>)

[<sup>F8</sup>3.2.8.3 (Euro VI only) Actual Intake system depression at rated engine speed and at 100 % load on the vehicle: kPa]

3.2.9. Exhaust system

[<sup>F8</sup>3.2.9.2 (Euro VI only) Description and/or drawing of the elements of the exhaust system that are not part of the engine system]

[<sup>F8</sup>3.2.9.3 (Euro VI only) Actual exhaust back pressure at rated engine speed and at 100 % load on the vehicle (compression-ignition engines only): ... kPa]

3.2.9.4. Type, marking of exhaust silencer(s): ...

Where relevant for exterior noise, reducing measures in the engine compartment and on the engine: ...

3.2.9.5. Location of the exhaust outlet: ...

[<sup>F8</sup>3.2.9.7 (Euro VI only) Acceptable Exhaust system volume: ... dm<sup>3</sup>]

3.2.12. Measures taken against air pollution



[<sup>F8</sup>3.2.12.1 (Euro VI only) Device for recycling crankcase gases: yes/no (<sup>2</sup>)

If yes, description and drawings:

If no, compliance with Annex V to Regulation (EU) No 582/2011 required]

3.2.12.2. Additional pollution control devices (if any, and if not covered by another heading)

3.2.12.2.1 Catalytic converter: yes/no (<sup>1</sup>)

3.2.12.2.1.1 Regeneration systems/method of exhaust after-treatment systems, description: ...

3.2.12.2.1.1.1 Consumable reagents: yes/no (<sup>1</sup>)

3.2.12.2.1.1.2 Type and concentration of reagent needed for catalytic action: ...

3.2.12.2.2 Oxygen sensor: yes/no (<sup>1</sup>)

3.2.12.2.3 Air injection: yes/no (<sup>1</sup>)

3.2.12.2.4 Exhaust gas recirculation: yes/no (<sup>1</sup>)

3.2.12.2.5 Evaporative emissions control system: yes/no (<sup>1</sup>)

3.2.12.2.6 Particulate trap: yes/no (<sup>1</sup>)

[<sup>F8</sup>3.2.12.2.7 Other systems: yes/no (<sup>1</sup>)

3.2.12.2.6 Description and operation]

3.2.12.2.7 On-board-diagnostic (OBD) system: yes/no (<sup>1</sup>)

[<sup>F8</sup>3.2.12.2.7.0.1 (Euro VI only) Number of OBD engine families within the engine family

3.2.12.2.7.0.1 (Euro VI only) List of the OBD engine families (when applicable)

3.2.12.2.7.0.1 (Euro VI only) Number of the OBD engine family the parent engine / the engine member belongs to:

3.2.12.2.7.0.1 (Euro VI only) Manufacturer references of the OBD-Documentation required by Article 5(4)(c) and Article 9(4) of Regulation (EU) No 582/2011 and specified in Annex X to that Regulation for the purpose of approving the OBD system

3.2.12.2.7.0.1 (Euro VI only) When appropriate, manufacturer reference of the Documentation for installing in a vehicle an OBD equipped engine system

3.2.12.2.7.0.1 (Euro VI uniquement) Le cas échéant, référence du constructeur du dossier de documentation relatif au montage sur le véhicule du système OBD d'un moteur réceptionné]

<sup>F9</sup>3.2.12.2.7.0.7. ....

<sup>F9</sup>3.2.12.2.7.0.8. ....

[<sup>F8</sup>[<sup>F6</sup>3.2.12.2.7.0.5 (Euro VI only) OBD Communication protocol standard: (<sup>8</sup>)]

3.2.12.2.7.0.5 (Euro VI only) Manufacturer reference of the OBD related information required by Article 5(4)(d) and Article 9(4) of Regulation (EU) No 582/2011 for the purpose

---

*Status: EU Directives are being published on this site to aid cross referencing from UK legislation. After IP completion day (31 December 2020 11pm) no further amendments will be applied to this version.*

---

of complying with the provisions on access to vehicle OBD and vehicle Repair and Maintenance Information, or

3.2.12.2.7.8.1 An alternative to a manufacturer reference provided in Section 3.2.12.2.7.7 reference of the attachment to the information document set out in Appendix 4 of Annex III to Regulation (EU) No 582/2011 that contains the following table, once completed according to the given example:

Component — Fault code — Monitoring strategy — Fault detection criteria — MI activation criteria — Secondary parameters — Preconditioning — Demonstration test  
Catalyst — P0420 — Oxygen sensor 1 and 2 signals — Difference between sensor 1 and sensor 2 signals — 3rd cycle — Engine speed, engine load, A/F mode, catalyst temperature — Two Type 1 cycles — Type 1]

[F7 3.2.12.2.7.8.2 (Euro VI only) OBD components on-board the vehicle

3.2.12.2.7.8.1 List of OBD components on-board the vehicle

3.2.12.2.7.8.2 Written description and/or drawing of the MI <sup>(10)</sup>

3.2.12.2.7.8.3 Written description and/or drawing of the OBD off-board communication interface <sup>(10)</sup>

3.2.12.2.8 Other systems (description and operation): ...

[F8 3.2.12.2.8.1 (Euro VI only) Systems to ensure the correct operation of NO<sub>x</sub> control measures

[F6 3.2.12.2.8.2 Driver inducement system]

[F7 3.2.12.2.8.3 (Euro VI only) Engine with permanent deactivation of the driver inducement, for use by the rescue services or in vehicles specified in point (b) of Article 2(3) of this Directive: yes/no <sup>(1)</sup>

3.2.12.2.8.4 (Euro VI only) Number of OBD engine families within the engine family considered when ensuring the correct operation of NO<sub>x</sub> control measures

3.2.12.2.8.5 (Euro VI only) List of the OBD engine families (when applicable)

3.2.12.2.8.6 (Euro VI only) Number of the OBD engine family the parent engine / the engine member belongs to

3.2.12.2.8.7 (Euro VI only) Lowest concentration of the active ingredient present in the reagent that does not activate the warning system (CD<sub>min</sub>): (% vol.)

3.2.12.2.8.8 (Euro VI only) When appropriate, manufacturer reference of the Documentation for installing in a vehicle the systems to ensure the correct operation of NO<sub>x</sub> control measures

3.2.12.2.8.9 Components on-board the vehicle of the systems ensuring the correct operation of NO<sub>x</sub> control measures

3.2.12.2.8.10 Activation of the creep mode:

‘disable after restart’ / ‘disable after fuelling’ / ‘disable after parking’ <sup>(7)</sup>

3.2.12.2.8.11 When appropriate, manufacturer reference of the documentation package related to the installation on the vehicle of the system ensuring the correct operation of NO<sub>x</sub> control measures of an approved engine

- 3.2.12.2.8 [Written description and/or drawing of the warning signal <sup>(6)</sup>]
- 3.2.12.2.9 Torque limiter: yes/no <sup>(1)</sup>
- 3.2.13.1. Location of the absorption coefficient symbol (compression ignition engines only): ...
- 3.2.15. LPG fuelling system: yes/no <sup>(1)</sup>
- 3.2.16. NG fuelling system: yes/no <sup>(1)</sup>
- [<sup>F8</sup>3.2.17.8 (Euro VI only) Self adaptive feature? Yes/No <sup>(1)</sup>]
- 3.2.17.8.1 (Euro VI only) Calibration for a specific gas composition NG-H/NG-L/NG-HL <sup>(1)</sup>  
Transformation for a specific gas composition NG-H<sub>t</sub>/NG-L<sub>t</sub>/NG-HL<sub>t</sub> <sup>(1)</sup>]
- 3.3. Electric motor
- 3.3.1. Type (winding, excitation): ...
- 3.3.1.1. Maximum hourly output: ..... kW
- [<sup>F10</sup>3.3.1.1 Maximum net power <sup>(n)</sup> ... kW  
(manufacturer's declared value)
- 3.3.1.1.2. Maximum 30 minutes power <sup>(n)</sup> ... kW  
(manufacturer's declared value)]
- 3.3.1.2. Operating voltage: ..... V
- 3.3.2. Battery
- 3.3.2.4. Position: ...
- 3.4. Engine or motor combination
- 3.4.1. Hybrid electric vehicle: yes/no <sup>(1)</sup>
- 3.4.2. Category of hybrid electric vehicle: off-vehicle charging/not off-vehicle charging: <sup>(1)</sup>
- [<sup>F8</sup>3.5.4. (Euro VI only) CO<sub>2</sub> emissions for heavy duty engines
- [<sup>F6</sup>3.5.4.1 CO<sub>2</sub> mass emissions WHSC test <sup>(x3)</sup>: ... g/kWh
- 3.5.4.2. CO<sub>2</sub> mass emissions WHSC test in diesel mode <sup>(x2)</sup>: ... g/kWh]
- [<sup>F7</sup>3.5.4.3 CO<sub>2</sub> mass emissions WHSC test in dual-fuel mode <sup>(x1)</sup>: ... g/kWh
- 3.5.4.4. CO<sub>2</sub> mass emissions WHTC test <sup>(9)(x3)</sup>: ... g/kWh
- 3.5.4.5. CO<sub>2</sub> mass emissions WHTC test in diesel mode <sup>(9)(x2)</sup>: ... g/kWh
- 3.5.4.6. CO<sub>2</sub> mass emissions WHTC test in dual-fuel mode <sup>(9)(x1)</sup>: ... g/kWh]
- 3.5.5. (Euro VI only) Fuel consumption for heavy duty engines

*Status: EU Directives are being published on this site to aid cross referencing from UK legislation. After IP completion day (31 December 2020 11pm) no further amendments will be applied to this version.*

[<sup>F6</sup>3.5.5.1 Fuel consumption WHSC test (<sup>x3</sup>): ... g/kWh

3.5.5.2. Fuel consumption WHSC test in diesel mode (<sup>x2</sup>): ... g/kWh]

[<sup>F7</sup>3.5.5.3 Fuel consumption WHSC test in dual-fuel mode (<sup>x1</sup>): ... g/kWh

3.5.5.4. Fuel consumption WHTC test (<sup>9</sup>)(<sup>x3</sup>): ... g/kWh

3.5.5.5. Fuel consumption WHTC test in diesel mode (<sup>9</sup>)(<sup>x2</sup>): ... g/kWh

3.5.5.6. Fuel consumption WHTC test in dual-fuel mode (<sup>9</sup>)(<sup>x1</sup>): ... g/kWh]]

3.6.5. Lubricant temperature

Minimum: ..... K

Maximum: ..... K

4. TRANSMISSION (<sup>P</sup>)

4.2. **Type** (mechanical, hydraulic, electric, etc.): ...

4.5. Gearbox

4.5.1. *Type* (manual/automatic/CVT (continuously variable transmission)) (<sup>1</sup>)

4.6. Gear ratios

<b>Gear</b>	<b>Internal gearbox ratios (ratios of engine to gearbox output shaft revolutions)</b>	<b>Final drive ratio(s) (ratio of gearbox output shaft to driven wheel revolutions)</b>	<b>Total gear ratios</b>
Maximum for CVT			
1			
2			
3			
...			
Minimum for CVT			
Reverse			

4.7. **Maximum vehicle design speed** (in km/h) (<sup>9</sup>)

4.9. **Tachograph:** yes/no (<sup>1</sup>)

4.9.1 *Approval mark:* ...

[<sup>F14</sup>4.11. Gear shift indicator (GSI)

4.11.1. Acoustic indication available yes/no (<sup>1</sup>). If yes, description of sound and sound level at the driver's ear in dB(A). (Acoustic indication always switchable on/off)

4.11.2. Information according to point 4.6 of Annex I to Regulation (EU) No 65/2012 (determined at type-approval)]

## 5. AXLES

- 5.1. Description of each axle: ...
- 5.2. Make: ...
- 5.3. Type: ...
- 5.4. Position of retractable axle(s): ...
- 5.5. Position of loadable axle(s): ...

## 6. SUSPENSION

- 6.2. Type and design of the suspension of each axle or wheel: ...
  - 6.2.1. Level adjustment: yes/no/optional <sup>(1)</sup>
  - 6.2.3. Air-suspension for driving axle(s): yes/no <sup>(1)</sup>
    - 6.2.3.1. Suspension of driving axle equivalent to air-suspension: yes/no <sup>(1)</sup>
  - 6.2.4. Air-suspension for non-driving axle(s): yes/no <sup>(1)</sup>
    - 6.2.4.1. Suspension of non-driving axle(s) equivalent to air-suspension: yes/no <sup>(1)</sup>
- 6.6.1. Tyre/wheel combination(s)
  - (a) for tyres indicate size designation, load-capacity index, speed category symbol, rolling resistance in accordance with ISO 28580 (where applicable) <sup>(1)</sup>;
  - (b) for wheels indicate rim size(s) and off-set(s)
- 6.6.1.1. Axles
  - 6.6.1.1.1. Axle 1: ...
  - 6.6.1.1.2. Axle 2: ...
  - etc.
- 6.6.1.2. Spare wheel, if any: ...
- 6.6.2. Upper and lower limits of rolling radii
  - 6.6.2.1. Axle 1: ...
  - 6.6.2.2. Axle 2: ...
  - etc.

## 7. STEERING

- 7.2. Transmission and control
  - 7.2.1. Type of steering transmission (specify for front and rear, if applicable): ...
  - 7.2.2. Linkage to wheels (including other than mechanical means; specify for front and rear, if applicable): ...
  - 7.2.3. Method of assistance, if any: ...

---

*Status: EU Directives are being published on this site to aid cross referencing from UK legislation. After IP completion day (31 December 2020 11pm) no further amendments will be applied to this version.*

---

8. BRAKES

- 8.5. Anti-lock braking system: yes/no/optional <sup>(1)</sup>
- 8.9. Brief description of the braking system according to item 1.6 of the Addendum to Appendix 1 of Annex IX to Directive 71/320/EEC: ...

- 8.11. Particulars of the type(s) of endurance braking system(s): ...

9. BODYWORK

- 9.1. Type of bodywork using the codes set out in Part C of Annex II: ...

- 9.3. Occupant doors, latches and hinges

- 9.3.1. Door configuration and number of doors: ...

- 9.9. Devices for indirect vision

- 9.9.1. Rear-view mirrors, stating, for each rear-view mirror:

- 9.9.1.1. Make: ...

- 9.9.1.2. Type-approval mark: ...

- 9.9.1.3. Variant: ...

- 9.9.1.6. Optional equipment which may affect the rearward field of vision: ...

- 9.9.2. Devices for indirect vision other than mirrors: ...

- 9.9.2.1. Type and description of the device: ...

- 9.10. Interior arrangement

- 9.10.3. Seats

- 9.10.3.1. Number of seating positions <sup>(8)</sup>: ...

- 9.10.3.1.1. Location and arrangement: ...

- 9.10.3.2. Seat(s) designated for use only when the vehicle is stationary: ...

- 9.10.4.1. Type(s) of head restraints: integrated/detachable/separate <sup>(1)</sup>

- 9.10.4.2. Type-approval number(s), if available: ...

- 9.10.8. Gas used as refrigerant in the air-conditioning system: ...

- 9.10.8.1. The air-conditioning system is designed to contain fluorinated greenhouse gases with a global warming potential higher than 150: yes/no <sup>(1)</sup>

- 9.12.2. Nature and position of supplementary restraint systems (indicate yes/no/optional):

---

(L = left-hand side, R = right-hand side, C = centre)

	Front airbag	Side airbag	Belt pre-loading device
--	--------------	-------------	-------------------------

**a** The table may be extended as necessary for vehicles with more than two rows of seats or if there are more than three seats across the width of the vehicle.

---

*Status: EU Directives are being published on this site to aid cross referencing from UK legislation. After IP completion day (31 December 2020 11pm) no further amendments will be applied to this version.*

First row of seats	L			
	C			
	R			
Second row of seats <sup>a</sup>	L			
	C			
	R			

**a** The table may be extended as necessary for vehicles with more than two rows of seats or if there are more than three seats across the width of the vehicle.

### 9.17. Statutory plates

9.17.1. Photographs and/or drawings of the locations of the statutory plates and inscriptions and of the vehicle identification number: ...

9.17.2. Photographs and/or drawings of the statutory plate and inscriptions (completed example with dimensions): ...

9.17.3. Photographs and/or drawings of the vehicle identification number (completed example with dimensions): ...

9.17.4.1. The meaning of characters in the second section and, if applicable, in the third section used to comply with the requirements of section 5.3 of ISO Standard 3779-1983 shall be explained: ...

9.17.4.2. If characters in the second section are used to comply with the requirements of section 5.4 of ISO Standard 3779-1983, these characters shall be indicated: ...

### 9.22. Front under-run protection

9.22.0. Presence: yes/no/incomplete <sup>(1)</sup>

### 9.23. Pedestrian protection

9.23.1. A detailed description, including photographs and/or drawings, of the vehicle with respect to the structure, the dimensions, the relevant reference lines and the constituent materials of the frontal part of the vehicle (interior and exterior), including detail of any active protection system installed

### [<sup>F15</sup>9.24. Frontal protection systems

9.24.1. General arrangement (drawings or photographs) indicating the position and attachment of the frontal protection systems:

9.24.3. Complete details of fittings required and full instructions, including torque requirements, for fitting:]

## 11. CONNECTIONS BETWEEN TOWING VEHICLES AND TRAILERS AND SEMI-TRAILERS

11.1. Class and type of the coupling device(s) fitted or to be fitted: ...

11.3. Instructions for attachment of the coupling type to the vehicle and photographs or drawings of the fixing points at the vehicle as stated by the manufacturer; additional

---

*Status: EU Directives are being published on this site to aid cross referencing from UK legislation. After IP completion day (31 December 2020 11pm) no further amendments will be applied to this version.*

---

- information, if the use of the coupling type is restricted to certain variants or versions of the vehicle type: ...
- 11.4. Information of the fitting of special towing brackets or mounting plates: ...
- 11.5. Type-approval number(s): ...
12. MISCELLANEOUS
- 12.7.1. Vehicle equipped with a 24 GHz short-range radar equipment: yes/no <sup>(1)</sup>
13. SPECIAL PROVISIONS FOR BUSES AND COACHES
- 13.1. **Class of vehicle:** Class I/Class II/Class III/Class A/Class B <sup>(1)</sup>
- 13.1.2. Chassis types where the type-approved bodywork can be installed (manufacturer(s), and vehicle(s) types): ...
- 13.3. **Number of passengers** (seated and standing)
- 13.3.1. Total (N): ...
- 13.3.2. Upper deck (N<sub>a</sub>) <sup>(1)</sup>: ...
- 13.3.3. Lower deck (N<sub>b</sub>) <sup>(1)</sup>: ...
- 13.4. **Number of passengers** (seated)
- 13.4.1. Total (A): ...
- 13.4.2. Upper deck (A<sub>a</sub>) <sup>(1)</sup>: ...
- 13.4.3. Lower deck (A<sub>b</sub>) <sup>(1)</sup>: ...
- 13.4.4. Number of wheelchair positions for category M<sub>2</sub> and M<sub>3</sub> vehicles: ...
16. ACCESS TO VEHICLE REPAIR AND MAINTENANCE INFORMATION
- 16.1. Address of principal website for access to vehicle repair and maintenance information: ...
- B. Category O
0. GENERAL
- 0.1. Make (trade name of manufacturer): ...
- 0.2. Type: ...
- 0.2.1. Commercial name(s) (if available): ...
- 0.3. Means of identification of type, if marked on the vehicle <sup>(b)</sup>: ...
- 0.3.1. Location of that marking: ...
- 0.4. Category of vehicle <sup>(c)</sup>: ...
- 0.4.1. Classification(s) according to the dangerous goods which the vehicle is intended to transport: ...



- [<sup>F3</sup>0.5. Company name and address of manufacturer: ...]
- 0.8. Name(s) and address(es) of assembly plant(s): ...
- 0.9. Name and address of the manufacturer's representative (if any): ...
1. GENERAL CONSTRUCTION CHARACTERISTICS OF THE VEHICLE
- 1.1. Photographs and/or drawings of a representative vehicle: ...
- 1.3. Number of axles and wheels: ...
- 1.3.1. Number and position of axles with twin wheels: ...
- 1.3.2. Number and position of steered axles: ...
- 1.4. Chassis (if any) (overall drawing): ...
- [<sup>F4</sup>1.9. Specify if the towing vehicle is intended to tow semi-trailers or other trailers and, if the trailer is a semi-, drawbar-, centre-axle- or rigid drawbar trailer: ...]
- 1.10. Specify if the vehicle is specially designed for the controlled-temperature carriage of goods: ...]
- [<sup>F3</sup>2. MASSES AND DIMENSIONS (<sup>f</sup>)(<sup>g</sup>)(<sup>7</sup>)  
(in kg and mm) (Refer to drawing where applicable)]
- 2.1. Wheelbase(s) (fully loaded) (<sup>g1</sup>):
- 2.1.1. Two-axle vehicles: ...
- 2.1.2. Vehicles with three or more axles
- 2.1.2.1. Axle spacing between consecutive axles going from the foremost to the rearmost axle:  
...
- 2.1.2.2. Total axle spacing: ...
- 2.3.1. Track of each steered axle (<sup>g4</sup>): ...
- 2.3.2. Track of all other axles (<sup>g4</sup>): ...
- 2.4. Range of vehicle dimensions (overall)
- 2.4.1. For chassis without bodywork
- 2.4.1.1. Length (<sup>g5</sup>): ...
- 2.4.1.1.1. Maximum permissible length: ...
- 2.4.1.1.2. Minimum permissible length: ...
- 2.4.1.1.3. In the case of trailers, maximum permissible drawbar length (<sup>g6</sup>): ...
- 2.4.1.2. Width (<sup>g7</sup>): ...
- 2.4.1.2.1. Maximum permissible width: ...
- 2.4.1.2.2. Minimum permissible width: ...

---

*Status: EU Directives are being published on this site to aid cross referencing from UK legislation. After IP completion day (31 December 2020 11pm) no further amendments will be applied to this version.*

---

- 2.4.2. For chassis with bodywork
  - 2.4.2.1. Length <sup>(g5)</sup>: ...
    - 2.4.2.1.1. Length of the loading area: ...
    - 2.4.2.1.2. In the case of trailers, maximum permissible drawbar length <sup>(g6)</sup>: ...
  - 2.4.2.2. Width <sup>(g7)</sup>: ...
    - 2.4.2.2.1. Thickness of the walls (in the case of vehicles designed for controlled-temperature transport of goods): ...
  - 2.4.2.3. Height (in running order) <sup>(g8)</sup> (for suspension adjustable for height, indicate normal running position): ...
- [<sup>F3</sup>2.6. **Mass in running order** <sup>(h)</sup>
  - (a) minimum and maximum for each variant: ...
  - (b) mass of each version (a matrix must be provided): ...
- 2.6.1. Distribution of this mass among the axles and, in the case of a semi-trailer a rigid drawbar trailer or a centre-axle trailer, the mass on the coupling: ...
  - (a) minimum and maximum for each variant: ...
  - (b) mass of each version (a matrix must be provided): ...]
- [<sup>F4</sup>2.6.2. Mass of the optional equipment (as defined in point (5) of Article 2 of Regulation (EU) No 1230/2012: ...]
- 2.7. **Minimum mass of the completed vehicle** as stated by the manufacturer, in the case of an incomplete vehicle: ...
- 2.8. **Technically permissible maximum laden mass** stated by the manufacturer <sup>(i)</sup><sup>(3)</sup>: ...
  - 2.8.1. Distribution of this mass among the axles, and in the case of a semi-trailer or centre-axle trailer, load on the coupling point <sup>(3)</sup>: ...
- 2.9. **Technically permissible maximum mass on each axle**: ...
- [<sup>F3</sup>2.10. **Technically permissible mass on each group of axles**: ...]
- [<sup>F3</sup>2.12. **Technically permissible maximum mass at the coupling point**:
  - 2.12.2. Of a semi-trailer, a centre-axle trailer or a rigid drawbar trailer: ...]
- [<sup>F3</sup>2.16. **Registration/in service maximum permissible masses (optional)**
  - 2.16.1. Registration/in service maximum permissible laden mass: ...
  - 2.16.2. Registration/in service maximum permissible mass on each axle and, in the case of a semi-trailer or centre-axle trailer, intended load on the coupling point stated by the manufacturer if lower than the technically permissible maximum mass on the coupling point: ...
  - 2.16.3. Registration/in service maximum permissible mass on each group of axles: ...]

2.16.4. Intended registration/in service maximum permissible towable mass (several entries possible for each technical configuration <sup>(5)</sup>): ...

<sup>F19</sup>2.16.5.....

#### Textual Amendments

**F19** Deleted by Commission Regulation (EU) No 1230/2012 of 12 December 2012 implementing Regulation (EC) No 661/2009 of the European Parliament and of the Council with regard to type-approval requirements for masses and dimensions of motor vehicles and their trailers and amending Directive 2007/46/EC of the European Parliament and of the Council (Text with EEA relevance).

#### 4. TRANSMISSION

4.7. Maximum vehicle design speed (in km/h) <sup>(4)</sup>

#### 5. AXLES

5.1. Description of each axle: ...

5.2. Make: ...

5.3. Type: ...

5.4. Position of retractable axle(s): ...

5.5. Position of loadable axle(s): ...

#### 6. SUSPENSION

6.2. Type and design of the suspension of each axle or wheel: ...

6.2.1. Level adjustment: yes/no/optional <sup>(1)</sup>

6.2.4. Air-suspension for non-driving axle(s): yes/no <sup>(1)</sup>

6.2.4.1. Suspension of non-driving axle(s) equivalent to air-suspension: yes/no <sup>(1)</sup>

6.6.1. Tyre/wheel combination(s)

(a) for tyres indicate size designation, load-capacity index, speed category symbol, rolling resistance in accordance with ISO 28580 (where applicable) <sup>(1)</sup>;

(b) for wheels indicate rim size(s) and off-set(s)

6.6.1.1. *Axles*

6.6.1.1.1. Axle 1: ...

6.6.1.1.2. Axle 2: ...

etc.

6.6.1.2. Spare wheel, if any: ...

6.6.2. Upper and lower limit of rolling radii

6.6.2.1. Axle 1: ...

---

*Status: EU Directives are being published on this site to aid cross referencing from UK legislation. After IP completion day (31 December 2020 11pm) no further amendments will be applied to this version.*

---

6.6.2.2. Axle 2: ...

etc.

7. STEERING

7.2. Transmission and control

7.2.1. Type of steering transmission (specify for front and rear, if applicable): ...

7.2.2. Linkage to the wheels (including other than mechanical means; specify for front and rear, if applicable): ...

7.2.3. Method of assistance, if any: ...

8. BRAKES

8.5. Antilock braking system: yes/no/optional (<sup>1</sup>)

8.9. Brief description of the braking system, according to item 1.6 of the addendum to Appendix 1 of Annex IX to Directive 71/320/EEC: ...

9. BODYWORK

9.1. Type of bodywork using the codes defined in Part C of Annex II: ...

9.17.1. Photographs and/or drawings of the locations of the statutory plates and inscriptions and of the vehicle identification number: ...

9.17.2. Photographs and/or drawings of the statutory plate and inscriptions (completed example with dimensions): ...

9.17.3. Photographs and/or drawings of the vehicle identification number (completed example with dimensions): ...

9.17.4.1. The meaning of characters in the second section and, if applicable, in the third section used to comply with the requirements of section 5.3 of ISO Standard 3779-1983 shall be explained: ...

9.17.4.2. If characters in the second section are used to comply with the requirements of section 5.4 of ISO Standard 3779-1983 these characters shall be indicated: ...

11. CONNECTIONS BETWEEN TOWING VEHICLES AND TRAILERS AND SEMI-TRAILERS

11.1. Class and type of the coupling device(s) fitted or to be fitted: ...

11.5. Type-approval number(s): ...

## PART II

### Matrix showing the combinations of the entries listed in Part I within the versions and variants of the vehicle type

Item No	All	Version 1	Version 2	Version 3	Version n

Notes:

---

**Status:** EU Directives are being published on this site to aid cross referencing from UK legislation. After IP completion day (31 December 2020 11pm) no further amendments will be applied to this version.

---

- (a) A separate matrix shall be compiled for each variant within the type.
- (b) Entries for which there are no restrictions on their combination within a variant shall be listed in the column headed 'all'.
- (c) The above information may be presented in an alternative layout or merged with the information supplied in Part I.
- (d) Each variant and each version shall be identified by an alphanumerical code consisting of a combination of letters and numbers, which shall also be indicated in the certificate of conformity (Annex IX) of the vehicle concerned.
- (e) Variant(s) which fall(s) under Annex XI shall be identified by a specific alphanumerical code.

### PART III

#### Type-approval numbers

Supply the information required by the following table in respect of the applicable subjects for this vehicle in Annex IV or Annex XI. (All relevant approvals for each subject shall be included. However, information in respect of components need not be given here so long as such information is included in the approval certificate relating to the installation prescriptions).

<b>Subject</b>	<b>Type-approval number or test report number<sup>c</sup></b>	<b>Member State or Contracting Party<sup>a</sup> issuing the type-approval<sup>b</sup> or test report<sup>c</sup></b>	<b>Extension date</b>	<b>Variant(s)/version(s)</b>

**a** Contracting Parties to the Revised 1958 Agreement.

**b** To be indicated if not obtainable from the type-approval number.

**c** To be indicated when the manufacturer applies the provisions of Article 9(6). In such a case, the applied regulatory act shall be specified in the second column.

Signed: ...

Position in company: ...

Date: ...]



*Status: EU Directives are being published on this site to aid cross referencing from UK legislation. After IP completion day (31 December 2020 11pm) no further amendments will be applied to this version.*

	protection (RUP)											
4	Rear registration plate space	Directive 70/222/EEC	X	X	X	X	X	X	X	X	X	X
4A	Space for mounting and fixing rear registration plates	Regulation (EC) No 661/2009 Regulation (EU) No 1003/2010	X	X	X	X	X	X	X	X	X	X
5	Steering effort	Directive 70/311/EEC	X	X	X	X	X	X	X	X	X	X
5A	Steering equipment	Regulation (EC) No 661/2009 UNECE Regulation No 79	X	X	X	X	X	X	X	X	X	X
6	Door latches and hinges	Directive 70/387/EEC			X	X	X					
I <sup>F2</sup> 6A	Vehicle access and manoeuvres (steps, running boards and handholds)	Regulation (EC) No 661/2009 Regulation (EU) No 130/2012			X	X	X					I
6B	Door latches and door retention components	Regulation (EC) No 661/2009 UNECE Regulation No 11			X							





**Status:** EU Directives are being published on this site to aid cross referencing from UK legislation. After IP completion day (31 December 2020 11pm) no further amendments will be applied to this version.

		No 661/2009 UNECE Regulation No 10									
12	Interior fittings	Directive 74/60/EEC	X								
12A	Interior fittings	Regulation (EC) No 661/2009 UNECE Regulation No 21	X								
13	Anti-theft and immobiliser	Directive 74/61/EEC	X	X	X	X	X				
13A	Protection of motor vehicle against unauthorised use	Regulation (EC) No 661/2009 UNECE Regulation No 18	X <sup>e</sup>	X <sup>e</sup>		X <sup>e</sup>	X <sup>e</sup>				
13B	Protection of motor vehicle against unauthorised use	Regulation (EC) No 661/2009 UNECE Regulation No 116	X			X					
14	Protection steering	Directive 74/297/EEC	X			X					
14A	Protection of the driver against the steering mechanism in the event	Regulation (EC) No 661/2009 UNECE Regulation No 12	X			X					

*Status: EU Directives are being published on this site to aid cross referencing from UK legislation. After IP completion day (31 December 2020 11pm) no further amendments will be applied to this version.*

	of impact										
15	Seat strength	Directive 74/408/EEC	X	X	X	X	X				
15A	Seats, their anchorages and any head restraint	Regulation (EC) No 661/2009 UNECE Regulation No 17	X <sup>r</sup>	X <sup>r</sup>	X	X	X				
15B	Seats of large passenger vehicles	Regulation (EC) No 661/2009 UNECE Regulation No 80	X	X							
16	Exterior projections	Directive 74/483/EEC									
16A	External projections	Regulation (EC) No 661/2009 UNECE Regulation No 26									
17	Speedo and reverse gear	Directive 75/443/EEC	X	X	X	X	X				
[ <sup>F2</sup> 17A	Vehicle access and manoeuvring (reverse gear)	Regulation (EC) No 661/2009 UNECE Regulation (EU) No 130/2012	X	X	X	X	X				I
17B	Speedo equipment including	Regulation (EC) No 661/2009	X	X	X	X	X				



*Status: EU Directives are being published on this site to aid cross referencing from UK legislation. After IP completion day (31 December 2020 11pm) no further amendments will be applied to this version.*

21A	Retro-reflecting devices for power-driven vehicles and their trailers	Regulation (EC) No 661/2009 UNECE Regulation No 3	X	X	X	X	X	X	X	X	X	X
22	End-outline front-position (side), rear-position (side), stop, side marker, daytime running lamps	Directive 76/758/EEC	X	X	X	X	X	X	X	X	X	X
22A	Front and rear position lamps, stop-lamps and end-outline marker lamps for motor vehicles and their trailers	Regulation (EC) No 661/2009 UNECE Regulation No 7	X	X	X	X	X	X	X	X	X	X
22B	Daytime running lamps for power-driven vehicles	Regulation (EC) No 661/2009 UNECE Regulation No 87	X	X	X	X	X					

*Status: EU Directives are being published on this site to aid cross referencing from UK legislation. After IP completion day (31 December 2020 11pm) no further amendments will be applied to this version.*

22C	Side-marker lamps for motor vehicles and their trailers	Regulation (EC) No 661/2009 UNECE Regulation No 91	X	X	X	X	X	X	X	X	X	X
23	Directional indicators	Directive 76/759/EEC	X	X	X	X	X	X	X	X	X	X
23A	Directional indicators for power-driven vehicles and their trailers	Regulation (EC) No 661/2009 UNECE Regulation No 6	X	X	X	X	X	X	X	X	X	X
24	Rear registration plate lamps	Directive 76/760/EEC	X	X	X	X	X	X	X	X	X	X
24A	Illumination of rear-registration plates of power-driven vehicles and their trailers	Regulation (EC) No 661/2009 UNECE Regulation No 4	X	X	X	X	X	X	X	X	X	X
25	Headlamps (including bulbs)	Directive 76/761/EEC	X	X	X	X	X					
25A	Power-driven vehicle sealed-beam headlamps (SB) emitting an	Regulation (EC) No 661/2009 UNECE Regulation No 31	X	X	X	X	X					

*Status: EU Directives are being published on this site to aid cross referencing from UK legislation. After IP completion day (31 December 2020 11pm) no further amendments will be applied to this version.*

	European asymmetrical passing beam or a driving beam or both											
25B	Filament lamps for use in approved lamp units of power-driven vehicles and their trailers	Regulation (EC) No 661/2009 UNECE Regulation No 37	X	X	X	X	X	X	X	X	X	X
25C	Motor vehicle headlamps equipped with gas-discharge light sources	Regulation (EC) No 661/2009 UNECE Regulation No 98	X	X	X	X	X					
25D	Gas-discharge light sources for use in approved gas-discharge lamp units of power-driven vehicles	Regulation (EC) No 661/2009 UNECE Regulation No 99	X	X	X	X	X					
25E	Motor vehicle	Regulation (EC)	X	X	X	X	X					

*Status: EU Directives are being published on this site to aid cross referencing from UK legislation. After IP completion day (31 December 2020 11pm) no further amendments will be applied to this version.*

	headlamps emitting an asymmetric passing beam or a driving beam or both and equipped with filament lamps and/or LED modules	No 661/2009 UNECE Regulation No 112									
25F	Adaptive front-lighting systems (AFS) for motor vehicles	Regulation (EC) No 661/2009 UNECE Regulation No 123	X	X	X	X	X				
26	Front fog lamps	Directive 76/762/EEC	X	X	X	X	X				
26A	Power driven front fog lamps	Regulation (EC) No 661/2009 UNECE Regulation No 19	X	X	X	X	X				
27	Towing hooks	Directive 77/389/EEC	X	X	X	X	X				
27A	Towing device	Regulation (EC) No 661/2009 Regulation (EU) No 1005/2010	X	X	X	X	X				

*Status: EU Directives are being published on this site to aid cross referencing from UK legislation. After IP completion day (31 December 2020 11pm) no further amendments will be applied to this version.*

28	Rear fog lamps	Directive 77/538/EEC	X	X	X	X	X	X	X	X	X	X
28A	Rear fog lamps for power-driven vehicles and their trailers	Regulation (EC) No 661/2009 UNECE Regulation No 38	X	X	X	X	X	X	X	X	X	X
29	Reversing lamps	Directive 77/539/EEC	X	X	X	X	X	X	X	X	X	X
29A	Reversing lights for power-driven vehicles and their trailers	Regulation (EC) No 661/2009 UNECE Regulation No 23	X	X	X	X	X	X	X	X	X	X
30	Parking lamps	Directive 77/540/EEC	X	X	X	X	X					
30A	Parking lamps for power-driven vehicles	Regulation (EC) No 661/2009 UNECE Regulation No 77	X	X	X	X	X					
31	Seat belts and restraint systems	Directive 77/541/EEC	X	X	X	X	X					
31A	Safety belts, restraint systems, child restraint systems and	Regulation (EC) No 661/2009 UNECE Regulation No 16	X	X	X	X	X					



*Status: EU Directives are being published on this site to aid cross referencing from UK legislation. After IP completion day (31 December 2020 11pm) no further amendments will be applied to this version.*

	Isofix child restraint systems											
32	Forward vision	Directive 77/649/EEC	X									
32A	Forward field of vision	Regulation (EC) No 661/2009 UNECE Regulation No 125	X									
33	Identification of control tell-tales and indicators	Directive 78/316/EEC	X	X	X	X	X					
33A	Location and identification of hand control tell-tales and indicators	Regulation (EC) No 661/2009 UNECE Regulation No 121	X	X	X	X	X					
34	Defrost demist	Directive 78/317/EEC	g	g	g	g	g					
34A	Windscreens defrosting and demisting systems	Regulation (EC) No 661/2009 Regulation (EU) No 672/2010	g	g	g	g	g					
35	Wash/wipe	Directive 78/318/EEC	h	h	h	h	h					
35A	Windscreens wiper	Regulation (EC)	h	h	h	h	h					

*Status: EU Directives are being published on this site to aid cross referencing from UK legislation. After IP completion day (31 December 2020 11pm) no further amendments will be applied to this version.*

	and washer systems	No 661/2009 Regulation (EU) No 1008/2010										
36	Heating systems	Directive 2001/56/EC	X	X	X	X	X	X	X	X	X	X
36A	Heating systems	Regulation (EC) No 661/2009 UNECE Regulation No 122	X	X	X	X	X	X	X	X	X	X
37	Wheel guards	Directive 78/549/EEC										
37A	Wheel guards	Regulation (EC) No 661/2009 Regulation (EU) No 1009/2010										
38	Head restraints	Directive 78/932/EEC										
[ <sup>F17</sup> 38A	Head restraints (headrests), whether or not incorporated in vehicle seats	Regulation (EC) No 661/2009 UNECE Regulation No 25										]
[ <sup>F21</sup>												
F21]												
41A	Emission (Euro VI) heavy duty	Regulation (EC) No 595/2009	X <sup>k</sup>	X	X <sup>k</sup>	X <sup>k</sup>	X					





*Status: EU Directives are being published on this site to aid cross referencing from UK legislation. After IP completion day (31 December 2020 11pm) no further amendments will be applied to this version.*

	and C3)											
46E	Temporary use spare unit, run-flat tyres/ system and tyre pressure monitoring system	Regulation (EC) No 661/2009 UNECE Regulation No 64				X <sup>1</sup>						
47	Speed limitation devices	Directive 91/24/EEC	X	X			X	X				
47A	Speed limitation of vehicles	Regulation (EC) No 661/2009 UNECE Regulation No 89	X	X			X	X				
48	Masses and dimensions (other than vehicles referred to in item 44)	Directive 97/27/EC	X	X	X	X	X	X	X	X	X	X
48A	Masses and dimensions	Regulation (EC) No 661/2009 Regulation (EU) No 1230/2012	X	X	X	X	X	X	X	X	X	X
49	External projections of cabs	Directive 2011/4/EEC				X	X	X				

*Status: EU Directives are being published on this site to aid cross referencing from UK legislation. After IP completion day (31 December 2020 11pm) no further amendments will be applied to this version.*

49A	Commercial vehicles (EC) with regard to their external projections forward of the cab's rear panel	Regulation (EC) No 661/2009 UNECE Regulation No 118			X	X	X				
50	Coupling	Directive 94/20/EC	X <sup>m</sup>	X <sup>m</sup>	X <sup>m</sup>	X <sup>m</sup>	X <sup>m</sup>	X	X	X	X
50A	Mechanical coupling components of combination of vehicles	Regulation (EC) No 661/2009 UNECE Regulation No 55	X <sup>m</sup>	X <sup>m</sup>	X <sup>m</sup>	X <sup>m</sup>	X <sup>m</sup>	X	X	X	X
50B	Close-coupling device (CCD) fitting of an approved type of CCD	Regulation (EC) No 661/2009 UNECE Regulation No 102				X <sup>m</sup>	X <sup>m</sup>			X <sup>m</sup>	X <sup>m</sup>
51	Flammable	Directive 95/28/EC		X							
51A	Burning behaviour of materials used in the interior construction of certain categories of	Regulation (EC) No 661/2009 UNECE Regulation No 118		X							







*Status: EU Directives are being published on this site to aid cross referencing from UK legislation. After IP completion day (31 December 2020 11pm) no further amendments will be applied to this version.*

64	Gear shift indicators	Regulation (EC) No 661/2009 Regulation (EU) No 65/2012	X								
65	Advanced emergency braking system	Regulation (EC) No 661/2009 Regulation (EU) No 347/2012	X	X		X	X				
66	Lane departure warning system	Regulation (EC) No 661/2009 Regulation (EU) No 351/2012	X	X		X	X				
67	Specific components for liquefied petroleum gases (LPG) and their installation on motor vehicles	Regulation (EC) No 661/2009 UNECE Regulation No 67	X	X	X	X	X				
68	Vehicle alarm systems (VAS)	Regulation (EC) No 661/2009 UNECE Regulation No 97			X						
69	Electrical safety	Regulation (EC) No 661/2009	X	X	X	X	X				

*Status: EU Directives are being published on this site to aid cross referencing from UK legislation. After IP completion day (31 December 2020 11pm) no further amendments will be applied to this version.*

		UNECE Regulation No 100									
70	Specific component for CNG and their installation on motor vehicles	Regulation (EC) No 661/2009 UNECE Regulation No 110	X	X	X	X	X				
[ <sup>F22</sup> 71]	Cab strengthening	Regulation (EC) No 661/2009 UNECE Regulation No 29			X	X	X				l
<b>a</b>	For vehicles with a reference mass not exceeding 2 610 kg. At the manufacturer's request, may apply to vehicles with a reference mass not exceeding 2 840 kg.										
<b>b</b>	In case of vehicles equipped with a LPG or CNG installation, a vehicle type-approval in accordance with UNECE Regulation No 67 or UNECE Regulation No 110 is required.										
<b>c</b>	The fitting of an electronic stability control ('ESC') system is required in accordance with Article 12 of Regulation (EC) No 661/2009. Therefore, the requirements set out in Annex 21 to UNECE Regulation 13 shall be complied with for the purposes of EC type-approval of new types of vehicles as well as for the registration, sale and entry into service of new vehicles. The implementation dates set out in Article 13 of Regulation (EC) No 661/2009 shall apply instead of the dates set out in UNECE Regulation No 13.										
<b>d</b>	The fitting of an ESC system is required in accordance with Article 12 of Regulation (EC) No 661/2009. Therefore, the requirements set out in Part A of Annex 9 to UNECE Regulation No 13-H shall be complied with for the purposes of EC type-approval of new types of vehicles as well as for the registration, sale and entry into service of new vehicles. The implementation dates set out in Article 13 Regulation (EC) No 661/2009 shall apply instead of the dates set out in UNECE Regulation No 13-H.										
<b>e</b>	(4A) If fitted, the protective device shall fulfil the requirements of UNECE Regulation No 18.										
<b>f</b>	(4B) This Regulation applies to seats not falling within the scope of UNECE Regulation No 80.										
<b>g</b>	Vehicles of this category shall be fitted with a suitable windscreen defrosting and demisting device.										
<b>h</b>	Vehicles of this category shall be fitted with a suitable windscreen washing and wiping devices.										
<b>i</b>	[ <sup>F21</sup>										
<b>j</b>	] <sup>F21</sup>										
<b>k</b>	For vehicles with a reference mass exceeding 2 610 kg which are not type-approved (at the manufacturer's request and provided their reference mass does not exceed 2 840 kg) under Regulation (EC) No 715/2007. For other options, see Article 2 of Regulation (EC) No 595/2009.										
<b>l</b>	(9A) Applies only where such vehicles are fitted with equipment covered by UNECE Regulation No 64. Tyre pressure monitoring system for M1 vehicles applies on a compulsory basis in accordance with Article 9(2) of Regulation (EC) No 661/2009.										
<b>m</b>	Applies only to vehicles equipped with coupling(s).										
<b>n</b>	Applies to vehicles with a technically permissible maximum laden mass not exceeding 2,5 tonnes.										

**Status:** EU Directives are being published on this site to aid cross referencing from UK legislation. After IP completion day (31 December 2020 11pm) no further amendments will be applied to this version.

- o** Only applicable to vehicles where the ‘Seating Reference Point (“R” point)’ of the lowest seat is not more than 700 mm above the ground level.
- p** Applies only when the manufacturer applies for type-approval of vehicles intended for the transport of dangerous goods.
- q** Applies only for vehicles of category N<sub>1</sub>, class I as described in the first table in point 5.3.1.4 of Annex I to Directive 70/220/EEC.
- r** [F<sup>2</sup>Compliance with Regulation (EC) No 661/2009 is mandatory, however, type-approval under this single item is not provided for as the item covers the combination of individual items 3A, 3B, 4A, 5A, 6A, 6B, 7A, 8A, 9A, 9B, 10A, 12A, 13A, 13B, 14A, 15A, 15B, 16A, 17A, 17B, 18A, 19A, 20A, 21A, 22A, 22B, 22C, 23A, 24A, 25A, 25B, 25C, 25D, 25E, 25F, 26A, 27A, 28A, 29A, 30A, 31A, 32A, 33A, 34A, 35A, 36A, 37A, 38A, 42A, 43A, 44A, 45A, 46A, 46B, 46C, 46D, 46E, 47A, 48A, 49A, 50A, 50B, 51A, 52A, 52B, 53A, 54A, 56A, 57A and 64 to 71.]

Explanatory notes:

XRegulatory act applicable.

Note: The series of amendments of the UNECE Regulations which apply on a compulsory basis are listed in Annex IV to Regulation (EC) No 661/2009. Series of amendments adopted subsequently are accepted as an alternative.]

### Textual Amendments

- F21** Deleted by Regulation (EC) No 595/2009 of the European Parliament and of the Council of 18 June 2009 on type-approval of motor vehicles and engines with respect to emissions from heavy duty vehicles (Euro VI) and on access to vehicle repair and maintenance information and amending Regulation (EC) No 715/2007 and Directive 2007/46/EC and repealing Directives 80/1269/EEC, 2005/55/EC and 2005/78/EC (Text with EEA relevance).
- F22** Inserted by Commission Regulation (EU) 2015/166 of 3 February 2015 supplementing and amending Regulation (EC) No 661/2009 of the European Parliament and of the Council as regards the inclusion of specific procedures, assessment methods and technical requirements, and amending Directive 2007/46/EC of the European Parliament and of the Council, and Commission Regulations (EU) No 1003/2010, (EU) No 109/2011 and (EU) No 458/2011 (Text with EEA relevance).

### [F<sup>20</sup> Appendix 1

#### Regulatory acts for EC type-approval of vehicles produced in small series pursuant to Article 22

1. This Appendix applies to new EC type-approvals of small series granted from 1 November 2012, except for item 54A which applies from 1 November 2014.
2. EC type-approvals of small series granted before 1 November 2012 shall cease to be valid on 31 October 2016. National authorities shall consider certificates of conformity for vehicles to be no longer valid for the purposes of Article 26(1) of this Directive, unless the type-approvals concerned have been updated to the requirements of this Appendix.

Table 1

#### M<sub>1</sub> vehicles<sup>a</sup>

Item	Subject	Regulatory act	Specific issues	Applicability and specific requirements
1	Permissible sound level	Directive 70/157/EEC		A
[F <sup>23</sup> 2	Emissions (Euro 5 and 6) light duty	Regulation (EC) No 715/2007		A

*Status: EU Directives are being published on this site to aid cross referencing from UK legislation. After IP completion day (31 December 2020 11pm) no further amendments will be applied to this version.*

Table 1

**M<sub>1</sub> vehicles<sup>a</sup>**

vehicles/access to information	(a)	On-board diagnostic (OBD)	The vehicle shall be fitted with an OBD system that fulfils the requirements of Article 4(1) and (2) of Regulation (EC) No 692/2008 (The OBD system shall be designed to record at least the malfunction of the engine management system). The OBD-interface shall be able to communicate with commonly available diagnostic tools.
	(b)	In service conformity	N/A
	(c)	Access to information	It is sufficient that the manufacturer provide access to repair and maintenance information in a readily accessible and prompt manner.
	(d)	Power measurement	<i>(When the vehicle manufacturer uses an engine from another manufacturer)</i> Bench test data from the engine manufacturer are accepted provided that

*Status: EU Directives are being published on this site to aid cross referencing from UK legislation. After IP completion day (31 December 2020 11pm) no further amendments will be applied to this version.*

Table 1

**M<sub>1</sub> vehicles<sup>a</sup>**

				the engine management system is identical (i.e. having at least the same ECU). Power output test may be performed on a chassis dynamometer. It shall be taken into account of the power loss in the transmission.]	
3A	Prevention of fire risks (liquid fuel tanks)	Regulation (EC) No 661/2009 UNECE Regulation No 34	(a)	Liquid fuel tanks	B
			(b)	Installation in vehicle	B
[ <sup>F18</sup> 3B	Rear underrun protective devices (RUPDs) and their installation; rear underrun protection (RUP)	Regulation (EC) No 661/2009 UNECE Regulation No 58			B]
4A	Space for mounting and fixing rear registration plates	Regulation (EC) No 661/2009 Regulation (EU) No 1003/2010			B
5A	Steering equipment	Regulation (EC) No 661/2009 UNECE Regulation No 79			C
			(a)	Mechanical systems	The provisions of paragraph 5 of UNECE Regulation No 79 shall apply. All tests prescribed in paragraph 6.2 of UNECE Regulation

*Status: EU Directives are being published on this site to aid cross referencing from UK legislation. After IP completion day (31 December 2020 11pm) no further amendments will be applied to this version.*

Table 1

**M<sub>1</sub> vehicles<sup>a</sup>**

				No 79 shall be performed and the requirements of paragraph 6.1 of UNECE Regulation No 79 shall apply.
			(b) Complex electronic vehicle control system	All the requirements of Annex 6 of UNECE Regulation No 79 shall apply. Compliance with these requirements may only be checked by an appointed technical service.
6A	Door latches and door retention components	Regulation (EC) No 661/2009 UNECE Regulation No 11		C
			(a) General requirements (Paragraph 5 of UNECE Regulation No 11)	All the requirements shall apply.
			(b) Performance requirements (Paragraph 6 of UNECE Regulation No 11)	Only the requirements of paragraph 6.1.5.4 and paragraph 6.3 on door locks shall apply.
7A	Audible warning devices and signals	Regulation (EC) No 661/2009 UNECE Regulation No 28	(a) Components	X
			(b) Installation on vehicle	B
8A	Devices for indirect vision and their installation	Regulation (EC) No 661/2009	(a) Components	X

**Status:** EU Directives are being published on this site to aid cross referencing from UK legislation. After IP completion day (31 December 2020 11pm) no further amendments will be applied to this version.

Table 1

**M<sub>1</sub> vehicles<sup>a</sup>**

		UNECE Regulation No 46	(b)	Installation on vehicle	B
9B	Braking	Regulation (EC) No 661/2009 UNECE Regulation No 13-H	(a)	Design and tests requirements	A
			(b)	Electronic stability control (ESC) and brake assist systems (BAS)	The fitting of BAS and ESC shall not be required. If fitted, they shall comply with the requirements of UNECE Regulation No 13-H.
10A	Electromagnetic compatibility	Regulation (EC) No 661/2009 UNECE Regulation No 10			B
12A	Interior fittings	Regulation (EC) No 661/2009 UNECE Regulation No 21			C
			(a)	Interior arrangement	
			(i)	Radii and protrusion requirements for switches, pull-knobs and the like, controls and general interior fittings	The requirements of paragraphs 5.1 to 5.6 of UNECE Regulation No 21 may be waived at the request of the manufacturer. The requirements of paragraph 5.2 of UNECE Regulation No 21 with the exception of paragraphs 5.2.3.1, 5.2.3.2

*Status: EU Directives are being published on this site to aid cross referencing from UK legislation. After IP completion day (31 December 2020 11pm) no further amendments will be applied to this version.*

Table 1

**M<sub>1</sub> vehicles<sup>a</sup>**

				and 5.2.4 shall apply.
			(ii) Energy absorption tests on the upper dashboard	Energy absorption tests on the upper dashboard shall only be performed when the vehicle is not fitted with at least two front airbags or two static four-point harnesses.
			(iii) Energy absorption test on the rear part of the seats	N/A
			(b) Power-operation of windows, roof-panel systems and partition systems	All requirements of paragraph 5.8 UNECE Regulation No 21 shall apply.
[ <sup>F2</sup> 13A	Protection of motor vehicles against unauthorised use	Regulation (EC) No 661/2009 UNECE Regulation No 116		A The provisions of paragraph 8.3.1.1.1 of UNECE Regulation No 116 may be applied instead of paragraph 8.3.1.1.2 of that Regulation regardless of the type of powertrain]



Table 1

**M<sub>1</sub> vehicles<sup>a</sup>**

14A	Protection of the driver against the steering mechanism in the event of impact	Regulation (EC) No 661/2009 UNECE Regulation No 12		C
				Tests are required when the vehicle has not been tested under UNECE Regulation No 94 (see item 53A)
15A	Seats, their anchorages and any head restraints	Regulation (EC) No 661/2009 UNECE Regulation No 17	(a)	C
			(i)	General requirements Specifications Requirements of paragraph 5.2 of UNECE Regulation No 17 shall apply with the exception of paragraph 5.2.3.
			(ii)	Strength tests for seat backrest and head restraints The requirements of paragraph 6.2 UNECE Regulation No 17 shall apply.
			(iii)	Unlocking and adjustment tests The test shall be performed in accordance with the requirements of Annex 7 to UNECE Regulation No 17.
			(b) (i)	Head restraints Specifications Requirements of paragraphs 5.4, 5.5, 5.6, 5.10, 5.11 and 5.12 of UNECE Regulation No 17 shall apply with the exception of paragraph 5.5.2.

*Status: EU Directives are being published on this site to aid cross referencing from UK legislation. After IP completion day (31 December 2020 11pm) no further amendments will be applied to this version.*

Table 1

**M<sub>1</sub> vehicles<sup>a</sup>**

			(ii) Strength tests on head restraints	The test prescribed in paragraph 6.4 shall be performed.
			(c) Special requirements regarding the protection of occupants from displaced luggage	The requirements of Annex 9 to UNECE Regulation No 26 may be waived at the request of the manufacturer.
16A	External projections	Regulation (EC) No 661/2009 UNECE Regulation No 26		C
			(a) General specifications	The requirements of paragraph 5 of UNECE Regulation No 26 shall apply.
			(b) Particular specifications	The requirements of paragraph 6 of UNECE Regulation No 26 shall apply.
17A	Vehicle access and manoeuvrability	Regulation (EC) No 661/2009 Regulation (EU) No 130/2012		D
17B	Speedometer equipment including its installation	Regulation (EC) No 661/2009 UNECE Regulation No 39		B
18A	Manufacturer's statutory plate and vehicle identification number	Regulation (EC) No 661/2009 Regulation (EU) No 19/2011		B
19A	Safety-belt anchorages,	Regulation (EC) No 661/2009		B

*Status: EU Directives are being published on this site to aid cross referencing from UK legislation. After IP completion day (31 December 2020 11pm) no further amendments will be applied to this version.*

Table 1

**M<sub>1</sub> vehicles<sup>a</sup>**

	Isofix anchorages systems and Isofix top tether anchorages	UNECE Regulation No 14		
20A	Installation of lighting and light-signalling devices on vehicles	Regulation (EC) No 661/2009 UNECE Regulation No 48		B Daytime Running Lights (DRL) shall be fitted to a new vehicle type in accordance with Article 2 of Directive 2008/89/EC.
21A	Retro-reflecting devices for power-driven vehicles and their trailers	Regulation (EC) No 661/2009 UNECE Regulation No 3		X
22A	Front and rear position lamps, stop-lamps and end-outline marker lamps for motor vehicles and their trailers	Regulation (EC) No 661/2009 UNECE Regulation No 7		X
22B	Daytime running lamps for power-driven vehicles	Regulation (EC) No 661/2009 UNECE Regulation No 87		X
22C	Side-marker lamps for motor vehicles and their trailers	Regulation (EC) No 661/2009 UNECE Regulation No 91		X
23A	Direction indicators for power-driven vehicles and their trailers	Regulation (EC) No 661/2009 UNECE Regulation No 6		X
24A	Illumination of rear-registration plates of power-	Regulation (EC) No 661/2009 UNECE Regulation No 4		X

*Status: EU Directives are being published on this site to aid cross referencing from UK legislation. After IP completion day (31 December 2020 11pm) no further amendments will be applied to this version.*

Table 1

**M<sub>1</sub> vehicles<sup>a</sup>**

	driven vehicles and their trailers			
25A	Power-driven vehicle's sealed-beam headlamps (SB) emitting an European asymmetrical passing beam or a driving beam or both	Regulation (EC) No 661/2009 UNECE Regulation No 31		X
25B	Filament lamps for use in approved lamp units of power-driven vehicles and their trailers	Regulation (EC) No 661/2009 UNECE Regulation No 37		X
25C	Motor vehicle headlamps equipped with gas-discharge light sources	Regulation (EC) No 661/2009 UNECE Regulation No 98		X
25D	Gas-discharge light sources for use in approved gas-discharge lamp units of power-driven vehicles	Regulation (EC) No 661/2009 UNECE Regulation No 99		X
25E	Motor vehicle headlamps emitting an asymmetrical passing beam or a driving beam or both and equipped with filament lamps and/or LED modules	Regulation (EC) No 661/2009 UNECE Regulation No 112		X
25F	Adaptive front-lighting systems (AFS) for motor vehicles	Regulation (EC) No 661/2009 UNECE Regulation No 123		X

**Status:** EU Directives are being published on this site to aid cross referencing from UK legislation. After IP completion day (31 December 2020 11pm) no further amendments will be applied to this version.

Table 1

**M<sub>1</sub> vehicles<sup>a</sup>**

26A	Power-driven vehicle front fog lamps	Regulation (EC) No 661/2009 UNECE Regulation No 19		X
27A	Towing device	Regulation (EC) No 661/2009 Regulation (EU) No 1005/2010		B
28A	Rear fog lamps for power-driven vehicles and their trailers	Regulation (EC) No 661/2009 UNECE Regulation No 38		X
29A	Reversing lights for power-driven vehicles and their trailers	Regulation (EC) No 661/2009 UNECE Regulation No 23		X
30A	Parking lamps for power-driven vehicles	Regulation (EC) No 661/2009 UNECE Regulation No 77		X
31A	Safety-belts, restraint systems, child restraint systems and Isofix child restraint systems	Regulation (EC) No 661/2009 UNECE Regulation No 16	(a) Components	X
			(b) Installation requirements	B
32A	Forward field of vision	Regulation (EC) No 661/2009 UNECE Regulation No 125		A
33A	Location and identification of hand controls, tell-tales and indicators	Regulation (EC) No 661/2009 UNECE Regulation No 121		A
34A	Windscreen defrosting and demisting systems	Regulation (EC) No 661/2009 Regulation (EU) No 672/2010		C
			(a) Windscreen defrosting	Only paragraph 1.1.1 of Annex 4I to Regulation

*Status: EU Directives are being published on this site to aid cross referencing from UK legislation. After IP completion day (31 December 2020 11pm) no further amendments will be applied to this version.*

Table 1

**M<sub>1</sub> vehicles<sup>a</sup>**

				(EU) No 672/2010 shall apply provided that warm air flow is ducted to the whole surface of the windscreen or the latter is electrically heated on its whole surface.
			(b) Windscreen demisting	Only point 1.2.1 of Annex II to Regulation (EU) No 672/2010 shall apply provided that warm air flow is ducted to the whole surface of the windscreen or the latter is electrically heated on its whole surface.
35A	Windscreen wiper and washer systems	Regulation (EC) No 661/2009 Regulation (EU) No 1008/2010		C
			(a) Windscreen wiper system	Paragraphs 1.1 to 1.1.10 of Annex III to Regulation (EU) No 1008/2010 shall apply. Only the test described in paragraph 2.1.10 of Annex III to Regulation (EU) No 1008/2010 shall be performed.
			(b) Windscreen washer system	Section 1.2 of Annex III to Regulation (EU) No 1008/2010 shall apply with the exception

**Status:** EU Directives are being published on this site to aid cross referencing from UK legislation. After IP completion day (31 December 2020 11pm) no further amendments will be applied to this version.

Table 1

**M<sub>1</sub> vehicles<sup>a</sup>**

				of points 1.2.2, 1.2.3 and 1.2.5.
36A	Heating system	Regulation (EC) No 661/2009 UNECE Regulation No 122		C The fitting of a heating system shall not be required.
			(a)	All heating systems The requirements of paragraph 5.3 and of paragraph 6 of UNECE Regulation No 122 shall apply.
			(b)	LPG heating systems The requirements of Annex 8 to UNECE Regulation No 122 shall apply.
37A	Wheel guards	Regulation (EC) No 661/2009 Regulation (EU) No 1009/2010		B
[ <sup>F18</sup> 38A	Head restraints	Regulation (EC) No 661/2009 UNECE Regulation No 25		X]
[ <sup>F21</sup>				
F21				
F21				
F21]				
[ <sup>F23</sup> 41A	Emissions (Euro VI) heavy duty vehicles/ access to information	Regulation (EC) No 595/2009		A With the exception of the set of requirements relating to OBDs and access to information.
			Power measurement	(When the vehicle

*Status: EU Directives are being published on this site to aid cross referencing from UK legislation. After IP completion day (31 December 2020 11pm) no further amendments will be applied to this version.*

Table 1

**M<sub>1</sub> vehicles<sup>a</sup>**

				<p><i>manufacturer uses an engine from another manufacturer)</i>  Bench test data from the engine manufacturer are accepted provided that the engine management system is identical (i.e. having at least the same ECU). Power output test may be performed on a chassis dynamometer. It shall be taken into account of the power loss in the transmission.]</p>
44A	Masses and dimensions	Regulation (EC) No 661/2009 Regulation (EU) No 1230/2012		B The hill start test at maximum combination mass described in paragraph 5.1 of Part A of Annex 1 to Regulation (EU) No 1230/2012 may be waived at the request of the manufacturer.
45A	Safety glazing materials and their installation on vehicles	Regulation (EC) No 661/2009 UNECE Regulation No 43	(a) Components	X
			(b) Installation	B
46	Tyres	Directive 92/23/EEC	Components	X



**Status:** EU Directives are being published on this site to aid cross referencing from UK legislation. After IP completion day (31 December 2020 11pm) no further amendments will be applied to this version.

Table 1

**M<sub>1</sub> vehicles<sup>a</sup>**

46A	Installation of tyres	Regulation (EC) No 661/2009 Regulation (EU) No 458/2011		B Dates for progressive application shall be those set out in Article 13 of Regulation (EC) No 661/2009.
46B	Pneumatic tyres for motor vehicles and their trailers (Class C1)	Regulation (EC) No 661/2009 UNECE Regulation No 30	Components	X
46D	Tyre rolling sound emissions, adhesion on wet surfaces and rolling resistance (classes C1, C2 and C3)	Regulation (EC) No 661/2009 UNECE Regulation No 117	Components	X
46E	Temporary-use spare unit, run-flat tyres/system and tyre pressure monitoring system	Regulation (EC) No 661/2009 UNECE Regulation No 64	Components	X
			Fitting of a tyre-pressure monitoring system (TPMS)	B The fitting of a TPMS shall not be required.
50A	Mechanical coupling components of combinations of vehicles	Regulation (EC) No 661/2009 UNECE Regulation No 55	(a) Components	X
			(b) Installation	B
53A	Protection of occupants in the event of a frontal collision	Regulation (EC) No 661/2009 UNECE Regulation No 94		C The requirements of UNECE Regulation No 94 shall apply to vehicles fitted with front airbags. Vehicles not fitted with airbags shall fulfil the requirement of item 14A of this table.

*Status: EU Directives are being published on this site to aid cross referencing from UK legislation. After IP completion day (31 December 2020 11pm) no further amendments will be applied to this version.*

Table 1

**M<sub>1</sub> vehicles<sup>a</sup>**

54A	Protection of occupants in the event of lateral collision	Regulation (EC) No 661/2009 UNECE Regulation No 95		C (shall apply from 1 November 2014)
			Head form test	The manufacturer shall supply the technical service with suitable information concerning a possible impact of the head of the dummy against the structure of the vehicle or the side glazing if made up of laminated glazing. When such impact is proven likely to happen, then the partial test using the head form test described in paragraph 3.1 of Annex 8 to UNECE Regulation No 95 shall be conducted and the criterion specified in paragraph 5.2.1.1 of UNECE Regulation 95 shall be met. In agreement with the technical service, the test procedure described in Annex 4 to UNECE

**Status:** EU Directives are being published on this site to aid cross referencing from UK legislation. After IP completion day (31 December 2020 11pm) no further amendments will be applied to this version.

Table 1

**M<sub>1</sub> vehicles<sup>a</sup>**

				Regulation No 21 may be used as an alternative to the test mentioned above.
58	Pedestrian protection	Regulation (EC) No 78/2009	(a)	Technical requirements applicable to vehicle
			(b)	Frontal protection systems
59	Recyclability	Directive 2005/64/EC		N/A Only Article 7 on reuse of component parts shall apply.
61	Air-conditioning systems	Directive 2006/40/EC		A Fluorinated greenhouse gases with a global warming potential higher than 150 are permitted until 31 December 2016.
62	Hydrogen system	Regulation (EC) No 79/2009		X
[ <sup>F2</sup> 63	General Safety	Regulation (EC) No 661/2009		See footnote <sup>0</sup> of the table in Part I of Annex IV with regulatory acts for EC type-approval of vehicles produced in unlimited series]
64	Gear shift indicators	Regulation (EC) No 661/2009 Regulation (EU) No 65/2012		N/A

*Status: EU Directives are being published on this site to aid cross referencing from UK legislation. After IP completion day (31 December 2020 11pm) no further amendments will be applied to this version.*

Table 1

**M<sub>1</sub> vehicles<sup>a</sup>**

67	Specific components for liquefied petroleum gases (LPG) and their installation on motor vehicles	Regulation (EC) No 661/2009 UNECE Regulation No 67	(a)	Components	X
			(b)	Installation	A
68	Vehicle alarm systems (VAS)	Regulation (EC) No 661/2009 UNECE Regulation No 97	(a)	Components	X
			(b)	Installation	B
69	Electric safety	Regulation (EC) No 661/2009 UNECE Regulation No 100			B
70	Specific components for CNG and their installation on motor vehicles	Regulation (EC) No 661/2009 UNECE Regulation No 110	(a)	Components	X
			(b)	Installation	A

**a** The explanatory notes relating to Part I of Annex IV apply also to Table 1.

## Meaning of letters

X	<p>Full application of the regulatory act.</p> <p>(a) a type-approval certificate shall be issued;</p> <p>(b) tests and checks shall be conducted by the technical service or the manufacturer under the conditions laid down in Articles 41, 42 and 43;</p> <p>(c) a test report shall be drafted in accordance with the provisions of Annex V;</p> <p>(d) Conformity of Production (COP) shall be ensured.</p>
A	<p>Application of the regulatory act as follows:</p> <p>(a) all requirements of the regulatory act shall be fulfilled unless otherwise stated;</p> <p>(b) no type-approval certificate shall be required;</p> <p>(c) tests and checks shall be conducted by the technical service or the manufacturer under the conditions laid down in Articles 41, 42 and 43;</p>

*Note:* The series of amendments of the UNECE Regulations to be used are listed in Annex IV to Regulation (EC) No 661/2009. Series of amendments adopted subsequently are accepted as an alternative.

**Status:** EU Directives are being published on this site to aid cross referencing from UK legislation. After IP completion day (31 December 2020 11pm) no further amendments will be applied to this version.

	(d) a test report shall be drafted in accordance with the provisions of Annex V; (e) COP shall be ensured.
B	Application of the regulatory act as follows: As for letter 'A' with the exception that the tests and checks may be performed by the manufacturer himself subject to the agreement of the type-approval authority (i.e. the conditions laid down in Articles 41, 42 and 43 do not have to be fulfilled).
C	Application of the regulatory act as follows: (a) only the technical requirements from the regulatory shall be fulfilled, irrespective of any transitional provision; (b) no type-approval certificate shall be required; (c) tests and checks shall be conducted by the technical service or by the manufacturer (see decisions for letter 'B'); (d) a test report shall be drafted in accordance with the provisions of Annex V; (e) COP shall be ensured.
D	Same as for decisions in letters 'B' and 'C' with the exception that a statement of compliance submitted by the manufacturer is sufficient. No test report shall be required. The type-approval authority or technical service may require additional information of further evidence, if need be.
N/A	The regulatory act shall not apply. Compliance with one or more specific aspects included in the regulatory act may however be imposed.

*Note:* The series of amendments of the UNECE Regulations to be used are listed in Annex IV to Regulation (EC) No 661/2009. Series of amendments adopted subsequently are accepted as an alternative.

Table 2

<b>N<sub>1</sub> vehicles<sup>a</sup></b>				
<b>Item</b>	<b>Subject</b>	<b>Regulatory act</b>	<b>Specific issues</b>	<b>Applicability and specific requirements</b>
1	Permissible sound level	Directive 70/157/EEC		A
[ <sup>F23</sup> 2	Emissions (Euro 5 and 6) light duty vehicles/access to information	Regulation (EC) No 715/2007	(a) On-board diagnostic (OBD)	The vehicle shall be fitted with an OBD system that fulfils the requirements of Article 4(1) and (2) of Regulation (EC) No 692/2008 (The OBD

**a** The explanatory notes relating to Part I of Annex IV apply also to Table 2. The letters in Table 2 have the same meaning as in Table 1.]

*Status: EU Directives are being published on this site to aid cross referencing from UK legislation. After IP completion day (31 December 2020 11pm) no further amendments will be applied to this version.*

Table 2

**N<sub>1</sub> vehicles<sup>a</sup>**

				system shall be designed to record at least the malfunction of the engine management system). The OBD-interface shall be able to communicate with commonly available diagnostic tools.
			(b)	In service conformity N/A
			(c)	Access to information It is sufficient that the manufacturer provide access to repair and maintenance information in a readily accessible and prompt manner.
			(d)	Power measurement <i>(When the vehicle manufacturer uses an engine from another manufacturer)</i> Bench test data from the engine manufacturer are accepted provided that the engine management system is identical (i.e. having at least the same ECU).

**a** The explanatory notes relating to Part I of Annex IV apply also to Table 2. The letters in Table 2 have the same meaning as in Table 1.]

**Status:** EU Directives are being published on this site to aid cross referencing from UK legislation. After IP completion day (31 December 2020 11pm) no further amendments will be applied to this version.

Table 2

**N<sub>1</sub> vehicles<sup>a</sup>**

				Power output test may be performed on a chassis dynamometer. It shall be taken into account of the power loss in the transmission.]
3A	Prevention of fire risks (liquid fuel tanks)	Regulation (EC) No 661/2009 UNECE Regulation No 34	(a)	Liquid fuel tanks B
			(b)	Installation in vehicle B
[ <sup>F18</sup> 3B	Rear underrun protective devices (RUPDs) and their installation; rear underrun protection (RUP)	Regulation (EC) No 661/2009 UNECE Regulation No 58		B]
4A	Space for mounting and fixing rear registration plates	Regulation (EC) No 661/2009 Regulation (EU) No 1003/2010		B
5A	Steering equipment	Regulation (EC) No 661/2009 UNECE Regulation No 79		C
			(a)	Mechanical systems The provisions of paragraph 5 of UNECE Regulation No 79.01 shall apply. All tests prescribed in paragraph 6.2 of UNECE Regulation No 79 shall be performed and the requirements

**a** The explanatory notes relating to Part I of Annex IV apply also to Table 2. The letters in Table 2 have the same meaning as in Table 1.]

*Status: EU Directives are being published on this site to aid cross referencing from UK legislation. After IP completion day (31 December 2020 11pm) no further amendments will be applied to this version.*

Table 2

**N<sub>1</sub> vehicles<sup>a</sup>**

				of paragraph 6.1 of UNECE Regulation No 79 shall apply.
			(b) Complex electronic vehicle control system	All the requirements of Annex 6 of UNECE Regulation No 79 shall apply. Compliance with these requirements may only be checked by an appointed technical service.
6A	Door latches and door retention components	Regulation (EC) No 661/2009 UNECE Regulation No 11		C
			(a) General requirements (Paragraph 5 of UNECE Regulation No 11)	All requirements shall apply.
			(b) Performance requirements (Paragraph 6 of UNECE Regulation No 11)	Only the requirements of paragraph 6.1.5.4 and paragraph 6.3 on door locks shall apply.
7A	Audible warning devices and signals	Regulation (EC) No 661/2009 UNECE Regulation No 28	(a) Components	X
			(b) Installation on vehicle	B
8A	Devices for indirect vision and their installation	Regulation (EC) No 661/2009 UNECE Regulation No 46	(a) Components	X

<sup>a</sup> The explanatory notes relating to Part I of Annex IV apply also to Table 2. The letters in Table 2 have the same meaning as in Table 1.]



**Status:** EU Directives are being published on this site to aid cross referencing from UK legislation. After IP completion day (31 December 2020 11pm) no further amendments will be applied to this version.

Table 2

**N<sub>1</sub> vehicles<sup>a</sup>**

			(b) Installation on vehicle	B
9A	Braking of vehicles and trailers	Regulation (EC) No 661/2009 UNECE Regulation No 13.	(a) design and test requirements	A
			(b) ESC	The fitting of ESC shall not be required. If fitted, it shall comply with the requirements of UNECE Regulation No 13.
9B	Braking of passenger cars	Regulation (EC) No 661/2009 UNECE Regulation No 13-H	(a) Design and test requirements	A
			(b) Electronic stability control (ESC) and brake assist systems (BAS)	The fitting of BAS and ESC shall not be required. If fitted, they shall comply with the requirements of UNECE Regulation No 13-H.
10A	Electromagnetic compatibility	Regulation (EC) No 661/2009 UNECE Regulation No 10		B
[ <sup>F2</sup> 13A	Protection of motor vehicles against unauthorised use	Regulation (EC) No 661/2009 UNECE Regulation No 116		A The provisions of paragraph 8.3.1.1.1 of UNECE Regulation No 116 may be applied instead of paragraph

<sup>a</sup> The explanatory notes relating to Part I of Annex IV apply also to Table 2. The letters in Table 2 have the same meaning as in Table 1.]

*Status: EU Directives are being published on this site to aid cross referencing from UK legislation. After IP completion day (31 December 2020 11pm) no further amendments will be applied to this version.*

Table 2

**N<sub>1</sub> vehicles<sup>a</sup>**

				8.3.1.1.2 of that Regulation regardless of the type of powertrain]
14A	Protection of the driver against the steering mechanism in the event of impact	Regulation (EC) No 661/2009 UNECE Regulation No 12		C
			(a) Barrier impact test	A test shall be required.
			(b) Body block impact test against steering wheel	Not required if the steering wheel is fitted with an airbag.
			(c) Head form test	Not required if the steering wheel is fitted with an airbag.
15A	Seats, their anchorages and any head restraints	Regulation (EC) No 661/2009 UNECE Regulation N 17		B
17A	Vehicle access and manoeuvrability	Regulation (EC) No 661/2009 Regulation (EU) No 130/2012		D
17B	Speedometer equipment including its installation	Regulation (EC) No 661/2009 UNECE Regulation No 39		B
18A	Manufacturer's statutory plate and vehicle identification number	Regulation (EC) No 661/2009 Regulation (EU) No 19/2011		B
19A	Safety-belt anchorages, Isofix	Regulation (EC) No 661/2009		B

<sup>a</sup> The explanatory notes relating to Part I of Annex IV apply also to Table 2. The letters in Table 2 have the same meaning as in Table 1.]

*Status: EU Directives are being published on this site to aid cross referencing from UK legislation. After IP completion day (31 December 2020 11pm) no further amendments will be applied to this version.*

Table 2

**N<sub>1</sub> vehicles<sup>a</sup>**

	anchorages systems and Isofix top tether anchorages	UNECE Regulation No 14		
20A	Installation of lighting and light-signalling devices on motor vehicles	Regulation (EC) No 661/2009 UNECE Regulation No 48		B DRLs shall be fitted to a new vehicle type in accordance with Article 2 of Directive 2008/89/EC.
21A	Retro-reflecting devices for power-driven vehicles and their trailers	Regulation (EC) No 661/2009 UNECE Regulation No 3		X
22A	Front and rear position lamps, stop-lamps and end-outline marker lamps for motor vehicles and their trailers	Regulation (EC) No 661/2009 UNECE Regulation No 7		X
22B	Daytime running lamps for power-driven vehicles	Regulation (EC) No 661/2009 UNECE Regulation No 87		X
22C	Side-marker lamps for motor vehicles and their trailers	Regulation (EC) No 661/2009 UNECE Regulation No 91		X
23A	Direction indicators for power-driven vehicles and their trailers	Regulation (EC) No 661/2009 UNECE Regulation No 6		X
24A	Illumination of rear-registration plates of power-	Regulation (EC) No 661/2009 UNECE Regulation No 4		X

**a** The explanatory notes relating to Part I of Annex IV apply also to Table 2. The letters in Table 2 have the same meaning as in Table 1.]

*Status: EU Directives are being published on this site to aid cross referencing from UK legislation. After IP completion day (31 December 2020 11pm) no further amendments will be applied to this version.*

Table 2

**N<sub>1</sub> vehicles<sup>a</sup>**

	driven vehicles and their trailers			
25A	Power-driven vehicle's sealed-beam headlamps (SB) emitting an European asymmetrical passing beam or a driving beam or both	Regulation (EC) No 661/2009 UNECE Regulation No 31		X
25B	Filament lamps for use in approved lamp units of power-driven vehicles and their trailers	Regulation (EC) No 661/2009 UNECE Regulation No 37		X
25C	Motor vehicle headlamps equipped with gas-discharge light sources	Regulation (EC) No 661/2009 UNECE Regulation No 98		X
25D	Gas-discharge light sources for use in approved gas-discharge lamp units of power-driven vehicles	Regulation (EC) No 661/2009 UNECE Regulation No 99		X
25E	Motor vehicle headlamps emitting an asymmetrical passing beam or a driving beam or both and equipped with filament lamps and/or LED modules	Regulation (EC) No 661/2009 UNECE Regulation No 112		X
25F	Adaptive front-lighting systems (AFS) for motor vehicles	Regulation (EC) No 661/2009		X

**a** The explanatory notes relating to Part I of Annex IV apply also to Table 2. The letters in Table 2 have the same meaning as in Table 1.]

**Status:** EU Directives are being published on this site to aid cross referencing from UK legislation. After IP completion day (31 December 2020 11pm) no further amendments will be applied to this version.

Table 2

**N<sub>1</sub> vehicles<sup>a</sup>**

		UNECE Regulation No 123		
26A	Power-driven vehicle front fog lamps	Regulation (EC) No 661/2009 UNECE Regulation No 19		X
27A	Towing device	Regulation (EC) No 661/2009 Regulation (EU) No 1005/2010		B
28A	Rear fog lamps for power-driven vehicles and their trailers	Regulation (EC) No 661/2009 UNECE Regulation No 38		X
29A	Reversing lights for power-driven vehicles and their trailers	Regulation (EC) No 661/2009 UNECE Regulation No 23		X
30A	Parking lamps for power-driven vehicles	Regulation (EC) No 661/2009 UNECE Regulation No 77		X
31A	Safety-belts, restraint systems, child restraint systems and Isofix child restraint systems	Regulation (EC) No 661/2009 UNECE Regulation No 16	(a) Components	X
			(b) Installation requirements	B
33A	Location and identification of hand controls, tell-tales and indicators	Regulation (EC) No 661/2009 UNECE Regulation No 121		A
34A	Windscreen defrosting and demisting systems	Regulation (EC) No 661/2009 Regulation (EU) No 672/2010		N/A The vehicle shall be fitted with a suitable windscreen

**a** The explanatory notes relating to Part I of Annex IV apply also to Table 2. The letters in Table 2 have the same meaning as in Table 1.]

*Status: EU Directives are being published on this site to aid cross referencing from UK legislation. After IP completion day (31 December 2020 11pm) no further amendments will be applied to this version.*

Table 2

**N<sub>1</sub> vehicles<sup>a</sup>**

				defrosting and demisting system.
35A	Windscreen wiper and washer systems	Regulation (EC) No 661/2009 Regulation (EU) No 1008/2010		N/A The vehicle shall be fitted with a suitable windscreen wiper and washer system.
36A	Heating system	Regulation (EC) No 661/2009 UNECE Regulation No 122		C The fitting of a heating system shall not be required.
			(a)	All heating systems The requirements of paragraph 5.3 and of paragraph 6 of UNECE Regulation No 122 shall apply.
			(b)	LPG heating systems The requirements of Annex 8 to UNECE Regulation No 122 shall apply.

[<sup>F24</sup>[<sup>F21</sup>

F21

F21

F21]

[ <sup>F23</sup> 41A	Emissions (Euro VI) heavy duty vehicles/ access to information	Regulation (EC) No 595/2009		A With the exception of the set of requirements relating to OBDs and access to information.
----------------------	--	-----------------------------	--	--

<sup>a</sup> The explanatory notes relating to Part I of Annex IV apply also to Table 2. The letters in Table 2 have the same meaning as in Table 1.]

**Status:** EU Directives are being published on this site to aid cross referencing from UK legislation. After IP completion day (31 December 2020 11pm) no further amendments will be applied to this version.

Table 2

**N<sub>1</sub> vehicles<sup>a</sup>**

			Power measurement	<i>(When the vehicle manufacturer uses an engine from another manufacturer) Bench test data from the engine manufacturer are accepted provided that the engine management system is identical (i.e. having at least the same ECU). Power output test may be performed on a chassis dynamometer. It shall be taken into account of the power loss in the transmission.]</i>
43A	Spray suppression systems	Regulation (EC) No 661/2009 Regulation (EU) No 109/2011		B
45A	Safety glazing materials and their installation on vehicles	Regulation (EC) No 661/2009 UNECE Regulation No 43	(a) Components	X
			(b) Installation	B
46	Tyres	Directive 92/23/EEC	Components	X
46A	Installation of tyres	Regulation (EC) No 661/2009 Regulation (EU) No 458/2011		B Dates for progressive application shall be those set out in Article 13 of

**a** The explanatory notes relating to Part I of Annex IV apply also to Table 2. The letters in Table 2 have the same meaning as in Table 1.]

*Status: EU Directives are being published on this site to aid cross referencing from UK legislation. After IP completion day (31 December 2020 11pm) no further amendments will be applied to this version.*

Table 2

**N<sub>1</sub> vehicles<sup>a</sup>**

				Regulation (EC) No 661/2009.
46B	Pneumatic tyres for motor vehicles and their trailers (Class C1)	Regulation (EC) No 661/2009 UNECE Regulation No 30	Components	X
46C	Pneumatic tyres for commercial vehicles and their trailers (Classes C2 and C3)	Regulation (EC) No 661/2009 UNECE Regulation No 54	Components	X
46D	Tyre rolling sound emissions, adhesion on wet surfaces and rolling resistance (Classes C1, C2 and C3)	Regulation (EC) No 661/2009 UNECE Regulation No 117	Components	X
46E	Temporary-use spare unit, run-flat tyres/system and tyre pressure monitoring system	Regulation (EC) No 661/2009 UNECE Regulation No 64	Components	X
			Fitting of a tyre-pressure monitoring system	B The fitting of a TPMS shall not be required
48	Masses and dimensions	Directive 97/27/EC		B
48A	Masses and dimensions	Regulation (EC) No 661/2009 Regulation (EU) No 1230/2012		B
			Hill start test at maximum combination mass	The hill start test at maximum combination mass described in paragraph 5.1 of Part A of Annex 1 to Regulation (EU) No 1230/2012 may be waived at the request of the manufacturer.

<sup>a</sup> The explanatory notes relating to Part I of Annex IV apply also to Table 2. The letters in Table 2 have the same meaning as in Table 1.]



**Status:** EU Directives are being published on this site to aid cross referencing from UK legislation. After IP completion day (31 December 2020 11pm) no further amendments will be applied to this version.

Table 2

**N<sub>1</sub> vehicles<sup>a</sup>**

49A	Commercial vehicles with regards to their external projections forward of the cab's rear panel	Regulation (EC) No 661/2009 UNECE Regulation No 61	(a)	General specifications	C The requirements of paragraph 5 of UNECE Regulation No 61 shall apply
			(b)	Particular specifications	The requirements of paragraph 6 of UNECE Regulation No 61 shall apply.
50A	Mechanical coupling components of combinations of vehicles	Regulation (EC) No 661/2009 UNECE Regulation No 55	(a)	Components	X
			(b)	Installation	B
54A	Protection of occupants in the event of lateral collision	Regulation (EC) No 661/2009 UNECE Regulation No 95	C		C
				Head form test	The manufacturer shall supply the technical service with suitable information concerning a possible impact of the head of the dummy against the structure of the vehicle or the side glazing if made up of laminated glazing. When such impact is proven likely to happen, then the partial test using the head form test described in paragraph 3.1

**a** The explanatory notes relating to Part I of Annex IV apply also to Table 2. The letters in Table 2 have the same meaning as in Table 1.]

*Status: EU Directives are being published on this site to aid cross referencing from UK legislation. After IP completion day (31 December 2020 11pm) no further amendments will be applied to this version.*

Table 2

**N<sub>1</sub> vehicles<sup>a</sup>**

				of Annex 8 to UNECE Regulation No 95 shall be conducted and the criterion specified in paragraph 5.2.1.1 of UNECE Regulation 95 shall be met. In agreement with the technical service, the test procedure described in Annex 4 to UNECE Regulation No 21 may be used as an alternative to the test mentioned above.
56	Vehicles for the carriage of dangerous goods	Regulation (EC) No 661/2009 UNECE Regulation No 105		A
58	Pedestrian protection	Regulation (EC) No 78/2009	(a) Technical requirements applicable to a vehicle	N/A
			(b) Frontal protection systems	X
59	Recyclability	Directive 2005/64/EC		N/A Only Article 7 on reuse of component parts shall apply.

**a** The explanatory notes relating to Part I of Annex IV apply also to Table 2. The letters in Table 2 have the same meaning as in Table 1.]

**Status:** EU Directives are being published on this site to aid cross referencing from UK legislation. After IP completion day (31 December 2020 11pm) no further amendments will be applied to this version.

Table 2

**N<sub>1</sub> vehicles<sup>a</sup>**

61	Air-conditioning systems	Directive 2006/40/EC		B Fluorinated greenhouse gases with a global warming potential higher than 150 are permitted until 31 December 2016.
62	Hydrogen system	Regulation (EC) No 79/2009		X
[ <sup>F2</sup> 63	General Safety	Regulation (EC) No 661/2009		See footnote <sup>0</sup> of the table in Part I of Annex IV with regulatory acts for EC type-approval of vehicles produced in unlimited series]
67	Specific components for liquefied petroleum gases (LPG) and their installation on motor vehicles	Regulation (EC) No 661/2009 UNECE Regulation No 67	(a) Components	X
			(b) Installation	A
68	Vehicle alarm systems (VAS)	Regulation (EC) No 661/2009 UNECE Regulation No 97	(a) Components	X
			(b) Installation	B
69	Electric safety	Regulation (EC) No 661/2009 UNECE Regulation No 100		B
70	Specific components for CNG and their installation on motor vehicles	Regulation (EC) No 661/2009 UNECE Regulation No 110	(a) Components	X
			(b) Installation	A

**a** The explanatory notes relating to Part I of Annex IV apply also to Table 2. The letters in Table 2 have the same meaning as in Table 1.]

*Status: EU Directives are being published on this site to aid cross referencing from UK legislation. After IP completion day (31 December 2020 11pm) no further amendments will be applied to this version.*

Table 2

**N<sub>1</sub> vehicles<sup>a</sup>**

[ <sup>F22</sup> 71]	Cab strength	Regulation (EC) No 661/2009 UNECE Regulation No 29		C]
----------------------	--------------	--	--	----

**a** The explanatory notes relating to Part I of Annex IV apply also to Table 2. The letters in Table 2 have the same meaning as in Table 1.]

<sup>F25</sup>Appendix 2**Requirements for the approval pursuant to Article 24 of complete vehicles belonging to category M<sub>1</sub> and N<sub>1</sub>, produced in large series in or for third countries**

## 0. OBJECTIVE

A vehicle is deemed to be new where:

- (a) it has never been registered previously; or
- (b) it has been registered for less than 6 months at the time of the application for individual approval.

A vehicle shall be considered registered where it has obtained a permanent, temporary or short-term administrative authorisation for entry into service in road traffic, involving its identification and the issuing of a registration number<sup>(68)</sup>.

## 1. ADMINISTRATIVE PROVISIONS

1.1. **Categorisation of the vehicle**

Vehicles shall be categorised according to the criteria set out in Annex II.

For such purposes:

- (a) the actual number of seating positions shall be taken into consideration; and
- (b) the technically maximum permissible laden mass shall be the maximum mass stated by the manufacturer in the country of origin and available in his official documentation.

Where it is not possible to easily determine the vehicle category because of the design of the bodywork, the conditions set out in Annex II shall apply.

1.2 **Application for individual approval**

- (a) The applicant shall submit an application to the approval authority accompanied by all relevant documentation necessary for the operation of the approval process.

Where the submitted documentation is incomplete, falsified or forged the application for approval shall be rejected.

- (b) Only one application for a particular vehicle may be submitted in only one Member State.

By a particular vehicle, it shall be understood a physical vehicle the vehicle identification number of which is clearly identified.

For the application of this point, the approval authority may require that the applicant commits himself in writing that he will submit only one application in one Member State.

However, any applicant may apply for individual approval in another Member States in respect of a vehicle that has technical characteristics identical or similar to the one that has been granted an individual approval.

- (c) The model of the application form and the layout of the file shall be laid down by the approval authority.

Particulars may only consist in an appropriate selection of the information included in Annex I.

- (d) The technical requirements to be satisfied are those laid down in Section 4 of this Appendix.

They shall be those applicable to new vehicles belonging to a vehicle type currently in production, in relation to the date of the submission of the application.

- (e) With respect to certain tests required in some regulatory acts listed in this Annex, the applicant shall supply a statement of compliance with recognised international standards or regulations. The statement in question may only be issued by the vehicle manufacturer.

‘Statement of compliance’ shall mean a statement issued by the office or department within the manufacturer’s organisation which is duly authorised by the management to fully engage the legal responsibility of the manufacturer with respect to the design and the construction of a vehicle.

The regulatory acts for which such a statement has to be supplied shall be those referred to in Section 4 of this Appendix.

Where a statement gives rise to uncertainty, the applicant may be required to obtain from the manufacturer a conclusive piece of evidence, including a test report, in order to corroborate the manufacturer’s statement.

### 1.3. **Technical services entrusted with individual approvals**

- (a) The technical services entrusted with individual approvals shall be of category A as referred to in Article 41(3).

- (b) By way of derogation from the second subparagraph of Article 41(4), technical services shall comply with the following standards:

- (i) EN ISO/IEC 17025:2005 when they perform tests themselves;
- (ii) EN ISO/IEC 17020:2004 when they check compliance of the vehicle with the requirements included in this Appendix.

- (c) Where specific tests requiring specific skills have to be conducted at the request of the applicant, they shall be conducted by one of the technical services notified to the Commission at the choice of the applicant.

For example, where a frontal impact test has to be conducted in agreement with the applicant in a Member State ‘A’, the test may be conducted by a notified technical service in a Member State ‘B’.

---

*Status: EU Directives are being published on this site to aid cross referencing from UK legislation. After IP completion day (31 December 2020 11pm) no further amendments will be applied to this version.*

---

#### 1.4. **Test reports**

(a) Test reports shall be drafted in accordance with Section 5.10.2 of Standard EN ISO/IEC 17025:2005.

(b) They shall be drafted in one of the languages of the Union determined by the approval authority.

Where in application of point 1.3(c) a test report has been established in a Member State other than the one entrusted with the individual approval, the approval authority may require that the applicant submits a true translation of the test report.

(c) They shall include a description of the vehicle tested including unambiguous identification. The parts which play a significant role with regard to the results of the tests shall be described and their identification number reported.

Examples of parts include the silencers for noise measurement and the engine management system (ECU) for the measurement of tailpipe emissions.

(d) At the request of an applicant, a test report delivered for a system related to a particular vehicle may be presented repeatedly either by the same or another applicant for the purposes of individual approval of another vehicle.

In such a case the approval authority shall ensure that the technical characteristics of the vehicle are properly inspected against the test report.

Inspection of the vehicle and the documentation accompanying the test report shall lead to the conclusion that the vehicle for which an individual approval is sought has the same characteristics as the vehicle described in the report.

(e) Only authenticated copies of a test report may be submitted.

(f) Test reports referred to in point 1.4(d) do not include the reports drawn up in order to grant the vehicle individual approval.

1.5. It is inherent in the individual approval process that each particular vehicle is inspected physically by the technical service.

No exemption to this principle shall be permitted.

1.6. Where the approval authority is satisfied that the vehicle meets the technical requirements specified in this Appendix and conforms to the description included in the application it shall grant approval in accordance with Article 24.

1.7. The certificate of approval shall be drafted according to Model D as laid down in Annex VI.

1.8. The approval authority shall keep record of all approvals granted under Article 24.

## 2. EXEMPTIONS

2.1. Due to the specific nature of the individual procedure, the following Articles of this Directive including the respective provisions in the relevant annexes shall be waived:

(a) Article 12 relating to conformity of production arrangements;

(b) Articles 8, 9, 13, 14 and 18 relating to vehicle type-approval procedure.

## 2.2. **Vehicle type identification**

**Status:** EU Directives are being published on this site to aid cross referencing from UK legislation. After IP completion day (31 December 2020 11pm) no further amendments will be applied to this version.

- (a) As far as possible, the type, the variant and the version which is given in its country of origin shall be referred to in the approval certificate.
- (b) Where it is not possible to identify the type, the variant and the version because of the absence of appropriate data, the usual commercial name of the vehicle may be referred to.

### 3. REVIEW OF THE TECHNICAL REQUIREMENTS

The list of the technical requirements included in Section 4 will be regularly reviewed in order to take account of the results of the harmonisation work in progress at the World Forum for Harmonization of Vehicle Regulations (WP.29) in Geneva and legislative developments in the third countries.

### 4. TECHNICAL REQUIREMENTS

#### Part I: Vehicles belonging to category M<sub>1</sub>

Item	Regulatory act reference	Alternative requirements
1	Directive 70/157/EEC (Permissible sound level)	<p><i>Drive-by test</i></p> <p>(a) A test shall be conducted in accordance with the 'Method A' referred to in Annex 3 to UNECE Regulation No 51.</p> <p>Limits are those specified in Section 2.1 of Annex I to Directive 70/157/EEC. 1 decibel in addition to the permitted limits shall be allowed.</p> <p>(b) The test track shall comply with Annex 8 to UNECE Regulation No 51. A test track having different specifications may be used under the condition that correlation tests have been conducted by the technical service. A correction factor shall be applied if necessary.</p> <p>(c) Exhaust systems containing fibrous</p>

*Status: EU Directives are being published on this site to aid cross referencing from UK legislation. After IP completion day (31 December 2020 11pm) no further amendments will be applied to this version.*

### Part I: Vehicles belonging to category M<sub>1</sub>

		<p>materials need not be conditioned as prescribed in Annex 5 to UNECE Regulation No 51.</p> <p><i>Stationary test</i> A test shall be conducted in accordance with Section 3.2 of Annex 3 to UNECE Regulation No 51.</p>
2	Directive 70/220/EEC (Emissions)	<p><i>Tailpipe emissions</i></p> <p>(a) A type I test shall be conducted in accordance with Annex III to Directive 70/220/EEC using the deterioration factors referred to in point 5.3.6.2. The limits to be applied shall be those specified in point 5.3.1.4 of Annex I to that Directive.</p> <p>(b) The vehicle shall not be required to exhibit 3 000 km as requested in Section 3.1.1 of Annex III to that Directive.</p> <p>(c) The fuel to be used for the test shall be the reference fuel as prescribed in Annex IX to Directive 70/220/EEC.</p> <p>(d) The dynamometer shall be set up in accordance with the technical requirements of Section 3.2 of Appendix 2 to Annex III to that Directive.</p>



*Status: EU Directives are being published on this site to aid cross referencing from UK legislation. After IP completion day (31 December 2020 11pm) no further amendments will be applied to this version.*

### Part I: Vehicles belonging to category M<sub>1</sub>

		<p>(e) The test referred to in point (a) shall not be conducted where it can be demonstrated that the vehicle complies with one of the California Regulations mentioned in the prefatory note to Section 5 of Annex I to that Directive.</p> <p><i>Evaporative emissions</i> Vehicles equipped with a petrol-fuelled engine shall be fitted with an evaporate emissions control system (e.g. charcoal canister).</p> <p><i>Crankcase emissions</i> The presence of a device for recycling crankcase gases shall be required.</p> <p><i>OBD</i> The vehicle shall be fitted with an OBD system. OBD-interface shall be able to communicate with common diagnostic tools used for periodic technical inspections.</p>
I <sup>F23</sup> 2a	Regulation (EC) No 715/2007 (Emissions Euro 5 and 6 light duty vehicles/access to information)	<p><i>Tailpipe emissions</i></p> <p>(a) A type I test shall be conducted in accordance with Annex III to Regulation (EC) No 692/2008 using the deterioration factors set out in point 1.4 of Annex VII to Regulation (EC) No 692/2008. The limits to be applied shall be those specified in Table I and Table II in Annex I to</p>

*Status: EU Directives are being published on this site to aid cross referencing from UK legislation. After IP completion day (31 December 2020 11pm) no further amendments will be applied to this version.*

### Part I: Vehicles belonging to category M<sub>1</sub>

		<p>Regulation (EC) No 715/2007.</p> <p>(b) The vehicle shall not be required to exhibit 3 000 km as mentioned in Section 3.1.1 of Annex 4 to UNECE Regulation No 83.</p> <p>(c) The fuel to be used for the test shall be the reference fuel as prescribed in Annex IX to Regulation (EC) No 692/2008.</p> <p>(d) The dynamometer shall be set up in accordance with the technical requirements set out in Section 3.2 of Annex 4 to UNECE Regulation No 83.</p> <p>(e) The test referred to in point (a) shall not be conducted where it can be shown that the vehicle complies with the California Regulations referred to in Section 2 of Annex I to Regulation (EC) No 692/2008.</p> <p><i>Evaporative emissions</i> For petrol-fuelled engines, the presence of an evaporate emissions control system shall be required (e.g. a charcoal canister).</p> <p><i>Crankcase emissions</i> The presence of a device for recycling crankcase gases shall be required.</p> <p><i>OBD</i></p>
--	--	--

---

**Part I: Vehicles belonging to category M<sub>1</sub>**

---

		<p>(a) The vehicle shall be fitted with an OBD system.</p> <p>(b) OBD-interface must be able to communicate with common diagnostic tools used for periodic technical inspections.</p> <p><i>Smoke opacity</i></p> <p>(a) Vehicles equipped with a diesel-fuelled engine shall be tested in accordance with the tests methods referred to in Appendix 2 to Annex IV to Regulation (EC) No 692/2008.</p> <p>(b) The corrected value of the absorption coefficient shall be affixed conspicuously and in a readily accessible place.</p> <p><i>CO<sub>2</sub> emissions and fuel consumption</i></p> <p>(a) A test shall be conducted in accordance with Annex XII to Regulation (EC) No 692/2008.</p> <p>(b) The vehicle shall not be required to exhibit 3 000 km as requested in Section 3.1.1 of Annex 4 to UNECE Regulation No 83.</p> <p>(c) Where the vehicle complies with the California</p>
--	--	--

*Status: EU Directives are being published on this site to aid cross referencing from UK legislation. After IP completion day (31 December 2020 11pm) no further amendments will be applied to this version.*

### Part I: Vehicles belonging to category M<sub>1</sub>

		<p>Regulations referred to in Section 2 of Annex I to Regulation (EC) No 692/2008 and therefore no test of tailpipe emissions is required to be performed, Member States shall calculate CO<sub>2</sub> emissions and fuel consumption with the formulæ laid down in the explanatory notes <sup>(b)</sup> and <sup>(c)</sup>.</p> <p><i>Access to information</i> The provisions regarding access to information shall not apply.</p> <p><i>Power measurement</i></p> <p>(a) The applicant shall submit a statement from the manufacturer stating the maximum engine power output in kW as well as the corresponding engine speed in revolutions per minute.</p> <p>(b) An engine power output curve providing the same information may alternatively be referred to.]</p>
3	Directive 70/221/EEC (Fuel tanks — Rear protective devices)	<p><i>Fuel tanks</i></p> <p>(a) Fuel tanks shall comply with Section 5 of Annex I to Directive 70/221/EEC with the exception of points 5.1, 5.2 and</p>

---

**Part I: Vehicles belonging to category M<sub>1</sub>**

---

		<p>5.12. In particular they shall comply with points 5.9 and 5.9.1 but no dripping test shall be conducted.</p> <p>(b) LPG or CNG tanks shall be type-approved in accordance with, respectively UNECE Regulations 67 series of amendments 01 or Regulation No 110<sup>(a)</sup>.</p> <p><i>Specific provisions for fuel tanks made of a plastic material</i></p> <p>The applicant shall submit a statement from the manufacturer establishing that the fuel tank on the particular vehicle, [<i>the VIN number of which has to be specified</i>], complies either with at least one of the following:</p> <ul style="list-style-type: none"> <li>— Section 6.3 of Directive 70/221/EEC,</li> <li>— FMVSS No 301 (Fuel system integrity),</li> <li>— Annex 5 to UNECE Regulation 34.</li> </ul> <p><i>Rear protective device</i></p> <p>(a) The rear part of the vehicle shall be constructed in accordance with Section 5 of Annex II to Directive 70/221/EEC.</p> <p>(b) For such purposes, it is sufficient that the requirements set out in the second</p>
--	--	---

*Status: EU Directives are being published on this site to aid cross referencing from UK legislation. After IP completion day (31 December 2020 11pm) no further amendments will be applied to this version.*

### Part I: Vehicles belonging to category M<sub>1</sub>

		subparagraph of point 5.2 are fulfilled.
4	Directive 70/222/EEC (Rear registration plate space)	Space, inclination, angles for visibility and position of the registration plate shall comply with Directive 70/222/EEC.
5	Directive 70/311/EEC (Steering effort)	<p><i>Mechanical systems</i></p> <p>(a) The steering mechanism shall be built as to self-centre. In order to check compliance with this provision, a test shall be conducted in accordance with points 5.1.2 and 5.2.1 of Annex I to Directive 70/311/EEC.</p> <p>(b) The failure of the power steering equipment shall not lead to a complete loss of control of the vehicle.</p> <p><i>Complex electronic vehicle control system ('Drive-by wire' devices)</i> Complex electronic control system shall be permitted only if they comply with Annex 6 to UNECE Regulation No 79.</p>
6	Directive 70/387/EEC (Door latches and hinges)	<p>(a) Door latches and hinges shall comply with points 3.2.1, 3.3.2 and 3.4.1 of Annex I to Directive 70/387/EEC.</p> <p>(b) The requirements set out in point 3.4.1 shall not apply where compliance</p>

<b>Part I: Vehicles belonging to category M<sub>1</sub></b>		
		with point 6.1.5.4 of UNECE Regulation No 11 Rev.1 Amendment 2 is demonstrated.
7	Directive 70/388/EEC (Audible warning)	<p><i>Components</i></p> <p>The audible warning devices are not required to be type-approved in accordance with Directive 70/388/EEC. However, they shall emit a continuous sound as required in point 1.1 of Annex I to that Directive.</p> <p><i>Installation on vehicle</i></p> <p>(a) A test shall be conducted in accordance with Section 2 of Annex I to Directive 70/388/EEC.</p> <p>(b) The maximum sound pressure level shall be in accordance with point 2.1.4 of that Annex.</p>
8	Directive 2003/97/EC (Indirect vision devices)	<p><i>Components</i></p> <p>(a) The vehicle shall be fitted with the rear-view mirrors prescribed in Section 2 of Annex III to Directive 2003/97/EC.</p> <p>(b) They are not required to be type-approved in accordance with that Directive.</p> <p>(c) The radii of curvature of the mirrors shall not cause significant image distortions. At the discretion of the technical</p>

*Status: EU Directives are being published on this site to aid cross referencing from UK legislation. After IP completion day (31 December 2020 11pm) no further amendments will be applied to this version.*

### Part I: Vehicles belonging to category M<sub>1</sub>

		<p>service, the radii of curvature shall be checked in accordance with the method described in Appendix 1 to Annex II to that Directive. The radii of curvature shall not be less than those required by Section 3.4 of Annex II to that Directive.</p> <p><i>Installation on vehicle</i> Measurement shall be conducted in order to ensure that the fields of vision comply either with Section 5 of Annex III to Directive 2003/97/EC or with Section 5 of Annex III to Directive 71/127/EEC.</p>
9	Directive 71/320/EEC (Braking)	<p><i>General provisions</i></p> <p>(a) The braking system shall be built in accordance with Section 2 of Annex I to Directive 71/320/EEC.</p> <p>(b) Vehicles shall be fitted with an electronic antilock braking system acting on all wheels.</p> <p>(c) The performances of the braking system shall comply with Section 2 of Annex II to that Directive.</p> <p>(d) For these purposes, road tests shall be conducted on a track the surface of which possesses high adhesion. The</p>



---

**Part I: Vehicles belonging to category M<sub>1</sub>**

---

		<p>test on the parking brake shall be conducted on a 18 % gradient (up and down).</p> <p>Only those tests mentioned below shall be conducted. In each case, the vehicle shall be in fully laden conditions.</p> <p>(e) The road test referred to in point (c) above shall not be conducted where the applicant can submit a statement from the manufacturer establishing that the vehicle complies either with UNECE Regulation No 13-H including supplement 5 or with FMVSS No 135.</p> <p><i>Service brake</i></p> <p>(a) A ‘Type 0’ test as prescribed in points 1.2.2 and 1.2.3 of Annex II to Directive 71/320/EEC shall be conducted.</p> <p>(b) In addition, a ‘Type I’ test as prescribed in point 1.3 of Annex II to that Directive shall be conducted.</p> <p><i>Parking brake</i></p> <p>A test shall be conducted in accordance with point 2.1.3 of Annex II to that Directive.</p>
10	Directive 72/245/EEC (Radio interference (electromagnetic compatibility))	<p><i>Components</i></p> <p>(a) Electrical/electronic sub-assemblies are not required to be type-approved in</p>

*Status: EU Directives are being published on this site to aid cross referencing from UK legislation. After IP completion day (31 December 2020 11pm) no further amendments will be applied to this version.*

### Part I: Vehicles belonging to category M<sub>1</sub>

		<p>accordance with Directive 72/245/EEC.</p> <p>(b) However, electric/electronic devices retrofitted shall comply with that Directive.</p> <p><i>Emitted electromagnetic radiations</i> The applicant shall submit a statement from the manufacturer establishing that the vehicle complies with Directive 72/245/EEC or with the following alternative standards:</p> <ul style="list-style-type: none"> <li>— Broadband electromagnetic radiation: CISPR 12 or SAE J551-2,</li> <li>— Narrowband electromagnetic radiation: CISPR 12 (off-board) or 25 (in-board) or SAE J551-4 and SAE J1113-41.</li> </ul> <p><i>Immunity tests</i> Immunity test shall be waived.</p>
11	Directive 72/306/EEC (Diesel smoke)	<p>(a) A test shall be conducted in accordance with the methods described in Annex III and IV to Directive 72/306/EEC.</p> <p>The limit values applicable are those mentioned in Annex V to that Directive.</p> <p>(b) The corrected value of the absorption coefficient referred to in Section 4 of Annex I to Directive 72/306/EEC shall be affixed</p>

<b>Part I: Vehicles belonging to category M<sub>1</sub></b>		
		conspicuously and in a readily accessible place.
12	Directive 74/60/EEC (Interior fittings)	<p><i>Interior arrangement</i></p> <p>(a) With respect to the requirements on energy absorption, the vehicle shall be deemed to comply with Directive 74/60/EEC if the vehicle is fitted with at least two front airbags, one inserted into the steering wheel and the other into the dashboard.</p> <p>(b) Where the vehicle is fitted with only one front air bag inserted in the steering wheel, the dashboard shall be made up of energy absorbing materials.</p> <p>(c) The technical service shall check that there are no sharp edges in the zones defined in Sections 5.1 to 5.7 of Annex I to Directive 74/60/EEC.</p> <p><i>Electrical controls</i></p> <p>(a) Power-operated windows, roof-panel systems and partitioning systems shall be tested in accordance with Section 5.8 of Annex I to that Directive.</p> <p>The sensitivity of auto-reverse systems referred to in point 5.8.3 of that</p>

*Status: EU Directives are being published on this site to aid cross referencing from UK legislation. After IP completion day (31 December 2020 11pm) no further amendments will be applied to this version.*

### Part I: Vehicles belonging to category M<sub>1</sub>

		Annex may diverge from the requirements set out in point 5.8.3.1.1.  (b) Electric windows which cannot be closed when the ignition is off shall be exempt from the requirements concerning auto-reverse systems.
13	Directive 74/61/EEC (Anti-theft and immobiliser)	(a) In order to prevent unauthorised use, the vehicle shall be fitted with: — a locking device as defined in Section 2.2 of Annex IV to Directive 74/61/EEC, and — an immobiliser which meets the technical requirements of Section 3 of Annex V to that Directive and the essential requirements of Section 4, in particular point 4.1.1.  (b) If, in application of point (a) above, an immobiliser has to be retrofitted it shall be of an approved type in accordance with Directive 74/61/EEC or UNECE Regulation No 97 or No 116.
14	Directive 74/297/EEC <sup>(d)</sup> (Protective steering)	(a) The applicant shall submit a statement from the manufacturer establishing that the

---

**Part I: Vehicles belonging to category M<sub>1</sub>**

---

		<p>particular vehicle, [the VIN number of which has to be specified], complies with at least one of the following:</p> <ul style="list-style-type: none"> <li>— Directive 74/297/EEC,</li> <li>— FMVSS No 203 (Impact protection for the driver from the steering control system) including FMVSS No 204 (Steering control rearward displacement),</li> <li>— Article 11 of JSRRV.</li> </ul> <p>(b) A test in accordance with Annex II to Directive 74/297/EEC may be conducted on a production vehicle at the request of the applicant.</p> <p>The test shall be conducted by a notified European technical service which has competence therein. A detailed report shall be issued to the applicant.</p>
15	Directive 74/408/EEC (Seat strength — head restraints)	<p><i>Seats, seat anchorages and adjustment systems</i></p> <p>The applicant shall submit a statement from the manufacturer establishing that the particular vehicle, [the VIN number of which has to be specified], complies with at least one of the following:</p> <ul style="list-style-type: none"> <li>— Directive 74/408/EEC,</li> <li>— FMVSS No 207 (Seating systems).</li> </ul> <p><i>Head restraints</i></p>

*Status: EU Directives are being published on this site to aid cross referencing from UK legislation. After IP completion day (31 December 2020 11pm) no further amendments will be applied to this version.*

### Part I: Vehicles belonging to category M<sub>1</sub>

		<p>(a) Where the statement referred to above is based on FMVSS No 207, the head restraints shall fulfil in addition the essential requirements of Section 3 of Annex II to Directive 74/408/EEC and those of Section 5 of Appendix I to the same Annex.</p> <p>(b) Only the tests described in point 3.10 and Sections 5, 6 and 7 of Annex II to that Directive shall be conducted.</p> <p>(c) In the other event, the applicant shall submit a statement from the manufacturer establishing that the particular vehicle, [<i>the VIN number of which has to be specified</i>], complies with FMVSS No 202a (Head restraints).</p>
16	Directive 74/483/EEC (Exterior projections)	<p>(a) The external surface of the bodywork shall comply with the general requirements included in Section 5 of Annex I to Directive 74/483/EEC.</p> <p>(b) At the discretion of the technical service the provisions referred to in points</p>

<b>Part I: Vehicles belonging to category M<sub>1</sub></b>		
		6.1, 6.5, 6.6, 6.7, 6.8 and 6.11 of Annex I to that Directive shall be checked.
17	Directive 75/443/EEC (Speedometer — reverse gear)	<p><i>Speedometer equipment</i></p> <p>(a) The dial shall comply with points 4.1 to 4.2.3 of Annex II to Directive 75/443/EEC.</p> <p>(b) Where the technical service has reasonable grounds to believe that the speedometer is not calibrated with sufficient accuracy, it may require that the tests prescribed in Section 4.3 be conducted.</p> <p><i>Reverse gear</i> The gear mechanism shall include a reverse gear.</p>
18	Directive 76/114/EEC (Statutory plates)	<p><i>Vehicle identification number</i></p> <p>(a) The vehicle shall be fitted with a vehicle identification number comprising a minimum of 8 and a maximum of 17 characters. Vehicle identification number comprising 17 characters shall fulfil the requirements set out in Standards ISO 3779:1983 and 3780:1983.</p> <p>(b) The vehicle identification number shall be located in a clearly visible</p>

*Status: EU Directives are being published on this site to aid cross referencing from UK legislation. After IP completion day (31 December 2020 11pm) no further amendments will be applied to this version.*

### Part I: Vehicles belonging to category M<sub>1</sub>

		<p>and accessible position in such a way as it cannot be obliterated or deteriorate.</p> <p>(c) Where no vehicle identification number is stamped in the chassis or in the body, a Member State may require that it is retrofitted in application of its national law. In such a case, the competent authority of that Member State shall supervise the operation.</p> <p><i>Statutory plate</i> The vehicle shall be fitted with an identification plate affixed by the vehicle manufacturer. No additional plate shall be requested after the approval has been granted.</p>
19	Directive 76/115/EEC (Seat belt anchorages)	<p>The applicant shall submit a statement from the manufacturer establishing that the particular vehicle, [the VIN number of which has to be specified], complies with at least one of the following:</p> <ul style="list-style-type: none"> <li>— Directive 76/115/EEC,</li> <li>— FMVSS No 210 (Seat belt assembly anchorages),</li> <li>— Article 22-3 of JSRRV.</li> </ul>
20	Directive 76/756/EEC (Installation of lighting and light signalling devices)	<p>(a) The lighting installation shall meet the essential requirements of UNECE Regulation No 48 series of amendments</p>



---

**Part I: Vehicles belonging to category M<sub>1</sub>**

---

		<p>03 with the exception of those of Annexes 5 and 6 to Regulation 48.</p> <p>(b) No exemption shall be permitted in respect of the number, the essential design characteristics, the electrical connections, and the colour of light emitted or retro-reflected of the lights and signalling devices referred to in Entries 21 to 26 and in Entries 28 to 30.</p> <p>(c) Lights and signalling devices which in application of the above must be retrofitted shall bear an 'EC' type-approval mark.</p> <p>(d) Lamps fitted with gas-discharged light source are only permitted in conjunction with the installation of headlamp cleaning device and an automatic headlamp-levelling device where appropriate.</p> <p>(e) Headlamp dipped-beams shall be adapted to the direction of traffic legally in force in the country where the vehicle is granted approval.</p>
--	--	--

---

*Status: EU Directives are being published on this site to aid cross referencing from UK legislation. After IP completion day (31 December 2020 11pm) no further amendments will be applied to this version.*

<b>Part I: Vehicles belonging to category M<sub>1</sub></b>		
21	Directive 76/757/EEC (Retro reflectors)	Where necessary, two additional retro reflectors bearing an 'EC' approval mark shall be added at the rear, the position of which shall comply with UNECE Regulation No 48.
22	Directive 76/758/EEC (End-outline, front position (side), rear-position (side), stop, side marker, daytime running lamps)	The requirements set out in that Directive shall not apply. However, the correct functioning of the lights shall be checked by the technical service.
23	Directive 76/759/EEC (Direction indicators)	The requirements set out in that Directive shall not apply. However, the correct functioning of the lights shall be checked by the technical service.
24	Directive 76/760/EEC (Rear registration plate lamps)	The requirements set out in that Directive shall not apply. However, the correct functioning of the lights shall be checked by the technical service.
25	Directive 76/761/EEC (Headlamps (including bulbs))	<p>(a) The illumination produced by the passing beam of the headlamps fitted to the vehicle shall be checked under Section 6 of UNECE Regulation No 112 concerning headlamps emitting an asymmetrical passing beam. The tolerances included in Annex 5 to that Regulation may be referred to for that purpose.</p> <p>(b) The same decision shall apply <i>mutatis mutandis</i> to the passing beam of headlamps</p>

<b>Part I: Vehicles belonging to category M<sub>1</sub></b>		
		covered by UNECE Regulation No 98 or No 123.
26	Directive 76/762/EEC (Front fog lamps)	The requirements set out in that Directive shall not apply. However, the correct functioning of the lights if fitted shall be checked by the technical service.
27	Directive 77/389/EEC (Towing hooks)	The requirements set out in that Directive shall not apply.
28	Directive 77/538/EEC (Rear fog lamps)	The requirements set out in that Directive shall not apply. However, the correct functioning of the lights shall be checked by the technical service.
29	Directive 77/539/EEC (Reversing lamps)	The requirements set out in that Directive shall not apply. However, the correct functioning of the lights if fitted shall be checked by the technical service.
30	Directive 77/540/EEC (Parking lamps)	The requirements set out in that Directive shall not apply. However, the correct functioning of the lights if fitted shall be checked by the technical service.
31	Directive 77/541/EEC (Seat belts and restraint systems)	<p><i>Components</i></p> <p>(a) Seat belts shall not be required to be type-approved in accordance with Directive 77/541/EEC.</p> <p>(b) However, each seat belt shall bear an identification label.</p> <p>(c) The indications on the label shall be consistent with the decision concerning seat belt anchorages (Re: entry 19).</p> <p><i>Installation requirements</i></p>

*Status: EU Directives are being published on this site to aid cross referencing from UK legislation. After IP completion day (31 December 2020 11pm) no further amendments will be applied to this version.*

### Part I: Vehicles belonging to category M<sub>1</sub>

		<p>(a) The vehicle shall be fitted with seat belts in accordance with the requirements set out in Annex XV to Directive 77/541/EEC.</p> <p>(b) Where a number of seat belts have to be retrofitted in accordance with point (a) above, they shall be of an approved type in accordance with Directive 77/541/EEC or UNECE Regulation No 16.</p>
32	Directive 77/649/EEC (Forward vision)	<p>(a) No obstruction in the 180° forward field of vision of the driver as defined in point 5.1.3 of Annex I to Directive 77/649/EEC shall be permitted.</p> <p>(b) By derogation from point (a) above, the 'A pillars' and the equipment listed in point 5.1.3 of Annex I to that Directive shall not be considered as obstruction.</p> <p>(c) The number of 'A pillars' shall not exceed 2.</p>
33	Directive 78/316/EEC (Identification of controls, tell-tales and indicators)	<p>(a) The symbols including the colour of their corresponding tell-tales the presence of which is mandatory by virtue of Annex</p>

<b>Part I: Vehicles belonging to category M<sub>1</sub></b>		
		<p>II to Directive 78/316/EEC shall comply with that Directive.</p> <p>(b) Where this is not the case, the technical service shall verify that the symbols, tell-tales and indicators fitted to the vehicle provide the driver with comprehensible information about the operation of the controls in question.</p>
34	Directive 78/317/EEC (Defrost/Demist)	<p>The vehicle shall be equipped with adequate windscreen defrosting and windscreen demisting devices.</p> <p>Shall be deemed 'adequate' any windscreen defrosting device which complies as a minimum with point 5.1.1 of Annex I to Directive 78/317/EEC.</p> <p>Shall be deemed 'adequate' any windscreen demisting device which complies as a minimum with point 5.2.1 of Annex I to that Directive.</p>
35	Directive 78/318/EEC (Wash/Wipe)	<p>The vehicle shall be equipped with adequate windscreen washing and windscreen wiping devices.</p> <p>Shall be deemed 'adequate' any windscreen washing and wiping device which complies as a minimum with the conditions set out in point 5.1.3 of Annex I to Directive 78/318/EEC.</p>
36	Directive 2001/56/EC (Heating systems)	<p>(a) The passenger compartment shall be fitted with a heating system.</p>

*Status: EU Directives are being published on this site to aid cross referencing from UK legislation. After IP completion day (31 December 2020 11pm) no further amendments will be applied to this version.*

### Part I: Vehicles belonging to category M<sub>1</sub>

		<p>(b) Combustion heaters and their installation shall comply with Annex VII to Directive 2001/56/EC. In addition, LPG combustion heaters and LPG heating systems shall fulfil the requirements set out in Annex VIII to that Directive.</p> <p>(c) Additional heating systems which are retrofitted shall comply with the requirements set out in that Directive.</p>
37	Directive 78/549/EEC (Wheel guards)	<p>(a) The vehicle shall be designed as to protect other road users against thrown-up stones, mud, ice, snow and water and to reduce the dangers due to contact with the moving wheels.</p> <p>(b) The technical service may check that the essential technical requirements set out in Annex I to Directive 78/549/EEC are complied with.</p> <p>(c) The provisions of Section 3 of Annex I to that Directive shall not apply.</p>
38	Directive 78/932/EEC (Head restraints)	The requirements of Directive 78/932/EEC shall not apply.

---

**Part I: Vehicles belonging to category M<sub>1</sub>**

---

39	Directive 80/1268/EEC (CO <sub>2</sub> emissions/fuel consumption)	<p>(a) A test shall be conducted in accordance with Section 5 of Annex I to Directive 80/1268/EEC.</p> <p>(b) The requirements set out in point 5.1.1 of that Annex shall not apply.</p> <p>(c) Where no test concerning tailpipe emissions is conducted in application of the provisions referred to in Entry 2, CO<sub>2</sub> emissions and fuel consumption shall be calculated with the formula laid down in the explanatory notes <sup>(b)</sup> and <sup>(c)</sup>.</p>
[ <sup>F26</sup> ]		
41	Directive 2005/55/EC (Emissions (Euro 4 and 5) heavy duty vehicles — OBDs — Smoke opacity)	<p><i>Tailpipe emissions</i></p> <p>(a) A test shall be conducted in accordance with Section 6.2 of Annex I to Directive 2005/55/EC using the deterioration factors set out in point 3.6 of Annex II to Directive 2005/78/EC.</p> <p>(b) The limits shall be those set out in Table I or Table 2 in Annex I to Directive 2005/55/EC.</p> <p><i>OBD</i></p>

*Status: EU Directives are being published on this site to aid cross referencing from UK legislation. After IP completion day (31 December 2020 11pm) no further amendments will be applied to this version.*

### Part I: Vehicles belonging to category M<sub>1</sub>

		<p>(a) The vehicle shall be fitted with an OBD system.</p> <p>(b) OBD-interface must be able to communicate with common diagnostic tools used for periodic technical inspections.</p> <p><i>Smoke opacity</i></p> <p>(a) Vehicles equipped with a diesel-fuelled engine shall be tested in accordance with the tests methods referred to in Annex VI to Directive 2005/55/EC.</p> <p>(b) The corrected value of the absorption coefficient shall be affixed conspicuously and in a readily accessible place.</p>
I <sup>F10</sup> 41a	Regulation (EC) No 595/2009 Emissions (Euro VI) heavy-duty vehicles – OBD	<p><i>Tailpipe emissions</i></p> <p>(a) A test shall be conducted in accordance with Annex III to Regulation (EU) No 582/2011 using the deterioration factors set out in point 3.6.1. of Annex VI to Regulation (EU) No 582/2011.</p> <p>(b) The limits to be applied shall be those set out in the table of Annex I to Regulation (EC) No 595/2009.</p>



---

**Part I: Vehicles belonging to category M<sub>1</sub>**

---

		<p>(c) The fuel to be used for the test shall be the reference fuel as prescribed in Annex IX to Regulation (EU) No 582/2011.</p> <p><i>CO<sub>2</sub> emissions</i> The CO<sub>2</sub> emissions and fuel consumption shall be determined in accordance with Annex VIII to Regulation (EU) No 582/2011.</p> <p><i>OBD</i></p> <p>(a) The vehicle shall be fitted with an OBD system.</p> <p>(b) The OBD-interface must be able to communicate with an external OBD scan-tool as described in Annex X to Regulation (EU) No 582/2011.</p> <p><i>Requirements to ensure the correct operation of NO<sub>x</sub> control measures</i> The vehicle shall be fitted with a system ensuring the correct operation of NO<sub>x</sub> control measures in accordance with Annex XIII to Regulation (EU) No 582/2011. The provisions on alternative type-approval set out in point 2.1. of that Annex shall also apply.</p> <p><i>Power measurement</i></p> <p>(a) The applicant shall submit a statement from the manufacturer stating the maximum engine power output in kW as well as the corresponding</p>
--	--	--

*Status: EU Directives are being published on this site to aid cross referencing from UK legislation. After IP completion day (31 December 2020 11pm) no further amendments will be applied to this version.*

### Part I: Vehicles belonging to category M<sub>1</sub>

		<p>engine speed in revolutions per minute.</p> <p>(b) An engine power output curve providing the same information may alternatively referred to.]</p>
44	Directive 92/21/EEC (Masses and dimensions)	<p>(a) The requirements of Section 3 of Annex II to Directive 92/21/EEC shall be fulfilled.</p> <p>(b) For the application of the provisions referred to in point (a), the masses to be considered are:</p> <p>— the mass in running order defined in point 2.6 of Annex I to Directive 2007/46/EC as measured by the technical service, and</p> <p>— the laden masses either stated by the vehicle manufacturer or shown on the manufacturer's plate including stickers or information available in the owner's manual. Those masses shall be deemed the technically permissible maximum laden masses.</p> <p>(c) No exemption shall be permitted in respect of the maximum</p>

<b>Part I: Vehicles belonging to category M<sub>1</sub></b>		
		permissible dimensions.
45	Directive 92/22/EEC (Safety glazing)	<p><i>Components</i></p> <p>(a) The glazing shall be made either of tempered or laminated safety glass.</p> <p>(b) Fitting of plastic glazing shall be permitted only on locations situated behind the 'B' pillar.</p> <p>(c) Glazing shall not be required to be approved under Directive 92/22/EEC.</p> <p><i>Installation</i></p> <p>(a) The installation prescriptions set out in Annex 21 to UNECE Regulation No 43 shall apply.</p> <p>(b) No tinted films which would reduce the regular light transmission under the required minimum shall be permitted on the windscreen and on the glazing located in front of the 'B' pillar.</p>
46	Directive 92/23/EEC (Tyres)	<p><i>Components</i></p> <p>Tyres shall bear an 'EC' type-approval mark including the symbol 's' (for sound).</p> <p><i>Installation</i></p> <p>(a) The dimensions, load-capacity index and speed category of the tyres shall fulfil</p>

*Status: EU Directives are being published on this site to aid cross referencing from UK legislation. After IP completion day (31 December 2020 11pm) no further amendments will be applied to this version.*

**Part I: Vehicles belonging to category M<sub>1</sub>**

		<p>the requirements of Annex IV to Directive 92/23/EEC.</p> <p>(b) The speed category symbol of the tyre shall be compatible with the maximum design speed of the vehicle.</p> <p>The presence of a speed limiter shall not exempt from the application of this requirement.</p> <p>(c) For the application of the provisions of point (b) above, the maximum speed of the vehicle shall be stated by the vehicle manufacturer. However, the technical service may assess the maximum design speed of the vehicle by using the engine maximum power output, the maximum number of revolutions per minute and the data concerning the kinematic chain.</p>
<p>50</p>	<p>Directive 94/20/EC (Couplings)</p>	<p><i>Separate technical units</i></p> <p>(a) OEM couplings intended for towing a trailer whose maximum mass does not exceed 1 500 kg shall not be required to be type-approved under Directive 94/20/EC.</p> <p>A coupling is deemed OEM equipment where it is described in the owner's manual or an equivalent supporting document</p>

---

**Part I: Vehicles belonging to category M<sub>1</sub>**

---

		<p>provided to the buyer by the vehicle manufacturer. Where such coupling is approved with the vehicle, an appropriate text shall be included in the approval certificate stating that the owner is responsible for ensuring compatibility with the coupling device fitted to the trailer.</p> <p>(b) Couplings other than those referred to in point (a) above as well as couplings that are retrofitted shall be type-approved in accordance with Directive 94/20/EC.</p> <p><i>Installation on the vehicle</i> The technical service shall check that the installation of the coupling devices comply with Annex VII to Directive 94/20/EC.</p>
53	Directive 96/79/EC (Frontal impact) (°)	<p>(a) The applicant shall submit a statement from the manufacturer establishing that the particular vehicle, [the VIN number of which has to be specified] complies with at least one of the following:</p> <ul style="list-style-type: none"> <li>— Directive 96/79/EC,</li> <li>— FMVSS No 208 (Occupant crash protection),</li> <li>— Article 18 of JSRRV.</li> </ul> <p>(b) A test in accordance with Annex II to Directive 96/79/EC may be conducted on a production vehicle at the</p>

*Status: EU Directives are being published on this site to aid cross referencing from UK legislation. After IP completion day (31 December 2020 11pm) no further amendments will be applied to this version.*

### Part I: Vehicles belonging to category M<sub>1</sub>

		<p>request of the applicant.</p> <p>The test shall be conducted by a notified European technical service which has competence therein. A detailed report shall be issued to the applicant.</p>
54	Directive 96/27/EC (Side impact)	<p>(a) The applicant shall submit a statement from the manufacturer establishing that the particular vehicle, [<i>the VIN number of which has to be specified</i>] complies with at least one of the following:</p> <ul style="list-style-type: none"> <li>— Directive 96/27/EC,</li> <li>— FMVSS No 214 (Side impact protection),</li> <li>— Article 18 of JSRRV.</li> </ul> <p>(b) A test in accordance with Section 3 of Annex II to Directive 96/27/EC may be conducted on a production vehicle at the request of the applicant.</p> <p>The test shall be conducted by a notified European technical service which has competence therein. A detailed report shall be issued to the applicant.</p>
58	Regulation (EC) No 78/2009 (Pedestrian protection)	<p><i>Brake assist</i></p> <p>Vehicles shall be fitted with an electronic antilock braking system acting on all wheels.</p> <p><i>Pedestrian protection</i></p> <p>The requirements of that Regulation shall not apply until 1 January 2013.</p> <p><i>Frontal protection systems</i></p>

*Status: EU Directives are being published on this site to aid cross referencing from UK legislation. After IP completion day (31 December 2020 11pm) no further amendments will be applied to this version.*

<b>Part I: Vehicles belonging to category M<sub>1</sub></b>		
		However, frontal protection systems installed on the vehicle shall be type-approved in accordance with Regulation (EC) No 78/2009 and their installation shall comply with the essential requirements set out in Section 6 of Annex I to that Regulation.
59	Directive 2005/64/EC (Recyclability)	The requirements of that Directive shall not apply.
61	Directive 2006/40/EC (Air-conditioning system)	The requirements of that Directive shall apply.
<b>Part II: Vehicles belonging to category N<sub>1</sub></b>		
<b>Item</b>	<b>Regulatory act reference</b>	<b>Alternative requirements</b>
1	Directive 70/157/EEC (Permissible sound level)	<p><i>Drive-by test</i></p> <p>(a) A test shall be conducted in accordance with the 'Method A' referred to in Annex 3 to UNECE Regulation No 51.</p> <p>Limits are those specified in Section 2.1 of Annex I to Directive 70/157/EEC. 1 decibel in addition to the permitted limits shall be allowed.</p> <p>(b) The test track shall comply with Annex 8 to UNECE Regulation No 51. A test track having different specifications may be used under the condition that correlation tests have been conducted by the technical service. A correction factor shall be applied if necessary.</p>

*Status: EU Directives are being published on this site to aid cross referencing from UK legislation. After IP completion day (31 December 2020 11pm) no further amendments will be applied to this version.*

## Part II: Vehicles belonging to category N<sub>1</sub>

		<p>(c) Exhaust systems containing fibrous materials need not be conditioned as prescribed in Annex 5 to UNECE Regulation No 51.</p> <p><i>Stationary test</i> A test shall be conducted in accordance with Section 3.2 of Annex 3 to UNECE Regulation No 51.</p>
2	Directive 70/220/EEC (Emissions)	<p><i>Tailpipe emissions</i></p> <p>(a) A type I test shall be conducted in accordance with Annex III to Directive 70/220/EEC using the deterioration factors referred to in point 5.3.6.2. The limits to be applied shall be those specified in point 5.3.1.4 of Annex I to that Directive.</p> <p>(b) The vehicle shall not be required to exhibit 3 000 km as requested in Section 3.1.1 of Annex III to that Directive.</p> <p>(c) The fuel to be used for the test shall be the reference fuel as prescribed in Annex IX to Directive 70/220/EEC.</p> <p>(d) The dynamometer shall be set up in accordance with the technical requirements of Section 3.2 of Appendix 2 to</p>



## Part II: Vehicles belonging to category N<sub>1</sub>

		<p>Annex III to that Directive.</p> <p>(e) The test referred to in point (a) shall not be conducted when it can be demonstrated that the vehicle complies with one of the California Regulations mentioned in the prefatory note to Section 5 of Annex I to that Directive.</p> <p><i>Evaporative emissions</i> Vehicles equipped with a petrol-fuelled engine shall be fitted with an evaporate emissions control system (e.g. a charcoal canister).</p> <p><i>Crankcase emissions</i> The presence of a device for recycling crankcase gases shall be required.</p> <p><i>OBD</i></p> <p>(a) The vehicle shall be fitted with an OBD system.</p> <p>(b) OBD-interface must be able to communicate with common diagnostic tools used for periodic technical inspections.</p>
[ <sup>F23</sup> 2a	Regulation (EC) No 715/2007 (Emissions Euro 5 and 6 light duty vehicles/access to information)	<p><i>Tailpipe emissions</i></p> <p>(a) A type I test shall be conducted in accordance with Annex III to Regulation (EC) No 692/2008 using the deterioration factors set out in point 1.4 of Annex VII to Regulation (EC) No 692/2008.</p>

*Status: EU Directives are being published on this site to aid cross referencing from UK legislation. After IP completion day (31 December 2020 11pm) no further amendments will be applied to this version.*

## Part II: Vehicles belonging to category N<sub>1</sub>

		<p>The limits to be applied shall be those specified in Table I and Table II in Annex I to Regulation (EC) No 715/2007.</p> <p>(b) The vehicle shall not be required to exhibit 3 000 km as mentioned in Section 3.1.1 of Annex 4 to UNECE Regulation No 83.</p> <p>(c) The fuel to be used for the test shall be the reference fuel as prescribed in Annex IX to Regulation (EC) No 692/2008.</p> <p>(d) The dynamometer shall be set up in accordance with the technical requirements set out in Section 3.2 of Annex 4 to UNECE Regulation No 83.</p> <p>(e) The test referred to in point (a) shall not be conducted where it can be shown that the vehicle complies with the California Regulations referred to in Section 2 of Annex I to Regulation (EC) No 692/2008.</p> <p><i>Evaporative emissions</i> For petrol-fuelled engines, the presence of an evaporate emissions control system shall be required (e.g. a charcoal canister).</p> <p><i>Crankcase emissions</i></p>
--	--	--

---

**Part II: Vehicles belonging to category N<sub>1</sub>**

---

		<p>The presence of a device for recycling crankcase gases shall be required.</p> <p><i>OBD</i></p> <p>(a) The vehicle shall be fitted with an OBD system.</p> <p>(b) OBD-interface must be able to communicate with common diagnostic tools used for periodic technical inspections.</p> <p><i>Smoke opacity</i></p> <p>(a) Vehicles equipped with a diesel-fuelled engine shall be tested in accordance with the tests methods referred to in Appendix 2 to Annex IV to Regulation (EC) No 692/2008.</p> <p>(b) The corrected value of the absorption coefficient shall be affixed conspicuously and in a readily accessible place.</p> <p><i>CO<sub>2</sub> emissions and fuel consumption</i></p> <p>(a) A test shall be conducted in accordance with Annex XII to Regulation (EC) No 692/2008.</p> <p>(b) The vehicle shall not be required to exhibit 3 000 km as requested in Section 3.1.1 of Annex 4 to UNECE Regulation No 83.</p>
--	--	---

*Status: EU Directives are being published on this site to aid cross referencing from UK legislation. After IP completion day (31 December 2020 11pm) no further amendments will be applied to this version.*

## Part II: Vehicles belonging to category N<sub>1</sub>

		<p>(c) Where the vehicle complies with the California Regulations referred to in Section 2 of Annex I to Regulation (EC) No 692/2008 and therefore no test of tailpipe emissions is required to be performed, Member States shall calculate CO<sub>2</sub> emissions and fuel consumption with the formulae laid down in the explanatory notes <sup>(b)</sup> and <sup>(c)</sup>.</p> <p><i>Access to information</i> The provisions regarding access to information shall not apply.</p> <p><i>Power measurement</i></p> <p>(a) The applicant shall submit a statement from the manufacturer stating the maximum engine power output in kW as well as the corresponding regime in revolutions per minute.</p> <p>(b) An engine power output curve providing the same information may alternatively be referred to.]</p>
3	Directive 70/221/EEC (Fuel tanks — Rear protective devices)	<p><i>Fuel tanks</i></p> <p>(a) Fuel tanks shall comply with Section 5 of Annex I to Directive</p>

---

**Part II: Vehicles belonging to category N<sub>1</sub>**

---

		<p>70/221/EEC with the exception of points 5.1, 5.2 and 5.12. In particular they shall comply with points 5.9 and 5.9.1 but no dripping test shall be conducted.</p> <p>(b) LPG or CNG tanks shall be type-approved in accordance with, respectively UNECE Regulations 67 series of amendments 01 or Regulation No 110<sup>(a)</sup>.</p> <p><i>Specific provisions for fuel tanks made of a plastic material</i></p> <p>The applicant shall submit a statement from the manufacturer establishing that the fuel tank on the particular vehicle, [<i>the VIN number of which has to be specified</i>], complies either with at least one of the following:</p> <ul style="list-style-type: none"> <li>— Section 6.3 of Directive 70/221/EEC,</li> <li>— FMVSS No 301 (Fuel system integrity),</li> <li>— Annex 5 to UNECE Regulation 34.</li> </ul> <p><i>Rear protective device</i></p> <p>(a) The rear part of the vehicle shall be constructed in accordance with section 5 of Annex II to Directive 70/221/EEC.</p>
--	--	---

*Status: EU Directives are being published on this site to aid cross referencing from UK legislation. After IP completion day (31 December 2020 11pm) no further amendments will be applied to this version.*

## Part II: Vehicles belonging to category N<sub>1</sub>

		<p>(b) For such purposes, it is sufficient that the requirements set out in the second subparagraph of point 5.2 are fulfilled.</p> <p>(c) If, in application of the above, a rear protection device has to be retrofitted, it shall comply with points 5.3 and 5.4 of Annex II to that Directive.</p>
4	Directive 70/222/EEC (Rear registration plate space)	Space, inclination, angles for visibility and position of the registration plate shall comply with Directive 70/222/EEC.
5	Directive 70/311/EEC (Steering effort)	<p><i>Mechanical systems</i></p> <p>(a) The steering mechanism shall be built as to self-centre. In order to check compliance with this provision, a test shall be conducted in accordance with points 5.1.2 and 5.2.1 of Annex I to Directive 70/311/EEC.</p> <p>(b) The failure of the power steering equipment shall not lead to a complete loss of control of the vehicle.</p> <p><i>Complex electronic vehicle control system ('Drive-by wire' devices)</i> Complex electronic control system shall be permitted only if they comply with</p>

<b>Part II: Vehicles belonging to category N<sub>1</sub></b>		
		Annex 6 to UNECE Regulation No 79.
6	Directive 70/387/EEC (Door latches and hinges)	<p>(a) Door latches and hinges shall comply with points 3.2.1, 3.3.2 and 3.4.1 of Annex I to Directive 70/387/EEC.</p> <p>(b) The requirements set out in point 3.4.1 shall not apply where compliance with point 6.1.5.4 of UNECE Regulation No 11 Rev.1 Amendment 2 is demonstrated.</p>
7	Directive 70/388/EEC (Audible warning)	<p><i>Components</i> The audible warning devices are not required to be type-approved in accordance with Directive 70/388/EEC. However, they shall emit a continuous sound as required in point 1.1 of Annex I to Directive 70/388/EEC.</p> <p><i>Installation on vehicle</i></p> <p>(a) A test shall be conducted in accordance with Section 2 of Annex I to Directive 70/388/EEC.</p> <p>(b) The maximum sound pressure level shall be in accordance with point 2.1.4 of that Annex.</p>
8	Directive 2003/97/EC (Indirect vision devices)	<p><i>Components</i></p> <p>(a) The vehicle shall be fitted with the rear-view mirrors prescribed in Section 2 of Annex</p>

*Status: EU Directives are being published on this site to aid cross referencing from UK legislation. After IP completion day (31 December 2020 11pm) no further amendments will be applied to this version.*

## Part II: Vehicles belonging to category N<sub>1</sub>

		<p>III to Directive 2003/97/EC.</p> <p>(b) They are not required to be type-approved in accordance with that Directive.</p> <p>(c) The radii of curvature of the mirrors shall not cause significant image distortions. At the discretion of the technical service, the radii of curvature shall be checked in accordance with the method described in Appendix 1 to Annex II to Directive 2003/97/EC. The radii of curvature shall not be less than those required by Section 3.4 of Annex II to that Directive.</p> <p><i>Installation on vehicle</i> Measurement shall be conducted in order to ensure that the fields of vision comply with either the provisions of Section 5 of Annex III to Directive 2003/97/EC or with Section 5 of Annex III to Directive 71/127/EEC.</p>
9	Directive 71/320/EEC (Braking)	<p><i>General provisions</i></p> <p>(a) The braking system shall be built in accordance with Section 2 of Annex I to Directive 71/320/EEC.</p> <p>(b) Vehicles shall be fitted with an electronic antilock</p>



---

**Part II: Vehicles belonging to category N<sub>1</sub>**

---

		<p>braking system acting on all wheels.</p> <p>(c) The performances of the braking system shall comply with Section 2 of Annex II to that Directive.</p> <p>(d) For these purposes, road tests shall be conducted on a track the surface of which possesses high adhesion. The test on the parking brake shall be conducted on a 18 % gradient (up and down).</p> <p>Only those tests mentioned below shall be conducted. In each case, the vehicle shall be in fully laden conditions.</p> <p>(e) The road test referred to in point (c) above shall not be conducted where the applicant can submit a statement from the manufacturer establishing that the vehicle complies either with UNECE Regulation No 13-H including supplement 5 or with FMVSS No 135.</p> <p><i>Service brake</i></p> <p>(a) A 'Type 0' test as prescribed in points 1.2.2 and 1.2.3 of Annex II to Directive 71/320/EEC shall be conducted.</p>
--	--	---

*Status: EU Directives are being published on this site to aid cross referencing from UK legislation. After IP completion day (31 December 2020 11pm) no further amendments will be applied to this version.*

## Part II: Vehicles belonging to category N<sub>1</sub>

		<p>(b) In addition, a ‘Type I’ test as prescribed in point 1.3 of Annex II to that Directive shall be conducted.</p> <p><i>Parking brake</i> A test shall be conducted in accordance with point 2.1.3 of Annex II to that Directive.</p>
10	Directive 72/245/EEC (Radio interference (electromagnetic compatibility))	<p><i>Components</i></p> <p>(a) Electrical/electronic sub-assemblies are not required to be type-approved in accordance with Directive 72/245/EEC.</p> <p>(b) However, electric/electronic devices retrofitted shall comply with that Directive.</p> <p><i>Emitted electromagnetic radiations</i> The applicant shall submit a statement from the manufacturer establishing that the vehicle complies with Directive 72/245/EEC or with the following alternative standards:</p> <ul style="list-style-type: none"> <li>— Broadband electromagnetic radiation: CISPR 12 or SAE J551-2,</li> <li>— Narrowband electromagnetic radiation: CISPR 12 (off-board) or 25 (in-board) or SAE J551-4 and SAE J1113-41.</li> </ul> <p><i>Immunity tests</i> Immunity test shall be waived.</p>

---

**Part II: Vehicles belonging to category N<sub>1</sub>**

---

11	Directive 72/306/EEC (Diesel smoke)	<p>(a) A test shall be conducted in accordance with the methods described in Annexes III and IV to Directive 72/306/EEC. The limit values applicable are those mentioned in Annex V to that Directive.</p> <p>(b) The corrected value of the absorption coefficient referred to in Section 4 of Annex I to Directive 72/306/EEC shall be affixed conspicuously and in a readily accessible place.</p>
13	Directive 74/61/EEC (Anti-theft and immobiliser)	<p>(a) In order to prevent unauthorised use, the vehicle shall be fitted with a locking device as defined in Section 2.2 of Annex IV to Directive 74/61/EEC.</p> <p>(b) If an immobiliser is fitted it shall comply with the technical requirements of Section 3 of Annex V to that Directive and the essential requirements set out in Section 4, in particular point 4.1.1.</p>
14	Directive 74/297/EEC <sup>(f)</sup> (Protective steering)	<p>(a) The applicant shall submit a statement from the manufacturer establishing that the</p>

*Status: EU Directives are being published on this site to aid cross referencing from UK legislation. After IP completion day (31 December 2020 11pm) no further amendments will be applied to this version.*

## Part II: Vehicles belonging to category N<sub>1</sub>

		<p>particular vehicle, [the VIN number of which has to be specified], complies with at least one of the following:</p> <ul style="list-style-type: none"> <li>— Directive 74/297/EEC,</li> <li>— FMVSS No 203 (Impact protection for the driver from the steering control system) including FMVSS No 204 (Steering control rearward displacement),</li> <li>— Article 11 of JSRRV.</li> </ul> <p>(b) A test in accordance with Annex II to Directive 74/297/EEC may be conducted on a production vehicle at the request of the applicant. The test shall be conducted by a notified European technical service which has competence therein. A detailed report shall be issued to the applicant.</p>
15	Directive 74/408/EEC Seats strength — head restraints	<p><i>Seats, seat anchorages and adjustment systems</i> Seats and their adjustable systems shall comply with Annex IV to Directive 74/408/EEC. <i>Head restraints</i></p> <p>(a) Head restraints shall fulfil the essential requirements of Section 3 of Annex II to Directive 74/408/EEC and Section 5 of</p>

<b>Part II: Vehicles belonging to category N<sub>1</sub></b>		
		<p>Appendix I to that Annex.</p> <p>(b) Only the tests described in point 3.10 and Sections 5, 6 and 7 of Annex II to that Directive shall be conducted.</p>
17	Directive 75/443/EEC (Speedometer — reverse gear)	<p><i>Speedometer equipment</i></p> <p>(a) The dial shall comply with points 4.1 to 4.2.3 of Annex II to Directive 75/443/EEC.</p> <p>(b) When the technical service has reasonable grounds to believe that the speedometer is not calibrated with a sufficient accuracy, it may require that the tests prescribed in Section 4.3 be conducted.</p> <p><i>Reverse gear</i> The gear mechanism shall include a reverse gear.</p>
18	Directive 76/114/EEC (Statutory plates)	<p><i>Vehicle identification number</i></p> <p>(a) The vehicle shall be fitted with a vehicle identification number comprising a minimum of 8 and a maximum of 17 characters. Vehicle identification number comprising 17 characters shall fulfil the requirements set out in Standards ISO 3779:1983 and 3780:1983.</p> <p>(b) The vehicle identification</p>

*Status: EU Directives are being published on this site to aid cross referencing from UK legislation. After IP completion day (31 December 2020 11pm) no further amendments will be applied to this version.*

## Part II: Vehicles belonging to category N<sub>1</sub>

		<p>number shall be located in a clearly visible and accessible position in such a way as it cannot be obliterated or deteriorate.</p> <p>(c) Where no vehicle identification number is stamped in the chassis or in the body, a Member State may require that it is retrofitted in application of its national law. In such a case, the competent authority of that Member State shall supervise the operation.</p> <p><i>Statutory plate</i> The vehicle shall be fitted with an identification plate affixed by the vehicle manufacturer. No additional plate shall be requested after the approval has been granted.</p>
19	Directive 76/115/EEC (Seat belt anchorages)	<p>The applicant shall submit a statement from the manufacturer establishing that the particular vehicle, [<i>the VIN number of which has to be specified</i>], complies with at least one of the following:</p> <ul style="list-style-type: none"> <li>— Directive 76/115/EEC,</li> <li>— FMVSS No 210 (Seat belt assembly anchorages),</li> <li>— Article 22-3 of JSRRV.</li> </ul>
20	Directive 76/756/EEC (Installation of lighting and light signalling devices)	<p>(a) The lighting installation shall meet the essential requirements of</p>

---

**Part II: Vehicles belonging to category N<sub>1</sub>**

---

		<p>UNECE Regulation No 48 series of amendments 03 with the exception of those of Annexes 5 and 6 to Regulation 48.</p> <p>(b) No exemption shall be permitted in respect of the number, the essential design characteristics, the electrical connections, and the colour of light emitted or retro-reflected of the lights and signalling devices referred to in Entries 21 to 26 and in Entries 28 to 30.</p> <p>(c) Lights and signalling devices which in application of the above must be retrofitted shall bear an 'EC' type-approval mark.</p> <p>(d) Lamps fitted with gas-discharged light source are only permitted in conjunction with the installation of headlamp cleaning device and an automatic headlamp-levelling device where appropriate.</p> <p>(e) Headlamp dipped-beams shall be adapted to the direction of traffic legally in force in the country</p>
--	--	---

*Status: EU Directives are being published on this site to aid cross referencing from UK legislation. After IP completion day (31 December 2020 11pm) no further amendments will be applied to this version.*

<b>Part II: Vehicles belonging to category N<sub>1</sub></b>		
		where the vehicle is granted approval.
21	Directive 76/757/EEC (Retro reflectors)	Where necessary, two additional retro reflectors bearing an 'EC' approval mark shall be added at the rear, the position of which shall comply with UNECE Regulation No 48.
22	Directive 76/758/EEC (End-outline, front position (side), rear-position (side), stop, side marker, daytime running lamps)	The requirements set out in that Directive shall not apply. However, the correct functioning of the lights shall be checked by the technical service.
23	Directive 76/759/EEC (Direction indicators)	The requirements set out in that Directive shall not apply. However, the correct functioning of the lights shall be checked by the technical service.
24	Directive 76/760/EEC (Rear registration plate lamps)	The requirements set out in that Directive shall not apply. However, the correct functioning of the lights shall be checked by the technical service.
25	Directive 76/761/EEC (Headlamps (including bulbs))	<p>(a) The illumination produced by the passing beam of the headlamps fitted to the vehicle shall be checked under the provisions of Section 6 of UNECE Regulation No 112 concerning headlamps emitting an asymmetrical passing beam. The tolerances included in Annex 5 to that Regulation may be referred to for that purpose.</p> <p>(b) The same decision shall apply <i>mutatis</i></p>



*Status: EU Directives are being published on this site to aid cross referencing from UK legislation. After IP completion day (31 December 2020 11pm) no further amendments will be applied to this version.*

<b>Part II: Vehicles belonging to category N<sub>1</sub></b>		
		<i>mutandis</i> to the passing beam of headlamps covered by UNECE Regulation No 98 or 123.
26	Directive 76/762/EEC (Front fog lamps)	The provisions of that Directive shall be waived. However, the correct functioning of the lights if fitted shall be checked by the technical service.
27	Directive 77/389/EEC (Towing hooks)	The requirements of that Directive shall be waived.
28	Directive 77/538/EEC (Rear fog lamps)	The provisions of that Directive shall be waived. However, the correct functioning of the lights shall be checked by the technical service.
29	Directive 77/539/EEC (Reversing lamps)	The provisions of that Directive shall be waived. However, the correct functioning of the lights if fitted shall be checked by the technical service.
30	Directive 77/540/EEC (Parking lamps)	The provisions of that Directive shall be waived. However, the correct functioning of the lights if fitted shall be checked by the technical service.
31	Directive 77/541/EEC (Seat belts and restraint systems)	<p><i>Components</i></p> <p>(a) Seat belts shall not be required to be type-approved in accordance with Directive 77/541/EEC.</p> <p>(b) However, each seat belt shall bear an identification label.</p> <p>(c) The indications on the label shall be consistent with the decision concerning</p>

*Status: EU Directives are being published on this site to aid cross referencing from UK legislation. After IP completion day (31 December 2020 11pm) no further amendments will be applied to this version.*

## Part II: Vehicles belonging to category N<sub>1</sub>

		<p>seat belt anchorages (Re: entry 19).</p> <p><i>Installation requirements</i></p> <p>(a) The vehicle shall be fitted with seat belts in accordance with the requirements set out in Annex XV to Directive 77/541/EEC.</p> <p>(b) Where a number of seat belts have to be retrofitted in accordance with point (a) above, they shall be of an approved type in accordance with Directive 77/541/EEC or UNECE Regulation No 16.</p>
33	Directive 78/316/EEC (Identification of controls, tell-tales and indicators)	<p>(a) The symbols including the colour of their corresponding tell-tales the presence of which is mandatory by virtue of Annex II to Directive 78/316/EEC shall comply with that Directive.</p> <p>(b) Where this is not the case, the technical service shall verify that the symbols, tell-tales and indicators fitted to the vehicle provide the driver with comprehensible information about the operation of the controls in question.</p>
34	Directive 78/317/EEC Defrost/Demist	The vehicle shall be equipped with adequate windscreen

*Status: EU Directives are being published on this site to aid cross referencing from UK legislation. After IP completion day (31 December 2020 11pm) no further amendments will be applied to this version.*

<b>Part II: Vehicles belonging to category N<sub>1</sub></b>		
		defrosting and windscreen demisting devices.
35	Directive 78/318/EEC Wash/Wipe	The vehicle shall be equipped with adequate windscreen washing and windscreen wiping devices.
36	Directive 2001/56/EC (Heating systems)	<p>(a) The passenger compartment shall be fitted with a heating system.</p> <p>(b) Combustion heaters and their installation shall comply with Annex VII to Directive 2001/56/EC. In addition, LPG combustion heaters and LPG heating systems shall fulfil the requirements set out in Annex VIII to that Directive.</p> <p>(c) Additional heating systems which are retrofitted shall comply with the requirements set out in that Directive.</p>
39	Directive 80/1268/EEC (CO <sub>2</sub> emissions/fuel consumption)	<p>(a) A test shall be conducted in accordance with Section 5 of Annex I to Directive 80/1268/EEC.</p> <p>(b) The requirements set out in point 5.1.1 of that Annex shall not apply.</p> <p>(c) Where no test concerning tailpipe emissions is conducted in application of the provisions referred</p>

*Status: EU Directives are being published on this site to aid cross referencing from UK legislation. After IP completion day (31 December 2020 11pm) no further amendments will be applied to this version.*

## Part II: Vehicles belonging to category N<sub>1</sub>

		to in Entry 2, CO <sub>2</sub> emissions and fuel consumption shall be calculated with the formula laid down in the explanatory notes <sup>(b)</sup> and <sup>(c)</sup> .
[ <sup>F26</sup> ]		
41	Directive 2005/55/EC (Emissions (Euro 4 and 5) heavy duty vehicles — OBDs — Smoke opacity)	<p><i>Tailpipe emissions</i></p> <p>(a) A test shall be conducted in accordance with Section 6.2 of Annex I to Directive 2005/55/EC using the deterioration factors set out in point 3.6 of Annex II to Directive 2005/78/EC.</p> <p>(b) The limits shall be those set out in Table I or Table 2 in Annex I to Directive 2005/55/EC.</p> <p><i>OBD</i></p> <p>(a) The vehicle shall be fitted with an OBD system.</p> <p>(b) OBD-interface must be able to communicate with common diagnostic tools used for periodic technical inspections.</p> <p><i>Smoke opacity</i></p> <p>(a) Vehicles equipped with a diesel-fuelled engine shall be tested in accordance with the tests methods referred</p>

*Status: EU Directives are being published on this site to aid cross referencing from UK legislation. After IP completion day (31 December 2020 11pm) no further amendments will be applied to this version.*

## Part II: Vehicles belonging to category N<sub>1</sub>

		<p>to in Annex VI to Directive 2005/55/EC.</p> <p>(b) The corrected value of the absorption coefficient shall be affixed conspicuously and in a readily accessible place.</p>
[ <sup>F10</sup> 41a	<p>Regulation (EC) No 595/2009 Emissions (Euro VI) heavy-duty vehicles – OBD</p>	<p><i>Tailpipe emissions</i></p> <p>(a) A test shall be conducted in accordance with Annex III to Regulation (EU) No 582/2011 using the deterioration factors set out in point 3.6.1. of Annex VI to Regulation (EU) No 582/2011.</p> <p>(b) The limits to be applied shall be those set out in the table of Annex I to Regulation (EC) No 595/2009.</p> <p>(c) The fuel to be used for the test shall be the reference fuel as prescribed in Annex IX to Regulation (EU) No 582/2011.</p> <p><i>CO<sub>2</sub> emissions</i> The CO<sub>2</sub> emissions and fuel consumption shall be determined in accordance with Annex VIII to Regulation (EU) No 582/2011.</p> <p><i>OBD</i></p> <p>(a) The vehicle shall be fitted with an OBD system.</p>

*Status: EU Directives are being published on this site to aid cross referencing from UK legislation. After IP completion day (31 December 2020 11pm) no further amendments will be applied to this version.*

## Part II: Vehicles belonging to category N<sub>1</sub>

		<p>(b) The OBD-interface must be able to communicate with an external OBD scan-tool as described in Annex X to Regulation (EU) No 582/2011.</p> <p><i>Requirements to ensure the correct operation of NO<sub>x</sub> control measures</i></p> <p>The vehicle shall be fitted with a system ensuring the correct operation of NO<sub>x</sub> control measures in accordance with Annex XIII to Regulation (EU) No 582/2011. The provisions on alternative type-approval set out in point 2.1. of that Annex shall also apply.</p> <p><i>Power measurement</i></p> <p>(a) The applicant shall submit a statement from the manufacturer stating the maximum engine power output in Kw as well as the corresponding regime</p> <p>(b) An engine power output curve providing the same information may alternatively referred to.]</p>
45	Directive 92/22/EEC (Safety glazing)	<p><i>Components</i></p> <p>(a) The glazing shall be made either of tempered or laminated safety glass.</p> <p>(b) Fitting of plastic glazing shall be permitted only on</p>

<b>Part II: Vehicles belonging to category N<sub>1</sub></b>		
		<p>locations situated behind the 'B' pillar.</p> <p>(c) Glazing shall not be required to be approved under Directive 92/22/EEC.</p> <p><i>Installation</i></p> <p>(a) The installation prescriptions set out in Annex 21 to UNECE Regulation No 43 shall apply.</p> <p>(b) No tinted films which would reduce the regular light transmission under the required minimum shall be permitted on the windscreen and on the glazing located in front of the 'B' pillar.</p>
46	Directive 92/23/EEC (Tyres)	<p><i>Components</i></p> <p>Tyres shall bear an 'EC' type-approval mark including the symbol 's' (for sound).</p> <p><i>Installation</i></p> <p>(a) The dimensions, load-capacity index and speed category of the tyres shall fulfil the requirements of Annex IV to Directive 92/23/EEC.</p> <p>(b) The speed category symbol of the tyre shall be compatible with the maximum design speed of the vehicle.</p> <p>(c) The presence of a speed limiter shall</p>

*Status: EU Directives are being published on this site to aid cross referencing from UK legislation. After IP completion day (31 December 2020 11pm) no further amendments will be applied to this version.*

## Part II: Vehicles belonging to category N<sub>1</sub>

		<p>not exempt from the application of this requirement.</p> <p>(d) For the application of the provisions of point (b) above, the maximum speed of the vehicle shall be stated by the vehicle manufacturer. However, the technical service may assess the maximum design speed of the vehicle by using the engine maximum power output, the maximum number of revolutions per minute and the data concerning the kinematic chain.</p>
48	Directive 97/27/EC (Masses and dimensions)	<p>(a) The essential requirements of Annex I to Directive 97/27/EC shall be fulfilled. However, the requirements set out in points 7.8.3, 7.9 and 7.10 of that Annex shall not apply.</p> <p>(b) For the application of the provisions of point (a) above, the masses to be considered are:</p> <ul style="list-style-type: none"> <li>— the mass in running order as defined in point 2.6 of Annex I to Directive 2007/46/EC as measured by the technical service, and</li> <li>— the maximum laden masses either stated by the vehicle manufacturer or</li> </ul>



*Status: EU Directives are being published on this site to aid cross referencing from UK legislation. After IP completion day (31 December 2020 11pm) no further amendments will be applied to this version.*

## Part II: Vehicles belonging to category N<sub>1</sub>

		<p>shown on the manufacturer's plate including stickers or information available in the owner's manual. Those masses shall be regarded as the technically permissible maximum laden masses.</p> <p>(c) Technical changes made by the applicant — such as replacing tyres with tyres with a lower load-capacity index — in order to decrease the maximum technically permissible laden mass of the vehicle to 3,5 tonnes or less in order that the vehicle may be granted individual approval shall not be permitted.</p> <p>(d) No exemption shall be permitted in respect of the maximum permissible dimensions.</p>
49	Directive 92/114/EEC (External projections of cabs)	(a) In accordance with Section 6 of Annex I to Directive 92/114/EEC, the general requirements set out in Section 5 of Annex I to Directive 74/483/EEC shall be fulfilled.

*Status: EU Directives are being published on this site to aid cross referencing from UK legislation. After IP completion day (31 December 2020 11pm) no further amendments will be applied to this version.*

## Part II: Vehicles belonging to category N<sub>1</sub>

		(b) At the discretion of the technical service the requirements set out in points 6.1, 6.5, 6.6, 6.7, 6.8 and 6.11 of Annex I to Directive 74/483/EEC shall be fulfilled.
50	Directive 94/20/EC (Couplings)	<p><i>Separate technical units</i></p> <p>(a) OEM couplings intended for towing a trailer whose maximum mass does not exceed 1 500 kg shall not be required to be type-approved under Directive 94/20/EC.</p> <p>(b) A coupling is deemed OEM equipment where it is described in the owner's manual or an equivalent supporting document provided to the buyer by the vehicle manufacturer.</p> <p>(c) Where such coupling is approved with the vehicle, an appropriate text shall be included in the approval certificate stating that the owner is responsible for ensuring compatibility with the coupling device fitted to the trailer.</p> <p>(d) Couplings other than those referred to in point (a)</p>

<b>Part II: Vehicles belonging to category N<sub>1</sub></b>		
		<p>above as well as couplings that are retrofitted shall be type-approved in accordance with Directive 94/20/EC.</p> <p><i>Installation on the vehicle</i> The technical service shall check that the installation of the coupling devices comply with Annex VII to Directive 94/20/EC.</p>
54	Directive 96/27/EC (Side impact)	<p>(a) The applicant shall submit a statement from the manufacturer establishing that the particular vehicle, [<i>the VIN number of which has to be specified</i>] complies with at least one of the following:</p> <ul style="list-style-type: none"> <li>— Directive 96/27/EC,</li> <li>— FMVSS No 214 (Side impact protection),</li> <li>— Article 18 of JSRRV.</li> </ul> <p>(b) A test in accordance with Section 3 of Annex II to Directive 96/27/EC may be conducted on a production vehicle at the request of the applicant.</p> <p>(c) The test shall be conducted by a notified European technical service which has competence thereof. A detailed report shall be issued to the applicant.</p>

*Status: EU Directives are being published on this site to aid cross referencing from UK legislation. After IP completion day (31 December 2020 11pm) no further amendments will be applied to this version.*

<b>Part II: Vehicles belonging to category N<sub>1</sub></b>		
56	Directive 98/91/EC Vehicles intended for the transport of dangerous goods	Vehicles intended for the transport of dangerous goods shall comply with Directive 94/55/EC.
58	Regulation (EC) No 78/2009 (Pedestrian protection)	<i>Brake assist</i> Vehicles shall be fitted with an electronic antilock braking system acting on all wheels. <i>Pedestrian protection</i> Until 24 February 2018, the requirements of that Regulation shall not apply to vehicles whose maximum mass does not exceed 2 500 kg and until 24 August 2019 to vehicles whose maximum mass exceeds 2 500 kg. <i>Frontal protection systems</i> However, frontal protection systems installed on the vehicle shall be type-approved in accordance with Regulation (EC) No 78/2009 and their installation shall comply with the essential requirements set out in Section 6 of Annex I to that Regulation.
59	Directive 2005/64/EC (Recyclability)	The requirements of that Directive shall not apply.
61	Directive 2006/40/EC (Air-conditioning system)	The requirements of that Directive shall apply.

#### *Explanatory notes relating to Appendix 2*

1. Abbreviations used in this Appendix:
  - ‘OEM’ : original equipment provided by the manufacturer
  - ‘FMVSS’ : Federal Motor Vehicle Safety Standard of the U.S Department of Transportation
  - ‘JSRRV’ : Japan Safety regulations for Road Vehicles
  - ‘SAE’ : Society of Automotive Engineers
  - ‘CISPR’ : Comité international spécial des perturbations radioélectriques.
2. Remarks:
  - (a) the complete LPG or CNG installation shall be checked against the provisions of UNECE Regulations No 67 or 110 or 115 as appropriate;
  - (b) the formula to be used for the assessment of CO<sub>2</sub> emissions shall be as follows:  
Petrol engine and manual gearbox:

$$\text{CO}_2 = 0,047 m + 0,561 p + 56,621$$

Petrol engine and automatic gearbox:

$$\text{CO}_2 = 0,102 m + 0,328 p + 9,481$$

Petrol engine and hybrid electric:

$$\text{CO}_2 = 0,116 m - 57,147$$

Diesel engine and manual gearbox:

$$\text{CO}_2 = 0,108 m - 11,371$$

Diesel engine and automatic gearbox:

$$\text{CO}_2 = 0,116 m - 6,432$$

Where:  $\text{CO}_2$  is the combined mass of  $\text{CO}_2$  emissions in g/km, 'm' is the mass of the vehicle in running order in kg and 'p' the maximum engine power output in kW.

Combined mass of  $\text{CO}_2$  shall be calculated with 1 decimal place, then rounded to the nearest whole number as follows:

- (a) if the figure following the decimal point is below 5, the total is rounded down;
- (b) if the figure following the decimal point is equal to 5 or above 5, the total is rounded up;
- (c) the formulæ to be used for the assessment of fuel consumption shall be as follows:

$$\text{CFC} = \text{CO}_2 \times k^{-1}$$

Where: CFC is the combined fuel consumption in l/100 km,  $\text{CO}_2$  is the combined mass of  $\text{CO}_2$  emissions in g/km after it has been rounded in accordance with the rule referred to in Remark (2 b), 'k' a coefficient equal to:

23,81 in the case of a petrol engine;

26,49 in the case of a diesel engine.

Combined fuel consumption shall be calculated with 2 decimal places. Then rounded as follows:

- (a) if the figure following the first decimal is below 5, the total is rounded down;
- (b) if the figure following the first decimal is equal to 5 or above 5, the total is rounded up;
- (d) Directive 74/297/EEC applies to vehicles which are not covered by the scope of Directive 96/79/EC;
- (e) Compliance with Directive 96/79/EC exempts vehicles from compliance with Directive 74/297/EEC;
- (f) Directive 74/297/EEC applies to  $N_1$  vehicles with a technically permissible maximum laden mass not exceeding 1,5 tonnes.]

---

*Status: EU Directives are being published on this site to aid cross referencing from UK legislation. After IP completion day (31 December 2020 11pm) no further amendments will be applied to this version.*

---

### Textual Amendments

- F20** Substituted by [Commission Regulation \(EU\) No 1229/2012 of 10 December 2012 amending Annexes IV and XII to Directive 2007/46/EC of the European Parliament and of the Council establishing a framework for the approval of motor vehicles and their trailers, and of systems, components and separate technical units intended for such vehicles \(Framework Directive\) \(Text with EEA relevance\).](#)

## PART II

### List of UNECE regulations recognised as an alternative to directives or regulations mentioned in Part I

Where reference is made to a separate Directive or Regulation in the table of Part I, an approval issued under the following UNECE Regulations to which the Community has acceded as a Contracting Party to the United Nations Economic Commission for Europe 'Revised 1958 Agreement' by virtue of Council Decision 97/836/EC<sup>(69)</sup>, or subsequent Council decisions as referred to in Article 3(3) of that Decision, shall be considered as equivalent to an EC type-approval granted under the relevant separate Directive or Regulation.

Any further amendment of the UNECE Regulations listed below<sup>(70)</sup> shall also be deemed to be equivalent, subject to the Community Decision as referred to in Article 4(2) of Decision 97/836/EC.

	Subject	Basic UNECE Regulation number	Series of amendments
1 <sup>a</sup>	Permissible sound level	51	02
	Replacement silencing systems	59	00

[<sup>F24</sup>

F24

F24

F24

F24

F24

F24

F24

F24

F24

**a** The numbering of the entries in this table refers to the numbering used in the table of Part I.

Where the separate directive or regulation contains installation requirements, these apply also to components and separate technical units approved in accordance with the UNECE Regulations.]

---

**Status:** EU Directives are being published on this site to aid cross referencing from UK legislation. After IP completion day (31 December 2020 11pm) no further amendments will be applied to this version.

F24

F24

F24

F24

F24

F24

F24

F24

F24

F24

F24

F24

F24

F24

F24

F24

F24

F24

F24

F24

F24

F24

F24

F24

F24

F24

F24

F24

F24

a The numbering of the entries in this table refers to the numbering used in the table of Part I.

Where the separate directive or regulation contains installation requirements, these apply also to components and separate technical units approved in accordance with the UNECE Regulations.]

---

*Status: EU Directives are being published on this site to aid cross referencing from UK legislation. After IP completion day (31 December 2020 11pm) no further amendments will be applied to this version.*

---

---

F24

---

F24

---

F24

---

F24

---

F24

---

F24

---

F24

---

F24

---

F24

---

F24

---

F24

---

F24

---

F24

---

F24

---

F24

---

F24

---

F24

---

F24

---

F24

---

F24

---

F24

---

F24

---

F24

---

F24

---

F24

---

F24

---

F24

---

F24

---

F24

---

a The numbering of the entries in this table refers to the numbering used in the table of Part I.

---

Where the separate directive or regulation contains installation requirements, these apply also to components and separate technical units approved in accordance with the UNECE Regulations.]

---



**Status:** EU Directives are being published on this site to aid cross referencing from UK legislation. After IP completion day (31 December 2020 11pm) no further amendments will be applied to this version.

F24			
F24			
F24			
F24			
F24]			
[ <sup>F18</sup> 58	Pedestrian protection	127	00
	Braking (brake assist)	13-H	00 (Supplement 9 and above)]

a The numbering of the entries in this table refers to the numbering used in the table of Part I.

Where the separate directive or regulation contains installation requirements, these apply also to components and separate technical units approved in accordance with the UNECE Regulations.]

## [<sup>F27</sup>ANNEX V

### PROCEDURES TO BE FOLLOWED WITH RESPECT TO EC TYPE-APPROVAL

#### Textual Amendments

**F27** Substituted by [Commission Regulation \(EU\) No 371/2010 of 16 April 2010 replacing Annexes V, X, XV and XVI to Directive 2007/46/EC of the European Parliament and of the Council establishing a framework for the approval of motor vehicles and their trailers, and of systems, components and separate technical units intended for such vehicles \(Framework Directive\) \(Text with EEA relevance\).](#)

#### 0. Objectives and scope

- 0.1. This Annex establishes the procedures for the proper operation of the vehicle type-approval in accordance with the provisions of Article 9.
- 0.2. It also includes:
  - (a) the list of international standards which are of relevance for the designation of the technical services in accordance with Article 41;
  - (b) the description of the procedure to be followed for the assessment of the skills of technical services in accordance with Article 42;
  - (c) the general requirements for the drafting of test reports by technical services.

#### 1. Type-approval process

When receiving an application for vehicle type-approval, the approval authority shall:

- (a) verify that all EC type-approval certificates issued pursuant to the regulatory acts which are applicable for vehicle type-approval cover the vehicle type and correspond to the prescribed requirements;
- (b) by reference to the documentation make sure that the vehicle specifications and data contained in Part I of the vehicle information document are included in the data in



---

**Status:** EU Directives are being published on this site to aid cross referencing from UK legislation. After IP completion day (31 December 2020 11pm) no further amendments will be applied to this version.

---

Hand of drive	X	X	X	X	X	X	—	—	—	—
Number of seats	X	X	X	X	X	X	—	—	—	—
Level of equipment	X	X	X	X	X	X	—	—	—	—

### 3. Specific provisions

Where no approval certificates for any of the relevant regulatory acts are available, the approval authority shall:

- (a) arrange for the necessary tests and checks as required by each of the relevant regulatory acts;
- (b) verify that the vehicle conforms to the particulars in the vehicle information folder and that it meets the technical requirements of each of the relevant regulatory acts;
- (c) carry out or arrange to be carried out relevant installation checks in respect of separate technical units where applicable;
- (d) carry out or arrange to be carried out necessary checks in respect of the presence of the devices provided for in footnotes (1) and (2) of Part I of Annex IV where applicable;
- (e) carry out or arrange to be carried out necessary checks in order to ensure that the requirements provided for in footnote (5) of Part I of Annex IV are fulfilled.

---

*Status: EU Directives are being published on this site to aid cross referencing from UK legislation. After IP completion day (31 December 2020 11pm) no further amendments will be applied to this version.*

---

## Appendix 1

### Standards with which the entities referred to in Article 41 have to comply

1. Activities related to testing for type-approval, to be carried out in accordance with the regulatory acts listed in Annex IV:
  - 1.1. Category A (tests performed in own facilities):

EN ISO/IEC 17025:2005 on the general requirements for the competence of testing and calibration laboratories.

A technical service designated for category A activities may carry out or supervise the tests provided for in the regulatory acts for which it has been designated, in the facilities of a manufacturer or of a third party.
  - 1.2. Category B (supervising of tests performed in the manufacturer's facilities or in the facilities of a third party):

EN ISO/IEC 17020:2004 on the general criteria for the operation of various types of bodies performing inspection.

Before performing or supervising any test in the facilities of a manufacturer or of a third party, the technical service shall check that the tests facilities and measurement devices comply with the appropriate requirements of the standard referred to in point 1.1.
2. Activities related to Conformity of Production
  - 2.1. Category C (procedure for the Initial Assessment and surveillance audits of the manufacturer's quality management system):

EN ISO/IEC 17021:2006 on the requirements for bodies providing audit and certification of management systems.
  - 2.2. Category D (inspection or testing of production samples or supervision thereof):

EN ISO/IEC 17020:2004 on the general criteria for the operation of various types of bodies performing inspection.

## Appendix 2

### Procedure for the assessment of the technical services

#### 1. Purpose of this Appendix

- 1.1. This Appendix establishes the conditions according to which the assessment procedure of the technical services shall be conducted by the competent authority referred to in Article 42.
- 1.2. These requirements shall apply *mutatis mutandis* to all technical services, irrespective of their legal status (independent organisation, manufacturer or approval authority acting as technical service).

#### 2. Principles of assessing

Assessing shall be characterised by reliance on a number of principles:

- independence which is the basis for the impartiality and objectivity of the conclusions,
- an evidence-based approach which guarantees reliable and reproducible conclusions.

Auditors shall show trust and integrity. They shall respect confidentiality and discretion.

They shall report truthfully and accurately findings and conclusions.

#### 3. Skills required of the auditors

- 3.1. The assessments may only be conducted by auditors having the technical and administrative knowledge necessary for such purposes.
- 3.2. The auditors shall have been trained specifically for assessment activities. In addition, they shall have the specific knowledge of the technical area in which the technical service will exercise its activities.
- 3.3. Without prejudice to points 3.1 and 3.2 of this Appendix, the assessment referred to in Article 42 shall be conducted by auditors independent of the activities for which the assessment is conducted.

#### 4. Application for designation

- 4.1. A duly authorised representative of the applicant technical service shall make a formal application to the competent authority that includes the following:
  - (a) general features of the technical service, including corporate entity, name, addresses, legal status and technical resources;
  - (b) a detailed description including curriculum vitae of the personnel in charge of testing and of the managerial staff as evidenced by the skills both educational and professional;
  - (c) in addition to the above, technical services which use virtual testing methods shall provide evidence of their ability to work in a Computer-Aided-x environment;
  - (d) general information concerning the technical service such as its activities, its relationship in a larger corporate entity if any, and addresses of all its physical location(s) to be covered by the scope of designation;
  - (e) an agreement to fulfil the requirements for designation and the other obligations of the technical service as applicable in the relevant Directives;

---

*Status: EU Directives are being published on this site to aid cross referencing from UK legislation. After IP completion day (31 December 2020 11pm) no further amendments will be applied to this version.*

---

- (f) a description of the conformity assessment services that the technical service undertakes in the framework of the applicable regulatory acts and a list of the regulatory acts for which the technical service applies for designation, including limits of capability where applicable;
  - (g) a copy of the quality manual of the technical service.
- 4.2. The competent authority shall review for adequacy the information supplied by the technical service.

#### 5. **Resource review**

The competent authority shall review its ability to carry out the assessment of the technical service, in terms of its own policy, its competence and the availability of suitable auditors and experts.

#### 6. **Subcontracting the assessment**

- 6.1. The competent authority may subcontract parts of the assessment to another designation authority or ask for support from technical experts provided by other competent authorities. The subcontractors and experts have to be accepted by the applicant technical service.
- 6.2. The competent authority shall take into account accreditation certificates with adequate scope in order to complete its global assessment of the technical service.

#### 7. **Preparation for assessment**

- 7.1. The competent authority shall formally appoint an assessment team. The former shall ensure that the expertise brought to each assignment is appropriate. In particular, the team as a whole:
  - (a) shall have appropriate knowledge of the specific scope for which designation is sought; and
  - (b) shall have understanding sufficient to make a reliable assessment of the competence of the technical service to operate within its scope of designation.
- 7.2. The competent authority shall clearly define the assignment given to the assessment team. The task of the assessment team is to review the documents collected from the applicant technical service and to conduct the on-site assessment.
- 7.3. The competent authority shall agree, together with the technical service and the assigned assessment team, to the date and schedule for the assessment. However, it remains the responsibility of the competent authority to pursue a date that is in accordance with the surveillance and reassessment plan.
- 7.4. The competent authority shall ensure that the assessment team is provided with the appropriate criteria documents, previous assessment records, and the relevant documents and records of the technical service.

#### 8. **On-site assessment**

The assessment team shall conduct the assessment of the technical service at the premises of the technical service from which one or more key activities are performed and, where relevant, shall perform witnessing at other selected locations where the technical service operates.

#### 9. **Analysis of findings and assessment report**

- 9.1. The assessment team shall analyse all relevant information and evidence gathered during the document and record review and the on-site assessment. This analysis shall be sufficient to allow the team to determine the extent of competence and conformity of the technical service with the requirements for designation.
- 9.2. The competent authority's reporting procedures shall ensure that the following requirements are fulfilled.
  - 9.2.1. A meeting shall take place between the assessment team and the technical service prior to leaving the site. At this meeting, the assessment team shall provide a written and/or oral report on its findings obtained from the analysis. An opportunity shall be provided for the technical service to ask questions about the findings, including non-conformities, if any, and their basis.
  - 9.2.2. A written report on the outcome of the assessment shall be promptly brought to the attention of the technical service. This assessment report shall contain comments on competence and conformity, and shall identify non-conformities, if any, to be resolved in order to conform to all of the requirements for designation.
  - 9.2.3. The technical service shall be invited to respond to the assessment report and to describe the specific actions taken or planned to be taken, within a defined time, to resolve any identified non-conformities.
- 9.3. The competent authority shall ensure that the responses of the technical service to resolve non-conformities are reviewed to see if the actions appear to be sufficient and effective. If the technical service responses are found not to be sufficient, further information shall be requested. Additionally, evidence of effective implementation of actions taken may be requested, or a follow-up assessment may be carried out to verify effective implementation of corrective actions.
- 9.4. The assessment report shall include, as a minimum the following:
  - (a) unique identification of the technical service;
  - (b) date(s) of the on-site assessment;
  - (c) name(s) of the auditors(s) and/or experts involved in the assessment;
  - (d) unique identification of all premises assessed;
  - (e) proposed scope of designation that was assessed;
  - (f) a statement on the adequacy of the internal organisation and procedures adopted by the technical service to give confidence in its competence, as determined through its fulfilment of the requirements for designation;
  - (g) information on the resolution of all non-conformities;
  - (h) a recommendation of whether the applicant should be designated or confirmed as technical service and, if so, the scope of designation.
10. **Granting/confirming a designation**
  - 10.1. The approval authority shall, without undue delay, make the decision on whether to grant, confirm or extend designation on the basis of the report(s) and any other relevant information.

---

*Status: EU Directives are being published on this site to aid cross referencing from UK legislation. After IP completion day (31 December 2020 11pm) no further amendments will be applied to this version.*

---

- 10.2. The approval authority shall provide a certificate to the technical service. This certificate shall identify the following:
- (a) the identity and logo of the approval authority;
  - (b) the unique identity of the designated technical service;
  - (c) the effective date of granting of designation and the expiry date;
  - (d) a brief indication of or a reference to the scope of designation (applicable directives, regulations or part of them);
  - (e) a statement of conformity and a reference to the present Directive.

## 11. **Reassessment and surveillance**

- 11.1. Reassessment is similar to an initial assessment except that experience gained during previous assessments shall be taken into account. Surveillance on-site assessments are less comprehensive than reassessments.
- 11.2. The competent authority shall design its plan for reassessment and surveillance of each designated technical service so that representative samples of the scope of designation are assessed on a regular basis.

The interval between on-site assessments, whether reassessment or surveillance, depends on the proven stability that the technical service has reached.

- 11.3. When, during surveillance or reassessments, non-conformities are identified, the competent authority shall define strict time limits for corrective actions to be implemented.
- 11.4. When the corrective or improvement actions have not been taken within the agreed timeframe or are not deemed to be sufficient, the competent authority shall adopt appropriate measures, such as conducting a further assessment or suspending/withdrawing the designation for one or more of the activities for which the technical service has been designated.
- 11.5. When the competent authority decides to suspend or withdraw the designation of a technical service, it shall inform the latter by registered mail. In any case, the competent authority shall adopt all the necessary measures to ensure the continuity of the activities already undertaken by the technical service.

## 12. **Records on designated technical services**

- 12.1. The competent authority shall maintain records on technical services to demonstrate that requirements for designation, including competence, have been effectively fulfilled.
- 12.2. The competent authority shall keep the records on technical services secure to ensure confidentiality.
- 12.3. Records on technical services shall include at least the following:
- (a) relevant correspondence;
  - (b) assessment records and reports;
  - (c) copies of designation certificates.



### Appendix 3

#### General requirements concerning the format of the test reports

1. For each of the regulatory acts listed in Part I of Annex IV, the test report shall comply with the provisions of Standard EN ISO/IEC 17025:2005. In particular it shall include the information mentioned in point 5.10.2, including footnote (1) of that Standard.
2. The template of the test reports shall be laid down by the approval authority in accordance with its rules of good practice.
3. The test report shall be drafted in the official language of the Community determined by the approval authority.
4. Moreover it shall include at least the following information:
  - (a) the identification of the vehicle, component or separate technical unit tested;
  - (b) a detailed description of the vehicle, component or separate technical unit characteristics in connection with the regulatory act;
  - (c) the results of the measurements specified in the relevant regulatory acts and, when required, the limits or thresholds which are to be met;
  - (d) in regard to each measurement mentioned in point 4(c) the relevant decision: passed or failed;
  - (e) a detailed statement of compliance with the various provisions which are to be met, i.e. such provisions for which it is not required to make measurements.

Example from Section 3.2.2 of Annex I to Council Directive 76/114/EEC<sup>(71)</sup>:

Check that the vehicle identification number is placed in such a way that it cannot be obliterated or deteriorate;

the report shall include a statement such as: ‘the place of stamping the vehicle identification number fulfils the requirements of Section 3.2.2 of Annex I’;

- (f) when test methods other than those prescribed in the regulatory acts are permitted the report shall include a description of the test method used for performing the test.

The same applies when alternative provisions in the regulatory acts may be used;

- (g) pictures taken during testing, the number of which shall be decided by the approval authority.

In the case of virtual testing, screen prints or other suitable evidence may replace pictures;

- (h) conclusions drawn up;
- (i) when opinions and interpretations have been made, they shall be documented properly and marked as such in the test report.

5. When the tests are conducted on a vehicle, component or technical unit that combines a number of most unfavourable features with regard to the required level of performance to be achieved (i.e. the worst-case), the test report shall include a reference stating how the selection has been made by the manufacturer in agreement with the approval authority.]

*Status: EU Directives are being published on this site to aid cross referencing from UK legislation. After IP completion day (31 December 2020 11pm) no further amendments will be applied to this version.*

## [<sup>F1</sup>ANNEX VI

### MODELS OF THE TYPE-APPROVAL CERTIFICATE

MODEL A(to be used for type-approval of a vehicle)Maximum format: A4 (210 × 297 mm)  
EC VEHICLE TYPE-APPROVAL CERTIFICATE

Stamp of type-approval authority

Communication concerning:	Of a type of:
— EC type-approval <sup>a</sup>	— complete vehicle <sup>a</sup>
— extension of EC type-approval <sup>a</sup>	— completed vehicle <sup>a</sup>
— refusal of EC type-approval <sup>a</sup>	— incomplete vehicle <sup>a</sup>
— withdrawal of EC type-approval <sup>a</sup>	— vehicle with complete and incomplete variants <sup>a</sup>
	— vehicle with completed and incomplete variants <sup>a</sup>

<sup>a</sup> Delete where not applicable.

with regard to Directive 2007/46/EC as last amended by Directive .../.../EC / Regulation (EC) No. .../...<sup>0</sup>

EC type-approval number:

Reason for extension:

SECTION 1.

I

Make (trade name of manufacturer):

0.2. Type:

0.2.1. Commercial name(s)<sup>(72)</sup>:

0.3. Means of identification of type, if marked on the vehicle:

0.3.1. Location of that marking:

0.4. Category of vehicle<sup>(73)</sup>:

0.5. Name and address of manufacturer of the complete vehicle<sup>0</sup>:

Name and address of manufacturer of the base vehicle<sup>0(74)</sup>:

Name and address of manufacturer of the latest built stage of the incomplete vehicle<sup>0(74)</sup>:

Name and address of manufacturer of the completed vehicle<sup>0(74)</sup>:

0.8. Name(s) and address(es) of assembly plant(s):

0.9. Name and address of the manufacturer's representative (if any):

SECTION II  
The undersigned hereby certifies the accuracy of the manufacturer's description in the attached information document of the vehicle(s) described above ((a) sample(s) having been selected by the EC type-approval authority and submitted by the manufacturer

---

**Status:** EU Directives are being published on this site to aid cross referencing from UK legislation. After IP completion day (31 December 2020 11pm) no further amendments will be applied to this version.

---

as prototype(s) of the vehicle type) and that the attached test results are applicable to the vehicle type.

1. For complete and completed vehicles/variants<sup>0</sup>:

The vehicle type meets/does not meet<sup>0</sup> the technical requirements of all the relevant regulatory acts as prescribed in Annex IV and Annex XI<sup>(74)</sup> to Directive 2007/46/EC.

2. For incomplete vehicles/variants<sup>0</sup>:

The vehicle type meets/does not meet<sup>0</sup> the technical requirements of the regulatory acts listed in the table on side 2.

3. The approval is granted/refused/withdrawn<sup>0</sup>.

4. The approval is granted in accordance with Article 20 and the validity of the approval is thus limited to dd/mm/yy.

(Place)	(Signature)	(Date)
---------	-------------	--------

Attachments : Information package.

Test results (see Annex VIII).

Name(s) and specimen(s) of the signature(s) of the person(s) authorised to sign certificates of conformity and a statement of their position in the company.

*NB:* If this model is used for type-approval pursuant to Articles 20, 22 or 23, it may not bear the heading 'EC Vehicle Type-Approval Certificate', except:

- in the case mentioned in Article 20 where the Commission has decided to allow a Member State to grant a type-approval in accordance with this Directive,
- in the case of vehicles of the category M<sub>1</sub>, type-approved according to the procedure prescribed in Article 22.

EC VEHICLE TYPE-APPROVAL CERTIFICATE

Side 2

This EC type-approval is, where incomplete and completed vehicles, variants or versions are concerned, based on the approval(s) for incomplete vehicles listed below:

Stage 1: Manufacturer of the base vehicle:

EC type-approval number:

Dated:

Applicable to variants or versions (as appropriate):

Stage 2: Manufacturer:

EC type-approval number:

Dated:

Applicable to variants or versions (as appropriate):

Stage 3: Manufacturer:

*Status: EU Directives are being published on this site to aid cross referencing from UK legislation. After IP completion day (31 December 2020 11pm) no further amendments will be applied to this version.*

EC type-approval number:

Dated:

Applicable to variants or versions (as appropriate):

In the case where the approval includes one or more incomplete variants or versions (as appropriate), list those variants or versions (as appropriate) which are complete or completed.

Complete/completed variant(s):

List of requirements applicable to the approved incomplete vehicle type, variant or version (as appropriate, taking account of the scope and latest amendment to each of the regulatory acts listed below).

Item	Subject	Regulatory act reference	Last amended	Applicable to variant or, if need be, to version

(List only subjects for which an EC type-approval exists.)

In the case of special purpose vehicles, exemptions granted or special provisions applied pursuant to Annex XI and exemptions granted pursuant to Article 20:

Regulatory act reference	Item number	Kind of approval and nature of exemption	Applicable to variant or, if need be, to version

Appendix List of regulatory acts to which the type of vehicle complies (to be filled in only in the case of type-approval in accordance with Article 6(3))

Subject	Regulatory act reference <sup>a</sup>	As amended by	Applicable to versions
1.	Permissible sound level	Directive 70/157/EEC	
2.	Emissions	Directive 70/220/EEC	
2a.	Emissions (Euro 5 and 6) light-duty vehicles/access to information	Regulation (EC) No 715/2007	

[<sup>F28</sup>

F28

F28

F28

<sup>a</sup> Or UNECE Regulations that are considered to be equivalent.

ANNEX VI

Document Generated: 2024-01-03

Status: EU Directives are being published on this site to aid cross referencing from UK legislation. After IP completion day (31 December 2020 11pm) no further amendments will be applied to this version.

F28

F28

F28

F28

F28

11.	Diesel smoke	Directive 72/306/EEC		
-----	--------------	----------------------	--	--

F28

F28

F28

F28

F28

F28

F28

F28

F28

F28

F28

F28

F28

F28

F28

F28

F28

F28

F28

F28

F28

F28

F28

F28

a Or UNECE Regulations that are considered to be equivalent.

*Status: EU Directives are being published on this site to aid cross referencing from UK legislation. After IP completion day (31 December 2020 11pm) no further amendments will be applied to this version.*

F28				
F28				
F28 ]				
39.	CO <sub>2</sub> emissions/ Fuel consumption	Directive 80/1268/EEC		
[ F21				
F21 ]				
[ F29	41a.	Emissions (Euro VI) heavy duty vehicles/access to information	Regulation (EC) No 595/2009	]
[ F28				
F28				
F28				
F28 ]				
46.	Tyres	Directive 92/23/EEC		
[ F28				
F28				
F28				
F28				
F28				
F28				
F28				
F28				
F28				
F28 ]				
[ F15	58.	Pedestrian protection	Regulation (EC) No 78/2009	]
59.	Recyclability	Directive 2005/64/EC		
[ F30				
a Or UNECE Regulations that are considered to be equivalent.				

**Status:** EU Directives are being published on this site to aid cross referencing from UK legislation. After IP completion day (31 December 2020 11pm) no further amendments will be applied to this version.

61.	Air-conditioning systems	Directive 2006/40/EC		
[ <sup>F31</sup> 62.	Hydrogen system	Regulation (EC) No 79/2009		]
[ <sup>F32</sup> 63.	General safety	Regulation (EC) No 661/2009		]
[ <sup>F14</sup> 63.1	Gear shift indicators	(EU) No 65/2012		]

**a** Or UNECE Regulations that are considered to be equivalent.

**Textual Amendments**

- F28** Deleted by Regulation (EC) No 661/2009 of the European Parliament and of the Council of 13 July 2009 concerning type-approval requirements for the general safety of motor vehicles, their trailers and systems, components and separate technical units intended therefor (Text with EEA relevance).
- F29** Inserted by Regulation (EC) No 595/2009 of the European Parliament and of the Council of 18 June 2009 on type-approval of motor vehicles and engines with respect to emissions from heavy duty vehicles (Euro VI) and on access to vehicle repair and maintenance information and amending Regulation (EC) No 715/2007 and Directive 2007/46/EC and repealing Directives 80/1269/EEC, 2005/55/EC and 2005/78/EC (Text with EEA relevance).
- F30** Deleted by Regulation (EC) No 78/2009 of the European Parliament and of the Council of 14 January 2009 on the type-approval of motor vehicles with regard to the protection of pedestrians and other vulnerable road users, amending Directive 2007/46/EC and repealing Directives 2003/102/EC and 2005/66/EC (Text with EEA relevance).
- F31** Inserted by Regulation (EC) No 79/2009 of the European Parliament and of the Council of 14 January 2009 on type-approval of hydrogen-powered motor vehicles, and amending Directive 2007/46/EC (Text with EEA relevance).
- F32** Inserted by Regulation (EC) No 661/2009 of the European Parliament and of the Council of 13 July 2009 concerning type-approval requirements for the general safety of motor vehicles, their trailers and systems, components and separate technical units intended therefor (Text with EEA relevance).

[<sup>F33</sup>MODEL B(To be used for type-approval of a vehicle with regard to a system)]Maximum format: A4 (210 × 297 mm)

EC TYPE-APPROVAL CERTIFICATE

Stamp of type-approval authority

Communication concerning:

—	EC type-approval <sup>a</sup>	of a type of system/type of a vehicle with regard to a system <sup>a</sup>
—	extension of EC type-approval <sup>a</sup>	
—	refusal of EC type-approval <sup>a</sup>	
—	withdrawal of EC type-approval <sup>a</sup>	

**a** Delete where not applicable.

with regard to Directive .../.../EC / Regulation (EC) No .../...<sup>0</sup>, as last amended by Directive .../.../EC / Regulation (EC) No .../...<sup>0</sup>

---

*Status: EU Directives are being published on this site to aid cross referencing from UK legislation. After IP completion day (31 December 2020 11pm) no further amendments will be applied to this version.*

---

EC type-approval number:

Reason for extension:

SECTION 1.

I

Make (trade name of manufacturer):

0.2. Type:

0.2.1. Commercial name(s) (if available):

0.3. Means of identification of type, if marked on the vehicle<sup>(75)</sup>:

0.3.1. Location of that marking:

0.4. Category of vehicle<sup>(76)</sup>:

0.5. Name and address of manufacturer:

0.8. Name(s) and address(es) of assembly plant(s):

0.9. Name and address of the manufacturer's representative (if any):

SECTION.

II

Additional information (where applicable): see Addendum.

2. Technical service responsible for carrying out the tests:

3. Date of test report:

4. Number of test report:

5. Remarks (if any): see Addendum.

6. Place:

7. Date:

8. Signature:

Attachments : Information package

Test report

Addendum to EC type-approval certificate No ...

1. Additional information

1.1. [...]:

1.1.1. [...]:

[...]

2. Type-approval number of each component or separate technical unit installed on the vehicle type to comply with this Directive or Regulation

2.1. [...]:

3. Remarks



3.1. [...]:

MODEL C (to be used for component/separate technical unit type-approval) Maximum format: A4 (210 × 297 mm)

EC TYPE-APPROVAL CERTIFICATE

Stamp of type-approval authority

Communication concerning:

—	EC type-approval <sup>a</sup>	of a type of component/separate technical unit <sup>a</sup>
—	extension of EC type-approval <sup>a</sup>	
—	refusal of EC type-approval <sup>a</sup>	
—	withdrawal of EC type-approval <sup>a</sup>	

<sup>a</sup> Delete where not applicable.

with regard to Directive .../.../EC / Regulation (EC) No .../...<sup>0</sup>, as last amended by Directive .../.../EC / Regulation (EC) No .../...<sup>0</sup>

EC type-approval number:

Reason for extension:

SECTION 1.

I

Make (trade name of manufacturer):

0.2. Type:

0.3. Means of identification of type, if marked on the component/separate technical unit<sup>(077)</sup>:

0.3.1. Location of that marking:

0.5. Name and address of manufacturer:

0.7. In the case of components and separate technical units, location and method of affixing of the EC approval mark:

0.8. Name(s) and address(es) of assembly plant(s):

0.9. Name and address of the manufacturer's representative (if any):

SECTION.

II

Additional information (where applicable): see Addendum

2. Technical service responsible for carrying out the tests:

3. Date of test report:

4. Number of test report:

5. Remarks (if any): see Addendum

6. Place:

*Status: EU Directives are being published on this site to aid cross referencing from UK legislation. After IP completion day (31 December 2020 11pm) no further amendments will be applied to this version.*

7. Date:

8. Signature:

Attachments : Information package.

Test report.

Addendum to EC type-approval certificate No ...

1. Additional information

1.1. [...]:

1.1.1. [...]:

[...]

2. Restriction of use of the device (if any)

2.1. [...]:

3. Remarks

3.1. [...]:

<sup>[F25]</sup>**MODEL D**(to be used for harmonised individual approval of a vehicle pursuant Article 24)Maximum format: A4 (210 × 297 mm)

### EC INDIVIDUAL VEHICLE APPROVAL CERTIFICATE

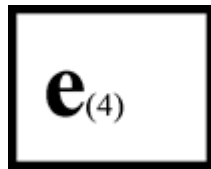

Name, address, phone number and e-mail-address of the individual approval authority

Communication concerning individual vehicle approval with regard to Article 24 of Directive 2007/46/EC

**Section** The undersigned [... ..*name and position*] hereby certifies that the vehicle:

**1**

0.1. Make (trade name of manufacturer): ...

0.2. Type:

Variant:

Version:

0.2.1. Commercial name: ...

0.4. Category of vehicle<sup>(78)</sup>: ...

0.5. Name and address of the manufacturer: ...

0.6. Location and method of attachment of the statutory plates: ...

Location of the vehicle identification number: ...

0.9. Name and address of the manufacturer's representative (if any):

0.10. Vehicle identification number:

**Status:** EU Directives are being published on this site to aid cross referencing from UK legislation. After IP completion day (31 December 2020 11pm) no further amendments will be applied to this version.

submitted for [..... date of application]  
approval on  
by [..... Name and address of the applicant]

is granted approval according to the provisions of Article 24 of Directive 2007/46/EC. In witness whereof, the following approval number has been allocated: ...

The vehicle complies with Appendix 2 to Annex IV to Directive 2007/46/EC. It can be permanently registered without further approval in Member States having right/left hand traffic<sup>(79)</sup> and using metric/imperial<sup>(79)</sup> units for the speedometer.

(Place) (Date)	(Signature <sup>a</sup> )	(Stamp of the approval authority)
[...]	[...]	[...]

**a** Or visual representation of an 'advanced electronic signature' according to Directive 1999/93/EC, including data for verification.

## Attachments

Two photos<sup>(80)</sup> of the vehicle (min resolution 640 x 480 pixel, ~7 x 10 cm)

**Section** General construction characteristics 1.

**2**

Number of axles: ... and wheels: ...

1.1.

Number and position of axles with twin wheels: ...

3.

Powered axles (number, position, interconnection): ...

## Main dimensions

4. Wheelbase<sup>(81)</sup>: ... mm

4.1. Axle spacing: 1-2: ... mm 2-3: ... mm 3-4: ... mm

5. Length: ... mm

6. Width: ... mm

7. Height: ... mm

## Masses

13. Mass of the vehicle in running order: ... kg<sup>(82)</sup>

16. Technically permissible maximum masses

16.1. Technically permissible maximum laden mass: ... kg

16.2. Technically permissible mass on each axle: 1. ... kg 2. ... kg 3. ... kg etc.

16.4. Technically permissible maximum mass of the combination: ... kg

18. Technically permissible maximum towable mass in case of:

18.1. Drawbar trailer: ... kg

18.2. Semi-trailer: ... kg

---

*Status: EU Directives are being published on this site to aid cross referencing from UK legislation. After IP completion day (31 December 2020 11pm) no further amendments will be applied to this version.*

---

- 18.3. Centre-axle trailer: ... kg
- 18.4. Unbraked trailer: ... kg
- 19. Technically permissible maximum static vertical mass at the coupling point: ... kg

#### **Power plant**

- 20. Manufacturer of the engine: ...
- 21. Engine code as marked on the engine: ...
- 22. Working principle: ...
- 23. Pure electric: yes/no<sup>(83)</sup>
- 23.1. Hybrid [electric] vehicle: yes/no<sup>(83)</sup>
- 24. Number and arrangement of cylinders: ...
- 25. Engine capacity: ... cm<sup>3</sup>
- 26. Fuel: Diesel/petrol/LPG/NG – Biomethane/Ethanol/Biodiesel/Hydrogen<sup>(83)</sup>
- 26.1. Mono fuel/Bi fuel/Flex fuel<sup>(83)</sup>
- 27. Maximum net power<sup>(84)</sup>: ... kW at ... min<sup>-1</sup> or maximum continuous rated power (electric motor) ... kW<sup>(83)</sup>

#### **Maximum speed**

- 29. Maximum speed: ... km/h

#### **Axles and suspension**

- 30. Axle(s) track: 1. ... mm 2. ... mm 3. ... mm
- 35. Tyre/wheel combination: ...

#### **Bodywork**

- 38. Code for bodywork<sup>(85)</sup>: ...
- 40. Colour of vehicle<sup>(86)</sup>: ...
- 41. Number and configuration of doors: ...
- 42. Number of seating positions (including the driver)<sup>(87)</sup>: ...
- 42.1. Seat(s) designated for use only when the vehicle is stationary: ...
- 42.3. Number of wheelchair user accessible position: ...

#### **Coupling device**

- 44. Approval number or approval mark of coupling device (if fitted): ...

#### **Environmental performances**

- 46. Sound level

Stationary: ... dB(A) at engine speed: ... min<sup>-1</sup>

Drive-by: ... dB(A)

47. Exhaust emission level<sup>(88)</sup>: Euro ...

Other legislation: ...

49. CO<sub>2</sub> emissions/fuel consumption/electric energy consumption<sup>(89)</sup>:

1. all power train except pure electric vehicles

	CO <sub>2</sub> emissions	Fuel consumption
Combined:	... g/km	... l/100 km/m <sup>3</sup> /100 km ( <sup>1</sup> )
Weighted, combined	... g/km	... l/100 km

2. pure electric vehicles and OVC hybrid electric vehicles

Electric energy consumption (weighted, combined<sup>(83)</sup>) ... Wh/km

52. Remarks

53. Additional information (mileage<sup>(90)</sup>, ...)

## [<sup>F1</sup>ANNEX VII

### EC TYPE-APPROVAL CERTIFICATE NUMBERING SYSTEM<sup>(91)</sup>

1. The EC type-approval number shall consist of four sections for whole vehicle type-approvals and five sections for system, component, and separate technical unit type-approvals as detailed below. In all cases, the sections shall be separated by the ‘\*’ character.

Section 1 : The lower case letter ‘e’ followed by the distinguishing number of the Member State issuing the EC type-approval:

1	for Germany;
2	for France;
3	for Italy;
4	for the Netherlands;
5	for Sweden;
6	for Belgium;
7	for Hungary;
8	for the Czech Republic;
9	for Spain;
11	for the United Kingdom;
12	for Austria;
13	for Luxembourg;
17	for Finland;
18	for Denmark;
19	for Romania;
20	for Poland;
21	for Portugal;
23	for Greece;

---

*Status: EU Directives are being published on this site to aid cross referencing from UK legislation. After IP completion day (31 December 2020 11pm) no further amendments will be applied to this version.*

---

- |  |                     |                |
|--|---------------------|----------------|
|  | 24                  | for Ireland;   |
|  | [ <sup>F34</sup> 25 | for Croatia;]  |
|  | 26                  | for Slovenia;  |
|  | 27                  | for Slovakia;  |
|  | 29                  | for Estonia;   |
|  | 32                  | for Latvia;    |
|  | 34                  | for Bulgaria;  |
|  | 36                  | for Lithuania; |
|  | 49                  | for Cyprus;    |
|  | 50                  | for Malta.     |
- Section 2 : The number of the base directive or regulation.
- Section 3 : [<sup>F22</sup>In case of EC type-approval for systems, components or separate technical units covered by the implementing measures of Regulation (EC) No 661/2009, the base Regulation reference shall be the Regulation number (i.e. the implementing act) adopted pursuant to Article 14(1)(a) to (e) of Regulation (EC) No 661/2009.]
- Section 3 : [<sup>F2</sup>The number of the latest amending Directive or Regulation, including implementing acts applicable to the type-approval in accordance with the following indents. However, in case such amending Directive or Regulation or applicable implementing act does not yet exist, the number referred to in Section 2 is repeated in Section 3:]
- in the case of whole vehicle type-approvals, this means the latest directive or regulation amending an Article (or Articles) of Directive 2007/46/EC,
  - in the case of whole vehicle type-approvals granted in accordance with the procedure described in Article 22, this means the latest directive or regulation amending an Article (or Articles) of Directive 2007/46/EC, except that the two first digits (e.g. 20) are replaced by the letters KS in block capitals,
  - this means the latest directive or regulation containing the actual provisions with which the system, component or technical unit conforms,
  - [<sup>F22</sup>this means the latest Regulation, containing amendments to implementing measures of Regulation (EC) No 661/2009, with which a system, component or technical unit complies,]
  - should a directive or regulation including their implementing acts contain different technical prescriptions to be applied from specific dates, Section 3 shall be followed with an alphabetical character to clearly identify against which technical prescriptions the approval was granted. When different vehicle categories are concerned, the character may also refer to a specific vehicle category.
- Section 4 : A four-digit sequential number (with leading zeros as applicable) for EC Whole vehicle type-approvals, or four or five digits for type-approval pursuant to a separate directive or regulation to denote the base type-approval number. The sequence shall start from 0001 for each base directive or regulation.
- Section 5 : A two-digit sequential number (with leading zeros if applicable) to denote the extension. The sequence shall start from 00 for each base approval number.

### Textual Amendments

**F34** Inserted by [Council Directive 2013/15/EU of 13 May 2013 adapting certain directives in the field of free movement of goods, by reason of the accession of the Republic of Croatia.](#)

2. In the case of a type-approval for a whole vehicle, Section 2 shall be omitted.

However, in the case of a national type-approval granted for vehicles produced in small series pursuant Article 23, Section 3 shall be replaced by the letters NKS in block capitals

3. On the vehicle's statutory plate(s) only, Section 5 shall be omitted.

4. Layouts of the type-approval numbers

4.1. Example of a third type-approval (which as yet no extension) issued by France

(a) to Directive 71/320/EEC:

e2\*71/320\*2002/2078\*00003\*00

(b) to Directive 2005/55/EC:

e2\*2005/2055\*2006/51 D\*00003\*00 — in the case of a directive or regulation with different technical prescriptions (see section 3)<sup>[F35]</sup>.

(c) <sup>[F22]</sup>to Commission Regulation (EU) No 1008/2010<sup>(92)</sup> (windscreen wiper and washer systems)

e2\*1008/2010\*1008/2010\*00003\*00

(d) to Commission Regulation (EU) No 19/2011<sup>(93)</sup> as amended by Commission Regulation (EU) No 249/2012<sup>(94)</sup> (statutory markings)

e2\*19/2011\*249/2012\*00003\*00]

### Textual Amendments

**F35** Deleted by [Commission Regulation \(EU\) 2015/166 of 3 February 2015 supplementing and amending Regulation \(EC\) No 661/2009 of the European Parliament and of the Council as regards the inclusion of specific procedures, assessment methods and technical requirements, and amending Directive 2007/46/EC of the European Parliament and of the Council, and Commission Regulations \(EU\) No 1003/2010, \(EU\) No 109/2011 and \(EU\) No 458/2011 \(Text with EEA relevance\).](#)

4.2. Example of the second extension to the fourth vehicle type-approval issued by the United Kingdom:

e11\*2007/2046\*0004\*02

4.3. Example of a whole vehicle type-approval granted to a vehicle produced in small series issued by Luxembourg, pursuant to Article 22:

e13\*KS07/46\*0001\*00.

4.4. Example of a national type-approval granted to a vehicle produced in small series issued by the Netherlands, pursuant to Article 23:

e4\*NKS\*0001\*00.

---

*Status: EU Directives are being published on this site to aid cross referencing from UK legislation. After IP completion day (31 December 2020 11pm) no further amendments will be applied to this version.*

---

4.5. Example of the type-approval number to be stamped on the vehicle's statutory plate(s):

e11\*2007/2046\*0004.

[<sup>F25</sup> Annex VII does not apply to type-approvals granted in accordance with UNECE Regulations listed in Annex IV, as the relevant numbering system is provided for in the respective UNECE Regulations. However, Annex VII applies to EC type-approvals granted under Regulation (EC) No 661/2009 which are based on UNECE Regulations (i.e. incorporating new technologies, EC type-approved components and STUs, virtual testing and self-testing). In this case, the following numbering system is applied:

Section 1: as above

Section 2: '661/2009' (i.e. General Safety Regulation)

Section 3: First portion is the UNECE Regulation No, followed by 'R-', the second portion is the series of amendments or '00' if it is the original series, followed by '' and the third portion is the supplement level (with leading zeroes if applicable) or '00' when there is no supplement to the relevant series.

Section 4: as above

Section 5: as above

*Examples:*

e1\*661/2009\*13-HR-10-05\*00001\*00

(granted by Germany, according to UNECE Regulation No 13-H, 10 series of amendments, supplement level 5, first approval issued, no extensions)

e25\*661/2009\*28R-00-03\*0123\*05

(granted by Croatia, according to UNECE Regulation No 28, original series of amendments, supplement 3, 123<sup>rd</sup> approval issued, 5<sup>th</sup> extension).]



## Appendix

### EC component and separate technical unit type-approval mark

1. The EC component and separate technical unit type-approval mark shall consist of:
  - 1.1. A rectangle surrounding the lower-case letter 'e' followed by the distinguishing letter(s) or number of the Member State which has granted the EC component or separate technical unit type-approval:
 

1	For Germany
2	For France
3	For Italy
4	For the Netherlands
5	For Sweden
6	For Belgium
7	For Hungary
8	For the Czech Republic
9	For Spain
11	For the United Kingdom
12	For Austria
13	For Luxembourg
17	For Finland
18	For Denmark
19	For Romania
20	For Poland
21	For Portugal
23	For Greece
24	For Ireland
[ <sup>F34</sup> 25	For Croatia]
26	For Slovenia
27	For Slovakia
29	For Estonia
32	For Latvia
34	For Bulgaria
36	For Lithuania
49	For Cyprus
50	For Malta
  - 1.2. In the vicinity of the rectangle the 'base approval number' contained in Section 4 of the type-approval number preceded by the two figures indicating the sequence number assigned to the latest major technical amendment to the relevant separate directive or regulation.
  - 1.3. An additional symbol or symbols located above the rectangle, enabling certain characteristics to be identified. This further information is specified in the relevant separate directives or regulations.
2. The component or separate technical unit type-approval mark is affixed to the separate technical unit or component in such a way as to be indelible and clearly legible.
3. An example of a component or separate technical unit type-approval mark is contained in the Addendum.

---

*Status: EU Directives are being published on this site to aid cross referencing from UK legislation. After IP completion day (31 December 2020 11pm) no further amendments will be applied to this version.*

---

[<sup>F22</sup>4. This Appendix does not apply to type-approvals granted in accordance with UNECE Regulations listed in Annex IV, as the relevant arrangements of approval marks are provided for in the respective UNECE Regulations. However, this Appendix applies to EC component and separate technical unit type-approvals granted under Regulation (EC) No 661/2009 which are based on UNECE Regulations (i.e. components or separate technical units incorporating new technologies). In this case, the following arrangement of markings is applied:

The distinguishing type-approval marking shall be as prescribed in the relevant UNECE Regulation and as if granted through conventional UNECE Regulation type-approval, however, the following shall be taken into account:

When a circle surrounding the letter 'E' is prescribed, this shall be not a circle, but a rectangle. Its height (a) shall at least correspond to the prescribed diameter size and its width shall exceed that value (i.e. > a). Instead of the upper-case letter 'E', the lower-case letter 'e' shall be used, followed by the distinguishing number of the Member State which has granted the EC component or separate technical unit type-approval.

*Example:*

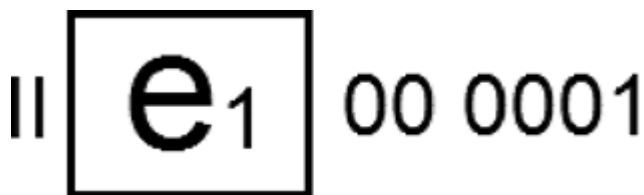

(granted by Germany, based on UNECE Regulation No 28, original series, first approval issued, for a Class II audible warning device incorporating new technologies)]

## Addendum to appendix 1

Example of a component or separate technical unit type-approval mark

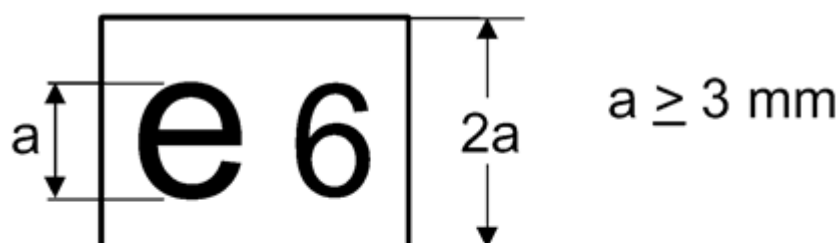

01 0004 

Legend: the above component type-approval was issued by Belgium under number 0004. 01 is a sequential number denoting the level of technical requirements to which this component fulfils. The sequential number is attributed in accordance with the relevant separate directive or regulation.

*NB:* The additional symbols are not shown on this example.]

[<sup>F36</sup>ANNEX VIII

### TEST RESULTS

#### Textual Amendments

**F36** Substituted by [Commission Regulation \(EU\) No 195/2013 of 7 March 2013 amending Directive 2007/46/EC of the European Parliament and of the Council and Commission Regulation \(EC\) No 692/2008 as concerns innovative technologies for reducing CO<sub>2</sub> emissions from light passenger and commercial vehicles \(Text with EEA relevance\).](#)

(To be completed by the type-approval authority and attached to the vehicle EC type-approval certificate)

In each case, the information must make clear to which variant and version it is applicable. One version may not have more than one result. However, a combination of several results per version indicating the worst case is permissible. In the latter case, a note shall state that for items marked (\*) only worst case results are given.

1. Results of the sound level tests

Number of the base regulatory act and latest amending regulatory act applicable to the approval. In case of a regulatory act with two or more implementation stages, indicate also the implementation stage:

*Status: EU Directives are being published on this site to aid cross referencing from UK legislation. After IP completion day (31 December 2020 11pm) no further amendments will be applied to this version.*

Variant/Version:	...	...	...
Moving (dB(A)/E):	...	...	...
Stationary (dB(A)/E):	...	...	...
at (min <sup>-1</sup> ):	...	...	...

## 2. Results of the exhaust emission tests

### 2.1. Emissions from motor vehicles tested under the test procedure for light-duty vehicles

Indicate the latest amending regulatory act applicable to the approval. In case the regulatory act has two or more implementation stages, indicate also the implementation stage:

Fuel(s)<sup>(95)</sup> ... (diesel, petrol, LPG, NG, Bi-fuel: petrol/NG, LPG, Flex-fuel: petrol/ethanol, NG/H2NG...)

#### 2.1.1. Type 1 test<sup>(96)(97)</sup> (vehicle emissions in the test cycle after a cold start)

Variant/Version:	...	...	...
CO (mg/km)	...	...	...
THC (mg/km)	...	...	...
NMHC (mg/km)	...	...	...
NO <sub>x</sub> (mg/km)	...	...	...
THC + NO <sub>x</sub> (mg/km)	...	...	...
Mass of particulate matter (PM) (mg/km)	...	...	...
Number of particles (P) (#/km) ( <sup>1</sup> )	...	...	...

#### [<sup>F</sup>2.1.2. Type 2 test<sup>(96)(97)</sup> (emissions data required at type-approval for roadworthiness purposes)

Type 2, low idle test:

Variant/Version:	...	...	...
CO (% vol.)	...	...	...
Engine speed (min <sup>-1</sup> )	...	...	...
Engine oil temperature (K)	...	...	...

Type 2, high idle test:

Variant/Version:	...	...	...
------------------	-----	-----	-----

**Status:** EU Directives are being published on this site to aid cross referencing from UK legislation. After IP completion day (31 December 2020 11pm) no further amendments will be applied to this version.

CO (% vol.)	...	...	...
Lambda Value	...	...	...
Engine speed ( $\text{min}^{-1}$ )	...	...	...
Engine oil temperature (K)	...	...	...]

2.1.3. Type 3 test (emissions of crankcase gases): ...

2.1.4. Type 4 test (evaporative emissions): ... g/test

2.1.5. Type 5 test (durability of anti-pollution control devices):

— Ageing distance covered (km)(e.g. 160 000 km): ...

— Deterioration factor DF: calculated/fixed<sup>(98)</sup>

— Values:

Variant/Version:	...	...	...
CO	...	...	...
THC	...	...	...
NMHC	...	...	...
NO <sub>x</sub>	...	...	...
THC + NO <sub>x</sub>	...	...	...
Mass of particulate matter (PM)	...	...	...
Number of particles (P) ( <sup>1</sup> )	...	...	...

2.1.6. Type 6 test (average emissions at low ambient temperatures):

Variant/Version:	...	...	...
CO (g/km)	...	...	...
THC (g/km)	...	...	...

2.2. Emissions from engines tested under the test procedure for heavy-duty vehicles.

Indicate the latest amending regulatory act applicable to the approval. In case the regulatory act has two or more implementation stages, indicate also the implementation stage:...

Fuel(s)<sup>(95)</sup> ... (diesel, petrol, LPG, NG, ethanol ...)

2.2.1. Results of the ESC test<sup>(99)(100)(101)</sup>

Variant/Version:	...	...	...
CO (mg/kWh)	...	...	...

*Status: EU Directives are being published on this site to aid cross referencing from UK legislation. After IP completion day (31 December 2020 11pm) no further amendments will be applied to this version.*

THC (mg/kWh)	...	...	...
NO <sub>x</sub> (mg/kWh)	...	...	...
NH <sub>3</sub> (ppm) <sup>(1)</sup>	...	...	...
PM mass (mg/kWh)	...	...	...
PM number (#/kWh) <sup>(1)</sup>	...	...	...

### 2.2.2. Result of the ELR test<sup>(99)</sup>

Variant/Version:	...	...	...
Smoke value: ...m <sup>-1</sup>	...	...	...

### 2.2.3. Result of the ETC test<sup>(100)(101)</sup>

Variant/Version:	...	...	...
CO (mg/kWh)	...	...	...
THC (mg/kWh)	...	...	...
NMHC (mg/kWh) <sup>(1)</sup>	...	...	...
CH <sub>4</sub> (mg/kWh) <sup>(1)</sup>	...	...	...
NO <sub>x</sub> (mg/kWh)	...	...	...
NH <sub>3</sub> (ppm) <sup>(1)</sup>	...	...	...
PM mass (mg/kWh)	...	...	...
PM number (#/kWh) <sup>(1)</sup>	...	...	...

### [<sup>F</sup>2.2.4. Idle test<sup>(99)</sup>

Variant/Version:	...	...	...
CO (% vol.)	...	...	...
Lambda Value <sup>(1)</sup>	...	...	...
Engine speed (min <sup>-1</sup> )	...	...	...
Engine oil temperature (K)	...	...	...]

### 2.3. Diesel smoke

**Status:** EU Directives are being published on this site to aid cross referencing from UK legislation. After IP completion day (31 December 2020 11pm) no further amendments will be applied to this version.

Indicate the latest amending regulatory act applicable to the approval. In case the regulatory act has two or more implementation stages, indicate also the implementation stage:

### 2.3.1. Results of the test under free acceleration

Variant/Version:	...	...	...
Corrected value of the absorption coefficient ( $m^{-1}$ )	...	...	...
Normal engine idling speed	...	...	...
Maximum engine speed	...	...	...
Oil temperature (min./max.)	...	...	...

### 3. Results of the CO<sub>2</sub> emission, fuel/electric energy consumption, and electric range tests

Number of the base regulatory act and the latest amending regulatory act applicable to the approval:

#### 3.1. Internal combustion engines, including not externally chargeable hybrid electric vehicles (NOVC)<sup>(99)(102)</sup>

Variant/Version:	...	...	...
CO <sub>2</sub> mass emission (urban conditions) (g/km)	...	...	...
CO <sub>2</sub> mass emission (extra-urban conditions) (g/km)	...	...	...
CO <sub>2</sub> mass emission (combined) (g/km)	...	...	...
Fuel consumption (urban conditions) (l/100 km) <sup>a</sup>	...	...	...
Fuel consumption (extra-urban conditions) (l/100 km) <sup>a</sup>	...	...	...
Fuel consumption (combined) (l/100 km) <sup>a</sup>	...	...	...

<sup>a</sup> The unit 'l/100 km' is replaced by 'm<sup>3</sup>/100 km' for vehicles fuelled with NG and H<sub>2</sub>NG, and by 'kg/100 km' for vehicles fuelled with hydrogen.

---

*Status: EU Directives are being published on this site to aid cross referencing from UK legislation. After IP completion day (31 December 2020 11pm) no further amendments will be applied to this version.*

---

### 3.2. Externally chargeable hybrid electric vehicles (OVC)<sup>(99)</sup>

Variant/Version:	...	...	...
CO <sub>2</sub> mass emission (Condition A, combined) (g/km)	...	...	...
CO <sub>2</sub> mass emission (Condition B, combined) (g/km)	...	...	...
CO <sub>2</sub> mass emission (weighted, combined) (g/km)	...	...	...
Fuel consumption (Condition A, combined) (l/100 km) (g)	...	...	...
Fuel consumption (Condition B, combined) (l/100 km) (g)	...	...	...
Fuel consumption (weighted, combined) (l/100 km) (g)	...	...	...
Electric energy consumption (Condition A, combined) (Wh/km)	...	...	...
Electric energy consumption (Condition B, combined) (Wh/km)	...	...	...
Electric energy consumption (weighted and combined) (Wh/km)	...	...	...
Pure electric range (km)	...	...	...

### 3.3. Pure electric vehicles<sup>(99)</sup>

Variant/Version:	...	...	...
------------------	-----	-----	-----



**Status:** EU Directives are being published on this site to aid cross referencing from UK legislation. After IP completion day (31 December 2020 11pm) no further amendments will be applied to this version.

Electric energy consumption (Wh/km)	...	...	...
Range (km)	...	...	...

3.4. Hydrogen fuel cell vehicles<sup>(99)</sup>

Variant/Version:	...	...	...
Fuel consumption (kg/100 km)	...	...	...

4. Results of the tests for vehicles fitted with eco-innovation(s)<sup>(103)(104)(105)</sup>

Variant/Version ...							
Decision approving the eco-innovation <sup>a</sup>	Code of the eco-innovation <sup>b</sup>	1.	CO <sub>2</sub> emissions of the baseline vehicle (g/km)	CO <sub>2</sub> emissions of the eco-innovation vehicle (g/km)	CO <sub>2</sub> emissions of the baseline vehicle under Type 1 test-cycle <sup>c</sup>	CO <sub>2</sub> emissions of the eco-innovation vehicle under Type 1 test-cycle (= 3.5.1.3)	CO <sub>2</sub> emissions savings factor: $(U_{((1-2)-(3-4))})*5$ i.e. temporal share of technology usage in normal operation conditions
xxxx/201x	...	...	...	...	...	...	...
...	...	...	...	...	...	...	...
...	...	...	...	...	...	...	...
Total CO <sub>2</sub> emissions savings (g/km) <sup>d</sup>							...

**a** (h4) Number of the Commission Decision approving the eco-innovation.

**b** (h5) Assigned in the Commission Decision approving the eco-innovation.

**c** (h6) If a modelling methodology is applied instead of the type 1 test cycle, this value shall be the one provided by the modelling methodology.

**d** (h7) Sum of the CO<sub>2</sub> emissions savings of each individual eco-innovation.

Explanatory notes

<sup>(h)</sup> Eco-innovations.]

---

*Status: EU Directives are being published on this site to aid cross referencing from UK legislation. After IP completion day (31 December 2020 11pm) no further amendments will be applied to this version.*

---

## [<sup>F37</sup> ANNEX IX

### EC CERTIFICATE OF CONFORMITY

#### Textual Amendments

**F37** Substituted by Commission Regulation (EC) No 385/2009 of 7 May 2009 replacing Annex IX to Directive 2007/46/EC of the European Parliament and of the Council establishing a framework for the approval of motor vehicles and their trailers, and of systems, components and separate technical units intended for such vehicles (Framework Directive) (Text with EEA relevance).

#### 0. OBJECTIVES

The certificate of conformity is a statement delivered by the vehicle manufacturer to the buyer in order to assure him that the vehicle he has acquired complies with the legislation in force in the European Union at the time it was produced.

The certificate of conformity also serves the purpose to enable the competent authorities of the Member States to register vehicles without having to require the applicant to supply additional technical documentation.

For these purposes, the certificate of conformity has to include:

- (a) the Vehicle Identification Number;
- (b) the exact technical characteristics of the vehicle (i.e. it is not permitted to mention any range of value in the various entries).

#### 1. GENERAL DESCRIPTION

- 1.1. The certificate of conformity shall consist of two parts.
  - (a) SIDE 1, which consists of a statement of compliance by the manufacturer. The same template is common to all vehicle categories.
  - (b) SIDE 2, which is a technical description of the main characteristics of the vehicle. The template of side 2 is adapted to each specific vehicle category.
- 1.2. The certificate of conformity shall be established in a maximum format A4 (210 × 297 mm) or a folder of maximum format A4.
- 1.3. Without prejudice to the provisions in Section O(b), the values and units indicated in the second part shall be those given in the type-approval documentation of the relevant regulatory acts. In case of conformity of production checks the values shall be verified according to the methods laid down in the relevant regulatory acts. The tolerances allowed in those regulatory acts shall be taken into account.

#### 2. SPECIAL PROVISIONS

- 2.1. Model A of the certificate of conformity (complete vehicle) shall cover vehicles which can be used on the road without requiring any further stage for their approval.
- 2.2. Model B of the certificate of conformity (completed vehicles) shall cover vehicles which have undergone a further stage for their approval.

This is the normal result of the multi-stage approval process (e.g. a bus built by a second stage manufacturer on a chassis built by a vehicle manufacturer).

The additional features added during the multi-stage process shall be described briefly.

- 2.3. Model C of the certificate of conformity (incomplete vehicles) shall cover vehicles which need a further stage for their approval (e.g. truck chassis).

Except for tractors for semi-trailers, certificates of conformity covering chassis-cab vehicles belonging to category N shall be of Model C.

## PART I

### COMPLETE AND COMPLETED VEHICLES

#### MODEL COMPLETE VEHICLES

A1 —

SIDE 1

EC CERTIFICATE OF CONFORMITY

**Side 1**

The undersigned [... (*Full name and position*)] hereby certifies that the vehicle:

- 0.1. Make (Trade name of manufacturer): ...
- 0.2. Type: ...
  - Variant <sup>(a)</sup>: ...
  - Version <sup>(a)</sup>: ...
- 0.2.1. Commercial name: ...
- 0.4. Vehicle category: ...
- 0.5. [<sup>F3</sup>Company name and address of manufacturer: ...]
- 0.6. Location and method of attachment of the statutory plates: ...
  - Location of the vehicle identification number: ...
- 0.9. Name and address of the manufacturer's representative (if any): ...
- 0.10. Vehicle identification number: ...

conforms in all respects to the type described in approval (... *type-approval number including extension number*) issued on (... *date of issue*) and

can be permanently registered in Member States having right/left <sup>(b)</sup> hand traffic and using metric/imperial <sup>(c)</sup> units for the speedometer <sup>(d)</sup>.

---

(Place) (Date): ...

---

(Signature): ...

---

MODEL COMPLETE VEHICLES TYPE-APPROVED IN SMALL SERIES[Year][Sequential  
A2 — number]

SIDE 1

EC CERTIFICATE OF CONFORMITY

**Side 1**

---

*Status: EU Directives are being published on this site to aid cross referencing from UK legislation. After IP completion day (31 December 2020 11pm) no further amendments will be applied to this version.*

---

The undersigned [... (*Full name and position*)] hereby certifies that the vehicle:

- 0.1. Make (Trade name of manufacturer): ...
- 0.2. Type: ...
  - Variant <sup>(a)</sup>: ...
  - Version <sup>(a)</sup>: ...
- 0.2.1. Commercial name: ...
- 0.4. Vehicle category: ...
- 0.5. [<sup>F3</sup>Company name and address of manufacturer: ...]
- 0.6. Location and method of attachment of the statutory plates: ...
  - Location of the vehicle identification number: ...
- 0.9. Name and address of the manufacturer's representative (if any): ...
- 0.10. Vehicle identification number: ...

conforms in all respects to the type described in approval (... *type-approval number including extension number*) issued on (... *date of issue*) and

can be permanently registered in Member States having right/left <sup>(b)</sup> hand traffic and using metric/imperial <sup>(c)</sup> units for the speedometer <sup>(d)</sup>.

(Place) (Date): ...	(Signature): ...
---------------------	------------------

#### MODEL COMPLETED VEHICLES

B —

SIDE 1

EC CERTIFICATE OF CONFORMITY

#### **Side 1**

The undersigned [... (*Full name and position*)] hereby certifies that the vehicle:

- 0.1. Make (Trade name of the manufacturer): ...
- 0.2. Type: ...
  - Variant <sup>(a)</sup>: ...
  - Version <sup>(a)</sup>: ...
- 0.2.1. Commercial name: ...
- 0.2.2. [<sup>F5</sup>Type-approval information of the base vehicle <sup>(q)</sup>):
  - Type: ...
  - Variant <sup>(a)</sup>: ...
  - Version <sup>(a)</sup>: ...

---

**Status:** EU Directives are being published on this site to aid cross referencing from UK legislation. After IP completion day (31 December 2020 11pm) no further amendments will be applied to this version.

---

- Type-approval number, including extension number ...]
- 0.4. Vehicle category: ...
- 0.5. [F<sup>3</sup>Company name and address of manufacturer: ...]
- 0.5.1. [F<sup>5</sup>Name and address of the manufacturer of the base vehicle <sup>(9)</sup> ...]
- 0.6. Location and method of attachment of the statutory plates: ...  
Location of the vehicle identification number: ...
- 0.9. Name and address of the manufacturer's representative (if any): ...
- 0.10. Vehicle identification number: ...
- (a) has been completed and altered <sup>(1)</sup> as follows: ... and
- (b) conforms in all respects to the type described in approval (... *type-approval number including extension number*) issued on (... *date of issue*) and
- (c) can be permanently registered in Member States having right/left <sup>(b)</sup> hand traffic and using metric/imperial <sup>(c)</sup> units for the speedometer <sup>(d)</sup>.

---

(Place) (Date): ...

---

(Signature): ...

---

Attachments: Certificate of conformity delivered at each previous stage.

SIDE 2 VEHICLE CATEGORY M<sub>1</sub>(complete and completed vehicles)

**Side 2**

**General construction characteristics**

1. Number of axles: ... and wheels: ...
3. Powered axles (number, position, interconnection): ... ..

**Main dimensions**

4. Wheelbase <sup>(c)</sup>: ... mm
- 4.1. Axle spacing:  
1-2: ... mm  
2-3: ... mm  
3-4: ... mm

5. Length: ... mm

6. Width: ... mm

7. Height: ... mm

**Masses**

[F<sup>3</sup>13. Mass in running order: ... kg]

[F<sup>4</sup>13.2. Actual mass of the vehicle: ... kg]

16. Technically permissible maximum masses

---

*Status: EU Directives are being published on this site to aid cross referencing from UK legislation. After IP completion day (31 December 2020 11pm) no further amendments will be applied to this version.*

---

- 16.1. Technically permissible maximum laden mass: ... kg
- 16.2. Technically permissible mass on each axle:
  - 1. ... kg
  - 2. ... kg
  - 3. ... kg etc.
- 16.4. Technically permissible maximum mass of the combination: ... kg
- 18. Technically permissible maximum towable mass in case of:
  - 18.1. Drawbar trailer: ... kg
  - 18.3. Centre-axle trailer: ... kg
  - 18.4. Unbraked trailer: ... kg
- 19. Technically permissible maximum static vertical mass at the coupling point: ... kg

#### **Power plant**

- 20. Manufacturer of the engine: ...
- 21. Engine code as marked on the engine: ...
- 22. Working principle: ...
- 23. Pure electric: yes/no <sup>(1)</sup>
- 23.1. Hybrid [electric] vehicle: yes/no <sup>(1)</sup>
- 24. Number and arrangement of cylinders: ...
- 25. Engine capacity: ... cm<sup>3</sup>
- [<sup>F6</sup>26. Fuel: Diesel/petrol/LPG/CNG-Biomethane/LNG/Ethanol/Biodiesel/Hydrogen <sup>(1)</sup>
- 26.1. Mono fuel/Bi fuel/Flex fuel/Dual-fuel <sup>(1)</sup>]
- 26.2. [<sup>F7</sup>(Dual-fuel only) Type 1A/Type 1B/Type 2A/Type 2B/Type 3B <sup>(1)</sup>]
- [<sup>F23</sup>27. Maximum power
- 27.1. Maximum net power (<sup>8</sup>): ... kW at ... min<sup>-1</sup> (internal combustion engine) <sup>(1)</sup>
- 27.2. Maximum hourly output: ... kW (electric motor) <sup>(1)</sup>
- 27.3. Maximum net power: ... kW (electric motor) <sup>(1)</sup>
- 27.4. Maximum 30 minutes power: ... kW (electric motor) <sup>(1)</sup>]

#### **Maximum speed**

- 29. Maximum speed: ... km/h

#### **Axles and suspension**

- 30. Axle(s) track:
  - 1. ... mm

2. ... mm

3. ... mm

35. Tyre/wheel combination (<sup>h</sup>): ...

#### **Brakes**

36. Trailer brake connections mechanical/electric/pneumatic/hydraulic (<sup>l</sup>)

#### **Bodywork**

38. Code for bodywork (<sup>i</sup>): ...

40. Colour of vehicle (<sup>j</sup>): ...

41. Number and configuration of doors: ...

42. Number of seating positions (including the driver) (<sup>k</sup>): ...

42.1. Seat(s) designated for use only when the vehicle is stationary: ...

42.3. Number of wheelchair user accessible position: ...

#### **Environmental performances**

46. Sound level

Stationary: ... dB(A) at engine speed: ... min<sup>-1</sup>

Drive-by: ... dB(A)

47. Exhaust emission level (<sup>l</sup>): Euro ...

[<sup>F6</sup>48. Exhaust emissions (<sup>m</sup>)(<sup>m1</sup>)(<sup>m2</sup>):

Number of the base regulatory act and latest amending regulatory act applicable: ...

1.1. test procedure: Type I or ESC (<sup>1</sup>)

CO: ... HC: ... NO<sub>x</sub>: ... HC + NO<sub>x</sub>: ... Particulates: ...

Smoke opacity (ELR): ... (m<sup>-1</sup>)

1.2. test procedure: Type I (Euro 5 or 6(1)) or WHSC (EURO VI) (<sup>1</sup>)

CO: ... THC: ... NMHC: ... NO<sub>x</sub>: ... THC + NO<sub>x</sub>: ... NH<sub>3</sub>: ... Particulates (mass): ...

Particles (number): ...

2.1. test procedure: ETC (if applicable)

CO: ... NO<sub>x</sub>: ... NMHC: ... THC: ... CH<sub>4</sub>: ... Particulates: ...

2.2. test procedure: WHTC (EURO VI)

CO: ... NO<sub>x</sub>: ... NMHC: ... THC: ... CH<sub>4</sub>: ... NH<sub>3</sub>: ... Particulates (mass): ... Particles (number): ...]

48.1. Smoke corrected absorption coefficient: ... (m<sup>-1</sup>)

49. CO<sub>2</sub> emissions/fuel consumption/electric energy consumption (<sup>m</sup>):

*Status: EU Directives are being published on this site to aid cross referencing from UK legislation. After IP completion day (31 December 2020 11pm) no further amendments will be applied to this version.*

1. all power train except pure electric vehicles

	CO <sub>2</sub> emissions	Fuel consumption
<b>Urban conditions:</b>	... g/km	... l/100 km/m <sup>3</sup> /100 km ( <sup>1</sup> )
<b>Extra-urban conditions:</b>	... g/km	... l/100 km/m <sup>3</sup> /100 km ( <sup>1</sup> )
<b>Combined:</b>	... g/km	... l/100 km/m <sup>3</sup> /100 km ( <sup>1</sup> )
<b>Weighted, combined</b>	... g/km	... l/100 km

2. pure electric vehicles and OVC hybrid electric vehicles

Electric energy consumption (weighted, combined)  
(<sup>1</sup>)  
Electric range ... Wh/km  
... km

3. [<sup>F36</sup>Vehicle fitted with eco-innovation(s): yes/no (<sup>1</sup>)  
3.1. General code of the eco-innovation(s) (<sup>P1</sup>): ...  
3.2. Total CO<sub>2</sub> emissions savings due to the eco-innovation(s) (<sup>P2</sup>) (repeat for each reference fuel tested): ...]

#### Miscellaneous

51. For special purpose vehicles: designation in accordance with Annex II Section 5: ...  
52. Remarks (<sup>n</sup>): ...

#### SIDE 2 VEHICLE CATEGORY M<sub>2</sub>(complete and completed vehicles)

##### Side 2

#### General construction characteristics

1. Number of axles: ... and wheels: ...  
1.1. Number and position of axles with twin wheels: ...  
2. Steered axles (number, position): ...  
3. Powered axles (number, position, interconnection): ... ..

#### Main dimensions

4. Wheelbase (<sup>e</sup>): ... mm  
4.1. Axle spacing:  
1-2: ... mm  
2-3: ... mm



3-4: ... mm

5. Length: ... mm
6. Width: ... mm
7. Height: ... mm
9. Distance between the front end of the vehicle and the centre of the coupling device:  
... mm
12. Rear overhang: ... mm

### **Masses**

- [<sup>F3</sup>13. Mass in running order: ... kg]
- 13.1. Distribution of this mass amongst the axles:
  1. ... kg
  2. ... kg
  3. ... kg etc.
- 13.2. [<sup>F4</sup>Actual mass of the vehicle: ... kg]
16. Technically permissible maximum masses
- 16.1. Technically permissible maximum laden mass: ... kg
- 16.2. Technically permissible mass on each axle:
  1. ... kg
  2. ... kg
  3. ... kg etc.
- 16.3. Technically permissible mass on each axle group:
  1. ... kg
  2. ... kg
  3. ... kg etc.
- 16.4. Technically permissible maximum mass of the combination: ... kg
17. Intended registration/in service maximum permissible masses in national/international traffic (<sup>1</sup>)(<sup>o</sup>)
- 17.1. Intended registration/in service maximum permissible laden mass: ... kg
- 17.2. Intended registration/in service maximum permissible laden mass on each axle:
  1. ... kg
  2. ... kg
  3. ... kg
- 17.3. Intended registration/in service maximum permissible laden mass on each axle group:

---

*Status: EU Directives are being published on this site to aid cross referencing from UK legislation. After IP completion day (31 December 2020 11pm) no further amendments will be applied to this version.*

---

- 1. ... kg
- 2. ... kg
- 3. ... kg
- 17.4. Intended registration/in service maximum permissible mass of the combination: ... kg
- 18. Technically permissible maximum towable mass in case of:
  - 18.1. Drawbar trailer: ... kg
  - 18.3. Centre-axle trailer: ... kg
  - 18.4. Unbraked trailer: ... kg
- 19. Technically permissible maximum static mass at the coupling point: ... kg

#### **Power plant**

- 20. Manufacturer of the engine: ...
- 21. Engine code as marked on the engine: ...
- 22. Working principle: ...
- 23. Pure electric: yes/no <sup>(1)</sup>
- 23.1. Hybrid [electric] vehicle: yes/no <sup>(1)</sup>
- 24. Number and arrangement of cylinders: ...
- 25. Engine capacity: ... cm<sup>3</sup>
- [<sup>F6</sup>26. Fuel: Diesel/petrol/LPG/CNG-Biomethane/LNG/Ethanol/Biodiesel/Hydrogen <sup>(1)</sup>
- 26.1. Mono fuel/Bi fuel/Flex fuel/Dual-fuel <sup>(1)</sup>]
- 26.2. [<sup>F7</sup>(Dual-fuel only) Type 1A/Type 1B/Type 2A/Type 2B/Type 3B <sup>(1)</sup>]
- [<sup>F23</sup>27. Maximum power
- 27.1. Maximum net power (<sup>8</sup>): ... kW at ... min<sup>-1</sup> (internal combustion engine) <sup>(1)</sup>
- 27.2. Maximum hourly output: ... kW (electric motor) <sup>(1)</sup>
- 27.3. Maximum net power: ... kW (electric motor) <sup>(1)</sup>
- 27.4. Maximum 30 minutes power: ... kW (electric motor) <sup>(1)</sup>]
- 28. Gearbox (type): ...

#### **Maximum speed**

- 29. Maximum speed: ... km/h

#### **Axles and suspension**

- 30. Axle(s) track:
  - 1. ... mm

2. ... mm

3. ... mm

33. Drive axle(s) fitted with air suspension or equivalent: yes/no <sup>(1)</sup>

35. Tyre/wheel combination <sup>(h)</sup>: ...

#### **Brakes**

36. Trailer brake connections mechanical/electric/pneumatic/hydraulic <sup>(1)</sup>

37. Pressure in feed line for trailer braking system: ... bar

#### **Bodywork**

38. Code for bodywork <sup>(i)</sup>: ...

39. Class of vehicle: class I/Class II/Class III/Class A/Class B <sup>(1)</sup>

41. Number and configuration of doors: ...

42. Number of seating positions (including the driver) <sup>(k)</sup>: ...

42.1. Seat(s) designated for use only when the vehicle is stationary: ...

42.3. Number of wheelchair user accessible position: ...

43. Number of standing places: ...

#### **Coupling device**

44. Approval number or approval mark of coupling device (if fitted): ...

45.1. Characteristics values <sup>(1)</sup>: D: .../ V: .../ S: .../ U: ...

#### **Environmental performances**

46. Sound level

Stationary: ... dB(A) at engine speed: ... min<sup>-1</sup>

Drive-by: ... dB(A)

47. Exhaust emission level <sup>(l)</sup>: Euro ...

[<sup>F6</sup>48. Exhaust emissions <sup>(m)</sup>(<sup>m1</sup>)(<sup>m2</sup>):

Number of the base regulatory act and latest amending regulatory act applicable: ...

1.1. test procedure: Type I or ESC <sup>(1)</sup>

CO: ... HC: ... NO<sub>x</sub>: ... HC + NO<sub>x</sub>: ... Particulates: ...

Smoke opacity (ELR): ... (m<sup>-1</sup>)

1.2. test procedure: Type I (Euro 5 or 6 <sup>(1)</sup>) or WHSC (EURO VI) <sup>(1)</sup>

CO: ... THC: ... NMHC: ... NO<sub>x</sub>: ... THC + NO<sub>x</sub>: ... NH<sub>3</sub>: ... Particulates (mass):  
... Particles (number): ...

2.1. test procedure: ETC (if applicable)

---

*Status: EU Directives are being published on this site to aid cross referencing from UK legislation. After IP completion day (31 December 2020 11pm) no further amendments will be applied to this version.*

---

CO: ... NO<sub>x</sub>: ... NMHC: ... THC: ... CH<sub>4</sub>: ... Particulates: ...

2.2. test procedure: WHTC (EURO VI)

CO: ... NO<sub>x</sub>: ... NMHC: ... THC: ... CH<sub>4</sub>: ... NH<sub>3</sub>: ... Particulates (mass): ... Particles (number): ...]

48.1. Smoke corrected absorption coefficient: ... (m<sup>-1</sup>)

#### **Miscellaneous**

51. For special purpose vehicles: designation in accordance with Annex II Section 5: ...

52. Remarks (<sup>n</sup>): ...

SIDE 2 VEHICLE CATEGORY M<sub>3</sub>(complete and completed vehicles)

#### **Side 2**

#### **General construction characteristics**

1. Number of axles: ... and wheels: ...

1.1. Number and position of axles with twin wheels: ...

2. Steered axles (number, position): ...

3. Powered axles (number, position, interconnection): ... ..

#### **Main dimensions**

4. Wheelbase (<sup>c</sup>): ... mm

4.1. Axle spacing:

1-2: ... mm

2-3: ... mm

3-4: ... mm

5. Length: ... mm

6. Width: ... mm

7. Height: ... mm

9. Distance between the front end of the vehicle and the centre of the coupling device: ... mm

12. Rear overhang: ... mm

#### **Masses**

[<sup>F3</sup>13. Mass in running order: ... kg]

13.1. Distribution of this mass amongst the axles:

1. ... kg

2. ... kg

3. ... kg etc.

13.2. [<sup>F4</sup>Actual mass of the vehicle: ... kg]

16. Technically permissible maximum masses
    - 16.1. Technically permissible maximum laden mass: ... kg
    - 16.2. Technically permissible mass on each axle:
      1. ... kg
      2. ... kg
      3. ... kg etc.
    - 16.3. Technically permissible mass on each axle group:
      1. ... kg
      2. ... kg
      3. ... kg etc.
    - 16.4. Technically permissible maximum mass of the combination: ... kg
  17. Intended registration/in service maximum permissible masses in national/international traffic <sup>(1)</sup>(<sup>o</sup>)
    - 17.1. Intended registration/in service maximum permissible laden mass: ... kg
    - 17.2. Intended registration/in service maximum permissible laden mass on each axle:
      1. ... kg
      2. ... kg
      3. ... kg
    - 17.3. Intended registration/in service maximum permissible laden mass on each axle group:
      1. ... kg
      2. ... kg
      3. ... kg
    - 17.4. Intended registration/in service maximum permissible mass of the combination: ... kg
  18. Technically permissible maximum towable mass in case of:
    - 18.1. Drawbar trailer: ... kg
    - 18.3. Centre-axle trailer: ... kg
    - 18.4. Unbraked trailer: ... kg
  19. Technically permissible maximum static mass at the coupling point: ... kg
- Power plant**
20. Manufacturer of the engine: ...
  21. Engine code as marked on the engine: ...
  22. Working principle: ...

---

*Status: EU Directives are being published on this site to aid cross referencing from UK legislation. After IP completion day (31 December 2020 11pm) no further amendments will be applied to this version.*

---

- 23. Pure electric: yes/no <sup>(1)</sup>
- 23.1. Hybrid [electric] vehicle: yes/no <sup>(1)</sup>
- 24. Number and arrangement of cylinders: ...
- 25. Engine capacity: ... cm<sup>3</sup>
- [<sup>F6</sup>26. Fuel: Diesel/petrol/LPG/CNG-Biomethane/LNG/Ethanol/Biodiesel/Hydrogen <sup>(1)</sup>
- 26.1. Mono fuel/Bi fuel/Flex fuel/Dual-fuel <sup>(1)</sup>]
- 26.2. [<sup>F7</sup>(Dual-fuel only) Type 1A/Type 1B/Type 2A/Type 2B/Type 3B <sup>(1)</sup>]
- [<sup>F23</sup>27. Maximum power
- 27.1. Maximum net power (<sup>g</sup>): ... kW at ... min<sup>-1</sup> (internal combustion engine) <sup>(1)</sup>
- 27.2. Maximum hourly output: ... kW (electric motor) <sup>(1)</sup>
- 27.3. Maximum net power: ... kW (electric motor) <sup>(1)</sup>
- 27.4. Maximum 30 minutes power: ... kW (electric motor) <sup>(1)</sup>]
- 28. Gearbox (type): ...

#### **Maximum speed**

- 29. Maximum speed: ... km/h

#### **Axles and suspension**

- 30.1. Track of each steered axle: ... mm
- 30.2. Track of all other axles: ... mm
- 32. Position of loadable axle(s): ...
- 33. Drive axle(s) fitted with air suspension or equivalent: yes/no <sup>(1)</sup>
- 35. Tyre/wheel combination (<sup>h</sup>): ...

#### **Brakes**

- 36. Trailer brake connections mechanical/electric/pneumatic/hydraulic <sup>(1)</sup>
- 37. Pressure in feed line for trailer braking system: ... bar

#### **Bodywork**

- 38. Code for bodywork (<sup>i</sup>): ...
- 39. Class of vehicle: class I/Class II/Class III/Class A/Class B <sup>(1)</sup>
- 41. Number and configuration of doors: ...
- 42. Number of seating positions (including the driver) (<sup>k</sup>): ...
- 42.1. Seat(s) designated for use only when the vehicle is stationary: ...

42.2. Number of passenger seating positions: ... (lower deck) ... (upper deck) (including the driver)

42.3. Number of wheelchair user accessible position: ...

43. Number of standing places: ...

#### **Coupling device**

44. Approval number or approval mark of coupling device (if fitted): ...

45.1. Characteristics values <sup>(1)</sup>: D: .../ V: .../ S: .../ U: ...

#### **Environmental performances**

46. Sound level

Stationary: ... dB(A) at engine speed: ... min<sup>-1</sup>

Drive-by: ... dB(A)

47. Exhaust emission level <sup>(1)</sup>: Euro ...

[<sup>F6</sup>48. Exhaust emissions <sup>(m)</sup>(<sup>m1</sup>)(<sup>m2</sup>):

Number of the base regulatory act and latest amending regulatory act applicable: ...

1.1. test procedure: ESC

CO: ... HC: ... NO<sub>x</sub>: ... HC + NO<sub>x</sub>: ... Particulates: ...

Smoke opacity (ELR): ... (m<sup>-1</sup>)

1.2. test procedure: WHSC (EURO VI)

CO: ... THC: ... NMHC: ... NO<sub>x</sub>: ... THC + NO<sub>x</sub>: ... NH<sub>3</sub>: ... Particulates (mass): ... Particles (number): ...

2.1. test procedure: ETC (if applicable)

CO: ... NO<sub>x</sub>: ... NMHC: ... THC: ... CH<sub>4</sub>: ... Particulates: ...

2.2. test procedure: WHTC (EURO VI)

CO: ... NO<sub>x</sub>: ... NMHC: ... THC: ... CH<sub>4</sub>: ... NH<sub>3</sub>: ... Particulates (mass): ... Particles (number): ...]

48.1. Smoke corrected absorption coefficient: ... (m<sup>-1</sup>)

#### **Miscellaneous**

51. For special purpose vehicles: designation in accordance with Annex II Section 5: ...

52. Remarks <sup>(n)</sup>: ...

SIDE 2 VEHICLE CATEGORY N<sub>1</sub>(complete and completed vehicles)

#### **Side 2**

#### **General construction characteristics**

1. Number of axles: ... and wheels: ...

1.1. Number and position of axles with twin wheels: ...

---

*Status: EU Directives are being published on this site to aid cross referencing from UK legislation. After IP completion day (31 December 2020 11pm) no further amendments will be applied to this version.*

---

3. Powered axles (number, position, interconnection): ... ..

**Main dimensions**

4. Wheelbase (°): ... mm

4.1. Axle spacing:

1-2: ... mm

2-3: ... mm

3-4: ... mm

5. Length: ... mm

6. Width: ... mm

7. Height: ... mm

8. Fifth wheel lead for semi-trailer towing vehicle (maximum and minimum): ... mm

9. Distance between the front end of the vehicle and the centre of the coupling device:  
... mm

11. Length of the loading area: ... mm

**Masses**

[<sup>F3</sup>13. Mass in running order: ... kg]

13.1. Distribution of this mass amongst the axles:

1. ... kg

2. ... kg

3. ... kg

13.2. [<sup>F4</sup>Actual mass of the vehicle: ... kg]

[<sup>F5</sup>14. Mass of the base vehicle in running order: ... kg (<sup>1</sup>)(<sup>9</sup>)]

16. Technically permissible maximum masses

16.1. Technically permissible maximum laden mass: ... kg

16.2. Technically permissible mass on each axle:

1. ... kg

2. ... kg

3. ... kg etc.

16.4. Technically permissible maximum mass of the combination: ... kg

18. Technically permissible maximum towable mass in case of:

18.1. Drawbar trailer: ... kg

18.2. Semi-trailer: ... kg

18.3. Centre-axle trailer: ... kg



18.4. Unbraked trailer: ... kg

19. Technically permissible maximum static mass at the coupling point: ... kg

#### **Power plant**

20. Manufacturer of the engine: ...

21. Engine code as marked on the engine: ...

22. Working principle: ...

23. Pure electric: yes/no <sup>(1)</sup>

23.1. Hybrid [electric] vehicle: yes/no <sup>(1)</sup>

24. Number and arrangement of cylinders: ...

25. Engine capacity: ... cm<sup>3</sup>

[<sup>F6</sup>26. Fuel: Diesel/petrol/LPG/CNG-Biomethane/LNG/Ethanol/Biodiesel/Hydrogen <sup>(1)</sup>

26.1. Mono fuel/Bi fuel/Flex fuel/Dual-fuel <sup>(1)</sup>]

26.2. [<sup>F7</sup>(Dual-fuel only) Type 1A/Type 1B/Type 2A/Type 2B/Type 3B <sup>(1)</sup>]

[<sup>F23</sup>27. Maximum power

27.1. Maximum net power (<sup>g</sup>): ... kW at ... min<sup>-1</sup> (internal combustion engine) <sup>(1)</sup>

27.2. Maximum hourly output: ... kW (electric motor) <sup>(1)</sup>

27.3. Maximum net power: ... kW (electric motor) <sup>(1)</sup>

27.4. Maximum 30 minutes power: ... kW (electric motor) <sup>(1)</sup>]

28. Gearbox (type): ...

#### **Maximum speed**

29. Maximum speed: ... km/h

#### **Axles and suspension**

30. Axle(s) track:

1. ... mm

2. ... mm

3. ... mm

35. Tyre/wheel combination (<sup>h</sup>): ...

#### **Brakes**

36. Trailer brake connections mechanical/electric/pneumatic/hydraulic <sup>(1)</sup>

37. Pressure in feed line for trailer braking system: ... bar

#### **Bodywork**

38. Code for bodywork (<sup>i</sup>): ...

---

*Status: EU Directives are being published on this site to aid cross referencing from UK legislation. After IP completion day (31 December 2020 11pm) no further amendments will be applied to this version.*

---

40. Colour of vehicle <sup>(j)</sup>: ...
41. Number and configuration of doors: ...
42. Number of seating positions (including the driver) <sup>(k)</sup>: ...

#### **Coupling device**

44. Approval number or approval mark of coupling device (if fitted): ...
- 45.1. Characteristics values <sup>(l)</sup>: D: .../ V: .../ S: .../ U: ...

#### **Environmental performances**

46. Sound level

Stationary: ... dB(A) at engine speed: ... min<sup>-1</sup>

Drive-by: ... dB(A)

47. Exhaust emission level <sup>(l)</sup>: Euro ...

[<sup>F6</sup>48. Exhaust emissions <sup>(m)</sup>(<sup>m1</sup>)(<sup>m2</sup>):

Number of the base regulatory act and latest amending regulatory act applicable: ...

- 1.1. test procedure: Type I or ESC <sup>(l)</sup>

CO: ... HC: ... NO<sub>x</sub>: ... HC + NO<sub>x</sub>: ... Particulates: ...

Smoke opacity (ELR): ... (m<sup>-1</sup>)

- 1.2. test procedure: Type I (Euro 5 or 6 (1)) or WHSC (EURO VI) <sup>(l)</sup>

CO: ... THC: ... NMHC: ... NO<sub>x</sub>: ... THC + NO<sub>x</sub>: ... NH<sub>3</sub>: ... Particulates (mass): ... Particles (number): ...

- 2.1. test procedure: ETC (if applicable)

CO: ... NO<sub>x</sub>: ... NMHC: ... THC: ... CH<sub>4</sub>: ... Particulates: ...

- 2.2. test procedure: WHTC (EURO VI)

CO: ... NO<sub>x</sub>: ... NMHC: ... THC: ... CH<sub>4</sub>: ... NH<sub>3</sub>: ... Particulates (mass): ... Particles (number): ...]

- 48.1. Smoke corrected absorption coefficient: ... (m<sup>-1</sup>)

49. CO<sub>2</sub> emissions/fuel consumption/electric energy consumption <sup>(m)</sup>:

1. all power train except pure electric vehicles

	<b>CO<sub>2</sub> emissions</b>	<b>Fuel consumption</b>
<b>Urban conditions:</b>	... g/km	... l/100 km/m <sup>3</sup> /100 km <sup>(l)</sup>

**Status:** EU Directives are being published on this site to aid cross referencing from UK legislation. After IP completion day (31 December 2020 11pm) no further amendments will be applied to this version.

<b>Extra-urban conditions:</b>	... g/km	... l/100 km/m <sup>3</sup> /100 km ( <sup>1</sup> )
<b>Combined:</b>	... g/km	... l/100 km/m <sup>3</sup> /100 km ( <sup>1</sup> )
<b>Weighted, combined</b>	... g/km	... l/100 km

2. pure electric vehicles and OVC hybrid electric vehicles

Electric energy consumption (weighted, combined)  
(<sup>1</sup>)  
Electric range ... Wh/km ... km

3. [<sup>F38</sup>Vehicle fitted with eco-innovation(s): yes/no (<sup>1</sup>)

3.1. General code of the eco-innovation(s) (<sup>P1</sup>): ...

3.2. Total CO<sub>2</sub> emissions saving due to the eco-innovation(s) (<sup>P2</sup>) (repeat for each reference fuel tested): ...]

#### Textual Amendments

**F38** Inserted by [Commission Regulation \(EU\) 2015/45 of 14 January 2015 amending Directive 2007/46/EC of the European Parliament and of the Council and Commission Regulation \(EC\) No 692/2008 as regards innovative technologies for reducing CO<sub>2</sub> emissions from light commercial vehicles \(Text with EEA relevance\).](#)

#### Miscellaneous

50. Type-approved according to the design requirements for transporting dangerous goods: yes/class(es): .../no (<sup>1</sup>):

51. For special purpose vehicles: designation in accordance with Annex II Section 5: ...

52. Remarks (<sup>n</sup>): ...

SIDE 2 VEHICLE CATEGORY N<sub>2</sub>(complete and completed vehicles)

#### Side 2

#### General construction characteristics

1. Number of axles: ... and wheels: ...

1.1. Number and position of axles with twin wheels: ...

2. Steered axles (number, position): ...

3. Powered axles (number, position, interconnection): ... ..

#### Main dimensions

4. Wheelbase (<sup>c</sup>): ... mm

---

*Status: EU Directives are being published on this site to aid cross referencing from UK legislation. After IP completion day (31 December 2020 11pm) no further amendments will be applied to this version.*

---

- 4.1. Axle spacing:
  - 1-2: ... mm
  - 2-3: ... mm
  - 3-4: ... mm
- 5. Length: ... mm
- 6. Width: ... mm
- 8. Fifth wheel lead for semi-trailer towing vehicle (maximum and minimum): ... mm
- 9. Distance between the front end of the vehicle and the centre of the coupling device: ... mm
- 11. Length of the loading area: ... mm
- 12. Rear overhang: ... mm
- Masses**
- [<sup>F3</sup>13. Mass in running order: ... kg]
- 13.1. Distribution of this mass amongst the axles:
  - 1. ... kg
  - 2. ... kg
  - 3. ... kg
- 13.2. [<sup>F4</sup>Actual mass of the vehicle: ... kg]
- 16. Technically permissible maximum masses
- 16.1. Technically permissible maximum laden mass: ... kg
- 16.2. Technically permissible mass on each axle:
  - 1. ... kg
  - 2. ... kg
  - 3. ... kg etc.
- 16.3. Technically permissible mass on each axle group:
  - 1. ... kg
  - 2. ... kg
  - 3. ... kg etc.
- 16.4. Technically permissible maximum mass of the combination: ... kg
- 17. Intended registration/in service maximum permissible masses in national/international traffic (<sup>1</sup>)(<sup>0</sup>)
- 17.1. Intended registration/in service maximum permissible laden mass: ... kg
- 17.2. Intended registration/in service maximum permissible laden mass on each axle:
  - 1. ... kg

---

**Status:** EU Directives are being published on this site to aid cross referencing from UK legislation. After IP completion day (31 December 2020 11pm) no further amendments will be applied to this version.

---

- 2. ... kg
  - 3. ... kg
  - 17.3. Intended registration/in service maximum permissible laden mass on each axle group:
    - 1. ... kg
    - 2. ... kg
    - 3. ... kg
  - 17.4. Intended registration/in service maximum permissible mass of the combination: ... kg
  - 18. Technically permissible maximum towable mass in case of:
    - 18.1. Drawbar trailer: ... kg
    - 18.2. Semi-trailer: ... kg
    - 18.3. Centre-axle trailer: ... kg
    - 18.4. Unbraked trailer: ... kg
  - 19. Technically permissible maximum static mass at the coupling point: ... kg
- Power plant**
- 20. Manufacturer of the engine: ...
  - 21. Engine code as marked on the engine: ...
  - 22. Working principle: ...
  - 23. Pure electric: yes/no <sup>(1)</sup>
  - 23.1. Hybrid [electric] vehicle: yes/no <sup>(1)</sup>
  - 24. Number and arrangement of cylinders: ...
  - 25. Engine capacity: ... cm<sup>3</sup>
  - [<sup>F6</sup>26. Fuel: Diesel/petrol/LPG/CNG-Biomethane/LNG/Ethanol/Biodiesel/Hydrogen <sup>(1)</sup>
  - 26.1. Mono fuel/Bi fuel/Flex fuel/Dual-fuel <sup>(1)</sup>]
  - 26.2. [<sup>F7</sup>(Dual-fuel only) Type 1A/Type 1B/Type 2A/Type 2B/Type 3B <sup>(1)</sup>]
  - [<sup>F23</sup>27. Maximum power
  - 27.1. Maximum net power <sup>(8)</sup>: ... kW at ... min<sup>-1</sup> (internal combustion engine) <sup>(1)</sup>
  - 27.2. Maximum hourly output: ... kW (electric motor) <sup>(1)</sup>
  - 27.3. Maximum net power: ... kW (electric motor) <sup>(1)</sup>
  - 27.4. Maximum 30 minutes power: ... kW (electric motor) <sup>(1)</sup>]
  - 28. Gearbox (type): ...
- Maximum speed**

---

*Status: EU Directives are being published on this site to aid cross referencing from UK legislation. After IP completion day (31 December 2020 11pm) no further amendments will be applied to this version.*

---

29. Maximum speed: ... km/h

### **Axles and suspension**

[<sup>F16</sup>31. Position of lift axle(s): ...]

32. Position of loadable axle(s): ...

33. Drive axle(s) fitted with air suspension or equivalent: yes/no (<sup>l</sup>)

35. Tyre/wheel combination (<sup>h</sup>): ...

### **Brakes**

36. Trailer brake connections mechanical/electric/pneumatic/hydraulic (<sup>l</sup>)

37. Pressure in feed line for trailer braking system: ... bar

### **Bodywork**

38. Code for bodywork (<sup>i</sup>): ...

41. Number and configuration of doors: ...

42. Number of seating positions (including the driver) (<sup>k</sup>): ...

### **Coupling device**

44. Approval number or approval mark of coupling device (if fitted): ...

45.1. Characteristics values (<sup>l</sup>): D: .../ V: .../ S: .../ U: ...

### **Environmental performances**

46. Sound level

Stationary: ... dB(A) at engine speed: ... min<sup>-1</sup>

Drive-by: ... dB(A)

47. Exhaust emission level (<sup>l</sup>): Euro ...

[<sup>F6</sup>48. Exhaust emissions (<sup>m</sup>)(<sup>m1</sup>)(<sup>m2</sup>):

Number of the base regulatory act and latest amending regulatory act applicable: ...

1.1. test procedure: Type I or ESC (<sup>l</sup>)

CO: ... HC: ... NO<sub>x</sub>: ... HC + NO<sub>x</sub>: ... Particulates: ...

Smoke opacity (ELR): ... (m<sup>-1</sup>)

1.2. test procedure: Type I (Euro 5 or 6 (1)) or WHSC (EURO VI) (<sup>l</sup>)

CO: ... THC: ... NMHC: ... NO<sub>x</sub>: ... THC + NO<sub>x</sub>: ... NH<sub>3</sub>: ... Particulates (mass):  
... Particles (number): ...

2.1. test procedure: ETC (if applicable)

CO: ... NO<sub>x</sub>: ... NMHC: ... THC: ... CH<sub>4</sub>: ... Particulates: ...

2.2. test procedure: WHTC (EURO VI)

CO: ... NO<sub>x</sub>: ... NMHC: ... THC: ... CH<sub>4</sub>: ... NH<sub>3</sub>: ... Particulates (mass): ... Particles (number): ...]

48.1. Smoke corrected absorption coefficient: ... (m<sup>-1</sup>)

#### **Miscellaneous**

50. Type-approved according to the design requirements for transporting dangerous goods: yes/class(es): .../no (<sup>1</sup>):

51. For special purpose vehicles: designation in accordance with Annex II Section 5: ...

52. Remarks (<sup>n</sup>): ...

SIDE 2 VEHICLE CATEGORY N<sub>3</sub>(complete and completed vehicles)

#### **Side 2**

#### **General construction characteristics**

1. Number of axles: ... and wheels: ...

1.1. Number and position of axles with twin wheels: ...

2. Steered axles (number, position): ...

3. Powered axles (number, position, interconnection): ... ..

#### **Main dimensions**

4. Wheelbase (<sup>e</sup>): ... mm

4.1. Axle spacing:

1-2: ... mm

2-3: ... mm

3-4: ... mm

5. Length: ... mm

6. Width: ... mm

8. Fifth wheel lead for semi-trailer towing vehicle (maximum and minimum): ... mm

9. Distance between the front end of the vehicle and the centre of the coupling device: ... mm

11. Length of the loading area: ... mm

12. Rear overhang: ... mm

#### **Masses**

[<sup>F3</sup>13. Mass in running order: ... kg]

13.1. Distribution of this mass amongst the axles:

1. ... kg

2. ... kg

3. ... kg

13.2. [<sup>F4</sup>Actual mass of the vehicle: ... kg]

---

*Status: EU Directives are being published on this site to aid cross referencing from UK legislation. After IP completion day (31 December 2020 11pm) no further amendments will be applied to this version.*

---

- 16. Technically permissible maximum masses
    - 16.1. Technically permissible maximum laden mass: ... kg
    - 16.2. Technically permissible mass on each axle:
      - 1. ... kg
      - 2. ... kg
      - 3. ... kg etc.
    - 16.3. Technically permissible mass on each axle group:
      - 1. ... kg
      - 2. ... kg
      - 3. ... kg etc.
    - 16.4. Technically permissible maximum mass of the combination: ... kg
  - 17. Intended registration/in service maximum permissible masses in national/international traffic <sup>(1)</sup>(<sup>o</sup>)
    - 17.1. Intended registration/in service maximum permissible laden mass: ... kg
    - 17.2. Intended registration/in service maximum permissible laden mass on each axle:
      - 1. ... kg
      - 2. ... kg
      - 3. ... kg
    - 17.3. Intended registration/in service maximum permissible laden mass on each axle group:
      - 1. ... kg
      - 2. ... kg
      - 3. ... kg
    - 17.4. Intended registration/in service maximum permissible mass of the combination: ... kg
  - 18. Technically permissible maximum towable mass in case of:
    - 18.1. Drawbar trailer: ... kg
    - 18.2. Semi-trailer: ... kg
    - 18.3. Centre-axle trailer: ... kg
    - 18.4. Unbraked trailer: ... kg
  - 19. Technically permissible maximum static mass at the coupling point: ... kg
- Power plant**
- 20. Manufacturer of the engine: ...
  - 21. Engine code as marked on the engine: ...



- 22. Working principle: ...
- 23. Pure electric: yes/no <sup>(1)</sup>
- 23.1. Hybrid [electric] vehicle: yes/no <sup>(1)</sup>
- 24. Number and arrangement of cylinders: ...
- 25. Engine capacity: ... cm<sup>3</sup>
- [<sup>F6</sup>26. Fuel: Diesel/petrol/LPG/CNG-Biomethane/LNG/Ethanol/Biodiesel/Hydrogen <sup>(1)</sup>
- 26.1. Mono fuel/Bi fuel/Flex fuel/Dual-fuel <sup>(1)</sup>]
- 26.2. [<sup>F7</sup>(Dual-fuel only) Type 1A/Type 1B/Type 2A/Type 2B/Type 3B <sup>(1)</sup>]
- [<sup>F23</sup>27. Maximum power
- 27.1. Maximum net power (<sup>g</sup>): ... kW at ... min<sup>-1</sup> (internal combustion engine) <sup>(1)</sup>
- 27.2. Maximum hourly output: ... kW (electric motor) <sup>(1)</sup>
- 27.3. Maximum net power: ... kW (electric motor) <sup>(1)</sup>
- 27.4. Maximum 30 minutes power: ... kW (electric motor) <sup>(1)</sup>]
- 28. Gearbox (type): ...

**Maximum speed**

- 29. Maximum speed: ... km/h

**Axles and suspension**

- [<sup>F16</sup>31. Position of lift axle(s): ...]
- 32. Position of loadable axle(s): ...
- 33. Drive axle(s) fitted with air suspension or equivalent: yes/no <sup>(1)</sup>
- 35. Tyre/wheel combination (<sup>h</sup>): ...

**Brakes**

- 36. Trailer brake connections mechanical/electric/pneumatic/hydraulic <sup>(1)</sup>
- 37. Pressure in feed line for trailer braking system: ... bar

**Bodywork**

- 38. Code for bodywork (<sup>i</sup>): ...
- 41. Number and configuration of doors: ...
- 42. Number of seating positions (including the driver) (<sup>k</sup>): ...

**Coupling device**

- 44. Approval number or approval mark of coupling device (if fitted): ...
- 45.1. Characteristics values <sup>(1)</sup>: D: .../ V: .../ S: .../ U: ...

**Environmental performances**

---

*Status: EU Directives are being published on this site to aid cross referencing from UK legislation. After IP completion day (31 December 2020 11pm) no further amendments will be applied to this version.*

---

46. Sound level

Stationary: ... dB(A) at engine speed: ... min<sup>-1</sup>

Drive-by: ... dB(A)

47. Exhaust emission level (<sup>1</sup>): Euro ...

[<sup>F6</sup>48. Exhaust emissions (<sup>m</sup>)(<sup>m1</sup>)(<sup>m2</sup>):

Number of the base regulatory act and latest amending regulatory act applicable: ...

1.1. test procedure: ESC

CO: ... HC: ... NO<sub>x</sub>: ... HC + NO<sub>x</sub>: ... Particulates: ...

Smoke opacity (ELR): ... (m<sup>-1</sup>)

1.2. test procedure: WHSC (EURO VI)

CO: ... THC: ... NMHC: ... NO<sub>x</sub>: ... THC + NO<sub>x</sub>: ... NH<sub>3</sub>: ... Particulates (mass): ... Particles (number): ...

2.1. test procedure: ETC (if applicable)

CO: ... NO<sub>x</sub>: ... NMHC: ... THC: ... CH<sub>4</sub>: ... Particulates: ...

2.2. test procedure: WHTC (EURO VI)

CO: ... NO<sub>x</sub>: ... NMHC: ... THC: ... CH<sub>4</sub>: ... NH<sub>3</sub>: ... Particulates (mass): ... Particles (number): ...]

48.1. Smoke corrected absorption coefficient: ... (m<sup>-1</sup>)

**Miscellaneous**

50. Type-approved according to the design requirements for transporting dangerous goods: yes/class(es): .../no (<sup>1</sup>):

51. For special purpose vehicles: designation in accordance with Annex II Section 5: ...

52. Remarks (<sup>n</sup>): ...

**SIDE 2 VEHICLE CATEGORIES O<sub>1</sub> AND O<sub>2</sub>(complete and completed vehicles)**

**Side 2**

**General construction characteristics**

1. Number of axles: ... and wheels: ...

1.1. Number and position of axles with twin wheels: ...

**Main dimensions**

4. Wheelbase (<sup>e</sup>): ... mm

4.1. Axle spacing:

1-2: ... mm

2-3: ... mm

3-4: ... mm

5. Length: ... mm
6. Width: ... mm
7. Height: ... mm
10. Distance between the centre of the coupling device and the rear end of the vehicle: ... mm
11. Length of the loading area: ... mm
12. Rear overhang: ... mm

### **Masses**

- [<sup>F3</sup>13. Mass in running order: ... kg]
- 13.1. Distribution of this mass amongst the axles:
  1. ... kg
  2. ... kg
  3. ... kg
- 13.2. [<sup>F4</sup>Actual mass of the vehicle: ... kg]
16. Technically permissible maximum masses
  - 16.1. Technically permissible maximum laden mass: ... kg
  - 16.2. Technically permissible mass on each axle:
    1. ... kg
    2. ... kg
    3. ... kg etc.
  - 16.3. Technically permissible mass on each axle group:
    1. ... kg
    2. ... kg
    3. ... kg etc.
19. Technically permissible maximum static mass on the coupling point of a semi-trailer or centre-axle trailer: ... kg

### **Maximum speed**

29. Maximum speed: ... km/h

### **Axles and suspension**

- 30.1. Track of each steered axle: ... mm
- 30.2. Track of all other axles: ... mm
- [<sup>F16</sup>31. Position of lift axle(s): ...]
32. Position of loadable axle(s): ...

---

*Status: EU Directives are being published on this site to aid cross referencing from UK legislation. After IP completion day (31 December 2020 11pm) no further amendments will be applied to this version.*

---

34. Axle(s) fitted with air suspension or equivalent: yes/no <sup>(1)</sup>

35. Tyre/wheel combination <sup>(h)</sup>: ...

#### **Brakes**

36. Trailer brake connections mechanical/electric/pneumatic/hydraulic <sup>(1)</sup>

#### **Bodywork**

38. Code for bodywork <sup>(i)</sup>: ...

#### **Coupling device**

44. Approval number or approval mark of coupling device (if fitted): ...

45.1. Characteristics values <sup>(1)</sup>: D: .../ V: .../ S: .../ U: ...

#### **Miscellaneous**

50. Type-approved according to the design requirements for transporting dangerous goods: yes/class(es): .../no <sup>(1)</sup>:

51. For special purpose vehicles: designation in accordance with Annex II Section 5: ...

52. Remarks <sup>(n)</sup>: ...

### **SIDE 2 VEHICLE CATEGORIES O<sub>3</sub> AND O<sub>4</sub>(complete and completed vehicles)**

#### **Side 2**

#### **General construction characteristics**

1. Number of axles: ... and wheels: ...

1.1. Number and position of axles with twin wheels: ...

2. Steered axles (number, position): ...

#### **Main dimensions**

4. Wheelbase <sup>(c)</sup>: ... mm

4.1. Axle spacing:

1-2: ... mm

2-3: ... mm

3-4: ... mm

5. Length: ... mm

6. Width: ... mm

7. Height: ... mm

10. Distance between the centre of the coupling device and the rear end of the vehicle: ... mm

11. Length of the loading area: ... mm

12. Rear overhang: ... mm

#### **Masses**

[<sup>F3</sup>13. Mass in running order: ... kg]

- 13.1. Distribution of this mass amongst the axles:
1. ... kg
  2. ... kg
  3. ... kg
16. Technically permissible maximum masses
- 16.1. Technically permissible maximum laden mass: ... kg
- 16.2. Technically permissible mass on each axle:
1. ... kg
  2. ... kg
  3. ... kg etc.
- 16.3. Technically permissible mass on each axle group:
1. ... kg
  2. ... kg
  3. ... kg etc.
17. Intended registration/in service maximum permissible masses in national/international traffic <sup>(1)</sup>(<sup>o</sup>)
- 17.1. Intended registration/in service maximum permissible laden mass: ... kg
- 17.2. Intended registration/in service maximum permissible laden mass on each axle:
1. ... kg
  2. ... kg
  3. ... kg
- 17.3. Intended registration/in service maximum permissible laden mass on each axle group:
1. ... kg
  2. ... kg
  3. ... kg
19. Technically permissible maximum static mass on the coupling point of a semi-trailer or centre-axle trailer: ... kg

**Maximum speed**

29. Maximum speed: ... km/h

**Axles and suspension**

- [<sup>F16</sup>31. Position of lift axle(s): ...]
32. Position of loadable axle(s): ...
34. Axle(s) fitted with air suspension or equivalent: yes/no (<sup>1</sup>)

---

*Status: EU Directives are being published on this site to aid cross referencing from UK legislation. After IP completion day (31 December 2020 11pm) no further amendments will be applied to this version.*

---

35. Tyre/wheel combination <sup>(h)</sup>: ...

**Brakes**

36. Trailer brake connections mechanical/electric/pneumatic/hydraulic <sup>(l)</sup>

**Bodywork**

38. Code for bodywork <sup>(i)</sup>: ...

**Coupling device**

44. Approval number or approval mark of coupling device (if fitted): ...

45.1. Characteristics values <sup>(l)</sup>: D: .../ V: .../ S: .../ U: ...<sup>å</sup>

**Miscellaneous**

50. Type-approved according to the design requirements for transporting dangerous goods: yes/class(es): .../no <sup>(l)</sup>:

51. For special purpose vehicles: designation in accordance with Annex II Section 5: ...

52. Remarks <sup>(n)</sup>: ...

*PART II*

**INCOMPLETE VEHICLES**

MODEL INCOMPLETE VEHICLES

C1 —

SIDE 1

EC CERTIFICATE OF CONFORMITY

**Side 1**

The undersigned [... (*Full name and position*)] hereby certifies that the vehicle:

0.1. Make (Trade name of manufacturer): ...

0.2. Type: ...

Variant <sup>(a)</sup>: ...

Version <sup>(a)</sup>: ...

0.2.1. Commercial name: ...

0.4. Vehicle category: ...

0.5. [<sup>F3</sup>Company name and address of manufacturer: ...]

0.6. Location and method of attachment of the statutory plates: ...

Location of the vehicle identification number: ...

0.9. Name and address of the manufacturer's representative (if any): ...

0.10. Vehicle identification number: ...

conforms in all respects to the type described in approval (... *type-approval number including extension number*) issued on (... *date of issue*) and

cannot be permanently registered without further approvals.

---

(Place) (Date): ...	(Signature): ...
---------------------	------------------

---

MODEL INCOMPLETE VEHICLES TYPE-APPROVED IN SMALL  
C2 — SERIES[Year][Sequential number]

SIDE 1

EC CERTIFICATE OF CONFORMITY

**Side 1**

The undersigned [... (*Full name and position*)] hereby certifies that the vehicle:

- 0.1. Make (Trade name of manufacturer): ...
- 0.2. Type: ...
  - Variant <sup>(a)</sup>: ...
  - Version <sup>(a)</sup>: ...
- 0.2.1. Commercial name: ...
- 0.4. Vehicle category: ...
- 0.5. [<sup>F3</sup>Company name and address of manufacturer: ...]
- 0.6. Location and method of attachment of the statutory plates: ...
  - Location of the vehicle identification number: ...
- 0.9. Name and address of the manufacturer's representative (if any): ...
- 0.10. Vehicle identification number: ...

conforms in all respects to the type described in approval (... *type-approval number including extension number*) issued on (... *date of issue*) and

cannot be permanently registered without further approvals.

---

(Place) (Date): ...	(Signature): ...
---------------------	------------------

---

SIDE 2 VEHICLE CATEGORY M<sub>1</sub>(incomplete vehicles)

**Side 2**

**General construction characteristics**

1. Number of axles: ... and wheels: ...
3. Powered axles (number, position, interconnection): ... ..

**Main dimensions**

4. Wheelbase <sup>(c)</sup>: ... mm
- 4.1. Axle spacing:

---

*Status: EU Directives are being published on this site to aid cross referencing from UK legislation. After IP completion day (31 December 2020 11pm) no further amendments will be applied to this version.*

---

1-2: ... mm

2-3: ... mm

3-4: ... mm

5.1. Maximum permissible length: ... mm

6.1. Maximum permissible width: ... mm

7.1. Maximum permissible height: ... mm

12.1. Maximum permissible rear overhang: ... mm

### **Masses**

[<sup>F4</sup>13.2. Actual mass of the vehicle: ... kg]

[<sup>F3</sup>14. Actual mass of the vehicle: ... kg]

14.1. Distribution of this mass amongst the axles:

1. ... kg

2. ... kg

3. ... kg

15. Minimum mass of the vehicle when completed: ... kg

15.1. Distribution of this mass amongst the axles:

1. ... kg

2. ... kg

3. ... kg

16. Technically permissible maximum masses

16.1. Technically permissible maximum laden mass: ... kg

16.2. Technically permissible mass on each axle:

1. ... kg

2. ... kg

3. ... kg etc.

16.4. Technically permissible maximum mass of the combination: ... kg

18. Technically permissible maximum towable mass in case of:

18.1. Drawbar trailer: ... kg

18.3. Centre-axle trailer: ... kg

18.4. Unbraked trailer: ... kg

19. Technically permissible maximum static vertical mass at the coupling point: ... kg

### **Power plant**

20. Manufacturer of the engine: ...



- 21. Engine code as marked on the engine: ...
- 22. Working principle: ...
- 23. Pure electric: yes/no <sup>(1)</sup>
- 23.1. Hybrid [electric] vehicle: yes/no <sup>(1)</sup>
- 24. Number and arrangement of cylinders: ...
- 25. Engine capacity: ... cm<sup>3</sup>
- [<sup>F6</sup>26. Fuel: Diesel/petrol/LPG/CNG-Biomethane/LNG/Ethanol/Biodiesel/Hydrogen <sup>(1)</sup>
- 26.1. Mono fuel/Bi fuel/Flex fuel/Dual-fuel <sup>(1)</sup>]
- 26.2. [<sup>F7</sup>(Dual-fuel only) Type 1A/Type 1B/Type 2A/Type 2B/Type 3B <sup>(1)</sup>]
- [<sup>F23</sup>27. Maximum power
- 27.1. Maximum net power (<sup>g</sup>): ... kW at ... min<sup>-1</sup> (internal combustion engine) <sup>(1)</sup>
- 27.2. Maximum hourly output: ... kW (electric motor) <sup>(1)</sup>
- 27.3. Maximum net power: ... kW (electric motor) <sup>(1)</sup>
- 27.4. Maximum 30 minutes power: ... kW (electric motor) <sup>(1)</sup>]

#### **Maximum speed**

- 29. Maximum speed: ... km/h

#### **Axles and suspension**

- 30. Axle(s) track:
  - 1. ... mm
  - 2. ... mm
  - 3. ... mm
- 35. Tyre/wheel combination (<sup>h</sup>): ...

#### **Brakes**

- 36. Trailer brake connections mechanical/electric/pneumatic/hydraulic <sup>(1)</sup>

#### **Bodywork**

- 41. Number and configuration of doors: ...
- 42. Number of seating positions (including the driver) (<sup>k</sup>): ...

#### **Environmental performances**

- 46. Sound level

Stationary: ... dB(A) at engine speed: ... min<sup>-1</sup>

Drive-by: ... dB(A)

*Status: EU Directives are being published on this site to aid cross referencing from UK legislation. After IP completion day (31 December 2020 11pm) no further amendments will be applied to this version.*

47. Exhaust emission level <sup>(1)</sup>: Euro ...

[<sup>F6</sup>48. Exhaust emissions <sup>(m)</sup>(<sup>m1</sup>)(<sup>m2</sup>):

Number of the base regulatory act and latest amending regulatory act applicable: ...

1.1. test procedure: Type I or ESC <sup>(1)</sup>

CO: ... HC: ... NO<sub>x</sub>: ... HC + NO<sub>x</sub>: ... Particulates: ...

Smoke opacity (ELR): ... (m<sup>-1</sup>)

1.2. test procedure: Type I (Euro 5 or 6 (1)) or WHSC (EURO VI) <sup>(1)</sup>

CO: ... THC: ... NMHC: ... NO<sub>x</sub>: ... THC + NO<sub>x</sub>: ... NH<sub>3</sub>: ... Particulates (mass): ... Particles (number): ...

2.1. test procedure: ETC (if applicable)

CO: ... NO<sub>x</sub>: ... NMHC: ... THC: ... CH<sub>4</sub>: ... Particulates: ...

2.2. test procedure: WHTC (EURO VI)

CO: ... NO<sub>x</sub>: ... NMHC: ... THC: ... CH<sub>4</sub>: ... NH<sub>3</sub>: ... Particulates (mass): ... Particles (number): ...]

48.1. Smoke corrected absorption coefficient: ... (m<sup>-1</sup>)

49. CO<sub>2</sub> emissions/fuel consumption/electric energy consumption <sup>(m)</sup>:

1. all power train except pure electric vehicles

	CO <sub>2</sub> emissions	Fuel consumption
<b>Urban conditions:</b>	... g/km	... l/100 km/m <sup>3</sup> /100 km <sup>(1)</sup>
<b>Extra-urban conditions:</b>	... g/km	... l/100 km/m <sup>3</sup> /100 km <sup>(1)</sup>
<b>Combined:</b>	... g/km	... l/100 km/m <sup>3</sup> /100 km <sup>(1)</sup>
<b>Weighted, combined</b>	... g/km	... l/100 km

2. pure electric vehicles and OVC hybrid electric vehicles

Electric energy consumption (weighted, combined <sup>(1)</sup>)  
Electric range ... Wh/km  
... km

**Miscellaneous**

52. Remarks <sup>(1)</sup>: ...

SIDE 2 VEHICLE CATEGORY M<sub>2</sub>(incomplete vehicles)

**Side 2**

**General construction characteristics**

1. Number of axles: ... and wheels: ...
- 1.1. Number and position of axles with twin wheels: ...
2. Steered axles (number, position): ...
3. Powered axles (number, position, interconnection): ... ..

**Main dimensions**

4. Wheelbase <sup>(c)</sup>: ... mm
- 4.1. Axle spacing:
  - 1-2: ... mm
  - 2-3: ... mm
  - 3-4: ... mm
- 5.1. Maximum permissible length: ... mm
- 6.1. Maximum permissible width: ... mm
- 7.1. Maximum permissible height: ... mm
- 12.1. Maximum permissible rear overhang: ... mm

**Masses**

- [<sup>F3</sup>14. Actual mass of the vehicle: ... kg]
- 14.1. Distribution of this mass amongst the axles:
  1. ... kg
  2. ... kg
  3. ... kg etc.
15. Minimum mass of the vehicle when completed: ... kg
- 15.1. Distribution of this mass amongst the axles:
  1. ... kg
  2. ... kg
  3. ... kg
16. Technically permissible maximum masses
- 16.1. Technically permissible maximum laden mass: ... kg
- 16.2. Technically permissible mass on each axle:
  1. ... kg
  2. ... kg

---

*Status: EU Directives are being published on this site to aid cross referencing from UK legislation. After IP completion day (31 December 2020 11pm) no further amendments will be applied to this version.*

---

- 3. ... kg etc.
- 16.3. Technically permissible mass on each axle group:
  - 1. ... kg
  - 2. ... kg
  - 3. ... kg etc.
- 16.4. Technically permissible maximum mass of the combination: ... kg
- 17. Intended registration/in service maximum permissible masses in national/international traffic <sup>(1)</sup>(<sup>0</sup>)
- 17.1. Intended registration/in service maximum permissible laden mass: ... kg
- 17.2. Intended registration/in service maximum permissible laden mass on each axle:
  - 1. ... kg
  - 2. ... kg
  - 3. ... kg
- 17.3. Intended registration/in service maximum permissible laden mass on each axle group:
  - 1. ... kg
  - 2. ... kg
  - 3. ... kg
- 17.4. Intended registration/in service maximum permissible mass of the combination: ... kg
- 18. Technically permissible maximum towable mass in case of:
  - 18.1. Drawbar trailer: ... kg
  - 18.3. Centre-axle trailer: ... kg
  - 18.4. Unbraked trailer: ... kg
- 19. Technically permissible maximum static mass at the coupling point: ... kg
- Power plant**
- 20. Manufacturer of the engine: ...
- 21. Engine code as marked on the engine: ...
- 22. Working principle: ...
- 23. Pure electric: yes/no <sup>(1)</sup>
- 23.1. Hybrid [electric] vehicle: yes/no <sup>(1)</sup>
- 24. Number and arrangement of cylinders: ...
- 25. Engine capacity: ... cm<sup>3</sup>
- [<sup>F6</sup>26. Fuel: Diesel/petrol/LPG/CNG-Biomethane/LNG/Ethanol/Biodiesel/Hydrogen <sup>(1)</sup>

- 26.1. Mono fuel/Bi fuel/Flex fuel/Dual-fuel <sup>(1)</sup>]
- 26.2. [<sup>F7</sup>(Dual-fuel only) Type 1A/Type 1B/Type 2A/Type 2B/Type 3B <sup>(1)</sup>]
- [<sup>F23</sup>27. Maximum power
- 27.1. Maximum net power (<sup>g</sup>): ... kW at ... min<sup>-1</sup> (internal combustion engine) <sup>(1)</sup>
- 27.2. Maximum hourly output: ... kW (electric motor) <sup>(1)</sup>
- 27.3. Maximum net power: ... kW (electric motor) <sup>(1)</sup>
- 27.4. Maximum 30 minutes power: ... kW (electric motor) <sup>(1)</sup>]
28. Gearbox (type): ...

**Maximum speed**

29. Maximum speed: ... km/h

**Axles and suspension**

30. Axle(s) track:
1. ... mm
  2. ... mm
  3. ... mm
33. Drive axle(s) fitted with air suspension or equivalent: yes/no <sup>(1)</sup>
35. Tyre/wheel combination <sup>(h)</sup>: ...

**Brakes**

36. Trailer brake connections mechanical/electric/pneumatic/hydraulic <sup>(1)</sup>
37. Pressure in feed line for trailer braking system: ... bar

**Coupling device**

44. Approval number or approval mark of coupling device (if fitted): ...
45. Type or classes of coupling devices which can be fitted: ...
- 45.1. Characteristics values <sup>(1)</sup>: D: .../ V: .../ S: .../ U: ...

**Environmental performances**

46. Sound level

Stationary: ... dB(A) at engine speed: ... min<sup>-1</sup>

Drive-by: ... dB(A)

47. Exhaust emission level <sup>(1)</sup>: Euro ...

[<sup>F6</sup>48. Exhaust emissions <sup>(m)</sup><sup>(m1)</sup><sup>(m2)</sup>:

Number of the base regulatory act and latest amending regulatory act applicable: ...

- 1.1. test procedure: Type I or ESC <sup>(1)</sup>

---

*Status: EU Directives are being published on this site to aid cross referencing from UK legislation. After IP completion day (31 December 2020 11pm) no further amendments will be applied to this version.*

---

CO: ... HC: ... NO<sub>x</sub>: ... HC + NO<sub>x</sub>: ... Particulates: ...

Smoke opacity (ELR): ... (m<sup>-1</sup>)

1.2. test procedure: Type I (Euro 5 or 6 (1)) or WHSC (EURO VI) <sup>(1)</sup>

CO: ... THC: ... NMHC: ... NO<sub>x</sub>: ... THC + NO<sub>x</sub>: ... NH<sub>3</sub>: ... Particulates (mass): ... Particles (number): ...

2.1. test procedure: ETC (if applicable)

CO: ... NO<sub>x</sub>: ... NMHC: ... THC: ... CH<sub>4</sub>: ... Particulates: ...

2.2. test procedure: WHTC (EURO VI)

CO: ... NO<sub>x</sub>: ... NMHC: ... THC: ... CH<sub>4</sub>: ... NH<sub>3</sub>: ... Particulates (mass): ... Particles (number): ...]

48.1. Smoke corrected absorption coefficient: ... (m<sup>-1</sup>)

#### **Miscellaneous**

52. Remarks <sup>(n)</sup>: ...

SIDE 2 VEHICLE CATEGORY M<sub>3</sub>(incomplete vehicles)

#### **Side 2**

#### **General construction characteristics**

1. Number of axles: ... and wheels: ...

1.1. Number and position of axles with twin wheels: ...

2. Steered axles (number, position): ...

3. Powered axles (number, position, interconnection): ... ..

#### **Main dimensions**

4. Wheelbase <sup>(e)</sup>: ... mm

4.1. Axle spacing:

1-2: ... mm

2-3: ... mm

3-4: ... mm

5.1. Maximum permissible length: ... mm

6.1. Maximum permissible width: ... mm

7.1. Maximum permissible height: ... mm

12.1. Maximum permissible rear overhang: ... mm

#### **Masses**

[<sup>F3</sup>14. Actual mass of the vehicle: ... kg]

14.1. Distribution of this mass amongst the axles:

1. ... kg

---

*Status: EU Directives are being published on this site to aid cross referencing from UK legislation. After IP completion day (31 December 2020 11pm) no further amendments will be applied to this version.*

---

2. ... kg
3. ... kg etc.
15. Minimum mass of the vehicle when completed: ... kg
- 15.1. Distribution of this mass amongst the axles:
  1. ... kg
  2. ... kg
  3. ... kg
16. Technically permissible maximum masses
- 16.1. Technically permissible maximum laden mass: ... kg
- 16.2. Technically permissible mass on each axle:
  1. ... kg
  2. ... kg
  3. ... kg etc.
- 16.3. Technically permissible mass on each axle group:
  1. ... kg
  2. ... kg
  3. ... kg etc.
- 16.4. Technically permissible maximum mass of the combination: ... kg
17. Intended registration/in service maximum permissible masses in national/international traffic <sup>(1)</sup>(<sup>o</sup>)
- 17.1. Intended registration/in service maximum permissible laden mass: ... kg
- 17.2. Intended registration/in service maximum permissible laden mass on each axle:
  1. ... kg
  2. ... kg
  3. ... kg
- 17.3. Intended registration/in service maximum permissible laden mass on each axle group:
  1. ... kg
  2. ... kg
  3. ... kg
- 17.4. Intended registration/in service maximum permissible mass of the combination: ... kg
18. Technically permissible maximum towable mass in case of:
  - 18.1. Drawbar trailer: ... kg

---

*Status: EU Directives are being published on this site to aid cross referencing from UK legislation. After IP completion day (31 December 2020 11pm) no further amendments will be applied to this version.*

---

18.3. Centre-axle trailer: ... kg

18.4. Unbraked trailer: ... kg

19. Technically permissible maximum static mass at the coupling point: ... kg

**Power plant**

20. Manufacturer of the engine: ...

21. Engine code as marked on the engine: ...

22. Working principle: ...

23. Pure electric: yes/no <sup>(1)</sup>

23.1. Hybrid [electric] vehicle: yes/no <sup>(1)</sup>

24. Number and arrangement of cylinders: ...

25. Engine capacity: ... cm<sup>3</sup>

[<sup>F6</sup>26. Fuel: Diesel/petrol/LPG/CNG-Biomethane/LNG/Ethanol/Biodiesel/Hydrogen <sup>(1)</sup>

26.1. Mono fuel/Bi fuel/Flex fuel/Dual-fuel <sup>(1)</sup>]

26.2. [<sup>F7</sup>(Dual-fuel only) Type 1A/Type 1B/Type 2A/Type 2B/Type 3B <sup>(1)</sup>]

[<sup>F23</sup>27. Maximum power

27.1. Maximum net power (<sup>g</sup>): ... kW at ... min<sup>-1</sup> (internal combustion engine) <sup>(1)</sup>

27.2. Maximum hourly output: ... kW (electric motor) <sup>(1)</sup>

27.3. Maximum net power: ... kW (electric motor) <sup>(1)</sup>

27.4. Maximum 30 minutes power: ... kW (electric motor) <sup>(1)</sup>]

28. Gearbox (type): ...

**Maximum speed**

29. Maximum speed: ... km/h

**Axles and suspension**

30.1. Track of each steered axle: ... mm

30.2. Track of all other axles: ... mm

32. Position of loadable axle(s): ...

33. Drive axle(s) fitted with air suspension or equivalent: yes/no <sup>(1)</sup>

35. Tyre/wheel combination (<sup>h</sup>): ...

**Brakes**

36. Trailer brake connections mechanical/electric/pneumatic/hydraulic <sup>(1)</sup>

37. Pressure in feed line for trailer braking system: ... bar

**Coupling device**



44. Approval number or approval mark of coupling device (if fitted): ...

45. Types or classes of coupling devices which can be fitted: ...

45.1. Characteristics values <sup>(1)</sup>: D: .../ V: .../ S: .../ U: ...

### **Environmental performances**

46. Sound level

Stationary: ... dB(A) at engine speed: ... min<sup>-1</sup>

Drive-by: ... dB(A)

47. Exhaust emission level <sup>(1)</sup>: Euro ...

[<sup>F</sup>48. Exhaust emissions <sup>(m)</sup>(<sup>m1</sup>)(<sup>m2</sup>):

Number of the base regulatory act and latest amending regulatory act applicable: ...

1.1. test procedure: ESC

CO: ... HC: ... NO<sub>x</sub>: ... HC + NO<sub>x</sub>: ... Particulates: ...

Smoke opacity (ELR): ... (m<sup>-1</sup>)

1.2. test procedure: WHSC (EURO VI)

CO: ... THC: ... NMHC: ... NO<sub>x</sub>: ... THC + NO<sub>x</sub>: ... NH<sub>3</sub>: ... Particulates (mass): ... Particles (number): ...

2.1. test procedure: ETC (if applicable)

CO: ... NO<sub>x</sub>: ... NMHC: ... THC: ... CH<sub>4</sub>: ... Particulates: ...

2.2. test procedure: WHTC (EURO VI)

CO: ... NO<sub>x</sub>: ... NMHC: ... THC: ... CH<sub>4</sub>: ... NH<sub>3</sub>: ... Particulates (mass): ... Particles (number): ...]

48.1. Smoke corrected absorption coefficient: ... (m<sup>-1</sup>)

### **Miscellaneous**

52. Remarks <sup>(n)</sup>: ...

SIDE 2 VEHICLE CATEGORY N<sub>1</sub>(incomplete vehicles)

### **Side 2**

#### **General construction characteristics**

1. Number of axles: ... and wheels: ...

1.1. Number and position of axles with twin wheels: ...

3. Powered axles (number, position, interconnection): ... ..

#### **Main dimensions**

4. Wheelbase <sup>(c)</sup>: ... mm

4.1. Axle spacing:

---

*Status: EU Directives are being published on this site to aid cross referencing from UK legislation. After IP completion day (31 December 2020 11pm) no further amendments will be applied to this version.*

---

1-2: ... mm

2-3: ... mm

3-4: ... mm

- 5.1. Maximum permissible length: ... mm
- 6.1. Maximum permissible width: ... mm
- 7.1. Maximum permissible height: ... mm
- 8. Fifth wheel lead for semi-trailer towing vehicle (maximum and minimum): ... mm
- 12.1. Maximum permissible rear overhang: ... mm

#### **Masses**

- [<sup>F4</sup>13. Mass in running order: ... kg]
- [<sup>F3</sup>14. Actual mass of the vehicle: ... kg]
- 14.1. Distribution of this mass amongst the axles:
  - 1. ... kg
  - 2. ... kg
  - 3. ... kg etc.
- 15. Minimum mass of the vehicle when completed: ... kg
- 15.1. Distribution of this mass amongst the axles:
  - 1. ... kg
  - 2. ... kg
  - 3. ... kg
- 16. Technically permissible maximum masses
- 16.1. Technically permissible maximum laden mass: ... kg
- 16.2. Technically permissible mass on each axle:
  - 1. ... kg
  - 2. ... kg
  - 3. ... kg etc.
- 16.4. Technically permissible maximum mass of the combination: ... kg
- 18. Technically permissible maximum towable mass in case of:
  - 18.1. Drawbar trailer: ... kg
  - 18.2. Semi-trailer: ... kg
  - 18.3. Centre-axle trailer: ... kg
  - 18.4. Unbraked trailer: ... kg
- 19. Technically permissible maximum static mass at the coupling point: ... kg

**Power plant**

20. Manufacturer of the engine: ...
21. Engine code as marked on the engine: ...
22. Working principle: ...
23. Pure electric: yes/no <sup>(1)</sup>
- 23.1. Hybrid [electric] vehicle: yes/no <sup>(1)</sup>
24. Number and arrangement of cylinders: ...
25. Engine capacity: ... cm<sup>3</sup>
- [<sup>F6</sup>26. Fuel: Diesel/petrol/LPG/CNG-Biomethane/LNG/Ethanol/Biodiesel/Hydrogen <sup>(1)</sup>
- 26.1. Mono fuel/Bi fuel/Flex fuel/Dual-fuel <sup>(1)</sup>]
- 26.2. [<sup>F7</sup>(Dual-fuel only) Type 1A/Type 1B/Type 2A/Type 2B/Type 3B <sup>(1)</sup>]
- [<sup>F23</sup>27. Maximum power
- 27.1. Maximum net power (<sup>g</sup>): ... kW at ... min<sup>-1</sup> (internal combustion engine) <sup>(1)</sup>
- 27.2. Maximum hourly output: ... kW (electric motor) <sup>(1)</sup>
- 27.3. Maximum net power: ... kW (electric motor) <sup>(1)</sup>
- 27.4. Maximum 30 minutes power: ... kW (electric motor) <sup>(1)</sup>]
28. Gearbox (type): ...

**Maximum speed**

29. Maximum speed: ... km/h

**Axles and suspension**

30. Axle(s) track:
1. ... mm
2. ... mm
3. ... mm
35. Tyre/wheel combination (<sup>h</sup>): ...

**Brakes**

36. Trailer brake connections mechanical/electric/pneumatic/hydraulic <sup>(1)</sup>
37. Pressure in feed line for trailer braking system: ... bar

**Coupling device**

44. Approval number or approval mark of coupling device (if fitted): ...
45. Types or classes of coupling devices which can be fitted: ...
- 45.1. Characteristics values <sup>(1)</sup>: D: .../ V: .../ S: .../ U: ...

*Status: EU Directives are being published on this site to aid cross referencing from UK legislation. After IP completion day (31 December 2020 11pm) no further amendments will be applied to this version.*

## Environmental performances

46. Sound level

Stationary: ... dB(A) at engine speed: ... min<sup>-1</sup>

Drive-by: ... dB(A)

47. Exhaust emission level (<sup>1</sup>): Euro ...

[<sup>F6</sup>48. Exhaust emissions (<sup>m</sup>)(<sup>m1</sup>)(<sup>m2</sup>):

Number of the base regulatory act and latest amending regulatory act applicable: ...

1.1. test procedure: Type I or ESC (<sup>1</sup>)

CO: ... HC: ... NO<sub>x</sub>: ... HC + NO<sub>x</sub>: ... Particulates: ...

Smoke opacity (ELR): ... (m<sup>-1</sup>)

1.2. test procedure: Type I (Euro 5 or 6 (<sup>1</sup>)) or WHSC (EURO VI) (<sup>1</sup>)

CO: ... THC: ... NMHC: ... NO<sub>x</sub>: ... THC + NO<sub>x</sub>: ... NH<sub>3</sub>: ... Particulates (mass): ... Particles (number): ...

2.1. test procedure: ETC (if applicable)

CO: ... NO<sub>x</sub>: ... NMHC: ... THC: ... CH<sub>4</sub>: ... Particulates:

2.2. test procedure: WHTC (EURO VI)

CO: ... NO<sub>x</sub>: ... NMHC: ... THC: ... CH<sub>4</sub>: ... NH<sub>3</sub>: ... Particulates (mass): ... Particles (number):]

48.1. Smoke corrected absorption coefficient: ... (m<sup>-1</sup>)

49. CO<sub>2</sub> emissions/fuel consumption/electric energy consumption (<sup>m</sup>):

1. all power train except pure electric vehicles

	CO <sub>2</sub> emissions	Fuel consumption
<b>Urban conditions:</b>	... g/km	... l/100 km/m <sup>3</sup> /100 km ( <sup>1</sup> )
<b>Extra-urban conditions:</b>	... g/km	... l/100 km/m <sup>3</sup> /100 km ( <sup>1</sup> )
<b>Combined:</b>	... g/km	... l/100 km/m <sup>3</sup> /100 km ( <sup>1</sup> )
<b>Weighted, combined</b>	... g/km	... l/100 km

2. pure electric vehicles and OVC hybrid electric vehicles

Electric ... Wh/km  
energy  
consumption

(weighted,  
combined  
(<sup>1</sup>))  
Electric ... km  
range

3. [<sup>F38</sup>Vehicle fitted with eco-innovation(s): yes/no (<sup>1</sup>)
  - 3.1. General code of the eco-innovation(s) (<sup>P1</sup>): ...
  - 3.2. Total CO<sub>2</sub> emissions saving due to the eco-innovation(s) (<sup>P2</sup>) (repeat for each reference fuel tested): ...]

### Miscellaneous

52. Remarks (<sup>n</sup>): ...

SIDE 2 VEHICLE CATEGORY N<sub>2</sub>(incomplete vehicles)

### Side 2

#### General construction characteristics

1. Number of axles: ... and wheels: ...
  - 1.1. Number and position of axles with twin wheels: ...
2. Steered axles (number, position): ...
3. Powered axles (number, position, interconnection): ... ..

#### Main dimensions

4. Wheelbase (<sup>c</sup>): ... mm
  - 4.1. Axle spacing:
    - 1-2: ... mm
    - 2-3: ... mm
    - 3-4: ... mm
  - 5.1. Maximum permissible length: ... mm
  - 6.1. Maximum permissible width: ... mm
  8. Fifth wheel lead for semi-trailer towing vehicle (maximum and minimum): ... mm
  - 12.1. Maximum permissible rear overhang: ... mm

#### Masses

- [<sup>F3</sup>14. Actual mass of the vehicle: ... kg]
  - 14.1. Distribution of this mass amongst the axles:
    1. ... kg
    2. ... kg
    3. ... kg etc.
  15. Minimum mass of the vehicle when completed: ... kg
    - 15.1. Distribution of this mass amongst the axles:

---

*Status: EU Directives are being published on this site to aid cross referencing from UK legislation. After IP completion day (31 December 2020 11pm) no further amendments will be applied to this version.*

---

1. ... kg
  2. ... kg
  3. ... kg
16. Technically permissible maximum masses
- 16.1. Technically permissible maximum laden mass: ... kg
- 16.2. Technically permissible mass on each axle:
1. ... kg
  2. ... kg
  3. ... kg etc.
- 16.3. Technically permissible mass on each axle group:
1. ... kg
  2. ... kg
  3. ... kg etc.
- 16.4. Technically permissible maximum mass of the combination: ... kg
17. Intended registration/in service maximum permissible masses in national/international traffic (<sup>1</sup>) (°)
- 17.1. Intended registration/in service maximum permissible laden mass: ... kg
- 17.2. Intended registration/in service maximum permissible laden mass on each axle:
1. ... kg
  2. ... kg
  3. ... kg
- 17.3. Intended registration/in service maximum permissible laden mass on each axle group:
1. ... kg
  2. ... kg
  3. ... kg
- 17.4. Intended registration/in service maximum permissible mass of the combination: ... kg
18. Technically permissible maximum towable mass in case of:
- 18.1. Drawbar trailer: ... kg
- 18.2. Semi-trailer: ... kg
- 18.3. Centre-axle trailer: ... kg
- 18.4. Unbraked trailer: ... kg
19. Technically permissible maximum static mass at the coupling point: ... kg

**Power plant**

- 20. Manufacturer of the engine: ...
- 21. Engine code as marked on the engine: ...
- 22. Working principle: ...
- 23. Pure electric: yes/no <sup>(1)</sup>
- 23.1. Hybrid [electric] vehicle: yes/no <sup>(1)</sup>
- 24. Number and arrangement of cylinders: ...
- 25. Engine capacity: ... cm<sup>3</sup>
- [<sup>F6</sup>26. Fuel: Diesel/petrol/LPG/CNG-Biomethane/LNG/Ethanol/Biodiesel/Hydrogen <sup>(1)</sup>
- 26.1. Mono fuel/Bi fuel/Flex fuel/Dual-fuel <sup>(1)</sup>]
- 26.2. [<sup>F7</sup>(Dual-fuel only) Type 1A/Type 1B/Type 2A/Type 2B/Type 3B <sup>(1)</sup>]
- [<sup>F23</sup>27. Maximum power
- 27.1. Maximum net power (<sup>g</sup>): ... kW at ... min<sup>-1</sup> (internal combustion engine) <sup>(1)</sup>
- 27.2. Maximum hourly output: ... kW (electric motor) <sup>(1)</sup>
- 27.3. Maximum net power: ... kW (electric motor) <sup>(1)</sup>
- 27.4. Maximum 30 minutes power: ... kW (electric motor) <sup>(1)</sup>]
- 28. Gearbox (type): ...

**Maximum speed**

- 29. Maximum speed: ... km/h

**Axles and suspension**

- [<sup>F16</sup>31. Position of lift axle(s): ...]
- 32. Position of loadable axle(s): ...
- 33. Drive axle(s) fitted with air suspension or equivalent: yes/no <sup>(1)</sup>
- 35. Tyre/wheel combination (<sup>h</sup>): ...

**Brakes**

- 36. Trailer brake connections mechanical/electric/pneumatic/hydraulic <sup>(1)</sup>
- 37. Pressure in feed line for trailer braking system: ... bar

**Coupling device**

- 44. Approval number or approval mark of coupling device (if fitted): ...
- 45. Types or classes of coupling devices which can be fitted: ...
- 45.1. Characteristics values <sup>(1)</sup>: D: .../ V: .../ S: .../ U: ...

**Environmental performances**

---

*Status: EU Directives are being published on this site to aid cross referencing from UK legislation. After IP completion day (31 December 2020 11pm) no further amendments will be applied to this version.*

---

46. Sound level

Stationary: ... dB(A) at engine speed: ... min<sup>-1</sup>

Drive-by: ... dB(A)

47. Exhaust emission level <sup>(1)</sup>: Euro ...

[<sup>F6</sup>48. Exhaust emissions <sup>(m)</sup><sup>(m1)</sup><sup>(m2)</sup>:

Number of the base regulatory act and latest amending regulatory act applicable: ...

1.1. test procedure: Type I or ESC <sup>(1)</sup>

CO: ... HC: ... NO<sub>x</sub>: ... HC + NO<sub>x</sub>: ... Particulates: ...

Smoke opacity (ELR): ... (m<sup>-1</sup>)

1.2. test procedure: Type I (Euro 5 or 6 (1)) or WHSC (EURO VI) <sup>(1)</sup>

CO: ... THC: ... NMHC: ... NO<sub>x</sub>: ... THC + NO<sub>x</sub>: ... NH<sub>3</sub>: ... Particulates (mass): ... Particles (number): ...

2.1. test procedure: ETC (if applicable)

CO: ... NO<sub>x</sub>: ... NMHC: ... THC: ... CH<sub>4</sub>: ... Particulates:

2.2. test procedure: WHTC (EURO VI)

CO: ... NO<sub>x</sub>: ... NMHC: ... THC: ... CH<sub>4</sub>: ... NH<sub>3</sub>: ... Particulates (mass): ... Particles (number): ...]

48.1. Smoke corrected absorption coefficient: ... (m<sup>-1</sup>)

**Miscellaneous**

52. Remarks <sup>(n)</sup>: ...

SIDE 2 VEHICLE CATEGORY N<sub>3</sub>(incomplete vehicles)

**Side 2**

**General construction characteristics**

1. Number of axles: ... and wheels: ...

1.1. Number and position of axles with twin wheels: ...

2. Steered axles (number, position): ...

3. Powered axles (number, position, interconnection): ... ..

**Main dimensions**

4. Wheelbase <sup>(c)</sup>: ... mm

4.1. Axle spacing:

1-2: ... mm

2-3: ... mm

3-4: ... mm



- 5.1. Maximum permissible length: ... mm
- 6.1. Maximum permissible width: ... mm
- 8. Fifth wheel lead for semi-trailer towing vehicle (maximum and minimum): ... mm
- 12.1. Maximum permissible rear overhang: ... mm

**Masses**

- [<sup>F3</sup>14. Actual mass of the vehicle: ... kg]
- 14.1. Distribution of this mass amongst the axles:
  - 1. ... kg
  - 2. ... kg
  - 3. ... kg etc.
- 15. Minimum mass of the vehicle when completed: ... kg
- 15.1. Distribution of this mass amongst the axles:
  - 1. ... kg
  - 2. ... kg
  - 3. ... kg
- 16. Technically permissible maximum masses
- 16.1. Technically permissible maximum laden mass: ... kg
- 16.2. Technically permissible mass on each axle:
  - 1. ... kg
  - 2. ... kg
  - 3. ... kg etc.
- 16.3. Technically permissible mass on each axle group:
  - 1. ... kg
  - 2. ... kg
  - 3. ... kg etc.
- 16.4. Technically permissible maximum mass of the combination: ... kg
- 17. Intended registration/in service maximum permissible masses in national/international traffic (<sup>1</sup>) (<sup>o</sup>)
- 17.1. Intended registration/in service maximum permissible laden mass: ... kg
- 17.2. Intended registration/in service maximum permissible laden mass on each axle:
  - 1. ... kg
  - 2. ... kg

---

*Status: EU Directives are being published on this site to aid cross referencing from UK legislation. After IP completion day (31 December 2020 11pm) no further amendments will be applied to this version.*

---

- 3. ... kg
- 17.3. Intended registration/in service maximum permissible laden mass on each axle group:
  - 1. ... kg
  - 2. ... kg
  - 3. ... kg
- 17.4. Intended registration/in service maximum permissible mass of the combination: ... kg
- 18. Technically permissible maximum towable mass in case of:
  - 18.1. Drawbar trailer: ... kg
  - 18.2. Semi-trailer: ... kg
  - 18.3. Centre-axle trailer: ... kg
  - 18.4. Unbraked trailer: ... kg
- 19. Technically permissible maximum static mass at the coupling point: ... kg

#### **Power plant**

- 20. Manufacturer of the engine: ...
- 21. Engine code as marked on the engine: ...
- 22. Working principle: ...
- 23. Pure electric: yes/no <sup>(1)</sup>
- 23.1. Hybrid [electric] vehicle: yes/no <sup>(1)</sup>
- 24. Number and arrangement of cylinders: ...
- 25. Engine capacity: ... cm<sup>3</sup>
- [<sup>F6</sup>26. Fuel: Diesel/petrol/LPG/CNG-Biomethane/LNG/Ethanol/Biodiesel/Hydrogen <sup>(1)</sup>
- 26.1. Mono fuel/Bi fuel/Flex fuel/Dual-fuel <sup>(1)</sup>]
- 26.2. [<sup>F7</sup>(Dual-fuel only) Type 1A/Type 1B/Type 2A/Type 2B/Type 3B <sup>(1)</sup>]
- [<sup>F23</sup>27. Maximum power
- 27.1. Maximum net power <sup>(8)</sup>: ... kW at ... min<sup>-1</sup> (internal combustion engine) <sup>(1)</sup>
- 27.2. Maximum hourly output: ... kW (electric motor) <sup>(1)</sup>
- 27.3. Maximum net power: ... kW (electric motor) <sup>(1)</sup>
- 27.4. Maximum 30 minutes power: ... kW (electric motor) <sup>(1)</sup>]
- 28. Gearbox (type): ...

#### **Maximum speed**

- 29. Maximum speed: ... km/h

**Axles and suspension**

- [<sup>F16</sup>31. Position of lift axle(s): ...]
32. Position of loadable axle(s): ...
33. Drive axle(s) fitted with air suspension or equivalent: yes/no (<sup>1</sup>)
35. Tyre/wheel combination (<sup>h</sup>): ...

**Brakes**

36. Trailer brake connections mechanical/electric/pneumatic/hydraulic (<sup>1</sup>)
37. Pressure in feed line for trailer braking system: ... bar

**Coupling device**

44. Approval number or approval mark of coupling device (if fitted): ...
45. Types or classes of coupling devices which can be fitted: ...
- 45.1. Characteristics values (<sup>1</sup>): D: .../ V: .../ S: .../ U: ...

**Environmental performances**

46. Sound level

Stationary: ... dB(A) at engine speed: ... min<sup>-1</sup>

Drive-by: ... dB(A)

47. Exhaust emission level (<sup>1</sup>): Euro ...

[<sup>F6</sup>48. Exhaust emissions (<sup>m</sup>)(<sup>m1</sup>)(<sup>m2</sup>):

Number of the base regulatory act and latest amending regulatory act applicable: ...

- 1.1. test procedure: ESC

CO: ... HC: ... NO<sub>x</sub>: ... HC + NO<sub>x</sub>: ... Particulates: ...

Smoke opacity (ELR): ... (m<sup>-1</sup>)

- 1.2. test procedure: WHSC (EURO VI)

CO: ... THC: ... NMHC: ... NO<sub>x</sub>: ... THC + NO<sub>x</sub>: ... NH<sub>3</sub>: ... Particulates (mass): ... Particles (number): ...

- 2.1. test procedure: ETC (if applicable)

CO: ... NO<sub>x</sub>: ... NMHC: ... THC: ... CH<sub>4</sub>: ... Particulates:

- 2.2. test procedure: WHTC (EURO VI)

CO: ... NO<sub>x</sub>: ... NMHC: ... THC: ... CH<sub>4</sub>: ... NH<sub>3</sub>: ... Particulates (mass): ... Particles (number): ...]

- 48.1. Smoke corrected absorption coefficient: ... (m<sup>-1</sup>)

**Miscellaneous**

52. Remarks (<sup>n</sup>): ...

---

*Status: EU Directives are being published on this site to aid cross referencing from UK legislation. After IP completion day (31 December 2020 11pm) no further amendments will be applied to this version.*

---

## SIDE 2 VEHICLE CATEGORIES O<sub>1</sub> AND O<sub>2</sub>(incomplete vehicles)

### Side 2

#### General construction characteristics

1. Number of axles: ... and wheels: ...
- 1.1. Number and position of axles with twin wheels: ...

#### Main dimensions

4. Wheelbase (°): ... mm
- 4.1. Axle spacing:
  - 1-2: ... mm
  - 2-3: ... mm
  - 3-4: ... mm
- 5.1. Maximum permissible length: ... mm
- 6.1. Maximum permissible width: ... mm
- 7.1. Maximum permissible height: ... mm
10. Distance between the centre of the coupling device and the rear end of the vehicle: ... mm
- 12.1. Maximum permissible rear overhang: ... mm

#### Masses

- [<sup>F3</sup>14. Actual mass of the vehicle: ... kg]
- 14.1. Distribution of this mass amongst the axles:
  1. ... kg
  2. ... kg
  3. ... kg
15. Minimum mass of the vehicle when completed: ... kg
- 15.1. Distribution of this mass amongst the axles:
  1. ... kg
  2. ... kg
  3. ... kg
16. Technically permissible maximum masses
- 16.1. Technically permissible maximum laden mass: ... kg
- 16.2. Technically permissible mass on each axle:
  1. ... kg
  2. ... kg
  3. ... kg etc.

16.3. Technically permissible mass on each axle group:

1. ... kg
2. ... kg
3. ... kg etc.

19.1. Technically permissible maximum static mass on the coupling point of a semi-trailer or centre-axle trailer: ... kg

#### **Maximum speed**

29. Maximum speed: ... km/h

#### **Axles and suspension**

30.1. Track of each steered axle: ... mm

30.2. Track of all other axles: ... mm

[<sup>F16</sup>31. Position of lift axle(s): ...]

32. Position of loadable axle(s): ...

34. Axle(s) fitted with air suspension or equivalent: yes/no (<sup>1</sup>)

35. Tyre/wheel combination (<sup>h</sup>): ...

#### **Coupling device**

44. Approval number or approval mark of coupling device (if fitted): ...

45. Types or classes of coupling devices which can be fitted: ...

45.1. Characteristics values (<sup>1</sup>): D: .../ V: .../ S: .../ U: ...

#### **Miscellaneous**

52. Remarks (<sup>n</sup>): ...

SIDE 2 VEHICLE CATEGORIES O<sub>3</sub> AND O<sub>4</sub>(incomplete vehicles)

#### **Side 2**

#### **General construction characteristics**

1. Number of axles: ... and wheels: ...

1.1. Number and position of axles with twin wheels: ...

2. Steered axle (number, position): ...

#### **Main dimensions**

4. Wheelbase (<sup>e</sup>): ... mm

4.1. Axle spacing:

1-2: ... mm

2-3: ... mm

3-4: ... mm

5.1. Maximum permissible length: ...mm

6.1. Maximum permissible width: ...mm

---

*Status: EU Directives are being published on this site to aid cross referencing from UK legislation. After IP completion day (31 December 2020 11pm) no further amendments will be applied to this version.*

---

- 7.1. Maximum permissible height: ...mm
- 10. Distance between the centre of the coupling device and the rear end of the vehicle: ...mm
- 12.1. Maximum permissible rear overhang: ...mm
- Masses**
- [<sup>F3</sup>14. Actual mass of the vehicle: ... kg]
- 14.1. Distribution of this mass amongst the axles:
  - 1. ... kg
  - 2. ... kg
  - 3. ... kg etc.
- 15. Minimum mass of the vehicle when completed: ... kg
- 15.1. Distribution of this mass amongst the axles:
  - 1. ... kg
  - 2. ... kg
  - 3. ... kg
- 16. Technically permissible maximum masses
- 16.1. Technically permissible maximum laden mass: ... kg
- 16.2. Technically permissible mass on each axle:
  - 1. ... kg
  - 2. ... kg
  - 3. ... kg etc.
- 16.3. Technically permissible mass on each axle group:
  - 1. ... kg
  - 2. ... kg
  - 3. ... kg etc.
- 17. Intended registration/in service maximum permissible masses in national/international traffic (<sup>1</sup>) (°)
- 17.1. Intended registration/in service maximum permissible laden mass: ... kg
- 17.2. Intended registration/in service maximum permissible laden mass on each axle:
  - 1. ... kg
  - 2. ... kg
  - 3. ... kg

17.3. Intended registration/in service maximum permissible laden mass on each axle group:

1. ... kg
2. ... kg
3. ... kg

19.1. Technically permissible maximum static mass on the coupling point of a semi-trailer or centre-axle trailer: ... kg

#### **Maximum speed**

29. Maximum speed: ... km/h

#### **Axles and suspension**

[<sup>F16</sup>31. Position of lift axle(s): ...]

32. Position of loadable axle(s): ...

34. Axle(s) fitted with air suspension or equivalent: yes/no (<sup>1</sup>)

35. Tyre/wheel combination (<sup>h</sup>): ...

#### **Coupling device**

44. Approval number or approval mark of coupling device (if fitted): ...

45. Types or classes of coupling devices which can be fitted: ...

45.1. Characteristics values (<sup>1</sup>): D: .../ V: .../ S: .../ U: ...

#### **Miscellaneous**

52. Remarks (<sup>n</sup>): ...

*Explanatory notes relating to Annex IX*

(<sup>1</sup>) Delete where not applicable

(<sup>a</sup>) Indicate the identification code. [<sup>F39</sup> This code shall contain not more than 25 characters for a variant and not more than 35 characters for a version.]

(<sup>b</sup>) Indicate whether the vehicle is suitable for use in either right or left-hand traffic or both right and left-hand traffic.

(<sup>c</sup>) Indicate whether the speedometer fitted has metric or both metric and imperial units.

(<sup>d</sup>) This statement shall not restrict the right of the Member States to require technical adaptations in order to allow the registration of a vehicle in a Member State other than the one for which it was intended when the direction of the traffic is on the opposite side of the road.

(<sup>e</sup>) This entry shall be only completed when the vehicle has two axles. [<sup>F40</sup> For a centre-axle trailer with one single axle, indicate the horizontal distance between the vertical axis of the coupling and the centre of the axle.]

(<sup>g</sup>) For hybrid electric vehicles, indicate both power outputs.

(<sup>h</sup>) Optional equipment under this letter can be added under entry 'Remarks'.

(<sup>i</sup>) The codes described in Annex II Letter C shall be used.

(<sup>j</sup>) Indicate only the basic colour(s) as follows: white, yellow, orange, red, violet, blue, green, grey, brown or black.

---

*Status: EU Directives are being published on this site to aid cross referencing from UK legislation. After IP completion day (31 December 2020 11pm) no further amendments will be applied to this version.*

---

- (<sup>k</sup>) Excluding seats designated for use only when the vehicle is stationary and the number of wheelchair positions.
- For coaches belonging to the vehicle category M<sub>3</sub> the number of crew members shall be included in the passenger number.
- (<sup>l</sup>) Add the number of the Euro level and the character corresponding to the provisions used for type-approval.
- [<sup>F6(m)</sup>] Repeat for the various fuels that can be used. Vehicles that can be fuelled with both petrol and gaseous fuel but in which the petrol system is fitted for emergency purposes or for starting only and the petrol tank of which cannot contain more than 15 litres of petrol will be regarded as vehicles that can only run on a gaseous fuel.]
- [<sup>F7(m1)</sup>] In case of EURO VI dual-fuel engines and vehicles, repeat as appropriate.
- (<sup>m2</sup>) Solely emissions assessed in accordance with the applicable regulatory act or acts shall be stated.]
- (<sup>n</sup>) If the vehicle is equipped with 24 GHz short-range radar equipment in accordance with Commission Decision 2005/50/EC ([OJ L 21, 25.1.2005, p. 15](#)), the manufacturer shall indicate here: ‘Vehicle equipped with 24 GHz short-range radar equipment’.
- (<sup>o</sup>) The manufacturer may complete these entries either for international traffic or national traffic or both.
- For national traffic, the code of the country where the vehicle is intended to be registered shall be mentioned. The code shall be in accordance with standard ISO 3166-1:2006.
- For international traffic, the directive number shall be referred to (e.g. ‘96/53/EC’ for Council Directive 96/53/EC).
- [<sup>F36(p)</sup>] Eco-innovations.
- (<sup>p1</sup>) The general code of the eco-innovation(s) shall consist of the following elements, each separated by a blank space:
- Code of the approval authority as set out in Annex VII;
  - Individual code of each eco-innovation fitted in the vehicle, indicated in chronological order of the Commission approval decisions.
- (E.g. the general code of three eco-innovations approved chronologically as 10, 15 and 16 and fitted to a vehicle certified by the German type-approval authority should be: ‘e1 10 15 16’.)
- (<sup>p2</sup>) Sum of the CO<sub>2</sub> emissions savings of each individual eco-innovation.]
- [<sup>F5(q)</sup>] In the case of completed vehicles of category N<sub>1</sub> within the scope of Regulation (EC) No 715/2007.]]

## [<sup>F27</sup> ANNEX X

### CONFORMITY OF PRODUCTION PROCEDURES

#### 0. Objectives



- 0.1. The conformity of production procedure aims to ensure that each produced vehicle, system, component and technical separate unit is in conformity with the approved type.
- 0.2. Procedures include inseparably the assessment of quality management systems, referred to below as ‘initial assessment’ and verification of the approval subject and product-related controls, referred to as ‘product conformity arrangements’.

#### 1. **Initial assessment**

- 1.1. The approval authority of a Member State shall verify the existence of satisfactory arrangements and procedures for ensuring effective control so that components, systems, separate technical units or vehicles when in production conform to the approved type.
- 1.2. Guidance for conducting assessments may be found in Standard EN ISO 19011:2002 — Guidelines for quality and/or environmental management systems auditing.
- 1.3. The requirements referred to in point 1.1 shall be verified to the satisfaction of the authority granting type-approval.

That authority shall be satisfied with the initial assessment and the product conformity arrangements at section 2 below, taking account as necessary of one of the arrangements described in points 1.3.1 to 1.3.3, or a combination of those arrangements in full or in part as appropriate.

- 1.3.1. The actual initial assessment and/or verification of product conformity arrangements shall be carried out by the approval authority granting the approval or an appointed body acting on behalf of the approval authority.
  - 1.3.1.1. When considering the extent of the initial assessment to be carried out, the approval authority may take account of available information relating to:
    - (a) the manufacturer’s certification described in point 1.3.3 below, which has not been qualified or recognised under that point;
    - (b) in the case of component or separate technical unit type-approval, quality system assessments performed in the component or separate technical unit manufacturer’s premises by vehicle manufacturer(s), according to one or more of the industry sector specifications satisfying the requirements in harmonised standard EN ISO 9001:2008.
  - 1.3.2. The actual initial assessment and/or verification of product conformity arrangements may also be carried out by the approval authority of another Member State or the appointed body designated for this purpose by the approval authority.
    - 1.3.2.1. In such a case, the approval authority of the other Member State shall prepare a statement of compliance outlining the areas and production facilities it has covered as relevant to the product(s) to be type-approved and to the regulatory acts according to which these products are to be type-approved.
    - 1.3.2.2. On receiving an application for a compliance statement from the approval authority of a Member State granting type-approval, the approval authority of another Member State shall send forthwith the statement of compliance or advise that it is not in a position to provide such a statement.

---

*Status: EU Directives are being published on this site to aid cross referencing from UK legislation. After IP completion day (31 December 2020 11pm) no further amendments will be applied to this version.*

---

1.3.2.3. The statement of compliance shall include at least the following:

(a) Group or company	(e.g. XYZ Automotive)
(b) Particular organisation	(e.g. European Division)
(c) Plants/ Sites	(e.g. Engine Plant 1 (United Kingdom) — Vehicle Plant 2 (Germany))
(d) Vehicle/ Component range	(e.g. All Category M <sub>1</sub> models)
(e) Areas assessed	(e.g. Engine assembly, body pressing and assembly, vehicle assembly)
(f) Documents examined	(e.g. Company and site quality manual and procedures)
(g) Date of the assessment	(e.g. Audit conducted from 18 to 30.5.2009)
(h) Planned monitoring visit	(e.g. October 2010)

1.3.3. The approval authority shall also accept the manufacturer's suitable certification to harmonised standard EN ISO 9001:2008 or an equivalent harmonised standard as satisfying the initial assessment requirements of point 1.3. The manufacturer shall provide details of the certification and undertake to inform the approval authority of any revisions to its validity or scope.

1.4. For the purpose of vehicle type-approval, the initial assessments carried out for granting approvals for systems, components and technical units of the vehicle need not be repeated but shall be completed by an assessment covering the locations and activities relating to the assembly of the whole vehicle not covered by the former assessments.

## 2. Product conformity arrangements

2.1. Every vehicle, system, component or separate technical unit approved pursuant to this Directive or a separate Directive or Regulation shall be so manufactured as to conform to the type approved by meeting the requirements of this Directive or the applicable regulatory acts listed in Annex IV.

2.2. The approval authority of a Member State shall verify the existence of adequate arrangements and documented control plans, to be agreed with the manufacturer for each approval, to carry out at specified intervals those tests or associated checks necessary to verify continued conformity with the approved type including specifically physical tests specified in the regulatory acts.

2.3. The holder of the type-approval shall, in particular:

2.3.1. ensure the existence and application of procedures for effective control of the conformity of products (vehicles, systems, components or separate technical units) to the approved type;

- 2.3.2. have access to the testing or other appropriate equipment necessary for checking the conformity to each approved type;
- 2.3.3. ensure that test or check results data are recorded and that annexed documents remain available for a period to be determined in agreement with the approval authority. This period shall not exceed 10 years;
- 2.3.4. analyse the results of each type of test or check, in order to verify and ensure the stability of the product characteristics, making allowance for variation of an industrial production;
- 2.3.5. ensure that for each type of product, at least the checks prescribed in this Directive and the tests prescribed in the applicable regulatory acts listed in Annex IV are carried out;
- 2.3.6. ensure that any set of samples or test pieces, giving evidence of non-conformity in the type of test or check in question gives rise to a further sampling and test or check. All the necessary steps shall be taken to restore conformity of the corresponding production;
- 2.3.7. in the case of vehicle type-approval, the checks referred to in point 2.3.5 shall at least consist in verifying the correct built specifications in relation to the approval and the information required for certificates of conformity given in Annex IX.

### 3. **Continued verification arrangements**

- 3.1. The authority which has granted type-approval may at any time verify the conformity control methods applied in each production facility.
  - 3.1.1. The normal arrangements shall be to monitor the continued effectiveness of the procedures laid down in Sections 1 and 2 (initial assessment and product conformity arrangements) of this Annex.
    - 3.1.1.1. Surveillance activities carried out by the technical services (qualified or recognised as required in point 1.3.3) shall be accepted as satisfying the requirements of point 3.1.1 with regard to the procedures established at initial assessment.
    - 3.1.1.2. The normal frequency of verifications by the approval authority (other than those referred to in point 3.1.1.1) shall be such as to ensure that the relevant controls applied in accordance with Sections 1 and 2 are reviewed over a period consistent with the climate of trust established by the approval authority.
- 3.2. At every review, records of tests or checks and records of production shall be made available to the inspector; in particular, records of those tests or checks documented as required in point 2.2.
- 3.3. The inspector may select samples at random to be tested in the manufacturer's laboratory or in the facilities of the technical service. In such a case only physical test shall be carried out. The minimum number of samples may be determined according to the results of the manufacturer's own verification.
- 3.4. Where the level of control appears unsatisfactory, or when it seems necessary to verify the validity of the tests carried out in accordance with point 3.2, the inspector shall select samples to be sent to a technical service to perform physical tests.

---

*Status: EU Directives are being published on this site to aid cross referencing from UK legislation. After IP completion day (31 December 2020 11pm) no further amendments will be applied to this version.*

---

- 3.5. Where unsatisfactory results are found during an inspection or a monitoring review, the approval authority shall ensure that all necessary steps are taken to restore conformity of production as rapidly as possible.]

[<sup>F17</sup>ANNEX XI

**NATURE OF AND PROVISIONS FOR THE EC TYPE-  
APPROVAL OF SPECIAL PURPOSE VEHICLES**

**Status:** EU Directives are being published on this site to aid cross referencing from UK legislation. After IP completion day (31 December 2020 11pm) no further amendments will be applied to this version.

## Appendix 1

**Motor-Caravans, Ambulances and Hearses**

Item	Subject	Regulatory act reference	M <sub>1</sub> ≤ 2 500 kg <sup>a</sup>	M <sub>1</sub> > 2 500 kg <sup>a</sup>	M <sub>2</sub>	M <sub>3</sub>
1	Permissible Sound level	Directive 70/157/EEC	H	G+H	G+H	G+H
2	Emissions (Euro 5 and 6) light duty vehicles/ access to information	Regulation (EC) 715/2007	Q <sup>(1)</sup>	G+Q <sup>(1)</sup>	G+Q <sup>(1)</sup>	
3	Fuel tanks/rear protective devices	Directive 70/221/EEC	F <sup>(2)</sup>	F <sup>(2)</sup>	F <sup>(2)</sup>	F <sup>(2)</sup>
3A	Prevention of fire risks (liquid fuel tanks)	Regulation (EC) No 661/2009 UNECE Regulation No 34	F <sup>(2)</sup>	F <sup>(2)</sup>	F <sup>(2)</sup>	F <sup>(2)</sup>
3B	Rear underrun protective devices (RUPDs) and their installation; rear underrun protection (RUP)	Regulation (EC) No 661/2009 UNECE Regulation No 58	X	X	X	X
4	Rear registration plate space	Directive 70/222/EEC	X	X	X	X
4A	Space for mounting and fixing rear registration plates	Regulation (EC) No 661/2009 Regulation (EU) No 1003/2010	X	X	X	X

**a** Technically permissible maximum laden mass

*Status: EU Directives are being published on this site to aid cross referencing from UK legislation. After IP completion day (31 December 2020 11pm) no further amendments will be applied to this version.*

5	Steering effort	Directive 70/311/EEC	X	G	G	G
5A	Steering equipment	Regulation (EC) No 661/2009 UNECE Regulation No 79	X	G	G	G
6	Door latches and hinges	Directive 70/387/EEC	B	G+B		
6A	Vehicle access and manoeuvrability	Regulation (EC) No 661/2009 Regulation (EU) No 130/2012	X	X		
6B	Door latches and door retention components	Regulation (EC) No 661/2009 UNECE Regulation No 11	B	G+B		
7	Audible warning	Directive 70/388/EEC	X	X	X	X
7A	Audible warning devices and signals	Regulation (EC) No 661/2009 UNECE Regulation No 28	X	X	X	X
8	Devices for indirect vision	Directive 2003/97/EC	X	G	G	G
8A	Devices for indirect vision and their installation	Regulation (EC) No 661/2009 UNECE Regulation No 46	X	G	G	G
9	Braking	Directive 71/320/EEC	X	G	G	G

**a** Technically permissible maximum laden mass

**Status:** EU Directives are being published on this site to aid cross referencing from UK legislation. After IP completion day (31 December 2020 11pm) no further amendments will be applied to this version.

9A	Braking of vehicles and trailers	Regulation (EC) No 661/2009 UNECE Regulation No 13-H	X <sup>(4)</sup>	G+A <sub>1</sub>		
9B	Braking of vehicles and trailers	Regulation (EC) No 661/2009 UNECE Regulation No 13			G <sup>(3)</sup>	G <sup>(3)</sup>
10	Radio interference (electromagnetic compatibility)	Directive 72/245/EEC	X	X	X	X
10A	Electromagnetic compatibility	Regulation (EC) No 661/2009 UNECE Regulation No 10	X	X	X	X
12	Interior fittings	Directive 74/60/EEC	C	G+C		
12A	Interior fittings	Regulation (EC) No 661/2009 UNECE Regulation No 21	C	G+C		
13	Anti-theft and immobiliser	Directive 74/61/EEC	X	G	G	G
13A	Protection of motor vehicles against unauthorised use	Regulation (EC) No 661/2009 UNECE Regulation No 18			G <sup>(4A)</sup>	G <sup>(4A)</sup>
13B	Protection of motor vehicles against unauthorised use	Regulation (EC) No 661/2009 UNECE Regulation No 116	X	G		

**a** Technically permissible maximum laden mass

*Status: EU Directives are being published on this site to aid cross referencing from UK legislation. After IP completion day (31 December 2020 11pm) no further amendments will be applied to this version.*

14	Protective steering	Directive 74/297/EEC	X	G		
14A	Protection of the driver against the steering mechanism in the event of impact	Regulation (EC) No 661/2009 UNECE Regulation No 12	X	G		
15	Seat strength	Directive 74/408/EEC	D	G+D	G+D	G+D
15A	Seats, their anchorages and any head restraints	Regulation (EC) No 661/2009 UNECE Regulation No 17	D	G+D	G+D <sup>(4B)</sup>	G+D <sup>(4B)</sup>
15B	Seats of large passenger vehicles	Regulation (EC) No 661/2009 UNECE Regulation No 80			X	X
16	Exterior projections	Directive 74/483/EEC	X for the cab; A +Z for the remaining part	G for the cab; A +Z for the remaining part		
16A	External projections	Regulation (EC) No 661/2009 UNECE Regulation No 26	X for the cab; A +Z for the remaining part	G for the cab; A +Z for the remaining part		
17	Speedometer and reverse gear	Directive 75/443/EEC	X	X	X	X
17A	Vehicle access and manoeuvrability	Regulation (EC) No 661/2009 Regulation (EU) No 130/2012	X	X	X	X

**a** Technically permissible maximum laden mass



**Status:** EU Directives are being published on this site to aid cross referencing from UK legislation. After IP completion day (31 December 2020 11pm) no further amendments will be applied to this version.

17B	Speedometer equipment including its installation	Regulation (EC) No 661/2009 UNECE Regulation No 39	X	X	X	X
18	Plates (statutory)	Directive 76/114/EEC	X	X	X	X
18A	Manufacturer's statutory plate and vehicle identification number	Regulation (EC) No 661/2009 Regulation (EU) No 19/2011	X	X	X	X
19	Seat belt anchorages	Directive 76/115/EEC	D	G+L	G+L	G+L
19A	Safety-belt anchorages, Isofix anchorages systems and Isofix top tether anchorages	Regulation (EC) No 661/2009 UNECE Regulation No 14	D	G+L	G+L	G+L
20	Installation of lighting and light signalling devices	Directive 76/756/EEC	A+N	A+G+N for the cab; A+N for the remaining part	A+G+N for the cab; A+N for the remaining part	A+G+N for the cab; A+N for the remaining part
20A	Installation of lighting and light-signalling devices on vehicles	Regulation (EC) No 661/2009 UNECE Regulation No 48	A+N	A+G+N for the cab; A+N for the remaining part	A+G+N for the cab; A+N for the remaining part	A+G+N for the cab; A+N for the remaining part
21	Retro reflectors	Directive 76/757/EEC	X	X	X	X
21A	Retro-reflecting devices for power-driven vehicles	Regulation (EC) No 661/2009 UNECE Regulation No 3	X	X	X	X

**a** Technically permissible maximum laden mass

*Status: EU Directives are being published on this site to aid cross referencing from UK legislation. After IP completion day (31 December 2020 11pm) no further amendments will be applied to this version.*

	and their trailers					
22	End-outline, front-side, rear-side, stop, day time running, side-marker lamps	Directive 76/758/EEC	X	X	X	X
22A	Front and rear position lamps, stop-lamps and end-outline marker lamps for motor vehicles and their trailers	Regulation (EC) No 661/2009 UNECE Regulation No 7	X	X	X	X
22B	Daytime running lamps for power-driven vehicles	Regulation (EC) No 661/2009 UNECE Regulation No 87	X	X	X	X
22C	Side-marker lamps for motor vehicles and their trailers	Regulation (EC) No 661/2009 UNECE Regulation No 91	X	X	X	X
23	Direction indicators	Directive 76/759/EEC	X	X	X	X
23A	Direction indicators for power-driven vehicles and their trailers	Regulation (EC) No 661/2009 UNECE Regulation No 6	X	X	X	X

**a** Technically permissible maximum laden mass

**Status:** EU Directives are being published on this site to aid cross referencing from UK legislation. After IP completion day (31 December 2020 11pm) no further amendments will be applied to this version.

24	Rear registration plate lamps	Directive 76/760/EEC	X	X	X	X
24A	Illumination of rear-registration plates of power-driven vehicles and their trailers	Regulation (EC) No 661/2009 UNECE Regulation No 4	X	X	X	X
25	Head lamps (including bulbs)	Directive 76/761/EEC	X	X	X	X
25A	Power-driven vehicle's sealed-beam headlamps (SB) emitting an European asymmetrical passing beam or a driving beam or both	Regulation (EC) No 661/2009 UNECE Regulation No 31	X	X	X	X
25B	Filament lamps for use in approved lamp units of power-driven vehicles and their trailers	Regulation (EC) No 661/2009 UNECE Regulation No 37	X	X	X	X
25C	Motor vehicle headlamps equipped with gas-discharge light sources	Regulation (EC) No 661/2009 UNECE Regulation No 98	X	X	X	X

**a** Technically permissible maximum laden mass

*Status: EU Directives are being published on this site to aid cross referencing from UK legislation. After IP completion day (31 December 2020 11pm) no further amendments will be applied to this version.*

25D	Gas-discharge light sources for use in approved gas-discharge lamp units of power-driven vehicles	Regulation (EC) No 661/2009 UNECE Regulation No 99	X	X	X	X
25E	Motor vehicle headlamps emitting an asymmetrical passing beam or a driving beam or both and equipped with filament lamps and/or LED modules	Regulation (EC) No 661/2009 UNECE Regulation No 112	X	X	X	X
25F	Adaptive front-lighting systems (AFS) for motor vehicles	Regulation (EC) No 661/2009 UNECE Regulation No 123	X	X	X	X
26	Front fog lamps	Directive 76/762/EEC	X	X	X	X
26A	Power-driven vehicle front fog lamps	Regulation (EC) No 661/2009 UNECE Regulation No 19	X	X	X	X
27	Towing hooks	Directive 77/389/EEC	E	E	E	E

**a** Technically permissible maximum laden mass

**Status:** EU Directives are being published on this site to aid cross referencing from UK legislation. After IP completion day (31 December 2020 11pm) no further amendments will be applied to this version.

27A	Towing device	Regulation (EC) No 661/2009 Regulation (EU) No 1005/2010	E	E	E	E
28	Rear fog lamps	Directive 77/538/EEC	X	X	X	X
28A	Rear fog lamps for power-driven vehicles and their trailers	Regulation (EC) No 661/2009 UNECE Regulation No 38	X	X	X	X
29	Reversing lamps	Directive 77/539/EEC	X	X	X	X
29A	Reversing lights for power-driven vehicles and their trailers	Regulation (EC) No 661/2009 UNECE Regulation No 23	X	X	X	X
30	Parking lamps	Directive 77/540/EEC	X	X	X	X
30A	Parking lamps for power-driven vehicles	Regulation (EC) No 661/2009 UNECE Regulation No 77	X	X	X	X
31	Seat belts and restraint systems	Directive 77/541/EEC	D	G+M	G+M	G+M
31A	Safety-belts, restraint systems, child restraint systems and Isofix	Regulation (EC) No 661/2009 UNECE Regulation No 16	D	G+M	G+M	G+M

**a** Technically permissible maximum laden mass

*Status: EU Directives are being published on this site to aid cross referencing from UK legislation. After IP completion day (31 December 2020 11pm) no further amendments will be applied to this version.*

	child restraint systems					
32	Forward vision	Directive 77/649/EEC	X	G		
32A	Forward field of vision	Regulation (EC) No 661/2009 UNECE Regulation No 125	X	G		
33	Identification of controls, tell-tales and indicators	Directive 78/316/EEC	X	X	X	X
33A	Location and identification of hand controls, tell-tales and indicators	Regulation (EC) No 661/2009 UNECE Regulation No 121	X	X	X	X
34	Defrost/demist	Directive 78/317/EEC	X	G <sup>(5)</sup>	( <sup>5</sup> )	( <sup>5</sup> )
34A	Windscreen defrosting and demisting systems	Regulation (EC) No 661/2009 Regulation (EU) No 672/2010	X	G <sup>(5)</sup>	( <sup>5</sup> )	( <sup>5</sup> )
35	Wash/wipe	Directive 78/318/EEC	X	G <sup>(6)</sup>	( <sup>6</sup> )	( <sup>6</sup> )
35A	Windscreen wiper and washer systems	Regulation (EC) No 661/2009 Regulation (EU) No 1008/2010	X	G <sup>(6)</sup>	( <sup>6</sup> )	( <sup>6</sup> )
36	Heating systems	Directive 2001/56/EC	X	X	X	X

**a** Technically permissible maximum laden mass

**Status:** EU Directives are being published on this site to aid cross referencing from UK legislation. After IP completion day (31 December 2020 11pm) no further amendments will be applied to this version.

36A	Heating systems	Regulation (EC) No 661/2009 UNECE Regulation No 122	X	X	X	X
37	Wheel guards	Directive 78/549/EEC	X	G		
37A	Wheel guards	Regulation (EC) No 661/2009 Regulation (EU) No 1009/2010	X	G		
38	Head restraints	Directive 78/932/EEC	D	G+D		
38A	Head restraints (headrests), whether or not incorporated in vehicle seats	Regulation (EC) No 661/2009 UNECE Regulation No 25	D	G+D	A	A
41	Emissions (Euro IV and V) heavy duty vehicles	Directive 2005/55/EC	H <sup>(8)</sup>	G+H <sup>(8)</sup>	G+H <sup>(8)</sup>	G+H <sup>(8)</sup>
41A	Emissions (Euro VI) heavy duty vehicles/ access to information	Regulation (EC) No 595/2009	G+H <sup>(9)</sup>	G+H <sup>(9)</sup>	G+H <sup>(9)</sup>	G+H <sup>(9)</sup>
44	Masses and dimensions (cars)	Directive 92/21/EEC	X	X		
44A	Masses and dimensions	Regulation (EC) No 661/2009 Regulation (EU) No 1230/2012	X	X		

**a** Technically permissible maximum laden mass

*Status: EU Directives are being published on this site to aid cross referencing from UK legislation. After IP completion day (31 December 2020 11pm) no further amendments will be applied to this version.*

45	Safety glazing	Directive 92/22/EEC	J	G+J	G+J	G+J
45A	Safety glazing materials and their installation on vehicles	Regulation (EC) No 661/2009 UNECE Regulation No 43	J	G+J	G+J	G+J
46	Tyres	Directive 92/23/EEC	X	G	G	G
46A	Installation of tyres	Regulation (EC) No 661/2009 Regulation (EU) No 458/2011	X	G	G	G
46B	Pneumatic tyres for motor vehicles and their trailers (Class C1)	Regulation (EC) No 661/2009 UNECE Regulation No 30	X	G		
46C	Pneumatic tyres for commercial vehicles and their trailers (Classes C2 and C3)	Regulation (EC) No 661/2009 UNECE Regulation No 54	—	G	G	G
46D	Tyre rolling sound emissions, adhesion on wet surfaces and rolling resistance (Classes C1, C2 and C3)	Regulation (EC) No 661/2009 UNECE Regulation No 117	X	G	G	G
46E	Temporary-use spare unit, run-flat tyres/system	Regulation (EC) No 661/2009	X	G		

**a** Technically permissible maximum laden mass



**Status:** EU Directives are being published on this site to aid cross referencing from UK legislation. After IP completion day (31 December 2020 11pm) no further amendments will be applied to this version.

	and tyre pressure monitoring system	UNECE Regulation No 64				
47	Speed limitation devices	Directive 92/24/EEC			X	X
47A	Speed limitation of vehicles	Regulation (EC) No 661/2009 UNECE Regulation No 89			X	X
48	Masses and dimensions (other than vehicles referred to in item 44)	Directive 97/27/EC			X	X
48A	Masses and dimensions	Regulation (EC) No 661/2009 Regulation (EU) No 1230/2012			X	X
50	Couplings	Directive 94/20/EC	X <sup>(10)</sup>	G <sup>(10)</sup>	G <sup>(10)</sup>	G <sup>(10)</sup>
50A	Mechanical coupling components of combinations of vehicles	Regulation (EC) No 661/2009 UNECE Regulation No 55	X <sup>(10)</sup>	G <sup>(10)</sup>	G <sup>(10)</sup>	G <sup>(10)</sup>
51	Flammability	Directive 95/28/EC				G for the cab; X for the remaining part
51A	Burning behaviour of materials used in the interior construction of certain categories	Regulation (EC) No 661/2009 UNECE Regulation No 118				G for the cab; X for the remaining part

**a** Technically permissible maximum laden mass

*Status: EU Directives are being published on this site to aid cross referencing from UK legislation. After IP completion day (31 December 2020 11pm) no further amendments will be applied to this version.*

	of motor vehicles					
52	Buses and coaches	Directive 2001/85/EC			A	A
52A	M <sub>2</sub> and M <sub>3</sub> vehicles	Regulation (EC) No 661/2009 UNECE Regulation No 107			A	A
52B	Strength of the superstructure of large passenger vehicles	Regulation (EC) No 661/2009 UNECE Regulation No 66			A	A
53	Frontal impact	Directive 96/79/EC	N/A	N/A		
53A	Protection of occupants in the event of a frontal collision	Regulation (EC) No 661/2009 UNECE Regulation No 94	N/A	N/A		
54	Side impact	Directive 96/27/EC	N/A	N/A		
54A	Protection of occupants in the event of lateral collision	Regulation (EC) No 661/2009 UNECE Regulation No 95	N/A	N/A		
58	Pedestrian protection	Regulation (EC) No 78/2009	X	N/A. However, any frontal protection systems supplied with the vehicle shall comply and shall be marked		

**a** Technically permissible maximum laden mass

**Status:** EU Directives are being published on this site to aid cross referencing from UK legislation. After IP completion day (31 December 2020 11pm) no further amendments will be applied to this version.

59	Recyclability	Directive 2005/64/EC	N/A	N/A		
61	Air-conditioning system	Directive 2006/40/EC	X	G <sup>(14)</sup>		
62	Hydrogen system	Regulation (EC) No 79/2009	X	X	X	X
63	General Safety	Regulation (EC) No 661/2009	X <sup>(15)</sup>	X <sup>(15)</sup>	X <sup>(15)</sup>	X <sup>(15)</sup>
64	Gear shift indicators	Regulation (EC) No 661/2009 Regulation (EU) No 65/2012	X	G		
65	Advanced emergency braking system	Regulation (EC) No 661/2009 Regulation (EU) No 347/2012			N/A <sup>(16)</sup>	N/A <sup>(16)</sup>
66	Lane departure warning system	Regulation (EC) No 661/2009 Regulation (EU) No 351/2012			N/A <sup>(17)</sup>	N/A <sup>(17)</sup>
67	Specific components for liquefied petroleum gases (LPG) and their installation on motor vehicles	Regulation (EC) No 661/2009 UNECE Regulation No 67	X	X	X	X
68	Vehicle alarm systems (VAS)	Regulation (EC) No 661/2009 UNECE Regulation No 97	X	G		

**a** Technically permissible maximum laden mass

---

*Status: EU Directives are being published on this site to aid cross referencing from UK legislation. After IP completion day (31 December 2020 11pm) no further amendments will be applied to this version.*

---

69	Electrical safety	Regulation (EC) No 661/2009 UNECE Regulation No 100	X	X	X	X
70	Specific components for CNG and their installation on motor vehicles	Regulation (EC) No 661/2009 UNECE Regulation No 110	X	X	X	X

**a** Technically permissible maximum laden mass

---

### **Additional requirements for ambulances**

The patient compartment of ambulances shall comply with the requirements of EN 1789:2007 +A1: 2010 +A2:2014 on Medical vehicles and their equipment – Road ambulances with the exception of Section 6.5, list of equipment. Proof of compliance shall be provided with a test report of a technical service. If a Wheelchair space is foreseen, the requirements of Appendix 3 relating to the wheelchair tie down and occupant restraint systems shall apply.



*Status: EU Directives are being published on this site to aid cross referencing from UK legislation. After IP completion day (31 December 2020 11pm) no further amendments will be applied to this version.*

4A	Space for mounting and fixing rear registration plates	Regulation (EC) No 661/2009 Regulation (EU) No 1003/2010	X	X	X	X	X	X	X	X	X	X
5	Steering effort	Directive 70/311/EEC	X	X	X	X	X	X	X	X	X	X
5A	Steering equipment	Regulation (EC) No 661/2009 UNECE Regulation No 79	X	X	X	X	X	X	X	X	X	X
6	Door latches and hinges	Directive 70/387/EEC			X	X	X					
6A	Vehicle access and manoeuvring	Regulation (EC) No 661/2009 Regulation (EU) No 130/2012	X	X	X	X	X					
6B	Door latches and door retention components	Regulation (EC) No 661/2009 UNECE Regulation No 11			X							
7	Audible warning	Directive 70/388/EEC	A+K	A+K	A+K	A+K	A+K					
7A	Audible warning devices and signals	Regulation (EC) No 661/2009 UNECE Regulation	A+K	A+K	A+K	A+K	A+K					



*Status: EU Directives are being published on this site to aid cross referencing from UK legislation. After IP completion day (31 December 2020 11pm) no further amendments will be applied to this version.*

12A	Interior fittings	Regulation (EC) No 661/2009 UNECE Regulation No 21	X	X	X	X	X				
13	Anti-theft and immobiliser	Directive 74/61/EEC	X	X	X	X	X				
13A	Protection of motor vehicle against unauthorised use	Regulation (EC) No 661/2009 UNECE Regulation No 18	X <sup>(4A)</sup>	X <sup>(4A)</sup>		X <sup>(4A)</sup>	X <sup>(4A)</sup>				
13B	Protection of motor vehicle against unauthorised use	Regulation (EC) No 661/2009 UNECE Regulation No 116			X						
14	Protection of steering	Directive 74/297/EEC			N/A						
14A	Protection of the driver against the steering mechanism in the event of impact	Regulation (EC) No 661/2009 UNECE Regulation No 12			N/A						
15	Seat strength	Directive 74/408/EEC	D	D	D	D	D				
15A	Seats, their anchorages and	Regulation (EC) No 661/2009	D <sup>(4B)</sup>	D <sup>(4B)</sup>	D	D	D				









*Status: EU Directives are being published on this site to aid cross referencing from UK legislation. After IP completion day (31 December 2020 11pm) no further amendments will be applied to this version.*

23	Directive 76/759/EEC	Directive 76/759/EEC	X	X	X	X	X	X	X	X	X
23A	Directive for power-driven vehicles and their trailers	Regulation (EC) No 661/2009 UNECE Regulation No 6	X	X	X	X	X	X	X	X	X
24	Rear registration plate lamps	Directive 76/760/EEC	X	X	X	X	X	X	X	X	X
24A	Illumination of rear-registration plates of power-driven vehicles and their trailers	Regulation (EC) No 661/2009 UNECE Regulation No 4	X	X	X	X	X	X	X	X	X
25	Headlamps (including bulbs)	Directive 76/761/EEC	X	X	X	X	X				
25A	Power-driven vehicle sealed-beam headlamps (SB) emitting an European asymmetrical passing beam or a driving beam or both	Regulation (EC) No 661/2009 UNECE Regulation No 31	X	X	X	X	X				

*Status: EU Directives are being published on this site to aid cross referencing from UK legislation. After IP completion day (31 December 2020 11pm) no further amendments will be applied to this version.*

25B	Filament lamps for use in approved lamp units of power-driven vehicles and their trailers	Regulation (EC) No 661/2009 UNECE Regulation No 37	X	X	X	X	X	X	X	X	X
25C	Motor vehicle headlamps equipped with gas-discharge light sources	Regulation (EC) No 661/2009 UNECE Regulation No 98	X	X	X	X	X				
25D	Gas-discharge light sources for use in approved gas-discharge lamp units of power-driven vehicles	Regulation (EC) No 661/2009 UNECE Regulation No 99	X	X	X	X	X				
25E	Motor vehicle headlamps emitting an asymmetric passing beam or a driving beam	Regulation (EC) No 661/2009 UNECE Regulation No 112	X	X	X	X	X				





*Status: EU Directives are being published on this site to aid cross referencing from UK legislation. After IP completion day (31 December 2020 11pm) no further amendments will be applied to this version.*

32A	Forward field of vision	Regulation (EC) No 661/2009 UNECE Regulation No 125									
33	Identification of controls, tell-tales and indicators	Directive 78/316/EEC	X	X	X	X	X				
33A	Location and identification of hand controls, tell-tales and indicators	Regulation (EC) No 661/2009 UNECE Regulation No 121	X	X	X	X	X				
34	Defrosting demisters	Directive 78/317/EEC	( <sup>6</sup> )	( <sup>6</sup> )	( <sup>6</sup> )	( <sup>6</sup> )	( <sup>6</sup> )				
34A	Windscreens defrosting and demisting systems	Regulation (EC) No 661/2009 Regulation (EU) No 672/2010	( <sup>6</sup> )	( <sup>6</sup> )	( <sup>6</sup> )	( <sup>6</sup> )	( <sup>6</sup> )				
35	Wash/wipe	Directive 78/318/EEC	( <sup>6</sup> )	( <sup>6</sup> )	( <sup>6</sup> )	( <sup>6</sup> )	( <sup>6</sup> )				
35A	Windscreens wiper and washer systems	Regulation (EC) No 661/2009 Regulation (EU) No 1008/2010	( <sup>6</sup> )	( <sup>6</sup> )	( <sup>6</sup> )	( <sup>6</sup> )	( <sup>6</sup> )				



*Status: EU Directives are being published on this site to aid cross referencing from UK legislation. After IP completion day (31 December 2020 11pm) no further amendments will be applied to this version.*

36	Heating systems	Directive 2001/56/EC	X	X	X	X	X	X	X	X	X	X
36A	Heating systems	Regulation (EC) No 661/2009 UNECE Regulation No 122	X	X	X	X	X	X	X	X	X	X
37	Wheel guards	Directive 78/549/EEC										
37A	Wheel guards	Regulation (EC) No 661/2009 Regulation (EU) No 1009/2010										
38	Head restraints	Directive 78/932/EEC										
38A	Head restraints (headrests), whether or not incorporated in vehicle seats	Regulation (EC) No 661/2009 UNECE Regulation No 25										
41	Emissions (Euro IV and V) heavy duty vehicles.	Directive (8) 2005/55/EC	X (8)	X	X (8)	X (8)	X					
41A	Emissions (Euro VI) heavy duty vehicles/	Regulation (EC) No 595/2009	X (9)	X	X (9)	X (9)	X					





*Status: EU Directives are being published on this site to aid cross referencing from UK legislation. After IP completion day (31 December 2020 11pm) no further amendments will be applied to this version.*

46E	Temporary use spare unit, run-flat tyres/system and tyre pressure monitoring system	Regulation (EC) No 661/2009 UNECE Regulation No 64			A <sup>(9A)</sup>						
47	Speed limitation devices	Directive 91/24/EEC	X	X		X	X				
47A	Speed limitation of vehicles	Regulation (EC) No 661/2009 UNECE Regulation No 89	X	X		X	X				
48	Masses and dimensions (other than vehicles referred to in item 44)	Directive 97/27/EC	X	X	X	X	X	X	X	X	X
48A	Masses and dimensions	Regulation (EC) No 661/2009 Regulation (EU) No 1230/2012	X	X	X	X	X	X	X	X	X
49	External projections of cabs	Directive 92/114/EEC			A	A	A				
49A	Commercial vehicles with	Regulation (EC)			A	A	A				

**Status:** EU Directives are being published on this site to aid cross referencing from UK legislation. After IP completion day (31 December 2020 11pm) no further amendments will be applied to this version.

	regard to their external project forward of the cab's rear panel	No 661/2009 UNECE Regulation No 61									
50	Coupling	Directive 94/20/ EC ( <sup>10</sup> )	X ( <sup>10</sup> )	X ( <sup>10</sup> )	X ( <sup>10</sup> )	X ( <sup>10</sup> )	X ( <sup>10</sup> )	X	X	X	X
50A	Mechanical coupling components of combination of vehicle	Regulation (EC) No 661/2009 UNECE Regulation No 55	X ( <sup>10</sup> )	X ( <sup>10</sup> )	X ( <sup>10</sup> )	X ( <sup>10</sup> )	X ( <sup>10</sup> )	X	X	X	X
50B	Close-coupling device (CCD) fitting of an approved type of CCD	Regulation (EC) No 661/2009 UNECE Regulation No 102				X ( <sup>10</sup> )	X ( <sup>10</sup> )			X ( <sup>10</sup> )	X ( <sup>10</sup> )
51	Flammable	Directive 95/28/ EC		X							
51A	Burning behaviour of materials used in the interior construction of certain categories of motor vehicles	Regulation (EC) No 661/2009 UNECE Regulation No 118		X							





*Status: EU Directives are being published on this site to aid cross referencing from UK legislation. After IP completion day (31 December 2020 11pm) no further amendments will be applied to this version.*

		No 661/2009 Regulation (EU) No 65/2012									
65	Advanced emergency braking system	Regulation (EC) No 661/2009 Regulation (EU) No 347/2012	( <sup>16</sup> )	( <sup>16</sup> )		( <sup>16</sup> )	( <sup>16</sup> )				
66	Lane departure warning system	Regulation (EC) No 661/2009 Regulation (EU) No 351/2012	( <sup>17</sup> )	( <sup>17</sup> )		( <sup>17</sup> )	( <sup>17</sup> )				
67	Specific components for liquefied petroleum gases (LPG) and their installation on motor vehicles	Regulation (EC) No 661/2009 UNECE Regulation No 67	X	X	X	X	X				
68	Vehicle alarm systems (VAS)	Regulation (EC) No 661/2009 UNECE Regulation No 97			X						
69	Electrical safety	Regulation (EC) No 661/2009 UNECE Regulation	X	X	X	X	X				



---

**Status:** EU Directives are being published on this site to aid cross referencing from UK legislation. After IP completion day (31 December 2020 11pm) no further amendments will be applied to this version.

---

		No 100										
70	Specific Regulation (EC) for CNG and their installation on motor vehicles	Regulation No 661/2009 UNECE Regulation No 110	X	X	X	X	X					

*Status: EU Directives are being published on this site to aid cross referencing from UK legislation. After IP completion day (31 December 2020 11pm) no further amendments will be applied to this version.*

## Appendix 3

## Wheel-chair Accessible Vehicles

Item	Subject	Regulatory act	M <sub>1</sub>
1	Permissible sound level	Directive 70/157/EEC	G+W <sub>0</sub>
2	Emissions (Euro 5 and 6) light duty vehicles/access to information	Regulation (EC) No 715/2007	G+W <sub>1</sub>
3	Fuel tanks/rear protective devices	Directive 70/221/EEC	X+W <sub>2</sub>
3A	Prevention of fire risks (liquid fuel tanks)	Regulation (EC) No 661/2009 UNECE Regulation No 34	X+W <sub>2</sub>
3B	Rear underrun protective devices (RUPDs) and their installation; rear underrun protection (RUP)	Regulation (EC) No 661/2009 UNECE Regulation No 58	X
4	Rear registration plate space	Directive 70/222/EEC	X
4A	Space for mounting and fixing rear registration plates	Regulation (EC) No 661/2009 Regulation (EU) No 1003/2010	X
5	Steering effort	Directive 70/311/EEC	G
5A	Steering equipment	Regulation (EC) No 661/2009 UNECE Regulation No 79	G
6	Door latches and hinges	Directive 70/387/EEC	X
6A	Vehicle access and manoeuvrability	Regulation (EC) No 661/2009 Regulation (EU) No 130/2012	X
6B	Door latches and door retention components	Regulation (EC) No 661/2009 UNECE Regulation No 11	X
7	Audible warning	Directive 70/388/EEC	X

**Status:** EU Directives are being published on this site to aid cross referencing from UK legislation. After IP completion day (31 December 2020 11pm) no further amendments will be applied to this version.

7A	Audible warning devices and signals	Regulation (EC) No 661/2009 UNECE Regulation No 28	X
8	Indirect vision devices	Directive 2003/97/EC	X
8A	Devices for indirect vision and their installation	Regulation (EC) No 661/2009 UNECE Regulation No 46	X
9	Braking	Directive 71/320/EEC	G
9B	Braking of passenger cars	Regulation (EC) No 661/2009 UNECE Regulation No 13-H	G+A <sub>1</sub>
10	Radio interference (electromagnetic compatibility)	Directive 72/245/EEC	X
10A	Electromagnetic compatibility	Regulation (EC) No 661/2009 UNECE Regulation No 10	X
12	Interior fittings	Directive 74/60/EEC	G+C
12A	Interior fittings	Regulation (EC) No 661/2009 UNECE Regulation No 21	G+C
13	Anti-theft and immobiliser	Directive 74/61/EEC	X
13B	Protection of motor vehicles against unauthorised use	Regulation (EC) No 661/2009 UNECE Regulation No 116	X
14	Protective steering	Directive 74/297/EEC	G
14A	Protection of the driver against the steering mechanism in the event of impact	Regulation (EC) No 661/2009 UNECE Regulation No 12	G
15	Seat strength	Directive 74/408/EEC	G+W <sub>3</sub>
15A	Seats, their anchorages and any head restraints	Regulation (EC) No 661/2009	G+W <sub>3</sub>

*Status: EU Directives are being published on this site to aid cross referencing from UK legislation. After IP completion day (31 December 2020 11pm) no further amendments will be applied to this version.*

		UNECE Regulation No 17	
16	Exterior projections	Directive 74/483/EEC	G+W <sub>4</sub>
16A	External projections	Regulation (EC) No 661/2009 UNECE Regulation No 26	G+W <sub>4</sub>
17	Speedometer and reverse gear	Directive 75/443/EEC	X
17A	Vehicle access and manoeuvrability	Regulation (EC) No 661/2009 Regulation (EU) No 130/2012	X
17B	Speedometer equipment including its installation	Regulation (EC) No 661/2009 UNECE Regulation No 39	X
18	Statutory plates	Directive 76/114/EEC	X
18A	Manufacturer's statutory plate and vehicle identification number	Regulation (EC) No 661/2009 Regulation (EU) No 19/2011	X
19	Seat belt anchorages	Directive 76/115/EEC	X+W <sub>5</sub>
19A	Safety-belt anchorages, Isofix anchorages systems and Isofix top tether anchorages	Regulation (EC) No 661/2009 UNECE Regulation No 14	X+W <sub>5</sub>
20	Installation of lighting and light signalling devices	Directive 76/756/EEC	X
20A	Installation of lighting and light-signalling devices on vehicles	Regulation (EC) No 661/2009 UNECE Regulation No 48	X
21	Retro reflectors	Directive 76/757/EEC	X
21A	Retro-reflecting devices for power-driven vehicles and their trailers	Regulation (EC) No 661/2009 UNECE Regulation No 3	X

**Status:** EU Directives are being published on this site to aid cross referencing from UK legislation. After IP completion day (31 December 2020 11pm) no further amendments will be applied to this version.

22	End-outline, front-position (side), rear-position (side), stop, side marker, daytime running lamps	Directive 76/758/EEC	X
22A	Front and rear position lamps, stop-lamps and end-outline marker lamps for motor vehicles and their trailers	Regulation (EC) No 661/2009 UNECE Regulation No 7	X
22B	Daytime running lamps for power-driven vehicles	Regulation (EC) No 661/2009 UNECE Regulation No 87	X
22C	Side-marker lamps for motor vehicles and their trailers	Regulation (EC) No 661/2009 UNECE Regulation No 91	X
23	Direction indicators	Directive 76/759/EEC	X
23A	Direction indicators for power-driven vehicles and their trailers	Regulation (EC) No 661/2009 UNECE Regulation No 6	X
24	Rear registration plate lamps	Directive 76/760/EEC	X
24A	Illumination of rear-registration plates of power-driven vehicles and their trailers	Regulation (EC) No 661/2009 UNECE Regulation No 4	X
25	Headlamps (including bulbs)	Directive 76/761/EEC	X
25A	Power-driven vehicle's sealed-beam headlamps (SB) emitting an European asymmetrical passing beam or a driving beam or both	Regulation (EC) No 661/2009 UNECE Regulation No 31	X
25B	Filament lamps for use in approved lamp units of power-driven vehicles and their trailers	Regulation (EC) No 661/2009 UNECE Regulation No 37	X

*Status: EU Directives are being published on this site to aid cross referencing from UK legislation. After IP completion day (31 December 2020 11pm) no further amendments will be applied to this version.*

25C	Motor vehicle headlamps equipped with gas-discharge light sources	Regulation (EC) No 661/2009 UNECE Regulation No 98	X
25D	Gas-discharge light sources for use in approved gas-discharge lamp units of power-driven vehicles	Regulation (EC) No 661/2009 UNECE Regulation No 99	X
25E	Motor vehicle headlamps emitting an asymmetrical passing beam or a driving beam or both and equipped with filament lamps and/or LED modules	Regulation (EC) No 661/2009 UNECE Regulation No 112	X
25F	Adaptive front-lighting systems (AFS) for motor vehicles	Regulation (EC) No 661/2009 UNECE Regulation No 123	X
26	Front fog lamps	Directive 76/762/EEC	X
26A	Power-driven vehicle front fog lamps	Regulation (EC) No 661/2009 UNECE Regulation No 19	X
27	Towing hooks	Directive 77/389/EEC	E
27A	Towing device	Regulation (EC) No 661/2009 Regulation (EU) No 1005/2010	E
28	Rear fog lamps	Directive 77/538/EEC	X
28A	Rear fog lamps for power-driven vehicles and their trailers	Regulation (EC) No 661/2009 UNECE Regulation No 38	X
29	Reversing lamps	Directive 77/539/EEC	X
29A	Reversing lights for power-driven vehicles and their trailers	Regulation (EC) No 661/2009 UNECE Regulation No 23	X

**Status:** EU Directives are being published on this site to aid cross referencing from UK legislation. After IP completion day (31 December 2020 11pm) no further amendments will be applied to this version.

30	Parking lamps	Directive 77/540/EEC	X
30A	Parking lamps for power-driven vehicles	Regulation (EC) No 661/2009 UNECE Regulation No 77	X
31	Seat belts and restraint systems	Directive 77/541/EEC	X+W <sub>6</sub>
31A	Safety-belts, restraint systems, child restraint systems and Isofix child restraint systems	Regulation (EC) No 661/2009 UNECE Regulation No 16	X+W <sub>6</sub>
32	Forward vision	Directive 77/649/EEC	G
32A	Forward field of vision	Regulation (EC) No 661/2009 UNECE Regulation No 125	G
33	Identification of controls, tell-tales and indicators	Directive 78/316/EEC	X
33A	Location and identification of hand controls, tell-tales and indicators	Regulation (EC) No 661/2009 UNECE Regulation No 121	X
34	Defrost/demist	Directive 78/317/EEC	G <sup>(5)</sup>
34A	Windscreen defrosting and demisting systems	Regulation (EC) No 661/2009 Regulation (EU) No 672/2010	G <sup>(5)</sup>
35	Wash/wipe	Directive 78/318/EEC	G <sup>(6)</sup>
35A	Windscreen wiper and washer systems	Regulation (EC) No 661/2009 Regulation (EU) No 1008/2010	G <sup>(6)</sup>
36	Heating systems	Directive 2001/56/EC	X
36A	Heating systems	Regulation (EC) No 661/2009 UNECE Regulation No 122	X
37	Wheel guards	Directive 78/549/EEC	G

*Status: EU Directives are being published on this site to aid cross referencing from UK legislation. After IP completion day (31 December 2020 11pm) no further amendments will be applied to this version.*

37A	Wheel guards	Regulation (EC) No 661/2009 Regulation (EU) No 1009/2010	G
38	Head restraints	Directive 78/932/EEC	X
38A	Head restraints (headrests), whether or not incorporated in vehicle seats	Regulation (EC) No 661/2009 UNECE Regulation No 25	X
41	Emissions (Euro IV and V) heavy duty vehicles.	Directive 2005/55/EC	X+W <sub>1</sub> ( <sup>8</sup> )
41A	Emissions (Euro VI) heavy duty vehicles/ access to information	Regulation (EC) No 595/2009	X+W <sub>1</sub> ( <sup>9</sup> )
44	Masses and dimensions (cars)	Directive 92/21/EEC	X+W <sub>8</sub>
44A	Masses and dimensions	Regulation (EC) No 661/2009 Regulation (EU) No 1230/2012	X+W <sub>8</sub>
45	Safety glazing	Directive 92/22/EEC	G
45A	Safety glazing materials and their installation on vehicles	Regulation (EC) No 661/2009 UNECE Regulation No 43	G
46	Tyres	Directive 92/23/EEC	X
46A	Installation of tyres	Regulation (EC) No 661/2009 Regulation (EU) No 458/2011	X
46B	Pneumatic tyres for motor vehicles and their trailers (Class C1)	Regulation (EC) No 661/2009 UNECE Regulation No 30	X
46D	Tyre rolling sound emissions, adhesion on wet surfaces and rolling resistance (Classes C1, C2 and C3)	Regulation (EC) No 661/2009 UNECE Regulation No 117	X
46E	Temporary-use spare unit, run-flat tyres/ system and tyre	Regulation (EC) No 661/2009 UNECE Regulation No 64	G( <sup>9A</sup> )



**Status:** EU Directives are being published on this site to aid cross referencing from UK legislation. After IP completion day (31 December 2020 11pm) no further amendments will be applied to this version.

	pressure monitoring system		
50	Couplings	Directive 94/20/EC	X <sup>(10)</sup>
50A	Mechanical coupling components of combinations of vehicles	Regulation (EC) No 661/2009 UNECE Regulation No 55	X <sup>(10)</sup>
53	Frontal impact	Directive 96/79/EC	N/A
53A	Protection of occupants in the event of a frontal collision	Regulation (EC) No 661/2009 UNECE Regulation No 94	N/A
54	Side impact	Directive 96/27/EC	N/A
54A	Protection of occupants in the event of lateral collision	Regulation (EC) No 661/2009 UNECE Regulation No 95	N/A
58	Pedestrian protection	Regulation (EC) No 78/2009	G
59	Recyclability	Directive 2005/64/EC	N/A
61	Air-conditioning systems	Directive 2006/40/EC	G
62	Hydrogen system	Regulation (EC) No 79/2009	X
63	General Safety	Regulation (EC) No 661/2009	X <sup>(15)</sup>
64	Gear shift indicators	Regulation (EC) No 661/2009 Regulation (EU) No 65/2012	G
67	Specific components for liquefied petroleum gases (LPG) and their installation on motor vehicles	Regulation (EC) No 661/2009 UNECE Regulation No 67	X
68	Vehicle alarm systems (VAS)	Regulation (EC) No 661/2009 UNECE Regulation No 97	X
69	Electric safety	Regulation (EC) No 661/2009 UNECE Regulation No 100	X

---

*Status: EU Directives are being published on this site to aid cross referencing from UK legislation. After IP completion day (31 December 2020 11pm) no further amendments will be applied to this version.*

---

70	Specific components for CNG and their installation on motor vehicles	Regulation (EC) No 661/2009 UNECE Regulation No 110	X
----	--	--	---

### **Additional requirements for testing the wheelchair tie down and occupant restraint system**

*Note:* The following sections 1. and either section 2. or 3. shall apply.

0. Definitions
  - 0.1. Surrogate wheelchair (SWC) is a rigid, re-usable test wheelchair, as defined in section 3 of ISO 10542-1:2012.
  - 0.2. Point P is a representation of the position of the wheelchair occupant's hip when seated in the SWC, as defined in section 3 of ISO 10542-1:2012.
1. General requirements
  - 1.1. Each wheelchair location shall be provided with anchorages to which a wheelchair tie-down and occupant restraint system (WTORS) shall be fitted.
  - 1.2. The wheelchair occupant's lower belt anchorages shall be located in accordance with UNECE Regulation 14-07, paragraph 5.4.2.2, relative to Point P on the SWC when placed in the travelling position designated by the manufacturer. The upper actual anchorage (s) shall be located at least 1 100 mm above the horizontal plane passing through the points of contact between the rear tyres of the SWC and the vehicle floor. This condition shall still be satisfied after the test carried out according to paragraph 2. below.
  - 1.3. An assessment shall be made of the WTORS occupant belt to ensure compliance with the provisions of UNECE Regulation 16-06 paragraphs 8.2.2 to 8.2.2.4 and 8.3.1 to 8.3.4.
  - 1.4. The minimum number of ISOFIX child seat anchorages need not to be provided. In the case of a multi-stage approval where an ISOFIX anchorage system has been affected by the conversion, the system shall either be re-tested or the anchorages shall be rendered unusable. In the latter case the ISOFIX labels shall be removed and appropriate information given to the vehicle purchaser.
2. Static in-vehicle testing
  - 2.1. Wheelchair occupant restraint anchorages
    - 2.1.1. The wheelchair occupant restraint anchorages shall resist the static forces prescribed for occupant restraint anchorages in UNECE Regulation 14-07 simultaneously with the static forces applied to the wheelchair tie-down anchorages as specified in 2.2 below.
  - 2.2. Wheelchair tie-down anchorages

The wheelchair tie-down anchorages shall resist the following forces, for at least 0.2 seconds, applied via the SWC (or a suitable surrogate wheelchair having a wheelbase, seat height and tie-down attachment points in accordance with the specification for the SWC), at a height of 300 +/- 100 mm from the surface on which the SWC rests:

- 2.2.1. In the case of a forward-facing wheelchair, a simultaneous force, coincident with the force applied to the occupant restraint anchorages, of 24,5 kN and
- 2.2.2. a second test applying a static force of 8,2 kN directed towards the rear of the vehicle.
- 2.2.3. In the case of a rearward-facing wheelchair, a simultaneous force, coincident with the force applied to the occupant restraint anchorages, of 8,2 kN and
- 2.2.4. a second test applying a static force of 24,5 kN directed towards the front of the vehicle.
- 2.3. Components of the system
  - 2.3.1. All components of the WTORS shall meet the relevant requirements of ISO 10542-1:2012. However, the dynamic test specified in Annex A and paragraphs 5.2.2 and 5.2.3 of ISO 10542-1:2012 shall be carried out on the complete WTORS using the vehicle anchorage geometry instead of the test geometry specified in Annex A of ISO 10542-1:2012. This may be carried out within the vehicle structure or on a surrogate structure representative of the vehicle's WTORS anchorage geometry. The location of each anchorage shall lie within the tolerance provided for in point 7.7.1 of UNECE Regulation No 16-06.
  - 2.3.2. Where the occupant restraint part of the WTORS is approved according to UNECE Regulation No 16-06, it shall be subject to the dynamic test of the complete WTORS specified in paragraph 2.3.1, but the requirements of Paragraphs 5.1, 5.3 and 5.4 of ISO10542-1:2012 shall be considered to have been met.
- 3. Dynamic in-vehicle testing
  - 3.1. The full assembly of the WTORS system shall be tested by an in-vehicle dynamic test in line with paragraphs 5.2.2 and 5.2.3 and Annex A of ISO 10542-1:2012, testing all components/anchorages simultaneously, using a vehicle body-in-white or representative structure.
  - 3.2. The component parts of the WTORS shall meet the relevant requirements of ISO10542-1:2012 paragraphs 5.1, 5.3 and 5.4. These requirements shall be deemed to have been met in respect of the occupant restraint if it is approved according to UNECE Regulation No 16-06.

*Status: EU Directives are being published on this site to aid cross referencing from UK legislation. After IP completion day (31 December 2020 11pm) no further amendments will be applied to this version.*

## Appendix 4

**Other Special Purpose Vehicles (including special group, multi-equipment carrier and trailer Caravans)**

The requirements of Annex IV shall be fulfilled to the greatest extent: Application of the exemptions is only permitted if the manufacturer demonstrates to the satisfaction of the approval authority that the vehicle, due to the special function, cannot meet all the requirements.

Item	Subject	Reference to regulatory act	M <sub>2</sub>	M <sub>3</sub>	N <sub>1</sub>	N <sub>2</sub>	N <sub>3</sub>	O <sub>1</sub>	O <sub>2</sub>	O <sub>3</sub>	O <sub>4</sub>
1	Permissible sound level	Directive 70/157/EEC	H	H	H	H	H				
2	Emissions (Euro 5 and 6) light duty vehicles/ access to information	Regulation (EC) No 715/2007			Q+V <sub>1</sub> <sup>(1)</sup>	Q+V <sub>1</sub> <sup>(1)</sup>					
3	Fuel tanks/ rear protective devices	Directive 70/221/EEC	F <sup>(2)</sup>	F <sup>(2)</sup>	F <sup>(2)</sup>	F <sup>(2)</sup>	F <sup>(2)</sup>	X	X	X	X
3A	Prevention of fire risks (liquid fuel tanks)	Regulation (EC) No 661/2009 UNECE Regulation No 34		F	F	F	F	X	X	X	X
3B	Rear underrun protective devices (RUPDs) and their installation; rear underrun	Regulation (EC) No 661/2009 (RUPDs) UNECE Regulation No 58	X	X	A	A	A	X	X	X	X

**a** Any frontal protection system supplied with the vehicle shall comply with the requirements of Regulation (EC) No 78/2009 and shall be provided with a type-approval number and shall be marked accordingly.

**Status:** EU Directives are being published on this site to aid cross referencing from UK legislation. After IP completion day (31 December 2020 11pm) no further amendments will be applied to this version.

	protection (RUP)										
4	Rear registration plate space	Directive 70/222/EEC	A+R	A+R	A+R	A+R	A+R	A+R	A+R	A+R	A+R
4A	Space for mounting and fixing rear registration plates	Regulation (EC) No 661/2009 Regulation (EU) No 1003/2010	A+R	A+R	A+R	A+R	A+R	A+R	A+R	A+R	A+R
5	Steering effort	Directive 70/311/EEC	X	X	X	X	X	X	X	X	X
5A	Steering equipment	Regulation (EC) No 661/2009 UNECE Regulation No 79	X	X	X	X	X	X	X	X	X
6	Door latches and hinges	Directive 70/387/EEC		B	B	B					
6A	Vehicle access and manoeuvre	Regulation (EC) No 661/2009 Regulation (EU) No 130/2012	X	B	B	B					
6B	Door latches and door retention components	Regulation (EC) No 661/2009 UNECE Regulation No 11		B							
7	Audible warning	Directive 70/388/EEC	X	X	X	X					

**a** Any frontal protection system supplied with the vehicle shall comply with the requirements of Regulation (EC) No 78/2009 and shall be provided with a type-approval number and shall be marked accordingly.

*Status: EU Directives are being published on this site to aid cross referencing from UK legislation. After IP completion day (31 December 2020 11pm) no further amendments will be applied to this version.*

7A	Audible warning devices and signals	Regulation (EC) No 661/2009 UNECE Regulation No 28	X	X	X	X				
8	Indirect vision devices	Directive 2003/97/EC	X	X	X	X				
8A	Devices for indirect vision and their installation	Regulation (EC) No 661/2009 UNECE Regulation No 46	X	X	X	X				
9	Braking	Directive 71/320/EEC	X	X	X	X	X	X	X	X
9A	Braking of vehicles and trailers	Regulation (EC) No 661/2009 UNECE Regulation No 13	X <sup>(3)</sup>	X <sup>(3)</sup>	X+U <sub>1</sub> <sup>(3)</sup>	X+U <sub>1</sub> <sup>(3)</sup>	X	X	X <sup>(3)</sup>	X <sup>(3)</sup>
9B	Braking of passenger cars	Regulation (EC) No 661/2009 UNECE Regulation No 13-H		X <sup>(4)</sup>						
10	Radio interference (electromagnetic compatibility)	Directive 70/245/EEC	X	X	X	X	X	X	X	X
10A	Electromagnetic compatibility	Regulation (EC) No 661/2009 UNECE Regulation No 10	X	X	X	X	X	X	X	X

**a** Any frontal protection system supplied with the vehicle shall comply with the requirements of Regulation (EC) No 78/2009 and shall be provided with a type-approval number and shall be marked accordingly.

**Status:** EU Directives are being published on this site to aid cross referencing from UK legislation. After IP completion day (31 December 2020 11pm) no further amendments will be applied to this version.

13	Anti-theft and immobiliser	Directive 74/61/EEC	X	X	X	X				
13A	Protection of motor vehicles against unauthorised use	Regulation (EC) No 661/2009 against UNECE Regulation No 18	X <sup>(4A)</sup>	X <sup>(4A)</sup>		X <sup>(4A)</sup>	X <sup>(4A)</sup>			
13B	Protection of motor vehicles against unauthorised use	Regulation (EC) No 661/2009 against UNECE Regulation No 116			X					
14	Protection of steering	Directive 74/297/EEC			X					
14A	Protection of the driver against the steering mechanism in the event of impact	Regulation (EC) No 661/2009 against UNECE Regulation No 12			X					
15	Seat strength	Directive 74/408/EEC	D	D	D	D				
15A	Seats, their anchorages and any head restraint	Regulation (EC) No 661/2009 against UNECE Regulation No 17	D <sup>(4B)</sup>	D <sup>(4B)</sup>	D	D				
15B	Seats of large	Regulation (EC) No 661/2009	D							

**a** Any frontal protection system supplied with the vehicle shall comply with the requirements of Regulation (EC) No 78/2009 and shall be provided with a type-approval number and shall be marked accordingly.

*Status: EU Directives are being published on this site to aid cross referencing from UK legislation. After IP completion day (31 December 2020 11pm) no further amendments will be applied to this version.*

	passenger vehicles	UNECE Regulation No 80									
17	Speedometer and reverse gear	Directive 75/443/EEC	X	X	X	X					
17A	Vehicle access and manoeuvring	Regulation (EC) No 661/2009 Regulation (EU) No 130/2012	X	X	X	X					
17B	Speedometer equipment including its installation	Regulation (EC) No 661/2009 UNECE Regulation No 39	X	X	X	X					
18	Statutory plates	Directive 76/114/EEC	X	X	X	X	X	X	X	X	X
18A	Manufacturer's statutory plate and vehicle identification number	Regulation (EC) No 661/2009 Regulation (EU) No 19/2011	X	X	X	X	X	X	X	X	X
19	Seat belt anchorage	Directive 76/115/EEC	D	D	D	D					
19A	Safety-belt anchorage systems and Isofix top tether anchorages	Regulation (EC) No 661/2009 UNECE Regulation No 14	D	D	D	D					

**a** Any frontal protection system supplied with the vehicle shall comply with the requirements of Regulation (EC) No 78/2009 and shall be provided with a type-approval number and shall be marked accordingly.



**Status:** EU Directives are being published on this site to aid cross referencing from UK legislation. After IP completion day (31 December 2020 11pm) no further amendments will be applied to this version.

20	Installation of lighting and light signalling devices	Directive 76/756/EEC	A+N	A+N	A+N	A+N	A+N	A+N	A+N	A+N	A+N
20A	Installation of lighting and light-signalling devices on vehicles	Regulation (EC) No 661/2009 UNECE Regulation No 48	A+N	A+N	A+N	A+N	A+N	A+N	A+N	A+N	A+N
21	Retro-reflectors	Directive 76/757/EEC	X	X	X	X	X	X	X	X	X
21A	Retro-reflecting devices for power-driven vehicles and their trailers	Regulation (EC) No 661/2009 UNECE Regulation No 3	X	X	X	X	X	X	X	X	X
22	End-outline, front-position (side), rear-position (side), stop, side marker, daytime running lamps	Directive 76/758/EEC	X	X	X	X	X	X	X	X	X
22A	Front and rear position lamps,	Regulation (EC) No 661/2009	X	X	X	X	X	X	X	X	X

**a** Any frontal protection system supplied with the vehicle shall comply with the requirements of Regulation (EC) No 78/2009 and shall be provided with a type-approval number and shall be marked accordingly.

*Status: EU Directives are being published on this site to aid cross referencing from UK legislation. After IP completion day (31 December 2020 11pm) no further amendments will be applied to this version.*

	stop-lamps and end-outline marker lamps for motor vehicles and their trailers	UNECE Regulation No 7	X	X	X	X				
22B	Daytime running lamps for power-driven vehicles	Regulation (EC) No 661/2009 UNECE Regulation No 87	X	X	X	X				
22C	Side-marker lamps for motor vehicles and their trailers	Regulation (EC) No 661/2009 UNECE Regulation No 91	X	X	X	X	X	X	X	X
23	Directional indicators	Directive 76/759/EEC	X	X	X	X	X	X	X	X
23A	Directional indicators for power-driven vehicles and their trailers	Regulation (EC) No 661/2009 UNECE Regulation No 6	X	X	X	X	X	X	X	X
24	Rear registration plate lamps	Directive 76/760/EEC	X	X	X	X	X	X	X	X
24A	Illumination of rear-	Regulation (EC)	X	X	X	X	X	X	X	X

**a** Any frontal protection system supplied with the vehicle shall comply with the requirements of Regulation (EC) No 78/2009 and shall be provided with a type-approval number and shall be marked accordingly.

*Status: EU Directives are being published on this site to aid cross referencing from UK legislation. After IP completion day (31 December 2020 11pm) no further amendments will be applied to this version.*

	registration plates of power-driven vehicles and their trailers	Regulation (EC) No 661/2009 UNECE Regulation No 4									
25	Headlamps (including bulbs)	Directive 76/761/EEC	X	X	X	X					
25A	Power-driven vehicle sealed-beam headlamps (SB) emitting an European asymmetrical passing beam or a driving beam or both	Regulation (EC) No 661/2009 UNECE Regulation No 31	X	X	X	X					
25B	Filament lamps for use in approved lamp units of power-driven vehicles and their trailers	Regulation (EC) No 661/2009 UNECE Regulation No 37	X	X	X	X	X	X	X	X	X
25C	Motor vehicle headlamps equipped with	Regulation (EC) No 661/2009	X	X	X	X					

**a** Any frontal protection system supplied with the vehicle shall comply with the requirements of Regulation (EC) No 78/2009 and shall be provided with a type-approval number and shall be marked accordingly.

*Status: EU Directives are being published on this site to aid cross referencing from UK legislation. After IP completion day (31 December 2020 11pm) no further amendments will be applied to this version.*

	gas-discharge light sources	UNECE Regulation No 98									
25D	Gas-discharge light sources for use in approval of gas-discharge lamp units of power-driven vehicles	Regulation (EC) No 661/2009 UNECE Regulation No 99	X	X	X	X					
25E	Motor vehicle headlamps emitting an asymmetric passing beam or a driving beam or both and equipped with filament lamps and/or LED modules	Regulation (EC) No 661/2009 UNECE Regulation No 112	X	X	X	X					
25F	Adaptive front-lighting systems (AFS) for motor vehicles	Regulation (EC) No 661/2009 UNECE Regulation No 123	X	X	X	X					

**a** Any frontal protection system supplied with the vehicle shall comply with the requirements of Regulation (EC) No 78/2009 and shall be provided with a type-approval number and shall be marked accordingly.

**Status:** EU Directives are being published on this site to aid cross referencing from UK legislation. After IP completion day (31 December 2020 11pm) no further amendments will be applied to this version.

26	Front fog lamps	Directive 76/762/EEC	X	X	X	X				
26A	Power-driven vehicle front fog lamps	Regulation (EC) No 661/2009 UNECE Regulation No 19	X	X	X	X				
27	Towing hooks	Directive 77/389/EEC	A	A	A	A				
27A	Towing device	Regulation (EC) No 661/2009 Regulation (EU) No 1005/2010	A	A	A	A				
28	Rear fog lamps	Directive 77/538/EEC	X	X	X	X	X	X	X	X
28A	Rear fog lamps for power-driven vehicles and their trailers	Regulation (EC) No 661/2009 UNECE Regulation No 38	X	X	X	X	X	X	X	X
29	Reversing lamps	Directive 77/539/EEC	X	X	X	X	X	X	X	X
29A	Reversing lights for power-driven vehicles and their trailers	Regulation (EC) No 661/2009 UNECE Regulation No 23	X	X	X	X	X	X	X	X

**a** Any frontal protection system supplied with the vehicle shall comply with the requirements of Regulation (EC) No 78/2009 and shall be provided with a type-approval number and shall be marked accordingly.

*Status: EU Directives are being published on this site to aid cross referencing from UK legislation. After IP completion day (31 December 2020 11pm) no further amendments will be applied to this version.*

30	Parking lamps	Directive 77/540/EEC	X	X	X	X				
30A	Parking lamps for power-driven vehicles	Regulation (EC) No 661/2009 UNECE Regulation No 77	X	X	X	X				
31	Seat belts and restraint systems	Directive 77/541/EEC	D	D	D	D				
31A	Safety-belts, restraint systems child restraint systems and Isofix child restraint systems	Regulation (EC) No 661/2009 UNECE Regulation No 16	D	D	D	D				
33	Identification of controls tell-tales and indicators	Directive 78/316/EEC	X	X	X	X				
33A	Location and identification of hand controls tell-tales and indicators	Regulation (EC) No 661/2009 UNECE Regulation No 121	X	X	X	X				
34	Defrost demist	Directive 78/317/EEC	(5)	(5)	(5)	(5)				

**a** Any frontal protection system supplied with the vehicle shall comply with the requirements of Regulation (EC) No 78/2009 and shall be provided with a type-approval number and shall be marked accordingly.

**Status:** EU Directives are being published on this site to aid cross referencing from UK legislation. After IP completion day (31 December 2020 11pm) no further amendments will be applied to this version.

34A	Windscreen defrosting and demisting systems	Regulation (EC) No 661/2009 Regulation (EU) No 672/2010	( <sup>5</sup> )	( <sup>5</sup> )	( <sup>5</sup> )	( <sup>5</sup> )				
35	Wash/wipe	Directive 78/318/EEC	( <sup>6</sup> )	( <sup>6</sup> )	( <sup>6</sup> )	( <sup>6</sup> )				
35A	Windscreen wiper and washer systems	Regulation (EC) No 661/2009 Regulation (EU) No 1008/2010	( <sup>6</sup> )	( <sup>6</sup> )	( <sup>6</sup> )	( <sup>6</sup> )				
36	Heating systems	Directive 2001/56/EC	X	X	X	X	X	X	X	X
36A	Heating systems	Regulation (EC) No 661/2009 UNECE Regulation No 122	X	X	X	X	X	X	X	X
38A	Head restraint (headrest), whether or not incorporated in vehicle seats	Regulation (EC) No 661/2009 UNECE Regulation No 25	X							
41	Emission (Euro IV and V) heavy duty vehicles.	Directive 2005/55/EC	H ( <sup>8</sup> )	H ( <sup>8</sup> )	H ( <sup>8</sup> )	H				

**a** Any frontal protection system supplied with the vehicle shall comply with the requirements of Regulation (EC) No 78/2009 and shall be provided with a type-approval number and shall be marked accordingly.

*Status: EU Directives are being published on this site to aid cross referencing from UK legislation. After IP completion day (31 December 2020 11pm) no further amendments will be applied to this version.*

41A	Emission (Euro VI) heavy duty vehicles/ access to information	Regulation (EC) No 595/2009	H <sup>(9)</sup>	H	H <sup>(9)</sup>	H <sup>(9)</sup>	H				
42	Lateral protection	Directive 89/297/EEC				X	X			X	X
42A	Lateral protection of goods vehicles	Regulation (EC) No 661/2009 UNECE Regulation No 73				X	X			X	X
43	Spray-suppression systems	Directive 91/226/EEC		X	X	X	X	X	X	X	X
43A	Spray suppression systems	Regulation (EC) No 661/2009 Regulation (EU) No 109/2011		X	X	X	X	X	X	X	X
45	Safety glazing	Directive 92/22/EEC	J	J	J	J	J	J	J	J	J
45A	Safety glazing material and their installation on vehicles	Regulation (EC) No 661/2009 UNECE Regulation No 43	J	J	J	J	J	J	J	J	J
46	Tyres	Directive 92/23/EEC	X	X	X	X	X	X	X	X	X

**a** Any frontal protection system supplied with the vehicle shall comply with the requirements of Regulation (EC) No 78/2009 and shall be provided with a type-approval number and shall be marked accordingly.



*Status: EU Directives are being published on this site to aid cross referencing from UK legislation. After IP completion day (31 December 2020 11pm) no further amendments will be applied to this version.*

46A	Installation of tyres	Regulation (EC) No 661/2009 Regulation (EU) No 458/2011	X	X	X	X	X	X	X	X
46B	Pneumatic tyres for motor vehicles and their trailers (Class C1)	Regulation (EC) No 661/2009 UNECE Regulation No 30		X			X	X		
46C	Pneumatic tyres for commercial vehicles and their trailers (Classes C2 and C3)	Regulation (EC) No 661/2009 UNECE Regulation No 54	X	X	X	X			X	X
46D	Tyre rolling sound emissions, adhesion on wet surfaces and rolling resistance (Classes C1, C2 and C3)	Regulation (EC) No 661/2009 UNECE Regulation No 117	X	X	X	X	X	X	X	X
46E	Temporary use	Regulation (EC)		X <sup>(9A)</sup>						

**a** Any frontal protection system supplied with the vehicle shall comply with the requirements of Regulation (EC) No 78/2009 and shall be provided with a type-approval number and shall be marked accordingly.

*Status: EU Directives are being published on this site to aid cross referencing from UK legislation. After IP completion day (31 December 2020 11pm) no further amendments will be applied to this version.*

	spare unit, run-flat tyres/ system and tyre pressure monitoring system	No 661/2009 UNECE Regulation No 64									
47	Speed limitation devices	Directive 92/24/EEC	X		X	X					
47A	Speed limitation of vehicles	Regulation (EC) No 661/2009 UNECE Regulation No 89	X		X	X					
48	Masses and dimensions (other than vehicles referred to in item 44)	Directive 97/27/EC	X	X	X	X	X	X	X	X	X
48A	Masses and dimensions	Regulation (EC) No 661/2009 Regulation (EU) No 1230/2012	X	X	X	X	X	X	X	X	X
49	External projections of cabs	Directive 92/114/EEC		X	X	X					
49A	Commercial vehicles with regard to	Regulation (EC) No 661/2009		X	X	X					

**a** Any frontal protection system supplied with the vehicle shall comply with the requirements of Regulation (EC) No 78/2009 and shall be provided with a type-approval number and shall be marked accordingly.

*Status: EU Directives are being published on this site to aid cross referencing from UK legislation. After IP completion day (31 December 2020 11pm) no further amendments will be applied to this version.*

	their external projection forward of the cab's rear panel	UNECE Regulation No 61									
50	Coupling	Directive 94/20/EC	X <sup>(10)</sup>	X <sup>(10)</sup>	X <sup>(10)</sup>	X <sup>(10)</sup>	X <sup>(10)</sup>	X	X	X	X
50A	Mechanical coupling components of combination of vehicles	Regulation (EC) No 661/2009 UNECE Regulation No 55	X <sup>(10)</sup>	X <sup>(10)</sup>	X <sup>(10)</sup>	X <sup>(10)</sup>	X <sup>(10)</sup>	X	X	X	X
50B	Close-coupling device (CCD) fitting of an approved type of CCD	Regulation (EC) No 661/2009 UNECE Regulation No 102				X <sup>(10)</sup>	X <sup>(10)</sup>			X <sup>(10)</sup>	X <sup>(10)</sup>
51	Flammable	Directive 95/28/EC	X								
51A	Burning behavior of materials used in the interior construction of certain categories of motor vehicles	Regulation (EC) No 661/2009 UNECE Regulation No 10	X								

**a** Any frontal protection system supplied with the vehicle shall comply with the requirements of Regulation (EC) No 78/2009 and shall be provided with a type-approval number and shall be marked accordingly.

*Status: EU Directives are being published on this site to aid cross referencing from UK legislation. After IP completion day (31 December 2020 11pm) no further amendments will be applied to this version.*

52	Buses and coaches	Directive 2001/85/EC	X								
52A	M <sub>2</sub> and M <sub>3</sub> vehicles	Regulation (EC) No 661/2009 UNECE Regulation No 107	X								
52B	Strengthening of the superstructure of large passenger vehicles	Regulation (EC) No 661/2009 UNECE Regulation No 66	X								
54	Side impact	Directive 96/27/EC		A							
54A	Protection of occupants in the event of lateral collision	Regulation (EC) No 661/2009 UNECE Regulation No 95		A							
56	Vehicles intended for the transport of dangerous goods	Directive 2008/91/EC			X <sup>(13)</sup>	X <sup>(13)</sup>	X <sup>(13)</sup>	X <sup>(13)</sup>	X <sup>(13)</sup>	X <sup>(13)</sup>	X <sup>(13)</sup>
56A	Vehicles for the carriage of dangerous goods	Regulation (EC) No 661/2009 UNECE Regulation No 105			X <sup>(13)</sup>	X <sup>(13)</sup>	X <sup>(13)</sup>	X <sup>(13)</sup>	X <sup>(13)</sup>	X <sup>(13)</sup>	X <sup>(13)</sup>

**a** Any frontal protection system supplied with the vehicle shall comply with the requirements of Regulation (EC) No 78/2009 and shall be provided with a type-approval number and shall be marked accordingly.

**Status:** EU Directives are being published on this site to aid cross referencing from UK legislation. After IP completion day (31 December 2020 11pm) no further amendments will be applied to this version.

57	Front underrun protection (FUP)	Directive 2000/40/EC			X	X				
57A	Front underrun protective devices (FUPDs) and their installation; front underrun protection (FUP)	Regulation (EC) No 661/2009 (UNECE Regulation No 93)			X	X				
58	Pedestrian protection	Regulation (EC) No 78/2009		N/A <sup>a</sup>						
59	Recycling	Directive 2005/64/EC		N/A		—				
61	Air-conditioning systems	Directive 2006/40/EC		X <sup>(14)</sup>						
62	Hydrogen system	Regulation (EC) No 79/2009	X	X	X	X				
63	General Safety	Regulation (EC) No 661/2009	X <sup>(15)</sup>	X <sup>(15)</sup>	X <sup>(15)</sup>	X <sup>(15)</sup>	X <sup>(15)</sup>	X <sup>(15)</sup>	X <sup>(15)</sup>	X <sup>(15)</sup>
65	Advanced emergency braking system	Regulation (EC) No 661/2009 Regulation (EU) No 347/2012	N/A	N/A	N/A	N/A				
66	Lane departure warning system	Regulation (EC) No 661/2009	N/A	N/A	N/A	N/A				

<sup>a</sup> Any frontal protection system supplied with the vehicle shall comply with the requirements of Regulation (EC) No 78/2009 and shall be provided with a type-approval number and shall be marked accordingly.

*Status: EU Directives are being published on this site to aid cross referencing from UK legislation. After IP completion day (31 December 2020 11pm) no further amendments will be applied to this version.*

		Regulation (EU) No 351/2012								
67	Specific component for liquefied petroleum gases (LPG) and their installation on motor vehicles	Regulation (EC) No 661/2009 UNECE Regulation No 67	X	X	X	X				
68	Vehicle alarm systems (VAS)	Regulation (EC) No 661/2009 UNECE Regulation No 97		X						
69	Electric safety	Regulation (EC) No 661/2009 UNECE Regulation No 100	X	X	X	X				
70	Specific component for CNG and their installation on motor vehicles	Regulation (EC) No 661/2009 UNECE Regulation No 110	X	X	X	X				

**a** Any frontal protection system supplied with the vehicle shall comply with the requirements of Regulation (EC) No 78/2009 and shall be provided with a type-approval number and shall be marked accordingly.

*Status: EU Directives are being published on this site to aid cross referencing from UK legislation. After IP completion day (31 December 2020 11pm) no further amendments will be applied to this version.*

## Appendix 5

## Mobile Cranes

Item	Subject	Reference to regulatory act	N <sub>3</sub>
1	Permissible sound level	Directive 70/157/EEC	T+Z <sub>1</sub>
3	Fuel tanks/rear protective devices	Directive 70/221/EEC	X <sup>(2)</sup>
3A	Prevention of fire risks (liquid fuel tanks)	Regulation (EC) No 661/2009 UNECE Regulation No 34	X
3B	Rear underrun protective devices (RUPDs) and their installation; rear underrun protection (RUP)	Regulation (EC) No 661/2009 UNECE Regulation No 58	A
4	Rear registration plate space	Directive 70/222/EEC	X
4A	Space for mounting and fixing rear registration plates	Regulation (EC) No 661/2009 Regulation (EU) No 1003/2010	X
5	Steering effort	Directive 70/311/EEC	X Crab steering allowed
5A	Steering equipment	Regulation (EC) No 661/2009 UNECE Regulation No 79	X Crab steering allowed
6	Door latches and hinges	Directive 70/387/EEC	A
6A	Vehicle access and manoeuvrability	Regulation (EC) No 661/2009 Regulation (EU) No 130/2012	A
7	Audible warning	Directive 70/388/EEC	X
7A	Audible warning devices and signals	Regulation (EC) No 661/2009 UNECE Regulation No 28	X
8	Indirect vision devices	Directive 2003/97/EC	A

*Status: EU Directives are being published on this site to aid cross referencing from UK legislation. After IP completion day (31 December 2020 11pm) no further amendments will be applied to this version.*

8A	Devices for indirect vision and their installation	Regulation (EC) No 661/2009 UNECE Regulation No 46	X
9	Braking	Directive 71/320/EEC	U
9A	Braking of vehicles and trailers	Regulation (EC) No 661/2009 UNECE Regulation No 13	U <sup>(3)</sup>
10	Radio interference (electromagnetic compatibility)	Directive 72/245/EEC	X
10A	Electromagnetic compatibility	Regulation (EC) No 661/2009 UNECE Regulation No 10	X
13	Anti-theft and immobiliser	Directive 74/61/EEC	X
13A	Protection of motor vehicles against unauthorised use	Regulation (EC) No 661/2009 UNECE Regulation No 18	X <sup>(4A)</sup>
15	Seat strength	Directive 74/408/EEC	D
15A	Seats, their anchorages and any head restraints	Regulation (EC) No 661/2009 UNECE Regulation No 17	X
17	Speedometer and reverse gear	Directive 75/443/EEC	X
17A	Vehicle access and manoeuvrability	Regulation (EC) No 661/2009 Regulation (EU) No 130/2012	X
17B	Speedometer equipment including its installation	Regulation (EC) No 661/2009 UNECE Regulation No 39	X
18	Statutory plates	Directive 76/114/EEC	X
18A	Manufacturer's statutory plate and vehicle identification number	Regulation (EC) No 661/2009 Regulation (EU) No 19/2011	X



*Status: EU Directives are being published on this site to aid cross referencing from UK legislation. After IP completion day (31 December 2020 11pm) no further amendments will be applied to this version.*

19	Seat belt anchorages	Directive 76/115/EEC	D
19A	Safety-belt anchorages, Isofix anchorages systems and Isofix top tether anchorages	Regulation (EC) No 661/2009 UNECE Regulation No 14	X
20	Installation of lighting and light signalling devices	Directive 76/756/EEC	A+Y
20A	Installation of lighting and light-signalling devices on vehicles	Regulation (EC) No 661/2009 UNECE Regulation No 48	A+Y
21	Retro reflectors	Directive 76/757/EEC	X
21A	Retro-reflecting devices for power-driven vehicles and their trailers	Regulation (EC) No 661/2009 UNECE Regulation No 3	X
22	End-outline, front-position (side), rear-position (side), stop, side marker, daytime running lamps	Directive 76/758/EEC	X
22A	Front and rear position lamps, stop-lamps and end-outline marker lamps for motor vehicles and their trailers	Regulation (EC) No 661/2009 UNECE Regulation No 7	X
22B	Daytime running lamps for power-driven vehicles	Regulation (EC) No 661/2009 UNECE Regulation No 87	X
22C	Side-marker lamps for motor vehicles and their trailers	Regulation (EC) No 661/2009 UNECE Regulation No 91	X
23	Direction indicators	Directive 76/759/EEC	X
23A	Direction indicators for power-driven vehicles and their trailers	Regulation (EC) No 661/2009 UNECE Regulation No 6	X

*Status: EU Directives are being published on this site to aid cross referencing from UK legislation. After IP completion day (31 December 2020 11pm) no further amendments will be applied to this version.*

24	Rear registration plate lamps	Directive 76/760/EEC	X
24A	Illumination of rear-registration plates of power-driven vehicles and their trailers	Regulation (EC) No 661/2009 UNECE Regulation No 4	X
25	Headlamps (including bulbs)	Directive 76/761/EEC	X
25A	Power-driven vehicle's sealed-beam headlamps (SB) emitting an European asymmetrical passing beam or a driving beam or both	Regulation (EC) No 661/2009 UNECE Regulation No 31	X
25B	Filament lamps for use in approved lamp units of power-driven vehicles and their trailers	Regulation (EC) No 661/2009 UNECE Regulation No 37	X
25C	Motor vehicle headlamps equipped with gas-discharge light sources	Regulation (EC) No 661/2009 UNECE Regulation No 98	X
25D	Gas-discharge light sources for use in approved gas-discharge lamp units of power-driven vehicles	Regulation (EC) No 661/2009 UNECE Regulation No 99	X
25E	Motor vehicle headlamps emitting an asymmetrical passing beam or a driving beam or both and equipped with filament lamps and/or LED modules	Regulation (EC) No 661/2009 UNECE Regulation No 112	X
25F	Adaptive front-lighting systems (AFS) for motor vehicles	Regulation (EC) No 661/2009 UNECE Regulation No 123	X
26	Front fog lamps	Directive 76/762/EEC	X
26A	Power-driven vehicle front fog lamps	Regulation (EC) No 661/2009	X

**Status:** EU Directives are being published on this site to aid cross referencing from UK legislation. After IP completion day (31 December 2020 11pm) no further amendments will be applied to this version.

		UNECE Regulation No 19	
27	Towing hooks	Directive 77/389/EEC	A
27A	Towing device	Regulation (EC) No 661/2009 Regulation (EU) No 1005/2010	A
28	Rear fog lamps	Directive 77/538/EEC	X
28A	Rear fog lamps for power-driven vehicles and their trailers	Regulation (EC) No 661/2009 UNECE Regulation No 38	X
29	Reversing lamps	Directive 77/539/EEC	X
29A	Reversing lights for power-driven vehicles and their trailers	Regulation (EC) No 661/2009 UNECE Regulation No 23	X
30	Parking lamps	Directive 77/540/EEC	X
30A	Parking lamps for power-driven vehicles	Regulation (EC) No 661/2009 UNECE Regulation No 77	X
31	Seat belts and restraint systems	Directive 77/541/EEC	D
31A	Safety-belts, restraint systems, child restraint systems and Isofix child restraint systems	Regulation (EC) No 661/2009 UNECE Regulation No 16	X
33	Identification of controls, tell-tales and indicators	Directive 78/316/EEC	X
33A	Location and identification of hand controls, tell-tales and indicators	Regulation (EC) No 661/2009 UNECE Regulation No 121	X
34	Defrost/demist	Directive 78/317/EEC	( <sup>5</sup> )
34A	Windscreen defrosting and demisting systems	Regulation (EC) No 661/2009	( <sup>5</sup> )

*Status: EU Directives are being published on this site to aid cross referencing from UK legislation. After IP completion day (31 December 2020 11pm) no further amendments will be applied to this version.*

		Regulation (EU) No 672/2010	
35	Wash/wipe	Directive 78/318/EEC	( <sup>6</sup> )
35A	Windscreen wiper and washer systems	Regulation (EC) No 661/2009 Regulation (EU) No 1008/2010	( <sup>6</sup> )
36	Heating systems	Directive 2001/56/EC	X
36A	Heating systems	Regulation (EC) No 661/2009 UNECE Regulation No 122	X
41	Emissions (Euro IV and V) heavy duty vehicles.	Directive 2005/55/EC	V
41A	Emissions (Euro VI) heavy duty vehicles/ access to information	Regulation (EC) No 595/2009	V
42	Lateral protection	Directive 89/297/EEC	X
42A	Lateral protection of goods vehicles	Regulation (EC) No 661/2009 UNECE Regulation No 73	A
43	Spray-suppression systems	Directive 91/226/EEC	X
43A	Spray suppression systems	Regulation (EC) No 661/2009 Regulation (EU) No 109/2011	Z <sub>1</sub>
45	Safety glazing	Directive 92/22/EEC	J
45A	Safety glazing materials and their installation on vehicles	Regulation (EC) No 661/2009 UNECE Regulation No 43	J
46	Tyres	Directive 92/23/EEC	X
46A	Installation of tyres	Regulation (EC) No 661/2009 Regulation (EU) No 458/2011	X
46C	Pneumatic tyres for commercial vehicles	Regulation (EC) No 661/2009	X

**Status:** EU Directives are being published on this site to aid cross referencing from UK legislation. After IP completion day (31 December 2020 11pm) no further amendments will be applied to this version.

	and their trailers (Classes C2 and C3)	UNECE Regulation No 54	
46D	Tyre rolling sound emissions, adhesion on wet surfaces and rolling resistance (Classes C1, C2 and C3)	Regulation (EC) No 661/2009 UNECE Regulation No 117	X
47	Speed limitation devices	Directive 92/24/EEC	X
47A	Speed limitation of vehicles	Regulation (EC) No 661/2009 UNECE Regulation No 89	X
48	Masses and dimensions (other than vehicles referred to in item 44)	Directive 97/27/EC	X
48A	Masses and dimensions	Regulation (EC) No 661/2009 Regulation (EU) No 1230/2012	A
49	External projections of cabs	Directive 92/114/EEC	X
49A	Commercial vehicles with regard to their external projections forward of the cab's rear panel	Regulation (EC) No 661/2009 UNECE Regulation No 61	A
50	Couplings	Directive 94/20/EC	X <sup>(10)</sup>
50A	Mechanical coupling components of combinations of vehicles	Regulation (EC) No 661/2009 UNECE Regulation No 55	X <sup>(10)</sup>
50B	Close-coupling device (CCD); fitting of an approved type of CCD	Regulation (EC) No 661/2009 UNECE Regulation No 102	X <sup>(10)</sup>
57	Front underrun protection	Directive 2000/40/EC	Z <sub>1</sub>
57A	Front underrun protective devices (FUPDs) and their installation; front underrun protection (FUP)	Regulation (EC) No 661/2009 UNECE Regulation No 93	X

---

*Status: EU Directives are being published on this site to aid cross referencing from UK legislation. After IP completion day (31 December 2020 11pm) no further amendments will be applied to this version.*

---

62	Hydrogen system	Regulation (EC) No 79/2009	X
63	General Safety	Regulation (EC) No 661/2009	X <sup>(15)</sup>
65	Advanced emergency braking system	Regulation (EC) No 661/2009 Regulation (EU) No 347/2012	N/A <sup>(16)</sup>
66	Lane departure warning system	Regulation (EC) No 661/2009 Regulation (EU) No 351/2012	N/A <sup>(17)</sup>
67	Specific components for liquefied petroleum gases (LPG) and their installation on motor vehicles	Regulation (EC) No 661/2009 UNECE Regulation No 67	X
69	Electric safety	Regulation (EC) No 661/2009 UNECE Regulation No 100	X
70	Specific components for CNG and their installation on motor vehicles	Regulation (EC) No 661/2009 UNECE Regulation No 110	X

*Status: EU Directives are being published on this site to aid cross referencing from UK legislation. After IP completion day (31 December 2020 11pm) no further amendments will be applied to this version.*

## Appendix 6

**Exceptional load transport vehicles**

<b>Item</b>	<b>Subject</b>	<b>Reference to regulatory act</b>	<b>N<sub>3</sub></b>	<b>O<sub>4</sub></b>
1	Permissible sound level	Directive 70/157/EEC	T	
3	Fuel tanks/rear protective devices	Directive 70/221/EEC	X <sup>(2)</sup>	X
3A	Prevention of fire risks (liquid fuel tanks)	Regulation (EC) No 661/2009 UNECE Regulation No 34	X	X
3B	Rear underrun protective devices (RUPDs) and their installation; rear underrun protection (RUP)	Regulation (EC) No 661/2009 UNECE Regulation No 58	A	A
4	Rear registration plate space	Directive 70/222/EEC	X	A+R
4A	Space for mounting and fixing rear registration plates	Regulation (EC) No 661/2009 Regulation (EU) No 1003/2010	X	A+R
5	Steering effort	Directive 70/311/EEC	X Crab steering allowed	X
5A	Steering equipment	Regulation (EC) No 661/2009 UNECE Regulation No 79	X Crab steering allowed	X
6	Door latches and hinges	Directive 70/387/EEC	X	
6A	Vehicle access and manoeuvrability	Regulation (EC) No 661/2009 Regulation (EU) No 130/2012	X	
7	Audible warning	Directive 70/388/EEC	X	

*Status: EU Directives are being published on this site to aid cross referencing from UK legislation. After IP completion day (31 December 2020 11pm) no further amendments will be applied to this version.*

7A	Audible warning devices and signals	Regulation (EC) No 661/2009 UNECE Regulation No 28	X	
8	Indirect vision devices	Directive 2003/97/EC	X	
8A	Devices for indirect vision and their installation	Regulation (EC) No 661/2009 UNECE Regulation No 46	X	
9	Braking	Directive 71/320/EEC	U	X
9A	Braking of vehicles and trailers	Regulation (EC) No 661/2009 UNECE Regulation No 13	U <sup>(3)</sup>	X <sup>(3)</sup>
10	Radio interference (electromagnetic compatibility)	Directive 72/245/EEC	X	X
10A	Electromagnetic compatibility	Regulation (EC) No 661/2009 UNECE Regulation No 10	X	X
13	Anti-theft and immobiliser	Directive 74/61/EEC	X	
13A	Protection of motor vehicles against unauthorised use	Regulation (EC) No 661/2009 UNECE Regulation No 18	X <sup>(4A)</sup>	
15	Seat strength	Directive 74/408/EEC	X	
15A	Seats, their anchorages and any head restraints	Regulation (EC) No 661/2009 UNECE Regulation No 17	X	
17	Speedometer and reverse gear	Directive 75/443/EEC	X	



*Status: EU Directives are being published on this site to aid cross referencing from UK legislation. After IP completion day (31 December 2020 11pm) no further amendments will be applied to this version.*

17A	Vehicle access and manoeuvrability	Regulation (EC) No 661/2009 Regulation (EU) No 130/2012	X	
17B	Speedometer equipment including its installation	Regulation (EC) No 661/2009 UNECE Regulation No 39	X	
18	Statutory plates	Directive 76/114/EEC	X	X
18A	Manufacturer's statutory plate and vehicle identification number	Regulation (EC) No 661/2009 Regulation (EU) No 19/2011	X	X
19	Seat belt anchorages	Directive 76/115/EEC	X	
19A	Safety-belt anchorages, Isofix anchorages systems and Isofix top tether anchorages	Regulation (EC) No 661/2009 UNECE Regulation No 14	X	
20	Installation of lighting and light signalling devices	Directive 76/756/EEC	X	A+N
20A	Installation of lighting and light-signalling devices on vehicles	Regulation (EC) No 661/2009 UNECE Regulation No 48	X	A+N
21	Retro reflectors	Directive 76/757/EEC	X	X
21A	Retro-reflecting devices for power-driven vehicles and their trailers	Regulation (EC) No 661/2009 UNECE Regulation No 3	X	X
22	End-outline, front-position (side), rear-position (side), stop, side	Directive 76/758/EEC	X	X

*Status: EU Directives are being published on this site to aid cross referencing from UK legislation. After IP completion day (31 December 2020 11pm) no further amendments will be applied to this version.*

	marker, daytime running lamps			
22A	Front and rear position lamps, stop-lamps and end-ouline marker lamps for motor vehicles and their trailers	Regulation (EC) No 661/2009 UNECE Regulation No 7	X	X
22B	Daytime running lamps for power-driven vehicles	Regulation (EC) No 661/2009 UNECE Regulation No 87	X	
22C	Side-marker lamps for motor vehicles and their trailers	Regulation (EC) No 661/2009 UNECE Regulation No 91	X	X
23	Direction indicators	Directive 76/759/EEC	X	X
23A	Direction indicators for power-driven vehicles and their trailers	Regulation (EC) No 661/2009 UNECE Regulation No 6	X	X
24	Rear registration plate lamps	Directive 76/760/EEC	X	X
24A	Illumination of rear-registration plates of power-driven vehicles and their trailers	Regulation (EC) No 661/2009 UNECE Regulation No 4	X	X
25	Headlamps (including bulbs)	Directive 76/761/EEC	X	
25A	Power-driven vehicle's sealed-beam headlamps (SB) emitting an European asymmetrical passing beam or a driving beam or both	Regulation (EC) No 661/2009 UNECE Regulation No 31	X	
25B	Filament lamps for use in approved lamp	Regulation (EC) No 661/2009	X	X

**Status:** EU Directives are being published on this site to aid cross referencing from UK legislation. After IP completion day (31 December 2020 11pm) no further amendments will be applied to this version.

	units of power-driven vehicles and their trailers	UNECE Regulation No 37		
25C	Motor vehicle headlamps equipped with gas-discharge light sources	Regulation (EC) No 661/2009 UNECE Regulation No 98	X	
25D	Gas-discharge light sources for use in approved gas-discharge lamp units of power-driven vehicles	Regulation (EC) No 661/2009 UNECE Regulation No 99	X	
25E	Motor vehicle headlamps emitting an asymmetrical passing beam or a driving beam or both and equipped with filament lamps and/or LED modules	Regulation (EC) No 661/2009 UNECE Regulation No 112	X	
25F	Adaptive front-lighting systems (AFS) for motor vehicles	Regulation (EC) No 661/2009 UNECE Regulation No 123	X	
26	Front fog lamps	Directive 76/762/EEC	X	
26A	Power-driven vehicle front fog lamps	Regulation (EC) No 661/2009 UNECE Regulation No 19	X	
27	Towing hooks	Directive 77/389/EEC	A	
27A	Towing device	Regulation (EC) No 661/2009 Regulation (EU) No 1005/2010	A	
28	Rear fog lamps	Directive 77/538/EEC	X	X

*Status: EU Directives are being published on this site to aid cross referencing from UK legislation. After IP completion day (31 December 2020 11pm) no further amendments will be applied to this version.*

28A	Rear fog lamps for power-driven vehicles and their trailers	Regulation (EC) No 661/2009 UNECE Regulation No 38	X	X
29	Reversing lamps	Directive 77/539/EEC	X	X
29A	Reversing lights for power-driven vehicles and their trailers	Regulation (EC) No 661/2009 UNECE Regulation No 23	X	X
30	Parking lamps	Directive 77/540/EEC	X	
30A	Parking lamps for power-driven vehicles	Regulation (EC) No 661/2009 UNECE Regulation No 77	X	
31	Seat belts and restraint systems	Directive 77/541/EEC	X	
31A	Safety-belts, restraint systems, child restraint systems and Isofix child restraint systems	Regulation (EC) No 661/2009 UNECE Regulation No 16	X	
33	Identification of controls, tell-tales and indicators	Directive 78/316/EEC	X	
33A	Location and identification of hand controls, tell-tales and indicators	Regulation (EC) No 661/2009 UNECE Regulation No 121	X	
34	Defrost/demist	Directive 78/317/EEC	( <sup>5</sup> )	
34A	Windscreen defrosting and demisting systems	Regulation (EC) No 661/2009 Regulation (EU) No 672/2010	( <sup>5</sup> )	
35	Wash/wipe	Directive 78/318/EEC	( <sup>6</sup> )	

**Status:** EU Directives are being published on this site to aid cross referencing from UK legislation. After IP completion day (31 December 2020 11pm) no further amendments will be applied to this version.

35A	Windscreen wiper and washer systems	Regulation (EC) No 661/2009 Regulation (EU) No 1008/2010	( <sup>6</sup> )	
36	Heating systems	Directive 2001/56/EC	X	
36A	Heating systems	Regulation (EC) No 661/2009 UNECE Regulation No 122	X	
41	Emissions (Euro IV and V) heavy duty vehicles.	Directive 2005/55/EC	X ( <sup>8</sup> )	
41A	Emissions (Euro VI) heavy duty vehicles/access to information	Regulation (EC) No 595/2009	X ( <sup>9</sup> )	
42	Lateral protection	Directive 89/297/EEC	X	A
42A	Lateral protection of goods vehicles	Regulation (EC) No 661/2009 UNECE Regulation No 73	X	A
43	Spray-suppression systems	Directive 91/226/EEC	X	A
43A	Spray suppression systems	Regulation (EC) No 661/2009 Regulation (EU) No 109/2011	X	A
45	Safety glazing	Directive 92/22/EEC	X	
45A	Safety glazing materials and their installation on vehicles	Regulation (EC) No 661/2009 UNECE Regulation No 43	X	
46	Tyres	Directive 92/23/EEC	X	I
46A	Installation of tyres	Regulation (EC) No 661/2009 Regulation (EU) No 458/2011	X	I

*Status: EU Directives are being published on this site to aid cross referencing from UK legislation. After IP completion day (31 December 2020 11pm) no further amendments will be applied to this version.*

46C	Pneumatic tyres for commercial vehicles and their trailers (Classes C2 and C3)	Regulation (EC) No 661/2009 UNECE Regulation No 54	X	I
46D	Tyre rolling sound emissions, adhesion on wet surfaces and rolling resistance (Classes C1, C2 and C3)	Regulation (EC) No 661/2009 UNECE Regulation No 117	X	I
47	Speed limitation devices	Directive 92/24/EEC	X	
47A	Speed limitation of vehicles	Regulation (EC) No 661/2009 UNECE Regulation No 89	X	
48	Masses and dimensions (other than vehicles referred to in item 44)	Directive 97/27/EC	X	X
48A	Masses and dimensions	Regulation (EC) No 661/2009 Regulation (EU) No 1230/2012	A	A
49	External projections of cabs	Directive 92/114/EEC	A	
49A	Commercial vehicles with regard to their external projections forward of the cab's rear panel	Regulation (EC) No 661/2009 UNECE Regulation No 61	A	
50	Couplings	Directive 94/20/EC	X <sup>(10)</sup>	X
50A	Mechanical coupling components of combinations of vehicles	Regulation (EC) No 661/2009 UNECE Regulation No 55	X <sup>(10)</sup>	X

**Status:** EU Directives are being published on this site to aid cross referencing from UK legislation. After IP completion day (31 December 2020 11pm) no further amendments will be applied to this version.

50B	Close-coupling device (CCD); fitting of an approved type of CCD	Regulation (EC) No 661/2009 UNECE Regulation No 102	X <sup>(10)</sup>	X <sup>(10)</sup>
56	Vehicles intended for the transport of dangerous goods	Directive 98/91/EC	X <sup>(13)</sup>	X <sup>(13)</sup>
56A	Vehicles for the carriage of dangerous goods	Regulation (EC) No 661/2009 UNECE Regulation No 105	X <sup>(13)</sup>	X <sup>(13)</sup>
57	Front underrun protection	Directive 2000/40/EC	A	
57A	Front underrun protective devices (FUPDs) and their installation; front underrun protection (FUP)	Regulation (EC) No 661/2009 UNECE Regulation No 93	A	
62	Hydrogen system	Regulation (EC) No 79/2009	X	
63	General Safety	Regulation (EC) No 661/2009	X <sup>(15)</sup>	X <sup>(15)</sup>
65	Advanced emergency braking system	Regulation (EC) No 661/2009 Regulation (EU) No 347/2012	N/A <sup>(16)</sup>	
66	Lane departure warning system	Regulation (EC) No 661/2009 Regulation (EU) No 351/2012	N/A <sup>(17)</sup>	
67	Specific components for liquefied petroleum gases (LPG) and their installation on motor vehicles	Regulation (EC) No 661/2009 UNECE Regulation No 67	X	
69	Electric safety	Regulation (EC) No 661/2009 UNECE Regulation No 100	X	

---

*Status: EU Directives are being published on this site to aid cross referencing from UK legislation. After IP completion day (31 December 2020 11pm) no further amendments will be applied to this version.*

---

70	Specific components for CNG and their installation on motor vehicles	Regulation (EC) No 661/2009 UNECE Regulation No 110	X	
----	--	--	---	--

*Meaning of notes:*

X The requirements of the relevant act are applicable. The series of amendments of the UNECE Regulations which applies on a compulsory basis are listed in Annex IV to Regulation (EC) No 661/2009. Series of amendments adopted subsequently are accepted as an alternative. Member States may grant extensions to existing type-approvals granted according to the former EU Directives repealed by Regulation (EC) 661/2009 under the conditions fixed by Article 13(14) of Regulation (EC) 661/2009.

N/A This regulatory act is not applicable to this vehicle (no requirements).

<sup>(1)</sup> For vehicles with a reference mass not exceeding 2 610 kg. At the manufacturer's request, may apply to vehicles with a reference mass not exceeding 2 840 kg. With regard to Access to information, for other parts (e.g. living compartment) than the base vehicle, it is sufficient that the manufacturer provide access to repair and maintenance information in a readily accessible and prompt manner.

<sup>(2)</sup> In case of vehicles equipped with a LPG or CNG installation, a vehicle type-approval in accordance with UNECE Regulation No 67 or UNECE Regulation No 110 is required.

<sup>(3)</sup> The fitting of an ESC system is required in accordance with Article 12 of Regulation (EC) No 661/2009. The implementation dates set out in Annex V to Regulation (EC) No 661/2009 apply. In accordance with UNECE Regulation 13, the fitting of an electronic stability control ('ESC') system is not required for special purpose vehicles of categories M<sub>2</sub>, M<sub>3</sub>, N<sub>2</sub> and N<sub>3</sub> and for vehicles for exceptional load transport and trailers with areas for standing passengers. N<sub>1</sub> vehicles may be approved according to UNECE Regulation 13 or UNECE Regulation 13-H.

<sup>(4)</sup> The fitting of an ESC system is required in accordance with Article 12 of Regulation (EC) No 661/2009. Therefore, the requirements set out in Part A of Annex 9 to UNECE Regulation No 13-H shall be complied with for the purposes of EC type-approval of new types of vehicles as well as for the registration, sale and entry into service of new vehicles. The implementation dates set out in Article 13 of Regulation (EC) No 661/2009 apply. N<sub>1</sub> vehicles may be approved according to UNECE Regulation 13 or UNECE Regulation 13-H.

<sup>(4A)</sup> If fitted, the protective device shall fulfill the requirements of UNECE Regulation No 18.

<sup>(4B)</sup> This Regulation applies to seats not falling within the scope of UNECE Regulation No 80.

For other options, see Article 2 of Regulation (EC) No 595/2009.

<sup>(5)</sup> Vehicles of categories other than M<sub>1</sub> do not need to fully comply with act but shall be fitted with a suitable windscreen defrosting and demisting device.

<sup>(6)</sup> Vehicles of categories other than M<sub>1</sub> do not need to fully comply with act but shall be fitted with a suitable windscreen washing and wiping devices.



- (<sup>8</sup>) For vehicles with a reference mass exceeding 2 610 kg and which did not benefit from the possibility offered in note (<sup>1</sup>).
- (<sup>9</sup>) For vehicles with a reference mass exceeding 2 610 kg which are not type-approved (at the manufacturer's request and provided their reference mass does not exceed 2 840 kg) under Regulation (EC) No 715/2007. For other parts than the base vehicle, it is sufficient that the manufacturer provide access to repair and maintenance information in a readily accessible and prompt manner
- (<sup>9A</sup>) Applies only where such vehicles are fitted with equipment covered by UNECE Regulation No 64. Tyre pressure monitoring system for M1 vehicles applies on a compulsory basis in accordance with Article 9(2) of Regulation (EC) No 661/2009.
- (<sup>10</sup>) Applies only to vehicles equipped with coupling(s).
- (<sup>11</sup>) Applies to vehicles with a technically permissible maximum laden mass not exceeding 2,5 tonnes.
- (<sup>12</sup>) Only applicable to vehicles where the 'Seating Reference Point ("R" point)' of the lowest seat is not more than 700 mm above the ground level.
- (<sup>13</sup>) Applies only when the manufacturer applies for type-approval of vehicles intended for the transport of dangerous goods.
- (<sup>14</sup>) Applies only for vehicles of category N<sub>1</sub>, class I (reference mass ≤ 1 305 kg)
- (<sup>15</sup>) At the request of the manufacturer, a type-approval may be granted under this item, as an alternative to obtaining type-approvals under each individual item covered by Regulation (EC) No 661/2009.
- (<sup>16</sup>) The fitting of an Advanced emergency braking system is not required for special purpose vehicles in accordance with Article 1 of Regulation (EU) No 347/2012.
- (<sup>17</sup>) The fitting of a Lane departure warning system is not required for special purpose vehicles in accordance with Article 1 of Regulation (EU) No 351/2012.
- A The requirements shall be fulfilled to the greatest extent. The type-approval authority may only grant exemption(s) if the manufacturer demonstrates that the vehicle cannot meet the requirements due to its special purpose. The exemptions granted shall be described on the vehicle type-approval certificate and the certificate of conformity (remark –entry 52).
- A<sub>1</sub> The fitting of ESC is not mandatory. In the case of multi-stage approvals, where the modifications made at a particular stage are likely to affect the function of the base vehicle's ESC system, the manufacturer may either disable the system or demonstrate that the vehicle has not been rendered unsafe or unstable. This may be demonstrated, e.g., by performing rapid double lane-change manoeuvres in each direction at 80 km/h with sufficient severity to cause intervention by the ESC system. These interventions shall be well-controlled and shall act to improve stability of the vehicle. The Technical Service shall have the right to request further testing if deemed necessary.
- B Application limited to doors giving access to the seats designated for normal use when the vehicle is travelling on the road and where the distance between the R point of the seat and the average plane of the door surface, measured perpendicular to the longitudinal medium plane of the vehicle, does not exceed 500 mm.

---

*Status: EU Directives are being published on this site to aid cross referencing from UK legislation. After IP completion day (31 December 2020 11pm) no further amendments will be applied to this version.*

---

- C Application limited to that part of the vehicle in front of the rearmost seat designated for normal use when the vehicle is travelling on the road and also limited to the head impact zone as defined in the legal act.
- D Application limited to seats designated for normal use when the vehicle is travelling on the road. Seats which are not designated for use when the vehicle is travelling on the road shall be clearly identified to users either by means of a pictogram or a sign with an appropriate text. The luggage retention requirements of UNECE Regulations No. 17 shall not apply.
- E Front only.
- F Modification to the routing and length of the refuelling duct and re-positioning of the tank inboard is permissible.
- G In case of multi-stage approval, requirements according to the category of the base/incomplete vehicle (e.g. the chassis of which was used to build the special purpose vehicle) may also be used.
- H Modification of exhaust system length after the last silencer not exceeding 2 m is permissible without any further test.
- I Tyres shall be type-approved according to the requirements of UNECE Regulation No. 54 even if the design speed of the vehicle is less than 80 km/h. The load capacity may be adjusted in relation to the maximum design speed of the trailer in agreement with the tyre manufacturer.
- J For all window glazing other than driver's cab glazing (windshield and side glasses), the material may be either of safety glass or rigid plastic glazing.
- K Additional panic alarm devices permitted.
- L Application limited to seats designated for normal use when the vehicle is travelling on the road. At least anchorages for lap belts are required in the rear seating positions. Seats which are not designated for use when the vehicle is travelling on the road shall be clearly identified to users either by means of a pictogram or a sign with an appropriate text. ISOFIX is not required on Ambulances and hearses.
- M Application limited to seats designated for normal use when the vehicle is travelling on the road. At least lap belts are required in all rear seating positions. Seats which are not designated for use when the vehicle is travelling on the road shall be clearly identified to users either by means of a pictogram or a sign with an appropriate text. ISOFIX is not required on Ambulances and hearses.
- N Provided that all mandatory lighting devices are installed and that the geometric visibility is not affected.
- Q Modification of exhaust system length after the last silencer not exceeding 2 m is permissible without any further test. An EC type-approval issued to the most representative base vehicle remains valid irrespective of change in the reference weight.
- R Provided that the registration plates of all Member States can be mounted and remain visible.
- S The light transmission factor is at least 60 %, also the 'A' pillar obstruction angle is not more than 10°.

- T Test to be performed only with the complete/completed vehicle. The vehicle can be tested according to Directive 70/157/EEC. Concerning item 5.2.2.1 of Annex I to Directive 70/157/EEC the following limit values are applicable:
- (a) 81 dB(A) for vehicles with an engine power of less than 75 kW;
  - (b) 83 dB(A) for vehicles with an engine power of not less than 75 kW but less than 150 kW;
  - (c) 84 dB(A) for vehicles with an engine power of not less than 150 kW.
- U Test to be performed only with the complete/completed vehicle. Vehicles up to 4 axles shall comply with all the requirements laid down by regulatory act. Derogations are admitted for vehicles having more than 4 axles, provided that:
- they are justified by the particular construction
  - all the braking performances, related to parking, service and secondary braking laid down by the regulatory act are fulfilled.
- U<sub>1</sub> ABS is not mandatory for vehicles with hydrostatic drive.
- V As alternative, Directive 97/68/EC may also be applied.
- V<sub>1</sub> For vehicles with hydrostatic drive, Directive 97/68/EC may also be applied as alternative.
- W<sub>0</sub> Modification of exhaust system length is permitted without any further test, provided the back pressure is similar. If a new test is required, an extra 2dB(A) above the applicable limit shall be allowed.
- W<sub>1</sub> Requirements shall be complied with, but modification in the exhaust system is permitted without any further test of tailpipe emissions and CO<sub>2</sub>/fuel consumption provided the emission control devices including particulate filters (if any) are not affected. No new evaporative test shall be required on the modified vehicle on condition that the evaporative control devices are kept as fitted by the manufacturer of the base vehicle.

An EC type approval issued to the most representative base vehicle remains valid irrespective of change in the reference mass.

- W<sub>2</sub> Modification of the routing, length of the refuelling duct, fuel hoses and fuel vapour pipes is permitted without further test. Re-location of the original fuel tank is permitted provided all requirements are met. However further testing according to Annex 5 to UNECE Regulation No. 34 shall not be required.
- W<sub>3</sub> The longitudinal plane of the intended wheelchair-travelling position shall be parallel to the longitudinal plane of the vehicle.

Appropriate information shall be made available to the vehicle owner that, in order to be capable of withstanding the forces transmitted by the tie-down mechanism during the various driving conditions, a wheelchair with a structure meeting the relevant part of ISO 7176-19:2008 is recommended.

Appropriate adaptations may be made to the seats of the vehicle without further testing provided if it can be demonstrated to the technical service that their anchorages, mechanisms and head restraints provide the same level of performance.

The luggage retention requirements of UNECE Regulation No. 17 shall not apply.

---

*Status: EU Directives are being published on this site to aid cross referencing from UK legislation. After IP completion day (31 December 2020 11pm) no further amendments will be applied to this version.*

---

- W<sub>4</sub> Compliance with the legal act(s) shall be required for the boarding aids when in the resting position.
- W<sub>5</sub> Each wheelchair location shall be provided with anchorages to which a wheelchair tie-down and occupant restraint system (WTORS) shall be fitted, and which comply with the additional provisions of Appendix 3.
- W<sub>6</sub> Each wheelchair location shall be provided with occupant restraint belt that comply with the additional provisions of Appendix 3

When, due to the conversion, anchorage points for the safety belts need to be moved outside the tolerance provided for in point 7.7.1 of UNECE Regulation No.16-06, the technical service shall check whether the alteration constitutes a worst case or not. If that is the case, the test provided for in point 7.7.1. of UNECE Regulation No.16-06 shall be performed. Extension to the EC type-approval does not need to be issued. The test may be performed using components that have not undergone the conditioning test prescribed by UNECE Regulation No.16-06.

- W<sub>8</sub> For the purposes of calculations, the mass of the wheel-chair including the user shall be assumed to be 160 kg. The mass shall be concentrated at the P point of the surrogate wheelchair in its travelling position declared by the manufacturer.

Any limitation in the passenger capacity resulting from the use of wheelchair(s) shall be recorded in the owner's handbook, on side 2 of the EU type-approval certificate and in the the certificate of conformity (remark section).

- [<sup>F22</sup>W<sub>9</sub> Modification of the exhaust system length is permitted without the need for retesting, provided that the exhaust back pressure characteristics remain similar.]
- Y Provided that all mandatory lighting devices are installed.
- Z The requirements on the protrusion of open windows shall not apply to the living compartment.
- Z<sub>1</sub> Mobile cranes with more than six axles are considered to be off-road vehicles (N3G) when at least three axles are driven and provided they meet the provisions of Annex II, point 4.3 b) ii) and iii) as well as point 4.3 c).]

## [<sup>F17</sup>ANNEX XII

### SMALL SERIES AND END-OF-SERIES LIMITS

#### A.SMALL SERIES LIMITS

1. The number of units of one type of vehicle to be registered, sold or put into service per year in the European Union pursuant to Article 22 may not exceed the figures shown below for the vehicle category in question:

Category	Units
M <sub>1</sub>	1 000
M <sub>2</sub> , M <sub>3</sub>	0
N <sub>1</sub>	1 000
N <sub>2</sub> , N <sub>3</sub>	0

*Status: EU Directives are being published on this site to aid cross referencing from UK legislation. After IP completion day (31 December 2020 11pm) no further amendments will be applied to this version.*

O <sub>1</sub> , O <sub>2</sub>	0
O <sub>3</sub> , O <sub>4</sub>	0

2. The number of units of one type of vehicle to be registered, sold or put into service per year in one Member State pursuant to Article 23 shall be determined by that Member State but shall not exceed the figures shown below for the vehicle category in question:

Category	Units
M <sub>1</sub>	100
M <sub>2</sub> , M <sub>3</sub>	250
N <sub>1</sub>	500 until 31 October 2016 250 from 1 November 2016
N <sub>2</sub> , N <sub>3</sub>	250
O <sub>1</sub> , O <sub>2</sub>	500
O <sub>3</sub> , O <sub>4</sub>	250

3. The number of units of one type of vehicle to be registered, sold or put into service per year in one Member State for the purposes of Article 6(2) of Commission Regulation (EU) No 1230/2012 shall be determined by each Member State but shall not exceed the figures shown below for the vehicle category in question:

Category	Units
M <sub>2</sub> , M <sub>3</sub>	1 000
N <sub>2</sub> , N <sub>3</sub>	1 200
O <sub>3</sub> , O <sub>4</sub>	2 000

## B. END-OF-SERIES LIMITS

The maximum number of complete and completed vehicles put into service in each Member State under the procedure 'End-of-Series' shall be restricted in one of the following ways to be chosen by the Member State:

- The maximum number of vehicles of one or more types may not exceed 10 %, in the case of category M<sub>1</sub>, and may not exceed 30 % of the vehicles of all types concerned put into service in that Member State during the previous year, in the case of all other categories.  
  
Should 10 %, respectively 30 %, be less than 100 vehicles, then the Member State may allow the putting into service of a maximum of 100 vehicles.
- Vehicles of any one type shall be restricted to those for which a valid certificate of conformity was issued on or after the date of manufacture and which remained valid for at least three months after its date of issue but subsequently lost its validity due to the entry into force of a regulatory act.]

---

*Status: EU Directives are being published on this site to aid cross referencing from UK legislation. After IP completion day (31 December 2020 11pm) no further amendments will be applied to this version.*

---

## ANNEX XIII

LIST OF PARTS OR EQUIPMENT WHICH ARE CAPABLE OF POSING A SIGNIFICANT RISK TO THE CORRECT FUNCTIONING OF SYSTEMS THAT ARE ESSENTIAL FOR THE SAFETY OF THE VEHICLE OR ITS ENVIRONMENTAL PERFORMANCE, THEIR PERFORMANCE REQUIREMENTS, APPROPRIATE TEST PROCEDURES, MARKING AND PACKAGING PROVISIONS

I. Parts or equipment having a significant impact on vehicle safety

Item No	Item description	Performance requirement	Test procedure	Marking requirement	Packaging requirements
1	[...]				
2					
3					

II. Parts or equipment having a significant impact on the environmental performance of the vehicle

Item No	Item description	Performance requirement	Test procedure	Marking requirement	Packaging requirements
1	[...]				
2					
3					

## ANNEX XIV

LIST OF EC TYPE-APPROVALS ISSUED PURSUANT TO REGULATORY ACTS

Type-approval authority stamp

List number:

Covering the period: ... to ...

The following information in respect of each EC type-approval granted, refused or withdrawn in the above mentioned period must be given:

Manufacturer:

EC type-approval number:

Reason for extension (where applicable):

Make:

Type:

Date of issue:

First date of issue (in the case of extensions):

## [<sup>F27</sup>ANNEX XV

### REGULATORY ACTS FOR WHICH A MANUFACTURER MAY BE DESIGNATED AS TECHNICAL SERVICE

#### 0. Objectives and scope

- 0.1. This Annex lays down the list of the regulatory acts for which a manufacturer may be designated as technical service in accordance with Article 41(6).
- 0.2. It also includes appropriate provisions concerning the designation of a manufacturer as technical service, to be applied in the framework of the type-approval of vehicles, components and separate technical units concerned by Part I of Annex IV.
- 0.3. However it does not apply to manufacturers which apply for small series approval in accordance with Article 22.

#### 1. Appointment of a manufacturer as technical service

- 1.1. A manufacturer appointed as technical service is a manufacturer who has been designated by the approval authority as a testing laboratory to carry out approval tests on its behalf in the meaning of point 31 of Article 3.

In accordance with Article 41(6), a manufacturer may only be designated as technical service for category A activities.

- 1.2. The expression ‘to carry out test’ is not restricted to the measurement of performances but covers also the registration of test results and the submission of a report to the approval authority including the relevant conclusions.

It covers the checking of compliance with those provisions which do not necessarily require measurement. This is the case for the assessment of the design against legislative requirements.

For example, ‘check compliance of the location of the fuel tank in a vehicle with the provisions of point 5.10 of Annex I to Directive 70/221/EEC’ has to be understood as part of ‘to carry out test’.

#### [<sup>F22</sup> List of regulatory acts and restrictions

	<b>Subject</b>	<b>Regulatory act reference</b>
4	Rear registration plate space	Directive 70/222/EEC
4A	Space for mounting and fixing rear registration plates	Regulation (EC) No 661/2009 Regulation (EU) No 1003/2010
7	Audible warning	Directive 70/388/EEC
7A	Audible warning devices and signals	Regulation (EC) No 661/2009 UNECE Regulation No 28
10	Radio interference (electromagnetic compatibility)	Directive 72/245/EEC

*Status: EU Directives are being published on this site to aid cross referencing from UK legislation. After IP completion day (31 December 2020 11pm) no further amendments will be applied to this version.*

10A	Electromagnetic compatibility	Regulation (EC) No 661/2009 UNECE Regulation No 10
18	Plates (statutory)	Directive 76/114/EEC
18A	Manufacturer's statutory plate and vehicle identification number	Regulation (EC) No 661/2009 Regulation (EU) No 19/2011
20	Installation of lighting and light signalling devices	Directive 76/756/EEC
20A	Installation of lighting and light-signalling devices on vehicles	Regulation (EC) No 661/2009 UNECE Regulation No 48
27	Towing hooks	Directive 77/389/EEC
27A	Towing device	Regulation (EC) No 661/2009 Regulation (EU) No 1005/2010
33	Identification of controls, tell-tales and indicators	Directive 78/316/EEC
33A	Location and identification of hand controls, tell-tales and indicators	Regulation (EC) No 661/2009 UNECE Regulation No 121
34	Defrost/demist	Directive 78/317/EEC
34A	Windscreen defrosting and demisting systems	Regulation (EC) No 661/2009 Regulation (EU) No 672/2010
35	Wash/wipe	Directive 78/318/EEC
35A	Windscreen wiper and washer systems	Regulation (EC) No 661/2009 Regulation (EU) No 1008/2010
36	Heating systems	Directive 2001/56/EC Except the provisions in Annex VIII relating to LPG combustion heaters and LPG heating systems
36A	Heating systems	Regulation (EC) No 661/2009 UNECE Regulation No 122 Except the provisions in Annex 8 relating to LPG combustion heaters and LPG heating systems



**Status:** EU Directives are being published on this site to aid cross referencing from UK legislation. After IP completion day (31 December 2020 11pm) no further amendments will be applied to this version.

37	Wheel guards	Directive 78/549/EEC
37A	Wheel guards	Regulation (EC) No 661/2009 Regulation (EU) No 1009/2010
44	Masses and dimensions (cars)	Directive 92/21/EEC
44A	Masses and dimensions	Regulation (EC) No 661/2009 Regulation (EU) No 1230/2012
45	Safety glazing	Directive 92/22/EEC Restricted to the provisions included in Annex III
45A	Safety glazing materials and their installation on vehicles	Regulation (EC) No 661/2009 UNECE Regulation No 43 Restricted to the provisions included in Annex 21
46	Tyres	Directive 92/23/EEC
46A	Installation of tyres	Regulation (EC) No 661/2009 Regulation (EU) No 458/2011
48	Masses and dimensions (other than vehicles referred to in item 44)	Directive 97/27/EC
48A	Masses and dimensions	Regulation (EC) No 661/2009 Regulation (EU) No 1230/2012
49	External projections of cabs	Directive 92/114/EEC
49A	Commercial vehicles with regard to their external projections forward of the cab's rear panel	Regulation (EC) No 661/2009 UNECE Regulation No 61
50	Couplings	Directive 94/20/EC Restricted to the provisions included in Annex V (up to and including point 8) and Annex VII
50A	Mechanical coupling components of combinations of vehicles	Regulation (EC) No 661/2009 UNECE Regulation No 55 Restricted to the provisions included in Annex 5 (up to

---

**Status:** EU Directives are being published on this site to aid cross referencing from UK legislation. After IP completion day (31 December 2020 11pm) no further amendments will be applied to this version.

---

		and including paragraph 8) and Annex 7
61	Air-conditioning system	Directive 2006/40/EC]

## Appendix

### Designation of a manufacturer as technical service

#### 1. General

- 1.1. The designation and notification of a manufacturer as technical service shall be made in accordance with the provisions of Articles 41, 42 and 43 as well with the practical measures included in this Appendix.
- 1.2. The manufacturer shall be accredited under Standard EN ISO/IEC 17025:2005 — General requirements for the competence of testing and calibration laboratories.

#### 2. Subcontracting

- 2.1. In accordance with the provisions of Article 41(6) first subparagraph, a manufacturer may nominate a subcontractor for performing tests on his behalf.

By subcontractor it shall be understood:

- a) either a subsidiary which is entrusted with testing activities by the manufacturer inside its own organisation; or
  - b) a third party under contract with the manufacturer to perform test activities.
- 2.2. Turning to the services of a subcontractor does not remove the obligation for the manufacturer to comply with the provisions of Article 41 in particular those concerning the skills of the technical services and compliance with Standard EN ISO/IEC 17025:2005.
  - 2.3. Section 1 of Annex XV shall apply to the subcontractor.

#### 3. Test report

Test reports shall be drafted in accordance with the general requirements set out in Appendix 3 of Annex V to Directive 2007/46/EC.]

## [<sup>F27</sup>ANNEX XVI

### SPECIFIC CONDITIONS REQUIRED FROM VIRTUAL TESTING METHODS AND REGULATORY ACTS FOR WHICH VIRTUAL TESTING METHODS MAY BE USED BY A MANUFACTURER OR A TECHNICAL SERVICE

#### 0. Objectives and scope

This Annex lays down appropriate provisions concerning virtual testing in accordance with Article 11(3).

It shall not apply to the second subparagraph of Article 11(2).

#### [<sup>F21</sup>1. List of regulatory acts

	Subject	Regulatory act reference
3	Fuel tanks/rear protective devices	Directive 70/221/EEC

*Status: EU Directives are being published on this site to aid cross referencing from UK legislation. After IP completion day (31 December 2020 11pm) no further amendments will be applied to this version.*

3B	Rear underrun protective devices (RUPDs) and their installation; rear underrun protection (RUP)	Regulation (EC) No 661/2009 UNECE Regulation No 58
6	Door latches and hinges	Directive 70/387/EEC
6A	Vehicle access and manoeuvrability	Regulation (EC) No 661/2009 Regulation (EU) No 130/2012
6B	Door latches and door retention components	Regulation (EC) No 661/2009 UNECE Regulation No 11
8	Indirect vision devices	Directive 2003/97/EC
8A	Devices for indirect vision and their installation	Regulation (EC) No 661/2009 UNECE Regulation No 46
12	Interior fittings	Directive 74/60/EEC
12A	Interior fittings	Regulation (EC) No 661/2009 UNECE Regulation No 21
16	Exterior projections	Directive 74/483/EEC
16A	External projections	Regulation (EC) No 661/2009 UNECE Regulation No 26
20	Installation of lighting and light signalling devices	Directive 76/756/EEC
20A	Installation of lighting and light-signalling devices on vehicles	Regulation (EC) No 661/2009 UNECE Regulation No 48
27	Towing hooks	Directive 77/389/EEC
27A	Towing device	Regulation (EC) No 661/2009 Regulation (EU) No 1005/2010
32	Forward vision	Directive 77/649/EEC
32A	Forward field of vision	Regulation (EC) No 661/2009 UNECE Regulation No 125
35	Wash/wipe	Directive 78/318/EEC
35A	Windscreen wiper and washer systems	Regulation (EC) No 661/2009 Regulation (EU) No 1008/2010

*Status: EU Directives are being published on this site to aid cross referencing from UK legislation. After IP completion day (31 December 2020 11pm) no further amendments will be applied to this version.*

37	Wheel guards	Directive 78/549/EEC
37A	Wheel guards	Regulation (EC) No 661/2009 Regulation (EU) No 1009/2010
42	Lateral protection	Directive 89/297/EEC
42A	Lateral protection of goods vehicles	Regulation (EC) No 661/2009 UNECE Regulation No 73
48A	Masses and dimensions	Regulation (EC) No 661/2009 Regulation (EU) No 1230/2012
49	External projections of cabs	Directive 92/114/EEC
49A	Commercial vehicles with regard to their external projections forward of the cab's rear panel	Regulation (EC) No 661/2009 UNECE Regulation No 61
50	Couplings	Directive 94/20/EC
50A	Mechanical coupling components of combinations of vehicles	Regulation (EC) No 661/2009 UNECE Regulation No 55
50B	Close-coupling device (CCD); fitting of an approved type of CCD	Regulation (EC) No 661/2009 UNECE Regulation No 102
52	Buses and coaches	Directive 2001/85/EC
52A	M <sub>2</sub> and M <sub>3</sub> vehicles	Regulation (EC) No 661/2009 UNECE Regulation No 107
52B	Strength of the superstructure of large passenger vehicles	Regulation (EC) No 661/2009 UNECE Regulation No 66
57	Front underrun protection	Directive 2000/40/EC
57A	Front underrun protective devices (FUPDs) and their installation; front underrun protection (FUP)	Regulation (EC) No 661/2009 UNECE Regulation No 93]

---

*Status: EU Directives are being published on this site to aid cross referencing from UK legislation. After IP completion day (31 December 2020 11pm) no further amendments will be applied to this version.*

---

## Appendix 1

### General conditions required from virtual testing methods

#### 1. Virtual test pattern

The following scheme shall be used as basis structure for describing and conducting virtual testing:

- (a) purpose;
- (b) structure model;
- (c) boundary conditions;
- (d) load assumptions;
- (e) calculation;
- (f) assessment;
- (g) documentation.

#### 2. Fundamentals of computer simulation and calculation

##### 2.1. *Mathematical model*

The mathematical model shall be supplied by the manufacturer. It shall reflect the complexity of the structure of the vehicle, system and components to be tested in relation to the requirements of the regulatory act and its boundary conditions.

The same provisions shall apply *mutatis mutandis* for testing components or technical units independently from the vehicle.

##### 2.2. *Validation process of the mathematical model*

The mathematical model shall be validated in comparison with the actual test conditions.

To that effect a physical test shall be conducted for the purposes of comparing the results obtained when using the mathematical model with the results of a physical test. Comparability of the test results shall be proven. A validation report shall be drafted by the manufacturer or by the technical service and submitted to the approval authority.

Any change made to the mathematical model or to the software likely to invalidate the validation report shall be brought to the attention of the approval authority which may require that a new validation process is conducted.

The flow chart of the validation process is shown in Appendix 3.

##### 2.3. *Documentation*

The data and auxiliary tools used for the simulation and calculation shall be made available by the manufacturer and be documented in a suitable way.

#### 3. Tools and support

At the request of the technical service, the manufacturer shall supply or provide access to the necessary tools including appropriate software.

In addition he shall provide appropriate support to the technical service.

---

**Status:** EU Directives are being published on this site to aid cross referencing from UK legislation. After IP completion day (31 December 2020 11pm) no further amendments will be applied to this version.

---

Providing access and support to a technical service does not remove any obligation of the technical service regarding the skills of its personnel, the payment of licence rights and respect of confidentiality.

*Status: EU Directives are being published on this site to aid cross referencing from UK legislation. After IP completion day (31 December 2020 11pm) no further amendments will be applied to this version.*

## [<sup>F2</sup>Appendix 2

### Specific conditions concerning virtual testing methods

#### 1. List of regulatory acts

	<b>Regulatory act reference</b>	<b>Annex and paragraphs</b>	<b>Specific conditions</b>
3	Directive 70/221/EEC	Annex II, points 5.2 and 5.4.5	Rear underrun dimensions and resistance to forces
3B	Regulation (EC) No 661/2009 UNECE Regulation No 58	Paragraphs 2.3, 7.3 and 25.6	Dimensions and resistance to forces
6	Directive 70/387/EEC	Annex II, point 4.3	Equivalent methods for tensile strength tests and resistance of latches to acceleration
6A	Regulation (EC) No 661/2009 Regulation (EU) No 130/2012	Annex II, Part I and 2	Dimensions of steps, running boards and handholds
6B	Regulation (EC) No 661/2009 UNECE Regulation No 11	Annex 3 Annex 4, point 2.1 Annex 5	Tensile strength tests and resistance of latches to acceleration
8	Directive 2003/97/EC	Annex III All provisions in Sections 3, 4 and 5.	Prescribed fields of vision of rear-view mirrors.
8A	Regulation (EC) No 661/2009 UNECE Regulation No 46	Paragraph 15.2.4	Prescribed fields of vision of rear-view mirrors.
12	Directive 74/60/EEC	(a) Annex I, all provisions in point 5 (Specifications) (b) Annex II	(a) Measurement of all radii of curvature and of all projections except for those requirements where a force has to be applied in order to check compliance



**Status:** EU Directives are being published on this site to aid cross referencing from UK legislation. After IP completion day (31 December 2020 11pm) no further amendments will be applied to this version.

			(b) with the provisions. Determination of the head-impact zone.
12A	Regulation (EC) No 661/2009 UNECE Regulation No 21	(a) Paragraph 5 to 5.7 (b) Paragraph 2.3	(a) Measurement of all radii of curvature and of all projections except for those requirements where a force has to be applied in order to check compliance with the provisions. (b) Determination of the head-impact zone.
16	Directive 74/483/EEC	Annex I, all provisions in point 5 (General specifications) and point 6 (Particular specifications).	Measurement of all radii of curvature and of all projections except for those requirements where a force has to be applied in order to check compliance with the provisions.
16A	Regulation (EC) No 661/2009 UNECE Regulation No 26	Paragraph 5.2.4	Measurement of all radii of curvature and of all projections except for those requirements where a force has to be applied in order to check compliance with the provisions.
20	Directive 76/756/EEC	Paragraph 6 (Individual specifications) of UNECE Regulation No 48. Provisions of Annexes 4, 5 and 6 to	The test drive provided for in point 6.22.9.2.2 shall be performed on a real vehicle.

*Status: EU Directives are being published on this site to aid cross referencing from UK legislation. After IP completion day (31 December 2020 11pm) no further amendments will be applied to this version.*

		UNECE Regulation No 48.	
20A	Regulation (EC) No 661/2009 UNECE Regulation No 48	Paragraph 6, Annexes 4, 5 and 6	The test drive provided for in point 6.22.9.2.2 shall be performed on a real vehicle.
27	Directive 77/389/EEC	Annex II, point 2	Tractive and compressive static force
27A	Regulation (EC) No 661/2009 Regulation (EU) No 1005/2010	Annex II, point 1.2	Tractive and compressive static force
32	Directive 77/649/EEC	Annex I, point 5 (Specifications)	Obstructions and field of vision
32A	Regulation (EC) No 661/2009 UNECE Regulation No 125	Paragraph 5	Obstructions and field of vision
35	Directive 78/318/EEC	Annex I, point 5.1.2	Determination of the swept area only.
35A	Regulation (EC) No 661/2009 Regulation (EU) No 1008/2010	Annex III, points 1.1.2 and 1.1.3	Determination of the swept area only.
37	Directive 78/549/EEC	Annex I, point 2 (Special requirements)	
37A	Regulation (EC) No 661/2009 Regulation (EU) No 1009/2010	Annex II, point 2	Verification of the dimensional requirements
42	Directive 89/297/EEC	Annex, point 2.8	Resistance under a horizontal force and deflection measurement.
42A	Regulation (EC) No 661/2009 UNECE Regulation No 73	Paragraph 12.10	Resistance under a horizontal force and deflection measurement.
48A	Regulation (EC) No 661/2009 Regulation (EU) No 1230/2012	(a) Annex I, Part B, points 7 and 8	(a) Check of compliance with the manoeuvrability requirements

		(b) Annex I, Part C, points 6 and 7	including manoeuvrability of vehicles fitted with lift- or loadable axles. (b) Measurement of the maximum rear swing-out.
49	Directive 92/114/EEC	Annex I, point 4 (Specific requirements)	Measurement of all radii of curvature and of all projections except for those requirements where a force has to be applied in order to check compliance with the provisions.
49A	Regulation (EC) No 661/2009 UNECE Regulation No 61	Paragraphs 5 and 6	Measurement of all radii of curvature and of all projections except for those requirements where a force has to be applied in order to check compliance with the provisions.
50	Directive 94/20/EC	(a) Annex V 'Requirements for mechanical coupling Devices' (b) Annex VI, point 1.1 (c) Annex VI, point 4 (Testing of mechanical coupling devices)	(a) All provisions of points 1 to 8 included. (b) Strength tests on mechanical couplings of simple design may be replaced by virtual tests. (c) Points 4.5.1 (Strength test), 4.5.2 (Resistance to buckling) and 4.5.3 (Resistance

*Status: EU Directives are being published on this site to aid cross referencing from UK legislation. After IP completion day (31 December 2020 11pm) no further amendments will be applied to this version.*

				to bending moment) only.
50A	Regulation (EC) No 661/2009 UNECE Regulation No 55	(a)  (b)  (c)	Annex 5 'Requirements for mechanical coupling Devices' Annex 6, paragraph 1.1 Annex 6, paragraph 3	(a) All provisions of paragraphs 1 to 8 included. (b) Strength tests on mechanical couplings of simple design may be replaced by virtual tests. (c) Paragraphs 3.6.1 (Strength test), 3.6.2 (Resistance to buckling) and 3.6.3 (Resistance to bending moment) only.
52	Directive 2001/85/EC	(a) (b)	Annex I Annex IV Strength of superstructure	(a) Point 7.4.5 Stability test under the conditions specified in the Appendix to Annex I. (b) Appendix 4 — Verification of strength of the superstructure by calculation.
52A	Regulation (EC) No 661/2009 UNECE Regulation No 107	Annex 3		Paragraph 7.4.5 (calculation method)
52B	Regulation (EC) No 661/2009	Annex 9		Computer simulation of rollover test on

---

**Status:** EU Directives are being published on this site to aid cross referencing from UK legislation. After IP completion day (31 December 2020 11pm) no further amendments will be applied to this version.

---

	UNECE Regulation No 66		complete vehicle as an equivalent approval method
57	Directive 2000/40/EC	Paragraph 3 of Annex 5 to UNECE Regulation 93.	Resistance under a horizontal force and deflection measurement.
57A	Regulation (EC) No 661/2009 UNECE Regulation No 93	Annex 5, Paragraph 3.	Resistance under a horizontal force and deflection measurement.]

## Appendix 3

## Validation process]

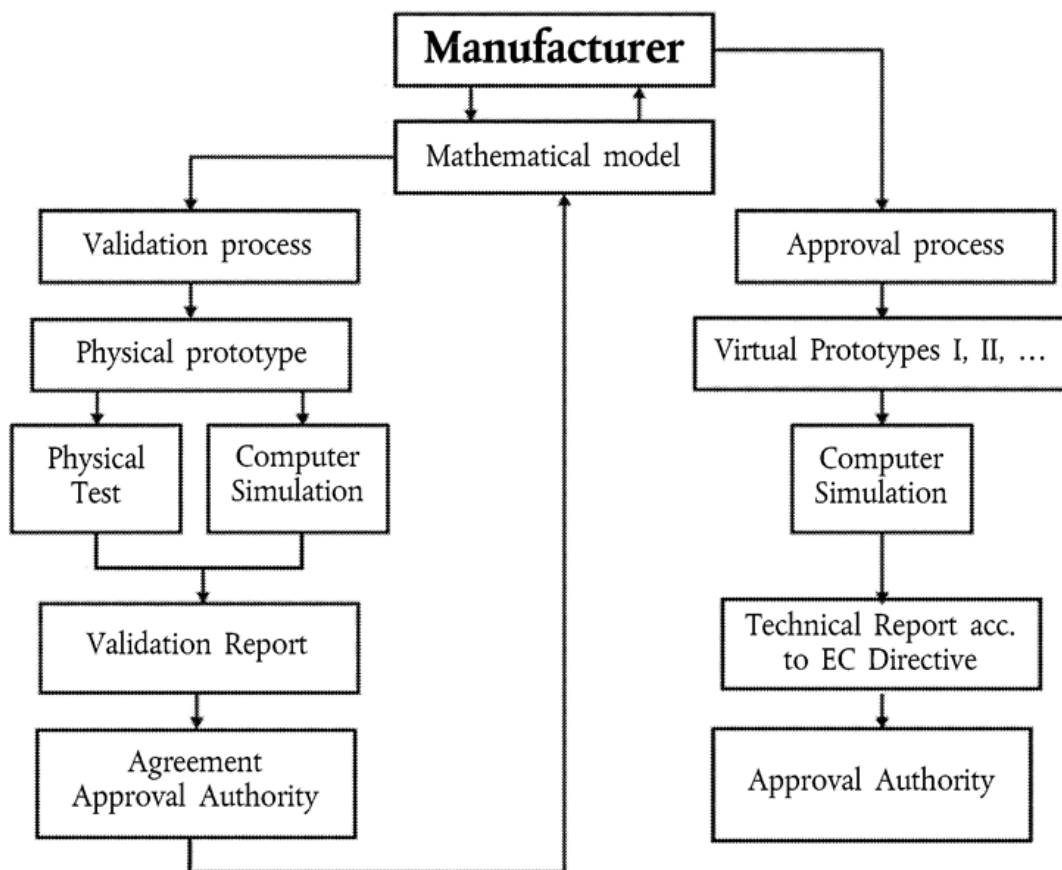

## ANNEX XVII

## PROCEDURES TO BE FOLLOWED DURING MULTI-STAGE EC TYPE-APPROVAL

## 1. GENERAL

- 1.1. The satisfactory operation of the process of multi-stage EC type-approval requires joint action by all the manufacturers concerned. To this end approval authorities must ensure, before granting first and subsequent stage approval, that suitable arrangements exist between the relevant manufacturers for the supply and interchange of documents and information such that the completed vehicle type meets the technical requirements of all the relevant regulatory acts as prescribed in Annex IV or Annex XI. Such information must include details of relevant system, component and separate technical unit approvals and of vehicle parts which form part of the incomplete vehicle but are not yet approved.
- 1.2. EC type-approvals in accordance with this Annex are granted on the basis of the current state of completion of the vehicle type and must incorporate all approvals granted at earlier stages.

1.3. Each manufacturer in a multi-stage EC type-approval process is responsible for the approval and conformity of production of all systems, components or separate technical units manufactured by him or added by him to the previously built stage. He is not responsible for subjects which have been approved in an earlier stage except in those cases where he modifies relevant parts to an extent that the previously granted approval becomes invalid.

## 2. PROCEDURES

The type-approval authority must:

- (a) verify that all EC type-approval certificates issued pursuant to the regulatory acts which are applicable for vehicle type-approval cover the vehicle type at its state of completion and correspond to the prescribed requirements;
- (b) ensure that all the relevant data, taking account of the state of completion of the vehicle, is included in the information folder;
- (c) by reference to the documentation make sure that the vehicle specification(s) and data contained in Part I of the vehicle information folder are included in the data in the information packages and in the EC type-approval certificates, in respect of the relevant regulatory acts; and in the case of a completed vehicle, where an item number in Part I of the information folder is not included in the information package of any of the regulatory acts, confirm that the relevant part of characteristic conforms to the particulars in the information folder;
- (d) on a selected sample of vehicles from the type to be approved carry out or arrange to be carried out inspections of vehicle parts and systems to verify that the vehicle(s) is/are built in accordance with the relevant data contained in the authenticated information package in respect of all relevant regulatory acts;
- (e) carry out or arrange to be carried out relevant installation checks in respect of separate technical units where applicable.

3. The number of vehicles to be inspected for the purposes of paragraph 2(d) must be sufficient to permit the proper control of the various combinations to be EC type-approved according to the state of completion of the vehicle and the following criteria:

- engine,
- gearbox,
- powered axles (number, position, interconnection),
- steered axles (number and position),
- body styles,
- number of doors,
- hand of drive,
- number of seats,
- level of equipment.

## 4. IDENTIFICATION OF THE VEHICLE

### 4.1. Vehicle identification number

- (a) The identification number of the base vehicle (VIN) prescribed by Directive 76/114/EEC shall be retained during all the subsequent stages of the type-approval process to ensure the ‘traceability’ of the process.

---

*Status: EU Directives are being published on this site to aid cross referencing from UK legislation. After IP completion day (31 December 2020 11pm) no further amendments will be applied to this version.*

---

- (b) However, at the final stage of completion, the manufacturer concerned by this stage may replace, in agreement with the approval authority, the first and second sections of the vehicle identification number by his own vehicle manufacturer code and the vehicle identification code if, and only if, the vehicle has to be registered under his own trade name. In such a case, the complete vehicle identification number of the base vehicle shall not be deleted.

#### 4.2. Additional manufacturer's plate

At the second and subsequent stages, in addition to the statutory plate prescribed by Directive 76/114/EEC, each manufacturer must affix to the vehicle an additional plate the model of which is shown in the appendix to this Annex. This plate must be firmly attached, in a conspicuous and readily accessible position on a part not subject to replacement in use. It must show clearly and indelibly the following information in the order listed:

- name of the manufacturer,
- Sections 1, 3 and 4 of the EC type-approval number,
- the stage of approval,
- vehicle identification number,
- maximum permissible laden mass of the vehicle<sup>(107)</sup>,
- maximum permissible laden mass of the combination (where the vehicle is permitted to tow a trailer)<sup>(107)</sup>,
- maximum permissible mass on each axle, listed in order from front to rear<sup>(107)</sup>,
- in the case of a semi-trailer or centre axle trailer, the maximum permitted mass on the coupling device<sup>(107)</sup>.

Unless otherwise provided for above, the plate must comply with the requirements of Directive 76/114/EEC.



**Status:** EU Directives are being published on this site to aid cross referencing from UK legislation. After IP completion day (31 December 2020 11pm) no further amendments will be applied to this version.

## Appendix

### MODEL OF THE MANUFACTURER'S ADDITIONAL PLATE

The example below is given as a guide only.

MANUFACTURER'S NAME (stage 3)
e2*98/14*2609
Stage 3
WD9VD58D98D234560
1 500 kg
2 500 kg
1-700 kg
2-810 kg

### F<sup>24</sup> ANNEX XVIII

.....

### ANNEX XIX

#### TIMETABLE FOR THE ENFORCEMENT OF THIS DIRECTIVE IN RESPECT OF TYPE-APPROVAL

Categories concerned	Enforcement dates		
	New types of vehicles Optional	New types of vehicles Obligatory	Existing types of vehicles Obligatory
M <sub>1</sub>	N.A. <sup>a</sup>	29 April 2009	N.A. <sup>a</sup>
Special-purpose vehicles of category M <sub>1</sub>	29 April 2009	29 April 2011	29 April 2012
Incomplete and complete vehicles of category N <sub>1</sub>	29 April 2009	29 October 2010	29 October 2011
Completed vehicles of category N <sub>1</sub>	29 April 2009	29 October 2011	29 April 2013

**a** Not applicable.

**b** For the purposes of the application of Article 45(4), this date is postponed by 12 months.

---

**Status:** EU Directives are being published on this site to aid cross referencing from UK legislation. After IP completion day (31 December 2020 11pm) no further amendments will be applied to this version.

---

Incomplete and complete vehicles of categories N <sub>2</sub> , N <sub>3</sub> , O <sub>1</sub> , O <sub>2</sub> , O <sub>3</sub> , O <sub>4</sub>	29 April 2009	29 October 2010	29 October 2012
Incomplete and complete vehicles of categories M <sub>2</sub> , M <sub>3</sub> ,	29 April 2009	29 April 2009 <sup>b</sup>	29 October 2010
Special-purpose vehicles of categories N <sub>1</sub> , N <sub>2</sub> , N <sub>3</sub> , M <sub>2</sub> , M <sub>3</sub> , O <sub>1</sub> , O <sub>2</sub> , O <sub>3</sub> , O <sub>4</sub>	29 April 2009	29 October 2012	29 October 2014
Completed vehicles of categories N <sub>2</sub> , N <sub>3</sub>	29 April 2009	29 October 2012	29 October 2014
Completed vehicles of categories M <sub>2</sub> , M <sub>3</sub>	29 April 2009	29 April 2010 <sup>b</sup>	29 October 2011
Completed vehicles of categories O <sub>1</sub> , O <sub>2</sub> , O <sub>3</sub> , O <sub>4</sub>	29 April 2009	29 October 2011	29 October 2013

**a** Not applicable.

**b** For the purposes of the application of Article 45(4), this date is postponed by 12 months.

---

**Status:** EU Directives are being published on this site to aid cross referencing from UK legislation. After IP completion day (31 December 2020 11pm) no further amendments will be applied to this version.

## ANNEX XX

TIME-LIMITS FOR THE TRANSPOSITION OF  
REPEALED DIRECTIVES INTO NATIONAL LAW

## PART A

**Directive 70/156/EEC and its successive amending acts**

<b>Directives/regulations</b>	<b>Comments</b>
Directive 70/156/EEC <sup>a</sup>	
Directive 78/315/EEC <sup>b</sup>	
Directive 78/547/EEC <sup>c</sup>	
Directive 80/1267/EEC <sup>d</sup>	
Directive 87/358/EEC <sup>e</sup>	
<b>a</b>	OJ L 42, 23.2.1970, p. 1.
<b>b</b>	OJ L 81, 28.3.1978, p. 1.
<b>c</b>	OJ L 168, 26.6.1978, p. 39.
<b>d</b>	OJ L 375, 31.12.1980, p. 34.
<b>e</b>	OJ L 192, 11.7.1987, p. 51.
<b>f</b>	OJ L 220, 8.8.1987, p. 44.
<b>g</b>	OJ L 225, 10.8.1992, p. 1.
<b>h</b>	OJ L 264, 23.10.1993, p. 49.
<b>i</b>	OJ L 266, 8.11.1995, p. 1.
<b>j</b>	OJ L 169, 8.7.1996, p. 1.
<b>k</b>	OJ L 18, 21.1.1997, p. 7.
<b>l</b>	OJ L 233, 25.8.1997, p. 1.
<b>m</b>	OJ L 91, 25.3.1998, p. 1.
<b>n</b>	OJ L 11, 16.1.1999, p. 25.
<b>o</b>	OJ L 203, 10.8.2000, p. 9.
<b>p</b>	OJ L 291, 8.11.2001, p. 24.
<b>q</b>	OJ L 292, 9.11.2001, p. 21.
<b>r</b>	OJ L 42, 13.2.2002, p. 42.
<b>s</b>	OJ L 18, 21.1.2002, p. 1.
<b>t</b>	OJ L 122, 16.5.2003, p. 36.
<b>u</b>	OJ L 25, 29.1.2004, p. 1.
<b>v</b>	OJ L 321, 6.12.2003, p. 15.
<b>w</b>	OJ L 49, 19.2.2004, p. 36.
<b>x</b>	OJ L 153, 30.4.2004, p. 107.
<b>y</b>	OJ L 337, 13.11.2004, p. 13.
	OJ L 194, 26.7.2005, p. 12.

*Status: EU Directives are being published on this site to aid cross referencing from UK legislation. After IP completion day (31 December 2020 11pm) no further amendments will be applied to this version.*

Directive 87/403/EEC <sup>f</sup>	
Directive 92/53/EEC <sup>g</sup>	
Directive 93/81/EEC <sup>h</sup>	
Directive 95/54/EC <sup>i</sup>	Article 3 only.
Directive 96/27/EC <sup>j</sup>	Article 3 only.
Directive 96/79/EC <sup>k</sup>	Article 3 only.
Directive 97/27/EC <sup>l</sup>	Article 8 only.
Directive 98/14/EC <sup>m</sup>	
Directive 98/91/EC <sup>n</sup>	Article 3 only.
Directive 2000/40/EC <sup>o</sup>	Article 4 only.
Directive 2001/92/EC <sup>p</sup>	Article 3 only.
<b>a</b>	OJ L 42, 23.2.1970, p. 1.
<b>b</b>	OJ L 81, 28.3.1978, p. 1.
<b>c</b>	OJ L 168, 26.6.1978, p. 39.
<b>d</b>	OJ L 375, 31.12.1980, p. 34.
<b>e</b>	OJ L 192, 11.7.1987, p. 51.
<b>f</b>	OJ L 220, 8.8.1987, p. 44.
<b>g</b>	OJ L 225, 10.8.1992, p. 1.
<b>h</b>	OJ L 264, 23.10.1993, p. 49.
<b>i</b>	OJ L 266, 8.11.1995, p. 1.
<b>j</b>	OJ L 169, 8.7.1996, p. 1.
<b>k</b>	OJ L 18, 21.1.1997, p. 7.
<b>l</b>	OJ L 233, 25.8.1997, p. 1.
<b>m</b>	OJ L 91, 25.3.1998, p. 1.
<b>n</b>	OJ L 11, 16.1.1999, p. 25.
<b>o</b>	OJ L 203, 10.8.2000, p. 9.
<b>p</b>	OJ L 291, 8.11.2001, p. 24.
<b>q</b>	OJ L 292, 9.11.2001, p. 21.
<b>r</b>	OJ L 42, 13.2.2002, p. 42.
<b>s</b>	OJ L 18, 21.1.2002, p. 1.
<b>t</b>	OJ L 122, 16.5.2003, p. 36.
<b>u</b>	OJ L 25, 29.1.2004, p. 1.
<b>v</b>	OJ L 321, 6.12.2003, p. 15.
<b>w</b>	OJ L 49, 19.2.2004, p. 36.
<b>x</b>	OJ L 153, 30.4.2004, p. 107.
<b>y</b>	OJ L 337, 13.11.2004, p. 13.
	OJ L 194, 26.7.2005, p. 12.

**Status:** EU Directives are being published on this site to aid cross referencing from UK legislation. After IP completion day (31 December 2020 11pm) no further amendments will be applied to this version.

Directive 2001/56/EC <sup>q</sup>	Article 7 only.
Directive 2001/85/EC <sup>r</sup>	Article 4 only.
Directive 2001/116/EC <sup>s</sup>	
Regulation (EC) No 807/2003 <sup>t</sup>	Point (2) of Annex III only
Directive 2003/97/EC <sup>u</sup>	Only Article 4
Directive 2003/102/EC <sup>v</sup>	Only Article 6
Directive 2004/3/EC <sup>w</sup>	Only Article 1
Directive 2004/78/EC <sup>x</sup>	Only Article 2
Directive 2004/104/EC <sup>y</sup>	Only Article 3
Directive 2005/49/EC	Only Article 2
<b>a</b>	OJ L 42, 23.2.1970, p. 1.
<b>b</b>	OJ L 81, 28.3.1978, p. 1.
<b>c</b>	OJ L 168, 26.6.1978, p. 39.
<b>d</b>	OJ L 375, 31.12.1980, p. 34.
<b>e</b>	OJ L 192, 11.7.1987, p. 51.
<b>f</b>	OJ L 220, 8.8.1987, p. 44.
<b>g</b>	OJ L 225, 10.8.1992, p. 1.
<b>h</b>	OJ L 264, 23.10.1993, p. 49.
<b>i</b>	OJ L 266, 8.11.1995, p. 1.
<b>j</b>	OJ L 169, 8.7.1996, p. 1.
<b>k</b>	OJ L 18, 21.1.1997, p. 7.
<b>l</b>	OJ L 233, 25.8.1997, p. 1.
<b>m</b>	OJ L 91, 25.3.1998, p. 1.
<b>n</b>	OJ L 11, 16.1.1999, p. 25.
<b>o</b>	OJ L 203, 10.8.2000, p. 9.
<b>p</b>	OJ L 291, 8.11.2001, p. 24.
<b>q</b>	OJ L 292, 9.11.2001, p. 21.
<b>r</b>	OJ L 42, 13.2.2002, p. 42.
<b>s</b>	OJ L 18, 21.1.2002, p. 1.
<b>t</b>	OJ L 122, 16.5.2003, p. 36.
<b>u</b>	OJ L 25, 29.1.2004, p. 1.
<b>v</b>	OJ L 321, 6.12.2003, p. 15.
<b>w</b>	OJ L 49, 19.2.2004, p. 36.
<b>x</b>	OJ L 153, 30.4.2004, p. 107.
<b>y</b>	OJ L 337, 13.11.2004, p. 13.
	OJ L 194, 26.7.2005, p. 12.

---

*Status: EU Directives are being published on this site to aid cross referencing from UK legislation. After IP completion day (31 December 2020 11pm) no further amendments will be applied to this version.*

---

## PART B

**Time-limits for transposition into national laws**

<b>Directives</b>	<b>Time-limits for transposition</b>	<b>Date of application</b>
Directive 70/156/EEC	10 August 1971	
Directive 78/315/EEC	30 June 1979	
Directive 78/547/EEC	15 December 1979	
Directive 80/1267/EEC	30 June 1982	
Directive 87/358/EEC	1 October 1988	
Directive 87/403/EEC	1 October 1988	
Directive 92/53/EEC	31 December 1992	1 January 1993
Directive 93/81/EEC	1 October 1993	
Directive 95/54/EC	1 December 1995	
Directive 96/27/EC	20 May 1997	
Directive 96/79/EC	1 April 1997	
Directive 97/27/EC	22 July 1999	
Directive 98/14/EC	30 September 1998	1 October 1998
Directive 98/91/EC	16 January 2000	
Directive 2000/40/EC	31 July 2002	1 August 2002
Directive 2001/92/EC	30 June 2002	
Directive 2001/56/EC	9 May 2003	
Directive 2001/85/EC	13 August 2003	
Directive 2001/116/EC	30 June 2002	1 July 2002
Directive 2003/97/EC <sup>a</sup>	25 January 2005	
Directive 2003/102/EC <sup>b</sup>	31 December 2003	
Directive 2004/3/EC	18 February 2005	
Directive 2004/78/EC	30 September 2004	
Directive 2004/104/EC	31 December 2005	1 January 2006
Directive 2005/49/EC	30 June 2006	1 July 2006

<sup>a</sup> OJ L 25, 29.1.2004, p. 1.

<sup>b</sup> OJ L 321, 6.12.2003, p. 15.

---

---

*Status: EU Directives are being published on this site to aid cross referencing from UK legislation. After IP completion day (31 December 2020 11pm) no further amendments will be applied to this version.*

---

## ANNEX XXI

CORRELATION TABLE  
(referred to in the second paragraph of Article 49)

Directive 70/156/EEC	This Directive
—	Article 1
Article 1, first subparagraph	Article 2(1)
Article 1, second subparagraph	Article 2(2)(a) and (b)
—	Article 2(2)(c)
—	Article 2(3) and (4)
Article 2	Article 3
—	Article 4
—	Article 5
—	Article 6(1)
Article 3(1)	Article 6(2)
Article 3(2)	Article 6(3)
—	Article 6(4)
Article 3(3)	Article 6(5)
Article 3(4)	Article 7(1) and (2)
Article 3(5)	Articles 6(6) and 7(1)
—	Article 6(7) and (8)
—	Article 7(3) and (4)
Article 4(1), first subparagraph, point (a)	Article 9(1)
Article 4(1), first subparagraph, point (b)	Article 9(2)
Article 4(1), first subparagraph, point (c)	Article 10(1)
Article 4(1), first subparagraph, point (d)	Article 10(2)
—	Article 10(3)
Article 4(1), second subparagraph	Article 9(4)
Article 4(1), third subparagraph	Article 9(5)
—	Article 9(6) and (7)
—	Article 8(1) and (2)
Article 4(2)	Article 8(3)
Article 4(3), first and third sentences	Article 9(3)
Article 4(3), second sentence	Article 8(4)
Article 4(4)	Article 10(4)

*Status: EU Directives are being published on this site to aid cross referencing from UK legislation. After IP completion day (31 December 2020 11pm) no further amendments will be applied to this version.*

Article 4(5)	Article 8(5) and (6)
Article 4(6)	Article 8(7) and (8)
—	Article 11
Article 5(1)	Article 13(1)
Article 5(2)	Article 13(2)
Article 5(3), first subparagraph	Article 15(1)
Article 5(3), second subparagraph	Article 15(3)
Article 5(3), third subparagraph	Articles 15(2), 16(1) and 16(2)
Article 5(3), fourth subparagraph	Article 13(3)
Article 5(4), first subparagraph	Article 14(1)
Article 5(4), second subparagraph	Articles 14(3) and 16(2)
Article 5(4), third subparagraph	Article 14(2)
Article 5(4), fourth subparagraph, first sentence	Article 13(3)
Article 5(4), fourth subparagraph, second sentence	Article 16(3)
Article 5(5)	Article 17(4)
Article 5(6)	Article 14(4)
—	Article 17(1) to (3)
Article 6(1), first subparagraph	Article 18(1)
—	Article 18(2)
Article 6(1), second subparagraph	Article 18(3)
Article 6(2)	—
—	Article 18(4) to (8)
Article 6(3)	Article 19(1) and (2)
—	Article 19(3)
Article 6(4)	Article 38(2), first subparagraph
—	Article 38(2), second subparagraph
Article 7(1)	Article 26(1)
—	Article 26(2)
Article 7(2)	Article 28
Article 7(3)	Article 29(1) and (2)
—	Article 29(3) and (4)
Article 8(1)	—
—	Article 22



*Status: EU Directives are being published on this site to aid cross referencing from UK legislation. After IP completion day (31 December 2020 11pm) no further amendments will be applied to this version.*

Article 8(2)(a), first sentence	Article 26(3)
Article 8(2)(a), second sentence	—
Article 8(2)(a), third to sixth sentences	Article 23(1), (3), (5) and (6)
—	Article 23(2)
—	Article 23(4)
—	Article 23(7)
Article 8(2)(b)(1), first and second subparagraphs	Article 27(1)
Article 8(2)(b)(1), third subparagraph	Article 27(2)
Article 8(2)(b)(2), first and second subparagraphs	Article 27(3)
Article 8(2)(b)(2), third and fourth subparagraphs	—
—	Article 27(4) and (5)
Article 8(2)(c), first subparagraph	Article 20(1) and (2)
Article 8(2)(c), second subparagraph	Article 20(4), first subparagraph
Article 8(2)(c), third subparagraph	—
Article 8(2)(c), fourth subparagraph	Article 20(4), second subparagraph
—	Article 20(4), third subparagraph
—	Article 20(3) and (5)
Article 8(2)(c), fifth and sixth subparagraphs	Article 21(1), first subparagraph, and Article 21(2)
—	Article 21(1), second subparagraph
Article 8(3)	Article 23(4), second subparagraph
—	Article 24
—	Article 25
Article 9(1)	Article 36
Article 9(2)	Article 35(1)
—	Article 34
—	Article 35(2)
Article 10(1)	Article 12(1)
Article 10(2)	Article 12(2), first subparagraph, first sentence
—	Article 12(2), first subparagraph, second sentence
—	Article 12(3)

---

*Status: EU Directives are being published on this site to aid cross referencing from UK legislation. After IP completion day (31 December 2020 11pm) no further amendments will be applied to this version.*

---

Article 11(1)	Article 30(2)
Article 11(2)	Article 30(1)
Article 11(3)	Article 30(3)
Article 11(4)	Article 30(4)
Article 11(5)	Article 30(5)
Article 11(6)	Article 30(6)
—	Article 31
—	Article 32
Article 12, first sentence	Article 33(1)
Article 12, second sentence	Article 33(2)
—	Article 37
—	Article 38(1)
Article 13(1)	Article 40(1)
—	Article 39(1)
Article 13(2)	Article 39(2)
Article 13(3)	Article 40(3)
—	Article 40(2)
Article 13(4)	Article 39(7)
Article 13(5)	Article 39(2)
—	Article 39(3) to (6), (8) and (9)
—	Article 41(1) to (3)
Article 14(1), first indent	Article 43(1)
Article 14(1), second indent, first sentence	—
Article 14(1), second indent, second sentence	Article 41(4)
Article 14(1), second indent, point (i)	Article 41(6)
Article 14(1), second indent, point (ii)	—
Article 14(2), first subparagraph	—
—	Article 41(5) and (7)
Article 14(2), second subparagraph	Article 41(8)
—	Article 42
—	Article 43(2) to (5)
—	Articles 44 to 51
Annex I	Annex I
Annex II	Annex II

---

**Status:** EU Directives are being published on this site to aid cross referencing from UK legislation. After IP completion day (31 December 2020 11pm) no further amendments will be applied to this version.

---

Annex III	Annex III
Annex IV	Annex IV
—	Annex IV, Appendix
Annex V	Annex V
Annex VI	Annex VI
—	Annex VI, Appendix
Annex VII	Annex VII
—	Annex VII, Appendix
Annex VIII	Annex VIII
Annex IX	Annex IX
Annex X	Annex X
Annex XI	Annex XI
Annex XII	Annex XII
—	Annex XIII
Annex XIII	Annex XIV
—	Annex XV
—	Annex XVI
Annex XIV	Annex XVII
Annex XV	Annex XVIII
—	Annex XIX
—	Annex XX
—	Annex XXI

---

*Status: EU Directives are being published on this site to aid cross referencing from UK legislation. After IP completion day (31 December 2020 11pm) no further amendments will be applied to this version.*

---

- (1) [OJ C 108, 30.4.2004, p. 29.](#)
- (2) Opinion of the European Parliament of 11 February 2004 ([OJ C 97 E, 22.4.2004, p. 370](#)), Council Common Position of 11 December 2006 ([OJ C 64 E, 20.3.2007, p. 1](#)), Position of the European Parliament of 10 May 2007 (not yet published in the Official Journal) and Council Decision of 23 July 2007.
- (3) [OJ L 42, 23.2.1970, p. 1.](#) Directive as last amended by Regulation (EC) No 715/2007 of the European Parliament and of the Council ([OJ L 171, 29.6.2007, p. 1](#)).
- (4) [OJ L 225, 10.8.1992, p. 1.](#)
- (5) [OJ L 184, 17.7.1999, p. 23.](#) Decision as amended by Decision 2006/512/EC ([OJ L 200, 22.7.2006, p. 11](#)).
- (6) [OJ L 346, 17.12.1997, p. 78.](#)
- (7) [OJ L 11, 15.1.2002, p. 4.](#)
- (8) [OJ L 171, 29.6.2007, p. 1.](#)
- (9) [OJ C 321, 31.12.2003, p. 1.](#)
- (10) [OJ L 171, 9.7.2003, p. 1.](#) Directive as last amended by Council Directive 2006/96/EC ([OJ L 363, 20.12.2006, p. 81](#)).
- (11) [OJ L 124, 9.5.2002, p. 1.](#) Directive as last amended by Council Directive 2006/96/EC.
- (12) [OJ L 157, 9.6.2006, p. 24.](#)
- (13) [OJ L 138, 1.6.1999, p. 57.](#) Directive as last amended by Directive 2006/103/EC ([OJ L 363, 20.12.2006, p. 344](#)).
- (14) [<sup>F1</sup>]<sup>F2</sup>If a part has been type-approved, that part need not be described if reference is made to such approval. Similarly, a part need not be described if its construction is clearly apparent from the attached diagrams or drawings. For each item for which drawings or photographs shall be attached, give numbers of the corresponding attached documents.]
- (15) [<sup>F2</sup>If the means of identification of type contains characters not relevant to describe the vehicle, component or separate technical unit types covered by this information document, such characters shall be represented in the documentation by the symbol ‘?’ (e.g. ABC??123??).]
- (16) Classified according to the definitions set out in Part A of Annex II.
- (17) Designation according to EN 10027-1: 2005. If that is not possible, the following information shall be provided:
  - description of the material,
  - yield point,
  - ultimate tensile stress,
  - elongation (in %),
  - Brinell hardness.
- (18) ‘Forward control’ as defined in point 2.7 of Annex I to Council Directive 74/297/EEC ([OJ L 165, 20.6.1974, p. 16](#)).
- (19) Delete where not applicable (there are cases where nothing needs to be deleted when more than one entry is applicable).
- (20) [<sup>F3</sup>Where there is one version with a normal cab and another with a sleeper cab, both sets of masses and dimensions are to be stated.
- (21) Standard ISO 612: 1978 — Road vehicles — Dimensions of motor vehicles and towed vehicles — terms and definitions.
- (22) Optional equipment that affects the dimensions of the vehicle shall be specified.]
- (23)
  - (<sup>g1</sup>) Motor vehicle and drawbar trailer: term No 6.4.1.
  - Semi-trailer and centre-axle trailer: term No 6.4.2.

*Note:*  
In the case of a centre-axle trailer, the axis of the coupling shall be considered as the foremost axle.

---

*Status: EU Directives are being published on this site to aid cross referencing from UK legislation. After IP completion day (31 December 2020 11pm) no further amendments will be applied to this version.*

---

- (24) <sup>(g2)</sup> Term No 6.19.2.
- (25) <sup>(g3)</sup> Term No 6.20.
- (26) <sup>(g4)</sup> Term No 6.5.
- (27) <sup>(g5)</sup> Term No 6.1 and for vehicles other than those of category M1: point 2.4.1 of Annex I to Directive 97/27/EC of the European Parliament and of the Council (OJ L 233, 25.8.1997, p. 1).  
In the case of trailers, the lengths shall be specified as mentioned in term No 6.1.2 of Standard ISO 612: 1978.
- (28) <sup>(g6)</sup> Term No 6.17.
- (29) <sup>(g7)</sup> Term No 6.2 and for vehicles other than those of category M1: point 2.4.2 of Annex I to Directive 97/27/EC.
- (30) <sup>(g8)</sup> Term No 6.3 and for vehicles other than those of category M1: point 2.4.3 of Annex I to Directive 97/27/EC.
- (31) <sup>(g9)</sup> Term No 6.6.
- (32) <sup>(g10)</sup> Term No 6.10.
- (33) <sup>(g11)</sup> Term No 6.7.
- (34) <sup>(g12)</sup> Term No 6.11.
- (35) <sup>(g13)</sup> Term No 6.18.1.
- (36) <sup>(g14)</sup> Term No 6.9.
- (37) <sup>[F3]</sup>The mass of the driver is assessed at 75 kg.  
The liquid containing systems (except those for used water that must remain empty) are filled to 100 % of the capacity specified by the manufacturer.  
The information referred to in points 2.6(b) and 2.6.1(b) do not need to be provided for vehicle categories N<sub>2</sub>, N<sub>3</sub>, M<sub>2</sub>, M<sub>3</sub>, O<sub>3</sub>, and O<sub>4</sub>.]
- (38) <sup>[F4]</sup>[OJ L 353, 21.12.2012, p. 31.](#)]
- (39) For trailers or semi-trailers, and for vehicles coupled with a trailer or a semi-trailer, which exert a significant vertical load on the coupling device or the fifth wheel, this load, divided by standard acceleration of gravity, is included in the maximum technically permissible mass.
- (40) Please fill in here the upper and lower values for each variant.
- (41) ‘Coupling overhang’ is the horizontal distance between the coupling for centre-axle trailers and the centreline of the rear axle(s).
- (42) Only for the purpose of definition of off-road vehicles.
- (43) In the case of a vehicle that can run either on petrol, diesel, etc., or also in combination with another fuel, items shall be repeated.  
In the case of non-conventional engines and systems, particulars equivalent to those referred to here shall be supplied by the manufacturer.
- (44) <sup>[F7]</sup>In case of a dual-fuel engine or vehicle.]

---

*Status: EU Directives are being published on this site to aid cross referencing from UK legislation. After IP completion day (31 December 2020 11pm) no further amendments will be applied to this version.*

---

- (45) This figure shall be rounded off to the nearest tenth of a millimetre.
- (46) This value shall be calculated ( $\pi = 3,1416$ ) and rounded off to the nearest  $\text{cm}^3$ .
- (47) Specify the tolerance.
- (48) Determined in accordance with the requirements of Regulation (EC) No 715/2007 or Regulation (EC) No 595/2009 as applicable.
- (49) [<sup>F6</sup>Vehicles can be fuelled with both petrol and a gaseous fuel but, where the petrol system is fitted for emergency purposes or starting only and of which the petrol tank cannot contain more than 15 litres of petrol, will be regarded for the test as vehicles which can only run a gaseous fuel.]
- (50) [<sup>F8</sup>[<sup>F6</sup>To be documented in case of a single OBD engine family and if not already included in the documentation package(s) referred to in point 3.2.12.2.7.0.4.]]
- (51) [<sup>F7</sup>To be documented if not already included in the documentation referred to in point 3.2.12.2.7.0.5.]
- (52) Determined in accordance with the requirements of Council Directive 80/1268/EEC (OJ L 375, 31.12.1980, p. 36).
- (53) [<sup>F8</sup>[<sup>F6</sup>Except for dual-fuel engines or vehicles.
- (54) In the case of Type 1B, Type 2B, and Type 3B of dual-fuel engines.]
- (55) [<sup>F7</sup>Value for the combined WHTC including cold and hot part in accordance with Annex VIII to Regulation (EU) No 582/2011.]]
- (56) [<sup>F12</sup>(<sup>w1</sup>) Expand the table if necessary, using one extra row per eco-innovation.
- (57) The specified particulars are to be given for any proposed variants.
- (58) With respect to trailers, maximum speed permitted by the manufacturer.
- (59) For tyres of category Z intended to be fitted on vehicles whose maximum speed exceeds 300 km/h equivalent information shall be provided.
- (60) The number of seating positions to be mentioned shall be the one when the vehicle is in motion. A range can be specified in case of modular arrangement.
- (61) ‘R-point’ or ‘seating reference point’ means a design point defined by the vehicle manufacturer for each seating position and established with respect to the three-dimensional reference system as specified in Annex III to Council Directive 77/649/EEC (OJ L 267, 19.10.1977, p. 1).
- (62) For symbols and marks to be used, see Annex III, items 1.1.3 and 1.1.4 to Council Directive 77/541/EEC (OJ L 220, 29.8.1977, p. 95). In the case of ‘S’ type belts, specify the nature of the type(s).
- (63) These terms are defined in the standard ISO 22628: 2002 — Road vehicles — recyclability and recoverability — calculation method.]
- (64) [<sup>F16</sup>OJ L 42, 13.2.2002, p. 1.
- (65) OJ L 39, 15.2.1980 p. 40.
- (66) OJ L 140, 5.6.2009, p. 1.
- (67) OJ L 200, 31.7.2009, p. 1.]
- (68) [<sup>F1</sup>[<sup>F25</sup>In the absence of a registration document, the competent authority may refer to available documented evidence of date of manufacture or documented evidence of first purchase.]
- (69) OJ L 346, 17.12.1997, p. 78.
- (70) For subsequent amendments, see UNECE TRANS/WP.29/343 in its latest revision.]
- (71) [<sup>F27</sup>OJ L 24, 30.1.1976, p. 1.]
- (72) [<sup>F1</sup>If not available at the time of granting the type-approval, this item shall be completed at the latest when the vehicle is introduced on the market.
- (73) As defined in Annex II.A.

---

*Status: EU Directives are being published on this site to aid cross referencing from UK legislation. After IP completion day (31 December 2020 11pm) no further amendments will be applied to this version.*

---

- (74) See side 2.
- (75) If the means of identification of type contains characters not relevant to describe the vehicle, component or separate technical unit types covered by this information document, such characters shall be represented in the documentation by the symbol ‘?’ (e.g. ABC??123??).
- (76) As defined in Annex II, Section A.
- (77) If the means of identification of type contains characters not relevant to describe the vehicle, component or separate technical unit types covered by this information document, such characters shall be represented in the documentation by the symbol ‘?’ (e.g.. ABC??123??).
- (78) [<sup>F25</sup>As defined in Annex II.A
- (79) Delete where not applicable.
- (80) One  $\frac{3}{4}$  front, one  $\frac{3}{4}$  rear
- (81) This entry shall be completed only where the vehicle has two axles.
- (82) This mass is the actual mass of the vehicle in the conditions referred to in point 2.6 of Annex I.
- (83) Delete where not applicable
- (84) For hybrid electric vehicles, indicate both power outputs.
- (85) The codes described in Section C of Annex II shall be used.
- (86) Indicate only the basic colour(s): white, yellow, orange, red, violet, blue, green, grey, brown or black.
- (87) Excluding seats designated for use only when the vehicle is stationary and the number of wheelchair positions.
- (88) Add the number of the Euro level and, if appropriate, the character corresponding to the provisions used for type-approval.
- (89) Repeat for the various fuels which can be used.
- (90) Not compulsory]]
- (91) [<sup>F1</sup>Components and separate technical units shall be marked in accordance with the provisions of the relevant regulatory acts.
- (92) [<sup>F22</sup>Commission Regulation (EU) No 1008/2010 of 9 November 2010 concerning type-approval requirements for windscreen wiper and washer systems of certain motor vehicles and implementing Regulation (EC) No 661/2009 of the European Parliament and of the Council concerning type-approval requirements for the general safety of motor vehicles, their trailers and systems, components and separate technical units intended therefor (OJ L 292, 10.11.2010, p. 2).
- (93) Commission Regulation (EU) No 19/2011 of 11 January 2011 concerning type-approval requirements for the manufacturer's statutory plate and for the vehicle identification number of motor vehicles and their trailers and implementing Regulation (EC) No 661/2009 of the European Parliament and of the Council concerning type-approval requirements for the general safety of motor vehicles, their trailers and systems, components and separate technical units intended therefor (OJ L 8, 12.1.2011, p. 1).
- (94) Commission Regulation (EU) No 249/2012 of 21 March 2012 amending Regulation (EU) No 19/2011 as regards type-approval requirements for the manufacturer's statutory plate of motor vehicles and their trailers (OJ L 82, 22.3.2012, p. 1).]]
- (95) [<sup>F36</sup>When restrictions for the fuel are applicable, indicate these restrictions (e.g. for natural gas the L range or the H range).
- (96) For bi fuel vehicles, the table shall be repeated for both fuels.
- (97) For flex fuel vehicles, when the test is to be performed on both fuels, according to Figure I.2.4 of Annex I to Regulation (EC) No 692/2008, and for vehicles running on LPG or NG/Biomethane, either bi-fuel or mono-fuel, the table shall be repeated for the different reference gases used in the test, and an additional table shall display the worst results obtained. When applicable, in accordance with sections 1.1.2.4 and 1.1.2.5 of Annex I to Regulation (EC) No 692/2008, it shall be shown if the results are measured or calculated.

---

*Status: EU Directives are being published on this site to aid cross referencing from UK legislation. After IP completion day (31 December 2020 11pm) no further amendments will be applied to this version.*

---

- (98) Delete where not applicable.
- (99) If applicable.
- (100) For Euro VI, ESC shall be understood as WHSC and ETC as WHTC.
- (101) For Euro VI, if CNG and LPG fuelled engines are tested on different reference fuels, the table shall be reproduced for each reference fuel tested.
- (102) Repeat the table for each reference fuel tested.
- (103)<sup>(h1)</sup> Repeat the table for each variant/version.
- (104)<sup>(h2)</sup> Repeat the table for each reference fuel tested
- (105)<sup>(h3)</sup> Expand the table if necessary, using one extra row per eco-innovation.
- (106)<sup>(h8)</sup> The general code of the eco-innovation(s) shall consist of the following elements each separated by a blank space:
- Code of the approval authority as set out in Annex VII;
  - Individual code of each eco-innovation fitted in the vehicle, indicated in chronological order of the Commission approval decisions.  
(E.g. the general code of three eco-innovations approved chronologically as 10, 15 and 16 and fitted to a vehicle certified by the German type-approval authority should be: ‘e1 10 15 16’.)]
- (107) Only where the value has changed during the current stage of approval.

#### Textual Amendments

- F1** Substituted by Commission Regulation (EC) No 1060/2008 of 7 October 2008 replacing Annexes I, III, IV, VI, VII, XI and XV to Directive 2007/46/EC of the European Parliament and of the Council establishing a framework for the approval of motor vehicles and their trailers, and of systems, components and separate technical units intended for such vehicles (Framework Directive) (Text with EEA relevance).
- F2** Substituted by Commission Regulation (EU) 2015/166 of 3 February 2015 supplementing and amending Regulation (EC) No 661/2009 of the European Parliament and of the Council as regards the inclusion of specific procedures, assessment methods and technical requirements, and amending Directive 2007/46/EC of the European Parliament and of the Council, and Commission Regulations (EU) No 1003/2010, (EU) No 109/2011 and (EU) No 458/2011 (Text with EEA relevance).
- F3** Substituted by Commission Regulation (EU) No 1230/2012 of 12 December 2012 implementing Regulation (EC) No 661/2009 of the European Parliament and of the Council with regard to type-approval requirements for masses and dimensions of motor vehicles and their trailers and amending Directive 2007/46/EC of the European Parliament and of the Council (Text with EEA relevance).
- F4** Inserted by Commission Regulation (EU) No 1230/2012 of 12 December 2012 implementing Regulation (EC) No 661/2009 of the European Parliament and of the Council with regard to type-approval requirements for masses and dimensions of motor vehicles and their trailers and amending Directive 2007/46/EC of the European Parliament and of the Council (Text with EEA relevance).
- F6** Substituted by Commission Regulation (EU) No 133/2014 of 31 January 2014 amending, for the purposes of adapting to technical progress as regards emission limits, Directive 2007/46/EC of the European Parliament and of the Council, Regulation (EC) No 595/2009 of the European Parliament and of the Council and Commission Regulation (EU) No 582/2011 (Text with EEA relevance).
- F7** Inserted by Commission Regulation (EU) No 133/2014 of 31 January 2014 amending, for the purposes of adapting to technical progress as regards emission limits, Directive 2007/46/EC of the European Parliament and of the Council, Regulation (EC) No 595/2009 of the European Parliament and of the Council and Commission Regulation (EU) No 582/2011 (Text with EEA relevance).



---

*Status: EU Directives are being published on this site to aid cross referencing from UK legislation. After IP completion day (31 December 2020 11pm) no further amendments will be applied to this version.*

---

- F8** Inserted by Commission Regulation (EU) No 582/2011 of 25 May 2011 implementing and amending Regulation (EC) No 595/2009 of the European Parliament and of the Council with respect to emissions from heavy duty vehicles (Euro VI) and amending Annexes I and III to Directive 2007/46/EC of the European Parliament and of the Council (Text with EEA relevance).
- F12** Inserted by Commission Regulation (EU) No 195/2013 of 7 March 2013 amending Directive 2007/46/EC of the European Parliament and of the Council and Commission Regulation (EC) No 692/2008 as concerns innovative technologies for reducing CO<sub>2</sub> emissions from light passenger and commercial vehicles (Text with EEA relevance).
- F16** Substituted by Commission Regulation (EU) No 678/2011 of 14 July 2011 replacing Annex II and amending Annexes IV, IX and XI to Directive 2007/46/EC of the European Parliament and of the Council establishing a framework for the approval of motor vehicles and their trailers, and of systems, components and separate technical units intended for such vehicles (Framework Directive) (Text with EEA relevance).
- F22** Inserted by Commission Regulation (EU) 2015/166 of 3 February 2015 supplementing and amending Regulation (EC) No 661/2009 of the European Parliament and of the Council as regards the inclusion of specific procedures, assessment methods and technical requirements, and amending Directive 2007/46/EC of the European Parliament and of the Council, and Commission Regulations (EU) No 1003/2010, (EU) No 109/2011 and (EU) No 458/2011 (Text with EEA relevance).
- F25** Inserted by Commission Regulation (EU) No 183/2011 of 22 February 2011 amending Annexes IV and VI to Directive 2007/46/EC of the European Parliament and of the Council establishing a framework for the approval of motor vehicles and their trailers and of systems, components and separate technical units intended for such vehicles (Framework Directive) (Text with EEA relevance).
- F27** Substituted by Commission Regulation (EU) No 371/2010 of 16 April 2010 replacing Annexes V, X, XV and XVI to Directive 2007/46/EC of the European Parliament and of the Council establishing a framework for the approval of motor vehicles and their trailers, and of systems, components and separate technical units intended for such vehicles (Framework Directive) (Text with EEA relevance).
- F36** Substituted by Commission Regulation (EU) No 195/2013 of 7 March 2013 amending Directive 2007/46/EC of the European Parliament and of the Council and Commission Regulation (EC) No 692/2008 as concerns innovative technologies for reducing CO<sub>2</sub> emissions from light passenger and commercial vehicles (Text with EEA relevance).