

This document is meant purely as a documentation tool and the institutions do not assume any liability for its contents

► B

COMMISSION DIRECTIVE 2008/126/EC

of 19 December 2008

amending Directive 2006/87/EC of the European Parliament and of the Council laying down technical requirements for inland waterway vessels

(OJ L 32, 31.1.2009, p. 1)

Amended by:

		Official Journal		
		No	page	date
► <u>M1</u>	Commission Directive 2009/56/EC of 12 June 2009	L 150	5	13.6.2009



COMMISSION DIRECTIVE 2008/126/EC

of 19 December 2008

amending Directive 2006/87/EC of the European Parliament and of the Council laying down technical requirements for inland waterway vessels

THE COMMISSION OF THE EUROPEAN COMMUNITIES,

Having regard to the Treaty establishing the European Community,

Having regard to Directive 2006/87/EC of the European Parliament and of the Council of 12 December 2006 laying down technical requirements for inland waterway vessels and repealing Council Directive 82/714/EEC ⁽¹⁾, and in particular Article 20(1) thereof,

Whereas:

- (1) Binding administrative instructions for the inspection have been adopted pursuant to Article 22 of the Revised Convention for Rhine Navigation. It is therefore necessary to amend Directive 2006/87/EC accordingly.
- (2) It should be ensured that the Community vessel certificate and the vessel certificate delivered in accordance with the Rhine Vessel Inspection Regulation are issued on the basis of technical requirements which guarantee an equivalent level of safety.
- (3) In order to avoid distortions of competition as well as different levels of safety, the amendments to Directive 2006/87/EC should be implemented as quickly as possible.
- (4) The measure provided for in this Directive are in accordance with the opinion of the Committee established under Article 7 of Council Directive 91/672/EEC of 16 December 1991 on the reciprocal recognition of national boatmasters' certificates for the carriage of goods and passengers by inland waterway ⁽²⁾,

HAS ADOPTED THIS DIRECTIVE:

Article 1

Appendix II to Annex II to Directive 2006/87/EC is amended as set out in the Annex to this Directive.

Article 2

Member States which have inland waterways as referred to in Article 1(1) of Directive 2006/87/EC shall bring into force the laws, regulations and administrative provisions necessary to comply with this Directive with effect from ►**M1** 30 June 2009 ◀. They shall forthwith communicate to the Commission the text of those provisions.

When Member States adopt those provisions, they shall contain a reference to this Directive or be accompanied by such a reference on the occasion of their official publication. Member States shall determine how such reference is to be made.

Article 3

This Directive shall enter into force on the day of its publication in the *Official Journal of the European Union*.

⁽¹⁾ OJ L 389, 30.12.2006, p. 1.

⁽²⁾ OJ L 373, 31.12.1991, p. 29.

▼B

Article 4

This Directive is addressed to the Member States which have inland waterways as referred to in Article 1(1) of Directive 2006/87/EC.

▼B*ANNEX*

Appendix II to Annex II to Directive 2006/87/EC is replaced by the following:

*'Appendix II***Administrative instructions**

- No 1: Requirements relating to the capacity for taking evasive action and turning capacity
- No 2: Requirements concerning prescribed (forward) speed, stopping capacity and capacity for going astern
- No 3: Requirements for coupling systems and coupling devices for craft suitable for propelling or being propelled in a rigid assembly
- No 4: Left void
- No 5: Noise measurements
- No 6: Left void
- No 7: Special anchors with reduced mass
- No 8: Strength of watertight windows
- No 9: Requirements for automatic pressurised water sprinklers
- No 10: Left void
- No 11: Completion of the Community Certificate
- No 12: Fuel tanks on floating equipment
- No 13: Minimum hull thickness of barges
- No 14: Left void
- No 15: Steerageway under vessel's own power
- No 16: Left void
- No 17: Appropriate fire alarm system
- No 18: Proof of buoyancy, trim and stability of the separated parts of a vessel
- No 19: Left void
- No 20: Equipment for vessels to be operated according to standards S1 and S2
- No 21: Requirements for low-location lighting
- No 22: Specific safety needs of persons with reduced mobility
- No 23: Left void
- No 24: Suitable gas warning equipment
- No 25: Electrical cables

Note:

In accordance with Article 5(7) of the Directive, for subjects covered by Annex IV, each Member State may allow less stringent requirements for the respective values indicated in the following Administrative instructions for craft operating exclusively on Zone 3 and Zone 4 waterways within its territory.

In accordance with Article 5(1) and (3) of the Directive, for subjects covered by Annex III, each Member State may adopt more stringent requirements for the respective values indicated in the following Administrative instructions for craft operating on Zone 1 and Zone 2 waterways within its territory.



ADMINISTRATIVE INSTRUCTION No 1

Requirements relating to the capacity for taking evasive action and turning capacity

(Articles 5.09 and 5.10 in conjunction with Articles 5.02(1), 5.03(1), 5.04 and 16.06 of Annex II)

1. General conditions and boundary conditions relating to the evasive action test

- 1.1. According to Article 5.09, vessels and convoys shall be able to take evasive action in good time and the capacity for such action shall be proved by evasive action manoeuvres in the test area in accordance with Article 5.03. This shall be proved by simulated evasive action manoeuvres to port and starboard with prescribed values whereby for specific turning speeds of the vessel in response to putting across and then checking the helm a certain time limit shall be complied with.

During tests the requirements of Section 2 shall be complied with keeping a keel clearance of at least 20 % of the draught, but not less than 0,50 m.

2. Evasive action test procedure and recording of data

(Diagram in Annex 1)

- 2.1. Evasive action manoeuvres shall be performed as follows:

With the vessel or convoy under way at a constant speed of $V_0 = 13$ km/h in relation to the water, at the start of the manoeuvre (time $t_0 = 0$ s, turning speed $r = 0^\circ/\text{min}$, rudder angle $\delta_0 = 0^\circ$, engine speed kept constant), evasive action to port or starboard is to be initiated by putting across the helm. The rudder shall be set to an angle δ , or the steering unit to an angle δ_a in the case of an active steering device, at the start of the manoeuvre, in accordance with the indications given in point 2.3. The rudder angle δ (e.g. 20° to starboard) shall be maintained until the value r_1 of the turning speed referred to in point 2.2 for the corresponding dimensions of the vessel or convoy is reached. When the turning speed r_1 is reached, the time t_1 shall be recorded and the rudder set to the same angle on the opposite side (e.g. 20° to port) so as to stop the turn and commence turning in the opposite direction, i.e., to reduce the turning speed to $r_2 = 0$ and let it to rise again to the value given in point 2.2. When the turning speed $r_2 = 0$ is reached, the time t_2 shall be recorded. When the turning speed r_3 given in point 2.2 is reached, the rudder shall be set in the opposite direction to the same angle δ , so as to stop the turning movement. The time t_3 shall be recorded. When the turning speed $r_4 = 0$ is reached, the time t_4 shall be recorded and the vessel or convoy shall be returned to its original course.

- 2.2. The following limit values shall be complied with to reach turning speed r_4 depending on the dimensions of the vessels or the convoys and on the water depth h :

	Dimensions of vessels or convoys $L \times B$	Required turning speed $r_1 = r_3$ ($^\circ/\text{min}$)		Limit values for the time t_4 (s) in shallow and deep water		
		$\delta = 20^\circ$	$\delta = 45^\circ$	$1,2 \leq h/T \leq 1,4$	$1,4 < h/T < 2$	$h/T > 2$
1	All motor vessels; single-in-line convoys $\leq 110 \times 11,45$	$20^\circ/\text{min}$	$28^\circ/\text{min}$	150 s	110 s	110 s
2	Single-in-line convoys up to $193 \times 11,45$ or two-abreast convoys up to $110 \times 22,90$	$12^\circ/\text{min}$	$18^\circ/\text{min}$	180 s	130 s	110 s
3	Two-abreast convoys $\leq 193 \times 22,90$	$8^\circ/\text{min}$	$12^\circ/\text{min}$	180 s	130 s	110 s

▼B

	Dimensions of vessels or convoys L × B	Required turning speed $r_1 = r_3$ (°/min)		Limit values for the time t_4 (s) in shallow and deep water		
		$\delta = 20^\circ$	$\delta = 45^\circ$	$1,2 \leq h/T \leq 1,4$	$1,4 < h/T < 2$	$h/T > 2$
4	Two-abreast convoys up to $270 \times 22,90$ or three-abreast convoys up to $193 \times 34,35$	6°/min	8°/min	(*)	(*)	(*)

(*) In accordance with the decision of the nautical expert.

The times t_1 , t_2 , t_3 and t_4 required to reach turning speeds r_1 , r_2 , r_3 and r_4 shall be recorded in the measurements report in Annex 2. The t_4 values shall not exceed the limits given in the table.

2.3. At least four evasive action manoeuvres shall be carried out, namely:

- one to starboard with a rudder angle $\delta = 20^\circ$
- one to port with a rudder angle $\delta = 20^\circ$
- one to starboard with a rudder angle $\delta = 45^\circ$
- one to port with a rudder angle $\delta = 45^\circ$.

If necessary (e.g. in the case of uncertainty about the values measured or of unsatisfactory manoeuvres), the evasive action manoeuvres shall be repeated. The turning speeds given in point 2.2 and the time limits shall be complied with. For active steering devices or special types of rudder, a position δ_a of the steering unit or rudder angle δ_a other than $\delta = 20^\circ$ and $\delta = 45^\circ$ may be selected, according to the expert's assessment, depending on the type of steering system.

2.4. In order to determine the turning speed, a rate-of-turn indicator in accordance with Annex IX to the Directive shall be on board.

2.5. In accordance with Article 5.04, the load condition during the evasive action manoeuvre shall be between 70 % and 100 % of the maximum deadweight. If the test is carried out with a smaller load, approval for downstream and upstream navigation shall be restricted to that load limit.

The procedure for evasive action manoeuvres and the terms used are shown in a diagram in Annex 1.

3. Turning capacity

The turning capacity of vessels and convoys whose length (L) does not exceed 86 m and width (B) does not exceed 22,90 m shall be considered sufficient under Article 5.10, in conjunction with Article 5.02(1) when during an upstream turning manoeuvre with an initial speed in relation to the water of 13 km/h, the limit values for stopping facing downstream established in Administrative instruction No 2 are complied with. The keel clearance conditions according to Section 1.1 shall be complied with.

4. Other requirements

4.1. Notwithstanding points 1 to 3, the following requirements shall be met:

- (a) for manually controlled steering systems, a single turn of the wheel shall correspond to a rudder angle of at least 3° ;
- (b) for powered steering systems, when the rudder is at maximum immersion, it shall be possible to achieve an average angular velocity of $4^\circ/\text{s}$ over the rudder's entire turning range.

This requirement shall also be checked, with the vessel at full speed, for moving the rudder over a range from 35° port to 35° starboard. In addition, it shall be checked whether the rudder keeps the position of maximum angle at maximum propulsion power. For active steering systems or special types of rudder, this provision applies *mutatis mutandis*.

▼B

- 4.2. If any of the additional equipment referred to in Article 5.05 is needed in order to reach the required manoeuvring capacities, it shall comply with the requirements of chapter 6, and the following particulars shall be entered under item 52 of the Community Certificate:

“Flanking rudders (*)/bow steering systems (*)/other equipment (*) referred to under item 34 is (*)/are (*) necessary to comply with the manoeuvrability requirements of chapter 5.

(*) Delete as appropriate.”

5. **Recording of data and reports**

The measurements, reports and recording of data shall be carried out according to the procedure set out in Annex 2.

▼ **B**

ANNEX 1

to Administrative instruction No 1

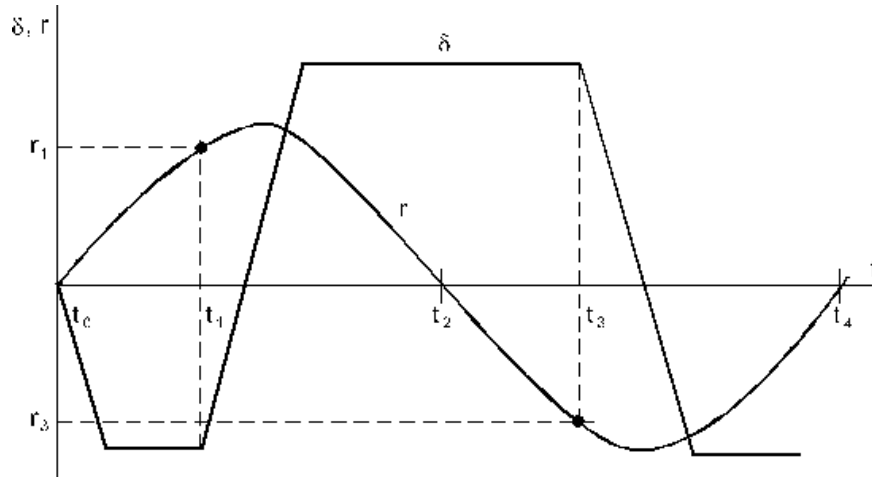
Diagram of the evasive action manoeuvre

t_0 = Start of evasive action manoeuvre

t_1 = Time to reach turning speed r_1

t_2 = Time to reach turning speed $r_2 = 0$

t_3 = Time to reach turning speed r_3

t_4 = Time to reach turning speed $r_4 = 0$ (end of evasive action manoeuvre)

$\hat{\delta}$ = Rudder angle [°]

r = Turning speed [°/min]

▼B

ANNEX 2

to Administrative instruction No 1

Report on evasive action manoeuvre and turning capacity

Inspection body:

Date:

Name:

Name of craft:

Owner:

Type of craft: Test area:

or convoy: Relevant water level [m]:

L × B [m × m]: Depth of water h [m]:

T_{test} [m]: h/T:

Speed of the current [m/s]:

Load: % of maximum

(during test) [t]: deadweight:

Rate-of turn indicator

Type:

Type of rudder construction: normal construction/special construction (*)

Active steering system: yes/no (*)

Results of evasive action manoeuvres:

Time t ₁ to t ₄ required for the evasive action	Rudder angle δ or δ _a (*) at which evasive action commences and turning speed to be complied with r ₁ = r ₃				Comments
	δ = 20° STAR (*)	δ = 20° PORT (*)	δ = 45° STAR (*)	δ = 45° PORT (*)	
	δ _a = ... STAR (*)	δ _a = ... PORT (*)	δ _a = ... STAR (*)	δ _a = ... PORT (*)	
	r ₁ = r ₃ = ... °/min		r ₁ = r ₃ = ... °/min		
t ₁ [s]					
t ₂ [s]					
t ₃ [s]					
t ₄ [s]					
Limit value t ₄ according to 2.2	Limit value t ₄ = ... [s]				

Turning capacity (*)

Geographic position at start of turning manoeuvre km

Geographic position at end of turning manoeuvre km

(*) Delete as appropriate.

▼ B

Steering apparatus

Type of operation: manual/powered (*)

Rudder angle for each turn of the wheel (*): °

Angular velocity of the rudder over the whole range (*): °/s

Angular velocity of the rudder over the range 35° Port to 35° Starboard (*): °/s

(*) Delete as appropriate.



ADMINISTRATIVE INSTRUCTION No 2

Requirements concerning prescribed (forward) speed, stopping capacity and capacity for going astern

(Articles 5.06, 5.07 and 5.08 in conjunction with Articles 5.02(1), 5.03(1), 5.04 and 16.06 of Annex II)

1. Maximum prescribed (forward) speed in accordance with Article 5.06

The speed in relation to the water is satisfactory in accordance with Article 5.06(1) when it reaches at least 13 km/h. During tests, the following conditions shall be met in the same way as for the stopping test:

- (a) the keel clearance set out in point 2.1 shall be complied with;
- (b) the measuring, recording, registration and evaluation of test data shall be carried out.

2. Stopping capacity and capacity for going astern prescribed in accordance with Articles 5.07 and 5.08

2.1. Vessels and convoys are deemed able to stop facing downstream in good time in accordance with Article 5.07(1) when this is proved during a test of stopping in relation to the ground facing downstream at an initial speed in relation to the water of 13 km/h, with a keel clearance equal to at least 20 % of the draught but not less than 0,50 m.

- (a) In flowing water (current velocity of 1,5 m/s), stopping in relation to the water shall be demonstrated over a maximum distance measured in relation to the ground of:

550 m for vessels and convoys of:

- length $L > 110$ m or
- width $B > 11,45$ m,

or

480 m for vessels and convoys of:

- length $L \leq 110$ m and
- width $B \leq 11,45$ m.

The stopping manoeuvre is completed on coming to a stop in relation to the ground.

- (b) In standing water (current velocity of less than 0,2 m/s), stopping in relation to the water shall be demonstrated over a maximum distance, measured in relation to the ground of:

350 m for vessels and convoys of:

- length $L > 110$ m or
- width $B > 11,45$ m,

or

305 m for vessels and convoys of:

- length $L \leq 110$ m and
- width $B \leq 11,45$ m.

In standing water, a test shall also be performed to demonstrate that a speed of not less than 6,5 km/h can be reached when going astern.

The measuring, recording and registration of the test data referred to in (a) or (b) shall be carried out in accordance with the procedure set out in Appendix 1.

Throughout the entire test, the vessel or the convoy shall have adequate manoeuvrability.

▼B

- 2.2. In accordance with Article 5.04, during the test, vessels shall be loaded as far as possible to 70-100 % of their deadweight. This load condition shall be evaluated in accordance with Appendix 2. When the vessel or the convoy is loaded to less than 70 % at the time of the test, the permitted maximum displacement in downstream navigation shall be set in accordance with the actual load, provided that the limit values of point 2.1 are complied with.
- 2.3. If the actual values of the initial speed and current velocity at the time of the test do not meet the conditions set out in point 2.1, the results obtained shall be evaluated according to the procedure described in Appendix 2.

The permitted deviation of the initial speed of 13 km/h shall be not more than +1 km/h, and the current velocity in flowing water shall be between 1,3 and 2,2 m/s, otherwise the tests shall be repeated.
- 2.4. The permitted maximum displacement or the respective maximum load or the maximum immersed cross-section for vessels and convoys in downstream navigation shall be determined on the basis of the tests and entered in the Community Certificate.



Appendix 1

to Administrative instruction No 2

MEASURING, RECORDING AND REGISTRATION OF DATA COLLECTED DURING STOPPING MANOEUVRE TESTS

1. Stopping manoeuvre

The vessels and convoys referred to in Chapter 5 shall carry out a test in flowing water or in standing water, in a test area, to prove that they are capable of stopping facing downstream only with their propulsion system without the use of anchors. The stopping manoeuvre shall, in principle, be carried out in accordance with figure 1. It begins when the vessel is travelling at a constant speed of as near as possible to 13 km/h in relation to the water by reversing the engines from “ahead” to “astern” (point **A** of the order “stop”) and is completed when the vessel is stationary in relation to the ground (point **E**: $v = 0$ in relation to the ground or point **D**: $v = 0$ in relation to the water and in relation to the ground if the stopping manoeuvre is carried out in standing water).

When stopping manoeuvres are carried out in flowing water, the position and the moment of stopping in relation to the water shall also be recorded (the vessel moves at the speed of the current; point **D**: $v = 0$ in relation to the water).

The data measured shall be entered in a report as shown in the diagram of table 1. Before the stopping manoeuvre is carried out, the unchanging data shall be entered at the top of the form.

The average current velocity (v_{STR}) in the fairway shall be determined, if available, based on the reading of an established water level gauge, or by measuring the movement of a floating body and shall be entered in the report.

In principle, the use of current metres is permitted to determine the speed of the vessel in relation to the water during the stopping manoeuvre, if it is possible to record the movement and the required data in accordance with the procedure above.

2. Registration of the data measured and recording them in the report (table 1)

For the stopping manoeuvre, first of all the initial speed in relation to the water shall be determined. This can be done by measuring the time taken to travel between two markers on land. In flowing water, the average current velocity shall be taken into account.

The stopping manoeuvre is initiated by the order “stop”**A**, given on passing a marker on land. Passing the land marker shall be recorded perpendicularly to the axis of the vessel and shall be entered in the report. Passing all other land markers during the stopping manoeuvre shall be similarly recorded and each marker (e.g. kilometre post) and the time of passing shall be noted in the report.

The values measured shall, if possible, be recorded at intervals of 50 m. In each case, note should be taken of the time when points **B** and **C** — if possible — as well as when points **D** and **E** are reached and the respective position shall be estimated. The data concerning the engine speed need not be recorded in the report, but should be noted to permit more accurate control of the initial speed.

3. Description of the stopping manoeuvre

The stopping manoeuvre according to figure 1 shall be presented in the form of a diagram. First of all, the time-traverse diagram shall be plotted using the measurements entered in the test report and points **A** to **E** shall be indicated. It will then be possible to determine the average speed between two measurement points and to plot the speed/time diagram.

This is done as follows (see figure 1):

By determining the quotient of the difference of position over the difference in time $\Delta s/\Delta t$, the average speed of the vessel for this period can be calculated.

▼B*Example:*

During the interval between 0 sec. and 10 sec., the distance from 0 m to 50 m is covered.

$$\Delta s / \Delta t = 50 \text{ m} / 10 \text{ s} = 5,0 \text{ m/s} = 18,0 \text{ km/h}$$

This value is entered as the average speed at the 5 sec. abscissa-position. During the second interval, from 10 sec. to 20 sec., a distance of 45 m is covered.

$$\Delta s / \Delta t = 45 \text{ m} / 10 \text{ s} = 4,5 \text{ m/s} = 16,2 \text{ km/h}$$

At marker **D**, the vessel has stopped in relation to the water i.e. current velocity is approximately 5 km/h.

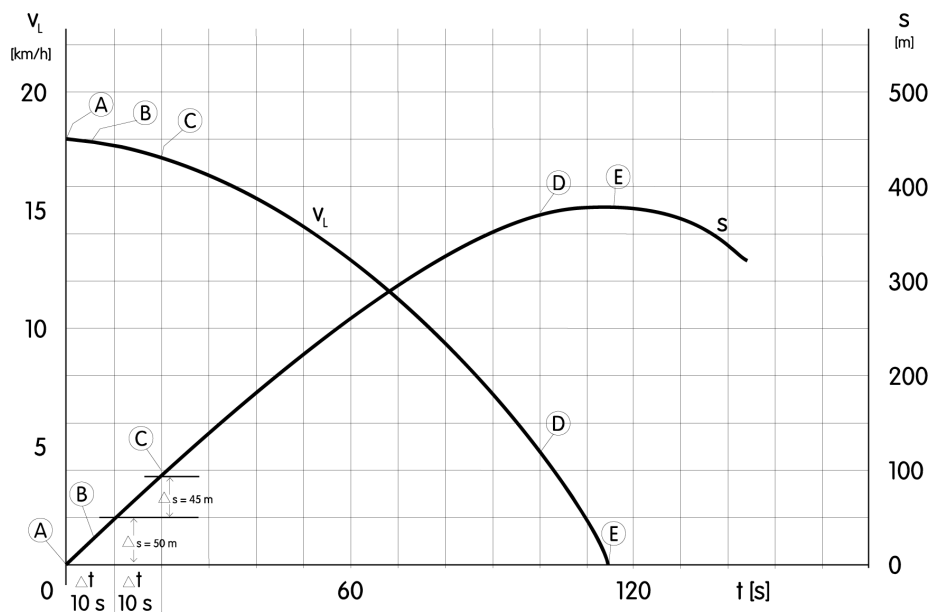
*Figure 1***Stopping manoeuvre**

Key to symbols in figure 1

- A** “stop” order
- B** propeller stopped
- C** propeller in reverse
- D** $v = 0$ in relation to the water
- E** $v = 0$ in relation to the ground
- v speed of vessel
- v_L v in relation to the ground
- s distance covered in relation to the ground
- t measured time

▼B

Table 1

Report of the stopping manoeuvre

Inspection Body: Type of vessel or convoy: Test area:
 L × B [m]: Water level gauge [m]:
 reading
 Date: T at test [m]: Water depth [m]:
 Name: Load at Test [t]: Gradient [m/km]:
 Test run No: % of maximum deadweight V_{STR} [km/h]:
 Power of propulsion engines [m/s]:
 P_B[kW]
 Propulsion system according to Max. displacement [m³]:
 Annex 2, table 2:

Position [river-km]	Time [sec.]	Δs [m]	Δt [sec.]	v _{IL} [km/h]	Engine speed n [min ⁻¹]	Observations



Appendix 2

to Administrative instruction No 2

EVALUATION OF THE RESULTS OF THE STOPPING MANOEUVRE

1. On the basis of the values recorded compliance with the limit values in accordance with Appendix 1 shall be verified. If the conditions for the stopping manoeuvre deviate substantially from the standard conditions, or if there are doubts as to the compliance with the limit values, the results shall be evaluated. To that end the following procedure may be applied for calculating stopping manoeuvres.
2. Theoretical stopping distances are determined under the standard conditions ($S_{\text{reference}}$) of point 2.1 of Administrative instruction No 2 and under stopping manoeuvre conditions (S_{actual}) and are compared with the stopping distance measured (S_{measured}). The corrected stopping distance of the stopping manoeuvre under standard conditions (S_{standard}) is calculated as follows:

Formula 2.1:

$$S_{\text{STANDARD}} = S_{\text{MEASURED}} \cdot \frac{S_{\text{REFERENCE}}}{S_{\text{ACTUAL}}} \leq \text{Limit value in accordance with point 2.1(a) or (b) of Administrative instruction No 2}$$

When the stopping manoeuvre has been carried out with a load of 70-100 % of the maximum deadweight in accordance with point 2.2 of Administrative instruction No 2 in order to calculate S_{standard} the displacement ($D_{\text{reference}} = D_{\text{actual}}$) corresponding to the load at the time of the test shall be used for the determination of $S_{\text{reference}}$ and S_{actual} .

When in determining S_{standard} according to formula 2.1, the limit value in question is exceeded or not reached, the value of $S_{\text{reference}}$ shall be reduced or increased by variation of $D_{\text{reference}}$ so that the limit value is complied with ($S_{\text{standard}} = \text{limit value in question}$). The maximum displacement permitted in downstream navigation shall be set accordingly.

3. According to the limit values given in point 2.1(a) and (b) of Administrative instruction No 2, only the stopping distances measured in
 - Phase I (“Full ahead” reversed to “full astern”): S_I
 - and
 - Phase II (End of reversal until vessel stops in relation to the water): S_{II}
 shall be calculated (see figure 1). The total stopping distance is then:

Formula 3.1:

$$S_{\text{total}} = S_I + S_{II}$$

4. The particular stopping distances shall be calculated as follows:

▼ B

CALCULATION OF THE STOPPING MANOEUVRE

Figure 2

Diagram

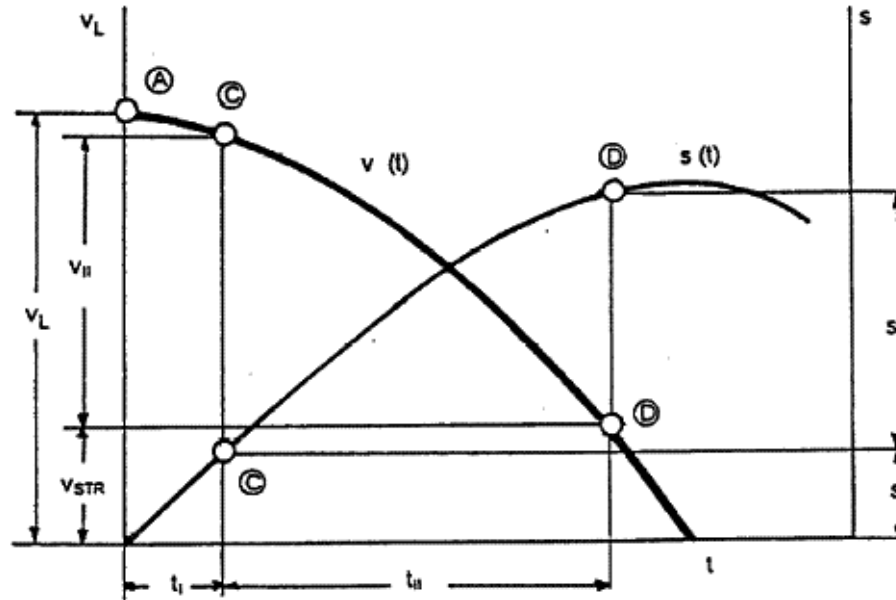

Calculation Formulae:

$$4.1. \quad S_I = k_1 \cdot v_L \cdot t_1$$

$$t_1 \leq 20 \text{ s}$$

with the following coefficients

— k_1 according to table 1

$$4.2. \quad S_{II} = k_2 \cdot v_{II}^2 \cdot \frac{D \cdot g}{k_3 \cdot F_{POR} + R_{TmII} - R_G} \cdot \left(k_4 + \frac{v_{STR}}{v_{II}} \right)$$

— k_2, k_3, k_4 according to table 1

$$4.3. \quad R_{TmII} = (R_T/v^2) \cdot (k_7 \cdot k_6 \cdot (v_L - v_{STR}))^2$$

— k_6, k_7 according to table 1

— R_T/v^2 according to table 3

$$4.4. \quad R_G = i \cdot D \cdot \rho \cdot g \cdot 10^{-6}$$

$$4.5. \quad v_{II} = k_6 \cdot (v_L - v_{STR})$$

— k_6 according to table 1

$$4.6. \quad F_{POR} = f \cdot P_B$$

— f according to table 2

$$4.7. \quad t_{II} = \frac{S_{II}}{v_{II} \cdot \left(k_4 + \frac{v_{STR}}{v_{II}} \right)}$$

— k_4 according to table 1

In formulae 4.1 to 4.7:

v_L	Speed in relation to the ground at the start of reversal	(m/s)
t_I	Reversal time	(s)
v_{II}	Speed in relation to the water at the end of reversal	(m/s)
D	Displacement	(m ³)
F_{POR}	Bollard pull in reverse	(kN)
P_B	Power of propulsion engine	(kW)
R_{TmII}	Average resistance during phase II, to be determined using the diagram for determining R_T/v^2	(kN)

▼ B

R_G	Gradient resistance	(kN)
i	Gradient in m/km (if missing to be taken as 0,16)	(m/km)
v_{STR}	Average current velocity	(m/s)
g	Acceleration due to gravity (9,81)	(m/s ²)
ρ	Density of water, ρ fresh water = 1 000	(kg/m ³)
T	Maximum draught (of vessel or convoy)	(m)
h	Water depth	(m)
B	Width	(m)
L	Length	(m)

The coefficients for the formulae 4.1, 4.2, 4.3, 4.4, 4.5, 4.6 and 4.7 can be taken from the tables below.

Table 1

k factors for:

- (a) Motor vessels and single file convoys
- (b) Two-abreast convoys
- (c) Three-abreast convoys

	a	b	c	Units
k_1	0,95	0,95	0,95	—
k_2	0,115	0,120	0,125	$\frac{kg \cdot s^2}{m^4}$
k_3	1,20	1,15	1,10	—
k_4	0,48	0,48	0,48	—
k_6	0,90	0,85	0,80	—
k_7	0,58	0,55	0,52	—

Table 2

Coefficient f for ratio between bollard pull in reverse and the power of the propulsion engines

Propulsion system	f	Units
Modern nozzles with rounded rear edge	0,118	kN/kW
Old nozzles with sharp rear edge	0,112	kN/kW
Propellers without nozzle	0,096	kN/kW
Rudder propellers with nozzles (generally sharp rear edge)	0,157	kN/kW
Rudder propellers without nozzles	0,113	kN/kW

▼ B

Table 3

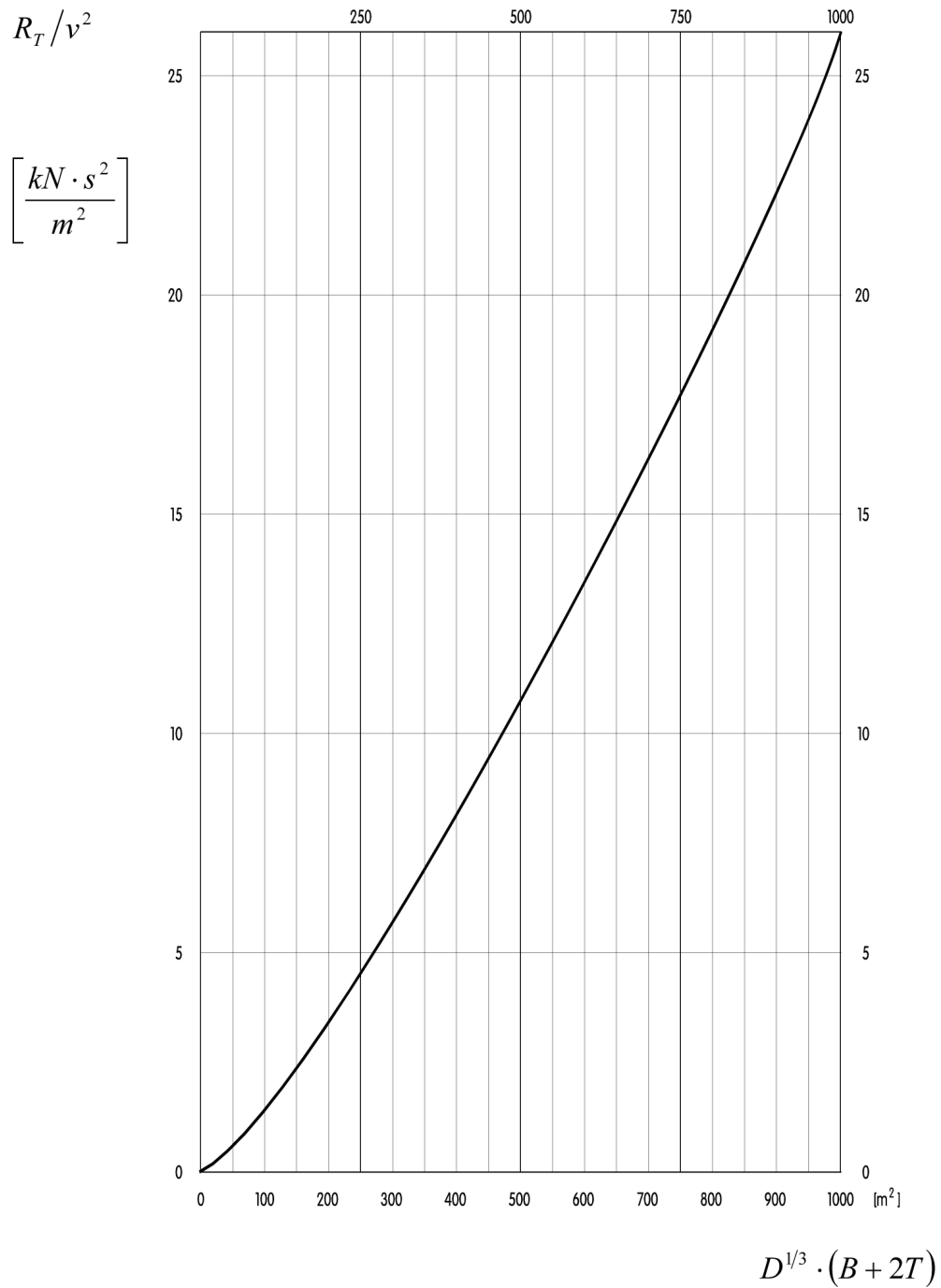
Diagram concerning the calculation of resistanceTo determine the value of R_T/v^2 in relation to $D^{1/3} [B + 2T]$:



Annex to Appendix 2

to Administrative instruction No 2

Examples on the application of Appendix 2
(Evaluation of the results of the stopping manoeuvre)

EXAMPLE I

1. Data of vessels and convoy

Formation: ordinary motor vessel with a (Europa IIa) lighter coupled abreast

	L [m]	B [m]	T _{max} [m]	Dwt (*) _{max} [t]	D _{max} [m ³]	P _B [kW]
Motor vessel	110	11,4	3,5	2 900	3 731	1 500
Lighter	76,5	11,4	3,7	2 600	2 743	—
Convoy	110	22,8	3,7	5 500	6 474	1 500

Propulsion system of the motor vessel: modern nozzles with rounded rear edge

(*) Dwt = deadweight.

2. Values measured during the stopping manoeuvre

Current velocity:	$v_{STR_{actual}}$	=	1,4 m/s	≈	5,1 km/h
Speed of vessel (in relation to the water):	$V_{S_{actual}}$	=	3,5 m/s	≈	12,5 km/h
Speed of vessel (in relation to the ground):	$V_{L_{actual}}$	=	4,9 m/s	≈	17,6 km/h
Reversal time (measured) (point A to C):	t_I	=	16 s		
Stopping distance in relation to the water (point A to D):	$S_{MEASURED}$	=	340 m		
Load condition (possibly estimated):	D_{actual}	=	5 179 m ³	≈	0,8 D _{max}
Actual draught of convoy:	T_{actual}	=	2,96 m	≈	0,8 T _{max}

3. Limit value according to point 2.1(a) or (b) to be compared with $S_{standard}$

Since $B > 11,45$ m and since the convoy is in flowing water, the following is applicable for this convoy under 2.1(a):

$$S_{standard} < 550 \text{ m}$$

4. Determination of corrected stopping distance compared to standard conditions

— Measured value according to Appendix 1 (see point 2)

$$s_{measured} = 340 \text{ m}$$

— to be calculated:

s_{actual} as the sum of

$$s_{I_{actual}} \quad (\text{according to formula 4.1 of Appendix 2 with } v_{L_{actual}})$$

and

$$s_{II_{actual}} \quad (\text{according to formulae 4.2, 4.3, 4.4, 4.5 and 4.6 of Appendix 2 with actual speeds } v_{II_{actual}}, v_{STR_{actual}}, D_{actual})$$

$s_{reference}$ as the sum of

$$s_{I_{reference}} \quad (\text{according to formula 4.1 of Appendix 2 with } v_{L_{reference}})$$

and

▼ **B**

$s_{II_{reference}}$ (according to formulae 4.2 to 4.6 of Appendix 2 with the reference speeds according to 2.1 of the Administrative instruction and given that the load condition is greater than 70 % of the maximum load (≈ 80 %):
 $D_{reference} = D_{actual}$ and $T_{reference} = T_{actual}$)

— to be checked:

$$S_{standard} = S_{measured} \cdot \frac{S_{reference}}{S_{actual}} \leq 550 \text{ m}$$

4.1. Coefficients for the calculation taken from Appendix 2

Table 1

for $s_{I_{actual}}$ and $s_{I_{reference}}$	$k_1 = 0,95$
for $s_{II_{actual}}$ and $s_{II_{reference}}$	$k_2 = 0,12$
	$k_3 = 1,15$
	$k_4 = 0,48$
	$k_6 = 0,85$
	$k_7 = 0,55$

Table 2 (for modern nozzles with rounded rear edge)

$$f = 0,118$$

4.2. Calculation of S_{actual}

(a) $s_{I_{actual}}$ with the values measured during the stopping manoeuvre (formula 4.1)

$$S_{I_{actual}} = k_1 \cdot v_{L_{actual}} \cdot t_{I_{actual}}$$

$$S_{I_{actual}} = 0,95 \cdot 4,9 \cdot 16 = 74,5 \text{ m}$$

(b) Formula for $s_{II_{actual}}$

$$S_{II_{actual}} = k \cdot v_{II_{actual}}^2 \cdot \frac{D_{actual} \cdot g}{k_3 \cdot F_{POR} + R_{TmII_{actual}} - R_G} \cdot \left(k_4 + \frac{V_{STR_{actual}}}{V_{II_{actual}}} \right)$$

(c) Calculation of $R_{TmII_{actual}}$ according to table 3 and formula 4.3 of Appendix 2

$$D_{actual}^{1/3} = 5\,179^{1/3} + 17,3[m]$$

$$D_{actual}^{1/3} \cdot (B + 2 \cdot T_{actual}) = 17,3 \cdot (22,8 + 5,92) = 496,8 [m^2]$$

$$\text{according to table 3 } \frac{R_T}{v^2} = 10,8 \left[\frac{kN \cdot s^2}{m^2} \right]$$

$$v_{L_{actual}} - v_{STR_{actual}} = 4,9 - 1,4 = 3,5 \text{ m/s}$$

$$R_{TmII_{actual}} = \frac{R_T}{v_2} \cdot \left(k_7 \cdot k_6 \cdot (v_{L_{actual}} - v_{STR_{actual}}) \right)^2 = 10,8 \cdot (0,55 \cdot 0,85 \cdot 3,5)^2 = \underline{28,8[kN]}$$

(d) Calculation of resistance to gradient R_G according to formula 4.4

$$R_G = 10^{-6} \cdot (0,16 \cdot D_{actual} \cdot \rho \cdot g) = 10^{-6} \cdot (0,16 \cdot 5\,179 \cdot 1\,000 \cdot 9,81) = \underline{8,13[kN]}$$

(e) Calculation of $v_{II_{actual}}$ according to formula 4.5

$$v_{II_{actual}} = k_6 \cdot (v_{L_{actual}} - v_{STR_{actual}}) = 0,85 \cdot 3,5 = 2,97 [m/s]$$

$$v_{II_{actual}}^2 = 8,85 [m/s]^2$$

▼ B

(f) Calculation of F_{POR} according to formula 4.6 and table 2

$$F_{POR} = 0,118 \cdot 1\,500 = \underline{177[kN]}$$

(g) Calculation of $s_{II_{actual}}$ using formula (b) and the results of (c), (d), (e) and (f)

$$s_{II_{actual}} = \frac{0,12 \cdot 8,85 \cdot 9,81 \cdot \left(0,48 + \frac{1,4}{2,97}\right)}{1,15 \cdot 177 + 28,8 - 8,13} \cdot 5\,179$$

$$s_{II_{actual}} = \underline{228,9\,m}$$

(h) Calculation of total distance according to formula 3.1

$$s_{actual} = 74,51 + 228,9 = \underline{303,4\,m}$$

Note: The term $(R_{mII} - R_G)$, which is a function of D , with an actual value of 20,67 kN is obviously relatively small compared to $k_3 \cdot F_{POR}$ with an actual value of 203,55 kN, so for simplification purposes, s_{II} can be taken as proportional to D , i.e. $s_{II} = \text{Constant} \cdot D$.

4.3. Calculation of $s_{reference}$

Initial values

$$v_{STR_{reference}} = 1,5\,m/s = 5,4\,km/h \quad D_{reference} = D_{actual} = 5\,179\,m^3$$

$$v_{S_{reference}} = 3,6\,m/s = 13\,km/h \quad T_{reference} = T_{actual} = 2,96\,m$$

$$v_{L_{reference}} = 5,1\,m/s = 18,4\,km/h$$

$$(a) S_{I_{reference}} = k_1 \cdot v_{L_{reference}} \cdot t_I$$

$$S_{I_{reference}} = 0,95 \cdot 5,1 \cdot 16 = \underline{77,50\,m}$$

$$(b) S_{II_{reference}} = k_2 \cdot v_{II_{reference}}^2 \cdot \frac{D_{reference} \cdot g}{k_3 \cdot F_{POR} + R_{TmII_{reference}} - R_G} \cdot \left(k_4 + \frac{v_{STR_{reference}}}{v_{II_{reference}}}\right)$$

(c) calculation of $R_{TmII_{reference}}$

$$\frac{R_T}{v^2} = 10,8 \left[\frac{kN \cdot s^2}{m^2} \right] \text{ as in point 4.2, since } B, D \text{ and } T \text{ are unchanged.}$$

$$v_{L_{reference}} - v_{STR_{reference}} = 3,6\, [m/s]$$

$$R_{TmII_{reference}} = \frac{R_T}{v^2} \cdot \left(k_7 \cdot k_6 \cdot \left(v_{L_{reference}} - v_{STR_{reference}}\right)\right)^2 = 10,8 \cdot (0,55 \cdot 0,85 \cdot 3,6)^2 = \underline{30,99[kN]}$$

(d) Resistance due to gradient R_G as in point 4.2

(e) Calculation of $v_{II_{reference}}$

$$v_{II_{reference}} = k_6 \cdot \left(v_{L_{reference}} - v_{STR_{reference}}\right) = 0,85 \cdot 3,6 = 3,06\, [m/s], \quad v_{II_{reference}}^2 = 9,36\, [m/s]^2$$

(f) F_{POR} as in point 4.2.

▼ B

(g) Calculation of $s_{II_{reference}}$ using formula (b) and the result from (c) to (f)

$$s_{II_{reference}} = \frac{0,12 \cdot 9,36 \cdot 9,81 \cdot \left(0,48 + \frac{1,5}{3,06}\right)}{1,15 \cdot 177 + 30,99 - 8,13} \cdot 5\,179$$

$$= \underbrace{0,0472} \cdot 5\,179 = \underline{244,5\,m}$$

Constant_{reference}

(h) Calculation of total distance

$$s_{reference} = s_{I_{reference}} + s_{II_{reference}} = 77,5 + 244,5 = \underline{322\,m}$$

4.4. Verification of compliance with permissible stopping distance under standard conditions $s_{standard}$

according to formula 2.1 of Appendix 2

$$s_{standard} = s_{measured} \cdot \frac{s_{reference}}{s_{actual}} = 340 \cdot \frac{322}{303,4} = \underline{360,8\,m < 550\,m}$$

Conclusion:

The permissible limit value is far from being reached, i.e.:

- admission to downstream navigation is possible without problems for the actual load condition ($0,8 \cdot D_{max}$),
- a higher load condition is possible and may be calculated according to point 5 below.

5. **Possible increase of D_{actual}** in downstream navigation

$$(s_{standard})_{Limit} = s_{measured} \cdot \frac{(s_{reference})_{Limit}}{s_{actual}} = 550\,m$$

$$(s_{reference})_{Limit} = 550 \cdot \frac{s_{actual}}{s_{measured}} = 550 \cdot \frac{303,4}{340} = 490,8\,m$$

With $s_{II_{reference}} = \text{Constant}_{reference} \cdot D$ according to the note under point 4.2

$$(s_{reference})_{Limit} = (s_{I_{reference}} + s_{II_{reference}})_{Limit} = s_{I_{reference}} + 0,0472 \cdot (D_{reference})_{Limit}$$

Hence

$$(D_{reference})_{Limit} = \frac{(s_{reference})_{Limit} - s_{I_{reference}}}{0,0472} = \frac{490,8 - 77,5}{0,0472} = \underline{8\,756\,m^3}$$

From this follows that:

Since $(D_{reference})_{Limit} > D_{max}$ ($8\,756 > 6\,474$) this formation (see point 1) may be permitted in downstream navigation with full load.

EXAMPLE II

1. **Data of vessels and convoy**

Formation: large motor vessel propelling

2 lighters side-by-side in front and

1 lighter coupled side-by-side

	L [m]	B [m]	T _{max} [m]	Dwt (*) _{max} [t]	D _{max} [m ³]	P _B [kW]
Motor vessel	110	11,4	3,5	2 900	3 731	1 500
Each lighter	76,5	11,4	3,7	2 600	2 743	—

▼ B

	L [m]	B [m]	T _{max} [m]	Dwt (*) _{max} [t]	D _{max} [m ³]	P _B [kW]
Convoy	186,5	22,8	3,7	10 700	11 960	1 500

Propulsion system of the self-propelled vessel: modern nozzles with rounded rear edge.

(*) Dwt = deadweight.

2. Values measured during the stopping manoeuvre

Current velocity:	$v_{STR_{actual}}$	=	1,4 m/s	≈	5,1 km/h
Speed of vessel (in relation to the water):	$V_{S_{actual}}$	=	3,5 m/s	≈	12,5 km/h
Speed of vessel (in relation to the bank):	$V_{L_{actual}}$	=	4,9 m/s	≈	17,6 km/h
Reversal time (measured) (point A to C):	t_I	=	16 sec		
Stopping distance in relation to the water (point A to D):	$s_{measured}$	=	580 m		
Load condition (possibly estimated):	D_{actual}	=	9 568 m ³	≈	0,8 D _{max}
Actual draught of convoy:	T_{actual}	=	2,96 m	≈	0,8 T _{max}

3. Limit value according to paragraph 2.1(a) or (b) of the Administrative instruction to be compared with $s_{standard}$

Since $B > 11,45$ and the convoy is in flowing water, the following applies for this convoy under point 2.1(a):

$$s_{standard} \leq 550 \text{ m}$$

4. Determination of the corrected stopping distance compared with standard conditions

— Measured value:

$$s_{measured} = 340 \text{ m}$$

— calculations to be made:

s_{actual} as the sum of

$$s_{I_{actual}} \quad (\text{according to formula 4.1 of Appendix 2 with } V_{L_{actual}})$$

and

$$s_{II_{actual}} \quad (\text{according to formulae 4.2, 4.3, 4.4, 4.5 and 4.6 of Appendix 2 with real speeds } v_{L_{actual}} \text{ (see under 2 above) and } D_{actual})$$

$$s_{reference}: \text{ sum } s_{I_{reference}} + s_{II_{reference}} \quad (\text{according to formulae 4.1 to 4.6 of Appendix 2 with reference speeds and in conformity of Appendix 2, because the load condition } > 70 \% \text{ of maximum, where } D_{reference} = D_{actual} \text{ and } T_{reference} = T_{actual})$$

— to be verified:

$$s_{standard} = s_{measured} \cdot \frac{s_{reference}}{s_{actual}} \leq 550 \text{ m, otherwise}$$

— calculate:

$$s^*_{standard} = 550 \text{ m by reduction of } D_{actual} \text{ to } D^*$$

4.1. Coefficients for the calculation according to Appendix 2

Table 1

for $s_{I_{actual}}$ and $s_{I_{reference}}$	k_1	=	0,95
for $s_{II_{actual}}$ and $s_{II_{reference}}$	k_2	=	0,12
	k_3	=	1,15

▼ **B**

$$\begin{aligned} k_4 &= 0,48 \\ k_5 &= 0,85 \\ k_7 &= 0,55 \end{aligned}$$

Table 2 (for modern nozzles with rounded rear edge)

$$f = 0,118$$

4.2. Calculation of $s_{I_{actual}}$

(a) $s_{I_{actual}}$ Using the values measured during the stopping manoeuvres

$$\begin{aligned} s_{I_{actual}} &= k_1 \cdot v_{L_{actual}} \cdot t_{I_{actual}} \\ s_{I_{actual}} &= 0,95 \cdot 4,8 \cdot 16 = \underline{73 \text{ m}} \end{aligned}$$

(b) formula for $s_{II_{actual}}$

$$s_{II_{actual}} = k_2 \cdot v_{II_{actual}}^2 \cdot \frac{D_{actual} \cdot g}{k_3 \cdot F_{POR} + R_{T_{II_{actual}}} - R_G} \cdot \left(k_4 + \frac{v_{STR_{actual}}}{v_{II_{actual}}} \right)$$

(c) Calculation of $R_{T_{II_{actual}}}$ according to table 3 and formula 4.3 of Appendix 2

$$D_{actual}^{1/3} = 9\,568^{1/3} = 21,2 \text{ [m]}$$

$$D_{actual}^{1/3} \cdot (B + 2 \cdot T_{actual}) = 21,2 \cdot (22,8 - 5,92) = 609 \text{ [m}^2\text{]}$$

$$\text{from table 3 } \frac{R_T}{v^2} = 14,0 \left[\frac{\text{kN} \cdot \text{s}^2}{\text{m}^2} \right]$$

$$v_{L_{actual}} - v_{STR_{actual}} = 4,8 - 1,4 = 3,4 \text{ m/s}$$

$$R_{T_{II_{actual}}} = \frac{R_T}{v^2} \cdot \left(k_7 \cdot k_6 \cdot (v_{L_{actual}} - v_{STR_{actual}}) \right)^2 = 14,0 \cdot (0,55 \cdot 0,85 \cdot 3,4)^2 = \underline{35,4 \text{ [kN]}}$$

(d) Calculation of resistance due to gradient R_G according to formula 4.4 of Appendix 2.

$$R_G = 10^{-6} \cdot (0,16 \cdot D_{actual} \cdot \rho \cdot g) = 10^{-6} \cdot (0,16 \cdot 9\,568 \cdot 1\,000 \cdot 9,81) = \underline{15,02 \text{ [kN]}}$$

(e) Calculation of $v_{II_{actual}}$ according to formula 4.5 of Appendix 2

$$v_{II_{actual}} = k_6 \cdot (v_{L_{actual}} \cdot v_{STR_{actual}}) = \underline{2,89 \text{ [m/s]}}$$

$$v_{II_{actual}}^2 = \underline{8,35 \text{ [m/s]}^2}$$

(f) Calculation of F_{POR} according to formula 4.6 and table 2

$$F_{POR} = 0,118 \cdot 1\,500 = \underline{177 \text{ [kN]}}$$

(g) Calculation of $s_{II_{actual}}$ using formula (b) and the result of (c), (d), (e) and (f)

$$s_{II_{actual}} = \frac{0,12 \cdot 8,35 \cdot 9,81 \cdot \left(0,48 + \frac{1,4}{2,89} \right)}{1,15 \cdot 177 + 35,4 - 15,02} \cdot 9\,568$$

$$s_{II_{actual}} = \underline{402 \text{ m}}$$

(h) Calculation of the total distance according to formula 3.1

$$s_{actual} = 73 + 402 = \underline{475 \text{ m}}$$

▼ **B**4.3. Calculation of $s_{reference}$

Initial values:

$$V_{STR_{reference}} = 1,5 \text{ m/s} \approx 5,4 \text{ km/h} \quad D_{reference} = D_{actual} = 9\,568 \text{ m}^3$$

$$V_{S_{reference}} = 3,6 \text{ m/s} \approx 13 \text{ km/h} \quad T_{reference} = T_{actual} = 2,96 \text{ m}$$

$$V_{L_{reference}} = 5,1 \text{ m/s} \approx 18,4 \text{ km/h}$$

$$(a) S_{I_{reference}} = k_1 \cdot v_{L_{reference}} \cdot t_1$$

$$S_{I_{reference}} = 0,95 \cdot 5,1 \cdot 16 = \underline{77,50 \text{ m}}$$

$$(b) S_{II_{reference}} = k_2 \cdot v_{II_{reference}}^2 \cdot \frac{D_{reference} \cdot g}{k_3 \cdot F_{POR} + R_{TmII_{reference}} - R_G} \cdot \left(k_4 + \frac{v_{STR_{reference}}}{v_{II_{reference}}} \right)$$

(c) Calculation of $R_{TmII_{reference}}$

$$\frac{R_T}{v^2} = 14,0 \left[\frac{\text{kN} \cdot \text{s}^2}{\text{m}^2} \right] \text{ as under point 4.2 since B, D and T are unchanged}$$

$$v_{L_{reference}} - v_{STR_{reference}} = 3,6 \text{ [m/s]}$$

$$R_{TmII_{reference}} = 14,0 \cdot (0,55 \cdot 0,85 \cdot 3,6)^2 = \underline{39,6 \text{ [kN]}}$$

(d) Resistance due to gradient R_G as under point 4.2(e) Calculation of $v_{II_{reference}}$

$$v_{II_{reference}} = 0,85 \cdot 3,6 = \underline{3,06 \text{ [m/s]}}, \quad v_{II_{reference}}^2 = 9,36 \text{ [m/s]}^2$$

(f) F_{POR} as under point 4.2(g) Calculation of $S_{II_{reference}}$ using formula (b) and the result of (c) to (f)

$$S_{II_{reference}} = \frac{0,12 \cdot 9,36 \cdot 9,81 \cdot \left(0,48 + \frac{1,5}{3,06} \right)}{1,15 \cdot 177 + 39,6 - 15,02} \cdot 9\,568$$

$$S_{II_{reference}} = \underbrace{0,04684}_{\text{Constant}_{reference}} \cdot 9\,568 = \underline{448 \text{ m}}$$

(h) Calculation of the total distance

$$S_{reference} = S_{I_{reference}} + S_{II_{reference}} = 77,5 + 448 = \underline{525,5 \text{ m}}$$

4.4. Verification of compliance with permissible stopping distance under standard conditions $S_{standard}$

according to formula 2.1 of Appendix 2

$$S_{standard} = S_{measured} \cdot \frac{S_{reference}}{S_{actual}} = 580 \cdot \frac{525,5}{475} = \underline{641 \text{ m} > 550 \text{ m}}$$

Conclusion: The limit value has clearly been exceeded; admission to downstream navigation is possible only with a load restriction. This restricted load can be determined in conformity with No 5 below.

▼ B5. **D* permissible in downstream navigation according to formula 2.1 of Appendix 2**

$$S_{standard} = S_{measured} \cdot \frac{S_{reference}^*}{S_{actual}} = 550 \text{ m}$$

Therefore:

$$S_{reference}^* = 550 \cdot \frac{S_{actual}}{S_{measured}} = S_{I_{reference}} + S_{II_{reference}}^*$$

$$S_{II_{reference}}^* = \text{Constant}_{reference} \cdot D^* = 0,04684 \cdot D^*$$

$$D^* = \frac{550 \cdot \frac{475}{580} - 77,5}{0,04684} = 7\,950 [\text{m}^3]$$

Consequence: Since in downstream navigation the permissible displacement D^* is only $7\,950 \text{ m}^3$, the permissible deadweight (perm. Dwt.) in this formation is approximately:

$$\frac{\text{perm.Dwt.}}{\text{max.Dwt.}} = \frac{D^*}{D_{\text{max}}} = \frac{7\,950}{11\,960} = 0,66$$

Permissible deadweight (see point 1)

$$0,66 \cdot 10\,700 = 7\,112 \text{ t}$$



ADMINISTRATIVE INSTRUCTION No 3

Requirements for coupling systems and coupling devices for craft suitable for propelling or being propelled in a rigid assembly

(Articles 16.01, 16.02, 16.06, 16.07 of Annex II)

In addition to the requirements of Chapter 16 of Annex II, the relevant provisions of the navigational authority regulations in force in the Member States shall be observed.

1. General requirements

- 1.1. Every coupling system shall guarantee the rigid coupling of all the craft in a convoy, i.e. under foreseen operating conditions the coupling device shall prevent longitudinal or transversal movement between the vessels, so that the assembly can be seen as a “nautical unit”.
- 1.2. The coupling system and its components shall be safe and easy to use, enabling craft to be coupled rapidly without endangering personnel.
- 1.3. The forces arising from foreseen operating conditions shall be properly absorbed and safely transmitted into the vessel’s structure by the coupling system and its components.
- 1.4. A sufficient number of coupling points shall be available.

2. Coupling forces and dimensioning of coupling devices

The coupling devices of convoys and formations of vessels to be authorised shall be dimensioned so as to guarantee sufficient safety levels. This condition is deemed to be fulfilled if the coupling forces determined according to points 2.1, 2.2 and 2.3 are assumed to be the tensile strength for the dimensioning of the longitudinal coupling components.

- 2.1. Coupling points between pusher and pushed lighters or other craft:

$$F_{SB} = 270 \cdot P_B \cdot \frac{L_S}{B_s} \cdot 10^{-3} [kN]$$

- 2.2. Coupling points between pushing motor vessel and pushed craft:

$$F_{SF} = 80 \cdot P_B \cdot \frac{L_S}{h_K} \cdot 10^{-3} [kN]$$

- 2.3. Coupling points between pushed craft:

$$F_{SL} = 80 \cdot P_B \cdot \frac{L'_S}{h'_K} \cdot 10^{-3} [kN]$$

A value of 1200 kN is deemed to be sufficient for the maximum coupling force for a pushing craft at the coupling point between the first pushed craft and the craft coupled ahead of it, even if formula in point 2.3 produces a higher value.

For the coupling points of all other longitudinal connections between pushed craft, the dimensioning of the coupling devices shall be based on the coupling force determined according to formula in point 2.3.

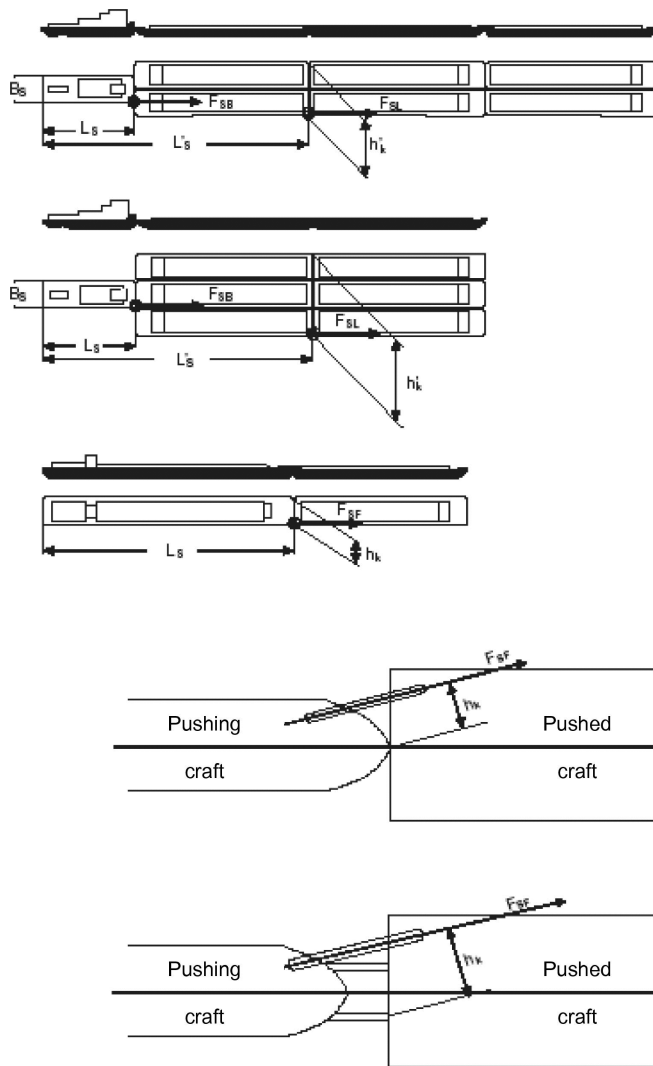
▼ B

Where:

F_{SB} , F_{SF} , F_{SL} [kN]	Coupling force of the longitudinal connection;
P_B [kW]	Installed power of the propulsion engine;
L_S [m]	Distance from the stern of the pusher or pushing craft to the coupling point;
L'_S [m]	Distance from the stern of the pushing craft to the coupling point between the first pushed craft and the craft coupled ahead of it;
h_k , h'_k [m]	Respective lever arm of the longitudinal connection;
B_S [m]	Width of the pushing craft;
270 and 80 $\left[\frac{\text{kN}}{\text{kW}} \right]$	Empirically established values for the conversion of installed power to thrust while ensuring adequate levels of safety.

- 2.4.1. For the longitudinal coupling of individual craft at least two coupling points shall be used. Each coupling point shall be dimensioned for the coupling force determined according to points 2.1, 2.2 or 2.3. If rigid coupling components are used, a single coupling point may be authorised if that point ensures secure connection of the craft.

The tensile strength of the cables shall be selected according to the foreseen number of windings. There shall be no more than three windings at the coupling point. Cables shall be selected according to their intended use.

▼B

- 2.4.2. In the case of pushers with a single pushed lighter, formula in point 2.2 can be used to determine the coupling force if such pushers have been authorised to propel several such lighters.
- 2.4.3. Sufficient numbers of bollards or equivalent devices shall be available and be capable of absorbing the coupling forces arising.

3. **Special requirements for articulated couplings**

Articulated couplings shall be designed so as to also ensure a rigid coupling between craft. Compliance with the requirements of Chapter 5 shall be checked during navigation tests with a rigid convoy in accordance with Article 16.06.

The drive unit of the articulated coupling shall enable a satisfactory return from the articulated position. The requirements of Articles 6.02 to 6.04 shall be applied *mutatis mutandis*, hence when a powered drive unit is used, a second independent drive unit and energy source shall be available in the event of failure.

It shall be possible to operate and monitor the articulated coupling (its articulated movement, at least) from the wheelhouse, the requirements of Articles 7.03 and 7.05 shall be applied *mutatis mutandis*.

▼B

ADMINISTRATIVE INSTRUCTION No 4

(Left void)



ADMINISTRATIVE INSTRUCTION No 5

Noise measurements

(Article 3.04(7), Article 7.01(2), Article 7.03(6), Article 7.09(3), Article 8.10, Article 11.09(3), Article 12.02(5), Article 17.02(3)(b), and Article 17.03(1) of Annex II)

1. General

In order to check the maximum sound pressure levels given in Annex II, measured values, measurement procedures and conditions for the quantitative, reproducible recording of sound pressure levels in accordance with points 2 and 3 shall be established.

2. Measuring instruments

The measuring instrument shall meet the requirements of class 1 according to EN 60651:1994.

Before and after each set of measurements, a class 1 calibrator according to EN 60942:1998 shall be placed on the microphone in order to calibrate the measurement system. The compliance of the calibrator with the requirements of EN 60942:1998 shall be checked once per year. The compliance of the measuring equipment with the requirements of EN 60651:1994 shall be checked every two years.

3. Noise measurements**3.1. On board craft**

Measurements shall be carried out in accordance with ISO 2923:2003 Sections 5 to 8 measuring only A-weighted sound pressure levels.

3.2. Air noise emitted from craft

Noise emissions from craft on inland waterways and in ports are determined by means of measurements in accordance with EN ISO 22922:2000, Sections 7 to 11. Doors and windows of engine rooms shall be closed during measurements

4. Documentation

Measurements shall be recorded according to the “Noise Measurement Report” (Annex).

Noise Measurement Report

— on board craft in accordance with ISO 2923:2003

— air noise emitted from craft in accordance with EN ISO 2922:2000 (*)

A. Craft data**1. Craft type and name:**

Unique European vessel identification number:

2. Owner:**3. Main propulsion system:****3.1. Main engines:**

Number	Manufacturer	Type	Year of construction	Power (kW)	Engine speed (min ⁻¹)	Two-stroke/four-stroke	Turbo-charged yes/no
1							
2							

(*) Delete as appropriate.

▼ B

3.2. Transmission

Manufacturer: Type: Gear reduction: 1:

3.3. Propellers

Number: Number of blades: Diameter: mm Nozzle: yes/no (*)

3.4. Steering system

Type:

4. Auxiliaries:

Number	Propulsion of	Manufacturer	Type	Year of construction	Power (kW)	Engine speed (min ⁻¹)
1						
2						
3						
4						
5						

5. Noise reduction measures implemented:

6. Observations:

B. Measuring instruments used

1. Sound pressure level meter:

Manufacturer: Type: Latest check:

2. Octave/Third octave band analyser:

Manufacturer: Type: Latest check:

3. Calibrator:

Manufacturer: Type: Latest check:

4. Accessories:

5. Observations:

C. Measurement conditions — craft

1. Formation during the measurements:

2. Load/displacement: t/m³ (*) (approximately % of maximum value)

3. Speed of main engine: min⁻¹ (approximately % of maximum value)

4. Auxiliaries in service No:

5. Observations:

D. Measurement conditions — surroundings

1. Area of measurement: Upstream/downstream (*)

2. Water depth: m (Relevant water level = m)

3. Weather: Temperature: °C; Wind strength: BF

4. External noise interference: yes/no (*), if yes, specify:

5. Observations:

(*) Delete as appropriate.

▼B**E. Recording of measurement**

1. Measurement carried out by:
2. Date:
3. Observations:
4. Signature:

F.1. Measurement results

Noise measurements on board craft:

Number	Measurement point	Doors		Windows		Measured value in dB(A)	Observations
		open	closed	open	closed		

F.2. Measurement results

Measurement of air noise emitted from craft:

Number	Measurement point	Measured values in dB(A)	Observations

▼B

ADMINISTRATIVE INSTRUCTION No 6

(Left void)



ADMINISTRATIVE INSTRUCTION No 7

Special anchors with reduced mass

(Article 10.01(5) of Annex II)

*PART 1**Authorised special anchors*

Special anchors with reduced mass authorised by the competent authorities in accordance with Article 10.01(5) are presented in the following table.

Anchor No	Authorised reduction of anchor mass (%)	Competent authority
1. HA-DU	30 %	Germany
2. D'Hone Spezial	30 %	Germany
3. Pool 1 (hollow)	35 %	Germany
4. Pool 2 (solid)	40 %	Germany
5. De Biesbosch-Danforth	50 %	Germany
6. Vicinay-Danforth	50 %	France
7. Vicinay AC 14	25 %	France
8. Vicinay Type 1	45 %	France
9. Vicinay Type 2	45 %	France
10. Vicinay Type 3	40 %	France
11. Stockes	35 %	France
12. D'Hone-Danforth	50 %	Germany
13. Schmitt high holding anchor	40 %	Netherlands

*PART 2**Authorisation and test procedure of special anchors with reduced mass*

(Reduction of the anchor mass values determined in accordance with Article 10.01(1) to (4) of Annex II)

1. Chapter 1 — Authorisation procedure

- 1.1. Special anchors with reduced mass in accordance with Article 10.01(5) of Annex II shall be authorised by the competent authorities. The competent authority determines the authorised reduction of anchor mass for special anchors in accordance with the procedure outlined below.
- 1.2. Authorisation as special anchor is only possible if the reduction of anchor mass established is at least 15 %.
- 1.3. Applications for the authorisation of a special anchor in accordance with point 1.1 shall be submitted to the competent authority of a Member State. Ten copies of the following documents shall be forwarded with each application:
 - (a) an outline of the dimensions and mass of the special anchor, giving the main dimensions and type designation for each available anchor size;

▼ B

(b) a braking force diagram for the reference anchor A (in accordance with point 2.2) and the special anchor B to be authorised which has been prepared and assessed by an institution designated by the competent authority.

- 1.4. The competent authority notifies the Commission of any applications to reduce anchor mass which it considers to authorise after testing. The competent authority consequently notifies the Commission of any authorised special anchor, giving its type designation and authorised reduction of anchor mass. The competent authority grants authorisation to the applicant at the earliest 3 months after notifying the Commission provided that the latter does not raise objections.

2. Chapter 2 — Test Procedure

- 2.1. The braking force diagrams in accordance with point 1.3 shall show the braking forces as a function of speed for the reference anchor A and the special anchor B to be authorised on the basis of tests in accordance with points 2.2 to 2.5 below. Annex I shows one possible braking force test.
- 2.2. The reference anchor A used in the tests shall be a conventional folding stockless anchor corresponding to the sketch and details given below, with a mass of at least 400 kg.

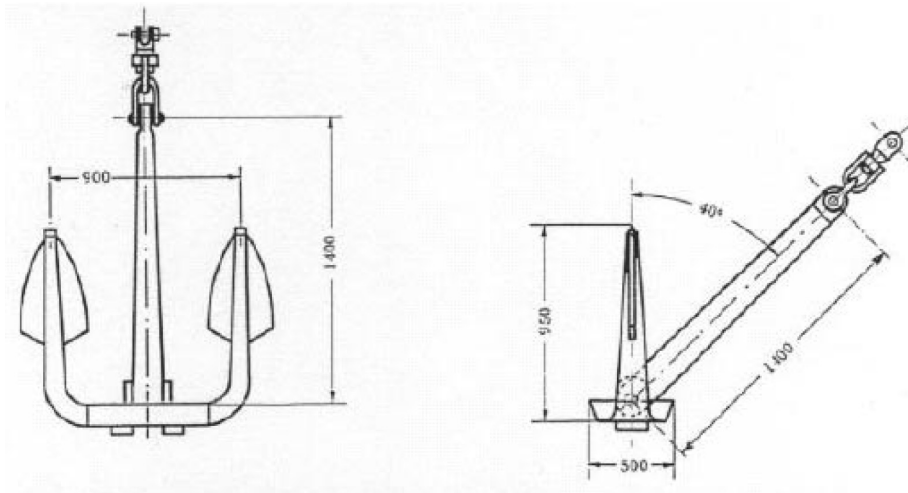

A tolerance of $\pm 5\%$ applies to the dimensions and mass given. However, the surface area of each fluke must be at least $0,15 \text{ m}^2$.

- 2.3. The mass of the special anchor B used in the tests shall not deviate by more than 10% from the mass of the reference anchor A. If the tolerances are greater, the forces shall be recalculated proportional to mass.
- 2.4. Braking force diagrams shall give a linear representation of speed (v) in the range 0 to 5 km/h (speed over ground). To this end, three tests shall be carried out in an upstream direction for the reference anchor A and the special anchor B on an alternating basis over each of two stretches of river determined by the competent authority, one with coarse gravel and one with fine sand. On the River Rhine the stretch between $401\text{--}402 \text{ km}$ can serve as a reference stretch for the coarse gravel tests and the stretch between $480\text{--}481 \text{ km}$ for the fine sand tests.
- 2.5. For each test, the anchor being tested shall be towed with a steel wire cable whose length between the points of connection on the anchor and on the towing craft or device is 10 times the height of the connection point on the craft above the anchorage ground.
- 2.6. The percentage of reduction of anchor mass is calculated by the following formula:

$$r = 75 \cdot \left(1 - 0,5 \frac{PB}{PA} \left(\frac{FA}{FB} + \frac{AA}{AB} \right) \right) [\%]$$

Where

- r the percentage of reduction of anchor mass of special anchor B in relation to reference anchor A;

▼B

- PA the mass of reference anchor A;
 PB the mass of special anchor B;
 FA holding force of reference anchor A at $v = 0,5$ km/h;
 FB holding force of special anchor B at $v = 0,5$ km/h;
 AA the surface area on the braking force diagram defined by:
- the line parallel to the y-axis at $v = 0$,
 - the line parallel to the y-axis at $v = 5$ km/h,
 - the line parallel to the x-axis at holding force $F = 0$,
 - the braking force curve for reference anchor A,

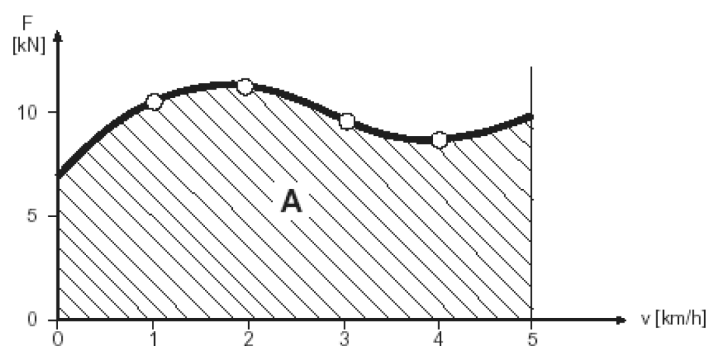
Model braking force diagram

(Determining the surface areas AA and AB)

- AB same definition as for AA except that the braking force curve for special anchor B is used.
- 2.7. The acceptable percentage is the average of six values of r calculated in accordance with point 2.6.



ADMINISTRATIVE INSTRUCTION No 8

Strength of watertight windows

(Article 15.02(16) of Annex II)

1. General

According to Article 15.02(16) of Annex II, watertight windows may be situated below the margin line if they are watertight, cannot be opened, possess sufficient strength and conform to Article 15.06(14).

2. Construction of watertight windows

The requirements of Article 15.02(16) of Annex II are deemed to be fulfilled if the construction of watertight windows complies with the following provisions.

- 2.1. Only pre-stressed glass complying with ISO 614, published 04/94, shall be used.
- 2.2. Round windows shall comply with ISO 1751, published 04/94, Series B: medium heavy-duty windows Type: non-opening window.
- 2.3. Angular windows shall comply with ISO 3903, published 04/94, Series E: heavy-duty windows Type: non-opening window
- 2.4. ISO standard windows may be replaced by windows whose construction is at least equivalent to the requirements of points 2.1 to 2.3.



ADMINISTRATIVE INSTRUCTION No 9

Requirements for automatic pressurised water sprinklers

(Article 10.03a(1) of Annex II)

Suitable automatic pressurised water sprinklers as in Article 10.03a(1) shall meet the following requirements:

1. The automatic pressurised water sprinkler shall be ready for service at all times when there are persons on board. No additional action by crew members shall be required to trigger operation.
2. The system shall be permanently maintained at the necessary pressure. The pipes shall be filled with water up to the spray nozzles at all times. The system shall have a continuously working water supply. It shall not be possible for impurities harmful to operation to enter the system. Appropriate display instruments and test systems (e.g. pressure gauges, pressure-tank water level indicators, pump test piping) shall be installed for monitoring and checking the system.
3. The pump for the water supply to the spray nozzles shall be activated automatically by a pressure drop in the system. The pump shall be dimensioned so that it can continuously provide a sufficient water supply at the necessary pressure if all the spray nozzles necessary for covering the area of the largest room to be protected are activated simultaneously. The pump shall supply the automatic pressurised water sprinkler exclusively. In the event of pump failure, it shall be possible to provide the spray nozzles with a sufficient water supply from another on-board pump.
4. The system shall be divided into sections, each with no more than 50 spray nozzles.
5. The number and the layout of spray nozzles shall ensure effective distribution of water in the rooms to be protected.
6. Spray nozzles shall be triggered at a temperature between 68 °C and 79 °C.
7. The installation of components of automatic pressurised water sprinklers within the rooms to be protected shall be limited to the necessary minimum. No such system components shall be installed in main engine rooms.
8. Visual and acoustic indicators shall be provided in one or more suitable locations, at least one of which must be permanently manned, displaying activation of automatic pressurised water sprinklers for each section.
9. The energy supply of the installation of automatic pressurised water sprinklers shall be provided by two independent energy sources that shall not be installed in the same location. Each energy source shall be capable of supplying the entire system unassisted.
10. An installation plan of the automatic pressurised water sprinkler shall be presented to the inspection body for examination before installation of the system. The plan shall indicate the types and performance data of the machines and equipment used. An installation tested and certified by an approved classification society which complies at least with the above prescriptions can be authorised without further testing.
11. The presence of an automatic pressurised water sprinkler shall be entered in the Community Certificate under item 43.

▼B

ADMINISTRATIVE INSTRUCTION No 10

(Left void)



ADMINISTRATIVE INSTRUCTION No 11

Completion of the Community Certificate

1. GENERAL

1.1. **Forms**

For completion of the Community Certificate only forms authorised by the competent authority shall be used. Forms shall be filled in on one side only.

When issuing a new Community Certificate, all pages 1 to 13 shall be included, even if some pages have no entries.

1.2. **Method of entry**

Entries on the Community Certificate shall be typewritten or computer-printed. Hand written entries may only be made in exceptional cases. The entries shall be indelible. Font colours shall be black or blue only. Deletions shall be made in red.

2. ENTRIES

2.1. **Deletion of alternatives**

Where entries are marked with (*) those which are not appropriate shall be deleted.

2.2. **Items without entry**

If, for any of the items 1 to 48, no entry is either necessary or possible, a line shall be drawn across the entire field.

2.3. **Final page of the Community Certificate**

If no additional pages are required after page 13 (see point 3.2.3), the words “continued on page” (*) at the bottom of page 13 shall be deleted.

2.4. **Amendments**

2.4.1. *First handwritten amendment on a page*

A page can be amended once only, however, several amendments may be made at that time. A red line shall be drawn through any details to be amended. A previously deleted alternative (see point 2.1) or an item previously without entry (see point 2.3) shall be underlined in red. The new details shall not be entered in the amended field, but on the same page under the heading “Amendments”, the line “This page has been replaced” shall be deleted.

2.4.2. *Further handwritten amendments on a page*

For further amendments the page shall be replaced and the necessary amendments as well as any earlier amendments shall be entered directly under the appropriate items. Under the heading “Amendments” the line “amendments to item(s)” shall be deleted.

The old page shall be retained by the inspection body which originally issued the Community Certificate.

2.4.3. *Amendments by electronic data processing*

In case of amendments by electronic data processing, the page shall be replaced and the necessary amendments as well as any earlier amendments shall be entered directly under the appropriate items. Under the heading “Amendments” the line “amendments to item(s)” shall be deleted.

The old page shall be retained by the inspection body which originally issued the Community Certificate.

(*) Delete as appropriate.

▼B**2.5. Corrections by pasting over**

Pasting over of entries or pasting in further details added to an item is not allowed.

3. REPLACING AND ADDING PAGES**3.1. Replacing pages**

Page 1 of the Community Certificate shall never be replaced. For replacing other pages the procedures outlined in point 2.4.2 or point 2.4.3 shall be applied.

3.2. Adding pages

If there is insufficient space for further entries on pages 10, 12 or 13 of the Community Certificate, additional pages may be attached.

3.2.1. Extension/Confirmation of validity

If further extension is necessary when the certificate has already been extended six times, the words "Continued on page 10a" shall be added at the bottom of page 10, and a further page 10 shall be marked as page 10a and inserted after page 10. The respective entry is then made under item 49 at the top of page 10a. At the bottom of page 10a the entry "Continued on page 11" shall be made.

3.2.2. Extension of the liquefied gas installation certificate

A similar procedure to point 3.2.1 shall be applied, with page 12a inserted after page 12.

3.2.3. Annex to the Community Certificate

At the bottom of page 13 the words "End of the Community Certificate" shall be deleted in red, the deleted words "Continued on page (*)" shall be underlined in red and behind that the page number 13a shall be entered. This amendment shall carry an official stamp. A further page 13 shall be marked as page 13a and inserted after page 13. The provisions of points 2.2 and 2.3 apply to page 13a *mutatis mutandis*.

The same procedure shall be applied for any further annexes (pages 13b, 13c, etc.).

4. EXPLANATIONS OF INDIVIDUAL ITEMS

Self-explanatory items are not mentioned below.

2. If applicable, insert terms as per Article 1.01. Other vessel types shall be entered with their commonly accepted designation.

15. This section shall only be completed for craft for which at least one of the properties 1.1 or 1.2 or 3 in item 14 is not deleted, otherwise the entire table shall be deleted.

15.1. In the column "formation figure" of the table the number (s) of the formations depicted shall be entered. Lines without entry shall be struck through.

Further formations may be drawn under "Other formations" and shall be designated 18, 19, 20, etc.

If it is not apparent from the property "fit to push" in the previous ship certificate which formations are authorised, the entry from the previous ship certificate may be transferred to item 52. "See item 52" shall be entered in line 1 of the table "Authorised formations".

15.2. Couplings

Only the details of the coupling between the pushing craft and the pushed section of the convoy shall be entered.

(*) Delete as appropriate.

▼B

- 17-20. Details according to the tonnage certificate items 17-19 to two decimal places and item 20 without decimal places. Length overall and breadth overall give the maximum dimensions of the craft, including all projecting fixed parts. Length L and Breadth B give the maximum hull dimensions (see also Article 1.01 Definitions).
21. Dead weight tonnage for cargo vessels in t according to the tonnage certificate for the maximum draught according to item 19.
- Displacement for all other craft in m³. If no tonnage certificate is available, calculate the displacement from the product of the block coefficient and length L_{WL}, breadth B_{WL} and mean draught at maximum immersion.
23. Number of passenger berths available (including folding beds and similar).
24. Only watertight transverse bulkheads extending from one side of the vessel to the other shall be taken into consideration.
26. If applicable, the following terms shall be used:
- manually operated hatch covers,
 - manually operated rolling hatch covers,
 - manually operated sliding hatch covers,
 - mechanically operated sliding hatch covers,
 - mechanically operated hatch covers.
- Other types of hatch covers shall be entered with their commonly accepted designation.
- Any holds which do not have a hatch cover shall be listed, e.g. under item 52.
28. Figure without decimal place.
- 30, 31 and 33. Every winch housing shall be counted as one winch, regardless of the number of anchors or towing cables connected to it.
34. Under “Other installations” systems which do not use rudder blades (e.g. rudder-propeller, cycloidal-propeller, bow-thruster systems) shall be entered.
- Enter also any electrical auxiliary engines for manual actuation.
- With bow-thruster systems, “remote-controlled” refers only to remote controls operated from the steering position in the wheelhouse.
35. Only the theoretical values according to Article 8.08(2) and (3), Article 15.01(1)(c), and Article 15.08(5) shall be entered, and then only for craft whose keels were laid down after 31 December 1984.
36. A sketch may be necessary for clarification.
37. Only the theoretical values without reduction according to Article 10.01(1)-(4) shall be entered.
38. Only the minimum lengths according to Article 10.01(10) and the minimum tensile strength according to Article 10.01(11) shall be entered.
- 39 and 40. Only the minimum lengths and minimum tensile strength values recalculated according to Article 10.02(2) shall be entered.
42. The inspection body may add items to the list of necessary equipment. These shall be justified as essential to ship safety for the respective vessel type

▼ B

or its operational area. Additions shall be entered under item 52.

Left column, row 3 and 4: for passenger vessels the first mentioned item shall be crossed out and under the second mentioned item the length of the gangway as established by the inspection body shall be entered. For all other vessels the second mentioned item shall be crossed out completely respectively, if the inspection body has allowed a shorter length than what is foreseen by Article 10.02(2)(d), only the first half shall be crossed out and the length of the gangway entered.

Left column, row 6: here the number of the prescribed first aid kits according to Article 10.02(2)(f) and Article 15.08(9) shall be entered.

Left column, row 10: here the number of the prescribed fire proof receptacles according to Article 10.02(1)(d) to (f) shall be entered.

43. Portable fire extinguishers required by other safety regulations, e.g. the regulation for the carriage of dangerous substances on the Rhine (ADNR), are not included here.
44. Row 3: in Community Certificates to be extended before 1.1.2010, or 1.1.2025 where Chapter 24a is applicable, the item “according to EN 395:1998 or 396:1998” shall be crossed if no life vests according to this standard are onboard.
Row 4: when Community Certificates are extended after 1.1.2015, or 1.1.2030 where Chapter 24a is applicable, or if a new dinghy is taken onboard, the item “with a set of oars, one mooring line and a baler” shall be crossed. The item “according to EN 1914:1997” shall be crossed if no dinghy according to this standard is onboard.
46. As a general rule, continuous operation shall not be inserted if there is a lack of berths or if there are excessive noise levels.
50. The expert shall sign only if he has completed page 11 himself.
52. Here any additional restrictions, exemptions and explanations, or similar, applying to entries under individual items can be given.

5. **TRANSITIONAL PROVISIONS**

5.1. **Existing Community Certificates**

With the exception of Article 2.09(2), no further extensions to existing Community Certificates shall be granted.

5.2. **Replacement after a periodical inspection**

After a periodical inspection of a vessel which does not yet have a Community Certificate in line with the model in Annex V Part 1, a Community Certificate shall be issued. Article 2.09(4) and Article 2.17 shall apply.

▼B

ADMINISTRATIVE INSTRUCTION No 12

Fuel tanks on floating equipment

(Article 8.05(1) and Article 17.02(1)(d) of Annex II)

According to Article 8.05(1), fuel tanks shall form an integral part of the hull or shall be firmly attached to it.

Fuel tanks for engines of working gear on floating equipment do not have to form an integral part of the hull or be firmly attached to it. Mobile tanks may be used, provided that they comply with the following conditions:

1. The capacity of these tanks shall not exceed 1 000 litres.
2. It shall be possible to attach the tanks sufficiently firmly and to earth them.
3. The tanks shall be made from steel of a sufficient wall thickness and shall be installed in a drip tray. The latter shall be designed to prevent leaking fuel contaminating the waterways. The drip tray may be dispensed with if double-skin tanks with a leak protection or leakage warning system are used and which are filled only via an automatic delivery valve. The provisions of point 3 shall be deemed to be fulfilled if the construction of a tank has been certified and approved according to the regulations of a Member State.

An appropriate entry shall be made in the Community Certificate.

▼B

ADMINISTRATIVE INSTRUCTION No 13

Minimum hull thickness of barges

(Article 3.02(1) of Annex II)

During periodical inspections in accordance with Article 2.09 of barges which are exclusively towed, the inspection body may allow minor deviations from Article 3.02(1)(b) with respect to the minimum thickness of the shell plating of the hull. The deviation shall not be more than 10 %, and the minimum hull thickness shall not be less than 3 mm.

The deviations shall be entered in the Community Certificate.

Under item 14 of the Community Certificate, only property No 6.2 “Towed as a craft with no motive power of its own” shall apply.

Properties No 1 to 5.3 and 6.1 shall be deleted.

▼B

ADMINISTRATIVE INSTRUCTION No 14

(Left void)

▼B

ADMINISTRATIVE INSTRUCTION No 15

Steerageway under vessel's own power

(Article 10.03b(2)(a), Article 15.07(1), Article 22a.05(1)(a) of Annex II)

1. Minimum requirements for vessel's steerageway

Steerageway under a vessel's own power in accordance with Articles 10.03b(2)(a), 15.07(1) and 22a.05(1)(a) is deemed to be sufficient if — when using the bow thruster — the vessel or the formation propelled by the vessel attains a speed of 6,5 km/h in relation to the water and a rate-of-turn of 20°/min can be induced and maintained while under way at a speed of 6,5 km/h in relation to the water.

2. Navigation tests

On verifying the minimum requirements Articles 5.03 and 5.04 shall be complied with.

▼B

ADMINISTRATIVE INSTRUCTION No 16

(Left void)

▼B

ADMINISTRATIVE INSTRUCTION No 17

Appropriate fire alarm system

(Article 10.03b(3), Article 15.11(17), Article 22b.11(1) of Annex II)

Fire alarm systems are considered to be appropriate if they meet the following conditions.

0. COMPONENTS**0.1. Fire alarm systems consist of:**

- (a) fire detection system,
 - (b) fire indicator system,
 - (c) control panel,
- as well as the external power supply.

0.2. The fire detection system may be divided into one or more fire zones.

0.3. The fire indicator system may have one or more indicator devices.

0.4. The control panel is the central control unit of the fire alarm system. It also includes parts of the fire indicator system (i.e. an indicator device).

0.5. A fire detection zone may have one or more fire detectors.

0.6. Fire detectors may be:

- (a) heat detectors;
- (b) smoke detectors;
- (c) ion detectors;
- (d) flame detectors;
- (e) combination detectors (fire detectors combining two or more of the detectors listed in (a) to (d)).

Fire detectors which respond to other factors indicating the onset of a fire may be approved by the inspection body provided that they are no less sensitive than the detectors referred to under (a) to (e).

0.7. Fire detectors may be installed:

- (a) with or
 - (b) without
- individual identification.

1. CONSTRUCTION REQUIREMENTS**1.1. General**

1.1.1. Compulsory fire alarm systems shall be operational at all times.

1.1.2. Fire detectors required in accordance with point 2.2 shall be automatic. Additional manually operated fire detectors may be installed.

1.1.3. The system and its components shall be able to withstand voltage fluctuations and surges, changes in ambient temperature, vibrations, humidity, shocks, impacts and corrosion such as commonly occur on vessels.

1.2. Energy supply

1.2.1. Energy sources and electric circuits necessary for the operation of the fire alarm system shall be self monitoring. Any fault occurring shall activate a visual and acoustic alarm signal on the control panel which can be distinguished from a fire alarm signal.

▼B

1.2.2. There shall be at least two power sources for the electrical part of the fire alarm system, one of which shall be an emergency power system (i.e. emergency power source and emergency switchboard). There shall be two separate power-feeds solely for this purpose. These shall lead to an automatic switch in or near the control panel of the fire alarm system. On day-trip vessels up to 25 m L_{WL} and on motor vessels a separate emergency power supply is sufficient.

1.3. Fire detection system

1.3.1. Fire detectors shall be grouped in fire detection zones

1.3.2. Fire detection systems shall not be used for any other purpose. By way of derogation the closing of the doors in accordance with Article 15.11(8) and similar functions may be activated and indicated on the control panel.

1.3.3. Fire detection systems shall be designed in such a way that the first indicated fire alarm does not prevent fire alarms set off by other detectors.

1.4 Fire detection zones

1.4.1. Where the fire detectors cannot be remotely identified individually, a fire detection zone shall not monitor more than one deck. This does not apply to a fire detection zone which monitors an encapsulated stairwell.

In order to avoid delays in detecting the origin of the fire, the number of enclosed spaces included in each fire detection zone shall be limited. There shall not be more than fifty enclosed spaces in one fire detection zone.

Where the fire detection system has remote identification of individual fire detectors, the fire detection zones may monitor several decks and any number of enclosed spaces.

1.4.2. On passenger vessels which do not have a fire detection system with remote identification of individual fire detectors, a fire detection zone shall not comprise more than the area constituted in accordance with Article 15.11(10). The activation of a fire detector in an individual cabin in this fire detection zone shall set off a visual and acoustic signal in the passageway outside that cabin.

1.4.3. Galleys, engine rooms and boiler rooms shall constitute separate fire detection zones.

1.5. Fire detectors

1.5.1. Only heat, smoke or ion detectors shall be used as fire detectors. Other types may only be used as additional detectors.

1.5.2. Fire detectors shall be type-approved.

1.5.3. All automatic fire detectors shall be designed in such a way that they can be tested to ensure that they are working properly and brought back into service without having to replace any components.

1.5.4. Smoke detectors shall be set so that they respond to a reduction in visibility per metre caused by smoke of more than 2 % to 12,5 %. Smoke detectors fitted in galleys, engine rooms and boiler rooms shall respond within sensitivity limits meeting the requirements of the inspection body, whereby under-sensitivity or over-sensitivity of the detectors shall be avoided.

1.5.5. Heat detectors shall be set so that with temperature increase rates of less than 1 °C/min they respond at temperatures of between 54 °C and 78 °C.

With higher rates of temperature increase, the heat detector shall respond within temperature limits where under- or over-sensitivity of the heat detector is avoided.

1.5.6. With the agreement of the inspection body, the permissible operating temperature of heat detectors may be increased to 30 °C above the maximum temperature in the upper part of engine and boiler rooms.

1.5.7. The sensitivity of flame detectors shall be sufficient to detect flames against an illuminated background. Flame detectors shall also be equipped with a system for identifying false alarms.

▼B**1.6. Fire detection system and control panel**

- 1.6.1. Activation of a fire detector shall set off a visual and acoustic fire alarm signal at the control panel and the indicator devices.
- 1.6.2. The control panel and the indicator devices shall be at a location which is permanently manned by crew or shipboard personnel. One indicator shall be at the steering position.
- 1.6.3. The indicator devices shall indicate at least the fire detection zone in which a fire detector has been activated.
- 1.6.4. On or near each indicator device there shall be clear information on the areas monitored and the location of the fire detection zones.

2. INSTALLATION REQUIREMENTS

- 2.1. Fire detectors shall be installed in such a manner as to ensure the best possible operation of the system. Locations in the vicinity of deck girders and ventilation shafts or other locations where air currents could adversely affect system operation and locations where impacts or mechanical damage are likely shall be avoided.
- 2.2. In general, fire detectors located on the ceiling shall be at least 0,5 metres away from bulkheads. The maximum distance between fire detectors and bulkheads shall conform to the following table:

Type of fire detector	Maximum floor surface area per fire detector	Maximum distance between fire detectors	Maximum distance of fire detectors from bulkheads
Heat	37 m ²	9 m	4,5 m
Smoke	74 m ²	11 m	5,5 m

The inspection body may stipulate or approve other distances on the basis of tests which prove the characteristics of the detectors.

- 2.3. The routing of electric cables for the fire alarm system through engine rooms and boiler rooms or other high fire risk areas is not permitted unless this is necessary for fire detection in those areas or connection to the corresponding power supply.

3. TESTING

- 3.1. Fire alarm systems shall be tested by an expert:
- (a) after installation;
- (b) regularly, but at least every two years.

In the case of engine rooms and boiler rooms these tests shall be carried out under varying operational and ventilation conditions.

- 3.2. A test certificate shall be signed by the expert, indicating the date of the test.

▼B

ADMINISTRATIVE INSTRUCTION No 18

Proof of buoyancy, trim and stability of the separated parts of a vessel

(Article 22a.05(2), in conjunction with Article 22.02 and Article 22.03 of Annex II)

1. When proving the buoyancy, trim and stability of the parts of a vessel which have been separated in accordance with Article 22a.05(2)(a), it shall be assumed that both parts were partly or fully unloaded beforehand or That containers extending beyond the hatch coaming were suitably protected from slipping.
2. For each of the two parts, the following requirements shall therefore be met when calculating stability in accordance with Article 22.03 (Limit conditions and method of calculation for confirmation of stability for the transport of secured containers):
 - metacentric height MG shall be not less than 0,50 m,
 - there shall be a residual safety clearance of 100 mm,
 - the speed to be taken into account shall be 7 km/h,
 - the wind pressure shall be taken to be 0,01 t/m².
3. The heeling angle ($\leq 5^\circ$) does not have to be complied with for the parts of the vessel separated in accordance with Article 22a.05(2) since this angle — derived from the coefficient of friction — was specified for non-secured containers.

The heeling lever resulting from the free surfaces of liquids shall be taken into account in accordance with the formula given in Article 22.02(1)(e).
4. The requirements set out in points 2 and 3 shall also be deemed to have been met if, for each of the two parts, the stability requirements set out in Section 9.1.0.95.2 of the Ordinance on the transportation of hazardous goods on the Rhine (ADNR) are met.
5. Confirmation of the stability of the separated parts of the vessel may be obtained on the assumption that the load is evenly distributed, as an even distribution of the load — as far as it is not already the case — can be done prior to separation, or else the vessel can be largely unloaded.

▼B

ADMINISTRATIVE INSTRUCTION No 19

(Left void)



ADMINISTRATIVE INSTRUCTION No 20

Equipment for vessels to be operated according to standards S1 and S2

(Article 23.09 of Annex II)

1. GENERAL INTRODUCTION

According to Article 23.09(1) of Annex II, vessels which are intended to be operated according to standards S1 and S2 shall comply with the provisions of this Article. According to Article 23.09(1) the inspection body shall confirm in the Community Certificate that the vessel complies with these provisions.

These provisions are supplementary equipment requirements which apply in addition to the requirements with which a vessel has to comply for the Community Certificate to be issued. Provisions of Article 23.09 which might be interpreted in different ways will be clarified in this Administrative instruction. Accordingly, the provisions of Article 23.09(1) of Annex II shall be interpreted as follows:

2. ARTICLE 23.09

2.1. **(1.1)(a) — Arrangement of the propulsion system**

If a vessel is fitted with a directly reversible main engine, the compressed air system which is required to reverse the direction of thrust shall:

- (a) be kept permanently pressurised by an automatically adjusting compressor; or
- (b) when an alarm is triggered in the wheelhouse be pressurised by means of an auxiliary engine which can be started from the steering position. If the auxiliary engine has its own fuel tank, there shall — in accordance with Article 8.05(13) — be a warning device in the wheelhouse to indicate if the level of filling is not sufficient to ensure further safe operation.

2.2. **(1.1)(b) — Bilge levels in the main engine room**

If a bow steering system is necessary to comply with the manoeuvring requirements of Chapter 5, the room containing the bow steering system shall be deemed to be a main engine room.

2.3. **(1.1)(c) — Automatic fuel supply**

2.3.1. If the propulsion system has a daily-supply tank,

- (a) its contents shall be sufficient to ensure an operation period of the propulsion system of 24 hours, assuming a consumption of 0,25 litres per kW per hour;
- (b) the fuel supply pump for refilling the daily-supply tank shall be operated continuously; or
- (c) the fuel supply pump shall be fitted with:
 - a switch that automatically switches on the fuel supply pump when the daily-supply tank reaches a certain low level, and
 - a switch that automatically switches off the fuel supply pump when the daily-supply tank is full.

2.3.2. The daily-supply tank shall have a level alarm device which meets the requirements of Article 8.05(13).

2.4. **(1.1)(d) — No particular force required for the steering system**

Hydraulically operated steering systems fulfil this requirement. Manually operated steering systems shall not require a force of more than 160 N in order to be operated.

▼B

- 2.5. **(1.1)(e) — Visual and acoustic signals required under way**
 Visual signs do not include cylinders, balls, cones or double cones required under navigational authority regulations of the Member States.
- 2.6. **(1.1)(f) — Direct communication and communication with the engine room**
- 2.6.1. Direct communication shall be deemed to be ensured if:
- (a) direct visual contact is possible between the wheelhouse and the control positions for the winches and bollards on the fore section or the stern of the vessel and in addition the distance from the wheelhouse to these control positions is not more than 35 m; and
 - (b) the accommodation is directly accessible from the wheelhouse.
- 2.6.2. Communication with the engine room shall be deemed to be ensured if the signal referred to in Article 7.09(3) second sentence, can be operated independently from the switch referred to in Article 7.09(2).
- 2.7. **(1.1)(i) — Cranks and similar rotating means of operation**
 These include:
- (a) manually operated anchor winches (the maximum force required shall be deemed to be that when the anchors are hanging freely);
 - (b) cranks for lifting hatches;
 - (c) cranks on mast and funnel winches.
- These do not include:
- (a) warping and coupling winches;
 - (b) cranks on cranes, unless intended for ship's boats.
- 2.8. **(1.1)(m) — Ergonomic arrangement**
 The provisions are deemed to be fulfilled if:
- (a) the wheelhouse is arranged in accordance with European Standard EN 1864:2008; or
 - (b) the wheelhouse is designed for radar navigation by one person; or
 - (c) the wheelhouse meets the following requirements:
 - (aa) the control units and monitoring instruments are in the forward field of vision and within an arc of not more than 180° (90° to starboard and 90° to port), including the floor and ceiling. They shall be clearly legible and visible from the normal position of the helmsman;
 - (bb) the main control units such as the steering wheel or steering lever, the engine controls, the radio controls, and the controls for the acoustic signals and the warning and manoeuvring signals required under national or international navigational authority regulations, as appropriate, shall be arranged in such a way that the distance between the controls on the starboard side and those on the port side is not more than 3 m. The helmsman shall be able to operate the engines without letting go of the controls for the steering system and while still being able to operate the other controls such as the radio system, the controls for the acoustic signals and the warning and manoeuvring signals required under national or international navigational authority regulations, as appropriate;
 - (cc) the warning and manoeuvring signals required under national or international navigational authority regulations, as appropriate, are operated electrically, pneumatically, hydraulically or mechanically. By way of derogation, it may be operated by means of a tension wire only if safe operation from the steering position is possible in this way.

▼B

3. ARTICLE 23.09

3.1. **(1.2)(a) — Motor vessel operating separately**

Motor vessels which according to the Community Certificate are also suitable for pushing but which:

- (a) do not have hydraulically or electrically operated coupling winches;
or
 - (b) whose hydraulically or electrically operated coupling winches do not meet the requirements of point 3.3 of this Administrative instruction,
- shall be given the standard S2 as motor vessel operating separately.

The entry “Standard S2 does not apply to the motor vessel when pushing” shall be entered under item 47 of the Community Certificate.

3.2. **(1.2)(c) — Pushed convoys**

Motor vessels which according to their Community Certificate are suitable for pushing and are fitted with hydraulically or electrically operated coupling winches that fulfil the requirements of point 3.3 of this Administrative instruction but which do not have their own bow thruster shall be given the standard S2 as motor vessel pushing a convoy. The entry “Standard S2 does not apply to the motor vessel when operating separately” shall be entered under item 47 of the Community Certificate.

3.3. **(1.2)(c), first sentence, and (1.2)(d), first sentence — Special winches or equivalent devices for tensioning the cables (coupling devices)**

The coupling devices required are the minimum equipment specified in accordance with Article 16.01(2) which, according to points 2.1 and 2.2 of Administrative instruction No 3 (longitudinal connections), serve to take up the coupling forces and which meet the following requirements:

- (a) the device shall provide the tensioning force required for the coupling only by mechanical means;
- (b) the controls for the device shall be located on the device itself. By way of derogation, remote control is permitted provided that:
 - the person operating the device has an unobstructed direct view of the device from the control position,
 - there is a device at the control position to prevent unintentional operation,
 - the device has an emergency stop;
- (c) the device shall have a braking device which acts immediately if the controls are released or the motive force fails;
- (d) it shall be possible for the coupling cable to be released manually if the motive force fails.

3.4. **(1.2)(c), second sentence, and (1.2)(d), second sentence — Operating the bow thruster**

The control for operating the bow thruster shall be permanently installed in the wheelhouse. The requirements of Article 7.04(8) shall be complied with. The electric cabling to operate the bow thruster shall be permanently installed up to the fore section of the pushing motor vessel or the pusher.

3.5. **(1.2)(e) — Equivalent manoeuvrability**

Equivalent manoeuvrability is ensured by a propulsion system consisting of:

- (a) a multi-propeller drive and at least two independent propulsion systems with similar power output;
- (b) at least one cycloidal propeller;
- (c) at least one rudder propeller; or
- (d) at least one 360° water-jet propulsion system.



ADMINISTRATIVE INSTRUCTION No 21

Requirements for low-location lighting

(Article 15.06(7); Article 22b.10(d) of Annex II)

1. General

- 1.1. According to the abovementioned provisions, passenger vessels and high-speed vessels shall have suitable systems to clearly identify the escape routes and emergency exits when the normal emergency lighting is less effective due to smoke. Such systems shall take the form of low-location lighting (LLL). This Administrative instruction covers the approval, installation and maintenance of such systems.
- 1.2. In addition to the emergency lighting required by Article 15.10(3) the escape routes, including stairways, exits and emergency exits, shall be marked by low-location lighting (LLL) throughout the whole of the escape route, particularly at corners and intersections.
- 1.3. The LLL system shall function for at least 30 minutes after its activation.
- 1.4. LLL products shall be neither radioactive nor toxic.
- 1.5. Instructions on the LLL system shall be displayed with the safety plan in accordance with Article 15.13(2) and in every cabin.

2. Definitions

- 2.1. Low-location lighting (LLL) — Electrically powered lighting or photoluminescent indicators placed along the escape routes so as to ensure that all such routes can be easily identified.
- 2.2. Photoluminescent (PL) system — An LLL system which uses PL material. Photoluminescent material contains a chemical (example: zinc sulphide) that has the quality of storing energy when illuminated by visible light. The PL material emits light which becomes visible when the ambient light source is less effective. Without the light source to re-energise it, the PL material gives off the stored energy for a period of time with diminishing luminance.
- 2.3. Electrically powered (EP) system — An LLL system which requires electrical power for its operation, such as systems using incandescent bulbs, light-emitting diodes, electroluminescent strips or lamps, electrofluorescent lamps, etc.

3. Passageways and stairways

- 3.1. In all passageways, the LLL shall be continuous, except where interrupted by corridors and cabin doors, in order to provide a visible delineation along the escape route. LLL systems in compliance with an international standard having a visible delineation without being continuous shall also be acceptable. The LLL shall be installed at least on one side of the corridor, either on the wall no more than 0,3 m from the floor, or on the floor no more than 0,15 m from the wall. In corridors more than two metres wide, LLL shall be installed on both sides.
- 3.2. In dead-end corridors, the LLL shall have arrows placed at intervals of no more than 1 m, or equivalent direction indicators, pointing in the direction of the escape route.
- 3.3. In all stairways, LLL shall be installed on at least one side at no more than 0,3 m above the steps, which will make the location of each step readily identifiable to any person standing above and below that step. Low-location lighting shall be installed on both sides if the width of the stairway is two metres or more. The top and bottom of each set of stairs shall be identified to show that there are no further steps.

▼ B**4. Doors**

- 4.1. Low-location lighting shall lead to the exit door handle. To prevent confusion, no other doors shall be similarly marked.
- 4.2. Where sliding doors are fitted in partitions in accordance with Article 15.11(2) and in bulkheads in accordance with Article 15.02(5), the direction of opening shall be indicated.

5. Signs and markings

- 5.1. All escape route signs shall be of photoluminescent material or marked by electric lighting. The dimensions of such signs and markings shall be commensurate with the rest of the LLL system.
- 5.2. Low-location lighting exit signs shall be provided at all exits. The signs shall be located within the prescribed area on the side of the exit doors where the handle is located.
- 5.3. All signs shall contrast in colour to the background (wall or floor) on which they are installed.
- 5.4. Standardised symbols (for example those described in IMO Decision A.760(18)) shall be used for the LLL.

6. Photoluminescent systems

- 6.1. PL strips shall be no less than 0,075 m wide. Narrower strips may however be used if their luminance is increased proportionally to compensate for their width.
- 6.2. Photoluminescent materials shall provide at least 15 mcd/m² measured 10 minutes after the removal of all external illuminating sources. The system shall then continue to provide luminance values greater than 2 mcd/m² for 20 minutes.
- 6.3. Any PL system materials shall be provided with not less than the minimum level of ambient light necessary to charge the PL material to meet the above luminance requirements.

7. Electrically powered systems

- 7.1. Electrically powered systems shall be connected to the emergency switchboard required by Article 15.10(4) so as to be powered by the main source of electrical power under normal circumstances and also by the emergency source of electrical power when the latter is in operation. For the purpose of dimensioning the capacity of the emergency source of electrical power the EP systems shall be included in the list of emergency consumers.
- 7.2. Electrically powered systems shall either switch on automatically or be capable of being activated by means of a single operation at the steering position.
- 7.3. Where electrically powered systems are installed, the following standards of luminance shall be applied:
 1. the active parts of electrically powered systems shall have a minimum luminance of 10 cd/m²;
 2. the point sources of miniature incandescent lamps shall provide not less than 150 mcd mean spherical intensity with a spacing of not more than 0,1 m between lamps;
 3. the point sources of light-emitting-diode systems shall have a minimum peak intensity of 35 mcd. The angle of half-intensity cone shall be appropriate to the likely track directions of approach and viewing. Spacing between lamps shall be no more than 0,3 m; and
 4. for electroluminescent systems, these shall function for 30 minutes from the instant when the main power supply to which it was required to be connected by Section 7.1 fails.

▼B

- 7.4. All EP systems shall be arranged so that the failure of any single light, lighting strip, or battery will not result in the marking being ineffective.
- 7.5. Electrically powered systems shall meet the requirements of Article 9.20 for vibration and heat testing. By way of derogation from Article 9.20(2)(c) the heat test may be conducted at a reference ambient temperature of 40 °C.
- 7.6. Electrically powered systems shall meet the electromagnetic compatibility requirements laid down in Article 9.21.
- 7.7. Electrically powered systems shall provide a type of minimum protection of IP 55 in accordance with IEC 60529:1992.

8. Tests

LLL systems shall have their luminance tested by an expert at least once every five years. A test certificate shall be signed by the expert, indicating the date of the test. If the luminance for a particular reading does not meet the requirements of this Administrative instruction, readings shall be taken in at least ten locations equally spaced apart. If more than 30 % of the readings do not meet the requirements of this Administrative instruction, the LLL shall be replaced. If between 20 % and 30 % of the readings do not meet the requirements of this Administrative instruction, the LLL shall be checked again within one year.



ADMINISTRATIVE INSTRUCTION No 22

Specific safety needs of persons with reduced mobility

(Article 1.01(104), Article 15.01(4), Article 15.06(3) to (5), (9), (10), (13) and (17), Article 15.08(3), Article 15.10(3), Article 15.13(1) to (4) of Annex II)

1. Introduction

Persons with reduced mobility have safety needs exceeding those of other passengers. These needs are taken into account in the requirements of Chapter 15, which are explained as follows.

These requirements are intended to ensure that persons with reduced mobility can stay and move safely on board vessels. In addition, in an emergency such persons should have the same level of safety as other passengers.

It is not necessary that all passenger areas fulfil the specific safety requirements of persons with reduced mobility. Therefore those requirements apply only to certain areas. However, the persons in question must be given the opportunity of being informed of the areas specially adapted for them in view of safety, so that they can organise their stay on board accordingly. It is the responsibility of the ship-owner to make the corresponding areas available, make them known and communicate them to persons with reduced mobility.

The provisions concerning persons with reduced mobility make reference to:

- Directive 2003/24/EC of the European Parliament and of the Council of 14 April 2003 amending Council Directive 98/18/EC on safety rules and standards for passenger ships, and
- the guide for the adaptation of inland waterway passenger vessels to people with disabilities in accordance with Resolution No 25 of the United Nations Economic Commission for Europe.

The definition of the term “persons with reduced mobility” used in Annex II is largely identical to that of the Directive and most of the technical requirements are based on the guide. In cases of doubt, therefore, both can be referred to when taking decisions. In general, the requirements of the Directive and guide go beyond those of Annex II.

The requirements of Annex II do not concern berths and similar installations. These are subject to national provisions.

2. Article 1.01(104) — Term “Persons with reduced mobility”

“Persons with reduced mobility” means anyone who, as a result of physical impairments, cannot move or distinguish their surroundings in the same way as other passengers. This definition includes persons with impaired eyesight or hearing or persons accompanying children in buggies or being carried. However, for the purposes of these provisions, persons with reduced mobility do not include anyone with psychic impairments.

3. Article 15.01(4) — General provisions: Areas provided for use by persons with reduced mobility

Areas provided for use by persons with reduced mobility range from, in the simplest case, the entrance area to the places from which an evacuation will take place in an emergency. They shall include:

- a place where life-saving equipment is stowed or issued in an emergency,
- seats,
- a suitably-adapted toilet (No 10 of these guidelines), and
- connecting corridors.

The number of seats corresponds at least approximately to the number of persons with reduced mobility that — over a lengthy period — are most frequently onboard simultaneously. The number should be determined by

▼B

the ship-owner on the basis of experience, as this is beyond the knowledge of the competent authority.

On cabin vessels consideration shall also be given to connecting corridors to passenger cabins used by persons with reduced mobility. The number of such cabins is to be determined by the ship-owner in the same way as the number of seats. With the exception of the width of doors, no requirements are imposed for the special arrangement of cabins. It is the responsibility of the owner to make any further necessary arrangements.

Sentence 2 is identical to Article 24.04(4), taking into account the special safety requirements of persons with reduced mobility. It shall therefore be applied likewise. Should the recommendations require alternative measures, these may in particular be of organisational nature.

4. **Article 15.06(3)(g) — Exits of rooms**

With regard to the requirements concerning the width of connecting corridors, exits and openings in bulwarks or guard rails intended for use by persons with reduced mobility or usually used for the embarkation or disembarkation of persons with reduced mobility, consideration shall be given to buggies and the fact that people may be dependent on various types of walking aids or wheelchairs. In the case of exits or openings for embarkation or disembarkation account shall also be taken of the additional space needed for any assisting staff.

5. **Article 15.06(4)(d) — Doors**

The requirements regarding the arrangement of the area surrounding doors intended for use by persons with reduced mobility shall ensure that persons dependent for example on walking aids can open such doors safely.

6. **Article 15.06(5)(c) — Connecting corridors**

See point 4 of this Administrative instruction.

7. **Article 15.06(9) — Stairways and elevators**

The requirements for the arrangement of stairways shall, in addition to possible reduced mobility, also take into account eyesight impediments.

8. **Article 15.06(10)(a) and (b) — Bulwarks and guard rails**

The requirements for bulwarks and guard rails of decks intended for use by persons with reduced mobility shall provide for a greater height since such persons are more likely to lose their balance or be unable to hold on by themselves.

See also point 4 of this Administrative instruction.

9. **Article 15.06(13) — Traffic areas**

For various reasons, persons with reduced mobility need to support themselves or hold on more frequently, so walls in traffic areas intended for use by persons with reduced mobility shall be equipped with handrails at an appropriate height.

See also point 4 of this Administrative instruction

10. **Article 15.06(17) — Toilets**

Persons with reduced mobility shall also be able to stay and move safely in toilets, so at least one toilet shall be adapted accordingly.

11. **Article 15.08(3)(a and b) — Alarm system**

Persons with reduced mobility are more likely to encounter situations in which they are dependent on the help of others. In rooms in which, as a general rule, they cannot be seen by crew members, on-board personnel or passengers, the possibility of triggering an alarm should therefore be provided for. This applies to toilets intended for use by persons with reduced mobility.

▼B

Persons with reduced mobility include persons with impaired eyesight or hearing. Consequently, at least in areas intended for use by persons with reduced mobility, the passenger alarm system shall provide suitable visual and audible alarms.

12. Article 15.10(3)(d) — Sufficient lighting

Persons with reduced mobility also include persons with impaired eyesight. Sufficient lighting in areas intended for use by persons with reduced mobility is therefore essential and shall meet higher requirements than lighting for other passenger areas.

13. Article 15.13(1) — Safety rota

The special safety measures necessary for persons with reduced mobility to be taken into consideration in the safety rota shall take into account both the possibility of reduced mobility and impaired hearing and eyesight. For such persons measures for normal operation shall be taken into account in addition to measures in the event of emergencies.

14. Article 15.13(2) — Safety plan

The areas covered by point 3 of this Administrative instruction shall be designated.

15. Article 15.13(3)(b) — Displaying the safety rota and the safety plan

At least the copies of the safety rota and the safety plan displayed in the areas intended for use by persons with reduced mobility shall be such that they can, where possible, also be read by persons with impaired eyesight. This can be achieved for example by appropriate use of contrast and character size.

In addition, the plans shall be displayed at a height so that wheelchair users can read them as well.

16. Article 15.13(4) — Code of conduct for passengers

Point 15 of this Administrative instruction applies accordingly

▼B

ADMINISTRATIVE INSTRUCTION No 23

(Left void)



ADMINISTRATIVE INSTRUCTION No 24

Suitable gas warning equipment

(Article 15.15(9) of Annex II)

1. In accordance with Sections 24.02(2) and 24.06(5) (in each case transitional provision to Section 15.01(2)(e)) liquefied petroleum gas (LPG) systems for household purposes on board existing passenger vessels may only be operated until the first renewal of the Community Certificate after 1 January 2045, on condition that a gas warning equipment in accordance with Section 15.15(9) is available. In accordance with Section 15.15(9), LPG systems for household purposes may in the future also be installed on passenger vessels put into operation for the first time and of which the length does not exceed 45 m, if such warning equipment is installed at the same time.
2. In accordance with Sections 24.02(2) and 24.06(5) (in each case transitional provision to Section 15.15(9)) this gas warning equipment shall be installed on the first renewal of the certificate in accordance with Section 14.15.
3. The gas warning equipment consists of sensors, equipment and pipes and shall be considered suitable if it at least meets the following prescribed requirements:
 - 3.1. Requirements to be met by the system (sensors, equipment, pipes):
 - 3.1.1. Gas warning shall be given at the latest when reaching or exceeding one of the following values:
 - (a) 10 % lower explosion limit (LEL) of a propane-air mixture; and
 - (b) 30 ppm CO (carbon monoxide).
 - 3.1.2. The time until activation of the alarm for the whole system must not exceed 20 s.
 - 3.1.3. The limit values mentioned in numbers 3.1.1 and 3.1.2 must not be adjustable.
 - 3.1.4. The test gas production shall be so designed that any interruption or obstruction is detected. Any falsification due to air admission or loss of test gas as a consequence of leakage shall be avoided or detected and reported.
 - 3.1.5. The equipment shall be designed for temperatures ranging from -10 to 40° C and an air humidity ranging from 20 to 100 %.
 - 3.1.6. The gas warning equipment must be self-monitoring. It shall be impossible to switch off the equipment unauthorised.
 - 3.1.7. Gas warning equipment supplied by the onboard power supply network shall be buffered against power failure. Battery-powered appliances shall be provided with a warning device indicating a reduction of the battery voltage.
 - 3.2. Requirements to be met by the equipment:
 - 3.2.1. The equipment shall consist of an evaluation and display unit.
 - 3.2.2. The alarm indicating that the limit values in points 3.1.1(a) and (b) have been reached or exceeded shall be given optically and acoustically, both in the room monitored and in the wheelhouse or at any other permanently manned location. It shall be clearly visible and audible even in operating conditions with the highest noise level. It shall be clearly distinguishable from any other acoustic and optical signals in the room to be protected. The acoustic alarm shall also be clearly audible with closed connecting doors at the entrances and in neighbouring rooms. The acoustic alarm may be silenced after activation, the optical alarm may only be cancelled if the limit values fall below those given mentioned in point 3.1.1.
 - 3.2.3. It shall be possible to separately detect and clearly assign the reports indicating that the limit values in points 3.1.1(a) and (b) have been reached or exceeded.
 - 3.2.4. If the appliance has a special status (start-up, failure, calibration, parameterisation, maintenance etc.), this shall be indicated. The failure of the

▼B

whole system or one of the components shall be indicated by an alarm in analogy to point 3.2.2. The acoustic alarm may be silenced after activation, the optical alarm may only be cancelled if the failure is removed.

- 3.2.5. If it is possible to issue different reports (limit values, special status) it shall also be possible to discern them separately and to assign them clearly. If necessary, a collective signal shall be displayed indicating that it is not possible to issue all reports. In this case, the reports shall be issued by order of priority, beginning with the report with the highest safety relevance. The display of the reports which cannot be issued shall be possible by pressing a button. The order of priority shall be evident from the documentation of the appliance.
- 3.2.6. The equipment shall be so designed that unauthorised interference is not possible.
- 3.2.7. In all cases where detection and alarm equipment are used, the control alarm unit and indicating device shall be operable from outside the spaces containing the gas storage and consuming appliances.
- 3.3. Requirements to be met by the sensors/sampling devices:
 - 3.3.1. In every room with consuming appliances, sensors of the gas warning equipment shall be provided in the vicinity of these appliances. The sensors/sampling devices shall be installed in such a way that gas accumulation is detected before the limit values mentioned in point 3.1.1 are reached. Arrangement and installation of the sensors shall be documented. The selection of the locations shall be substantiated by the manufacturer or the specialised firm installing the equipment. The pipes of the sampling devices should be as short as possible.
 - 3.3.2. The sensors shall be easily accessible in order to enable regular calibration, maintenance and safety checks.
- 3.4. Requirements to be met by the installation:
 - 3.4.1. The whole gas warning equipment shall be installed by a specialised firm.
 - 3.4.2. For the installation, the following aspects shall be taken into consideration:
 - (a) local ventilation systems;
 - (b) structural arrangements (design of walls, partitions etc.) facilitating or complicating the accumulation of gases; and
 - (c) prevention of adverse effects due to mechanical damage, water or heat damage.
 - 3.4.3. All pipes of the sampling devices shall be arranged in such a way that condensate formation is not possible.
 - 3.4.4. The installation shall be effected in such a way that any unauthorised tampering is not possible.
4. Calibration/inspection of the equipment
 - 4.1. Before the starting-up of the gas warning equipment, it shall be calibrated in accordance with the manufacturer's details.
 - 4.2. The gas warning equipment shall be regularly calibrated and inspected by an approved expert or an expert in accordance with the manufacturer's details. An inspection certificate shall be issued, signed by the approved expert or an expert in accordance with the manufacturer's details and showing the date of the inspection.
 - 4.3. Elements of the gas warning equipment with limited lifespan shall be replaced in due time before the expiry of the expected lifespan.
5. Marking
 - 5.1. All appliances shall at least show the following information in a clearly legible and indelible form:
 - (a) name and address of the manufacturer;
 - (b) legal marking;
 - (c) designation of series and type;
 - (d) if possible, serial number;

▼ B

- (e) if required, any advice indispensable for safe use; and
 - (f) for each sensor the indication of the calibration gas.
- 5.2. Elements of the gas warning equipment with limited restricted lifespan shall be clearly marked as such.
6. Manufacturer's details relating to the gas warning equipment:
- (a) complete instructions, drawings and diagrams concerning the safe and proper operation as well as the installation, starting-up and maintenance of the gas warning equipment;
 - (b) operating instructions containing at least:
 - (aa) measures to be taken in the case of an alarm or error indication;
 - (bb) safety measures in the case of non-availability (e.g. calibration, inspection, interruption); and
 - (cc) persons responsible for installation and maintenance;
 - (c) instructions for calibration before the starting-up, and for routine calibration, including time intervals to be followed;
 - (d) supply voltage;
 - (e) type and meaning of the alarms and displays (e.g. special status);
 - (f) information concerning the detection of operating difficulties and the removal of faults;
 - (g) type and scope of the replacement of components with limited lifespan; and
 - (h) type, scope and time interval of the inspections.



ADMINISTRATIVE INSTRUCTION No 25

Electric cables

(Article 9.15 and 15.10(6) of Annex II)

General (all vessels) — Article 9.15

1. When applying Article 9.15, Section 5, reduced ventilation of shielded cables or cables in totally enclosed trunks has to be taken into account.
2. In Article 9.15, Section 9 the number of cable joints should be kept to a minimum. They may be used for repair or replacement purposes as well as, exceptionally, for the simplification of installation. Cable joints made in accordance with 3.28 and Annex D to IEC 60092-352:2005, or equivalent regulations recognised by one of the Member States, will be considered acceptable.

Passenger vessels — Article 15.10(6)

1. On passenger vessels, cables and cable routing are considered to be satisfactory if they meet the conditions in 2 and 3.
2. For cables providing power in an emergency to equipment listed in Article 15.10, Section 4, compliance with Article 15.10, Section 6 second paragraph will require that:
 - (a) the cables are run in such a manner as to avoid being rendered unserviceable by heating of the bulkheads and decks that may be caused by a fire in an adjacent space;
 - (b) where the cables supply equipment located within high fire risk areas, the cable runs within such areas must avoid routes which pass over or near the top of diesel engines and oil-fired equipment, or near to hot surfaces e.g. diesel engine exhaust systems. Where there is no alternative route, cables must be protected from heat and fire damage. Such fire protection could be in the form of a steel plate or trunk;
 - (c) the cables and associated equipment supplied from the emergency source of power should, as far as practicable, be kept within the safe area;
 - (d) cable systems are arranged so that fire in any area bounded by Type A partitions as shown in Article 15.11, Section 2 will not interfere with services essential for safety in any other such area. This requirement will be met if main and emergency cables do not pass through the same area. If they pass through the same area, the requirement will be met if:
 - (aa) they are separated as wide as is practicable; or
 - (bb) the emergency cable is of the fire resistant type.
3. Consideration should be given to the arrangements of bunched cable runs to ensure that the flame-retardant characteristics of the cables are not impaired. This requirement is met if the cables are in accordance with IEC 60332-3:2000. If compliance with IEC 60332-3:2000, or equivalent regulations recognised by one of the Member States, is not met, fire stops in long runs of bunched cables (over 6 m vertical and 14 m horizontal) should be considered, unless the cables are totally enclosed in cable trunks. The use of unsuitable paints, trunking and casings may significantly affect the fire propagation characteristics of cables and shall be avoided. The use of special types of cables such as radio frequency cables may be permitted without complying with the foregoing.