

Directive 2009/62/EC of the European Parliament and of the Council of 13 July 2009 relating to the space for mounting the rear registration plate of two or three-wheel motor vehicles (Codified version) (Text with EEA relevance) (repealed)

DIRECTIVE 2009/62/EC OF THE EUROPEAN
PARLIAMENT AND OF THE COUNCIL

of 13 July 2009

relating to the space for mounting the rear registration
plate of two or three-wheel motor vehicles

(Codified version)

(Text with EEA relevance) (repealed)

THE EUROPEAN PARLIAMENT AND THE COUNCIL OF THE EUROPEAN UNION,

Having regard to the Treaty establishing the European Community, and in particular Article 95 thereof,

Having regard to the proposal from the Commission,

Having regard to the Opinion of the European Economic and Social Committee⁽¹⁾,

Acting in accordance with the procedure laid down in Article 251 of the Treaty⁽²⁾,

Whereas:

- (1) Council Directive 93/94/EEC of 29 October 1993 relating to the space for mounting the rear registration plate of two or three-wheel vehicles⁽³⁾ has been substantially amended⁽⁴⁾. In the interests of clarity and rationality the said Directive should be codified.
- (2) Directive 93/94/EEC is one of the separate Directives of the EC type-approval system provided for in Council Directive 92/61/EEC of 30 June 1992 relating to the type-approval of two or three-wheel motor vehicles as replaced by Directive 2002/24/EC of the European Parliament and of the Council of 18 March 2002 relating to the type-approval of two or three-wheel motor vehicles⁽⁵⁾ and lays down technical prescriptions concerning the design and construction of two or three-wheel vehicles as regards the space for mounting the rear registration plate. Those technical prescriptions concern the approximation of the laws of the Member States to allow for the EC type-approval procedure provided for in Directive 2002/24/EC to be applied in respect of each type of vehicle. Consequently, the provisions laid down in Directive 2002/24/EC relating to vehicle systems, components and separate technical units apply to this Directive.
- (3) The objective of this Directive is not to harmonise the dimensions of registration plates used in the various Member States. The Member States should therefore ensure that protruding registration plates do not constitute a danger for users, without, however, this requiring any modification with regard to vehicle construction.

- (4) This Directive should be without prejudice to the obligations of the Member States relating to the time-limits for transposition into national law and application of the Directives set out in Annex II, Part B,

HAVE ADOPTED THIS DIRECTIVE:

Article 1

This Directive shall apply to the space for mounting the rear registration plate of all types of motor vehicles as defined in Article 1 of Directive 2002/24/EC.

Article 2

The procedure for the granting of EC component type-approval in respect of the space for mounting the rear registration plate for a type of two or three-wheel motor vehicle and the conditions governing the free movement of such vehicles shall be as laid down in Chapters II and III of Directive 2002/24/EC.

Article 3

The amendments necessary to adapt to technical progress the requirements of Annex I shall be adopted in accordance with the procedure referred to in Article 18(2) of Directive 2002/24/EC.

Article 4

1 Member States shall not, on grounds relating to the space for mounting the rear registration plate:

- refuse, in respect of a type of two or three-wheel motor vehicle, to grant EC type-approval,
- prohibit the registration, sale or entry into service of two or three-wheel motor vehicles,

if the space for mounting the rear registration plate complies with the requirements of this Directive.

2 Member States shall refuse to grant EC type-approval for any type of two or three-wheel motor vehicle on grounds relating to the space for mounting the rear registration plate if the requirements of this Directive are not fulfilled.

3 Member States shall communicate to the Commission the text of the main provisions of national law which they adopt in the field covered by this Directive.

Article 5

Directive 93/94/EEC, as amended by the Directive listed in Annex II, Part A, is repealed, without prejudice to the obligations of the Member States relating to the time-limits for transposition into national law and application of the Directives set out in Annex II, Part B.

References to the repealed Directive shall be construed as references to this Directive and shall be read in accordance with the correlation table set out in Annex III.

Article 6

This Directive shall enter into force on the 20th day following its publication in the *Official Journal of the European Union*.

It shall apply from 1 January 2010.

Article 7

This Directive is addressed to the Member States.

Done at Brussels, 13 July 2009.

For the European Parliament

The President

H.-G. PÖTTERING

For the Council

The President

E. ERLANDSSON

ANNEX I

1. DIMENSIONS

The dimensions of the space for mounting the rear registration plate of two or three-wheel motor vehicles⁽⁶⁾ are as follows:

1.1. **Mopeds and light quadricycles without a body**

1.1.1. *Width:* 100 mm;

1.1.2. *Height:* 175 mm;

or

1.1.3. *Width:* 145 mm;

1.1.4. *Height:* 125 mm.

1.2. **Motorcycles, tricycles up to a maximum power of 15 kW and quadricycles, other than light quadricycles, without a body**

1.2.1. *Width:* 280 mm;

1.2.2. *Height:* 210 mm.

1.3. **Tricycles with a maximum power exceeding 15 kW, light quadricycles fitted with a body and quadricycles, other than light quadricycles, fitted with a body**

1.3.1. The provisions for passenger cars as set out in Council Directive 70/222/EEC⁽⁷⁾ shall apply.

2. GENERAL LOCATION

2.1. The mounting for the rear registration plate must be located at the rear of the vehicle in such a manner that:

2.1.1. the plate can be positioned within the longitudinal planes passing through the outer extremities of the vehicle.

3. INCLINATION

3.1. The rear registration plate:

3.1.1. must be at right angles to the median longitudinal plane of the vehicle;

3.1.2. may be inclined from the vertical by not more than 30°, with the vehicle unladen, when the backing plate for the registration number faces upwards;

3.1.3. may be inclined by not more than 15° from the vertical, with the vehicle unladen, when the backing plate for the registration number faces downwards.

4. MAXIMUM HEIGHT

4.1. No point on the space for mounting the registration plate may be more than 1,5 m above the ground when the vehicle is unladen.

5. MINIMUM HEIGHT

- 5.1. No point on the space for mounting the registration plate shall be less than 0,20 m above the ground or less than the radius of the wheel above the ground if that is less than 0,20 m, when the vehicle is unladen.

6. GEOMETRIC VISIBILITY

- 6.1. The space for mounting the plate must be visible within a space bordered by two dihedrals: one with a horizontal edge defined by two planes passing through the upper and lower horizontal edges of the space for mounting the plate, the angles of which in relation to the horizontal are shown in Figure 1; the other with a perceptibly vertical edge defined by two planes passing through each side of the plate, the angles of which in relation to the median longitudinal plane of the vehicle are shown in Figure 2.

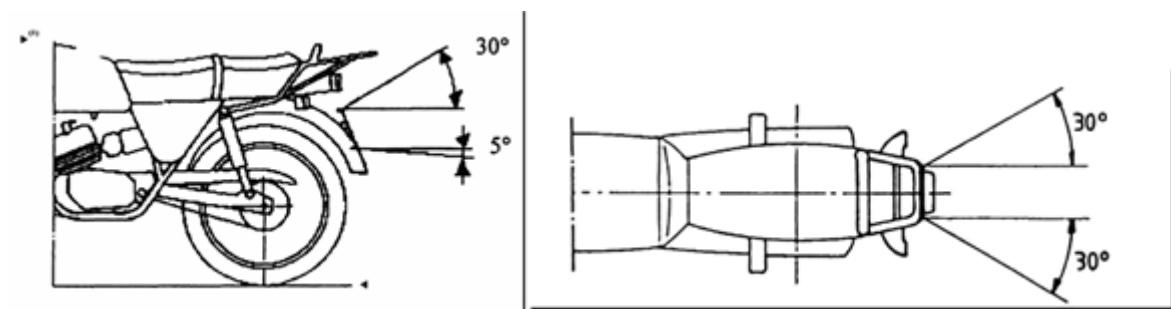

Appendix 1

Information to be attached to the application for EC component type-approval where this is submitted separately from the application for EC vehicle type-approval)
documents
in
respect
of the
space
for
mounting
the rear
registration
plate
of a
type of
two or
three-
wheel
motor
vehicle

Order No (assigned by the applicant):

The application for EC component type-approval in respect of the space for mounting the rear registration plate of a type of two or three-wheel motor vehicle must contain the information set out in Annex II to Directive 2002/24/EC, Part 1, section A, points:

- 0.1
- 0.2
- 0.4 to 0.6
- 2.2
- 2.2.1
- 9.6
- 9.6.1.

Appendix 2

**EC MODEL
component
type-
approval
certificate
in
respect
of the
space
for
mounting
the rear
registration
plate
of a
type of
two or
three-
wheel
motor
vehicle**

Report No ... by technical service ... date ...

EC component type-approval No ... Extension No ...

1. Trade mark or name of vehicle ...
2. Vehicle type ...
3. Manufacturer's name and address ...
- ...
4. Name and address of manufacturer's representative (if any) ...
- ...
5. Date vehicle submitted for test ...
6. EC component type-approval has been granted/refused⁽⁸⁾.
7. Place ...
8. Date ...
9. Signature ...

Status: This is the original version (as it was originally adopted).

ANNEX II

PART A

REPEALED DIRECTIVE WITH ITS AMENDMENT

(referred to in Article 5)

Council Directive 93/94/EEC	(OJ L 311, 14.12.1993, p. 83).
Commission Directive 1999/26/EC	(OJ L 118, 6.5.1999, p. 32).

PART B

LIST OF TIME-LIMITS FOR TRANSPOSITION
INTO NATIONAL LAW AND APPLICATION**(referred to in Article 5)**

Directive	Time-limit for transposition	Date of application
93/94/EEC	30 April 1995	1 November 1995 ^a
1999/26/EC	31 December 1999	1 January 2000 ^b
<p>a In conformity with Article 4 of Directive 93/94/EEC: From [1 May 1995], Member States may not, for reasons connected with the space for mounting the rear registration plate, prohibit the initial entry into service of vehicles which conform to this Directive.</p>		
<p>b In conformity with Article 2 of Directive 1999/26/EC:</p>		
<p>1. With effect from 1 January 2000, Member States shall not, on grounds relating to the space for mounting the rear registration plate:</p>		
<p>2. With effect from 1 July 2000, Member States shall refuse to grant EC type-approval for any type of two or three-wheel motor vehicle on grounds relating to the space for mounting the rear registration plate if the requirements of Directive 93/94/EEC, as amended by this Directive, are not fulfilled..</p>		

ANNEX III

CORRELATION TABLE

Directive 93/94/EEC	Directive 1999/26/EC	This Directive
Articles 1, 2 and 3		Articles 1, 2 and 3
	Article 2(1)	Article 4(1)
	Article 2(2)	Article 4(2)
Article 4(1)		—
Article 4(2)		Article 4(3)
—		Article 5

Status: This is the original version (as it was originally adopted).

—		Article 6
Article 5		Article 7
Annex		Annex I
—		Annex II
—		Annex III

Status: This is the original version (as it was originally adopted).

- (1) [OJ C 324, 30.12.2006, p. 11.](#)
- (2) Opinion of the European Parliament of 25 September 2007 ([OJ C 219 E, 28.8.2008, p. 66](#)) and Council Decision of 22 June 2009.
- (3) [OJ L 311, 14.12.1993, p. 83.](#)
- (4) See Annex II, Part A.
- (5) [OJ L 124, 9.5.2002, p. 1.](#)
- (6) In the case of mopeds, this is any registration and/or identification plate.
- (7) [OJ L 76, 6.4.1970, p. 25.](#)
- (8) Delete as appropriate.