

DIRECTIVE 2009/75/EC OF THE EUROPEAN PARLIAMENT AND OF THE COUNCIL
of 13 July 2009
on roll-over protection structures of wheeled agricultural or forestry tractors (static testing)
(codified version)
(Text with EEA relevance)

THE EUROPEAN PARLIAMENT AND THE COUNCIL OF THE EUROPEAN UNION,

Having regard to the Treaty establishing the European Community, and in particular Article 95 thereof,

Having regard to the proposal from the Commission,

Having regard to the opinion of the European Economic and Social Committee ⁽¹⁾,

Acting in accordance with the procedure laid down in Article 251 of the Treaty ⁽²⁾,

Whereas:

- (1) Council Directive 79/622/EEC of 25 June 1979 on the approximation of the laws of the Member States relating to the roll-over protection structures of wheeled agricultural or forestry tractors (static testing) ⁽³⁾ has been substantially amended several times ⁽⁴⁾. In the interests of clarity and rationality the said Directive should be codified.
- (2) Directive 79/622/EEC is one of the separate Directives of the EC type-approval system provided for in Council Directive 74/150/EEC of 4 March 1974 on the approximation of the laws of the Member States relating to the type-approval of wheeled agricultural or forestry tractors, as replaced by Directive 2003/37/EC of the European Parliament and of the Council of 26 May 2003 on type-approval of agricultural or forestry tractors, their trailers and interchangeable towed machinery, together with their systems, components and separate technical units ⁽⁵⁾, and lays down technical prescriptions concerning the design and construction of agricultural or forestry tractors, as regards their roll-over protection structure (static testing). Those technical prescriptions concern the approximation of the laws of the Member States, to enable the EC type-approval procedure provided for in Directive 2003/37/EC to be applied in respect of each type of tractor. Consequently, the provisions laid down in Directive 2003/37/EC relating to agricultural or forestry tractors, their trailers and interchangeable towed machinery, together with their

systems, components and separate technical units, apply to this Directive.

- (3) This Directive should be without prejudice to the obligations of the Member States relating to the time limits for transposition into national law of the Directives set out in Annex X, Part B,

HAVE ADOPTED THIS DIRECTIVE:

Article 1

This Directive shall apply to tractors as defined in Article 2(j) of Directive 2003/37/EC, having the following characteristics:

- (a) clearance beneath the rear axle of not more than 1 000 mm;
- (b) fixed or minimum adjustable track width of one of the driving axles of 1 150 mm or more;
- (c) possibility of being fitted with a multipoint coupling device for detachable tools and a draw bar;
- (d) mass of 800 kg or more, corresponding to the unladen mass of the tractor as referred to in point 2.1.1 of Annex I to Directive 2003/37/EC, including the roll-over protection structure fitted in compliance with this Directive and tyres of the largest size recommended by the manufacturer.

Article 2

1. Each Member State shall grant EC component type-approval for any type of roll-over protection structure and its tractor attachment which satisfies the construction and testing requirements laid down in Annexes I to V.

2. A Member State which has granted EC component type-approval shall take the measures required to verify, in so far as is necessary and if need be in cooperation with the competent authorities in the other Member States, that production models conform to the approved type. Such verification shall be limited to spot checks.

⁽¹⁾ OJ C 211, 19.8.2008, p. 17.

⁽²⁾ Opinion of the European Parliament of 17 June 2008 (not yet published in the Official Journal) and Council Decision of 22 June 2009.

⁽³⁾ OJ L 179, 17.7.1979, p. 1.

⁽⁴⁾ See Annex X, Part A.

⁽⁵⁾ OJ L 171, 9.7.2003, p. 1.

Article 3

Member States shall, for each type of roll-over protection structure and its tractor attachment which they approve pursuant to Article 2, issue to the manufacturer of the tractor or of the roll-over protection structure, or to their respective authorised representatives, an EC component type-approval mark conforming to the model shown in Annex VI.

Member States shall take all appropriate measures to prevent the use of marks liable to create confusion between roll-over protection structures which have been component type-approved pursuant to Article 2 and other devices.

Article 4

No Member State may prohibit the placing on the market of roll-over protection structures or their tractor attachments on grounds relating to their construction if they bear the EC component type-approval mark.

Nevertheless, a Member State may prohibit the placing on the market of roll-over protection structures bearing the EC component type-approval mark which consistently fail to conform to the approved type.

That Member State shall forthwith inform the other Member States and the Commission of the measures taken, specifying the reasons for its decision.

Article 5

The competent authorities of each Member State shall within one month send to the competent authorities of the other Member States copies of the component EC type-approval certificates, a model of which is shown in Annex VII, completed for each type of roll-over protection structure which they approve or refuse to approve.

Article 6

1. If the Member State which has granted EC component type-approval finds that a number of roll-over protection structures and their tractor attachments bearing the same EC component type-approval mark do not conform to the type which it has approved, it shall take the necessary measures to ensure that production models conform to the approved type.

The competent authorities of that Member State shall advise those of the other Member States of the measures taken which may, if necessary, where there is a serious and repeated failure to conform, extend to withdrawal of the EC component type-approval.

Those authorities shall take the same measures if they are informed by the competent authorities of another Member State of such failure to conform.

2. The competent authorities of the Member States shall within one month inform each other of any withdrawal of EC component type-approval and of the reasons for any such measure.

Article 7

Any decision taken pursuant to the provisions adopted in implementation of this Directive to refuse or withdraw component EC type-approval for roll-over protection structures and their tractor attachments, or to prohibit their placing on the market or their use, shall set out in detail the reasons on which it is based.

Such decision shall be notified to the party concerned, who shall at the same time be informed of the remedies available to him under the laws in force in the Member States and of the time limits allowed for the exercise of such remedies.

Article 8

1. No Member State may refuse to grant EC type-approval, to issue the document provided for in Article 2(u) of Directive 2003/37/EC, or to grant national type-approval in respect of a type of tractor on grounds relating to the roll-over protection structures, if these satisfy the requirements set out in Annexes I to IX.

2. Member States may not issue the document provided for in Article 2(u) of Directive 2003/37/EC in respect of a type of tractor which does not meet the requirements of this Directive.

Member States may refuse to grant national type-approval in respect of a type of tractor which does not meet the requirements of this Directive.

Article 9

No Member State may refuse to register or prohibit the sale, initial entry into service or use of any tractor on grounds relating to the roll-over protection structures if these satisfy the requirements set out in Annexes I to IX.

Article 10

For the purposes of EC type-approval, any tractor to which Article 1 refers must be fitted with a roll-over protection structure which satisfies the requirements laid down in Annexes I to IV.

However, the tractors defined in Article 1 of Directive 2009/57/EC of 13 July 2009 of the European Parliament and of the Council on roll-over protection structures of wheeled agricultural or forestry tractors⁽¹⁾ may, for the purposes of EC type-approval, be fitted with a roll-over protection structure which satisfies the requirements laid down in Annexes I to IV of that Directive.

⁽¹⁾ See page 1 of this Official Journal.

Article 11

Any amendments necessary to adapt to technical progress the requirements of Annexes I to IX shall be adopted in accordance with the procedure referred to in Article 20(3) of Directive 2003/37/EC.

Article 12

Member States shall communicate to the Commission the text of the main provisions of national law which they adopt in the field covered by this Directive.

Article 13

Directive 79/622/EEC, as amended by the acts listed in Annex X, Part A, is repealed, without prejudice to the obligations of the Member States relating to the time limits for transposition into national law of the Directives set out in Annex X, Part B.

References to the repealed Directive shall be construed as references to this Directive and shall be read in accordance with the correlation table in Annex XI.

Article 14

This Directive shall enter into force on the 20th day following its publication in the *Official Journal of the European Union*.

It shall apply from 1 January 2010.

Article 15

This Directive is addressed to the Member States.

Done at Brussels, 13 July 2009.

For the European Parliament

The President

H.-G. PÖTTERING

For the Council

The President

E. ERLANDSSON

LIST OF ANNEXES

ANNEX I	Conditions for EC component type-approval
ANNEX II	Conditions for testing the strength of the protection structures and of their attachment to tractors
ANNEX III	Test procedures
ANNEX IV	Figures
ANNEX V	Test report model relating to the EC component type-approval test of a protection structure (safety frame or cab) with regard to its strength as well as the strength of its attachment to the tractor (static testing)
ANNEX VI	Marks
ANNEX VII	Model of EC component type-approval certificate
ANNEX VIII	Conditions for EC type-approval
ANNEX IX	Annex to the EC type-approval certificate for a tractor type with regard to the strength of the protection structures (safety cab or frame) and of their attachment to the tractor (static testing)
ANNEX X	Part A: Repealed Directive with list of its successive amendments Part B: List of time limits for transposition into national law
ANNEX XI	Correlation table

ANNEX I

Conditions for EC component type-approval

1. DEFINITION

- 1.1. 'Roll-over protection structure' (safety cab or frame), hereinafter called 'protection structure', means the structure on a tractor the essential purpose of which is to avoid or limit risks to the driver resulting from roll-over of the tractor during normal use.
- 1.2. The structures mentioned in point 1.1 are characterised by the fact that during the tests prescribed in Annexes II and III they ensure an unobstructed space inside them large enough to protect the driver.

2. GENERAL REQUIREMENTS

- 2.1. Every protection structure and its attachment to a tractor must be so designed and constructed as to fulfil the essential purpose laid down in point 1.
- 2.2. This condition is considered to be fulfilled if the requirements of Annexes II and III are complied with.

3. APPLICATION FOR EC COMPONENT TYPE-APPROVAL

- 3.1. The application for EC component type-approval with regard to the strength of a protection structure and the strength of its attachment to a tractor shall be submitted by the tractor manufacturer or by the manufacturer of the protection structure or by their respective authorised representatives.
- 3.2. The application for EC component type-approval shall be accompanied by the undermentioned documents in triplicate and by the following particulars:
 - general arrangement drawing either to a scale marked on the drawing or giving the main dimensions of the protection structure. This drawing must in particular show details of the mounting components,
 - photographs from side and rear showing mounting details,
 - brief description of the protection structure including type of construction, details of mounting on the tractor and, where necessary, details of cladding, means of access and escape, details of interior padding and features to prevent continuous rolling and details of heating and ventilation,
 - details of materials used in structural parts including attaching brackets and fixing bolts (see Annex V).
- 3.3. A tractor representative of the tractor type for which the protection structure to be approved is intended shall be submitted to the technical service responsible for conducting the component type-approval tests. This tractor shall be fitted with the protection structure.
- 3.4. The holder of EC component type-approval may request its extension to other tractor types. The competent authority which has granted the original EC component type-approval shall grant the extension if the approved protection structure and the type(s) of tractor for which the extension is requested comply with the following conditions:
 - the mass of the unballasted tractor, as defined in point 1.3 of Annex II, does not exceed by more than 5 % the reference mass used in the test,
 - the method of attachment and the tractor's components to which the attachments are made are identical,
 - any components such as mudguards and bonnet cowls which may provide support for the protection structure are identical,
 - the position and critical dimensions of the seat in the protection structure and the relative positions of the protection structure and the tractor shall be such that the zone of clearance would have remained within the protection of the deflected structure throughout all tests.

4. MARKINGS

4.1. Every protection structure conforming to the approved type shall bear the following markings:

4.1.1. the trade mark or name;

4.1.2. a component type-approval mark conforming to the model in Annex VI;

4.1.3. serial number of the protection structure;

4.1.4. make and type(s) of tractor(s) for which the protection structure is intended.

4.2. All these particulars must appear on a small plate.

4.3. These markings must be visible, legible and indelible.

ANNEX II

Conditions for testing the strength of the protection structures and of their attachment to tractors

1. GENERAL REQUIREMENTS

1.1. Test purposes

Tests made using special rigs are intended to simulate such loads as are imposed on a protection structure, when the tractor overturns. These tests, described in Annex III, enable observations to be made on the strength of the protection structure and any brackets attaching it to the tractor and any parts of the tractor which transmit the test force.

1.2. Preparation for test

1.2.1. The protection structure must conform to the series production specifications. It shall be attached in accordance with the manufacturer's declared method of attachment to one of the tractors for which it is designed. A complete tractor is not required for the test; however, the protection structure and parts of the tractor on which it is attached for the tests shall represent an operating installation, hereinafter referred to as 'the assembly'.

1.2.2. The assembly shall be secured to the bedplate so that the members connecting the assembly and the bedplate do not deflect significantly in relation to the protection structure under loading. The method of attachment of the assembly to the bedplate must not of itself modify the strength of the assembly.

1.2.3. The assembly must be supported and secured or modified so that all the test energy is absorbed by the protection structure and its attachment to the rigid components of the tractor.

1.2.3.1. To comply with the requirements of point 1.2.3, the modification shall lock any tractor ride suspension system so as to ensure that it does not absorb any of the test energy.

1.2.4. For the tests the tractor must be fitted with all structural components of the series production which may influence the strength of the protection structure or which may be necessary for the strength test.

Components which may create a hazard in the zone of clearance must also be fitted so that they may be examined to see whether the requirements of point 4 have been fulfilled.

All components that the driver could himself remove shall be removed for the tests. If it is possible to keep the doors and windows open or to remove them when the tractor is in use, they must be kept open or removed during the tests, so as not to increase the strength of the roll-over protection structure. If, in this position, they constitute a danger for the driver should the tractor roll over, the test report must refer to this fact.

1.3. Tractor mass

The reference mass m_0 , used in the formulae (see Annex III) to calculate the energies and the crushing force, shall be at least that defined in point 2.1.1 of Annex I to Directive 2003/37/EC (i.e. excluding optional accessories but including coolant, oils, fuel, tools and driver) plus the protection structure and less 75 kg.

Not included are optional front or rear weights, tyre ballast, mounted implements, mounted equipment or any specialised components.

2. APPARATUS AND EQUIPMENT

2.1. Horizontal loading tests (side and longitudinal)

2.1.1. Material, equipment and tie-down means adequate to ensure that the assembly is firmly fixed to the bedplate, independently of tyres if present.

2.1.2. Means of applying a horizontal force on the protection structure by a stiff beam as shown in figures 1 and 2 of Annex IV.

2.1.2.1. The stiff beam shall have a vertical face dimension of 150 mm.

2.1.2.2. Provision must be made so that the load can be uniformly distributed normal to the direction of loading and along a beam having a length of one of the exact multiples of 50 between 250 and 700 mm.

- 2.1.2.3. The edges of the beam in contact with the protection structure shall be curved with a maximum radius of 50 mm.
- 2.1.2.4. Universal joints — or the equivalent — shall be incorporated to ensure that the loading device does not constrain the structure in rotation or translation in any direction other than the direction of loading.
- 2.1.2.5. Where the horizontal length of the protection structure to which the load is to be applied does not constitute a straight line normal to the direction of application of the load, the space shall be packed so as to distribute the load over this length.
- 2.1.3. Equipment for measuring as far as is technically possible the energy absorbed by the protection structure and the rigid parts of the tractor to which it is attached, for example by measuring the force applied along its direction of application and the corresponding deflection relative to a point on the tractor chassis.
- 2.1.4. Means for proving that the zone of clearance has not been entered during the test. A rig according to figures 6a, 6b and 6c of Annex IV can be used.
- 2.2. Crushing tests (rear and front)
- 2.2.1. Material, equipment and tie-down means adequate to ensure that the tractor is firmly fixed to the bedplate, independently of tyres.
- 2.2.2. Means for applying a vertical force on the protection structure, such as shown in figure 3 of Annex IV, including a stiff crushing beam with a width of 250 mm.
- 2.2.3. Equipment for measuring the total vertical force applied.
- 2.2.4. Means for proving that the zone of clearance has not been entered during the test. A rig according to figures 6a, 6b and 6c of Annex IV can be used.
- 2.3. Measurement tolerances
- 2.3.1. Dimensions: ± 3 mm.
- 2.3.2. Deflection: ± 3 mm.
- 2.3.3. Tractor mass: ± 20 kg.
- 2.3.4. Loads and forces: ± 2 %.
- 2.3.5. Direction of loading: deviation from horizontal and vertical directions specified in Annex III:
- at start of test, under zero load: $\pm 2^\circ$,
 - during test, under load: 10° above and 20° below the horizontal. These variations shall as far as possible be kept to a minimum.
3. TESTS
- 3.1. General requirements
- 3.1.1. Sequence of tests
- 3.1.1.1. The sequence of tests shall be as follows:
- 3.1.1.1.1. Longitudinal loading (Annex III, point 1.2)

For tractors with at least 50 % of the mass as defined in point 1.3 on the rear wheels the longitudinal loading shall be applied from the rear (case 1). For other tractors the longitudinal loading shall be applied from the front (case 2).

3.1.1.1.2. First crushing test

The first crushing test shall be applied at the same end of the protection structure as the longitudinal loading, i.e.:

- at the rear in case 1 (Annex III, point 1.5), or
- at the front in case 2 (Annex III, point 1.6).

3.1.1.1.3. Loading from the side (Annex III, point 1.3)

3.1.1.1.4. Second crushing test

The second crushing test shall be applied at the opposite end of the protection structure to the longitudinal loading, i.e.:

- at the front in case 1 (Annex III, point 1.6), or
- at the rear in case 2 (Annex III, point 1.5).

3.1.1.1.5. Second longitudinal loading (Annex III, point 1.7)

A second longitudinal loading shall be applied to tractors fitted with a protection structure designed to be tilted when the direction of application of the longitudinal loading (see point 3.1.1.1.1) would not have tilted the protection structure.

3.1.1.2. If, during the test, any part of the restraining equipment breaks or moves, the test shall be re-started.

3.1.1.3. No repairs or adjustments to the tractor or protection structure may be carried out during the tests.

3.1.2. Wheel track width

The wheels shall be removed or set at a track width setting which ensures that no interference can occur with the protection structure during the tests.

3.1.3. Removal of non-hazard creating components

All components of the tractor and protection structure which, as complete units, constitute protection for the driver — including weather protection — shall be supplied complete on a tractor for inspection.

The protection structure to be tested need not be fitted with front, side or rear windows of safety glass or similar material, or with any detachable panels, fittings and accessories, which have no function of structural strength and which cannot create a hazard in the event of overturning.

3.1.4. Instrumentation

The protection structure shall be instrumented with the necessary equipment to obtain the data required to draw the force-deflection diagram (see figure 4 of Annex IV). Total and permanent protection structure deflection shall be measured and noted for each stage of the test (see figure 5 of Annex IV).

3.1.5. Direction of loading

In the case of a tractor whose seat is not on the median plane of the tractor and/or non-symmetrical strength of the structure, the side loading shall be on the side most likely to lead to infringement of the zone of clearance during the tests (see also Annex III, point 1.3).

4. ACCEPTANCE CONDITIONS

4.1. A protection structure submitted for EC component type-approval shall be considered as having satisfied the strength requirements if after the tests it fulfils the following conditions:

4.1.1. No part of the zone of clearance as described in point 3.2 of Annex III has been entered by, or has been outside the protection of, the protection structure during the tests specified in points 1.2, 1.3, 1.5, 1.6 and, where appropriate, point 1.7 of Annex III.

If an overload test has been carried out, the force applied when the specified energy is absorbed shall be greater than 0,8 of the maximum force occurring during both the main test and the overload test concerned (see figures 4b and 4c of Annex IV).

- 4.1.2. During the tests the protection structure must not impose any constraint on the seat structure.
- 4.1.3. At the point when the required energy level is attained in each of the specified horizontal loading tests, the force shall exceed $0,8 F_{\max}$.
- 4.2. In addition there shall be no other feature presenting a particular hazard to the driver, for example insufficient padding inside the roof or anywhere else where the driver's head may strike.
5. TEST REPORT
- 5.1. The test report shall be attached to the EC component type-approval certificate referred to in Annex VII. The presentation of the report shall be as shown in Annex V. It shall include:
- 5.1.1. A general description of the protection structure's shape and construction (see Annex V for the obligatory dimensions), including the provisions for normal entry, exit and escape; the provisions for the heating and ventilation system, and other accessories where these are available and where they could affect the zone of clearance or might create a hazard.
- 5.1.2. Details of any special features such as devices to prevent the continuous rolling of the tractor.
- 5.1.3. A brief description of any interior padding.
- 5.1.4. A statement of the type of windscreen and glazing fitted and of any EC or other approval marking incorporated.
- 5.2. If EC component type-approval is being extended for other tractor types, the report must include the exact reference of the report of the original EC component type-approval as well as precise indications regarding the requirements laid down in point 3.4 of Annex I.
- 5.3. The report must identify clearly the tractor type (make, type and commercial description, etc.) used for testing and the types for which the protection structure is intended.
6. SYMBOLS
- m_t = reference tractor mass (kg), as defined in point 1.3.
- D = deflection (mm) of structure at the point of and in line with the load application.
- D' = deflection (mm) of structure for the calculated energy required.
- F = static load force (N) (newtons).
- F_{\max} = maximum static load force occurring during loading, (N) with the exception of the overload.
- F = force for the calculated energy required.
- F-D = force/deflection curve.
- E_{is} = energy input to be absorbed during side loading (J) (joules).
- $E_{il\ 1}$ = energy input to be absorbed during longitudinal loading (J).
- $E_{il\ 2}$ = energy input to be absorbed during application of the second longitudinal load (J).
- F_r = applied force at rear in the crushing test (N).
- F_f = applied force at front in the crushing test (N).
-

ANNEX III

TEST PROCEDURE

1. HORIZONTAL LOADING AND CRUSHING TESTS

1.1. General provisions for horizontal loading tests

1.1.1. The loads applied to the protection structure shall be distributed by means of a stiff beam, complying with the specifications laid down in point 2.1.2 of Annex II, located normal to the direction of load application; the stiff beam may be equipped with a means of preventing its being displaced sideways. The rate of deflection under loading shall not be greater than 5 mm/s. As the load is applied, the values F and D shall be recorded simultaneously at deflection increments of 15 mm or less, to ensure accuracy. Once the initial application has commenced, the load shall not be reduced until the test has been completed; but it is permitted to cease increasing the load if desired, for example to record measurements.

1.1.2. If the structural member to which the load is to be applied is curved, the specifications laid down in point 2.1.2.5 of Annex II must be complied with. The application of a load must, however, comply with the requirements of point 1.1.1 above and point 2.1.2 of Annex II.

1.1.3. If no structural cross member exists at the point of application, a substitute test beam which does not add strength to the structure may be utilised for the test procedure.

1.1.4. The structure shall be inspected visually when the load is removed after each loading test has been completed. If cracks or tears have occurred during loading, the overload test specified in point 1.4 below shall be carried out before proceeding to the next loading in the sequence given in point 3.1.1.1 of Annex II.

1.2. Longitudinal loading (see figure 2 of Annex IV)

Load application shall be horizontal and parallel to the vertical median plane of the tractor.

For tractors with at least 50 % of their mass, as defined in point 1.3 of Annex II, on the rear wheels, the longitudinal rear load and the lateral load shall be applied on different sides of the median longitudinal plane of the protection structure. For tractors with at least 50 % of their mass on the front wheels, the longitudinal front load shall be on the same side of the median longitudinal plane of the protection structure as the lateral load.

It shall be applied to the uppermost transverse structural member of the protection structure (i.e. the part which would be likely to strike the ground first in an overturning incident).

The point of application of the load shall be located one-sixth of the width of the top of the protection structure inwards from the outside corner. The width of the protection structure shall be taken as the distance between two lines parallel to the vertical median plane of the tractor touching the outside extremities of the protection structure in the horizontal plane touching the top of the uppermost transverse structural members.

The length of the beam shall be not less than one-third of the width of the protection structure (as previously described) and not more than 49 mm greater than this minimum.

The longitudinal loading is applied from the rear or front, as defined in point 3.1.1.1 of Annex II.

The test shall be stopped whenever:

(a) the strain energy absorbed by the protection structure is equal to or greater than the required energy input $E_{il 1}$ (where $E_{il 1} = 1,4 m_1$);

(b) the structure infringes the zone of clearance or leaves the zone of clearance unprotected.

1.3. Loading from the side (see figure 1 of Annex IV)

The loading shall be applied horizontally at 90° to the vertical median plane of the tractor. It shall be applied to the upper extremity of the protection structure at a point 300 mm forward of the seat reference point with the seat in its rearmost position (see point 2.3.1). If the protection structure has any projection on the side which would be certain to contact the ground first during a sideways overturn, the loading shall be applied at that point. In the case of a tractor with a reversible position, the load shall be applied to the upper extremity of the roll-over protection structure half-way between the two seat reference points.

The beam shall be as long as practicable, but no more than 700 mm in length.

The test shall be stopped whenever:

- (a) the strain energy absorbed by the protection structure is equal to or greater than the required energy input E_{is} (where $E_{is} = 1,75 m_t$); or
- (b) the structure infringes the zone of clearance or leaves the zone of clearance unprotected.

1.4. Overload test (see figures 4a, 4b and 4c in Annex IV)

1.4.1. The overload test must be carried out if the force decreases by more than 3 % during the last 5 % of the deflection achieved, where the energy required is absorbed by the structure (see figure 4b).

1.4.2. The overload test involves the gradual increase of the horizontal load by increments of 5 % of the initial energy requirement up to a maximum of 20 % of energy added (see figure 4c).

1.4.2.1. The overload test is satisfactory if, after each increase by 5 %, 10 % or 15 % in the energy required, the force decreases by less than 3 % for a 5 % increment and remains more than $0,8 F_{max}$.

1.4.2.2. The overload test is satisfactory if, after the structure has absorbed 20 % of the added energy, the force exceeds $0,8 F_{max}$.

1.4.2.3. Additional cracks or tears and/or entry into or lack of protection of the zone of clearance due to elastic deformation are permitted during the overload test. However, after the removal of the load, the structure shall not enter the zone of clearance, which shall be completely protected.

1.5. Crushing at the rear

The beam shall be positioned over the rear uppermost structural members and the resultant of crushing forces shall be located in the vertical longitudinal reference plane. A force $F_r = 20 m_t$ shall be applied.

Where the rear part of the protection structure roof will not sustain the full crushing force, the force shall be applied until the roof is deflected to coincide with the plane joining the upper part of the protection structure with that part of the rear of the tractor capable of supporting the vehicle's mass when overturned. The force shall then be removed, and the tractor or loading force repositioned so that the beam is over that point of the protection structure which would then support the tractor when completely overturned. The force F_r shall then be applied.

The force F_r shall be applied for a minimum of five seconds following the cessation of the visually detectable deflection.

The test shall be stopped if the structure infringes the zone of clearance or leaves the zone of clearance unprotected.

1.6. Crushing at the front

The beam shall be positioned across the front uppermost structural members and the resultant of crushing forces shall be located in the vertical longitudinal reference plane. A force $F_f = 20 m_t$ shall be applied.

Where the front part of the protection structure roof will not sustain the full crushing force, the force shall be applied until the roof is deflected to coincide with the plane joining the upper part of the protection structure with that part of the front of the tractor capable of supporting the vehicle's mass when overturned. The force shall then be removed, and the tractor or loading force repositioned so that the beam is over that point of the protection structure which would then support the tractor when completely overturned. The force F_f shall then be applied.

The force F_f shall be applied for a minimum of five seconds following the cessation of the visually detectable deflection.

The test shall be stopped if the structure infringes the zone of clearance or leaves the zone of clearance unprotected.

1.7. Second longitudinal loading

Load application shall be horizontal parallel to the vertical median plane of the tractor.

The second longitudinal loading is applied from the rear or front as defined in point 3.1.1.1 of Annex II.

It shall be applied in the opposite direction to and at the corner furthest from the longitudinal loading in point 1.2.

It shall be applied to the uppermost transverse structural member of the protection structure (i.e. that part which would be likely to strike the ground in an overturning incident).

The point of application of the load shall be located one sixth of the width of the top of the protection structure inwards from the outside corner. The width of the protection structure shall be taken as the distance between two lines parallel to the vertical median plane of the tractor touching the outside extremities of the protection structure in the horizontal plane touching the top of the uppermost transverse structural members.

The length of the beam shall be not less than one third of the width of the protection structure (as previously described) and not more than 49 mm more than this minimum.

The test shall be stopped whenever:

- (a) the strain energy absorbed by the structure is equal to or greater than the required energy input $E_{il\ 2}$ (where $E_{il\ 2} = 0,35 m_1$); or
- (b) the structure infringes the zone of clearance or leaves the zone of clearance unprotected.

2. ZONE OF CLEARANCE

- 2.1. The zone of clearance is illustrated in figure 6 of Annex IV and is defined in relation to a vertical reference plane generally longitudinal to the tractor and passing through a seat reference point, described in point 2.3, and the centre of the steering wheel. The reference plane shall be assumed to move horizontally with the seat and steering wheel during application of the load but to remain perpendicular to the floor of the tractor or of the protection structure if this is resiliently mounted.

Where the steering wheel is adjustable, its position shall be that for normal seated driving.

- 2.2. The boundaries of the zone shall be taken as:

- 2.2.1. vertical planes 250 mm on either side of the reference plane extending upwards from the seat reference point for 300 mm;
- 2.2.2. parallel planes extending from the upper edge of the planes referred to in point 2.2.1 to a maximum height of 900 mm above the seat reference point and inclined in such a way that the upper edge of the plane on the side from which the side loading is applied is at least 100 mm from the reference plane;
- 2.2.3. a horizontal plane 900 mm above the seat reference point;
- 2.2.4. an inclined plane perpendicular to the reference plane and including a point 900 mm directly above the seat reference point and the rearmost point of the seat backrest;
- 2.2.5. a surface, if necessary curved, with a series of straight lines perpendicular to the reference plane extending downwards from the rearmost point of the seat in contact with the seat backrest throughout its length;
- 2.2.6. a curvilinear surface, perpendicular to the reference plane, with a radius of 120 mm tangential to planes referred to in points 2.2.3 and 2.2.4;
- 2.2.7. a curvilinear surface, perpendicular to the reference plane, having a radius of 900 mm extending forward for 400 mm from and tangential to the plane referred to in point 2.2.3 at a point 150 mm forward of the seat reference point;
- 2.2.8. an inclined plane perpendicular to the reference plane, joining surface referred to in point 2.2.7 at its forward edge and passing 40 mm from the steering wheel. In the case of a high steering wheel position this plane is replaced by a tangent plane to the surface referred to in point 2.2.7;
- 2.2.9. a vertical plane, perpendicular to the reference plane, 40 mm forward of the steering wheel;
- 2.2.10. a horizontal plane through the seat reference point;
- 2.2.11. in the case of a tractor with a reversible driving position, the clearance shall be a combination of the two clearances determined for the two positions of the steering wheel and seat;

2.2.12. in the case of a tractor which can be fitted with optional seats, the tests shall be based on the combined seat-reference-point clearance for all available seat options. The roll-over protection structure must not enter the combined clearance around the various seat reference points;

2.2.13. where a new seat option is proposed after the test has taken place, a calculation shall be made to determine whether the clearance around the new seat reference point is located entirely within the clearance previously established. If this is not the case, a new test shall be required.

2.3. Seat location and seat reference point

2.3.1. For the purpose of defining the zone of clearance in point 2.1 the seat shall be at the rearmost point of any horizontal adjustment range. It shall be set at the highest point of the vertical adjustment range where this is independent of adjustment of its horizontal position.

The reference point shall be established using the apparatus illustrated in figures 7 and 8 of Annex IV to simulate loading by a human occupant. The apparatus shall consist of a seat pan board and backrest boards. The lower backrest board shall be jointed in the region of the ischium humps (A) and loin (B), the joint (B) being adjustable in height.

2.3.2. The reference point is defined as the point in the median longitudinal plane of the seat where the tangential plane of the lower backrest and a horizontal plane intersect. This horizontal plane cuts the lower surface of the seat pan board 150 mm in front of the abovementioned tangent.

2.3.3. Where a seat incorporates a free sprung suspension travel, whether or not this can be adjusted for the weight of the driver, the seat shall be set at the mid-point of this travel.

The apparatus shall be positioned on the seat. It shall then be loaded with a force of 550 N at a point 50 mm in front of joint (A), and the two parts of the backrest board shall be lightly pressed tangentially against the backrest.

2.3.4. If it is not possible to determine definite tangents to each area of the backrest (below and above lumbar region) the following shall be done:

2.3.4.1. where no definite tangent to the lower area is possible, the lower part of the backrest board is pressed against the backrest vertically;

2.3.4.2. where no definite tangent to the upper area is possible, the joint (B) is fixed at a height which is 230 mm above the seat reference point, if the lower part of the backrest board is vertical. Then the two parts of the backrest board are lightly pressed against the backrest.

3. CONTROLS AND MEASUREMENTS TO BE MADE

3.1. Zone of clearance

During each test the protection structure shall be examined to see whether any part of the protection structure has entered a zone of clearance round the driving seat as defined in point 2.1. In addition, the protection structure shall be examined to determine whether any part of the zone of clearance is outside the protection of the protection structure. For this purpose, it shall be considered to be outside the protection of the protection structure if any part of it would have come into contact with flat ground if the tractor had overturned towards the direction from which the loading was applied. For this purpose, the tyre and track setting shall be assumed to be the smallest specified by the manufacturer.

3.2. Final permanent deflection

After the tests, the final permanent deflection of the protection structure shall be recorded. For this purpose, before the start of the test, the position of the main protection structure members in relation to the seat reference point shall be recorded.

ANNEX IV

FIGURES

- Figure 1:* Point of application of lateral load
- Figure 2:* Point of application of longitudinal rear load
- Figure 3:* Example of an arrangement for crushing test
- Figure 4a:* Force/deflection curve — overload test not necessary
- Figure 4b:* Force/deflection curve — overload test necessary
- Figure 4c:* Force/deflection curve — overload test to be continued
- Figure 5:* Illustration of the terms 'permanent deflection', 'elastic deflection' and 'total deflection'
- Figure 6a:* Side view of zone of clearance
- Figure 6b:* Front/rear view of zone of clearance
- Figure 6c:* Isometric view
- Figure 7:* Apparatus for determination of seat reference point
- Figure 8:* Method of determining seat reference point

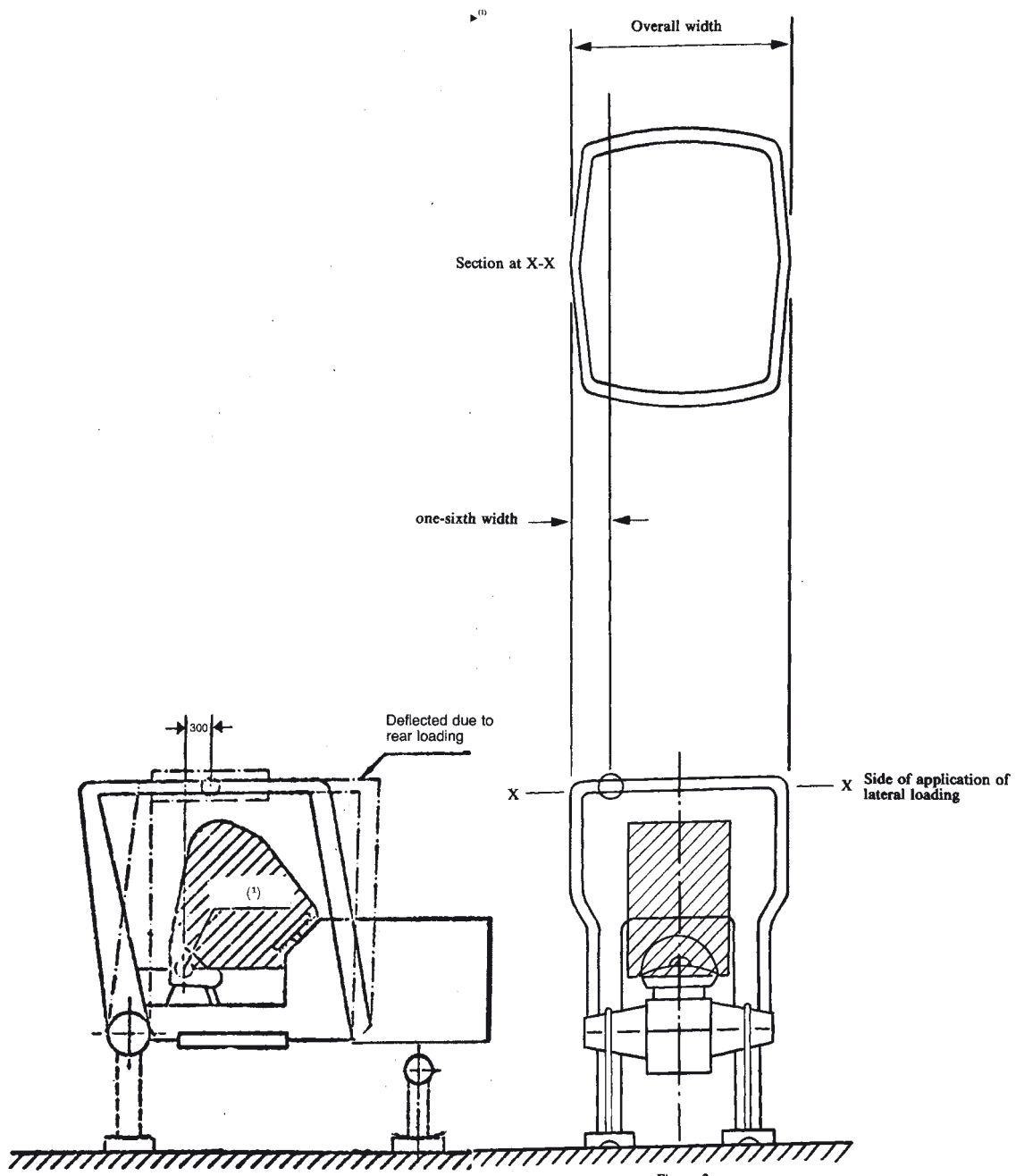

Figure 1

Figure 2

►⁽¹⁾ Point of application of lateral loading ◀

Point of application of rear longitudinal loading (when at least 50 % of the tractor mass rests on the rear wheels) ◀

(1) Seat reference point.

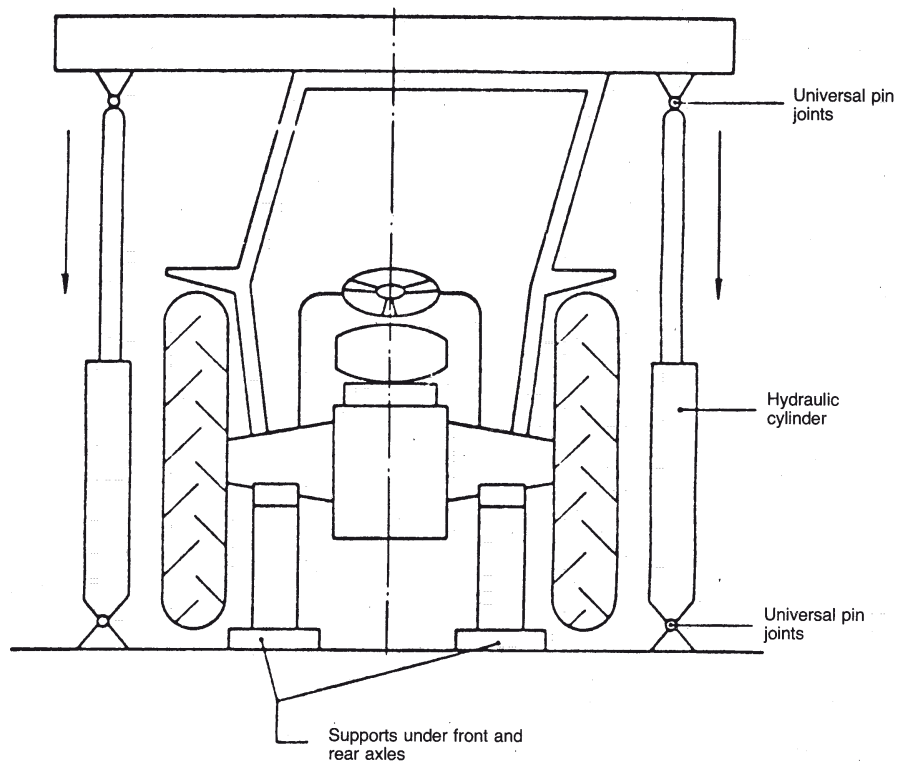
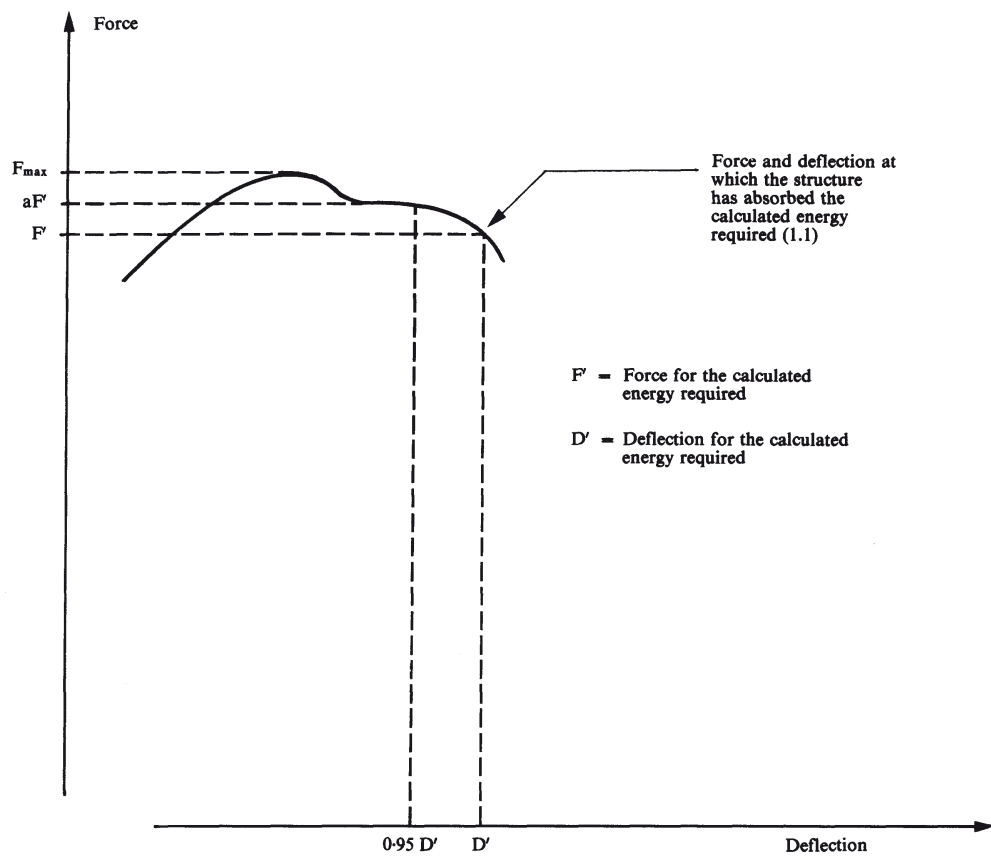

Figure 3

Example of an arrangement for crushing test



1. Point of reference $aF' = 0,95 D'$
- 1.1. The overload test is not necessary since $aF' < 1,03 F'$

Figure 4a

Force/deflection curve — overload test not necessary

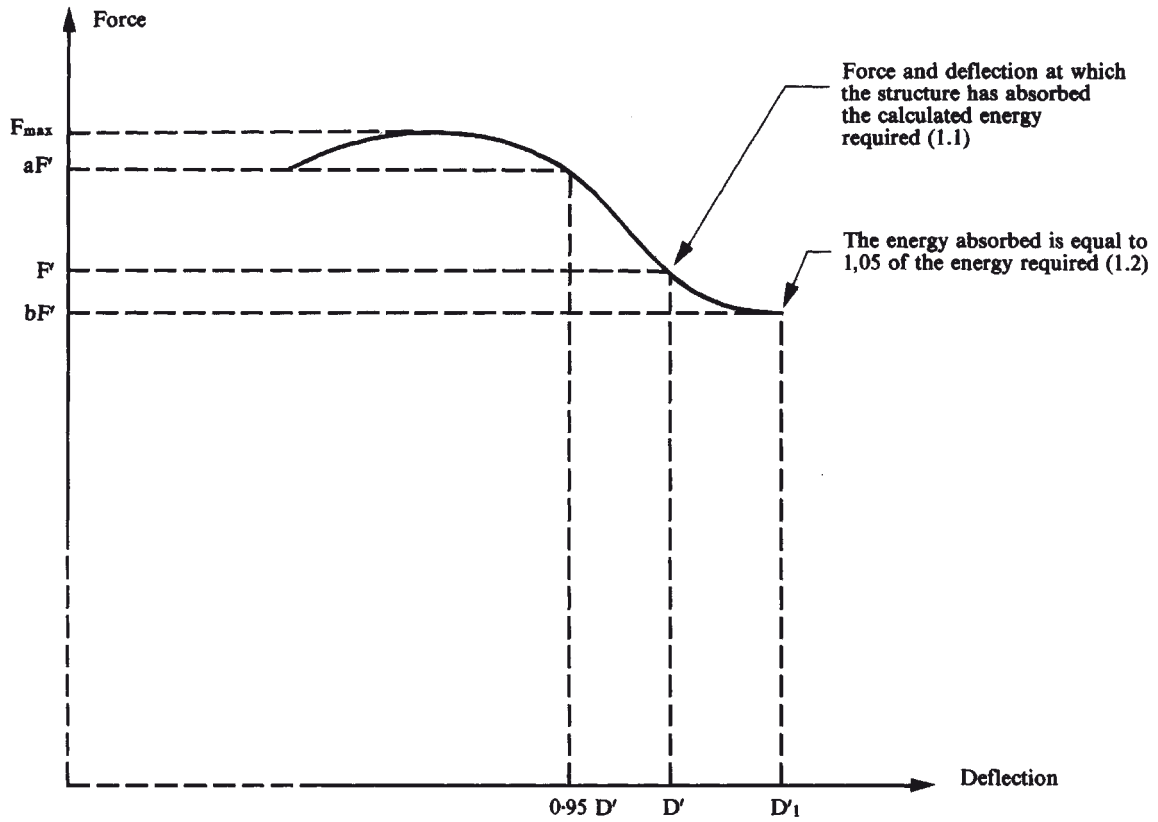

1. Reference point $aF' = 0,95 D'$
- 1.1. The overload test is necessary since $aF' > 1,03 F'$
- 1.2. The overload test is satisfactory since $bF' > 0,97 F'$ and $bF' > 0,8 F_{max}$

Figure 4b

Force/deflection curve — overload test necessary

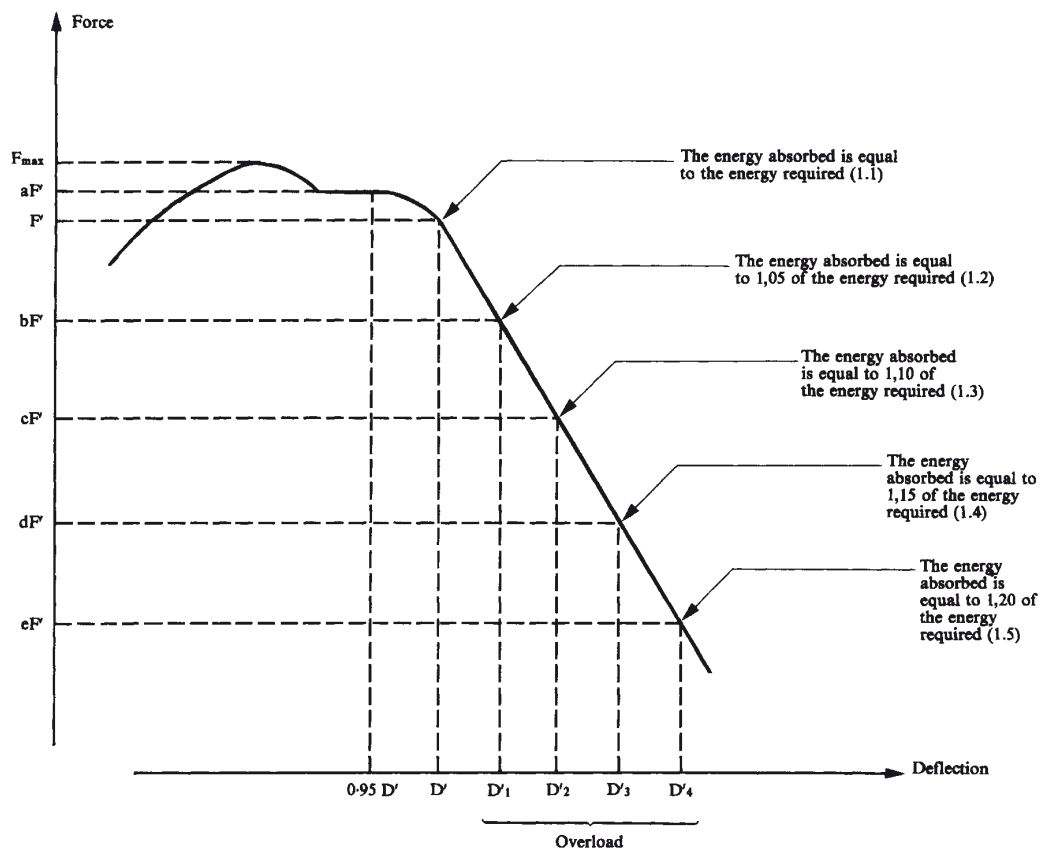

1. Reference point $aF' = 0,95 D'$
 - 1.1. The overload test is necessary since $aF' > 1,03 F'$
 - 1.2. If bF' is less than $0,97 F'$, the overload test must be carried out
 - 1.3. Since $cF' < 0,97 bF'$ the overload test must be continued
 - 1.4. Since $dF' < 0,97 cF'$ the overload test must be continued
 - 1.5. The overload test is satisfactory since $eF' > 0,8 F_{max}$
- NB: If at any time F drops below $0,8 F_{max}$, the structure shall be rejected.

Figure 4c

Force/deflection curve — overload test to be continued

1. Permanent deflection
2. Elastic deflection
3. Total (permanent plus elastic) deflection

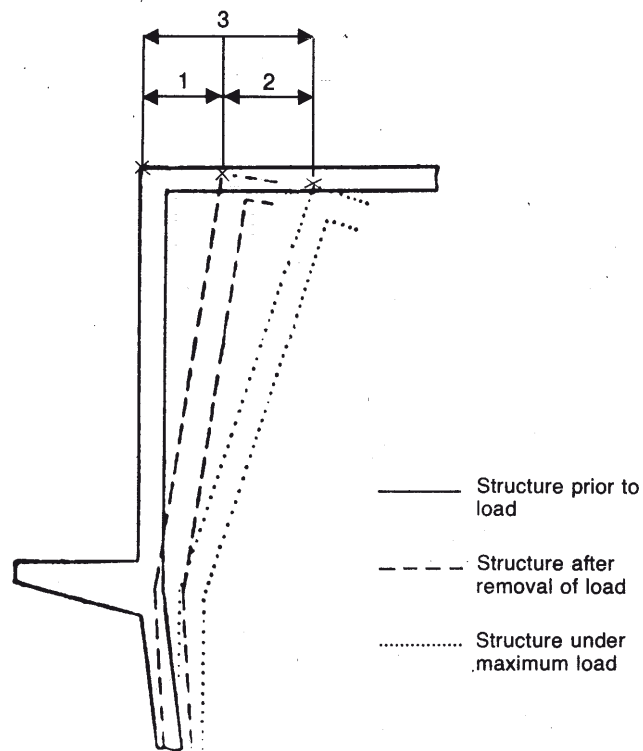

Figure 5

Illustration of the terms permanent, elastic and total deflection

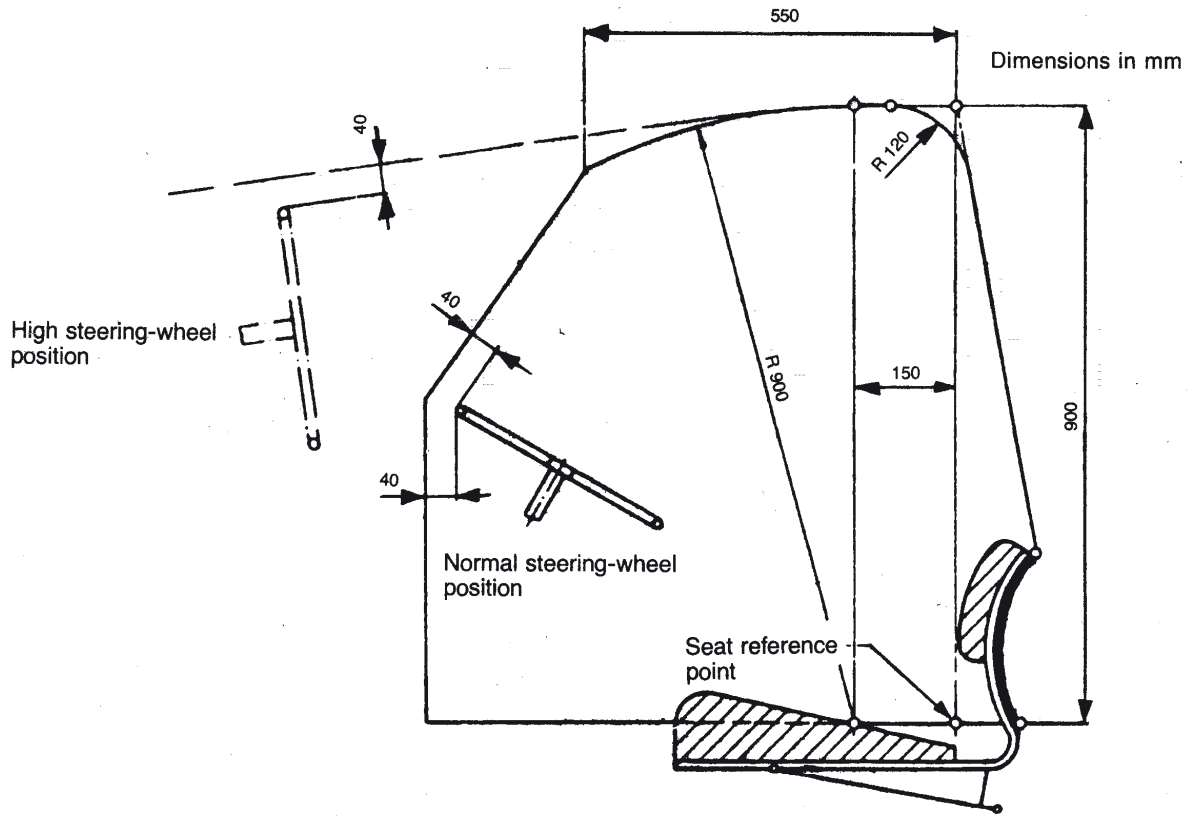

Figure 6a

Side view of zone clearance

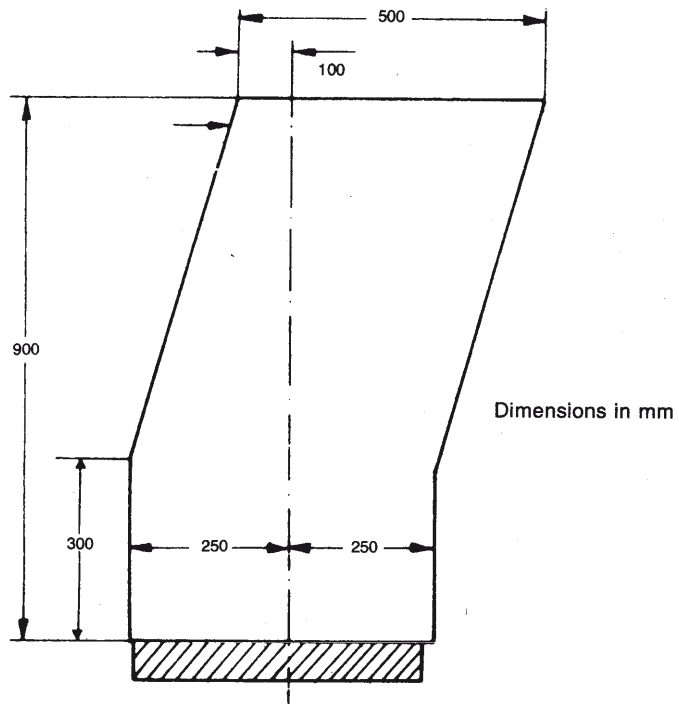

Figure 6b

Front/rear view of zone of clearance

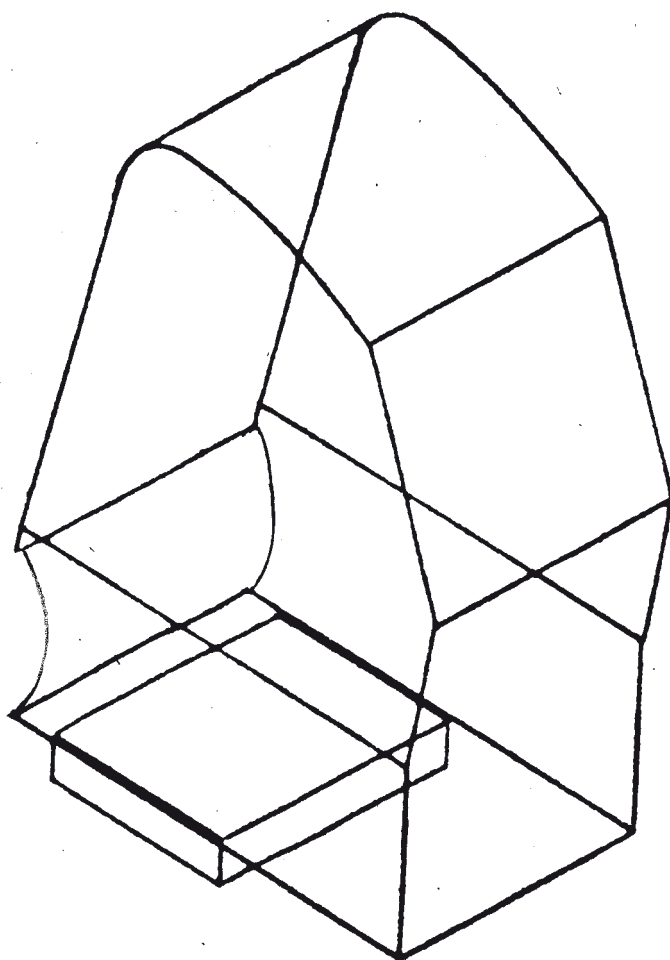

Figure 6c
Isometric view

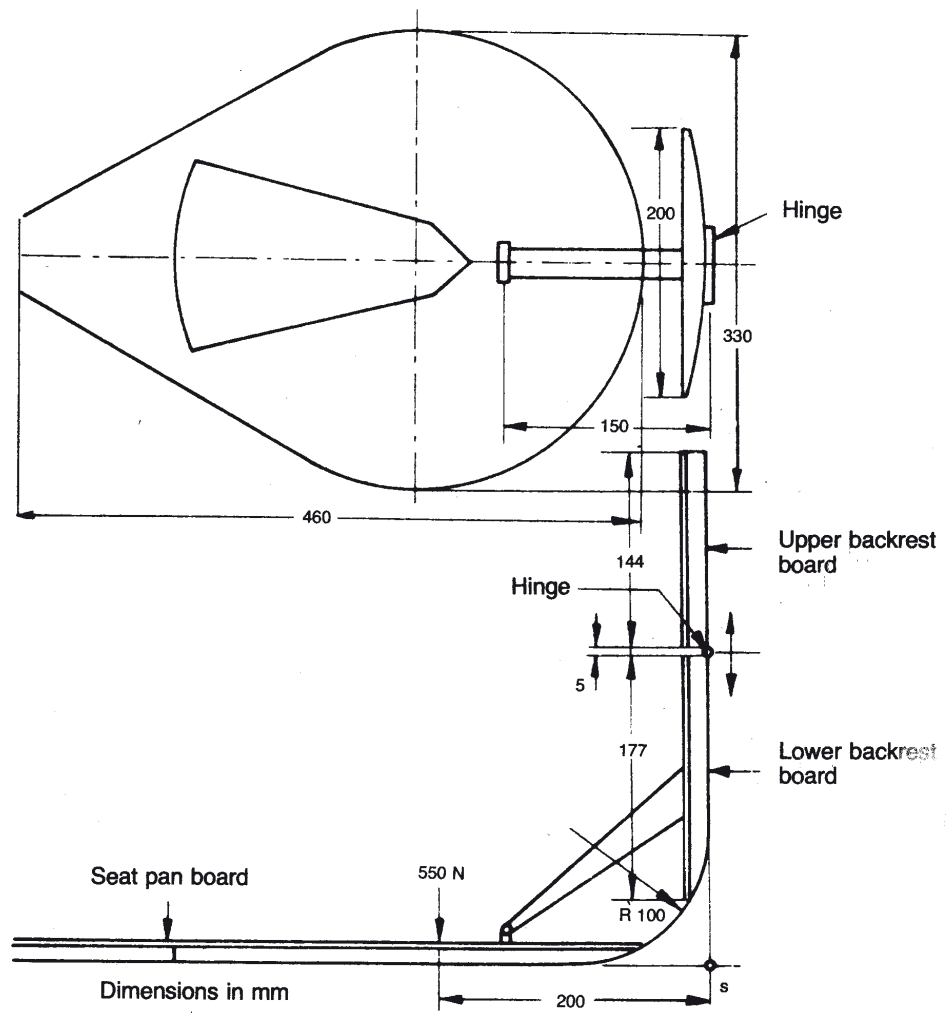

Figure 7
Apparatus for determination of seat reference point

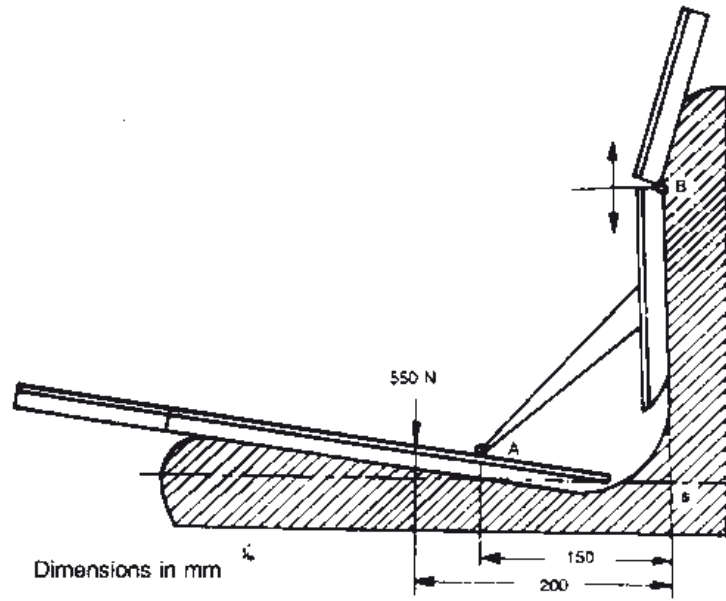

Figure 8

Method of determining seat reference point

ANNEX V

MODEL

Report relating to the EC component type-approval test of a protection structure (safety frame or cab) with regard to its strength as well as to the strength of its attachment to the tractor

(static testing)

Protection structure	
Make	
Type	
Tractor make	
Tractor type	

Identification of test station

EC component type-approval No

1. Trade mark or name of protection structure

2. Name and address of manufacturer of protection structure and/or tractor

3. If applicable, name and address of protection structure and/or tractor manufacturer's authorised representative

4. Specifications of tractor on which the tests are carried out

4.1. Trade mark or name

4.2. Type and commercial description

4.3. Serial number

4.4. Mass of unballasted tractor with protection structure fitted, without driver kg

Tyre sizes: front

rear

5. Extension(s) of EC component type-approval for other tractor (1)

5.1. Trade mark or name

(1) These details to be repeated for each extension.

5.2.	Type and commercial description	
5.3.	Mass of unballasted tractor, with protection structure fitted, without driver	kg
	Tyre sizes:	
	front	
	rear	
6.	Specifications of protection structure	
6.1.	General arrangement drawing of both the protection structure and its attachment to the tractor	
6.2.	Photographs from side and rear showing mounting details	
6.3.	Brief description of protection structure including type of construction, details of mounting on the tractor, details of cladding, means of access and escape, details of interior padding, features to prevent continuous rolling and details of heating and ventilation	
6.4.	Dimensions	
6.4.1.	Height of roof members above the seat reference point	mm
6.4.2.	Height of roof members above the tractor foot platform	mm
6.4.3.	Interior width of the protection structure at 900 mm above the seat reference point	mm
6.4.4.	Interior width of the protection structure at a point above the seat at the height of the centre of the steering wheel	mm
6.4.5.	Distance from the centre of the steering wheel to the right-hand side of the protection structure	mm
6.4.6.	Distance from the centre of the steering wheel to the left-hand side of the protection structure	mm
6.4.7.	Minimum distance from the steering wheel rim to the protection structure	mm
6.4.8.	Width of the doorways:	
	at the top	mm
	in the middle	mm
	at the bottom	mm
6.4.9.	Height of the doorways:	
	above foot platform	mm
	above highest mounting step	mm
	above lowest mounting step	mm

- 6.4.10. Overall height of the tractor with the protection structure fitted mm
- 6.4.11. Overall width of the protection structure (excluding the wings) mm
- 6.4.12. Horizontal distance to the rear of the protection structure from the seat reference point at a height of 900 mm mm
- 6.5. Details and quality of materials used, standards used
-
- Main frame (material and dimensions)
- Mountings (material and dimensions)
- Cladding (material and dimensions)
- Roof (material and dimensions)
- Interior padding (material and dimensions)
- Assembly and mounting bolts (grade and dimensions)
- Type of windscreen and glazing and details of marking
-
7. Test results
- 7.1. Loading and crushing tests
- Loading tests were made to the left/right hand ⁽¹⁾ rear and to the right/left hand ⁽¹⁾ front and right/left hand side ⁽¹⁾
- 7.2. The reference mass used for calculating energy input and crushing forces was kg
- 7.3. The requirements concerning cracks or tears and the protection of the zone of clearance were fulfilled
- 7.4. Loading energies:
- rear/front ⁽¹⁾ kJ
- side kJ
- Crushing force kN
- A second longitudinal loading test was made to the right/left hand front/rear ⁽¹⁾ kJ
- 7.5. Final permanent deflection measured after the tests:
- rear: forwards/backwards ⁽¹⁾
- left hand mm
- right hand mm
- front: forwards/backwards ⁽¹⁾
- left hand mm
- right hand mm

⁽¹⁾ Delete where inapplicable.

side sideways:

front mm

rear mm

top downwards/upwards ⁽¹⁾:

front mm

rear mm

8. Report number

9. Report date

10. Signature

⁽¹⁾ Delete where inapplicable.

ANNEX VI

MARKS

The EC component type-approval mark shall consist of a rectangle surrounding the lowercase letter 'e', followed by the distinguishing number of the Member State which has granted the component type-approval:

1. for Germany
2. for France
3. for Italy
4. for the Netherlands
5. for Sweden
6. for Belgium
7. for Hungary
8. for the Czech Republic
9. for Spain
11. for the United Kingdom
12. for Austria
13. for Luxembourg
17. for Finland
18. for Denmark
19. for Romania
20. for Poland
21. for Portugal
23. for Greece
24. for Ireland
26. for Slovenia
27. for Slovakia
29. for Estonia
32. for Latvia
34. for Bulgaria
36. for Lithuania
49. for Cyprus
50. for Malta

It must also include in the vicinity of the rectangle the EC component type-approval number which corresponds to the number of the EC component type-approval certificate issued with regard to the strength of the type of protection structure and its attachment to the tractor.

Example of an EC component type-approval mark

The EC component type-approval mark shall be supplemented by an additional symbol 'S'

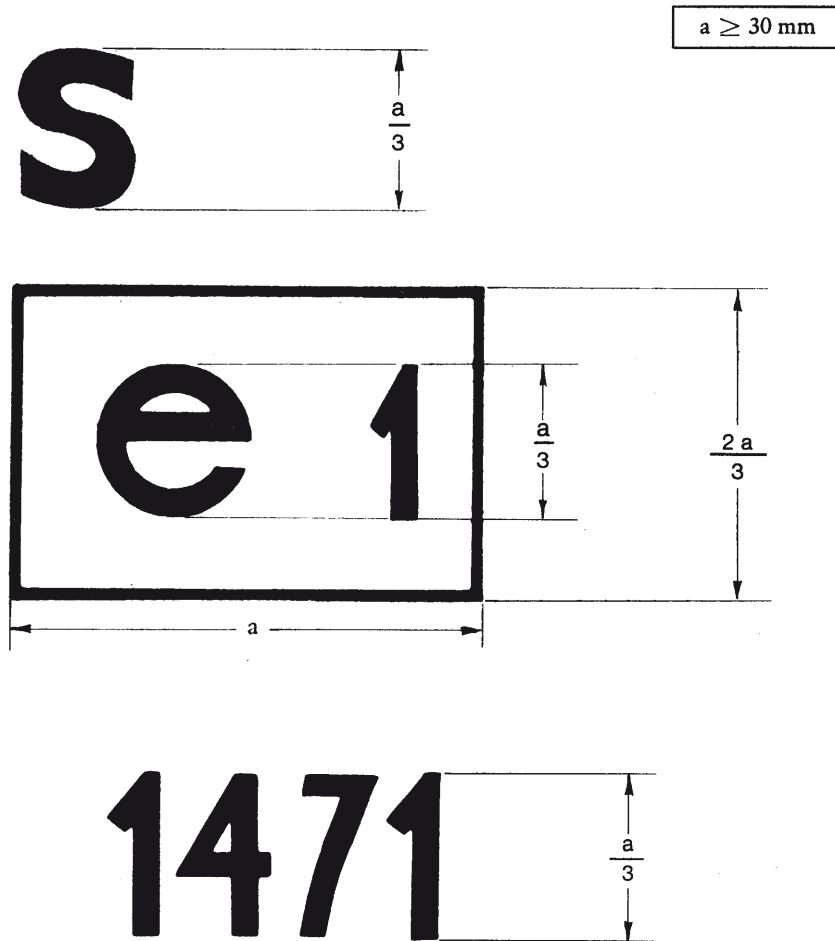

Legend: The protection structure bearing the EC component type-approval mark shown above is a protection structure for which EC component type-approval was granted in Germany (e 1) under the number 1471.

ANNEX VII

MODEL

EC COMPONENT TYPE-APPROVAL CERTIFICATE

Name of competent authority

Notification concerning the granting, refusal, withdrawal or extension of EC component type-approval with regard to the strength of a protection structure (safety cab or frame) and to the strength of its attachment to the tractor (static testing)

- EC component type-approval No extension (1)
1. Trade name or mark of protection structure
2. Name and address of manufacturer of protection structure
3. If applicable, name and address of authorised representative of manufacturer of protection structure
4. Trade mark or name, type and commercial description of tractor for which protection structure is intended
5. Extension of EC component type-approval for the following tractor type(s)
5.1. The mass of the unballasted tractor, as defined in 1.3 of Annex II, exceeds/does not exceed (2) the reference mass used for the test by more than 5 %.
5.2. The method of attachment and points of attachment are/are not (2) identical.
5.3. All the components likely to serve as supports for the protection structure are/are not (2) identical.
5.4. The requirements of the fourth indent of point 3.4 of Annex I are/are not (2) fulfilled.
6. Submitted for EC component type-approval on
7. Test station
8. Date and number of the report of the test station
9. Date of granting/refusal/withdrawal of EC component type-approval (2)
10. Date of granting/refusal/withdrawal of the extension of EC component type-approval (2)
11. Place
12. Date
13. The following documents, bearing the EC component type-approval number shown above, are annexed to this certificate (e.g. report of the test station)
14. Remarks, if any
15. Signature

(1) If applicable, state whether this is the first, second, etc. extension of the original EC component type-approval.
(2) Delete where inapplicable.

ANNEX VIII

Conditions for EC type-approval

1. The application for EC type-approval of a tractor, with regard to the strength of a protection structure and the strength of its attachment to the tractor, shall be submitted by the tractor manufacturer or by his authorised representative.
 2. A tractor representative of the tractor type to be approved, on which a protection structure and its attachment, duly approved, are mounted, shall be submitted to the technical services responsible for conducting the type-approval tests.
 3. The technical service responsible for conducting the type-approval tests shall check whether the approved type of protection structure is intended to be mounted on the type of tractor for which the type-approval is requested. In particular, it shall ascertain that the attachment of the protection structure corresponds to that which was tested when the EC component type-approval was granted.
 4. The holder of the EC type-approval may ask for its extension for other types of protection structures.
 5. The competent authorities shall grant such extension on the following conditions:
 - 5.1. the new type of protection structure and its tractor attachment have received EC component type-approval;
 - 5.2. it is designed to be mounted on the type of tractor for which the extension of the EC type-approval is requested;
 - 5.3. the attachment of the protection structure to the tractor corresponds to that which was tested when EC component type-approval was granted.
 6. A certificate, of which a model is shown in Annex IX, shall be annexed to the EC type-approval certificate for each type-approval or type-approval extension which has been granted or refused.
 7. If the application for EC type-approval for a type of tractor is introduced at the same time as the request for EC component type-approval for a type of protection structure intended to be mounted on the type of tractor for which EC type-approval is requested, the checks laid down in points 2 and 3 shall not be made.
-

ANNEX IX

MODEL

Name of competent authority

ANNEX TO THE EC TYPE-APPROVAL CERTIFICATE FOR A TRACTOR TYPE WITH REGARD TO THE STRENGTH OF PROTECTION STRUCTURES (SAFETY CAB OR FRAME) AND THE STRENGTH OF THEIR ATTACHMENT TO THE TRACTOR

(static testing)

(Article 4(2) of Directive 2003/37/EC of the European Parliament and of the Council of 26 May 2003 on type-approval of agricultural or forestry tractors, their trailers and interchangeable towed machinery, together with their systems, components and separate technical units and repealing Directive 74/150/EEC)

- EC component type-approval No extension (1)
1. Trade name or mark of tractor
2. Tractor type
3. Name and address of tractor manufacturer
4. If applicable, name and address of manufacturer's authorised representative
5. Trade name or mark of protection structure
6. Extension of EC type-approval for the following type(s) of protection structure
7. Tractor submitted for EC type-approval on
8. Technical service responsible for EC type-approval conformity control
9. Date of report issued by that service
10. Number of report issued by that service
11. EC type-approval with regard to the strength of the protection structures and the strength of their attachment to the tractor has been granted/refused (2)
12. The extension of the EC type-approval with regard to the strength of the protection structures and the strength of their attachment to the tractor has been granted/refused (2)
13. Place
14. Date
15. Signature

(1) If applicable, state whether this is the first, second, etc. extension of the original EC component type-approval.
(2) Delete where inapplicable.

ANNEX X

PART A

Repealed Directive with list of its successive amendments

(referred to in Article 13)

Council Directive 79/622/EEC
(OJ L 179, 17.7.1979, p. 1)

Commission Directive 82/953/EEC
(OJ L 386, 31.12.1982, p. 31)

Point IX.A.15.(h) of Annex I to the 1985 Act of
Accession
(OJ L 302, 15.11.1985, p. 213)

Council Directive 87/354/EEC
(OJ L 192, 11.7.1987, p. 43)

Only as regards references made to Directive
79/622/EEC in Article 1 and point 9(h) of
the Annex

Commission Directive 88/413/EEC
(OJ L 200, 26.7.1988, p. 32)

Point XI.C.II.4 of Annex I to the 1994 Act of Accession
(OJ C 241, 29.8.1994, p. 206)

Commission Directive 1999/40/EC
(OJ L 124, 18.5.1999, p. 11)

Point 1.A.29 of Annex II to the 2003 Act of Accession
(OJ L 236, 23.9.2003, p. 61)

Council Directive 2006/96/EC
(OJ L 363, 20.12.2006, p. 81)

Only as regards references made to Directive
79/622/EEC in Article 1 and point A.28 of
the Annex

PART B

List of time limits for transposition into national law

(referred to in Article 13)

Directive	Time limit for transposition
79/622/EEC	27 December 1980
82/953/EEC	30 September 1983 ⁽¹⁾
87/354/EEC	31 December 1987
88/413/EEC	30 September 1988 ⁽²⁾
1999/40/EC	30 June 2000 ⁽³⁾
2006/96/EC	31 December 2006

⁽¹⁾ In accordance with Article 2 of Directive 82/953/EEC:

1. With effect from 1 October 1983, no Member State may:

- refuse to grant EEC type-approval, to issue the documents referred to in the last indent of Article 10(1) of Directive 74/150/EEC or to grant national type-approval, in respect of a type of tractor, or
- prohibit the entry into service of tractors,

if the roll-over protection structure for this type of tractor or these tractors complies with the provisions of this Directive.

2. With effect from 1 October 1984, a Member State:

- shall no longer issue the document referred to in the last indent of Article 10(1) of Directive 74/150/EEC in respect of a type of tractor on which the roll-over protection structure does not comply with the provisions of this Directive,
- may refuse to grant national type-approval in respect of a type of tractor on which the rollover protection structure does not comply with the provisions of this Directive.

3. With effect from 1 October 1985, Member States may prohibit the entry into service of tractors on which the roll-over protection structure does not comply with the provisions of this Directive.

4. The provisions of paragraphs 1 to 3 shall be without prejudice to the provisions of Directive 77/536/EEC.

⁽²⁾ In accordance with Article 2 of Directive 88/413/EEC:

1. From 1 October 1988 no Member State may:

- refuse, in respect of a type of tractor, to grant EEC type-approval, to issue the document referred to in Article 10(1), final indent of Directive 74/150/EEC, or to grant national type-approval, or
- prohibit the entry into service of tractors,

if the roll-over protection structures of this type of tractor or tractors comply with the provisions of this Directive.

2. From 1 October 1989 Member States:

- shall not issue the document referred to in Article 10(1) final indent of Directive 74/150/EEC in respect of a type of tractor, the roll-over protection device of which does not comply with the provisions of this Directive,
- may refuse to grant national type-approval in respect of a type of tractor, the roll-over protection structure of which does not comply with the provisions of this Directive.

⁽³⁾ In accordance with Article 2 of Directive 1999/40/EC:

1. From 1 July 2000, Member States may not:

- refuse to grant EC type-approval, to issue the document provided for in the third indent of Article 10(1) of Directive 74/150/EEC, or to grant national type-approval, in respect of a type of tractor, or
- prohibit the entry into service of tractors,

if the tractors in question meet the requirements of Directive 79/622/EEC, as amended by this Directive.

2. From 1 January 2001, Member States:

- shall no longer issue the document provided for in the third indent of Article 10(1) of Directive 74/150/EEC in respect of any type of tractor which does not meet the requirements of Directive 79/622/EEC, as amended by this Directive,
- may refuse to grant national type-approval in respect of any type of tractor which does not meet the requirements of Directive 79/622/EEC, as amended by this Directive.

ANNEX XI

CORRELATION TABLE

Directive 79/622/EEC	Directive 1999/40/EC	This Directive
Articles 1 and 2		Articles 2 and 3
Article 3(1)		Article 4, first paragraph
Article 3(2)		Article 4, second and third paragraphs
Articles 4 and 5		Articles 5 and 6
Article 6, first sentence		Article 7, first paragraph
Article 6, second sentence		Article 7, second paragraph
	Article 2	Article 8
Article 8		Article 9
Article 9, introductory wording		Article 1, introductory wording
Article 9, first indent		Article 1, point (a)
Article 9, second indent		Article 1, point (b)
Article 9, third indent		Article 1, point (c)
Article 9, fourth indent		Article 1, point (d)
Articles 10 and 11		Articles 10 and 11
Article 12(1)		—
Article 12(2)		Article 12
—		Articles 13 and 14
Article 13		Article 15
Annexes I to IX		Annexes I to IX
—		Annex X
—		Annex XI