

Directive 2009/76/EC of the European Parliament and of the Council of 13 July 2009 relating to the driver-perceived noise level of wheeled agricultural or forestry tractors (Codified version) (Text with EEA relevance) (repealed)

## ANNEX I

### APPARATUS, CONDITIONS AND METHOD OF MEASUREMENT

#### 1. UNIT OF MEASUREMENT AND MEASURING APPARATUS

##### 1.1. Unit of measurement

Noise level  $L_A$  shall be measured in dB with A-weighting, expressed as dB(A).

##### 1.2. Measuring apparatus

Driver-perceived noise level shall be measured by means of a sound-level meter as described in the first edition of Publication No 179/1965 of the International Electrotechnical Commission.

In the case of variable readings, the average of the maximum values must be taken.

#### 2. CONDITIONS OF MEASUREMENT

Measurements shall be made under the following conditions:

2.1. the tractor must be unladen, i.e. without optional accessories, but must include coolant, lubricant, full fuel tank, tools and driver. The latter may not wear any abnormally thick clothing, scarf or hat. There may be no object on the tractor likely to distort the noise level;

2.2. the tyres must be inflated to the pressure recommended by the tractor manufacturer, the engine, transmission and drive axles must be at normal running temperature and radiator blinds when fitted must be kept open during measurements;

2.3. if it is liable to affect the noise level, extra equipment powered by the engine or self-powered such as windscreen wipers, warm air fan or power take-off, may not be in operation when measurements are being made; parts which normally operate at the same time as the engine, such as the engine cooling fan, must be in operation when measurements are being made;

2.4. the test area must be in an open and sufficiently silent location; it may take the form, for instance, of an open space of 50-metre radius, having a central part with a radius of at least 20 m which is practically level, or of a level section having a solid track with as flat a surface and as few gullies as possible. The track must be as clean and dry as possible (e.g. free of gravel, leaves, snow, etc.). Slopes and irregularities are acceptable only if the variations in noise level caused by them lie within the error tolerances of the measuring equipment;

2.5. the surface of the track must be such as not to cause excessive tyre noise;

2.6. the weather must be fine and dry with little or no wind.

The driver-perceived ambient noise level due to the wind or other sources of noise must be at least 10 dB(A) below the noise level of the tractor;

2.7. if a vehicle is used for measurements, it must be towed or driven at a sufficient distance from the tractor to avoid all interference. During measurements no object interfering with the measurements or reflective surfaces may be located within 20 m of each side of the test track or less than 20 m to the front or rear of the tractor. This condition can be considered fulfilled if the variations in noise level thus caused remain within the error tolerances; if not, the measurements must be discontinued for the duration of the interference;

2.8. all measurements in a given series must be carried out on the same track.

### 3. METHOD OF MEASUREMENT

3.1. The microphone must be located 250 mm to the side of the centre plane of the seat, the side being that on which the higher noise level is encountered.

The microphone diaphragm must face forward and the centre of the microphone must be 790 mm above and 150 mm forward of the seat reference point described in Annex III. Excessive vibration of the microphone must be avoided.

3.2. The maximum noise level in dB(A) shall be determined as follows:

3.2.1. all openings (e.g. doors, windows) in tractors having a closed series-produced cab structure must be closed during an initial series of measurements;

3.2.1.1. during a second series of measurements, they must be left open, provided that, when open, they do not create a road safety hazard, but fold-down or fold-up windscreens must remain closed;

3.2.2. noise must be measured using slow sound-level meter response at the load corresponding to the maximum noise in the gear giving the forward speed nearest to 7.5 km/h.

The governor control lever must be fully open. Starting with no load, the load applied must be increased until the maximum noise level is found. After each increase of load, time must be allowed for the noise level to stabilise before making the measurement;

3.2.3. noise must be measured using slow sound-level meter response at the load corresponding to the maximum noise in any gear other than that referred to in point 3.2.2 in which the noise level recorded is at least 1 dB(A) above that recorded in the gear referred to in point 3.2.2.

The governor control lever must be fully open. Starting with no load, the load applied must be increased until the maximum noise level is found. After each increase of load, time must be allowed for the noise level to stabilise before making the measurement;

3.2.4. noise must be measured at the maximum design speed of the unladen tractor.

3.3. The test report shall include noise-level measurements carried out under the following conditions:

3.3.1. in the gear giving the speed nearest to 7.5 km/h;

3.3.2. in any gear, if the conditions described in point 3.2.3 are fulfilled;

3.3.3. at maximum design speed.

### 4. ASSESSMENT CRITERIA

The measurements described in points 3.2.1, 3.2.2, 3.2.3 and 3.2.4 may not exceed the values laid down in Article 2.

## ANNEX II

### APPARATUS, CONDITIONS AND METHOD OF MEASUREMENT

#### 1. UNIT OF MEASUREMENT AND MEASURING APPARATUS

##### 1.1. Unit of measurement

Noise level  $L_A$  shall be measured in dB with A-weighting, expressed as dB(A).

##### 1.2. Measuring apparatus

Driver-perceived noise level shall be measured by means of a sound-level meter as described in the first edition of publication 179/1965 of the International Electrotechnical Commission.

In the case of variable readings, the average of the maximum values must be taken.

#### 2. CONDITIONS OF MEASUREMENT

Measurements shall be made under the following conditions:

2.1. the tractor must be unladen, i.e. without optional accessories, but must include coolant, lubricant; full fuel tank, tools and driver. The latter may not wear any abnormally thick clothing, scarf or hat. There may be no object on the tractor likely to distort the noise level;

2.2. the tyres must be inflated to the pressure recommended by the tractor manufacturer, the engine, transmission and drive axles must be at normal running temperature and, if the engine has cooling louvres, these must remain completely open;

2.3. if it is liable to affect the noise level, extra equipment powered by the engine or self-powered such as windscreen wipers, warm air fan or power take-off, for example, may not be in operation when measurements are being made; parts which normally operate at the same time as the engine, such as the engine cooling fan, for example, must be in operation when measurements are being made;

2.4. the test area must be in an open and sufficiently silent location: it may take the form, for instance, of an open space of 50-metre radius, having a central part with a radius of at least 20 m which is practically level, or of a level section having a solid track with as flat a surface and as few gullies as possible. The track must be as clean and dry as possible (e.g. free of gravel, leaves, snow, etc.). Slopes and irregularities are acceptable only if the variations in noise level caused by them lie within the error tolerances of the measuring equipment;

2.5. the surface of the track must be such as not to cause excessive tyre noise;

2.6. the weather must be fine and dry with little or no wind.

The driver-perceived ambient noise level due to the wind or other sources of noise must be at least 10 dB(A) below the noise level of the tractor;

2.7. if a vehicle is used for measurements, it must be towed or driven at a sufficient distance from the tractor to avoid all interference. During measurements no object interfering with the measurements or reflective surfaces may be located within 20 m of each side of the test track or less than 20 m to the front or rear of the tractor. This condition can be considered fulfilled if the variations in noise level thus caused remain within the error tolerances; if not, the measurements must be discontinued for the duration of the interference;

2.8. all measurements in a given series must be carried out on the same track.

### 3. METHOD OF MEASUREMENT

3.1. The microphone must be located 250 mm to the side of the central plane of the seat, the side being that on which the higher noise level is encountered.

The microphone diaphragm must face forward and the centre of the microphone shall be 790 mm above and 150 mm forward of the seat reference point described in Annex III. Excessive vibration of the microphone must be avoided.

3.2. Noise level shall be determined as follows:

3.2.1. the tractor must travel along the section at the same test speed at least three times for at least 10 seconds;

3.2.2. all openings (e.g. doors, windows) in tractors having a closed series-produced cab structure must be closed during an initial series of measurements;

3.2.2.1. during a second series of measurements they must be left open, provided that when open they do not create a road safety hazard, but fold-down or fold-up windscreens must remain closed;

3.2.3. noise must be measured at the maximum rpm using slow sound-level meter response i.e. in the gear giving the speed nearest to 7.5 km/h at the rated rpm. The tractor must be unladen when measurements are being made.

### 4. ASSESSMENT CRITERIA

The measurements described in points 3.2.2 and 3.2.3 may not exceed the values laid down in Article 2.

## ANNEX III

### DETERMINATION OF SEAT REFERENCE POINT

#### 1. DEFINITION

1.1. The seat reference point (S) shall be the point in the central longitudinal plane of the seat where the tangential plane of the lower backrest and a horizontal plane intersect. This horizontal plane cuts the lower surface of the seat-pan board 150 mm in front of the seat reference point.

#### 2. DETERMINATION OF SEAT REFERENCE POINT

2.1. The reference point shall be obtained using the device illustrated in figures 1 and 2 of the Appendix to this Annex, which makes it possible to simulate loading by a human occupant.

2.2. The seat must be set at the mid-point of the range allowed for vertical adjustment, this adjustment being independent of the horizontal adjustment. For the purposes of determining the microphone location referred to in point 3 of Annexes I and II, the seat must be at or as near as possible to the mid-point of the horizontal adjustment range.

#### 3. DESCRIPTION OF THE DEVICE

- 3.1. The device referred to in point 2.1 shall consist of a seat-pan board and two backrest boards.
- 3.2. The lower backrest board shall be jointed in the region of the ischium humps (A) and loin (B), the joint (B) being adjustable in height (see figure 2).

#### 4. SETTING UP THE DEVICE

The device shall be set up as follows:

- 4.1. the device shall be positioned on the seat;
- 4.2. it shall then be loaded with a force of 550 N at a point 50 mm in front of joint (A), and the two backrest boards shall be lightly pressed tangentially against the backrest;
- 4.3. if it is not possible to determine a definite tangent to the lower area of the backrest, the lower backrest board in vertical position must be lightly pressed against the backrest;
- 4.4. in the case of seats with a suspension adjustable to the driver's weight, the suspension shall be set so that the seat is at a point equidistant from its two extreme positions.

Appendix

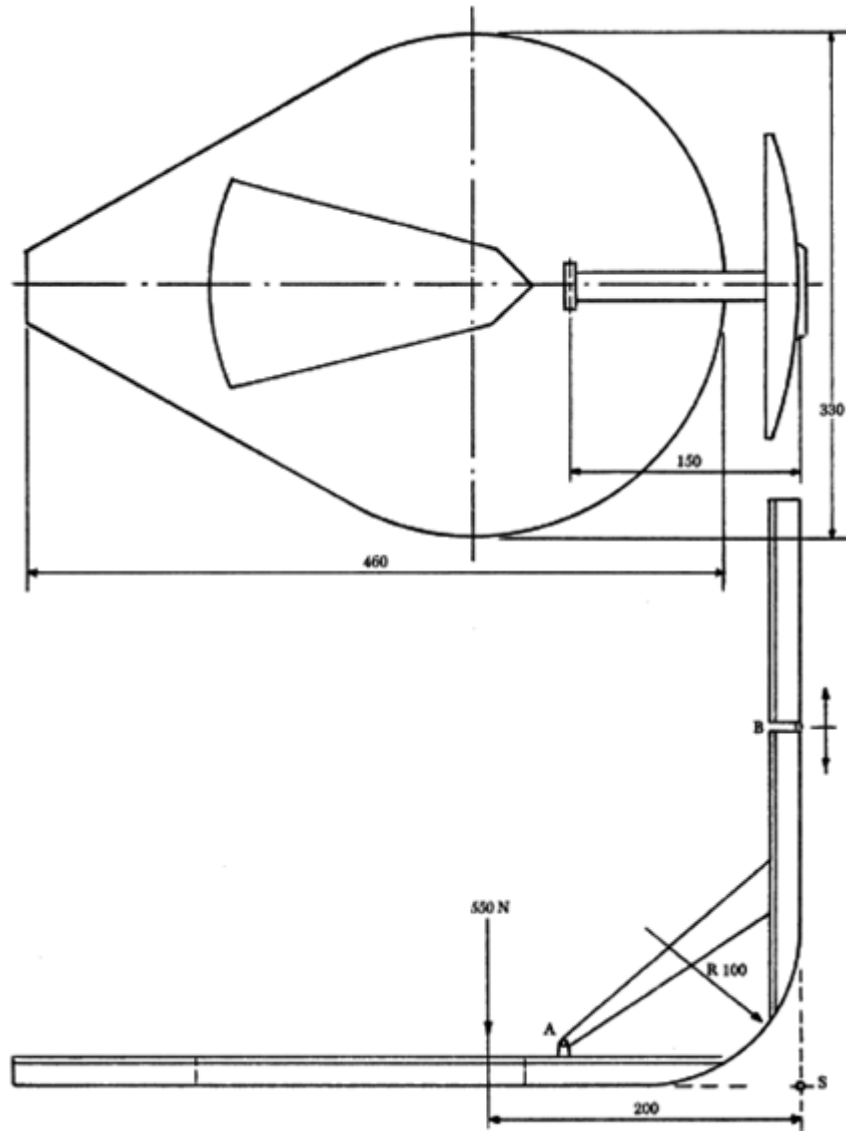

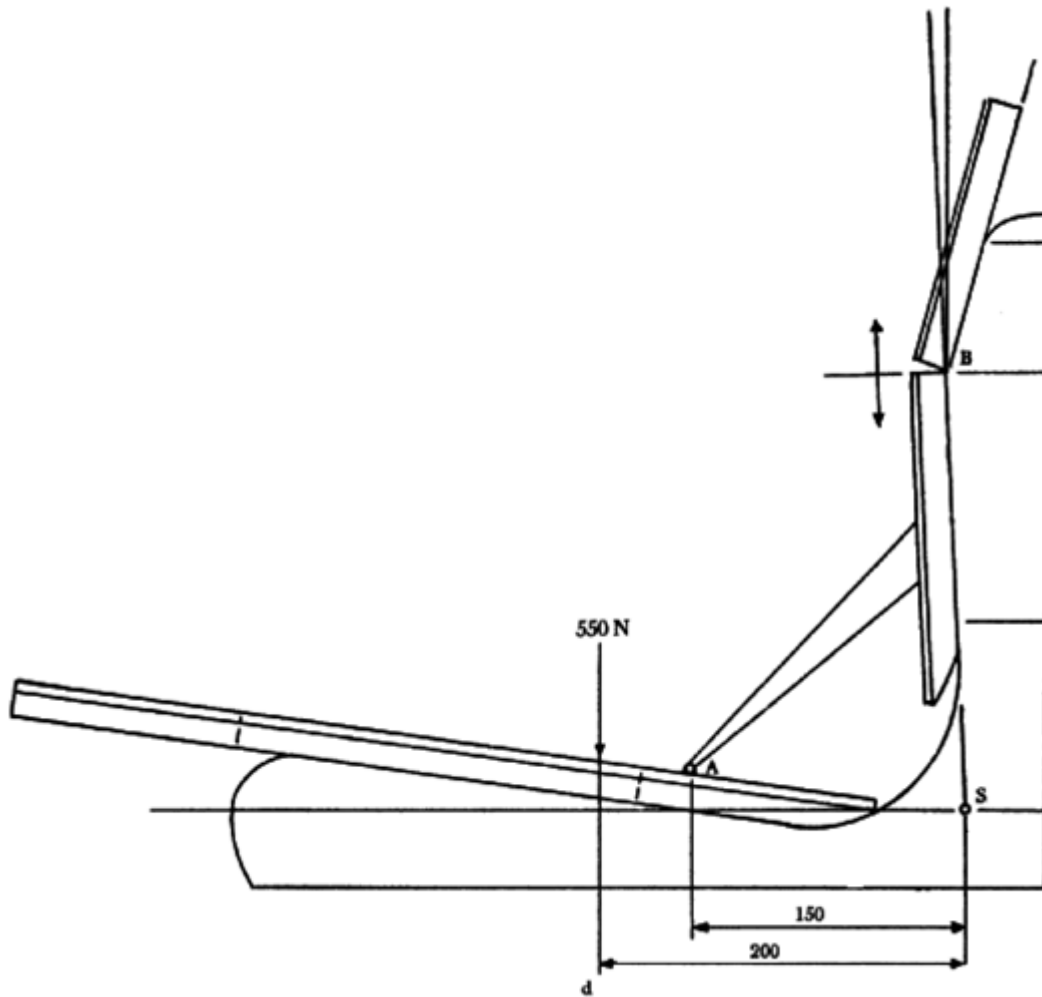

## ANNEX IV

## PART A

## REPEALED DIRECTIVE WITH LIST OF ITS SUCCESSIVE AMENDMENTS

(referred to in Article 7)

Council Directive 77/311/EEC (OJ L 105, 28.4.1977, p. 1).	
Council Directive 82/890/EEC (OJ L 378, 31.12.1982, p. 45).	Only the references made by Article 1(1) to Directive 77/311/EEC
Directive 97/54/EC of the European Parliament and of the Council (OJ L 277, 10.10.1997, p. 24).	Only the references made by Article 1, first indent, to Directive 77/311/EEC
Commission Decision 96/627/EC	



(OJ L 282, 1.11.1996, p. 72).	
Commission Decision 2000/63/EC (OJ L 22, 27.1.2000, p. 66).	
Commission Directive 2006/26/EC (OJ L 65, 7.3.2006, p. 22).	Only Article 2 and Annex II

## PART B

LIST OF TIME-LIMITS FOR TRANSPOSITION  
INTO NATIONAL LAW AND APPLICATION

(referred to in Article 7)

Act	Time-limit for transposition	Date of application
77/311/EEC	1 October 1978	—
82/890/EEC	22 June 1984	—
97/54/EC	22 September 1998	23 September 1998
96/627/EC	29 September 1999	—
2006/63/EC	30 September 2001	—
2006/26/EC	31 December 2006 <sup>a</sup>	—

**a** In accordance with Article 5 of Directive 2006/26/EC:

1. With effect from 1 January 2007, with respect to vehicles which comply with the requirements laid down respectively in Directives 74/151/EEC, 78/933/EEC, 77/311/EEC and 89/173/EEC, as amended by this Directive, Member States shall not, on grounds relating to the subject-matter of the Directive concerned:
2. With effect from 1 July 2007, with respect to vehicles which do not comply with the requirements laid down respectively in Directives 74/151/EEC, 78/933/EEC, 77/311/EEC and 89/173/EEC, as amended by this Directive, and on grounds relating to the subject-matter of the Directive concerned, Member States:
3. With effect from 1 July 2009, with respect to vehicles which do not comply with the requirements laid down respectively in Directives 74/151/EEC, 78/933/EEC, 77/311/EEC and 89/173/EEC, as amended by this Directive, and on grounds relating to the subject-matter of the Directive concerned, Member States:

## ANNEX V

## CORRELATION TABLE

Directive 77/311/EEC	Directive 2006/26/EC	This Directive
Article 1		Article 1
Article 2(1), first subparagraph		Article 2(1) and (4)
Article 2(1), second subparagraph		—

---

*Status: This is the original version (as it was originally adopted).*

---

Article 2(2)		—
	Article 5(2)	Article 2(2)
	Article 5(3)	Article 2(3)
Articles 3, 4 and 5		Article 3, 4 and 5
Article 6(1)		—
Article 6(2)		Article 6
		Article 7
		Article 8
Article 7		Article 9
Annex I		Annex I
Annex II		Annex II
Annex III		Annex III
—		Annex IV
—		Annex V