

This document is meant purely as a documentation tool and the institutions do not assume any liability for its contents

► **B** REGULATION (EC) No 2003/2003 OF THE EUROPEAN PARLIAMENT AND OF THE COUNCIL
of 13 October 2003
relating to fertilisers
(Text with EEA relevance)
(OJ L 304, 21.11.2003, p. 1)

Amended by:

		Official Journal		
		No	page	date
► <u>M1</u>	Council Regulation (EC) No 885/2004 of 26 April 2004	L 168	1	1.5.2004
► <u>M2</u>	Commission Regulation (EC) No 2076/2004 of 3 December 2004	L 359	25	4.12.2004
► <u>M3</u>	Council Regulation (EC) No 1791/2006 of 20 November 2006	L 363	1	20.12.2006
► <u>M4</u>	Commission Regulation (EC) No 162/2007 of 19 February 2007	L 51	7	20.2.2007
► <u>M5</u>	Commission Regulation (EC) No 1107/2008 of 7 November 2008	L 299	13	8.11.2008
► <u>M6</u>	Regulation (EC) No 219/2009 of the European Parliament and of the Council of 11 March 2009	L 87	109	31.3.2009
► <u>M7</u>	Commission Regulation (EC) No 1020/2009 of 28 October 2009	L 282	7	29.10.2009
► <u>M8</u>	Commission Regulation (EU) No 137/2011 of 16 February 2011	L 43	1	17.2.2011
► <u>M9</u>	Commission Regulation (EU) No 223/2012 of 14 March 2012	L 75	12	15.3.2012



**REGULATION (EC) No 2003/2003 OF THE EUROPEAN
PARLIAMENT AND OF THE COUNCIL**

of 13 October 2003

relating to fertilisers

(Text with EEA relevance)

THE EUROPEAN PARLIAMENT AND THE COUNCIL OF THE
EUROPEAN UNION,

Having regard to the Treaty establishing the European Community, and
in particular Article 95 thereof,

Having regard to the proposal from the Commission ⁽¹⁾,

Having regard to the Opinion of the European Economic and Social
Committee ⁽²⁾,

Acting in accordance with the procedure laid down in Article 251 of the
Treaty ⁽³⁾,

Whereas:

- (1) Council Directive 76/116/EEC of 18 December 1975 on the approximation of the laws of the Member States relating to fertilisers ⁽⁴⁾, Council Directive 80/876/EEC of 15 July 1980 on the approximation of the laws of the Member States relating to straight ammonium nitrate fertilisers of high nitrogen content ⁽⁵⁾, Commission Directive 87/94/EEC of 8 December 1986 on the approximation of the laws of the Member States relating to procedures for the control of characteristics of, limits for and resistance to detonation of straight ammonium nitrate fertilisers of high nitrogen content ⁽⁶⁾, and Commission Directive 77/535/EEC of 22 June 1977 on the approximation of the laws of the Member States relating to methods of sampling and analysis for fertilisers ⁽⁷⁾, have been substantially amended several times. In accordance with the communication from the Commission to the European Parliament and the Council 'Simpler legislation for the internal market' (SLIM) and the Action Plan for the Single Market those Directives should be repealed and replaced by a single legal instrument, in the interests of clarity.
- (2) The Community legislation on fertilisers is very technical in its content. A Regulation is therefore the most appropriate legal instrument, as it imposes directly on manufacturers precise requirements to be applied at the same time and in the same manner throughout the Community.

⁽¹⁾ OJ C 51 E, 26.2.2002, p. 1 and OJ C 227 E, 24.9.2002, p. 503.

⁽²⁾ OJ C 80, 3.4.2002, p. 6.

⁽³⁾ Opinion of the European Parliament of 10 April 2002 (OJ C 127 E, 29.5.2002, p. 160), Council Common Position of 14 April 2003 (OJ C 153 E, 1.7.2003, p. 56) and Decision of the European Parliament of 2 September 2003 (not yet published in the Official Journal).

⁽⁴⁾ OJ L 24, 30.1.1976, p. 21. Directive as last amended by Directive 98/97/EC of the European Parliament and the Council (OJ L 18, 23.1.1999, p. 60).

⁽⁵⁾ OJ L 250, 23.9.1980, p. 7. Directive as amended by Directive 97/63/EC of the European Parliament and the Council (OJ L 335, 6.12.1997, p. 15).

⁽⁶⁾ OJ L 38, 7.2.1987, p. 1. Directive as amended by Directive 88/126/EEC (OJ L 63, 9.3.1988, p. 12).

⁽⁷⁾ OJ L 213, 22.8.1977, p. 1. Directive as last amended by Directive 95/8/EC (OJ L 86, 20.4.1995, p. 41).

▼B

- (3) In each Member State fertilisers must display certain technical characteristics laid down by mandatory provisions. These provisions, concerning more particularly the composition and definition types of fertilisers, the designations of these types, their identification and their packaging, differ from one Member State to another. By their disparity they hinder trade within the Community and should therefore be harmonised.
- (4) Since the objective of the proposed action, namely to ensure the internal market in fertilisers, cannot be sufficiently achieved by the Member States if there are no common technical criteria and can therefore, by reason of the scale of the action, be better achieved at Community level, the Community may adopt measures in accordance with the principle of subsidiarity as set out in Article 5 of the Treaty. In accordance with the principle of proportionality, as set out in that Article, this Regulation does not go beyond what is necessary in order to achieve this objective.
- (5) It is necessary to determine at Community level the designation, definition and composition of certain fertilisers (EC fertilisers).
- (6) Community rules on the identification, traceability and labelling of EC fertilisers and on the closure of the packages should also be laid down.
- (7) A procedure should be established at Community level to be followed in cases where a Member State deems it necessary to restrict the placing on the market of EC fertilisers.
- (8) The production of fertilisers is subject to varying degrees of fluctuation due to manufacturing techniques or basic materials. Sampling and analytical procedures may also contain variations. It is therefore necessary to authorise tolerances on the declared nutrient contents. In the interest of the agricultural user, it is advisable to keep these tolerances within narrow limits.
- (9) Official controls on the compliance of EC fertilisers with requirements of this Regulation concerning quality and composition should be carried out by laboratories that are approved by the Member States and notified to the Commission.
- (10) Ammonium nitrate is the essential ingredient of a variety of products, some of which are intended for use as fertilisers and others as explosives. It is necessary, having regard to the particular nature of ammonium nitrate fertilisers of high nitrogen content and to the consequent requirements regarding public safety, health and protection of workers, to lay down additional Community rules for EC fertilisers of this type.
- (11) Certain of those products could be hazardous and could in certain instances be used for purposes other than those for which they were intended. This could well endanger the security of persons and property. Manufacturers should therefore be obliged to take appropriate steps to avoid such use, and in particular to ensure the traceability of such fertilisers.
- (12) In the interest of public safety, it is particularly important to determine at Community level the characteristics and properties distinguishing ammonium nitrate EC fertilisers of high nitrogen content from varieties of ammonium nitrate used in the manufacture of products used as explosives.

▼B

- (13) Ammonium nitrate EC fertilisers of high nitrogen content should conform to certain characteristics to ensure that they are harmless. Manufacturers should ensure that all high nitrogen content ammonium nitrate fertilisers have passed a test of resistance to detonation before those fertilisers are placed on the market.
- (14) It is necessary to establish rules on the methods of the closed thermal cycles even if these methods may not necessarily simulate all conditions arising during transport and storage.
- (15) Fertilisers can be contaminated by substances that can potentially pose a risk to human and animal health and the environment. Further to the opinion of the Scientific Committee on Toxicity, Ecotoxicity and the Environment (SCTEE), the Commission intends to address the issue of unintentional cadmium content in mineral fertilisers and will, where appropriate, draw up a proposal for a Regulation, which it intends to present to the European Parliament and the Council. Where appropriate, a similar review will be undertaken for other contaminants.
- (16) It is appropriate to establish a procedure, to be observed by any manufacturer or its representative that wishes to include a new type of fertiliser in Annex I in order to use the marking 'EC fertiliser'.
- (17) The measures necessary for the implementation of this Regulation should be adopted in accordance with Council Decision 1999/468/EC of 28 June 1999 laying down the procedures for the exercise of implementing powers conferred on the Commission ⁽¹⁾.
- (18) Member States should lay down penalties in respect of infringements of the provisions of this Regulation. They may provide that a manufacturer which infringes Article 27 can be fined an amount equivalent to ten times the market value of the shipment that fails to comply.
- (19) Directives 76/116/EEC, 77/535/EEC, 80/876/EEC and 87/94/EEC should be repealed,

HAVE ADOPTED THIS REGULATION:

TITLE I

GENERAL PROVISIONS

CHAPTER I

Scope and definitions

Article 1

Scope

This Regulation shall apply to products which are placed on the market as fertilisers designated 'EC fertiliser'.

⁽¹⁾ OJ L 184, 17.7.1999, p. 23.

▼B*Article 2***Definitions**

For the purposes of this Regulation the following definitions shall apply:

- (a) 'Fertiliser' means material, the main function of which is to provide nutrients for plants.
- (b) 'Primary nutrient' means the elements nitrogen, phosphorus and potassium only.
- (c) 'Secondary nutrient' means the elements calcium, magnesium, sodium and sulphur.
- (d) 'Micro-nutrients' means the elements boron, cobalt, copper, iron, manganese, molybdenum and zinc, essential for plant growth in quantities that are small compared with those of primary and secondary nutrients.
- (e) 'Inorganic fertiliser' means a fertiliser in which the declared nutrients are in the form of minerals obtained by extraction or by physical and/or chemical industrial processes. Calcium cyanamide, urea and its condensation and association products, and fertilisers containing chelated or complexed micro-nutrients may, by convention, be classed as inorganic fertilisers.
- (f) 'Chelated micro-nutrient' means a micro-nutrient that is held by one of the organic molecules listed in section E.3.1 of Annex I.
- (g) 'Complexed micro-nutrient' means a micro-nutrient that is held by one of the molecules listed in section E.3.2 of Annex I.
- (h) 'Type of fertilisers' means fertilisers with a common type designation as indicated in Annex I.
- (i) 'Straight fertiliser' means a nitrogenous, phosphatic or potassic fertiliser having a declarable content of only one of the primary nutrients.
- (j) 'Compound fertiliser' means a fertiliser having a declarable content of at least two of the primary nutrients and obtained chemically or by blending or by a combination of both.
- (k) 'Complex fertiliser' means a compound fertiliser, obtained by chemical reaction, by solution, or in its solid state by granulation, having a declarable content of at least two of the primary nutrients. In its solid state each granule contains all the nutrients in their declared composition.
- (l) 'Blended fertiliser' means a fertiliser obtained by dry mixing of several fertilisers, with no chemical reaction.
- (m) 'Foliar fertiliser' means a fertiliser suitable for application to and nutrient uptake by the foliage of a crop.
- (n) 'Fluid fertiliser' means a fertiliser in suspension or solution.
- (o) 'Solution fertiliser' means a fluid fertiliser that is free of solid particles.
- (p) 'Suspension fertiliser' means a two-phase fertiliser in which solid particles are maintained in suspension in the liquid phase.
- (q) 'Declaration' means a statement of the amount of nutrients, including their forms and solubility, guaranteed within specified tolerances.

▼B

- (r) 'Declared content' means the content of an element, or its oxide, which, in accordance with Community legislation, is given on a label of an EC fertiliser or on the relevant accompanying document.
- (s) 'Tolerance' means the permitted deviation of the measured value of a nutrient content from its declared value.
- (t) 'European Standard' means CEN (European Committee for Standardisation) standards, which have been officially recognised by the Community and whose reference has been published in the *Official Journal of the European Communities*.
- (u) 'Package' means a sealable receptacle used to hold, protect, handle, and distribute fertilisers and holding not more than 1 000 kg.
- (v) 'Bulk' means a fertiliser not packaged as prescribed by this Regulation.
- (w) 'Placing on the market' means the supply of fertiliser, whether in return for payment or free of charge, or storage for the purpose of supply. Importation of a fertiliser into the customs territory of the European Community shall be deemed to constitute placing on the market.
- (x) 'Manufacturer' means the natural or legal person responsible for placing a fertiliser on the market; in particular a producer, an importer, a packager working for its own account, or any person changing the characteristics of a fertiliser, shall be deemed to be a manufacturer. However, a distributor who does not change the characteristics of the fertiliser shall not be deemed to be a manufacturer.

*CHAPTER II****Placing on the market****Article 3***EC Fertiliser**

A fertiliser belonging to a type of fertilisers listed in Annex I and complying with the conditions laid down in this Regulation, may be designated 'EC fertiliser'.

The designation 'EC fertiliser' shall not be used for a fertiliser which does not comply with this Regulation.

*Article 4***Establishment within the Community**

The manufacturer shall be established within the Community and shall be responsible for the conformity of the 'EC fertiliser' with the provisions of this Regulation.

*Article 5***Free circulation**

1. Without prejudice to Article 15 and other Community legislation, Member States shall not, on grounds of composition, identification, labelling or packaging, and other provisions contained in this Regulation, prohibit, restrict or hinder the placing on the market of fertilisers marked 'EC fertiliser' which comply with the provisions of this Regulation.

▼B

2. Fertilisers that are marked 'EC fertiliser' in accordance with this Regulation shall circulate freely within the Community.

*Article 6***Compulsory statements**

1. In order to satisfy the requirements of Article 9, Member States may prescribe that the indication of the nitrogen, phosphorus and potassium contents of fertilisers placed on their market is to be expressed in the following way:

- (a) nitrogen solely in the elemental form (N); and either
- (b) phosphorus and potassium solely in the elemental form (P, K); or
- (c) phosphorus and potassium solely in the oxide form (P_2O_5 , K_2O); or
- (d) phosphorus and potassium in both elemental and oxide forms simultaneously.

Where the option is chosen to prescribe that the phosphorus and potassium contents be expressed in the form of elements, all references in the Annexes to the oxide form shall be read as being in elemental form and the numerical values shall be converted using the following factors:

- (a) phosphorus (P) = phosphorus pentoxide (P_2O_5) \times 0,436;
- (b) potassium (K) = potassium oxide (K_2O) \times 0,830.

2. Member States may prescribe that the calcium, magnesium, sodium and sulphur contents of secondary nutrient fertilisers and, where the conditions of Article 17 are fulfilled, of primary nutrient fertilisers placed on their markets are to be expressed:

- (a) in the oxide form (CaO, MgO, Na_2O , SO_3); or
- (b) in the elemental form (Ca, Mg, Na, S); or
- (c) in both of these forms.

To convert the calcium oxide, magnesium oxide, sodium oxide and sulphur trioxide contents into calcium, magnesium, sodium and sulphur contents, the following factors shall be used:

- (a) calcium (Ca) = calcium oxide (CaO) \times 0,715;
- (b) magnesium (Mg) = magnesium oxide (MgO) \times 0,603;
- (c) sodium (Na) = sodium oxide (Na_2O) \times 0,742;
- (d) sulphur (S) = sulphur trioxide (SO_3) \times 0,400.

For the calculated oxide or elemental content, the figure declared shall be rounded to the nearest decimal place.

3. Member States shall not prevent the placing on the market of an 'EC fertiliser' labelled in both of the forms mentioned in paragraphs 1 and 2.

▼B

4. The content of one or more of the micro-nutrients boron, cobalt, copper, iron, manganese, molybdenum, or zinc in the EC fertilisers belonging to the types of fertilisers listed in sections A, B, C and D of Annex I shall be declared where the following conditions are fulfilled:

- (a) the micro-nutrients are added at least in the minimum quantities specified in section E.2.2 and E.2.3 of Annex I;
- (b) the EC fertiliser continues to satisfy the requirements of sections A, B, C and D of Annex I.

5. Where the micro-nutrients are the normal ingredients of the raw materials intended to supply primary (N, P, K) and secondary (Ca, Mg, Na, S) nutrients, they may be declared, provided that these micro-nutrients are present at least in the minimum quantities specified in sections E.2.2 and E.2.3 of Annex I.

6. The micro-nutrient content shall be declared in the following manner:

- (a) for fertilisers belonging to the types of fertilisers listed in section E.1 of Annex I, in accordance with the requirements set out in column 6 of that section;
- (b) for mixtures of fertilisers referred to in (a) containing at least two different micro-nutrients and meeting the requirements of section E.2.1 of Annex I and for fertilisers belonging to the types of fertilisers listed in sections A, B, C and D of Annex I, by indicating:
 - (i) the total content, expressed as a percentage of the fertiliser by mass,
 - (ii) the water-soluble content, expressed as a percentage of the fertiliser by mass, where the soluble content is at least half of the total content.

Where a micro-nutrient is totally water-soluble, only the water-soluble content shall be declared.

Where a micro-nutrient is chemically linked with an organic molecule, the content of the micro-nutrient present in the fertiliser shall be declared immediately following the water-soluble content as a percentage by mass of the product, followed by one of the terms 'chelated by', or 'complexed by', with the name of the organic molecule as set out in section E.3 of Annex I. The name of the organic molecule may be replaced by its initials.

*Article 7***Identification**

1. The manufacturer shall provide EC fertilisers with the identification markings listed in Article 9.

2. If the fertilisers are packed, these identification markings shall appear on the packages or labels attached. If the fertilisers are in bulk, these markings shall appear on the accompanying documents.



Article 8

Traceability

Without prejudice to Article 26(3), the manufacturer shall, to ensure traceability of EC fertilisers, maintain records of the origin of the fertilisers. These records shall be available for inspection by Member States for as long as the fertiliser is being supplied to the market, and for a further period of 2 years after the manufacturer stopped supplying it.

Article 9

Markings

1. Without prejudice to other Community rules, the packages, labels and accompanying documents, referred to in Article 7 shall bear the following markings:

(a) Compulsory identification

- The words ‘EC FERTILISER’ in capital letters;
- Where it exists, the designation of the type of fertiliser as set out in Annex 1;
- For blended fertilisers, the marking ‘blend’ after the designation of the type;
- The additional markings specified in Article 19, 21 or 23;
- Nutrients shall be indicated both in words and by the appropriate chemical symbols, e.g. nitrogen (N), phosphorus (P), phosphorus pentoxide (P₂O₅), potassium (K), potassium oxide (K₂O), calcium (Ca), calcium oxide (CaO), magnesium (Mg), magnesium oxide (MgO), sodium (Na), sodium oxide (Na₂O), sulphur (S), sulphur trioxide (SO₃), boron (B), copper (Cu), cobalt (Co), iron (Fe), manganese (Mn), molybdenum (Mo), zinc (Zn);
- If the fertiliser contains micro-nutrients of which all or part are chemically linked with an organic molecule, the name of the micro-nutrient shall be followed by one of the following qualifiers:
 - (i) ‘chelated by ...’ (name of chelating agent or its abbreviation as set out in section E.3.1 of Annex I);
 - (ii) ‘complexed by ...’ (name of complexing agent as set out in section E.3.2 of Annex I);
- Micro-nutrients contained in the fertiliser, listed in the alphabetical order of their chemical symbols: B, Co, Cu, Fe, Mn, Mo, Zn;
- For products listed in sections E.1 and E.2 of Annex I, the specific directions for use;
- Quantities of fluid fertilisers, expressed by mass. The expression of quantities of fluid fertilisers by volume or in terms of mass versus volume (kilograms per hectolitre or grams per litre) shall be optional;
- Net or gross mass and, optionally, volume for fluid fertilisers. If the gross mass is given, the tare mass must be indicated beside it;
- The name or trade name and the address of the manufacturer.

▼B

(b) Optional identification

- As listed in Annex I;
- The directions for the storage and handling, and for fertilisers not listed in Annex I, sections E.1 and E.2, the specific directions for the use of the fertiliser;
- Indications of the dose rates and conditions of use suitable for the soil and crop conditions under which the fertiliser is used;
- The mark of the manufacturer and the trade description of the product.

The indications referred to in (b) must not conflict with those referred to in (a) and must be clearly separated from them.

2. All the markings referred to in paragraph 1 must be clearly separated from any other information on the packages, labels and accompanying documents.
3. Fluid fertilisers may be placed on the market only if the manufacturer provides suitable additional instructions covering, in particular, storage temperature and prevention of accidents during storage.
4. Detailed rules for the application of this Article shall be adopted under the procedure referred to in Article 32(2).

*Article 10***Labelling**

1. The labels or markings printed on the package and giving the particulars mentioned under Article 9 must be placed in a conspicuous position. Labels must be attached to the package or to whatever system is used for closing it. If this system consists of a seal, that seal must bear the name or mark of the packager.
2. The markings referred to in paragraph 1 must be and must remain indelible and clearly legible.
3. In the cases of fertilisers in bulk referred to in the second sentence of Article 7(2) a copy of the documents containing the identification markings must accompany the goods and be accessible for inspection purposes.

*Article 11***Languages**

The label, the markings on the package and the accompanying documents must appear in at least the national language or languages of the Member State in which the EC fertiliser is marketed.

*Article 12***Packaging**

In the case of packaged EC fertilisers, the package must be closed in such a way or by such a device that, when it is opened, the fastening, fastening seal or the package itself is irreparably damaged. Valve sacks may be used.

▼B*Article 13***Tolerances**

1. The nutrient content of EC fertilisers shall comply with the tolerances established in Annex II, which are intended to allow for deviations in manufacture, sampling and analysis.
2. The manufacturer shall not take systematic advantage of the tolerances given in Annex II.
3. No tolerances are allowed in respect of the minimum and maximum contents specified in Annex I.

*Article 14***Fertiliser requirements**

A type of fertiliser may only be included in Annex I if:

- (a) it provides nutrients in an effective manner;
- (b) relevant sampling, analysis, and if required, test methods are being provided;
- (c) under normal conditions of use it does not adversely affect human, animal, or plant health, or the environment.

*Article 15***Safeguard clause**

1. Where a Member State has justifiable grounds for believing that a specific EC fertiliser, although satisfying the requirements of this Regulation, constitutes a risk to safety or health of humans, animals or plants or a risk to the environment, it may temporarily prohibit the placing on the market of that fertiliser in its territory or make it subject to special conditions. It shall immediately inform the other Member States and the Commission thereof, giving the reasons for its decision.
2. The Commission shall adopt a decision on the matter within 90 days from the receipt of the information in accordance with the procedure referred to in Article 32(2).
3. The provisions of this Regulation shall not preclude the taking of measures by the Commission or by a Member State which are justified on grounds of public security to prohibit, restrict or hinder the placing on the market of EC fertilisers.



TITLE II
PROVISIONS FOR SPECIFIC TYPES OF FERTILISERS

CHAPTER I
Inorganic primary nutrient fertilisers

Article 16

Scope

This chapter shall apply to inorganic primary nutrient fertilisers, solid or fluid, straight or compound, including those containing secondary nutrients and/or micro-nutrients, with the minimum nutrient content established in sections A, B, C, E.2.2 or E.2.3 of Annex I.

Article 17

Declaration of secondary nutrients in primary nutrient fertilisers

Calcium, magnesium, sodium and sulphur content may be declared as secondary nutrient content of EC fertilisers belonging to the types of fertiliser listed in sections A, B and C of Annex I, provided that these elements are present in at least the following minimum quantities:

- (a) 2 % calcium oxide (CaO), i.e. 1,4 % Ca;
- (b) 2 % of magnesium oxide (MgO), i.e. 1,2 % Mg;
- (c) 3 % of sodium oxide (Na₂O), i.e. 2,2 % Na;
- (d) 5 % of sulphur trioxide (SO₃), i.e. 2 % S.

In such a case, the additional marking specified in Article 19(2)(ii) shall be added to the type designation.

Article 18

Calcium, magnesium, sodium and sulphur

1. The declaration of the magnesium, sodium and sulphur content of the fertilisers listed in sections A, B, and C of Annex I shall be expressed in one of the following ways:

- (a) the total content expressed as a percentage of the fertiliser by mass;
- (b) the total content and the content soluble in water, expressed as a percentage of the fertiliser by mass where the soluble content is at least a quarter of the total content;
- (c) where an element is totally soluble in water, only the content soluble in water shall be declared as a percentage of the mass.

2. Unless otherwise stated in Annex I, a declaration of the calcium content shall only be made if it is soluble in water and shall be expressed as a percentage of the fertiliser by mass.

▼B*Article 19***Identification**

1. In addition to the compulsory identification markings referred to in Article 9(1)(a), the markings set out in paragraphs 2, 3, 4, 5 and 6 of this Article shall be stated.
2. The following shall be stated after the type designation of compound fertilisers:
 - (i) The chemical symbols of the declared secondary nutrients, between brackets and after the symbols of the primary nutrients.
 - (ii) Numbers indicating the primary nutrient content. The declared secondary nutrient content shall be indicated between brackets after the primary nutrient content.
3. The fertiliser type designation shall only be followed by figures indicating primary and secondary nutrient content.
4. Where micro-nutrients are declared, the words 'with micro-nutrients' or the word 'with' followed by the name or names and chemical symbols of the micro-nutrients present shall be given.
5. The declared content of primary nutrients and secondary nutrients shall be given as a percentage by mass, as whole numbers or, where necessary, where an appropriate method of analysis exists, to one decimal place.

In fertilisers containing more than one declared nutrient, the order shall be for primary nutrients: N, P₂O₅ and/or P, K₂O and/or K, and for secondary nutrients: CaO and/or Ca, MgO and/or Mg, Na₂O and/or Na, SO₃ and/or S.

The declared content of micro-nutrients shall give the name and symbol of each micro-nutrient, indicating the percentage by mass as specified in sections E.2.2 and E.2.3 of Annex I and according to solubility.

6. The forms and solubility of the nutrients shall also be expressed as a percentage by mass of fertiliser, except where Annex I explicitly provides that this content shall be otherwise expressed.

The number of decimal places shall be one, except for micro-nutrients where it shall be as specified in sections E.2.2 and E.2.3 of Annex I.

*CHAPTER II**Inorganic secondary nutrient fertilisers**Article 20***Scope**

This chapter shall apply to inorganic secondary nutrient fertilisers, solid or fluid, including those containing micro-nutrients, with the minimum nutrient content established in sections D, E.2.2, and E.2.3 of Annex I.



Article 21

Identification

1. In addition to the compulsory identification markings referred to in Article 9(1)(a), the markings set out in paragraphs 2, 3, 4 and 5 of this Article shall be stated.
2. Where micro-nutrients are declared, the words ‘with micro-nutrients’ or the word ‘with’, followed by the name or names and chemical symbols of the micro-nutrients present, shall be given.
3. The declared content of secondary nutrients shall be given as a percentage by mass, as whole numbers or, where necessary, where an appropriate method of analysis exists, to one decimal place.

Where more than one secondary nutrient is present, the order shall be:

CaO and/or Ca, MgO and/or Mg, Na₂O and/or Na, SO₃ and/or S.

The declared content of micro-nutrients shall give the name and symbol of each micro-nutrient, indicating the percentage by mass as specified in sections E.2.2 and E.2.3 of Annex I and according to solubility.

4. The forms and solubility of the nutrients shall also be expressed as a percentage by mass of fertiliser, except where Annex I explicitly provides that this content shall be otherwise expressed.

The number of decimal places shall be one, except for micro-nutrients where it shall be as specified in sections E.2.2 and E.2.3 of Annex I.

5. Unless otherwise stated in Annex I, a declaration of the calcium content shall only be made if it is soluble in water and shall be expressed as a percentage of the fertiliser by mass.

CHAPTER III

Inorganic micro-nutrient fertilisers

Article 22

Scope

This chapter shall apply to inorganic micro-nutrient fertilisers, solid or fluid, with the minimum nutrient content established in sections E.1 and E.2.1 of Annex I.

Article 23

Identification

1. In addition to the compulsory identification markings referred to in Article 9(1)(a) the markings set out in paragraphs 2, 3, 4 and 5 of this Article shall be stated.
2. Where the fertiliser contains more than one micro-nutrient, the type designation ‘mixture of micro-nutrients’ followed by the names of the micro-nutrients present and their chemical symbols, shall be given.

▼B

3. For fertilisers containing only one micro-nutrient (section E.1 of Annex I), the declared micro-nutrient content shall be given as a percentage by mass, in whole numbers or, where necessary, to one decimal place.

4. The forms and solubility of micro-nutrients shall be expressed as a percentage by mass of fertiliser, except where Annex I explicitly provides that this content shall be otherwise expressed.

The number of decimal places for micro-nutrients shall be as specified in section E.2.1 of Annex I.

5. Below the compulsory or optional declarations the following shall be entered on the label and accompanying documents with regard to the products appearing in sections E.1 and E.2.1 of Annex I:

‘To be used only where there is a recognised need. Do not exceed the appropriate dose rates.’

*Article 24***Packaging**

EC fertilisers covered by the provisions of this chapter shall be packaged.

*CHAPTER IV**Ammonium nitrate fertilisers of high nitrogen content**Article 25***Scope**

For the purpose of this chapter, ammonium nitrate fertilisers of high nitrogen content, straight or compound, are ammonium nitrate based products manufactured for use as fertilisers and containing more than 28 % by mass of nitrogen in relation to ammonium nitrate.

This type of fertiliser may contain inorganic or inert substances.

The substances used in the manufacturing of this type of fertiliser must not increase its sensitivity to heat or its tendency to detonate.

*Article 26***Safety measures and controls**

1. The manufacturer shall ensure that straight ammonium nitrate fertilisers of high nitrogen content comply with the provisions of section 1 of Annex III.

2. The checking, analysis and testing for official controls of straight ammonium nitrate fertilisers of high nitrogen content provided for by this chapter shall be carried out in accordance with the methods described in section 3 of Annex III.

▼B

3. To ensure the traceability of ammonium nitrate EC fertilisers of high nitrogen content placed on the market, the manufacturer shall maintain records of the names and addresses of the sites, and of the operators of the sites, at which the fertiliser and its principal components were produced. These records shall be available for inspection by Member States for as long as the fertiliser is being supplied to the market, and for a further period of 2 years after the manufacturer stopped supplying it.

*Article 27***Test of resistance to detonation**

Without prejudice to the measures referred to in Article 26, the manufacturer shall ensure that each type of EC high nitrogen content ammonium nitrate fertiliser placed on the market has passed the test of resistance to detonation described in sections 2, 3 (method 1, point 3) and 4 of Annex III of this Regulation. This test shall be carried out by one of the approved laboratories referred to in Article 30(1) or 33(1). Manufacturers shall submit the results of the test to the competent authority of the Member State concerned at least 5 days before placing the fertiliser on the market, or at least 5 days before the arrival of the fertiliser at the borders of the European Community in the case of imports. Thereafter, the manufacturer shall continue to guarantee that all supplies of the fertiliser placed on the market are capable of passing the abovementioned test.

*Article 28***Packaging**

Ammonium nitrate fertilisers of high nitrogen content shall be made available to the final user only in packaged form.

TITLE III

CONFORMITY ASSESSMENT OF FERTILISERS*Article 29***Control measures**

1. Member States may subject fertilisers marked 'EC fertiliser' to official control measures for the purpose of verifying that they comply with this Regulation.

Member States may charge fees not exceeding the cost of tests needed for such control measures, but this shall not oblige manufacturers to repeat tests or to pay for repeated tests where the first test was made by a laboratory which fulfilled the conditions of Article 30 and where the test showed compliance of the fertiliser in question.

2. Member States shall ensure that sampling and analysis for official controls of EC fertilisers belonging to types of fertilisers listed in Annex I are carried out in accordance with the methods described in Annex III and IV.

▼B

3. Compliance with this Regulation in respect of conformity to types of fertiliser and compliance with the declared nutrient content and/or the declared content expressed as forms and solubilities of such nutrients may be verified at official inspections only by means of sampling and analysis methods established in accordance with Annex III and IV and taking into account the tolerances specified in Annex II.

▼M6

4. The Commission shall adapt and modernise the measuring, sampling and analysis methods and shall, wherever possible, use European Standards. Those measures, designed to amend non-essential elements of this Regulation, shall be adopted in accordance with the regulatory procedure with scrutiny referred to in Article 32(3). The same procedure shall apply to the adoption of implementing rules needed to specify the control measures provided for in this Article and in Articles 8, 26 and 27. Such rules shall in particular address the question of the frequency with which tests need to be repeated, as well as measures that are designed to ensure that the fertiliser put on the market is identical with the fertiliser tested.

▼B*Article 30***Laboratories**

1. Member States shall notify to the Commission the list of those approved laboratories on their territories that are competent to provide the necessary services for checking compliance of EC fertilisers with the requirements of this Regulation. Such laboratories must meet the standards mentioned in section B of Annex V. Such notification shall be made by 11 June 2004 and on the occasion of each subsequent modification.

2. The Commission shall publish the list of approved laboratories in the *Official Journal of the European Union*.

3. Where a Member State has justifiable grounds for believing that an approved laboratory does not meet the standards referred to in paragraph 1, it shall raise this matter in the committee referred to in Article 32. If the committee agrees that the laboratory does not meet the standards, the Commission shall remove the name from the list referred to in paragraph 2.

4. The Commission shall adopt a decision on the matter within 90 days from the receipt of the information in accordance with the procedure referred to in Article 32(2).

5. The Commission shall publish the amended list in the *Official Journal of the European Union*.

▼B

TITLE IV
FINAL PROVISIONS

CHAPTER I
Adaptation of the Annexes

Article 31
New EC fertilisers

▼M6

1. The Commission shall adapt Annex I to include new types of fertilisers.

▼B

2. A manufacturer or its representative which wishes to propose a new type of fertiliser for inclusion in Annex I and is required to compile a technical file for that purpose shall do so by taking into account the technical documents referred to in section A of Annex V.

▼M6

3. The Commission shall adapt the Annexes to take account of technical progress.

4. The measures referred to in paragraphs 1 and 3, designed to amend non-essential elements of this Regulation, shall be adopted in accordance with the regulatory procedure with scrutiny referred to in Article 32(3).

Article 32

Committee procedure

1. The Commission shall be assisted by a Committee.

2. Where reference is made to this paragraph, Articles 5 and 7 of Decision 1999/468/EC shall apply, having regard to the provisions of Article 8 thereof.

The period laid down in Article 5(6) of Decision 1999/468/EC shall be set at three months.

3. Where reference is made to this paragraph, Article 5a(1) to (4) and Article 7 of Decision 1999/468/EC shall apply, having regard to the provisions of Article 8 thereof.

▼B

CHAPTER II
Transitional provisions

Article 33
Competent laboratories

1. Without prejudice to the provisions of Article 30(1), Member States may for a transitional period until 11 December 2007 continue to apply their national provisions for authorising competent laboratories to provide the necessary services for checking compliance of EC fertilisers with the requirements of this Regulation.

▼B

2. Member States shall notify the list of these laboratories to the Commission, giving details of their authorisation scheme. Such notification shall be made by 11 June 2004 and on the occasion of each subsequent modification.

*Article 34***Packaging and labelling**

Notwithstanding Article 35(1), EC fertiliser markings, packagings, labels and accompanying documents provided for by earlier Directives may continue to be used until 11 June 2005.

*CHAPTER III**Final provisions**Article 35***Repealed Directives**

1. Directives 76/116/EEC, 77/535/EEC, 80/876/EEC and 87/94/EEC are hereby repealed.

2. References to the Directives repealed shall be construed as references to this Regulation. In particular, derogations from Article 7 of Directive 76/116/EEC that were granted by the Commission under Article 95(6) of the Treaty shall be construed as derogations from Article 5 of the present Regulation and shall continue to produce their effects notwithstanding the entry into force of this Regulation. Pending the adoption of penalties under Article 36, Member States may continue to apply penalties for infringements of national rules implementing the Directives mentioned in paragraph 1.

*Article 36***Penalties**

The Member States shall lay down the rules on penalties applicable to infringements of the provisions of this Regulation and shall take all measures necessary to ensure that they are implemented. The penalties provided for must be effective, proportionate and dissuasive.

*Article 37***National provisions**

The Member States shall notify the Commission by 11 June 2005 of any national provisions adopted pursuant to Articles 6(1), 6(2), 29(1) and 36 of this Regulation, and shall notify it without delay of any subsequent amendment affecting them.

▼B

Article 38

Entry into force

This Regulation shall enter into force on the twentieth day after its publication in the *Official Journal of the European Union* with the exception of Articles 8 and 26(3), which shall enter into force 11 June 2005.

This Regulation shall be binding in its entirety and directly applicable in all Member States.

**TABLE OF CONTENTS****ANNEX I — List of types of EC fertilisers**

- A. Inorganic straight primary nutrient fertilisers
 - A.1. Nitrogenous fertilisers
 - A.2. Phosphatic fertilisers
 - A.3. Potassic fertilisers
- B. Inorganic compound primary nutrient fertilisers
 - B.1. NPK fertilisers
 - B.2. NP fertilisers
 - B.3. NK fertilisers
 - B.4. PK fertilisers
- C. Inorganic fluid fertilisers
 - C.1. Straight fluid fertilisers
 - C.2. Compound fluid fertilisers
- D. Inorganic secondary nutrient fertilisers
- E. Inorganic micro-nutrient fertilisers
 - E.1. Fertilisers containing only one micro-nutrient
 - E.1.1. Boron
 - E.1.2. Cobalt
 - E.1.3. Copper
 - E.1.4. Iron
 - E.1.5. Manganese
 - E.1.6. Molybdenum
 - E.1.7. Zinc
 - E.2. Minimum micro-nutrient content, percentage weight of fertiliser
 - E.3. List of authorised organic chelating and complexing agents for micro-nutrients

ANNEX II — Tolerances

1. Inorganic straight primary nutrient fertilisers — absolute value in percentage by mass expressed as N, P₂O₅, K₂O, MgO, CL
2. Inorganic compound primary nutrient fertilisers
3. Secondary nutrients in fertilisers
4. Micro-nutrients in fertilisers

ANNEX III — Technical provisions for Ammonium Nitrate Fertilisers of High Nitrogen Content

1. Characteristics of and limits for straight ammonium nitrate fertilisers of high nitrogen content
2. Description of the test of resistance to detonation concerning ammonium nitrate fertilisers of high nitrogen content
3. Methods of checking compliance with the limits specified in annexes III-1 and III-2
4. Determination of resistance to detonation

▼BANNEX IV — **Methods of Sampling and Analysis**

A. Method of sampling for the control of fertilisers

1. Purpose and scope
2. Sampling officers
3. Definitions
4. Apparatus
5. Quantitative requirements
6. Instructions for taking, preparing and Packaging the samples
7. Packaging of final samples
8. Sampling record
9. Destination of samples

B. Methods for the analysis of fertilisers

General observations

General provisions relating to method of analysing fertilisers

- Method 1 — Preparation of the sample for analysis
- Methods 2 — Nitrogen
- Method 2.1 — Determination of ammoniacal nitrogen
- Methods 2.2 — Determination of nitric and ammoniacal nitrogen
- Method 2.2.1 — Determination of nitric and ammoniacal nitrogen according to Ulsch
- Method 2.2.2 — Determination of nitric and ammoniacal nitrogen according to Arnd
- Method 2.2.3 — Determination of nitric and ammoniacal nitrogen according to Devarda
- Method 2.3 — Determination of total nitrogen
- Method 2.3.1 — Determination of the total nitrogen in calcium cyanamide nitrate free
- Method 2.3.2 — Determination of total nitrogen in calcium cyanamide containing nitrates
- Method 2.3.3 — Determination of total nitrogen in urea
- Method 2.4 — Determination of cyanamide nitrogen
- Method 2.5 — Spectrophotometric determination of biuret in urea
- Methods 2.6 — Determination of different forms of nitrogen in the same sample
- Method 2.6.1 — Determination of different forms of nitrogen in the same sample in fertilisers containing nitrogen as nitric, ammoniacal, urea and cyanamide nitrogen
- Method 2.6.2 — Determination of total nitrogen in fertilisers containing nitrogen only as nitric, ammoniacal and urea nitrogen by two different methods
- Method 2.6.3 — Determination of urea condensates using HPLC — Isobutylenediurea and crotonylidenediurea (method A) and methylen-urea oligomers (method B)
- Methods 3 — Phosphorus
- Methods 3.1 — Extractions
- Method 3.1.1 — Extraction of phosphorus soluble in mineral acids

▼B

- Method 3.1.2 — Extraction of the phosphorus soluble in 2 % formic acid (20 g per litre)
- Method 3.1.3 — Extraction of phosphorus soluble in 2 % citric acid (20 g per litre)
- Method 3.1.4 — Extraction of phosphorus which is soluble in neutral ammonium citrate
- Method 3.1.5 — Extraction by alkaline ammonium citrate
- Method 3.1.5.1 — Extraction of soluble phosphorus according to Petermann at 65 °C
- Method 3.1.5.2 — Extraction of the soluble phosphorus according to Petermann at ambient temperature
- Method 3.1.5.3 — Extraction of the phosphorus soluble in Joulie's alkaline ammonium citrate
- Method 3.1.6 — Extraction of water soluble phosphorus
- Method 3.2 — Determination of extracted phosphorus (gravimetric method using quinoline phosphomolybdate)
- Method 4 — Potassium
- Method 4.1 — Determination of the water-soluble potassium content
- Method 5 — Carbon dioxide
- Method 5.1 — Determination of carbon dioxide — Part I: method for solid fertilisers
- Method 6 — Chlorine 116
- Method 6.1 — Determination of chlorides in the absence of organic material
- Methods 7 — Fineness of grinding
- Method 7.1 — Determination of fineness of grinding (dry procedure)
- Method 7.2 — Determination of the fineness of grinding of soft natural phosphates
- Method 8 — Secondary nutrients
- Method 8.1 — Extraction of total calcium, total magnesium, total sodium and total sulphur in the form of sulphates
- Method 8.2 — Extraction of total sulphur present in various forms
- Method 8.3 — Extraction of water-soluble calcium, magnesium, sodium and sulphur (in the form of sulphates)
- Method 8.4 — Extraction of water-soluble sulphur where the sulphur is in various forms
- Method 8.5 — Extraction and determination of elemental sulphur
- Method 8.6 — Manganometric determination of extracted calcium following precipitation in the form of oxalate
- Method 8.7 — Determination of magnesium by atomic absorption spectrometry
- Method 8.8 — Determination of magnesium by complexometry
- Method 8.9 — Determination of the sulfates content using three different methods
- Method 8.10 — Determination of the sodium extracted
- Methods 9 — Micro-nutrients at a concentration of less than or equal to 10 %
- Method 9.1 — Extraction of total micro-nutrients

▼B

- Method 9.2 — Extraction of water-soluble micro-nutrients
- Method 9.3 — Removal of organic compounds from fertiliser extracts
- Method 9.4 — Determination of micro-nutrients in fertiliser extracts by atomic absorption spectrometry (general procedure)
- Method 9.5 — Determination of boron in fertiliser extracts by means of spectrometry with azomethine-H
- Method 9.6 — Determination of cobalt in fertiliser extracts by atomic absorption spectrometry
- Method 9.7 — Determination of copper in fertiliser extracts by atomic absorption spectrometry
- Method 9.8 — Determination of iron in fertiliser extracts by atomic absorption spectrometry
- Method 9.9 — Determination of manganese in fertiliser extracts by atomic absorption spectrometry
- Method 9.10 — Determination of molybdenum in fertiliser extracts by spectrometry of a complex with ammonium thiocyanate
- Method 9.11 — Determination of zinc in fertiliser extracts by atomic absorption spectrometry
- Methods 10 — Micro-nutrients at a concentration greater than 10 %
- Method 10.1 — Extraction of total micro-nutrients
- Method 10.2 — Extraction of water-soluble micro-nutrients
- Method 10.3 — Removal of organic compounds from fertiliser extracts
- Method 10.4 — Determination of micro-nutrients in fertiliser extracts by atomic absorption spectrometry (general procedure)
- Method 10.5 — Determination of boron in fertiliser extracts by means of acidimetric titration
- Method 10.6 — Determination of cobalt in fertiliser extracts by the gravimetric method with 1-nitroso-2-naphthol
- Method 10.7 — Determination of copper in fertiliser extracts by the titrimetric method
- Method 10.8 — Determination of iron in fertiliser extracts by atomic absorption spectrometry
- Method 10.9 — Determination of manganese in fertiliser extracts by titration
- Method 10.10 — Determination of molybdenum in fertiliser extracts by the gravimetric method with 8-hydroxyquinoline
- Method 10.11 — Determination of zinc in fertiliser extracts by atomic absorption spectrometry
- Method 11 — Chelating agents
- Method 11.1 — Determination of the chelated micro-nutrient content and of the chelated fraction of micro-nutrients
- Method 11.2 — Determination of EDTA, HEDTA and DTPA
- Method 11.3 — Determination of iron chelated by o,o EDDHA and o,o EDDHMA
- Method 11.4 — Determination of iron chelated by EDDHSA
- Method 11.5 — Determination of iron chelated by o,p EDDHA

▼B

Methods 12	—	Nitrification and urease inhibitors
Method 12.1	—	Determination of dicyandiamide
Method 12.2	—	Determination of NBPT
Methods 13	—	Heavy metals
Method 13.1	—	Determination of cadmium content

ANNEX V

- A. List of documents to be consulted by manufacturers or their representatives in order to compile a technical file for a new type of fertilisers to be added to annex I of this regulation
- B. Requirements to authorise laboratories that are competent to provide the necessary service for checking compliance of ec fertilisers with the requirements of this regulation and its annexes

ANNEX I

LIST OF TYPES OF EC FERTILISERS

A. Inorganic straight primary nutrient fertilisers

A.1. Nitrogenous fertilisers

No	Type designation	Data on method of production and essential ingredients	Minimum content of nutrients (percentage by weight) Data on the expression of nutrients Other requirements	Other data on the type designation	Nutrient content to be declared Forms and solubilities of the nutrients Other criteria
1	2	3	4	5	6
1(a)	Calcium nitrate (nitrate of lime)	Chemically obtained product containing calcium nitrate as its essential ingredient and possibly ammonium nitrate	15 % N Nitrogen expressed as total nitrogen or as nitric and ammoniacal nitrogen. Maximum content of ammoniacal nitrogen: 1,5 % N		Total nitrogen Additional optional particulars: Nitric nitrogen Ammoniacal nitrogen
1(b)	Calcium magnesium nitrate (nitrate of lime and magnesium)	Chemically obtained product containing calcium nitrate and magnesium nitrate as essential ingredients	13 % N Nitrogen expressed as nitric nitrogen. Minimum content of magnesium in the form of water-soluble salts expressed as magnesium oxide: 5 % MgO		Nitric nitrogen Water-soluble magnesium oxide
1(c)	Magnesium nitrate	Chemically obtained product containing as its essential ingredient hexahydrated magnesium nitrate	10 % N Nitrogen expressed as nitric nitrogen 14 % MgO Magnesium expressed as water-soluble magnesium oxide	When marketed in the form of crystals as note 'in crystallised form' may be added	Nitric nitrogen Water-soluble magnesium oxide
2(a)	Sodium nitrate (nitrate of soda)	Chemically obtained product containing sodium nitrate as its essential ingredient	15 % N Nitrogen expressed as nitric nitrogen		Nitric nitrogen
2(b)	Chile nitrate	Product prepared from caliche, containing sodium nitrate as its essential ingredient	15 % N Nitrogen expressed as nitric nitrogen		Nitric nitrogen

▼B

1	2	3	4	5	6
3(a)	Calcium cyanamide	Chemically obtained product containing calcium cyanamide as its essential ingredient, calcium oxide and possibly small quantities of ammonium salts and urea	18 % N Nitrogen expressed as total nitrogen, at least 75 % of the nitrogen declared being bound in the form of cyanamide		Total nitrogen
3(b)	Nitrogenous calcium cyanamide	Chemically obtained product containing calcium cyanamide as its essential ingredient, and calcium oxide and possibly small quantities of ammonium salts and urea, plus added nitrate	18 % N Nitrogen expressed as total nitrogen, at least 75 % of the non-nitric nitrogen declared being bound in the form of cyanamide. Nitric nitrogen content: — minimum: 1 % N — maximum: 3 % N		Total nitrogen Nitric nitrogen
▼ <u>M5</u> 4	Sulphate of ammonia	Chemically obtained product containing ammonium sulphate as its essential ingredient, possibly with up to 15 % calcium nitrate (nitrate of lime).	19,7 % N Nitrogen expressed as total nitrogen. Maximum content of nitric nitrogen 2,2 % N if calcium nitrate (nitrate of lime) is added.	When marketed in the form of a combination of ammonium sulphate and calcium nitrate (nitrate of lime), the designation must include 'with up to 15 % calcium nitrate (nitrate of lime)'.	Ammoniacal nitrogen. Total nitrogen if calcium nitrate (nitrate of lime) is added
▼ <u>B</u> 5	Ammonium nitrate or calcium ammonium nitrate	Chemically obtained product containing ammonium nitrate as its essential ingredient, which may contain fillers such as ground limestone, calcium sulphate, ground dolomite, magnesium sulphate, kieserite	20 % N Nitrogen expressed as nitric nitrogen and ammoniacal nitrogen, each of these two forms of nitrogen accounting for about half the nitrogen present. See Annexes III.1 and III.2 of this regulation, if required.	The designation 'calcium ammonium nitrate' is exclusively reserved for a fertiliser containing only calcium carbonate (for instance limestone) and/or magnesium carbonate and calcium carbonate (for instance dolomite) in addition to ammonium nitrate. The minimum content of these carbonates must be 20 % and their purity level at least 90 %	Total nitrogen Nitric nitrogen Ammoniacal nitrogen

▼B

1	2	3	4	5	6
6	Ammonium sulphate-nitrate	Chemically obtained product containing as essential ingredients ammonium nitrate and ammonium sulphate	25 % N Nitrogen expressed as ammoniacal and nitric nitrogen. Minimum nitric nitrogen content: 5 %		Total nitrogen Ammoniacal nitrogen Nitric nitrogen
7	Magnesium sulphonitrate	Chemically obtained product containing ammonium nitrate, ammonium sulphate and magnesium sulphate as essential ingredients	19 % N Nitrogen expressed as ammoniacal and nitric nitrogen. Minimum nitric nitrogen content: 6 % N 5 % MgO Magnesium in the form of water-soluble salts expressed as magnesium oxide		Total nitrogen Ammoniacal nitrogen Nitric nitrogen Water-soluble magnesium oxide
8	Magnesium ammonium nitrate	Chemically obtained product containing ammonium nitrates and magnesium compound salts (dolomite magnesium carbonate and/or magnesium sulphate) as essential ingredients	19 % N Nitrogen expressed as ammoniacal nitrogen and nitric nitrogen. Minimum nitric nitrogen content 6 % N 5 % MgO Magnesium expressed as total magnesium oxide		Total nitrogen Ammoniacal nitrogen Nitric nitrogen Total magnesium oxide and possibly, water-soluble magnesium oxide
9	Urea	Chemically obtained product containing carbonyl diamide (carbamide) as its essential ingredient	44 % N Total ureic nitrogen (including biuret). Maximum biuret content: 1,2 %		Total nitrogen, expressed as ureic nitrogen
10	Crotonylidene diurea	Product obtained by reaction of urea with crotonaldehyde Monomeric compound	28 % N Nitrogen expressed as total nitrogen At least 25 % N from the crotonylidene diurea Maximum ureic nitrogen content: 3 %		Total nitrogen Ureic nitrogen where this is at least 1 % by weight Nitrogen from crotonylidene diurea

▼B

1	2	3	4	5	6
11	Isobutylidene diurea	Product obtained by reaction of urea with isobutyraldehyde Monomeric compound Monomeric compound	28 % N Nitrogen expressed as total nitrogen At least 25 % N from isobutylidene diurea Maximum ureic nitrogen content: 3 %		Total nitrogen Ureic nitrogen where this is at least 1 % by weight Nitrogen from isobutylidene diurea
12	Urea formaldehyde	Product obtained by reaction of urea with formaldehyde and containing as its essential ingredients molecules of urea formaldehyde Polymeric compound	36 % N total nitrogen Nitrogen expressed as total nitrogen At least 3/5 of the declared total nitrogen content must be soluble in hot water At least 31 % N from urea formaldehyde Maximum ureic nitrogen content: 5 %		Total nitrogen Ureic nitrogen where this is at least 1 % by weight Nitrogen from formaldehyde urea that is soluble in cold water Nitrogen from formaldehyde urea that is only soluble in hot water
13	Nitrogenous fertiliser containing crotonylidene diurea	Product obtained chemically containing crotonylidene diurea and a straight nitrogen fertiliser [List A-1, excluding products 3(a), 3(b) and 5]	18 % N expressed as total nitrogen At least 3 % nitrogen in ammoniacal and/or nitric and/or ureic form At least 1/3 of the declared total nitrogen content must be derived from crotonylidene diurea Maximum biuret content: (ureic N + crotonylidene diurea N) × 0,026		Total nitrogen For each form amounting to at least 1 %: — nitric nitrogen — ammoniacal nitrogen — ureic nitrogen Nitrogen from crotonylidene diurea
14	Nitrogenous fertiliser containing isobutylidene diurea	Product obtained chemically containing isobutylidene diurea and a straight nitrogenous fertiliser [List A-1, excluding products 3(a), 3(b) and 5]	18 % N expressed as total nitrogen At least 3 % nitrogen in ammoniacal and/or nitric and/or ureic form At least 1/3 of the declared total nitrogen content must derive from isobutylidene diurea Maximum biuret content: (Ureic N + isobutylidene diurea N) × 0,026		Total nitrogen For each form amounting to at least 1 %: — nitric nitrogen — ammoniacal nitrogen — ureic nitrogen Nitrogen from isobutylidene diurea

▼ **B**

1	2	3	4	5	6
15	Nitrogenous fertiliser containing urea formaldehyde	Product obtained chemically containing urea formaldehyde and a straight nitrogenous fertiliser [List A-1, excluding products 3(a), 3(b) and 5]	18 % N expressed as total nitrogen At least 3 % nitrogen in ammoniacal and/or nitric and/or ureic form At least 1/3 of the declared total nitrogen content must derive from urea formaldehyde The nitrogen from the urea formaldehyde must contain at least 3/5 nitrogen that is soluble in hot water Maximum biuret content: (Ureic N + urea formaldehyde) × 0,026		Total nitrogen For each form amounting to at least 1 %: — nitric nitrogen — ammoniacal nitrogen — ureic nitrogen Nitrogen from urea formaldehyde Nitrogen from urea formaldehyde that is soluble in cold water Nitrogen from urea formaldehyde that is only soluble in hot water

▼ **M5**

--	--	--	--	--	--

▼ **B**

► M5 16 ◀	Urea-ammonium sulphate	Product obtained chemically from urea and ammonium sulphate	30 % N Nitrogen expressed as ammoniacal and ureic nitrogen Minimum ammoniacal nitrogen content: 4 % Minimum sulphur content expressed as sulphur trioxide: 12 % Maximum biuret content: 0,9 %		Total nitrogen Ammoniacal nitrogen Ureic nitrogen Water-soluble sulphur trioxide
------------------	------------------------	---	---	--	---

► **M5** ——— ◀

▼B

A.2. Phosphatic fertilisers

Where a particle size criterion is prescribed for the basic constituent materials of fertilisers sold in granular form (fertilisers 1, 3, 4, 5, 6 and 7), it will be established by an appropriate analytical method.

No	Type designation	Data on method of production and essential ingredients	Minimum content of nutrients (percentage by weight) Data on the expression of nutrients Other requirements	Other data on the type designation	Nutrient content to be declared Forms and solubilities of the nutrients Other criteria
1	2	3	4	5	6
1	Basic slag: — Thomas phosphates — Thomas slag	Product obtained in iron-smelting by treatment of the phosphorus melts and containing calcium silicophosphates as its essential ingredients	12 % P ₂ O ₅ Phosphorus expressed as phosphorus pentoxide soluble in mineral acids, at least 75 % of the declared content of phosphorus pentoxide being soluble in 2 % citric acid or P ₂ O ₅ Phosphorus expressed as phosphorus pentoxide soluble in 2 % citric acid Particle size: — at least 75 % able to pass through a sieve with a mesh of 0,160 mm — at least 96 % able to pass through a sieve with a mesh of 0,630 mm		Total phosphorus pentoxide (soluble in mineral acids) 75 % of which (to be indicated as % by weight) is soluble in 2 % citric acid (for marketing in France, Italy, Spain, Portugal, Greece ► M1 , Czech Republic, Estonia, Cyprus, Latvia, Lithuania, Hungary, Malta, Poland, Slovenia, Slovakia, ◀ ► M3 Bulgaria and Romania ◀) Total phosphorus pentoxide (soluble in mineral acids) and phosphorus pentoxide soluble in 2 % citric acid (for marketing in the United Kingdom) Phosphorus pentoxide soluble in 2 % citric acid (for marketing in Germany, Belgium, Denmark, Ireland, Luxembourg, the Netherlands and Austria)
2(a)	Single superphosphate	Product obtained by reaction of ground mineral phosphate with sulphuric acid and containing monocalcium phosphate as an essential ingredient as well as calcium sulphate	16 % P ₂ O ₅ Phosphorus expressed as P ₂ O ₅ soluble in neutral ammonium citrate, at least 93 % of the declared content of P ₂ O ₅ being water-soluble Test sample: 1 g		Phosphorus pentoxide soluble in neutral ammonium citrate Water-soluble phosphorus pentoxide
2(b)	Concentrated superphosphate	Product obtained by reaction of ground mineral phosphate with sulphuric acid and phosphoric acid and containing monocalcium phosphate as an essential ingredient as well as calcium sulphate	25 % P ₂ O ₅ Phosphorus expressed as P ₂ O ₅ soluble in neutral ammonium citrate, at least 93 % of the declared content of P ₂ O ₅ being water-soluble Test sample: 1 g		Phosphorus pentoxide soluble in neutral ammonium citrate Water-soluble phosphorus pentoxide

▼ M2

1	2	3	4	5	6
2(c)	Triple superphosphate	Product obtained by reaction of ground mineral phosphate with phosphoric acid and containing monocalcium phosphate as its essential ingredient	38 % P ₂ O ₅ Phosphorus expressed as P ₂ O ₅ soluble in neutral ammonium citrate, at least 85 % of the declared content of P ₂ O ₅ being water-soluble Test sample: 3 g		Phosphorus pentoxide soluble in neutral ammonium citrate Water-soluble phosphorus pentoxide

▼ B

3	Partially solubilised rock phosphate	Product obtained by partial solubilisation of ground rock phosphate with sulphuric acid or phosphoric acid and containing as essential ingredients monocalcium phosphate, tricalcium phosphate and calcium sulphate	20 % P ₂ O ₅ Phosphorus expressed as P ₂ O ₅ soluble in mineral acids, at least 40 % of the declared content of P ₂ O ₅ being water-soluble Particle size: — at least 90 % able to pass through a sieve with a mesh of 0,160 mm — at least 98 % able to pass through a sieve with a mesh of 0,630 mm		Total phosphorus pentoxide (soluble in mineral acids) Phosphorus pentoxide soluble in water
---	--------------------------------------	---	--	--	--

▼ M7

3(a)	Partially solubilised rock phosphate with magnesium	Product obtained by partial solubilisation of ground rock phosphate with sulphuric acid or phosphoric acid with the addition of magnesium sulphate or magnesium oxide, and containing as essential ingredients monocalcium phosphate, tricalcium phosphate, calcium sulphate and magnesium sulphate	16 % P ₂ O ₅ 6 % MgO Phosphorus expressed as P ₂ O ₅ soluble in mineral acids, at least 40 % of the declared content of P ₂ O ₅ being water-soluble Particle size: — at least 90 % able to pass through a sieve with a mesh of 0,160 mm — at least 98 % able to pass through a sieve with a mesh of 0,630 mm		Total phosphorus pentoxide (soluble in mineral acids) Phosphorus pentoxide soluble in water Total magnesium oxide Water-soluble magnesium oxide
------	---	---	---	--	--

▼ B

4	Dicalcium phosphate	Product obtained by precipitation of solubilised phosphoric acid from mineral phosphates or bones, and containing dicalcium phosphate dihydrate as its essential ingredient	38 % P ₂ O ₅ Phosphorus expressed as P ₂ O ₅ soluble in alkaline ammonium citrate (Petermann) Particle size: — at least 90 % able to pass through a sieve with a mesh of 0,160 mm — at least 98 % able to pass through a sieve with a mesh of 0,630 mm		Phosphorus pentoxide soluble in alkaline ammonium citrate
---	---------------------	---	--	--	---

▼B

1	2	3	4	5	6
5	Calcined phosphate	Product obtained by heat treatment of ground rock phosphate with alkaline compounds and silicic acid, and containing alkaline calcium phosphate and calcium silicate as essential ingredients	25 % P ₂ O ₅ Phosphorus expressed as P ₂ O ₅ soluble in alkaline ammonium citrate (Petermann) Particle size: — at least 75 % able to pass through a sieve with a mesh of 0,160 mm — at least 96 % able to pass through a sieve with a mesh of 0,630 mm		Phosphorus pentoxide soluble in alkaline ammonium citrate
6	Aluminium-calcium phosphate	Product obtained in amorphous form by heat treatment and grinding, containing aluminium and calcium phosphates as essential ingredients	30 % P ₂ O ₅ Phosphorus expressed as P ₂ O ₅ soluble in mineral acids, at least 75 % of the declared content of P ₂ O ₅ being soluble in alkaline ammonium citrate (Joulie) Particle size: — at least 90 % able to pass through a sieve with a mesh of 0,160 mm — at least 98 % able to pass through a sieve with a mesh of 0,630 mm		Total phosphorus pentoxide (soluble in mineral acids) Phosphorus pentoxide soluble in alkaline ammonium citrate
7	Soft ground rock phosphate	Product obtained by grinding soft mineral phosphates and containing tricalcium phosphate and calcium carbonate as essential ingredients	25 % P ₂ O ₅ Phosphorus expressed as P ₂ O ₅ soluble in mineral acids, at least 55 % of the declared content of P ₂ O ₅ being soluble in 2 % formic acid Particle size: — at least 90 % able to pass through a sieve with a mesh of 0,063 mm — at least 99 % able to pass through a sieve with a mesh of 0,125 mm		Total phosphorus pentoxide (soluble in mineral acids) Phosphorus pentoxide soluble in 2 % formic acid Percentage by weight of material able to pass through a sieve with a mesh of 0,063 mm

▼B

A.3. Potassic fertilisers

No	Type designation	Data on method of production and essential ingredients	Minimum content of nutrients (percentage by weight) Data on the expression of nutrients Other requirements	Other data on the type designation	Nutrient content to be declared Forms and solubilities of the nutrients Other criteria
1	2	3	4	5	6
1	Kainit	Product obtained from crude potassium salts	10 % K ₂ O Potassium expressed as water-soluble K ₂ O 5 % MgO Magnesium in the form of water-soluble salts, expressed as magnesium oxide	Usual trade names may be added	Water-soluble potassium oxide Water-soluble magnesium oxide
2	Enriched kainit salt	Product obtained from crude potassium salts enriched by blending with potassium chloride	18 % K ₂ O Potassium expressed as water-soluble K ₂ O	Usual trade names may be added	Water-soluble potassium oxide Optional mention of the water-soluble magnesium oxide content where higher than 5 % MgO
3	Muriate of potash	Product obtained from crude potassium salts and containing potassium chloride as its essential ingredient	37 % K ₂ O Potassium expressed as water-soluble K ₂ O	Usual trade names may be added	Water-soluble potassium oxide
4	Potassium chloride containing magnesium salts	Product obtained from crude potassium salts with added magnesium salts and containing potassium chloride and magnesium salts as essential ingredients	37 % K ₂ O Potassium expressed as water-soluble K ₂ O 5 % MgO Magnesium in the form of water-soluble salts, expressed as magnesium oxide		Water-soluble potassium oxide Water-soluble magnesium oxide

▼B

1	2	3	4	5	6
5	Sulphate of potash	Product obtained chemically from potassium salts and containing potassium sulphate as its essential ingredient	47 % K ₂ O Potassium expressed as water-soluble K ₂ O Maximum chloride content: 3 % Cl		Water-soluble potassium oxide Optional mention of the chloride content
6	Sulphate of potash containing magnesium salt	Product obtained chemically from potassium salts, possibly with addition of magnesium salts, and containing potassium sulphate and magnesium sulphate as essential ingredients	22 % K ₂ O Potassium expressed as water-soluble K ₂ O 8 % MgO Magnesium in the form of water-soluble salts, expressed as magnesium oxide Maximum chloride content: 3 % Cl	Usual trade names may be added	Water-soluble potassium oxide Water-soluble magnesium oxide Optional mention of the chloride content
7	Kieserite with potassium sulphate	Product obtained from Kieserite with potassium sulphate added	8 % MgO Magnesium expressed as water-soluble MgO 6 % K ₂ O Potassium expressed as water-soluble K ₂ O Total MgO + K ₂ O: 20 % Maximum chloride content: 3 % Cl	Usual trade names may be added	Water-soluble magnesium oxide Water-soluble potassium oxide Optional mention of the chloride content

B. Inorganic compound primary nutrient fertilisers

B.1. NPK fertilisers

B.1.1.	Type designation:	NPK fertilisers.
	Data on method of production:	Product obtained chemically or by blending, without addition of organic nutrients of animal or vegetable origin.
	Minimum content of nutrients (percentage by weight):	— Total: 20 % (N + P ₂ O ₅ + K ₂ O); — For each of the nutrients: 3 % N, 5 % P ₂ O ₅ , 5 % K ₂ O.

▼B

Forms, solubilities and nutrient content to be declared as specified in columns 4, 5 and 6 Particle size			Data for identification of the fertilisers Other requirements		
N	P ₂ O ₅	K ₂ O	N	P ₂ O ₅	K ₂ O
1	2	3	4	5	6
(1) Total nitrogen (2) Nitric nitrogen (3) Ammoniacal nitrogen (4) Ureic nitrogen (5) Cyanamide nitrogen	(1) Water-soluble P ₂ O ₅ (2) P ₂ O ₅ soluble in neutral ammonium citrate (3) P ₂ O ₅ soluble in neutral ammonium citrate and in water (4) P ₂ O ₅ soluble in mineral acids only (5) P ₂ O ₅ soluble in alkaline ammonium citrate (Petermann) (6a) P ₂ O ₅ soluble in mineral acids, of which at least 75 % of the declared P ₂ O ₅ content is soluble in 2 % citric acid (6b) P ₂ O ₅ soluble in 2 % citric acid (7) P ₂ O ₅ soluble in mineral acids, of which at least 75 % of the declared P ₂ O ₅ content is soluble in alkaline ammonium citrate (Joulie) (8) P ₂ O ₅ soluble in mineral acids, of which at least 55 % of the declared P ₂ O ₅ content is soluble in 2 % formic acid	Water soluble K ₂ O	(1) Total nitrogen (2) If any of the forms of nitrogen (2) to (5) amounts to at least 1 % by weight, it must be declared (3) If above 28 %, see Annex III.2	1. An NPK fertiliser free from Thomas slag, calcined phosphate, aluminium-calcium phosphate, partially solubilised rock phosphate and soft ground rock phosphate must be declared in accordance with solubilities (1), (2) or (3): <ul style="list-style-type: none"> — when the water-soluble P₂O₅ does not amount to 2 %, solubility (2) only shall be declared; — when the water-soluble P₂O₅ is at least 2 %, solubility (3) shall be declared, and the water-soluble P₂O₅ content must be indicated [solubility (1)]. The P ₂ O ₅ content soluble in mineral acids only must not exceed 2 %. For this type 1, the test sample for determining solubilities (2) and (3) shall be 1 g. 2 (a) An NPK fertiliser containing soft ground rock phosphate or partially solubilised rock phosphate must be free from Thomas slag, calcined phosphate and aluminium-calcium phosphate. It shall be declared in accordance with solubilities (1), (3) and (4) This type of fertiliser must contain: <ul style="list-style-type: none"> — at least 2 % P₂O₅ soluble in mineral acids only [solubility (4)]; 	(1) Water-soluble potassium oxide (2) The indication 'low in chloride' is linked to a maximum content of 2 % Cl (3) Chloride content may be declared

▼B

1	2	3	4	5	6
				<ul style="list-style-type: none"> — at least 5 % P₂O₅ soluble in water and neutral ammonium citrate [solubility (3)]; — at least 2,5 % water-soluble P₂O₅ [solubility (1)]. <p>This type of fertiliser must be marketed under the designation ‘NPK fertiliser containing soft ground rock phosphate’ or ‘NPK fertiliser containing partially solubilised rock phosphate’. For this type 2(a), the test sample for determining solubility (3) shall be 3 g.</p>	
<p>Particle size of the basic phosphatic ingredients</p> <p>Thomas slag:</p> <p>Aluminium-calcium phosphate:</p> <p>Calcined phosphate:</p> <p>Soft ground rock phosphate:</p> <p>Partially solubilised rock phosphate:</p>	<p>at least 75 % able to pass through a sieve with a mesh of 0,160 mm</p> <p>at least 90 % able to pass through a sieve with a mesh of 0,160 mm</p> <p>at least 75 % able to pass through a sieve with a mesh of 0,160 mm</p> <p>at least 90 % able to pass through a sieve with a mesh of 0,063 mm</p> <p>at least 90 % able to pass through a sieve with a mesh of 0,160 mm</p>			<p>2 (b) An NPK fertiliser containing aluminium-calcium phosphate must be free from Thomas slag, calcined phosphate, soft ground rock phosphate and partially solubilised rock phosphate.</p> <p>It shall be declared in accordance with solubilities (1) and (7), the latter applying after deduction of the solubility in water.</p> <p>This type of fertiliser must contain:</p> <ul style="list-style-type: none"> — at least 2 % of water-soluble P₂O₅ [solubility (1)]; — at least 5 % of P₂O₅ according to solubility (7). <p>This type of fertiliser must be marketed under the designation ‘NPK fertiliser containing aluminium-calcium phosphate’.</p> <p>3. In the case of NPK fertilisers containing only one of the following types of phosphatic fertiliser: Thomas slag, calcined phosphate, aluminium-calcium phosphate, soft ground rock</p>	

▼B

1	2	3	4	5	6
				<p>phosphate, the type designation must be followed by an indication of the phosphate ingredient.</p> <p>The declaration of the solubility of the P₂O₅ must be given in accordance with the following solubilities:</p> <ul style="list-style-type: none"> — for fertilisers based on Thomas slag: solubility (6a) (France, Italy, Spain, Portugal, Greece ►M1, Czech Republic, Estonia, Cyprus, Latvia, Lithuania, Hungary, Malta, Poland, Slovenia, Slovakia, ◀►M3 Bulgaria, Romania ◀), (6b) (Germany, Belgium, Denmark, Ireland, Luxembourg, Netherlands, United Kingdom and Austria); — for fertilisers based on calcined phosphate: solubility (5); — for fertilisers based on aluminium-calcium phosphate: solubility (7); — for fertilisers based on soft ground rock phosphate: solubility (8). 	

B.1.2.	Type designation:	NPK fertiliser containing crotonylidene diurea or isobutylidene diurea or urea formaldehyde (as appropriate).
	Data on method of production:	Product obtained chemically without addition of organic nutrients of animal or vegetable origin and containing crotonylidene diurea or isobutylidene diurea or urea formaldehyde.
	Minimum content of nutrients (percentage by weight):	<ul style="list-style-type: none"> — Total: 20 % (N + P₂O₅ + K₂O); — For each of the nutrients: <ul style="list-style-type: none"> — 5 % N. At least ¼ of the declared content of total nitrogen must derive from nitrogen form (5) or (6) or (7). At least 3/5 of the declared nitrogen content (7) must be soluble in hot water, — 5 % P₂O₅, — 5 % K₂O.

▼B

Forms, solubilities and nutrient content to be declared as specified in columns 4, 5 and 6 Particle size			Data for identification of the fertilisers Other requirements		
N	P ₂ O ₅	K ₂ O	N	P ₂ O ₅	K ₂ O
1	2	3	4	5	6
(1) Total nitrogen (2) Nitric nitrogen (3) Ammoniacal nitrogen (4) Ureic nitrogen (5) Nitrogen from crotonylidene diurea (6) Nitrogen from isobutylidene diurea (7) Nitrogen from urea formaldehyde (8) Nitrogen from urea formaldehyde that is only soluble in hot water (9) Nitrogen from urea formaldehyde that is soluble in cold water	(1) Water-soluble P ₂ O ₅ (2) P ₂ O ₅ soluble in neutral ammonium citrate (3) P ₂ O ₅ soluble in neutral ammonium citrate and in water	Water-soluble K ₂ O	(1) Total nitrogen (2) If any of the forms of nitrogen (2) to (4) amounts to at least 1 % by weight, it must be declared (3) One of the forms of nitrogen (5) to (7) (as appropriate). Nitrogen form (7) must be declared in the form of nitrogen (8) and (9)	An NPK fertiliser free from Thomas slag, calcined phosphate, aluminium-calcium phosphate, partially solubilised rock phosphate and rock phosphate must be declared in accordance with solubilities (1), (2) or (3): — when the water-soluble P ₂ O ₅ does not amount to 2 %, solubility (2) only shall be declared, — when the water-soluble P ₂ O ₅ is at least 2 %, solubility (3) shall be declared, and the water-soluble P ₂ O ₅ content must be indicated [solubility (1)]. The P ₂ O ₅ content soluble in mineral acids only must not exceed 2 %. The test sample for determining solubilities (2) and (3) shall be 1 g.	(1) Water-soluble potassium oxide (2) The indication 'low in chloride' is linked to a maximum content of 2 % Cl (3) Chloride content may be declared

B.2. NP fertilisers

B.2.1.	Type designation:	NP fertilisers.
	Data on method of production:	Product obtained chemically or by blending without addition of organic nutrients of animal or vegetable origin.
	Minimum content of nutrients (percentage by weight):	— Total: 18 % (N + P ₂ O ₅); — For each of the nutrients: 3 % N, 5 % P ₂ O ₅ .

▼B

Forms, solubilities and nutrient content to be declared as specified in columns 4, 5 and 6 Particle size			Data for identification of the fertilisers Other requirements		
N	P ₂ O ₅	K ₂ O	N	P ₂ O ₅	K ₂ O
1	2	3	4	5	6
(1) Total nitrogen (2) Nitric nitrogen (3) Ammoniacal nitrogen (4) Ureic nitrogen (5) Cyanamide nitrogen	(1) Water-soluble P ₂ O ₅ (2) P ₂ O ₅ soluble in neutral ammonium citrate (3) P ₂ O ₅ soluble in neutral ammonium citrate and in water (4) P ₂ O ₅ soluble in mineral acids only (5) P ₂ O ₅ soluble in alkaline ammonium citrate (Petermann) (6a) P ₂ O ₅ soluble in mineral acids, of which at least 75 % of the declared P ₂ O ₅ content is soluble in 2 % citric acid (6b) P ₂ O ₅ soluble in 2 % citric acid (7) P ₂ O ₅ soluble in mineral acids of which at least 75 % of the declared P ₂ O ₅ content is soluble in alkaline ammonium citrate (Joulie) (8) P ₂ O ₅ soluble in mineral acids of which at least 55 % of the declared P ₂ O ₅ content is soluble in 2 % formic acid		(1) Total nitrogen (2) If any of the forms of nitrogen (2) to (5) amounts to at least 1 % by weight, it must be declared	1. An NP fertiliser free from Thomas slag, calcined phosphate, aluminium-calcium phosphate, partially solubilised rock phosphate and soft ground rock phosphate must be declared in accordance with solubilities (1), (2) or (3): <ul style="list-style-type: none"> — when the water-soluble P₂O₅ does not amount to 2 %, solubility (2) only shall be declared; — when the water-soluble P₂O₅ is at least 2 %, solubility (3) shall be declared, and the water-soluble P₂O₅ content must be indicated [solubility (1)]. The P ₂ O ₅ content soluble in mineral acids only must not exceed 2 %. For this type 1, the test sample for determining solubilities (2) and (3) shall be 1 g. 2 (a) A NP fertiliser containing soft ground rock phosphate or partially solubilised rock phosphate must be free from Thomas slag, calcined phosphate and aluminium-calcium phosphate. It shall be declared in accordance with solubilities (1), (3) and (4). This type of fertiliser must contain: <ul style="list-style-type: none"> — at least 2 % P₂O₅ soluble in mineral acids only [solubility (4)]; 	

▼B

1	2	3	4	5	6
<p>Particle size of the basic phosphatic ingredients:</p> <p>Thomas slag</p> <p>Aluminium-calcium phosphate</p> <p>Calcined phosphate</p> <p>Soft ground rock phosphate</p> <p>Partially solubilised rock phosphate</p>	<p>at least 75 % able to pass through a sieve with a mesh of 0,160 mm</p> <p>at least 90 % able to pass through a sieve with a mesh of 0,160 mm</p> <p>at least 75 % able to pass through a sieve with a mesh of 0,160 mm</p> <p>at least 90 % able to pass through a sieve with a mesh of 0,063 mm</p> <p>at least 90 % able to pass through a sieve with a mesh of 0,160 mm</p>			<p>— at least 5 % P₂O₅ soluble in water and neutral ammonium citrate [solubility (3)];</p> <p>— at least 2,5 % water soluble P₂O₅ [solubility (1)].</p> <p>This type of fertiliser must be marketed under the designation ‘NP fertiliser containing soft ground rock phosphate’ or ‘NP fertiliser containing partially solubilised rock phosphate’.</p> <p>For this type 2(a), the test sample for determining solubility (3) shall be 3 g.</p> <p>2 (b) A NP fertiliser containing aluminium-calcium phosphate, must be free from Thomas slag, calcined phosphate, soft ground rock phosphate and partially solubilised rock phosphate.</p> <p>It shall be declared in accordance with solubilities (1) and (7), the latter applying after deduction of the solubility in water.</p> <p>This type of fertiliser must contain:</p> <p>— at least 2 % water-soluble P₂O₅ [solubility (1)];</p> <p>— at least 5 % P₂O₅ according to solubility (7).</p> <p>This type of fertiliser must be marketed under the designation ‘NP fertiliser containing aluminium-calcium phosphate’.</p> <p>3. In the case of NP fertilisers containing only one of the following types of phosphatic fertiliser: Thomas slag, calcined phosphate, aluminium-calcium phosphate, soft ground rock</p>	

▼B

1	2	3	4	5	6
				<p>phosphate, the type designation must be followed by an indication of the phosphate ingredient.</p> <p>The declaration of the solubility of the P₂O₅ must be given in accordance with the following solubilities:</p> <ul style="list-style-type: none"> — for fertilisers based on Thomas slag: solubility (6a) (France, Italy, Spain, Portugal, Greece ► M1, Czech Republic, Estonia, Cyprus, Latvia, Lithuania, Hungary, Malta, Poland, Slovenia, Slovakia, ◄► M3 Bulgaria, Romania ◄), (6b) (Germany, Belgium, Denmark, Ireland, Luxembourg, Netherlands, United Kingdom and Austria); — for fertilisers based on calcined phosphate: solubility (5); — for fertilisers based on aluminium-calcium phosphate: solubility (7); — for fertilisers based on soft ground rock phosphate: solubility (8). 	

B.2.2.	Type designation:	NP fertiliser containing crotonylidene diurea or isobutylidene diurea or urea formaldehyde (as appropriate)
	Data on method of production:	Product obtained chemically without addition of organic nutrients of animal or vegetable origin and containing crotonylidene diurea or isobutylidene diurea or urea formaldehyde
	Minimum content of nutrients (percentage by weight):	<ul style="list-style-type: none"> — Total: 18 % (N + P₂O₅); — For each of the nutrients: <ul style="list-style-type: none"> — 5 % N. At least ¼ of the declared content of total nitrogen must derive from nitrogen form (5) or (6) or (7). At least 3/5 of the declared nitrogen content (7) must be soluble in hot water, — 5 % P₂O₅.

▼B

Forms, solubilities and nutrient content to be declared as specified in columns 4, 5 and 6 Particle size			Data for identification of the fertilisers Other requirements		
N	P ₂ O ₅	K ₂ O	N	P ₂ O ₅	K ₂ O
1	2	3	4	5	6
(1) Total nitrogen (2) Nitric nitrogen (3) Ammoniacal nitrogen (4) Ureic nitrogen (5) Nitrogen from crotonylidene diurea (6) Nitrogen from isobutylidene diurea (7) Nitrogen from urea formaldehyde (8) Nitrogen from urea formaldehyde that is only soluble in hot water (9) Nitrogen from urea formaldehyde that is soluble in cold water	(1) Water-soluble P ₂ O ₅ (2) P ₂ O ₅ soluble in neutral ammonium citrate (3) P ₂ O ₅ soluble in neutral ammonium citrate and in water		(1) Total nitrogen (2) If any of the forms of nitrogen (2) to (4) amounts to at least 1 % by weight, it must be declared (3) One of the forms of nitrogen (5) to (7) (as appropriate). Nitrogen form (7) must be declared in the form of nitrogen (8) and (9)	An NP fertiliser free of Thomas slag, calcined phosphate, aluminium-calcium phosphate, partially solubilised rock phosphate and rock phosphate must be declared in accordance with solubilities (1), (2) or (3): — when the water-soluble P ₂ O ₅ does not amount to 2 %, solubility (2) only shall be declared; — when the water-soluble P ₂ O ₅ is at least 2 %, solubility (3) shall be declared, and the water-soluble P ₂ O ₅ content must be indicated [solubility (1)]. The P ₂ O ₅ content soluble in mineral acids only must not exceed 2 %. The test sample for determining solubilities (2) and (3) shall be 1 g.	

B.3. NK fertilisers

B.3.1.	Type designation:	NK fertilisers.
	Data on method of production:	Product obtained chemically or by blending, without addition of organic nutrients of animal or vegetable origin.
	Minimum content of nutrients (percentage by weight):	— Total: 18 % (N + K ₂ O); — For each of the nutrients: 3 % N, 5 % K ₂ O.

▼B

Forms, solubilities and nutrient content to be declared as specified in columns 4, 5 and 6 Particle size			Data for identification of the fertilisers Other requirements		
N	P ₂ O ₅	K ₂ O	N	P ₂ O ₅	K ₂ O
1	2	3	4	5	6
(1) Total nitrogen (2) Nitric nitrogen (3) Ammoniacal nitrogen (4) Ureic nitrogen (5) Cyanamide nitrogen		Water-soluble K ₂ O	(1) Total nitrogen (2) If any of the forms of nitrogen (2) to (5) amounts to at least 1 % by weight, it must be declared		(1) Water-soluble potassium oxide (2) The indication 'low in chloride' is linked to a maximum content of 2 % Cl (3) Chloride content may be declared

B.3.2.	Type designation:	NK fertiliser containing crotonylidene diurea or isobutylidene diurea or urea formaldehyde (as appropriate).
	Data on method of production:	Product obtained chemically without addition of organic nutrients of animal or vegetable origin and containing crotonylidene diurea or isobutylidene diurea or urea formaldehyde.
	Minimum content of nutrients (percentage by weight):	<ul style="list-style-type: none"> — Total: 18 % (N + K₂O); — For each of the nutrients: <ul style="list-style-type: none"> — 5 % N At least ¼ of the declared content of total nitrogen must derive from nitrogen form (5) or (6) or (7). At least 3/5 of the declared nitrogen content (7) must be soluble in hot water, — 5 % K₂O.

▼B

Forms, solubilities and nutrient content to be declared as specified in columns 4, 5 and 6 Particle size			Data for identification of the fertilisers Other requirements		
N	P ₂ O ₅	K ₂ O	N	P ₂ O ₅	K ₂ O
1	2	3	4	5	6
(1) Total nitrogen (2) Nitric nitrogen (3) Ammoniacal nitrogen (4) Ureic nitrogen (5) Nitrogen from crotonylidene diurea (6) Nitrogen from isobutylidene diurea (7) Nitrogen from urea formaldehyde (8) Nitrogen from urea formaldehyde that is only soluble in hot water (9) Nitrogen from urea formaldehyde that is soluble in cold water		Water-soluble K ₂ O	(1) Total nitrogen (2) If any of the forms of nitrogen (2) to (4) amounts to at least 1 % by weight, it must be declared (3) One of the forms of nitrogen (5) to (7) (as appropriate). Nitrogen form (7) must be declared in the form of nitrogen (8) and (9)		(1) Water-soluble potassium oxide (2) The indication 'low in chloride' is linked to a maximum content of 2 % Cl (3) Chloride content may be declared

B.4. PK fertilisers

Type designation:	PK fertilisers.
Data on method of production:	Product obtained chemically or by blending, without addition of organic nutrients of animal or vegetable origin.
Minimum content of nutrients (percentage by weight):	— Total: 18 % (P ₂ O ₅ + K ₂ O); — For each of the nutrients: 5 % P ₂ O ₅ , 5 % K ₂ O.

▼B

Forms, solubilities and nutrient content to be declared as specified in columns 4, 5 and 6			Data for identification of the fertilisers		
Particle size			Other requirements		
N	P ₂ O ₅	K ₂ O	N	P ₂ O ₅	K ₂ O
1	2	3	4	5	6
	(1) Water-soluble P ₂ O ₅ (2) P ₂ O ₅ soluble in neutral ammonium citrate (3) P ₂ O ₅ soluble in neutral ammonium citrate and in water (4) P ₂ O ₅ soluble in mineral acids only (5) P ₂ O ₅ soluble in alkaline ammonium citrate (Petermann) (6a) P ₂ O ₅ soluble in mineral acids, of which at least 75 % of the declared P ₂ O ₅ content is soluble in 2 % citric acid (6b) P ₂ O ₅ soluble in 2 % citric acid (7) P ₂ O ₅ soluble in mineral acids of which at least 75 % of the declared P ₂ O ₅ content is soluble in alkaline ammonium citrate (Joulie) (8) P ₂ O ₅ soluble in mineral acids, of which at least 55 % of the declared P ₂ O ₅ content is soluble in 2 % formic acid	Water soluble K ₂ O		1. A PK fertiliser free from Thomas slag, calcined phosphate, aluminium-calcium phosphate, partially solubilised rock phosphate and soft ground rock phosphate must be declared in accordance with solubilities (1), (2) or (3): — when the water-soluble P ₂ O ₅ does not amount to 2 % solubility (2) only shall be declared; — when the water-soluble P ₂ O ₅ is at least 2 % solubility (3) shall be declared and the water-soluble P ₂ O ₅ content must be indicated [solubility (1)]. The P ₂ O ₅ content soluble in mineral acids only must not exceed 2 %. For this type 1, the test sample for determining solubilities (2) and (3) shall be 1 g. 2 (a) A PK fertiliser containing soft ground rock phosphate or partially solubilised rock phosphate must be free from Thomas slag, calcined phosphate and aluminium-calcium phosphate. It shall be declared in accordance with solubilities (1), (3) and (4) This type of fertiliser must contain: — at least 2 % P ₂ O ₅ soluble in mineral acids only [solubility (4)];	(1) Water-soluble potassium oxide (2) The indication 'low in chloride' is linked to a maximum content of 2 % Cl (3) Chloride content may be declared

▼B

1	2	3	4	5	6
<p>Particle size of the basic phosphatic ingredients:</p> <p>Thomas slag</p> <p>Aluminium-calcium phosphate</p> <p>Calcined phosphate</p> <p>Soft ground rock phosphate</p> <p>Partially solubilised rock phosphate</p>	<p>at least 75 % able to pass through a sieve with a mesh of 0,160 mm</p> <p>at least 90 % able to pass through a sieve with a mesh of 0,160 mm</p> <p>at least 75 % able to pass through a sieve with a mesh of 0,160 mm</p> <p>at least 90 % able to pass through a sieve with a mesh of 0,063 mm</p> <p>at least 90 % able to pass through a sieve with a mesh of 0,160 mm</p>			<p>— at least 5 % P₂O₅ soluble in water and neutral ammonium citrate [solubility (3)];</p> <p>— at least 2,5 % water-soluble P₂O₅ [solubility (1)].</p> <p>This type of fertiliser must be marketed under the designation ‘PK fertiliser containing soft ground rock phosphate’ or ‘PK fertiliser containing partially solubilised rock phosphate’.</p> <p>For this type 2(a), the test sample for determining solubility (3) shall be 3 g</p> <p>2 (b) A PK fertiliser containing aluminium-calcium phosphate must be free from Thomas slag, calcined phosphate and partially solubilised rock phosphate.</p> <p>It shall be declared in accordance with solubilities (1) and (7), the latter applying after deduction of the solubility in water.</p> <p>This type of fertiliser must contain:</p> <p>— at least 2 % water-soluble P₂O₅ [solubility (1)];</p> <p>— at least 5 % P₂O₅ according to solubility (7).</p> <p>This type of fertiliser must be marketed under the designation ‘PK fertiliser containing aluminium-calcium phosphate’.</p> <p>3. In the case of PK fertilisers containing only one of the following types of phosphatic fertiliser: Thomas slag, calcined phosphate, aluminium-calcium phosphate, soft ground rock phosphate, the type designation must be followed by an indication of the phosphate ingredient.</p>	

▼B

1	2	3	4	5	6
				<p>The declaration of the solubility of the P₂O₅ must be given in accordance with the following solubilities:</p> <ul style="list-style-type: none"> — for fertilisers based on Thomas slag: solubility (6a) (France, Italy, Spain, Portugal, Greece ► M1, Czech Republic, Estonia, Cyprus, Latvia, Lithuania, Hungary, Malta, Poland, Slovenia, Slovakia, ◀ ► M3 Bulgaria, Romania ◀), (6b) (Germany, Belgium, Denmark, Ireland, Luxembourg, Netherlands, United Kingdom and Austria) — for fertilisers based on calcined phosphate: solubility (5); — for fertilisers based on aluminium-calcium phosphate: solubility (7); — for fertilisers based on soft ground rock phosphate: solubility (8). 	

C. **Inorganic fluid fertilisers**

C.1. *Straight fluid fertilisers*

No	Type designation	Data on method of production and essential ingredients	Minimum content of nutrients (percentage by weight) Data on the expression of nutrients Other requirements	Other data or type designation	Nutrient content to be declared Forms and solubilities of the nutrients Other criteria
1	2	3	4	5	6
1	Nitrogen fertiliser solution	Product obtained chemically and by dissolution in water, in a form stable at atmospheric pressure, without addition of organic nutrients of animal or vegetable origin	15 % N Nitrogen expressed as total nitrogen or, if there is only one form, nitric nitrogen or ammoniacal nitrogen or ureic nitrogen Maximum biuret content: ureic N × 0,026		Total nitrogen and, for any form that amounts to not less than 1 %, nitric nitrogen, ammoniacal nitrogen and/or ureic nitrogen If the biuret content is less than 0,2 %, the words 'low in biuret' may be added

▼B

1	2	3	4	5	6
2	Urea Ammonium nitrate fertiliser solution	Product obtained chemically and by dissolution in water, containing ammonium nitrate and urea	26 % N Nitrogen expressed as total nitrogen, where the ureic nitrogen accounts for about half of the nitrogen present Maximum biuret content: 0,5 %		Total nitrogen Nitric nitrogen, ammoniacal nitrogen and ureic nitrogen If the biuret content is less than 0,2 %, the words 'low in biuret' may be added
3	Calcium nitrate solution	Product obtained by dissolving calcium nitrate in water	8 % N Nitrogen expressed as nitrogen in nitric form with a maximum 1 % nitrogen as ammonia Calcium expressed as water soluble CaO	The type designation may be followed, as appropriate, by one of the following indications: — for foliar application; — for making nutrient solutions; — for ferti-irrigation.	Total nitrogen Water soluble calcium oxide for the uses stipulated in column 5 Optionally: — nitrogen in nitric form; — nitrogen as ammonia.
4	Magnesium nitrate solution	Product obtained chemically and by dissolving magnesium nitrate in water	6 % N Nitrogen expressed as nitric nitrogen 9 % MgO Magnesium expressed as water-soluble magnesium oxide Minimum pH: 4		Nitric nitrogen Water-soluble magnesium oxide
5	Calcium nitrate suspension	Product obtained by suspension of calcium nitrate in water	8 % N Nitrogen expressed as total nitrogen or nitric and ammoniacal nitrogen maximum content of ammoniacal nitrogen: 1,0 % 14 % CaO Calcium expressed as water soluble CaO	The type designation may be followed by one of the following indications: — for foliar application; — for making nutrient solutions and suspensions; — for fertigation.	Total nitrogen Nitric nitrogen Water soluble calcium oxide for the uses stipulated in column 5

▼B

1	2	3	4	5	6
6	Nitrogen fertiliser solution with urea formaldehyde	Product obtained chemically or by dissolution in water of urea formaldehyde and a nitrogenous fertiliser from list A-1 in this regulation, excluding products 3(a), 3(b), and 5	18 % N expressed as total nitrogen At least one third of the declared total nitrogen content must derive from urea formaldehyde Maximum biuret content: (ureic N + urea formaldehyde N) × 0,026		Total nitrogen For each form amounting to at least 1 %: — Nitric nitrogen; — Ammoniacal nitrogen; — Ureic nitrogen. Nitrogen from urea formaldehyde
7	Nitrogen fertiliser suspension with urea formaldehyde	Product obtained chemically or by suspension in water of urea formaldehyde and a nitrogenous fertiliser from list A-1 in this regulation, excluding products 3(a), 3(b), and 5	18 % N expressed as total nitrogen At least one third of the declared total nitrogen content must derive from urea formaldehyde of which at least three fifths has to be soluble in hot water Maximum biuret content: (ureic N + urea formaldehyde N) × 0,026		Total nitrogen For each form amounting to at least 1 % — Nitric nitrogen; — Ammoniacal nitrogen; — Ureic nitrogen. Nitrogen from urea formaldehyde Nitrogen from urea formaldehyde that is soluble in cold water Nitrogen from urea formaldehyde that is only soluble in hot water

C.2. Compound fluid fertilisers

C.2.1.	Type designation:	NPK-fertiliser solution.
	Data on method of production:	Product obtained chemically and by dissolution in water, in a form stable at atmospheric pressure, without addition of organic nutrients of animal or vegetable origin.
	Minimum content of nutrients (percentage by weight) and other requirements:	<ul style="list-style-type: none"> — Total: 15 %, (N + P₂O₅ + K₂O); — For each of the nutrients: 2 % N, 3 % P₂O₅, 3 % K₂O; — Maximum biuret content: ureic N × 0,026.

▼B

Forms, solubilities and nutrient content to be declared as specified in columns 4, 5 and 6 Particle size			Data for identification of the fertilisers Other requirements		
N	P ₂ O ₅	K ₂ O	N	P ₂ O ₅	K ₂ O
1	2	3	4	5	6
(1) Total nitrogen (2) Nitric nitrogen (3) Ammoniacal nitrogen (4) Ureic nitrogen	Water-soluble P ₂ O ₅	Water-soluble K ₂ O	(1) Total nitrogen (2) If any of the forms of nitrogen (2) to (4) amounts to not less than 1 % by weight, it must be declared (3) If the biuret content is less than 0,2 %, the words 'low in biuret' may be added	Water-soluble P ₂ O ₅	(1) Water-soluble potassium oxide (2) The words 'low in chloride' may be used only where the Cl content does not exceed 2 % (3) The chloride content may be declared

C.2.2.	Type designation:	NPK-fertiliser suspension.
	Data on method of production:	Product in liquid form, in which the nutrients are derived from substances both in suspension in the water and in solution without addition of organic nutrients of animal or vegetable origin.
	Minimum content of nutrients (percentage by weight) and other requirements:	<ul style="list-style-type: none"> — Total: 20 %, (N + P₂O₅ + K₂O); — For each of the nutrients: 3 % N, 4 % P₂O₅, 4 % K₂O; — Maximum biuret content: ureic N × 0,026.

▼B

Forms, solubilities and nutrient content to be declared as specified in columns 4, 5 and 6 Particle size			Data for identification of the fertilisers Other requirements		
N	P ₂ O ₅	K ₂ O	N	P ₂ O ₅	K ₂ O
1	2	3	4	5	6
(1) Total nitrogen (2) Nitric nitrogen (3) Ammoniacal nitrogen (4) Ureic nitrogen	(1) Water-soluble P ₂ O ₅ (2) P ₂ O ₅ soluble in neutral ammonium citrate (3) P ₂ O ₅ soluble in neutral ammonium citrate and water	Water-soluble K ₂ O	(1) Total nitrogen (2) If any of the forms of nitrogen 2 to 4 amounts to not less than 1 % by weight, it must be declared (3) If the biuret content is less than 0,2 %, the words 'low in biuret' may be added	The fertilisers must not contain Thomas slag, aluminium calcium phosphate, calcined phosphates, partially solubilised phosphates or rock phosphates (1) If the water-soluble P ₂ O ₅ is less than 2 %, only solubility 2 shall be declared (2) If the water-soluble P ₂ O ₅ is at least 2 %, solubility 3 and the water-soluble P ₂ O ₅ content shall be declared	(1) Water-soluble potassium oxide (2) The words 'low in chloride' may be used only where the Cl content does not exceed 2 % (3) The chloride content may be declared

C.2.3.	Type designation:	NP-fertiliser solution.
	Data on method of production:	Product obtained chemically and by dissolution in water, in a form stable at atmospheric pressure, without addition of organic nutrients of animal or vegetable origin.
	Minimum content of nutrients (percentage by weight):	<ul style="list-style-type: none"> — Total: 18 %, (N + P₂O₅); — For each of the nutrients: 3 % N, 5 % P₂O₅; — Maximum biuret content: ureic N × 0,026.

▼B

Forms, solubilities and nutrient content to be declared as specified in columns 4, 5 and 6			Data for identification of the fertilisers		
Particle size			Other requirements		
N	P ₂ O ₅	K ₂ O	N	P ₂ O ₅	K ₂ O
1	2	3	4	5	6
(1) Total nitrogen (2) Nitric nitrogen (3) Ammoniacal nitrogen (4) Ureic nitrogen	P ₂ O ₅ Water-soluble		(1) Total nitrogen (2) If any of the forms of nitrogen (2) to (4) amounts to not less than 1 % by weight, it must be declared. (3) If the biuret content is less than 0,2 %, the words 'low in biuret' may be added	Water-soluble P ₂ O ₅	

C.2.4.	Type designation:	NP-fertiliser suspension.
	Data on method of production:	Product in liquid form, in which the nutrients are derived from substances both in solution and in suspension in the water, without addition of organic nutrients of animal or vegetable origin.
	Minimum content of nutrients (percentage by weight):	<ul style="list-style-type: none"> — Total: 18 %, (N + P₂O₅); — For each of the nutrients: 3 % N, 5 % P₂O₅; — Maximum biuret content: ureic N × 0,026.

▼B

Forms, solubilities and nutrient content to be declared as specified in columns 4, 5 and 6			Data for identification of the fertilisers		
Particle size			Other requirements		
N	P ₂ O ₅	K ₂ O	N	P ₂ O ₅	K ₂ O
1	2	3	4	5	6
(1) Total nitrogen (2) Nitric nitrogen (3) Ammoniacal nitrogen (4) Ureic nitrogen	(1) Water-soluble P ₂ O ₅ (2) P ₂ O ₅ soluble in neutral ammonium citrate (3) P ₂ O ₅ soluble in neutral ammonium citrate and water		(1) Total nitrogen (2) If any of the forms of nitrogen (2) to (4) amounts to not less than 1 % by weight, it must be declared. (3) If the biuret content is less than 0,2 %, the words 'low in biuret' may be added	(1) If the water-soluble P ₂ O ₅ is less than 2 % only solubility 2 shall be declared (2) If the water-soluble P ₂ O ₅ is at least 2 %, solubility 3 will be declared and the water-soluble P ₂ O ₅ content must be stated. The fertilisers may not contain Thomas slag, aluminium calcium phosphate, calcined phosphates, partially solubilised phosphate or rock phosphates	

C.2.5.	Type designation:	NK-fertiliser solution.
	Data on method of production:	Product obtained chemically and by dissolution in water, in a form stable at atmospheric pressure, without addition of organic nutrients of animal or vegetable origin.
	Minimum content of nutrients (percentage by weight):	— Total: 15 % (N + K ₂ O); — For each of the nutrients: 3 % N, 5 % K ₂ O; — Maximum biuret content: ureic N × 0,026.

▼B

Forms, solubilities and nutrient content to be declared as specified in columns 4, 5 and 6 Particle size			Data for identification of the fertilisers Other requirements		
N	P ₂ O ₅	K ₂ O	N	P ₂ O ₅	K ₂ O
1	2	3	4	5	6
(1) Total nitrogen (2) Nitric nitrogen (3) Ammoniacal nitrogen (4) Ureic nitrogen		Water-soluble K ₂ O	(1) Total nitrogen (2) If any of the forms of nitrogen (2) to (4) amounts to not less than 1 % by weight, it must be declared (3) If the biuret content is less than 0,2 %, the words 'low in biuret' may be added		(1) Water-soluble potassium oxide (2) The words 'low in chloride' may be used only where the Cl content does not exceed 2 % (3) The chloride content may be declared

C.2.6.	Type designation:	NK-fertiliser suspension.
	Data on method of production:	Product in liquid form, in which the nutrients are derived from substances both in solution and in suspension in the water, without addition of organic nutrients of animal or vegetable origin.
	Minimum content of nutrients (percentage by weight):	<ul style="list-style-type: none"> — Total: 18 % (N + K₂O); — For each of the nutrients: 3 % N, 5 % K₂O; — Maximum biuret content: ureic N × 0,026.

Forms, solubilities and nutrient content to be declared as specified in columns 4, 5 and 6 Particle size			Data for identification of the fertilisers Other requirements		
N	P ₂ O ₅	K ₂ O	N	P ₂ O ₅	K ₂ O
1	2	3	4	5	6
(1) Total nitrogen (2) Nitric nitrogen (3) Ammoniacal nitrogen (4) Ureic nitrogen		Water-soluble K ₂ O	(1) Total nitrogen (2) If any of the forms of nitrogen (2) to (4) amounts to not less than 1 % by weight, it must be declared (3) If the biuret content is less than 0,2 %, the words 'low in biuret' may be added		(1) Water-soluble potassium oxide (2) The words 'low in chloride' may be used only where the Cl content does not exceed 2 % (3) The chloride content may be declared

▼B

C.2.7.	Type designation:	PK-fertiliser solution.
	Data on method of production:	Product obtained chemically and by dissolution in water, without addition of organic nutrients of animal or vegetable origin.
	Minimum content of nutrients (percentage by weight):	— Total: 18 % (P ₂ O ₅ + K ₂ O); — For each of the nutrients: 5 % P ₂ O ₅ , 5 % K ₂ O.

Forms, solubilities and nutrient content to be declared as specified in columns 4, 5 and 6 Particle size			Data for identification of the fertilisers Other requirements		
N	P ₂ O ₅	K ₂ O	N	P ₂ O ₅	K ₂ O
1	2	3	4	5	6
	Water-soluble P ₂ O ₅	Water-soluble K ₂ O		Water-soluble P ₂ O ₅	(1) Water-soluble potassium oxide (2) The words 'low in chloride' may be used only where the Cl content does not exceed 2 % (3) The chloride content may be declared

C.2.8.	Type designation:	PK-fertiliser suspension.
	Data on method of production:	Product in liquid form, in which the nutrients are derived from substances both in solution and in suspension in water, without addition of organic nutrients of animal or vegetable origin.
	Minimum content of nutrients (percentage by weight):	— Total: 18 % (P ₂ O ₅ + K ₂ O); — For each of the nutrients: 5 % P ₂ O ₅ , 5 % K ₂ O.

▼B

Forms, solubilities and nutrient content to be declared as specified in columns 4, 5 and 6 Particle size			Data for identification of the fertilisers Other requirements		
N	P ₂ O ₅	K ₂ O	N	P ₂ O ₅	K ₂ O
1	2	3	4	5	6
	(1) Water-soluble P ₂ O ₅ (2) P ₂ O ₅ soluble in neutral ammonium citrate (3) P ₂ O ₅ soluble in neutral ammonium citrate and water	Water-soluble K ₂ O		(1) If the water-soluble P ₂ O ₅ is less than 2 % only solubility 2 will be declared (2) If the water-soluble P ₂ O ₅ is at least 2 % solubility 3 and the water-soluble P ₂ O ₅ content shall be declared The fertilisers must not contain Thomas slag, aluminium calcium phosphate, calcined phosphates, partially solubilised phosphates or rock phosphates	(1) Water-soluble potassium oxide (2) The words 'low in chloride' may be used only where the Cl content does not exceed 2 % (3) The chloride content may be declared

▼B

D. Inorganic secondary nutrient fertilisers

No	Type designation	Data on method of production and essential ingredients	Minimum content of nutrients (percentage by weight) Data on the expression of nutrients Other requirements	Other data or type designation	Nutrient content to be declared Forms and solubilities of the nutrients Other criteria
1	2	3	4	5	6
1	Calcium sulphate	Product of natural or industrial origin containing calcium sulphate at various degrees of hydration	25 % CaO 35 % SO ₃ Calcium and sulphur expressed as total CaO + SO ₃ Fineness of grind: — at least 80 % to pass through a sieve with a 2 mm mesh width, — at least 99 % to pass through a sieve with a 10 mm mesh width	Usual trade names may be added	Total sulphur trioxide Optional: total CaO
2	Calcium chloride solution	Calcium chloride solution of industrial origin	12 % CaO Calcium expressed as water-soluble CaO		Calcium oxide Optional: for plant spraying
▼ <u>M8</u> 2.1	Calcium formate	Chemically obtained product containing calcium formate as essential ingredient	33,6 % CaO Calcium expressed as water-soluble CaO 56 % formate		Calcium oxide Formate
2.2	Calcium formate fluid	Product obtained by dissolution in water of calcium formate	21 % CaO Calcium expressed as water-soluble CaO 35 % formate		Calcium oxide Formate
▼ <u>B</u> 3	Elemental sulphur	Comparatively refined natural or industrial product	98 % S (245 %: SO ₃) Sulphur expressed as total SO ₃		Total sulphur trioxide
4	Kieserite	Product of mineral origin containing monohydrated magnesium sulphate as main component	24 % MgO 45 % SO ₃ Magnesium and sulphur expressed as water-soluble magnesium oxide and sulphur trioxide	Usual trade names may be added	Water-soluble magnesium oxide Optional: water-soluble sulphur trioxide

▼M7

1	2	3	4	5	6
5	Magnesium sulphate	Product containing heptahydrated magnesium sulphate as main ingredient	15 % MgO 28 % SO ₃ Where micro-nutrients are added, and declared in accordance with Article 6(4) and 6(6): 10 % MgO 17 % SO ₃ Magnesium and sulphur expressed as water-soluble magnesium oxide and sulphur trioxide	The usual trade names may be added	Water-soluble magnesium oxide Water-soluble sulphur trioxide
5.1	Magnesium sulphate solution	Product obtained by dissolution in water of magnesium sulphate of industrial origin	5 % MgO 10 % SO ₃ Magnesium and sulphur expressed as water-soluble magnesium oxide and water-soluble sulphuric anhydride	Usual trade names may be added	Water-soluble magnesium oxide Optional: water-soluble sulphuric anhydride
5.2	Magnesium hydroxide	Product obtained chemically and having as its essential ingredient magnesium hydroxide	60 % MgO Particle size: at least 99 % able to pass through a sieve with a mesh of 0,063 mm		Total magnesium oxide
5.3	Suspension of magnesium hydroxide	Product obtained by suspension of type 5.2	24 % MgO		Total magnesium oxide
6	Magnesium chloride solution	Product obtained by dissolving magnesium chloride of industrial origin	13 % MgO Magnesium expressed as magnesium oxide Maximum calcium content: 3 % CaO		Magnesium oxide

▼B

▼**B**

E. **Inorganic micro-nutrient fertilisers**

Explanatory note: The following notes are applicable to the whole of Part E.

Note 1: A chelating agent may be designated by means of its initials as set out in E.3.

Note 2: If the product leaves no solid residue after being dissolved in water it may be described as 'for dissolution'.

Note 3: Where a micro-nutrient is present in a chelated form, the pH range guaranteeing acceptable stability of the chelated fraction shall be stated.

E.1. *Fertilisers containing only one micro-nutrient*

E.1.1. *Boron*

No	Type designation	Data on method of production and essential ingredients	Minimum content of nutrients (percentage by weight) Data on the expression of nutrients Other requirements	Other data on the type of designation	Nutrient content to be declared Forms and solubilities of the nutrients Other criteria
1	2	3	4	5	6
1a	Boric acid	Product obtained by the action of an acid on a borate	14 % water-soluble B	The usual trade names may be added	Water-soluble boron (B)
1b	Sodium borate	Chemically obtained product containing as its essential component a sodium borate	10 % water-soluble B	The usual trade names may be added	Water-soluble boron (B)
1c	Calcium borate	Product obtained from colemanite or pandermite containing as its essential ingredient calcium borates	7 % total B Particle size: at least 98 % passing through a 0,063 mm sieve	The usual trade names may be added	Total boron (B)
1d	Boron ethanol amine	Product obtained by reacting a boric acid with an ethanol amine	8 % water-soluble B		Water-soluble boron (B)
1e	Borated fertiliser in solution	Product obtained by dissolving types 1a and/or 1b and/or 1d	2 % water-soluble B	The designation must include the names of the constituents present	Water-soluble boron (B)
1f	Borated fertiliser in suspension	Product obtained by suspending types 1a and/or 1b and/or 1d in water	2 % water-soluble B	The designation must include the names of the constituents present	Water-soluble boron (B)

▼**B**

E.1.2. *Cobalt*

No	Type designation	Data on method of production and essential ingredients	Minimum content of nutrients (percentage by weight) Data on the expression of nutrients Other requirements	Other data on the type of designation	Nutrient content to be declared Forms and solubilities of the nutrients Other criteria
1	2	3	4	5	6
2a	Cobalt salt	Chemically obtained product containing a mineral salt of cobalt as its essential ingredient	19 % water-soluble Co	The designation must include the name of the mineral anion	Water-soluble cobalt (Co)
2b	Cobalt chelate	Water-soluble product containing cobalt chemically combined with authorised chelating agent(s)	5 % of water-soluble cobalt and at least 80 % of the water-soluble cobalt is chelated by authorised chelating agent(s)	Name of each authorised chelating agent that chelates at least 1 % water-soluble cobalt and that can be identified and quantified by a European standard	Water-soluble cobalt (Co) Optional: Total cobalt (Co) chelated by authorised chelating agents Cobalt (Co) chelated by each authorised chelating agent that chelates at least 1 % water-soluble cobalt and that can be identified and quantified by a European standard
2c	Cobalt fertiliser solution	Aqueous solution of types 2a and/or types 2b	2 % water-soluble cobalt	The designation must include: (1) the name(s) of the mineral anion(s) (2) the name of any authorised chelating agent that chelates at least 1 % water-soluble cobalt if present and that can be identified and quantified by a European standard	Water-soluble cobalt (Co) Optional: Total cobalt (Co) chelated by authorised chelating agents Cobalt (Co) chelated by each authorised chelating agent that chelates at least 1 % water-soluble cobalt and that can be identified and quantified by a European standard

▼**M8**

▼ **M9**

1	2	3	4	5	6
2d	Cobalt complex	Water-soluble product containing cobalt chemically combined with one authorised complexing agent	5 % of water-soluble Co and the complexed fraction must be at least 80 % of the water-soluble cobalt	The designation must include the name of the authorised complexing agent that can be identified by a European Standard	Water-soluble cobalt (Co) Total cobalt (Co) complexed

▼ **B**

E.1.3. *Copper*

No	Type designation	Data on method of production and essential ingredients	Minimum content of nutrients (percentage by weight) Data on the expression of nutrients Other requirements	Other data on the type of designation	Nutrient content to be declared Forms and solubilities of the nutrients Other criteria
1	2	3	4	5	6
3a	Copper salt	Chemically obtained product containing a mineral salt of copper as its essential ingredient	20 % water-soluble Cu	The designation must include the name of the mineral anion	Water-soluble copper (Cu)
3b	Copper oxide	Chemically obtained product containing copper oxide as its essential ingredient	70 % total Cu Particle size: at least 98 % passing through a 0,063 mm sieve		Total copper (Cu)
3c	Copper hydroxide	Chemically obtained product containing copper hydroxide as its essential ingredient	45 % total Cu Particle size: at least 98 % passing through a 0,063 mm sieve		Total copper (Cu)
3d	Copper chelate	Water-soluble product containing copper chemically combined with authorised chelating agent(s)	5 % of water-soluble copper and at least 80 % of the water-soluble copper is chelated by authorised chelating agent(s)	Name of each authorised chelating agent that chelates at least 1 % water-soluble copper and that can be identified and quantified by a European standard	Water-soluble copper (Cu) Optional: Total copper (Cu) chelated by authorised chelating agents Copper (Cu) chelated by each authorised chelating agent that chelates at least 1 % water-soluble copper and that can be identified and quantified by a European standard

▼ **M8**

▼ **B**

1	2	3	4	5	6
3e	Copper-based fertiliser	Product obtained by mixing types 3a and/or 3b and/or 3c and/or a single one of type 3d and, if required, filler that is neither nutrient nor toxic	5 % total Cu	The designation must include: (1) the name(s) of the copper components; (2) the name of any chelating agent if present	Total copper (Cu) Water-soluble copper (Cu) if this accounts for at least 1/4 of the total copper Chelated copper (Cu) if present
▼ M8					
3f	Copper fertiliser solution	Aqueous solution of types 3a and/or types 3d	2 % water-soluble copper	The designation must include: (1) the name(s) of the mineral anion(s) (2) the name of any authorised chelating agent that chelates at least 1 % water-soluble copper if present and that can be identified and quantified by a European standard	Water-soluble copper (Cu) Optional: Total copper (Cu) chelated by authorised chelating agents Copper (Cu) chelated by each authorised chelating agent that chelates at least 1 % water-soluble copper and that can be identified and quantified by a European standard
▼ B					
3g	Copper oxychloride	Chemically obtained product containing copper oxychloride $[\text{Cu}_2\text{Cl}(\text{OH})_3]$ as an essential ingredient	50 % total Cu Particle size: at least 98 % passing through a 0,063 mm sieve		Total copper (Cu)
3h	Copper oxychloride suspension	Product obtained by suspension of type 3 g	17 % total Cu		Total copper (Cu)
▼ M9					
3i	Copper complex	Water-soluble product containing copper chemically combined with one authorised complexing agent	5 % of water-soluble Cu and the complexed fraction must be at least 80 % of the water-soluble copper	The designation must include the name of the authorised complexing agent that can be identified by a European Standard	Water-soluble copper (Cu) Total copper (Cu) complexed

▼ **M4**

E.1.1.4. *Iron*

No	Type designation	Data on method of production and essential ingredients	Minimum content of nutrients (percentage by weight) Data on the expression of nutrients Other requirements	Other data on the type of designation	Nutrient content to be declared Forms and solubilities of the nutrients Other criteria
1	2	3	4	5	6
4a	Iron salt	Chemically obtained product containing a mineral iron salt as its essential ingredient	12 % water-soluble Fe	The designation must include the name of the mineral anion	Water-soluble iron (Fe)
4b	Iron chelate	Water-soluble product containing iron chemically combined with authorised chelating agent(s)	5 % of water-soluble iron, of which the chelated fraction is at least 80 % and at least 50 % of the water-soluble iron is chelated by authorised chelating agent(s)	Name of each authorised chelating agent that chelates at least 1 % water-soluble iron and that can be identified and quantified by a European standard	Water-soluble iron (Fe) Optional: Total iron (Fe) chelated by authorised chelating agents Iron (Fe) chelated by each authorised chelating agent that chelates at least 1 % water-soluble iron and that can be identified and quantified by a European standard
4c	Iron fertiliser solution	Aqueous solution of types 4a and/or types 4b	2 % of water soluble iron	The designation must include: (1) the name(s) of the mineral anion(s) (2) the name of any authorised chelating agent that chelates at least 1 % water-soluble iron if present and that can be identified and quantified by a European standard	Water-soluble iron (Fe) Optional: Total iron (Fe) chelated by authorised chelating agents Iron (Fe) chelated by each authorised chelating agent that chelates at least 1 % water-soluble iron and that can be identified and quantified by a European standard

▼ **M8**

▼ **M9**

1	2	3	4	5	6
4d	Iron complex	Water-soluble product containing iron chemically combined with one authorised complexing agent	5 % of water-soluble Fe and the complexed fraction must be at least 80 % of the water-soluble iron	The designation must include the name of the authorised complexing agent that can be identified by a European Standard	Water-soluble iron (Fe) Total iron (Fe) complexed

▼ **B**

E.1.5. *Manganese*

No	Type designation	Data on method of production and essential ingredients	Minimum content of nutrients (percentage by weight) Data on the expression of nutrients Other requirements	Other data on the type of designation	Nutrient content to be declared Forms and solubilities of the nutrients Other criteria
1	2	3	4	5	6
5a	Manganese salt	Chemically obtained product containing a mineral manganese salt (Mn II) as its essential ingredient	17 % water-soluble Mn	The designation must include the name of the combined anion	Water-soluble manganese (Mn)
5b	Manganese chelate	Water-soluble product containing manganese chemically combined with authorised chelating agent(s)	5 % of water-soluble manganese and at least 80 % of the water-soluble manganese is chelated by authorised chelating agent(s)	Name of each authorised chelating agent that chelates at least 1 % water-soluble manganese and that can be identified and quantified by a European standard	Water-soluble manganese (Mn) Optional: Total manganese (Mn) chelated by authorised chelating agents Manganese (Mn) chelated by each authorised chelating agent that chelates at least 1 % water-soluble manganese and that can be identified and quantified by a European standard
5c	Manganese oxide	Chemically obtained product containing manganese oxides as essential ingredients	40 % total Mn Particle size: at least 80 % passing through a 0,063 mm sieve		Total manganese (Mn)

▼ **M8**

▼ **B**

▼ **B**

1	2	3	4	5	6
5d	Manganese-based fertiliser	Product obtained by mixing types 5a and 5c	17 % total Mn	The designation must include the name of the manganese components	Total manganese (Mn) Water-soluble manganese (Mn) if this accounts for at least 1/4 of the total manganese

▼ **M8**

5e	Manganese solution fertiliser	Aqueous solution of types 5a and/or types 5b	2 % water-soluble manganese	The designation must include: (1) the name(s) of the mineral anion(s) (2) the name of any authorised chelating agent that chelates at least 1 % water-soluble manganese if present and that can be identified and quantified by a European standard	Water-soluble manganese (Mn) Optional: Total manganese (Mn) chelated by authorised chelating agents Manganese (Mn) chelated by each authorised chelating agent that chelates at least 1 % water-soluble manganese and that can be identified and quantified by a European standard
----	-------------------------------	--	-----------------------------	---	--

▼ **M9**

5f	Manganese fertiliser in suspension	Product obtained by suspending types 5a and/or 5b and/or 5c in water	17 % total Mn	The designation must include: (1) the name(s) of the anions, if present (2) the name of any authorised chelating agent that chelates at least 1 % water-soluble manganese if present and that can be identified and quantified by a European standard	Total manganese (Mn) Water-soluble manganese (Mn) if present Manganese (Mn) chelated by each authorised chelating agent that chelates at least 1 % water-soluble manganese and that can be identified and quantified by a European standard
5g	Manganese complex	Water-soluble product containing manganese chemically combined with one authorised complexing agent	5 % of water-soluble Mn and the complexed fraction must be at least at least 80 % of the water-soluble manganese	The designation must include the name of the authorised complexing agent that can be identified by a European Standard	Water-soluble manganese (Mn) Total manganese (Mn) complexed

▼B

E.1.6. *Molybdenum*

No	Type designation	Data on method of production and essential ingredients	Minimum content of nutrients (percentage by weight) Data on the expression of nutrients Other requirements	Other data on the type of designation	Nutrient content to be declared Forms and solubilities of the nutrients Other criteria
1	2	3	4	5	6
6a	Sodium molybdate	Chemically obtained product containing sodium molybdate as its essential ingredient	35 % water-soluble Mo		Water-soluble molybdenum (Mo)
6b	Ammonium molybdate	Chemically obtained product containing ammonium molybdate as its essential ingredient	50 % water-soluble Mo		Water-soluble molybdenum (Mo)
6c	Molybdenum-based fertiliser	Product obtained by mixing types 6a and 6b	35 % water-soluble Mo	The designation must include the names of the molybdenum components	Water-soluble molybdenum (Mo)
6d	Molybdenum-based fertiliser solution	Product obtained by dissolving types 6a and/or one of the type 6b in water	3 % water-soluble Mo	The designation must include the name(s) of the molybdenum component(s)	Water-soluble molybdenum (Mo)

E.1.7. *Zinc*

No	Type designation	Data on method of production and essential ingredients	Minimum content of nutrients (percentage by weight) Data on the expression of nutrients Other requirements	Other data on the type of designation	Nutrient content to be declared Forms and solubilities of the nutrients Other criteria
1	2	3	4	5	6
7a	Zinc salt	Chemically obtained product and having as its essential ingredient a mineral salt of zinc	15 % water-soluble Zn	The designation must include the name of the mineral anion	Water-soluble zinc (Zn)

▼ **M8**

1	2	3	4	5	6
7b	Zinc chelate	Water-soluble product containing zinc chemically combined with authorised chelating agent(s)	5 % of water-soluble zinc and at least 80 % of the water-soluble zinc is chelated by authorised chelating agent(s)	Name of each authorised chelating agent that chelates at least 1 % water-soluble zinc and that can be identified and quantified by a European standard	Water-soluble zinc (Zn) Optional: Total zinc (Zn) chelated by authorised chelating agents Zinc (Zn) chelated by each authorised chelating agent that chelates at least 1 % water-soluble zinc and that can be identified and quantified by a European standard

▼ **B**

7c	Zinc oxide	Chemically obtained product and having as its essential ingredient zinc oxide	70 % total Zn Particle size: at least 80 % passing through a 0,063 mm sieve		Total zinc (Zn)
----	------------	---	--	--	-----------------

7d	Zinc-based fertiliser	Product obtained by mixing types 7a and 7c	30 % total Zn	The designation must include the name of the zinc components present	Total zinc (Zn) Water-soluble zinc (Zn) if this accounts for at least 1/4 of the total zinc (Zn)
----	-----------------------	--	---------------	--	---

▼ **M8**

7e	Zinc fertiliser solution	Aqueous solution of types 7a and/or types 7b	2 % water-soluble zinc	The designation must include: (1) the name(s) of the mineral anion(s) (2) the name of any authorised chelating agent that chelates at least 1 % water-soluble zinc if present and that can be identified and quantified by a European standard	Water-soluble zinc (Zn) Optional: Total zinc (Zn) chelated by authorised chelating agents Zinc (Zn) chelated by each authorised chelating agent that chelates at least 1 % water-soluble zinc and that can be identified and quantified by a European standard
----	--------------------------	--	------------------------	--	--

▼ **M8**

1	2	3	4	5	6
7f	Zinc fertiliser suspension	Product obtained by suspending type 7(a) and/or 7(c) and/or types 7(b) in water	20 % total zinc	The designation must include: (1) the name(s) of the anions (2) the name of any authorised chelating agent that chelates at least 1 % water-soluble zinc if present and that can be identified and quantified by a European standard	Total zinc (Zn) Water-soluble zinc (Zn) if present Zinc (Zn) chelated by each authorised chelating agent that chelates at least 1 % water-soluble zinc and that can be identified and quantified by a European standard
7g	Zinc complex	Water-soluble product containing zinc chemically combined with one authorised complexing agent	5 % of water-soluble zinc and the complexed fraction must be at least 80 % of the water-soluble zinc	The designation must include the name of the authorised complexing agent that can be identified by a European Standard	Water-soluble zinc (Zn) Total zinc (Zn) complexed

▼ **M9**

▼ M8

E.2. *Minimum micro-nutrient content, percentage weight of fertiliser; mixed micro-nutrient fertiliser types*

E.2.1. *Minimum micro-nutrient content in solid or fluid mixtures of micro-nutrient fertilisers, percentage weight of fertiliser*

▼ B

	Where the micro-nutrient is present in a form that is	
	exclusively mineral	chelated or complexed
For a micro-nutrient:		
Boron (B)	0,2	0,2
Cobalt (Co)	0,02	0,02
Copper (Cu)	0,5	0,1
Iron (Fe)	2,0	0,3
Manganese (Mn)	0,5	0,1
Molybdenum (Mo)	0,02	—
Zinc (Zn)	0,5	0,1

▼ M8

E.2.2. *Minimum micro-nutrient content in EC fertilisers containing primary and/or secondary nutrient(s) with micro-nutrient(s) applied to the soil, percentage weight of fertiliser*

▼ B

	For crops or grassland	For horticultural use
Boron (B)	0,01	0,01
Cobalt (Co)	0,002	—
Copper (Cu)	0,01	0,002
Iron (Fe)	0,5	0,02
Manganese (Mn)	0,1	0,01
Molybdenum (Mo)	0,001	0,001
Zinc (Zn)	0,01	0,002

▼ M8

E.2.3. *Minimum micro-nutrient content in EC fertilisers containing primary and/or secondary nutrient(s) with micro-nutrient(s) for leaf sprays, percentage weight of fertiliser*

▼ B

Boron (B)	0,010
Cobalt (Co)	0,002
Copper (Cu)	0,002
Iron (Fe)	0,020
Manganese (Mn)	0,010
Molybdenum (Mo)	0,001
Zinc (Zn)	0,002

▼ **M8**E.2.4. *Solid or fluid mixtures of micro-nutrient fertilisers*

No	Type designation	Data on method of production and essential ingredients	Minimum total content of micro-nutrients (percentage by weight) Data on expression of nutrients Other requirements	Other data on the type designation	Nutrient content to be declared Forms and solubilities of the nutrients Other criteria
1	2	3	4	5	6
1	Mixture of micro-nutrients	Product obtained by mixing two or more E.1 type fertilisers	Total of micro-nutrients: 5 % by mass of the fertiliser Individual micro-nutrient according to Section E.2.1	The designation must include: (1) the names of any mineral anions if present (2) the name(s) of any authorised chelating agents if present	Total content of each nutrient Water soluble content of each nutrient if present Micro-nutrient chelated by each authorised chelating agent(s) if present
2	Fluid mixture of micro-nutrients	Product obtained by dissolving and/or suspending two or more E.1 type fertilisers in water	Total of micro-nutrients: 2 % by mass of the fertiliser Individual micro-nutrient according to Section E.2.1	The designation must include: (1) the names of any mineral anions if present (2) the name(s) of any authorised chelating agents if present	Total content of each nutrient Water soluble content of each nutrient if present Micro-nutrient chelated by each authorised chelating agent(s), if present

▼ **M4**E.3. *List of authorised organic chelating and complexing agents for micro-nutrients*

The following substances are authorised provided that their corresponding nutrient chelate has complied with the requirements of Council Directive 67/548/EEC ⁽¹⁾.

▼ **M9**E.3.1. *Chelating agents* ⁽²⁾

Acids, or sodium, potassium or ammonium salts of:

No	Designation	Alternative designation	Chemical formula	CAS number of the acid ⁽¹⁾
1	Ethylenediaminetetraacetic acid	EDTA	C ₁₀ H ₁₆ O ₈ N ₂	60-00-4
2	2-hydroxyethylethylenediaminetriacetic acid	HEEDTA	C ₁₀ H ₁₈ O ₇ N ₂	150-39-0
3	diethylenetriaminepentaacetic acid	DTPA	C ₁₄ H ₂₃ O ₁₀ N ₃	67-43-6
4	ethylenediamine- N,N'-di[(ortho-hydroxyphenyl)acetic acid]	[o,o] EDDHA	C ₁₈ H ₂₀ O ₆ N ₂	1170-02-1
5	ethylenediamine- N-[(ortho-hydroxyphenyl)acetic acid]- N'-[(para-hydroxyphenyl)acetic acid]	[o,p] EDDHA	C ₁₈ H ₂₀ O ₆ N ₂	475475-49-1
6	ethylenediamine- N,N'-di[(ortho-hydroxy-methylphenyl)acetic acid]	[o,o] EDDHMA	C ₂₀ H ₂₄ O ₆ N ₂	641632-90-8

⁽¹⁾ OJ 196, 16.8.1967, p. 1.

⁽²⁾ The chelating agents are to be identified and quantified by the European Standards that cover the mentioned chelating agents.

▼ **M9**

No	Designation	Alternative designation	Chemical formula	CAS number of the acid ⁽¹⁾
7	ethylenediamine- N-[(ortho-hydroxy-methyl-phenyl)acetic acid]- N'-[(para-hydroxy-methyl-phenyl)acetic acid]	[o,p] EDDHMA	C ₂₀ H ₂₄ O ₆ N ₂	641633-41-2
8	ethylenediamine- N,N'-di[(5-carboxy-2-hydroxy-xyphenyl)acetic acid]	EDDCHA	C ₂₀ H ₂₀ O ₁₀ N ₂	85120-53-2
9	ethylenediamine- N,N'-di[(2-hydroxy-5-sulfophenyl)acetic acid] and its condensation products	EDDHSA	C ₁₈ H ₂₀ O ₁₂ N ₂ S ₂ + n*(C ₁₂ H ₁₄ O ₈ N ₂ S)	57368-07-7 and 642045-40-7
10	Iminodisuccinic acid	IDHA	C ₈ H ₁₁ O ₈ N	131669-35-7
11	N,N'-di(2-hydroxybenzyl)ethylenediamine-N,N'-diacetic acid	HBED	C ₂₀ H ₂₄ N ₂ O ₆	35998-29-9

⁽¹⁾ For information only.

E.3.2. *Complexing agents* ⁽¹⁾

The following complexing agents are only permitted in products for fertigation and/or foliar application, except for Zn lignosulfonate, Fe lignosulfonate, Cu lignosulfonate and Mn lignosulfonate that can be applied directly to the soil.

Acids, or sodium, potassium or ammonium salts of:

No	Designation	Alternative designation	Chemical formula	CAS number of the acid ⁽¹⁾
1	Lignosulfonic acid	LS	No chemical formula available	8062-15-5

⁽²⁸⁾ For information only.

▼ **M5**F. **Nitrification and urease inhibitors**

The urease and nitrification inhibitors listed in the Tables F.1. and F.2. below may be added to the nitrogenous fertilisers types listed in Sections A.1., B.1., B.2., B.3., C.1. and C.2. of Annex I subject to the following provisions:

- (1) at least 50 % of the total nitrogen content of the fertiliser consists of the nitrogen forms specified in column 3;
- (2) they do not belong to the fertiliser types mentioned in column 4.

Fertilisers to which a nitrification inhibitor listed in Table F.1. has been added shall have the words 'with nitrification inhibitor ([type designation of nitrification inhibitor])' added to their type designation.

Fertilisers to which a urease inhibitor listed in Table F.2. has been added shall have the words 'with urease inhibitor ([type designation of urease inhibitor])' added to their type designation.

Technical information, as complete as possible, must be provided with each package or bulk consignment by the person responsible for marketing. This information must enable the user in particular to determine the rates and timing of application in relation to the crop being grown.

⁽¹⁾ The complexing agents are to be identified by the European Standards that cover the mentioned complexing agents.

▼ M5

New nitrification inhibitors or urease inhibitors may be included in the Tables F1 or F2 respectively after evaluation of the technical files submitted in accordance with guidelines to be elaborated for these compounds.

F.1. *Nitrification inhibitors*

No	Type designation and composition of the nitrification inhibitor	Minimum and maximum inhibitor content as a percentage by mass of the total nitrogen present as ammonium nitrogen and urea nitrogen.	EC fertiliser types for which the inhibitor may not be used	Description of nitrification inhibitors with which mixtures are allowed Data on permitted ratio
1	2	3	4	5
1	Dicyandiamide ELINCS No 207-312-8	Minimum 2,25 Maximum 4,5		
2	Product containing dicyandiamide (DCD) and 1,2,4-triazole (TZ) EC# EINECS No 207-312-8 EC# EINECS No 206-022-9	Minimum 2,0 Maximum 4,0		Mixture ratio 10:1 (DCD:TZ)
3	Product containing 1,2,4-triazole (TZ) and 3-methylpyrazole (MP) EC# EINECS No 206-022-9 EC# EINECS No 215-925-7	Minimum 0,2 Maximum 1,0		Mixture ratio 2:1 (TZ:MP)

▼ M9**▼ M5**F.2. *Urease inhibitors*

No	Type designation and composition of the urease inhibitor	Minimum and maximum inhibitor content as a percentage by mass of the total nitrogen present as urea nitrogen	EC fertiliser types for which the inhibitor may not be used	Description of urease inhibitors with which mixtures are allowed Data on permitted ratio
1	2	3	4	5
1	N-(n-butyl) thiophosphoric triamide (NBPT) ELINCS No 435-740-7	Minimum 0,09 Maximum 0,20		
2	N-(2-nitrophenyl)phosphoric triamide (2-NPT) EC# EINECS No 477-690-9	Minimum 0,04 Maximum 0,15		

▼ M9



ANNEX II

TOLERANCES

The tolerances given in this Annex are negative values in percentage by mass.

The tolerance allowed in respect of the declared nutrient contents in the various types of EC fertiliser are as follows:

1. **Inorganic straight primary nutrient fertilisers absolute value in percentage by mass expressed as N, P₂O₅, K₂O, MgO, Cl**

1.1. *Nitrogenous fertilisers*

calcium nitrate	0,4
calcium — magnesium nitrate	0,4
sodium nitrate	0,4
chile nitrate	0,4
calcium cyanamide	1,0
nitrogenous calcium cyanamide	1,0
ammonium sulphate	0,3
Ammonium nitrate or calcium ammonium nitrate:	
— up to and including 32 %	0,8
— more than 32 %	0,6
ammonium sulphate-nitrate	0,8
magnesium sulphonitrate	0,8
magnesium ammonium nitrate	0,8
urea	0,4
calcium nitrate suspension	0,4
nitrogen fertiliser solution with urea formaldehyde	0,4
nitrogen fertiliser suspension with urea formaldehyde	0,4
urea-ammonium sulphate	0,5
nitrogen fertiliser solution	0,6
ammonium nitrate-urea solution	0,6

1.2. *Phosphatic fertilisers*

Thomas slag:

— declaration expressed as a range of 2 % by mass	0,0
— declaration expressed as a single number	1,0

Other phosphatic fertilisers

P ₂ O ₅ solubility in:	(number of fertiliser in Annex I)	
— mineral acid	(3, 6, 7)	0,8
— formic acid	(7)	0,8
— neutral ammonium citrate	(2a, 2b, 2c)	0,8
— alkaline ammonium citrate	(4, 5, 6)	0,8
— water	(2a, 2b, 3)	0,9
	(2c)	1,3

▼B1.3. *Potassic fertilisers*

kainit	1,5
enriched kainit salt	1,0
muriate of potash:	
— up to and including 55 %	1,0
— more than 55 %	0,5
potassium chloride containing magnesium salt	1,5
sulphate of potash	0,5
sulphate of potash containing magnesium salt	1,5

1.4. *Other components*

chloride	0,2
----------	-----

2. Inorganic compound primary nutrient fertilisers2.1. *Nutrient elements*

N	1,1
P ₂ O ₅	1,1
K ₂ O	1,1

2.2. *Total negative deviations from the declared value*

binary fertilisers	1,5
ternary fertilisers	1,9

3. Secondary nutrients in fertilisers

The tolerances allowed in respect of the declared calcium, magnesium, sodium and sulphur contents shall be a quarter of the declared contents of these nutrients up to a maximum of 0,9 % in absolute terms for CaO, MgO, Na₂O, and SO₃, i.e. 0,64 for Ca, 0,55 for Mg, 0,67 for Na and 0,36 for S.

4. Micro-nutrients in fertilisers

The tolerance allowed in respect of the declared micro-nutrient content shall be:

- 0,4 % in absolute terms for a content of more than 2 %,
- one fifth of the declared value for a content not exceeding 2 %.

The tolerance allowed in respect of the declared content for the various forms of nitrogen or the declared solubilities of phosphorus pentoxide is one-tenth of the overall content of the nutrient concerned with a maximum of 2 % by mass, provided that the overall content of that nutrient remains within the limits specified in Annex I and the tolerances specified above.



ANNEX III

TECHNICAL PROVISIONS FOR AMMONIUM NITRATE FERTILISERS OF HIGH NITROGEN CONTENT

1. Characteristics of and limits for straight ammonium nitrate fertilisers of high nitrogen content

1.1. *Porosity (oil retention)*

The oil retention of the fertiliser, which must first have undergone two thermal cycles of a temperature ranging from 25 to 50 °C and conforming with the provisions of part 2 of section 3. of this Annex, must not exceed 4 % by mass.

1.2. *Combustible ingredients*

The percentage by mass of combustible material measured as carbon must not exceed 0,2 % for fertilisers having a nitrogen content of at least 31,5 % by mass and must not exceed 0,4 % for fertilisers having a nitrogen content of at least 28 % but less than 31,5 % by mass.

1.3. *pH*

A solution of 10 g of fertiliser in 100 ml of water must have a pH of at least 4.5.

1.4. *Particle size analysis*

Not more than 5 % by mass of the fertiliser must pass through a 1 mm mesh sieve and not more than 3 % by mass must pass through a 0,5 mm mesh sieve.

1.5. *Chlorine*

The maximum chlorine content is set at 0,02 % by mass.

1.6. *Heavy metals*

Heavy metals should not be added deliberately, and any traces which are incidental to the production process should not exceed the limit fixed by the Committee.

The copper content shall not be higher than 10 mg/kg.

No limits are specified for other heavy metals.

2. Description of the test of resistance to detonation concerning ammonium nitrate fertilisers of high nitrogen content

The test must be carried out on a representative sample of fertiliser. Before being tested for resistance to detonation, the whole mass of the sample is to be thermally cycled five times complying with the provisions of part 3 in section 3. of this Annex.

The fertiliser must be subjected to the test of resistance to detonation in a horizontal steel tube under the following conditions:

— seamless steel tube,

— Tube length: 1 000 mm at least,

— Nominal external diameter: 114 mm at least,

— Nominal wall thickness: 5 mm at least,

— Booster: the type and mass of the booster chosen should be such as to maximise the detonation pressure applied to the sample in order to determine its susceptibility to the transmission of detonation,

— Test temperature: 15-25 °C,

▼B

- Witness lead cylinders for detecting detonation: 50 mm diameter and 100 mm high
- placed at 150 mm intervals and supporting the tube horizontally. The test is to be carried out twice. The test is deemed conclusive if in both tests one or more of the supporting lead cylinders is crushed by less than 5 %.

3. **Methods of checking compliance with the limits specified in Annexes III-1 and III-2**

Method 1

Methods for the application of thermal cycles

1. **Scope and field of application**

This document defines the procedures for the application of thermal cycles prior to the execution of the oil retention test for straight ammonium nitrate fertilisers of high nitrogen content and of the test on the resistance to detonation for both, straight and compound ammonium nitrate fertiliser of high nitrogen content.

The methods of the closed thermal cycles as described in this section are regarded as simulating sufficiently the conditions to be taken into account within the scope of application of title II, chapter IV, however, these methods may not necessarily simulate all conditions arising during transport and storage;

2. **Thermal cycles referred to in Annex III-1**

2.1. *Field of application*

This procedure is for thermal cycling prior to determining the oil retention of the fertiliser.

2.2. *Principle and definition*

In an Erlenmeyer flask, heat the sample from ambient temperature to 50 °C and maintain at this temperature for a period of two hours (phase at 50 °C). Thereupon cool the sample until a temperature of 25 °C is achieved and maintain at that temperature for two hours (phase at 25 °C). The combination of the successive phases at 50 °C and 25 °C forms one thermal cycle. After being subjected to two thermal cycles, the test sample is held at a temperature of 20 ± 3 °C for the determination of the oil retention value.

2.3. *Apparatus*

Normal laboratory apparatus, in particular:

- water baths thermostated at $25 (\pm 1)$ and $50 (\pm 1)$ °C respectively,
- Erlenmeyer flasks with an individual capacity of 150 ml.

2.4. *Procedure*

Put each test sample of $70 (\pm 5)$ grams into an Erlenmeyer flask which is then sealed with a stopper.

Move each flask every two hours from the 50 °C bath to the 25 °C bath and vice versa.

Maintain the water in each bath at constant temperature and keep in motion by rapid stirring to ensure the water level comes above the level of the sample. Protect the stopper from condensation by a foam rubber cap.

3. **Thermal cycles to be used for Annex III-2**

3.1. *Field of application*

This procedure is for thermal cycling prior to the execution of the detonability test.

▼B

3.2. *Principle and definition*

In a watertight box heat the sample from ambient temperature to 50 °C and maintain at this temperature for a period of one hour (phase at 50 °C). Thereupon cool the sample until a temperature of 25 °C is achieved and maintain at that temperature for one hour (phase at 25 °C). The combination of the successive phases at 50 °C and 25 °C forms one thermal cycle. After being subjected to the required number of thermal cycles, the test sample is held at a temperature of 20 ± 3 °C pending the execution of the detonability test.

3.3. *Apparatus*

- A water bath, thermostated in a temperature range of 20 to 51 °C with a minimum heating and cooling rate of 10 °C/h, or two water baths, one thermostated at a temperature of 20 °C, the other at 51 °C. The water in the bath(s) is continuously stirred; the volume of the bath should be large enough to guarantee ample circulation of the water.
- A stainless steel box, watertight all around and provided with a thermocouple in the centre. The outside width of the box is $45 (\pm 2)$ mm and the wall thickness is 1,5 mm (see Figure 1). The height and length of the box can be chosen to suit the dimensions of the water bath, e.g. length 600 mm, height 400 mm.

3.4. *Procedure*

Place a quantity of fertilisers sufficient for a single detonation into the box and close the cover. Place the box in the water bath. Heat the water to 51 °C and measure the temperature in the centre of the fertiliser. One hour after the temperature at the centre has reached 50 °C cool the water. One hour after the temperature at the centre has reached 25 °C heat the water to start the second cycle. In the case of two water baths, transfer the box to the other bath after each heating/cooling period.

Figure 1

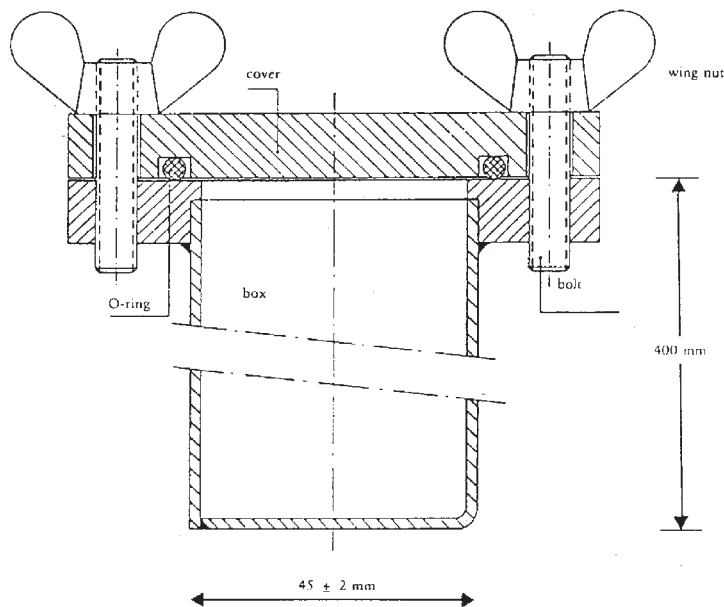

▼B

Method 2

Determination of oil retention**1. Scope and field of application**

This document defines the procedure for the determination of oil retention of straight ammonium nitrate fertilisers of high nitrogen content.

The method is applicable to both prilled and granular fertilisers which do not contain oil-soluble materials.

2. Definition

Oil retention of a fertiliser: the quantity of oil retained by the fertiliser determined under the operating conditions specified, and expressed as a percentage by mass.

3. Principle

Total immersion of the test portion in gas oil for a specified period, followed by the draining away of surplus oil under specified conditions. Measurement of the increase in mass of the test portion.

4. Reagent

Gas oil

Viscosity max.: 5 mPas at 40 °C

Density: 0,8 to 0,85 g/ml at 20 °C

Sulphur content: ≤ 1,0 % (m/m)

Ash: ≤ 0,1 % (m/m)

5. Apparatus

Ordinary laboratory apparatus, and:

5.1. Balance, capable of weighing to the nearest 0,01 gram.

5.2. Beakers, of capacity 500 ml.

5.3. Funnel, of plastic materials, preferably with a cylindrical wall at the upper end, diameter approximately 200 mm.

5.4. Test sieve, aperture 0,5 mm, fitting into the funnel (5.3).

Note: The size of the funnel and sieve is such as to ensure that only a few granules lie one above another and the oil is able to drain easily.

5.5. Filter paper, rapid filtering grade, creped, soft, mass 150 g/m².

5.6. Absorbent tissue (laboratory grade).

6. Procedure

6.1. Two individual determinations are carried out in quick succession on separate portions of the same test sample.

▼ M7

- 6.2. Remove particles smaller than 0,5 mm using the test sieve (5.4). Weigh to the nearest 0,01 gram approximately 50 grams of the sample into the beaker (5.2). Add sufficient gas oil (section 4) to cover the prills or granules completely and stir carefully to ensure that the surfaces of all the prills or granules are fully wetted. Cover the beaker with a watch glass and leave to stand for one hour at 25 (± 2) °C.

▼ B

- 6.3. Filter the entire contents of the beaker through the funnel (5.3) containing the test sieve (5.4). Allow the portion retained by the sieve to remain there for one hour so that most of the excess oil can drain away.

- 6.4. Lay two sheets of filter paper (5.5) (about 500 × 500 mm) on top of each other on a smooth surface; fold the four edges of both filter papers upwards to a width of about 40 mm to prevent the prills from rolling away. Place two layers of absorbent tissue (5.6) in the centre of the filter papers. Pour the entire contents of the sieve (5.4) over the absorbent tissues and spread the prills evenly with a soft, flat brush. After two minutes lift one side of the tissues to transfer the prills to the filter papers beneath and spread them evenly over these with the brush. Lay another sheet of filter paper, similarly with its edges turned upward, on the sample and roll the prills between the filter papers with circular movements while exerting a little pressure. Pause after every eight circular movements to lift the opposite edges of the filter papers and return to the centre the prills that have rolled to the periphery. Keep to the following procedure: make four complete circular movements, first clockwise and then anticlockwise. Then roll the prills back to the centre as described above. This procedure to be carried out three times (24 circular movements, edges lifted twice). Carefully insert a new sheet of filter paper between the bottom sheet and the one above it and allow the prills to roll onto the new sheet by lifting the edges of the upper sheet. Cover the prills with a new sheet of filter paper and repeat the same procedure as described above. Immediately after rolling, pour the prills into a tared dish and reweigh to the nearest 0,01 gram to determine the mass of the quantity of gas oil retained.

- 6.5. *Repeating the rolling procedure and reweighing*

If the quantity of gas oil retained in the portion is found to be greater than 2 grams, place the portion on a fresh set of filter papers and repeat the rolling procedure, lifting the corners in accordance with section 6.4 (two times eight circular movements, lifting once). Then reweigh the portion.

7. **Expression of the results**

- 7.1. *Method of calculation and formula*

The oil retention, from each determination (6.1) expressed as a percentage by mass of the sieved test portion, is given by the equation:

$$\text{Oil retention} = \frac{m_2 - m_1}{m_1} \times 100$$

where:

m_1 is the mass, in grams, of the sieved test portion (6.2),

▼B

m_2 is the mass, in grams, of the test portion according to section 6.4 or 6.5 respectively as the result of the last weighing.

Take as the result the arithmetic mean of the two individual determinations.

Method 3

Determination of the combustible ingredients**1. Scope and field of application**

This document defines the procedure for the determination of the combustible content of straight ammonium nitrate fertilisers of high nitrogen content.

2. Principle

The carbon dioxide produced by inorganic fillers is removed in advance with an acid. The organic compounds are oxidised by means of a chromic acid/sulphuric acid mixture. Carbon dioxide formed is absorbed in a barium hydroxide solution. The precipitate is dissolved in a solution of hydrochloric acid and measured by back-titration with sodium hydroxide solution.

3. Reagents

- 3.1. Analytical-grade chromium (VI) trioxide Cr_2O_3 ;
- 3.2. Sulphuric acid, 60 % by volume: pour 360 ml of water into a one-litre beaker and carefully add 640 ml of sulphuric acid (density at 20 °C = 1.83 g/ml).
- 3.3. Silver nitrate: 0,1 mol/l solution.
- 3.4. *Barium hydroxide*
Weigh out 15 grams of barium hydroxide [$\text{Ba}(\text{OH})_2 \cdot 8\text{H}_2\text{O}$], and dissolve completely in hot water. Allow to cool and transfer to a one-litre flask. Fill up to the mark and mix. Filter through a pleated filter paper.
- 3.5. Hydrochloric acid: 0,1 mol/l standard solution.
- 3.6. Sodium hydroxide: 0,1 mol/l standard solution.
- 3.7. Bromophenol blue: solution of 0,4 grams per litre in water.
- 3.8. Phenolphthalein: solution of 2 grams per litre in 60 % by volume ethanol.
- 3.9. Soda lime: particle dimensions, about 1,0 to 1,5 mm.
- 3.10. Demineralised water, freshly boiled to remove carbon dioxide.

4. Apparatus

- 4.1. *Standard laboratory equipment, in particular:*
 - filter crucible with a plate of sintered glass and a capacity of 15 ml; plate diameter: 20 mm; total height: 50 mm; porosity 4 (pore diameter from 5 to 15 μm),
 - 600-ml beaker.
- 4.2. Compressed nitrogen supply.
- 4.3. Apparatus made up of the following parts and assembled, if possible, by means of spherical ground joints (*see Figure 2*).
 - 4.3.1. Absorption tube A about 200 mm long and 30 mm in diameter filled with soda lime (3.9) kept in place by fibreglass plugs.

▼B

- 4.3.2. 500-ml reaction flask B with side arm and a round bottom.
- 4.3.3. Vigreux fractionating column about 150 mm long (C').
- 4.3.4. Double-surface condenser C, 200 mm long.

▼M7

- 4.3.5. Dreschel bottle D acting as a trap for any excess of acid which may distil over.

▼B

- 4.3.6. Ice bath E to cool the Drechsel bottle.
- 4.3.7. Two absorption vessels F_1 and F_2 , 32 to 35 mm in diameter, the gas distributor of which comprises a 10 mm disc of low-porosity sintered glass.
- 4.3.8. Suction pump and suction regulating device G comprising a T-shaped glass piece inserted into the circuit, the free arm of which is connected to the fine capillary tube by a short rubber tube fitted with a screw clamp.

Caution: The use of boiling chromic acid solution in an apparatus under reduced pressure is a hazardous operation and requires appropriate precautions.

5. **Procedure**5.1. *Sample for analysis*

Weigh approximately 10 grams of ammonium nitrate to the nearest 0,001 grams.

5.2. *Removal of carbonates***▼M7**

Place the sample for analysis in the reaction flask B. Add 100 ml of H_2SO_4 (3.2). The prills or granules dissolve in about 10 minutes at ambient temperature. Assemble the apparatus as indicated in the diagram: connect one end of the absorption tube (A) to the nitrogen source (4.2) via a non-return flow device containing a pressure of 667 to 800 Pa and the other end to the feed tube which enters the reaction flask. Place the Vigreux fractionating column (C') and the condenser (C) with cooling water supply in position. Adjust the nitrogen to provide a moderate flow through the solution, bring the solution to boiling point and heat for two minutes. At the end of this time there should be no more effervescence. If effervescence is seen, continue heating for 30 minutes. Allow solution to cool for at least 20 minutes with the nitrogen flowing through it.

▼B

Complete assembly of the apparatus as indicated in the diagram by connecting the condenser tube to the Drechsel bottle (D) and the bottle to the absorption vessels F_1 and F_2 . The nitrogen must continue to pass through the solution during the assembly operation. Rapidly introduce 50 ml of barium hydroxide solution (3.4) into each of the absorption vessels (F_1 and F_2).

Bubble a stream of nitrogen through for about 10 minutes. The solution must remain clear in the absorbers. If this does not happen, the carbonate removal process must be repeated.

5.3. *Oxidation and absorption*

After withdrawing the nitrogen feed tube, rapidly introduce 20 grams of chromium trioxide (3.1) and 6 ml of silver nitrate solution (3.3) via the side arm of the reaction flask (B). Connect the apparatus to the suction pump and adjust the nitrogen flow so that a steady stream of gas bubbles passes through the sintered-glass absorbers F_1 and F_2 .

▼ B

Heat the reaction flask (B) until the liquid boils and keep it boiling for one and a half hours⁽¹⁾. It may be necessary to adjust the suction-regulating valve (G) to control the nitrogen flow since it is possible that the barium carbonate precipitated during the test may block the sintered-glass discs. The operation is satisfactory when the barium hydroxide solution in the absorber F₂ remains clear. Otherwise repeat the test. Stop heating and dismantle the apparatus. Wash each of the distributors (3.10) both inside and outside to remove barium hydroxide and collect the washings in the corresponding absorber. Place the distributors one after the other in a 600-ml beaker which will subsequently be used for the determination.

Rapidly filter under vacuum firstly the contents of absorber F₂ and then of absorber F₁ using the sintered-glass crucible. Collect the precipitate by rinsing the absorbers with water (3.10) and wash the crucible with 50 ml of the same water. Place the crucible in the 600-ml beaker and add about 100 ml of boiled water (3.10). Introduce 50 ml of boiled water into each of the absorbers and pass nitrogen through the distributors for five minutes. Combine the water with that from the beaker. Repeat the operation once to ensure that the distributors are rinsed thoroughly.

5.4. *Measurement of the carbonates originating from organic material*

Add five drops of phenolphthalein (3.8) to the contents of the beaker. The solution becomes red in colour. Add hydrochloric acid (3.5) drop by drop until the pink colour just disappears. Stir the solution well in the crucible to check that the pink colour does not reappear. Add five drops of bromphenol blue (3.7) and titrate with hydrochloric acid (3.5) until the solution turns yellow. Add a further 10 ml of hydrochloric acid.

Heat the solution to boiling point and continue boiling for a maximum of one minute. Check carefully that no precipitate remains in the liquid.

Allow to cool and back titrate with the sodium hydroxide solution (3.6).

6. **Blank test**

Carry out a blank test following the same procedure and using the same quantities of all reagents.

7. **Expression of the results**

The content of combustible ingredients (C), expressed as carbon, as a percentage by mass of the sample, is given by the formula:

$$C \% = 0,0 \times \frac{V_1 - V_2}{E}$$

where:

E = the mass in grams of the test portion,

V₁ = the total volume in ml of 0,1 mol/l hydrochloric acid added after the change in colour of the phenolphthalein,

V₂ = the volume in ml of the 0,1 mol/l sodium hydroxide solution used for back titration.

⁽¹⁾ A reaction time of one and a half hours, is sufficient in the case of most of the organic substances in the presence of silver nitrate catalyst.



Figure 2

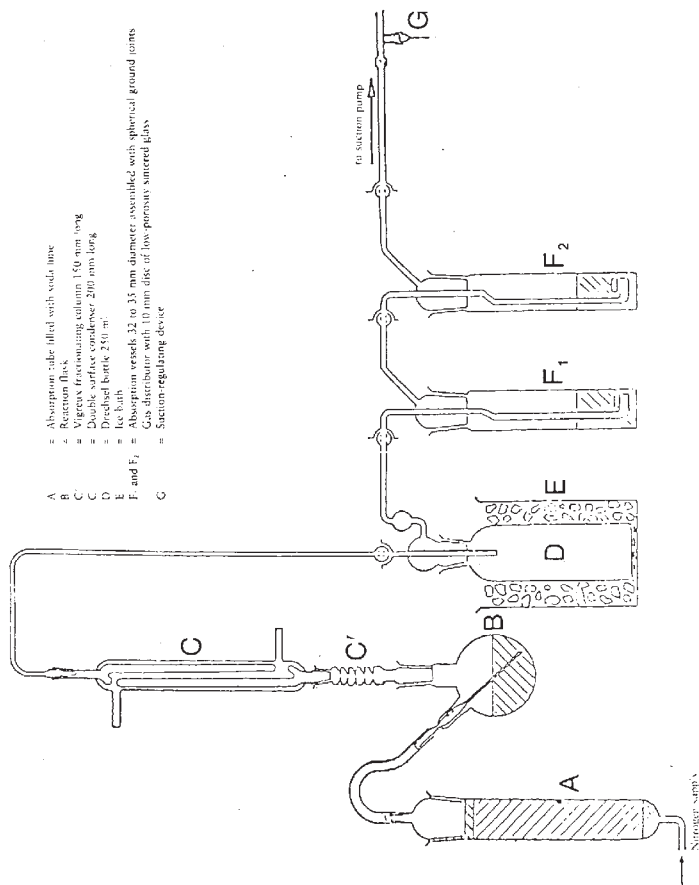

Method 4

Determination of the pH value

1. Scope and field of application

This document defines the procedure for measuring the pH value of a solution of a straight ammonium nitrate fertiliser of high nitrogen content.

2. Principle

Measurement of the pH of an ammonium nitrate solution by means of a pH meter.

3. Reagents

Distilled or demineralised water, free from carbon dioxide.

3.1. Buffer solution, pH 6,88 at 20 °C

Dissolve $3,40 \pm 0,01$ grams of potassium dihydrogen orthophosphate (KH_2PO_4) in approximately 400 ml of water. Then dissolve $3,55 \pm 0,01$ grams of disodium hydrogen orthophosphate (Na_2HPO_4) in approximately 400 ml of water. Transfer the two solutions without loss into a 1 000-ml graduated flask, make up to the mark and mix. Keep this solution in an airtight vessel.

▼B

- 3.2. *Buffer solution, pH 4,00 at 20 °C*
- Dissolve $10,21 \pm 0,01$ grams of potassium hydrogen phthalate ($\text{KHC}_8\text{O}_4\text{H}_4$) in water, transfer without loss into a 1 000-ml graduated flask, make up to the mark and mix.
- Keep this solution in an airtight vessel.
- 3.3. Commercially available pH standard solutions may be used.
4. **Apparatus**
- pH meter, equipped with glass and calomel electrodes or equivalent, sensitivity 0,05 pH unit.
5. **Procedure**
- 5.1. *Calibration of the pH meter*
- Calibrate the pH meter (4) at a temperature of $20 (\pm 1) ^\circ\text{C}$, using the buffer solutions (3.1), (3.2) or (3.3). Pass a slow stream of nitrogen onto the surface of the solution and maintain this throughout the test.
- 5.2. *Determination*
- Pour 100,0 ml of water onto $10 (\pm 0,01)$ grams of the sample in a 250 ml beaker. Remove the insolubles by filtering, decanting or centrifuging the liquid. Measure the pH value of the clear solution at a temperature of $20 (\pm 1) ^\circ\text{C}$ according to the same procedure as for the calibration of the meter.
6. **Expression of the results**
- Express the result in pH units, to the nearest 0,1 unit, and state the temperature used.

Method 5**Determination of the particle size**

1. **Scope and field of application**
- This document defines the procedure for the test sieving of straight ammonium nitrate fertilisers of high nitrogen content.
2. **Principle**
- The test sample is sieved on a nest of three sieves, either by hand or by mechanical means. The mass retained on each sieve is recorded and the percentage of material passing the required sieves are calculated.
3. **Apparatus**
- 3.1. 200-mm-diameter woven-wire test sieves with apertures of 2,0 mm, 1,0 mm and 0,5 mm respectively of standard ranges. One lid and one receiver for these sieves.
- 3.2. Balance to weigh to 0,1 gram.
- 3.3. Mechanical sieve shaker (if available) capable of imparting both vertical and horizontal motion to the test sample.
4. **Procedure**
- 4.1. The sample is divided representatively into portions of approximately 100 grams.
- 4.2. Weigh one of these portions to the nearest 0,1 gram.

▼B

- 4.3. Arrange the nest of sieves in ascending order; receiver, 0,5 mm, 1 mm, 2 mm and place the weighed test portion on the top sieve. Fit the lid to the top of the nest of sieves.
- 4.4. Shake by hand or machine, imparting both a vertical and horizontal motion and if by hand, tapping occasionally. Continue this process for 10 minutes or until the quantity passing through each sieve in one minute is less than 0,1 gram.
- 4.5. Remove the sieves from the nest in turn and collect the material retained, brush gently from the reverse side with a soft brush, if necessary.
- 4.6. Weigh the material retained on each sieve and that collected in the receiver, to the nearest 0,1 gram.
5. **Evaluation of the results**
 - 5.1. Convert the fraction masses to a percentage of the total of the fraction masses (not of the original charge).

Calculate the percentage in the receiver (i.e. < 0,5 mm): A %

Calculate the percentage retained on the 0,5 mm sieve: B %

Calculate the percentage passing 1,0 mm, i.e. (A + B) %

The sum of the fraction masses should be within 2 % of the initial mass taken.
 - 5.2. At least two separate analyses should be carried out and the individual results for A should not differ by more than 1,0 % absolute and for B by more than 1,5 % absolute. Repeat the test if this is not the case.
6. **Expression of the results**

Report the mean of the two values obtained for A on the one hand and for A + B on the other.

Method 6**Determination of the chlorine content (as chloride ion)**

1. **Scope and field of application**

This document defines the procedure for the determination of the chlorine content (as chloride ion) of straight ammonium nitrate fertilisers with a high nitrogen content.
2. **Principle**

Chloride ions dissolved in water are determined by potentiometric titration with silver nitrate in an acidic medium.
3. **Reagents**

Distilled or demineralised water, free from chloride ions.

 - 3.1. Acetone AR.
 - 3.2. Concentrated nitric acid (density at 20 °C = 1,40 g/ml)
 - 3.3. Silver nitrate 0,1 mol/l standard solution. Store this solution in a brown glass bottle.
 - 3.4. Silver nitrate 0,004 mol/l standard solution - prepare this solution at the time of use.

▼B

- 3.5. Potassium chloride 0,1 mol/l standard reference solution. Weigh, to the nearest 0,1 mg, 3,7276 grams of analytical-grade potassium chloride, previously dried for one hour in an oven at 130 °C and cooled in a desiccator to ambient temperature. Dissolve in a little water, transfer the solution without loss into a 500-ml standard flask, dilute to the mark and mix.
- 3.6. Potassium chloride, 0,004 mol/l standard reference solution — prepare this solution at the time of use.

4. Apparatus

- 4.1. Potentiometer with silver indicating electrode and calomel reference electrode, sensitivity 2 mV, covering the range - 500 to + 500 mV.
- 4.2. Bridge, containing a saturated potassium nitrate solution, connected to the calomel electrode (4.1), fitted at the ends with porous plugs.
- 4.3. Magnetic stirrer, with a Teflon-coated rod.
- 4.4. Microburette with fine-pointed tip, graduated in 0,01 ml divisions.

5. Procedure**5.1. Standardisation of the silver nitrate solution**

Take 5,00 ml and 10,00 ml of the standard reference potassium chloride solution (3.6) and place in two low-form beakers of convenient capacity (for example 250 ml). Carry out the following titration of the contents of each beaker.

Add 5 ml of the nitric acid solution (3.2), 120 ml of the acetone (3.1) and sufficient water to bring the total volume to about 150 ml. Place the rod of the magnetic stirrer (4.3) in the beaker and set the stirrer in motion. Immerse the silver electrode (4.1) and the free end of the bridge (4.2) in the solution. Connect the electrodes to the potentiometer (4.1) and, after verifying the zero of the apparatus, note the value of the starting potential.

Titrate, using the microburette (4.4), adding initially 4 or 9 ml respectively of the silver nitrate solution corresponding to the standard reference potassium chloride solution used. Continue the addition in 0,1 ml portions for the 0,004 mol/l solutions and in 0,05 ml portions for the 0,1 mol/l solutions. After each addition, await the stabilisation of the potential.

Record the volumes added and the corresponding values of the potential in the first two columns of a table.

In a third column of the table, record the successive increments (Δ_1E) of the potential E . In a fourth column, record the differences (Δ_2E) positive or negative, between the potential increments (Δ_1E). The end of the titration corresponds to the addition of the 0,1 or 0,05 ml portion (V_1) of the silver nitrate solution which gives the maximum value of Δ_1E .

In order to calculate the exact volume (V_{eq}) of the silver nitrate solution corresponding to the end of the reaction, use the formula:

$$V_{eq} = V_0 + \left(V_1 \times \frac{b}{B} \right)$$

where:

V_0 is the total volume, in ml, of the silver nitrate solution immediately lower than the volume which gives the maximum increment of Δ_1E ,

V_1 is the volume, in ml, of the last portion of the silver nitrate solution added (0,1 or 0,05 ml),

▼B

b is the last positive value of Δ_2E ,

B is the sum of the absolute values of the last positive values of Δ_2E and the first negative value of Δ_2E (see example in Table 1).

5.2. *Blank test*

Carry out a blank test and take account thereof when calculating the final result.

The result V_4 of the blank test on the reagents is given, in ml, by the formula:

$$V_4 = 2V_3 - V_2$$

where:

V_2 is the value, in ml, of the exact volume (V_{eq}) of the silver nitrate solution corresponding to the titration of 10 ml of the potassium chloride standard reference solution used,

V_3 is the value, in ml, of the exact volume (V_{eq}) of the silver nitrate solution corresponding to the titration of 5 ml of the potassium chloride standard reference solution used.

5.3. *Check test*

The blank test can at the same time serve as a check that the apparatus is functioning satisfactorily and that the test procedure is being implemented correctly.

5.4. *Determination*

Take a portion of sample in the range 10 to 20 grams and weigh to the nearest 0,01 gram. Transfer quantitatively to a 250-ml beaker. Add 20 ml of water, 5 ml of nitric acid solution (3.2), 120 ml of acetone (3.1) and sufficient water to bring the total volume to about 150 ml.

Place the rod of the magnetic stirrer (4.3) in the beaker, place the beaker on the stirrer and set the stirrer in motion. Immerse the silver electrode (4.1) and the free end of the bridge (4.2) in the solution, connect the electrodes to the potentiometer (4.1) and, after having verified the zero of the apparatus, note the value of the starting potential.

Titrate with the silver nitrate solution, by additions from the micro-burette (4.4) in increments of 0,1 ml. After each addition, await the stabilisation of the potential.

Continue the titration as specified in 5.1, starting from the fourth paragraph: 'Record the volumes added and the corresponding values of the potential in the first two columns of a table ...'.

6. **Expression of the results**

Express the result of the analysis as the percentage of chlorine contained in the sample as received for analysis. Calculate the percentage of chlorine (Cl) content from the formula:

$$\text{Cl \%} = \frac{0,3545 \times T \times (V_5 - V_4) \times 100}{m}$$

where:

T is the concentration of silver nitrate solution used, in mol/l

V_4 is the result, in ml, of the blank test (5.2),

▼ B

V_5 is the value, in ml, of V_{eq} corresponding to the determination (5.4),
 m is the mass, in grams, of the test portion.

Table 1: Example

Volume of the silver nitrate solution V (ml)	Potential E (mV)	$\Delta_1 E$	$\Delta_2 E$
4,80	176		
4,90	211	35	+ 37
5,00	283	72	- 49
5,10	306	23	- 10
5,20	319	13	

$$V_{eq} = 4,9 + 0,1 \times \frac{37}{37 + 49} = 4,943$$

Method 7**Determination of copper****1. Scope and field of application**

This document defines the procedure for the determination of copper content of straight ammonium nitrate fertilisers of high nitrogen content.

2. Principle

The sample is dissolved in dilute hydrochloric acid and the copper is determined by atomic absorption spectrophotometry.

3. Reagents

- 3.1. Hydrochloric acid (density at 20 °C = 1,18 g/ml).
- 3.2. Hydrochloric acid, 6 mol/l solution.
- 3.3. Hydrochloric acid 0,5 mol/l solution.
- 3.4. Ammonium nitrate.
- 3.5. Hydrogen peroxide, 30 % w/v
- 3.6. Copper solution ⁽¹⁾ (stock): weigh, to the nearest 0,001 gram, 1 gram of pure copper, dissolve in 25 ml 6 mol/l hydrochloric acid solution (3.2), add 5 ml of hydrogen peroxide (3.5) in portions and dilute to 1 litre with water. 1 ml of this solution contains 1 000 µg of copper (Cu).
- 3.6.1. Copper solution (dilute): dilute 10 ml of stock solution (3.6) to 100 ml with water and then dilute 10 ml of the resulting solution, to 100 ml with water, 1 ml of the final dilution contains 10 µg of copper (Cu).

Prepare this solution at the time of use.

4. Apparatus

Atomic absorption spectrophotometer with a copper lamp (324,8 nm).

5. Procedure**5.1. Preparation of the solution for analysis**

Weigh, to the nearest 0,001 gram, 25 grams of the sample, place it in a 400-ml beaker, add carefully 20 ml of hydrochloric acid (3.1) (there may be a vigorous reaction due to carbon dioxide formation). Add more hydrochloric acid, if necessary. When effervescence has stopped,

⁽¹⁾ Commercially available standard copper solution may be used.

▼B

evaporate to dryness on a steam bath, stirring occasionally with a glass rod. Add 15 ml 6 mol/l hydrochloric acid solution (3.2) and 120 ml of water. Stir with the glass rod, which should be left in the beaker, and cover the beaker with a watch glass. Boil the solution gently until dissolution is complete and then cool.

Transfer the solution quantitatively into a 250-ml graduated flask, by washing the beaker with 5 ml 6 mol/l hydrochloric acid (3.2), and twice with 5 ml of boiling water, make up to the mark with 0,5 mol/l hydrochloric acid (3.3) and mix carefully.

Filter through a copper-free filter paper ⁽¹⁾, discarding the first 50 ml.

5.2. Blank solution

Prepare a blank solution from which only the sample has been omitted and allow for this in the calculation of the final results.

5.3. Determination**5.3.1. Preparation of sample and blank test solutions**

Dilute the sample solution (5.1) and the blank test solution (5.2) with 0,5 mol/l hydrochloric acid solution (3.3) to a concentration of copper within the optimal measuring range of the spectrophotometer. Normally no dilution is needed.

5.3.2. Preparation of the calibration solutions

By diluting the standard solution (3.6.1) with 0,5 mol/l hydrochloric acid solution (3.3), prepare at least five standard solutions corresponding to the optimal measuring range of the spectrophotometer (0 to 5,0 mg/l Cu). Before making up to the mark, add to every solution ammonium nitrate (3.4) to give concentration of 100 mg per ml.

5.4. Measurement

Set up the spectrophotometer (4) at a wavelength of 324,8 nm. Use an oxidising air-acetylene flame. Spray successively, in triplicate, the calibration solution (5.3.2), the sample solution and the blank solution (5.3.1), washing the instrument through with distilled water between each spraying. Plot the calibration curve using the mean absorbances of every standard used as the ordinates and the corresponding concentrations of copper in µg/ml as the abscissae.

Determine the concentration of copper in the final sample and blank solutions by reference to the calibration curve.

6. Expression of the results

Calculate the copper content of the sample taking into account the mass of the test sample, the dilutions carried out in the course of the analysis and the value of the blank. Express the result as mg Cu/kg.

4. Determination of resistance to detonation**4.1. Scope and field of application**

This document defines the procedure for the determination or resistance to detonation of ammonium nitrate fertilisers of high nitrogen content.

⁽¹⁾ Whatman 541 or equivalent.

▼ B4.2. *Principle*

The test sample is confined in a steel tube and subjected to detonation shock from an explosive booster charge. Propagation of the detonation is determined from the degree of crushing of lead cylinders on which the tube rests horizontally during the test.

4.3. *Materials*

4.3.1. Plastic explosive containing 83 to 86 % penthrite

Density: 1 500 to 1 600 kg/m³

Detonation velocity: 7 300 to 7 700 m/s

Mass: 500 (± 1) gram.

4.3.2. Seven lengths of flexible detonating cord with non-metallic sleeve

Filling mass: 11 to 13 g/m

Length of each cord: 400 (± 2) mm.

4.3.3. Compressed pellet of secondary explosive, recessed to receive detonator

Explosive: hexogen/wax 95/5 or tetryl or similar secondary explosive, with or without added graphite.

Density: 1 500 to 1 600 kg/m³

Diameter: 19 to 21 mm

Height: 19 to 23 mm

Central recess to receive detonator: diameter 7 to 7,3 mm, depth 12 mm.

4.3.4. Seamless steel tube as specified in ISO 65 — 1981 — Heavy Series, with nominal dimensions DN 100 (4")

Outside diameter: 113,1 to 115,0 mm

Wall thickness: 5,0 to 6,5 mm

Length: 1 005 (± 2) mm.

4.3.5. Bottom plate

Material: steel of good weldable quality

Dimensions: 160 × 160 mm

Thickness: 5 to 6 mm

4.3.6. Six lead cylinders

Diameter: 50 (± 1) mm

Height: 100 to 101 mm

Materials: soft lead, at least 99,5 % purity.

4.3.7. Steel block

Length: at least 1 000 mm

▼ B

Width: at least 150 mm

Height: at least 150 mm

Mass: at least 300 kg if there is no firm base for the steel block.

4.3.8. Plastic or cardboard cylinder for booster charge

Wall thickness: 1,5 to 2,5 mm

Diameter: 92 to 96 mm

Height: 64 to 67 mm

4.3.9. Detonator (electric or non-electric) with initiation force 8 to 10

4.3.10. Wooden disc

Diameter: 92 to 96 mm. Diameter to be matched to the internal diameter of the plastic or cardboard cylinder (4.3.8)

Thickness: 20 mm

4.3.11. Wooden rod of same dimensions as detonator (4.3.9)

4.3.12. Dressmaking pins (maximum length 20 mm)

4.4. *Procedure*

4.4.1. Preparation of booster charge for insertion into steel tube

There are two methods of initiation of the explosive in the booster charge, depending on the availability of equipment.

4.4.1.1. Seven-point simultaneous initiation

The booster charge prepared for use is shown in Figure 1.

4.4.1.1.1. Drill holes in the wooden disc (4.3.10) parallel to the axis of the disc through the centre and through six points symmetrically distributed around a concentric circle 55 mm in diameter. The diameter of the holes must be 6 to 7 mm (see Section A-B in Figure 1), depending on the diameter of the detonating cord used (4.3.2).

4.4.1.1.2. Cut seven lengths of flexible detonating cord (4.3.2) each 400 mm long, avoiding any loss of explosive at each end by making a clean cut and immediately sealing the end with adhesive. Push each of the seven lengths through the seven holes in the wooden disc (4.3.10) until their ends project a few centimetres on the other side of the disc. Then insert a small dressmaking pin (4.3.12) transversally into the textile sleeve of each length of cord 5 to 6 mm from the end and apply adhesive around the outside of the lengths of cord in a band 2 cm wide adjacent to the pin. Finally, pull the long piece of each cord to bring the pin into contact with the wooden disc.

4.4.1.1.3. Shape the plastic explosive (4.3.1) to form a cylinder 92 to 96 mm in diameter, depending on the diameter of the cylinder (4.3.8). Stand this cylinder upright on a level surface and insert the shaped explosive. Then insert the wooden disc⁽¹⁾ carrying the seven lengths of detonating cord into the top of the cylinder and press it down onto the explosive. Adjust the height of the cylinder (64 to 67 mm) so that its top edge does not extend beyond the level of the wood. Finally, fix the cylinder to the wooden disc for instance with staples or small nails, around its entire circumference.

⁽¹⁾ The diameter of the disc must always correspond to the inside diameter of the cylinder.

▼B

4.4.1.1.4. Group the free ends of the seven lengths of detonating cord around the circumference of the wooden rod (4.3.11) so that their ends are all level in a plane perpendicular to the rod. Secure them in a bundle around the rod by means of adhesive tape ⁽¹⁾.

4.4.1.2. Central initiation by a compressed pellet

The booster charge prepared for use is shown in Figure 2.

4.4.1.2.1. Preparing a compressed pellet

Taking the necessary safety precautions, place 10 grams of a secondary explosive (4.3.3) in a mould with an inside diameter of 19 to 21 mm and compress to the correct shape and density.

(The ratio of diameter: height should be roughly 1:1).

In the centre of the bottom of the mould there is a peg, 12 mm in height and 7,0 to 7,3 mm in diameter (depending on the diameter of the detonator used), which forms a cylindrical recess in the compressed cartridge for subsequent insertion of the detonator.

4.4.1.2.2. Preparing the booster charge

Place the explosive (4.3.1) into the cylinder (4.3.8) standing upright on a level surface, then press it down with a wooden die to give the explosive a cylindrical shape with a central recess. Insert the compressed pellet into this recess. Cover the cylindrically shaped explosive containing the compressed pellet with a wooden disc (4.3.10) having a central hole 7,0 to 7,3 mm in diameter for insertion of a detonator. Fix the wooden disc and the cylinder together with a cross of adhesive tape. Ensure that the hole drilled in the disc and the recess in the compressed pellet are coaxial by inserting the wooden rod (4.3.11).

4.4.2. Preparing steel tubes for the detonation tests

At one end of the steel tube (4.3.4), drill two diametrically opposed holes 4 mm in diameter perpendicularly through the side wall at a distance of 4 mm from the edge.

Butt weld the bottom plate (4.3.5) to the opposite end of the tube, completely filling the right angle between the bottom plate and the wall of the tube with weld metal around the entire circumference of the tube.

4.4.3. Filling and charging the steel tube

See Figures 1 and 2.

4.4.3.1. The test sample, the steel tube and the booster charge must be conditioned to temperatures of 20 (\pm 5) °C. 16 to 18 kg of the test sample are needed for two detonation tests.

4.4.3.2. Place the tube upright with its square bottom plate resting on a firm, flat surface, preferably concrete. Fill the tube to about one-third of its height with the test sample and drop it 10 cm vertically onto the floor five times to compact the prills or granules as densely as possible in the tube. To accelerate compaction, vibrate the tube by striking the side wall with a 750 to 1 000-gram hammer between drops for a total of 10 times.

⁽¹⁾ NB: When the six peripheral lengths of cord are taut after assembly, the central cord must remain slightly slack.

▼B

Repeat this charging method with another portion of the test sample. Finally, a further addition shall be made such that, after compaction by raising and dropping the tube 10 times and a total of 20 intermittent hammer blows, the charge fills the tube to a distance of 70 mm from its orifice.

The filling height of the sample must be adjusted in the steel tube so that the booster charge (4.4.1.1 or 4.4.1.2) to be inserted later will be in close contact with the sample over its entire surface.

4.4.3.3. Insert the booster charge into the tube so that it is in contact with the sample; the top surface of the wooden disc must be 6 mm below the end of the tube. Ensure essential close contact between explosive and test sample by adding or removing small quantities of sample. As shown in Figures 1 and 2, split pins should be inserted through the holes near the open end of the tube and their legs opened flat against the tube.

4.4.4. Positioning of the steel tube and lead cylinders (see figure 3)

4.4.4.1. Number the bases of the lead cylinders (4.3.6) 1 to 6. Make six marks 150 mm apart on the centre line of a steel block (4.3.7) lying on a horizontal base, with the first mark at least 75 mm from the edge of the block. Place a lead cylinder upright on each of these marks, with the base of each cylinder centred on its mark.

4.4.4.2. Lay the steel tube prepared according to 4.4.3 horizontally on the lead cylinders so that the axis of the tube is parallel to the centre line of the steel block and the welded end of the tube extends 50 mm beyond lead cylinder No 6. To prevent the tube from rolling, insert small wooden wedges between the tops of the lead cylinders and the tube wall (one on each side) or place a cross of wood between the tube and the steel block.

Note: Make sure that the tube is in contact with all six lead cylinders; a slight curvature of the tube surface can be compensated for by rotating the tube about its longitudinal axis; if any of the lead cylinders is too tall, tap the cylinder in question carefully with a hammer until it is the required height.

4.4.5. Preparation for detonation

4.4.5.1. Set up the apparatus according to the 4.4.4 in a bunker or suitably prepared underground site (e.g. mine or tunnel). Ensure that the temperature of the steel tube is kept at 20 (\pm 5) °C before detonation.

Note: Should such firing sites not be available, the work can, if necessary, be done in a concrete-lined pit covered over with wooden beams. Detonation can cause steel fragments to be projected with high kinetic energy, therefore, firing must be carried out at a suitable distance from dwellings or thoroughfares.

4.4.5.2. If the booster charge with seven-point initiation is used, ensure that the detonation cords are stretched out as described in the footnote to 4.4.1.1.4 and arranged as horizontally as possible.

4.4.5.3. Finally, remove the wooden rod and replace with the detonator. Do not carry out firing until the danger zone has been evacuated and the test personnel have taken cover.

▼B

- 4.4.5.4. Detonate the explosive.
- 4.4.6. Allow sufficient time for the fumes (gaseous and sometimes toxic decomposition products such as nitrous gases) to disperse, then collect the lead cylinders and measure their heights with a Vernier caliper
- Record for each of the marked lead cylinders, the degree of crushing expressed as a percentage of the original height of 100 mm. If the cylinders are crushed obliquely, record the highest and the lowest values and calculate the average.
- 4.4.7. A probe for continuous measurement of the detonation velocity can be used; the probe should be inserted longitudinally to the axis of the tube or along its side wall
- 4.4.8. Two detonation tests per sample are to be carried out
- 4.5. *Test report*
- Values for the following parameters are to be given in the test report for each of the detonation tests:
- the values actually measured for the outside diameter of the steel tube and for the wall thickness,
 - the Brinell hardness of the steel tube,
 - the temperature of the tube and the sample shortly before firing,
 - the packing density (kg/m^3) of the sample in the steel tube,
 - the height of each lead cylinder after firing, specifying the corresponding cylinder number,
 - method of initiation employed for the booster charge.
- 4.5.1. Evaluation of test results
- If, in each firing, the crushing of at least one lead cylinder is less than 5 %, the test shall be considered conclusive and the sample in conformity with the requirements of Annex III.2.

▼B

Figure 1

Booster charge with seven-point initiation

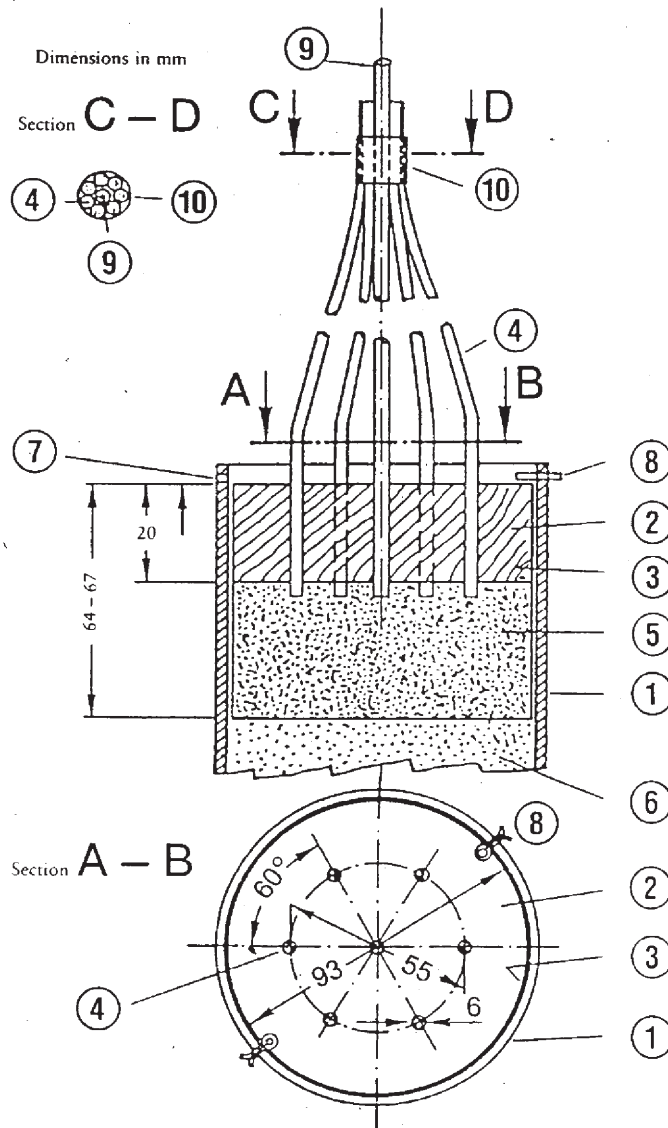

- | | |
|---------------------------------|---|
| ① Steel tube | ⑥ Test sample |
| ② Wooden disc with seven holes | ⑦ 4-mm-diameter hole drilled to receive split pin ⑧ |
| ③ Plastic or cardboard cylinder | ⑧ Split pin |
| ④ Detonating cords | ⑨ Wooden rod surrounded by ④ |
| ⑤ Plastic explosive | ⑩ Adhesive tape for securing ④ around ⑨ |

▼B

Figure 2

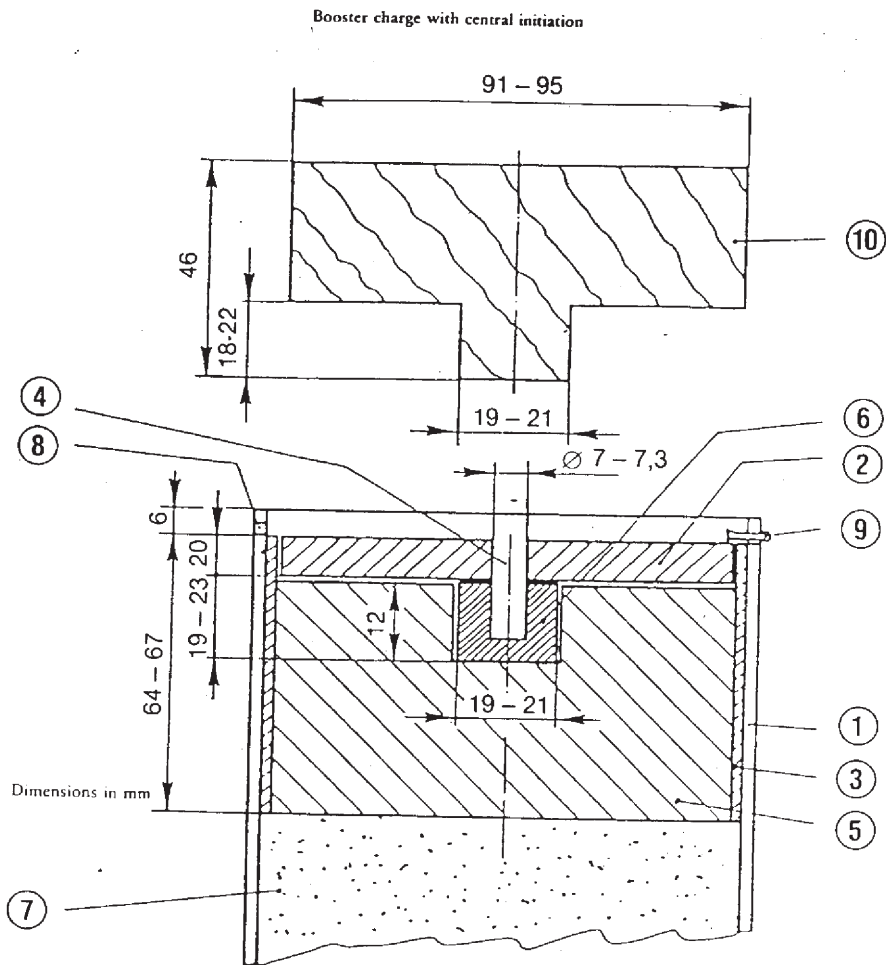

- | | |
|---------------------------------|---|
| ① Steel tube | ⑥ Compressed peller |
| ② Wooden disc | ⑦ Test sample |
| ③ Plastic or cardboard cylinder | ⑧ 4-mm-diameter hole drilled to receive split pin ⑨ |
| ④ Wooden rod | ⑨ Split pin |
| ⑤ Plastic explosive | ⑩ Wooden die for ⑤ |

▼B

Figure 3

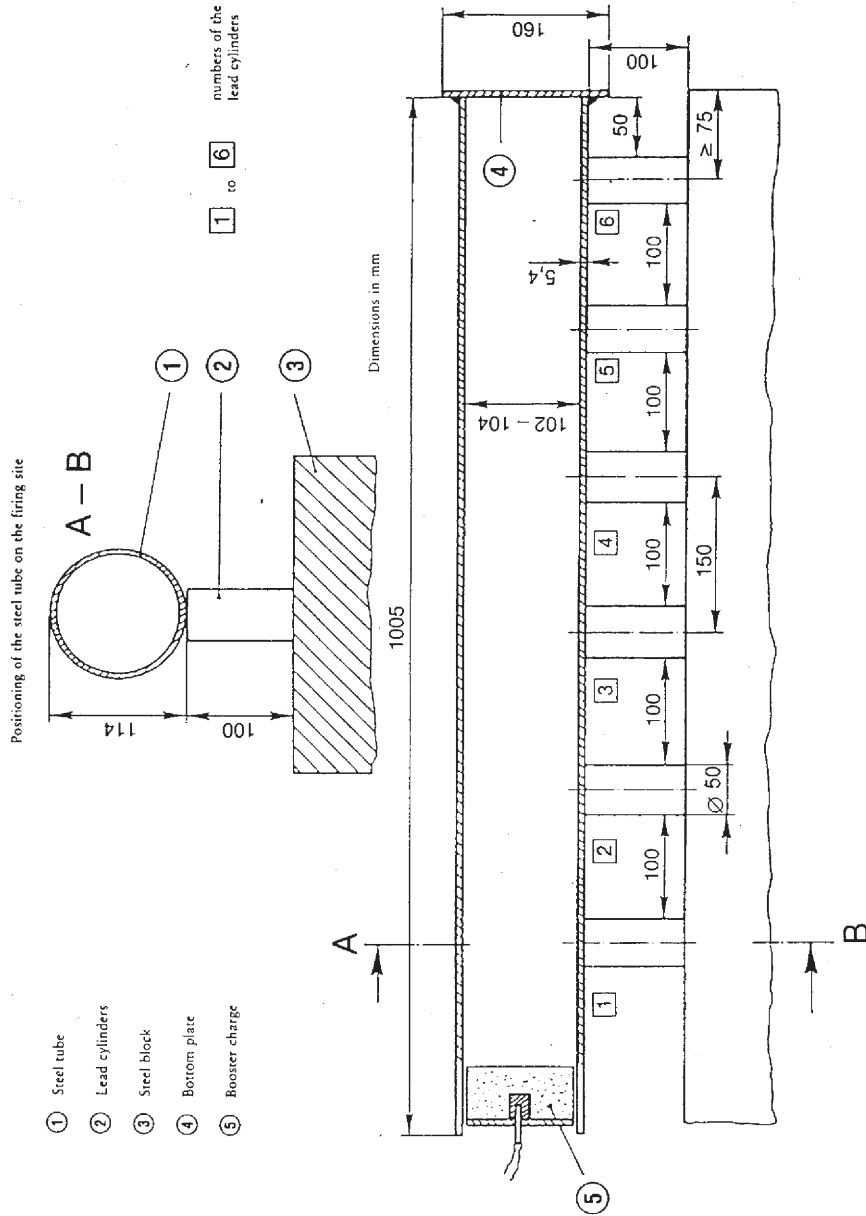

*ANNEX IV***METHODS OF SAMPLING AND ANALYSIS****A. METHOD OF SAMPLING FOR THE CONTROL OF FERTILISERS****INTRODUCTION**

Correct sampling is a difficult operation which requires the greatest of care. The need to obtain a sufficiently representative sample for the official testing of fertilisers cannot, therefore, be stressed too much.

The sampling method described below must be applied with strict accuracy by specialists with experience of the conventional sampling procedure.

1. Purpose and scope

Samples intended for the official control of fertilisers, for quality and composition, shall be taken according to the methods described below. Samples thus obtained shall be considered as representative of the sampled portions.

2. Sampling officers

The samples shall be taken by specialist officers authorised for that purpose by the Member States.

3. Definitions

Sampled portion: A quantity of product constituting a unit, and having characteristics presumed to be uniform.

Incremental sample: A quantity taken from one point in the sampled portion.

Aggregate sample: An aggregate of incremental samples taken from the same sampled portion.

Reduced sample: A representative part of the aggregate sample, obtained from the latter by a process of reduction.

Final sample: A representative part of the reduced sample.

4. Apparatus

4.1. The sampling apparatus must be made of materials which cannot affect the characteristics of the products to be sampled. Such apparatus may be officially approved by the Member States.

4.2. *Apparatus recommended for the sampling of solid fertilisers***4.2.1. Manual sampling**

4.2.1.1. Flat-bottomed shovel with vertical sides.

4.2.1.2. Sampling spear with a long split or compartments. The dimensions of the sampling spear must be appropriate to the characteristics of the sampled portion (depth of container, dimensions of sack, etc.) and to the particle size of the fertiliser.

4.2.2. Mechanical sampling

Approved mechanical apparatus may be used for the sampling of moving fertilisers.

4.2.3. Divider

Apparatus designed to divide the sample into equal parts may be used for taking incremental samples and for the preparation of reduced and final samples.

▼B

- 4.3. *Apparatus recommended for the sampling of fluid fertilisers*
- 4.3.1. Manual sampling
Open tube, probe, bottle or another appropriate equipment able to take samples at random from the sampled portion.
- 4.3.2. Mechanical sampling
Approved mechanical apparatus may be used for sampling of moving fluid fertilisers.
5. **Quantitative requirements**
- 5.1. *Sampled portion*
The size of the sampled portion must be such that each of its constituent parts can be sampled.
- 5.2. *Incremental samples*
- 5.2.1. Loose solid fertilisers or fluid fertilisers in containers exceeding 100 kg
- 5.2.1.1. Sampled portions not exceeding 2,5 tonnes:
Minimum number of incremental samples: seven
- 5.2.1.2. Sampled portions exceeding 2,5 tonnes and up to 80 tonnes:
Minimum number of incremental samples:
 $\sqrt{20}$ times the number of tonnes making up the sampled portion ⁽¹⁾
- 5.2.1.3. Sampled portions exceeding 80 tonnes:
Minimum number of incremental samples: 40
- 5.2.2. Packaged solid fertilisers or fluid fertilisers in containers (= packages each not exceeding 100 kg)
- 5.2.2.1. Packages of more than 1 kg
- 5.2.2.1.1. Sampled portions of less than five packages:
Minimum number of packages to be sampled ⁽²⁾: all packages.
- 5.2.2.1.2. Sampled portions of five to 16 packages:
Minimum number of packages to be sampled ⁽²⁾: four.
- 5.2.2.1.3. Sampled portions of 17 to 400 packages:
Minimum number of packages to be sampled ⁽²⁾:
 $\sqrt{\text{number of packages making up the sampled portion}}$ ⁽¹⁾
- 5.2.2.1.4. Sampled portions exceeding 400 packages:
Minimum number of packages to be sampled ⁽²⁾: 20.
- 5.2.2.2. Packages not exceeding 1 kg:
Minimum number of packages to be sampled ⁽²⁾: four.
- 5.3. *Aggregate sample*
A single aggregate sample per sampled portion is required. The total mass of the incremental samples making up the aggregate sample shall be not less than the following:
- 5.3.1. Loose solid fertilisers or fluid fertilisers in containers exceeding 100 kg: 4 kg.

⁽¹⁾ Where the number obtained is a fraction, it should be rounded up to the next whole number.

⁽²⁾ For packages whose contents do not exceed 1 kg, an incremental sample shall be the contents of one original package.

▼B

5.3.2. Packaged solid fertilisers or fluid fertilisers in containers (= packages) each not exceeding 100 kg

5.3.2.1. Packages of more than 1 kg: 4 kg

5.3.2.2. Packages not exceeding 1 kg: mass of the contents of four original packages.

5.3.3. Ammonium nitrate fertiliser sample for tests according to Annex III.2: 75 kg

5.4. *Final samples*

The aggregate sample gives the final samples on reduction when necessary. Analysis of at least one final sample is required. The mass of the sample for analysis shall not be less than 500 g.

5.4.1. Solid and fluid fertilisers

5.4.2. Ammonium nitrate fertiliser sample for tests

The aggregate sample gives the final sample for tests on reduction when necessary.

5.4.2.1. Minimum final sample mass for Annex III.1 tests: 1 kg

5.4.2.2. Minimum final sample mass for Annex III.2 tests: 25 kg

6. **Instructions for taking, preparing and packaging the samples**

6.1. *General*

The samples must be taken and prepared as quickly as possible bearing in mind the precautions necessary to ensure that they remain representative of the fertiliser sampled. Instruments and also surfaces and containers intended to receive samples must be clean and dry.

In the case of fluid fertilisers, if possible the sampled portion should be mixed prior to sampling.

6.2. *Incremental samples*

Incremental samples must be taken at random throughout the whole sampled portion and they must be of approximately equal sizes.

6.2.1. Loose solid fertilisers or fluid fertilisers in containers exceeding 100 kg

An imaginary division shall be made of the sampled portion into a number of approximately equal parts. A number of parts corresponding to the number of incremental samples required in accordance with 5.2 shall be selected at random and at least one sample taken from each of these parts. Where it is not possible to comply with the requirements of 5.1 when sampling bulk fertilisers or fluid fertilisers in containers exceeding 100 kg the sampling should be carried out when the sampled portion is being moved (loading or unloading). In this case samples shall be taken from the randomly selected notional parts as defined above while these are being moved.

6.2.2. Packaged solid fertilisers or fluid fertilisers in containers (= packages) each not exceeding 100 kg

Having selected the required number of packages for sampling as indicated in 5.2, part of the contents of each package shall be removed. Where necessary, the samples shall be taken after emptying the packages separately.

6.3. *Preparation of aggregate sample*

The incremental samples shall be mixed to form a single aggregate sample.

▼B**6.4. Preparation of the final sample**

The material in the aggregate sample shall be carefully mixed ⁽¹⁾.

If necessary the aggregate sample should first be reduced to at least 2 kg (reduced sample) either by using a mechanical divider or by the quartering method.

At least three final samples shall then be prepared, of approximately the same amount and conforming to the quantitative requirements of 5.4. Each sample shall be put into an appropriate air tight container. All necessary precautions shall be taken to avoid any change in the characteristics of the sample.

For the tests of Annex III, sections 1 and 2, the final samples shall be kept at a temperature between 0 °C and 25 °C.

7. Packaging of final samples

The containers or packages shall be sealed and labelled (the total label must be incorporated in the seal) in such a manner that they cannot be opened without damaging the seal.

8. Sampling record

A record must be kept of each sampling, permitting each sampled portion to be identified unambiguously.

9. Destination of samples

For each sample portion at least one final sample shall be sent as quickly as possible to an authorised analytical laboratory or to the test institution, together with the information necessary for the analysis or the test.

B. METHODS FOR THE ANALYSIS OF FERTILISERS

(See table of contents p. 2.)

General observations**Laboratory equipment**

In the descriptions of the methods, general laboratory equipment has not been precisely defined, except that the sizes of flasks and pipettes are given. In all cases laboratory apparatus must be well cleaned, particularly when small quantities of elements are to be determined.

Control tests

Before analysis it is necessary to ensure that all apparatus functions well and that the analytical technique is carried out correctly, using where appropriate chemical compounds of known composition (e.g. ammonium sulphate, mono potassium phosphate, etc.). Nevertheless, the results from analysed fertilisers can indicate wrong chemical composition if the analytical technique is not rigorously followed. On the other hand, a certain number of determinations are empirical and are relative to products of complex chemical composition. It is recommended that where available, laboratories should make use of standard reference fertilisers of well defined composition.

General provisions relating to methods of analysing fertilisers**1. Reagents**

Unless otherwise specified in the method of analysis, all of the reagents must be analysis-pur (a.p.). Where micro-nutrients are to be analysed the purity of the reagents must be checked by means of a blank test. Depending upon the result obtained, it might be necessary to conduct a further purification.

⁽¹⁾ Any lumps shall be broken up (if necessary by separating them out and returning them to the sample).

▼ B

2. Water

Where dissolution, dilution, rinsing or washing operations referred to in the methods of analysis do not specify the nature of solvents or diluents the use of water is implied. Normally, the water will have to be demineralised or distilled. In these specific instances, as mentioned in the method of analysis, that water will have to be subjected to specific purification processes.

3. Laboratory equipment

In view of the equipment normally used in inspection laboratories, the apparatus described in the methods of analysis is restricted to special instruments and apparatus or to such demanded by any specific requirements. This equipment must be perfectly clean, above all where small quantities are to be determined. The laboratory will have to ensure the accuracy of any graduated glassware used by referring to appropriate metrological standards.

▼ M7

Method 1

Preparation of the sample for analysis

EN 1482-2: Fertilisers and liming materials — Sampling and sample preparation — Part 2: Sample preparation

▼ B

Methods 2

Nitrogen**▼ M7**

Method 2.1

Determination of ammoniacal nitrogen

EN 15475: Fertilisers — Determination of ammoniacal nitrogen

This method of analysis has been ring-tested.

▼ B

Methods 2.2

Determination of nitric and ammoniacal nitrogen**▼ M7**

Method 2.2.1

Determination of nitric and ammoniacal nitrogen according to Ulsch

EN 15558: Fertilisers — Determination of nitric and ammoniacal nitrogen according to Ulsch

This method of analysis has not been ring-tested.

Method 2.2.2

Determination of nitric and ammoniacal nitrogen according to Arnd

EN 15559: Fertilisers — Determination of nitric and ammoniacal nitrogen according to Arnd

This method of analysis has not been ring-tested.

Method 2.2.3

Determination of nitric and ammoniacal nitrogen according to Devarda

EN 15476: Fertilisers — Determination of nitric and ammoniacal nitrogen according to Devarda

This method of analysis has been ring-tested.

▼ B

Method 2.3

Determination of total nitrogen**▼ M7**

Method 2.3.1

Determination of the total nitrogen in calcium cyanamide nitrate free

EN 15560: Fertilisers — Determination of total nitrogen in calcium cyanamide nitrate free

This method of analysis has not been ring-tested.

Method 2.3.2

Determination of total nitrogen in calcium cyanamide containing nitrates

EN 15561: Fertilisers — Determination of total nitrogen in calcium cyanamide containing nitrates

This method of analysis has not been ring-tested.

Method 2.3.3

Determination of total nitrogen in urea

EN 15478: Fertilisers — Determination of total nitrogen in urea

This method of analysis has been ring-tested.

Method 2.4

Determination of cyanamide nitrogen

EN 15562: Fertilisers — Determination of cyanamide nitrogen

This method of analysis has not been ring-tested.

Method 2.5

Spectrophotometric determination of biuret in urea

EN 15479: Fertilisers — Spectrophotometric determination of biuret in urea

This method of analysis has been ring-tested.

▼ B

Methods 2.6

Determination of different forms of nitrogen in the same sample**▼ M7**

Method 2.6.1

Determination of different forms of nitrogen in the same sample in fertilisers containing nitrogen as nitric, ammoniacal, urea and cyanamide nitrogen

EN 15604: Fertilisers — Determination of different forms of nitrogen in the same sample containing nitrogen, as nitric, ammoniacal, urea and cyanamide nitrogen

This method of analysis has not been ring-tested.

▼ M8

Method 2.6.2

Determination of total nitrogen in fertilisers containing nitrogen only as nitric, ammoniacal and urea nitrogen by two different methods

EN 15750: Fertilizers. Determination of total nitrogen in fertilizers containing nitrogen only as nitric, ammoniacal and urea nitrogen by two different methods.

This method of analysis has been ring-tested.

▼M8

Method 2.6.3

Determination of urea condensates using HPLC — Isobutylenediurea and crotonylidenediurea (method A) and methylen-urea oligomers (method B)

EN 15705: Fertilizers. Determination of urea condensates using high-performance liquid chromatography (HPLC). Isobutylenediurea and crotonylidenediurea (method A) and methylen-urea oligomers (method B)

This method of analysis has been ring-tested.

▼B

Methods 3

Phosphorus

Methods 3.1

Extractions**▼M9**

Method 3.1.1

Extraction of phosphorus soluble in mineral acids

EN 15956: Fertilizers – Extraction of phosphorus soluble in mineral acids

This method of analysis has been ring-tested.

Method 3.1.2

Extraction of phosphorus soluble in 2 % formic acid

EN 15919: Fertilizers – Extraction of phosphorus soluble in 2 % formic acid

This method of analysis has not been ring-tested.

Method 3.1.3

Extraction of phosphorus soluble in 2 % citric acid

EN 15920: Fertilizers – Extraction of phosphorus soluble in 2 % citric acid

This method of analysis has not been ring-tested.

Method 3.1.4

Extraction of phosphorus which is soluble in neutral ammonium citrate

EN 15957: Fertilizers – Extraction of phosphorus which is soluble in neutral ammonium citrate

This method of analysis has been ring-tested.

▼B

Methods 3.1.5

Extraction by alkaline ammonium citrate**▼M9**

Method 3.1.5.1

Extraction of soluble phosphorus according to Petermann at 65 °C

EN 15921: Fertilizers – Extraction of phosphorus according to Petermann at 65 °C

This method of analysis has not been ring-tested.

▼ M9

Method 3.1.5.2

Extraction of the soluble phosphorus according to Petermann at ambient temperature*EN 15922: Fertilizers – Extraction of phosphorus according to Petermann at ambient temperature*

This method of analysis has not been ring-tested.

Method 3.1.5.3

Extraction of phosphorus soluble in Joulie's alkaline ammonium citrate*EN 15923: Fertilizers – Extraction of phosphorus in Joulie's alkaline ammonium citrate*

This method of analysis has not been ring-tested.

Method 3.1.6

Extraction of water soluble phosphorus*EN 15958: Fertilizers – Extraction of water soluble phosphorus*

This method of analysis has been ring-tested.

Method 3.2

Determination of extracted phosphorus*EN 15959: Fertilizers – Determination of extracted phosphorus*

This method of analysis has been ring-tested.

▼ B

Method 4

Potassium**▼ M7**

Method 4.1

Determination of the water-soluble potassium content*EN 15477: Fertilisers — Determination of the water-soluble potassium content*

This method of analysis has been ring-tested.

▼ B

Method 5

▼ M8**Carbon dioxide**

Method 5.1

Determination of carbon dioxide — Part I: method for solid fertilisers*EN 14397-1: Fertilizers and liming materials. Determination of carbon dioxide. Part I: method for solid fertilisers*

This method of analysis has been ring-tested.

▼B

Method 6

Chlorine

Method 6.1

Determination of chlorides in the absence of organic material1. **Scope**

This document defines the procedure for the determination of chloride, in the absence of organic material.

2. **Field of application**

All fertilisers which are free from organic material.

3. **Principle**

The chlorides, dissolved in water, are precipitated in an acid medium by an excess of standard solution of silver nitrate. The excess is titrated with a solution of ammonium thiocyanate in the presence of ferric ammonium sulphate (Volhard's method).

4. **Reagents**

Distilled or demineralised water, free from chlorides.

4.1. Nitrobenzene or diethyl ether

4.2. Nitric acid: 10 mol/l

4.3. *Indicator solution*

Dissolve 40 g of ferric ammonium sulphate $\text{Fe}_2(\text{SO}_4)_3 \cdot (\text{NH}_4)_2\text{SO}_4 \cdot 24\text{H}_2\text{O}$, in water and make up to one litre.

4.4. *Silver nitrate standard solution: 0,1 mol/l*

Preparation

Since this salt is hygroscopic and cannot be dried without risk of decomposition, it is advisable to weigh out approximately 9 g, dissolve in water and make up the volume to one litre. Adjust to 0,1 mol/l strength by titration of AgNO_3 0,1 mol/l.

5. **Apparatus**

5.1. Rotary shaker (35 to 40 turns per minute)

5.2. Burettes

5.3. A 500-ml graduated flask

5.4. Conical (Erlenmeyer) flask of 250 ml

6. **Preparation of the sample**

See Method 1.

7. **Procedure**7.1. *Sample and preparation of the solution*

Place 5 g of the sample, weighed out to nearest 0,001 g, in a 500-ml graduated flask and add 450 ml of water. Mix for half an hour on the shaker (5.1); make up to 500 ml with distilled water; mix and filter into a beaker.

7.2. *Determination*

Take an aliquot part of the filtrate containing not more than 0,150 g of chloride. For example 25 ml (0,25 g), 50 ml (0,5 g) or 100 ml (1 g). If the sample taken is smaller than 50 ml it is necessary to make up the volume to 50 ml with distilled water.

Add 5 ml of nitric acid 10 mol/l (4.2), 20 ml of indicator solution (4.3), and two drops of ammonium thiocyanate standard solution (a sample of this latter reagent is taken with a burette adjusted to zero for this purpose).

▼ B

With a burette then add silver nitrate standard solution (4.4) until there is an excess of 2 to 5 ml. Add 5 ml of nitrobenzene or 5 ml of diethyl ether (4.1) and shake well to agglomerate the precipitate. Titrate the excess silver nitrate with ammonium thiocyanate 0,1 mol/l (4.5) until a red-brown colour appears which remains after the flask has been shaken slightly.

Note

Nitrobenzene or diethyl ether (but above all nitrobenzene) prevents the silver chloride from reacting with thiocyanate ions. Thus a clear colour change is obtained.

7.3. *Blank test*

Carry out a blank test (omitting the sample) under the same conditions and allow for it when calculating the final result.

7.4. *Control test*

Before carrying out the estimations check the accuracy of the Method by using an aliquot part of a freshly prepared solution of potassium chloride, such that this part contains a known quantity in the order of 100 mg of chloride.

8. **Expression of the result**

Express the result of the analysis as a percentage of chloride contained in the sample as it has been received for analysis.

Calculate the percentage of chloride (Cl) with the formula:

$$\% \text{ chloride} = 0,003546 \times \frac{(V_z - V_{cz}) - (V_a - V_{ca}) \times 100}{M}$$

where

V_z = number of millilitres of silver nitrate 0,1 mol/l,

V_{cz} = number of millilitres of silver nitrate 0,1 mol/l, used in the blank test,

V_a = number of millilitres of ammonium thiocyanate 0,1 mol/l,

V_{ca} = number of millilitres of ammonium thiocyanate 0,1 mol/l, used in the blank test,

M = mass, in grams, of the sample taken (7.2).

Methods 7**Fineness of grinding****▼ M9****Method 7.1****Determination of the fineness of grinding (dry procedure)**

EN 15928: Fertilizers – Determination of the fineness of grinding (dry procedure)

This method of analysis has not been ring-tested.

Method 7.2**Determination of the fineness of grinding of soft natural phosphates**

EN 15924: Fertilizers – Determination of the fineness of grinding of soft natural phosphates

This method of analysis has not been ring-tested.

▼ B

Methods 8

Secondary nutrients

▼ M9

Method 8.1

Extraction of total calcium, total magnesium, total sodium and total sulphur in the forms of sulphates

EN 15960: Fertilizers – Extraction of total calcium, total magnesium, total sodium and total sulphur in the forms of sulphates

This method of analysis has not been ring-tested.

Method 8.2

Extraction of total sulphur present in various forms

EN 15925: Fertilizers – Extraction of total sulphur present in various forms

This method of analysis has not been ring-tested.

Method 8.3

Extraction of water soluble calcium, magnesium, sodium and sulphur (in the form of sulphates)

EN 15961: Fertilizers – Extraction of water soluble calcium, magnesium, sodium and sulphur (in the form of sulphates)

This method of analysis has not been ring-tested.

Method 8.4

Extraction of water soluble sulphur where the sulphur is in various forms

EN 15926: Fertilizers – Extraction of water soluble sulphur where the sulphur is in various forms

This method of analysis has not been ring-tested.

Method 8.5

Extraction and determination of elemental sulphur

EN 16032: Fertilizers – Extraction and determination of elemental sulphur

This method of analysis has not been ring-tested.

▼ B

Method 8.6

Manganometric determination of extracted calcium following precipitation in the form of oxalate1. **Scope**

This document defines the procedure for determining the calcium in fertiliser extracts.

2. **Field of application**

This Method applies to EC fertilisers for which a declaration of the total and/or water-soluble calcium is provided for in Annex I.

▼ M43. **Principle**

Precipitation of the calcium contained in an aliquot of the extraction solution in the form of an oxalate, after separation and dissolution of the latter, by titration of oxalic acid using potassium permanganate.

▼B**4. Reagents**4.1. *Diluted hydrochloric acid*

One volume of hydrochloric acid ($d_{20} = 1,18$ g/ml) and one volume of water.

4.2. *1:10 dilute sulphuric acid*

One volume of sulphuric acid ($d_{20} = 1,84$ g/ml) in ten volumes of water.

4.3. *1:1 dilute ammonia solution*

One volume of ammonia ($d_{20} = 0,88$ g/ml) and one volume of water.

4.4. Saturated solution of ammonia oxalate $[(\text{NH}_4)_2\text{C}_2\text{O}_4 \cdot \text{H}_2\text{O}]$ at ambient temperature (approximately 40 grams per litre)

4.5. Citric acid solution, 30 % (m/v)

4.6. Ammonium chloride solution, 5 % (m/v)

4.7. Solution of bromothymol blue in ethanol, at 95 %, 0,1 % (m/v)

4.8. Solution of bromocresol green in ethanol, at 95 %, 0,04 % (m/v)

4.9. Standard solution of potassium permanganate, 0,02 mol/l

5. Apparatus5.1. Filter crucible with 5 to 20 μ porosity sintered glass

5.2. Hot water bath

6. Preparation of the aliquot to be analysed

Using a pipette, take an aliquot portion of the extraction solution obtained by Method 8.1 or 8.3, containing between 15 and 50 milligrams of Ca (= 21 to 70 milligrams of CaO). Let the volume of this aliquot be v_2 . Pour into a 400 millilitre beaker. If necessary, neutralise (turning of indicator (4.7) from green to blue) with a few drops of the ammonia solution (4.3).

Add one millilitre of the citric acid solution (4.5) and five millilitres of ammonium chloride solution (4.6).

7. Precipitation of the calcium oxalate

Add approximately 100 millilitres of water. Bring to the boil, add eight to ten drops of indicator solution (4.8) and, slowly, 50 millilitres of a hot ammonium oxalate solution (4.4). If a precipitate forms, dissolve by adding a few drops of hydrochloric acid (4.1). Neutralise very slowly with ammonia solution (4.3) while stirring continuously to a pH of 4,4 to 4,6 (turning of indicator (4.8) from green to blue). Place the beaker in a boiling hot water bath (5.2) for approximately 30 minutes.

Remove the beaker from the bath, leave standing for an hour and filter into the crucible (5.1).

8. Titration of the oxalate precipitate

Wash the beaker and crucible until the excess ammonium oxalate has been completely removed (this can be checked by the absence of chloride in the washing water). Place the crucible in the 400 millilitre beaker and dissolve the precipitate with 50 millilitres of hot sulphuric acid (4.2). Add water to the beaker in order to obtain a volume of approximately 100 millilitres. Bring to a temperature of 70 to 80 °C and titrate drop by drop with a permanganate solution (4.9) until the pink colour lasts for a minute. Let this volume be n .

▼B**9. Expression of results**

The calcium (Ca) content of the fertiliser is as follows:

$$\text{Ca (\%)} = n \times 0,2004 \times \frac{t}{0,02} \times \frac{v_1}{v_2 \times m}$$

Where

n = the number of millilitres of permanganate used,

m = the mass of the test sample in grams,

v₂ = the aliquot volume in millilitres,

v₁ = the volume of the extraction solution in millilitres,

t = the concentration of the permanganate solution in moles per litre.

$$\text{CaO (\%)} = \text{Ca (\%)} \times 1,400$$

Method 8.7**Determination of magnesium by atomic absorption spectrometry****1. Scope**

This document defines the procedure for determining the magnesium in fertiliser extracts.

2. Field of application

This Method applies to EC fertiliser extracts obtained by methods 8.1 and 8.3, for which a declaration of the total magnesium and/or water soluble magnesium is required, with the exception of the following fertilisers listed in Annex I D relating to secondary nutrients:

- type 4 (kieserite),
- type 5 (magnesium sulphate) and type 5.1 (magnesium sulphate solution),
- and with the exception of the following fertiliser listed in Annex I A 3 relating to potassic fertilisers:
 - type 7 (kieserite with potassium sulphate)
 - to which Method 8.8 applies.

The Method set out below applies to all fertiliser extracts containing elements in quantities that might interfere with the complexometric determination of magnesium.

3. Principle

Determination of magnesium by atomic absorption spectrometry after appropriate dilution of the extract.

4. Reagents

- 4.1. Hydrochloric acid, 1 mol/l solution
- 4.2. Hydrochloric acid, 0,5 mol/l solution
- 4.3. *Standard solution of magnesium, 1,00 milligrams per millilitre*
 - 4.3.1. Dissolve 1,013 grams of magnesium sulphate (MgSO₄, 7H₂O) in the 0,5 mol/l hydrochloric acid solution (4.2)
 - 4.3.2. Weigh out 1,658 grams of magnesium oxide (MgO), previously calcined to remove all traces of carbonation. Place in a beaker with 100 millilitres of water and 120 millilitres of 1 mol/l hydrochloric acid (4.1). When it has dissolved, decant quantitatively into a 1 000 millilitre graduated flask. Make up the volume by adding and mix

or

▼ B

4.3.3. Commercial standard solution

The laboratory is responsible for testing such solutions.

4.4. *Strontium chloride solution*

Dissolve 75 grams of strontium chloride ($\text{SrCl}_2 \cdot 6\text{H}_2\text{O}$) in a hydrochloric acid solution (4.2) and make up to 500 millilitres with the same acid solution.

5. **Apparatus**

Spectrometer fitted for atomic absorption, with a magnesium lamp, set at 285,2 nm.

Air-acetylene flame.

6. **Preparation of the sample**

See Methods 8.1 and 8.3.

7. **Procedure**

7.1. If the fertiliser has a declared magnesium (Mg) content of more than 6 % (i.e. 10 % as MgO), take 25 millilitres (V_1) of the extraction solution (6). Transfer into a 100 millilitre graduated flask, and make up to volume with water and mix. The dilution factor is $D_1 = 100/V_1$

7.2. Using a pipette, take 10 millilitres of the extraction solution (6) or the solution (7.1). Transfer into a 200 millilitre graduated flask. Make up to volume with the 0,5 mol/l hydrochloric acid solution (4.2) and mix. The dilution factor is 200/10

7.3. Dilute this solution (7.2) with the 0,5 mol/l hydrochloric acid solution (4.2) so as to obtain a concentration in the optimum working field of the spectrometer (5.1). V_2 is the volume of the sample in 100 millilitres. The dilution factor is $D_2 = 100/V_2$

The final solution should contain 10 % v/v of the strontium chloride solution (4.4).

7.4. *Preparation of blank solution*

Prepare a blank solution by repeating the whole procedure from the extraction (Method 8.1 or 8.3), omitting only the test sample of fertiliser.

7.5. *Preparation of calibration solutions*

By diluting the standard solution (4.3) with the 0,5 mol/l hydrochloric acid, prepared at least five calibration solutions of increasing concentration within the optimum measuring range of the apparatus (5.1).

These solutions should contain 10 % v/v of the strontium chloride solution (4.4).

7.6. *Measurement*

Set up the spectrometer (5.1) at a wavelength of 285,2 nm.

Spray, successively, the calibration solutions (7.5), the sample solution (7.3) and the blank solution (7.4), washing the instrument through with the solution to be measured next. Repeat this operation three times. Plot the calibration curve using the mean absorbancies of each of the calibrations (7.5) as the ordinates and the corresponding concentration of magnesium in $\mu\text{g/ml}$ as the abscissae. Determine the concentration of magnesium in the sample (7.3), X_s and blank (7.4), X_b , by reference to the calibration curve.

8. **Expression of results**

Calculate the amount of magnesium (Mg) or magnesium oxide (MgO) in the sample by reference to the calibration solutions and taking into consideration the blank.

▼ B

The percentage of magnesium (Mg) in the fertiliser is equal to:

$$\text{Mg (\%)} = \frac{(X_s - X_b) D_1 (200/10) D_2 500, 100}{1000.1000 M}$$

Where

X_s = the concentration of the solution to be analysed recorded on the calibration curve, in $\mu\text{g/ml}$.

X_b = the concentration of the blank solution as recorded on the calibration curve, in $\mu\text{g/ml}$.

D_1 = the dilution factor when the solution is diluted (7.1).

— It is equal to four if 25 millilitres are taken.

— It is equal to one when the solution is not diluted.

— D_2 = the dilution factor is 7.3.

— M = the mass of the test sample at the time of extraction.

— $\text{MgO (\%)} = \text{Mg (\%)} / 0,6$

Method 8.8

Determination of magnesium by complexometry

1. Scope

This document defines the procedure for the determination of magnesium in fertiliser extracts.

2. Field of application

This Method applies to the following EC fertiliser extracts for which the determination of total magnesium and/or water-soluble magnesium is provided for:

— fertilisers listed in Annex I: straight nitrogenous fertilisers, type 1b + 1c (calcium magnesium nitrate), type 7 (magnesium sulphonitrate), type 8 (nitrogenous fertilisers with magnesium) and straight potassic fertilisers, type 2 (enriched kainite), type 4 (potassium chloride containing magnesium), type 6 (potassium sulphate containing magnesium salt),

— fertilisers listed in the Annex I D relating to secondary nutrients.

3. Principle

The magnesium is solubilised by methods 8.1 and/or 8.3. First titration: with EDTA of Ca and Mg in the presence of Eriochrome black-T. Second titration: with EDTA of Ca in the presence of calcein or of calcon carbonic acid. Determination of magnesium by difference.

4. Reagents

4.1. Standard 0,05 mol/l solution of magnesium:

4.1.1. Dissolve 1,232 grams of magnesium sulphate ($\text{MgSO}_4 \cdot 7\text{H}_2\text{O}$) in the 0,5 mol/l hydrochloric acid solution (4.11) and make up to 100 millilitres with the same acid

or

4.1.2. Weigh out 2,016 grams of magnesium oxide, previously calcined to remove all traces of carbonation. Place it in a beaker with 100 millilitres of water

Stir in approximately 120 millilitres of approximately 1 mol/l hydrochloric acid (4.12).

▼B

After dissolution, transfer quantitatively into a graduated 1 000 millilitre flask. Make up to volume and mix.

One millilitre of these solutions should contain 1,216 milligrams of Mg (= 2,016 milligrams of MgO).

The laboratory is responsible for testing the strength of this standard solution.

4.2. *0,05 molar solution of EDTA*

Weigh out 18,61 grams of the dihydrated disodium salt of ethylenediaminetetraacetic ($C_{10}H_{14}N_2Na_2O_8 \cdot 2H_2O$), place it in a 1 000 millilitre beaker and dissolve in 600 to 800 millilitres of water. Transfer the solution quantitatively into a graduated 1 000 millilitre flask. Make up the volume and mix. Check this solution with the standard solution (4.1) by taking a sample of 20 millilitres of the latter and by titration according to the analytical procedure described at (7.2).

One millilitre of the EDTA solution should correspond to 1,216 milligrams of Mg (= 2,016 milligrams of MgO) and to 2,004 milligrams of Ca (= 2,804 milligrams CaO) (see remarks 10,1 and 10,6).

4.3. *0,05 molar standard solution of calcium*

Weigh out 5,004 grams of dry calcium carbonate. Place it in a beaker with 100 millilitres of water. Progressively stir in 120 millilitres of approximately 1 mol/l hydrochloric acid (4.12).

Bring to the boil in order to drive off the carbon dioxide, cool, transfer quantitatively into a graduated one-litre flask, make up the volume with water and mix. Check this solution against the EDTA solution (4.2) following analytical procedure (7.3). One millilitre of this solution should contain 2,004 milligrams of Ca (= 2,804 milligrams of CaO) and should correspond to one millilitre of the 0,05 molar EDTA solution (4.2).

4.4. *Calcein indicator*

Carefully mix in a mortar one gram of calcein with 100 grams of sodium chloride. Use 10 milligrams of this mixture. The indicator changes from green to orange. Titration must be carried out until an orange is obtained which is free from green tinges.

4.5. *Calcon carbonic acid indicator*

Dissolve 400 milligrams of calcon carbonic acid in 100 millilitres of methanol. This solution may only be kept for approximately four weeks. Use three drops of this solution. The indicator changes from red to blue. Titration must be carried out until a blue is obtained which is free from red tinges.

4.6. *Eriochrome black-T indicator*

Dissolve 300 milligrams of Eriochrome black-T in a mixture of 25 millilitres of propanol-1 and 15 millilitres of triethanolamine. This solution may only be kept for approximately four weeks. Use three drops of this solution. This indicator turns from red to blue and titration must be carried out until a blue is obtained which is free from red tinges. It changes colour only when magnesium is present. If necessary add one millilitre of the standard solution (4.1).

When both calcium and magnesium are present the EDTA first forms a complex with the calcium and then with the magnesium. In that case two elements are determined concurrently.

4.7. *Potassium cyanide solution*

Aqueous solution of KCN at 2 %. (Do not pipette by mouth and see 10.7).

4.8. *Solution of potassium hydroxide and potassium cyanide*

Dissolve 280 grams of KOH and 66 grams of KCN in water, make up the volume to one litre and mix.

▼ B4.9. *pH 10,5 buffer solution*

In a 500 millilitre graduated flask, dissolve 33 grams of ammonium chloride in 200 millilitres of water, add 250 millilitres of ammonia ($d_{20} = 0,91 \text{ g/ml}$) make up the volume with water and mix. Test the pH of the solution regularly.

4.10. Diluted hydrochloric acid: one volume of hydrochloric acid ($d_{20} = 1,18 \text{ g/ml}$) plus one volume of water

4.11. Hydrochloric acid solution approximately 0,5 mol/l

4.12. Hydrochloric acid solution approximately 1 mol/l

4.13. Sodium hydroxide solution 5 mol/l

5. **Apparatus**

5.1. Magnetic or mechanical stirrer

5.2. pH meter

6. **Control test**

Carry out a determination on aliquot parts of solutions (4.1 and 4.3) such that the Ca/Mg ratio is approximately equal to that of the solution to be analysed. To this end take (a) millilitres of Mg standard solution (4.3) and (b-a) millilitres of standard solution (4.1) (a) and (b) are the numbers of millilitre EDTA solution used in the two titrations performed on the solution to be analysed. This procedure is correct only if the solutions of EDTA, calcium and magnesium are exactly equivalent. If this is not the case, it is necessary to make corrections.

7. **Preparation of the solution to be analysed**

See methods 8.1 and 8.3.

8. **Determination**8.1. *Aliquot samples to be taken*

The aliquot part will as far as possible contain between 9 and 18 milligrams of magnesium (= 15 to 30 milligrams of MgO).

8.2. *Titration in the presence of Eriochrome black-T*

Pipette an aliquot part (8.1) of the solution to be analysed into a 400 millilitre beaker. Neutralise the surplus acid with the 5 mol/l sodium hydroxide solution (4.12) using the pH meter. Dilute with water to approximately 100 millilitres. Add 5 millilitres of the buffer solution (4.9). The pH measured by the meter must be $10,5 \pm 0,1$. Add 2 millilitres of the potassium cyanide solution (4.7) and three drops of the Eriochrome black-T indicator (4.6). Titrate with the EDTA solution (4.2). Stirring gently with the stirrer (5.1) (see 10,2, 10,3 and 10,4). Let 'b' be the number of millilitres of 0,05 mol/l EDTA solution.

8.3. *Titration in the presence of calcein or of calcon carbonic acid*

Pipette an aliquot part of the solution to be analysed equal to that taken from the above titration and place it in a 400 millilitre beaker. Neutralise the surplus acid with the 5 mol/l sodium hydroxide solution (4.13) using the pH meter. Dilute with water to about 100 millilitres. Add 10 millilitres of the KOH/KCN solution (4.8) and the indicator (4.4 or 4.5). Stirring gently with the stirrer (5.1) titrate with the EDTA solution (4.2) (see 10,2, 10,3 and 10,4). Let 'a' be the number of millilitres of 0,05 mol/l EDTA solution.

▼B**9. Expression of the results**

For the EC fertilisers to which the Method is applicable (5 grams of fertiliser in 500 millilitres of extract), the percentage content of the fertiliser is:

$$\text{MgO (\% in the fertiliser)} = \frac{(b - a) \times T}{M}$$

$$\text{Mg (\% in the fertiliser)} = \frac{(b - a) \times T'}{M}$$

Where

a = the number of millilitres of 0,05 mol/l EDTA solution used for the titration in the presence of calcein or calcon carbonic acid,

b = the number of millilitres of 0,05 mol/l EDTA solution used for the titration in the presence of Eriochrome black-T,

M = the mass of the sample present in the aliquot part taken (in grams),

T = 0,2016 × mol/l of the EDTA solution/0,05 (see 4.2),

T' = 0,1216 × mol/l of the EDTA solution/0,05 (see 4.2).

10. Remarks

- 10.1. The stoichiometric EDTA-metal ratio in the complexometric analyses is always 1:1 whatever the valency of the metal and in spite of the fact that EDTA is quadrivalent. The EDTA titration solution and the standard solutions will therefore be molar and not normal
- 10.2. Complexometric indicators are often sensitive to air. The solution may lose colour during titration. In this case, one or two drops of indicator must be added. This is true particularly in the case of eriochrome black and calcon carbonic acid
- 10.3. The metal-indicator complexes are often relatively stable and it may take some time for the colour to change. The last drops of EDTA must therefore be added slowly and a drop of 0,05 mol/l solution of magnesium (4.1) or calcium (4.3) added to ensure that the colour change has not already taken place. This is particularly true in the case of the eriochrome-magnesium complex
- 10.4. The turning of the indicator must be observed not vertically, but horizontally across the solution and the beaker must be placed against a white background in a well-lit position. The turning of the indicator may also be observed easily by placing the beaker on frosted glass lit moderately from below (25 watt lamp)
- 10.5. This analysis requires a certain amount of experience. The task will involve, *inter alia*, observing the colour changes of standard solutions 4.1 and 4.3. It is recommended that the determinations be carried out by the same laboratory chemist
- 10.6. If an EDTA solution of guaranteed strength is used (Titrisol, Normex, for example) this may simplify the control of the equivalence of standard solutions 4.1, 4.2 and 4.3
- 10.7. The solutions containing potassium cyanide must not be poured down the sink until the cyanide has been converted into a harmless compound, for example, by oxidization with sodium hypochlorite following alkalisation

▼M8

Method 8.9

Determination of the sulfates content using three different methods

EN 15749: Fertilizers. Determination of sulfates content using three different methods

This method of analysis has been ring-tested.

▼B

Method 8.10

Determination of the sodium extracted**1. Scope**

This document defines the procedure for determining the sodium in fertiliser extracts.

2. Field of application

This Method applies to EC fertilisers for which a declaration of the sodium is provided for in Annex I.

3. Principle

Following suitable dilution of the extract obtained via Method 8.1 and/or 8.3, the sodium content of the solution is determined by flame-emission spectrometry.

4. Reagents4.1. *Diluted hydrochloric acid*

One volume of hydrochloric acid for analysis ($d_{20} = 1,18$ g/ml) plus one volume of water.

4.2. Aluminium nitrate $\text{Al}(\text{NO}_3)_3 \cdot 9\text{H}_2\text{O}$

4.3. Caesium chloride, CsCl

4.4. Anhydrous sodium chloride, NaCl

4.5. *Caesium chloride and aluminium nitrate solution*

Dissolve in water 50 grams of caesium chloride (4.3) and 250 grams of aluminium nitrate (4.2) in a 1 000 millilitre graduated flask. Make up to volume with water and mix.

4.6. *Standard sodium solution of one milligram/millilitre of Na*

Dissolve in water 2,542 grams of sodium chloride (4.4) in a 1 000 millilitre graduated flask. Add 10 millilitres of hydrochloric acid (4.1). Make up to volume with water and mix.

5. Apparatus

Spectrometer equipped for flame emission, set at 589,3 nm.

6. Calibration solutions

6.1. Place 10 millilitres of standard solution (4.6) in a 250 millilitre graduated flask. Make up to volume and mix. Concentration of solution: 40 $\mu\text{g/ml}$ of Na

6.2. Place 0, 5, 10, 15, 20, 25 millilitres of the intermediate solution (6.1) in 100 millilitre graduated flasks. Add 10 millilitres of the solution (4.5). Make up to volume and mix. Concentration of solutions: 0, 2, 4, 6, 8, 10 $\mu\text{g/ml}$ of Na

▼ B**7. Preparation of solutions to be measured**

Depending upon the expected sodium content of the extraction solution as in Method 8.1 or 8.3 (five grams of fertiliser in 500 millilitres), carry out the dilutions in accordance with the following table:

Na ₂ O (%)	Na (%)	Intermediate dilution		Final dilution		Degree of dilution
		Sample (ml) (v ₂)	Dilution to ml (v ₃)	Sample (ml) (v ₄)	Dilution to ml	
3-5	2,2-3,7	10	50	10	100	50
5-10	3,7-7,4	10	100	10	100	100
10-20	7,4-15	10	100	5	100	200
20-38	15-28	5	100	5	100	400

Make up the intermediate dilution with water. For the final dilution add ten millilitres of the solution (4.5) to the 100 millilitre graduated flask.

For a test sample of one gram multiply the volume of the final dilution (v₄) by five.

8. Determination

Prepare the spectrometer (5.1) for the measurements at 589,3 nm. Calibrate the instrument by measuring the response of the calibration solutions (6.2). Then adjust the sensitivity of the instrument to use its entire scale when the most concentrated calibration solution is used. Then measure the response of the sample solution to be analysed (7). Repeat this operation three times.

9. Calculation of results

Draw a calibration curve by plotting the average response for each calibration solution along the ordinate and the corresponding concentrations, expressed in µg per millilitre on the abscissa. Determine from this the sodium concentration of the test solution. Calculate the quantity of sodium from the standard solutions taking account of the levels of dilution. Express the results as a percentage of the sample.

The percentage sodium (Na) content of the fertiliser is as follows:

$$\text{Na \%} = x \cdot \frac{v_3 v_1 10^{-2}}{v_4 v_2 m}$$

$$\text{Na}_2\text{O (\%)} = \text{Na(\%)} \times 1,348$$

Where

x = the concentration of the solution introduced into the spectrometer in µg/ml,

v₁ = the volume of the extraction solution in millilitres,

v₂ = the aliquot volume in the intermediate dilution in millilitres,

v₃ = the volume of intermediate dilution in millilitres,

v₄ = the aliquot volume in ml of the final dilution (to 100 millilitres),

m = the mass of the test sample in grams.

▼M9

Method 8.11

Determination of calcium and formate in calcium formate

EN 15909: Fertilizers – Determination of calcium and formate in calcium foliar fertilizers

This method of analysis has been ring-tested.

▼B

Methods 9

Micro-nutrients at a concentration of less than or equal to 10 %

Method 9.1

Extraction of total micro-nutrients1. **Scope**

This Method defines the procedure for extracting the following micro-nutrients: total boron, total cobalt, total copper, total iron, total manganese, total molybdenum and total zinc. The aim is to carry out the minimum number of extractions, making use wherever possible of the same extract to determine the total level of each of the micro-nutrients listed above.

2. **Field of application**

This procedure concerns EC fertilisers covered by Annex I E containing one or more of the following micro-nutrients: boron, cobalt, copper, iron, manganese, molybdenum and zinc. It is applicable to each micro-nutrient the declared content of which is less than or equal to 10 %.

3. **Principle**

Dissolution in boiling dilute hydrochloric acid.

Note

The extraction is empirical and may not be quantitative depending on the product or the other constituents of the fertiliser. In particular, in the case of certain manganese oxides, the quantity extracted may be substantially smaller than the total quantity of manganese which the product contains. It is the responsibility of the fertiliser manufacturers to ensure that the declared content actually corresponds to the quantity extracted under the conditions pertaining to the method.

4. **Reagents**4.1. *Dilute hydrochloric acid (HCl) solution, about 6 mol/l*

Mix 1 volume of hydrochloric acid ($d_{20} = 1,18$ g/ml) with 1 volume of water.

4.2. Concentrated ammonia solution (NH_4OH , $d_{20} = 0,9$ g/ml)5. **Apparatus**

Electric hotplate with variable temperature control.

Note

Where the boron content of an extract is to be determined, do not use borosilicate glassware. As the Method involves boiling, teflon or silica is preferable. Rinse the glassware thoroughly if it has been washed in detergents containing borates.

6. **Preparation of the sample**

See Method 1.

▼B**7. Procedure****7.1. Test sample**

Take a quantity of fertiliser weighing between 2 and 10 g depending on the declared content of element in the product. The following table shall be used to obtain a final solution which, after appropriate dilution, will be within the measuring range for each method. Samples should be weighed to within 1 mg.

Declared content of micro-nutrient in the fertiliser (%)	< 0,01	0,01-< 5	≥ 5-10
Mass of test sample (g)	10	5	2
Mass of element in the sample (mg)	1	0,5-250	100-200
Volume of extract V (ml)	250	500	500
Concentration of element in extract (mg/l)	4	1-500	200-400

Place the sample in a 250 ml beaker.

7.2. Preparation of the solution

If necessary moisten the sample with a little water, add 10 ml of dilute hydrochloric acid (4.1) per gram of fertiliser carefully, in small amounts, then add about 50 ml of water. Cover the beaker with a watch glass and mix. Bring to the boil on the hotplate and boil for 30 minutes. Allow to cool, stirring occasionally. Transfer quantitatively to a 250 or 500 ml volumetric flask (see Table). Make up to volume with water and mix thoroughly. Filter through a dry filter into a dry container. Discard the first portion. The extract must be perfectly clear.

It is recommended that the determination be carried out without delay on aliquot portions of the clear filtrate, if not the containers should be stoppered.

Remark

Extracts in which the boron content has to be determined: Adjust the pH to between 4 and 6 with concentrated ammonia (4.2).

8. Determination

The determination of each micro-nutrient is to be carried out on the aliquot portions indicated in the Method for each individual micro-nutrient.

If necessary, remove organic chelating or complexing substances from an aliquot portion of the extract by using Method 9.3. In the case of determination by atomic absorption spectrometry, such removal may not be necessary.

Method 9.2**Extraction of water-soluble micro-nutrients****1. Scope**

This Method defines the procedure for extracting water-soluble forms of the following micro-nutrients: boron, cobalt, copper, iron, manganese, molybdenum and zinc. The aim is to carry out the minimum number of extractions, making use wherever possible of the same extract to determine the level of each of the micro-nutrients listed above.

▼B**2. Field of application**

This procedure concerns EC fertilisers covered by Annex I containing one or more of the following micro-nutrients: boron, cobalt, copper, iron, manganese, molybdenum and zinc. It is applicable to each micro-nutrient the declared content of which is less than or equal to 10 %.

3. Principle

The micro-nutrients are extracted by shaking the fertiliser in water at 20 °C (± 2) °C.

Note

The extraction is empirical and may or may not be quantitative.

4. Reagents**4.1. Dilute hydrochloric acid (HCl) solution, about 6 mol/l**

Mix 1 volume of hydrochloric acid ($d_{20} = 1,18$ g/ml) with 1 volume of water.

5. Apparatus**5.1. Rotary shaker set at about 35 to 40 rpm****5.2. pH-meter****Note**

Where the boron content of the extract is to be determined, do not use borosilicate glassware. Teflon or silica is preferable for this extraction. Rinse the glassware thoroughly if it has been washed in detergents containing borates.

6. Preparation of the sample

See Method 1.

7. Procedure**7.1. Test sample**

Take a quantity of fertiliser weighing between 2 and 10 g depending on the declared content of the element in the product. The following table shall be used to obtain a final solution which, after appropriate dilution, will be within the measuring range for each method. The samples should be weighed to within 1 mg.

Declared content of micro-nutrient in the fertiliser (%)	< 0,01	0,01-< 5	$\geq 5-10$
Mass of test sample (g)	10	5	2
Mass of element in the sample (mg)	1	0,5-250	100-200
Volume of extract V (ml)	250	500	500
Concentration of element in extract (mg/l)	4	1-500	200-400

Place the sample in a 250 or 500 ml flask (according to the Table).

▼B7.2. *Preparation of the solution*

Add about 200 ml of water to the 250 ml flask or 400 ml of water to the 500 ml flask.

Stopper the flask well. Shake vigorously by hand to disperse the sample, then place the flask on the shaker and shake for 30 minutes.

Make up to volume with water and mix thoroughly.

7.3. *Preparation of the test solution*

Filter immediately into a clean, dry flask. Stopper the flask. Carry out the determination immediately after filtering.

Note

If the filtrate gradually becomes cloudy, make another extraction following 7.1 and 7.2 in a flask of volume V_e . Filter into a calibrated flask of volume W which has previously been dried and has received 5,00 ml of dilute hydrochloric acid (4.1). Stop the filtration at the exact moment when the calibration mark is reached. Mix thoroughly.

Under these conditions the value of V in the expression of results is:

$$V = V_e \times W / (W - 5)$$

The dilutions in the expression of results depend on this value of V .

8. **Determination**

The determination of each micro-nutrient is carried out on the aliquot portions indicated in the Method for each individual micro-nutrient.

If necessary, remove organic chelating or complexing substances from an aliquot portion by using Method 9.3. In the case of determination by atomic absorption spectrometry, such removal may not be necessary.

Method 9.3

Removal of organic compounds from fertiliser extracts1. **Scope**

This Method defines a procedure for removing organic compounds from fertiliser extracts.

2. **Field of application**

This procedure is applicable to analysing samples of fertilisers extracted by Methods 9.1 and 9.2 for which a declaration of total and/or water-soluble element is required by Annex I E to this Regulation.

Note

The presence of small quantities of organic matter usually does not affect determination by means of atomic absorption spectrometry.

3. **Principle**

The organic compounds in an aliquot portion of the extract are oxidised with hydrogen peroxide.

▼ B**4. Reagents****4.1. Dilute hydrochloric acid (HCl) solution, about 0,5 mol/l**

Mix 1 volume of hydrochloric acid ($d_{20} = 1,18$ g/ml) with 20 volumes of water.

4.2. Hydrogen peroxide solution (30 % H₂O₂, $d_{20} = 1,11$ g/ml), free from micro-nutrients**5. Apparatus**

Electric hotplate with variable temperature control.

6. Procedure

Take 25 ml of the extract solution obtained by Method 9.1 or Method 9.2 and place in a 100 ml beaker. In the case of Method 9.2, add 5 ml of the dilute hydrochloric acid solution (4.1). Then add 5 ml of the hydrogen peroxide solution (4.2). Cover with a watch glass. Allow oxidation to occur at room temperature for about one hour, then bring gradually to boiling and boil for half an hour. If necessary, add a further 5 ml of the hydrogen peroxide to the solution once it has cooled. Then boil to remove the excess hydrogen peroxide. Allow to cool and transfer quantitatively to a 50 ml volumetric flask and make up to volume. Filter where necessary.

Account should be taken of this dilution when taking aliquot portions and calculating the percentage of micro-nutrient in the product.

Method 9.4**Determination of micro-nutrients in fertiliser extracts by atomic absorption spectrometry****(general procedure)****1. Scope**

This document defines a general procedure for determining the levels of certain micro-nutrients in fertiliser extracts by atomic absorption spectrometry.

2. Field of application

This procedure is applicable to analysing samples of fertilisers extracted by Methods 9.1 and 9.2 for which a declaration of total and/or water-soluble element is required by Annex I E to this Regulation.

Adaptations of this procedure for the various micro-nutrients are detailed in the methods defined specifically for each element.

Note

In most cases the presence of small quantities of organic matter will not affect determinations by atomic absorption spectrometry.

3. Principle

After the extract has been treated where necessary to reduce or eliminate interfering chemical species, the extract is diluted so that its concentration is in the optimum range of the spectrometer at a wave-length suitable for the micro-nutrient to be determined.

▼ B**4. Reagents**4.1. *Dilute hydrochloric acid solution (HCl), about 6 mol/l:*

Mix one volume of hydrochloric acid ($d_{20} = 1,18$ g/ml) with one volume of water.

4.2. *Dilute hydrochloric acid solution (HCl), about 0,5 mol/l:*

Mix one volume of hydrochloric acid ($d_{20} = 1,18$ g/ml) with 20 volumes of water.

4.3. *Lanthanum salt solutions (10 g of La per litre)*

This reagent is used for determinations of cobalt, iron, manganese and zinc. It can be prepared either:

(a) with lanthanum oxide dissolved in hydrochloric acid (4.1). Place 11,73 g of lanthanum oxide (La_2O_3) in 150 ml of water in a one litre volumetric flask and add 120 ml of 6 mol/l hydrochloric acid (4.1). Allow to dissolve and then make up to 1 litre with water and mix thoroughly. This solution is approximately 0,5 mol/l in hydrochloric acid

(b) or with solutions of lanthanum chloride, sulphate or nitrate. Dissolve 26,7 g of lanthanum chloride heptahydrate ($\text{LaCl}_3 \cdot 7\text{H}_2\text{O}$) or 31,2 g of lanthanum nitrate hexahydrate [$\text{La}(\text{NO}_3)_3 \cdot 6\text{H}_2\text{O}$] or 26,2 g of lanthanum sulphate nonahydrate [$\text{La}_2(\text{SO}_4)_3 \cdot 9\text{H}_2\text{O}$] in 150 ml of water, then add 85 ml of 6 mol/l hydrochloric acid (4.1). Allow to dissolve and then make up to 1 litre with water. Mix thoroughly. This solution is approximately 0,5 mol/l in hydrochloric acid.

4.4. *Calibration solutions*

For the preparation of these, see the individual determination Method for each micro-nutrient.

5. Apparatus

Atomic absorption spectrometer fitted with sources emitting radiation characteristic of the micro-nutrients to be determined.

The analyst must follow the manufacturer's instructions and be familiar with the apparatus. The apparatus must allow background correction so that it can be used whenever necessary (Co and Zn). The gases to be used are air and acetylene.

6. Preparation of the solution to be analysed6.1. *Preparation of extract solutions of the micro-nutrients to be determined.*

See Methods 9.1 and/or 9.2 and, if appropriate, 9.3.

6.2. *Treatment of the test solution*

Dilute an aliquot portion of the extract obtained by Method 9.1, 9.2 or 9.3 with water and/or hydrochloric acid (4.1) or (4.2) so as to obtain, in the final solution for measurement, a concentration of the element to be determined that is appropriate to the calibration range used (7.2) and a hydrochloric acid concentration of at least 0,5 mol/l and not more than 2,5 mol/l. This operation may require one or more successive dilutions.

Take an aliquot portion of the final solution obtained by dilution of the extract, let (a) be its volume in ml, and pour into a 100 ml volumetric flask. When determining the cobalt, iron, manganese or zinc content, add 10 ml of the lanthanum salt solution (4.3). Make up to volume with the 0,5 mol/l hydrochloric acid solution (4.2) and mix thoroughly. This is the final solution for measurement. Let D be the dilution factor.

▼ B**7. Procedure****7.1. Preparation of a blank solution**

Prepare a blank solution by repeating the whole procedure from the extraction stage, omitting only the test sample of fertiliser.

7.2. Preparation of calibration solutions

From the working calibration solution prepared using the Method given for each individual micro-nutrient, prepare in 100 ml volumetric flasks a series of at least five calibration solutions of increasing concentration within the optimum measuring range of the spectrometer. If necessary, adjust the concentration of hydrochloric acid to bring it as close as possible to that of the diluted test solution (6.2). For determining cobalt, iron, manganese or zinc, add 10 ml of the same lanthanum salt solution (4.3) as used in 6.2. Make up to volume with the 0,5 mol/l hydrochloric acid solution (4.2) and mix thoroughly.

7.3. Determination

Prepare the spectrometer (5) for the determination and adjust to the wavelength given in the Method for the individual micro-nutrient concerned.

Spray three times in succession the calibration solutions (7.2), the test solution (6.2) and the blank solution (7.1), noting each result and flushing the instrument with distilled water between individual sprayings.

Construct the calibration curve by plotting the average spectrometer reading for each calibration solution (7.2) along the ordinate and the corresponding concentration of the element, expressed in µg/ml, along the abscissa.

From this curve, determine the concentrations of the relevant micro-nutrient in the test solution x_s (6.2) and in the blank solution x_b (7.1), expressing these concentrations in µg per ml.

8. Expression of results

The percentage of micro-nutrient (E) in the fertiliser is equal to:

$$E (\%) = [(x_s - x_b) \times V \times D] / (M \times 10^4)$$

If Method 9.3 has been used:

$$E (\%) = [(x_s - x_b) \times V \times 2D] / (M \times 10^4)$$

Where

E is the amount of the micro-nutrient determined, expressed as a percentage of the fertiliser;

x_s is the concentration of the test solution (6.2), in µg/ml;

x_b is the concentration of the blank solution (7.1), in µg/ml;

V is the volume of the extract obtained by Method 9.1 or 9.2, in ml;

D is the factor corresponding to the dilution carried out in 6.2;

M is the mass of the test sample taken in accordance with Method 9.1 or 9.2, in grams.

▼B

Calculation of dilution factor D:

If (a1), (a2), (a3),..., (ai) and (a) are the aliquot portions and (v1), (v2), (v3),..., (vi) and (100) are the volumes in ml corresponding to their respective dilutions, the dilution factor D will be equal to:

$$D = (v1/a1) \times (v2/a2) \times (v3/a3) \times \dots \times (vi/ai) \times (100/a)$$

Method 9.5

Determination of boron in fertiliser extracts by means of spectrometry with azomethine-H

1. Scope

This Method describes a procedure for determining boron in fertiliser extracts.

2. Field of application

This procedure is applicable to analysing samples of fertilisers extracted by Methods 9.1 and 9.2 for which a declaration of total and/or water-soluble boron is required by Annex I to this Regulation.

3. Principle

In an azomethine-H solution, borate ions form a yellow complex the concentration of which is determined by molecular absorption spectrometry at 410 nm. Interfering ions are masked with EDTA.

4. Reagents

4.1. EDTA buffer solution

Place in a 500 ml volumetric flask containing 300 ml of water:

- 75 g of ammonium acetate ($\text{NH}_4\text{OOCCH}_3$);
- 10 g of disodium salt of ethylene diamine tetraacetic acid (Na_2EDTA);
- 40 ml of acetic acid (CH_3COOH , $d_{20} = 1,05$ g/ml).

Make up to volume with water and mix thoroughly. The pH of the solution, checked by means of a glass electrode, must be $4,8 \pm 0,1$.

4.2. Azomethine-H solution

Place in a 200 ml volumetric flask

- 10 ml of the buffer solution (4.1);
- 400 mg of azomethine-H ($\text{C}_{17}\text{H}_{12}\text{NNaO}_8\text{S}_2$);
- 2 g of absorbic acid ($\text{C}_6\text{H}_8\text{O}_6$);
- Make up to volume and mix thoroughly. Do not prepare large quantities of this reagent as it is stable for only a few days.

4.3. Boron calibration solutions

4.3.1. Boron stock solution (100 µg/ml)

Dissolve 0,5719 g of boric acid (H_2BO_3) in water in a 1 000 ml volumetric flask. Make up to volume with water and mix thoroughly. Transfer to a plastic bottle for storage in a refrigerator.

4.3.2. Boron working solution (10 µg/ml)

Place 50 ml of stock solution (4.3.1) in a 500 ml volumetric flask. Make up to volume with water and mix thoroughly.

▼ B**5. Apparatus**

Spectrometer fitted for molecular absorption with cells having a 10 mm optical path and set to a wavelength of 410 nm.

6. Preparation of the solution to be analysed**6.1. Preparation of the boron solution**

See Methods 9.1 and/or 9.2 and, if appropriate, 9.3.

6.2. Preparation of the test solution

Dilute an aliquot portion of extract (6.1) to obtain a boron concentration as specified in 7.2. Two successive dilutions may be necessary. Let D be the dilution factor.

6.3. Preparation of the correction solution

If the test solution (6.2) is coloured, prepare a corresponding correction solution by placing in a plastic flask 5 ml of test solution (6.2), 5 ml of EDTA buffer solution (4.1) and 5 ml of water and mix thoroughly.

7. Procedure**7.1. Preparation of the blank solution**

Prepare a blank solution by repeating the whole procedure from the extraction stage, omitting only the test sample of fertiliser.

7.2. Preparation of the calibration solutions

Transfer 0, 5, 10, 15, 20 and 25 ml of the working calibration solution (4.3.3) to a series of 100 ml volumetric flasks. Make up to 100 ml with water and mix thoroughly. These solutions contain between 0 and 2,5 µg/ml of boron.

7.3. Colour development

Transfer 5 ml of the calibration solutions (7.2), test solutions (6.2) and blank (7.1) to a series of plastic flasks. Add 5 ml of the EDTA buffer solution (4.1). Add 5 ml of the azomethine-H solution (4.2).

Mix thoroughly and allow the colour to develop in the dark for 2¹/₂ to three hours.

7.4. Determination

Measure the absorbance of the solutions obtained at 7.3 and if appropriate the correction solution (6.3) against water at a wavelength of 410 nm. Rinse the cells with water before each new reading.

8. Expression of results

Plot a calibration curve of the concentration of the calibration solutions (7.2) along the abscissa and the absorbance given by the spectrometer (7.4) along the ordinate.

Read off the calibration curve the concentration of boron in the blank (7.1), the concentration of boron in the test solution (6.2) and, if the test solution is coloured, the corrected concentration of the test solution. To calculate the latter, subtract the absorbance of the correction solution (6.3) from the absorbance of the test solution (6.2) and determine the corrected concentration of the test solution. Note the concentration of the test solution (6.2), with or without correction, $X(x_s)$ and of the blank (x_b).

▼B

The percentage of boron in the fertiliser is given by:

$$B \% = [(x_s - x_b) \times V \times D] / (M \times 10^4)$$

If Method 9.3 is used:

$$B \% = [(x_s - x_b) \times V \times 2D] / (M \times 10^4)$$

where

B is the quantity of boron expressed as a percentage of the fertiliser;

x_s is the concentration ($\mu\text{g/ml}$) in the test solution (6.2), with or without correction;

x_b is the concentration ($\mu\text{g/ml}$) in the blank (7.1);

V is the volume in ml of extract obtained in accordance with Method 9.1 or 9.2;

D is the factor corresponding to the dilution carried out in 6.2;

M is the mass in grams of the test sample taken in accordance with Method 9.1 or 9.2.

Calculation of the dilution factor D: if (a1) and (a2) are successive aliquot portions and (v1) and (v2) are the volumes corresponding to their respective dilutions, the dilution factor D is given by:

$$D = (v1/a1) \times (v2/a2)$$

Method 9.6

Determination of cobalt in fertiliser extracts by atomic absorption spectrometry

1. Scope

This Method describes a procedure for determining cobalt in fertiliser extracts.

2. Field of application

This Procedure is applicable to analysing samples of fertilisers extracted by Methods 9.1 and 9.2 for which a declaration of total and/or water-soluble cobalt is required by Annex I E of this Regulation.

3. Principle

After suitable treatment and dilution of the extracts, the cobalt content is determined by atomic absorption spectrometry.

4. Reagents

4.1. Hydrochloric acid solution, about 6 mol/l

See Method 9.4 (4.1).

4.2. Hydrochloric acid solution, about 0,5 mol/l

See Method 9.4 (4.2).

4.3. Lanthanum salt solutions (10 g of La per litre)

See Method 9.4 (4.3).

▼B4.4. *Cobalt calibration solutions*

4.4.1. Cobalt stock solution (1 000 µg/ml)

In a 250 ml beaker, weigh to the nearest 0,1 mg, 1 g of cobalt, add 25 ml of 6 mol/l hydrochloric acid (4.1) and heat on a hotplate until the cobalt is completely dissolved. When cool, transfer quantitatively to a 1 000 ml volumetric flask. Make up to volume with water and mix thoroughly.

4.4.2. Cobalt working solution (100 µg/ml)

Place 10 ml of the stock solution (4.4.1) in a 100 ml volumetric flask. Make up to volume with 0,5 mol/l hydrochloric acid solution (4.2) and mix thoroughly.

5. **Apparatus**

Atomic absorption spectrometer: see Method 9.4 (5). The instrument must be equipped with a source of rays characteristic of cobalt (240,7 nm). The spectrometer must allow background correction to be made.

6. **Preparation of the solution to be analysed**6.1. *Cobalt extract solution*

See Methods 9.1 and/or 9.2 and, if appropriate, 9.3.

6.2. *Preparation of the test solution*

See Method 9.4 (6.2). The test solution must contain 10 % (v/v) of a lanthanum salt solution (4.3).

7. **Procedure**7.1. *Preparation of blank solution*

See Method 9.4 (7.1). The blank must contain 10 % (v/v) of the lanthanum salt solution used in 6.2.

7.2. *Preparation of calibration solutions*

See Method 9.4 (7.2).

For an optimum determination range of 0 to 5 µg/ml of cobalt, place 0, 0,5, 1, 2, 3, 4 and 5 ml respectively of working solution (4.4.2) in a series of 100 ml volumetric flasks. If necessary adjust the hydrochloric acid concentration as closely as possible to that of the test solution. Add to each flask 10 ml of the lanthanum salt solution used in 6.2. Make up to 100 ml with 0,5 mol/l hydrochloric acid solution (4.2) and mix thoroughly. These solutions contain 0, 0,5, 1, 2, 3, 4 and 5 µg/ml respectively of cobalt.

7.3. *Determination*

See Method 9.4 (7.3). Prepare the spectrometer (5) for measurement at a wavelength of 240,7 nm.

8. **Expression of results**

See Method 9.4 (8).

The percentage of cobalt in the fertiliser is given by:

$$\text{Co \%} = [(x_s - x_b) \times V \times D]/(M \times 10^4)$$

▼ B

If Method 9.3 is used:

$$Co \% = [(x_s - x_b) \times V \times 2D] / (M \times 10^4)$$

where

Co is the quantity of cobalt expressed as a percentage of the fertiliser;

x_s is the concentration in $\mu\text{g/ml}$ of the test solution (6.2);

x_b is the concentration in $\mu\text{g/ml}$ of the blank solution (7.1);

V is the volume in ml of extract obtained in accordance with Method 9.1 or 9.2;

D is the factor corresponding to the dilution carried out in 6.2;

M is the mass in grams of the test sample taken in accordance with Method 9.1 or 9.2.

Calculation of the dilution factor D: if (a_1) , (a_2) , (a_3) , ..., (a_i) and (a) are aliquot portions and (v_1) , (v_2) , (v_3) , ..., (v_i) and (100) are the volumes in ml corresponding to their respective dilutions, the dilution factor D is given by:

$$D = (v_1/a_1) \times (v_2/a_2) \times (v_3/a_3) \times \dots \times (v_i/a_i) \times (100/a)$$

Method 9.7

Determination of copper in fertiliser extracts by atomic absorption spectrometry

1. Scope

This Method describes a procedure for determining copper in fertiliser extracts.

2. Field of application

This procedure is applicable to analysing samples of fertilisers extracted by Methods 9.1 and 9.2 for which a declaration of total and/or water-soluble copper is required by Annex I E to this Regulation.

3. Principle

After suitable treatment and dilution of the extracts, the copper content is determined by atomic absorption spectrometry.

4. Reagents

4.1. Hydrochloric acid solution, about 6 mol/l

See Method 9.4 (4.1).

4.2. Hydrochloric acid solution, about 0,5 mol/l

See Method 9.4 (4.2).

4.3. Hydrogen peroxide solution (30 % H_2O_2 , $d_{20} = 1,11 \text{ g/ml}$), free from micro-nutrients

4.4. Copper calibration solutions

4.4.1. Copper stock solution (1 000 $\mu\text{g/ml}$)

In a 250 ml beaker, weigh to the nearest 0,1 mg, 1 g of copper, add 25 ml of 6 mol/l hydrochloric acid (4.1), add 5 ml hydrogen peroxide solution (4.3) and heat on a hotplate until the copper is completely dissolved. Transfer quantitatively to a 1 000 ml volumetric flask. Make up to volume with water and mix thoroughly.

▼B

4.4.2. Copper working solution (100 µg/ml)

Place 20 ml of the stock solution (4.4.1) in a 200 ml volumetric flask. Make up to volume with 0,5 mol/l hydrochloric acid solution (4.2) and mix thoroughly.

5. **Apparatus**

Spectrometer equipped for atomic absorption: see Method 9.4 (5). The instrument must be fitted with a source of rays characteristics of copper (324,8 nm).

6. **Preparation of the solution to be analysed**6.1. *Copper extract solution*

See Methods 9.1 and/or 9.2 and, if appropriate, 9.3.

6.2. *Preparation of the test solution*

See Method 9.4 (6.2).

7. **Procedure**7.1. *Preparation of blank solution*

See Method 9.4 (7.1).

7.2. *Preparation of calibration solutions*

See Method 9.4 (7.2).

For an optimum determination range of 0 to 5 µg/ml of copper, place 0, 0,5, 1, 2, 3, 4 and 5 ml respectively of working solution (4.4.2) in a series of 100 ml volumetric flasks. If necessary adjust the hydrochloric acid concentration as closely as possible to that of the test solution (6.2). Make up to 100 ml with 0,5 mol/l hydrochloric acid solution (4.2) and mix thoroughly. These solutions contain 0, 0,5, 1, 2, 3, 4 and 5 µg/ml respectively of copper.

7.3. *Determination*

See Method 9.4 (7.3). Prepare the spectrometer (5) for measurement at a wavelength of 324,8 nm.

8. **Expression of results**

See Method 9.4 (8).

The percentage of copper in the fertiliser is given by:

$$\text{Cu \%} = [(x_s - x_b) \times V \times D]/(M \times 10^4)$$

If Method 9.3 is used:

$$\text{Cu \%} = [(x_s - x_b) \times V \times 2D]/(M \times 10^4)$$

where

Cu is the quantity of copper expressed as a percentage of the fertiliser;

x_s is the concentration in µg/ml of the test solution (6.2);

x_b is the concentration in µg/ml of the blank solution (7.1);

V is the volume in ml of extract obtained in accordance with Method 9.1 or 9.2;

D is the factor corresponding to the dilution carried out in 6.2;

M is the mass in grams of the test sample taken in accordance with Method 9.1 or 9.2.

▼B

Calculation of the dilution factor D: if (a1), (a2), (a3),..., (ai) and (a) are aliquot portions and (v1), (v2), (v3),..., (vi) and (100) are the volumes in ml corresponding to their respective dilutions, the dilution factor D is given by:

$$D = (v1/a1) \times (v2/a2) \times (v3/a3) \times \dots \times (vi/ai) \times (100/a)$$

Method 9.8**Determination of iron in fertiliser extracts by atomic absorption spectrometry****1. Scope**

This Method describes a procedure for determining iron in fertiliser extracts.

2. Field of application

This procedure is applicable to analysing samples of fertilisers extracted by Methods 9.1 and 9.2 for which a declaration of total and/or water-soluble iron is required by Annex 1E of this Regulation.

3. Principle

After suitable treatment and dilution of the extracts, the iron content is determined by atomic absorption spectrometry.

4. Reagents4.1. *Hydrochloric acid solution, about 6 mol/l*

See Method 9.4 (4.1).

4.2. *Hydrochloric acid solution, about 0,5 mol/l*

See Method 9.4 (4.2).

4.3. Hydrogen peroxide solution (30 % H₂O₂, d₂₀ = 1,11 g/ml), free from micro-nutrients4.4. *Lanthanum salt solutions (10 g of La per litre)*

See Method 9.4 (4.3).

4.5. *Iron calibration solutions*

4.5.1. Iron stock solution (1 000 µg/ml)

In a 500 ml beaker, weigh to the nearest 0,1 mg, 1 g of iron wire, add 200 ml of 6 mol/l hydrochloric acid (4.1) and 15 ml of hydrogen peroxide solution (4.3). Heat on a hotplate until the iron is completely dissolved. When cool, transfer quantitatively to a 1 000 ml volumetric flask. Make up to volume with water and mix thoroughly.

4.5.2. Iron working solution (100 µg/ml)

Place 20 ml of the stock solution (4.5.1) in a 200 ml volumetric flask. Make up to volume with 0,5 mol/l hydrochloric acid solution (4.2) and mix thoroughly.

5. Apparatus

Atomic absorption spectrometer: see Method 9.4 (5). The instrument must be fitted with a source of rays characteristic of iron (248,3 nm).

6. Preparation of the solution to be analysed6.1. *Iron extract solution*

See Methods 9.1 and/or 9.2 and, if appropriate, 9.3.

▼B6.2. *Preparation of the test solution*

See Method 9.4 (6.2). The test solution must contain 10 % (v/v) of a lanthanum salt solution.

7. **Procedure**7.1. *Preparation of blank solution*

See Method 9.4 (7.1). The test solution must contain 10 % (v/v) of the lanthanum salt solution used in 6.2.

7.2. *Preparation of calibration solutions*

See Method 9.4 (7.2).

For an optimum determination range of 0 to 10 µg/ml of iron, place 0, 2, 4, 6, 8 and 10 ml respectively of working solution (4.5.2) in a series of 100 ml volumetric flasks. If necessary adjust the hydrochloric acid concentration as closely as possible to that of the test solution. Add 10 ml of the lanthanum salt solution used in 6.2. Make up to volume with 0,5 mol/l hydrochloric acid solution (4.2) and mix thoroughly. These solutions contain 0, 2, 4, 6, 8 and 10 µg/ml respectively of iron.

7.3. *Determination*

See Method 9.4 (7.3). Prepare the spectrometer (5) for measurement at a wavelength of 248,3 nm.

8. **Expression of results**

See Method 9.4 (8).

The percentage of iron in the fertiliser is given by:

$$\text{Fe \%} = [(x_s - x_b) \times V \times D] / (M \times 10^4)$$

If Method 9.3 is used:

$$\text{Fe \%} = [(x_s - x_b) \times V \times 2D] / (M \times 10^4)$$

where

Fe is the quantity of iron expressed as a percentage of the fertiliser;

x_s is the concentration in µg/ml of the test solution (6.2);

x_b is the concentration in µg/ml of the blank solution (7.1);

V is the volume in ml of extract obtained in accordance with Method 9.1 or 9.2;

D is the factor corresponding to the dilution carried out in 6.2;

M is the mass in grams of the test sample taken in accordance with Method 9.1 or 9.2.

Calculation of the dilution factor D: if (a1), (a2), (a3),..., (ai) and (a) are aliquot portions and (v1), (v2), (v3),..., (vi) and (100) are the volumes in ml corresponding to their respective dilutions, the dilution factor D is given by:

$$D = (v1/a1) \times (v2/a2) \times (v3/a3) \times \dots \times (vi/ai) \times (100/a)$$



Method 9.9

Determination of manganese in fertiliser extracts by atomic absorption spectrometry**1. Scope**

This Method describes a procedure for determining manganese in fertiliser extracts.

2. Field of application

This procedure is applicable to analysing samples of fertilisers extracted by Methods 9.1 and 9.2 for which a declaration of total and/or water-soluble manganese is required by Annex I E of this Regulation.

3. Principle

After suitable treatment and dilution of the extracts, the manganese level is determined by atomic absorption spectrometry.

4. Reagents4.1. *Hydrochloric acid solution, about 6 mol/l*

See Method 9.4 (4.1).

4.2. *Hydrochloric acid solution, about 0,5 mol/l*

See Method 9.4 (4.2).

4.3. *Lanthanum salt solutions (10 g of La per litre)*

See Method 9.4 (4.3).

4.4. *Manganese calibration solutions*

4.4.1. Manganese stock solution (1 000 µg/ml)

In a 250 ml beaker, weigh to the nearest 0,1 mg, 1 g of manganese, add 25 ml of 6 mol/l hydrochloric acid (4.1). Heat on a hotplate until the manganese is completely dissolved. When cool, transfer quantitatively to a 1 000 ml volumetric flask. Make up to volume with water and mix thoroughly.

4.4.2. Manganese working solution (100 µg/ml)

Dilute 20 ml of the stock solution (4.4.1) in the 0,5 mol/l hydrochloric acid solution (4.2) in a 200 ml volumetric flask. Make up to volume with 0,5 mol/l hydrochloric acid solution (4.2) and mix thoroughly.

5. Apparatus

Atomic absorption spectrometer: see Method 9.4 (5). The instrument must be fitted with a source of lines characteristic of manganese (279,6 nm).

6. Preparation of the solution to be analysed6.1. *Manganese extract solution*

See Methods 9.1 and/or 9.2 and, if appropriate, 9.3.

6.2. *Preparation of the test solution*

See Method 9.4 (6.2). The test solution must contain 10 % by volume of lanthanum salt solution (4.3).

7. Procedure7.1. *Preparation of blank solution*

See Method 9.4 (7.1). The test solution must contain 10 % by volume of the lanthanum salt solution used in 6.2.

▼B**7.2. Preparation of calibration solutions**

See Method 9.4 (7.2).

For an optimum determination range of 0 to 5 µg/ml of manganese, place 0, 0,5, 1, 2, 3, 4 and 5 ml respectively of working solution (4.4.2) in a series of 100 ml volumetric flasks. Where necessary adjust the hydrochloric acid concentration to bring it as close as possible to that of the test solution. To each flask, add 10 ml of the lanthanum salt solution used in 6.2. Make up to 100 ml with 0,5 mol/l hydrochloric acid solution (4.2) and mix thoroughly. These solutions contain 0, 0,5, 1, 2, 3, 4 and 5 µg/ml respectively of manganese.

7.3. Determination

See Method 9.4 (7.3). Prepare the spectrometer (5) for measurement at a wavelength of 279,6 nm.

8. Expression of results

See Method 9.4 (8).

The percentage of manganese in the fertiliser is as follows:

$$\text{Mn \%} = [(x_s - x_b) \times V \times D]/(M \times 10^4)$$

If Method 9.3 is used:

$$\text{Mn \%} = [(x_s - x_b) \times V \times 2D]/(M \times 10^4)$$

where

Mn is the quantity of manganese expressed as a percentage of the fertiliser;

x_s is the concentration in µg/ml of the test solution (6.2);

x_b is the concentration in µg/ml of the blank solution (7.1);

V is the volume in ml of extract obtained in accordance with Method 9.1 or 9.2;

D is the factor corresponding to the dilution carried out in 6.2;

M is the mass in grams of the test sample taken in accordance with Method 9.1 or 9.2.

Calculation of the dilution factor D: if (a1), (a2), (a3),..., (ai) and (a) are aliquot portions and (v1), (v2), (v3),..., (vi) and (100) are the volumes in ml corresponding to their respective dilutions, the dilution factor D will be equal to:

$$D = (v1/a1) \times (v2/a2) \times (v3/a3) \times \dots \times (vi/ai) \times (100/a)$$

Method 9.10**Determination of molybdenum in fertiliser extracts by spectrometry of a complex with ammonium thiocyanate****1. Scope**

This Method describes a procedure for determining molybdenum in fertiliser extracts.

2. Field of application

This procedure is applicable to analysing samples of fertilisers extracted by Methods 9.1 and 9.2 for which a declaration of total and/or water-soluble molybdenum is required by Annex I E to this Regulation.

▼ B**3. Principle**

Molybdenum (V) forms a complex $[\text{MoO}(\text{SCN})_5]$ —in an acid medium with SCN^- ions.

The complex is extracted with n-butyl acetate. Interfering ions such as those of iron remain in the aqueous phase. The yellow-orange colour is determined by molecular absorption spectrometry at 470 nm.

4. Reagents**4.1. Dilute hydrochloric acid solution (HCl), about 6 mol/l**

See Method 9.4 (4.1).

4.2. Copper solution (70 mg/l) in 1,5 mol/l hydrochloric acid

Dissolve 275 mg of copper sulphate ($\text{CuSO}_4 \cdot 5\text{H}_2\text{O}$) weighed to within 0,1 mg in 250 ml of the 6 mol/l hydrochloric acid solution (4.1) in a 1 000 ml volumetric flask. Make up to volume with water and mix thoroughly.

4.3. Ascorbic acid solution (50 g/l)

Dissolve 50 g of ascorbic acid ($\text{C}_6\text{H}_8\text{O}_6$) in water in a 1 000 ml volumetric flask. Make up to volume with water, mix thoroughly and keep in a refrigerator.

4.4. n-butyl acetate**4.5. Ammonium thiocyanate solution, 0,2 mol/l**

Dissolve 15,224 g of NH_4SCN in water in a 1 000 ml volumetric flask. Make up to volume with water; mix thoroughly and store in a dark-coloured bottle.

4.6. Stannous chloride solution (50 g/l) in 2 mol/l hydrochloric acid

This solution must be perfectly clear and prepared immediately before use. Very pure stannous chloride must be used otherwise the solution will not be clear.

To prepare 100 ml of solution, dissolve 5 g of ($\text{SnCl}_2 \cdot 2\text{H}_2\text{O}$) in 35 ml of 6 mol/l HCl solution (4.1). Add 10 ml of the copper solution (4.2). Make up to volume with water and mix thoroughly.

4.7. Molybdenum calibration solutions**4.7.1. Molybdenum stock solution (500 µg/ml)**

Dissolve 0,920 g of ammonium molybdate $[(\text{NH}_4)_6\text{Mo}_7\text{O}_{24} \cdot 4\text{H}_2\text{O}]$ weighed to within 0,1 mg in the 6 mol/l hydrochloric acid (4.1) in a 1 000 ml volumetric flask. Make up to volume with that solution and mix thoroughly.

4.7.2. Molybdenum intermediate solution (25 µg/ml)

Place 25 ml of the stock solution (4.7.1) in a 500 ml volumetric flask. Make up to volume with 6 mol/l hydrochloric acid (4.1) and mix thoroughly.

4.7.3. Molybdenum working solution (2,5 µg/ml)

Place 10 ml of the intermediate solution (4.7.2) in a 100 ml volumetric flask. Make up to volume with 6 mol/l hydrochloric acid (4.1) and mix thoroughly.

5. Apparatus**5.1. Spectrometer fitted for molecular absorption with cuvettes having a 20 mm optical path and set to a wavelength of 470 nm**

▼B

5.2. 200 or 250 ml separating funnels

6. **Preparation of the solution to be analysed**

6.1. *Molybdenum extract solution*

See Methods 9.1 and/or 9.2 and, if appropriate, 9.3.

6.2. *Preparation of the test solution*

Dilute an aliquot portion of the extract (6.1) with 6 mol/l hydrochloric acid solution (4.1) so as to obtain an appropriate molybdenum concentration. Let D be the dilution factor.

Take an aliquot portion (a) from the extract solution containing 1 to 12 µg molybdenum and place it in the separating funnel (5.2). Make up to 50 ml with the 6 mol/l hydrochloric acid solution (4.1).

7. **Procedure**

7.1. *Preparation of the blank solution*

Prepare a blank solution by repeating the whole procedure from the extraction stage, omitting only the test sample of fertiliser.

7.2. *Preparation of the series of calibration solutions*

Prepare a series of at least six calibration solutions of increasing concentration corresponding to the optimum response range of the spectrometer.

For the interval 0-12,5 µg molybdenum, place 0, 1, 2, 3, 4 and 5 ml respectively of working solution (4.7.3) in the separating funnels (5.2). Make up to 50 ml with 6 mol/l hydrochloric acid (4.1). The funnels contain respectively 0, 2,5, 5, 7,5, 10 and 12,5 µg molybdenum.

7.3. *Development and separation of the complex*

To each separating funnel (6.2, 7.1 and 7.2), add in the following order:

— 10 ml of the copper solution (4.2)

— 20 ml of the ascorbic acid solution (4.3);

mix thoroughly and wait for two or three minutes. Then add:

— 10 ml of n-butyl acetate (4.4), using a precision pipette

— 20 ml of the thiocyanate solution (4.5).

Shake for one minute to extract the complex in the organic phase; allow to precipitate; after the separation of the two phases, draw off the entire aqueous phase and discard it; then wash the organic phase with:

— 10 ml of the stannous chloride solution (4.6).

Shake for one minute. Allow to precipitate and draw off the entire aqueous phase. Collect the organic phase in a test tube; this will make it possible to collect the drops of water in suspension.

7.4. *Determination*

Measure the absorbencies of the solutions obtained at 7.3 at a wavelength of 470 nm using the 0 µg/ml molybdenum calibration solution (7.2) as a reference.

8. **Expression of results**

Construct the calibration curve by plotting the corresponding masses of molybdenum in the calibration solutions (7.2) expressed in µg along the abscissa and the corresponding values of the absorbencies (7.4) given by the spectrometer reading along the ordinate.

▼B

From this curve determine the mass of molybdenum in the test solution (6.2) and the blank solution (7.1). These masses are designated (x_s) and (x_b) respectively.

The percentage of molybdenum in the fertiliser is:

$$\text{Mo \%} = [(x_s - x_b) \times V/a \times D]/(M \times 10^4)$$

If Method 9.3 is used:

$$\text{Mo \%} = [(x_s - x_b) \times V/a \times 2D]/(M \times 10^4)$$

where

Mo is the quantity of molybdenum expressed as a percentage of the fertiliser;

a is the volume in ml of the aliquot taken from the last dilute solution (6.2);

x_s is the Mo mass in μg in the test solution (6.2);

x_b is the Mo mass in μg in the blank solution (7.1) the volume of which corresponds to the volume (a) of the aliquot of the test solution (6.2);

V is the volume in ml of extract solution obtained in accordance with Method 9.1 or 9.2;

D is the factor corresponding to the dilution performed in 6.2;

M is the mass in grams of the test sample taken in accordance with Method 9.1 or 9.2.

Calculation of the dilution factor D: where (a1), (a2) are successive aliquot portions and (v1), (v2) are the volumes corresponding to their respective dilutions, the dilution factor D will be:

$$D = (v1/a1) \times (v2/a2)$$

Method 9.11

Determination of zinc in fertiliser extracts by atomic absorption spectrometry

1. Scope

This Method describes a procedure for determining zinc in fertiliser extracts.

2. Field of application

This procedure is applicable to analysing samples of fertilisers extracted by Methods 9.1 and 9.2 for which a declaration of total and/or water-soluble zinc is required by Annex I E to this Regulation.

3. Principle

After suitable treatment and dilution of the extracts, the zinc level is determined by atomic absorption spectrometry.

4. Reagents

4.1. Hydrochloric acid solution, about 6 mol/l

See Method 9.4 (4.1).

4.2. Hydrochloric acid solution, about 0,5 mol/l

See Method 9.4 (4.2).

▼B4.3. *Lanthanum salt solutions (10 g of La per litre)*

See Method 9.4 (4.3).

4.4. *Zinc calibration solutions*4.4.1. *Zinc stock solution (1 000 µg/ml)*

In a 1 000 ml volumetric flask, dissolve 1 g of zinc powder or flakes weighed to within 0,1 mg in 25 ml of 6 mol/l hydrochloric acid (4.1). When completely dissolved, make up to volume with water and mix thoroughly.

4.4.2. *Zinc working solution (100 µg/ml)*

In a 200 ml volumetric flask, dilute 20 ml of the stock solution (4.4.1) in 0,5 mol/l hydrochloric acid solution (4.2). Make up to volume with the 0,5 mol/l hydrochloric acid solution (4.2) and mix thoroughly.

5. **Apparatus**

Atomic absorption spectrometer: see Method 9.4 (5). The instrument must be fitted with a source of lines characteristic of zinc (213,8 nm), the spectrometer must allow background correction to be made.

6. **Preparation of the solution to be analysed**6.1. *Zinc extract solution*

See Methods 9.1 and/or 9.2 and, if appropriate, 9.3.

6.2. *Preparation of the test solution*

See Method 9.4 (6.2). The test solution must contain 10 % by volume of lanthanum salt solution (4.3).

7. **Procedure**7.1. *Preparation of blank solution*

See Method 9.4 (7.1). The test solution must contain 10 % by volume of the lanthanum salt solution used in 6.2.

7.2. *Preparation of calibration solutions*

See Method 9.4 (7.2).

For an optimum interval of 0 to 5 µg/ml of zinc, place 0, 0,5, 1, 2, 3, 4 and 5 ml respectively of working solution (4.4.2) in a series of 100 ml volumetric flasks. Where necessary adjust the hydrochloric acid concentration to bring it as close as possible to that of the test solution. To each flask, add 10 ml of the lanthanum salt solution used in 6.2. Make up to 100 ml with 0,5 mol/l hydrochloric acid solution (4.2) and mix thoroughly. These solutions contain 0, 0,5, 1, 2, 3, 4 and 5 µg/ml respectively of zinc.

7.3. *Determination*

See Method 9.4 (7.3). Prepare the spectrometer (5) for measurement at a wavelength of 213,8 nm.

8. **Expression of results**

See Method 9.4 (8).

The percentage of zinc in the fertiliser is as follows:

$$\text{Zn \%} = [(x_s - x_b) \times V \times D]/(M \times 10^4)$$

▼B

If Method 9.3 is used:

$$\text{Zn \%} = [(x_s - x_b) \times V \times 2D] / (M \times 10^4)$$

where

Zn is the quantity of zinc expressed as a percentage of the fertiliser;

x_s is the concentration in $\mu\text{g/ml}$ of the test solution (6.2);

x_b is the concentration in $\mu\text{g/ml}$ of the blank solution (7.1);

V is the volume in ml of extract obtained in accordance with Method 9.1 or 9.2;

D is the factor corresponding to the dilution carried out in 6.2;

M is the mass in grams of the test sample taken in accordance with Method 9.1 or 9.2.

Calculation of the dilution factor D: if (a1), (a2), (a3),..., (ai) and (a) are aliquot portions and (v1), (v2), (v3),..., (vi) and (100) are the volumes in ml corresponding to their respective dilutions, the dilution factor D will be equal to:

$$D = (v1/a1) \times (v2/a2) \times (v3/a3) \times \dots \times (vi/ai) \times (100/a)$$

Methods 10

Micro-nutrients at a concentration greater than 10 %

Method 10.1

Extraction of total micro-nutrients

1. Scope

This Method defines the procedure for extracting the following micro-nutrients: total boron, total cobalt, total copper, total iron, total manganese, total molybdenum and total zinc. The aim is to carry out the minimum number of extractions, making use wherever possible of the same extract to determine the total level of each of the micro-nutrients listed above.

2. Field of application

This procedure concerns Community fertilisers covered by Annex I E to this Regulation containing one or more of the following micro-nutrients: boron, cobalt, copper, iron, manganese, molybdenum and zinc. It is applicable to each micro-nutrient the declared content of which is more than 10 %.

3. Principle

Dissolution in boiling dilute hydrochloric acid.

Note

The extraction is empirical and may not be quantitative depending on the product or the other constituents of the fertiliser. In particular, in the case of certain manganese oxides, the quantity extracted may be substantially smaller than the total quantity of manganese which the product contains. It is the responsibility of the fertiliser manufacturers to ensure that the declared content actually corresponds to the quantity extracted under the conditions pertaining to the method.

4. Reagents

4.1. Dilute hydrochloric acid (HCl) solution, about 6 mol/l

Mix 1 volume of hydrochloric acid ($d_{20} = 1,18 \text{ g/ml}$) with 1 volume of water.

▼B

- 4.2. Concentrated ammonia solution (NH_4OH , $d_{20} = 0,9$ g/ml)

5. **Apparatus**

- 5.1. Electric hotplate with variable temperature control

- 5.2. pH meter

Note

Where the boron content of an extract is to be determined, do not use borosilicate glassware. As the Method involves boiling, teflon or silica is preferable. Rinse the glassware thoroughly if it has been washed in detergents containing borates.

6. **Preparation of the sample**

See Method 1.

7. **Procedure**

7.1. *Test sample*

Take a quantity of fertiliser weighing 1 or 2 g depending on the declared content of element in the product. The following table shall be used to obtain a final solution which, after appropriate dilution, will be within the measuring range for each method. Samples should be weighed to within 1 mg.

Declared content of micro-nutrient in the fertiliser (%)	> 10 < 25	≥ 25
Mass of test sample (g)	2	1
Mass of element in the sample (mg)	> 200 < 500	≥ 250
Volume of extract V (ml)	500	500
Concentration of element in extract (mg/l)	> 400 < 1 000	≥ 500

Place the sample in a 250 ml beaker.

7.2. *Preparation of the solution*

If necessary moisten the sample with a little water, add 10 ml of dilute hydrochloric acid (4.1) per gram of fertiliser carefully, in small amounts, then add about 50 ml of water. Cover the beaker with a watch glass and mix. Bring to the boil on the hotplate and boil for 30 minutes. Allow to cool, stirring occasionally. Transfer quantitatively to a 500 ml volumetric flask. Make up to volume with water and mix thoroughly. Filter through a dry filter into a dry container. Discard the first portion. The extract must be perfectly clear.

It is recommended that the determination be carried out without delay on aliquot portions of the clear filtrate, if not the containers should be stoppered.

Note

Extracts in which the boron content has to be determined: Adjust the pH to between 4 and 6 with concentrated ammonia (4.2).

8. **Determination**

The determination of each micro-nutrient is to be carried out on the aliquot portions indicated in the Method for each individual micro-nutrient.

▼B

Methods 10.5, 10.6, 10.7, 10.9 and 10.10 cannot be used to determine elements present in a chelated or complexed form. In such cases Method 10.3 must be used prior to the determination.

In the case of determination by AAS (Methods 10.8 and 10.11) such treatment may not be necessary.

Method 10.2

Extraction of water-soluble micro-nutrients1. **Scope**

This Method defines the procedure for extracting water-soluble forms of the following micro-nutrients: boron, cobalt, copper, iron, manganese, molybdenum and zinc. The aim is to carry out the minimum number of extractions, making use wherever possible of the same extract to determine the level of each of the micro-nutrients listed above.

2. **Field of application**

This Procedure concerns Community fertilisers covered by Annex I E to this Regulation containing one or more of the following micro-nutrients: boron, cobalt, copper, iron, manganese, molybdenum and zinc. It is applicable to each micro-nutrient the declared content of which is more than 10 %.

3. **Principle**

The micro-nutrients are extracted by shaking the fertiliser in water at 20 °C (± 2) °C.

Note

The extraction is empirical and may or may not be quantitative.

4. **Reagents**4.1. *Dilute hydrochloric acid (HCl) solution, about 6 mol/l*

Mix 1 volume of hydrochloric acid ($d_{20} = 1,18$ g/ml) with 1 volume of water.

5. **Apparatus**

5.1. Rotary shaker set at about 35 to 40 rpm

Note

Where the boron content of the extract is to be determined, do not use borosilicate glassware. Teflon or silica is preferable for this extraction. Rinse the glassware thoroughly if it has been washed in detergents containing borates.

6. **Preparation of the sample**

See Method 1.

7. **Procedure**7.1. *Test sample*

Take a quantity of fertiliser weighing 1 or 2 g depending on the declared content of the product. The following table shall be used to obtain a final solution which, after appropriate dilution, will be within the measuring range for each method. The samples should be weighed to within 1 mg.

▼B

Declared content of micro-nutrient in the fertiliser (%)	> 10 < 25	≥ 25
Mass of test sample (g)	2	1
Mass of element in the sample (mg)	> 200 < 500	≥ 250
Volume of extract V (ml)	500	500
Concentration of element in extract (mg/l)	> 400 < 1 000	≥ 500

Place the sample in a 500 ml flask.

7.2. *Preparation of the solution*

Add about 400 ml of water.

Stopper the flask well. Shake vigorously by hand to disperse the sample, then place the flask on the shaker and shake for 30 minutes.

Make up to volume with water and mix thoroughly.

7.3. *Preparation of the test solution*

Filter immediately into a clean, dry flask. Stopper the flask. Carry out the determination immediately after filtering.

Note

If the filtrate gradually becomes cloudy, make another extraction following 7.1 and 7.2 in a flask of volume V_e . Filter into a calibrated flask of volume W which has previously been dried and has received 5 ml of dilute hydrochloric acid (4.1). Stop the filtration at the exact moment when the calibration mark is reached. Mix thoroughly.

Under these conditions the value of V in the expression of results is:

$$V = V_e \times W / (W - 5)$$

The dilutions in the expression of results depend on this value of V .

8. Determination

The determination of each micro-nutrient is carried out on the aliquot portions indicated in the Method for each individual micro-nutrient.

Methods 10.5, 10.6, 10.7, 10.9 and 10.10 cannot be used to determine elements present in a chelated or complexed form. In such cases Method 10.3 must be used prior to the determination.

In the case of determination by AAS (Methods 10.8 and 10.11) such treatment may not be necessary.

▼B

Method 10.3

Removal of organic compounds from fertiliser extracts1. **Scope**

This Method defines a procedure for removing organic compounds from fertiliser extracts.

2. **Field of application**

This procedure is applicable to analysing samples of fertilisers extracted by Methods 10.1 and 10.2 for which a declaration of total and/or water-soluble element is required by Annex I E to this Regulation.

Note

The presence of small quantities of organic matter usually does not affect determination by means of atomic absorption spectrometry.

3. **Principle**

The organic compounds in an aliquot portion of the extract are oxidised with hydrogen peroxide.

4. **Reagents**4.1. *Dilute hydrochloric acid (HCl) solution, about 0,5 mol/l*

Mix 1 volume of hydrochloric acid ($d_{20} = 1,18$ g/ml) with 20 volumes of water.

4.2. Hydrogen peroxide solution (30 % H_2O_2 , $d_{20} = 1,11$ g/ml), free from micro-nutrients5. **Apparatus**

Electric hotplate with variable temperature control.

6. **Procedure**

Take 25 ml of the extract solution obtained by Method 10.1 or Method 10.2 and place in a 100 ml beaker. In the case of Method 10.2, add 5 ml of the dilute hydrochloric acid solution (4.1). Then add 5 ml of the hydrogen peroxide solution (4.2). Cover with a watch glass. Allow oxidation to occur at room temperature for about one hour, then bring gradually to boiling and boil for half an hour. If necessary, add a further 5 ml of the hydrogen peroxide to the solution once it has cooled. Then boil to remove the excess hydrogen peroxide. Allow to cool and transfer quantitatively to a 50 ml volumetric flask and make up to volume. Filter where necessary.

Account should be taken of this dilution when taking aliquot portions and calculating the percentage of micro-nutrient in the product.

Method 10.4

Determination of micro-nutrients in fertiliser extracts by atomic absorption spectrometry**(general procedure)**1. **Scope**

This document defines a general procedure for determining the levels of iron and zinc in fertiliser extracts by atomic absorption spectrometry.

▼B**2. Field of application**

This procedure is applicable to analysing samples of fertilisers extracted by Methods 10.1 and 10.2 for which a declaration of total and/or water-soluble iron or zinc is required by Annex I E to this Regulation.

Adaptations of this procedure for the various micro-nutrients are detailed in the methods defined specifically for each element.

Note

In most cases the presence of small quantities of organic matter will not affect determinations by atomic absorption spectrometry.

3. Principle

After the extract has been treated where necessary to reduce or eliminate interfering chemical species, the extract is diluted so that its concentration is in the optimum range of the spectrometer at a wavelength suitable for the micro-nutrient to be determined.

4. Reagents**4.1. Dilute hydrochloric acid solution (HCl), about 6 mol/l**

Mix one volume of hydrochloric acid ($d_{20} = 1,18$ g/ml) with one volume of water.

4.2. Dilute hydrochloric acid solution (HCl), about 0,5 mol/l

Mix one volume of hydrochloric acid ($d_{20} = 1,18$ g/ml) with 20 volumes of water.

4.3. Lanthanum salt solutions (10 g of La per litre)

This reagent is used for determinations of iron and zinc. It can be prepared either:

(a) with lanthanum oxide dissolved in hydrochloric acid (4.1). Place 11,73 g of lanthanum oxide (La_2O_3) in 150 ml of water in a one litre volumetric flask and add 120 ml of 6 mol/l hydrochloric acid (4.1). Allow to dissolve and then make up to 1 litre with water and mix thoroughly. This solution is approximately 0,5 mol/l in hydrochloric acid; or

(b) with solutions of lanthanum chloride, sulphate or nitrate. Dissolve 26,7 g of lanthanum chloride heptahydrate ($\text{LaCl}_3 \cdot 7\text{H}_2\text{O}$) or 31,2 g of lanthanum nitrate hexahydrate [$\text{La}(\text{NO}_3)_3 \cdot 6\text{H}_2\text{O}$] or 26,2 g of lanthanum sulphate nonahydrate [$\text{La}_2(\text{SO}_4)_3 \cdot 9\text{H}_2\text{O}$] in 150 ml of water, then add 85 ml of 6 mol/l hydrochloric acid (4.1). Allow to dissolve and then make up to 1 litre with water. Mix thoroughly. This solution is approximately 0,5 mol/l in hydrochloric acid.

4.4. Calibration solutions

For the preparation of these, see the individual determination Method for each micro-nutrient.

5. Apparatus

Atomic absorption spectrometer fitted with sources emitting radiation characteristic of the micro-nutrients to be determined.

The analyst must follow the manufacturer's instructions and be familiar with the apparatus. The apparatus must allow background correction so that it can be used whenever necessary (e.g. Zn). The gases to be used are air and acetylene.

▼B**6. Preparation of the solution to be analysed****6.1. Preparation of extract solutions containing the elements to be determined**

See Methods 10.1 and/or 10.2 and, if appropriate, 10.3.

6.2. Treatment of the test solution

Dilute an aliquot portion of the extract obtained by Method 10.1, 10.2 or 10.3 with water and/or hydrochloric acid (4.1) or (4.2) so as to obtain, in the final solution for measurement, a concentration of the element to be determined that is appropriate to the calibration range used (7.2) and a hydrochloric acid concentration of at least 0,5 mol/l and not more than 2,5 mol/l. This operation may require one or more successive dilutions.

The final solution has to be obtained by placing an aliquot portion of the diluted extract in a 100 ml volumetric flask. Let the volume of this aliquot portion be (a) ml. Add 10 ml of the lanthanum salt solution (4.3). Make up to volume with the 0,5 mol/l hydrochloric acid solution (4.2) and mix thoroughly. Let D be the dilution factor.

7. Procedure**7.1. Preparation of a blank solution**

Prepare a blank solution by repeating the whole procedure from the extraction stage, omitting only the test sample of fertiliser.

7.2. Preparation of calibration solutions

From the working calibration solution prepared using the Method given for each individual micro-nutrient, prepare in 100 ml volumetric flasks a series of at least five calibration solutions of increasing concentration within the optimum measuring range of the spectrometer. If necessary, adjust the concentration of hydrochloric acid to bring it as close as possible to that of the diluted test solution (6.2). When determining iron or zinc, add 10 ml of the same lanthanum salt solution (4.3) as used in 6.2. Make up to volume with the 0,5 mol/l hydrochloric acid solution (4.2) and mix thoroughly.

7.3. Determination

Prepare the spectrometer (5) for the determination and adjust to the wavelength given in the Method for the individual micro-nutrient concerned.

Spray three times in succession the calibration solutions (7.2), the test solution (6.2) and the blank solution (7.1), noting each result and flushing the instrument with distilled water between individual sprayings.

Construct the calibration curve by plotting the average spectrometer reading for each calibration solution (7.2) along the ordinate and the corresponding concentration of the element, expressed in µg/ml, along the abscissa.

From this curve, determine the concentrations of the relevant micro-nutrient in the test solution x_s (6.2) and in the blank solution x_b (7.1), expressing these concentrations in µg per ml.

8. Expression of results

The percentage of micro-nutrient (E) in the fertiliser is given by:

$$E (\%) = [(x_s - x_b) \times V \times D] / (M \times 10^4)$$

▼ B

If Method 10.3 has been used:

$$E (\%) = [(x_s - x_b) \times V \times 2D] / (M \times 10^4)$$

Where

E is the amount of the micro-nutrient determined, expressed as a percentage of the fertiliser;

x_s is the concentration of the test solution (6.2), in $\mu\text{g/ml}$;

x_b is the concentration of the blank solution (7.1), in $\mu\text{g/ml}$;

V is the volume of the extract obtained by Method 10.1 or 10.2, in ml;

D is the factor corresponding to the dilution carried out in 6.2;

M is the mass of the test sample taken in accordance with Method 10.1 or 10.2, in grams.

Calculation of dilution factor D:

If (a1), (a2), (a3),..., (ai) and (a) are the aliquot portions and (v1), (v2), (v3),..., (vi) and (100) are the volumes in ml corresponding to their respective dilutions, the dilution factor D will be equal to:

$$D = (v1/a1) \times (v2/a2) \times (v3/a3) \times \dots \times (vi/ai) \times (100/a)$$

Method 10.5

Determination of boron in fertiliser extracts by means of acidimetric titration

1. Scope

This Method defines a procedure for determining the boron content of fertiliser extracts.

2. Field of application

This procedure is applicable to extracts from samples of fertilisers obtained by Methods 10.1 or Method 10.2 and for which a declaration of total and/or water-soluble boron is required by Annex I E to this Regulation.

3. Principle

A mannitoboric complex is formed by the following reaction of the borate with mannitol:



The complex is titrated with sodium hydroxide solution to a pH of 6,3.

4. Reagents

4.1. Methyl red indicator solution

Dissolve 0,1 g of methyl red ($\text{C}_{15}\text{H}_{15}\text{N}_3\text{O}_2$) in 50 ml of ethanol (95 % in a 100 ml volumetric flask). Make up the volume to 100 ml with water. Mix thoroughly.

4.2. Diluted hydrochloric acid solution, about 0,5 mol

Mix 1 volume of hydrochloric acid HCl ($d_{20} = 1,18 \text{ g/ml}$) with 20 volumes of water.

4.3. Sodium hydroxide solution, about 0,5 mol/l

Must be free of carbon dioxide. Dissolve 20 g of sodium hydroxide (NaOH) in pellet form in a 1 litre volumetric flask containing about 800 ml of boiled water. When the solution has cooled, make up to 1 000 ml with boiled water and mix thoroughly.

▼ B4.4. *Standard sodium hydroxide solution, about 0,025 mol/l*

Must be free of carbon dioxide. Dilute the 0,5 mol/l sodium hydroxide solution (4.3) 20 times with boiled water and mix thoroughly. The value of the solution expressed as boron (B) is to be determined (see Paragraph 9).

4.5. *Boron calibration solution (100 µg/ml B)*

Dissolve 0,5719 g of boric acid (H_3BO_3), weighed to the nearest 0,1 mg, in water in a 1,000 ml volumetric flask. Make up to volume with water and mix thoroughly. Transfer to a plastic bottle for storage in a refrigerator.

4.6. D-mannitol ($C_6H_{14}O_6$) powder

4.7. Sodium chloride (NaCl)

5. **Apparatus**

5.1. pH meter with glass electrode

5.2. Magnetic stirrer

5.3. 400 ml beaker with teflon rod

6. **Preparation of the solution to be analysed**6.1. *Preparation of the boron solution*

See Methods 10.1, 10.2 and, where appropriate, 10.3.

7. **Procedure**7.1. *Test*

Place in a 400 ml beaker (5.3) an aliquot (a) of the extract (6.1) containing 2 to 4 mg B. Add 150 ml of water.

Add several drops of the methyl red indicator solution (4.1).

In the case of extraction with Method 10.2, acidify by adding 0,5 mol/l hydrochloric acid (4.2) up to the point of change of the indicator solution, then add a further 0,5 ml of 0,5 mol/l hydrochloric acid (4.2).

After adding 3 g of sodium chloride (4.7), bring to boiling to drive off the carbon dioxide. Allow to cool. Place the beaker on the magnetic stirrer (5.2) and insert the precalibrated pH meter electrodes (5.1).

Adjust the pH to exactly 6,3, first with the 0,5 mol/l sodium hydroxide solution (4.3), then with the 0,025 mol/l solution (4.4).

Add 20 g of D-mannitol (4.6), dissolve completely and mix thoroughly. Titrate with the 0,025 mol/l sodium hydroxide solution (4.4) to pH 6,3 (at least 1 minute stability). Let X_1 be the volume required.

8. **Blank solution**

Prepare a blank solution by repeating the whole procedure from the preparation of solution stage, omitting only the fertiliser. Let X_0 be the volume required.

9. **Boron (B) value of the sodium hydroxide solution (4.4)**

Pipette 20 ml (2,0 mg B) of the calibration solution (4.5), into a 400 ml beaker and add several drops of methyl red indicator solution (4.1). Add 3 g of sodium chloride (4.7) and the hydrochloric acid solution (4.2) up to the point of change of the indicator solution (4.1).

▼ B

Make up the volume to about 150 ml and bring gradually to the boil so as to eliminate carbon dioxide. Allow to cool. Place the beaker on the magnetic stirrer (5.2), and insert the precalibrated pH meter electrodes (5.1). Adjust the pH to exactly 6,3, first with the 0,5 mol/l sodium hydroxide solution (4.3), then with the 0,025 mol/l solution (4.4).

Add 20 g of D-mannitol (4.6), dissolve completely and mix thoroughly. Titrate with the 0,025 mol/l sodium hydroxide solution (4.4) to pH 6,3 (at least 1 minute stability). Let V_1 be the volume required.

Prepare a blank solution in the same way, substituting 20 ml of water for the calibration solution. Let V_0 be the volume required.

The boron value (F) in mg/ml of the standard NaOH solution (4.4) is as follows:

$$F \text{ (in mg/ml)} = 2/(V_1 - V_0)$$

1 ml of exactly 0,025 mol/l sodium hydroxide solution corresponds to 0,27025 mg B.

10. Expression of results

The percentage of boron in the fertiliser is given by:

$$B \text{ (\%)} = \frac{(X_1 - X_0) \times F \times V}{10 \times a \times M}$$

where

B (%) is the percentage of boron in the fertiliser;

X_1 is the volume, in ml, of the 0,025 mol/l sodium hydroxide solution (4.4); needed for the test solution;

X_0 is the volume, in ml, of the 0,025 mol/l sodium hydroxide solution (4.4); needed for the blank solution;

F is the boron (B) value, in mg/ml, of the 0,025 mol/l sodium hydroxide solution mol/l (4.4);

V is the volume, in ml, of the extract solution obtained in accordance with Method 10.1 or 10.2;

a is the volume, in ml, of the aliquot (7.1) taken from the extract solution (6.1);

M is the mass, in grams, of the test sample taken in accordance with Method 10.1 or 10.2.

Method 10.6

Determination of cobalt in fertiliser extracts by the gravimetric method with 1-nitroso-2-naphthol

1. Scope

This document defines a procedure for determining cobalt in fertiliser extracts.

2. Field of application

This procedure is applicable to extracts from samples of fertilisers obtained by Method 10.1 or Method 10.2 for which a declaration of cobalt content is required by Annex I E to this Regulation.

▼ B**3. Principle**

Cobalt III combines with 1-nitroso-2-naphthol to give a red precipitate $\text{Co}(\text{C}_{10}\text{H}_6\text{ONO})_3, 2\text{H}_2\text{O}$. After the cobalt present in the extract has been brought to the cobalt III state, the cobalt is precipitated in an acetic acid medium by a solution of 1-nitroso-2-naphthol. After filtration, the precipitate is washed and dried to constant mass and then weighed as $\text{Co}(\text{C}_{10}\text{H}_6\text{ONO})_3, 2\text{H}_2\text{O}$.

4. Reagents

4.1. Hydrogen peroxide solution (H_2O_2 , $d_{20} = 1,11 \text{ g/ml}$) 30 %

4.2. *Sodium hydroxide solution, about 2 mol/l*

Dissolve 8 g of sodium hydroxide in pellet form in 100 ml of water.

4.3. *Diluted hydrochloric acid solution, about 6 mol/l*

Mix one volume of hydrochloric acid ($d_{20} = 1,18 \text{ g/ml}$) with 1 volume of water.

4.4. Acetic acid (99,7 % $\text{CH}_3\text{CO}_2\text{H}$) ($d_{20} = 1,05 \text{ g/ml}$)

4.5. *Acetic acid solution (1:2), about 6 mol/l*

Mix one volume of acetic acid (4.4) with 2 volumes of water.

4.6. Solution of 1-nitroso-2-naphthol in 100 ml of acetic acid (4.4). Add 100 ml of lukewarm water. Mix thoroughly. Filter at once. The solution obtained must be used immediately

5. Apparatus

5.1. Filter crucible P 16/ISO 4 793, porosity 4, capacity 30 or 50 ml

5.2. Drying oven at $130 (\pm 2) \text{ }^\circ\text{C}$

6. Preparation of the solution to be analysed

6.1. *Preparation of the cobalt solution*

See Methods 10.1 or 10.2.

6.2. *Preparation of the solution to be analysed*

Place an aliquot of the extract containing not more than 20 mg Co in a 400 ml beaker. If the extract is obtained according to Method 10.2, acidify with five drops of hydrochloric acid (4.3). Add about 10 ml of the hydrogen peroxide solution (4.1). Allow the oxidant to act in the cold state for 15 minutes, then make up to about 100 ml with water. Cover the beaker with a watch glass. Bring the solution to boiling point and allow to boil for about 10 minutes. Cool. Make alkaline with the sodium hydroxide solution (4.2) drop by drop until black cobalt hydroxide begins to precipitate.

7. Procedure

Add 10 ml of acetic acid (4.4) and make up the solution with water to about 200 ml. Heat until boiling. Using a burette, add 20 ml of the 1-nitroso-2-naphthol solution (4.6) drop by drop, stirring constantly. Complete by vigorous stirring to make the precipitate coagulate.

Filter through a previously weighed filter crucible (5.1), taking care not to clog up the crucible. With this in mind, ensure that liquid is left above the precipitate throughout the filtration process.

▼B

Wash the beaker with dilute acetic acid (4.5) to remove all the precipitate, wash the precipitate on the filter with dilute acetic acid (4.5) and then three times with hot water.

Dry in a drying oven (5.2) at 130 (± 2) °C until constant mass is achieved.

8. **Expression of the results**

1 mg of Co (C₁₀H₆ONO)₃, 2H₂O precipitate corresponds to 0,096381 mg Co.

The percentage of Cobalt (Co) in the fertiliser is given by:

$$\text{Co (\%)} = X \times 0,0096381 \times \frac{V \times D}{a \times M}$$

where

X is the mass in mg of the precipitate;

V is the volume in ml of the extract solution obtained in accordance with Method 10.1 or Method 10.2;

a is the volume in ml of the aliquot taken from the last dilution;

D is the dilution factor of this aliquot;

M is the mass in g of the test sample.

Method 10.7

Determination of copper in fertiliser extracts by the titrimetric method

1. **Scope**

This document defines a procedure for determining copper in fertiliser extracts.

2. **Field of application**

This procedure is applicable to extracts from samples of fertilisers obtained by Method 10.1 or Method 10.2 for which a declaration of copper content is required by Annex IE to this Regulation.

3. **Principle**

The cupric ions are reduced in an acidic medium with potassium iodide:

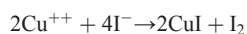

The iodine released in this way is titrated with a standard sodium thiosulphate solution in the presence of starch as an indicator in accordance with:

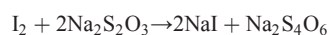

4. **Reagents**

4.1. Nitric acid (HNO₃, d₂₀ = 1,40 g/ml)

4.2. Urea [(NH₂)₂ C = 0]

4.3. *Ammonium bifluoride (NH₄HF₂) solution 10 % w/v*

Keep the solution in a plastic container.

4.4. *Ammonium hydroxide solution (1 + 1)*

Mix 1 volume of ammonia (NH₄OH, d₂₀ = 0,9 g/ml) with 1 volume of water.

▼B4.5. *Sodium thiosulphate standard solution*

Dissolve 7,812 g of sodium thiosulphate pentahydrate ($\text{Na}_2\text{S}_2\text{O}_3\cdot 5\text{H}_2\text{O}$) with water in a 1 litre volumetric flask. This solution must be prepared so that 1 ml = 2 mg Cu. For stabilisation, add several drops of chloroform. The solution must be kept in a glass container and protected from direct light.

4.6. Potassium iodide (KI)

4.7. *Potassium thiocyanate (KSCN) solution (25 % w/v)*

Keep this solution in a plastic flask.

4.8. *Starch solution (about 0,5 %)*

Place 2,5 g of starch in a 600 ml beaker. Add about 500 ml of water. Boil while stirring. Cool to ambient temperature. The solution has a short preservation period. Its preservation can be extended by adding about 10 mg of mercury iodide.

5. **Preparation of the solution to be analysed**

Preparation of the copper solution

See Methods 10.1 and 10.2.

6. **Procedure**6.1. *Preparation of the solution of titration*

Place an aliquot portion of the solution containing not less than 20-40 mg Cu in a 500 ml Erlenmeyer flask.

Drive off any excess oxygen present by boiling briefly. Make up to a volume of about 100 ml water. Add 5 ml of nitric acid (4.1), bring to boiling and allow to boil for about half a minute.

Remove the Erlenmeyer flask from the heating apparatus, add about 3 g of urea (4.2) and resume boiling for about half a minute.

Remove from the heating apparatus and add 200 ml of cold water. Where necessary, cool the contents of the Erlenmeyer flask to ambient temperature.

Gradually add ammonia hydroxide solution (4.4) until the solution becomes blue, then add 1 ml in excess.

Add 50 ml of ammonium bifluoride solution (4.3) and mix.

Add 10 g of potassium iodide (4.6) and dissolve.

6.2. *Titration of the solution*

Place the Erlenmeyer flask on a magnetic stirrer. Insert the rod into the Erlenmeyer flask and adjust the stirrer to the desired speed.

Using a burette, add standard sodium thiosulphate solution (4.5) until the brown colour of the iodine released from the solution becomes less intense.

Add 10 ml of the starch solution (4.8).

Continue to titrate with the sodium thiosulphate solution (4.5) until the purple colour has almost disappeared.

Add 20 ml of the potassium thiocyanate solution (4.7) and continue titration until the violet blue colour has completely disappeared.

Note the volume for thiosulphate solution employed.

▼B**7. Expression of results**

1 ml of standard sodium thiosulphate solution (4.5) corresponds to 2 mg Cu.

The percentage of copper in the fertiliser is given by:

$$\text{Cu (\%)} = X \frac{V}{a \times M \times 5}$$

where

X is the volume in ml of the sodium thiosulphate solution used;

V is the volume in ml of the extract solution in accordance with Methods 10.1 and 10.2;

a is the volume in ml of the aliquot portion;

M is the mass in g of the test sample treated in accordance with Methods 10.1 and 10.2.

Method 10.8**Determination of iron in fertiliser extracts by atomic absorption spectrometry****1. Scope**

This Method describes a procedure for determining iron in fertiliser extracts.

2. Field of application

This procedure is applicable to extracts from samples of fertilisers obtained by Methods 10.1 and 10.2 for which a declaration of total and/or water-soluble iron is required by Annex I E to this Regulation.

3. Principle

After suitable treatment and dilution of the extract, the iron content is determined by atomic absorption spectrometry.

4. Reagents**4.1. Hydrochloric acid solution, about 6 mol/l**

See Method 10.4 (4.1).

4.2. Hydrochloric acid solution, about 0,5 mol/l

See Method 10.4 (4.2).

4.3. Hydrogen peroxide solution (30 % H₂O₂, d₂₀ = 1,11 g/ml) free from micro-nutrients**4.4. Lanthanum salt solutions (10 g of La per litre)**

See Method 10.4 (4.3).

4.5. Iron calibration solution**4.5.1. Iron stock solution (1 000 µg/ml)**

In a 500 ml beaker, weigh to the nearest 0,1 mg, 1 g of pure iron wire, add 200 ml of 6 mol/l hydrochloric acid (4.1) and 15 ml of hydrogen peroxide solution (4.3). Heat on a hotplate until the iron is completely dissolved. When cool, transfer quantitatively to a 1 000 ml volumetric flask. Make up to volume with water and mix thoroughly.

▼B

4.5.2. Iron working solution (100 µg/ml)

Place 20 ml of the stock solution (4.5.1) in a 200 ml volumetric flask. Make up to volume with the 0,5 mol/l hydrochloric acid solution (4.2) and mix thoroughly.

5. **Apparatus**

Atomic absorption spectrometer: see Method 10.4 (5). The instrument must be fitted with a source of emitted radiation characteristic of iron (248,3 nm).

6. **Preparation of the solution to be analysed**6.1. *Iron extract solution*

See Methods 10.1 and/or 10.2 and, if appropriate, 10.3.

6.2. *Preparation of the test solution*

See Method 10.4 (6.2). The test solution must contain 10 % (v/v) of a lanthanum salt solution.

7. **Procedure**7.1. *Preparation of blank solution*

See Method 10.4 (7.1). The blank solution must contain 10 % (v/v) of the lanthanum salt solution used in 6.2.

7.2. *Preparation of calibration solutions*

See Method 10.4 (7.2).

For an optimum determination range of 0 to 10 µg/ml of iron, place 0, 2, 4, 6, 8 and 10 ml respectively of working solution (4.5.2) in a series of 100 ml volumetric flasks. If necessary adjust the hydrochloric acid concentration as closely as possible to that of the test solution. Add 10 ml of the lanthanum salt solution used in 6.2. Make up to volume with 0,5 mol/l hydrochloric acid solution (4.2) and mix thoroughly. These solutions contain 0, 2, 4, 6, 8 and 10 µg/ml respectively of iron.

7.3. *Determination*

See Method 10.4 (7.3). Prepare the spectrometer (5) for measurement at a wavelength of 248,3 nm.

8. **Expression of results**

See Method 10.4 (8).

The percentage of iron in the fertiliser is given by:

$$\text{Fe (\%)} = [(x_s - x_b) \times V \times D]/(M \times 10^4)$$

If Method 10.3 is used:

$$\text{Fe (\%)} = [(x_s - x_b) \times V \times 2D]/(M \times 10^4)$$

Where

Fe is the quantity of iron expressed as a percentage of the fertiliser;

x_s is the concentration in µg/ml of the test solution (6.2);

x_b is the concentration in µg/ml of the blank solution (7.1);

V is the volume in ml of extract obtained in accordance with Method 10.1 or 10.2;

D is the factor of dilution carried out in 6.2;

▼B

M is the mass in grams of the test sample taken in accordance with Method 10.1 or 10.2.

Calculation of the dilution factor D: if (a_1) , (a_2) , (a_3) , ..., (a_i) and (a) are aliquot portions and (v_1) , (v_2) , (v_3) , ..., (v_i) and (100) are the volumes in ml corresponding to their respective dilutions, the dilution factor D is given by:

$$D = (v_1/a_1) \times (v_2/a_2) \times (v_3/a_3) \times \dots \times (v_i/a_i) \times (100/a)$$

Method 10.9

Determination of manganese in fertiliser extracts by titration**1. Scope**

This Method describes a procedure for determining manganese in fertiliser extracts.

2. Field of application

This procedure is applicable to extracts from samples of fertilisers obtained by Methods 10.1 and 10.2 for which a declaration of manganese is required by Annex I E to this.

3. Principle

If chloride ions are present in the extract, they are driven off by boiling the extract with sulphuric acid. The manganese is oxidised by sodium bismuthate in a nitric acid medium. The permanganate formed is reduced by an excess of ferrous sulphate. This excess is titrated with a potassium permanganate solution.

4. Reagents

4.1. Concentrated sulphuric acid (H_2SO_4 , $d_{20} = 1,84$ g/ml)

4.2. *Sulphuric acid, about 9 mol/l*

Carefully mix 1 volume of concentrated sulphuric acid (4.1) with 1 volume of water.

4.3. *Nitric acid, 6 mol/l*

Mix 3 volumes of nitric acid (HNO_3 , $d_{20} = 1,40$ g/ml) with 4 volumes of water.

4.4. *Nitric acid, 0,3 mol/l*

Mix 1 volume of 6 mol/l nitric acid with 19 volumes of water.

4.5. Sodium bismuthate ($NaBiO_3$) (85 %).

4.6. Kieselguhr

4.7. Orthophosphoric acid, 15 mol/l (H_3PO_4 , $d_{20} = 1,71$ g/ml)

4.8. *Ferrous sulphate solution, 0,15 mol/l*

Dissolve 41,6 g of ferrous sulphate heptahydrate ($FeSO_4 \cdot 7H_2O$) in a 1 litre volumetric flask.

Add 25 ml of concentrated sulphuric acid (4.1) and 25 ml phosphoric acid (4.7). Make up to 1 000 ml. Mix.

4.9. *Potassium permanganate solution, 0,020 mol/l*

Weigh out 3,160 g of potassium permanganate ($KMnO_4$) to within 0,1 mg. Dissolve and make up to 1 000 ml with water.

4.10. *Silver nitrate solution, 0,1 mol/l*

Dissolve 1,7 g of silver nitrate ($AgNO_3$) in water and make up to 100 ml.

▼B**5. Apparatus**

- 5.1. Filter crucible P16/ISO 4 793, porosity 4, capacity 50 ml, mounted on a 500 ml filtration flask.
- 5.2. Magnetic stirrer

6. Preparation of the solution to be analysed**6.1. Manganese extract solution**

See Methods 10.1 and 10.2. If it is not known whether chloride ions are present, perform a test on the solution with one drop of the silver nitrate solution (4.10).

- 6.2. In the absence of chloride ions, place an aliquot of the extract containing 10 to 20 mg of manganese in a tall form 400 ml beaker. Bring to a volume of about 25 ml either by evaporation or by adding water. Add 2 ml of concentrated sulphuric acid (4.1)

6.3. If chloride ions are present, it is necessary to remove them as follows

Place an aliquot of the extract containing 10 to 20 mg of manganese in a tall form 400 ml beaker. Add 5 ml of 9 mol/l sulphuric acid (4.2). Under a fume hood, bring to boiling on a hotplate and allow to boil until copious white fumes are released. Continue until the volume is reduced to about 2 ml (thin film of syrupy liquid at the bottom of the beaker). Allow to cool to ambient temperature.

Carefully add 25 ml of water and once again test for the presence of chlorides with one drop of the silver nitrate solution (4.10). If chlorides still remain, repeat the operation after adding 5 ml of 9 mol/l sulphuric acid (4.2).

7. Procedure

Add 25 ml of 6 mol/l nitric acid (4.3) and 2,5 g of sodium bismuthate (4.5) to the 400 ml beaker containing the test solution. Stir vigorously for three minutes on the magnetic stirrer (5.2).

Add 50 ml of 0,3 mol/l nitric acid (4.4) and stir again. Filter in vacuo through a crucible (5.1), the bottom of which is covered with Kieselguhr (4.6). Wash the crucible several times with the 0,3 mol/l nitric acid (4.4) until a colourless filtrate is obtained.

Transfer the filtrate and the washing solution into a 500 ml beaker. Mix and add 25 ml of 0,15 mol/l ferrous sulphate solution (4.8). If the filtrate turns yellow after the addition of ferrous sulphate, add 3 ml of 15 mol/l orthophosphoric acid (4.7).

Using a burette, titrate the excess ferrous sulphate with 0,02 mol/l potassium permanganate solution (4.9) until the mixture turns pink, the colour remaining stable for one minute. Perform a blank test under the same conditions, omitting only the test sample.

Note

The oxidised solution must not come into contact with rubber.

8. Expression of results

1 ml of 0,02 mol/l potassium permanganate solution corresponds to 1,099 mg of manganese (Mn).

▼B

The percentage of manganese in the fertiliser is given by:

$$\text{Mn (\%)} \text{ where } = (x_b - x_s) \times 0,1099 \times \frac{V}{a \times M}$$

Where

x_b is the volume in ml of the permanganate used for the blank;

x_s is the volume in ml of the permanganate used for the test sample;

V is the volume in ml of the extract solution in accordance with Methods 10.1 and 10.2;

a is the volume in ml of the aliquot portion taken from the extract;

M is the mass in g of the test sample.

Method 10.10

Determination of molybdenum in fertiliser extracts by the gravimetric method with 8-Hydroxyquinoline

1. Scope

This document describes a procedure for determining molybdenum in fertiliser extracts.

2. Field of application

This procedure is applicable to extracts from samples of fertilisers obtained by Methods 10.1 and 10.2 for which a declaration of molybdenum is required by Annex I E to this Regulation.

3. Principle

The molybdenum level is determined by precipitation as molybdenyl oxinate under specific conditions.

4. Reagents

4.1. Sulphuric acid solution, approximately 1 mol/l

Carefully pour 55 ml of sulphuric acid (H_2SO_4 , $d_{20} = 1,84$ g/ml) into a 1 litre volumetric flask containing 800 ml of water. Mix. After cooling, make up to one litre. Mix.

4.2. Diluted ammonia solution (1: 3)

Mix 1 volume of concentrated ammonia solution (NH_4OH , $d_{20} = 0,9$ g/ml) with 3 volumes of water.

4.3. Diluted acetic acid solution (1: 3)

Mix 1 volume of concentrated acetic acid (99,7 % CH_3COOH , $d_{20} = 1,049$ g/ml) with 3 volumes of water.

4.4. Solution of disodium salt of ethylene diamine tetraacetic acid (EDTA)

Dissolve 5 g of Na_2EDTA in water in a 100 ml volumetric flask. Make up to the calibration mark and mix.

4.5. Buffer solution

In a 100 ml volumetric flask, dissolve 15 ml of concentrated acetic acid and 30 g of ammonium acetate in water. Make up to 100 ml.

▼B4.6. *7-Hydroxyquinoline (oxine) solution*

In a 100 ml volumetric flask, dissolve 3 g of 8-Hydroxyquinoline in 5 ml of concentrated acetic acid. Add 80 ml of water. Add the ammonia solution (4.2) drop by drop until the solution becomes cloudy and then add the acetic acid (4.3) until the solution becomes clear again.

Make up to 100 ml with water.

5. **Apparatus**

5.1. Filter crucible P16/ISO 4 793, porosity 4, capacity 30 ml

5.2. pH meter with glass electrode

5.3. Drying oven at 130 to 135 °C

6. **Preparation of the solution to be analysed**

6.1. Preparation of the molybdenum solution. See Method 10.1 and Method 10.2

7. **Procedure**7.1. *Preparation of the test solution*

Place an aliquot portion containing 25 to 100 mg Mo in a 250 ml beaker. Make up the volume to 50 ml with water.

Adjust this solution to pH of 5 by adding the sulfuric acid solution (4.1) drop by drop. Add 15 ml of EDTA solution (4.4) and then 5 ml of buffer solution (4.5). Make up to about 80 ml with water.

7.2. *Obtaining and washing the precipitate*

Obtaining the precipitate

Heat the solution slightly. Stirring constantly, add the oxine solution (4.6). Continue the precipitation until formation of a deposit is no longer observed. Add further reagent until the supernatant solution turns slightly yellow. A quantity of 20 ml should normally be sufficient. Continue to heat the precipitate slightly for two or three minutes.

Filtration and washing

Filter through a filter crucible (5.1). Rinse several times with 20 ml of hot water. The rinse water should gradually become colourless indicating that oxine is not longer present.

7.3. *Weighing the precipitate*

Dry the precipitate at 130 to 135 °C to constant mass (at least one hour).

Allow to cool in a desiccator and then weigh.

8. **Expression of the results**

1 mg of molybdenyl oxinate, $\text{MoO}_2(\text{C}_9\text{H}_6\text{ON})_2$, corresponds to 0,2305 mg Mo.

The percentage of molybdenum in the fertiliser is given by:

$$\text{Mo (\%)} = X \times 0,02305 \times \frac{V \times D}{a \times M}$$

Where

X is the mass in mg of the molybdenyl oxinate precipitate;

V is the volume in ml of the extract solution in accordance with Methods 10.1 or 10.2;

a is the volume in ml of the aliquot taken from the last dilution;

▼B

D is the dilution factor of the aliquot;

M is the mass in g of the test sample.

Method 10.11**Determination of zinc in fertiliser extracts by atomic absorption spectrometry****1. Scope**

This Method describes a procedure for determining zinc in fertiliser extracts.

2. Field of application

This procedure is applicable to extracts from samples of fertilisers obtained by Methods 10.1 and 10.2 for which a declaration of zinc is required by Annex I E to this Regulation.

3. Principle

After suitable treatment and dilution of the extracts, the zinc level is determined by atomic absorption spectrometry.

4. Reagents**4.1. Hydrochloric acid solution, about 6 mol/l**

See Method 10.4 (4.1).

4.2. Hydrochloric acid solution, about 0,5 mol/l

See Method 10.4 (4.2).

4.3. Lanthanum salt solutions (10 g of La per litre)

See Method 10.4 (4.3).

4.4. Zinc calibration solutions**4.4.1. Zinc stock solution (1 000 µg/ml)**

In a 1 000 ml volumetric flask, dissolve 1 g of zinc powder or flakes weighed to within 0,1 mg in 25 ml of 6 mol/l hydrochloric acid (4.1). When completely dissolved, make up to volume with water and mix thoroughly.

4.4.2. Zinc working solution (100 µg/ml)

In a 200 ml volumetric flask, dilute 20 ml of the stock solution (4.4.1) in 0,5 mol/l hydrochloric acid solution (4.2). Make up to a volume with the 0,5 mol/l hydrochloric acid solution and mix thoroughly.

5. Apparatus

Atomic absorption spectrometer.

See Method 10.4 (5). The apparatus must be fitted with a source of lines characteristic of zinc (213,8 nm). The spectrometer must allow background correction to be made.

6. Preparation of the solution to be analysed**6.1. Zinc extract solution**

See Method 10.1 and/or 10.2.

6.2. Preparation of the test solution

See Method 10.4 (6.2). The test solution must contain 10 % by volume of lanthanum salt solution (4.3).

▼B**7. Procedure****7.1. Preparation of the blank solution**

See Method 10.4 (7.1). The blank solution must contain 10 % by volume of the lanthanum salt solution used in 6.2.

7.2. Preparation of the calibration solutions

See Method 10.4 (7.2). For an optimum interval of 0 to 5 µg/ml of zinc, place 0, 0,5, 1, 2, 3, 4 and 5 ml, respectively, of the working solution (4.4.2) in a series of 100 ml volumetric flasks. Where necessary, adjust the concentration of hydrochloric acid to bring it as close as possible to that of the test solution. Add 10 ml of the lanthanum salt solution used in (6.2) to each volumetric flask. Make up to 100 ml with the 0,5 mol/l hydrochloric acid solution (4.2) and mix thoroughly.

These solutions contain, respectively, 0, 0,5, 1, 2, 3, 4 and 5 µg/ml of zinc.

7.3. Determination

See Method 10.4 (7.3). Prepare the spectrometer (5) for measurements at a wavelength of 213,8 nm.

8. Expression of results

See Method 10.4 (8).

The percentage of zinc in the fertiliser is given by:

$$\text{Zn (\%)} = [(x_s - x_b) \times V \times D] / (M \times 10^4)$$

If Method 10.3 has been used:

$$\text{Zn (\%)} = [(x_s - x_b) \times V \times 2D] / (M \times 10^4)$$

Where

Zn is the quantity of zinc expressed as a percentage of the fertiliser;

x_s is the concentration in µg/ml of the test solution;

x_b is the concentration in µg/ml of the blank solution;

V is the volume in ml of the extract solution obtained in accordance with Method 10.1 or 10.2;

D is the factor corresponding to the dilution performed in (6.2);

M is the mass in g of the test sample taken in accordance with Method 10.1 or 10.2.

Calculation of the dilution factor D:

where (a1), (a2), (a3), ..., (ai) and (a) are successive aliquot portions and (v1), (v2), (v3), ..., (vi) and (100) are the volumes in ml corresponding to their respective dilutions, the dilution factor D is given by:

$$D = (v1/a1) \times (v2/a2) \times (v3/a3) \times \dots \times (vi/ai) \times (100/a)$$

▼ **M7**

Methods 11

Chelating agents

Method 11.1

Determination of the chelated micro-nutrient content and of the chelated fraction of micro-nutrients

EN 13366: Fertilisers — Treatment with a cation exchange resin for the determination of the chelated micro-nutrient content and of the chelated fraction of micro-nutrients

This method of analysis has been ring-tested.

Method 11.2

Determination of EDTA, HEDTA and DTPA

EN 13368-1: Fertilisers — Determination of chelating agents in fertilisers by ion chromatography — Part 1: EDTA, HEDTA and DTPA

This method of analysis has been ring-tested.

▼ **M9**

Method 11.3

Determination of iron chelated by o,o-EDDHA, o,o-EDDHMA and HBED

EN 13368-2: Fertilizers – Determination of chelating agents in fertilizers by chromatography. Part 2: Determination of Fe chelated by o,o-EDDHA, o,o-EDDHMA and HBED by ion pair-chromatography

This method of analysis has been ring-tested.

▼ **M7**

Method 11.4

Determination of iron chelated by EDDHSA

EN 15451: Fertilisers — Determination of chelating agents-Determination of iron chelated by EDDHSA by ion pair-chromatography

This method of analysis has been ring-tested.

Method 11.5

Determination of iron chelated by o,p EDDHA

EN 15452: Fertilisers — Determination of chelating agents-Determination of iron chelated by o,p EDDHA by reversed phase HPLC

This method of analysis has been ring-tested.

▼ **M9**

Method 11.6

Determination of IDHA

EN 15950: Fertilizers – Determination of N-(1,2-dicarboxyethyl)-D,L-aspartic acid (Iminodisuccinic acid, IDHA) using high-performance liquid chromatography (HPLC)

This method of analysis has been ring-tested.

Method 11.7

Determination of lignosulfonates

EN 16109: Fertilizers – Determination of micro-nutrient ions complexed in fertilizers – Identification of lignosulfonates

This method of analysis has been ring-tested.

▼ M9

Method 11.8

Determination of the complexed micro-nutrient content and of the complexed fraction of micro-nutrients

EN 15962: Fertilizers – Determination of the complexed micro-nutrient content and of the complexed fraction of micro-nutrients

This method of analysis has been ring-tested.

▼ M7

Methods 12

Nitrification and urease inhibitors

Method 12.1

Determination of dicyandiamide

EN 15360: Fertilisers — Determination of dicyandiamide – Method using high-performance liquid chromatography (HPLC)

This method of analysis has been ring-tested.

Method 12.2

Determination of NBPT

EN 15688: Fertilisers — Determination of urease inhibitor N-(n-butyl)thiophosphoric triamide (NBPT) using high-performance liquid chromatography (HPLC)

This method of analysis has been ring-tested.

▼ M9

Method 12.3

Determination of 3-methylpyrazole

EN 15905: Fertilizers – Determination of 3-methylpyrazole (MP) using high-performance liquid chromatography (HPLC)

This method of analysis has been ring-tested.

Method 12.4

Determination of TZ

EN 16024: Fertilizers – Determination of 1H,1,2,4-triazole in urea and in fertilizers containing urea – Method using high-performance liquid chromatography (HPLC)

This method of analysis has been ring-tested.

Method 12.5

Determination of 2-NPT

EN 16075: Fertilizers – Determination of N-(2-nitrophenyl)phosphoric triamide (2-NPT) in urea and fertilizers containing urea – Method using high-performance liquid chromatography (HPLC)

This method of analysis has been ring-tested.

▼ M7

Methods 13

Heavy metals

Method 13.1

Determination of cadmium content

EN 14888: Fertilisers and liming materials — Determination of cadmium content

This method of analysis has been ring-tested.

▼B

ANNEX V

A. LIST OF DOCUMENTS TO BE CONSULTED BY MANUFACTURERS OR THEIR REPRESENTATIVES IN ORDER TO COMPILE A TECHNICAL FILE FOR A NEW TYPE OF FERTILISERS TO BE ADDED TO ANNEX I OF THIS REGULATION

1. Guide to the compilation of a technical file on application to designate fertilisers 'EC fertiliser'.

Official Journal of the European Communities, C 138 of 20.5.1994, p. 4.

2. Commission Directive 91/155/EEC of 5 March 1991 on defining and laying down the detailed arrangements for the system of specific information relating to dangerous preparations in implementation of Article 10 of Directive 88/379/EEC.

Official Journal of the European Communities, L 76/35 of 22.3.1991, p. 35.

3. Commission Directive 93/112/EC of 10 December 1993 on amending Commission Directive 91/155/EEC defining and laying down detailed arrangements for the system of specific information relating to dangerous preparations in implementation of Article 10 of Council Directive 88/379/EEC.

Official Journal of the European Communities, L 314 of 16.12.1993, p. 38.

▼M7**B. REQUIREMENTS TO AUTHORISE LABORATORIES THAT ARE COMPETENT TO PROVIDE THE NECESSARY SERVICE FOR CHECKING COMPLIANCE OF EC FERTILISERS WITH THE REQUIREMENTS OF THIS REGULATION AND ITS ANNEXES**

1. Standard applicable at the level of the laboratories.
 - Laboratories accredited in accordance with EN ISO/IEC 17025, General requirements for the competence of testing and calibration laboratories, for at least one of the methods of Annexes III or IV.
 - Until 18 November 2014, laboratories not yet accredited provided that the laboratory:
 - demonstrates that it has initiated and is pursuing the necessary accreditation procedures in accordance with EN ISO/IEC 17025 in one or more of the methods of Annexes III or IV, and
 - provides the competent authority with evidence that the laboratory is participating in inter-laboratory tests with good results.

2. Standard applicable at the level of accreditation bodies:

EN ISO/IEC 17011, Conformity assessment: General requirements for accreditation bodies accrediting conformity assessment bodies.