

I

(Acts adopted under the EC Treaty/Euratom Treaty whose publication is obligatory)

REGULATIONS

COMMISSION REGULATION (EC) No 631/2009

of 22 July 2009

laying down detailed rules for the implementation of Annex I to Regulation (EC) No 78/2009 of the European Parliament and of the Council on the type-approval of motor vehicles with regard to the protection of pedestrians and other vulnerable road users, amending Directive 2007/46/EC and repealing Directives 2003/102/EC and 2005/66/EC

THE COMMISSION OF THE EUROPEAN COMMUNITIES,

Having regard to the Treaty establishing the European Community,

Having regard to Regulation (EC) No 78/2009 of the European Parliament and of the Council of 14 January 2009 on the type-approval of motor vehicles with regard to the protection of pedestrians and other vulnerable road users, amending Directive 2007/46/EC and repealing Directives 2003/102/EC and 2005/66/EC ⁽¹⁾, and in particular Article 4(6) thereof,

Whereas:

- (1) Regulation (EC) No 78/2009 is one of the separate regulatory acts under the type-approval procedure laid down by Directive 2007/46/EC of the European Parliament and of the Council of 5 September 2007 on establishing a framework for the approval of motor vehicles and their trailers, and of systems, components and separate technical units intended for such vehicles ('Framework Directive') ⁽²⁾.
- (2) Regulation (EC) No 78/2009 sets out the basic requirements for the protection of pedestrians and other vulnerable road users in the form of tests and limit values for the type-approval of vehicles and of frontal protection systems as separate technical units.
- (3) The tests set out in Regulation (EC) No 78/2009 are based on the requirements set out in Directive 2003/102/EC of the European Parliament and of the Council of 17 November 2003 relating to the protection of pedestrians and

other vulnerable road users before and in the event of a collision with a motor vehicle and amending Council Directive 70/156/EEC ⁽³⁾ and Directive 2005/66/EC of the European Parliament and of the Council of 26 October 2005 relating to the use of frontal protection systems on motor vehicles and amending Council Directive 70/156/EEC ⁽⁴⁾.

- (4) A study completed regarding the specifications of certain requirements set out in Directive 2003/102/EC ⁽⁵⁾ indicated a need to provide amendments.
- (5) The technical prescriptions necessary to implement the requirements of Regulation (EC) No 78/2009 should be based on the specifications used in Commission Decision 2004/90/EC of 23 December 2003 on the technical prescriptions for the implementation of Article 3 of Directive 2003/102/EC of the European Parliament and of the Council relating to the protection of pedestrians and other vulnerable road users before and in the event of a collision with a motor vehicle and amending Directive 70/156/EEC ⁽⁶⁾ and Commission Decision 2006/368/EC of 20 March 2006 on the detailed technical requirements for carrying out the tests specified in Directive 2005/66/EC of the European Parliament and of the Council relating to the use of frontal protection systems on motor vehicles ⁽⁷⁾.

⁽¹⁾ OJ L 35, 4.2.2009, p. 1.

⁽²⁾ OJ L 263, 9.10.2007, p. 1.

⁽³⁾ OJ L 321, 6.12.2003, p. 15.

⁽⁴⁾ OJ L 309, 25.11.2005, p. 37.

⁽⁵⁾ A Study on the feasibility of measures relating to the protection of pedestrians and other vulnerable road users — Final 2006, Transport Research Laboratory, UK.

⁽⁶⁾ OJ L 31, 4.2.2004, p. 21.

⁽⁷⁾ OJ L 140, 29.5.2006, p. 33.

- (6) The measures provided for in this Regulation are in accordance with the opinion of the Technical Committee — Motor Vehicles.

HAS ADOPTED THIS REGULATION:

Article 1

This Regulation lays down the technical prescriptions necessary to carry out the tests and requirements specified in Annex I to Regulation (EC) No 78/2009.

Article 2

The tests set out in Annex I to Regulation (EC) No 78/2009 shall be carried out in accordance with the Annex to this Regulation.

This Regulation shall be binding in its entirety and directly applicable in all Member States.

Done at Brussels, 22 July 2009.

Article 3

Where, in the case of the tests for type-approval of a vehicle with regard of it being fitted with a frontal protection system or for a type-approval of such systems as a separate technical unit, the frontal protection system to be tested has been designed for use on more than one vehicle type, that system shall be type-approved separately for every vehicle type for which it is intended.

However, the technical service shall have the discretion to waive additional tests where the intended vehicle types or the frontal protection system types are considered to be sufficiently similar.

Article 4

This Regulation shall enter into force on the twentieth day following that of its publication in the *Official Journal of the European Union*.

For the Commission
Günter VERHEUGEN
Vice-President

ANNEX

PART I:	GENERAL REQUIREMENTS AND DEFINITIONS
PART II:	VEHICLE TEST SPECIFICATIONS
Chapter I:	General conditions
Chapter II:	Lower legform to bumper test
Chapter III:	Upper legform to bumper test
Chapter IV:	Upper legform to bonnet leading edge test
Chapter V:	Child/Small Adult headform to bonnet top test
Chapter VI:	Adult headform to windscreen test
Chapter VII:	Child/Small Adult and Adult headforms to bonnet top tests
PART III:	BRAKE ASSIST SYSTEMS SPECIFICATION
Appendix I:	Method for Determination of F_{ABS} and a_{ABS}
Appendix II:	Data Processing for BAS
PART IV:	FRONTAL PROTECTION SYSTEMS TEST SPECIFICATIONS
Chapter I:	General conditions
Chapter II:	Lower legform to Frontal Protection System test
Chapter III:	Upper legform to Frontal Protection System test
Chapter IV:	Upper legform to Frontal Protection System Leading Edge test
Chapter V:	Child/Small Adult headform to Frontal Protection System test
PART V:	TEST IMPACTORS
Appendix I:	Certification of Impactors

PART I

GENERAL REQUIREMENTS AND DEFINITIONS**1. General**

When performing measurements on a vehicle as described in this Part, the vehicle shall be positioned in its normal ride attitude.

If the vehicle is fitted with a badge, mascot or other structure which would bend back or retract under an applied load of maximum 100 N, then such a load shall be applied before and/or while these measurements are taken.

Any vehicle component which could change shape or position, other than suspension components or active devices to protect pedestrians, shall be set to their stowed position.

2. Definitions

For the purposes of this Annex the following definitions shall apply:

- 2.1. 'Bonnet leading edge height' for any section of a vehicle means the vertical distance between the ground and the bonnet leading edge reference line at that point;

- 2.2. 'Bonnet Leading Edge Reference Line' means the geometric trace of the points of contact between a straight edge 1 000 mm long and the front surface of the bonnet, when the straight edge, held parallel to the vertical longitudinal plane of the car and inclined rearwards by 50° from the vertical and with the lower end 600 mm above the ground, is traversed across and in contact with the bonnet leading edge (see Figure 16).

For vehicles having the bonnet top surface inclined at 50°, so that the straight edge makes a continuous contact or multiple contacts rather than a point contact, determine the reference line with the straight edge inclined rearwards at an angle of 40° from the vertical.

For vehicles of such shape that the bottom end of the straight edge makes first contact with the vehicle then that contact is taken to be the bonnet leading edge reference line, at that lateral position.

For vehicles of such shape that the top end of the straight edge makes first contact with the vehicle then the geometric trace of 1 000 mm wrap around distance, will be used as bonnet leading edge reference line at that lateral position.

The top edge of the bumper shall also be regarded as the bonnet leading edge if it is contacted by the straight edge during this procedure;

- 2.3. 'Bonnet rear reference line' means the geometric trace of the most rearward points of contact between a 165 mm sphere and the frontal upper surface, when the sphere is traversed across the frontal upper surface, while maintaining contact with the windscreen (see Figure 1). The wiper blades and arms are removed during this process;

If the bonnet rear reference line is located at a wrap around distance of more than 2 100 mm, the bonnet rear reference line is defined by the geometric trace of the 2 100 mm wrap around distance. Where the bonnet rear reference line and side reference lines do not intersect, the bonnet rear reference line shall be modified according to the procedure set out in point 2.17;

- 2.4. 'Bumper lead' for any longitudinal section of a vehicle means the horizontal distance measured in any vehicle vertical longitudinal plane between the upper bumper reference line and the bonnet leading edge reference line;

- 2.5. 'Centre of the knee' means the point about which the knee effectively bends;

- 2.6. 'Corner of bumper' means the vehicle's point of contact with a vertical plane which makes an angle of 60° with the vertical longitudinal plane of the vehicle and is tangential to the outer surface of the bumper (see Figure 2);

- 2.7. 'Corner of frontal protection system' means the frontal protection system's point of contact with a vertical plane, which makes an angle of 60° with the vertical longitudinal plane of the vehicle and is tangential to the outer surface of the frontal protection system (see Figure 3);

- 2.8. 'Corner of frontal protection system leading edge' means the frontal protection system's point of contact with a vertical plane which makes an angle of 45° with the vertical longitudinal plane of the vehicle and is tangential to the outer surface of the frontal protection system. The bottom edge of the plane shall be at a height of 600 mm, or 200 mm below the highest part of the frontal protection system, whichever is the higher;

- 2.9. 'Corner reference point' means the intersection of the bonnet leading edge reference line and of the side reference line (see Figure 4);

- 2.10. 'Essential outer front end dimensions' means solid points in space on the test frame, representing all points of the actual intended vehicle type where the frontal protection system would be liable to impact on the vehicle during testing;

- 2.11. 'Femur' means all components or parts of components (including flesh, skin covering, damper, instrumentation and brackets, pulleys, etc. attached to the impactor for the purpose of launching it) above the level of the centre of the knee;

- 2.12. 'Frontal protection system lead' for any point on a frontal protection system means the horizontal distance between the upper frontal protection system reference line and the position of the point being considered on the frontal protection system. This distance shall be measured, at any point, on a vertical plane parallel to the vertical longitudinal plane of the vehicle;

- 2.13. 'Frontal protection system leading edge' means the uppermost outer structure of the frontal protection system and excludes the vehicle bonnet and wings, the upper and side members of the headlight surround and any other attachments such as grills protecting only lights;
- 2.14. 'Frontal protection system leading edge height' for any vertical longitudinal section of the frontal protection system means the vertical distance between the ground reference level and the frontal protection system leading edge reference line at that section, with the vehicle positioned in its normal ride attitude;
- 2.15. 'Frontal protection system leading edge reference line' means the geometric trace of the points of contact between a straight edge 1 000 mm long and the front surface of the frontal protection system, when the straight edge, held parallel to the vertical longitudinal plane of the vehicle and inclined rearwards by 50° and with the lower end 600 mm above the ground, is traversed across and in contact with the frontal protection system leading edge. For frontal protection systems having a top surface inclined at essentially 50°, so that the straight edge makes a continuous contact or multiple contacts rather than a point contact, the reference line is determined with the straight edge inclined rearwards at an angle of 40°. For frontal protection systems of such shape that the bottom end of the straight edge makes first contact, then that contact is taken to be the frontal protection system leading edge reference line, at that lateral position. For frontal protection systems of such shape that the top end of the straight edge makes first contact, then the geometric trace of 1 000 mm wrap around distance will be used as the frontal protection system leading edge reference line at that lateral position. The top edge of the frontal protection system shall also be regarded as the frontal protection system leading edge for the purposes of this Regulation, if it is touched by the straight edge during this procedure (see Figure 5);
- 2.16. 'Impact point' means the point on the vehicle where initial contact by the test impactor occurs. The proximity of this point to the target point is dependent upon both the angle of travel by the test impactor and the contour of the vehicle surface (see point B in Figure 6);
- 2.17. 'Intersection of bonnet rear reference line and side reference line'. Where the bonnet rear reference line and side reference line do not intersect, the bonnet rear reference line is extended and/or modified using a semi-circular template, of radius 100 mm. The template shall be made of a thin flexible sheet material that easily bends to a single curvature in any direction. The template shall, if possible, resist double or complex curvature where this could result in wrinkling. The recommended material is a foam backed thin plastic sheet to allow the template to 'grip' the surface of the vehicle.

The template shall be marked up with four points 'A' through 'D', as shown in Figure 7, while the template is on a flat surface. The template shall be placed on the vehicle with Corners 'A' and 'B' coincident with the side reference line. Ensuring these two corners remain coincident with the side reference line, the template shall be slid progressively rearwards until the arc of the template makes first contact with the bonnet rear reference line. Throughout the process, the template shall be curved to follow, as closely as possible, the outer contour of the vehicle's bonnet top, without wrinkling or folding of the template. If the contact between the template and bonnet rear reference line is tangential and the point of tangency lies outside the arc scribed by points 'C' and 'D', then the bonnet rear reference line is extended and/or modified to follow the circumferential arc of the template to meet the side reference line, as shown in Figure 8.

If the template cannot make simultaneous contact with the side reference line at points 'A' and 'B' and tangentially with the bonnet rear reference line, or the point at which the bonnet rear reference line and template touch lies within the arc scribed by points 'C' and 'D', then additional templates shall be used where the radii are increased progressively in increments of 20 mm, until all the above criteria are met.

Once defined, the modified bonnet rear reference line is assumed in all subsequent paragraphs and the original ends of the line are no longer used;

- 2.18. 'Lower bumper height' means, at any transverse position, the vertical distance between the ground and the lower bumper reference line, with the vehicle positioned in its normal ride attitude;
- 2.19. 'Lower bumper reference line' means a line which identifies the lower limit to significant points of pedestrian contact with the bumper. The line is the geometric trace of the lower most points of contact between a straight edge 700 mm long and the bumper, when the straight edge, held parallel to the vertical longitudinal plane of the vehicle and inclined forwards by 25°, is traversed across the front of the vehicle, while maintaining contact with the ground and with the surface of the bumper (see Figure 9);
- 2.20. 'Lower frontal protection system height' means, at any transverse position, the vertical distance between the ground and the lower frontal protection system reference line, with the vehicle positioned in its normal ride attitude;

- 2.21. 'Lower frontal protection system reference line' means a line which identifies the lower limit to significant points of pedestrian contact with the frontal protection system. The line is the geometric trace of the lowermost points of contact between a straight edge 700 mm long and the frontal protection system, when the straight edge, held parallel to the vertical longitudinal plane of the vehicle and inclined forwards by 25°, is traversed across the front of the vehicle, while maintaining contact with the ground and with the surface of the frontal protection system (see Figure 10);
- 2.22. 'Rear windscreen reference line' means as the geometric trace of the most forward points of contact between a sphere and the windscreen, when a sphere of diameter 165 mm is traversed across the windscreen top frame, including any trim, while maintaining contact with the windscreen (see Figure 11);
- 2.23. 'Side reference line' means the geometric trace of the highest points of contact between a straight edge 700 mm long and the side of a vehicle, when the straight edge, held parallel to a transverse vertical plane of the vehicle and inclined inwards by 45° is traversed down the side and maintains contact with the sides of the frontal upper surface (see Figure 12);
- 2.24. 'Target point' means the intersection of the projection of the headform longitudinal axis with the front surface of the vehicle (see point A in Figure 6);
- 2.25. 'Third of the bonnet leading edge' means the geometric trace between the corner reference points, measured with a flexible tape following the outer contour of the leading edge, divided in three equal parts;
- 2.26. 'Third of the bonnet top' means the geometric trace of the area between the side reference lines, measured with a flexible tape following the outer contour of the bonnet top on any transverse section, divided in three equal parts;
- 2.27. 'Third of the frontal protection system' means the geometric trace between the corners of the frontal protection system, measured with a flexible tape following the outer horizontal contour of the frontal protection system, divided into three equal parts;
- 2.28. 'Third of the frontal protection system leading edge' means the geometric trace between the corners of the frontal protection system upper leading edge measured with a flexible tape following the horizontal outer contour of the frontal protection system, divided into three equal parts;
- 2.29. 'Third of the bumper' means the geometric trace between the corners of the bumper, measured with a flexible tape following the outer contour of the bumper, divided into three equal parts;
- 2.30. 'Tibia' means all components or parts of components (including flesh, skin covering, instrumentation and brackets, pulleys, etc. attached to the impactor for the purpose of launching it) below the level of the centre of the knee. Note that the tibia, as defined, includes allowances for the mass etc. of the foot;
- 2.31. 'Upper bumper reference line' means a line which identifies the upper limit to significant points of pedestrian contact with the bumper.

For vehicles with an identifiable bumper structure it is defined as the geometric trace of the uppermost points of contact between a straight edge and the bumper, when the straight edge, held parallel to the vertical longitudinal plane of the vehicle and inclined rearwards by 20° to the vertical, is traversed across the front of the vehicle, while maintaining contact with the surface of the bumper (see Figure 13).

For vehicles with no identifiable bumper structure it is defined as the geometric trace of the uppermost points of contact between a straight edge 700 mm long and the bumper, when the straight edge, held parallel to the vertical longitudinal plane of the vehicle and inclined rearwards by 20° to the vertical, is traversed across the front of the vehicle, while maintaining contact with the ground and with the surface of the bumper (see Figure 13).

Where necessary the straight edge shall be shortened to avoid any contact with structures above the bumper;

- 2.32. 'Upper frontal protection system height' means, at any transverse position, the vertical distance between the ground and the upper frontal protection system reference line, with the vehicle positioned in its normal ride attitude;

- 2.33. 'Upper frontal protection system reference line' means a line which identifies the upper limit to significant points of pedestrian contact with the frontal protection system. The line is the geometric trace of the upper most points of contact between a straight edge 700 mm long and the frontal protection system, when the straight edge, held parallel to the vertical longitudinal plane of the vehicle and inclined rearwards by 20°, is traversed across the front of the vehicle, while maintaining contact with the ground and with the surface of the frontal protection system (see Figure 14).

Where necessary the straight edge shall be shortened to avoid any contact with structures above the frontal protection system;

- 2.34. 'Vehicle type' means a category of vehicles which, forward of the A-pillars, do not differ in any of the following aspects in so far as the changes may be considered to have a negative effect on the results of the impact tests set out in Regulation (EC) No 78/2009:

- (a) the structure;
- (b) the main dimensions;
- (c) the materials of the outer surfaces of the vehicle;
- (d) the component arrangement (external or internal);
- (e) the method of fixing a frontal protection system, where one is fitted.

For purposes of consideration of frontal protection systems to be approved as separate technical units, any reference to vehicle may be interpreted to refer to the frame on which the system is mounted for testing and which is intended to represent the front end outer dimensions of the particular vehicle for which the system is being approved;

- 2.35. 'Wrap Around Distance' means the geometric trace described on the frontal upper surface or the frontal protection system by one end of a flexible tape, when it is held in a vertical longitudinal plane of the vehicle and traversed across the frontal upper surface or frontal protection system. The tape is held taut throughout the operation with one end in contact with ground reference level, vertically below the front face of the bumper or frontal protection system and the other end is held in contact with the frontal upper surface or frontal protection system (see Figure 15, for example). The vehicle is positioned in the normal ride attitude.

This procedure shall be followed, using appropriate measuring tape lengths, to describe wrap around distances of 900 mm (WAD900), 1 000 mm (WAD1000), 1 700 mm (WAD1700) and 2 100 mm (WAD2100).

Figure 1

Determination of bonnet rear reference line

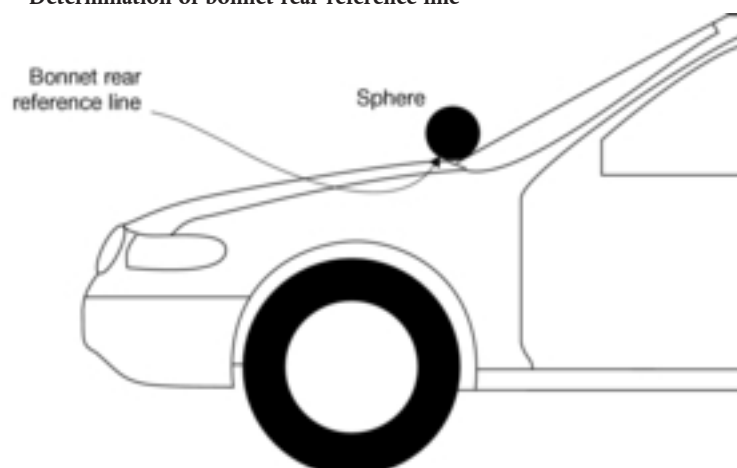

Figure 2
Determination of corner of bumper

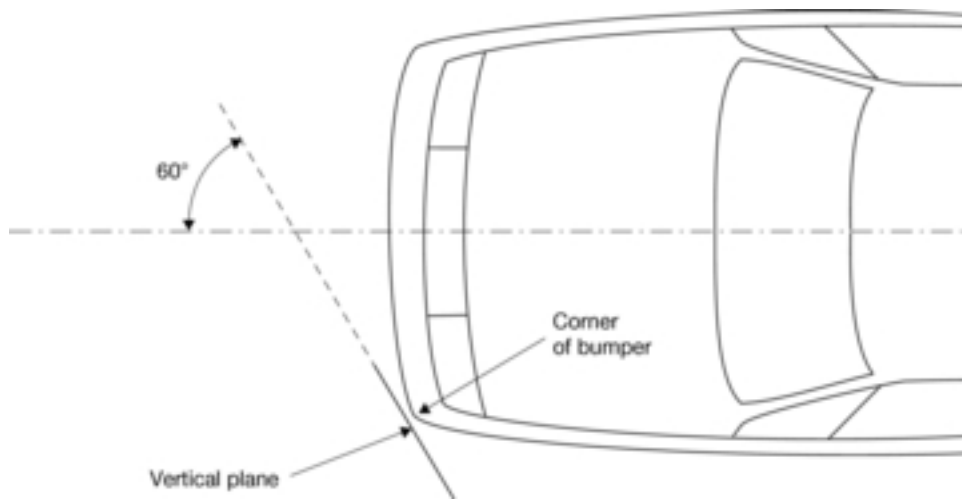

Figure 3
Determination of Corner of Frontal Protection System

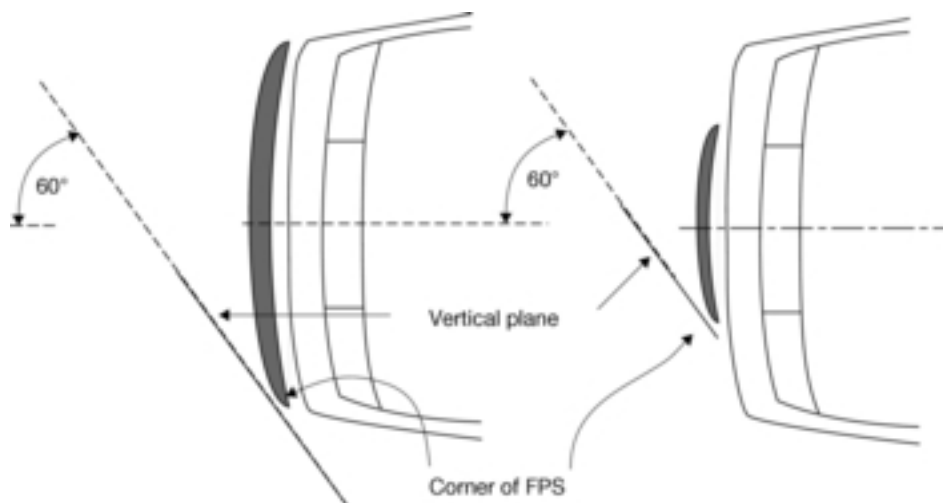

Figure 4

Determination of corner reference point; intersection of the bonnet leading edge reference line and the side reference line

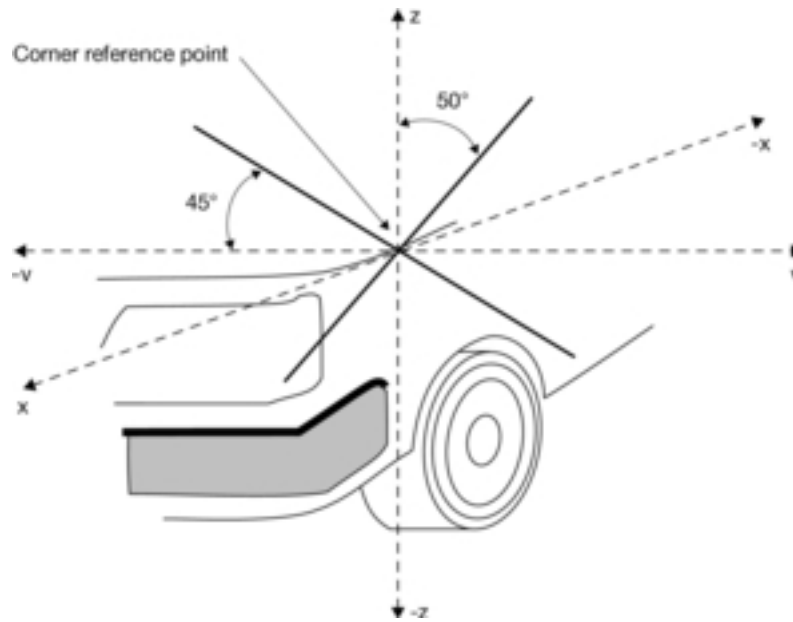

Figure 5

Determination of Frontal Protection System Leading Edge Reference Line

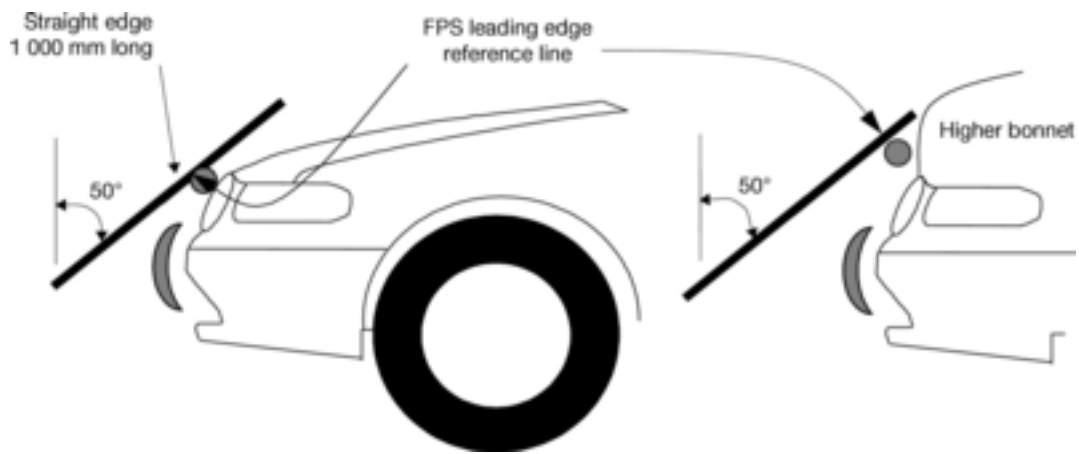

Figure 6

Impact and target points

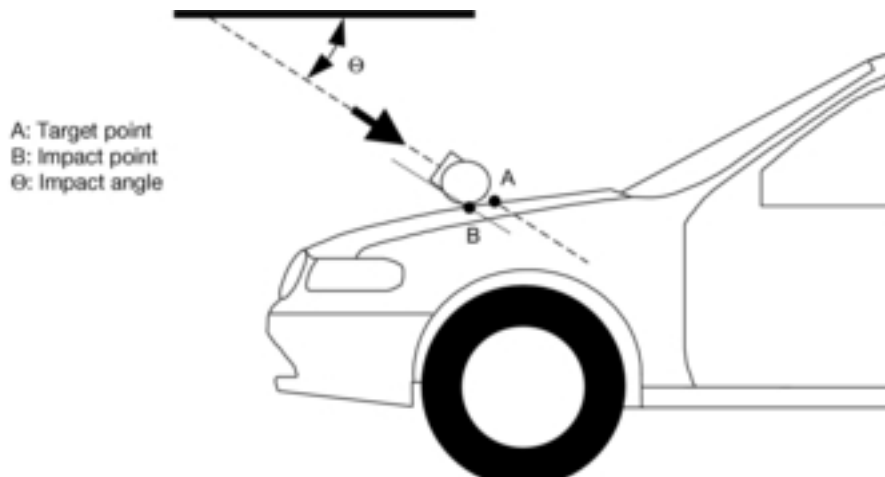

Figure 7

Template design and markings used to join bonnet rear reference line and side reference line

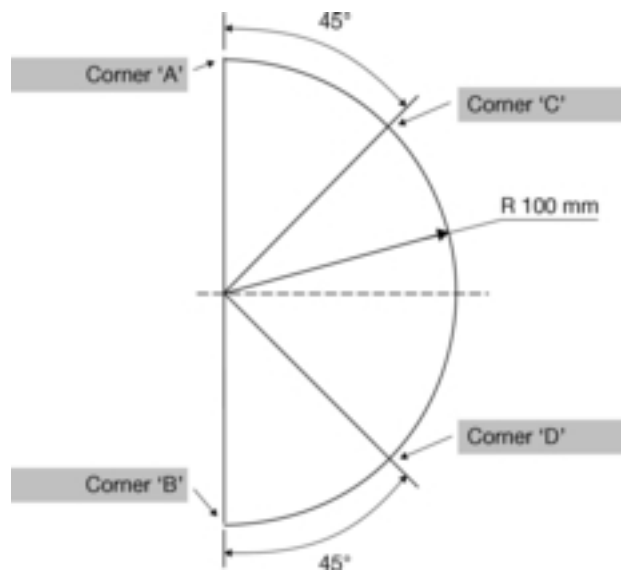

Figure 8

Plan view of rear corner of bonnet — extending the bonnet rear reference line to meet the side reference line along the circumferential arc of template

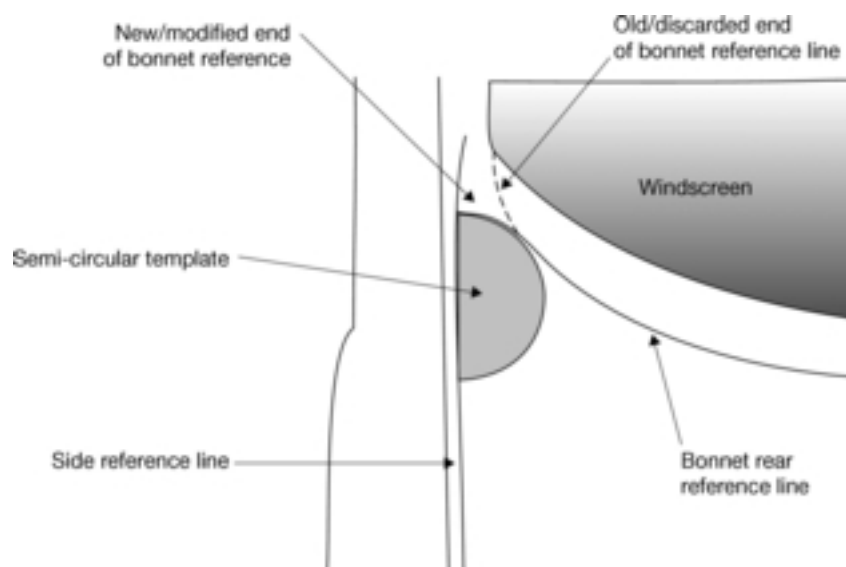

Figure 9
Determination of lower bumper reference line

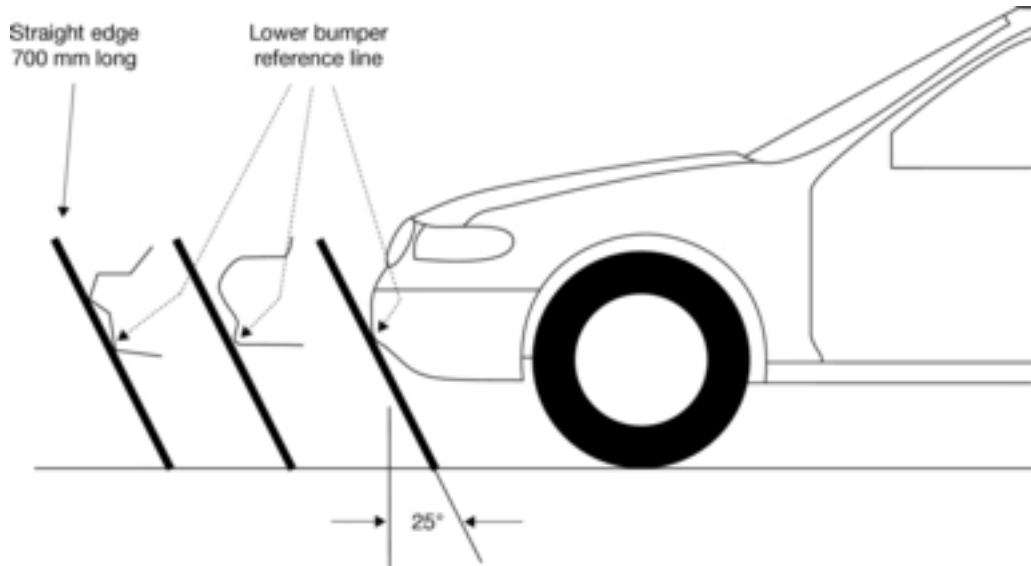

Figure 10
Determination of Lower Frontal Protection System Reference Line

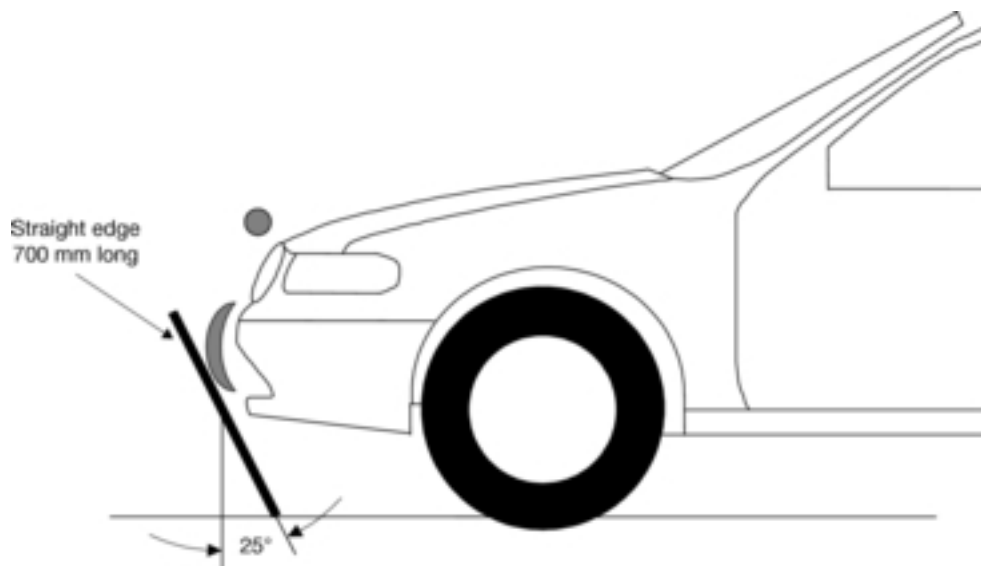

Figure 11

Determination of rear windscreen reference line

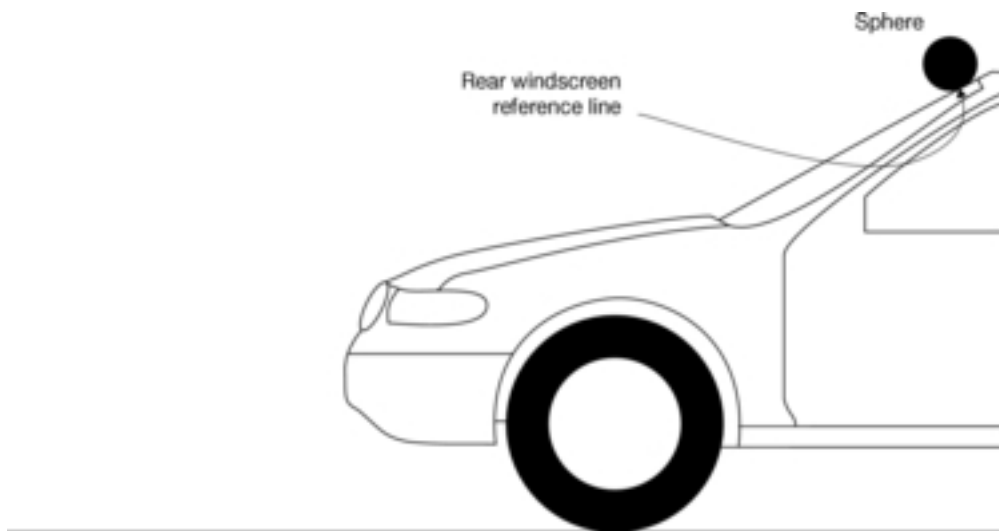

Figure 12

Determination of side reference line

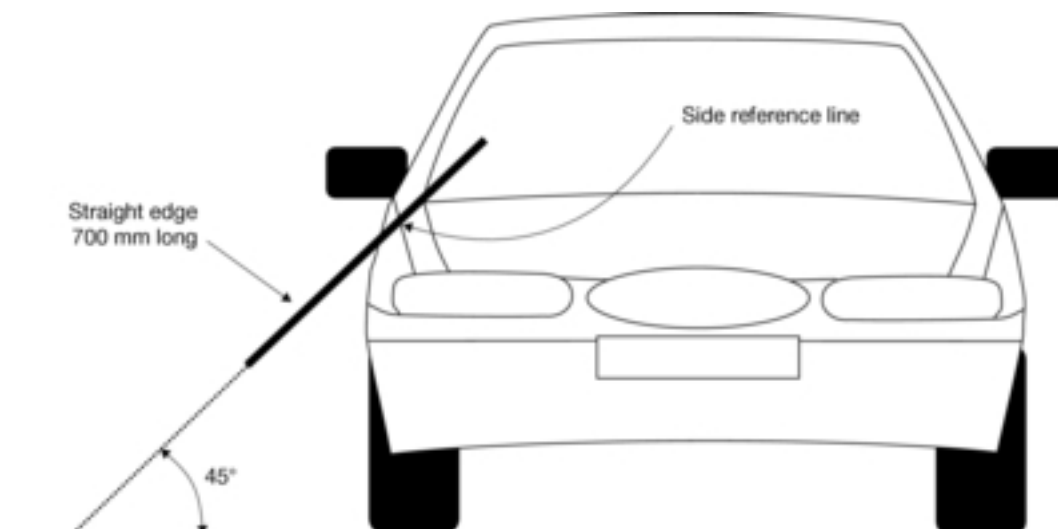

Figure 13

Determination of upper bumper reference line

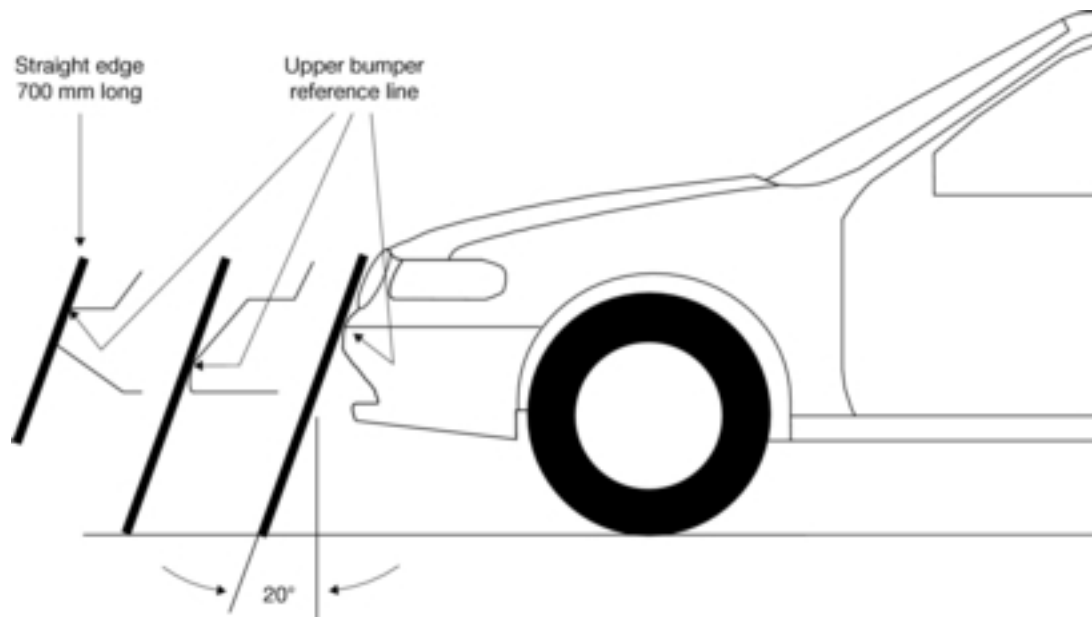

Figure 14

Determination of Upper Frontal Protection System Reference Line

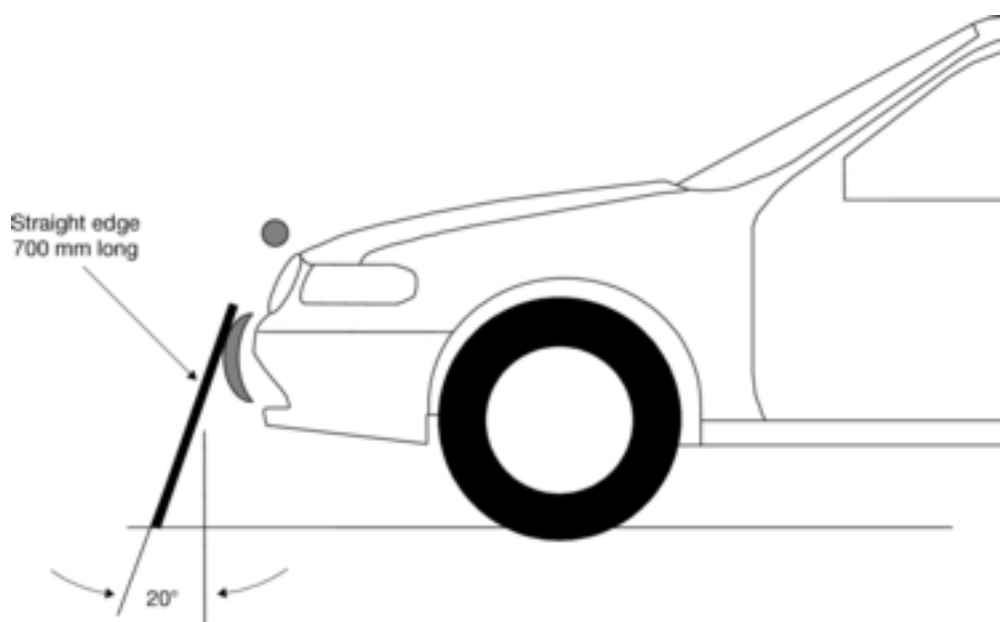

Figure 15

Determination of Frontal Protection System wrap around distance

Figure 16

Determination of bonnet leading edge reference line

PART II

VEHICLE TEST SPECIFICATIONS

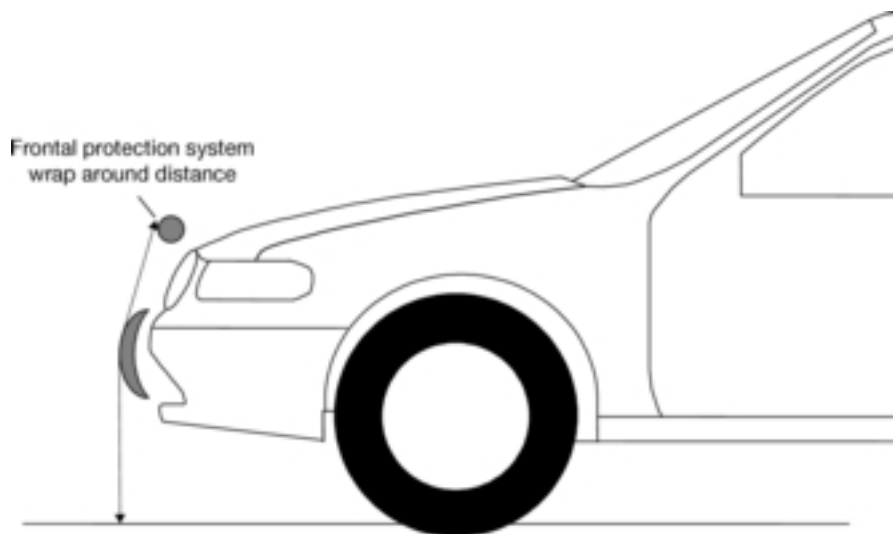
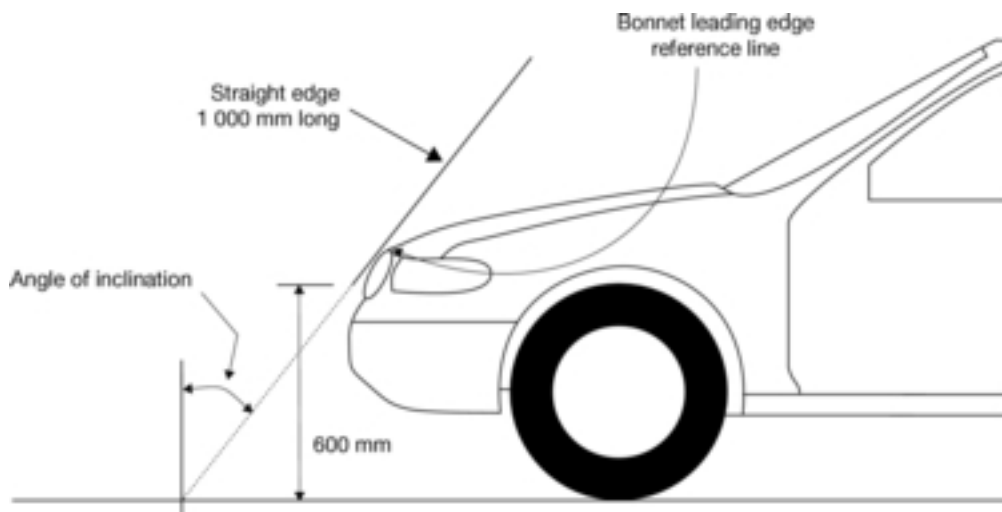
CHAPTER I

General conditions

1. Complete vehicle

- 1.1. For testing on complete vehicles, the vehicles shall comply with the conditions detailed in points 1.1.1, 1.1.2 and 1.1.3.
 - 1.1.1. The vehicle shall be in its normal ride attitude and shall be either securely mounted on raised supports or at rest on a flat surface with the hand brake on.
 - 1.1.2. All devices designed to protect vulnerable road users shall be correctly activated before and/or be active during the appropriate test. It shall be the responsibility of the applicant for approval to show that the devices will act as intended in a pedestrian impact.

- 1.1.3. Any vehicle component which could change shape or position, other than active devices to protect pedestrians, and which have more than one fixed shape or position shall require the vehicle to comply with the components in each fixed shape or position.

2. Subsystem of vehicle

- 2.1. Where only a subsystem of the vehicle is supplied for tests, it shall comply with the conditions detailed in points 2.1.1, 2.1.2, 2.1.3 and 2.1.4.
 - 2.1.1. All the parts of the vehicle structure, bonnet and under-bonnet components or behind windscreen components that may be involved in a frontal impact with a vulnerable road user shall be included in the test to demonstrate the performance and interactions of all the contributory vehicle components.
 - 2.1.2. The vehicle subsystem shall be securely mounted in the vehicle normal ride attitude.
 - 2.1.3. All devices designed to protect vulnerable road users shall be correctly activated before and/or be active during the appropriate test. It shall be the responsibility of the applicant for approval to show that the devices will act as intended in a pedestrian impact.
 - 2.1.4. Any vehicle component which could change shape or position, other than active devices to protect pedestrians, and which have more than one fixed shape or position shall require the vehicle to comply with the components in each fixed shape or position.

CHAPTER II

Lower legform to bumper test

1. Scope

This test procedure shall apply to the requirements set out in points 2.1(a) and 3.1(a) of Annex I to Regulation (EC) No 78/2009.

2. General

- 2.1. The lower legform impactor for the bumper tests shall be in 'free flight' at the moment of impact. The impactor shall be released to free flight at such a distance from the vehicle that the test results are not influenced by contact of the impactor with the propulsion system during rebound of the impactor.
- 2.2. The impactor may be propelled by an air, spring or hydraulic gun, or by other means that can be shown to give the same result.

3. Specification of the test

- 3.1. The purpose of the test is to ensure that the requirements set out in point 2.1.(a) and point 3.1(a) of Annex I to Regulation (EC) No 78/2009 are fulfilled.
- 3.2. This test shall apply to vehicles with a lower bumper height of less than 425 mm.

For vehicles with a lower bumper height which is equal to, or greater than, 425 mm and less than 500 mm the manufacturer may choose to apply the test set out in Chapter III.

For vehicles with a lower bumper height of equal to, or greater than, 500 mm Chapter III shall apply.

- 3.3. A minimum of three lower legform to bumper tests shall be carried out, one each to the middle and the outer thirds of the bumper at positions judged to be the most likely to cause injury. The tests shall be performed to different types of structure, where they vary throughout the area to be assessed. The selected test points shall be a minimum of 132 mm apart, and a minimum of 66 mm inside the defined corners of the bumper. These minimum distances are to be set with a flexible tape held tautly along the outer surface of the vehicle. The positions tested by the laboratories shall be indicated in the test report.

4. Test procedure

- 4.1. The state of the vehicle or subsystem shall comply with the requirements of Chapter I.
 - 4.1.1. The test impactor or at least the foam flesh shall be stored during a period of at least four hours in a controlled storage area with a stabilised humidity of 35 percent \pm 15 percent and a stabilised temperature of 20 \pm 4 °C prior to impactor removal for testing. After removal from the storage the impactor shall not be subjected to conditions other than those existing in the test area.

- 4.1.2. Each test shall be completed within two hours of when the impactor to be used is removed from the controlled storage area.
- 4.2. The lower legform impactor to be used for the purposes of this test shall be the one as described in Section 1 of Part V.
- 4.3. The impactor shall be mounted, propelled and released as set out in points 2.1 and 2.2.
- 4.4. The direction of the impact velocity vector shall be in the horizontal plane and parallel to the longitudinal vertical plane of the vehicle. The tolerance for the direction of the velocity vector in the horizontal plane and in the longitudinal plane shall be $\pm 2^\circ$ at the time of first contact.
- 4.5. The axis of the impactor shall be perpendicular to the horizontal plane with a tolerance of $\pm 2^\circ$ in the lateral and longitudinal plane. The horizontal, longitudinal and lateral planes are orthogonal to each other (see Figure 1).
- 4.6. The bottom of the impactor shall be 25 mm above the ground reference level at the time of first contact with the bumper (see Figure 2), with a ± 10 mm tolerance.

When setting the height of the propulsion system, an allowance shall be made for the influence of gravity during the period of free flight of the impactor.

At the time of first contact the impactor shall have the intended orientation about its vertical axis, for the correct operation of its knee joint, with a tolerance of $\pm 5^\circ$ (see Figure 1).

- 4.7. At the time of first contact the centre line of the impactor shall be within a ± 10 mm tolerance to the selected impact location.
- 4.8. During contact between the impactor and the vehicle, the impactor shall not contact the ground or any object which is not part of the vehicle.
- 4.9. The impact velocity of the impactor when striking the bumper shall be $11,1 \pm 0,2$ m/s. The effect of gravity shall be taken into account when the impact velocity is obtained from measurements taken before the time of first contact.

Figure 1

Tolerances of angles for the lower legform impactor at the time of first impact

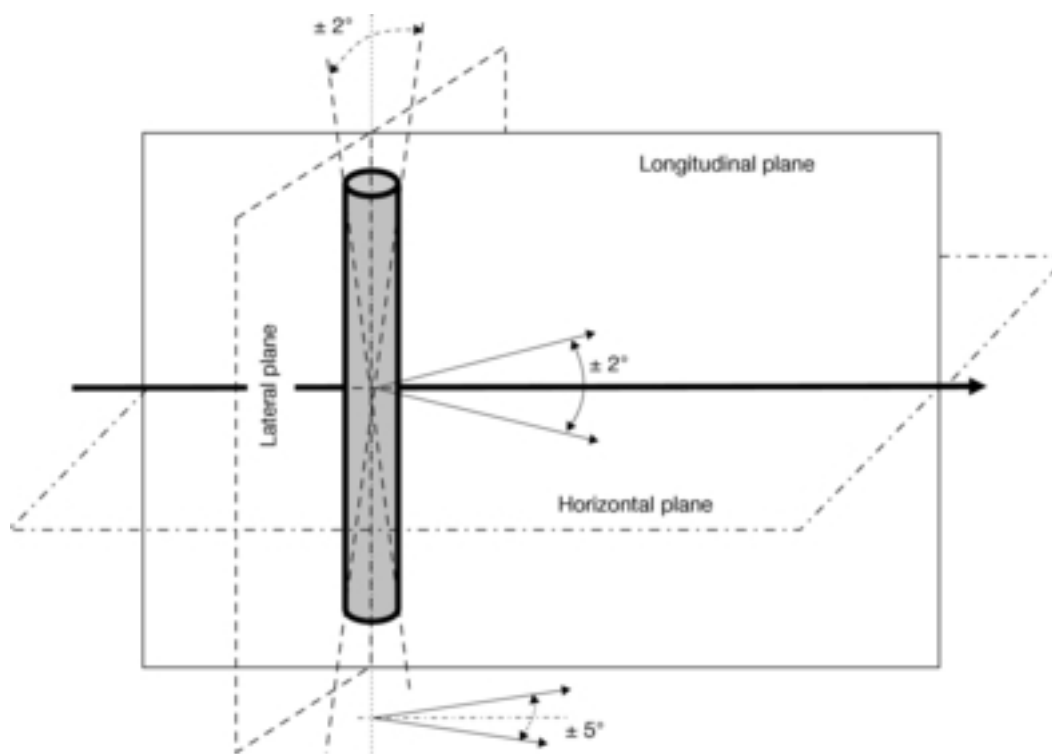
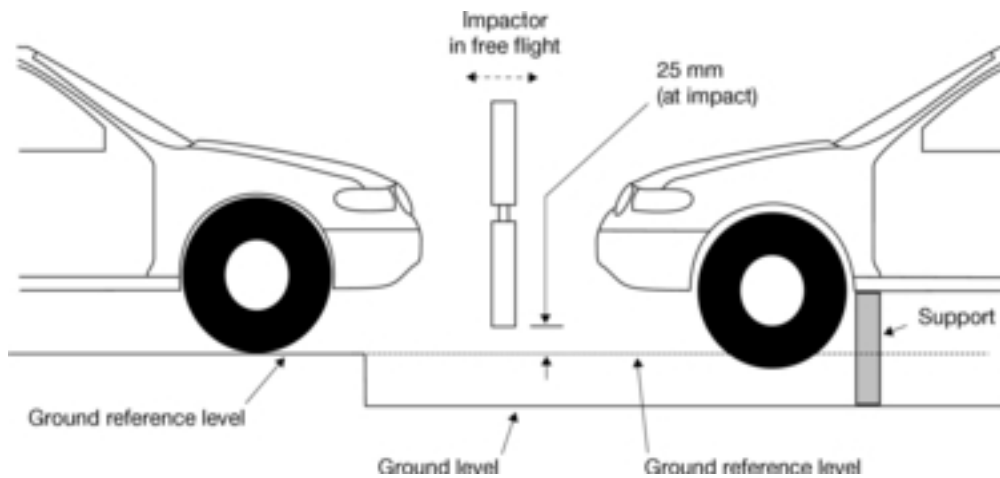

Figure 2

Lower legform to bumper tests for complete vehicle in normal ride attitude (left) and for complete vehicle or sub-system mounted on supports (right)



CHAPTER III

Upper legform to bumper test

1. Scope

This test procedure shall apply to the requirements set out in points 2.1(b) and 3.1(b) of Annex I to Regulation (EC) No 78/2009.

2. General

- 2.1. The upper legform impactor for the bumper test shall be mounted to the propulsion system, by a torque limiting joint, to prevent large off centre loads damaging the guidance system. The guidance system shall be fitted with low friction guides, insensitive to off-axis loading, that allow the impactor to move only in the specified direction of impact, when in contact with the vehicle. The guides shall prevent motion in other directions including rotation about any axis.
- 2.2. The impactor may be propelled by an air, spring or hydraulic gun, or by other means that can be shown to give the same result.

3. Specification of the test

- 3.1. The purpose of the test is to ensure that the requirements set out in point 2.1(b) and point 3.1(b) of Annex I to Regulation (EC) No 78/2009 are fulfilled.
- 3.2. The test shall apply to vehicles with a lower bumper height of equal to, or greater than, 500 mm.

For vehicles with a lower bumper height which is equal to, or greater than, 425 mm and less than 500 mm the manufacturer may choose to apply the test set out in Chapter II.

For vehicles with a lower bumper height less than 425 mm Chapter II shall apply.

- 3.3. Upper legform to bumper tests shall be carried out to test positions selected in point 3.3, Chapter II.

4. Test procedure

- 4.1. The state of the vehicle or sub-system shall comply with the requirements of Chapter I.
 - 4.1.1. The test impactor or at least the foam flesh shall be stored during a period of at least four hours in a controlled storage area with a stabilised humidity of 35 percent \pm 15 percent and a stabilised temperature of 20 \pm 4 °C prior to impactor removal for testing. After removal from the storage the impactor shall not be subjected to conditions other than those existing in the test area.

- 4.1.2. Each test shall be completed within two hours of when the impactor to be used is removed from the controlled storage area.
- 4.2. The upper legform impactor to be used for the purposes of this test shall be the one as described in Section 2 of Part V.
- 4.3. The impactor shall be mounted, propelled and released as defined in points 2.1 and 2.2.
- 4.4. The direction of impact shall be parallel to the longitudinal axis of the vehicle, with the axis of the upper legform vertical at the time of first contact. The tolerance to these directions is $\pm 2^\circ$. At the time of first contact the impactor centre line shall be vertically midway between the upper bumper reference line and the lower bumper reference line with a ± 10 mm tolerance and the impactor vertical centre line shall be positioned laterally with the selected impact location with a tolerance of ± 10 mm.
- 4.5. The impact velocity of the upper legform impactor when striking the bumper shall be $11,1 \pm 0,2$ m/s.

CHAPTER IV

Upper legform to bonnet leading edge test

1. Scope

This test procedure shall apply to the requirements set out in points 2.2 and 3.2 of Annex I to Regulation (EC) No 78/2009.

2. General

- 2.1. The upper legform impactor for the bonnet leading edge test shall be mounted to the propulsion system, by a torque limiting joint, to prevent large off centre loads damaging the guidance system. The guidance system shall be fitted with low friction guides, insensitive to off-axis loading, that allow the impactor to move only in the specified direction of impact, when in contact with the vehicle. The guides shall prevent motion in other directions including rotation about any axis.
- 2.2. The impactor may be propelled by an air, spring or hydraulic gun, or by other means that can be shown to give the same result.

3. Specification of the test

- 3.1. The purpose of the test is to ensure that the requirements set out in points 2.2 and 3.2 of Annex I to Regulation (EC) No 78/2009 are fulfilled.
- 3.2. A minimum of three upper legform to bonnet leading edge tests shall be carried out, one each to the middle and the outer thirds of the bonnet leading edge at positions judged to be the most likely to cause injury. However, the test point in each third shall be selected such that the required kinetic energy of impact, determined in point 4.8, exceeds 200 J, if such a point is available. The tests shall be performed to different types of structure, where they vary throughout the area to be assessed. The selected test points shall be a minimum of 150 mm apart, and a minimum of 75 mm inside the defined corner reference points. These minimum distances are to be set with a flexible tape held tautly along the outer surface of the vehicle. The positions tested by the laboratories shall be indicated in the test report.
- 3.3. All standard equipment fitted to the front end of the vehicle shall be in position.

4. Test procedure

- 4.1. The state of the vehicle or subsystem shall comply with the requirements of Chapter I.
 - 4.1.1. The test impactor or at least the foam flesh shall be stored during a period of at least four hours in a controlled storage area with a stabilised humidity of 35 percent \pm 15 percent and a stabilised temperature of 20 ± 4 °C prior to impactor removal for testing. After removal from the storage the impactor shall not be subjected to conditions other than those existing in the test area.
 - 4.1.2. Each test shall be completed within two hours of when the impactor to be used is removed from the controlled storage area.
 - 4.2. The upper legform impactor to be used for the purposes of this test shall be the one as described in Section 2 of Part V.
 - 4.3. The upper legform impactor shall be mounted and propelled as set out in points 2.1 and 2.2.

- 4.4. The upper legform impactor shall be aligned such that the centre line of the propulsion system and the longitudinal axis of the impactor are parallel to the longitudinal vertical plane of the vehicle to be tested. The tolerances to these directions are $\pm 2^\circ$. At the time of first contact the impactor centre line shall be coincident with the bonnet leading edge reference line with a ± 10 mm tolerance (see Figure 3), and laterally with the selected impact location with a tolerance of ± 10 mm.
- 4.5. The required impact velocity, the direction of impact and the upper legform impactor mass shall be determined as specified in points 4.7 and 4.8. The tolerance to the impact velocity is $\pm 2\%$ and the tolerance to the impact direction is $\pm 2^\circ$. The effect of gravity shall be taken into account when the impact velocity is obtained from measurements taken before the time of first contact. The upper legform impactor mass shall be measured to an accuracy of better than $\pm 1\%$, and if the measured value differs from the required value then the required velocity shall be adjusted to compensate, as specified in point 4.8.
- 4.6. Determination of vehicle shape:
- 4.6.1. The position of the upper bumper reference line shall be determined as defined in Part I.
- 4.6.2. The bonnet leading edge reference line shall be determined as defined in Part I.
- 4.6.3. For the section of bonnet leading edge to be tested the bonnet leading edge height and the bumper lead shall be determined as defined in Part I.
- 4.7. The required impact velocity and the direction of impact shall be determined from Figures 4 and 5 with reference to the values of bonnet leading edge height and bumper lead determined in point 4.6.3.
- 4.8. The total mass of the upper legform impactor includes those propulsion and guidance components which are effectively part of the impactor during the impact, including the extra weights.

Calculate the value of the upper legform impactor mass from:

$$M = 2E / V^2$$

Where:

M = Mass [kg]

E = Impact Energy [J]

V = Velocity [m/s].

The required velocity shall be the value derived under point 4.7 and the energy shall be derived from Figure 6 with reference to the values of bonnet leading edge height and bumper lead determined in point 4.6.3.

The upper legform impactor mass may be adjusted from the calculated value by up to $\pm 10\%$, provided the required impact velocity is also changed using the above formula to maintain the same impactor kinetic energy.

- 4.9. Fit the required extra weights to give the calculated value of upper legform impactor mass, determined in point 4.8, to the rear of the rear member of the impactor, or to components of the guidance system which are effectively part of the impactor during the impact.

Figure 3

Upper legform to bonnet leading edge tests

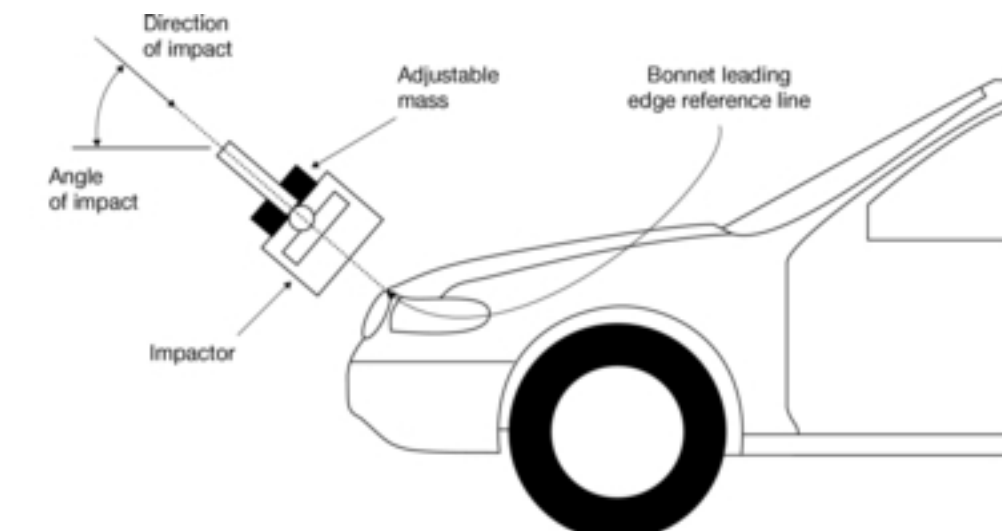
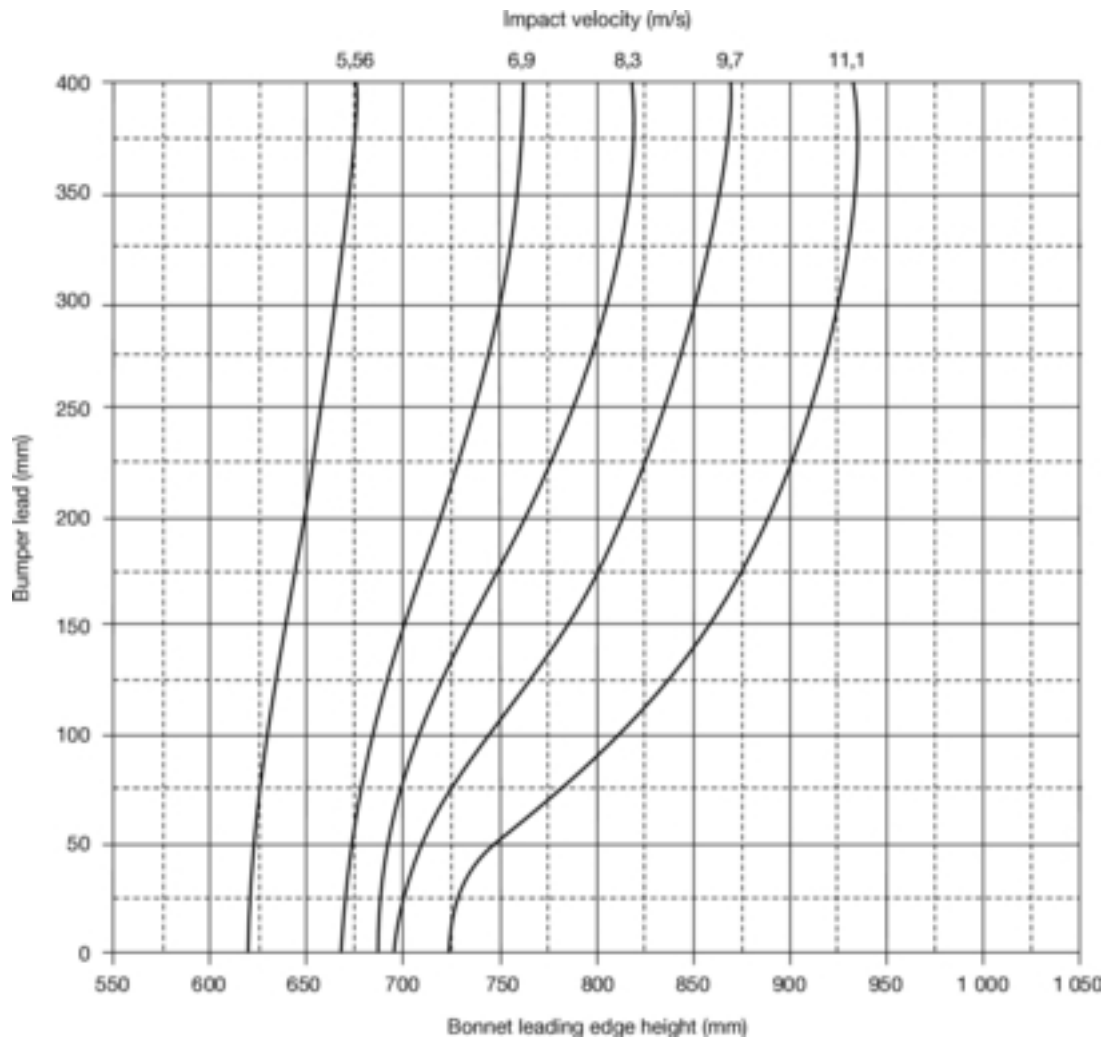

Figure 4

Velocity of upper legform to bonnet leading edge tests with respect to vehicle shape



Notes:

1. Interpolate horizontally between curves.
2. With configurations below 5,56 m/s — test at 5,56 m/s.
3. With configurations above 11,1 m/s — test at 11,1 m/s.
4. With negative bumper leads — test as for zero bumper lead.
5. With bumper leads above 400 mm — test as for 400 mm.

Figure 5

Angle of upper legform to bonnet leading edge tests with respect to vehicle shape

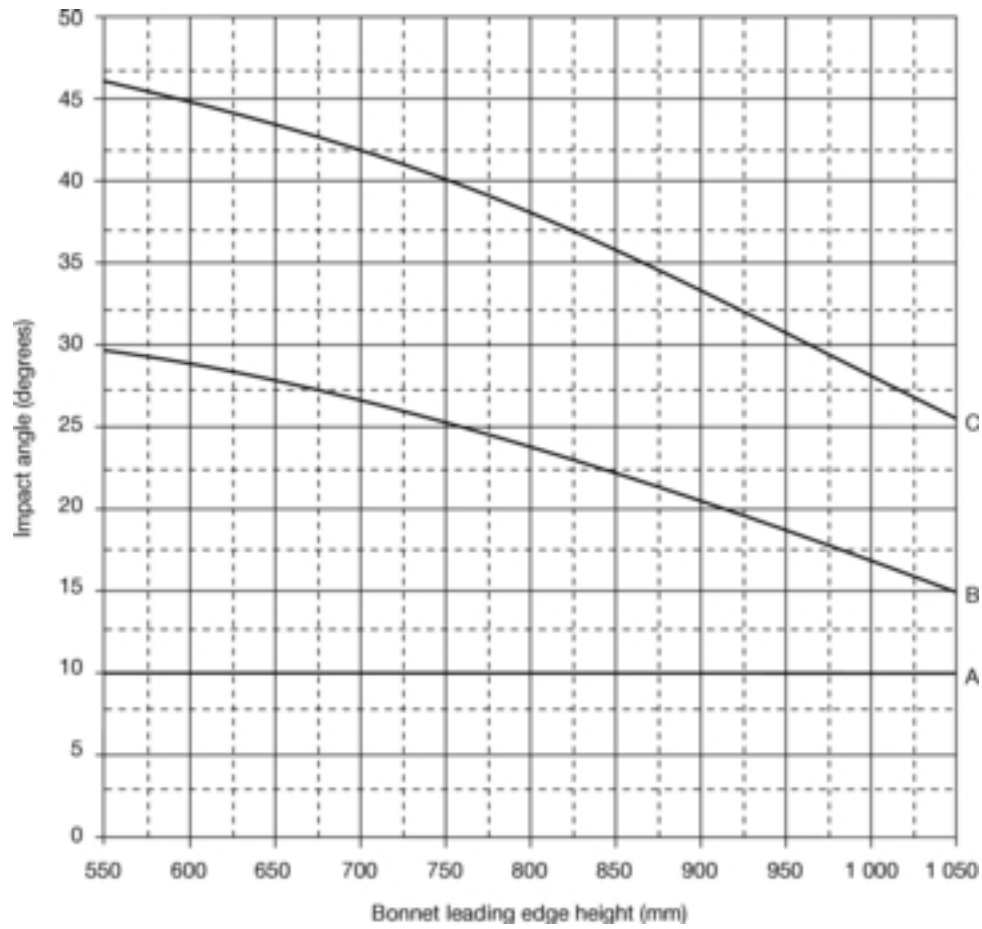

Key:

A = 0 mm bumper lead

B = 50 mm bumper lead

C = 150 mm bumper lead

Notes:

1. Interpolate vertically between curves.
2. With negative bumper leads
— test as for zero bumper lead.
3. With bumper leads above 150 mm
— test as for 150 mm.
4. With bonnet leading edge heights above 1 050 mm
— test as for 1 050 mm.

Figure 6

Kinetic energy of upper legform to bonnet leading edge tests with respect to vehicle shape

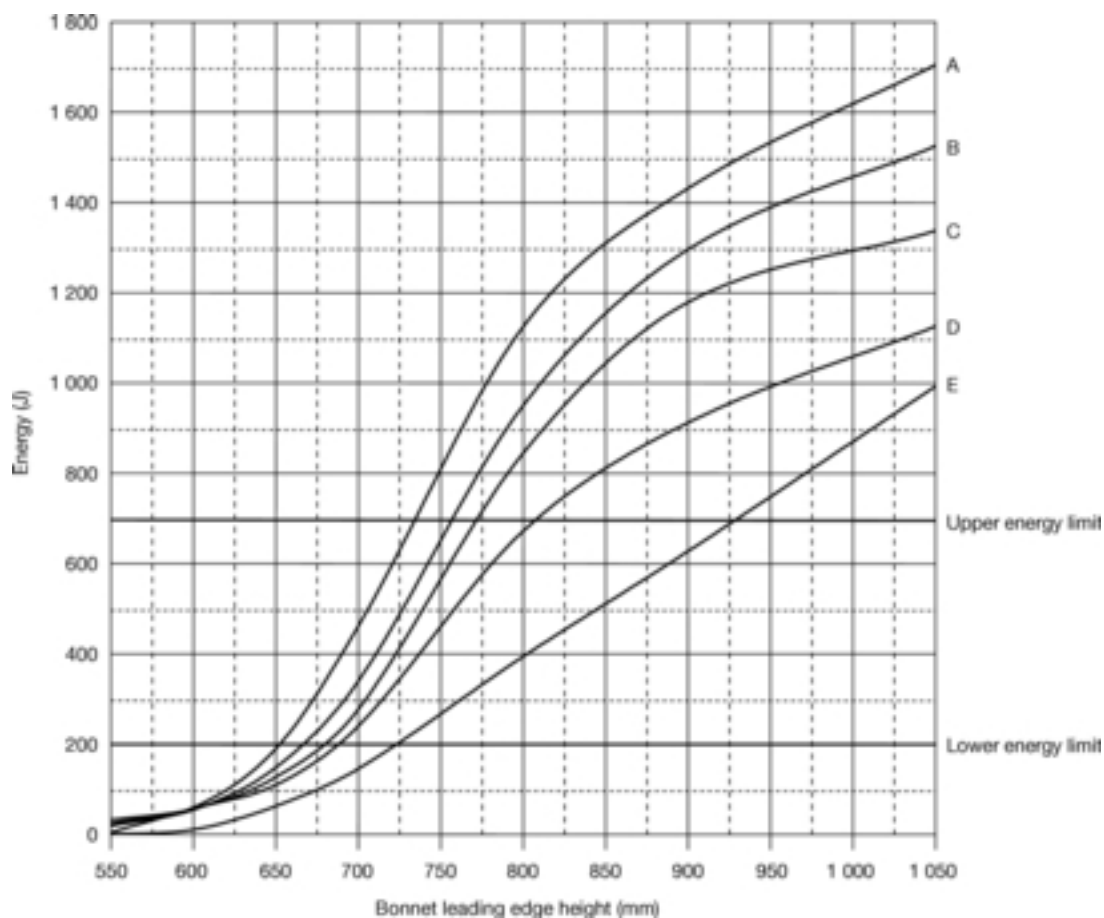

Key:

- A = 50 mm bumper lead
- B = 100 mm bumper lead
- C = 150 mm bumper lead
- D = 250 mm bumper lead
- E = 350 mm bumper lead

Notes

1. Interpolate vertically between curves.
2. With bumper leads below 50 mm — test as for 50 mm.
3. With bonnet leading edge heights above 1 050 mm — test as for 1 050 mm.
4. With a required kinetic energy above 700 J — test at 700 J.
5. With a required kinetic energy equal to or below 200 J — no test is required.
6. With bumper leads above 350 mm — test as for 350 mm.

CHAPTER V

Child/small adult headform to bonnet top test

1. Scope

This test procedure shall apply to the requirements set out in point 2.3 of Annex 1 to Regulation (EC) No 78/2009.

2. General

- 2.1. The headform impactor for the bonnet top test shall be in 'free flight' at the moment of impact. The impactor shall be released to free flight at such a distance from the vehicle that the test results are not influenced by contact of the impactor with the propulsion system during rebound of the impactor.
- 2.2. The impactor may be propelled by an air, spring or hydraulic gun, or by other means that can be shown to give the same result.

3. Specification of the test

- 3.1. The purpose of the test is to ensure that the requirements set out in point 2.3 of Annex I to Regulation (EC) No 78/2009 are fulfilled.
- 3.2. Headform impactor tests shall be to the bonnet top. A minimum of eighteen tests shall be carried out with the headform impactor, six tests each to the middle and the outer thirds of the bonnet top at positions judged to be the most likely to cause injury. Tests shall be to different types of structure, where these vary throughout the area to be assessed.

Among the minimum of eighteen tests, at least twelve tests shall be carried out with the headform impactor within the 'HPC1000 Zone' and a minimum of six tests shall be carried out within the 'HPC2000 Zone' as set out in point 3.2.1.

The test points shall be located so that the impactor is not expected to impact the bonnet top with a glancing blow and then impact the windscreen or an A-pillar more severely.

The selected test points for the child/small adult headform impactor shall be a minimum of 165 mm apart, a minimum of 82,5 mm inside the defined side reference lines, a minimum of 82,5 mm forwards of the defined bonnet rear reference line.

Each selected test point for the child/small adult headform shall also be a minimum of 165 mm rearwards of the bonnet leading edge reference line, unless no point in the bonnet leading edge test area within 165 mm laterally would, if chosen for an upper legform to bonnet leading edge test, require a kinetic energy of impact of more than 200 J.

These minimum distances are to be set with a flexible tape held tautly along the outer surface of the vehicle. If a number of test positions have been selected and the test area remaining is too small to select another test position while maintaining the minimum spacing between tests, then less than eighteen tests may be performed. The positions tested by the laboratories shall be indicated in the test report.

However, the technical services conducting the tests shall perform as many tests as necessary to guarantee the compliance of the vehicle with the head protection criteria (HPC) limit values of 1 000 for 'HPC1000 zone' and 2 000 for 'HPC2000 zone', especially in the points near to the borders between the two types of zones.

- 3.2.1. Identification of 'HPC1000 zone' and 'HPC2000 zone'. The manufacturer shall identify the zones of the bonnet top where the head protection criterion (HPC) shall not exceed 1 000 (HPC1000 zone) respectively 2 000 (HPC2000 zone), in accordance with the requirements set out in point 2.3 of Annex I to Regulation (EC) No 78/2009 (see Figure 7).

Figure 7

Marking of HPC1000 and HPC2000 zones

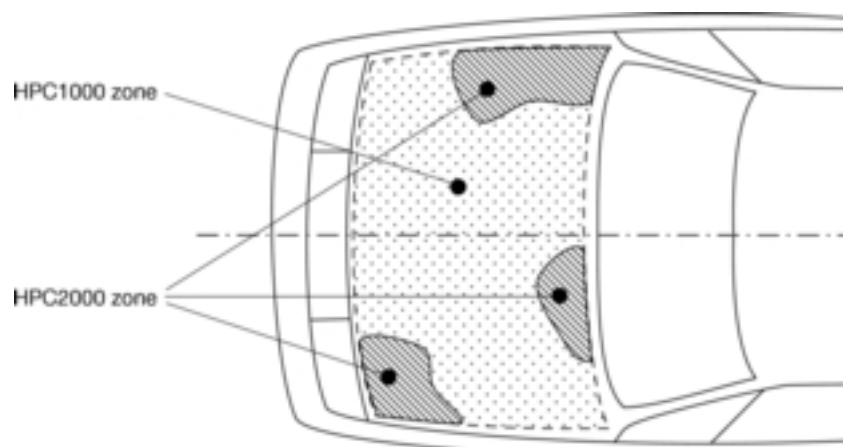

- 3.2.2. Marking of the bonnet top impact area as well as the 'HPC1000 zone' and 'HPC2000 zone' will be based on a drawing, supplied by the manufacturer, showing a view from a horizontal plane above the vehicle that is parallel to the vehicle horizontal zero plane. A sufficient number of x and y coordinates shall be supplied by the manufacturer to mark up the areas on the actual vehicle while considering the vehicle outer contour in the z direction.
- 3.2.3. The areas of 'HPC1000 zone' and 'HPC2000 zone' may consist of several parts, with the number of these parts not being limited.
- 3.2.4. The calculation of the surface of the impact area as well as the surface areas of 'HPC1000 zone' and 'HPC2000 zone' shall be done on the basis of a projected bonnet when viewed from a horizontal plane parallel to the horizontal zero plane above the vehicle, on the basis of the drawing data supplied by the manufacturer.
- 4. Test procedure**
- 4.1. The state of the vehicle or subsystem shall comply with the requirements of Chapter I. The stabilised temperature of the test apparatus and the vehicle or subsystem shall be $20\text{ °C} \pm 4\text{ °C}$.
- 4.2. The child/small adult headform impactor to be used for the purposes of this test shall be the one as described in Section 3 of Part V.
- 4.3. The impactor shall be mounted, propelled and released as defined in points 2.1 and 2.2.
- 4.4. For tests at the rear of the bonnet top the headform impactor shall not contact the windscreen or A-pillar before impacting the bonnet top.
- 4.5. The direction of impact shall be on a vertical longitudinal plane of the vehicle through the impact point. The tolerance for this direction is $\pm 2^\circ$. The direction of impact of tests to the bonnet top shall be downward and rearward, as if the vehicle were on the ground. The angle of impact for tests with the child/small adult headform impactor shall be $50^\circ \pm 2^\circ$ to the ground reference level. The effect of gravity shall be taken into account when the impact angle is obtained from measurements taken before the time of first contact.
- 4.6. At the time of first contact, the point of contact of the headform impactor shall be within a $\pm 10\text{ mm}$ of the selected impact location.
- 4.7. The impact velocity of the headform impactor when striking the bonnet top shall be $9,7 \pm 0,2\text{ m/s}$.
- 4.7.1. The velocity of the headform impactor shall be measured at some point during the free flight before impact, in accordance with the method specified in ISO 3784:1976. The accuracy of velocity measurement shall be $\pm 0,01\text{ m/s}$. The measured velocity shall be adjusted considering all factors which may affect the impactor between the point of measurement and the point of impact, in order to determine the velocity of the impactor at the time of impact.
- 4.8. The acceleration time histories shall be recorded, and HIC shall be calculated. The first point of contact on the front structure of the vehicle shall be recorded. Recording of test results shall be in accordance with ISO 6487:2002.

CHAPTER VI

Adult headform to windscreen test

1. Scope

This test procedure shall apply to the requirements set out in point 2.4 of Annex I to Regulation (EC) No 78/2009.

2. General

- 2.1. The headform impactor for the windscreen top test shall be in 'free flight' at the moment of impact. The impactor shall be released to free flight at such a distance from the vehicle that the test results are not influenced by contact of the impactor with the propulsion system during rebound of the impactor.
- 2.2. The impactor may be propelled by an air, spring or hydraulic gun, or by other means that can be shown to give the same result.

3. Specification of the test

- 3.1. The purpose of the test is to ensure that the requirements set out in point 2,4 of Annex I to Regulation (EC) No 78/2009 are fulfilled.
- 3.2. The adult headform impactor tests shall be to the windscreen. A minimum of five tests shall be carried out with the headform impactor at positions judged to be the most likely to cause injury.

The selected test points for the adult headform impactor to the windscreen shall be a minimum of 165 mm apart, a minimum of 82,5 mm inside the windscreen limits as defined in Directive 77/649/EEC and a minimum of 82,5 mm forwards of the rear windscreen reference line (see Figure 8).

These minimum distances are to be set with a flexible tape held tautly along the outer surface of the vehicle. If a number of test positions have been selected and the test area remaining is too small to select another test position while maintaining the minimum spacing between tests, then less than five tests may be performed. The positions tested by the laboratories shall be indicated in the test report.

4. Test procedure

- 4.1. The state of the vehicle or sub-system shall comply with the requirements of Chapter I. The stabilised temperature of the test apparatus and the vehicle or sub-system shall be $20\text{ }^{\circ}\text{C} \pm 4\text{ }^{\circ}\text{C}$.
- 4.2. The adult headform impactor to be used for the purposes of this test shall be the one as described in Section 4 of Part V.
- 4.3. The headform impactors shall be mounted, propelled and released as set out in points 2.1 and 2.2.
- 4.4. The direction of impact shall be on a vertical longitudinal plane of the vehicle through the impact point. The tolerance for this direction is $\pm 2^{\circ}$. The angle of impact shall be $35^{\circ} \pm 2^{\circ}$ downwards and rearwards to the Ground Reference Level. The effect of gravity shall be taken into account when the impact angle is obtained from measurements taken before the time of first contact.
- 4.5. At the time of first contact, the point of first contact of the headform impactor shall be within a $\pm 10\text{ mm}$ tolerance to the selected impact location.
- 4.6. The impact velocity of the headform impactor when striking the windscreen shall be $9,7 \pm 0,2\text{ m/s}$.
- 4.6.1. The velocity of the headform impactor shall be measured at some point during the free flight before impact, in accordance with the method specified in ISO 3784:1976. The accuracy of velocity measurement shall be $\pm 0,01\text{ m/s}$. The measured velocity shall be adjusted considering all factors which may affect the impactor between the point of measurement and the point of impact, in order to determine the velocity of the impactor at the time of impact.
- 4.7. The acceleration time histories shall be recorded, and HIC shall be calculated. The first point of contact on the front structure of the vehicle shall be recorded. Recording of test results shall be in accordance with ISO 6487:2002.

Figure 8

Windscreen impact area

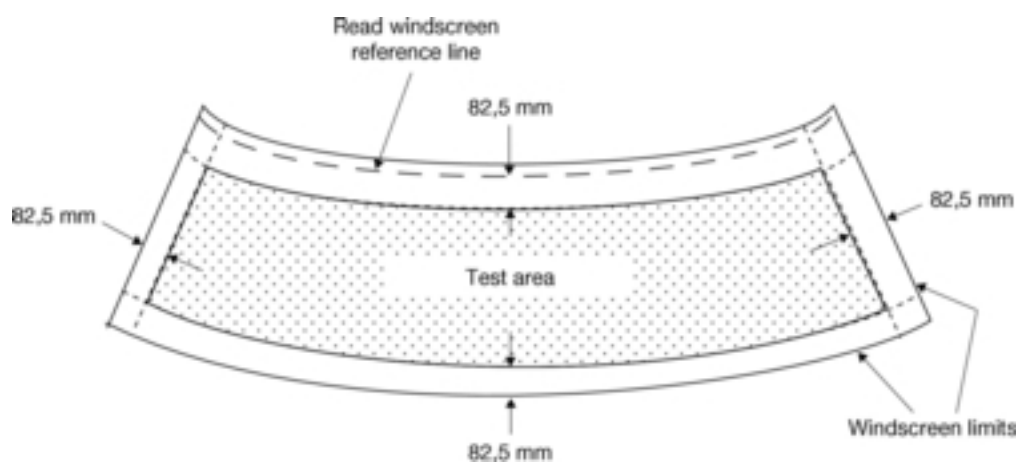

CHAPTER VII

Child/Small Adult and Adult headforms to bonnet top tests**1. Scope**

This test procedure shall apply to the requirements set out in points 3.3 and 3.4 of Annex I to Regulation (EC) No 78/2009.

2. General

- 2.1. The headform impactors for the bonnet top tests shall be in 'free flight' at the moment of impact. The impactors shall be released to free flight at such a distance from the vehicle that the test results are not influenced by contact of the impactors with the propulsion system during rebound of the impactors.
- 2.2. The impactors may be propelled by an air, spring or hydraulic gun, or by other means that can be shown to give the same result.

3. Specification of the test

- 3.1. The purpose of the test is to ensure that the requirements set out in points 3.3 and 3.4 of Annex I to Regulation (EC) No 78/2009 are fulfilled.
 - 3.1.1. A minimum of nine tests shall be carried out with each headform impactor, three tests each to the middle and the outer thirds of the adult and child/small adult bonnet top test areas respectively, at positions judged to be the most likely to cause injury. Tests to the forward section of the bonnet top test area, as defined in point 3.2 shall be with a child/small adult headform impactor. Tests to the rearward section of the bonnet top test area defined, as in point 3.3 shall be with an adult headform impactor. Tests shall be to different types of structure, where these vary throughout the area to be assessed and at positions judged to be the most likely to cause injury.
- 3.2. The selected test points for the child/small adult headform impactor shall be:
 - (a) a minimum of 165 mm apart;
 - (b) a minimum of 82,5 mm inside the defined side reference lines;
 - (c) a minimum of 82,5 mm forward of the defined bonnet rear reference line or forward of a wrap around distance of 1 700 mm, whichever is most forward at the selected test point;
 - (d) a minimum of 82,5 mm rearward of the bonnet leading edge reference line or rearward of a wrap around distance of 1 000 mm whichever is more rearward at the selected test point.
- 3.3. The selected test points for the adult headform impactor shall be
 - (a) a minimum of 165 mm apart;
 - (b) a minimum of 82,5 mm inside the defined side reference lines;
 - (c) a minimum of 82,5 mm forwards of the defined bonnet rear reference line or forward of a wrap around distance of 2 100 mm, whichever is most forward at the selected test point;
 - (d) a minimum of 82,5 mm rearward of the defined bonnet leading edge reference line or rearward of a wrap around distance of 1 700 mm, whichever is most rearward at the selected test point.
- 3.3.1. The test points shall be located so that the impactor is not expected to impact the bonnet top with a glancing blow and then impact the windscreen or an A-pillar more severely. The minimum distances are to be set with a flexible tape held tautly along the outer surface of the vehicle. If a number of test positions have been selected and the test area remaining is too small to select another test position while maintaining the minimum spacing between tests, then less than nine tests may be performed. The positions tested by the laboratories shall be indicated in the test report. However, the technical services conducting the tests shall perform as many tests as necessary to guarantee the compliance of the vehicle with the head protection criteria (HPC) limit values of 1 000 for the HPC1000 impact zone and 1 700 for the HPC1700 impact zone, especially in the points near to the borders between the two types of zones.

- 3.3.2. Identification of HPC1000 and HPC1700 impact zones. The manufacturer shall identify the impact zones of the bonnet top where the head protection criterion (HPC) shall not exceed 1 000 (HPC1000 zone) respectively 1 700 (HPC1700 zone), in accordance with the requirements set out in point 3.5 of Annex I to Regulation (EC) No 78/2009.

Figure 9

Marking of HPC1000 and HPC1700 zones

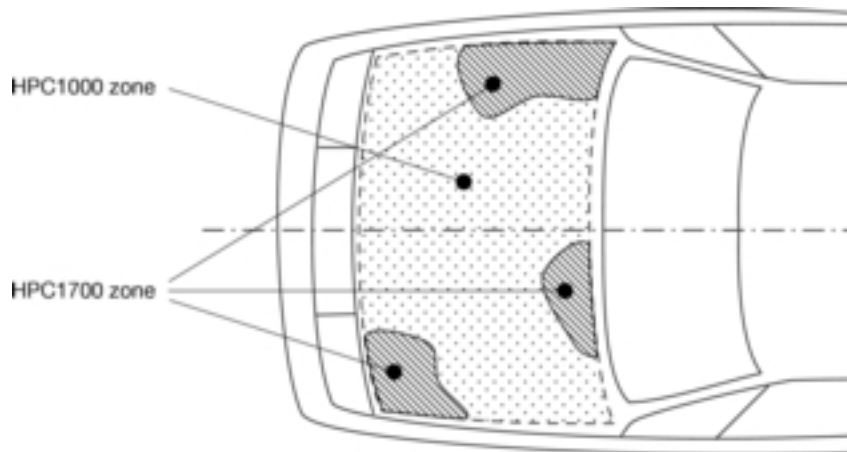

- 3.3.3. Marking of the bonnet top impact area as well as the impact zones will be based on a drawing, supplied by the manufacturer, showing a view from a horizontal plane above the vehicle that is parallel to the plane on which the vehicle is standing. A sufficient number of x and y coordinates shall be supplied by the manufacturer to mark up the areas on the actual vehicle while considering the vehicle outer contour in the z direction. The areas of the HPC1000 and HPC1700 zones may each consist of several parts, with the number of these parts not being limited. The calculation of the surface of the impact area as well as the surface areas of the impact zones shall be done on the basis of a projected bonnet when viewed from a horizontal plane parallel to the horizontal zero plane above the vehicle, on the basis of the drawing data supplied by the manufacturer.

4. Test procedure

- 4.1. The state of the vehicle or subsystem shall comply with the requirements of Chapter I. The stabilised temperature of the test apparatus and the vehicle or sub-system shall be $20\text{ °C} \pm 4\text{ °C}$.
- 4.2. The child/small adult and adult impactors to be used for the purposes of these tests shall be the ones as described in Sections 3 and 4 of Part V.
- 4.3. The impactors shall be mounted, propelled and released as specified in points 2.1 and 2.2.
- 4.4. For tests at the rear of the bonnet top the headform impactor shall not contact the windscreen or A-pillar before impacting the bonnet top.
- 4.4.1. The direction of impact shall be on a vertical longitudinal plane of the vehicle through the point to be tested. The tolerance for this direction is $\pm 2^\circ$. The direction of impact of tests to the bonnet top shall be downward and rearward, as if the vehicle were on the ground. The angle of impact for tests with the child headform impactor shall be $50^\circ \pm 2^\circ$ to the Ground Reference Level. The angle of impact for tests with the adult headform impactor shall be $65^\circ \pm 2^\circ$ to the Ground Reference Level. The effect of gravity shall be taken into account when the impact angle is obtained from measurements taken before the time of first contact.
- 4.5. At the time of first contact, the point of contact of the headform impactor shall be within a $\pm 10\text{ mm}$ of the selected impact location.
- 4.6. The impact velocity of the headform impactors when striking the bonnet top shall be $9,7 \pm 0,2\text{ m/s}$.
- 4.6.1. The velocity of the headform impactor shall be measured at some point during the free flight before impact, in accordance with the method specified in ISO 3784:1976. The accuracy of velocity measurement shall be $\pm 0,01\text{ m/s}$. The measured velocity shall be adjusted considering all factors which may affect the impactor between the point of measurement and the point of impact, in order to determine the velocity of the impactor at the time of impact.

- 4.7. The acceleration time histories shall be recorded, and HIC shall be calculated. The first point of contact on the front structure of the vehicle shall be recorded. Recording of test results shall be in accordance with ISO 6487:2002.

PART III

BRAKE ASSIST SYSTEMS SPECIFICATION

1. General

The purpose of this Part is to ensure compliance with the test requirements for the verification of Brake Assist Systems, as required by Section 4 of Annex I to Regulation (EC) No 78/2009.

1.1. Performance characteristics for Category 'A' BAS systems

When an emergency condition has been sensed by a relatively high pedal force, the additional pedal force to cause full cycling of the ABS shall be reduced compared to the pedal force required without the BAS in operation.

Compliance with this requirement is demonstrated if the provisions of points 7.1 to 7.3 are met.

1.2. Performance characteristics for Category 'B' and Category 'C' BAS systems.

When an emergency condition has been sensed, at least by a very fast application of the brake pedal, the BAS shall raise the pressure to deliver the maximum achievable braking rate or to cause full cycling of the ABS.

The requirement set out in this point shall be complied with if the provisions of points 8.1 to 8.3 are met.

2. For the purposes of this Part, the following definitions shall apply:

- 2.1. 'Category A Brake Assist System' means a system which detects an emergency braking condition based on the brake pedal force applied by the driver;
- 2.2. 'Category B Brake Assist System' means a system which detects an emergency braking condition based on the brake pedal speed applied by the driver;
- 2.3. 'Category C Brake Assist System' means a system which detects an emergency braking condition based on multiple criteria, one of which shall be the rate at which the brake pedal is applied.

3. Requirements

Whilst performing the tests set out in this Part, the following variables shall be measured:

- 3.1. Brake pedal force, F_p , applied at the centre of the brake pedal plate following a tangential arc to the brake pedal pivot;
- 3.2. Vehicle longitudinal velocity, v_x ;
- 3.3. Vehicle longitudinal acceleration, a_x ;
- 3.4. Brake temperature, T_d , measured on the surface of the braking path of the disc or drum of the front brakes;
- 3.5. Brake pressure, P , where applicable;
- 3.6. Brake pedal travel, S_p , measured at the centre of the pedal plate or at a position on the pedal mechanism where the displacement is proportional to the displacement at the centre of the pedal plate allowing simple calibration of the measurement.

4. Measurements

4.1. The variables listed in Section 3 shall be measured by means of appropriate transducers. Accuracy, operating ranges, filtering techniques, data processing and other requirements are described in ISO Standard 15037-1:2006.

4.2. Accuracy of pedal force and disc temperature measurements shall be as follows:

Measurement	Typical operating range of the transducers	Recommended maximum recording errors
Pedal force	0 to 2 000 N	± 10 N
Brake disc temperature	0-1 000 °C	± 5 °C
Brake Pressure (*)	0-20 MPa (*)	± 100 kPa (*)

(*) Applicable as specified in point 7.2.5.

4.2.1. A sampling rate for data acquisition of at least 500 Hz is required.

4.2.2. Further details on analogue and digital data processing of the BAS test procedures are described in Appendix II to this Part.

4.2.3. Alternative measuring methods to those referred to above may be allowed, provided they demonstrate at least an equivalent level of precision.

5. Test Conditions

5.1. Test vehicle loading condition:

The vehicle shall be unladen. There may be, in addition to the driver, a second person on the front seat who is responsible for noting the results of the tests.

6. Test Method

6.1. The tests as described in Sections 7 and 8 shall be carried out from a starting test speed of 100 ± 2 km/h. The vehicle shall be driven at the test speed in a straight line.

6.2. The average temperature of the front brakes shall be measured, in accordance with point 3.4 and recorded before each test and shall lie between 65 °C and 100 °C prior to any test.

6.3. The braking tests shall be performed on a dry asphalt test track in accordance with ISO Standard 15037-1:1998.

6.4. For the tests, the reference time, t_0 , is defined as the moment when the brake pedal force reaches 20N.

Note:

For vehicles equipped with a brake system assisted by an energy source, the applied pedal force necessary depends on the energy level that exists in the energy storage device. Therefore, sufficient energy level shall be ensured at the beginning of the test.

7. Assessment of the Presence of a Category 'A' BAS

A Category 'A' BAS shall meet the test requirements contained in Sections 7.1 and 7.2.

7.1. *Test 1: Reference test to determine F_{ABS} and a_{ABS}*

7.1.1. The reference values F_{ABS} and a_{ABS} shall be determined in accordance with the procedure described in Appendix I.

- 7.2. Test 2: For activation of BAS
- 7.2.1. Once an emergency braking condition has been detected, systems sensitive to pedal force shall show a significant increase in the ratio of:
- brake line pressure to brake pedal force, where permitted by point 7.2.5 or
 - vehicle deceleration to brake pedal force.
- 7.2.2. The performance requirements for a Category 'A' BAS are met if a specific brake application characteristic can be defined that exhibits a decrease of between 40 % and 80 % in required brake pedal force for ($F_{ABS} - F_T$) compared to ($F_{ABS, extrapolated} - F_T$).
- 7.2.3. F_T and a_T are threshold force and threshold deceleration as shown in Figure 1. The values of F_T and a_T shall be supplied to the Technical Service at the time of submission of the type-approval application. The value of a_T shall be between $3,5\text{m/s}^2$ and $5,0\text{m/s}^2$.
- 7.2.4. A straight line is drawn from the origin through the point F_T, a_T (as shown in Figure 1a). The value of brake pedal force 'F', at the point of intersection between this line and a horizontal line defined by $a = a_{ABS}$, is defined as $F_{ABS, extrapolated}$:

$$F_{ABS, extrapolated} = \frac{F_T \times a_{ABS}}{a_T}$$

- 7.2.5. As an alternative, which can be selected by the manufacturer, in the case of vehicles of GVM > 2 500 kg of category N_1 , or M_1 derived from those N_1 vehicles, the pedal force figures for $F_T, F_{ABS, min}, F_{ABS, max}$ and $F_{ABS, extrapolated}$ may be derived from the brake line pressure response characteristic instead of the vehicle deceleration characteristic. This shall be measured as the brake pedal force is increasing.
- 7.2.5.1. The pressure, at which ABS cycling commences, shall be determined by making five tests from 100 ± 2 km/h in which the brake pedal is applied up to the level which produces ABS operation and the five pressures at which this occurs as determined from front wheel pressure records, shall be recorded and the mean value obtained as p_{abs} .
- 7.2.5.2. The threshold pressure P_T shall be stated by the manufacturer and correspond to a deceleration in the range of $2,5\text{--}4,5$ m/s^2 .
- 7.2.5.3. Figure 1b shall be constructed in the manner set out in point 7.2.4 but using line pressure measurements to define the parameters set out in point 7.2.5 above where:

$$F_{ABS, extrapolated} = \frac{F_T \times P_{ABS}}{P_T}$$

Figure 1a

Pedal force characteristic needed in order to achieve maximum deceleration with category 'A' BAS

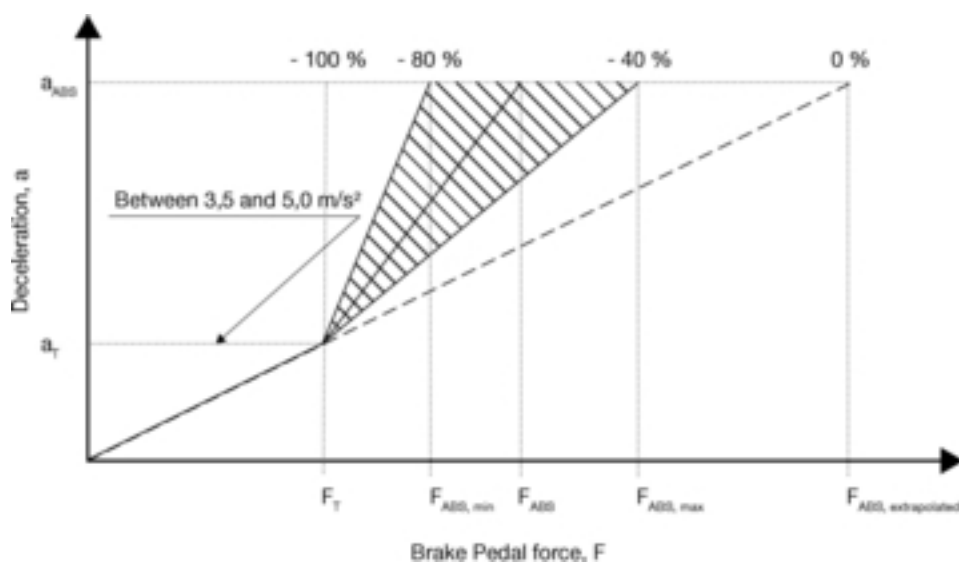
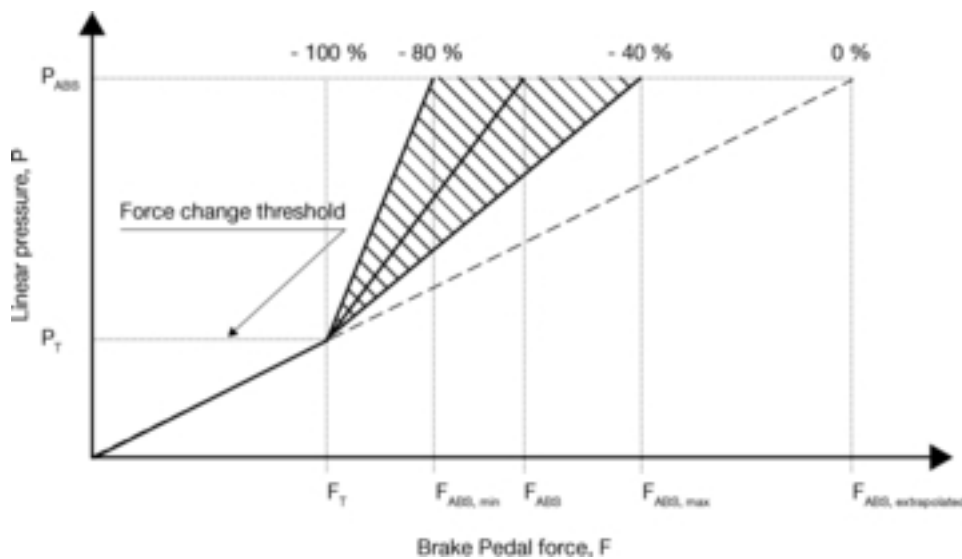

Figure 1b

Pedal force characteristic needed in order to achieve maximum deceleration with category 'A' BAS



7.3. Data evaluation

The presence of a Category 'A' BAS is proven if

$$F_{ABS, \min} \leq F_{ABS} \leq F_{ABS, \max}$$

where,

$$F_{ABS, \max} - F_T \leq (F_{ABS, \text{extrapolated}} - F_T) \times 0,6$$

and

$$F_{ABS, \min} - F_T \geq (F_{ABS, \text{extrapolated}} - F_T) \times 0,2$$

8. Assessment of the Presence of a Category 'B' BAS

A Category 'B' BAS shall meet the test requirements contained within Sections 8.1 and 8.2 of this Part.

8.1. Test 1: Reference test to determine F_{ABS} and a_{ABS}

8.1.1. The reference values F_{ABS} and a_{ABS} shall be determined in accordance with the procedure described in Appendix I.

8.2. Test 2: For activation of BAS

8.2.1. The vehicle shall be driven in a straight line at the test starting speed specified in 6.1. The driver shall apply the brake pedal quickly according to Figure 2, simulating emergency braking so that BAS is activated and ABS is fully cycling.

8.2.2. In order to activate BAS the brake pedal shall be applied as specified by the vehicle manufacturer. The manufacturer shall notify the Technical Service of the required brake pedal input at the time of submission of the application for type-approval. It shall be demonstrated to the satisfaction of the Technical Service that the BAS activates under the conditions specified by the manufacturer as follows:

8.2.2.1. For category B systems, definition of the brake pedal speed which shall be achieved in order to activate the Brake Assist System (e.g. pedal stroke speed 9 mm/s) during a given time interval).

8.2.2.2. For category C systems, definition of the input variables affecting the decision to activate the Brake Assist System, the relationship between them and the pedal application required to activate the Brake Assist System for the tests described in this Part.

- 8.2.3. After $t = t_0 + 0,8$ s and until the vehicle has slowed down to a speed of 15 km/h, the brake pedal force shall be maintained in a corridor between $F_{ABS, upper}$ and $F_{ABS, lower}$. Where $F_{ABS, upper}$ is $0,7 \times F_{ABS}$ and $F_{ABS, lower}$ is $0,5 \times F_{ABS}$.
- 8.2.4. The requirements also are considered to be met if, after $t = t_0 + 0,8$ s, the pedal force falls below $F_{ABS, lower}$ provided the requirement of point 8.3 is fulfilled.
- 8.3. *Data evaluation*

The presence of BAS category 'B' is proven if a mean deceleration of at least $0,85 \times a_{ABS}$ is maintained from the time when $t = t_0 + 0,8$ s to the time when the vehicle speed has been reduced to 15 km/h.

Figure 2

Example of test 2 of a Category 'B' BAS system.

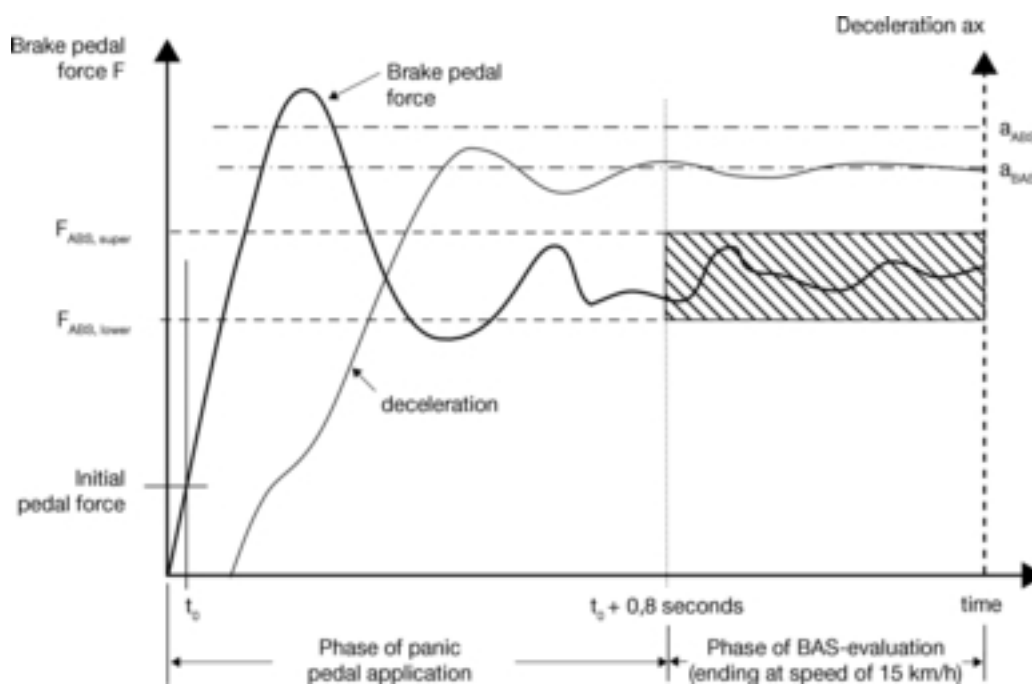

9. Assessment of the Presence of a Category 'C' BAS.

- 9.1. A Category 'C' BAS shall meet the test requirements of points 8.2 and 8.3
- 9.2. *Data evaluation*

A Category 'C' BAS shall meet the requirements of point 8.3.

Appendix I

Method for Determination of F_{ABS} and a_{ABS}

1. The brake pedal force F_{ABS} is the minimum pedal force that has to be applied for a given vehicle in order to achieve maximum deceleration which indicates that ABS is fully cycling. a_{ABS} is the deceleration for a given vehicle during ABS deceleration as defined in point 7.
2. The brake pedal shall be applied slowly (without activating the Brake Assist System in the case of category B or category C systems) providing a constant increase of deceleration until ABS is fully cycling (Figure 3).
3. The full deceleration shall be reached within the timeframe of $2,0 \pm 0,5$ s. The deceleration curve, recorded against time, shall be within a corridor of $\pm 0,5$ s around the centre line of the deceleration curve corridor. The example in Figure 3 has its origin at the time t_0 crossing the a_{ABS} line at 2 seconds. Once full deceleration has been achieved, the pedal travel, S_p , shall not be decreased for at least 1 s. The time of full activation of the ABS system is defined as the time when pedal force F_{ABS} is achieved. The measurement shall be within the corridor for variance of deceleration increase (see Figure 3).

Figure 3

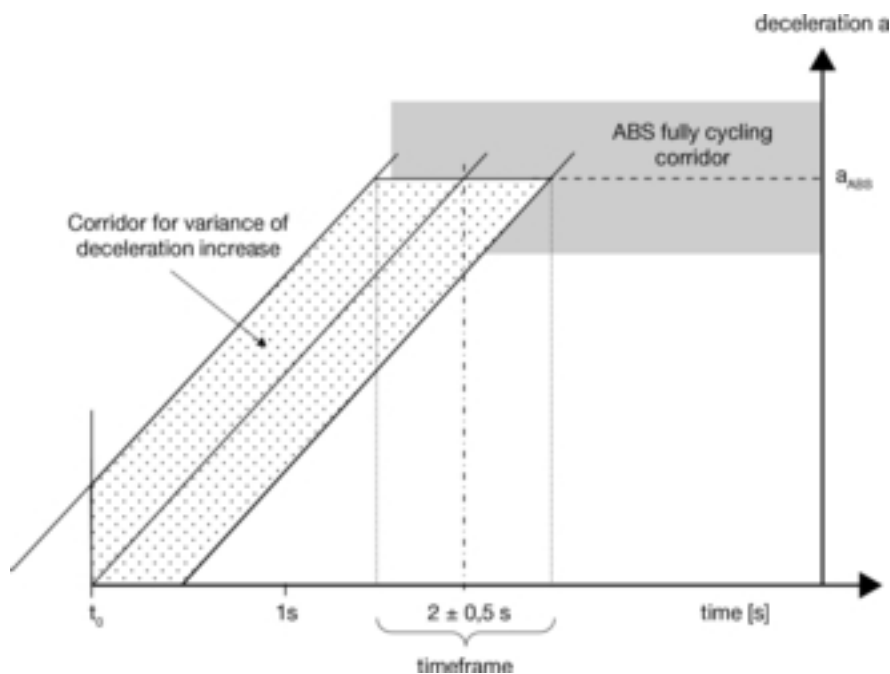
Deceleration corridor for determination of F_{ABS} and a_{ABS} 

4. Five tests meeting the requirements of point 3 shall be carried out. For each of these valid tests the vehicle deceleration shall be plotted as a function of the recorded brake pedal force. Only data recorded at speeds above 15 km/h shall be taken for the calculations described in the following points.
5. For the determination of a_{ABS} and F_{ABS} a low-pass filter of 2 Hz for vehicle deceleration as well as pedal force shall be applied.
6. The five individual 'deceleration versus brake pedal force' curves are averaged by calculating the mean deceleration of the five individual 'deceleration vs. brake pedal force' curves at increments of 1 N pedal force. The result is the mean deceleration versus brake pedal force curve, which will be referred to as the 'maF curve' in this appendix.
7. The maximum value for the vehicle deceleration is determined from the 'maF curve' and is named as ' a_{max} '.
8. All values of the 'maF curve' that are above 90 per cent of this deceleration value ' a_{max} ' are averaged. This value of 'a' is the deceleration ' a_{ABS} ' referred to in this Part.
9. The minimum force on the pedal ($F_{ABS, min}$) sufficient to achieve the deceleration a_{ABS} calculated in point 7 is defined as the value of F corresponding to $a = a_{ABS}$ on the maF curve.

Appendix II

Data Processing for BAS**1. Analogue Data processing**

The bandwidth of the entire combined transducer/recording system shall be no less than 30 Hz.

In order to execute the necessary filtering of signals, low-pass filters of fourth order or higher shall be employed. The width of the pass band (from 0 Hz to frequency f_o at -3 dB) shall not be less than 30 Hz. Amplitude errors shall be less than $\pm 0,5$ % in the relevant frequency range of 0 Hz to 30 Hz. All analogue signals shall be processed with filters having sufficiently similar phase characteristics to ensure that time delay differences due to filtering lie within the required accuracy for time measurement.

Note:

During analogue filtering of signals with different frequency contents, phase shifts can occur. Therefore, a data processing method, as set out in Section 2, is preferable.

2. Digital Data Processing**2.1. General consideration**

Preparation of analogue signals includes consideration of filter amplitude attenuation and sampling rate to avoid aliasing errors, and filter phase lags and time delays. Sampling and digitising considerations include pre-sampling amplification of signals to minimize digitising errors; number of bits per sample; number of samples per cycle; sample and hold amplifiers; and time-wise spacing of samples. Considerations for additional phaseless digital filtering include selection of pass bands and stop bands and the attenuation and allowable ripple in each; and correction of filter phase lags. Each of these factors shall be considered in order to achieve a relative overall data acquisition accuracy of $\pm 0,5$ %.

2.2. Aliasing errors

In order to avoid uncorrectable aliasing errors, the analogue signals shall be appropriately filtered before sampling and digitising. The order of the filters used and their pass band shall be chosen according to both the required flatness in the relevant frequency range and the sampling frequency.

The minimum filter characteristics and sampling rate shall be such that

- (a) within the relevant frequency range of 0 Hz to $f_{\max} = 30$ Hz the attenuation is less than the resolution of the data acquisition system; and
- (b) at one-half the sampling frequency (i.e. the Nyquist or 'folding' frequency) the magnitudes of all frequency components of signal and noise are reduced to less than the system resolution.

For 0,05 % resolution the filter attenuation shall be less than 0,05 % in the frequency range between 0 and 30 Hz, and the attenuation shall be greater than 99,95 % at all frequencies greater than one-half the sampling frequency.

Note:

For a Butterworth filter the attenuation is given by:

$$A^2 = \frac{1}{1 + (f_{\max}/f_0)^{2n}} \text{ and } A^2 = \frac{1}{1 + (f_N/f_0)^{2n}}$$

where:

n is the filter order

f_{\max} is the relevant frequency range (30 Hz)

f_o is the filter cut-off frequency

f_N is the Nyquist or cut-off frequency.

For a fourth order filter

for $A = 0,9995$:

$$f_o = 2,37 \times f_{\max}$$

for $A = 0,0005$:

$$f_s = 2 \times (6,69 \times f_o), \text{ where } f_s, \text{ is the sampling frequency} = 2 \times f_N.$$

2.3. Filter phase shifts and time delays for anti-aliasing filtering

Excessive analogue filtering shall be avoided, and all filters shall have sufficiently similar phase characteristics to ensure that time delay differences are within the required accuracy for the time measurement. Phase shifts are especially significant when measured variables are multiplied together to form new variables, because while amplitudes multiply, phase shifts and associated time delays add. Phase shifts and time delays are reduced by increasing f_o . Whenever equations describing the pre-sampling filters are known, it is practical to remove their phase shifts and time delays by simple algorithms performed in the frequency domain.

Note:

In the frequency range in which the filter amplitude characteristics remain flat, the phase shift Φ of a Butterworth filter can be approximated by

$$\Phi = 81 \times (f/f_o) \text{ degrees for second order}$$

$$\Phi = 150 \times (f/f_o) \text{ degrees for fourth order}$$

$$\Phi = 294 \times (f/f_o) \text{ degrees for eighth order}$$

The time delay for all filter orders is: $t = (\Phi/360) \times (1/f_o)$

2.4. Data sampling and digitising

At 30 Hz the signal amplitude changes by up to 18 % per millisecond. To limit dynamic errors caused by changing analogue inputs to 0,1 %, sampling or digitising time shall be less than 32 μ s. All pairs or sets of data samples to be compared shall be taken simultaneously or over a sufficiently short time period.

2.5. System requirements

The data system shall have a resolution of 12 bits ($\pm 0,05$ %) or more and an accuracy of 2 LSB ($\pm 0,1$ %). Anti-aliasing filters shall be of order 4 or higher and the relevant data range f_{\max} shall be 0 Hz to 30 Hz.

For fourth order filters the pass-band frequency f_o (from 0 Hz to frequency f_o) shall be greater than $2,37 \times f_{\max}$ if phase errors are subsequently adjusted in digital data processing, and greater than $5 \times f_{\max}$ otherwise. For fourth order filters the data sampling frequency f_s shall be greater than $13,4 \times f_o$.

PART IV

FRONTAL PROTECTION SYSTEMS TEST SPECIFICATIONS

CHAPTER I

General conditions

1. **Frontal Protection System as original equipment fitted to a vehicle**
 - 1.1. The frontal protection system mounted on the vehicle shall comply with the conditions laid down in Section 6 of Annex I to Regulation (EC) No 78/2009.
 - 1.2. The vehicle shall be in its normal ride attitude and either securely mounted on raised supports or at rest on a flat surface with the handbrake on. The vehicle shall be fitted with the frontal protection system to be tested. The fitting instructions from the manufacturer of the frontal protection system shall be followed and these shall include tightening torques for all fixings.
 - 1.3. All devices designed to protect pedestrians and other vulnerable road users shall be correctly activated before and/or be active during the appropriate test. The applicant shall demonstrate that the devices will function as intended if the vehicle strikes a pedestrian or other vulnerable road user.
 - 1.4. Any vehicle component that could change shape or position, such as 'pop-up' headlamps, other than devices to protect pedestrians and other vulnerable road users, shall be set to a shape or position that the technical services consider to be most appropriate for these tests.
2. **Frontal Protection System as a separate technical unit**
 - 2.1. Where only a frontal protection system is supplied for tests, it shall be possible to comply with the conditions laid down in Section 6 of Annex I to Regulation (EC) No 78/2009 when fitted to the vehicle type to which the specific separate technical unit type-approval relates.
 - 2.2. The test may be carried out either with the frontal protection system mounted on a vehicle of the type for which it is intended or on a test frame closely representing the essential outer front end dimensions of the intended vehicle type. If, when using a test frame, the frontal protection system makes contact with the frame during testing, the test shall be repeated with the frontal protection system mounted on the actual vehicle type for which it is intended. In the case of testing carried out when the frontal protection system is mounted on a vehicle the conditions of Section 1 shall apply.
3. **Information to be provided**
 - 3.1. All frontal protection systems, whether being part of the type-approval of a vehicle with regard to it being fitted with a frontal protection system or being type-approved as a separate technical unit, shall be accompanied by information as to the vehicle or vehicles on which it has been approved for fitting.
 - 3.2. All frontal protection systems type-approved as separate technical units shall be accompanied by detailed installation instructions giving sufficient information for a competent person to install it on the vehicle properly. The instructions shall be in the language or languages of the Member State in which the frontal protection system will be offered for sale.

CHAPTER II

Lower Legform to Frontal Protection System test**1. Scope**

This test procedure shall apply to the requirements set out in point 5.1.1 of Annex I to Regulation (EC) No 78/2009.

2. General

2.1. The Lower Legform impactor for the frontal protection system tests shall be in 'free flight' at the moment of impact. The impactor shall be released to free flight at such a distance that the test results are not influenced by any contact of the impactor with the propulsion system during rebound of the impactor.

2.2. In all cases the impactor may be propelled by an air, spring or hydraulic gun, or by other means that can be shown to give the same result.

3. Specification of the test

3.1. A minimum of three Lower Legform to frontal protection system tests shall be carried out on test points between the Upper and Lower Frontal protection System Reference Lines. The test points shall be at positions judged by the test authority to be the most likely to cause injury. Tests shall be carried out to different types of structure where they vary throughout the area to be assessed. The points tested by the technical services shall be indicated in the test report.

3.2. For vehicles with a lower frontal protection system reference line height of less than 425 mm the requirements of this test shall be applied.

For vehicles with a lower frontal protection system reference line height which is both equal to, or greater than, 425 mm and less than 500 mm the requirements of Chapter III may be applied, at the choice of the manufacturer.

For vehicles with a lower frontal protection system reference line height of equal to or greater than 500 mm the requirements of Chapter III shall be applied.

4. Test procedure

4.1. The state of the vehicle or subsystem shall comply with the requirements of Chapter I.

4.1.1. The test impactor or at least the foam flesh shall be stored during a period of at least four hours in a controlled storage area with a stabilised humidity of 35 percent \pm 15 percent and a stabilised temperature of 20 \pm 4 °C prior to impactor removal for testing. After removal from the storage the impactor shall not be subjected to conditions other than those existing in the test area.

4.1.2. Each test shall be completed within two hours of when the impactor to be used is removed from the controlled storage area.

4.2. The lower legform impactor is described in Section 1 of Part V.

4.3. The impactor shall be mounted and propelled as set out in points 2.1 and 2.2.

4.4. The direction of impact shall be in the horizontal plane and parallel to the longitudinal vertical plane of the frontal protection system as mounted on the vehicle or test frame. The tolerance for the direction of the velocity vector in the horizontal plane and in the longitudinal plane shall be \pm 2° at the time of first contact.

4.5. The axis of the impactor shall be perpendicular to the horizontal plane with a tolerance of \pm 2° in the lateral and longitudinal plane. The horizontal, longitudinal and lateral planes are orthogonal to each other (see Figure 2).

4.6. The bottom of the impactor shall be 25 mm above Ground Reference Level at the time of first contact with the frontal protection system (see Figure 1), with a \pm 10 mm tolerance.

When setting the height of the propulsion system, an allowance shall be made for the influence of gravity during the period of free flight of the impactor.

- 4.7. At the time of first contact the impactor shall have the intended orientation about its vertical axis, for the correct operation of its knee joint, with a tolerance of $\pm 5^\circ$.
- 4.8. At the time of the first contact the centre line of the impactor shall be within ± 10 mm tolerance to the selected impact position.
- 4.9. During contact between the impactor and the frontal protection system, the impactor shall not contact the ground or any object which is not part of the frontal protection system or the vehicle.
- 4.10. The impact velocity of the impactor when striking the frontal protection system shall be $11,1 \pm 0,2$ m/s. The effect of gravity shall be taken into account when the impact velocity is obtained from measurements taken before the time of first contact.

Figure 1

Lower legform to frontal protection system tests for complete vehicle in normal ride attitude (left), for complete vehicle on supports (centre) or separate technical unit mounted on test frame (right) (as alternative to separate technical unit mounted on vehicle)

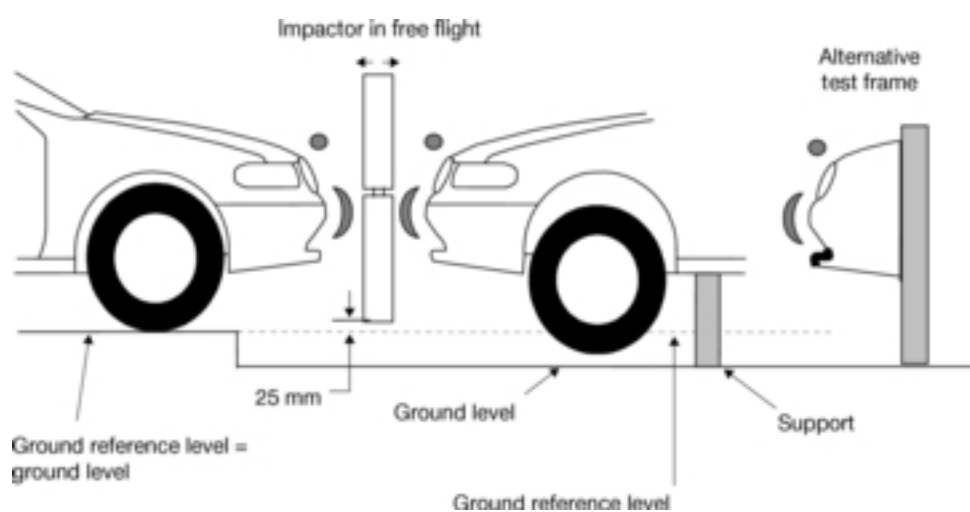
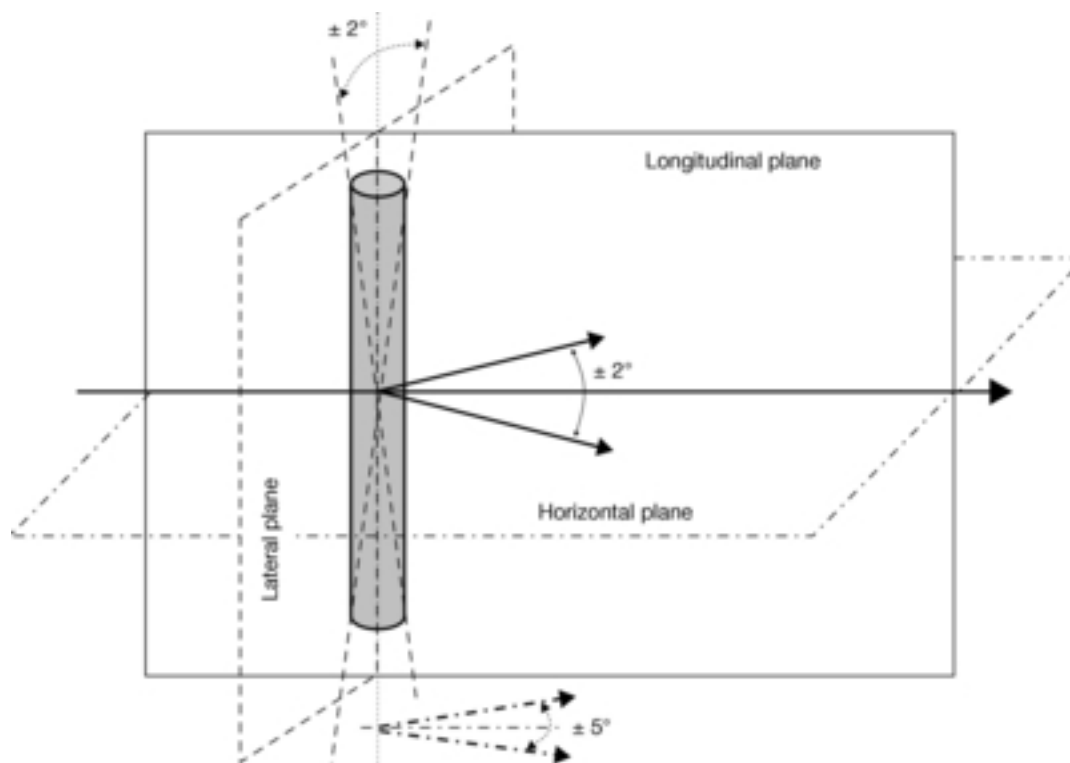

Figure 2

Tolerances of angles for the lower legform impactor at the time of first impact



CHAPTER III

Upper Legform to Frontal Protection System test**1. Scope**

- 1.1. This test procedure shall apply to the requirements set out in Section 5.1.2 of Annex I to Regulation (EC) No 78/2009.

2. General

- 2.1. The Upper Legform impactor for tests to the frontal protection system shall be mounted to the propulsion system, by a torque limiting joint, to prevent large off-centre loads damaging the guidance system. The guidance system shall be fitted with low-friction guides, insensitive to off-axis loading, that allow the impactor to move only in the specified direction of impact, when in contact with the frontal protection system. The guides shall prevent motion in other directions including rotation about any other axis.
- 2.2. The impactor may be propelled by an air, spring or hydraulic gun, or by other means that can be shown to give the same result.

3. Specification of the test

- 3.1. A minimum of three Upper Legform to frontal protection system tests shall be carried out on test points between the Upper and Lower Frontal protection System Reference Lines. The test points shall be at positions judged by the test authority to be the most likely to cause injury. Tests shall be carried out to different types of structure where they vary throughout the area to be assessed. The points tested by the technical services shall be indicated in the test report.
- 3.2. For vehicles with a lower frontal protection system reference line height of less than 425 mm the requirements of Chapter II shall apply.

For vehicles with a lower frontal protection system reference line height which is both equal to, or greater than, 425 mm and less than 500 mm the requirements of Chapter II may be applied, at the choice of the manufacturer.

For vehicles with a lower frontal protection system reference line height equal to, or greater than, 500 mm the requirements of this test shall apply.

4. Test procedure

- 4.1. The state of the vehicle or subsystem shall comply with the requirements of Chapter I.
- 4.1.1. The test impactor or at least the foam flesh shall be stored during a period of at least four hours in a controlled storage area with a stabilised humidity of 35 percent \pm 15 percent and a stabilised temperature of 20 \pm 4 °C prior to impactor removal for testing. After removal from the storage the impactor shall not be subjected to conditions other than those existing in the test area.
- 4.1.2. Each test shall be completed within two hours of when the impactor to be used is removed from the controlled storage area.
- 4.2. The upper legform impactor is described in Section 2 of Part V.
- 4.3. The impactor shall be mounted and propelled as specified in points 2.1 and 2.2.
- 4.4. The direction of impact shall be parallel to the longitudinal axis of the frontal protection system as mounted on the vehicle or test frame, with the axis of the upper legform vertical at the time of first contact. The tolerance to these directions shall be \pm 2°. At the time of first contact the impactor centre line shall be coincident with the selected test point with a \pm 10 mm tolerance both laterally and vertically.
- 4.5. The impact velocity of the impactor when striking the frontal protection system shall be 11,1 \pm 0,2 m/s.

CHAPTER IV

Upper Legform to Frontal Protection System Leading Edge test**1. Scope**

- 1.1. This test shall apply to the requirements set out in Section 5.2. of Annex I to Regulation (EC) No 78/2009.

2. General

- 2.1. The Upper Legform impactor for tests to the frontal protection system Leading Edge shall be mounted to the propulsion system, by a torque limiting joint, to prevent large off-centre loads damaging the guidance system. The guidance system shall be fitted with low-friction guides, insensitive to off-axis loading, that allow the impactor to move only in the specified direction of impact, when in contact with the frontal protection system. The guides shall prevent motion in other directions including rotation about any other axis.
- 2.2. In all cases the impactors may be propelled by an air, spring or hydraulic gun, or by other means that can be shown to give the same result.

3. Specification of the test

- 3.1. A minimum of three tests shall be carried out to the frontal protection system Leading Edge Reference Line, at points judged by the test authority to be the most likely to cause injury. Tests shall be to different types of structure where they vary throughout the area to be assessed. The points tested by the technical services shall be indicated in the test report.

4. Test procedure

- 4.1. The state of the vehicle or subsystem shall comply with the requirements of Chapter I.
- 4.1.1. The test impactor or at least the foam flesh shall be stored during a period of at least four hours in a controlled storage area with a stabilised humidity of 35 percent \pm 15 percent and a stabilised temperature of 20 \pm 4 °C prior to impactor removal for testing. After removal from the storage the impactor shall not be subjected to conditions other than those existing in the test area.
- 4.1.2. Each test shall be completed within two hours of when the impactor to be used is removed from the controlled storage area.
- 4.2. The upper legform impactor is described in Section 2 of Part V.
- 4.3. The impactor shall be mounted and propelled as specified in points 2.1 and 2.2.
- 4.4. The impactor shall be aligned in such a way that the centre line of the propulsion system and the longitudinal axis of the impactor are parallel to the longitudinal plane of the frontal protection system as mounted on the vehicle or test frame. The tolerances to these directions are \pm 2°. At the time of first contact the impactor centre line shall be coincident with the selected impact position with a \pm 10 mm tolerance (see Figure 3), and laterally with a tolerance of \pm 10 mm.
- 4.5. The required impact velocity, the angle of impact and the impactor mass are determined in accordance with points 4.6. and 4.8.1. The tolerance on the impact velocity is \pm 2 % and the tolerance on the impact direction is \pm 2°. The effect of gravity is taken into account before the time of first contact. The impactor mass shall be measured to an accuracy of better than \pm 1 %, and if the measured value differs from the required value then the required velocity shall be adjusted to compensate, in accordance with point 4.8.1.
- 4.6. The required impact velocity and the angle of impact are determined from Figures 4 and 5 with reference to the vertical height of the intended impact position on the Frontal Protection System Leading Edge Reference Line and the Frontal Protection System Lead.
- 4.7. The required impactor test energy shall be determined by reference to Figure 6.

4.8. The total mass of the impactor includes those propulsion and guidance components which are effectively part of the impactor during the impact, including the extra weights.

4.8.1. Calculate the required test value of the impactor mass from:

$$M = 2E / V^2$$

where

M = Resultant Mass [kg]

E = Impact Energy [J]

V = Velocity [m/s]

The required velocity shall be the value derived in point 4.6. and the energy shall be derived from Figure 6. with reference to the values of frontal protection system leading edge height and frontal protection system lead on the vertical longitudinal plane through the intended point of impact.

The impactor mass may be adjusted from the calculated value by $\pm 10\%$, provided the required impact velocity is also changed using the above formula to maintain the required impactor kinetic energy.

4.9. Fit the required extra weights to give the calculated value of impactor mass, determined in point 4.8.1, to the rear of the rear member of the impactor, or to components of the guidance system which are effectively part of the impactor during the impact.

Figure 3

Upper Legform to Frontal Protection System Leading Edge tests

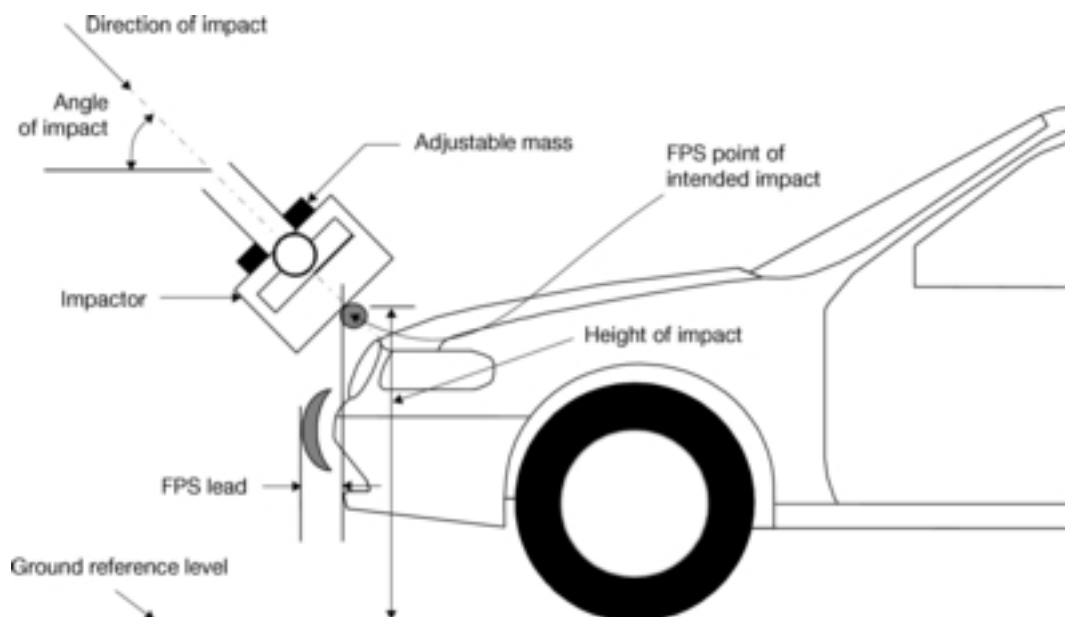
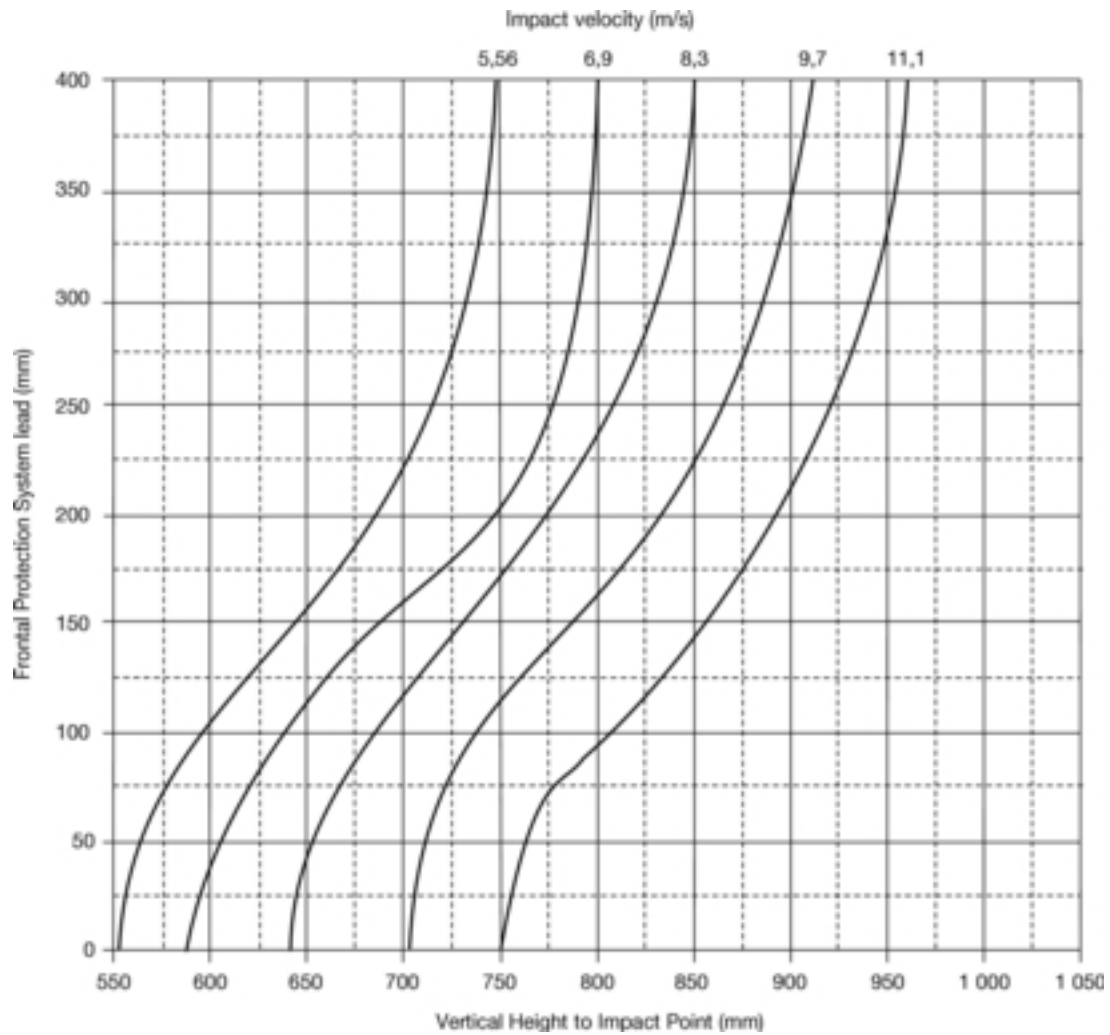

Figure 4
Velocity of Upper Legform to Frontal Protection System Leading Edge



Notes:

1. Interpolate horizontally between curves.
2. With configurations below 5,56 m/s — test at 5,56 m/s.
3. With configurations above 11,1 m/s — test at 11,1 m/s.
4. With negative FPS leads — test as for zero lead.
5. With FPS leads above 400 mm — test as for 400 mm.

Figure 5

Angle of Impact for Upper Legform to Frontal Protection System Leading Edge

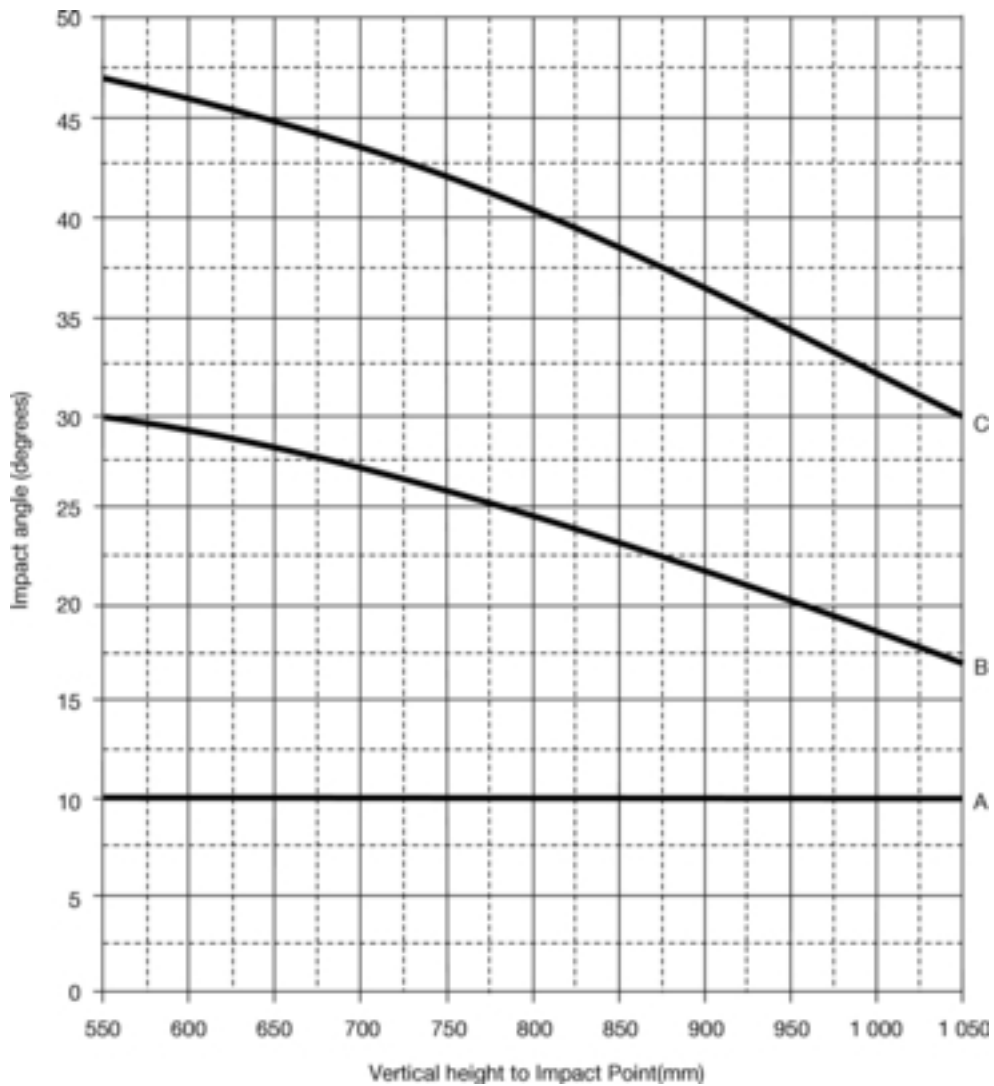

Key:

- A = 0 mm FPS lead
- B = 50 mm FPS lead
- C = 150 mm FPS lead

Notes:

1. Interpolate vertically between curves.
2. With negative FPS leads
— test as for zero FPS lead.
3. With FPS leads above 150 mm
— test as for 150 mm.
4. With impact point heights above 1 050 mm
— test as for 1 050 mm.

Figure 6

Kinetic energy of Impact for Upper Legform to Frontal Protection System Leading Edge

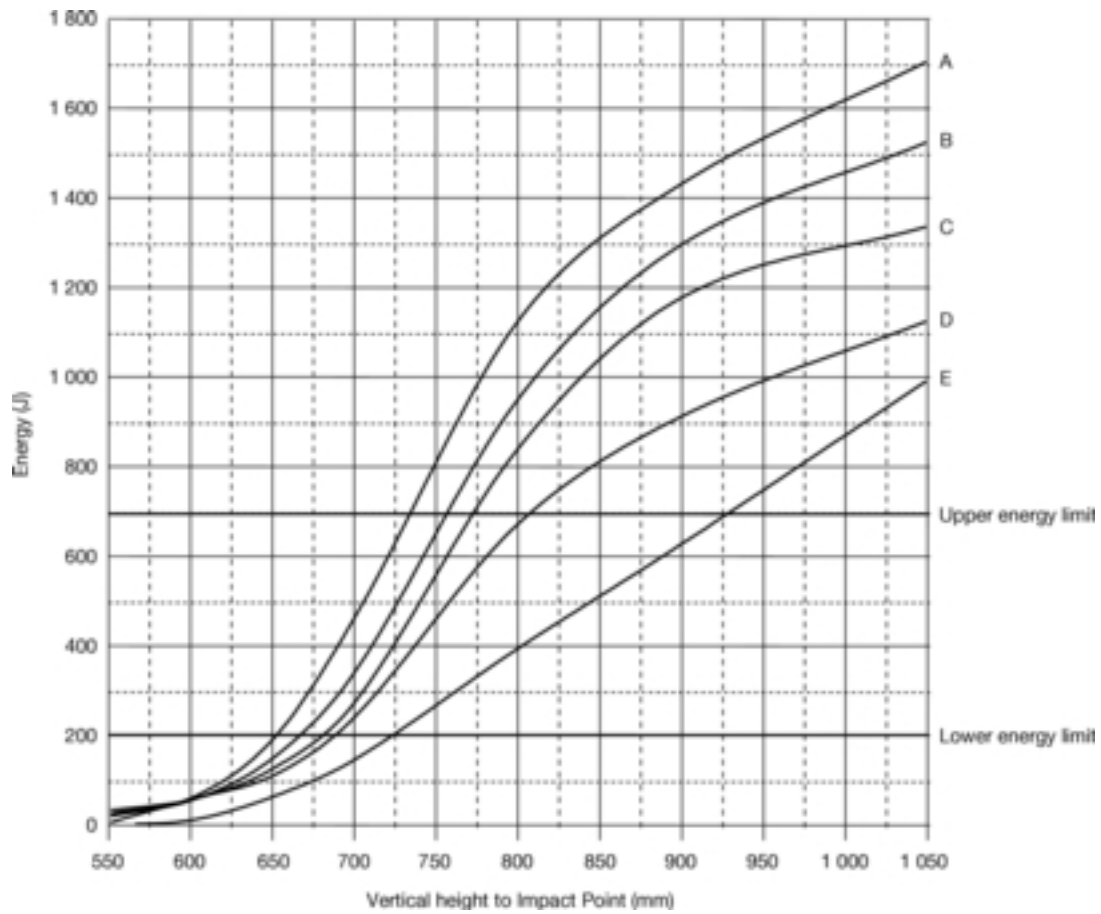

Key:

- A = 50 mm FPS lead
- B = 100 mm FPS lead
- C = 150 mm FPS lead
- D = 250 mm FPS lead
- E = 350 mm FPS lead

Notes

1. Interpolate vertically between curves.
2. With FPS leads below 50 mm test as for 50 mm.
3. With FPS leads above 350 mm test as for 350 mm.
4. With impact point heights above 1 050 mm test as for 1 050 mm.
5. With a required kinetic energy above 700 J test at 700 J.
6. With a required kinetic energy equal to or below 200 J test at 200 J.

CHAPTER V

Child/Small Adult headform to Frontal Protection System test**1. Scope**

- 1.1. This test procedure shall apply to the requirements set out in point 5.3 of Annex I to Regulation (EC) No 78/2009.

2. General

- 2.1. The child/small adult headform impactor for the frontal protection system tests shall be in 'free flight' at the moment of impact. The impactor shall be released to free flight at such a distance from the frontal protection system that the test results are not influenced by any contact of the impactor with the propulsion system during rebound of the impactor.
- 2.2. In all cases the impactors may be propelled by an air, spring or hydraulic gun, or by other means that can be shown to give the same result.

3. Specification of the test

- 3.1. A minimum of three headform impact tests shall be carried out at positions which are judged by the test laboratories to be the most likely to cause injury. Tests shall be to different types of structure, where these vary throughout the area to be assessed. Points tested by the technical services shall be indicated in the test report.
- 3.2. Test points for the child/small adult headform impactor shall be chosen on parts of the frontal protection system where the frontal protection system wrap around distance exceeds 900 mm with the vehicle in its normal ride attitude or with the frontal protection system mounted on a test frame representing the vehicle to which it is to be fitted as if in its' normal ride attitude.

4. Test procedure

- 4.1. The state of the vehicle or subsystem shall comply with the requirements of Chapter I of this Part. The stabilised temperature of the test apparatus and the vehicle or separate technical unit shall be 20 ± 4 °C.
- 4.2. The child/small adult headform impactor is described in Section 3 of Part V.
- 4.3. The impactor shall be mounted and propelled as specified in points 2.1. and 2.2.
- 4.4. The direction of impact shall be on a vertical longitudinal plane through the frontal protection system through the point to be tested. The tolerance for this direction is $\pm 2^\circ$. The direction of impact shall be downwards and rearwards at an angle of $50^\circ \pm 2^\circ$ to the ground reference level. The effect of gravity shall be taken into account when the impact angle is obtained from measurements taken before the time of first contact.
- 4.5. At the time of first contact, the point of first contact of the impactor shall be within a ± 10 mm tolerance to the selected impact point.
- 4.6. The impact velocity of the impactor when striking the impact position shall be $9,7 \pm 0,2$ m/s.
- 4.6.1. The velocity of the headform impactor shall be measured at some point during the free flight before impact, in accordance with the method specified in ISO 3784:1976. The accuracy of velocity measurement shall be $\pm 0,01$ m/s. The measured velocity shall be adjusted considering all factors which may affect the impactor between the point of measurement and the point of impact, in order to determine the velocity of the impactor at the time of impact.
- 4.7. The acceleration time histories shall be recorded, and HIC shall be calculated. The first point of contact on the front structure of the vehicle shall be recorded. Recording of test results shall be in accordance with ISO 6487:2002.

PART V

TEST IMPACTORS**1. Lower Legform impactor**

- 1.1. The lower legform impactor shall consist of two foam-covered rigid segments, representing femur (upper leg) and tibia (lower leg), joined by a deformable, simulated knee joint. The overall length of the impactor shall be 926 ± 5 mm and comply with Figure 1.

The length of the femur and tibia shall be 432 mm and 494 mm from the centre of the knee respectively.

The centre of gravity of the femur and tibia shall be 217 ± 10 mm and 233 ± 10 mm from the centre of the knee respectively.

Brackets, pulleys, etc. attached to the impactor for the purpose of launching it, may extend the dimensions shown in Figure 1, with the exception of the location of the centre of gravity.

- 1.2. The diameter of the femur and tibia shall be 70 ± 1 mm and both shall be covered by foam 'flesh' and skin. The foam flesh shall be 25 mm thick Confor™ foam type CF-45 or equivalent. The skin shall be made of neoprene foam, faced with 0,5 mm thick nylon cloth both sides, with an overall thickness of 6 mm.
- 1.3. The mass of the femur and tibia shall be $8,6 \pm 0,1$ kg and $4,8 \pm 0,1$ kg respectively, and the total mass of the impactor shall be $13,4 \pm 0,2$ kg.
- 1.4. The moment of inertia of the femur and tibia, about a horizontal axis through the respective centre of gravity and perpendicular to the direction of impact, shall be $0,127 \pm 0,010$ kgm² and $0,120 \pm 0,010$ kgm² respectively.
- 1.5. Transducers shall be fitted to measure knee bending angle and knee shearing displacement. A uniaxial accelerometer shall be mounted on the non-impacted side of the tibia, 66 ± 5 mm below centre of the knee, with its sensitive axis in the direction of impact.
- 1.6. A damper shall be fitted to the shear displacement system and may be mounted at any point on the rear face of the impactor or internally. The damper properties shall be such that the impactor meets both the static and dynamic shear displacement requirements and prevents excessive vibrations of the shear displacement system.
- 1.7. The instrumentation response value channel frequency class (CFC), as defined in ISO 6487:2002, shall be 180 for all transducers. The channel amplitude class (CAC) response values, as defined in ISO 6487:2002, shall be 50° for the knee bending angle, 10 mm for the shearing displacement and 500 g for the acceleration. This does not require that the impactor itself be able to physically bend and shear to these angles and displacements.
- 1.8. The impactor shall meet the certification requirements specified in Section 2 of Appendix I, and shall be fitted with deformable knee elements from the same batch as those used in the certification tests.
 - 1.8.1. For each test the impactor shall be fitted with new foam cut from one of up to four consecutive sheets of Confor™ foam flesh material, or equivalent, produced from the same batch of manufacture (cut from one block or bun of foam), provided that foam from one of these sheets was used in the dynamic certification test and the individual weights of these sheets are within ± 2 % of the weight of the sheet used in the certification test.
 - 1.8.2. The test impactor or at least the foam flesh shall be stored during a period of at least four hours in a controlled storage area with a stabilised humidity of 35 percent \pm 15 percent and a stabilised temperature of 20 ± 4 °C prior to impactor removal for calibration. After removal from the storage the impactor shall not be subjected to conditions other than those existing in the test area.
 - 1.8.3. Each test shall be completed within two hours of when the impactor to be used is removed from the controlled storage area.
- 1.9. The certified impactor may be used for a maximum of 20 impacts before re-certification. With each test new plastically deformable knee elements shall be used.

The impactor shall also be re-certified if more than one year has elapsed since the previous certification or if any impactor transducer output, in any impact, has exceeded the specified CAC or has reached the mechanical limits of the leg impactor deformation capability.

Figure 1

Lower legform impactor with skin and foam covering

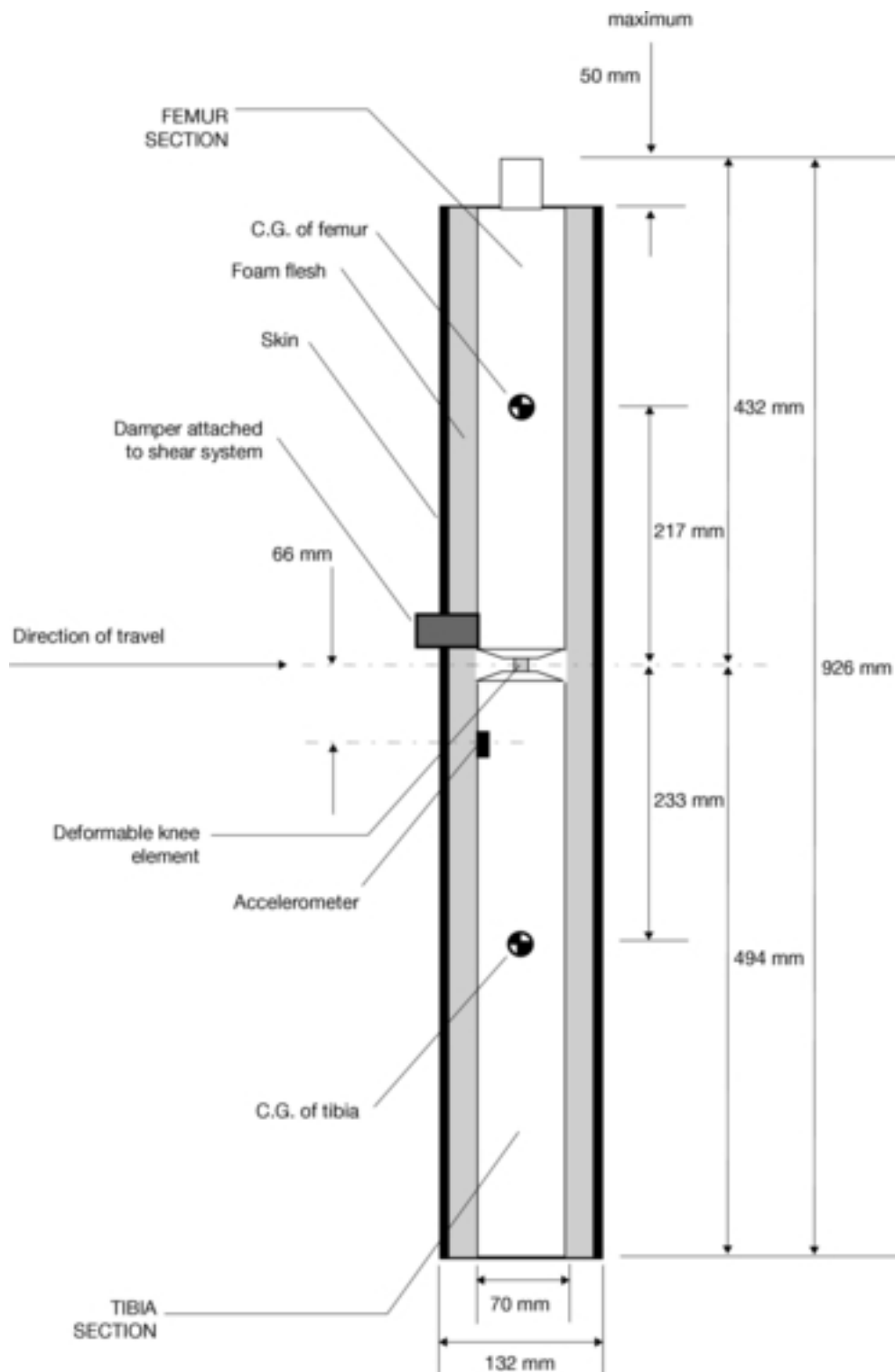

2. Upper legform impactor

- 2.1. The upper legform impactor shall be rigid, foam-covered at the impact side, and 350 ± 5 mm long and comply with Figure 2.

The length between the load transducer centre lines shall be 310 ± 1 mm and the front member diameter shall be 50 ± 1 mm.

- 2.2. The torque limiting joint shall be set so that the longitudinal axis of the front member is perpendicular to the axis of the guidance system, with a tolerance of $\pm 2^\circ$, with the joint friction torque set to 675 ± 25 Nm.
- 2.3. The centre of gravity of those parts of the impactor which are effectively forward of the torque limiting joint, including any weights fitted, shall lie on the longitudinal centre line of the impactor, with a tolerance of ± 10 mm.
- 2.4. The total mass of the upper legform impactor, including those propulsion and guidance components which are effectively part of the impactor, shall be $9,5 \text{ kg} \pm 0,1 \text{ kg}$.

The total mass of the front member and other components in front of the load transducer assemblies, together with those parts of the load transducer assemblies in front of the active elements, but excluding the foam and skin, shall be $1,95 \pm 0,05 \text{ kg}$.

- 2.5. Two load transducers shall be fitted to measure the individual forces applied at either end of the upper legform impactor front member.
- 2.6. Three strain gauges shall be located on the impactor to measure the bending moments of the front member, as shown in Figure 2, each using a separate channel. The two outer strain gauges are located 50 ± 1 mm from the impactor's symmetrical axis. The middle strain gauge is located on the symmetrical axis with a ± 1 mm tolerance.
- 2.7. The instrumentation response value channel frequency class (CFC), as defined in ISO 6487:2002, shall be 180 for all transducers. The channel amplitude class (CAC) response values, as defined in ISO 6487:2002, shall be 10 kN for the force transducers and 1000 Nm for the bending moment measurements.
- 2.8. The upper legform impactor shall meet the certification requirements specified in Section 3 of Appendix I, and shall be fitted with foam cut from the sheet of material used for the dynamic certification test.
- 2.9. For each test the foam shall be two new sheets of 25 mm thick ConforTM foam type CF-45 or equivalent. The skin shall be a 1,5 mm thick fibre reinforced rubber sheet. The foam and rubber skin together shall weigh $0,6 \pm 0,1 \text{ kg}$ (this excludes any reinforcement, mountings, etc. which are used to attach the rear edges of the rubber skin to the rear member).

The foam and rubber skin shall be folded back towards the rear, with the rubber skin attached via spacers to the rear member so that the sides of the rubber skin are held parallel.

The foam shall be of such a size and shape that an adequate gap is maintained between the foam and components behind the front member, to avoid significant load paths between the foam and these components.

- 2.9.1. The test impactor or at least the foam flesh shall be stored during a period of at least four hours in a controlled storage area with a stabilised humidity of 35 percent ± 15 percent and a stabilised temperature of $20 \pm 4^\circ\text{C}$ prior to impactor removal for calibration. After removal from the storage the impactor shall not be subjected to conditions other than those existing in the test area.
- 2.9.2. Each test shall be completed within two hours of when the impactor to be used is removed from the controlled storage area.
- 2.10. The certified impactor may be used for a maximum of 20 impacts before re-certification (this limit does not apply to propulsion or guidance components).

The impactor shall also be re-certified if more than one year has elapsed since the previous certification or if any impactor transducer output, in any impact, has exceeded the specified CAC.

Figure 2

Upper legform impactor

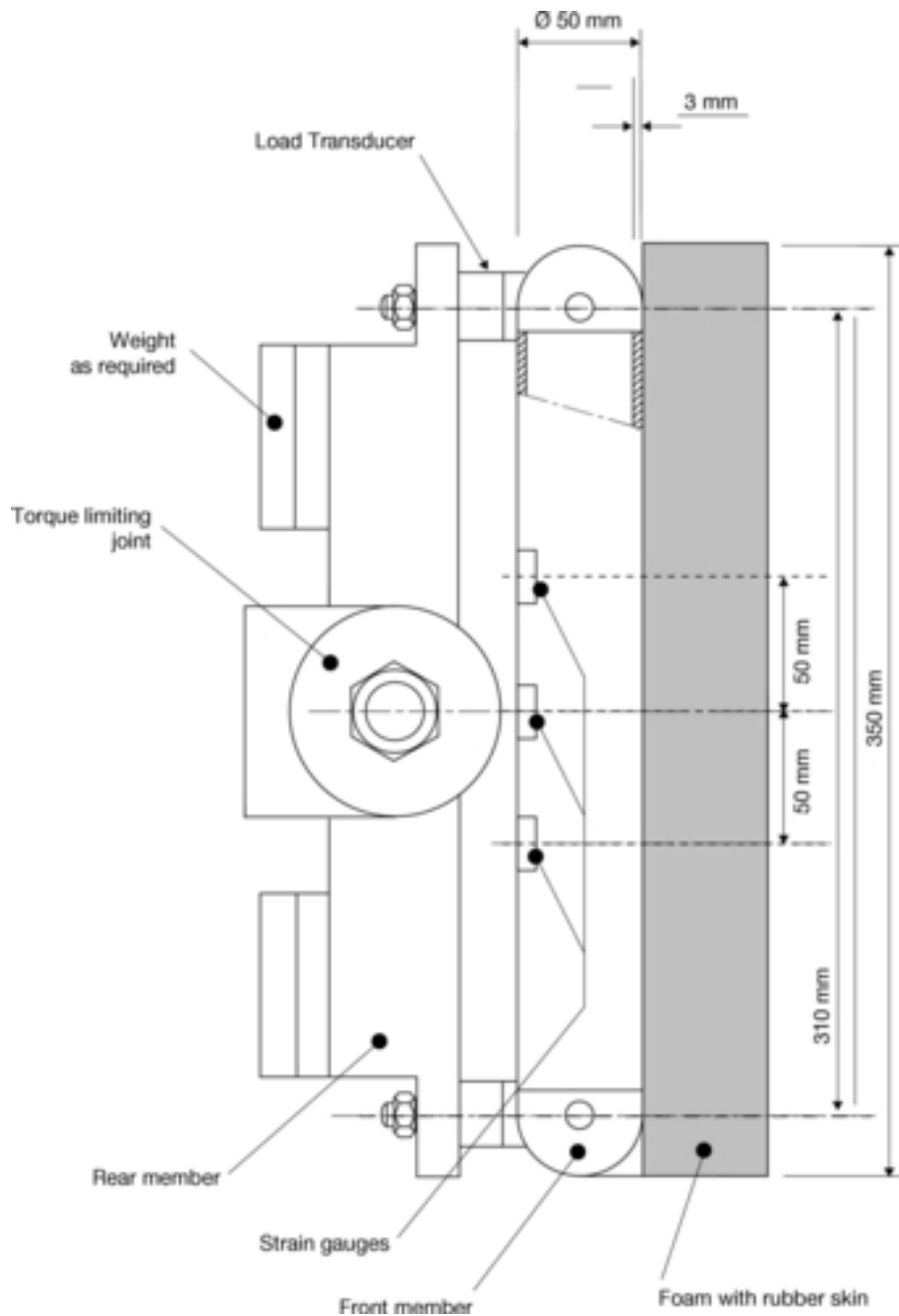

3. Child/Small Adult headform impactor

- 3.1. The child/small adult headform impactor shall be a rigid sphere, made of aluminium, fitted with a synthetic skin and shall comply with Figure 3 of this Part. The diameter shall be 165 ± 1 mm as shown in the figure. The total impactor mass, including instrumentation, shall be $3,5 \pm 0,07$ kg.
- 3.2. The sphere shall be covered with a $14,0 \pm 0,5$ mm thick synthetic skin, which shall cover at least half of the sphere.
- 3.3. The centre of gravity of the impactor, including instrumentation, shall be located in the centre of the sphere with a tolerance of ± 2 mm. The moment of inertia about an axis through the centre of gravity and perpendicular to the direction of impact shall be in the range of 0,008 to 0,012 kgm².

- 3.4. A recess in the sphere shall allow for mounting one triaxial or three uniaxial accelerometers within ± 10 mm seismic mass location tolerance from the centre of the sphere for the measurement axis, and ± 1 mm seismic mass location tolerance from the centre of the sphere for the perpendicular direction to the measurement axis. The accelerometers shall be positioned according points 3.4.1 and 3.4.2.
- 3.4.1. If three uniaxial accelerometers are used, one of the accelerometers shall have its sensitive axis perpendicular to the mounting face A (Figure 3) and its seismic mass shall be positioned within a cylindrical tolerance field of 1 mm radius and 20 mm length. The centre line of the tolerance field shall run perpendicular to the mounting face and its mid point shall coincide with the centre of the sphere of the headform impactor.
- 3.4.2. The remaining accelerometers shall have their sensitive axes perpendicular to each other and parallel to the mounting face A and their seismic mass shall be positioned within a spherical tolerance field of 10 mm radius. The centre of the tolerance field shall coincide with the centre of the sphere of the headform impactor.
- 3.5. The instrumentation response value channel frequency class (CFC), as defined in ISO 6487:2002, shall be 1 000. The channel amplitude class (CAC) response value, as defined in ISO 6487:2002, shall be 500 g for the acceleration.
- 3.6. The impactor shall meet the performance requirements specified in Section 4 of Appendix I. The certified impactor may be used for a maximum of 20 impacts before re-certification. The impactor shall be re-certified if more than one year has elapsed since the previous certification or if the transducer output, in any impact, has exceeded the specified CAC.
- 3.7. The first natural frequency of the impactor shall be over 5 000 Hz.

Figure 3

Child/Small Adult headform impactor (dimensions in mm)

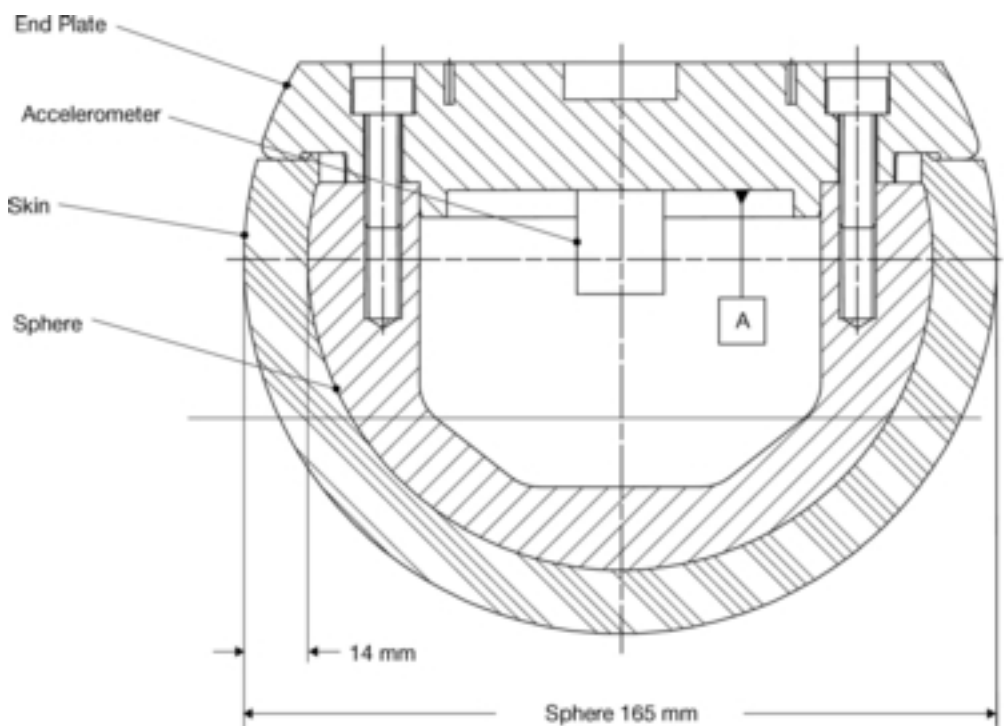

4. Adult headform impactor

- 4.1. The adult headform impactor shall be a rigid sphere, made of aluminium, fitted with a synthetic skin and shall comply with Figure 4. The diameter shall be 165 ± 1 mm as shown in the figure.
- 4.1.1. For the purposes of testing for compliance with Part II, Chapter VI the total impactor mass, including instrumentation, shall be $4,8 \pm 0,1$ kg.
- 4.1.2. For the purposes of testing for compliance with Part II, Chapter VII the total impactor mass, including instrumentation, shall be $4,5 \pm 0,1$ kg.
- 4.2. The sphere shall be covered with a $14,0 \pm 0,5$ mm thick synthetic skin, which shall cover at least half of the sphere.

- 4.3. The centre of gravity of the impactor, including instrumentation, shall be located in the centre of the sphere with a tolerance of ± 5 mm. The moment of inertia about an axis through the centre of gravity and perpendicular to the direction of impact shall be in the range 0,010 to 0,013 kgm^2 .
- 4.4. A recess in the sphere shall allow for mounting one triaxial or three uniaxial accelerometers within ± 10 mm seismic mass location tolerance from the centre of the sphere for the measurement axis, and ± 1 mm seismic mass location tolerance from the centre of the sphere for the perpendicular direction to the measurement axis. The accelerometers shall be positioned in accordance with points 4.4.1 and 4.4.2.
- 4.4.1. If three uniaxial accelerometers are used, one of the accelerometers shall have its sensitive axis perpendicular to the mounting face A (Figure 4) and its seismic mass shall be positioned within a cylindrical tolerance field of 1 mm radius and 20 mm length. The centre line of the tolerance field shall run perpendicular to the mounting face and its mid-point shall coincide with the centre of the sphere of the headform impactor.
- 4.4.2. The remaining accelerometers shall have their sensitive axes perpendicular to each other and parallel to the mounting face A and their seismic mass shall be positioned within a spherical tolerance field of 10 mm radius. The centre of the tolerance field shall coincide with the centre of the sphere of the headform impactor.
- 4.5. The instrumentation response value channel frequency class (CFC), as defined in ISO 6487:2002, shall be 1 000. The channel amplitude class (CAC) response value, as defined in ISO 6487:2002, shall be 500 g for the acceleration.
- 4.6. The impactor shall meet the certification requirements specified in Section 4 of Appendix I. The certified impactor may be used for a maximum of 20 impacts before re-certification. The impactor shall be re-certified if more than one year has elapsed since the previous certification or if the transducer output, in any impact, has exceeded the specified CAC.
- 4.7. The first natural frequency of the impactor shall be over 5 000 Hz.

Figure 4

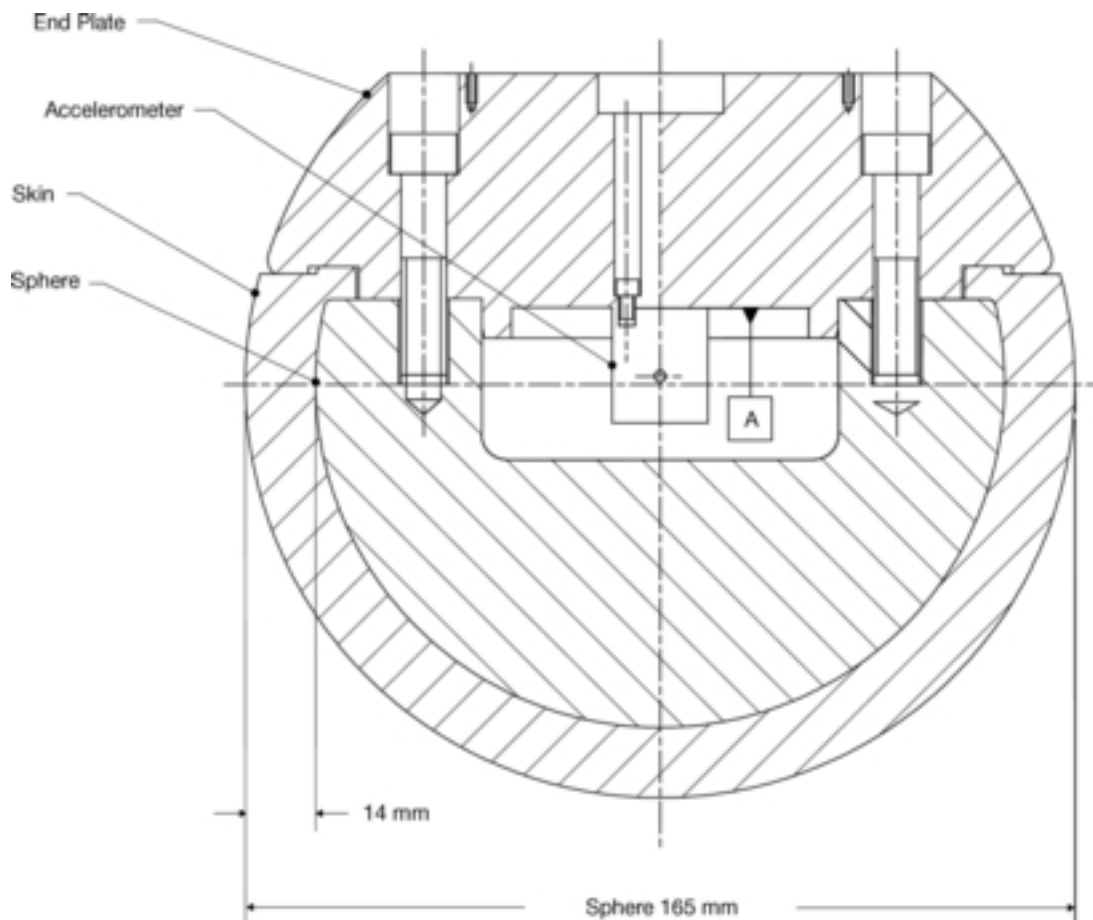
Adult headform impactor (dimensions in mm)

*Appendix I***Certification of Impactors****1. Certification requirements**

- 1.1. The impactors that are used in the tests detailed in Part II and Part IV are required to comply with appropriate performance requirements.

The requirements for the lower legform impactor are specified in Section 2; the upper legform impactor requirements are specified in Section 3 and the adult, child and child/small adult headform impactor requirements are specified in Section 4.

2. Lower legform impactor**2.1. Static tests**

- 2.1.1. The lower legform impactor shall meet the requirements specified in point 2.1.2 when tested as specified in point 2.1.4 and the impactor shall meet the requirements specified in point 2.1.3 when tested as specified in point 2.1.5.

For both tests the impactor shall have the intended orientation about its longitudinal axis, for the correct operation of its knee joint, with a tolerance of $\pm 2^\circ$.

The stabilised temperature of the impactor during certification shall be $20 \pm 2^\circ\text{C}$.

The CAC response values, as defined in ISO 6487:2002, shall be 50° for the knee bending angle and 500 N for the applied force when the impactor is loaded in bending in accordance with point 2.1.4, and 10 mm for the shearing displacement and 10 kN for the applied force when the impactor is loaded in shearing in accordance with point 2.1.5. For both tests low-pass filtering at an appropriate frequency is permitted, to remove higher frequency noise without significantly affecting the measurement of the response of the impactor.

- 2.1.2. When the impactor is loaded in bending in accordance with point 2.1.4 the applied force/bending angle response shall be within the limits shown in Figure 1. Also, the energy taken to generate $15,0^\circ$ of bending shall be $100 \pm 7\text{ J}$.

- 2.1.3. When the impactor is loaded in shearing in accordance with point 2.1.5 the applied force/shearing displacement response shall be within the limits shown in Figure 2.

- 2.1.4. The legform impactor, without foam covering and skin, shall be mounted with the tibia firmly clamped to a fixed horizontal surface and a metal tube connected firmly to the femur, as shown in Figure 3. The rotational axis of the impactor knee joint shall be vertical. To avoid friction errors, no support shall be provided to the femur section or the metal tube. The bending moment applied at the centre of the knee joint, due to the weight of the metal tube and other components (excluding the legform itself), shall not exceed 25 Nm.

A horizontal normal force shall be applied to the metal tube at a distance of $2,0 \pm 0,01\text{ m}$ from the centre of the knee joint and the resulting angle of knee deflection shall be recorded. The load shall be increased such that the rate of increase of the angle of deflection of the knee is between 1 and $10^\circ/\text{s}$ until the angle of deflection of the knee is in excess of 22° . Brief excursions from these limits due, for instance, to the use of a hand-pump shall be permitted.

The energy is calculated by integrating the force with respect to the bending angle in radians, and multiplying by the lever length of $2,0 \pm 0,01\text{ m}$.

- 2.1.5. The impactor, without foam covering and skin, shall be mounted with the tibia firmly clamped to a fixed horizontal surface and a metal tube connected firmly to the femur and restrained at 2,0 m from the centre of the knee joint, as shown in Figure 4.

A horizontal normal force shall be applied to the femur at a distance of 50 mm from the centre of the knee joint and the resulting knee shearing displacement shall be recorded. The load shall be increased such that the rate of increase of the shearing displacement of the knee is between 0,1 and 20 mm/s until the shearing displacement of the knee is in excess of 7,0 mm or the load is in excess of 6,0 kN. Brief excursions from these limits due, for instance, to the use of a hand-pump shall be permitted.

2.2. *Dynamic tests*

2.2.1. The lower legform impactor shall meet the requirements specified in point 2.2.2 when tested as specified in point 2.2.4.

2.2.1.1. The foam flesh for the test impactor shall be stored for a period of at least four hours in a controlled storage area with a stabilised humidity of 35 ± 10 percent and a stabilised temperature of 20 ± 2 °C prior to impactor removal for calibration. The test impactor itself shall have a temperature of 20 ± 2 °C at the time of impact. The temperature tolerances for the test impactor shall apply at a relative humidity of 40 ± 30 percent after a soak period of at least four hours prior to their application in a test.

2.2.1.2. The test facility used for the calibration test shall have a stabilised humidity of 40 ± 30 percent and a stabilised temperature of 20 ± 4 °C during calibration.

2.2.1.3. Each calibration shall be completed within two hours of when the impactor to be calibrated is removed from the controlled storage area.

2.2.1.4. The relative humidity and temperature of the calibration area shall be measured at the time of calibration and recorded in the calibration report.

2.2.2. When the impactor is impacted by a linearly guided certification impactor, as specified in point 2.2.4, the maximum upper tibia acceleration shall be not less than 120 g and not more than 250 g. The maximum bending angle shall be not less than $6,2^\circ$ and not more than $8,2^\circ$. The maximum shearing displacement shall be not less than 3,5 mm and not more than 6,0 mm.

For all these values the readings used shall be from the initial impact with the certification impactor and not from the arresting phase. Any system used to arrest the impactor or certification impactor shall be so arranged that the arresting phase does not overlap in time with the initial impact. The arresting system shall not cause the transducer outputs to exceed the specified CAC.

2.2.3. The instrumentation response value CFC, as defined in ISO 6487:2002, shall be 180 for all transducers. The CAC response values, as defined in ISO 6487:2002, shall be 50° for the knee bending angle, 10 mm for the shearing displacement and 500 g for the acceleration. This does not require that the impactor itself be able to physically bend and shear to these angles and displacements.

2.2.4. *Test procedure*

2.2.4.1. The impactor, including foam covering and skin, shall be suspended horizontally by three wire ropes of $1,5 \pm 0,2$ mm diameter and of 2,0 m minimum length, as shown in Figure 5a. It shall be suspended with its longitudinal axis horizontal, with a tolerance of $\pm 0,5^\circ$, and perpendicular to the direction of the certification impactor motion, with a tolerance of $\pm 2^\circ$. The impactor shall have the intended orientation about its longitudinal axis, for the correct operation of its knee joint, with a tolerance of $\pm 2^\circ$. The impactor shall meet the requirements of point 3.4.1.1 Chapter II of Part II with the attachment bracket(s) for the wire ropes fitted.

2.2.4.2. The certification impactor shall have a mass of $9,0 \pm 0,05$ kg, this mass includes those propulsion and guidance components which are effectively part of the certification impactor during impact. The dimensions of the face of the certification impactor shall be as specified in Figure 5b. The face of the certification impactor shall be made of aluminium, with an outer surface finish of better than 2,0 micrometers.

The guidance system shall be fitted with low friction guides, insensitive to off-axis loading, that allow the impactor to move only in the specified direction of impact, when in contact with the lower legform impactor. The guides shall prevent motion in other directions including rotation about any axis.

2.2.4.3. The impactor shall be certified with previously unused foam.

2.2.4.4. The impactor foam shall not be excessively handled or deformed before, during or after fitting.

2.2.4.5. The certification impactor shall be propelled horizontally at a velocity of $7,5 \pm 0,1$ m/s into the stationary impactor as shown in Figure 5a. The certification impactor shall be positioned so that its centreline aligns with a position on the tibia centreline of 50 mm from the centre of the knee, with tolerances of ± 3 mm laterally and ± 3 mm vertically.

3. Upper legform impactor

3.1. The upper legform impactor shall meet the requirements specified in point 3.2 when tested as specified in point 3.3.

3.1.1. The foam flesh for the test impactor shall be stored for a period of at least four hours in a controlled storage area with a stabilised humidity of 35 ± 10 percent and a stabilised temperature of 20 ± 2 °C prior to impactor removal for calibration. The test impactor itself shall have a temperature of 20 ± 2 °C at the time of impact. The temperature tolerances for the test impactor shall apply at a relative humidity of 40 ± 30 percent after a soak period of at least four hours prior to their application in a test.

3.1.2. The test facility used for the calibration test shall have a stabilised humidity of 40 ± 30 percent and a stabilised temperature of 20 ± 4 °C during calibration.

3.1.3. Each calibration shall be completed within two hours of when the impactor to be calibrated is removed from the controlled storage area.

3.1.4. The relative humidity and temperature of the calibration area shall be measured at the time of calibration and recorded in the calibration report.

3.2. Requirements

3.2.1. When the impactor is propelled into a stationary cylindrical pendulum the peak force measured in each load transducer shall be not less 1,20 kN and not more than 1,55 kN and the difference between the peak forces measured in the top and bottom load transducers shall not be more than 0,10 kN. Also, the peak bending moment measured by the strain gauges shall not be less than 190 Nm and not more than 250 Nm on the centre position and not less than 160 Nm and not more than 220 Nm for the outer positions. The difference between the upper and lower peak bending moments shall not be more than 20 Nm.

For all these values the readings used shall be from the initial impact with the pendulum and not from the arresting phase. Any system used to arrest the impactor or pendulum shall be so arranged that the arresting phase does not overlap in time with the initial impact. The arresting system shall not cause the transducer outputs to exceed the specified CAC.

3.2.2. The instrumentation response value CFC, as defined in ISO 6487:2002, shall be 180 for all transducers. The CAC response values, as defined in ISO 6487:2002, shall be 10 kN for the force transducers and 1 000 Nm for the bending moment measurements.

3.3. Test procedure

3.3.1. The impactor shall be mounted to the propulsion and guidance system, by a torque limiting joint. The torque limiting joint shall be set so that the longitudinal axis of the front member is perpendicular to the axis of the guidance system, with a tolerance of $\pm 2^\circ$, with the joint friction torque set to a minimum of 675 ± 25 Nm. The guidance system shall be fitted with low friction guides that allow the impactor to move only in the specified direction of impact, when in contact with the pendulum.

3.3.2. The impactor mass shall be adjusted to give a mass of $12 \pm 0,1$ kg, this mass includes those propulsion and guidance components which are effectively part of the impactor during impact.

3.3.3. The centre of gravity of those parts of the impactor which are effectively forward of the torque limiting joint, including the extra weights fitted, shall lie on the longitudinal centreline of the impactor, with a tolerance of ± 10 mm.

3.3.4. The impactor shall be certified with previously unused foam.

3.3.5. The impactor foam shall not be excessively handled or deformed before, during or after fitting.

- 3.3.6. The impactor with the front member vertical shall be propelled horizontally at a velocity of $7,1 \pm 0,1$ m/s into the stationary pendulum as shown in Figure 6.

The pendulum tube shall have a mass of $3 \pm 0,03$ kg, an outside diameter of $150 \text{ mm} + 1 \text{ mm} / - 4 \text{ mm}$ and a wall thickness of $3 \pm 0,15$ mm. Total pendulum tube length shall be 275 ± 25 mm. The pendulum tube shall be made from cold finished seamless steel (metal surface plating is permissible for protection from corrosion), with an outer surface finish of better than 2,0 micrometers. It shall be suspended on two wire ropes of $1,5 \pm 0,2$ mm diameter and of 2,0 m minimum length. The surface of the pendulum shall be clean and dry. The pendulum tube shall be positioned so that the longitudinal axis of the cylinder is perpendicular to the front member (i.e. level), with a tolerance of $\pm 2^\circ$, and to the direction of impactor motion, with a tolerance of $\pm 2^\circ$, and with the centre of the pendulum tube aligned with the centre of the impactor front member, with tolerances of ± 5 mm laterally and ± 5 mm vertically.

4. **Headform impactors**

4.1. *Performance criteria*

The headform impactors shall meet the requirements specified in Section 4.2 when tested as specified in Section 4.4.

4.2. *Requirements*

- 4.2.1. When the headform impactors are dropped from a height of 376 ± 1 mm in accordance with point 4.4. the peak resultant acceleration measured by one triaxial (or three uniaxial) accelerometer (accelerometers) in the headform impactor shall be:

- (a) for the child/small adult headform impactor not less than 245 g and not more than 300 g;
- (b) for the adult headform impactor not less than 225 g and not more than 275 g.

The acceleration time curves shall be uni-modal.

- 4.2.2. The instrumentation channel frequency class (CFC) response values and channel amplitude class (CAC) for each accelerometer shall be 1 000 Hz and 500g respectively as defined in ISO 6487:2002.

4.2.3. *Temperature conditions*

The headform impactors shall have a temperature of 20 ± 2 °C at the time of impact. The temperature tolerances shall apply at a relative humidity of 40 ± 30 percent after a soak period of at least four hours prior to their application in a test.

- 4.3. After complying with the certification test, each headform impactor can be used for a maximum of 20 impact tests.

4.4. *Test procedure*

- 4.4.1. The headform impactor shall be suspended from a drop rig as shown in Figure 7.

- 4.4.2. The headform impactor shall be dropped from the specified height by means that ensure instant release onto a rigidly supported flat horizontal steel plate, over 50 mm thick and over 300 x 300 mm square which has a clean dry surface and a surface finish of between 0,2 and 2,0 micrometers.

- 4.4.3. The headform impactor shall be dropped with the rear face of the impactor at the following angle from the vertical:

- (a) $50^\circ \pm 2^\circ$ for the child headform impactor;
- (b) $65^\circ \pm 2^\circ$ for the adult headform impactor;

- 4.4.4. The suspension of the headform impactor shall be such that it does not rotate during the fall.

- 4.4.5. The drop test shall be performed three times, with the headform impactor rotated 120° around its symmetrical axis between tests.

Figure 1

Force versus angle requirement in static lower legform impactor bending certification test

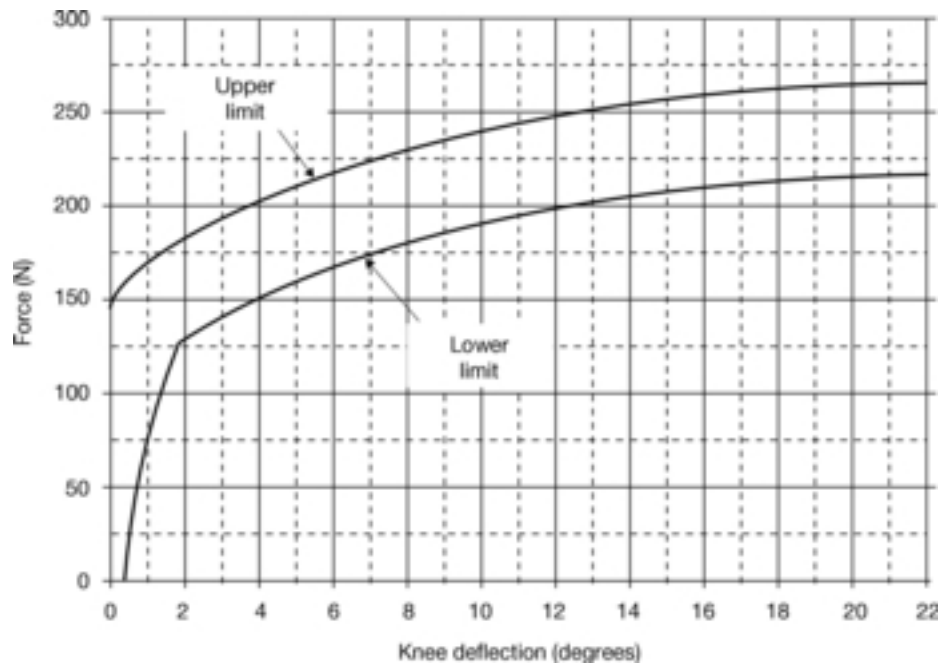

Figure 2

Force versus displacement requirement in static lower legform impactor shearing certification test

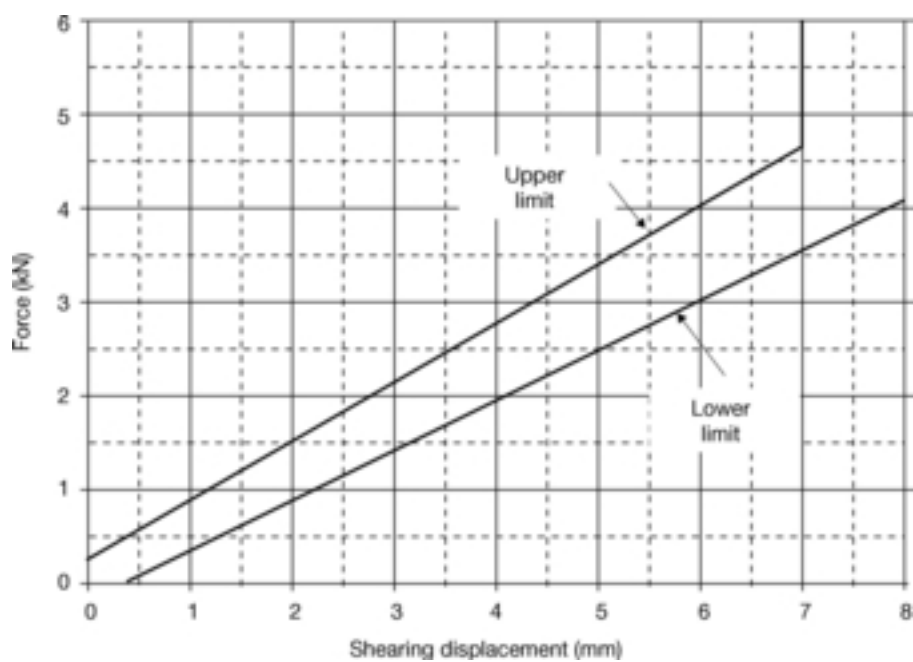

Figure 3

Top view of test set-up for static lower legform impactor bending certification test

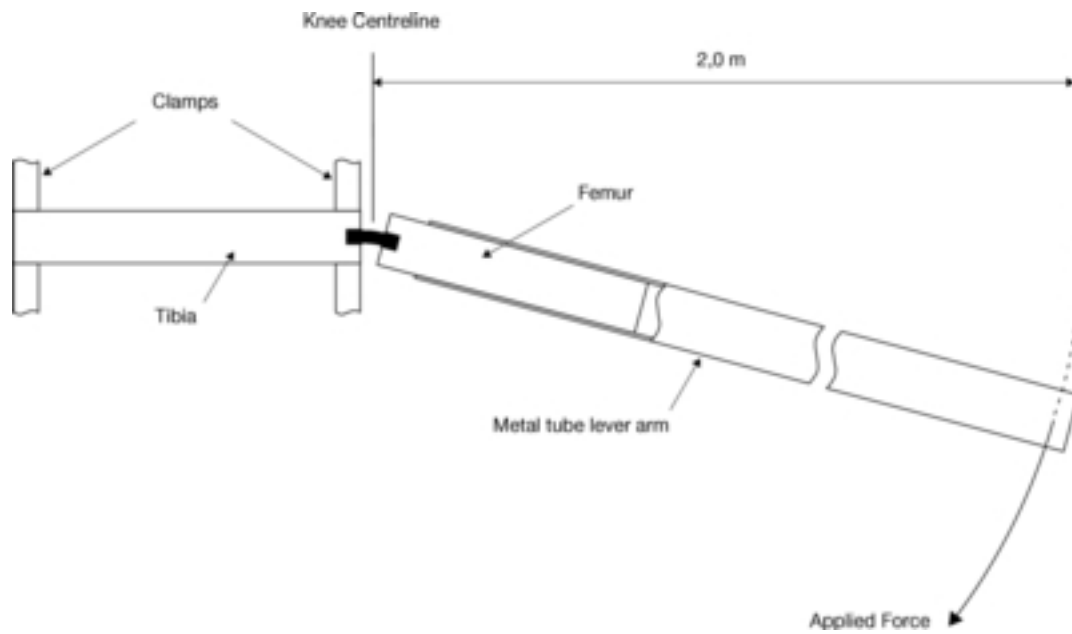

Figure 4

Top view of test set-up for static lower legform impactor shearing certification test

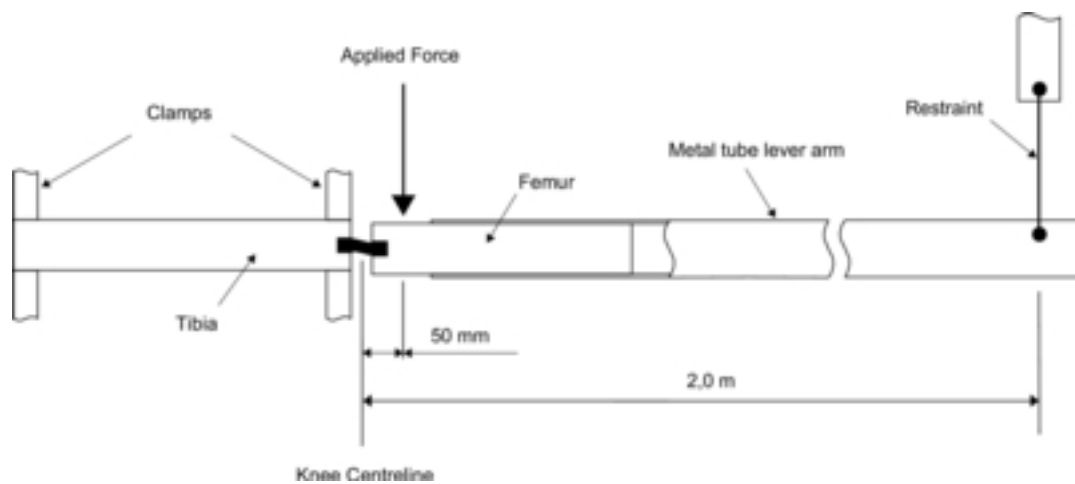

Figure 5a

Test set-up for dynamic lower legform impactor certification test (side view top diagram, view from above bottom diagram)

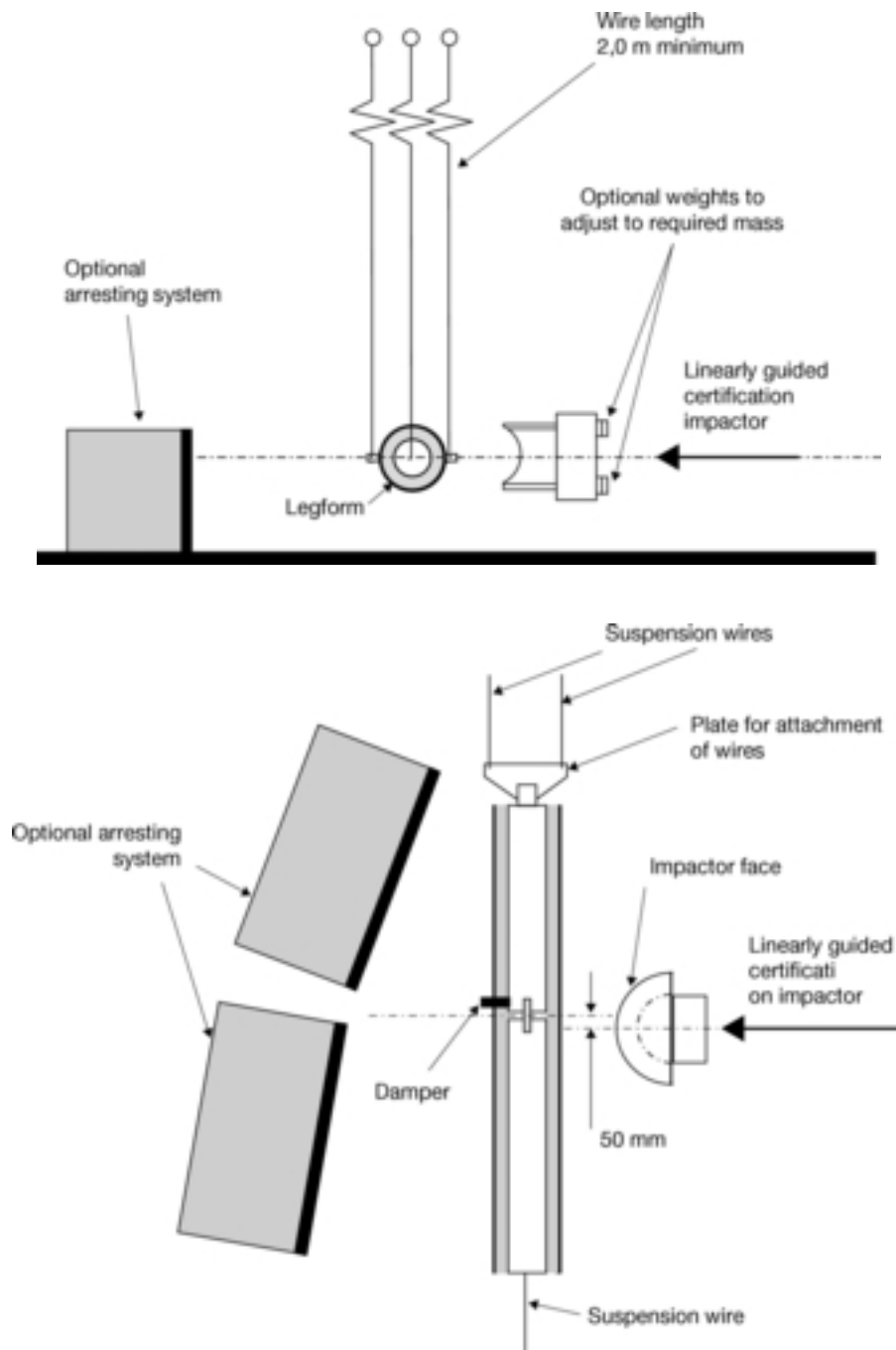
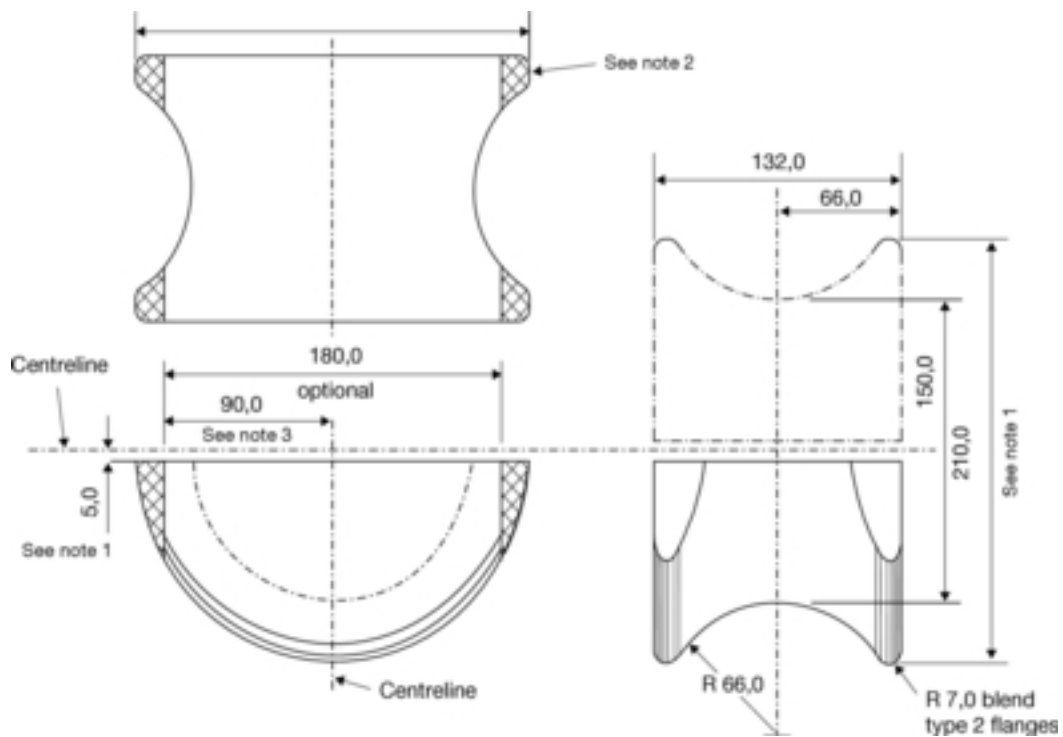

Figure 5b

Details of dynamic lower legform certification impactor face



Notes:

1. Saddle may be made as a complete diameter and cut as shown to make two components.
2. The shaded areas may be removed to give the alternative form shown.
3. Tolerance on all dimensions is $\pm 1,0$ mm.

Material: aluminium alloy.

Figure 6

Test set-up for dynamic upper legform impactor certification test

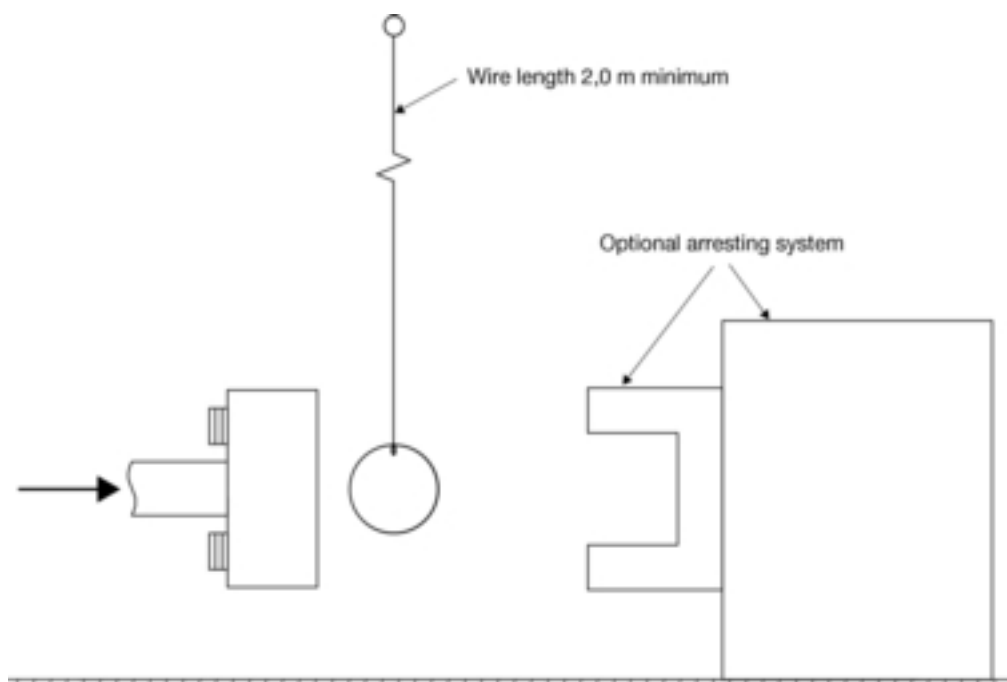

Figure 7

Test set-up for dynamic headform impactor certification test

