Changes to legislation: There are outstanding changes not yet made to Commission Regulation (EU) No 109/2011. Any changes that have already been made to the legislation appear in the content and are referenced with annotations. (See end of Document for details) [View outstanding changes](#)

Commission Regulation (EU) No 109/2011 of 27 January 2011 implementing Regulation (EC) No 661/2009 of the European Parliament and of the Council as regards type-approval requirements for certain categories of motor vehicles and their trailers as regards spray suppression systems (Text with EEA relevance)

Changes to legislation: There are outstanding changes not yet made to Commission Regulation (EU) No 109/2011. Any changes that have already been made to the legislation appear in the content and are referenced with annotations. (See end of Document for details) View outstanding changes

ANNEX VI

FIGURES

Figure 1a

Width (q) of mudguard (a) and position of valance (j)

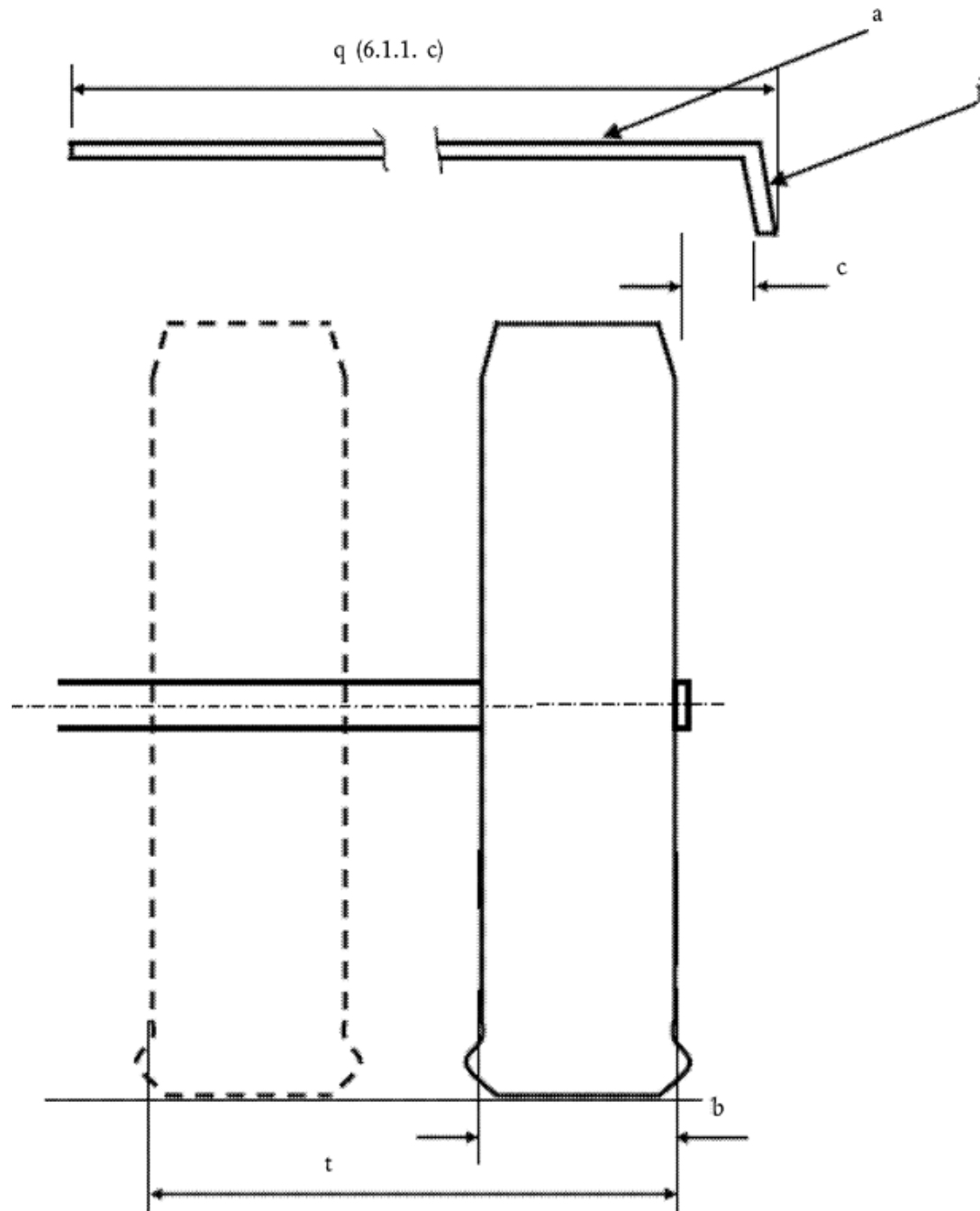

Figure 1b

Changes to legislation: There are outstanding changes not yet made to Commission Regulation (EU) No 109/2011. Any changes that have already been made to the legislation appear in the content and are referenced with annotations. (See end of Document for details) View outstanding changes

Example of measurement of the outer valance



Figure 2

Dimensions of mudguard and outer valance

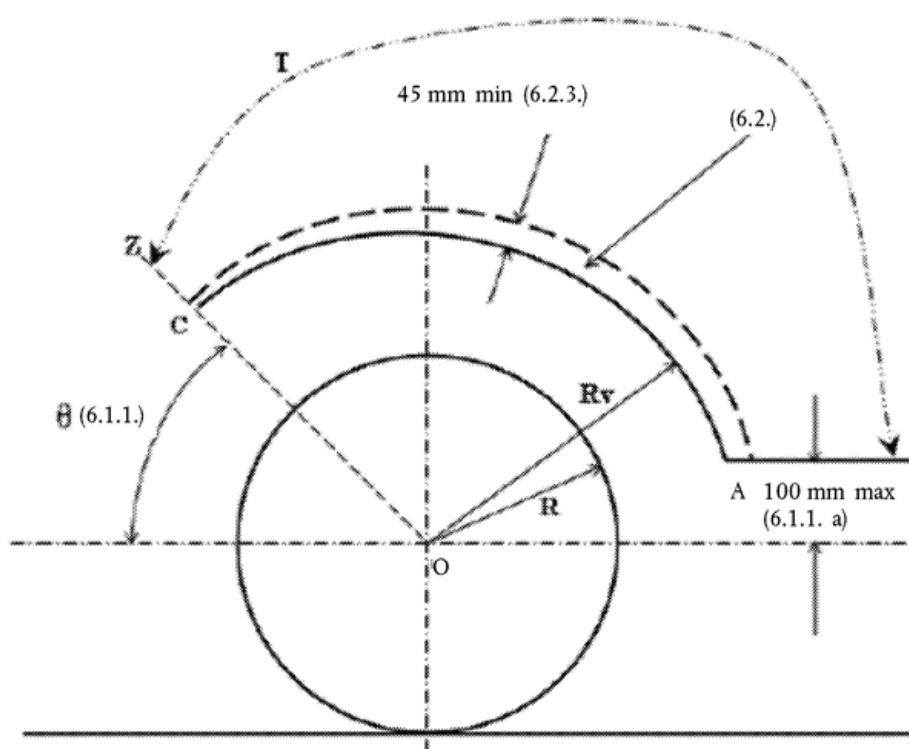

Figure 3

Changes to legislation: There are outstanding changes not yet made to Commission Regulation (EU) No 109/2011. Any changes that have already been made to the legislation appear in the content and are referenced with annotations. (See end of Document for details) View outstanding changes

Position of mudguard and rain flap

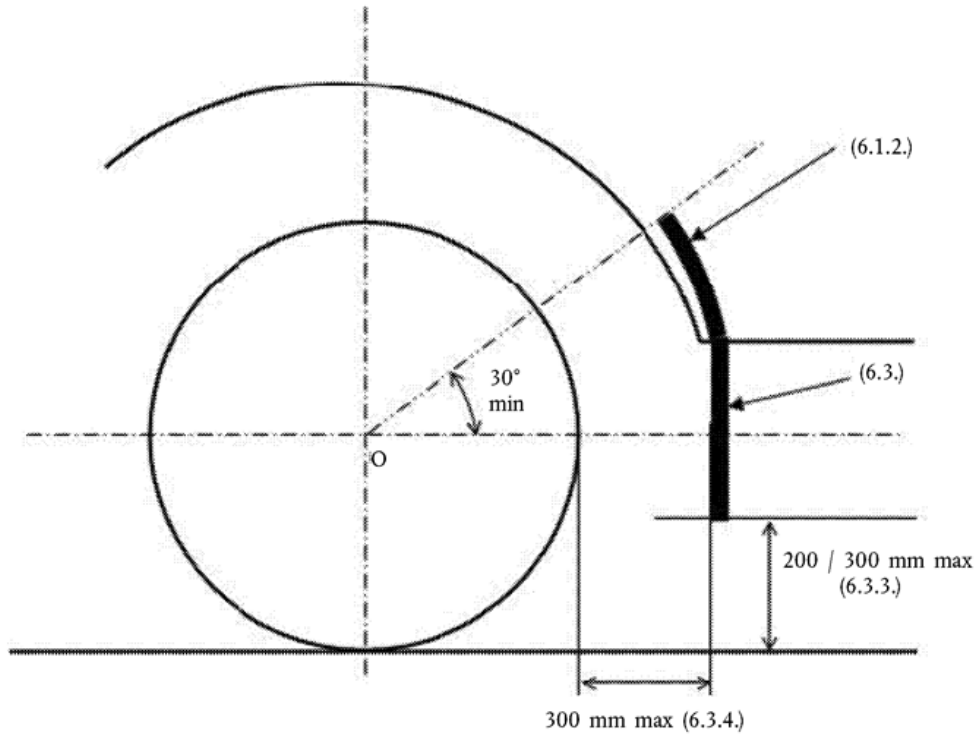

Figure 4

Diagram showing assembly of a spray-suppression system (mudguard, rain flap, outer valance) incorporating spray-suppression devices (energy absorbers) for multiple axles

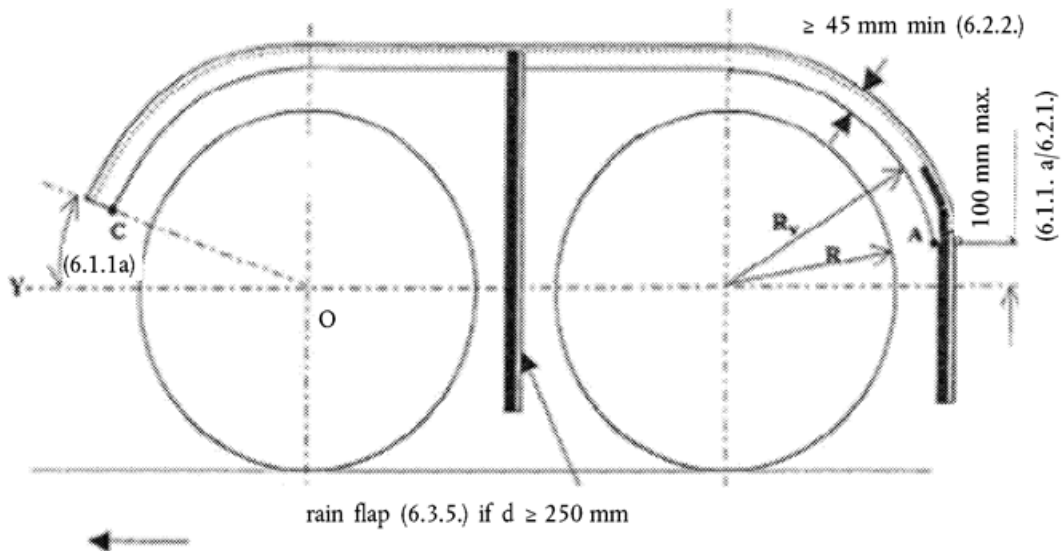

Figure 5

Changes to legislation: There are outstanding changes not yet made to Commission Regulation (EU) No 109/2011. Any changes that have already been made to the legislation appear in the content and are referenced with annotations. (See end of Document for details) View outstanding changes

Diagram showing assembly of a spray-suppression system incorporating spray-suppression devices (energy absorbers) for axles fitted with non-steered or self-steering wheels

(Annex IV – points 5.2 and 7)

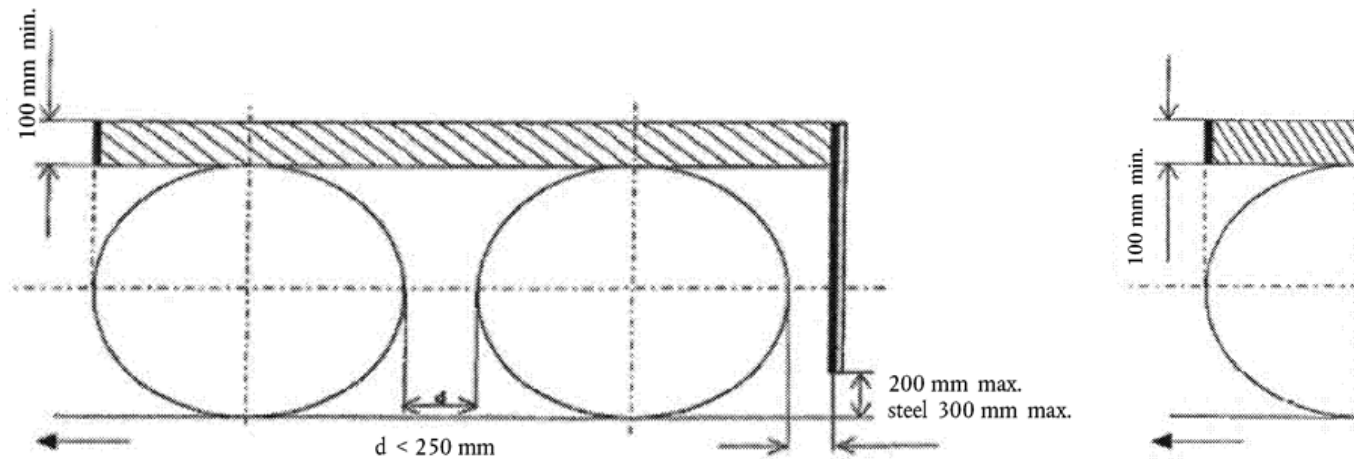

Figure 6

Diagram showing assembly of a spray-suppression system incorporating spray-suppression devices fitted with air/water separators for axles fitted with steered, self-steering or non-steered wheels

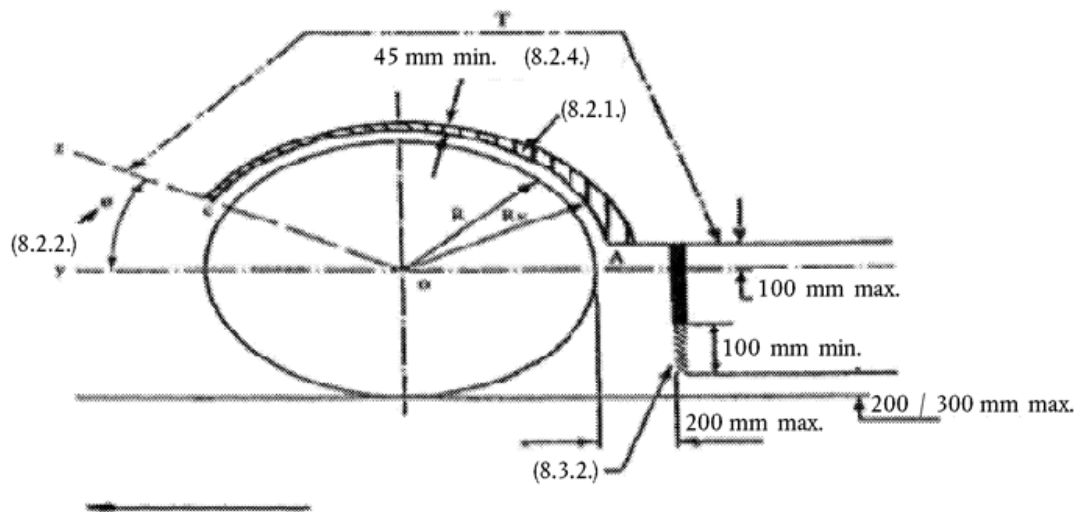

Figure 7

Changes to legislation: There are outstanding changes not yet made to Commission Regulation (EU) No 109/2011. Any changes that have already been made to the legislation appear in the content and are referenced with annotations. (See end of Document for details) View outstanding changes

Diagram showing assembly of a spray-suppression system incorporating spray-suppression devices (mudguard, rain flap, outer valance) for multiple axles where the distance between the tyres does not exceed 300 mm

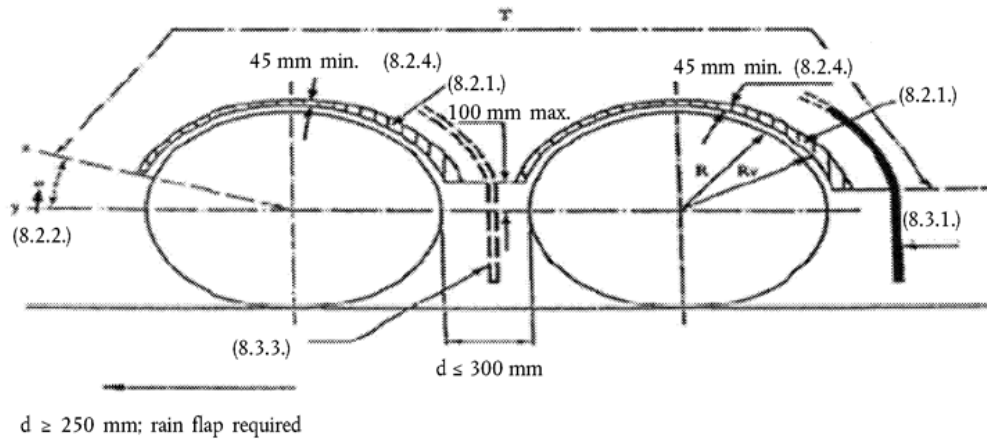

Figure 8

Test assembly for energy absorption spray-suppression devices

(Annex III, PART 2)

Changes to legislation: There are outstanding changes not yet made to Commission Regulation (EU) No 109/2011. Any changes that have already been made to the legislation appear in the content and are referenced with annotations. (See end of Document for details) View outstanding changes

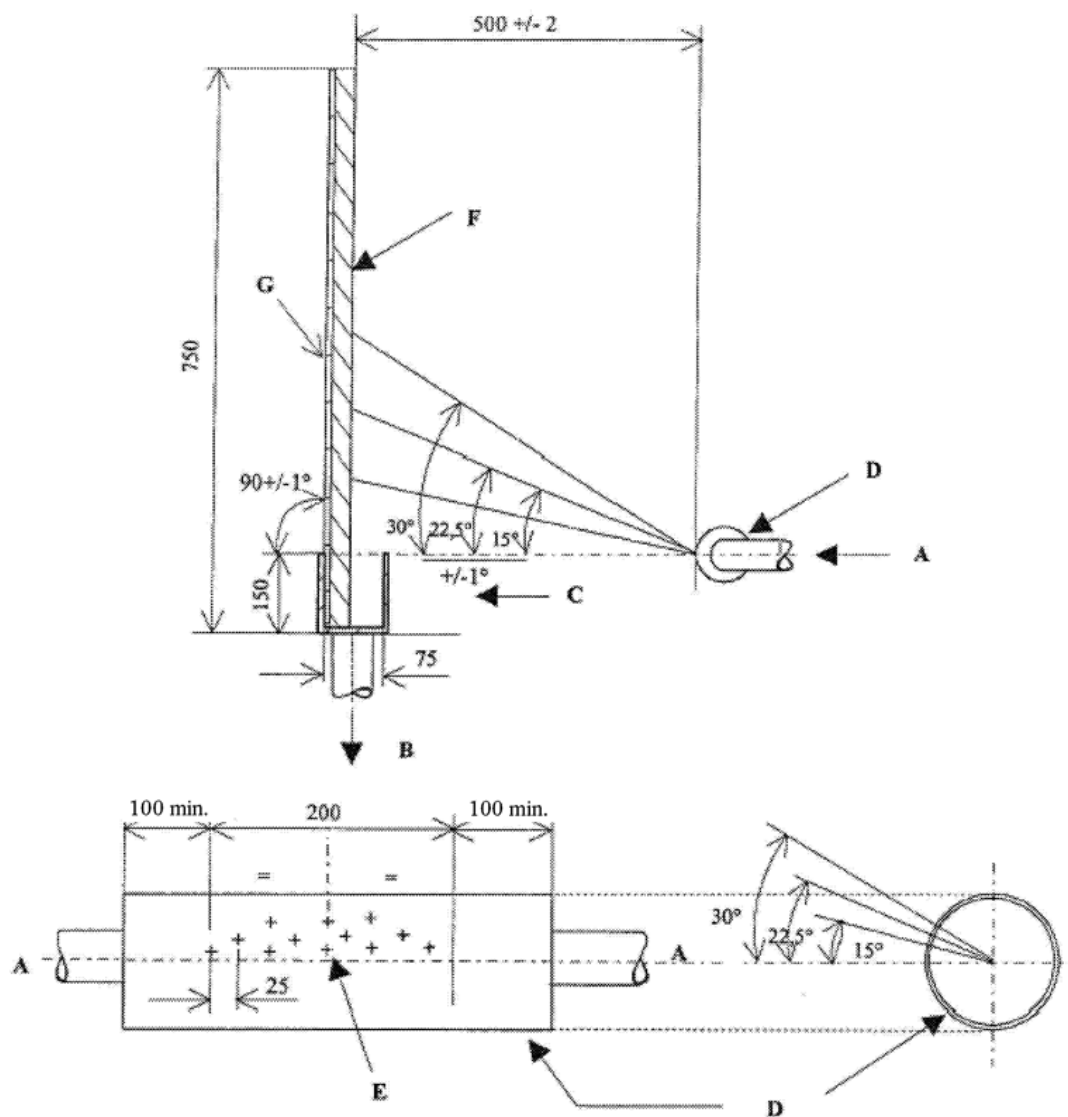
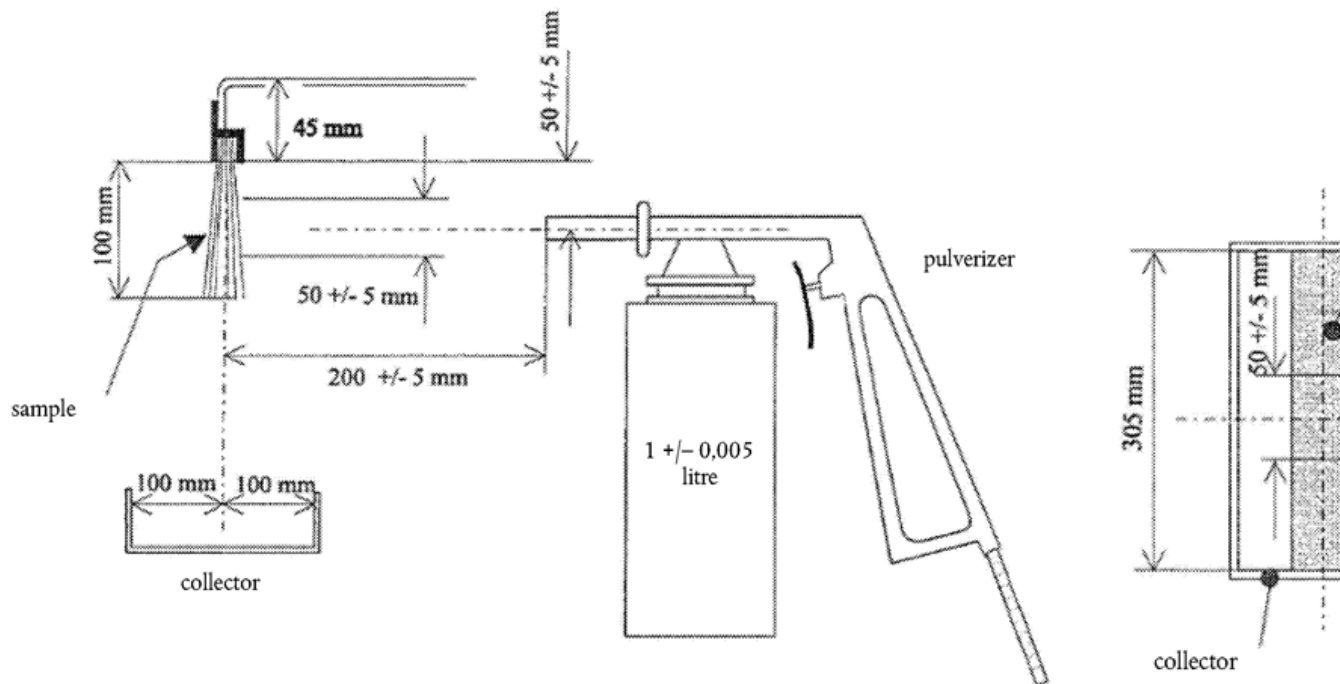

Figure 9

Test assembly for air/water separator spray-suppression devices

(Annex III, PART 3)

Changes to legislation: There are outstanding changes not yet made to Commission Regulation (EU) No 109/2011. Any changes that have already been made to the legislation appear in the content and are referenced with annotations. (See end of Document for details) View outstanding changes



Changes to legislation:

There are outstanding changes not yet made to Commission Regulation (EU) No 109/2011. Any changes that have already been made to the legislation appear in the content and are referenced with annotations.

[View outstanding changes](#)

Changes and effects yet to be applied to the whole legislation item and associated provisions

- Signature words omitted by [S.I. 2022/1273 reg. 63\(8\)](#)
- Annex 2 Pt. 2 s. 1 point 000.7 words substituted by [S.I. 2022/1273 reg. 63\(10\)\(c\)\(ii\)](#)
- Art. 2(11) words substituted by [S.I. 2022/1273 reg. 63\(3\)\(a\)](#)
- Art. 2(12) words substituted by [S.I. 2022/1273 reg. 63\(3\)\(b\)](#)
- Art. 2(13) words substituted by [S.I. 2022/1273 reg. 63\(3\)\(c\)](#)
- Art. 2(15) words substituted by [S.I. 2022/1273 reg. 63\(3\)\(d\)](#)
- Art. 2(16) words substituted by [S.I. 2022/1273 reg. 63\(3\)\(e\)](#)