

This text is meant purely as a documentation tool and has no legal effect. The Union's institutions do not assume any liability for its contents. The authentic versions of the relevant acts, including their preambles, are those published in the Official Journal of the European Union and available in EUR-Lex. Those official texts are directly accessible through the links embedded in this document

► **B**

COMMISSION REGULATION (EU) No 321/2013

of 13 March 2013

concerning the technical specification for interoperability relating to the subsystem ‘rolling stock — freight wagons’ of the rail system in the European Union and repealing Decision 2006/861/EC

(Text with EEA relevance)

(OJ L 104, 12.4.2013, p. 1)

Amended by:

		Official Journal		
		No	page	date
► <u>M1</u>	Commission Regulation (EU) No 1236/2013 of 2 December 2013	L 322	23	3.12.2013
► <u>M2</u>	Commission Regulation (EU) 2015/924 of 8 June 2015	L 150	10	17.6.2015
► <u>M3</u>	Commission Implementing Regulation (EU) 2019/776 of 16 May 2019	L 139I	108	27.5.2019

▼B**COMMISSION REGULATION (EU) No 321/2013****of 13 March 2013****concerning the technical specification for interoperability relating to the subsystem ‘rolling stock — freight wagons’ of the rail system in the European Union and repealing Decision 2006/861/EC****(Text with EEA relevance)***Article 1*

The technical specification for interoperability (TSI) relating to the ‘rolling stock — freight wagons’ subsystem of the entire European Union’s rail system, as set out in the Annex, is hereby adopted.

Article 2

1. The TSI shall apply to the ‘rolling stock — freight wagons’ subsystem as described in ►**M3** point 2.7 of Annex II to Directive (EU) 2016/797 of the European Parliament and of the Council⁽¹⁾ ◀.

2. The TSI shall apply to freight wagons with a maximum operating speed lower than or equal to 160 km/h and a maximum axle load lower than or equal to 25 t.

3. The TSI shall apply to freight wagons which are intended to be operated on one or more of the following nominal track gauges: 1 435 mm, 1 524 mm, 1 600 mm, and 1 668 mm. The TSI shall not apply to freight wagons operating mainly on the 1 520 mm track gauge, which may occasionally be operated on 1 524 mm track gauge.

Article 3

The TSI shall apply to all new freight wagon rolling stock of the European Union’s rail system, taking into account Section 7 of the Annex.

The TSI set out in the Annex shall also apply to existing freight wagon rolling stock:

▼M3

(a) when it is renewed and upgraded in accordance with section 7.2.2 of the Annex to this Regulation;

▼B

(b) with regard to specific provisions, such as the traceability of axles in point 4.2.3.6.4 and the maintenance plan in point 4.5.3;

⁽¹⁾ Directive (EU) 2016/797 of the European Parliament and of the Council of 11 May 2016 on the interoperability of the rail system within the European Union (OJ L 138, 26.5.2016, p. 44).

▼ M3

- (c) with regards to the marking ‘GE’ as depicted in point 5 of Appendix C of the Annex, wagons of the existing fleet which have been authorised in accordance with Commission Decision 2006/861/EC as amended by Decision 2009/107/EC or with Decision 2006/861/EC as amended by Decisions 2009/107/EC and 2012/464/EU and meeting the conditions set out in point 7.6.4 of Decision 2009/107/EC may receive this marking ‘GE’ without any additional third party assessment or new authorisation for placing on the market. The use of this marking in wagons in operation remains under the responsibility of the railway undertakings.

▼ B

The detailed technical scope of this Regulation is set out in Chapter 2 of the Annex.

*Article 4***▼ M3**

1. With regard to ‘open points’ set out in Appendix A, the conditions to be complied with for the verification of the essential requirements of Directive (EU) 2016/797 shall be those laid down by national rules in force in the Member State which is part of the area of use of the vehicles covered by this Regulation.

▼ B

2. Within six months of the entry into force of this Regulation, each Member State shall send the other Member States and the Commission the following information, provided it has not already been sent to them under Decision 2006/861/EC:

- (a) the list of the applicable technical rules referred to in paragraph 1;
- (b) the conformity assessment and verification procedures to be carried out to apply those rules;

▼ M3

- (c) the bodies designated to carry out the conformity assessment and verification procedures with respect to the open points.

▼ B*Article 5***▼ M3**

1. With regard to specific cases set out in Section 7.3 of the Annex, the conditions to be met for the verification of the essential requirements of Directive (EU) 2016/797 shall be those laid down in Section 7.3 of the Annex or by national rules in force in the Member State which is part of the area of use of the vehicles covered by this Regulation.

▼ B

2. Within six months of the entry into force of this Regulation, each Member State shall notify to the other Member States and to the Commission:

- (a) the applicable technical rules referred to in paragraph 1;

▼ B

- (b) the conformity assessment and verification procedures to be carried out to apply the technical rules referred to in paragraph 1;

▼ M3

- (c) the bodies designated to carry out the conformity assessment and verification procedures for the national rules relating to the specific cases set out in point 7.3 of the Annex.

▼ B*Article 6*

1. Without prejudice to the agreements which have already been notified under Decision 2006/861/EC and shall not be notified again, Member States shall notify the Commission, within six months of the entry into force of this Regulation, any national, bilateral, multilateral or international agreements under which freight wagons, falling under the scope of this Regulation, are operated.

2. Member States shall forthwith notify the Commission any future agreements or modifications of existing agreements.

Article 7

In accordance with Article 9(3) of Directive 2008/57/EC, within one year of the entry into force of this Regulation, each Member State shall communicate to the Commission a list of projects being implemented within its territory and that are at an advanced stage of development.

*Article 8***▼ M3**

1. An EC certificate of verification for a subsystem that contains interoperability constituents which do not have an EC declaration of conformity or suitability for use may be issued during a transition period ending on 1 January 2024, provided the provisions set out in Section 6.3 of the Annex are met.

2. The production or upgrade/renewal of the subsystem using non-certified interoperability constituents shall be completed within the transition period set out in paragraph 1, including placing on the market.

▼ B

3. During the transition period set out in paragraph 1:

- (a) the reasons for non-certification of any interoperability constituents shall be properly identified in the verification procedure referred to in paragraph 1;

▼ B

- (b) the national safety authorities shall report on the use of non-certified interoperability constituents in the context of authorisation procedures in their annual report referred to in ► **M3** Article 19 of Directive (EU) 2016/798 of the European Parliament and of the Council ⁽¹⁾ ◀.

▼ M3

- 4. After a transition period ending on 1 January 2015, newly produced interoperability constituents of ‘rear-end signals’, shall be covered by the required EC declaration of conformity.

▼ M2*Article 8a***▼ M3**

1. Notwithstanding the provisions in Section 6.3 of the Annex, an EC certificate of verification may be issued for a subsystem containing components corresponding to the ‘friction element for wheel tread brakes’ interoperability constituent that does not have an EC declaration of conformity during a transition period ending on 1 January 2024, if the following conditions are met:

- (a) the component was manufactured before the date of application of this Regulation; and
- (b) the interoperability constituent has been used in a subsystem that had been approved and placed on the market in at least one Member State before the date of application of this Regulation.

2. The production, upgrade or renewal of any subsystem using non-certified interoperability constituents shall be completed, including granting authorisation for placing on the market, before the transition period set out in paragraph 1 expires.

▼ M2

3. During the transition period set out in paragraph 1:

- (a) the reasons for non-certification of any interoperability constituents shall be properly identified in the verification procedure for the subsystem referred to in paragraph 1; and
- (b) national safety authorities shall report in their annual report, as referred to in ► **M3** Article 19 of Directive (EU) 2016/798 ◀, on the use of non-certified ‘friction element for wheel tread brakes’ interoperability constituents in the context of authorisation procedures.

Article 8b

1. Until the expiry of their current approval period, ‘friction element for wheel tread brakes’ interoperability constituents listed in Appendix G of the Annex do not need to be covered by an EC declaration of conformity. During this period, ‘friction elements for wheel tread brakes’ listed in Appendix G of the Annex shall be deemed to be compliant with this Regulation.

⁽¹⁾ Directive (EU) 2016/798 of the European Parliament and of the Council of 11 May 2016 on railway safety (OJ L 138, 26.5.2016, p. 102).

▼ M2

2. After their current approval period expires, ‘friction element for wheel tread brakes’ interoperability constituents listed in Appendix G of the Annex shall be covered by EC declaration of conformity.

Article 8c

1. Notwithstanding the provisions in Section 6.3 of the Annex, an EC certificate of verification may be issued for a subsystem containing components corresponding to the ‘friction element for wheel tread brakes’ interoperability constituent that does not have an EC declaration of conformity during a transition period of 10 years after the expiry of the approval period of the interoperability constituent, if the following conditions are met:

(a) the component was manufactured before the expiry of the approval period of the interoperability constituent; and

▼ M3

(b) the interoperability constituent has been used in a subsystem that had been approved and placed on the market in at least one Member State before the expiry of its approval period.

2. The production, upgrade or renewal of any subsystem using non-certified interoperability constituents shall be completed, including granting authorisation for placing on the market, before the transition period set out in paragraph 1 expires.

▼ M2

3. During the transition period set out in paragraph 1:

(a) the reasons for non-certification of any interoperability constituents shall be properly identified in the verification procedure for the subsystem referred to in paragraph 1; and

(b) the national safety authorities shall report in their annual report, as referred to in ► **M3** Article 19 of Directive (EU) 2016/798 ◀, on the use of non-certified ‘friction element for wheel tread brakes’ interoperability constituents in the context of authorisation procedures.

▼ B*Article 9***▼ M3**

The declaration of verification and/or conformity to type of a new vehicle established in accordance with Decision 2006/861/EC shall be considered valid until the end of a transition period ending on 1 January 2017.

▼ M2*Article 9a*

The EC-type or EC design examination certificate for the ‘friction element for wheel tread brakes’ interoperability constituent shall be valid for 10 years. During that period, new constituents of the same type may be placed on the market on the basis of an EC declaration of conformity that refers to this EC-type or EC design examination certificate.

▼ B*Article 10***▼ M2**

1. The Agency shall publish on its website the list of fully approved composite brake blocks for international transport referred to in Appendix G of the Annex, for the period in which these brake blocks are not covered by EC declarations.

▼ B

2. The Agency shall keep the list referred to in paragraph 1 up to date and inform the Commission of any changes to it. The Commission shall inform the Member States of any changes to the list through the Committee established in accordance with Article 29 of Directive 2008/57/EC.

▼ M2*Article 10a*

1. In order to keep pace with technological progress, innovative solutions may be required that do not comply with the specifications set out in the Annex and/or for which the assessment methods set out in the Annex cannot be applied. In that case, new specifications and/or new assessment methods associated with those innovative solutions shall be developed.

2. Innovative solutions may be related to the ‘rolling stock — freight wagons’ subsystem, its parts and its interoperability constituents.

3. If an innovative solution is proposed, the manufacturer or his authorised representative established within the Union shall declare how it deviates from or complements the relevant provisions of this TSI and shall submit the deviations to the Commission for analysis.

4. The Commission shall deliver an opinion on the innovative solution proposed. If this opinion is positive, the appropriate functional and interface specifications and the assessment method, which must be included in the TSI in order to allow the use of this innovative solution, shall be developed and subsequently integrated in the TSI during the revision process carried out pursuant to ► **M3** Article 5 of Directive (EU) 2016/797 ◀. If the opinion is negative, the innovative solution proposed shall not be applied.

5. Pending the review of the TSI, the positive opinion delivered by the Commission shall be considered an acceptable means of compliance with the essential requirements of ► **M3** Directive (EU) 2016/797 ◀ and may therefore be used for the assessment of the subsystem.

▼ B*Article 11*

Decision 2006/861/EC is repealed with effect from 1 January 2014.

It shall continue to apply, however, to the maintenance of projects authorised in accordance with that Decision and, unless the applicant requests to apply this Regulation, to projects for new, renewed or upgraded subsystems which are at an advanced stage of development or are the subject of a contract which is being carried out on the date this Regulation is published.

▼B*Article 12*

This Regulation shall enter into force on the day following that of its publication in the *Official Journal of the European Union*.

It shall apply from 1 January 2014. However, an authorisation for placing into service may be granted in application of the TSI as set out in the Annex to this Regulation, except its Section 7.1.2, before 1 January 2014.

This Regulation shall be binding in its entirety and directly applicable in all Member States.



ANNEX

Technical specification for interoperability for the ‘rolling stock — wagons’ subsystem

TABLE OF CONTENTS

1.	Introduction
1.1.	Technical scope
1.2.	Geographical scope
1.3.	Content of this TSI
2.	Scope and definition of subsystem
3.	Essential requirements
4.	Characterisation of the subsystem
4.1.	Introduction
4.2.	Functional and technical specifications of the subsystem
4.2.1.	General
4.2.2.	Structures and mechanical part
4.2.2.1.	Mechanical interface
4.2.2.1.1.	End coupling
4.2.2.1.2.	Inner coupling
4.2.2.2.	Strength of unit
4.2.2.3.	Integrity of the unit
4.2.3.	Gauging and track interaction
4.2.3.1.	Gauging
4.2.3.2.	Compatibility with load carrying capacity of lines
4.2.3.3.	Compatibility with train detection systems
4.2.3.4.	Axle bearing condition monitoring
4.2.3.5.	Running safety
4.2.3.5.1.	Safety against derailment running on twisted track
4.2.3.5.2.	Running dynamic behaviour
4.2.3.6.	Running gear
4.2.3.6.1.	Structural design of bogie frame
4.2.3.6.2.	Characteristics of wheelsets
4.2.3.6.3.	Characteristics of wheels
4.2.3.6.4.	Characteristics of axles
4.2.3.6.5.	Axle boxes/bearings
4.2.3.6.6.	Automatic variable gauge systems
4.2.3.6.7.	Running gear for manual change of wheelsets
4.2.4.	Brake
4.2.4.1.	General
4.2.4.2.	Safety requirements
4.2.4.3.	Functional and technical requirements
4.2.4.3.1.	General functional requirements
4.2.4.3.2.	Brake performance
4.2.4.3.2.1.	Service brake

▼B

- 4.2.4.3.2.2. Parking brake
- 4.2.4.3.3. Thermal capacity
- 4.2.4.3.4. Wheel slide protection (WSP)
- 4.2.4.3.5. Friction elements for wheel tread brakes
- 4.2.5. Environmental conditions
- 4.2.6. System protection
 - 4.2.6.1. Fire safety
 - 4.2.6.1.1. General
 - 4.2.6.1.2. Functional and technical specification
 - 4.2.6.1.2.1. Barriers
 - 4.2.6.1.2.2. Materials
 - 4.2.6.1.2.3. Cables
 - 4.2.6.1.2.4. Flammable liquids
 - 4.2.6.2. Protection against electrical hazards
 - 4.2.6.2.1. Protective measures against indirect contact (protective bonding)
 - 4.2.6.2.2. Protective measures against direct contact
 - 4.2.6.3. Attachment devices for rear-end signal
- 4.3. Functional and technical specification of the interfaces
 - 4.3.1. Interface with the subsystem ‘infrastructure’
 - 4.3.2. Interface with the subsystem ‘operation and traffic management’
 - 4.3.3. Interface with the subsystem ‘control, command and signalling’
- 4.4. Operating rules
- 4.5. Maintenance rules
 - 4.5.1. General documentation
 - 4.5.2. Maintenance design justification file
 - 4.5.3. Maintenance description file
- 4.6. Professional competencies
- 4.7. Health and safety conditions
- 4.8. Parameters to be recorded in the technical file and European register of authorised types of vehicles

▼M3

- 4.9. Route compatibility checks before the use of authorised vehicles

▼B

- 5. Interoperability constituents
 - 5.1. General
 - 5.2. Innovative solutions
 - 5.3. Interoperability constituent specifications
 - 5.3.1. Running gear
 - 5.3.2. Wheelset
 - 5.3.3. Wheel
 - 5.3.4. Axle

▼ M2

5.3.4a. Friction element for wheel tread brakes

▼ M3

5.3.4b. Automatic variable gauge system

▼ B

5.3.5. Rear-end signal

6. Conformity assessment and EC verification

6.1. Interoperability constituent

6.1.1. Modules

6.1.2. Conformity assessment procedures

6.1.2.1. Running gear

6.1.2.2. Wheelset

6.1.2.3. Wheel

6.1.2.4. Axle

▼ M2

6.1.2.5. Friction elements for wheel tread brakes

▼ M3

6.1.2.6. Automatic variable gauge system

▼ B

6.1.3. Innovative solutions

6.2. Subsystem

6.2.1. Modules

6.2.2. EC verification procedures

6.2.2.1. Strength of unit

6.2.2.2. Safety against derailment running on twisted track

6.2.2.3. Running dynamic behaviour

6.2.2.4. Axle box/bearings

▼ M3

6.2.2.4a. Automatic variable gauge systems

▼ B

6.2.2.5. Running gear for manual change of wheelsets

6.2.2.6. Thermal capacity

6.2.2.7. Environmental conditions

6.2.2.8. Fire safety

6.2.2.8.1. Barriers

6.2.2.8.2. Materials

6.2.2.8.3. Cables

6.2.2.8.4. Flammable liquids

6.2.3. Innovative solutions

6.3. Subsystem containing components corresponding to interoperability constituents not holding an EC declaration

6.4. Project phases where assessment is required

6.5. Constituents holding an EC declaration of conformity

7. Implementation

7.1. Authorisation for placing on the market

7.1.1. Authorisation for placing into service of a new vehicle in conformity with previous WAG TSIs

▼ B

- 7.1.2. Mutual recognition of the first authorisation of placing on the market
- 7.2. General rules for implementation
 - 7.2.1. Substitution of constituents
- 7.3. Specific cases
 - 7.3.1. Introduction
 - 7.3.2. List of specific cases
 - 7.3.2.1. General specific cases

▼ M3

- 7.3.2.1a. Gauging (point 4.2.3.1)

▼ B

- 7.3.2.2. Axle bearing condition monitoring (point 4.2.3.4)
- 7.3.2.3. Safety against derailment running on twisted track (point 4.2.3.5.1)
- 7.3.2.4. Running dynamic behaviour (point 4.2.3.5.2)
- 7.3.2.5. Characteristics of wheelsets, wheels and axles (points 4.2.3.6.2 and 4.3.2.6.3)
- 7.3.2.6. Attachment devices for rear-end signals (point 4.2.6.3)

▼ M3

- 7.3.2.7. Rules to manage changes in both rolling stock and rolling stock type (7.2.2.2)

▼ B

- 7.4. Specific environmental conditions
- 7.5. Freight wagons operating under national, bilateral, multilateral or international agreements

▼ M3

- 7.6. Aspects that have to be considered in the revision process or in other activities of the Agency
 - 7.6.1. Rules for extension of area of use for existing rolling stock not covered by an EC declaration of verification

▼ B

- Appendices

▼ B

1. INTRODUCTION

A Technical Specification for Interoperability (TSI) is a specification that covers a subsystem (or part of it) as described in Article 2(i) of ►**M3** Directive (EU) 2016/797 ◀ in order:

- to ensure the interoperability of the rail system, and
- to meet the essential requirements.

1.1. **Technical scope**

See Article 2 of this Regulation.

▼ M31.2. **Geographical scope**

The geographical scope of this TSI is the entire European Union's rail system as set out in the section 1 of Annex I to Directive (EU) 2016/797, taking into account the limitations concerning the track gauge set out in Article 2.

▼ B1.3. **Content of this TSI**

In accordance with Article 5(3) of ►**M3** Directive (EU) 2016/797 ◀, this TSI:

- (a) indicates its intended scope (Chapter 2);
- (b) lays down essential requirements for the part of the rolling stock subsystem concerned and for its interfaces vis-à-vis other subsystems (Chapter 3);
- (c) establishes the functional and technical specifications to be met by the subsystem and its interfaces vis-à-vis other subsystems (Chapter 4).
- (d) determines the interoperability constituents and interfaces which must be covered by European specifications, including European standards, which are necessary to achieve interoperability within the rail system (Chapter 5);
- (e) states, in each case under consideration, which procedures are to be used in order to assess the conformity or the suitability for use of the interoperability constituents and the 'EC' verification of the subsystems (Chapter 6);
- (f) indicates the strategy for implementing the TSIs (Chapter 7);
- (g) indicates, for the staff concerned, the professional qualifications and health and safety conditions at work that are required for the operation and maintenance of the above subsystem, as well as for the implementation of this TSI (Chapter 4).

▼ M3

2. SCOPE AND DEFINITION OF SUBSYSTEM

2.1. **Scope**

This TSI is applicable to 'freight wagons including vehicles designed to carry lorries' as referred to in Annex I Section 2 to Directive (EU) 2016/797 taking into account the limitations as set out in Article 2. In the following this part of the subsystem rolling stock is called 'freight wagon' and belongs to the subsystem 'rolling stock' as set out in Annex II to Directive 2016/797/EC.

▼ M3

The other vehicles listed in Section 2 of Annex I to Directive (EU) 2016/797 are excluded from the scope of this TSI; this is especially the case for:

- (a) mobile railway infrastructure construction and maintenance equipment;
- (b) vehicles designed to carry:
 - motor vehicles with their passengers on board, or
 - motor vehicles without passengers on board but intended to be integrated in passenger trains (car carriers);
- (c) vehicles which
 - increase their length in loaded configuration, and
 - their payload itself is part of the vehicle structure.

Note: See also section 7.1 for particular cases.

2.2. Definitions

In the present TSI the following definitions are used:

- (a) A ‘unit’ is the generic term used to name the rolling stock. It is subject to the application of this TSI, and therefore subject to the EC verification procedure.

A unit can consist of:

- a ‘wagon’ that can be operated separately, featuring an individual frame mounted on its own set of wheels, or
- a rake of permanently connected ‘elements’, those elements cannot be operated separately, or
- ‘separate rail bogies connected to compatible road vehicle(s)’ the combination of which forms a rake of a rail compatible system.

- (b) A ‘train’ is an operational formation consisting of several units.
- (c) The ‘design operating state’ covers all conditions under which the unit is intended to operate and its technical boundaries. This design operating state may go beyond the specifications of this TSI in order that units may be used together in a train on the network under the safety management system of a railway undertaking.

▼ B

3. ESSENTIAL REQUIREMENTS

Article 4(1) of ►**M3** Directive (EU) 2016/797 ◀ states, that the rail system its subsystems and their interoperability constituents shall meet the relevant essential requirements. The essential requirements are set out in general terms in Annex III to ►**M3** Directive (EU) 2016/797 ◀. Table 1 indicates the basic parameters specified in this TSI and their correspondence to the essential requirements as explained in Annex III to ►**M3** Directive (EU) 2016/797 ◀.



Table 1

Basic parameters and their correspondence to the essential requirements

Point	Basic parameter	Essential requirements				
		Safety	Reliability and availability	Health	Environment protection	Technical compatibility
4.2.2.1.1	End coupling	1.1.1, 1.1.3, 1.1.5, 2.4.1				
4.2.2.1.2	Inner coupling	1.1.1, 1.1.3, 2.4.1				
4.2.2.2	Strength of unit	1.1.1, 1.1.3, 2.4.1				
4.2.2.3	Integrity of the unit	1.1.1				
4.2.3.1	Gauging	1.1.1				2.4.3
4.2.3.2	Compatibility with load carrying capacity of lines	1.1.1				2.4.3
4.2.3.3	Compatibility with train detection systems	1.1.1				2.4.3
4.2.3.4	Axle bearing condition monitoring	1.1.1	1.2			2.4.3
4.2.3.5.1	Safety against derailment running on twisted track	1.1.1, 1.1.2, 2.4.1				2.4.3
4.2.3.5.2	Running dynamic behaviour	1.1.1 1.1.2				2.4.3
4.2.3.6.1	Structural design of bogie frame	1.1.1, 1.1.2, 1.1.3				
4.2.3.6.2	Characteristics of wheelsets	1.1.1, 1.1.2, 1.1.3				2.4.3
4.2.3.6.3	Characteristics of wheels	1.1.1, 1.1.2, 1.1.3				2.4.3

▼B

Point	Basic parameter	Essential requirements				
		Safety	Reliability and availability	Health	Environment protection	Technical compatibility
4.2.3.6.4	Characteristics of axles	1.1.1, 1.1.2, 1.1.3				
4.2.3.6.5	Axle box/bearings	1.1.1, 1.1.2, 1.1.3				
4.2.3.6.6	Automatic variable gauge systems	1.1.1, 1.1.2, 1.1.3	1.2			1.5
4.2.3.6.7	Running gear for manual change of wheelsets	1.1.1, 1.1.2, 1.1.3				
4.2.4.2	Brake — Safety requirements	1.1.1, 1.1.3	1.2 2.4.2			
4.2.4.3.1	Brake — General functional requirements	1.1.1 2.4.1	2.4.2			
4.2.4.3.2.1	Brake performance — In-service brake	1.1.1, 1.1.2 2.4.1	2.4.2			1.5
4.2.4.3.2.2	Brake performance — Parking brake	2.4.1				2.4.3
4.2.4.3.3	Brake — Thermal capacity	1.1.1, 1.1.3 2.4.1				2.4.3
4.2.4.3.4	Brake — Wheel slide protection (WSP)	2.4.1	2.4.2			
4.2.4.3.5	Friction elements for wheel tread brakes	1.1.1, 1.1.2, 1.1.3, 2.4.1				2.4.3
4.2.5	Environmental conditions	1.1.1 1.1.2				2.4.3
4.2.6.1	Fire safety	1.1.1 1.1.4				
4.2.6.1.2.1	Fire safety Barriers	1.1.4		1.3.2	1.4.2	

▼M3**▼B****▼M2****▼B**

▼ B

Point	Basic parameter	Essential requirements				
		Safety	Reliability and availability	Health	Environment protection	Technical compatibility
4.2.6.1.2.2	Fire safety Materials	1.1.4		1.3.2	1.4.2	
4.2.6.1.2.3	Fire safety Cables	1.1.4 1.1.5		1.3.2	1.4.2	
4.2.6.1.2.4	Fire safety — Flammable liquids	1.1.4		1.3.2	1.4.2	
4.2.6.2	Protection against electric hazard	1.1.5 2.4.1				
4.2.6.3	Attachment device for rear-end signal	1.1.1				

The essential requirements 1.3.1, 1.4.1, 1.4.3, 1.4.4 and 1.4.5 of Annex III to ►**M3** Directive (EU) 2016/797 ◀ fall under the scope of other Union legislation.

4. CHARACTERISATION OF THE SUBSYSTEM

4.1. Introduction

The rail system, to which ►**M3** Directive (EU) 2016/797 ◀ applies and of which freight wagons form a part, is an integrated system whose consistency shall be verified. This consistency shall be checked in particular with regard to the specifications of the rolling stock subsystem and the compatibility with the network (Section 4.2), its interfaces in relation to the other subsystems of the rail system in which it is integrated (Sections 4.2 and 4.3), as well as the initial operating and maintenance rules (Sections 4.4 and 4.5) as requested by Article 18(3) of ►**M3** Directive (EU) 2016/797 ◀.

The technical file, as set out in Article 18(3) and Annex VI to ►**M3** Directive (EU) 2016/797 ◀ (Section 4.8), shall contain in particular design related values concerning the compatibility with the network.

4.2. Functional and technical specifications of the subsystem

4.2.1. General

In light of the essential requirements in Chapter 3, the functional and technical specifications of the subsystem 'rolling stock — freight wagons' are grouped and sorted out in the following points of this Chapter:

- Structures and mechanical parts
- Gauging and vehicle track interaction
- Brake
- Environmental conditions
- System protection.

Except where this is strictly necessary for the interoperability of the rail system and to meet the relevant essential requirements, the functional and technical specifications of the freight wagon and its interfaces do not impose the use of any particular technical solutions.

▼ M2

▼B

When the functional and technical specifications that are necessary in order to achieve interoperability and to meet the essential requirements, have not been developed concerning a particular technical aspect, this aspect is identified as an open point in the relevant point. As required in Article 5(6) of ►**M3** Directive (EU) 2016/797 ◀ all open points are listed in Appendix A.

In Appendix C a set of conditions is specified. The conformity with this set of conditions is optional. If this option is selected, the conformity shall be assessed by a notified body within the EC verification procedure.

In accordance with Article 5(5) of ►**M3** Directive (EU) 2016/797 ◀, provision may be made for specific cases for each TSI. Such provisions are indicated in Chapter 7.

As far as possible the assessment procedure for the requirements in Section 4.2 is defined in Chapter 6. In these cases the text of Section 4.2 makes a reference to the corresponding points and sub points clauses of Chapter 6. If for a particular basic parameter the separation of requirements and assessment procedures is not feasible, no reference is given.

4.2.2. *Structures and mechanical parts*

4.2.2.1. Mechanical interface

4.2.2.1.1. *End coupling*

The end coupling is the mechanical interface between units forming a train.

The coupling system shall be designed in a way that no human presence between the units to be coupled/uncoupled shall be required whilst either one unit is moving.

End couplings shall be resilient and capable of withstanding the forces in accordance with the defined design operating state of the unit.

4.2.2.1.2. *Inner coupling*

The inner coupling is the mechanical interface between elements forming a unit.

The inner coupling shall be resilient and capable of withstanding the forces in accordance with the defined design operating state of the unit. The joint between two elements sharing the same running gear, is covered by point 4.2.2.2.

The longitudinal strength of the inner coupling(s) shall be equal to or higher than the one of the end coupling(s) of the unit.

▼M3

4.2.2.2. The structure of a unit body, any equipment attachments and lifting and jacking points shall be designed such that no cracks, no significant permanent deformation or ruptures occur under the load cases defined in Chapter 5 of EN 12663-2:2010.

In case of a rake of a rail compatible system composed of separate rail bogies connected to compatible road vehicles, the load cases may differ from those mentioned above, due to their bi-modal specification; in such a case, the load cases considered shall be described by the applicant based on a consistent set of specifications with consideration of the specific conditions of use related to train composition, shunting and operation.

▼ M3

The demonstration of conformity is described in point 6.2.2.1.

The lifting and jacking positions shall be marked on the unit. The marking shall comply with point 4.5.14 of EN 15877-1:2012.

Note: Joining techniques are deemed to be covered as well by the demonstration of conformity in accordance to point 6.2.2.1.

▼ B

4.2.2.3. Integrity of the unit

The unit shall be designed so that all movable parts intended to close an aperture (access doors, tarpaulin, lids, hatches, etc.) are prevented against an unintentional movement of these parts.

Locking devices shall indicate their status (open/closed) and shall be visible outside the unit.

4.2.3. Gauging and track interaction

4.2.3.1. Gauging

This point concerns the rules for calculation intended for sizing the rolling stock to run on one or several networks without interference risk.

The compliance of a unit with the intended reference profile including the reference profile for the lower part shall be established by one of the methods set out in ► M3 EN 15273-2:2013+A1:2016 ◀.

The kinematic method, as described in ► M3 EN 15273-2:2013+A1:2016 ◀ shall be used to establish conformity, if any, between the reference profile established for the unit and the respective target reference profiles G1, GA, GB and GC including those used for the lower part ► M3 G11 and G12 ◀.

4.2.3.2. Compatibility with load carrying capacity of lines

The vertical loading characteristics of the unit shall be determined in order to check compatibility with the load carrying capacity of lines.

The permissible payload a unit may carry, for axle loads up to and including 25 t, shall be determined by application of clauses 6.1 and 6.2 of ► M3 EN 15528:2015 ◀.

4.2.3.3. Compatibility with train detection systems

If the unit is intended to be compatible with one or more of the following train detection systems, this compatibility shall be established according to the provisions of the ► M3 ERA/ERTMS/033281 rev. 4.0 ◀ ► M3 ————— ◀:

- (a) train detection systems based on track circuits;
- (b) train detection systems based on axle counters;
- (c) train detection systems based on loop equipment.

4.2.3.4. Axle bearing condition monitoring

It shall be possible to monitor the axle bearing condition either by:

- line side detection equipment, or
- on-board equipment.

▼B

If the unit is intended to be capable of being monitored by line side equipment on the 1 435 mm track gauge network the unit shall be compliant with clauses 5.1 and 5.2 of EN 15437-1:2009 in order to ensure sufficient visibility.

For units intended to be operated on the networks with track gauges of 1 524 mm, 1 600 mm, 1 668 mm, the corresponding values in Table 2 referring to the parameters of the standard EN 15437-1:2009 shall be applied.

Table 2

Target and prohibitive zone for units intended to be operated on particular networks

	Y _{TA} [mm]	W _{TA} [mm]	L _{TA} [mm]	Y _{PZ} [mm]	W _{PZ} [mm]	L _{PZ} [mm]
1 524 mm (both areas are relevant)	1 080 ± 35	≥ 50	≥ 200	1 080 ± 5	≥ 140	≥ 500
	894 ± 2	≥ 14	≥ 200	894 ± 2	≥ 28	≥ 500
1 600 mm	1 110 ± 2	≥ 70	≥ 180	1 110 ± 2	≥ 125	≥ 500
1 668 mm	1 176 ± 10	≥ 55	≥ 100	1 176 ± 10	≥ 110	≥ 500

▼M3

If the unit is intended to be capable of being monitored by on-board equipment, the following requirements shall apply:

- This equipment shall be able to detect a deterioration of any of the axle box bearings of the unit.
- The bearing condition shall be evaluated either by monitoring its temperature, or its dynamic frequencies or some other suitable bearing condition characteristic.
- The detection system shall be located entirely on board the unit, and diagnosis messages shall be available on board the unit.
- The diagnosis messages delivered and how they are made available shall be described in the operating documentation set out in section 4.4 of this TSI, and in the maintenance rules described in section 4.5 of this TSI.

▼B

4.2.3.5. Running safety

The dynamic behaviour of a vehicle has a strong influence on safety against derailment, running safety and track loading.

4.2.3.5.1. *Safety against derailment running on twisted track*

The unit shall be designed to ensure safe running on twisted track, taking into account specifically the transition phase between canted and level track and cross level deviations.

The demonstration of conformity is described in point 6.2.2.2.

4.2.3.5.2. *Running dynamic behaviour*

The unit shall be designed to provide safe movement up to the maximum design speed.

▼B

The running dynamic behaviour of a unit shall be proven either by:

- following the procedures set out in ► **M3** chapters 4, 5 and 7 of EN 14363:2016 ◀, or
- performing simulations using a validated model.

The demonstration of conformity is described in point 6.2.2.3.

▼M1

Running dynamic behaviour is permitted to be assessed at interoperability constituent level in accordance with point 6.1.2.1. In this case a specific test or simulation at subsystem level is not required.

▼B

4.2.3.6. Running gear

The running gear guarantees to carry and guide the unit safely as well as to transmit braking forces where so required.

4.2.3.6.1. *Structural design of bogie frame*

The integrity of the structure of a bogie frame, all attached equipment and body to bogie connection shall be demonstrated based on methods as set out in point 6.2 of EN 13749:2011.

▼M1

The integrity of the structure of a bogie frame is permitted to be assessed at interoperability constituent level in accordance with point 6.1.2.1. In this case a specific test or simulation at subsystem level is not required.

▼B4.2.3.6.2. *Characteristics of wheelsets*

The wheelset assembly shall be able to transmit forces and torque between the fitted parts in accordance with the area of use.

The geometric dimensions of the wheelsets, as defined in Figure 1, shall be compliant with limit values specified in Table 3. These limit values shall be taken as design values and shall be stated as in-service limit values in the maintenance file described in Section 4.5.

The demonstration of conformity is described in point 6.1.2.2.

Figure 1

Symbols for wheelsets used in Table 3

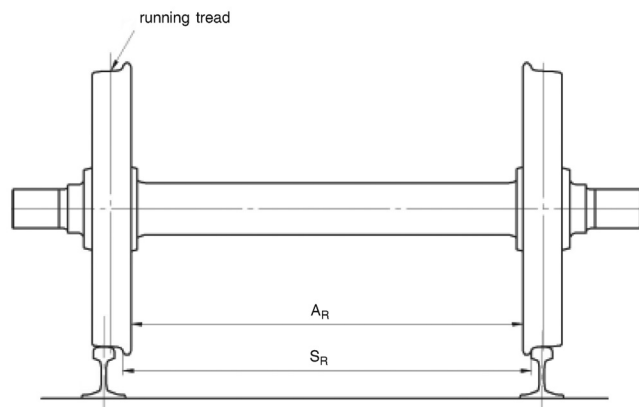



Table 3

Limits of use of the geometric dimensions of wheelsets

Designation		Wheel diam. D [mm]	Minimum value [mm]	Maximum value [mm]
1 435 mm	Front-to-front dimension (S_R) $S_R = A_R + S_{d, \text{left}} + S_{d, \text{right}}$	$330 \leq D \leq 760$	1 415	1 426
		$760 < D \leq 840$	1 412	1 426
		$D > 840$	1 410	1 426
	Back to back distance (A_R)	$330 \leq D \leq 760$	1 359	1 363
		$760 < D \leq 840$	1 358	1 363
		$D > 840$	1 357	1 363
1 524 mm	Front-to-front dimension (S_R) $S_R = A_R + S_{d, \text{left}} + S_{d, \text{right}}$	$400 \leq D < 840$	1 492	1 514
		$D \geq 840$	1 487	1 514
	Back to back distance (A_R)	$400 \leq D < 840$	1 444	1 448
		$D \geq 840$	1 442	1 448
1 600 mm	Front-to-front dimension (S_R) $S_R = A_R + S_{d, \text{left}} + S_{d, \text{right}}$	$690 \leq D \leq 1\,016$	1 573	1 592
	Back to back distance (A_R)	$690 \leq D \leq 1\,016$	1 521	1 526
1 668 mm	Front-to-front dimension (S_R) $S_R = A_R + S_{d, \text{left}} + S_{d, \text{right}}$	$330 \leq D < 840$	1 648 ⁽¹⁾	1 659
		$840 \leq D \leq 1\,250$	1 643 ⁽¹⁾	1 659
	Back to back distance (A_R)	$330 \leq D < 840$	1 592	1 596
		$840 \leq D \leq 1\,250$	1 590	1 596

⁽¹⁾ Two-axle wagons with axle load up to 22,5 t the value shall be taken as 1 651 mm.

4.2.3.6.3. Characteristics of wheels

The geometrical dimensions of the wheels as defined in Figure 2 shall be compliant with limit values specified in Table 4.

Table 4

Limits of use of the geometric dimensions of wheels

Designation		Wheel diam. D [mm]	Minimum value [mm]	Maximum value [mm]
1 435 mm	Width of the rim (B_R) (with maximum BURR of 5 mm)	$D \geq 330$	133	140
	Thickness of the flange (S_d)	$330 \leq D \leq 760$	27,5	33
		$760 < D \leq 840$	25	33
		$D > 840$	22	33
	Height of the flange (S_h)	$330 \leq D \leq 630$	31,5	36
		$630 < D \leq 760$	29,5	36
		$D > 760$	27,5	36
	Face of the flange (q_R)	$D \geq 330$	6,5	—

▼B

Designation		Wheel diam. D [mm]	Minimum value [mm]	Maximum value [mm]
1 524 mm	Width of the rim (B_R) (with maximum BURR of 5 mm)	$D \geq 400$	134	140
	Thickness of the flange (S_d)	$400 \leq D < 760$	27,5	33
		$760 \leq D < 840$	25	33
		$D \geq 840$	22	33
	Height of the flange (S_h)	$400 \leq D < 630$	31,5	36
		$630 \leq D < 760$	29,5	36
$D \geq 760$		27,5	36	
Face of the flange (q_R)	$D \geq 400$	6,5	—	
1 600 mm	Width of the rim (B_R) (with maximum BURR of 5 mm)	$690 \leq D \leq 1\ 016$	137	139
	Thickness of the flange (S_d)	$690 \leq D \leq 1\ 016$	26	33
	Height of the flange (S_h)	$690 \leq D \leq 1\ 016$	28	38
	Face of the flange (q_R)	$690 \leq D \leq 1\ 016$	6,5	—
1 668 mm	Width of the rim (B_R) (with maximum BURR of 5 mm)	$D \geq 330$	133	140
	Thickness of the flange (S_d)	$330 \leq D \leq 840$	27,5	33
		$D > 840$	22 (PT); 25 (ES)	33
	Height of the flange (S_h)	$330 \leq D \leq 630$	31,5	36
		$630 \leq D \leq 760$	29,5	36
$D > 760$		27,5	36	
Face of the flange (q_R)	$D \geq 330$	6,5	—	

These limit values shall be taken as design values and shall be stated as in-service limit values in the maintenance file described in Section 4.5.

Figure 2

Symbols for wheels used in Table 4

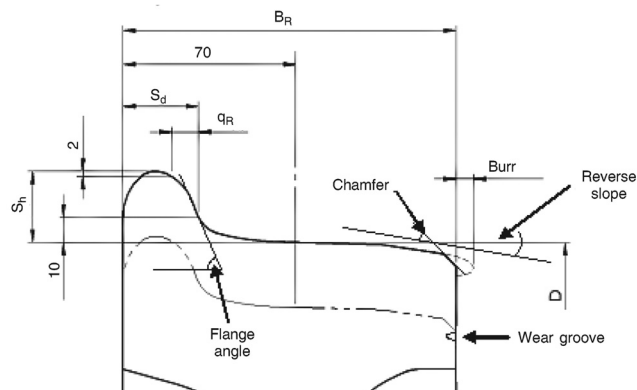

▼ B

The mechanical characteristics of the wheels shall ensure the transmission of forces and torque as well as the resistance against thermal load where so required in accordance with the area of use.

The demonstration of conformity is described in point 6.1.2.3.

4.2.3.6.4. *Characteristics of axles*

The characteristics of the axle shall ensure the transmission of forces and torque in accordance with the area of use.

The demonstration of conformity is described in point 6.1.2.4.

The traceability of axles shall take into accounts the findings of the ERA Task force on Freight Maintenance (see ‘*Final report on the activities of the Task Force Freight Wagon Maintenance*’ published on the ERA website <http://www.era.europa.eu>).

4.2.3.6.5. *Axle boxes/bearings*

The axle box and the rolling bearing shall be designed with consideration of mechanical resistance and fatigue characteristics. Temperature limits reached in service relevant for the hot box detection shall be defined.

The demonstration of conformity is described in point 6.2.2.4.

▼ M34.2.3.6.6. *Automatic variable gauge systems*

This requirement is applicable to units equipped with an automatic variable gauge system with changeover mechanism of the axial position of the wheels allowing the unit to be compatible with 1 435 mm track gauge and other track gauge(s) within the scope of this TSI by means of passage through a track gauge changeover facility.

The changeover mechanism shall ensure the locking in the correct intended axial position of the wheel.

After passage through the track gauge changeover facility, the verification of the state of the locking system (locked or unlocked) and of the position of the wheels shall be performed by one or more of the following means: visual control, on-board control system or infrastructure/facility control system. In case of on-board control system, a continuous monitoring shall be possible.

If a running gear is equipped with brake equipment subject to a change in position during the gauge change operation, the automatic variable gauge system shall ensure the position and safe locking in the correct position of this equipment simultaneously to those of the wheels.

The failure of the locking of the position of the wheels and braking equipment (if relevant) during operation has typical credible potential to lead directly to a catastrophic accident (resulting in multiple fatalities); considering this severity of the failure consequence, it shall be demonstrated that the risk is controlled to an acceptable level.

The automatic variable gauge system is defined as an interoperability constituent (point 5.3.4b) and is part of the interoperability constituent wheelset (point 5.3.2). The conformity assessment procedure is specified in point 6.1.2.6 (interoperability constituent level), point 6.1.2.2 (safety requirement) and in point 6.2.2.4a (sub-system level) of this TSI.

▼ M3

The track gauges the unit is compatible with shall be recorded in the technical documentation.

A description of the changeover operation in normal mode, including the type(s) of track gauge changeover facility(ies) the unit is compatible with, shall be part of the technical documentation (see also section 4.4 of this TSI).

The requirements and conformity assessments required in other sections of this TSI apply independently for each wheel position corresponding to one track gauge and have to be documented accordingly.

▼ B4.2.3.6.7. *Running gear for manual change of wheelsets*

The requirement is applicable to units prepared to run on different track gauges, by means of a physical change of wheelset.

The unit shall be equipped with a locking mechanism in order to ensure the correct position of its brake equipment in the different configurations considering the dynamic effects in accordance with the design operating state of the unit.

The demonstration of conformity is described in point 6.2.2.5.

4.2.4. *Brake*4.2.4.1. *General*

The purpose of the train brake system is to ensure that:

- the train's speed can be reduced,
- the train's speed can be maintained on a slope,
- the train can be stopped within the maximum allowable braking distance, and that
- the train can be immobilised.

Primary factors that influence the braking performance and the braking process are:

- the braking power,
- the train mass,
- the speed,
- the allowable braking distance,
- the available adhesion, and
- the track gradient.

The brake performance of a train is derived from the individual brake performance of each unit in the train.

▼B

4.2.4.2. Safety requirements

The braking system contributes to the safety level of the railway system. Therefore the design of the braking system of a unit has to undergo a risk assessment in accordance with ►**M3** Commission Implementing Regulation (EU) No 402/2013 ⁽¹⁾ ◀ considering the hazard of complete loss of the brake capability of the unit. The severity level shall be deemed as catastrophic when:

- it affects the unit alone (combination of failures), or
- it affects the brake capability of more than the unit (single fault).

The fulfilment of the conditions of C.9 and C.14 of Appendix C is presumed to be in conformity with this requirement.

4.2.4.3. Functional and technical requirements

4.2.4.3.1. *General functional requirements*

The brake equipment of the unit shall provide the functions of braking such as the application and the release of the brake, upon a transmitted signal. The brake shall be:

- continuous (the brake application or release signal is transmitted from a central command to the whole train by a control line),
- automatic (an inadvertent disruption of the control line shall lead to brake activation on all units of the train bringing each part to stand still),
- disengageable, which enables its release and isolation.

4.2.4.3.2. *Brake performance*

4.2.4.3.2.1. Service brake

The brake performance of a train or a unit is its ability to decelerate. It is the result of the braking power available to decelerate the train or unit within defined limits and all factors involved in the conversion and dissipation of energy including train resistance.

The brake performance of a unit shall be calculated in accordance with one of the following documents:

- EN 14531-6:2009, or

▼M1

- ►**M3** UIC 544-1:2014 ◀

The calculation shall be validated by tests. Brake performance calculation in accordance with UIC 544-1 shall be validated as set out in ►**M3** UIC 544-1:2014 ◀.

⁽¹⁾ ►**M3** OJ L 121, 3.5.2013, p. 8. ◀

▼ B

4.2.4.3.2.2. Parking brake

A Parking Brake is a brake used to prevent parked rolling stock moving under the specified conditions taking into account the place, wind, gradient and rolling stock loading state, until intentionally released.

If the unit is equipped with a parking brake, the following requirements shall be met:

- the immobilisation shall remain until intentionally released,
- where it is not possible to identify the state of the parking brake directly, an indicator showing the state shall be provided on both sides on the outside of the vehicle,

▼ M1

- ► **M3** the minimum parking brake force ◀, considering no wind, shall be determined by calculations as defined in Clause 6 of EN 14531-6:2009,

▼ B

- ► **M3** ————— ◀ The parking brake of a unit shall be designed considering a wheel/rail (steel/steel) adhesion factor not higher than 0,12.

4.2.4.3.3. *Thermal capacity*

The brake equipment shall be able to withstand one emergency brake application without any loss of brake performance due to thermal or mechanical effects.

▼ M1

The thermal load that the unit is capable of withstanding without any adverse loss of brake performance due to thermal or mechanical effects, shall be defined and expressed in terms of speed, axle load, gradient and brake distance.

▼ B

The demonstration of conformity is described in point 6.2.2.6.

A slope of 21 ‰ at 70 km/h during 40 km may be considered as the reference case for the thermal capacity which results in a braking power of 45 kW per wheel during 34 minutes for a nominal wheel diameter of 920 mm and an axle load of 22,5 t.

4.2.4.3.4. *Wheel slide protection (WSP)*

Wheel slide protection (WSP) is a system designed to use the maximum available adhesion by decreasing, holding or increasing the brake force to prevent wheel sets from locking and uncontrolled sliding. Thereby the stopping distance shall be optimised.

▼ B

If an electronic WSP-control is used negative effects caused by malfunctions of WSP shall be reduced by suitable system design processes and technical configuration.

The WSP shall not alter the functional characteristics of the brakes. The vehicle's air equipment shall be dimensioned such that the air consumption of the WSP does not impair the performance of the pneumatic brake. The design process of the WSP shall take into account that the WSP has no detrimental effect on the constituent parts of the vehicle (brake gear, wheel tread, axle boxes, etc.).

▼ M1

The following types of units shall be fitted with WSP:

- types of units equipped with all types of brake blocks except composite brake blocks, for which the maximum mean utilisation of adhesion is greater than 0,12,
- types of units equipped with disc brakes only and/or with composite brake blocks, for which the maximum mean utilisation of adhesion is greater than 0,11.

▼ M24.2.4.3.5. *Friction elements for wheel tread brakes*

The friction element for wheel tread brakes (i.e. brake block) generates brake forces by friction when engaged with the wheel tread.

If wheel tread brakes are used the characteristics of the friction element shall contribute reliably to achieving the intended brake performance.

The demonstration of conformity is described in point 6.1.2.5 of this TSI.

▼ B4.2.5. *Environmental conditions*

The design of the unit, as well as its constituents shall take into account the environmental conditions to which this rolling stock will be subjected to.

The environmental parameters are described in the clauses below. For each environmental parameter, a nominal range is defined, which is the most commonly encountered in Europe, and is the basis for the interoperable unit.

For certain environmental parameters ranges other than the nominal one are defined. In that case, a range shall be selected for the design of the unit.

For the functions identified in the clauses below, design and/or testing provisions taken to ensure that the rolling stock is meeting the TSI requirements in this range shall be described in the technical file.

Depending on the ranges selected and on provisions taken (described in the technical file), appropriate operating rules could be necessary when the unit designed for the nominal range is operated on a particular line where the nominal range is exceeded at certain periods of the year.

▼ B

The ranges, if different from the nominal one, to be selected to avoid any restrictive operating rule(s) linked to environmental conditions, are specified by the Member States and are listed in Section 7.4.

The unit and its constituents shall be designed under consideration of one or several of the following external air temperature ranges:

- T1: – 25 °C to + 40 °C (nominal),
- T2: – 40 °C to + 35 °C, and
- T3: – 25 °C to + 45 °C.

The unit shall meet the requirements of this TSI without degradation for snow, ice and hail conditions as defined in clause 4.7 of ► **M3** EN 50125-1:2014 ◀, which correspond to the nominal range.

Where more severe ‘snow, ice and hail’ conditions than considered in the standard are selected, the unit and its constituents shall then be designed to meet TSI requirements considering the combined effect with low temperature according to the temperature range chosen.

In relation with the temperature range T2 and with the severe conditions for snow, ice and hail, the provisions taken to meet TSI requirements in these severe conditions shall be identified and verified, in particular design and/or testing provisions considering the following functions:

- Coupling function restricted to the resiliency of couplings.
- Brake function, including brake equipment.

The demonstration of conformity is described in point 6.2.2.7.

4.2.6. *System protection*

4.2.6.1. *Fire safety*

4.2.6.1.1. *General*

All significant potential fire sources (high risk components) on the unit shall be identified. The fire safety aspects of the unit design shall be aimed at:

- preventing a fire from occurring,
- limiting the effects if a fire occurs.

The goods carried on the unit are not part of the unit and do not have to be taken into account in the conformity assessment.

4.2.6.1.2. *Functional and technical specification*

4.2.6.1.2.1. *Barriers*

In order to limit the effects of fire, fire barriers with integrity of at least 15 minutes shall be installed between the identified potential fire sources (high risk components) and the carried load.

The demonstration of conformity is described in point 6.2.2.8.1.

▼B

4.2.6.1.2.2. Materials

All permanent materials used on the unit shall have limited ignitability and flame spread properties, unless:

- the material is separated from all potential fire risks on the unit by a fire barrier and the safe application is supported by a risk assessment, or
- the component has a mass < 400 g, and is located within a horizontal distance of ≥ 40 mm and a vertical distance of ≥ 400 mm to other non-tested components.

The demonstration of conformity is described in point 6.2.2.8.2.

4.2.6.1.2.3. Cables

The selection and installation of electrical cables shall take into account their fire behaviour properties.

The demonstration of conformity is described in point 6.2.2.8.3.

4.2.6.1.2.4. Flammable liquids

The unit shall be provided with measures preventing a fire from occurring and spreading due to leakage of flammable liquids or gases.

The demonstration of conformity is described in point 6.2.2.8.4.

4.2.6.2. Protection against electrical hazards

4.2.6.2.1. *Protective measures against indirect contact (protective bonding)*

The impedance between vehicle body and the running rail shall be low enough to prevent hazardous voltages between them.

Units shall be bonded in accordance with the provisions as described in clause 6.4 of ►**M3** EN 50153:2014 ◀.

4.2.6.2.2. *Protective measures against direct contact*

The electrical installations and equipment of a unit shall be designed so as to protect persons from electric shock.

The unit shall be designed so that direct contact is prevented following the provisions set out in clause 5 of ►**M3** EN 50153:2014 ◀.

4.2.6.3. Attachment devices for rear-end signal

▼M1

On all units designed to receive a rear-end signal, two devices at the end of the unit shall provide for the installation of two lamps or two reflective plates as set out in Appendix E at the same height above rail and not higher than 2 000 mm. The dimensions and clearance of these attachment devices shall be as described in ►**M3** Figure 11 of EN 16116-2:2013 ◀.

▼B4.3. **Functional and technical specification of the interfaces**4.3.1. *Interface with the subsystem 'infrastructure'*

Table 5

Interface with infrastructure subsystem

Reference in this TSI	Reference Commission Decision 2011/275/EU (*)
4.2.3.1 Gauging	4.2.4.1 Minimum structure gauge 4.2.4.2 Distance between track centres 4.2.4.5 Minimum radius of vertical curve
4.2.3.2 Compatibility with load carrying capacity of lines	4.2.7.1 Track resistance to vertical loads 4.2.7.3 Lateral track resistance 4.2.8.1 Resistance of bridges to traffic loads 4.2.8.2 Equivalent vertical loading for earthworks and earth pressure effects 4.2.8.4 Resistance of existing bridges and earthworks to traffic loads
4.2.3.5.2 Running dynamic behaviour	4.2.9 Track geometrical quality
4.2.3.6.2 Characteristics of wheelsets 4.2.3.6.3 Characteristics of wheels	4.2.5.1 Nominal track gauge 4.2.5.6 Rail head profile for plain line 4.2.6.2 In service geometry of switches and crossings

(*) OJ L 126, 14.5.2011, p. 53.

4.3.2. *Interface with the subsystem 'operation and traffic management'*

Table 6

Interface with operation and traffic management subsystem

Reference in this TSI	Reference Commission Decision 2011/314/EU (*)
4.2.2.2 Strength of unit — Lifting and jacking	4.2.3.6.3 Contingency arrangements
4.2.3.1 Gauging	4.2.2.5 Train composition
4.2.3.2 Compatibility with load carrying capacity of lines	4.2.2.5 Train composition
4.2.4 Brake	4.2.2.6 Train braking
4.2.6.3 Attachment devices for rear-end signal. Appendix E Rear-end signal	4.2.2.1.3.2 Rear-end

(*) OJ L 144, 31.5.2011, p. 1.

▼ B4.3.3. *Interface with the subsystem 'control, command and signalling'*

Table 7

Interface with control, command and signalling subsystem**▼ M1**

Reference in this TSI	► M3 Reference ERA/ERTMS/033281 rev. 4.0 ◀
4.2.3.3 a) Rolling stock characteristics compatible with train detection system based on track circuits	<ul style="list-style-type: none"> — axle distances (3.1.2.1, 3.1.2.4, 3.1.2.5 and 3.1.2.6), — vehicle axle load (3.1.7.1), — impedance between wheels (3.1.9), — use of composite brake blocks (3.1.6).
4.2.3.3 b) Rolling stock characteristics compatible with train detection system based on axle counters	<ul style="list-style-type: none"> — axle distances (3.1.2.1, 3.1.2.2, 3.1.2.5 and 3.1.2.6), — wheel geometry (3.1.3.1-3.1.3.4), — metal/inductive components-free space between wheels (3.1.3.5) — wheel material (3.1.3.6).
4.2.3.3 c) Rolling stock characteristics compatible with train detection system based on loop equipment	<ul style="list-style-type: none"> — vehicle metal construction (3.1.7.2).

▼ M34.4. **Operating rules**

Operating rules are developed within the procedures described in the railway undertaking safety management system. These rules take into account the documentation related to operation which forms a part of the technical file as required in Article 15(4) of and as set out in Annex IV to Directive (EU) 2016/797.

For the safety critical components (see also 4.5), the specific operational and operational traceability requirements are developed by the designers/manufacturers at design phase and through a collaboration between designers/manufacturers and the concerned railway undertakings or the concerned wagon keeper after vehicles have entered into operation.

The documentation related to operation describes the characteristics of the unit in relation to the design operating state to be considered in order to define the operating rules in normal and in various reasonably foreseeable degraded modes.

The documentation related to operation is composed of:

- a description of operation in normal mode, including the operational characteristics and limitations of the unit (e.g. vehicle gauge, maximum design speed, axle loads, brake performance, compatibility with train detection systems, permitted environmental conditions, type(s) and operation of track gauge changeover facility(ies) the unit is compatible with),
- a description of operation in degraded mode (when equipment or functions described in this TSI suffer safety failures) as far as can reasonably be predicted, together with the related acceptable limits and operating conditions of the unit that could be experienced,

▼ **M3**

- a safety critical components list: The safety critical components list shall contain the specific operational and operational traceability requirements.

The applicant shall provide the initial version of the documentation related to operating rules. This documentation might be modified later in accordance with the corresponding Union legislation, taking into account the existing operating and maintenance conditions of the unit. The Notified Body shall verify only that the documentation on operation is provided.

4.5. **Maintenance rules**

Maintenance is a set of activities intended to keep a functional unit in, or to restore it to a state in which it can perform its required function.

The following documents being part of the technical file as required in Article 15(4) of and as set out in Annex IV to Directive (EU) 2016/797 are necessary to undertake maintenance activities on the units:

- general documentation (point 4.5.1),
- the maintenance design justification file (point 4.5.2), and
- the maintenance description file (point 4.5.3).

The applicant shall provide the three documents described in 4.5.1, 4.5.2. and 4.5.3. This documentation might be modified later in accordance with the corresponding EU legislation, taking into account the existing operating and maintenance conditions of the unit. The Notified Body shall verify only that the documentation on maintenance is provided.

The applicant or any entity authorised by the applicant (e.g. a keeper) shall provide this documentation to the entity in charge of maintenance as soon as it is assigned for the maintenance of the unit.

On the basis of these three documents, the entity in charge of maintenance shall define a maintenance plan and appropriate maintenance requirements at maintenance operational level under its sole responsibility (not in the scope of the assessment against this TSI).

The documentation includes a list of safety critical components. Safety critical components are components for which a single failure has a credible potential to lead directly to a serious accident as defined in Article 3(12) of Directive (EU) 2016/798.

The safety critical components and their specific servicing, maintenance and maintenance traceability requirements are identified by the designers/manufacturers at design phase and through a collaboration between designers/manufacturers and the concerned entities in charge of maintenance after vehicles have entered into operation.

4.5.1. *General documentation*

The general documentation comprises of:

- Drawings and description of the unit and its components.
- Any legal requirement concerning the maintenance of the unit.
- Drawing of systems (electrical, pneumatic, hydraulic and control-circuit diagrams).

▼ **M3**

- Additional on-board systems (description of the systems including description of functionality, specification of interfaces and data processing and protocols).
- Configuration files for each vehicle (parts list and bill of material) to enable (in particular but not only) traceability during maintenance activities.

4.5.2. *Maintenance design justification file*

The maintenance design justification file explains how maintenance activities are defined and designed in order to ensure that the rolling stock characteristics will be kept within permissible limits of use during its lifetime. The file shall give input data in order to determine the criteria for inspection and the periodicity of maintenance activities. The maintenance design justification file consists of:

- Precedents, principles and methods used to design the maintenance of the unit.
- Precedents, principles and methods used to identify the safety critical components and their specific operational, servicing, maintenance and traceability requirements.
- Limits of the normal use of the unit (e.g. km/month, climatic limits, foreseen types of loads, etc.).
- Relevant data used to design the maintenance and origin of these data (return of experience).
- Tests, investigations and calculations carried out to design the maintenance.

4.5.3. *Maintenance description file*

The maintenance description file describes how maintenance activities can be conducted. Maintenance activities include, among others, inspections, monitoring, tests, measurements, replacements, adjustments and repairs.

Maintenance activities are split into:

- preventive maintenance (scheduled and controlled), and
- corrective maintenance.

The maintenance description file includes the following:

- Component hierarchy and functional description which sets up the boundaries of the rolling stock by listing all the items belonging to the product structure of that rolling stock and using an appropriate number of discrete levels. The lowest item of the hierarchy shall be a replaceable component.
- Parts list which shall contain the technical and functional descriptions of the spare parts (replaceable units). The list shall include all parts specified for changing based on condition, which may require a replacement following electrical or mechanical malfunction or which will foreseeable require a replacement after an accidental damage. Interoperability constituents shall be indicated and referenced to their corresponding declaration of conformity.
- Safety critical components list: The safety critical components list shall contain the specific servicing, maintenance and servicing/maintenance traceability requirements.

▼ M3

- Limit values for components which are not to be exceeded in service. It is permitted to specify operational restrictions in degraded mode (limit value reached).
- List of reference to the European legal obligations to which components or subsystems are subject.
- Maintenance plan ⁽¹⁾ i.e. the structured set of tasks to perform the maintenance including the activities, procedures and means. The description of this set of tasks includes:
 - (a) Disassembly/assembly instructions drawings necessary for correct assembly/disassembly of replaceable parts.
 - (b) Maintenance criteria.
 - (c) Checks and tests in particular of safety relevant parts; these include visual inspection and non-destructive tests (where appropriate e.g. to detect deficiencies that may impair safety).
 - (d) Tools and materials required to undertake the task.
 - (e) Consumables required to undertake the task.
 - (f) Personal protective safety provision and equipment.
- Necessary tests and procedures to be undertaken after each maintenance operation before re-entry into service of rolling stock.

▼ B**4.6. Professional competencies**

The professional competencies of staff required for the operation and maintenance of units are not covered by this TSI.

4.7. Health and safety conditions**▼ M1**

The provisions for health and safety of staff required for the operation and maintenance of units are covered by essential requirements 1.1.5, 1.3.1, 1.3.2, 2.5.1 and 2.6.1 set out in Annex III to ► **M3** Directive (EU) 2016/797 ◀.

▼ B

In particular, the following points of Section 4.2 specify provisions for health and safety of staff:

point 4.2.2.1.1: End coupling,

point 4.2.6.1: Fire safety,

point 4.2.6.2: Protection against electrical hazards.

If the unit is fitted with a manual coupling system, a free space for shunters during coupling and uncoupling shall be provided.

All protruding parts deemed a hazard to operational staff shall be clearly indicated and/or fitted with protective devices.

⁽¹⁾ The maintenance plan shall take into accounts the findings of the ERA Task force on Freight Maintenance (see 'Final report on the activities of the Task Force Freight Wagon Maintenance' published on the ERA website <http://www.era.europa.eu>).

▼B

The unit shall be equipped with footsteps and handrails except in those cases it is not intended to be operated with staff on-board, e.g. for shunting.

▼M1

4.8. **Parameters to be recorded in the technical file and European register of authorised types of vehicles**

▼B

The technical file shall contain at least the following parameters:

- Type, position and resiliency of the end coupling
- Load due to dynamic traction forces and compressive forces
- Gauge reference profiles to which the unit complies
- Conformity, if any, to target gauge reference profile(s) G1, GA, GB and GC
- Compliance, if any, to gauge lower reference profile(s)
 - ▶ **M3** G11 and G12 ◀
- Mass per axle (tare and fully laden)
- Position of the axles along the unit and number of axles
- Length of the unit
- Maximum design speed
- Track gauges(s) the unit can be operated on
- Compatibility with train detection systems (track circuits/axle counters/loop equipment)
- Compatibility with hot axle box detection systems
- In-service temperature range of the axle bearings
- Nature of the signal which controls the brake (example: pneumatic main brake pipe, electric brake type XXX, etc.)
- Characteristics of the control line and of its coupling with other units (main brake pipe diameter, section of the electric cable etc.)
- Individual nominal performance of the brake unit, depending on the brake mode, if any (response time, brake force, level of adhesion required, etc.)
- Braking distance or brake weight depending on the brake mode, if any

▼M1

- Thermal load of the brake components expressed in terms of speed, axle load, gradient and brake distance

▼B

- Temperature range and severity level of snow/ice/hail conditions
- Brake weight and maximum gradient of the parking brake (if applicable)
- Ability/inability to be hump shunted
- Presence of footsteps and/or handrails.

▼ M1

The rolling stock data that must be recorded in the ‘European register of authorised types of vehicles (ERATV)’ are set out in the Commission Implementing Decision 2011/665/EU of 4 October 2011 on the European register of authorised types of railway vehicles ⁽¹⁾.

▼ M34.9. **Route compatibility checks before the use of authorised vehicles**

The parameters of the subsystem ‘rolling stock — freight wagons’ to be used by the railway undertaking, for the purpose of route compatibility check, are described in Appendix D1 of Commission Implementing Regulation (EU) 2019/773 ⁽²⁾

▼ B

5. INTEROPERABILITY CONSTITUENTS

5.1. **General**

Interoperability constituents (ICs), as defined in Article 2(f) of ► **M3** Directive (EU) 2016/797 ◀, are listed in Section 5.3 together with:

- their area of use covering parameters of the subsystem, and
- the reference to corresponding requirements defined in Section 4.2.

When a requirement is identified in Section 5.3 as being assessed at IC level, an assessment for the same requirement at subsystem level is not required.

▼ M25.2. **Innovative solutions**

As stated in Article 10a, innovative solutions may require new specifications and/or new assessment methods. Such specifications and assessment methods shall be developed using the process described in point 6.1.3 whenever an innovative solution is envisaged for an interoperability constituent.

▼ B5.3. **Interoperability constituent specifications**5.3.1. *Running gear***▼ M3**

The running gear shall be designed for all application ranges, the areas of use, as defined by the following parameters:

- Track gauge

▼ B

- Maximum speed
- Maximum cant deficiency
- Minimum tare of the unit
- Maximum axle load
- Range of distances between bogie pivots or range of wheelbase of ‘two-axle units’
- Maximum height of centre of gravity of empty unit

⁽¹⁾ OJ L 264, 8.10.2011, p. 32.

⁽²⁾ Commission Implementing Regulation (EU) 2019/773 of 16 May 2019 on the technical specification for interoperability relating to the operation and traffic management subsystem of the rail system within the European Union and repealing Decision 2012/757/EU (OJ L 139 I, 27.5.2019, p. 5).

▼ B

- Coefficient of height of centre of gravity of loaded unit
- Minimum torsional stiffness coefficient of car body
- Maximum mass distribution coefficient for empty units with:

$$\frac{1}{2a^*} \cdot \sqrt{\frac{I_{zz}}{m}}$$

Where:

I_{zz} = moment of inertia of the car body relative to the vertical axis through the centre of gravity of the car body

m = mass of the car body

$2a^*$ = wheelbase

- Minimum nominal wheel diameter
- Rail inclination.

The parameters speed and axle load may be considered in combination in order to define the appropriate area of use (e.g. maximum speed and tare weight).

The running gear shall comply with the requirements expressed in points 4.2.3.5.2 and 4.2.3.6.1. These requirements shall be assessed at IC level.

5.3.2. *Wheelset***▼ M3**

For the purpose of this TSI, wheelsets include the main parts ensuring the mechanical interface with the track (wheels and connecting elements: e.g. transverse axle, independent wheel axle). Accessories parts (axle bearings, axle boxes and brake discs) are assessed at subsystem level.

The wheelset shall be assessed and designed for the area of use as defined by:

- track gauge,

▼ B

- nominal wheel tread diameter, and
- maximum vertical static force.

A wheelset shall comply with the requirements on geometrical and mechanical parameters defined in point 4.2.3.6.2. These requirements shall be assessed at IC level.

5.3.3. *Wheel*

A wheel shall be designed and assessed for an area of use defined by:

- nominal tread diameter,
- maximum vertical static force,

▼ M3

- maximum speed,
- in-service limits, and

▼ B

- maximum braking energy.

A wheel shall comply with the requirements on geometrical, mechanical and thermo mechanical parameters defined in point 4.2.3.6.3. These requirements shall be assessed at IC level.

▼ B5.3.4. *Axle*

An axle shall be designed and assessed for an area of use defined by:

- maximum vertical static force.

An axle shall comply with the requirements on mechanical parameters defined in point 4.2.3.6.4. These requirements shall be assessed at IC level.

▼ M25.3.4a. *Friction element for wheel tread brakes*

The friction element for wheel tread brakes shall be designed and assessed for an area of use defined by:

- dynamic friction coefficients and their tolerance bands,
- minimum static friction coefficient,
- maximum permitted brake forces applied on the element,
- suitability for train detection by systems based on track circuits,
- suitability for severe environmental conditions.

A friction element for wheel tread brakes shall comply with the requirements defined in point 4.2.4.3.5. These requirements shall be assessed at IC level.

▼ M35.3.4b. *Automatic variable gauge system*

An IC 'automatic variable gauge system' shall be designed and assessed for an area of use defined by:

- the track gauges the system is designed for,
- the range of maximum static axle loads,
- the range of nominal wheel tread diameters,
- the maximum design speed of the unit, and
- the types of track gauge changeover facility(ies) the system is designed for, including the nominal speed through the track changeover facility(ies) and the maximum axial forces during the automatic gauge changeover process.

An automatic variable gauge system shall comply with the requirements set out in point 4.2.3.6.6; these requirements shall be assessed at IC level as set out in point 6.1.2.6.

▼ B5.3.5. *Rear-end signal*

The rear-end signal, as described in Appendix E, is an independent IC. There are no requirements in Section 4.2 dealing with the rear-end signal. Its assessment by the notified body is not part of the EC verification of the subsystem.

6. CONFORMITY ASSESSMENT AND EC VERIFICATION

6.1. **Interoperability constituent**6.1.1. *Modules*

The conformity assessment of an interoperability constituent shall be performed in accordance with the module(s) described in Table 8.

▼ B

Table 8

Modules for conformity assessment of interoperability constituents

Module CA1	Internal production control plus product verification by individual examination
Module CA2	Internal production control plus product verification at random intervals
Module CB	EC-Type examination
Module CD	Conformity to type based on quality management system of the production process
Module CF	Conformity to type based on product verification
Module CH	Conformity based on full quality management system
Module CH1	Conformity based on full quality management system plus design examination
Module CV	Type validation by in-service experience (suitability for use)

▼ M2**▼ B**

These modules are specified in detail in Decision 2010/713/EU.

6.1.2. *Conformity assessment procedures*

The manufacturer or his authorised representative established within the Union shall choose one of the modules or module combinations indicated in Table 9 in accordance with the required constituent.

▼ M2

Table 9

Modules to be applied for interoperability constituents

Point	Constituent	Modules					
		CA1 or CA2	CB + CD	CB + CF	CH	CH1	CV
4.2.3.6.1	Running gear		X	X		X	
	Running gear — established	X			X		
4.2.3.6.2	Wheelset	X (*)	X	X	X (*)	X	
4.2.3.6.3	Wheel	X (*)	X	X	X (*)	X	
4.2.3.6.4	Axle	X (*)	X	X	X (*)	X	
4.2.3.6.6	Automatic variable gauge system	X (*)	X	X	X (*)	X	X (**)
4.2.4.3.5	Friction element for wheel tread brakes	X (*)	X	X	X (*)	X	X (**)

▼ M3**▼ M2**

▼ M2

Point	Constituent	Modules					
		CA1 or CA2	CB + CD	CB + CF	CH	CH1	CV
5.3.5	Rear-end signal	X			X		

(*) Modules CA1, CA2 or CH may be used only in the case of products placed on the market, and therefore developed, before the entry into force of this TSI, provided that the manufacturer demonstrates to the NoBo that design review and type examination were performed for previous applications under comparable conditions, and are in conformity with the requirements of this TSI; this demonstration shall be documented, and is considered as providing the same level of proof as module CB or design examination according to module CH1.

(**) Module CV shall be used in case the manufacturer of friction element for wheel tread brakes has no sufficient return of experience (according to its own judgment) for the proposed design.

▼ B

Within the application of the chosen module or module combination the interoperability constituent shall be assessed against the requirements mentioned in Section 4.2. If necessary, additional requirements concerning the assessment of particular interoperability constituents are given in the following clauses.

▼ M3

In case of a specific case applicable to a component defined as interoperability constituent in section 5.3 of this TSI, the corresponding requirement can be part of the verification at interoperability constituent level only in the case where the component remains compliant to the chapters 4 and 5 of this TSI and where the specific case does not refer to a national rule (i.e. additional requirement compatible with the core TSI and fully specified in the TSI).

In other cases, the verification shall be made at subsystem level; when a national rule applies to a component, the concerned Member State may define relevant applicable conformity assessment procedures.

6.1.2.1. **Running gear**

The demonstration of conformity for running dynamic behaviour is set out in EN 16235:2013.

Units equipped with an established running gear as described in chapter 6 of EN 16235:2013 are presumed to be in conformity with the relevant requirement provided that the running gears are operated within their established area of use.

The assessment of the bogie frame strength shall be based on clause 6.2 of EN 13749:2011.

▼ B6.1.2.2. **Wheelset**

The demonstration of conformity for the mechanical behaviour of the wheelset assembly shall be carried out according to clause 3.2.1 of EN 13260:2009+A1:2010, which defines limit values for the axial assembly force and the associated verification test.

▼ M3

A verification procedure shall exist to ensure at the assembly phase that no defects may detrimentally affect safety due to any change in the mechanical characteristics of the fitted parts of the axle. This procedure shall contain the determination of the interference values and, in case of press-fitted wheelsets, the corresponding press-fitting diagram.

▼ B

6.1.2.3. Wheel

- (a) Forged and rolled wheels: The mechanical characteristics shall be proven following the procedure as specified in clause 7 of EN 13979-1:2003+A1:2009+A2:2011.

If the wheel is intended to be used with brake blocks acting on the wheel running surface, the wheel shall be thermo mechanically proven by taking into account the maximum braking energy foreseen. A type test, as described in clause 6.2 of EN 13979-1:2003+A1:2009+A2:2011 shall be performed in order to check that the lateral displacement of the rim during braking and the residual stress are within the specified tolerance limits.

The decision criteria of residual stresses for forged and rolled wheels are set out in EN 13979-1:2003+A1:2009+A2:2011.

- (b) Other types of wheels: Other types of wheels are permitted for units in national use. In that case the decision criteria and the fatigue stress criteria shall be specified in national rules. Those national rules shall be notified by Member States in accordance with Article 17(3) of ►**M3** Directive (EU) 2016/797 ◀.

▼ M1

A verification procedure shall exist to ensure at the production phase that no defects may adversely affect safety due to any change in the mechanical characteristics of the wheels. The tensile strength of the material in the wheel, the hardness of the rim, the fracture toughness (only for tread-braked wheels), the resistance to impact, the material characteristics and the material cleanliness shall be verified. The verification procedure shall specify the batch sampling used for each characteristic to be verified.

▼ B

6.1.2.4. Axle

▼ M1

In addition to the requirement for the assembly above, the demonstration of conformity of the mechanical resistance and fatigue characteristics of the axle shall be based on Clauses 4, 5 and 6 of EN13103:2009 + A2:2012.

The decision criteria for the permissible stress are specified in Clause 7 of EN EN13103:2009 + A2:2012. A verification procedure shall exist to ensure at the production phase that no defects may adversely affect safety due to any change in the mechanical characteristics of the axles. The tensile strength of the material in the axle, the resistance to impact, the surface integrity, the material characteristics and the material cleanliness shall be verified. The verification procedure shall specify the batch sampling used for each characteristic to be verified.

▼ M2

6.1.2.5. Friction elements for wheel tread brakes

The demonstration of conformity of friction elements for wheel tread brakes shall be carried out by determining the following friction element properties in accordance with the European Railway Agency (ERA) technical document ►**M3** ERA/TD/2013-02/INT version 3.0 of 27.11.2015 ◀ published on the ERA website (<http://www.era.europa.eu>):

— dynamic friction performance (chapter 4);

▼ M2

- static friction coefficient (chapter 5);
- mechanical characteristics including properties in respect to shear strength test and flexural strength test (chapter 6).

Demonstration of the following suitabilities shall be carried out in accordance with chapters 7 and/or 8 of the ERA technical document ► **M3** ERA/TD/2013-02/INT version 3.0 of 27.11.2015 ◀ published on the ERA website (<http://www.era.europa.eu>), if the friction element is intended to be suitable for:

- train detection by systems based on track circuits; and/or
- severe environmental conditions.

If a manufacturer does not have sufficient return of experience (according with its own judgement) for the proposed design, the type validation by in-service experience procedure (module CV) shall be part of the assessment procedure for suitability for use. Before commencing in-service tests, a suitable module (CB or CH1) shall be used to certify the design of the interoperability constituent.

The in-service tests shall be organised on request from the manufacturer, who must obtain agreement from a railway undertaking that will contribute to such an assessment.

The suitability for train detection by systems based on track circuits for friction elements intended to be used in subsystems beyond the scope set out in chapter 7 of the ERA technical document ► **M3** ERA/TD/2013-02/INT version 3.0 of 27.11.2015 ◀ published on the ERA website (<http://www.era.europa.eu>) may be demonstrated using the procedure for innovative solutions described in point 6.1.3.

The suitability for severe environmental conditions by a dynamometer test for friction elements intended to be used in subsystems beyond the scope set out in clause 8.2.1 of the ERA technical document ► **M3** ERA/TD/2013-02/INT version 3.0 of 27.11.2015 ◀ published on the ERA website (<http://www.era.europa.eu>) may be demonstrated using the procedure for innovative solutions described in point 6.1.3.

▼ M3

6.1.2.6. Automatic variable gauge system

The assessment procedure shall be based on a validation plan covering all aspects mentioned in points 4.2.3.6.6 and 5.3.4b.

The validation plan shall be consistent with the safety analysis required in clause 4.2.3.6.6 and shall define the assessment needed in all the following different phases:

- Design review
- Static tests (bench tests and integration-in-the-wheelset/unit tests)
- Test on track gauge changeover facility(ies), representative of in-service conditions
- On-track tests, representative of in-service conditions.

▼ M3

Regarding the demonstration of compliance to the safety level required in point 4.2.3.6.6, the assumptions considered for the safety analysis related to the unit the system is intended to be integrated in, and related to the mission profile of that unit, shall be clearly documented.

The automatic variable gauge system may be subject to an assessment of suitability for use (module CV). Before commencing in-service tests, a suitable module (CB or CH1) shall be used to certify the design of the interoperability constituent. The in-service tests shall be organised on request from the manufacturer, who must obtain an agreement from a railway undertaking for its contribution to such assessment.

The certificate delivered by the notified body in charge of the conformity assessment shall include both the conditions for use as per clause 5.3.4b and the type(s) and operating conditions of the track gauge changeover facility(ies) the automatic variable gauge system has been assessed for.

▼ M26.1.3. *Innovative solutions*

If an innovative solution referred to in Article 10a is proposed for an interoperability constituent, the manufacturer or his authorised representative established within the Union shall apply the procedure set out in Article 10a.

▼ B6.2. **Subsystem**6.2.1. *Modules*

The EC verification of the subsystem 'Rolling stock — freight wagons' shall be performed in accordance with the module(s) described in Table 10.

Table 10

Modules for EC verification of subsystems

SB	EC-Type Examination
SD	EC verification based on quality management system of the production process
SF	EC verification based on product verification
SH1	EC verification based on full quality management system plus design examination

These modules are specified in detail in Decision 2010/713/EU.

6.2.2. *EC verification procedures*

The applicant shall choose one of the following combinations of modules or module for the EC verification of the subsystem:

— (SB+SD), or

— (SB+SF), or

— (SH1).

▼ B

Within the application of the chosen module or module combination the subsystem shall be assessed against the requirements mentioned in Section 4.2. If necessary, additional requirements concerning the assessment of particular constituents are given in the following clauses.

6.2.2.1. Strength of unit

▼ M3

The demonstration of conformity shall be in accordance with chapters 6 and 7 of EN 12663-2:2010, or alternatively with chapter 9.2 of EN 12663-1:2010+A1:2014.

▼ B

Regarding joints, a recognised verification procedure shall exist to ensure at the production phase that no defect may decrease the intended mechanical characteristics of the structure.

▼ M3

6.2.2.2. Safety against derailment running on twisted track

The demonstration of conformity shall be carried out in accordance with chapters 4, 5 and 6.1 of EN 14363:2016.

6.2.2.3. Running dynamic behaviour

On-track tests

The demonstration of conformity shall be carried out in accordance with chapters 4, 5 and 7 of EN 14363:2016.

For units operated on the 1 668 mm track gauge network, the evaluation of the estimated value for the guiding force normalized to the radius $R_m = 350$ m according to EN 14363:2016, clause 7.6.3.2.6 (2), shall be calculated according to the following formula:

$$Y_{a,nf,qst} = Y_{a,f,qst} - (11\,550 \text{ m}/R_m - 33) \text{ kN.}$$

The limit value of the quasi-static guiding force $Y_{j,a,qst}$ shall be 66 kN.

Values of cant deficiency can be adapted to 1 668 mm track gauge by multiplying the corresponding 1 435 mm parameter values by the following conversion factor: 1 733/1 500.

The combination of the highest equivalent conicity and speed for which the unit meets the stability criterion in chapters 4, 5 and 7 of EN 14363:2016 shall be recorded in the report.

▼ B

6.2.2.4. Axle box/bearings

The demonstration of conformity for mechanical resistance and fatigue characteristics of the rolling bearing shall be in accordance with clause 6 of EN 12082:2007+A1:2010.

▼ M3

It is permitted to use other standards for the above demonstration of conformity where the EN standards do not cover the proposed technical solution; in that case the notified body shall verify that the alternative standards form part of a technically consistent set of standards applicable to the design, construction and testing of the bearings.

Only standards that are publicly available can be referred to in the demonstration required above.

▼ M3

In the case of bearings manufactured according to a design developed and already used to place products on the market before the entry into force of relevant TSIs applicable to those products, the applicant is allowed to deviate from the demonstration of conformity above and refer to design review and type examination performed for previous applications under comparable conditions instead; this demonstration shall be documented and is considered as providing the same level of proof as type examination according to module SB or design examination according to module SH1.

6.2.2.4a. Automatic variable gauge systems

The safety analysis required in point 4.2.3.6.6, and performed at IC level, shall be consolidated at the level of the unit; in particular, the assumptions made in accordance with point 6.1.2.6 may need to be reviewed to take into account the unit and its mission profile.

▼ B

6.2.2.5. Running gear for manual change of wheelsets

Changeover between 1435 mm and 1668 mm track gauges

▼ M1

The technical solutions described in the following figures of UIC leaflet 430-1:2012 are deemed to be compliant with the requirements in point 4.2.3.6.7:

— for axle units: Figures 9 and 10 of Annex B.4, and Figure 18 of Annex H of UIC leaflet 430-1:2012,

— ► **M3** for bogie units: Figure 18 of Annex H and Figures 19 and 20 of Annex I of UIC leaflet 430-1:2012. ◀

▼ B

Changeover between 1435 mm and 1524 mm track gauges

The technical solution described in Appendix 7 of UIC leaflet 430-3:1995 is deemed to be compliant with the requirements in point 4.2.3.6.7.

6.2.2.6. Thermal capacity

Calculations, simulations or tests shall demonstrate that the temperature of the brake block, brake pad or brake disc does not exceed their thermal capacity. The following shall be taken into account:

(a) concerning the emergency brake application: the critical combination of speed and payload considering straight and level track, minimum wind and dry rails;

(b) concerning the continuous brake application:

— the range up to the maximum braking power,

— the range up to the maximum speed, and

— the corresponding brake application time.

6.2.2.7. Environmental conditions

Steel materials are deemed to comply with all the ranges indicated in point 4.2.5 if the material properties are determined down to -20 °C .

▼B

6.2.2.8. Fire safety

6.2.2.8.1. *Barriers*

Barriers shall be tested in accordance with ►**M3** EN 1363-1:2012 ◀. Steel sheets of at least 2 mm thickness and aluminium sheets of at least 5 mm thickness are deemed to comply with the integrity requirements without testing.

6.2.2.8.2. *Materials***▼M3**

Testing of the materials ignitability and flame spread properties shall be performed in accordance with ISO 5658-2:2006/Am1:2011 for which the limit value shall be $CFE \geq 18 \text{ kW/m}^2$.

For rubber parts of bogies, the testing shall be performed in accordance with ISO 5660-1:2015 for which the limit value shall be $MARHE \leq 90 \text{ kW/m}^2$ under the test conditions specified in reference T03.02 of Table 6 of EN 45545-2:2013+A1:2015.

For the following materials and components the fire safety requirements are deemed to comply with the required ignitability and flame spread properties:

— Wheelsets, coated or uncoated,

▼B

— metals and alloys with inorganic coatings (such as, but not limited to: galvanised coating, anodic coating, chromate film, phosphate conversion coating),

— metals and alloys with an organic coating with a nominal thickness less than 0,3 mm (such as, but not limited to paints, plastic coating, asphaltic coating),

— metals and alloys with a combined inorganic and organic coating of which the nominal thickness of the organic layer is less than 0,3 mm,

— glass, stoneware, ceramic and natural stone products,

— materials that meet the requirements of category C-s3, d2 or higher in accordance with EN 13501-1:2007+A1:2009.

6.2.2.8.3 *Cables*

The electrical cables shall be selected and installed in accordance with ►**M3** EN 50355:2013 ◀ and ►**M3** EN 50343:2014 ◀.

6.2.2.8.4 *Flammable liquids*

The measures taken shall be in accordance with ►**M3** EN 45545-7:2013 ◀.

▼M26.2.3. *Innovative solutions*

If an innovative solution referred to in Article 10a is proposed for the ‘rolling stock — freight wagons’ subsystem, the applicant shall apply the procedure set out in Article 10a.

▼B6.3. **Subsystem containing components corresponding to interoperability constituents not holding an EC declaration****▼M1**

A Notified Body is permitted to issue an EC certificate of verification of a subsystem, even if one or more of the components corresponding to interoperability constituents incorporated within the subsystem are not covered by a relevant EC declaration of conformity in accordance with this TSI (non-certified ICs), if the constituent was manufactured before the entry into force of this TSI and the type of constituent has been:

— used in a subsystem already approved, and

▼ M1

- placed in service in at least one Member State before the entry in force of this TSI.

▼ B

The EC verification of the subsystem shall be carried out by the notified body against the requirements of Chapter 4 by using the corresponding requirements concerning assessment in Chapter 6 together with Chapter 7 except for specific cases. For this EC verification the modules of the subsystem, set out in point 6.2.2, apply.

EC declarations of conformity or suitability for use shall not be drawn up for the components assessed in this manner.

6.4. Project phases where assessment is required

The assessment shall cover the following two phases as identified by 'X' in the Table F.1 of Appendix F in this TSI. In particular, where a type test is identified the conditions and requirements of Section 4.2 shall be considered.

(a) Design and development phase:

- Design review and/or design examination
- Type test: test to verify the design, if and as defined in the Section 4.2.

(b) Production phase:

- Routine test to verify the conformity of production. The entity in charge of the assessment of the routine tests is determined according to the assessment module chosen.

Appendix F is structured according to Section 4.2. Where relevant, a reference to the points of Sections 6.1 and 6.2 is given.

6.5. Constituents holding an EC declaration of conformity

Where a constituent has been identified as an IC and held an EC declaration of conformity before the entry into force of this TSI, its treatment under this TSI is set out as follows:

- (a) In the case this constituent is not recognised as an IC in this TSI, neither the certificate nor the declaration are valid for the EC verification procedure related to this TSI.

▼ M1

- (b) The EC certificates of conformity, EC-type examination certificates and EC-design examination certificates of the following ICs shall remain valid under this TSI until their expiry:
- Wheelset;
 - Wheel;
 - Axle.

▼ B

7. IMPLEMENTATION

▼ M37.1. **Authorisation for placing on the market**

This TSI is applicable to the subsystem ‘rolling stock — freight wagons’ within the scope set out in its Sections 1.1, 1.2 and 2.1, which are placed on the market after the date of application of this TSI.

This TSI is also applicable on a voluntary basis to:

- units referred to in section 2.1 point (a) in transport (running) configuration, in case they correspond to a ‘unit’ as defined in this TSI, and
- units as defined in section 2.1 point (c), in case they are in empty configuration.

In case the applicant chooses to apply this TSI, the corresponding EC declaration of verification shall be recognised as such by Member States.

▼ B7.1.1. *Authorisation for placing in service of a new vehicle in conformity with the previous WAG TSIs⁽¹⁾*

See Article 9.

▼ M37.1.2. *Mutual recognition of the first authorisation of placing on the market*

In accordance with Article 21(3)(b) of Directive (EU) 2016/797 the authorisation for placing of the market of a vehicle (as defined in this TSI) is granted on the basis of:

- in accordance with point (a) of Article 21(3): the ‘EC’ declaration of verification as provided for in Article 15 of the same directive, and
- in accordance with (d) of Article 21(3): evidence of the technical compatibility of the unit with the network in the area of use covering the EU network.

Points (b) and (c) of Article 21(3) of Directive (EU) 2016/797 do not represent any additional requirement. The technical compatibility of the vehicle with the network being covered by rules (TSIs or national rules), this aspect is also considered at the level of the ‘EC’ verification.

Therefore, the conditions for having an area of use not limited to particular national networks are specified below as additional requirements to be covered in the EC verification of the subsystem rolling stock. These conditions shall be seen as complementary to the requirements in Section 4.2 and must be fulfilled in their entirety:

- (a) The unit must be equipped with forged and rolled wheels assessed according to point 6.1.2.3(a).

⁽¹⁾ Commission Decision 2006/861/EC (OJ L 344, 8.12.2006, p.1) and Commission Decision 2006/861/EC amended by Commission Decision 2009/107/EC (OJ L 45, 14.2.2009, p.1).

▼ **M3**

- (b) The compliance/non-compliance with the requirements regarding the axle bearing condition monitoring by line side equipment as set out in point 7.3.2.2.(a) must be recorded in the technical file.
- (c) The reference profile established for the unit as per point 4.2.3.1 must be allocated to one of the target reference profile(s) G1, GA, GB and GC including those used for the lower part G11 and G12.
- (d) The unit must be compatible with the train detection systems based on track circuits, on axle counters and on loop equipment as specified in clauses 4.2.3.3(a), 4.2.3.3(b) and 4.2.3.3(c).
- (e) The unit must be equipped with the manual coupling system in accordance with the prescriptions set out in Appendix C, Section 1, including the fulfilment of Section 8 or with any semi-automatic or automatic standardised coupling system.
- (f) The brake system must be in accordance with the conditions of Appendix C, Sections 9, 14 and 15 when applying the reference case set out in point 4.2.4.2.
- (g) The unit must be marked with all applicable markings in accordance with EN 15877-1:2012, except the marking defined in its clause 4.5.25(b).
- (h) The parking brake force shall be marked as set out in Figure 1, 30 mm below the marking defined in clause 4.5.3 of EN 15877-1:

Figure 1

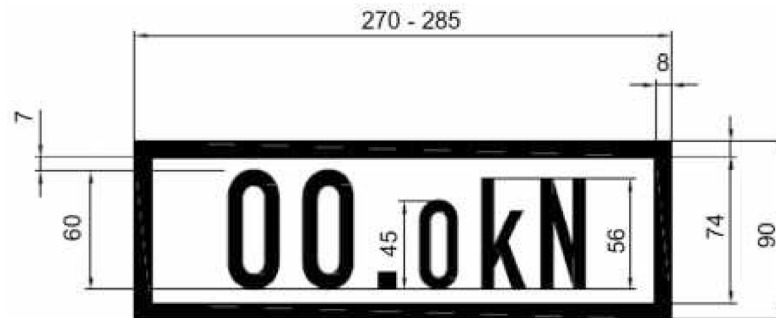
Marking of the parking brake force

When an international agreement to which the European Union is party provides for reciprocal legal provisions, units which have been authorised to operate according to said international agreement and comply with all requirements set out in section 4.2 and in this point 7.1.2 shall be deemed as authorised for placing on the market in the Member States of the European Union.

7.2. General rules for implementation

7.2.1. Substitution of constituents

This section deals with substitutions of constituents as referred to in Article 2 of Directive (EU) 2016/797.

The following categories have to be considered:

Certified ICs: Components which correspond to an IC in Chapter 5 and which are holding a certificate of conformity.

▼ **M3**

Other components: Any component, which is not corresponding to an IC in Chapter 5.

Non-certified ICs: Components which correspond to an IC in Chapter 5 but are not holding a certificate of conformity and which are produced before the expiry of the transitional period referred to in Section 6.3.

Table 11 shows the possible permutations.

Table 11

Substitution permutation table

	... substituted by ...		
	... certified ICs	... other components	... non-certified ICs
Certified ICs ...	Check	not possible	check
Other components ...	not possible	check	not possible
Non-certified ICs ...	Check	not possible	check

The word ‘check’ in Table 11 means that the entity in charge of maintenance (ECM) may under its responsibility substitute a component by another one utilising the same function and at least the same performance in accordance with the relevant TSI requirements considering that these components are:

- suitable, i.e. conform to the relevant TSI(s),
- used within its area of use,
- enabling interoperability,
- meeting the essential requirements, and
- in line with restrictions stated in the technical file.

7.2.2. *Changes to an existing unit or to an existing unit type*

7.2.2.1. **Introduction**

This point 7.2.2 defines the principles to be applied by the entities managing the change and authorising entities in line with the EC verification procedure described in Article 15(9), Article 21(12) and Annex IV of Directive (EU) 2016/797. This procedure is further developed in Article 13, 15 and 16 of Commission Implementing Regulation (EU) 2018/545 ⁽¹⁾ and in Commission Decision 2010/713/EC ⁽²⁾.

This point 7.2.2 applies in case of any change(s) to an existing unit or unit type, including renewal or upgrade. It does not apply in case of changes:

- that do not introduce a deviation from the technical files accompanying the EC declarations for verification for the subsystems, if any, and

⁽¹⁾ Commission Implementing Regulation (EU) 2018/545 of 4 April 2018 establishing practical arrangements for the railway vehicle authorisation and railway vehicle type authorisation process pursuant to Directive (EU) 2016/797 of the European Parliament and of the Council (OJ L 90, 6.4.2018, p. 66).

⁽²⁾ Commission Decision 2010/713/EU of 9 November 2010 on modules for the procedures for assessment of conformity, suitability for use and EC verification to be used in the technical specifications for interoperability adopted under Directive 2008/57/EC of the European Parliament and of the Council (OJ L 319, 4.12.2010, p. 1).

▼ **M3**

- that do not have an impact on basic parameters not covered by the EC declaration, if any.

The holder of the vehicle type authorisation shall provide, under reasonable conditions, the information necessary for assessing the changes to the entity managing the change.

7.2.2.2. Rules to manage changes in both a unit or a unit type

Parts and basic parameters of the unit that are not affected by the change(s) are exempt from conformity assessment against the provisions in this TSI.

Without prejudice to clause 7.2.2.3, compliance with the requirements of this TSI or the TSI Noise (Commission Regulation (EU) No 1304/2014 ⁽¹⁾), see clause 7.2 of that TSI) shall only be needed for the basic parameters in this TSI which may be affected by the change(s).

In accordance with Articles 15 and 16 of Commission Implementing Regulation (EU) 2018/545 and Decision 2010/713/EU and by application of modules SB, SD/SF or SH1 for the EC verification, and if relevant in accordance with Article 15(5) of Directive (EU) 2016/797, the entity managing the change shall inform a notified body of all changes affecting the conformity of the subsystem with requirements of the relevant TSI(s) requiring new checks by a notified body. This information shall be provided by the entity managing the change with corresponding references to the technical documentation relating to the existing EC type or design examination certificate.

Without prejudice of the general safety judgement mandated in article 21(12)(b) of Directive (EU) 2016/797, in case of changes requiring reassessment of the safety requirements set out in clauses 4.2.4.2 for the brake system, a new authorization for placing on the market will be required unless one of the following conditions are met:

- The brake system fulfils the conditions of C.9 and C.14 of Appendix C after change or,
- Both the original and changed brake systems fulfil the safety requirements set out in clause 4.2.4.2.

National migration strategies related to the implementation of other TSIs (e.g. TSIs covering fixed installations) shall be taken into account when defining to what extent the TSIs covering rolling stock needs to be applied.

The basic design characteristics of the rolling stock are defined in Table 11a. Based on these tables and on the safety judgement mandated in Article 21(12)(b) of Directive (EU) 2016/797, the changes shall be categorised as follows:

- 15(1)(c) of Commission Implementing Regulation (EU) 2018/545 if they are above the thresholds set out in column 3 and below thresholds set out in column 4 unless the safety judgement mandated in Article 21(12)(b) of Directive (EU) 2016/797 requires to categorise them as 15(1)(d), or

⁽¹⁾ Commission Regulation (EU) No 1304/2014 of 26 November 2014 on the technical specification for interoperability relating to the subsystem 'rolling stock — noise' amending Decision 2008/232/EC and repealing Decision 2011/229/EU (OJ L 356, 12.12.2014, p. 421).

▼ **M3**

- 15(1)(d) of Commission Implementing Regulation (EU) 2018/545 if they are above the thresholds set out in column 4 or if the safety judgement mandated in Article 21(12)(b) of Directive (EU) 2016/797 requires to categorise them as 15(1)(d).

The determination whether the changes are beyond or above the thresholds mentioned above shall be done in reference to the values of the parameters at the time of the last authorisation of the rolling stock or rolling stock type.

Changes not referred to in the paragraph above are deemed not to have any impact on the basic design characteristics and will be categorised as 15(1)(a) or 15(1)(b) of Commission Implementing Regulation (EU) 2018/545, unless the safety judgement mandated in Article 21(12)(b) of Directive (EU) 2016/797 requires to categorise them as 15(1)(d).

The safety judgement mandated in Article 21(12)(b) of Directive (EU) 2016/797 shall cover all changes concerning basic parameters of table 1, related to all the essential requirements, in particular the requirements ‘Safety’ and ‘Technical compatibility’.

Without prejudice to clause 7.2.2.3, all changes shall remain compliant with the applicable TSIs regardless their classification.

The replacement of a whole element within a rake of permanently connected elements after a severe damage does not require a conformity assessment against this TSI, as long as the element is identical to the one it replaces. Such element must be traceable and certified in accordance with any national or international rule, or any code of practice widely acknowledged in the railway domain.

Table 11a

Basic design characteristics related to basic parameters set out in the WAG TSI

1. TSI clause	2. Related basic design characteristic(s)	3. Changes impacting the basic design characteristic and not classified as 21(12)(a) of Directive (EU) 2016/797	4. Changes impacting the basic design characteristic and classified as 21(12)(a) of Directive (EU) 2016/797
4.2.2.1.1 End coupling	Type of end coupling	Change of end coupler type	N/A
4.2.3.1 Gauging	Reference profile	N/A	Change of reference profile the vehicle is conform to
	Minimum vertical convex curve radius capability	Change in minimum vertical convex curve radius capability the unit is compatible with of more than 10 %	N/A
	Minimum vertical concave curve radius capability	Change in minimum vertical concave curve radius capability the unit is compatible with of more than 10 %	N/A

▼ M3

1. TSI clause	2. Related basic design characteristic(s)	3. Changes impacting the basic design characteristic and not classified as 21(12)(a) of Directive (EU) 2016/797	4. Changes impacting the basic design characteristic and classified as 21(12)(a) of Directive (EU) 2016/797
4.2.3.2. Compatibility with load carrying capacity of lines	Permissible payload for different line categories	Change ⁽¹⁾ of any of the vertical loading characteristics resulting in a change of the line category(ies) the wagon is compatible with	N/A
4.2.3.3 Compatibility with train detection systems	Compatibility with train detection systems	N/A	Change of declared compatibility with one or more of the three train detection systems: Track circuits Axle counters Loop equipment
4.2.3.4 Axle bearing condition monitoring	On-board detection system	N/A	Fitting/Removal of on-board detection system
4.2.3.5 Running safety	Combination of maximum speed and maximum cant deficiency for which the unit was assessed	N/A	Increase in maximum speed of more than 15 km/h or change of more than $\pm 10\%$ in maximum admissible cant deficiency
	Rail inclination	N/A	Change of rail inclination the vehicle is conform to ⁽²⁾
4.2.3.6.2 Characteristics of wheelsets	Wheelset gauge	N/A	Change of track gauge the wheelset is compatible with
4.2.3.6.3 Characteristics of wheels	Minimum required in-service wheel diameter	Change of minimum required in-service diameter of more than 10 mm	N/A
4.2.3.6.6 Automatic variable gauge systems	Wheelset gauge changeover facility	Change in the unit leading to a change in the changeover facility(ies) the wheelset is compatible with	Change of track gauge(s) the wheelset is compatible with
4.2.4.3.2.1 Service brake	Stopping distance	Change of stopping distance of more than $\pm 10\%$ Note: Brake weight percentage (also called 'lambda' or 'braked mass percentage') or braked mass may also be used, and can be derived (directly or via stopping distance) from deceleration profiles by a calculation. The allowed change is the same ($\pm 10\%$)	N/A

▼ M3

1. TSI clause	2. Related basic design characteristic(s)	3. Changes impacting the basic design characteristic and not classified as 21(12)(a) of Directive (EU) 2016/797	4. Changes impacting the basic design characteristic and classified as 21(12)(a) of Directive (EU) 2016/797
	Maximum deceleration for the load condition 'maximum speed under normal payload at the maximum design speed	Change of more than $\pm 10\%$ on the maximum average brake deceleration	N/A
4.2.4.3.2.2 Parking brake	Parking brake	Parking brake function installed/removed	N/A
4.2.4.3.3 Thermal capacity	Thermal capacity expressed in terms of Speed Gradient Brake distance	N/A	New reference case declared
4.2.4.3.4 Wheel slide protection (WSP)	Wheel slide protection	N/A	Fitting/removal of WSP function
4.2.5 Environmental conditions	Temperature range	Change of temperature range (T1, T2, T3)	N/A
	Snow, ice and hail conditions	Change of the selected range 'snow, ice and hail' (nominal or severe)	N/A

(1) Change of the loading characteristics is not to be re-assessed in operation (loading/unloading of the wagon)

(2) The rolling stock fulfilling one of the following conditions are deemed to be compatible with all rail inclinations:

- Rolling stock assessed according to EN 14363:2016
- Rolling stock assessed according to EN 14363:2005 (amended or not amended by ERA/TD/2012-17/INT) or UIC 518:2009 with the result, that there is no restriction to one rail inclination
- vehicles assessed according to EN 14363:2005 (amended or not amended by ERA/TD/2012-17/INT) or UIC 518:2009 with the result, that there is a restriction to one rail inclination and a new assessment of the wheel-rail-contact test conditions based on real wheel- and rail profiles and measured track gauge show compliance with the requirements on wheel-rail-contact conditions of EN 14363:2016

In order to establish the EC type or design examination certificate, the notified body selected by the entity managing the change is permitted to refer to:

The original EC type or design examination certificate for parts of the design that are unchanged or those that are changed but do not affect the conformity of the subsystem, as far as it is still valid (during 10 years phase B period).

Additional EC type or design examination certificate (amending the original certificate) for modified parts of the design that affect the conformity of the subsystem with the latest revision of this TSI in force at that time.

In any case, the entity managing the change shall ensure that the technical documentation which is relating to the EC type or design examination certificate is updated accordingly.

The updated technical documentation, related to the EC type or design examination certificate is referred to in the technical file accompanying the EC declaration of verification issued by the entity managing the change for rolling stock declared as conformant to the modified type.

▼ **M3**

- 7.2.2.3. Particular rules for existing units not covered by an EC declaration of verification with a first authorisation for placing in service before 1 January 2015

The following rules apply, in addition to clause 7.1.2.2, to existing units with a first authorisation for placing in service before 1 January 2015, where the scope of the change has an impact on basic parameters not covered by the EC declaration

The compliance with technical requirements of this TSI is deemed established when a basic parameter is improved in the direction of the TSI defined performance and the entity managing the change demonstrates that the corresponding essential requirements are met and the safety level is maintained and, where reasonably practicable, improved. The entity managing the change shall in this case justify the reasons for which the TSI defined performance was not met, taking into account migration strategies of other TSIs as stated in section 7.2.2.2. This justification shall be in the technical file, if any, or in the original technical documentation of the unit.

The particular rule set out in the above paragraph is not applicable in changes impacting the basic design characteristics and classified as 21(12)a set out in table 11b. For those changes, compliance with the TSI requirements is mandatory.

Table 11b

Changes to basic parameters for which compliance with TSI requirements is mandatory for rolling stock not holding an EC type or design examination certificate

TSI clause	Related basic design characteristic(s)	Changes impacting the basic design characteristic and classified as 21(12)(a) of Directive (EU) 2016/797
4.2.3.1 Gauging	Reference profile	Change of reference profile the unit is conform to
4.2.3.3 Compatibility with train detection systems	Compatibility with train detection systems	Change of declared compatibility with one or more of the three train detection systems: Track circuits Axle counters Loop equipment
4.2.3.4 Axle bearing condition monitoring	On-board detection system	Fitting/Removal of on-board detection system
4.2.3.6.2 Characteristics of wheelsets	Wheelset gauge	Change of track gauge the wheelset is compatible with
4.2.3.6.6 Automatic variable gauge systems	Wheelset gauge changeover facility	Change of track gauge(s) the wheelset is compatible with

▼ M37.2.3. *Rules related to the EC type or design examination certificates*7.2.3.1. *Rolling stock subsystem*

This point concerns a rolling stock type (unit type in the context of this TSI), as defined in Article 2(26) of Directive (EU) 2016/797, which is subject to an EC type or design verification procedure in accordance with section 6.2 of this TSI. It also applies to the EC type or design verification procedure in accordance with the TSI Noise, which refers to this TSI for its scope of application to freight units.

The TSI assessment basis for an EC type or design examination is defined in columns 'Design review' and 'Type test' of Appendix F of this TSI and of Appendix C of the TSI Noise.

7.2.3.1.1. *Phase A*

Phase A starts once a notified body, which is responsible for EC verification, is appointed by the applicant and ends when the EC type or design examination certificate is issued.

The TSI assessment basis for a type is defined for a phase A period, with a duration of maximum four years. During the phase A period the assessment basis for EC verification to be used by the notified body will not change.

When a revision of this TSI or of the TSI Noise comes into force during the phase A period, it is permissible (but not mandatory) to use the revised version(s), either totally or for particular sections, unless explicitly otherwise specified in the revision of these TSIs. In case of application limited to particular sections, the applicant has to justify and document that applicable requirements remain consistent, and this has to be approved by the notified body.

7.2.3.1.2. *Phase B*

The phase B period defines the period of validity of the EC type or design examination certificate once it is issued by the notified body. During this time, units may be EC certified on the basis of conformity to type.

The EC type or design examination certificate of EC verification for the subsystem is valid for a ten-year phase B period after its issue date, even if a revision of this TSI or of the TSI Noise come into force, unless explicitly otherwise specified in the revision of these TSIs. During this period of validity, new rolling stock of the same type is permitted to be placed on the market on the basis of an EC declaration of verification referring to the type certificate of verification.

The updated technical documentation related to the EC type or design examination certificate is referred to in the technical file accompanying the EC declaration of verification issued by the applicant for rolling stock declared as conformant to the modified type.

7.2.3.2. *Interoperability constituents*

This point concerns interoperability constituents which are subject to EC type examination (module CB), design examination (module CH1) or to suitability for use (module CV) in accordance with section 6.1 of this TSI.

▼ M3

The EC type or design examination or suitability for use certificate is valid for a ten-year period. During this time, new constituents of the same type are permitted to be placed on the market without a new type assessment, unless explicitly otherwise specified in the revision of this TSI. Before the end of the ten-year period, the constituent shall be assessed according to the latest revision of this TSI in force at that time, for those requirements that have changed or are new in comparison to the certification basis.

▼ B7.3. **Specific cases**7.3.1. *Introduction***▼ M3**

The specific cases, as listed in point 7.3.2, are classified as:

— ‘P’ cases: ‘permanent’ cases.

— ‘T’ cases: ‘temporary’ cases, where the target system shall be reached by 31 December 2025.

All specific cases and their relevant dates shall be re-examined in the course of future revisions of the TSI with a view to limiting their technical and geographical scope based on an assessment of their impact on safety, interoperability, cross border services, TEN-T corridors, and the practical and economic impacts of retaining or eliminating them. Special account shall be given to availability of EU funding.

Specific cases shall be limited to the route or network where they are strictly necessary and taken account of through route compatibility procedures.

In case of a specific case applicable to a component defined as interoperability constituent in section 5.3 of this TSI, the conformity assessment has to be performed according to point 6.1.2.

▼ B7.3.2. *List of specific cases*7.3.2.1. **General specific cases**

Units running between a Member State and a third country with a network with 1 520 mm track gauge: Specific case Finland, Poland and Sweden.

(‘P’) The application of national technical rules instead of the requirements in this TSI is allowed for third countries rolling stock.

▼ M37.3.2.1a. **Gauging (point 4.2.3.1)**

Specific case Ireland and UK for Northern Ireland

(‘P’) It is permissible for the reference profile of the upper and the lower part of the unit to be established in accordance with the national technical rules notified for this purpose.

This specific case does not prevent access of any TSI compliant rolling stock as long as it is also compatible with an IRL gauge (track gauge system 1 600 mm).

▼ B

7.3.2.2. Axle bearing condition monitoring (point 4.2.3.4)

(a) *Specific case Sweden*

(‘T’) Units intended to operate on the Swedish railway network shall be compliant with the target and prohibitive zones as set out in Table 12.

The two zones underneath the axle box/journal set out in Table 12 referring to the parameters of the standard EN 15437-1:2009 shall be free to facilitate vertical monitoring by trackside axle box detection system:

Table 12

Target and prohibitive zone for units intended to be operated in Sweden

	Y _{TA} [mm]	W _{TA} [mm]	L _{TA} [mm]	Y _{PZ} [mm]	W _{PZ} [mm]	L _{PZ} [mm]
System 1	862	≥ 40	whole	862	≥ 60	≥ 500
System 2	905 ± 20	≥ 40	whole	905	≥ 100	≥ 500

Units mutually recognised in accordance with point 7.1.2 and units equipped with on-board axle bearing condition monitoring equipment are exempted from this specific case.

▼ M3**▼ B**

7.3.2.3. Safety against derailment running on twisted track (point 4.2.3.5.1)

Specific case UK for Great Britain

(‘P’) The limitations to the use of Method 3 set out in ► **M3** EN 14363:2016 clause 6.1.5.3.1 ◀ are not applicable for units that are intended for national use on the UK mainline network only.

▼ M3

This specific case does not prevent the access of TSI compliant rolling stock to the national network.

▼ B

7.3.2.4. Running dynamic behaviour (point 4.2.3.5.2)

▼ M3*Specific case UK for Great Britain*

(‘P’) Base condition for use of simplified measuring method specified in EN 14363:2016 clause 7.2.2 should be extended to nominal static vertical wheelset forces (PF0) up to 250 kN. For technical compatibility with the existing network it is permissible to use national technical rules amending EN 14363:2016 and notified for the purpose of running dynamic behaviour.

This specific case does not prevent the access of TSI compliant rolling stock to the national network.

▼M3*Specific case Ireland and UK for Northern Ireland*

(‘P’) For technical compatibility with the existing 1 600 mm track gauge network it is permissible to use notified national technical rules for the purpose of assessing running dynamic behaviour.

This specific case does not prevent the access of TSI compliant rolling stock to the national network.

7.3.2.5. Characteristics of wheelsets, wheels and axles (points 4.2.3.6.2 and 4.3.2.6.3)

Specific case UK for Great Britain

(‘P’) For units intended to operate solely on the railway network of Great Britain the characteristics of the wheelsets, wheels and axles may be in accordance with the national technical rules notified for this purpose.

This specific case does not prevent the access of TSI compliant rolling stock to the national network.

7.3.2.6. Attachment devices for rear end signals (point 4.2.6.3)

Specific case Ireland and UK for Northern Ireland

(‘P’) The attachment devices for rear-end signals on units intended to be operated only in traffic on networks with 1 600 mm track gauge shall conform with the national rules notified for the purpose.

This specific case does not prevent the access of TSI compliant rolling stock to the national network.

7.3.2.7. Rules to manage changes in both rolling stock and rolling stock type (7.2.2.2)

Specific case the United Kingdom (Great Britain)

(‘P’) Any change to a vehicle swept envelope as defined in the national technical rules notified for the gauging process (for example as described in RIS-2773-RST) will be categorised as 15(1)(c) of Implementing Regulation (EU) 2018/545, and will not be classified as 21(12)(a) of Directive (EU) 2016/797.

▼B

7.4. **Specific environmental conditions**

Specific conditions Finland and Sweden

For unrestricted access of rolling stock to the Finnish and Swedish network under winter conditions, it shall be demonstrated that the rolling stock meets the following requirements:

— Temperature zone T2 as specified in point 4.2.5 shall be selected.

▼B

— Snow, ice and hail severe conditions as specified in point 4.2.5 shall be selected.

Specific conditions Portugal and Spain

For unrestricted access of rolling stock to the Portuguese and Spanish network under summer conditions, temperature zone T3 as specified in point 4.2.5 shall be selected.

7.5. **Freight wagons operating under national, bilateral, multilateral or international agreements**

See Article 6.

▼M3

7.6. **Aspects that have to be considered in the revision process or in other activities of the Agency**

Further to the analysis performed during the drafting process of this TSI, particular aspects have been identified as of interest for the future development of the EU railway system.

These aspects are identified below.

7.6.1. *Rules for extension of area of use for existing rolling stock not covered by an EC declaration of verification*

Pursuant to Article 54(2) and (3) of Directive (EU) 2016/797, vehicles authorised for placing in service prior to 15 June 2016 shall receive an authorization for placing on the market according to Article 21 of Directive (EU) 2016/797 in order to operate on one or more networks which are not yet covered by their authorisation. Such vehicles shall thus be conform to this TSI or benefit from a non-application of this TSI pursuant to Article 7(1) of Directive 2016/797/EC.

In order to facilitate the free movement of vehicles, provisions shall be developed to set out which level of flexibility could be granted to such vehicles as well as to vehicles which were not subject to authorization, as regards compliance with the TSI requirements while fulfilling the essential requirements, maintaining the appropriate safety level, and where reasonably practicable, improving it.

▼ B

Appendix A

▼ M3

Not used

▼ M1

Appendix B

Not used.

▼ B*Appendix C***Additional optional conditions**

The compliance with the following set of conditions C.1 to C.18 is optional. If the applicant selects this option, a notified body has to assess the compliance within the EC verification procedure.

1. Manual coupling system

The manual coupling system shall comply with the following requirements:

- The screw coupling system excluding the draw hook shall comply with the requirements related to freight wagons of EN 15566:2009+A1:2010 except clause 4.4,
- The draw hook shall comply with the requirements related to freight wagons of EN 15566:2009+A1:2010 except clause 4.4 and except the dimension 'a' in Annex A Figure A.1 which shall be treated as informative.
- The draw hook shall be located at a height between 920 and 1 045 mm above rail level in all loading and wear conditions.
- The centreline of the draw hook shall be located within a range of 0 to 20 mm below the buffing centre.

▼ M1

- ► **M3** The clearance for the draw hook shall be in accordance with clause 6.3.2 of EN 16116-2:2013. ◀

▼ B

- The buffer shall comply with the requirements related to freight wagons of EN 15551:2009+A1:2010.
- The buffing centre line shall be located at a height between 940 and 1 065 mm above rail level in all loading and wear conditions.
- There shall be no fixed parts within 40 mm of a vertical plane placed at the end of the fully compressed buffers.

▼ M1

- ► **M3** The space for shunting staff operation shall be in accordance with clause 6.2.1 of EN 16116- 2:2013. For manual coupling systems equipped with 550 mm wide buffers the calculation of the free space may be done considering that the coupling gear components are lateral centrally positioned ($D = 0$ mm as defined in Annex A of EN 16116-2:2013). ◀

▼ B

- Where a combined automatic and screw coupler is fitted, it is permissible for the auto coupler head to infringe the space specified above for shunting staff on the left hand side when it is stowed and the screw coupler is in use. In this case the marking in Figure 75 of EN 15877-1:2012 is mandatory.

Interaction of buffers and draw gear

- The characteristics of the buffers and draw gear shall be designed in order to enable the safe transit of curves in the track with a radius of 150 m. Two units with bogies coupled on straight track with touching buffers shall generate compressive forces not higher than 250 kN on a 150 m radius curve. There is no requirement specified for two axle units.

▼ B

- The distance between the front edge of a draw-hook opening and the front side of the fully extended buffers shall be $355 \text{ mm} + 45/-20 \text{ mm}$ in the new condition as shown in Figure C.1:

Figure C.1

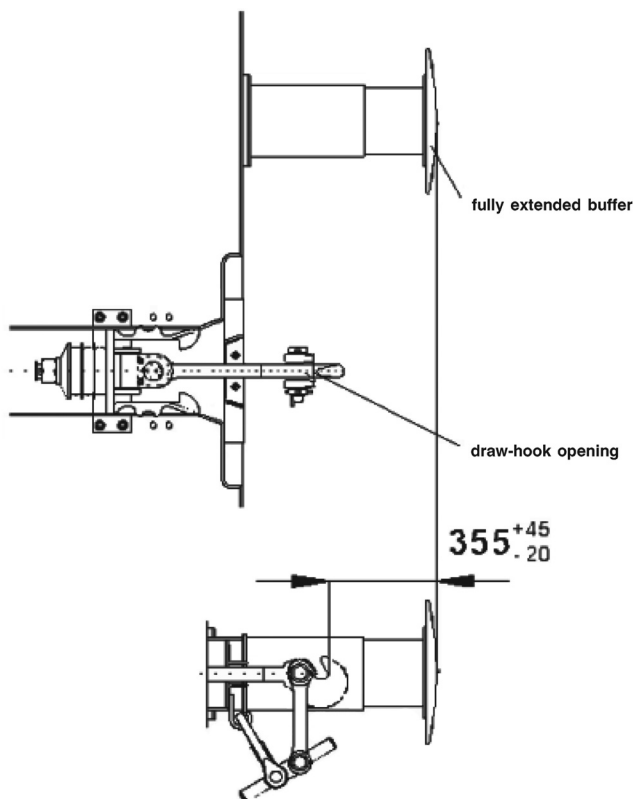
Configuration of buffers and draw gear

Units designed for 1 435 mm and 1 520 mm or 1 435 mm and 1 524 mm, or 1 435 mm and 1 668 mm gauge network(s), equipped with manual coupling and 'UIC' pneumatic brake system, shall be compatible with both,

- the interface requirements for 'End Coupling' mentioned in this Section, and
- specific buffer layouts related to broad gauge networks.

In order to provide this full compatibility, it is permitted to have a different value of the distance between buffer centrelines, 1 790 mm (Finland) and 1 850 mm (Portugal and Spain) taking into account clause 6.2.3.1 of EN 15551:2009+A1:2010.

▼ M3**2. UIC footsteps and handrails**

The unit shall be equipped with footsteps and handrails in accordance with chapters 4 and 5 of EN 16116-2:2013 and with clearances in accordance with clause 6.2.2 of EN 16116-2:2013.

▼ B**3. Ability to be hump shunted**

In addition to the requirements of point 4.2.2.2 the unit shall be assessed in accordance with clause 8 of EN 12663-2:2010 and classified in Category F I in accordance with clause 5.1 of EN 12663-2:2010 with the following exception: for units designed to carry motor vehicles or combined transport units without long stroke shock absorbers the Category F-II may be used. The requirements concerning the buffing tests in clause 8.2.5.1 of EN 12663-2:2010 apply.

▼ B**4. Free space under lifting points**

The unit shall comply with Figure C.2 on the free space under the re-railing places for rerailing:

Figure C.2

Free spaces under rerailing places

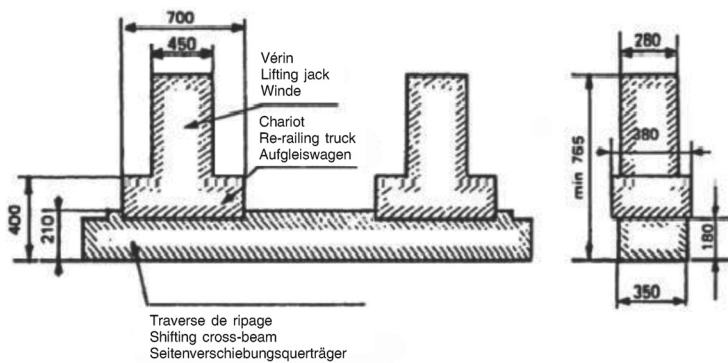
**5. Marking of units****▼ M3**

▼ B

Units compliant with all requirements set out in Section 4.2, fulfilling all conditions set out in point 7.1.2 and all conditions set out in Appendix C may receive the marking 'GE'.

Units compliant with all requirements set out in Section 4.2, fulfilling all conditions in point 7.1.2 and the conditions set out in Appendix C but not those set out in Appendix C, Sections 3 and/or 6 and/or 7.b, may receive the marking 'CW'.

If the additional marking is used, it shall be inscribed on the unit as outlined in Figure C.3.

Figure C.3

The additional markings 'GE' and 'CW'



The letters shall be of the same font type as the TEN marking. The size of the letters shall be at least 100 mm high. The outer measures of the frame shall be at least 275 mm wide and 140 mm high, the frame shall be 7 mm thick.

The marking shall be located on the right hand side of the area containing the European Vehicle Number and the TEN marking.

▼B**6. G1 gauge**

The reference contour with which the unit complies with shall be G1 and ►**M3** G11 ◀ determined as defined in point 4.2.3.1.

7. Compatibility with train detection systems

(a) The unit shall be compatible with the train detection systems based on track circuits, on axle counters and on loop equipment as specified in clauses 4.2.3.3(a), 4.2.3.3(b) and 4.2.3.3(c).

(b) The distance between two adjacent axles of the unit shall not exceed 17 500 mm.

8. Tests concerning longitudinal compressive forces

The verification of safe running under longitudinal compressive forces shall be in accordance with ►**M3** EN 15839:2012+A1:2015 ◀.

9. UIC brake

The brake system shall be compatible with vehicles equipped with UIC approved brake systems. The brake system of a unit is compatible with the UIC brake system if it fulfils the following requirements:

(a) The unit shall be equipped with a pneumatic brake pipe with an inner diameter of 32 mm.

(b) Brake modes have different brake application and release times and specific brake weight percentage.

(c) Every unit shall be fitted with a brake system having at least brake modes G and P. The brake modes G and P shall be assessed in accordance with ►**M3** UIC 540:2014 ◀.

(d) The minimum braking performance for brake-modes G and P shall be in accordance with Table C.3.

(e) If a unit is equipped with a brake system having in addition further brake modes the assessment procedure as described in point 4.2.4.3.2.1 shall be carried out for these additional brake modes. The brake application time of the P brake mode in accordance with ►**M3** UIC 540:2014 ◀ are also valid for further brake modes.

(f) The energy storage has to be designed in such way that after a brake application with the maximum brake cylinder pressure and the maximum unit specific brake cylinder stroke at any load state the pressure in the auxiliary reservoir must be at least 0,3 bar more than the brake cylinder pressure without the addition of any further energy. Details for standardised air reservoirs are set out in EN 286-3:1994 (steel) and EN 286-4:1994 (aluminium).

(g) The pneumatic energy of the brake system shall not be used for other applications different than those related to braking purposes.

(h) The distributor and distributor isolating device shall be in accordance with EN 15355:2008+A1:2010. At least one distributor shall be installed per 31 m unit length.

▼ M3

- (i) The pneumatic half coupling and its hose:

▼ B

- (i) The interface of the brake pipe shall be in accordance with EN 15807:2011.
- (ii) The opening of the automatic air brake coupling head shall face the left when looking at the end of the vehicle.
- (iii) The opening of the main reservoir coupling head shall face the right when looking at the end of the unit.
- (iv) The end cocks shall be in accordance with EN 14601:2005+A1:2010.
- (j) The brake mode switching device shall be in accordance with UIC 541-1:2010 Appendix E.

▼ M3

- (k) Brake block holders shall be in accordance with UIC 542:2015.

▼ M2

- (l) If the brake system requires a 'friction element for wheel tread brakes' interoperability constituent, the interoperability constituent shall, in addition to the requirements of point 6.1.2.5, comply with UIC leaflet 541-4:2010. The manufacturer of the friction element for wheel tread brakes, or his authorised representative established within the Union, shall in that case obtain the UIC approval.

▼ M3

- (m) Slack adjusters shall be in accordance with chapters 4 and 5 of EN 16241:2014. The assessment of conformity shall be carried out in accordance with clauses 6.3.2 to 6.3.5 of EN 16241:2014. Additionally, a life test shall be performed to demonstrate the suitability of the slack adjuster for service on the unit and to verify the maintenance requirements for the operational design life. This shall be carried out at the maximum rated load cycling through the full range of adjustment.

▼ B

- (n) If the unit is equipped with a wheel slide protection system (WSP) it shall be in accordance with EN 15595:2009+A1:2011.

▼ B

Table C.3

Minimum braking performance for brake modes G and P

▼ M1

Braking mode	Command Equipment	unit type	Load status	Requirement for running speed at 100 km/h		Requirement for running speed at 120 km/h	
				Maximum braking distance	Minimum braking distance	Maximum braking distance	Minimum braking distance
Braking mode 'P'	Changeover (°)	'S1' (²)	Empty	$S_{\max} = 700 \text{ m}$ $\lambda_{\min} = 65 \%$ $a_{\min} = 0,60 \text{ m/s}^2$	$S_{\min} = 390 \text{ m}$ $\lambda_{\max} = 125 \%, (130 \%)$ (*) $a_{\max} = 1,15 \text{ m/s}^2$	$S_{\max} = 700 \text{ m}$ $\lambda_{\min} = 100 \%$ $a_{\min} = 0,88 \text{ m/s}^2$	$S_{\min} = 580 \text{ m}$ $\lambda_{\max} = 125 \%,$ (130 %) (*) $a_{\max} = 1,08 \text{ m/s}^2$
			Inter-mediate	$S_{\max} = 810 \text{ m}$ $\lambda_{\min} = 55 \%$ $a_{\min} = 0,51 \text{ m/s}^2$	$S_{\min} = 390 \text{ m}$ $\lambda_{\max} = 125 \%$ $a_{\max} = 1,15 \text{ m/s}^2$		
			Loaded	$S_{\max} = 700 \text{ m}$ $\lambda_{\min} = 65 \%$ $a_{\min} = 0,60 \text{ m/s}^2$	$S_{\min} = \text{Max} [(S = 480 \text{ m}, \lambda_{\max} = 100 \%, a_{\max} = 0,91 \text{ m/s}^2) (S \text{ obtained with a mean retardation force of } 16,5 \text{ kN per axle})] (⁵)$		
	Variable load Relay (⁶)	'S2' (³)	Empty	$S_{\max} = 480 \text{ m}$ $\lambda_{\min} = 100 \%$ (¹) $a_{\min} = 0,91 \text{ m/s}^2$ (¹)	$S_{\min} = 390 \text{ m}$ $\lambda_{\max} = 125 \%, (130 \%)$ (*) $a_{\max} = 1,15 \text{ m/s}^2$	$S_{\max} = 700 \text{ m}$ $\lambda_{\min} = 100 \%$ $a_{\min} = 0,88 \text{ m/s}^2$	$S_{\min} = 580 \text{ m}$ $\lambda_{\max} = 125 \%,$ (130 %) (*) $a_{\max} = 1,08 \text{ m/s}^2$
			Loaded	$S_{\max} = 700 \text{ m}$ $\lambda_{\min} = 65 \%$ $a_{\min} = 0,60 \text{ m/s}^2$	$S_{\min} = \text{Max} [(S = 480 \text{ m}, \lambda_{\max} = 100 \%, a_{\max} = 0,91 \text{ m/s}^2) (S \text{ obtained with a mean retardation force of } 16,5 \text{ kN per axle})] (⁶)$		
			'SS' (⁴)	Loaded (18 t per axle for brake blocks)			$S_{\max} (⁸) = \text{Max} [S = 700 \text{ m}, \lambda_{\max} = 100 \%, a_{\max} = 0,88 \text{ m/s}^2] (S \text{ obtained with a mean retardation force of } 16 \text{ kN per axle})] (⁷)$

▼ **M1**

Braking mode	Command Equipment	unit type	Load status	Requirement for running speed at 100 km/h		Requirement for running speed at 120 km/h	
				Maximum braking distance	Minimum braking distance	Maximum braking distance	Minimum braking distance
Braking mode 'G'					There shall be no separate assessment of the braking performance of units in position G. A unit's braked weight in position G is the result of the braked weight in position P (see ► M3 UIC 544-1: 2014 ◀)		

(*) Only for two stage load brake (changeover command) and P10 (cast iron blocks with 10 % phosphor)- or LL-brake blocks
 (1) 'a' = $\frac{((\text{Speed (km/h)}/3,6)^2)/2 \times (S - ((\text{Te}) \times (\text{Speed (km/h)}/3,6)))}{\text{EN 14531-1:2015 section 4}}$, with Te = 2 sec. Distance calculation in accordance with ► **M3** EN 14531-1:2015 section 4 ◀.

(2) An 'S1' unit is a unit with empty/load device. The maximum load per axle is 22,5 t.

(3) An 'S2' unit is a unit with a variable load relay. The maximum load per axle is 22,5 t.

(4) An 'SS' unit shall be equipped with a variable load relay. The maximum load per axle is 22,5 t.

(5) The maximum mean retardation force allowed (for running speed at 100 km/h) is $18 \times 0,91 = 16,5 \text{ kN/axle}$. This value comes from the maximum braking energy input permitted on a clasp braked wheel with a nominal new diameter in the range of [920 mm; 1 000 mm] during braking (the brake weight shall be limited to 18 tonnes/axle).

(6) The maximum mean retardation force allowed (for running speed at 100 km/h) is $18 \times 0,91 = 16,5 \text{ kN/axle}$. This value comes from the maximum braking energy input permitted on a clasp braked wheel with a nominal new diameter in the range of [920 mm; 1 000 mm] during braking (the brake weight shall be limited to 18 tonnes/axle). Usually a unit, with V max = 100 km/h and fitted with a variable relay is designed to obtain $\lambda = 100 \%$ up to 14,5 t/axle.

(7) The maximum mean retardation force allowed (for running speed at 120 km/h) is $18 \times 0,88 = 16 \text{ kN/axle}$. This value comes from the maximum braking energy input permitted on a clasp braked wheel with a nominal new diameter in the range of [920 mm; 1 000 mm] during braking (the brake weight shall be limited to 18 tonnes). The mass/axle is limited to 20 t/axle and the corresponding λ is 90 %. If it is required that $\lambda > 100 \%$ with mass/axle > 18 t then it is necessary to consider another kind of brake.

(8) λ must not exceed 125 %, considering for braking only on wheels (brake blocks), the maximum mean retardation force allowed of 16 kN/axle (for running speed at 120 km/h).

(9) Changeover in accordance with EN 15624:2008 + A1:2010

(10) Variable load relay in accordance with EN 15611:2008 + A1:2010 in combination with a variable load sensing device in accordance with EN 15625:2008 + A1:2010.

▼ **B**

10. Location of parking brake handles

If a unit is equipped with a parking brake the location of its operating handle or operating wheel shall be:

— on both sides of the unit if it is operated from the ground, or

— on a platform, that can be accessed from both sides of the unit.

The operation from the ground shall be done by wheel.

▼ **M3**

11. Temperature ranges for air reservoirs, hoses and grease

The following requirements are deemed to comply with any temperature range indicated in point 4.2.5:

— Air reservoirs shall be designed for the temperature range of $-40 \text{ }^\circ\text{C}$ to $+70 \text{ }^\circ\text{C}$.

▼ M3

- Brake cylinders and brake couplings shall be designed for the temperature range of -40 °C to $+70\text{ °C}$.
- Hoses for air brakes and air supply shall be specified for the temperature range of -40 °C to $+70\text{ °C}$.

The following requirement is deemed to comply with the range T1 indicated in point 4.2.5:

- The grease for the lubrication of roller bearing shall be specified for ambient temperatures down to -20 °C .

▼ B**12. Welding****▼ M3**

Welding shall be carried out in accordance with EN 15085-1:2007+A1:2013, EN 15085-2:2007, EN 15085-3:2007, EN 15085-4:2007 and EN 15085-5:2007.

▼ B**13. Track gauge**

The unit shall be compatible with the 1 435 mm track gauge.

14. Specific brake thermal capacity

The brake system shall resist a thermal load equivalent to the suggested reference case in point 4.2.4.3.3.

▼ M2

With regard to the use of wheel tread brake systems, this condition is deemed to be met if the ‘friction element for wheel tread brakes’ interoperability constituent is, in addition to the requirements of point 6.1.2.5, compliant with UIC leaflet 541-4:2010, and if the wheel:

- is assessed in accordance with point 6.1.2.3; and
- fulfils the conditions of Section 15 of Appendix C.

▼ B**15. Specific product properties concerning the wheel**

The wheels shall be in accordance with EN 13262:2004+A1:2008+A2:2011 and EN 13979-1:2003+A1:2009+A2:2011. The thermal mechanical type test required in point 6.1.2.3 shall be carried out in accordance with Table C.4 when the complete brake system is acting directly on the wheel tread.

Table C.4

Conditions for the thermal mechanical type test

Wheel diameter range [mm]	1 000-920	920-840	840-760	760-680
Standard power value	50 kW	50 kW	42,5 kW	38 kW
Application time	45 min	45 min	45 min	45 min
Running speed	60 km/h	60 km/h	60 km/h	60 km/h

16. Tow hooks

Units shall be provided with tow hooks, each one being fixed to the side of the unit underframe in accordance with clause 1.4 of UIC 535-2:2006.

▼ M3

Alternative technical solutions are allowed as far as conditions 1.4.2 to 1.4.9 of UIC 535-2:2006 are respected. If the alternative solution is a cable eye bracket, it shall in addition have a minimum diameter of 85 mm.

▼ B**17. Protective devices on protruding parts**

To ensure the safety of staff, protruding (e.g. angular or pointed) parts of the unit located up to 2 m above rail level or above passageways, working surfaces or tow hooks which are liable to cause accidents, shall be fitted with protective devices as described in clause 1.3 of UIC 535-2:2006.

18. Label holders and attachment devices for rear-end signal

All units shall be equipped with a label holder in accordance with clause 1 of UIC 575:1995 and at both ends with attachment devices as set out in point 4.2.6.3.

▼ M3**19. Axle bearing condition monitoring**

It shall be possible to monitor the axle bearing condition of the unit by means of line side detection equipment.

▼ **M3***Appendix D***Mandatory standards or normative documents referred to in this TSI**

TSI		Standard/document	
Characteristics to be assessed		References to Standard or document	Clauses
Structure and mechanical part	4.2.2		
Strength of unit	4.2.2.2	EN 12663-2:2010	5
		EN 15877-1:2012	4.5.14
	6.2.2.1	EN 12663-1:2010+A1:2014	9.2
		EN 12663-2:2010	6, 7
Gauging and track interaction	4.2.3		
Gauging	4.2.3.1	EN 15273-2:2013	all
Compatibility with load carrying capacity of lines	4.2.3.2	EN 15528:2015	6.1, 6.2
Compatibility with train detection systems	4.2.3.3	ERA/ERTMS/033281 rev. 4.0	See table 7 of this TSI
Axle bearing condition monitoring	4.2.3.4	EN 15437-1:2009	5.1, 5.2
Safety against derailment running on twisted track	4.2.3.5.1	—	—
	6.2.2.2	EN 14363:2016	4, 5, 6.1
Running dynamic behaviour	4.2.3.5.2	EN 14363:2016	4, 5, 7
	6.1.2.1	EN 14363:2016	4, 5, 7
	6.2.2.3	EN 16235:2013	all
	6.1.2.1	EN 13749:2011	6.2
Structural design of bogie frame	4.2.3.6.1	EN 13749:2011	6.2
	6.1.2.1	EN 13749:2011	6.2
Characteristics of wheelsets	4.2.3.6.2	—	—
	6.1.2.2	EN 13260:2009+A1:2010	3.2.1
Characteristics of wheels	4.2.3.6.3	—	—
	6.1.2.3	EN 13979-1:2003+A1:2009 +A2:2011	7, 6.2
Characteristics of axles	4.2.3.6.4	—	—
	6.1.2.4	EN 13103:2009 + A2:2012	4, 5, 6, 7
Axle boxes/bearings	4.2.3.6.5	—	—

▼ **M3**

TSI		Standard/document	
Characteristics to be assessed		References to Standard or document	Clauses
	6.2.2.4	EN 12082:2007+A1:2010	6
Running gear for manual change of wheelsets	4.2.3.6.7	—	—
	6.2.2.5	UIC leaflet 430-1:2012	Annexes B, H, I
UIC 430-3:1995		Annex 7	
Brake	4.2.4		
Service brake	4.2.4.3.2.1	EN 14531-6:2009	all
		UIC 544-1:2014	all
Parking brake	4.2.4.3.2.2	EN 14531-6:2009	6
Friction element for wheel tread brakes	4.2.4.3.5	—	—
	6.1.2.5	ERA technical document ERA/TD/2013-02/INT Version 3.0 of 27.11.2015	All
Environmental conditions	4.2.5		
Environmental conditions	4.2.5	EN 50125-1:2014	4.7
	6.2.2.7	—	—
System protection	4.2.6		
Barriers	4.2.6.1.2.1	—	—
	6.2.2.8.1	EN 1363-1:2012	all
Materials	4.2.6.1.2.2	—	—
	6.2.2.8.2	ISO 5658- 2:2006/Am1:2011	all
		EN 13501-1:2007+A1:2009	all
		EN 45545-2:2013+A1:2015	Table 6
ISO 5660-1:2015		all	
Cables	6.2.2.8.3	EN 50355:2013	all
		EN 50343:2014	all
Flammable liquids	6.2.2.8.4	EN 45545-7:2013	all
Protective measures against indirect contact (protective bonding)	4.2.6.2. 1	EN 50153:2014	6.4
Protective measures against direct contact	4.2.6.2. 2	EN 50153:2014	5
Attachment devices for rear-end signal	4.2.6.3	EN 16116-2:2013	Figure 11

▼ **M3**

Standards or documents referred to in the additional optional conditions set out in Appendix C:

Additional optional conditions for units	App. C	Standard/UIC leaflet/document	
Manual coupling system	C.1	EN 15566:2009+A1:2010	all (except 4.4)
		EN 15551:2009+A1:2010	all
		EN 16116-2:2013	6.2.1, 6.3.2
		EN 15877-1:2012	Figure 75
UIC footsteps and handrails	C.2	EN 16116-2:2013	4, 5, 6.2.2
Ability to be hump shunted	C.3	EN 12663-2:2010	5, 8
Tests concerning longitudinal compressive forces	C.8	EN 15839:2012+A1:2015	all
UIC brake	C.9	EN 15355:2008+A1:2010	all
		EN 15611:2008+A1:2010	all
		UIC 540:2014	all
		EN 14531-1:2015	4
		EN 15624:2008+A1:2010	all
		EN 15625:2008+A1:2010	all
		EN 286-3:1994	all
		EN 286-4:1994	all
		EN 15807:2011	all
		EN 14601:2005+A1:2010	all
		UIC 544-1:2014	all
		UIC 542:2015	all
		EN 16241:2014	4, 5, 6.3.2 to 6.3.5
		EN 15595:2009+A1:2011	all
Welding	C.12	EN 15085-1:2007+A1:2013 EN 15085-2:2007	all
		EN 15085-3:2007	
		EN 15085-4:2007	
		EN 15085-5:2007	
Specific product properties concerning the wheel	C.15	EN 13262:2004 +A1:2008+A2:2011	all
		EN 13979-1:2003 +A1:2009+A2:2011	all

▼ M3

Additional optional conditions for units	App. C	Standard/UIC leaflet/document	
Tow hooks	C.16	UIC 535-2:2006	1.4
Protective devices on protruding parts	C.17	UIC 535-2:2006	1.3
Label holders and attachment devices for rear end signal	C.18	UIC 575:1995	1

▼ B*Appendix E***Rear-end signal****1. Lamps****▼ M2**

The colour of tail lamps shall be in accordance with clause 5.5.3 of ►**M3** EN 15153-1:2013+A1:2016 ◀.

▼ M3

The tail lamp shall be designed to display a lighting intensity in accordance with table 8 of EN 15153-1:2013+A1:2016.

▼ B

The lamp shall be suitable to be attached to units complying with the attachment devices and the clearance set out in point 4.2.6.3. The lamp shall be equipped with:

- a switch (on/off),
- a warning light which indicates the battery status.

2. Reflective plates

The reflective plates shall be suitable to be attached to units complying with the attachment devices and the clearance set out in point 4.2.6.3. The reflective section of the plates shall be at least 150 by at least 200 mm as illustrated in Figure E.1. The side triangles shall be white, the top and the bottom triangles shall be red. The plate shall be retro-reflective in accordance with EN 12899-1:2007 Class Ref. 2.

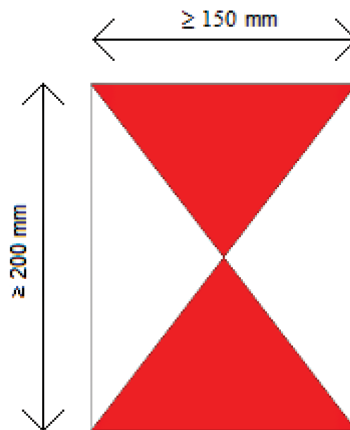
*Figure E.1***Reflective plate**

▼B

Appendix F

Assessment assigned to the production phases

Table F.1

Assessment assigned to the production phases

Characteristics to be assessed, as specified in Section 4.2		Design and development phase		Production phase	Particular assessment procedure
		Design review	Type test	Routine test	
Element of the Rolling Stock sub-system	Point				Point
Structure and mechanical part	4.2.2				
End coupling	4.2.2.1.1	X	n.a.	n.a.	—
Inner coupling	4.2.2.1.2	X	n.a.	n.a.	—
Strength of unit	4.2.2.2	X	X	n.a.	6.2.2.1
Integrity of the unit	4.2.2.3	X	n.a.	n.a.	—
Vehicle track interaction and gauging	4.2.3				
Gauging	4.2.3.1	X	n.a.	n.a.	—
Compatibility with load carrying capacity of lines	4.2.3.2	X	X	n.a.	—
Compatibility with train detection systems	4.2.3.3	X	X	n.a.	—
Axle bearing condition monitoring	4.2.3.4	X	X	n.a.	—
Safety against derailment running on twisted track	4.2.3.5.1	X	X	n.a.	6.2.2.2
Running dynamic behaviour	4.2.3.5.2	X	X	n.a.	6.1.2.1/6.2.2.3
Structural design of bogie frame	4.2.3.6.1	X	X	n.a.	6.1.2.1
Characteristics of wheelsets	4.2.3.6.2	X	X	X	6.1.2.2
Characteristics of wheels	4.2.3.6.3	X	X	X	6.1.2.3
Characteristics of axles	4.2.3.6.4	X	X	X	6.1.2.4
Axle boxes/bearings	4.2.3.6.5	X	X	X	6.2.2.4
Automatic variable gauge system	4.2.3.6.6	X	X	X	6.1.2.6/6.2.2.4a
Running gear for manual change of wheelsets	4.2.3.6.7	X	X	n.a.	6.2.2.5

▼M3▼B

▼ **B**

Characteristics to be assessed, as specified in Section 4.2		Design and development phase		Production phase	Particular assessment procedure
		Design review	Type test	Routine test	
Brake	4.2.4				
Safety requirements	4.2.4.2	X	n.a	n.a	—
Functional and technical requirements	4.2.4.3	X	X	n.a	—
In-service brake	4.2.4.3.2.1	X	X	n.a.	—
Parking brake	4.2.4.3.2.2	X	n.a	n.a	—
Thermal capacity	4.2.4.3.3	X	X	n.a	6.2.2.6
Wheel slide protection (WSP)	4.2.4.3.4	X	X	n.a	—
Friction elements for wheel tread brakes	4.2.4.3.5	X	X	X	6.1.2.5
Environmental conditions	4.2.5				
Environmental conditions	4.2.5	X	n.a. /X (1)	n.a.	6.2.2.7
System protection	4.2.6				
Fire safety	4.2.6.1	X	X	n.a	6.2.2.8
Protection against electric hazard	4.2.6.2	X	X	n.a	—
Attachment devices for rear-end signal	4.2.6.3	X	X	n.a	—

▼ **M2**▼ **B**

(1) Type test if and as defined by the applicant.

▼B

Appendix G

List of fully approved composite brake blocks for international transport

This Appendix is published on the ERA website (<http://www.era.europa.eu>).