

---

**Changes to legislation:** *There are outstanding changes not yet made to Commission Regulation (EU) No 1301/2014. Any changes that have already been made to the legislation appear in the content and are referenced with annotations. (See end of Document for details) [View outstanding changes](#)*

---

Commission Regulation (EU) No 1301/2014 of 18 November 2014 on the technical specifications for interoperability relating to the ‘energy’ subsystem of the rail system in the Union (Text with EEA relevance)

---

**Changes to legislation:** There are outstanding changes not yet made to Commission Regulation (EU) No 1301/2014. Any changes that have already been made to the legislation appear in the content and are referenced with annotations. (See end of Document for details) View outstanding changes

---

## ANNEX

### 1. INTRODUCTION

#### [<sup>F1</sup>1.1. **Technical Scope**

This TSI concerns the energy subsystem and part of the maintenance subsystem of the Union rail system in accordance with Article 1 of Directive (EU) 2016/797.

The energy and the maintenance subsystems are defined respectively in points 2.2 and 2.8 of Annex II to Directive (EU) 2016/797.

The technical scope of this TSI is further defined in Article 2 of this Regulation.]

#### **Textual Amendments**

**F1** Substituted by [Commission Implementing Regulation \(EU\) 2019/776 of 16 May 2019 amending Commission Regulations \(EU\) No 321/2013, \(EU\) No 1299/2014, \(EU\) No 1301/2014, \(EU\) No 1302/2014, \(EU\) No 1303/2014 and \(EU\) 2016/919 and Commission Implementing Decision 2011/665/EU as regards the alignment with Directive \(EU\) 2016/797 of the European Parliament and of the Council and the implementation of specific objectives set out in Commission Delegated Decision \(EU\) 2017/1474 \(Text with EEA relevance\).](#)

#### 1.2. **Geographical scope**

The geographical scope of this TSI is defined in Article 2(4) of this Regulation.

#### 1.3. **Content of this TSI**

- (1) [<sup>F1</sup>In accordance with Article 4(3) of Directive (EU) 2016/797, this TSI:
- (a) indicates its intended scope (section 2);
  - (b) lays down essential requirements for the energy and part of the maintenance subsystems (section 3);
  - (c) establishes the functional and technical specifications to be met by the energy and part of the maintenance subsystems and its interfaces vis-à-vis other subsystems (section 4);
  - (d) specifies the interoperability constituents and interfaces which must be covered by European specifications, including European standards, which are necessary to achieve interoperability within the Union rail system (section 5);
  - (e) states, in each case under consideration, which procedures are to be used in order to assess the conformity or the suitability for use of the interoperability constituents, on the one hand, or the EC verification of the subsystems, on the other hand (section 6);
  - (f) indicates the strategy for implementing this TSI (section 7);
  - (g) indicates, for the staff concerned, the professional qualifications and health and safety conditions at work required for the operation and maintenance of the energy subsystem, as well as for the implementation of this TSI (section 4);

---

**Changes to legislation:** There are outstanding changes not yet made to Commission Regulation (EU) No 1301/2014. Any changes that have already been made to the legislation appear in the content and are referenced with annotations. (See end of Document for details) View outstanding changes

---

- (h) indicates the provisions applicable to the existing energy subsystem, in particular in the event of upgrading and renewal and, in such cases, the modification work which requires an application for a new authorisation;
  - (i) indicates the parameters of energy subsystem to be checked by the railway undertaking and the procedures to be applied to check those parameters after the delivery of the vehicle authorisation for placing on the market and before the first use of the vehicle to ensure compatibility between vehicles and the routes on which they are to be operated.
- (2) In accordance with Article 4(5) of the Directive (EU) 2016/797, provisions for specific cases are indicated in Section 7.]
- (3) Requirements in this TSI are valid for all track gauge systems within the scope of this TSI, unless a paragraph refers to specific track gauge systems or to specific nominal track gauges.

## 2. DESCRIPTION OF THE ENERGY SUBSYSTEM

### 2.1. Definition

- (1) This TSI covers all fixed installations necessary to achieve interoperability that are required to supply traction energy to a train.
- (2) The energy subsystem consists of:
- (a) substations : connected on the primary side to the high-voltage grid, with transformation of the high-voltage to a voltage and/or conversion to a power supply system suitable for the trains. On the secondary side, substations are connected to the railway contact line system;
  - (b) sectioning locations : electrical equipment located at intermediate locations between substations to supply and parallel contact lines and to provide protection, isolation and auxiliary supplies;
  - (c) separation sections : equipment required to provide the transition between electrically different systems or between different phases of the same electrical system;
  - (d) contact line system : a system that distributes the electrical energy to the trains running on the route and transmits it to the trains by means of current collectors. The contact line system is also equipped with manually or remotely controlled disconnectors which are required to isolate sections or groups of the contact line system according to operational necessity. Feeder lines are also part of the contact line system;
  - (e) return circuit : all conductors which form the intended path for the traction return current. Therefore, so far as this aspect is concerned, the return circuit is part of the energy subsystem and has an interface with the infrastructure subsystem.
- (3) [<sup>F2</sup>In accordance with Annex II, Section 2.2 of [<sup>F1</sup>Directive (EU) 2016/797], the trackside of the electricity consumption measuring system, referred to in this TSI as on-ground energy data collecting system, is set out in point 4.2.17 of this TSI.]

**Changes to legislation:** There are outstanding changes not yet made to Commission Regulation (EU) No 1301/2014. Any changes that have already been made to the legislation appear in the content and are referenced with annotations. (See end of Document for details) View outstanding changes

### Textual Amendments

- F2** Substituted by [Commission Implementing Regulation \(EU\) 2018/868 of 13 June 2018 amending Regulation \(EU\) No 1301/2014 and Regulation \(EU\) No 1302/2014 as regards provisions on energy measuring system and data collecting system \(Text with EEA relevance\).](#)

#### 2.1.1. *Power supply*

- (1) The objective of the power supply system is to supply every train with power in order to meet the planned timetable.
- (2) Basic parameters for power supply system are defined in point 4.2.

#### 2.1.2. *Geometry of the overhead contact line (OCL) and quality of current collection*

- (1) The objective is to ensure reliable and continuous power transfer from the power supply system to the rolling stock. The interaction between the overhead contact line and the pantograph is an important aspect of interoperability.
- (2) Basic parameters referring to the geometry of the OCL and quality of current collection are set out in point 4.2.

### 2.2. **Interfaces with other subsystems**

#### 2.2.1. *Introduction*

- (1) The energy subsystem interfaces with other subsystems of the rail system in order to achieve the envisaged performance. These subsystems are listed below:
  - (a) Rolling stock;
  - (b) Infrastructure;
  - (c) Trackside control command and signalling;
  - (d) On-board control command and signalling;
  - (e) Operation and traffic management.
- (2) Point 4.3 of this TSI sets out the functional and technical specification of these interfaces.

#### 2.2.2. *Interfaces of this TSI with the Safety in railway tunnels TSI*

Requirements relating to the energy subsystem for safety in railway tunnels are set out in the TSI relating to Safety in railway tunnels.

### 3. ESSENTIAL REQUIREMENTS

The following table indicates basic parameters of this TSI and their correspondence to the essential requirements as set out and numbered in Annex III of <sup>F1</sup>Directive (EU) 2016/797].

TSI point	Title of TSI point	Safety	R&A	Health	Environmental protection	Tech. Compatibility	Accessibility
-----------	--------------------	--------	-----	--------	--------------------------	---------------------	---------------

**Changes to legislation:** There are outstanding changes not yet made to Commission Regulation (EU) No 1301/2014. Any changes that have already been made to the legislation appear in the content and are referenced with annotations. (See end of Document for details) View outstanding changes

4.2.3	Voltage and frequency	—	—	—	—	1.5 2.2.3	—
4.2.4	Parameters relating to supply system performance	—	—	—	—	1.5 2.2.3	—
4.2.5	Current capacity, DC systems, trains at standstill	—	—	—	—	1.5 2.2.3	—
4.2.6	Regenerative braking	—	—	—	1.4.1 1.4.3	1.5 2.2.3	—
4.2.7	Electrical protection coordination arrangements	2.2.1	—	—	—	1.5	—
4.2.8	Harmonics and dynamic effects for AC traction power supply systems	—	—	—	1.4.1 1.4.3	1.5	—
4.2.9	Geometry of the overhead contact line	—	—	—	—	1.5 2.2.3	—
4.2.10	Pantograph gauge	—	—	—	—	1.5 2.2.3	—
4.2.11	Mean contact force	—	—	—	—	1.5 2.2.3	—
4.2.12	Dynamic behaviour and quality of current collection	—	—	—	1.4.1 2.2.2	1.5 2.2.3	—
4.2.13	Pantograph spacing	—	—	—	—	1.5 2.2.3	—

**Changes to legislation:** There are outstanding changes not yet made to Commission Regulation (EU) No 1301/2014. Any changes that have already been made to the legislation appear in the content and are referenced with annotations. (See end of Document for details) View outstanding changes

	for overhead contact line design						
4.2.14	Contact wire material	—	—	1.3.1 1.3.2	1.4.1	1.5 2.2.3	—
4.2.15	Phase separation sections	2.2.1	—	—	1.4.1 1.4.3	1.5 2.2.3	—
4.2.16	System separation sections	2.2.1	—	—	1.4.1 1.4.3	1.5 2.2.3	—
4.2.17	On-ground energy data collecting system	—	—	—	—	1.5	—
4.2.18	Protective provisions against electric shock	1.1.1 1.1.3 2.2.1	—	—	1.4.1 1.4.3 2.2.2	1.5	—
4.4	Operating rules	2.2.1	—	—	—	1.5	—
4.5	Maintenance rules	1.1.1 2.2.1	1.2	—	—	1.5 2.2.3	—
4.6	Professional qualifications	2.2.1	—	—	—	—	—
4.7	Health and safety conditions	1.1.1 1.1.3 2.2.1	—	—	1.4.1 1.4.3 2.2.2	—	—

#### 4. CHARACTERISATION OF THE SUBSYSTEM

##### 4.1. Introduction

- (1) The whole rail system, to which [F1Directive (EU) 2016/797] applies and of which the energy subsystem is a part, is an integrated system whose consistency needs to be verified. This consistency must be checked, in particular, with regard to the specifications of the energy subsystem, its interfaces vis-à-vis the system in which it is integrated, as well as the operating and maintenance rules. The functional and technical specifications of the subsystem and its interfaces, described in points 4.2 and 4.3, do not impose the use of specific technologies or technical solutions, except where this is strictly necessary for the interoperability of the rail network.

---

**Changes to legislation:** There are outstanding changes not yet made to Commission Regulation (EU) No 1301/2014. Any changes that have already been made to the legislation appear in the content and are referenced with annotations. (See end of Document for details) View outstanding changes

---

- (2) Innovative solutions for interoperability, which do not fulfil requirements specified in this TSI and are not assessable as stated in this TSI, require new specifications and/or new assessment methods. In order to allow technological innovation, these specifications and assessment methods shall be developed by the process for innovative solutions described in points 6.1.3 and 6.2.3.
- (3) Taking account of all the applicable essential requirements, the energy subsystem is characterised by the specifications set out in points 4.2 to 4.7.
- (4) Procedures for the EC verification of the energy subsystem are indicated in point 6.2.4 and Appendix B, Table B.1, of this TSI.
- (5) For specific cases, see point 7.4.
- (6) Where reference is made to EN standards in this TSI, any variations called ‘national deviations’ or ‘special national conditions’ in the EN standards are not applicable and do not form part of this TSI.

#### 4.2. **Functional and technical specifications of the subsystem**

##### 4.2.1. *General provisions*

The performance to be achieved by the energy subsystem is specified at least by the required performance of the rail system with respect to:

- (a) maximum line speed;
- (b) type(s) of train;
- (c) train service requirements;
- (d) power demand of the trains at the pantographs.

##### 4.2.2. *Basic parameters characterising the energy subsystem*

The basic parameters characterising the energy subsystem are:

###### 4.2.2.1. Power supply:

- (a) Voltage and frequency (4.2.3);
- (b) Parameters relating to supply system performance (4.2.4);
- (c) Current capacity, DC systems, trains at standstill (4.2.5);
- (d) Regenerative braking (4.2.6);
- (e) Electrical protection coordination arrangements (4.2.7);
- (f) Harmonics and dynamic effects for AC traction power supply systems (4.2.8).

###### 4.2.2.2. Geometry of the OCL and quality of current collection:

- (a) Geometry of the overhead contact line (4.2.9);
- (b) Pantograph gauge (4.2.10);
- (c) Mean contact force (4.2.11);
- (d) Dynamic behaviour and quality of current collection (4.2.12);

---

**Changes to legislation:** There are outstanding changes not yet made to Commission Regulation (EU) No 1301/2014. Any changes that have already been made to the legislation appear in the content and are referenced with annotations. (See end of Document for details) View outstanding changes

---

- (e) Pantograph spacing for overhead contact line design (4.2.13);
- (f) Contact wire material (4.2.14);
- (g) Phase separation sections (4.2.15);
- (h) System separation sections (4.2.16).

4.2.2.3. On-ground energy data collecting system (4.2.17)

4.2.2.4. Protective provisions against electric shock (4.2.18)

4.2.3. *Voltage and frequency*

(1) The voltage and frequency of the energy subsystem shall be one of the four systems, specified in accordance with Section 7:

- (a) AC 25 kV, 50 Hz;
- (b) AC 15 kV, 16,7 Hz;
- (c) DC 3 kV;
- (d) DC 1,5 kV.

(2) The values and limits of the voltage and frequency shall comply with EN 50163:2004, clause 4 for the selected system.

4.2.4. *Parameters relating to supply system performance*

The following parameters shall be taken in consideration:

- (a) maximum train current (4.2.4.1);
- (b) power factor of trains and the mean useful voltage (4.2.4.2).

4.2.4.1. *Maximum train current*

The energy subsystem design shall ensure the ability of the power supply to achieve the specified performance and allow the operation of trains with a power less than 2 MW without power or current limitation.

4.2.4.2. *Mean useful voltage*

The calculated mean useful voltage 'at the pantograph' shall comply with EN 50388:2012, clause 8 (except clause 8.3 that is replaced by point C.1 of Appendix C). Simulation shall take into account values of the real power factor of trains. Point C.2 of Appendix C provides additional information to clause 8.2 of the EN 50388:2012.

[<sup>F2</sup>4.2.5. *Current at standstill (DC systems only)*]

- (1) The OCL of DC systems shall be designed to sustain 300 A (for a 1,5 kV supply system) and 200 A (for a 3 kV supply system), per pantograph when the train is at standstill.
- (2) The current capacity at standstill shall be achieved for the test value of static contact force given in table 4 of clause 7.2 of EN 50367:2012.
- (3) The OCL shall be designed taking into account the temperature limits in accordance with EN 50119:2009, clause 5.1.2.



---

**Changes to legislation:** There are outstanding changes not yet made to Commission Regulation (EU) No 1301/2014. Any changes that have already been made to the legislation appear in the content and are referenced with annotations. (See end of Document for details) View outstanding changes

---

#### 4.2.6. Regenerative braking

- (1) AC power supply systems shall be designed to allow the use of regenerative braking able to exchange power seamlessly either with other trains or by any other means.
- (2) DC power supply systems shall be designed to permit the use of regenerative braking at least by exchanging power with other trains.

#### 4.2.7. Electrical protection coordination arrangements

Electrical protection coordination design of the energy subsystem shall comply with the requirements detailed in EN 50388:2012, clause 11.

#### 4.2.8. Harmonics and dynamic effects for AC traction power supply systems

- (1) The interaction of traction power supply system and rolling stock can lead to electrical instabilities in the system.
- (2) In order to achieve electrical system compatibility, harmonic overvoltages shall be limited below critical values according to EN 50388:2012, clause 10.4.

#### 4.2.9. Geometry of the overhead contact line

- (1) The overhead contact line shall be designed for pantographs with the head geometry specified in the LOC & PAS TSI, point 4.2.8.2.9.2 taking into account the rules set out in point 7.2.3 of this TSI.
- (2) The contact wire height and the lateral deviation of the contact wire under the action of a cross-wind are factors which govern the interoperability of the rail network.

##### 4.2.9.1. Contact wire height

- (1) The permissible data for contact wire height is given in Table 4.2.9.1.

---

Table 4.2.9.1

#### Contact wire height

Description	v ≥ 250 [km/h]	v < 250 [km/h]
Nominal contact wire height [mm]	Between 5 080 and 5 300	Between 5 000 and 5 750
Minimum design contact wire height [mm]	5 080	In accordance with EN 50119:2009, clause 5.10.5 depending on the chosen gauge
Maximum design contact wire height [mm]	5 300	6 200 <sup>a</sup>

<sup>a</sup> Taking into account tolerances and uplift in accordance with EN 50119:2009 figure 1, the maximum contact wire height shall not be greater than 6 500 mm.

- (2) For the relation between the contact wire heights and pantograph working heights see EN 50119:2009 figure 1.
- (3) At level crossings the contact wire height shall be specified by national rules or in the absence of national rules, according to EN 50122-1:2011, clauses 5.2.4 and 5.2.5.

---

**Changes to legislation:** There are outstanding changes not yet made to Commission Regulation (EU) No 1301/2014. Any changes that have already been made to the legislation appear in the content and are referenced with annotations. (See end of Document for details) View outstanding changes

---

- (4) For the track gauge system 1 520 and 1 524 mm the values for contact wire height are as follows:
- (a) Nominal contact wire height: between 6 000 mm and 6 300 mm;
  - (b) Minimum design contact wire height: 5 550 mm;
  - (c) Maximum design contact wire height: 6 800 mm.

#### 4.2.9.2. Maximum lateral deviation

- (1) The maximum lateral deviation of the contact wire in relation to the track centre line under action of a cross wind shall be in accordance to table 4.2.9.2.

Table 4.2.9.2

<b>Maximum lateral deviation depending on the pantograph length</b>	
<b>Pantograph length [mm]</b>	<b>Maximum lateral deviation [mm]</b>
1 600	400 <sup>a</sup>
1 950	550 <sup>a</sup>

**a** The values shall be adjusted taking into account the movement of the pantograph and track tolerances according to Appendix D.1.4.

- (2) In the case of the multi-rail track, the requirement for lateral deviation shall be fulfilled for each pair of rails (designed, to be operated as a separated track) that is intended to be assessed against TSI.
- (3) Track gauge system 1 520 mm:  
For Member States applying the pantograph profile according to LOC&PAS TSI, point 4.2.8.2.9.2.3 the maximum lateral deviation of the contact wire in relation to the pantograph centre under action of a cross wind shall be 500 mm.

#### 4.2.10. Pantograph gauge

- (1) No part of the energy sub-system shall enter the mechanical kinematic pantograph gauge (see Appendix D figure D.2) except for the contact wire and steady arm.
- (2) The mechanical kinematic pantograph gauge for interoperable lines is specified using the method shown in Appendix D.1.2 and the pantograph profiles defined in LOC&PAS TSI, points 4.2.8.2.9.2.1 and 4.2.8.2.9.2.2.
- (3) This gauge shall be calculated using a kinematic method, with values:
- (a) for the pantograph sway  $e_{pu}$  of 0,110 m at the lower verification height  $h'_u = 5,0$  m and
  - (b) for the pantograph sway  $e_{po}$  of 0,170 m at the upper verification height  $h'_o = 6,5$  m,

in accordance with point D.1.2.1.4 of Appendix D and other values in accordance with point D.1.3 of Appendix D.

- (4) Track gauge system 1 520 mm:

**Changes to legislation:** There are outstanding changes not yet made to Commission Regulation (EU) No 1301/2014. Any changes that have already been made to the legislation appear in the content and are referenced with annotations. (See end of Document for details) View outstanding changes

For Member States applying the pantograph profile according to LOC&PAS TSI, point 4.2.8.2.9.2.3 the static gauge available for pantograph is defined in point D.2 of Appendix D.

#### 4.2.11. Mean contact force

- (1) The mean contact force  $F_m$  is the statistical mean value of the contact force.  $F_m$  is formed by the static, dynamic and aerodynamic components of the pantograph contact force.
- (2) The ranges of  $F_m$  for each of the power supply systems are defined in EN 50367:2012 Table 6.
- (3) The overhead contact lines shall be designed to be capable to sustain the upper design limit of  $F_m$  given in EN 50367:2012 Table 6.
- (4) [<sup>F1</sup>The curves apply to speed up to 360 km/h. For speeds above 360 km/h procedures set out in point 6.1.3 shall apply.]

#### 4.2.12. Dynamic behaviour and quality of current collection

- (1) Depending on the assessment method, the overhead contact line shall achieve the values of dynamic performance and contact wire uplift (at the design speed) set out in Table 4.2.12.

Table 4.2.12

#### Requirements for dynamic behaviour and current collection quality

Requirement	$v \geq 250$ [km/h]	$250 > v > 160$ [km/h]	$v \leq 160$ [km/h]
Space for steady arm uplift	$2S_0$		
Mean contact force $F_m$	See 4.2.11		
Standard deviation at maximum line speed $\sigma_{max}$ [N]	$0,3F_m$		
Percentage of arcing at maximum line speed, NQ [%] (minimum duration of arc 5 ms)	$\leq 0,2$	$\leq 0,1$ for AC systems $\leq 0,2$ for DC systems	$\leq 0,1$

- (2)  $S_0$  is the calculated, simulated or measured uplift of the contact wire at a steady arm, generated in normal operating conditions with one or more pantographs with the upper limit of  $F_m$  at the maximum line speed. When the uplift of the steady arm is physically limited due to the overhead contact line design, it is permissible for the necessary space to be reduced to  $1,5S_0$  (refer to EN 50119:2009, clause 5.10.2).
- (3) Maximum force ( $F_{max}$ ) is usually within the range of  $F_m$  plus three standard deviations  $\sigma_{max}$ ; higher values may occur at particular locations and are given in EN 50119:2009,

**Changes to legislation:** There are outstanding changes not yet made to Commission Regulation (EU) No 1301/2014. Any changes that have already been made to the legislation appear in the content and are referenced with annotations. (See end of Document for details) View outstanding changes

table 4, clause 5.2.5.2. For rigid components such as section insulators in overhead contact line systems, the contact force can increase up to a maximum of 350 N.

#### 4.2.13. Pantograph spacing for overhead contact line design

[<sup>F2</sup>The overhead contact line shall be designed for a minimum of two pantographs operating adjacently. The design spacing of the two adjacent pantograph heads, centre line to centre line, shall be equal or lower than values set out in one column 'A', 'B', or 'C' selected from Table 4.2.13:]

TABLE 4.2.13

#### Pantograph spacing for OCL design

Design speed [km/h]	AC [ <sup>F3</sup> Minimum] distance [m]			3 kV DC [ <sup>F3</sup> Minimum] distance [m]			1,5 kV DC [ <sup>F3</sup> Minimum] distance [m]		
	A	B	C	A	B	C	A	B	C
v ≥ 250	200			200			200	200	35
160 < v < 250	200	85	35	200	115	35	200	85	35
120 < v ≤ 160	85	85	35	20	20	20	85	35	20
80 < v ≤ 120	20	15	15	20	15	15	35	20	15
v ≤ 80	8	8	8	8	8	8	20	8	8

#### Textual Amendments

**F3** Deleted by Commission Implementing Regulation (EU) 2018/868 of 13 June 2018 amending Regulation (EU) No 1301/2014 and Regulation (EU) No 1302/2014 as regards provisions on energy measuring system and data collecting system (Text with EEA relevance).

#### 4.2.14. Contact wire material

- (1) The combination of contact wire material and contact strip material has a strong impact on the wear of contact strips and contact wire.
- (2) Permissible contact strip materials are defined in point 4.2.8.2.9.4.2 of LOC&PAS TSI.
- (3) Permissible materials for contact wires are copper and copper-alloy. The contact wire shall comply with the requirements of EN 50149:2012, clauses 4.2, (excluding the reference to annex B of the standard) 4.3 and 4.6 to 4.8.

#### 4.2.15. Phase separation sections

##### 4.2.15.1. General

- (1) The design of phase separation sections shall ensure that trains can move from one section to an adjacent one without bridging the two phases. Power consumption of the train (traction, auxiliaries and no-load current of the transformer) shall be brought

---

**Changes to legislation:** There are outstanding changes not yet made to Commission Regulation (EU) No 1301/2014. Any changes that have already been made to the legislation appear in the content and are referenced with annotations. (See end of Document for details) View outstanding changes

---

to zero before entering the phase separation section. Adequate means (except for the short separation section) shall be provided to allow a train that is stopped within the phase separation section to be restarted.

- (2) The overall length D of neutral sections is defined in EN 50367:2012, clause 4. For the calculation of D clearances in accordance to EN 50119:2009, clause 5.1.3 and an uplift of  $S_0$  shall be taken into account.

#### 4.2.15.2. Lines with speed $v \geq 250$ km/h

Two types of designs of phase separation sections may be adopted, either:

- (a) a phase separation design where all the pantographs of the longest TSI compliant trains are within the neutral section. The overall length of the neutral section shall be at least 402 m.

For detailed requirements see EN 50367:2012, Annex A.1.2, or

- (b) a shorter phase separation with three insulated overlaps as shown in EN 50367:2012, Annex A.1.4. The overall length of the neutral section is less than 142 m including clearances and tolerances.

#### 4.2.15.3. Lines with speed $v < 250$ km/h

The design of separation sections shall normally adopt solutions as described in EN 50367:2012, Annex A.1. Where an alternative solution is proposed, it shall be demonstrated that the alternative is at least as reliable.

### 4.2.16. System separation sections

#### 4.2.16.1. General

- (1) The design of system separation sections shall ensure that trains can move from one power supply system to an adjacent different power supply system without bridging the two systems. There are two methods for traversing system separation sections:
- (a) with pantograph raised and touching the contact wire;
  - (b) with pantograph lowered and not touching the contact wire.
- (2) The neighbouring Infrastructure Managers shall agree either (a) or (b) according to the prevailing circumstances.
- (3) The overall length D of neutral sections is defined in EN 50367:2012, clause 4. For the calculation of D clearances in accordance to EN 50119:2009, clause 5.1.3 and an uplift of  $S_0$  shall be taken into account.

#### 4.2.16.2. Pantographs raised

- (1) Power consumption of the train (traction, auxiliaries and no-load current of the transformer) shall be brought to zero before entering the system separation section.
- (2) If system separation sections are traversed with pantographs raised to the contact wire, their functional design is specified as follows:
- (a) the geometry of different elements of the overhead contact line shall prevent pantographs short-circuiting or bridging both power systems;

---

**Changes to legislation:** There are outstanding changes not yet made to Commission Regulation (EU) No 1301/2014. Any changes that have already been made to the legislation appear in the content and are referenced with annotations. (See end of Document for details) View outstanding changes

---

- (b) provision shall be made in the energy subsystem to avoid bridging of both adjacent power supply systems should the opening of the on-board circuit breaker(s) fail;
- (c) variation in contact wire height along the entire separation section shall fulfil requirements set in EN 50119:2009, clause 5.10.3.

#### 4.2.16.3. *Pantographs lowered*

- (1) This option shall be chosen if the conditions of operation with pantographs raised cannot be met.
- (2) If a system separation section is traversed with pantographs lowered, it shall be designed so as to avoid the electrical connection of the two power supply systems by an unintentionally raised pantograph.

#### [<sup>F</sup>4.2.17. *On-ground energy data collecting system*

- (1) Point 4.2.8.2.8 of LOC & PAS TSI contains the requirements for on-board Energy Measurement Systems (EMS) intended to produce and transmit the Compiled Energy Billing Data (CEBD) to an on-ground energy data collecting system.
- (2) The on-ground energy data collecting system (DCS) shall receive, store and export CEBD without corrupting it, in accordance with the requirements quoted in clause 4.12 of EN 50463-3:2017.
- (3) The on-ground energy DCS shall support all the data exchange requirements as defined in point 4.2.8.2.8.4 of the LOC&PAS TSI and requirements set out in clauses 4.3.6 and 4.3.7 of EN 50463-4:2017.]

#### 4.2.18. *Protective provisions against electric shock*

Electrical safety of the overhead contact line system and protection against electric shock shall be achieved by compliance with EN 50122-1:2011+A1:2011, clauses 5.2.1 (only for public areas), 5.3.1, 5.3.2, 6.1, 6.2 (excluding requirements for connections for track circuits) and regarding AC voltage limits for the safety of persons by compliance with 9.2.2.1 and 9.2.2.2 of the standard and regarding DC voltage limits by compliance with 9.3.2.1 and 9.3.2.2 of the standard.

### 4.3. **Functional and technical specifications of the interfaces**

#### 4.3.1. *General requirements*

From the standpoint of technical compatibility, the interfaces are listed in subsystem order as follows: rolling stock, infrastructure, control — command and signalling, and operation and traffic management.

#### 4.3.2. *Interface with Rolling Stock subsystem.*

Reference in the ENE TSI		Reference in the LOC & PAS TSI	
Parameter	Point	Parameter	Point
Voltage and frequency	4.2.3	Operation within range of voltages and frequencies	4.2.8.2.2

**Changes to legislation:** There are outstanding changes not yet made to Commission Regulation (EU) No 1301/2014. Any changes that have already been made to the legislation appear in the content and are referenced with annotations. (See end of Document for details) View outstanding changes

Parameters relating to supply system performance: — max train current — power factor of trains and the mean useful voltage	4.2.4	Max current from OCL Power factor	4.2.8.2.4 4.2.8.2.6
Current capacity, DC systems, trains at standstill	4.2.5	Maximum current at standstill	4.2.8.2.5
Regenerative braking	4.2.6	Regenerative brake with energy to OCL	4.2.8.2.3
Electrical protection coordination arrangements	4.2.7	Electrical protection of the train	4.2.8.2.10
Harmonics and dynamic effects for AC traction power supply systems	4.2.8	System energy disturbances for AC systems	4.2.8.2.7
Geometry of the overhead contact line	4.2.9	Working range in height of pantograph Pantograph head geometry	4.2.8.2.9.1 4.2.8.2.9.2
Pantograph gauge	4.2.10 Appendix D	Pantograph head geometry Gauging	4.2.8.2.9.2 4.2.3.1
Mean contact force	4.2.11	Pantograph static contact force	4.2.8.2.9.5
		Pantograph contact force and dynamic behaviour	4.2.8.2.9.6
Dynamic behaviour and quality of current collection	4.2.12	Pantograph contact force and dynamic behaviour	4.2.8.2.9.6
Pantograph spacing for overhead contact line design	4.2.13	Arrangements of pantographs	4.2.8.2.9.7
Contact wire material	4.2.14	Contact strip material	4.2.8.2.9.4
Separation sections: phase system	4.2.15 4.2.16	Running through phase or system separation section	4.2.8.2.9.8

**Changes to legislation:** There are outstanding changes not yet made to Commission Regulation (EU) No 1301/2014. Any changes that have already been made to the legislation appear in the content and are referenced with annotations. (See end of Document for details) View outstanding changes

On-ground energy data collecting system	4.2.17	On-board Energy measurement system	4.2.8.2.8
---	--------	------------------------------------	-----------

#### 4.3.3. *Interface with Infrastructure subsystem*

Reference in the ENE TSI		Reference in the INF TSI	
Parameter	Point	Parameter	Point
Pantographs gauge	4.2.10	Structure gauge	4.2.3.1

#### 4.3.4. *Interface with Control — Command and Signalling subsystems*

- (1) The interface for power control is an interface between the energy and the rolling stock subsystems.
- (2) However, the information is transmitted via the control-command and signalling subsystems and consequently the transmission interface is specified in the CCS TSI and the LOC & PAS TSI.
- (3) The relevant information to perform the switching of the circuit breaker, change of maximum train current, change of the power supply system and pantograph management shall be transmitted via ERTMS when the line is equipped with ERTMS.
- (4) Harmonic currents affecting control-command and signalling subsystems are set out in the CCS TSI.

#### 4.3.5. *Interface with Operation and traffic management subsystem*

Reference in the ENE TSI		Reference in the OPE TSI	
Parameter	Point	Parameter	Point
Maximum train current	4.2.4.1	Train composition Preparation of the Route Book	4.2.2.5 4.2.1.2.2.1
Separation sections: Phase System	4.2.15 4.2.16	Train composition Preparation of the Route Book	4.2.2.5 4.2.1.2.2.1

#### 4.4. **Operating rules**

- (1) [F1 Operating rules are developed within the procedures described in the infrastructure manager safety management system. These rules take into account the documentation related to operation, which forms a part of the technical file, as required in Article 15(4) and as set out in Annex IV of Directive (EU) 2016/797.]
- (2) In certain situations involving pre-planned works, it may be necessary to temporarily derogate from the specifications of the energy subsystem and its interoperability constituents defined in Sections 4 and 5 of the TSI.

#### 4.5. **Maintenance rules**



---

**Changes to legislation:** There are outstanding changes not yet made to Commission Regulation (EU) No 1301/2014. Any changes that have already been made to the legislation appear in the content and are referenced with annotations. (See end of Document for details) View outstanding changes

---

- (1) Maintenance rules are developed within the procedures described in the infrastructure manager safety management system.
- (2) The maintenance file for ICs and subsystem elements shall be prepared before placing a subsystem into service as the part of the technical file accompanying the declaration of verification.
- (3) The maintenance plan shall be drawn up for the subsystem to ensure that the requirements set out in this TSI are maintained during its lifetime.

#### 4.6. Professional qualifications

The professional qualifications of staff required for the operation and maintenance of the energy subsystem are covered by the procedures described in the infrastructure manager safety management system and are not set out in this TSI.

#### 4.7. Health and safety conditions

- (1) The health and safety conditions of staff required for the operation and maintenance of the energy subsystem shall be compliant with the relevant European and national legislation.
- (2) This issue is also covered by the procedures described in the infrastructure manager safety management system.

### 5. INTEROPERABILITY CONSTITUENTS

#### 5.1. List of constituents

- (1) The interoperability constituents are covered by the relevant provisions of [F1 Directive (EU) 2016/797] and they are listed here below for the energy subsystem.
- (2) Overhead contact line:
  - (a) The interoperability constituent overhead contact line consists of the components listed below to be installed within an energy subsystem and the associated design and configuration rules.
  - (b) The components of an overhead contact line are an arrangement of wire(s) suspended over the railway line for supplying electricity to electric trains, together with associated fittings, in-line insulators and other attachments including feeders and jumpers. It is placed above the upper limit of the vehicle gauge, supplying vehicles with electrical energy through pantographs.
  - (c) The supporting components such as cantilevers, masts and foundations, return conductors, auto-transformer feeders, switches and other insulators are not part of the interoperability constituent overhead contact line. They are covered by subsystem requirements so far as interoperability is concerned.
- (3) The conformity assessment shall cover the phases and characteristics as indicated in point 6.1.4 and by X in the Table A.1 of Appendix A to this TSI.

#### 5.2. Constituents' performances and specifications

##### 5.2.1. Overhead contact line

##### 5.2.1.1. Geometry of the OCL

---

**Changes to legislation:** There are outstanding changes not yet made to Commission Regulation (EU) No 1301/2014. Any changes that have already been made to the legislation appear in the content and are referenced with annotations. (See end of Document for details) View outstanding changes

---

The design of the overhead contact line shall comply with point 4.2.9.

#### 5.2.1.2. Mean contact force

The overhead contact line shall be designed by using the mean contact force  $F_m$  stipulated in point 4.2.11.

#### 5.2.1.3. Dynamic behaviour

Requirements for dynamic behaviour of the overhead contact line are set out in point 4.2.12.

#### 5.2.1.4. Space for steady arm uplift

The overhead contact line shall be designed providing the required space for uplift as set out in point 4.2.12.

#### 5.2.1.5. Pantograph spacing for overhead contact line design

The overhead contact line shall be designed for pantograph spacing as specified in point 4.2.13.

#### [<sup>F2</sup>5.2.1.6. Current at standstill (DC systems only)]

For DC systems, the overhead contact line shall be designed for the requirements set out in point 4.2.5.

#### 5.2.1.7. Contact wire material

The contact wire material shall comply with the requirements set out in point 4.2.14.

## 6. ASSESSMENT OF CONFORMITY OF THE INTEROPERABILITY CONSTITUENTS AND EC VERIFICATION OF THE SUBSYSTEMS

Modules for the procedures for assessment of conformity, suitability for use and EC verification modules are described in the Commission Decision 2010/713/EU.

### 6.1. Interoperability constituents

#### 6.1.1. Conformity assessment procedures

- (1) The conformity assessment procedures of interoperability constituents as defined in Section 5 of this TSI shall be carried out by application of relevant modules.
- (2) Assessment procedures for particular requirements for interoperability constituent are set out in point 6.1.4.

#### 6.1.2. Application of modules

- (1) The following modules for conformity assessment of interoperability constituents are used:

(a) CA	Internal production control
(b) CB	EC type examination
(c) CC	Conformity to type based on internal production control
(d) CH	Conformity based on full quality management system
(e) CH1	Conformity based on full quality management system plus design examination

---

**Changes to legislation:** There are outstanding changes not yet made to Commission Regulation (EU) No 1301/2014. Any changes that have already been made to the legislation appear in the content and are referenced with annotations. (See end of Document for details) View outstanding changes

---

Table 6.1.2

**Modules for conformity assessment to be applied for ICs**

Procedures	Modules
Placed on the EU market before entry in force of this TSI	CA or CH
Placed on the EU market after entry in force of this TSI	CB + CC or CH1

- (2) The modules for conformity assessment of interoperability constituents shall be chosen from those shown in Table 6.1.2.
- (3) In the case of products placed on the market before the publication of relevant TSIs, the type is considered to have been approved and therefore EC type examination (module CB) is not necessary, provided that the manufacturer demonstrates that tests and verification of interoperability constituents have been considered successful for previous applications under comparable conditions and are in conformity with the requirements of this TSI. In this case these assessments shall remain valid in the new application. If it is not possible to demonstrate that the solution is positively proven in the past, the procedure for ICs placed on the EU market after publication of this TSI applies.

6.1.3. *Innovative solutions for interoperability constituents*

If an innovative solution is proposed for an interoperability constituent, the procedure described in Article 10 of this Regulation shall apply.

6.1.4. *Particular assessment procedure for the interoperability constituent — overhead contact line*6.1.4.1. *Assessment of dynamic behaviour and quality of current collection*

- (1) Methodology:
- (a) The assessment of the dynamic behaviour and the quality of the current collection involves the overhead contact line (energy subsystem) and the pantograph (rolling stock subsystem).
- (b) Compliance with the requirements on dynamic behaviour shall be verified by assessment of:
- Contact wire uplift
  - and either:
  - Mean contact force  $F_m$  and standard deviation  $\sigma_{max}$
  - or
  - Percentage of arcing
- (c) The Contracting Entity shall declare the method to be used for verification.
- (d) The design of overhead contact line shall be assessed with a simulation tool validated according with EN 50318:2002 and by measurement according to EN 50317:2012.

---

**Changes to legislation:** There are outstanding changes not yet made to Commission Regulation (EU) No 1301/2014. Any changes that have already been made to the legislation appear in the content and are referenced with annotations. (See end of Document for details) View outstanding changes

---

- (e) If an existing OCL design has been in operation for at least 20 years, then the requirement for simulation defined in the point (2) is optional. The measurement as defined in point (3) shall be carried out for the worst case arrangements of the pantographs regarding the interaction performance of this particular OCL design.
- (f) The measurement can be conducted on a specially constructed test section or on a line where the overhead contact line is under construction.

(2) Simulation:

- (a) For the purposes of simulation and analysis of the results, representative features (for example tunnels, crossovers, neutral sections etc.) shall be taken into account.
- (b) The simulations shall be made using at least two different TSI compliant types of pantograph for the appropriate speed<sup>(1)</sup> and supply system, up to the design speed of the proposed interoperability constituent overhead contact line.
- (c) It is allowed to perform the simulation using types of pantograph that are under the process of IC certification, provided that they fulfil the other requirements of LOC&PAS TSI.
- (d) The simulation shall be performed for single pantograph and multiple pantographs with spacing according to the requirements set in point 4.2.13.
- (e) In order to be acceptable, the simulated current collection quality shall be in accordance with point 4.2.12 for uplift, mean contact force and standard deviation for each of the pantographs.

(3) Measurement:

- (a) If the simulation results are acceptable, a site dynamic test with a representative section of the new overhead contact line shall be undertaken.
- (b) This measurement can be done before putting into service or under full operation conditions.
- (c) For the above mentioned site test, one of the two types of the pantograph chosen for the simulation shall be installed on a rolling stock that allows the appropriate speed on the representative section.
- (d) The tests shall be performed at least for the worst case arrangements of the pantographs regarding the interaction performance derived from the simulations. If it is not possible to test using spacing between pantographs of 8 m, then it is permissible, for tests at speeds of up to 80 km/h, to increase the spacing between two consecutive pantographs to up to 15 m.
- (e) The mean contact force of each pantograph shall fulfil the requirements of the point 4.2.11 up to envisaged design speed of the OCL under test.
- (f) In order to be acceptable, the measured current collection quality shall be in accordance with point 4.2.12, for uplift, and either the mean contact force and standard deviation or percentage of arcing.

---

**Changes to legislation:** There are outstanding changes not yet made to Commission Regulation (EU) No 1301/2014. Any changes that have already been made to the legislation appear in the content and are referenced with annotations. (See end of Document for details) View outstanding changes

---

- (g) If all the above assessments are passed successfully, the tested overhead contact line design shall be considered to be compliant and may be used on lines where the characteristics of the design are compatible.
- (h) Assessment of dynamic behaviour and quality of current collection for interoperability constituent pantograph is set out in the point 6.1.3.7 of the LOC & PAS TSI.

#### [<sup>F2</sup>6.1.4.2. Assessment of current at standstill (DC systems only)]

The conformity assessment shall be carried out in accordance with EN 50367:2012, Annex A.3 for the static force defined in point 4.2.5.

#### 6.1.5. EC declaration of conformity of interoperability constituent OCL

According to Annex IV, Section 3 of Directive 2008/57/EC, the EC declaration of conformity shall be accompanied by statement setting out the condition of use:

- (a) maximum design speed;
- (b) nominal voltage and frequency;
- (c) [<sup>F2</sup>continuous current rating;]
- (d) accepted pantograph profile.

### 6.2. Energy subsystem

#### 6.2.1. General provisions

- (1) [<sup>F1</sup>At the request of the applicant, the notified body carries out EC verification in accordance with Article 15 of Directive (EU) 2016/797 and in accordance with the provisions of the relevant modules.]
- (2) If the applicant demonstrates that tests or verifications of an energy subsystem have been successful for previous applications of a design in similar circumstances, the notified body shall take these tests and verifications into account for the EC verification.
- (3) Assessment procedures for particular requirements for subsystem are set out in point 6.2.4.
- (4) [<sup>F1</sup>The applicant shall draw up the EC declaration of verification for the energy subsystem in accordance with Article 15(1) of and Annex IV to Directive (EU) 2016/797.]

#### 6.2.2. Application of modules

For the EC verification procedure of the energy subsystem, the applicant or its authorised representative established within the Community may choose either:

- (a) Module SG: EC verification based on unit verification, or
- (b) Module SH1: EC verification based on full quality management system plus design examination.

##### 6.2.2.1. Application of module SG

---

**Changes to legislation:** There are outstanding changes not yet made to Commission Regulation (EU) No 1301/2014. Any changes that have already been made to the legislation appear in the content and are referenced with annotations. (See end of Document for details) View outstanding changes

---

In case of module SG, the notified body may take into account evidence of examinations, checking or tests that have been successfully performed under comparable conditions by other bodies or by (or on behalf of) the applicant.

#### 6.2.2.2. *Application of module SH1*

The module SH1 may be chosen only where the activities contributing to the proposed subsystem to be verified (design, manufacturing, assembling, installation) are subject to a quality management system for design, production, final product inspection and testing, approved and surveyed by a notified body.

#### 6.2.3. *Innovative solutions*

If an innovative solution is proposed for the energy subsystem, the procedure described in Article 10 of this Regulation shall apply.

#### 6.2.4. *Particular assessment procedures for energy subsystem*

##### 6.2.4.1. *Assessment of mean useful voltage*

- (1) The assessment shall be demonstrated in accordance with EN 50388:2012, clause 15.4.
- (2) The assessment shall be demonstrated only in the case of newly build or upgraded sub-systems.

##### 6.2.4.2. *Assessment of regenerative braking*

- (1) The assessment for AC power supply fixed installations shall be demonstrated according to EN 50388:2012, clause 15.7.2.
- (2) The assessment for DC power supply shall be demonstrated by a design review.

##### 6.2.4.3. *Assessment of electrical protection coordination arrangements*

The assessment shall be demonstrated for design and operation of substations in accordance with EN 50388:2012, clause 15.6.

##### 6.2.4.4. *Assessment of harmonics and dynamic effects for AC traction power supply systems*

- (1) A compatibility study shall be carried out according to EN 50388:2012, clause 10.3.
- (2) This study shall be carried out only in the case of introducing converters with active semi-conductors in the power supply system.
- (3) The notified body shall assess if criteria of EN 50388:2012, clause 10.4 are fulfilled.

##### 6.2.4.5. *Assessment of dynamic behaviour and quality of current collection (integration into a subsystem)*

- (1) The main goal of this test is to identify allocation design and construction errors but not to assess the basic design in principle.
- (2) Measurements of the interaction parameters shall be carried out in accordance with EN 50317:2012.
- (3) These measurements shall be carried out with an interoperability constituent pantograph, exhibiting the mean contact force characteristics as required by point 4.2.11 of this TSI for the design speed of the line considering aspects related to minimum speed and siding tracks.

---

**Changes to legislation:** There are outstanding changes not yet made to Commission Regulation (EU) No 1301/2014. Any changes that have already been made to the legislation appear in the content and are referenced with annotations. (See end of Document for details) View outstanding changes

---

- (4) The installed overhead contact line shall be accepted if the measurement results comply with the requirements in point 4.2.12.
- (5) For operational speeds up to 120 km/h (AC systems) and up to 160 km/h (DC systems), measurement of the dynamic behaviour is not mandatory. In this case alternative methods of identifying construction errors shall be used, such as measurement of OCL geometry according to point 4.2.9.
- (6) Assessment of dynamic behaviour and quality of current collection for integration of the pantograph into rolling stock subsystem are set out in point 6.2.3.20 of LOC & PAS TSI.

#### 6.2.4.6. *Assessment of the protective provisions against electric shock*

- (1) For each installation it shall be demonstrated that the basic design of protective provisions against electric shock is in accordance with point 4.2.18.
- (2) In addition the existence of rules and procedures which ensure that the installation is installed as designed shall be checked.

#### 6.2.4.7. *Assessment of maintenance plan*

- (1) The assessment shall be carried out by verifying the existence of the maintenance plan.
- (2) The notified body is not responsible for assessing the suitability of the detailed requirements set out in the plan.

### 6.3. **Sub-system containing interoperability constituents not holding an EC declaration**

#### 6.3.1. *Conditions*

- (1) Until 31 May 2021, a notified body is allowed to issue an EC certificate of verification for a subsystem, even if some of the interoperability constituents incorporated within the subsystem are not covered by the relevant EC declarations of conformity and/or suitability for use according to this TSI, if the following criteria are complied with:
  - (a) the conformity of the subsystem has been checked against the requirements of Section 4 and in relation to points 6.2 and 6.3 and Section 7, except point 7.4, of this TSI by the notified body. Furthermore the conformity of the ICs to Section 5 and point 6.1 does not apply, and
  - (b) the interoperability constituents, which are not covered by the relevant EC declaration of conformity and/or suitability for use, have been used in a subsystem already approved and put in service in at least one of the Member State before the entry in force of this TSI.
- (2) EC Declarations of conformity and/or suitability for use shall not be drawn up for the interoperability constituents assessed in this manner.

#### 6.3.2. *Documentation*

- (1) The EC certificate of verification of the subsystem shall indicate clearly which interoperability constituents have been assessed by the notified body as part of the subsystem verification.
- (2) The EC declaration of verification of the subsystem shall indicate clearly:

---

**Changes to legislation:** There are outstanding changes not yet made to Commission Regulation (EU) No 1301/2014. Any changes that have already been made to the legislation appear in the content and are referenced with annotations. (See end of Document for details) View outstanding changes

---

- (a) which interoperability constituents have been assessed as part of the subsystem,
- (b) confirmation that the subsystem contains the interoperability constituents identical to those verified as part of the subsystem,
- (c) <sup>[F1]</sup>for those interoperability constituents, the reason(s) why the manufacturer did not provide an EC declaration of conformity and/or suitability for use before its incorporation into the subsystem, including the application of national rules notified under Article 13 of Directive (EU) 2016/797.]

### 6.3.3. Maintenance of the subsystems certified according to 6.3.1

- (1) During and after the transition period and until the subsystem is upgraded or renewed (taking into account the decision of Member State on application of TSIs), the interoperability constituents which do not hold an EC declaration of conformity and/or suitability for use and are of the same type are allowed to be used as maintenance related replacements (spare parts) for the subsystem, under the responsibility of the body responsible for maintenance.
- (2) In any case the body responsible for maintenance must ensure that the components for maintenance related replacements are suitable for their applications, are used within their area of use, and enable interoperability to be achieved within the rail system while at the same time meeting the essential requirements. Such components must be traceable and certified in accordance with any national or international rule, or any code of practice widely acknowledged in the railway domain.

## 7. IMPLEMENTATION OF THE ENERGY TSI

<sup>[F1]</sup>Member States shall develop a national plan for the implementation of this TSI, considering the coherence of the entire rail system of the European Union. This plan shall include all projects regarding new, renewal and upgrading of energy subsystem, in line with the details mentioned in points 7.1 to 7.4 here below.]

### 7.1. Application of this TSI to railway lines

Sections 4 to 6 and any specific provisions in points 7.2 to 7.3 here below apply in full to the lines within the geographical scope of this TSI, which will be placed in service as interoperable lines after this TSI enters into force.

### 7.2. Application of this TSI to new, renewed or upgraded railway lines

#### 7.2.1. Introduction

- (1) For the purpose of this section, a ‘new line’ means a line that creates a route where none currently exists.
- (2) The following situations may be considered as an upgrade or renewal of existing lines:
  - (a) the realignment of part of an existing route;
  - (b) the creation of a bypass;
  - (c) the addition of one or more tracks on an existing route, regardless of the distance between the original tracks and the additional tracks.
- (3) <sup>[F4]</sup> . . . . .]



---

**Changes to legislation:** There are outstanding changes not yet made to Commission Regulation (EU) No 1301/2014. Any changes that have already been made to the legislation appear in the content and are referenced with annotations. (See end of Document for details) [View outstanding changes](#)

---

### Textual Amendments

**F4** Deleted by Commission Implementing Regulation (EU) 2019/776 of 16 May 2019 amending Commission Regulations (EU) No 321/2013, (EU) No 1299/2014, (EU) No 1301/2014, (EU) No 1302/2014, (EU) No 1303/2014 and (EU) 2016/919 and Commission Implementing Decision 2011/665/EU as regards the alignment with Directive (EU) 2016/797 of the European Parliament and of the Council and the implementation of specific objectives set out in Commission Delegated Decision (EU) 2017/1474 (Text with EEA relevance).

#### 7.2.2. *Implementation plan for voltage and frequency*

- (1) The choice of power supply system is a Member State's competence. The decision should be taken on economic and technical grounds, taking into account at least the following elements:
- (a) the existing power supply system in the Member State;
  - (b) any connection to railway line in neighbouring countries with an existing electrical power supply;
  - (c) power demand.
- (2) New lines with speed greater than 250 km/h shall be supplied with one of the AC systems as defined in point 4.2.3.

#### 7.2.3. *Implementation plan for OCL geometry*

##### 7.2.3.1. *Scope of the implementation plan*

Member States' implementation plan shall take into account the following elements:

- (a) closing gaps between different OCL geometries;
- (b) any connection to the existing OCL geometries in neighbouring areas;
- (c) existing certified ICs OCL.

##### 7.2.3.2. *Implementation rules for 1 435 mm track gauge system*

The OCL shall be designed taking into account the following rules:

- (a) New lines with speed greater than 250 km/h shall accommodate both pantographs as specified in the LOC & PAS TSI points 4.2.8.2.9.2.1 (1 600 mm) and 4.2.8.2.9.2.2 (1 950 mm).  
If this is not possible, the OCL shall be designed for use by at least a pantograph with the head geometry specified in the LOC & PAS TSI point 4.2.8.2.9.2.1 (1 600 mm).
- (b) Renewed or upgraded lines with speed equal or greater than 250 km/h shall accommodate at least a pantograph with the head geometry specified in the LOC & PAS TSI point 4.2.8.2.9.2.1 (1 600 mm).
- (c) Other cases: the OCL shall be designed for use by at least one of the pantographs with the head geometry specified in the LOC & PAS TSI points 4.2.8.2.9.2.1 (1 600 mm) or 4.2.8.2.9.2.2 (1 950 mm).

##### 7.2.3.3. *Track gauge systems different than 1 435mm*

---

**Changes to legislation:** There are outstanding changes not yet made to Commission Regulation (EU) No 1301/2014. Any changes that have already been made to the legislation appear in the content and are referenced with annotations. (See end of Document for details) View outstanding changes

---

The OCL shall be designed for use by at least one of the pantographs with the head geometry specified in the LOC & PAS TSI point 4.2.8.2.9.2.

[<sup>F2</sup>7.2.4. By 1 January 2022, Member States shall ensure that an on-ground energy data collecting system capable to exchange compiled energy billing data in accordance with point 4.2.17 of this TSI is implemented.]

### 7.3. Application of this TSI to existing lines

#### [<sup>F1</sup>7.3.1. Introduction

In case this TSI shall apply to existing lines and without prejudice to point 7.4 (specific cases), the following elements shall be considered:

- (a) The scope of the upgrading or renewal of the energy subsystem may cover the entire subsystem on a given line or only certain parts of the subsystem. In accordance with Article 18(6) of Directive (EU) 2016/797 the national safety authority shall examine the project and decide whether a new authorisation for placing in service is needed.
- (b) Where a new authorisation is required, parts of the energy subsystem falling under the scope of the upgrading or renewal shall comply with this TSI and shall be subject to the procedure established in Article 15 of Directive (EU) 2016/797, unless a permission for non-application of TSI is granted according to Article 7 of Directive (EU) 2016/797.
- (c) Where a new authorisation for placing in service is required, the Contracting Entity shall define the practical measures and different phases of the project, which are necessary to achieve the required levels of performance. These project phases may include transition periods for placing equipment into service with reduced levels of performance.
- (d) Where a new authorisation for placing in service is not required, compliance with this TSI is recommended. Where compliance is not possible, the contracting entity shall inform the Member State of the reasons thereof.]

#### 7.3.2. Upgrading/renewal of the OCL and/or the power supply

- (1) It is possible to gradually modify all or part of the OCL and/or the power supply system — element by element — over an extended period of time to achieve compliance with this TSI.
- (2) [<sup>F4</sup> . . . . .]
- (3) The process of upgrading/renewal should take into consideration the need of maintaining compatibility with the existing energy subsystem and other subsystems. For a project including elements not being TSI compliant, the procedures for the assessment of conformity and EC verification to be applied should be agreed with the Member State.

#### 7.3.3. Parameters related to maintenance

While maintaining the energy subsystem, formal verifications and authorisations for placing into service are not required. However, maintenance replacements may be undertaken, as far as reasonably practicable, in accordance with the requirements of this TSI contributing to the development of interoperability.

---

**Changes to legislation:** There are outstanding changes not yet made to Commission Regulation (EU) No 1301/2014. Any changes that have already been made to the legislation appear in the content and are referenced with annotations. (See end of Document for details) View outstanding changes

---

[<sup>F2</sup>7.3.4. The procedure to be used for the demonstration of the level of compliance of existing lines with the basic parameters of this TSI shall be in accordance with Recommendation 2014/881/EU.]

[<sup>F5</sup>7.3.5. *Route compatibility checks before the use of authorised vehicles*

The procedure to be applied and the parameters of the energy subsystem to be used by the railway undertaking, for the purpose of route compatibility check are described in point 4.2.2.5 and appendix D1 of the Annex to Commission Implementing Regulation (EU) 2019/773<sup>(2)</sup>.]

#### Textual Amendments

**F5** Inserted by Commission Implementing Regulation (EU) 2019/776 of 16 May 2019 amending Commission Regulations (EU) No 321/2013, (EU) No 1299/2014, (EU) No 1301/2014, (EU) No 1302/2014, (EU) No 1303/2014 and (EU) 2016/919 and Commission Implementing Decision 2011/665/EU as regards the alignment with Directive (EU) 2016/797 of the European Parliament and of the Council and the implementation of specific objectives set out in Commission Delegated Decision (EU) 2017/1474 (Text with EEA relevance).

## 7.4. Specific cases

[<sup>F1</sup>7.4.1. *General*

- (1) The specific cases, as listed in point 7.4.2, describe special provisions that are needed and authorised on particular networks of each Member State.
- (2) These specific cases are classified as:
  - ‘P’ cases: ‘permanent’ cases,
  - ‘T’ cases: ‘temporary’ cases, where the target system shall be reached by 31 December 2035.

All specific cases and their relevant dates shall be re-examined in the course of future revisions of the TSI with a view to limiting their technical and geographical scope based on an assessment of their impact on safety, interoperability, cross border services, TEN-T corridors, and the practical and economic impacts of retaining or eliminating them. Special account shall be given to availability of EU funding.

Specific cases shall be limited to the route or network where they are strictly necessary and taken account of through route compatibility procedures.]

7.4.2. *List of specific cases*

7.4.2.1. *Particular features on the Estonian network*

7.4.2.1.1. Voltage and frequency (4.2.3)

P case

Maximum allowed voltage of overhead contact line in Estonia is 4 kV (3 kV DC networks).

7.4.2.2. *Particular features on the French network*

7.4.2.2.1. Voltage and frequency (4.2.3)

T case

The values and limits of the voltage and frequency at the terminals of the substation and at the pantograph of the 1,5 kV DC electrified lines:

---

**Changes to legislation:** There are outstanding changes not yet made to Commission Regulation (EU) No 1301/2014. Any changes that have already been made to the legislation appear in the content and are referenced with annotations. (See end of Document for details) View outstanding changes

---

- Nimes to Port Bou,
- Toulouse to Narbonne,

may extend the values set out in EN50163:2004, clause 4 ( $U_{\max 2}$  close to 2 000 V).

7.4.2.2.2. Phase separation sections — lines with speed  $v \geq 250$  km/h (4.2.15.2)  
P case

In case of upgrading/renewal of high speed lines LN 1, 2, 3 and 4 special design of phase separation sections is allowed.

7.4.2.3. *Particular features on the Italian network*

7.4.2.3.1. Phase separation sections — lines with speed  $v \geq 250$  km/h (4.2.15.2)  
P case

In case of upgrading/renewal of high speed line Rome-Naples special design of phase separation sections is allowed.

7.4.2.4. *Particular features on the Latvian network*

7.4.2.4.1. Voltage and frequency (4.2.3)  
P case

Maximum allowed voltage of overhead contact line in Latvia is 4 kV (3 kV DC networks).

7.4.2.5. *Particular features on the Lithuanian network*

7.4.2.5.1. Dynamic behaviour and quality of current collection (4.2.12)  
P case

For existing overhead contact line designs the space for steady arm uplift is calculated according to national technical rules notified for this purpose.

7.4.2.6. *Particular features on the Polish network*

7.4.2.6.1. Electrical protection coordination arrangements (4.2.7)  
P case

For Polish DC 3 kV network the note c in the table 7 of the standard EN 50388: 2012 is replaced by note: The tripping of the circuit breaker should be very rapid for high short-circuits currents. As far as possible, the traction unit circuit breaker should trip in order to try to avoid the substation circuit breaker tripping.

7.4.2.7. *Particular features on the Spanish network*

7.4.2.7.1. Contact wire height (4.2.9.1)  
P case

On some sections of the future lines  $v \geq 250$  km/h the nominal contact height is allowed 5,60 m.

7.4.2.7.2. Phase separation sections — lines with speed  $v \geq 250$  km/h (4.2.15.2)  
P case

In case of upgrading/renewal of existing high speed lines special design of phase separation sections shall be kept.

7.4.2.8. *Particular features on the Swedish network*

7.4.2.8.1. Assessment of mean useful voltage (6.2.4.1)

---

**Changes to legislation:** There are outstanding changes not yet made to Commission Regulation (EU) No 1301/2014. Any changes that have already been made to the legislation appear in the content and are referenced with annotations. (See end of Document for details) View outstanding changes

---

## P case

Alternatively to assessment of mean useful voltage according to EN 50388:2012, clause 15.4, the power supply performance is also allowed to be assessed by:

- A comparison with a reference where the power supply solution has been used for a similar or more demanding train schedule. The reference shall have a similar or larger:
  - distance to the voltage controlled bus bar (frequency converter station),
  - impedance of the OCL system.
- A rough estimation of  $U_{\text{mean useful}}$  for simple cases resulting in an increased additional capacity for future traffic demands.

### 7.4.2.9. Particular features on the UK network for Great Britain

#### 7.4.2.9.1. Voltage and frequency (4.2.3)

##### P case

It is permissible to continue to upgrade, renew and extend networks equipped with the electrification system operating at 600/750 V DC and utilising conductor rails in a three and/or four rail configuration in accordance with the national technical rules notified for this purpose.

Specific case for the United Kingdom of Great Britain and Northern Ireland, applying only to the mainline network in Great Britain.

#### 7.4.2.9.2. Contact wire height (4.2.9.1)

##### P case

For new, upgrade or renewal of the energy subsystem on existing infrastructure it is allowed to design the overhead contact line wire height in accordance with the national technical rules notified for this purpose.

Specific case for the United Kingdom of Great Britain and Northern Ireland, applying only to the mainline network in Great Britain.

#### 7.4.2.9.3. Maximum lateral deviation (4.2.9.2) and pantograph gauge (4.2.10)

##### P case

For new, upgrade or renewal of the energy subsystem on existing infrastructure it is allowed to calculate the adjustment to the maximum lateral deviation, the verification heights, and pantograph gauge in accordance with the national technical rules notified for this purpose.

Specific case for the United Kingdom of Great Britain and Northern Ireland, applying only to the mainline network in Great Britain.

#### 7.4.2.9.4. Protective provisions against electric shock (4.2.18)

##### P case

For upgrade or renewal of the existing energy subsystem or the construction of new energy subsystems on existing infrastructure, in place of the reference to EN50122-1:2011+A1:2011 clause 5.2.1, it is allowed to design the protective provisions against electric shock in accordance with the national technical rules notified for this purpose.

Specific case for the United Kingdom of Great Britain and Northern Ireland, applying only to the mainline network in Great Britain.

#### 7.4.2.9.5. Conformity assessment of OCL as component

##### P case

---

**Changes to legislation:** There are outstanding changes not yet made to Commission Regulation (EU) No 1301/2014. Any changes that have already been made to the legislation appear in the content and are referenced with annotations. (See end of Document for details) [View outstanding changes](#)

---

The national rules may define the procedure for conformity related to points 7.4.2.9.2 and 7.4.2.9.3 and associated certificates.

The procedure may include the conformity assessment of parts which are not subject to a specific case.

7.4.2.10. *Particular features on the Eurotunnel network*

7.4.2.10.1 Contact wire height (4.2.9.1)

P case

For, upgrade or renewal of the existing energy subsystem it is allowed for the overhead contact line wire height to be designed in accordance with the technical rules notified for this purpose.

<sup>F3</sup>7.4.2.11. *Particular features on the Luxembourgish network*

.....

**Changes to legislation:** There are outstanding changes not yet made to Commission Regulation (EU) No 1301/2014. Any changes that have already been made to the legislation appear in the content and are referenced with annotations. (See end of Document for details) View outstanding changes

## Appendix A

### Conformity assessment of interoperability constituents

#### A.1 SCOPE

This Appendix indicates the conformity assessment of interoperability constituent (overhead contact line) of the energy subsystem.

For existing interoperability constituents, the process described in point 6.1.2. shall be followed.

#### A.2 CHARACTERISTICS

The characteristics of the interoperability constituent to be assessed applying modules CB or CH1 are marked by an X in Table A.1. The production phase shall be assessed within the subsystem.

TABLE A.1

#### Assessment of the interoperability constituent: overhead contact line

Characteristic point	Assessment in the following phase			Production phase Product quality(series production)
	Design and development phase			
	Design review	Manufacturing process review	Test <sup>b</sup>	
Geometry of the OCL — 5.2.1.1	X	N/A	N/A	N/A
Mean contact force — 5.2.1.2 <sup>a</sup>	X	N/A	N/A	N/A
Dynamic behaviour — 5.2.1.3	X	N/A	X	N/A
Space for steady arm uplift — 5.2.1.4	X	N/A	X	N/A
Pantograph spacing for overhead contact line design — 5.2.1.5	X	N/A	N/A	N/A
Current at standstill — 5.2.1.6	X	N/A	X	N/A

<sup>a</sup> The measurement of the contact force is integrated with the process of assessment of dynamic behaviour and quality of current collection.

<sup>b</sup> Test as defined in Section 6.1.4. on particular assessment procedure for the interoperability constituent — overhead contact line.

N/A : not applicable

---

**Changes to legislation:** There are outstanding changes not yet made to Commission Regulation (EU) No 1301/2014. Any changes that have already been made to the legislation appear in the content and are referenced with annotations. (See end of Document for details) [View outstanding changes](#)

---

Contact wire material — 5.2.1.7	X	N/A	N/A	N/A
<b>a</b>	The measurement of the contact force is integrated with the process of assessment of dynamic behaviour and quality of current collection.			
<b>b</b>	Test as defined in Section 6.1.4. on particular assessment procedure for the interoperability constituent — overhead contact line.			
N/A	: not applicable			

---



**Changes to legislation:** There are outstanding changes not yet made to Commission Regulation (EU) No 1301/2014. Any changes that have already been made to the legislation appear in the content and are referenced with annotations. (See end of Document for details) View outstanding changes

## Appendix B

### EC verification of the energy subsystem

#### B.1 SCOPE

This Appendix indicates the EC verification of the energy subsystem.

#### B.2 CHARACTERISTICS

The characteristics of the subsystem to be assessed in the different phases of design, installation and operation are marked by X in Table B.1.

TABLE B.1

#### EC verification of the energy subsystem

Basic parameters	Assessment phase			
	Design develop. phase	Production phase		
	Design review	Construction, assembly, mounting	Assembled, before putting into service	Validation under full operating conditions
Voltage and frequency — 4.2.3	X	N/A	N/A	N/A
Parameters relating to supply system performance — 4.2.4	X	N/A	N/A	N/A
Current capacity, DC systems, trains at standstill — 4.2.5	X <sup>a</sup>	N/A	N/A	N/A
Regenerative braking — 4.2.6	X	N/A	N/A	N/A
Electrical protection coordination	X	N/A	X	N/A
<b>a</b>	Only to be carried out if the overhead contact line has not been assessed as interoperability constituent.			
<b>b</b>	Validation under full operating conditions shall only be done when the validation in the phase ‘Assembly before putting into service’ is not possible.			
<b>c</b>	To be carried out as an alternative assessment method in case the dynamic behaviour of the OCL integrated into subsystem is not measured (see point 6.2.4.5)			
<b>d</b>	To be carried out in case the check is not done by another independent body.			
N/A	: not applicable			

**Changes to legislation:** There are outstanding changes not yet made to Commission Regulation (EU) No 1301/2014. Any changes that have already been made to the legislation appear in the content and are referenced with annotations. (See end of Document for details) View outstanding changes

arrangements — 4.2.7				
Harmonics and dynamic effects for AC traction power supply systems- 4.2.8	X	N/A	N/A	N/A
Geometry of the overhead contact line — 4.2.9	X <sup>a</sup>	N/A	N/A <sup>c</sup>	N/A
Pantograph gauge — 4.2.10	X	N/A	N/A	N/A
Mean contact force — 4.2.11	X <sup>a</sup>	N/A	N/A	N/A
Dynamic behaviour and quality of current collection — 4.2.12	X <sup>a</sup>	N/A	X <sup>bc</sup>	N/A <sup>b</sup>
Pantograph spacing for overhead contact line design — 4.2.13	X <sup>a</sup>	N/A	N/A	N/A
Contact wire material — 4.2.14	X <sup>a</sup>	N/A	N/A	N/A
Phase separation sections — 4.2.15	X	N/A	N/A	N/A
System separation sections — 4.2.16	X	N/A	N/A	N/A
On-ground energy data collecting system — 4.2.17	N/A	N/A	N/A	N/A

**a** Only to be carried out if the overhead contact line has not been assessed as interoperability constituent.

**b** Validation under full operating conditions shall only be done when the validation in the phase ‘Assembly before putting into service’ is not possible.

**c** To be carried out as an alternative assessment method in case the dynamic behaviour of the OCL integrated into subsystem is not measured (see point 6.2.4.5)

**d** To be carried out in case the check is not done by another independent body.

N/A : not applicable

---

**Changes to legislation:** There are outstanding changes not yet made to Commission Regulation (EU) No 1301/2014. Any changes that have already been made to the legislation appear in the content and are referenced with annotations. (See end of Document for details) View outstanding changes

---

Protective provisions against electric shock — 4.2.18	X	X <sup>d</sup>	X <sup>d</sup>	N/A
Maintenance rules — 4.5	N/A	N/A	X	N/A
<b>a</b>	Only to be carried out if the overhead contact line has not been assessed as interoperability constituent.			
<b>b</b>	Validation under full operating conditions shall only be done when the validation in the phase ‘Assembly before putting into service’ is not possible.			
<b>c</b>	To be carried out as an alternative assessment method in case the dynamic behaviour of the OCL integrated into subsystem is not measured (see point 6.2.4.5)			
<b>d</b>	To be carried out in case the check is not done by another independent body.			
N/A	: not applicable			

---

**Changes to legislation:** There are outstanding changes not yet made to Commission Regulation (EU) No 1301/2014. Any changes that have already been made to the legislation appear in the content and are referenced with annotations. (See end of Document for details) View outstanding changes

---

## Appendix C

### Mean useful voltage

#### C.1 VALUES FOR U MEAN USEFUL AT THE PANTOGRAPH

The minimum values for mean useful voltage at the pantograph under normal operating conditions shall be as given in Table C.1.

TABLE C.1

#### Minimum U mean useful at pantograph

Power supply system	V	
	Line speed $v > 200$ [km/h]	Line speed $v \leq 200$ [km/h]
	Zone and train	Zone and train
AC 25 kV 50 Hz	22 500	22 000
AC 15 kV 16,7 Hz	14 200	13 500
DC 3 kV	2 800	2 700
DC 1,5 kV	1 300	1 300

#### C.2 SIMULATION RULES

Zone used for simulation to calculate  $U_{\text{mean useful}}$

- Simulations shall be carried out on a zone which represents a significant part of a line or a part of the network, such as the relevant feeding section(s) in the network for the object to be designed and assessed.

Time period used for simulation to calculate  $U_{\text{mean useful}}$

- For simulation of  $U_{\text{mean useful}}$  (train) and  $U_{\text{mean useful}}$  (zone) only trains that are part of the simulation during a relevant time, such as the time needed to go through a complete feeding section, have to be considered.

---

**Changes to legislation:** There are outstanding changes not yet made to Commission Regulation (EU) No 1301/2014. Any changes that have already been made to the legislation appear in the content and are referenced with annotations. (See end of Document for details) View outstanding changes

---

## Appendix D

### Specification of the pantograph gauge

#### D.1 SPECIFICATION OF THE MECHANICAL KINEMATIC PANTOGRAPH GAUGE

##### D.1.1 General

###### D.1.1.1 Space to be cleared for electrified lines

In the case of lines electrified by an overhead contact line, an additional space should be cleared:

- to accommodate the OCL equipment,
- to allow the free passage of the pantograph.

This Appendix deals with the free passage of the pantograph (pantograph gauge). The electrical clearance is considered by the Infrastructure Manager.

###### D.1.1.2 Particularities

The pantograph gauge differs in some aspects from the obstacle gauge:

- The pantograph is (partly) live and, for this reason, an electrical clearance is to be complied with, according to the nature of the obstacle (insulated or not),
- The presence of insulating horns should be taken into account, where necessary. Therefore a double reference contour has to be defined to take account of the mechanical and electrical interference simultaneously,
- In collecting condition, the pantograph is in permanent contact with the contact wire and, for this reason, its height is variable. So is the height of the pantograph gauge.

###### D.1.1.3 Symbols and abbreviations

Symbol	Designation	Unit
$b_w$	Half-length of the pantograph bow	m
$b_{w,c}$	Half-length of the pantograph bow conducting length (with insulating horns) or working length (with conducting horns)	m
$b'_{o,mec}$	Width of mechanical kinematic pantograph gauge at upper verification point	m
$b'_{u,mec}$	Width of mechanical kinematic pantograph gauge at lower verification point	m
$b'_{h,mec}$	Width of mechanical kinematic pantograph gauge at intermediate height, h	m

Subscript a : refers to the outside of the curve  
Subscript i : refers to the inside of the curve

---

**Changes to legislation:** There are outstanding changes not yet made to Commission Regulation (EU) No 1301/2014. Any changes that have already been made to the legislation appear in the content and are referenced with annotations. (See end of Document for details) View outstanding changes

$d_l$	Lateral deviation of contact wire	m
$D'_0$	Reference cant taken into account by the vehicle for the pantograph gauge	m
$e_p$	Pantograph sway due to the vehicle characteristics	m
$e_{po}$	Pantograph sway at the upper verification point	m
$e_{pu}$	Pantograph sway at the lower verification point	m
$f_s$	Margin to take account of the raising of the contact wire	m
$f_{wa}$	Margin to take account of the wear of the pantograph contact strip	m
$f_{ws}$	Margin to take account of the bow trespassing the contact wire due to the pantograph sway	m
$h$	Height in relation to the running surface	m
$h'_{co}$	Reference roll centre height for the pantograph gauge	m
$h'$	Reference height in the calculation of the pantograph gauge	m
$h'_o$	Maximum verification height of the pantograph gauge in a collecting position	m
$h'_u$	Minimum verification height of the pantograph gauge in a collecting position	m
$h_{eff}$	Effective height of the raised pantograph	m
$h_{cc}$	Static height of the contact wire	m
$I'_0$	Reference cant deficiency taken into account by the vehicle for the pantograph gauging	m

Subscript a : refers to the outside of the curve  
Subscript i : refers to the inside of the curve

**Changes to legislation:** There are outstanding changes not yet made to Commission Regulation (EU) No 1301/2014. Any changes that have already been made to the legislation appear in the content and are referenced with annotations. (See end of Document for details) View outstanding changes

$L$	Distance between rail centres of a track	m
$l$	Track gauge, distance between the rail running edges	m
$q$	Transverse play between axle and bogie frame or, for vehicles not fitted with bogies, between axle and vehicle body	m
$qs'$	Quasi-static movement	m
$R$	Horizontal curve radius	m
$s'_o$	Flexibility coefficient taken into account by agreement between the vehicle and the infrastructure for the pantograph gauging	
$S'_{i/a}$	Allowed additional overthrow on the inside/ outside of the curve for pantographs	m
$w$	Transverse play between bogie and body	m
$[\sum_j^{X1}]$	Sum of the (horizontal) safety margins covering some random phenomena ( $j = 1, 2$ or $3$ ) for the pantograph gauge	m]
Subscript a	: refers to the outside of the curve	
Subscript i	: refers to the inside of the curve	

#### Editorial Information

**X1** Substituted by [Corrigendum to Commission Regulation \(EU\) No 1301/2014 of 18 November 2014 on the technical specifications for interoperability relating to the 'energy' subsystem of the rail system in the Union \(Official Journal of the European Union L 356 of 12 December 2014\)](#).

#### D.1.1.4 Basic principles

#### $f^2$ Figure Pantograph mechanical gauges

##### D.1

**Changes to legislation:** There are outstanding changes not yet made to Commission Regulation (EU) No 1301/2014. Any changes that have already been made to the legislation appear in the content and are referenced with annotations. (See end of Document for details) View outstanding changes

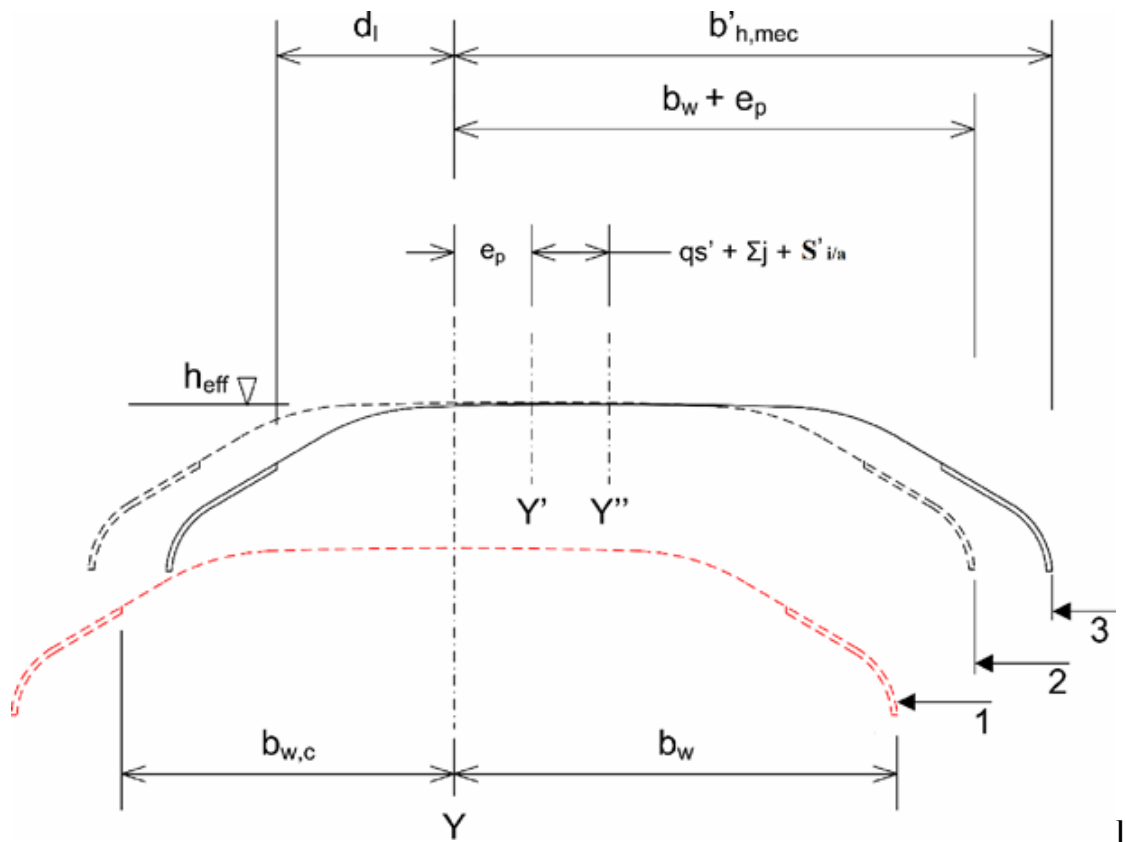

**Caption:**

Y	: Centre line of the track
Y'	: Centre line of the pantograph — for deriving the free passage reference profile
Y''	: Centre line of the pantograph — for deriving the mechanical kinematic pantograph gauge
1	: Pantograph profile
2	: Free passage reference profile
3	: Mechanical kinematic gauge

The pantograph gauge is only met if the mechanical and electrical gauges are complied with simultaneously:

- The free passage reference profile includes the pantograph collector head length and the pantograph sway  $e_p$ , which applies up to the reference cant or cant deficiency,
- Live and insulated obstacles shall remain outside the mechanical gauge,
- Non insulated obstacles (earthed or at a potential different from the OCL) shall remain outside the mechanical and electrical gauges.

## D.1.2 Specification of the mechanical kinematic pantograph gauge

### D.1.2.1 Specification of the width of the mechanical gauge

#### D.1.2.1.1 Scope

The width of the pantograph gauge is mainly specified by the length and displacements of the pantograph under consideration. Beyond specific phenomena, phenomena similar to those of the obstacle gauge are found in the transverse displacements.



---

**Changes to legislation:** There are outstanding changes not yet made to Commission Regulation (EU) No 1301/2014. Any changes that have already been made to the legislation appear in the content and are referenced with annotations. (See end of Document for details) View outstanding changes

---

The pantograph gauge shall be considered at the following heights:

- The upper verification height  $h'_o$
- The lower verification height  $h'_u$

Between those two heights, it can be considered that gauge width varies in a linear way.

The various parameters are shown in figure D.2.

#### D.1.2.1.2 Calculation methodology

The pantograph gauge width shall be specified by the sum of the parameters defined below. In the case of a line run by various pantographs, the maximum width should be considered.

For the lower verification point with  $h = h'_u$ :

$$b_{u(i/a),mec} = (b_w + e_{pu} + St_{i/a} + qst_{i/a} + \sum_j)_{\max}$$

For the upper verification point with  $h = h'_o$ :

$$b_{o(i/a),mec} = (b_w + e_{po} + St_{i/a} + qst_{i/a} + \sum_j)_{\max}$$

Note i/a = inside/outside curve.

For any intermediate height  $h$ , width is specified by means of an interpolation:

$$b_{h,mec} = b_{u,mec} + \frac{h-h_u}{h_o-h_u} \times (b_{o,mec} - b_{u,mec})$$

#### D.1.2.1.3 Half-length $b_w$ of the pantograph bow

The half-length  $b_w$  of the pantograph bow depends on the type of pantograph used. The pantograph profile(s) to be considered are defined in LOC&PAS TSI, point 4.2.8.2.9.2.

#### D.1.2.1.4 Pantograph sway $ep$

The sway mainly depends on the following phenomena:

- Play  $q + w$  in the axle boxes and between bogie and body.
- The amount of body inclination taken into account by the vehicle (depending on the specific flexibility  $s_0'$ , the reference cant  $D'_0$  and the reference cant deficiency  $I'_0$ ).
- The mounting tolerance of the pantograph on the roof.
- The transverse flexibility of the mounting device on the roof.
- The height under consideration  $h'$ .

Figure D.2

**Changes to legislation:** There are outstanding changes not yet made to Commission Regulation (EU) No 1301/2014. Any changes that have already been made to the legislation appear in the content and are referenced with annotations. (See end of Document for details) View outstanding changes

### Specification of the width of the mechanical kinematic gauge of the pantograph at different heights

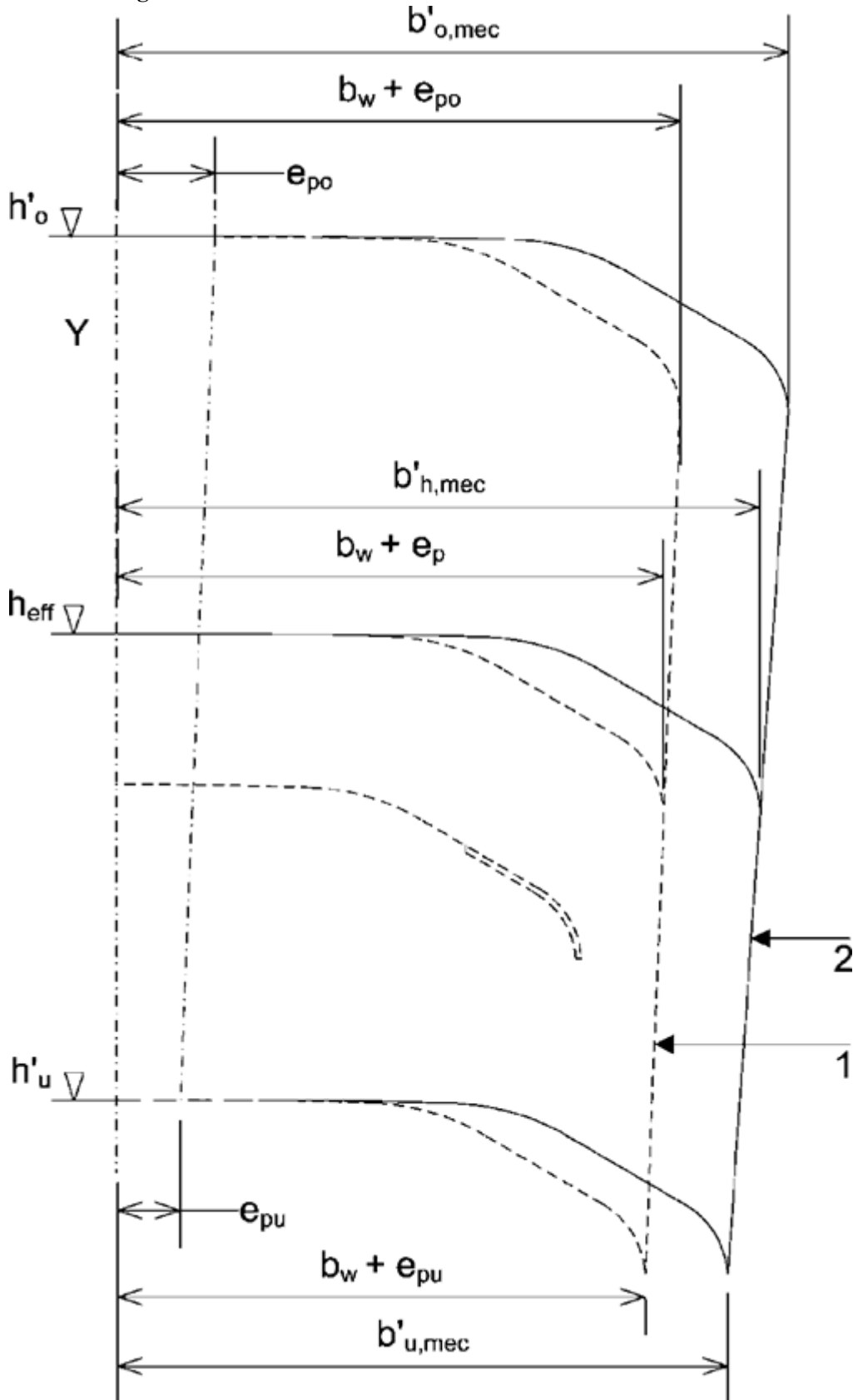

---

**Changes to legislation:** There are outstanding changes not yet made to Commission Regulation (EU) No 1301/2014. Any changes that have already been made to the legislation appear in the content and are referenced with annotations. (See end of Document for details) View outstanding changes

---

#### D.1.2.1.5 Additional overthrows

The pantograph gauge has a specific additional overthrows. In case of standard track gauge the following formula applies:

$$S'_{i/a} = \frac{2,5}{R} + \frac{\ell - 1,435}{2}$$

For other track gauges the national rules apply.

#### D.1.2.1.6 Quasi-static effect

Since the pantograph is installed on the roof, the quasi-static effect plays an important role in the calculation of the pantograph gauge. That effect is calculated from the specific flexibility  $s'_0$ , reference cant  $D'_0$  and reference cant deficiency  $I'_0$ :

$$qs'_i = \frac{s'_0}{L} [D - D'_0]_{>0} (h - h'_{c0})$$

$$qs'_a = \frac{s'_0}{L} [I - I'_0]_{>0} (h - h'_{c0})$$

*Note:* Pantographs are normally mounted on the roof of a power unit, whose reference flexibility  $s'_0$  is generally smaller than that of the obstacle gauge  $s_0$ .

#### D.1.2.1.7 Allowances

According to gauge definition, the following phenomena should be considered:

- Loading dissymmetry;
- The transverse displacement of the track between two successive maintenance actions;
- The cant variation occurring between two successive maintenance actions;
- Oscillations generated by track unevenness.

[<sup>XI</sup>The sum of the abovementioned allowances is covered by  $\Sigma_j$ .]

#### D.1.2.2 Specification of the height of the mechanical gauge

Gauge height shall be specified on the basis of the static height  $h_{cc}$ , of the contact wire at the local point under consideration. The following parameters should be considered:

- The raising  $f_s$  of the contact wire generated by the pantograph contact force. The value of  $f_s$  depends on the OCL type and so shall be specified by the Infrastructure Manager in accordance with point 4.2.12.
- The raising of the pantograph head due to the pantograph head skew generated by the staggered contact point and the wear of the collector strip  $f_{ws} + f_{wa}$ . The permissible value of  $f_{ws}$  is shown in LOC & PAS TSI and  $f_{wa}$  depends on maintenance requirements.

The height of the mechanical gauge is given by the following formula:

$$h_{eff} = h_{cc} + f_s + f_{ws} + f_{wa}$$

#### D.1.3 Reference parameters

Parameters for the kinematic mechanical pantograph gauge and for Specification of the maximum lateral deviation of the contact wire shall be as follows:

- $l$  — according to track gauge
- $s'_0 = 0,225$
- $h'_{c0} = 0,5$  m
- $I'_0 = 0,066$  m and  $D'_0 = 0,066$  m

**Changes to legislation:** There are outstanding changes not yet made to Commission Regulation (EU) No 1301/2014. Any changes that have already been made to the legislation appear in the content and are referenced with annotations. (See end of Document for details) View outstanding changes

—  $h'_o = 6,500 \text{ m}$  and  $h'_u = 5,000 \text{ m}$

**D.1.4 Calculation of maximum lateral deviation of contact wire**

The maximum lateral deviation of the contact wire shall be calculated by taking into consideration the total movement of the pantograph with respect to the nominal track position and the conducting range (or working length, for pantographs without horns made from a conducting material) as follows:

$$\int^{X1} d_t = b_{w,c} + b_w - b_{h,mec}$$

$b_{w,c}$  — defined in points 4.2.8.2.9.1 and 4.2.8.2.9.2 of LOC&PAS TSI

**D.2 SPECIFICATION OF THE STATIC PANTOGRAPH GAUGE (TRACK GAUGE SYSTEM 1 520 mm)**

This is applicable for Member States accepting the pantograph profile in accordance with LOC&PAS TSI point 4.2.8.2.9.2.3.

The pantograph gauge shall conform to Figure D.3 and Table D.1.  
*Figure D.3*

**Static pantograph gauge for 1 520mm track gauge system**

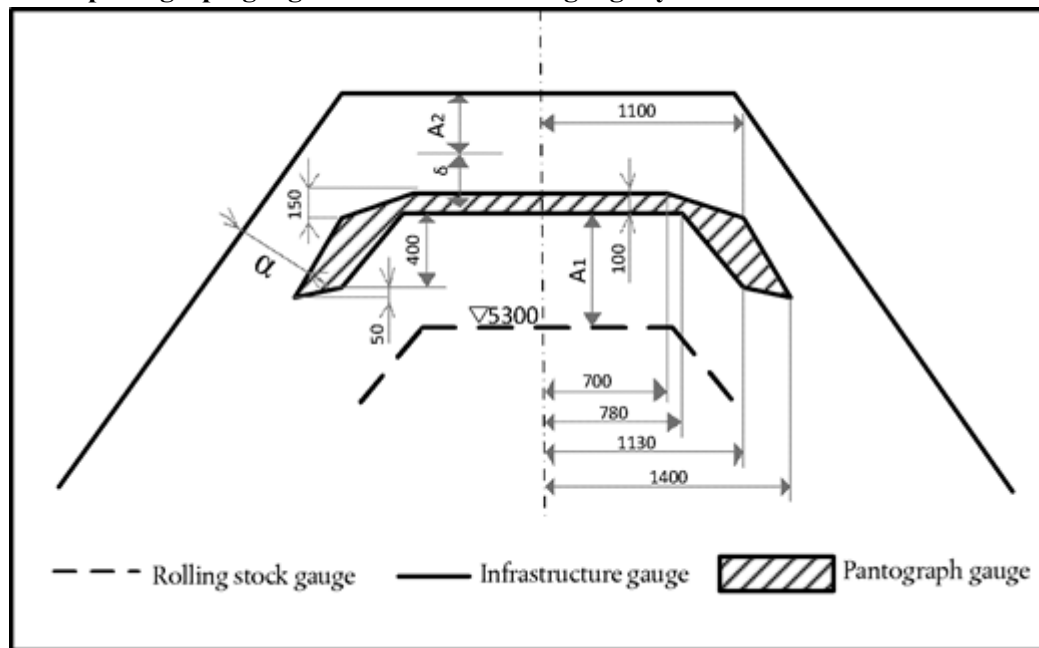

TABLE D.1

**Distances between live parts of OCL and pantograph and earthed parts of rolling stock and fixed instalations for 1 520mm track gauge system**

Voltage of the contact	Vertical air clearance $A_1$ between the rolling stock and lowest	Vertical air clearance $A_2$ between live parts of	Lateral air clearance $\alpha$ between live parts	Vertical space $\delta$ for the live parts of the OCL (mm)
------------------------	---	--	---	--

**Changes to legislation:** There are outstanding changes not yet made to Commission Regulation (EU) No 1301/2014. Any changes that have already been made to the legislation appear in the content and are referenced with annotations. (See end of Document for details) View outstanding changes

system in respect of the ground [kV]	position of the contact wire [mm]		OCL and earthed parts [mm]		of the pantograph and earthed parts [mm]		Without catenary wire		With catenary wire		
	Normal		Minimal allowed for	Normal	Minimal allowed	Normal	Minimal allowed	Normal	Minimal allowed	Normal	Minimal allowed
	Plain and main station tracks on which train hoteling is not foreseen	Other station tracks	plain and main station tracks on which train hoteling is not foreseen	Normal	Minimal allowed	Normal	Minimal allowed	Normal	Minimal allowed	Normal	Minimal allowed
<b>1</b>	<b>2</b>	<b>3</b>	<b>4</b>	<b>5</b>	<b>6</b>	<b>7</b>	<b>8</b>	<b>9</b>	<b>10</b>	<b>11</b>	<b>12</b>
1,5-4	450	950	250	200	150	200	150	150	100	300	250
6-12	450	950	300	250	200	220	180	150	100	300	250
25	450	950	375	350	300	250	200	150	100	300	250

**Changes to legislation:** There are outstanding changes not yet made to Commission Regulation (EU) No 1301/2014. Any changes that have already been made to the legislation appear in the content and are referenced with annotations. (See end of Document for details) View outstanding changes

## Appendix E

### List of referenced standards

TABLE E.1

#### List of referenced standards

Index No.	Reference	Document name	Version	BP(s) concerned
1	EN 50119	Railway applications — Fixed installations — Electric traction overhead contact lines	2009	<i>Current capacity, DC systems, trains at standstill (4.2.5), Geometry of overhead contact line (4.2.9), Dynamic behaviour and quality of current collection (4.2.12), Phase separation sections (4.2.15) and System separation sections (4.2.16)</i>
2	EN 50122-1:2011+A1:2011	Railway applications — Fixed installations — Electrical safety, earthing and the return circuit — Part 1: Protective provisions against electric shock	2011	<i>Geometry of the overhead contact line (4.2.9) and Protective provisions against electric shock (4.2.18)</i>
3	EN 50149	Railway applications — Fixed installations — Electric traction — Copper and copper alloy grooved contact wires	2012	<i>Contact wire material (4.2.14)</i>
4	EN 50163	Railway applications — Supply voltages	2004	<i>Voltage and frequency (4.2.3)</i>

**Changes to legislation:** There are outstanding changes not yet made to Commission Regulation (EU) No 1301/2014. Any changes that have already been made to the legislation appear in the content and are referenced with annotations. (See end of Document for details) View outstanding changes

		of traction systems		
5	EN 50367	Railway applications — Current collection systems — Technical criteria for the interaction between pantograph and overhead line (to achieve free access)	2012	<i>Current capacity, DC systems, trains at standstill (4.2.5), Mean contact force (4.2.11), Phase separation sections (4.2.15) and System separation sections (4.2.16)</i>
6	EN 50388	Railway applications — Power supply and rolling stock — Technical criteria for the coordination between power supply (substation) and rolling stock to achieve interoperability	2012	<i>Parameters relating to supply system performance (4.2.4), Electrical protection coordination arrangements (4.2.7), Harmonics and dynamic effects for AC systems (4.2.8)</i>
7	EN 50317	Railway applications — Current collection systems — Requirements for and validation of measurements of the dynamic interaction between pantograph and overhead contact line	2012	<i>Assessment of dynamic behaviour and quality of current collection (6.1.4.1 and 6.2.4.5)</i>
8	EN 50318	Railway applications — Current collection systems — Validation of simulation of	2002	<i>Assessment of dynamic behaviour and quality of current collection (6.1.4.1)</i>

---

**Changes to legislation:** There are outstanding changes not yet made to Commission Regulation (EU) No 1301/2014. Any changes that have already been made to the legislation appear in the content and are referenced with annotations. (See end of Document for details) View outstanding changes

---

		the dynamic interaction between pantograph and overhead contact line		
[ <sup>F69</sup>	EN 50463-3	Railway application — Energy measurement on board trains — Part 3: Data handling	2017	<i>On-ground energy data collecting system (4.2.17)</i>
10	EN 50463-4	Railway application — Energy measurement on board trains — Part 4: Communication	2017	<i>On-ground energy data collecting system (4.2.17)]</i>



**Changes to legislation:** *There are outstanding changes not yet made to Commission Regulation (EU) No 1301/2014. Any changes that have already been made to the legislation appear in the content and are referenced with annotations. (See end of Document for details) [View outstanding changes](#)*

---

## Appendix F

### List of open points

[<sup>F2</sup>Intentionally deleted]

**Changes to legislation:** There are outstanding changes not yet made to Commission Regulation (EU) No 1301/2014. Any changes that have already been made to the legislation appear in the content and are referenced with annotations. (See end of Document for details) View outstanding changes

## Appendix G

### Glossary

TABLE G.1

#### Glossary

Defined term	Abbr.	Definition
AC		Alternative current
DC		Direct current
Compiled energy billing data	CEBD	Dataset compiled by the Data Handling System (DHS) suitable for energy billing
Contact line system		System that distributes the electrical energy to the trains running on the route and transmits it to the trains by means of current collectors
Contact force		Vertical force applied by the pantograph to the OCL
Contact wire uplift		Vertical upward movement of the contact wire due to the force produced from the pantograph
Current collector		Equipment fitted to the vehicle and intended to collect current from a contact wire or conductor rail
Gauge		Set of rules including a reference contour and its associated calculation rules allowing defining the outer dimensions of the vehicle and the space to be cleared by the infrastructure. NOTE: According to the calculation method implemented, the gauge will be a static, kinematic or dynamic
Lateral deviation		Lateral stagger of contact wire in maximum crosswind.
Level crossing		An intersection at the same elevation of a road and one or more rail tracks

**Changes to legislation:** There are outstanding changes not yet made to Commission Regulation (EU) No 1301/2014. Any changes that have already been made to the legislation appear in the content and are referenced with annotations. (See end of Document for details) View outstanding changes

Line speed		Maximum speed measured in kilometres per hour for which a line has been designed
Maintenance plan		A series of documents setting out the infrastructure maintenance procedures adopted by an infrastructure manager
Mean contact force		Statistical mean value of the contact force
Mean useful voltage train		Voltage identifying the dimensioning train and enables the effect on its performance to be quantified
Mean useful voltage zone		Voltage giving an indication of the quality of the power supply in a geographic zone during the peak traffic period in the timetable
Minimum contact wire height		A minimum value of the contact wire height in the span in order to avoid the arcing between one or more contact wires and vehicles in all conditions
[ <sup>F3</sup> ]		
Nominal contact wire height		A nominal value of the contact wire height at a support in the normal conditions
Nominal voltage		Voltage by which an installation or part of an installation is designated
Normal service		Planned timetable service
On-ground energy data collecting system (data collecting service)	DCS	On-ground service collecting the CEBD from an Energy Measurement System
Overhead contact line	OCL	Contact line placed above (or beside) the upper limit of the vehicle gauge and supplying vehicles with electric energy through roof-mounted current collection equipment
Reference contour		A contour, associated to each gauge, showing the shape of a cross-section and used as a

---

**Changes to legislation:** There are outstanding changes not yet made to Commission Regulation (EU) No 1301/2014. Any changes that have already been made to the legislation appear in the content and are referenced with annotations. (See end of Document for details) [View outstanding changes](#)

---

		basis to work out the sizing rules of the infrastructure, on the one hand and of the vehicle, on the other hand
Return circuit		All conductors which form the intended path for the traction return current
Static contact force		Mean vertical force exerted upwards by the pantograph head on the OCL, and caused by the pantograph-raising device, whilst the pantograph is raised and the vehicle is standstill

---

**Changes to legislation:** There are outstanding changes not yet made to Commission Regulation (EU) No 1301/2014. Any changes that have already been made to the legislation appear in the content and are referenced with annotations. (See end of Document for details) [View outstanding changes](#)

---

- (1) i.e. the speed of the two types of pantograph shall be at least equal to the design speed of the simulated overhead contact line.
- (2) [<sup>F5</sup>Commission Implementing Regulation (EU) 2019/773 of 16 May 2019 on the technical specification for interoperability relating to the operation and traffic management subsystem of the rail system within the European Union and repealing Decision 2012/757/EU (OJ L 139 I, 27.5.2019, p. 5).]

---

#### **Textual Amendments**

- F5** Inserted by Commission Implementing Regulation (EU) 2019/776 of 16 May 2019 amending Commission Regulations (EU) No 321/2013, (EU) No 1299/2014, (EU) No 1301/2014, (EU) No 1302/2014, (EU) No 1303/2014 and (EU) 2016/919 and Commission Implementing Decision 2011/665/EU as regards the alignment with Directive (EU) 2016/797 of the European Parliament and of the Council and the implementation of specific objectives set out in Commission Delegated Decision (EU) 2017/1474 (Text with EEA relevance).

**Changes to legislation:**

There are outstanding changes not yet made to Commission Regulation (EU) No 1301/2014. Any changes that have already been made to the legislation appear in the content and are referenced with annotations.

[View outstanding changes](#)

**Changes and effects yet to be applied to :**

- Regulation revoked by [S.I. 2020/318 Sch. 2](#)
- Recital 6 Text repeal by [EUR 2018/868 Regulation](#)