

This document is meant purely as a documentation tool and the institutions do not assume any liability for its contents

► **B**

COMMISSION REGULATION (EU) No 1302/2014

of 18 November 2014

concerning a technical specification for interoperability relating to the ‘rolling stock — locomotives and passenger rolling stock’ subsystem of the rail system in the European Union

(Text with EEA relevance)

(OJ L 356, 12.12.2014, p. 228)

Corrected by:

► **C1** Corrigendum, OJ L 10, 16.1.2015, p. 45 (1302/2014)

**COMMISSION REGULATION (EU) No 1302/2014****of 18 November 2014****concerning a technical specification for interoperability relating to the ‘rolling stock — locomotives and passenger rolling stock’ subsystem of the rail system in the European Union****(Text with EEA relevance)**

THE EUROPEAN COMMISSION,

Having regard to the Treaty on the Functioning of the European Union,

Having regard to Directive 2008/57/EC of the European Parliament and of the Council of 17 June 2008 on the interoperability of the rail system within the Community⁽¹⁾, and in particular Article 6(1) second subparagraph thereof,

Whereas:

- (1) Article 12 of Regulation (EC) No 881/2004 of the European Parliament and of the Council⁽²⁾ establishing a European Railway Agency (Agency Regulation) requires the European Railway Agency (hereinafter ‘the Agency’) to ensure that the technical specifications for interoperability (hereinafter the ‘TSIs’) are adapted to technical progress, market trends and social requirements and to propose to the Commission the amendments to the TSIs which it considers necessary.
- (2) By Decision C(2010) 2576 of 29 April 2010, the Commission gave the Agency a mandate to develop and review the TSI's with a view to extending their scope to the whole rail system in the Union. Under the terms of that mandate, the Agency was requested to extend the scope of the TSI relating to the subsystem ‘rolling stock — locomotives and passenger rolling stock’, to the whole rail system in the Union.
- (3) On 12 December 2012, the Agency issued a recommendation on the revised TSI relating to the subsystem ‘rolling stock — locomotives and passenger rolling stock’.
- (4) In order to follow technological evolution and encourage modernisation, innovative solutions should be promoted and their implementation should, under certain conditions, be allowed. Where an innovative solution is proposed, the manufacturer or his authorised representative should state how they deviate from or how they complement to the relevant section of the TSI, and the innovative solution should be assessed by the Commission. If this assessment is positive, the Agency should define the appropriate functional and interface specifications of the innovative solution and develop the relevant assessment methods.

⁽¹⁾ OJ L 191, 18.7.2008, p. 1.

⁽²⁾ Regulation (EC) No 881/2004 of the European Parliament and of the Council of 29 April 2004 establishing a European Railway Agency (OJ L 164, 30.4.2004, p. 1).

▼B

- (5) The TSI on rolling stock established by this Regulation does not deal with all essential requirements. In accordance with Article 5(6) of Directive 2008/57/EC, technical aspects which are not covered by it should be identified as ‘open points’ governed by national rules applicable in each Member State.
- (6) In accordance with Article 17(3) of Directive 2008/57/EC, Member States are to notify the Commission and other Member States the technical rules, the conformity assessment and verification procedures to be used for the specific cases, and the bodies responsible for carrying out these procedures. The same obligation should be provided as regards to open points.
- (7) Rolling stock currently operates under existing national, bilateral, multinational or international agreements. It is important that these agreements do not hinder current and future progress towards interoperability. The Member States should therefore notify such agreements to the Commission.
- (8) In accordance with Article 11(5) of Directive 2008/57/EC, the TSI on rolling stock should allow, for a limited period of time, for interoperability constituents to be incorporated into subsystems without certification if certain conditions are met.
- (9) Commission Decisions 2008/232/EC ⁽¹⁾ and 2011/291/EU ⁽²⁾ should therefore be repealed.
- (10) In order to prevent unnecessary additional costs and administrative burden, Decisions 2008/232/EC and 2011/291/EU should continue to apply after their repeal to the subsystems and projects referred to in Article 9(1)(a) of Directive 2008/57/EC.
- (11) The measures provided for in this Regulation are in accordance with the opinion of the Committee established in accordance with Article 29(1) of Directive 2008/57/EC,

HAS ADOPTED THIS REGULATION:

Article 1

The technical specification for interoperability (TSI) relating to the ‘rolling stock — locomotives and passengers rolling stock’ subsystem of the rail system in the entire European Union, as set out in the Annex, is hereby adopted.

⁽¹⁾ Commission Decision 2008/232/EC of 21 February 2008 concerning a technical specification for interoperability relating to the rolling stock subsystem of the trans-European high speed rail system (OJ L 84, 26.3.2008, p. 132).

⁽²⁾ Commission Decision 2011/291/EU of 26 April 2011 concerning a technical specification for interoperability relating to the rolling stock subsystem — ‘Locomotives and passenger rolling stock’ of the trans-European conventional rail system (OJ L 139, 26.5.2011, p. 1).

▼B*Article 2*

1. The TSI shall apply to the ‘rolling stock’ subsystem as described in point 2.7 of Annex II to Directive 2008/57/EC which is, or is intended to be, operated on the rail network defined in point 1.2 of the Annex and which falls under one of the following types:

- (a) self-propelling thermal or electric trains;
- (b) thermal or electric traction units;
- (c) passenger carriages;
- (d) mobile railway infrastructure construction and maintenance equipment.

2. The TSI shall apply to the rolling stock referred to in paragraph 1 which is intended to be operated on one or more of the following nominal track gauges: 1 435 mm, 1 520 mm, 1 524 mm, 1 600 mm and 1 668 mm, as stated in Section 2.3.2 of the Annex.

Article 3

1. Without prejudice to Articles 8 and 9, and point 7.1.1 of the Annex, the TSI shall apply to all new rolling stock of the rail system in the Union, defined in Article 2(1), which is placed in service from 1 January 2015.

2. The TSI shall not apply to existing rolling stock of the rail system in the European Union which is already placed in service on all or part of the network of any Member State on 1 January 2015, except when it is subject to renewal or upgrading in accordance with Article 20 of Directive 2008/57/EC and Section 7.1.2 of the Annex.

3. The technical and geographical scope of this Regulation is set out in Sections 1.1 and 1.2 of the Annex.

4. The fitment of the on-board energy measurement system defined in clause 4.2.8.2.8 of the Annex is mandatory for new, upgraded and renewed vehicles intended to be operated on networks equipped with the on-ground energy data collecting system (DCS) defined in point 4.2.17 of Commission Regulation (EU) No 1301/2014 ⁽¹⁾.

Article 4

1. With regard to the aspects classified as ‘open points’ set out in Appendix I of the Annex to this Regulation, the conditions to be complied with for verifying the interoperability pursuant to Article 17(2) of Directive 2008/57/EC shall be those national rules applicable in the Member State which authorises the placing in service of the subsystem covered by this Regulation.

⁽¹⁾ Commission Regulation (EU) No 1301/2014 of 18 November 2014 on the technical specifications for interoperability relating to the ‘energy’ subsystem of the rail system in the Union (See page 179 of this Official Journal).

▼B

2. Within six months of the entry into force of this Regulation, each Member State shall send to the other Member States and the Commission the following information, unless such information has already been sent to them under Commission Decisions 2008/232/EC or 2011/291/EU:

- (a) the national rules referred to in paragraph 1;
- (b) the conformity assessment and verification procedures to be carried out to apply the national rules referred to in paragraph 1;
- (c) the bodies designated in accordance with Article 17(3), of Directive 2008/57/EC to carry out the conformity assessment and verification procedures with respect to the open points.

Article 5

1. With regard to specific cases listed in Section 7.3 of the Annex to this Regulation, the conditions to be met for the verification of interoperability pursuant to Article 17(2) of Directive 2008/57/EC shall be the national rules applicable in the Member State which authorise the placing in service of the subsystem covered by this Regulation.

2. Within six months of the entry into force of this Regulation, each Member State shall notify the other Member States and to the Commission with:

- (a) the national rules referred to in paragraph 1;
- (b) the conformity assessment and verification procedures to be carried out to apply the national rules referred to in paragraph 1;
- (c) the bodies designated in accordance with Article 17(3), of Directive 2008/57/EC to carry out the conformity assessment and verification procedures in the specific cases set out in Section 7.3 of the Annex.

Article 6

1. Without prejudice to the agreements which have already been notified under Decision 2008/232/EC, and shall not be notified again, Member States shall notify the Commission, within six months of the entry into force of this Regulation, any existing national, bilateral, multilateral or international agreements under which the rolling stock within the scope of this Regulation is operated.

2. Member States shall forthwith notify the Commission with any future agreements or modifications of existing agreements.

Article 7

In accordance with Article 9(3) of Directive 2008/57/EC, each Member State shall communicate to the Commission within one year of the entry into force of this Regulation the list of projects being implemented within its territory and are at an advanced stage of development.

▼B*Article 8*

1. An ‘EC’ certificate of verification for a subsystem that contains interoperability constituents which do not have an ‘EC’ declaration of conformity or suitability for use may be issued during a transitional period ending on 31 May 2017 provided the provisions laid down in Section 6.3 of the Annex are met.
2. The production or upgrade/renewal of the subsystem using non-certified interoperability constituents shall be completed within the transitional period set out in paragraph 1, including the placing in service.
3. During the transitional period set out in paragraph 1:
 - (a) the reasons for non-certification of any interoperability constituents shall be properly identified by the notified body before granting the ‘EC’ certificate pursuant to Article 18 of Directive 2008/57/EC;
 - (b) the national safety authorities, pursuant to Article 16(2)(c) of Directive 2004/49/EC of the European Parliament and of the Council ⁽¹⁾, shall report on the use of non-certified interoperability constituents in the context of authorisation procedures in their annual report referred to in Article 18 of Directive 2004/49/EC.
4. After one year from the entry into force of this Regulation, newly produced interoperability constituents shall be covered by the ‘EC’ declaration of conformity or suitability for use.

Article 9

The declaration of verification of a subsystem referred to in Articles 16 to 18 of Directive 2008/57/EC and/or the declaration of conformity to type of a new vehicle referred to in Article 26 of Directive 2008/57/EC established in accordance with Decision 2008/232/EC or Decision 2011/291/EU shall be considered valid until the Member States decide that the type or design certificate needs to be renewed as stated in those Decisions.

Article 10

1. In order to keep pace with technological progress, innovative solutions may be required, which do not comply with the specifications set out in the Annex and/or for which the assessment methods set out in the Annex cannot be applied. In that case, new specifications and/or new assessment methods associated with those innovative solutions shall be developed.

⁽¹⁾ Directive 2004/49/EC of the European Parliament and of the Council of 29 April 2004 on safety on the Community's railways and amending Council Directive 95/18/EC on the licensing of railway undertakings and Directive 2001/14/EC on the allocation of railway infrastructure capacity and the levying of charges for the use of railway infrastructure and safety certification (OJ L 164, 30.4.2004, p. 44).

▼B

2. Innovative solutions may be related to the rolling stock subsystem, its parts and its interoperability constituents.
3. If an innovative solution is proposed, the manufacturer or his authorised representative established within the Union shall declare how it deviates from or complements to the relevant provisions of this TSI and submit the deviations to the Commission for analysis. The Commission may request the opinion of the European Railway Agency (the Agency) on the proposed innovative solution.
4. The Commission delivers an opinion on the innovative solution proposed. If this opinion is positive, the appropriate functional and interface specifications and the assessment method, which need to be included in the TSI in order to allow the use of this innovative solution, shall be developed and subsequently integrated in the TSI during the revision process pursuant to Article 6 of Directive 2008/57/EC. If the opinion is negative, the innovative solution proposed cannot be applied.
5. Pending the review of the TSI, the positive opinion delivered by the Commission shall be considered as acceptable means of compliance with the essential requirements of Directive 2008/57/EC and may therefore be used for the assessment of the subsystem.

Article 11

1. Decisions 2008/232/EC and 2011/291/EU are repealed with effect from 1 January 2015.

They shall however continue to apply to:

- (a) subsystems authorised in accordance with these Decisions;
 - (b) cases referred to in Article 9 of this Regulation;
 - (c) projects for new, renewed or upgraded subsystems which, at the date of publication of this Regulation, are at an advanced stage of development, are of an existing design or are the subject of a contract which is being carried out, as referred to in point 7.1.1.2 of the Annex to this Regulation.
2. Decision 2008/232/EC continues to apply for noise and crosswind requirements under the conditions set out in point 7.1.1.6 and 7.1.1.7 of the Annex to this Regulation.

Article 12

This Regulation shall enter into force on the twentieth day following that of its publication in the *Official Journal of the European Union*.

It shall apply from 1 January 2015. However, an authorisation for placing in service may be granted in accordance with the TSI as set out in the Annex to this Regulation, before 1 January 2015.

This Regulation shall be binding in its entirety and directly applicable in all Member States.

*ANNEX*

1. Introduction
 - 1.1. Technical Scope
 - 1.2. Geographical Scope
 - 1.3. Content of this TSI
2. Rolling stock subsystem and functions
 - 2.1. The rolling stock subsystem as part of the Union's rail system
 - 2.2. Definitions related to rolling stock
 - 2.2.1. Train formation
 - 2.2.2. Rolling stock
 - 2.3. Rolling stock in the scope of this TSI
 - 2.3.1. Types of rolling stock
 - 2.3.2. Track gauge
 - 2.3.3. Maximum speed
3. Essential requirements
 - 3.1. Elements of the rolling stock subsystem corresponding to the essential requirements
 - 3.2. Essential requirements not covered by this TSI
 - 3.2.1. General requirements, requirements related to maintenance and operation
 - 3.2.2. Requirements specific to other subsystems
4. Characterisation of the rolling stock subsystem
 - 4.1. Introduction
 - 4.1.1. General
 - 4.1.2. Description of the Rolling stock subject to the application of this TSI
 - 4.1.3. Main categorisation of the rolling stock for application of TSI requirements
 - 4.1.4. Categorisation of the rolling stock for fire safety
 - 4.2. Functional and technical specification of the sub-system
 - 4.2.1. General
 - 4.2.2. Structure and mechanical parts
 - 4.2.3. Track interaction and gauging
 - 4.2.4. Braking
 - 4.2.5. Passenger related items
 - 4.2.6. Environmental conditions and aerodynamic effects
 - 4.2.7. External lights & visible and audible warning devices
 - 4.2.8. Traction and electrical equipment
 - 4.2.9. Driver's Cab and driver-machine interface
 - 4.2.10. Fire safety and evacuation
 - 4.2.11. Servicing
 - 4.2.12. Documentation for operation and maintenance
 - 4.3. Functional and technical specification of the interfaces

▼B

- 4.3.1. Interface with Energy subsystem
- 4.3.2. Interface with Infrastructure subsystem
- 4.3.3. Interface with Operation subsystem
- 4.3.4. Interface with the Control, command and signalling subsystem
- 4.3.5. Interface with the Telematic application for passengers subsystem
- 4.4. Operating rules
- 4.5. Maintenance rules
- 4.6. Professional competencies
- 4.7. Health and safety conditions
- 4.8. European register of authorised types of vehicles
- 5. Interoperability constituents
 - 5.1. Definition
 - 5.2. Innovative solution
 - 5.3. Interoperability constituent specification
 - 5.3.1. Automatic centre buffer coupler
 - 5.3.2. Manual end coupling
 - 5.3.3. Rescue couplers
 - 5.3.4. Wheels
 - 5.3.5. WSP (wheel slide protection system)
 - 5.3.6. Head lamps
 - 5.3.7. Marker lamps
 - 5.3.8. Tail lamps
 - 5.3.9. Horns
 - 5.3.10. Pantograph
 - 5.3.11. Contact strips
 - 5.3.12. Main circuit breaker
 - 5.3.13. Driver's seat
 - 5.3.14. Toilet discharge connection
 - 5.3.15. Inlet connection for water tanks
- 6. Assessment of conformity or suitability for use and 'EC' verification
 - 6.1. Interoperability constituents
 - 6.1.1. Conformity assessment
 - 6.1.2. Application of modules
 - 6.1.3. Particular assessment procedures for interoperability constituents
 - 6.1.4. Project phases where assessment is required
 - 6.1.5. Innovative solutions
 - 6.1.6. Assessment of suitability for use
 - 6.2. Rolling stock subsystem
 - 6.2.1. EC verification (general)
 - 6.2.2. Application of modules

▼ B

- 6.2.3. Particular assessment procedures for subsystems
- 6.2.4. Project phases where assessment is required
- 6.2.5. Innovative solutions
- 6.2.6. Assessment of documentation requested for operation and maintenance
- 6.2.7. Assessment of units intended to be used in general operation
- 6.2.8. Assessment of units intended to be used in predefined formation(s)
- 6.2.9. Particular case: Assessment of units intended to be included in an existing fixed formation
- 6.3. Subsystem containing Interoperability constituents not holding an EC declaration
 - 6.3.1. Conditions
 - 6.3.2. Documentation
 - 6.3.3. Maintenance of the subsystems certified according to clause 6.3.1
- 7. Implementation
 - 7.1. General rules for implementation
 - 7.1.1. Application to newly built rolling stock
 - 7.1.2. Renewal and upgrade of existing rolling stock
 - 7.1.3. Rules related to the type or design examination certificates
 - 7.2. Compatibility with other subsystems
 - 7.3. Specific cases
 - 7.3.1. General
 - 7.3.2. List of specific cases
 - 7.4. Specific environmental conditions
 - 7.5. Aspects that have to be considered in the revision process or in other activities of the Agency
 - 7.5.1. Aspects related to a basic parameter in this TSI
 - 7.5.2. Aspects not related to a basic parameter in this TSI but subject to research projects
 - 7.5.3. Aspects relevant for the EU railway system but out of the scope of TSI's

▼ C1

- APPENDIX A — Buffers and screw coupling system
- APPENDIX B — 1 520 mm system gauge ‘T’
- APPENDIX C — Special provisions for on track machines (OTM)
- APPENDIX D — On-board energy measurement system
- APPENDIX E — Anthropometric measurements of the driver
- APPENDIX F — Front visibility
- APPENDIX G — Servicing
- APPENDIX H — Assessment of the rolling stock subsystem
- APPENDIX I — Aspects for which the technical specification is not available (open points)
- APPENDIX J — Technical specifications referred to in this TSI

▼ B

1. INTRODUCTION

1.1. **Technical Scope**

This technical specification for interoperability (TSI) is a specification by which a particular subsystem is addressed in order to meet the essential requirements and ensure the interoperability of the Union's rail system as described in Article 1 of Directive 2008/57/EC.

The particular subsystem is the rolling stock of the Union's rail system referred to in Annex II Section 2.7 of Directive 2008/57/EC.

This TSI is applicable to rolling stock:

— which is (or is intended to be) operated on the rail network defined in the Section 1.2 'Geographical scope' of this TSI,

and

— which is of one of the following types (as defined in Annex I Sections 1.2 and 2.2 of Directive 2008/57/EC):

- Self-propelling thermal or electric trains,
- Thermal or electric traction units,
- Passenger carriages,
- Mobile railway infrastructure construction and maintenance equipment.

Rolling stock of the types mentioned in Article 1(3) of Directive 2008/57/EC are excluded from the scope of this TSI:

- Metros, tram, and other light rail vehicles,
- Vehicles for the operation of local, urban or suburban passenger services on networks that are functionally separate from the rest of the railway system,
- Vehicles exclusively used on privately owned railway infrastructure that exists solely for use by the owner for its own freight operations,
- Vehicles reserved for a strictly local, historical or touristic use.

The detailed definition of the rolling stock in the scope of this TSI is given in Chapter 2.

1.2. **Geographical Scope**

The geographical scope of this TSI is the network of the whole rail system, composed of:

- The trans-European conventional rail system network (TEN) as described in Annex I Section 1.1 'Network' of Directive 2008/57/EC
- The trans-European high-speed rail system network (TEN) as described in Annex I Section 2.1 'Network' of Directive 2008/57/EC

▼B

- Other parts of the network of the whole rail system, following the extension of the scope as described in Annex I Section 4 of Directive 2008/57/EC,

and excludes the cases referred to in Article 1(3) of Directive 2008/57/EC.

1.3. **Content of this TSI**

In accordance with Article 5(3) of Directive 2008/57/EC this TSI:

- (a) indicates its intended scope (Chapter 2);
- (b) lays down essential requirements for the subsystem rolling stock 'Locomotives and passenger rolling stock' and its interfaces *vis-à-vis* other subsystems (Chapter 3);
- (c) establishes the functional and technical specifications to be met by the subsystem and its interfaces *vis-à-vis* other subsystems (Chapter 4);
- (d) determines the interoperability constituents and interfaces which must be covered by European specifications, including European standards, which are necessary to achieve interoperability within the European Union's rail system (Chapter 5);
- (e) states, in each case under consideration, which procedures are to be used in order to assess the conformity or the suitability for use of the interoperability constituents, on the one hand, or the 'EC' verification of the subsystems, on the other hand (Chapter 6);
- (f) indicates the strategy for implementing this TSI (Chapter 7);
- (g) indicates for the staff concerned, the professional qualifications and health and safety conditions at work required for the operation and maintenance of the subsystem, as well as for the implementation of this TSI (Chapter 4).

In accordance with Article 5(5) of Directive 2008/57/EC, provision may be made for specific cases for each TSI; such specific cases are indicated in Chapter 7.

2. **ROLLING STOCK SUBSYSTEM AND FUNCTIONS**

2.1. **The rolling stock subsystem as part of the Union's rail system**

The Union's rail system has been broken down into the following subsystems as defined in Annex II (Section 1) of Directive 2008/57/EC.

- (a) Structural areas:
 - Infrastructure,
 - Energy,
 - trackside control-command and signalling,
 - on-board control-command and signalling,
 - rolling stock;

▼ B

(b) Functional areas:

- Operation and traffic management,
- Maintenance,
- telematics applications for passenger and freight services.

With the exception of maintenance, each sub-system is dealt with in specific TSI(s).

The rolling stock subsystem dealt with in this TSI (as defined in Section 1.1) has interfaces with all other subsystems of the Union rail system mentioned above; these interfaces are considered within the frame of an integrated system, compliant with all the relevant TSIs.

Additionally, there are two TSIs describing specific aspects of the railway system and concerning several subsystems, the rolling stock subsystem being one of them:

- (a) safety in railway tunnels (TSI SRT);
- (b) accessibility for people with reduced mobility (TSI PRM);

and two TSIs concerning particular aspects of the rolling stock subsystem:

- (c) noise (TSI Noise);
- (d) freight wagons.

The requirements concerning the rolling stock subsystem expressed in these four TSIs are not repeated in the present TSI. These four TSIs apply also for the rolling stock subsystem according to their respective scopes and implementation rules.

2.2. **Definitions related to rolling stock**

For the purpose of this TSI, the following definitions apply:

2.2.1. *Train formation:*

- (a) A 'unit' is the generic term used to name the rolling stock which is subject to the application of this TSI, and therefore subject to 'EC' verification.
- (b) A Unit may be composed of several 'vehicles', as defined in Directive 2008/57/EC, Article 2(c); considering the scope of this TSI, the use of the term 'vehicle' in this TSI is limited to the rolling stock subsystem as defined in Chapter 1.
- (c) A 'train' is an operational formation consisting of one or more units.
- (d) A 'passenger train' is an operational formation accessible to passengers (a train composed of passenger vehicles but not accessible to passengers is not considered as a passenger train).
- (e) A 'fixed formation' is a train formation that can only be reconfigured within a workshop environment.

▼B

- (f) A ‘predefined formation(s)’ is a train formation(s) of several units coupled together, which is defined at design stage and can be reconfigured during operation.
- (g) ‘Multiple operation’: is an operational formation consisting of more than one unit:
- Trainsets designed so that several of them (of the type under assessment) are capable of being coupled together to operate as a single train controlled from 1 driver's cab.
 - Locomotives designed so that several of them (of the type under assessment) are capable of being included in a single train controlled from 1 driver's cab.
- (h) ‘General operation’: A unit is designed for general operation when the unit is intended to be coupled with other unit(s) in a train formation which **is not defined** at design stage.

2.2.2. *Rolling stock:*

Definitions below are classified in four groups as defined in the Section 1.2 of Annex I to Directive 2008/57/EC.

(A) Self-propelling thermal and/or electric trains:

- (a) A ‘trainset’ is a fixed formation that can operate as a train; it is by definition not intended to be reconfigured, except within a workshop environment. It is composed of only motored or of motored and non-motored vehicles.
- (b) An ‘electric and/or diesel multiple unit’ is a trainset in which all vehicles are capable of carrying a payload (passengers or luggage/mail or freight).
- (c) A ‘railcar’ is a vehicle that can operate autonomously and is capable of carrying a payload (passengers or luggage/mail or freight).

(B) Thermal and/or electric traction units:

A ‘locomotive’ is a traction vehicle (or combination of several vehicles) that is not intended to carry a payload and has the ability to be uncoupled in normal operation from a train and to operate independently.

A ‘shunter’ is a traction unit designed for use only on shunting yards, stations and depots.

Traction in a train can also be provided by a powered vehicle with or without driving cab, which is not intended to be uncoupled during normal operation. Such a vehicle is called a ‘power unit’ (or ‘power car’) in general or a ‘power head’ when located at one end of the trainset and fitted with a driving cab.

▼B**(C) Passenger carriages and other related cars:**

A 'coach' is a vehicle without traction in a fixed or variable formation capable of carrying passengers (by extension, requirements specified to apply to coaches in this TSI are deemed to apply also to restaurant cars, sleeping cars, couchettes cars, etc.).

A 'van' is a vehicle without traction capable of carrying payload other than passengers, e.g. luggage or mail, intended to be integrated into a fixed or variable formation which is intended to transport passengers.

A 'driving trailer' is a vehicle without traction equipped with a driving cab.

A coach may be equipped with a driver's cab; such a coach is then named a 'driving coach'.

A van may be fitted with a driver's cab and as such is known as a 'driving van'.

A 'car carrier' is a vehicle without traction capable of carrying passenger motor cars without their passengers and which is intended to be integrated in a passenger train.

A 'fixed rake of coaches' is a formation of several coaches 'semi-permanently' coupled together, or which can be reconfigured only when it is out of service.

(D) Mobile railway infrastructure construction and maintenance equipment

'On track machines (OTMs)' are vehicles specially designed for construction and maintenance of the track and infrastructure. OTMs are used in different modes: working mode, transport mode as self-propelling vehicle, transport mode as a hauled vehicle.

'Infrastructure inspection vehicles' are utilised to monitor the condition of the infrastructure. They are operated in the same way as freight or passenger trains, with no distinction between transport and working modes.

2.3. Rolling stock in the scope of this TSI**2.3.1. *Types of rolling stock***

The scope of this TSI concerning rolling stock, classified in four groups as defined in the Annex I Section 1.2 of Directive 2008/57/EC, is detailed as follows:

(A) Self-propelling thermal and/or electric trains:

This type includes any train in fixed or predefined formation, composed of vehicles passenger carrying and/or vehicles not carrying passengers.

Thermal or electric traction equipment is installed in some vehicles of the train, and the train is fitted with a driver's cab.

▼ B

Exclusion from the scope:

- Railcars or Electric and/or Diesel Multiple Units intended to operate on explicitly identified local, urban or suburban networks functionally separate from the rest of the railway system are not in the scope of this TSI.
- Rolling stock which is designed to operate primarily on urban metro, tramway or other light rail networks is not in the scope of this TSI.

These types of rolling stock may be authorised to operate on particular sections of the Union railway network that are identified for this purpose (due to the local configuration of the railway network) by reference to the Register of Infrastructure.

In that case, and provided that they are not explicitly excluded from the scope of Directive 2008/57/EC, Articles 24 and 25 of Directive 2008/57/EC (referring to national rules) are applicable.

(B) Thermal and/or electric traction units:

This type includes traction vehicles that are not capable of carrying a payload, such as thermal or electric locomotives or power units.

The concerned traction vehicles are intended for freight or/and passenger transport.

Exclusion from the scope:

Shunters (as defined in Section 2.2) are not in the scope of this TSI; when they are intended to operate on the Union railway network (movement between shunting yards, stations and depots), Articles 24 and 25 of Directive 2008/57/EC (referring to national rules) are applicable.

(C) Passenger carriages and other related cars:

- Passenger carriages:

This type includes vehicles without traction carrying passengers (coaches, as defined in Section 2.2), and operated in a variable formation with vehicles from the category 'thermal or electric traction units' defined above to provide the traction function.

- Non-passenger carrying vehicles included in a passenger train:

This type include vehicles without traction included in passenger trains (e.g. luggage or postal vans, car carriers, vehicles for service, etc.); they are in the scope of this TSI, as vehicles related to transport of passengers.

Exclusion from the scope of this TSI:

- Freight wagons are not in the scope of this TSI; they are covered by the 'freight wagons' TSI even when they are included in a passenger train (the train composition is in this case an operational issue).

▼B

- Vehicles intended to carry road motor vehicles (with persons on-board these road motor vehicles) are not in the scope of this TSI; when they are intended to operate on the Union railway network, Articles 24 and 25 of Directive 2008/57/EC (referring to national rules) are applicable.

(D) Mobile railway infrastructure construction and maintenance equipment

This type of rolling stock is in the scope of the TSI only when:

- It is running on its own rail wheels, and
- It is designed and intended to be detected by a track based train detection system for traffic management, and
- In case of OTMs, it is in transport (running) configuration, self-propelled or hauled.

Exclusion from the scope of this TSI:

In case of OTMs, working configuration is outside the scope of this TSI.

2.3.2. Track gauge

This TSI is applicable to rolling stock which is intended to be operated on networks of track gauge 1 435 mm, or on one of the following nominal track gauges: 1 520 mm, 1 524 mm system, 1 600 mm system and 1 668 mm system.

2.3.3. Maximum speed

Considering the integrated railway system composed of several subsystems (in particular fixed installations; see Section 2.1), the maximum design speed of rolling stock is deemed to be lower or equal to 350 km/h.

In case of maximum design speed higher than 350 km/h, this technical specification applies, but has to be complemented for the speed range above 350 km/h (or maximum speed related to a particular parameter, where specified in the relevant point of Section 4.2 up to the maximum design speed, by application of the procedure for innovative solutions described in Article 10.

3. ESSENTIAL REQUIREMENTS**3.1. Elements of the rolling stock subsystem corresponding to the essential requirements**

The following table indicates the essential requirements, as set out and numbered in Annex III of Directive 2008/57/EC, taken into account by the specifications set out in Chapter 4 of this TSI.

Rolling stock elements corresponding to essential requirements

Note: only points in Section 4.2 which contain requirements are listed.



Ref. Point	Element of the rolling stock sub-system	Safety	Reliability-Availability	Health	Environmental protection	Technical compatibility
4.2.2.2.2	Inner coupling	1.1.3 2.4.1				
4.2.2.2.3	End coupling	1.1.3 2.4.1				
4.2.2.2.4	Rescue coupling		2.4.2			2.5.3
4.2.2.2.5	Staff access for coupling and uncoupling	1.1.5		2.5.1		2.5.3
4.2.2.3	Gangways	1.1.5				
4.2.2.4	Strength of vehicle structure	1.1.3 2.4.1				
4.2.2.5	Passive safety	2.4.1				
4.2.2.6	Lifting and jacking					2.5.3
4.2.2.7	Fixing of devices to carbody structure	1.1.3				
4.2.2.8	Staff and freight access doors	1.1.5 2.4.1				
4.2.2.9	Mechanical characteristics of glass	2.4.1				
4.2.2.10	Load conditions and weighted mass	1.1.3				
4.2.3.1	Gauging					2.4.3
4.2.3.2.1	Axle load parameter					2.4.3
4.2.3.2.2	Wheel load	1.1.3				
4.2.3.3.1	Rolling stock characteristics for compatibility with train detection systems	1.1.1				2.4.3 2.3.2
4.2.3.3.2	Axle bearing condition monitoring	1.1.1	1.2			
4.2.3.4.1	Safety against derailment running on twisted track	1.1.1 1.1.2				2.4.3
4.2.3.4.2	Running dynamic behaviour	1.1.1 1.1.2				2.4.3
4.2.3.4.2.1	Limit values for running safety	1.1.1 1.1.2				2.4.3
4.2.3.4.2.2	Track loading limit values					2.4.3
4.2.3.4.3	Equivalent conicity	1.1.1 1.1.2				2.4.3

▼B

Ref. Point	Element of the rolling stock sub-system	Safety	Reliability-Availability	Health	Environmental protection	Technical compatibility
4.2.3.4.3.1	Design values for new wheel profiles	1.1.1 1.1.2				2.4.3
4.2.3.4.3.2	In-service values of wheelset equivalent conicity	1.1.2	1.2			2.4.3
4.2.3.5.1	Structural design of bogie frame	1.1.1 1.1.2				
4.2.3.5.2.1	Mechanical and geometrical characteristics of wheelsets	1.1.1 1.1.2				2.4.3
4.2.3.5.2.2	Mechanical and geometrical characteristics of wheels	1.1.1 1.1.2				
4.2.3.5.2.3	Variable gauge wheelsets	1.1.1 1.1.2				
4.2.3.6	Minimum curve radius	1.1.1 1.1.2				2.4.3
4.2.3.7	Life guards	1.1.1				
4.2.4.2.1	Braking — Functional requirements	1.1.1 2.4.1	2.4.2			1.5
4.2.4.2.2	Braking — Safety requirements	1.1.1	1.2 2.4.2			
4.2.4.3	Type of brake system					2.4.3
4.2.4.4.1	Emergency braking command	2.4.1				2.4.3
4.2.4.4.2	Service braking command					2.4.3
4.2.4.4.3	Direct braking command					2.4.3
4.2.4.4.4	Dynamic braking command	1.1.3				
4.2.4.4.5	Parking braking command					2.4.3
4.2.4.5.1	Braking performance — General requirements	1.1.1 2.4.1	2.4.2			1.5
4.2.4.5.2	Emergency braking	1.1.2 2.4.1				2.4.3
4.2.4.5.3	Service braking					2.4.3
4.2.4.5.4	Calculations related to thermal capacity	2.4.1				2.4.3
4.2.4.5.5	Parking brake	2.4.1				2.4.3
4.2.4.6.1	Limit of wheel rail adhesion profile	2.4.1	1.2 2.4.2			

▼ B

Ref. Point	Element of the rolling stock sub-system	Safety	Reliability-Availability	Health	Environmental protection	Technical compatibility
4.2.4.6.2	Wheel slide protection system	2.4.1	1.2 2.4.2			
4.2.4.7	Dynamic brake — Braking systems linked to traction system	2.4.1	1.2 2.4.2			
4.2.4.8.1.	Braking system independent of adhesion conditions — General	2.4.1	1.2 2.4.2			
4.2.4.8.2.	Magnetic track brake					2.4.3
4.2.4.8.3	Eddy current track brake					2.4.3
4.2.4.9	Brake state and fault indication	1.1.1	1.2 2.4.2			
4.2.4.10	Brake requirements for rescue purposes		2.4.2			
4.2.5.1	Sanitary systems				1.4.1	
4.2.5.2	Public address system: audible communication system	2.4.1				
4.2.5.3	Passenger alarm	2.4.1				
4.2.5.4	Communication devices for passengers	2.4.1				
4.2.5.5	Exterior doors: access to and egress from Rolling stock	2.4.1				
4.2.5.6	Exterior doors: system construction	1.1.3 2.4.1				
4.2.5.7	inter-unit doors	1.1.5				
4.2.5.8	Internal air quality			1.3.2		
4.2.5.9	body side windows	1.1.5				
4.2.6.1	Environmental conditions		2.4.2			
4.2.6.2.1	Slipstream effects on passengers on platform and on workers at track side	1.1.1		1.3.1		
4.2.6.2.2	Head pressure pulse					2.4.3
4.2.6.2.3	Maximum pressure variations in tunnels					2.4.3

▼B

Ref. Point	Element of the rolling stock sub-system	Safety	Reliability-Availability	Health	Environmental protection	Technical compatibility
4.2.6.2.4	Cross wind	1.1.1				
4.2.6.2.5	Aerodynamic effect on ballasted track	1.1.1				2.4.3
4.2.7.1.1	Head lights					2.4.3
4.2.7.1.2	Marker lights	1.1.1				2.4.3
4.2.7.1.3	Tail lights	1.1.1				2.4.3
4.2.7.1.4	Lamp controls					2.4.3
4.2.7.2.1	Horn — General	1.1.1				2.4.3 2.6.3
4.2.7.2.2	Warning horn sound pressure levels	1.1.1		1.3.1		
4.2.7.2.3	Protection					2.4.3
4.2.7.2.4	Horn control	1.1.1				2.4.3
4.2.8.1	Traction performance					2.4.3 2.6.3
4.2.8.2 4.2.8.2.1 to 4.2.8.2.9-	Power supply					1.5 2.4.3 2.2.3
4.2.8.2.10	Electrical protection of the train	2.4.1				
4.2.8.3	Diesel and other thermal traction system	2.4.1				1.4.1
4.2.8.4	Protection against electrical hazards	2.4.1				
4.2.9.1.1	Driver's cab — General	—	—	—	—	—
4.2.9.1.2	Access and egress	1.1.5				2.4.3
4.2.9.1.3	External visibility	1.1.1				2.4.3
4.2.9.1.4	Interior layout	1.1.5				
4.2.9.1.5	Driver's seat			1.3.1		
4.2.9.1.6	Driver's desk- Ergonomics	1.1.5		1.3.1		
4.2.9.1.7	Climate control and air quality			1.3.1		
4.2.9.1.8	Internal lighting					2.6.3

▼B

Ref. Point	Element of the rolling stock sub-system	Safety	Reliability-Availability	Health	Environmental protection	Technical compatibility
4.2.9.2.1	Windscreen — Mechanical characteristics	2.4.1				
4.2.9.2.2	Windscreen — Optical characteristics					2.4.3
4.2.9.2.3	Windscreen — Equipment					2.4.3
4.2.9.3.1	Driver's activity control function	1.1.1				2.6.3
4.2.9.3.2	Speed indication	1.1.5				
4.2.9.3.3	Driver display unit and screens	1.1.5				
4.2.9.3.4	Controls and indicators	1.1.5				
4.2.9.3.5	Labelling					2.6.3
4.2.9.3.6	Radio remote control function by staff for shunting operation	1.1.1				
4.2.9.4	On-board tools and portable equipment	2.4.1				2.4.3 2.6.3
4.2.9.5	Storage facility for staff personal effects	—	—	—	—	—
4.2.9.6	Recording device					2.4.4
4.2.10.2	Fire safety — Measures to prevent fire	1.1.4		1.3.2	1.4.2	
4.2.10.3	Measures to detect/control fire	1.1.4				
4.2.10.4	Requirements related to emergency situations	2.4.1				
4.2.10.5	Requirements related to evacuation	2.4.1				
4.2.11.2	Train exterior cleaning					1.5
4.2.11.3	Connection to toilet discharge system					1.5
4.2.11.4	Water refilling equipment			1.3.1		
4.2.11.5	Interface for water refilling					1.5
4.2.11.6	Special requirements for stabling of trains					1.5
4.2.11.7	Refuelling equipment					1.5

▼ B

Ref. Point	Element of the rolling stock sub-system	Safety	Reliability-Availability	Health	Environmental protection	Technical compatibility
4.2.11.8	Train interior cleaning — power supply					2.5.3
4.2.12.2	General documentation					1.5
4.2.12.3	Documentation related to maintenance	1.1.1				2.5.1 2.5.2 2.6.1 2.6.2
4.2.12.4	Operating documentation	1.1.1				2.4.2 2.6.1 2.6.2
4.2.12.5	Lifting diagram and instructions					2.5.3
4.2.12.6	Rescue related descriptions		2.4.2			2.5.3

3.2. **Essential requirements not covered by this TSI**

Some of the essential requirements classified as ‘general requirements’ or ‘specific to other subsystems’ in Annex III to Directive 2008/57/EC have an impact on the rolling stock subsystem; those that are not covered, or are covered with limitations within the scope of this TSI, are identified below

3.2.1. *General requirements, requirements related to maintenance and operation*

The numbering of the paragraphs and the essential requirements hereunder are those set out in Annex III to Directive 2008/57/EC.

The essential requirements that are not covered within the scope of this TSI are the following:

1.4. **Environmental protection**

1.4.1. *‘The environmental impact of establishment and operation of the rail system must be assessed and taken into account at the design stage of the system in accordance with the Community provisions in force.’*

This essential requirement is covered by the relevant European provisions in force.

1.4.3. *‘The rolling stock and energy-supply systems must be designed and manufactured in such a way as to be electromagnetically compatible with the installations, equipment and public or private networks with which they might interfere.’*

This essential requirement is covered by the relevant European provisions in force.

1.4.4. *‘Operation of the rail system must respect existing regulations on noise pollution.’*

This essential requirement is covered by the relevant European provisions in force (in particular Noise TSI, and HS RST TSI 2008 until all rolling stock are covered by the Noise TSI).

▼ B

- 1.4.5. *‘Operation of the rail system must not give rise to an inadmissible level of ground vibrations for the activities and areas close to the infrastructure and in a normal state of maintenance.’*

This essential requirement is in the scope of the Infrastructure.

2.5 Maintenance

These essential requirements are relevant within the scope of this TSI according to Section 3.1 of this TSI only for the technical maintenance documentation related to the rolling stock subsystem; they are not covered within the scope of this TSI regarding maintenance installations.

2.6 Operation

These essential requirements are relevant within the scope of this TSI according to Section 3.1 of this TSI for the operating documentation related to the rolling stock subsystem (essential requirements 2.6.1 and 2.6.2), and for technical compatibility of the rolling stock with operating rules (essential requirements 2.6.3).

3.2.2. *Requirements specific to other subsystems*

Requirements on the relevant other sub-systems are necessary to fulfil these essential requirements for the whole railway system.

The requirements on the rolling stock subsystem which contribute to the fulfilment of these essential requirements are mentioned in the Section 3.1 of this TSI; corresponding essential requirements are those set out in Sections 2.2.3 and 2.3.2 of Annex III to Directive 2008/57/EC.

Other essential requirements are not covered within the scope of this TSI.

4. CHARACTERISATION OF THE ROLLING STOCK SUBSYSTEM

4.1. Introduction

4.1.1. General

- (1) The Union's rail system, to which Directive 2008/57/EC applies and of which the rolling stock subsystem is a part, is an integrated system whose consistency needs to be verified. This consistency must be checked in particular with regard to the specifications of the rolling stock subsystem, its interfaces with the other subsystems of the Union's rail system in which it is integrated, as well as the operating and maintenance rules.
- (2) The basic parameters of the rolling stock sub-system are defined in the present Chapter 4 of this TSI.
- (3) Except where this is strictly necessary for the interoperability of the Union's rail system, the functional and technical specifications of the subsystem and its interfaces described in Sections 4.2 and 4.3, do not impose the use of specific technologies or technical solutions.

▼B

- (4) Some of the rolling stock characteristics that are mandated to be recorded in the 'European register of authorised types of vehicles' (according to the relevant Commission Decision) are described in Sections 4.2 and 6.2 of this TSI. Additionally, these characteristics are required to be provided in the rolling stock technical documentation described in point 4.2.12 of this TSI.

4.1.2. *Description of the Rolling stock subject to the application of this TSI*

- (1) Rolling stock subject to the application of this TSI (designated as a unit in the context of this TSI) shall be described in the certificate of 'EC' verification, using one of the following characteristics:

- Trainset in fixed formation and, when required, predefined formation(s) of several trainsets of the type under assessment for multiple operation.
- Single vehicle or fixed rakes of vehicles intended for predefined formation(s).
- Single vehicle or fixed rakes of vehicles intended for general operation and when required, predefined formation(s) of several vehicles (locomotives) of the type under assessment for multiple operation.

Note: Multiple operation of the unit under assessment with other types of rolling stock is not in the scope of this TSI.

- (2) Definitions related to train formation and units are given in Section 2.2 of this TSI.
- (3) When a unit intended for use in fixed or predefined formation(s) is assessed, the formation(s) for which such assessment is valid shall be defined by the party asking for assessment, and stated in the certificate of 'EC' verification. The definition of each formation shall include the type designation of each vehicle (or of vehicle bodies and wheelsets in case of articulated fixed formation), and their arrangement in the formation. Additional details are given in clauses 6.2.8 and 9.
- (4) Some characteristics or some assessments of a unit intended to be used in general operation, will require defined limits regarding the train formations. These limits are laid down in Section 4.2 and in clause 6.2.7.

4.1.3. *Main categorisation of the rolling stock for application of TSI requirements*

- (1) A rolling stock technical categorisation system is used in the following clauses of this TSI to define relevant requirements applicable to a unit.
- (2) The technical category(ies) relevant for the unit subject to the application of this TSI shall be identified by the party asking for assessment. This categorisation shall be used by the notified body in charge of the assessment, in order to assess the applicable requirements from this TSI, and shall be stated in the certificate of 'EC' verification.

▼B

- (3) The technical categories of rolling stock are the following:
- Unit designed to carry passengers
 - Unit designed to carry passenger-related load (luggage, cars, etc.)
 - Unit designed to carry other payload (mail, freight, etc.) in self-propelling trains
 - Unit fitted with a driver's cab
 - Unit fitted with traction equipment
 - Electric unit, defined as a unit supplied with electric energy by electrification system(s) specified in the Energy TSI.
 - Thermal traction unit
 - Freight locomotive: Unit designed to haul freight wagons
 - Passenger locomotive: Unit designed to haul passenger carriages
 - OTMs
 - Infrastructure inspection vehicles.
- A unit is characterised by one or several of the categories above.
- (4) Unless stated otherwise in the clauses of Section 4.2, requirements specified in this TSI apply to all technical categories of rolling stock defined above.
- (5) The unit operational configuration shall also be considered when it is assessed; a distinction shall be made between:
- A unit that can be operated as a train.
 - A unit that cannot be operated alone, and that has to be coupled with other unit(s) to be operated as a train (see also clauses 4.1.2, 6.2.7 and 6.2.8).
- (6) The maximum design speed of the unit subject to the application of this TSI shall be declared by the party asking for assessment; it shall be a multiple of 5 km/h (see also clause 4.2.8.1.2) when its value is higher than 60 km/h; it shall be used by the notified body in charge of the assessment, in order to assess the applicable requirements from this TSI, and shall be stated in the certificate of 'EC' verification.

4.1.4. *Categorisation of the rolling stock for fire safety*

- (1) In respect of fire safety requirements, four categories of rolling stock are defined and specified in the TSI SRT.
- Category A passenger rolling stock (including passenger locomotive),
 - Category B passenger rolling stock (including passenger locomotive),

▼ B

- Freight locomotive, and self-propelling unit designed to carry other payload than passengers (mail, freight, infrastructure inspection vehicle, etc.),
 - OTMs.
- (2) The compatibility between the category of the unit and its operation in tunnels is set out in the TSI SRT.
 - (3) For units designed to carry passengers or haul passenger carriages, and subject to the application of this TSI, category A is the minimum category to be selected by the party asking for assessment; the criteria for selecting category B are given in the TSI SRT.
 - (4) This categorisation shall be used by the notified body in charge of the assessment, in order to assess the applicable requirements from the clause 4.2.10 of this TSI, and shall be stated in the certificate of 'EC' verification.

4.2. Functional and technical specification of the sub-system**4.2.1. General****4.2.1.1. Breakdown**

- (1) The functional and technical specifications of the rolling stock subsystem are grouped and sorted out in the following clauses of this section:
 - Structures and mechanical parts
 - Track interaction and gauging
 - Braking
 - Passenger related items
 - Environmental conditions
 - External lights & audible and visible warning devices
 - Traction and electrical equipment
 - Driver's cab and driver-machine interface
 - Fire safety and evacuation
 - Servicing
 - Documentation for operation and maintenance
- (2) For particular technical aspects specified in Chapters 4, 5 and 6, the functional and technical specification makes an explicit reference to a clause of an EN standard or other technical document, as allowed by Article 5(8) of Directive 2008/57/EC; these references are listed in the Appendix J of this TSI.
- (3) Information needed on board for the train staff to be aware of the operational state of the train (normal state, equipment out of order, degraded situation ...) are described in the clause dealing with the relevant function, and in clause 4.2.12 'documentation for the operation and maintenance'.

▼B

4.2.1.2. Open points

- (1) When, for a particular technical aspect, the functional and technical specification necessary to meet the essential requirements has not been yet developed, and therefore is not included in this TSI, this aspect is identified as an open point in the relevant clause; Appendix I of this TSI lists all open points, as required in Article 5(6) of Directive 2008/57/EC.

The Appendix I mentions also if the open points relate to technical compatibility with the network; for this purpose, the Appendix I is split in 2 parts:

— Open points that relate to technical compatibility between the vehicle and the network.

— Open points that do not relate to technical compatibility between the vehicle and the network.

- (2) As required in Articles 5(6) and 17(3) of Directive 2008/57/EC, open points shall be addressed by the application of national technical rules.

4.2.1.3. Safety aspects

- (1) The functions that are essential to safety are identified in Section 3.1 of this TSI by their link to the essential requirements 'safety'.
- (2) Safety requirements related to these functions are covered by the technical specifications expressed in the corresponding clause of Section 4.2 (e.g. 'passive safety', 'wheels', etc.).
- (3) Where these technical specifications need to be complemented by requirements expressed in terms of safety requirements (severity level), they are also specified in the corresponding clause of Section 4.2.
- (4) Electronic devices and software, which are used to fulfil functions essential to safety shall be developed and assessed according to a methodology adequate for safety related electronic devices and software.

4.2.2. *Structure and mechanical parts*

4.2.2.1. General

- (1) This part addresses requirements relating to the design of vehicle structural body (strength of vehicle structure) and of the mechanical links (mechanical interfaces) between vehicles or between units.
- (2) Most of these requirements aim at ensuring the train's mechanical integrity in operation and rescue operation as well as protecting passenger and staff compartments in the event of collision or derailment.

4.2.2.2. Mechanical interfaces

4.2.2.2.1. General and definitions

In order to form a train (as defined in Section 2.2) vehicles are coupled together in a way that enables them to be operated together. The coupling is the mechanical interface that enables this. There are several types of couplings:

▼B

- (1) 'Inner' coupling (also called 'intermediate' coupling) is the coupling device between vehicles in order to form a unit composed of several vehicles (e.g. a fixed rake of coaches or a trainset)
- (2) 'End coupling' ('external' coupling) of units is the coupling device used to couple together two (or several) units to form a train. An end coupling can be 'automatic', 'semi-automatic' or 'manual'. An end coupling can be used for rescue purpose (see clause 4.2.2.2.4). In the context of this TSI, a 'Manual' coupling is an end coupling system which requires (one or several) person(s) to stand between the units to be coupled or uncoupled for the mechanical coupling of these units.
- (3) 'Rescue coupling' is the coupling device that enables a unit to be rescued by a recovery power unit equipped with a 'standard' manual coupling as per clause 4.2.2.2.3 where the unit to be rescued is equipped with a different coupling system or is not equipped with any coupling system.

4.2.2.2.2 Inner coupling

- (1) Inner couplings between the different vehicles (fully supported by their own wheels) of a unit shall incorporate a system capable of withstanding the forces due to the intended operating conditions.
- (2) Where the inner coupling system between vehicles has a lower longitudinal strength than the end coupling(s) of the unit, provisions shall be made to rescue the unit in case of breakage of any such inner coupling; these provisions shall be described in the documentation required in clause 4.2.12.6.
- (3) In case of articulated units, the joint between two vehicles sharing the same running gear shall comply with the requirements of the specification referenced in Appendix J-1, index 1.

4.2.2.2.3 End coupling

(a) General Requirements

(a-1) Requirements on characteristics of end coupling

- (1) Where an end coupling is provided at any end of a unit, the following requirements apply to all types of end coupling (automatic, semi-automatic or manual):
 - End couplings shall incorporate a resilient coupling system, capable of withstanding the forces due to the intended operational and rescue conditions.
 - The type of mechanical end coupling together with its nominal maximum design values of tensile and compressive forces and the height above rail level of its centre line (unit in working order with new wheels) shall be recorded in the technical documentation described in clause 4.2.12.

▼B

- (2) Where there is no coupling at any end of a unit, a device to allow a rescue coupling shall be provided at such end of the unit.

(a-2) Requirements on type of end coupling

- (1) Units assessed in fixed or predefined formation, and of maximum design speed higher or equal to 250 km/h, shall be equipped at each end of the formation with an automatic centre buffer coupler geometrically and functionally compatible with a 'Type 10 latch system automatic centre buffer coupler' (as defined in clause 5.3.1); the height above rail of its coupling centre line shall be 1 025 mm + 15 mm /- 5 mm (measured with new wheels in load condition 'design mass in working order').
- (2) Units designed and assessed for general operation and designed to be operated solely on the 1 520 mm system shall be fitted with a centre buffer coupler geometrically and functionally compatible with a 'SA3 coupling'; the height above rail of its coupling centre line shall be between 980 to 1 080 mm (for all wheel and load conditions).

(b) Requirements on 'Manual' coupling system

(b-1) Provisions to units

- (1) The following provisions apply specifically to units fitted with a 'Manual' coupling system:
- The coupling system shall be designed so that no human presence between the units to be coupled/uncoupled is required whilst either one is moving.
 - For units designed and assessed to be operated in 'general operation' or in 'predefined formation', and fitted with a manual coupling system, this coupling system shall be of UIC type (as defined in clause 5.3.2).
- (2) These units shall comply with the additional requirements of point (b-2) below.

(b-2) Compatibility between units

On units equipped with manual coupling system of UIC type (as described in clause 5.3.2) and pneumatic brake system compatible with UIC type (as described in clause 4.2.4.3), the following requirements apply:

- (1) The buffers and the screw coupling shall be installed according to clauses A.1 to A.3 of Appendix A.

▼B

- (2) The dimensions and layout of brake pipes and hoses, couplings and cocks shall meet the following requirements:
- The interface of the brake pipe and main reservoir pipe shall be as set out in the specification referenced in Appendix J-1, index 2.
 - The opening of the automatic air brake coupling head shall face the left when looking at the end of the vehicle.
 - The opening of the main reservoir coupling head shall face the right when looking at the end of the unit.
 - The end cocks shall be in accordance with the specification referenced in Appendix J-1, index 3.
 - The lateral location of brake pipes and cocks shall be compatible with the requirements of the specification referenced in Appendix J-1, index 4.

4.2.2.2.4 Rescue coupling

- (1) Provisions shall be made to enable the recovery of the line in case of breakdown by hauling or propelling the unit to be rescued.
- (2) Where the unit to be rescued is fitted with an end coupling, rescue shall be possible by means of a power unit equipped with the same type of end coupling system (including compatible height above rail level of its centre line).
- (3) For all units, rescue shall be possible by means of a recovery unit i.e. a power unit featuring at each of its ends intended to be used for rescue purposes:
- (a) On 1 435 mm, 1 524 mm, 1 600 mm or 1 668 mm systems:
- A manual coupling system of UIC type (as described in clauses 4.2.2.2.3 and 5.3.2) and pneumatic brake system of UIC type (as described in clause 4.2.4.3),
 - Lateral location of brake pipes and cocks according to the specification referenced in Appendix J-1, index 5,
 - A free space of 395 mm above the centre line of the hook to allow the fitting of the rescue adaptor as described below.
- (b) On 1 520 mm system:
- A centre buffer coupler geometrically and functionally compatible with a 'SA3 coupling'; the height above rail of its coupling centre line being between 980 to 1 080 mm (for all wheel and load conditions).

▼B

This is achieved either by means of a permanently installed compatible coupling system or through a rescue coupler (also called rescue adaptor). In the latter case, the unit assessed against this TSI shall be designed so that it is possible to carry the rescue coupler on-board.

- (4) The rescue coupler (as defined in clause 5.3.3) shall comply with the following requirements:
- To be designed to allow the rescue at a speed of at least 30 km/h,
 - To be secured after mounting onto the recovery unit in a way that prevents it coming off during the rescue operation,
 - To withstand the forces due to the intended rescuing conditions,
 - To be designed such that it does not require any human presence between the recovery unit and the unit to be rescued whilst either one is moving,
 - Neither the rescue coupler nor any braking hose shall limit the lateral movement of the hook when fitted onto the recovery unit.
- (5) The brake requirement for rescue purpose is covered by the clause 4.2.4.10 of this TSI.

4.2.2.2.5 Staff access for coupling and uncoupling

- (1) Units and end coupling-systems shall be designed so that staff is not exposed to undue risk during coupling and uncoupling, or rescue operations.
- (2) To comply with this requirement, units fitted with manual coupling systems of UIC type as per clause 4.2.2.3(b) shall comply with the following requirements (the 'Bern rectangle'):
- On units equipped with screw couplers and side buffers, the space for staff operation shall be in accordance to the specification referenced in Appendix J-1, index 6.
 - Where a combined automatic and screw coupler is fitted it is permissible for the auto coupler head to infringe the Bern rectangle on the left hand side when it is stowed and the screw coupler is in use.
 - There shall be a handrail under each buffer. The handrails shall withstand a force of 1,5 kN.
- (3) The operating and rescue documentation specified in clauses 4.2.12.4 and 4.2.12.6 shall describe measures that are necessary to meet this requirement. Member States may also require application of those requirements.

4.2.2.3. Gangways

- (1) Where a gangway is provided as a means for passengers to circulate from one coach or one trainset to another, it shall accommodate all relative movements of vehicles in normal operation without exposing passengers to undue risk.

▼ B

- (2) Where operation with the gangway not being connected is foreseen, it shall be possible to prevent access by passengers to the gangway.
- (3) Requirements related to the gangway door when the gangway is not in use are specified in clause 4.2.5.7 'Passenger-related items — Inter-unit doors'.
- (4) Additional requirements are expressed in the TSI PRM.
- (5) These requirements of this clause do not apply to the end of vehicles where this area is not intended for regular use by passengers.

4.2.2.4. Strength of vehicle structure

- (1) This clause applies to all units except OTMs.
- (2) For OTMs, alternative requirements to those expressed in this clause for static load, category and acceleration are set out in Appendix C, clause C.1.
- (3) The static and dynamic strength (fatigue) of vehicle bodies is relevant to ensure the safety required for the occupants and the structural integrity of the vehicles in train and in shunting operations. Therefore, the structure of each vehicle shall comply with the requirements of the specification referenced in Appendix J-1, index 7. The rolling stock categories to be taken into account shall correspond to category L for locomotives and power head units and categories PI or PII for all other types of vehicle within the scope of this TSI, as defined in the specification referenced in Appendix J-1, index 7, clause 5.2.
- (4) Proof of the strength of the vehicle body may be demonstrated by calculations and/or by testing, according to the conditions set up in the specification referenced in Appendix J-1, index 7, clause 9.2.
- (5) In case of a unit designed for higher compressive force than those of the categories (required above as a minimum) in the specification referenced in Appendix J-1, index 7, this specification does not cover the proposed technical solution; it is then permissible to use for compressive force other normative documents that are publicly available.

In that case it shall be verified by the notified body that the alternative normative documents form part of a technically consistent set of rules applicable to the design, construction and testing of the vehicle structure.

The value of compressive force shall be recorded in the technical documentation defined in clause 4.2.12.

- (6) The load conditions considered shall be consistent with those defined in clause 4.2.2.10 of this TSI.
- (7) The assumptions for aerodynamic loading shall be those described in clause 4.2.6.2.2 of this TSI (passing of 2 trains).
- (8) Joining techniques are covered by the above requirements. A verification procedure shall exist to ensure at the production phase that defects that may decrease the mechanical characteristics of the structure are controlled.

▼B4.2.2.5. *Passive safety*

- (1) The requirements specified in this clause apply to all units, except to units not intended to carry passengers or staff during operation and except to OTMs.
- (2) For units designed to be operated on the 1 520 mm system, the requirements on passive safety described in this clause are of voluntary application. If the Applicant chooses to apply the requirements on passive safety described in this clause, this shall be recognised by Member States. Member States may also require application of those requirements.
- (3) For locomotives designed to be operated on the 1 524 mm system, the requirements on passive safety described in this clause are of voluntary application. If the Applicant chooses to apply the requirements on passive safety described in this clause, this shall be recognised by Member States.
- (4) Units which cannot operate up to the collision speeds specified under any of the collision scenarios below are exempted from the provisions related to that collision scenario.
- (5) Passive safety is aimed at complementing active safety when all other measures have failed. For this purpose, the mechanical structure of vehicles shall provide protection of the occupants in the event of a collision by providing means of:

- limiting deceleration
- maintaining survival space and structural integrity of the occupied areas
- reducing the risk of overriding
- reducing the risk of derailment
- limiting the consequences of hitting a track obstruction.

To meet these functional requirements, units shall comply with the detailed requirements specified in the specification referenced in Appendix J-1, index 8 related to crashworthiness design category C-I (as per the specification referenced in Appendix J-1, index 8, Table 1 Section 4), unless specified otherwise below.

The following four reference collision scenarios shall be considered:

- scenario 1: A front end impact between two identical units,
- scenario 2: A front end impact with a freight wagon,
- scenario 3: An impact of the unit with a large road vehicle on a level crossing,
- scenario 4: An impact of the unit into a low obstacle (e.g. car on a level crossing, animal, rock, etc.)

These scenarios are described in the specification referenced in Appendix J-1, index 8, Table 2 of Section 5.

▼B

- (6) Within the scope of the present TSI, 'Table 2 application rules' in the specification referenced in point (5) above are completed by the following: the application of requirements related to scenarios 1 and 2 to locomotives:

- fitted with automatic end centre buffer couplers,
- and capable of a traction effort higher than 300 kN

is an open point.

Note: such high traction effort is required for heavy haul freight locomotives.

- (7) Due to their specific architecture, it is permitted for locomotives with single 'central cab' as an alternative method to demonstrate compliance against the requirement of scenario 3 by demonstrating compliance with following criteria:

- the frame of the locomotive is designed according to the specification referenced in Appendix J-1, index 8 cat L (as already specified in clause 4.2.2.4 of this TSI),
- the distance between buffers and windscreen cab is at least 2,5 m.

- (8) The present TSI specifies crashworthiness requirements applicable within its scope; therefore, the Annex A of the specification referenced in Appendix J-1, index 8 shall not apply. The requirements of the specification referenced in Appendix J-1, index 8 Section 6 shall be applied in relation to the above given reference collision scenarios.

- (9) To limit the consequences of hitting a track obstruction, the leading ends of locomotives, power heads, driving coaches and trainsets shall be equipped with an obstacle deflector. The requirements with which obstacle deflectors shall comply are defined in the specification referenced in Appendix J-1, index 8, Table 3 of Section 5 and Section 6.5.

4.2.2.6. Lifting and jacking

- (1) This clause applies to all units.
- (2) Additional provisions concerning the lifting and jacking of OTMs are specified in Appendix C, clause C.2.
- (3) It shall be possible to safely lift or jack each vehicle composing the unit, for recovery purposes (following derailment or other accident or incident), and for maintenance purposes. To this purpose, suitable vehicle body interfaces (lifting/jacking points) shall be provided, which permit the application of vertical or quasi-vertical forces. The vehicle shall be designed for complete lifting or jacking, including the running gear (e.g. by securing/attaching the bogies to the vehicle body). It shall also be possible to lift or jack any end of the vehicle (including its running gear) with the other end resting on the remaining running gear(s).

▼ B

- (4) It is recommended to design jacking points so that they can be used as lifting points with all the running gears of the vehicle linked to the underframe of the vehicle.
- (5) Jacking/Lifting points shall be located such as to enable the safe and stable lifting of the vehicle; sufficient space shall be provided underneath and around each jacking point to allow an easy installation of rescue devices. Jacking/Lifting points shall be designed such that staff is not exposed to any undue risk under normal operation or when using the rescue equipment.
- (6) When the lower structure of the bodyshell does not allow the provision of permanent built-in jacking/lifting points, this structure shall be provided with fixtures which permit the fixation of removable jacking/lifting points during the re-railing operation.
- (7) The geometry of permanent built-in jacking/lifting points shall be compliant with the specification referenced in Appendix J-1, index 9, clause 5.3; the geometry of removable jacking/lifting points shall be compliant with the specification referenced in Appendix J-1, index 9, clause 5.4.
- (8) Marking of lifting points shall be made by signs compliant with the specification referenced in Appendix J-1, index 10.
- (9) The structure shall be designed with consideration of the loads specified in the specification referenced in Appendix J-1, index 11, clauses 6.3.2 and 6.3.3; proof of the strength of the vehicle body may be demonstrated by calculations or by testing, according to the conditions set up in the specification referenced in Appendix J-1, index 11, clause 9.2.

Alternative normative documents may be used under the same conditions as defined in clause 4.2.2.4 above.

- (10) For each vehicle of the unit, a jacking and lifting diagram and corresponding instructions shall be provided in the documentation as described in clauses 4.2.12.5 and 4.2.12.6 of this TSI. Instructions shall be given as far as feasible by pictograms.

4.2.2.7. Fixing of devices to carbody structure

- (1) This clause applies to all units, except to OTMs.
- (2) Provisions concerning the structural strength of OTMs are specified in Appendix C, clause C.1.
- (3) Fixed devices including those inside the passenger areas, shall be attached to the car body structure in a way that prevents these fixed devices becoming loose and presenting a risk of passenger injuries or lead to a derailment. To this

▼B

aim, attachments of these devices shall be designed according to the specification referenced in Appendix J-1, index 12, considering category L for locomotives and category P-I or P-II for passenger rolling stock.

Alternative normative documents may be used under the same conditions as defined in clause 4.2.2.4 above.

4.2.2.8. Staff and freight Access doors

- (1) The doors for use of passengers are covered by the clause 4.2.5 of this TSI: 'Passenger related items'. Cab doors are addressed in clause 4.2.9 of this TSI. This clause addresses doors for freight use and for use of train crew other than cab doors.
- (2) Vehicles fitted with a compartment dedicated to train crew or freight shall be equipped with a device to close and lock the doors. The doors shall remain closed and locked until they are intentionally released.

4.2.2.9. Mechanical characteristics of glass (other than windscreens)

- (1) Where glass is used in glazing (including mirrors), it shall be either laminated or toughened glass which is in accordance with one of the relevant publicly available standards suitable for railway application with regard to the quality and area of use, thereby minimising the risk to passenger and staff being injured by breaking glass.

4.2.2.10. Load conditions and weighed mass

- (1) The following load conditions defined in the specification referenced in Appendix J-1, index 13, clause 2.1 shall be determined:

— Design mass under exceptional payload

— Design mass under normal payload

— Design mass in working order

- (2) The hypothesis taken for arriving at the load conditions above shall be justified and documented in the general documentation described in clause 4.2.12.2 of this TSI.

These hypothesis shall be based on a rolling stock categorisation (high speed and long distance train, other) and on a payload description (passengers, payload per m² in standing and service areas) consistent with the specification referenced in Appendix J-1, index 13; values for the different parameters may deviate from this standard provided that they are justified.

- (3) For OTMs, different load conditions (minimum mass, maximum mass) may be used, in order to take into account optional on-board equipment.
- (4) The conformity assessment procedure is described in clause 6.2.3.1 of this TSI.
- (5) For each load condition defined above, the following information shall be provided in the technical documentation described in clause 4.2.12:

— Total vehicle mass (for each vehicle of the unit)

▼ B

— Mass per axle (for each axle)

— Mass per wheel (for each wheel).

Note: for units equipped with independently rotating wheels, ‘axle’ shall be interpreted as a geometric notion, and not as a physical component; this is valid to the whole TSI, unless stated otherwise.

4.2.3. *Track interaction and gauging*

4.2.3.1. *Gauging*

- (1) This clause concerns the rules for calculation and verification intended for sizing the rolling stock to run on one or several infrastructures without interference risk.

For units designed to be operated on other track gauge(s) than 1 520 mm system:

- (2) The applicant shall select the intended reference profile including the reference profile for the lower parts. This reference profile shall be recorded in the technical documentation defined in clause 4.2.12 of this TSI.
- (3) The compliance of a unit with this intended reference profile shall be established by one of the methods set out in the specification referenced in Appendix J-1, index 14.

During a transitional period ending 3 years after the date of application of this TSI, for technical compatibility with the existing national network it is permissible for the reference profile of the unit to alternatively be established in accordance with the national technical rules notified for this purpose.

This shall not prevent the access of TSI compliant rolling stock to the national network.

- (4) In case the unit is declared as compliant with one or several of the reference contours G1, GA, GB, GC or DE3, including those related to the lower part G11, G12 or G13, as set out in the specification referenced in Appendix J-1, index 14, compliance shall be established by the kinematic method as set out in the specification referenced in Appendix J-1, index 14.

The compliance to those reference contour(s) shall be recorded in the technical documentation defined in clause 4.2.12 of this TSI.

- (5) For electric units, the pantograph gauge shall be verified by calculation according to the specification referenced in Appendix J-1, index 14, clause A.3.12 to ensure that the pantograph envelope complies with the mechanical kinematic pantograph gauge which in itself is determined according to Appendix D of TSI ENE, and depends on the choice made for the pantograph head geometry: the two permitted possibilities are defined in clause 4.2.8.2.9.2 of this TSI.

▼B

The voltage of the power supply is considered in the infrastructure gauge in order to ensure the proper insulation distances between the pantograph and fixed installations.

- (6) The pantograph sway as specified in clause 4.2.10 of TSI ENE and used for the mechanical kinematic gauge calculation shall be justified by calculations or measurements as set out in the specification referenced in Appendix J-1, index 14.

For units designed to be operated on track gauge of 1 520 mm system:

- (7) The static contour of the vehicle shall be within the ‘T’ uniform vehicle gauge; the reference contour for infrastructure is the ‘S’ gauge. This contour is specified in Appendix B.
- (8) For electric units the pantograph gauge shall be verified by calculation to ensure that the pantograph envelope complies with the mechanical static pantograph gauge which is defined in Appendix D of TSI ENE; the choice made for the pantograph head geometry shall be taken into account: the permitted possibilities are defined in clause 4.2.8.2.9.2 of this TSI.

4.2.3.2. Axle load and wheel load

4.2.3.2.1. Axle load parameter

- (1) The axle load is an interface parameter between the unit and the infrastructure. The axle load is a performance parameter of the infrastructure specified in clause 4.2.1 of the INF TSI and depends on the traffic code of the line. It has to be considered in combination with the axle spacing, with the train length and with the maximum allowed speed for the unit on the considered line.
- (2) The following characteristics to be used as an interface to the infrastructure shall be part of the general documentation produced when the unit is assessed, and described in clause 4.2.12.2 of this TSI:
- The mass per axle (for each axle) for the three load conditions (as defined and required to be part of the documentation in clause 4.2.2.10 of this TSI).
 - The position of the axles along the unit (axle spacing).
 - The length of the unit.
 - The maximum design speed (as required to be part of the documentation in clause 4.2.8.1.2 of this TSI).
- (3) Use of this information at operational level for compatibility check between rolling stock and infrastructure (outside the scope of this TSI):

▼B

The axle load of each individual axle of the unit to be used as interface parameter to the infrastructure has to be defined by the railway undertaking as required in clause 4.2.2.5 of the TSI OPE, considering the expected load for the intended service (not defined when the unit is assessed). The axle load in load condition 'design mass under exceptional payload' represents the maximum possible value of the axle load mentioned above. The maximum load considered for the design of the brake system defined in clause 4.2.4.5.2 has also to be considered.

4.2.3.2.2. Wheel load

- (1) The ratio of wheel load difference per axle $D_{qj} = (Q_l - Q_r)/(Q_l + Q_r)$, shall be evaluated by wheel load measurement, considering the load condition 'design mass in working order'. Wheel load difference higher than 5 % of the axle load for that wheelset are allowed only if demonstrated as acceptable by the test to prove safety against derailment on twisted track specified in the clause 4.2.3.4.1 of this TSI.
- (2) The conformity assessment procedure is described in clause 6.2.3.2 of this TSI.
- (3) For units with axle load in design mass under normal payload lower or equal to 22,5 tons and a worn wheel diameter higher than or equal to 470 mm, the wheel load over the wheel diameter (Q/D) shall be lower or equal to 0,15 kN/mm, as measured for a minimum worn wheel diameter and design mass under normal payload.

4.2.3.3. Rolling Stock parameters which influence ground based systems

4.2.3.3.1 Rolling Stock characteristics for the compatibility with train detection systems

- (1) For units designed to be operated on other track gauges than the 1 520 mm system, the set of rolling stock characteristics for compatibility with train detection target systems are given in clauses 4.2.3.3.1.1, 4.2.3.3.1.2 and 4.2.3.3.1.3.

Reference is made to clauses of the specification referenced in Appendix J-2, index 1 of this TSI (also referenced in Annex A, Index 77 of CCS TSI).

- (2) The set of characteristics the rolling stock is compatible with shall be recorded in the technical documentation described in clause 4.2.12 of this TSI.

4.2.3.3.1.1 Rolling stock characteristics for compatibility with train detection system based on track circuits

— **Vehicle geometry**

- (1) The maximum distance between 2 consecutive axles is specified in the specification referenced in Appendix J-2, index 1, clause 3.1.2.1. (distance a_1 in Figure 1).

▼B

- (2) The maximum distance between buffer end and first axle is specified in the specification referenced in Appendix J-2, index 1, clauses 3.1.2.5 and 6. (distance b1 in Figure 1).
- (3) The minimum distance between end axles of a unit is specified in the specification referenced in Appendix J-2, index 1, clause 3.1.2.4.

— Vehicle design

- (4) The minimum axle load in all load conditions is specified in the specification referenced in Appendix J-2, index 1, clause 3.1.7.
- (5) The electrical resistance between the running surfaces of the opposite wheels of a wheelset is specified in the specification referenced in Appendix J-2, index 1, clause 3.1.9 and the method to measure is specified in the same clause.
- (6) For electric units equipped with a pantograph, the minimum impedance between pantograph and each wheel of the train is specified in the specification referenced in Appendix J-2, index 1, clause 3.2.2.1.

— Isolating emissions

- (7) The limitations of use of sanding equipment are given in the specification referenced in Appendix J-2, index 1, clause 3.1.4; 'sand characteristics' is part of in this specification.

In case where an automatic sanding function is provided, it shall be possible for the driver to suspend its use on particular points of the track identified in operating rules as non-compatible with sanding.

- (8) The limitations of use of composite brake blocks are given in the specification referenced in Appendix J-2, index 1, clause 3.1.6.

— EMC

- (9) The requirements related to electromagnetic compatibility are specified in the specification referenced in Appendix J-2, index 1, clauses 3.2.1 and 3.2.2.
- (10) The electromagnetic interference limit levels rising from traction currents are specified in the specification referenced in Appendix J-2, index 1, clause 3.2.2.

4.2.3.3.1.2 Rolling stock characteristics for compatibility with train detection system based on axle counters

— Vehicle geometry

- (1) The maximum distance between 2 consecutive axles is specified in the specification referenced in Appendix J-2, index 1, clause 3.1.2.1.
- (2) The minimum distance between 2 consecutive axles of the train is specified in the specification referenced in Appendix J-2, index 1, clause 3.1.2.2.
- (3) At the end of a unit intended to be coupled, the minimum distance between end and first axle of the unit is half of the value specified in the specification referenced in Appendix J-2, index 1, clause 3.1.2.2.

▼B

- (4) The maximum distance between end and first axle is specified in the specification referenced in Appendix J-2, index 1, clause 3.1.2.5 & 6 (distance b1 in Figure 1).

— **Wheel geometry**

- (5) Wheel geometry is specified in the clause 4.2.3.5.2.2 of the present TSI.
- (6) The minimum wheel diameter (speed dependant) is specified in the specification referenced in Appendix J-2, index 1, clause 3.1.3

— **Vehicle design**

- (7) The metal-free space around wheels is specified in the specification referenced in Appendix J-2, index 1, clause 3.1.3.5.
- (8) The characteristics of the wheel material regarding magnetic field is specified in the specification referenced in Appendix J-2, index 1, clause 3.1.3.6.

— **EMC**

- (9) The requirements related to electromagnetic compatibility are specified in specification referenced in Appendix J-2, index 1, clauses 3.2.1 and 3.2.2.
- (10) The electromagnetic interference limit levels rising from the use of eddy current or magnetic track brakes are specified in the specification referenced in Appendix J-2, index 1, clause 3.2.3.

4.2.3.3.1.3 Rolling stock characteristics for compatibility with loop equipment

— **Vehicle design**

- (1) The vehicle metal construction is specified in the specification referenced in Appendix J-2, index 1, clause 3.1.7.2.

4.2.3.3.2 Axle bearing condition monitoring

- (1) Axle bearing condition monitoring objective is to detect deficient axle box bearings.
- (2) For units of maximum design speed higher than or equal to 250 km/h, on board detection equipment shall be provided.
- (3) For units of maximum design speed lower than 250 km/h, and designed to be operated on others track gauge systems than the 1 520 mm system, axle bearing condition monitoring shall be provided and be achieved either by on board equipment (according to specification in clause 4.2.3.3.2.1) or by using track side equipment (according to specification in clause 4.2.3.3.2.2).
- (4) The fitment of on board system or/and the compatibility with track side equipment shall be recorded in the technical documentation described in clause 4.2.12 of this TSI.

▼ B

- 4.2.3.3.2.1. Requirements applicable to on board detection equipment
- (1) This equipment shall be able to detect a deterioration of any of the axle box bearings of the unit.
 - (2) The bearing condition shall be evaluated either by monitoring its temperature, or its dynamic frequencies or some other suitable bearing condition characteristic.
 - (3) The detection system shall be located entirely on board the unit, and diagnosis messages shall be made available on board.
 - (4) The diagnosis messages delivered shall be described, and shall be taken into account in the operating documentation described in clause 4.2.12.4 of this TSI, and in the maintenance documentation described in clause 4.2.12.3 of this TSI.

- 4.2.3.3.2.2. Rolling stock requirements for compatibility with trackside equipment
- (1) For units designed to be operated on the 1 435 mm system, the zone visible to the trackside equipment on rolling stock shall be the area as defined in the specification referenced in Appendix J-1, index 15.
 - (2) For units designed to be operated on other track gauges a specific case is declared where relevant (harmonised rule available for the concerned network).

4.2.3.4. Rolling stock dynamic behaviour

4.2.3.4.1. Safety against derailment running on twisted track

- (1) The unit shall be designed to ensure safe running on twisted track, taking into account specifically the transition phase between canted and level track and cross level deviations.
- (2) The conformity assessment procedure is described in clause 6.2.3.3 of this TSI.

This conformity assessment procedure is applicable for axle loads in the range of those mentioned in the clause 4.2.1 of the TSI INF and in the specification referenced in Annex J-1, index 16.

It is not applicable to vehicle designed for higher axle load, such cases may be covered by national rules or by the procedure for innovative solution described in article 10 and Chapter 6 of this TSI.

4.2.3.4.2. Running dynamic behaviour

- (1) This clause is applicable to units designed for a speed higher than 60 km/h, except to on-track machines for which the requirements are set out in Appendix C, clause C.3 and except units designed to be operated on the 1 520 mm track gauge for which the corresponding requirements are considered as 'open point'.
- (2) The dynamic behaviour of a vehicle has a strong influence on running safety and track loading. It is an essential function for safety, covered by the requirements of this clause.

▼B

(a) Technical requirements

- (3) The unit shall run safely and produce an acceptable level of track loading when operated within the limits defined by the combination(s) of speed and cant deficiency under the reference conditions set out in the technical document referenced in Appendix J-2, index 2.

This shall be assessed by verifying that limit values specified below in clauses 4.2.3.4.2.1 and 4.2.3.4.2.2 of this TSI are respected; the conformity assessment procedure is described in clause 6.2.3.4 of this TSI.

- (4) The limit values and conformity assessment mentioned in point 3 are applicable for axle loads in the range of those mentioned in the clause 4.2.1 of the TSI INF and in the specification referenced in Annex J-1, index 16.

They are not applicable to vehicles designed for higher axle load, as harmonised track loading limit values are not defined; such cases may be covered by national rules or by the procedure for innovative solution described in article 10 and Chapter 6 of this TSI.

- (5) The running dynamic behaviour test report (including limits of use and track loading parameters) shall be stated in the technical documentation described in clause 4.2.12 of this TSI.

Track loading parameters (including the additional ones Y_{max} , B_{max} and the B_{gst} where relevant) to be recorded are defined in the specification referenced in Appendix J-1, index 16 with the modifications as set out in the technical document referenced in Appendix J-2, index 2.

(b) Additional requirements when an active system is used

- (6) When active systems (based on software or programmable controller controlling actuators) are used, the functional failure has typical credible potential to lead directly to 'fatalities' for both of the following scenarios:

1. failure in the active system leading to a non-compliance with limit values for running safety (defined in accordance with clauses 4.2.3.4.2.1 and 4.2.3.4.2.2);
2. failure in the active system leading to a vehicle outside of the kinematic reference contour of the carbody and pantograph, due to tilting angle (sway) leading to non-compliance with the values assumed as set out in clause 4.2.3.1.

Considering this severity of the failure consequence it shall be demonstrated that the risk is controlled to an acceptable level.

The demonstration of compliance (conformity assessment procedure) is described in clause 6.2.3.5 of this TSI.

▼B

(c) Additional requirements when an instability detection system is installed (option)

- (7) The instability detection system shall provide information regarding the need to take operative measures (such as reduction of speed etc.), and it shall be described in the technical documentation. The operative measures shall be described in the operating documentation set out in clause 4.2.12.4 of this TSI.

4.2.3.4.2.1. Limit values for running safety

- (1) The limit values for running safety which the unit shall meet are specified in the specification referenced in Appendix J-1, index 17, and additionally for trains intended to be operated with a cant deficiencies > 165 mm in the specification referenced in Appendix J-1, index 18, with the modifications as set out in the technical document referenced in Appendix J-2, index 2.

4.2.3.4.2.2. Track loading limit values

- (1) The limit values for track loading which the unit shall meet (when assessing with the normal method) are specified in the specification referenced in Appendix J-1, index 19 with the modifications as set out in the technical document referenced in Appendix J-2, index 2.
- (2) In case the estimated values exceed the limit values expressed above, the operational conditions for the rolling stock (e.g. maximum speed, cant deficiency) may be adjusted taking into account track characteristics (e.g. curve radius, cross section of the rail, sleeper spacing, track maintenance intervals).

4.2.3.4.3. Equivalent conicity

4.2.3.4.3.1. Design values for new wheel profiles

- (1) The clause 4.2.3.4.3 is applicable to all units, except for unit designed to be operated on the 1 520 mm or 1 600 mm track gauge for which the corresponding requirements are an open point.
- (2) A new wheel profile and the distance between active faces of the wheels shall be checked in respect of target equivalent conicities using the calculation scenarios provided in clause 6.2.3.6 of this TSI in order to establish the suitability of the new proposed wheel profile for infrastructure in accordance with the TSI INF.
- (3) Units equipped with independently rotating wheels are exempt from these requirements.

4.2.3.4.3.2. In-service values of wheelset equivalent conicity

- (1) The combined equivalent conicities the vehicle is designed for, as verified by the demonstration of conformity of the running dynamic behaviour specified in clause 6.2.3.4 of this TSI, shall be specified for in-service conditions in the maintenance documentation as set out in point 4.2.12.3.2, taking into account the contributions of wheel and rail profiles.

▼ B

- (2) If ride instability is reported, the railway undertaking and the Infrastructure Manager shall localise the section of the line in a joint investigation.
- (3) The railway undertaking shall measure the wheel profiles and the front-to-front distance (distance of active faces) of the wheelsets in question. The equivalent conicity shall be calculated using the calculation scenarios provided in clause 6.2.3.6 in order to check if compliance with the maximum equivalent conicity the vehicle was designed and tested for is met. If it is not the case, the wheel profiles have to be corrected.
- (4) If the wheelset conicity complies with the maximum equivalent conicity the vehicle was designed and tested for, a joint investigation by the railway undertaking and the infrastructure manager shall be undertaken to determine the characteristics reason for the instability.
- (5) Units equipped with independently rotating wheels are exempt from these requirements.

4.2.3.5. Running gear

4.2.3.5.1. Structural design of bogie frame

- (1) For units which include a bogie frame, the integrity of the structure of the bogie frame, axle box housing and all attached equipment shall be demonstrated based on methods as set out in the specification referenced in Appendix J-1, index 20.
- (2) The body to bogie connection shall comply with the requirements of the specification referenced in Appendix J-1, index 21.
- (3) The hypothesis taken to evaluate the loads due to bogie running (formulas and coefficients) in line with the specification referenced in Appendix J-1, index 20 shall be justified and documented in the technical documentation described in clause 4.2.12 of this TSI.

4.2.3.5.2. Wheelsets

- (1) For the purpose of this TSI, wheelsets are defined to include main parts ensuring the mechanical interface with the track (wheels and connecting elements: e.g. transverse axle, independent wheel axle) and accessories parts (axle bearings, axle boxes, gearboxes and brake discs).
- (2) The wheelset shall be designed and manufactured with a consistent methodology using a set of load cases consistent with load conditions defined in clause 4.2.2.10 of this TSI.

4.2.3.5.2.1. Mechanical and geometric characteristics of wheelsets

Mechanical behaviour of wheelsets

- (1) The mechanical characteristics of the wheelsets shall ensure the safe movement of rolling stock.

▼B

The mechanical characteristics cover:

- assembly
- mechanical resistance and fatigue characteristics

The conformity assessment procedure is described in clause 6.2.3.7 of this TSI.

Mechanical behaviour of axles

- (2) The characteristics of the axle shall ensure the transmission of forces and torque.

The conformity assessment procedure is described in clause 6.2.3.7 of this TSI.

Case of units equipped with independently rotating wheels

- (3) The characteristics of the end of axle (interface between wheel and running gear) shall ensure the transmission of forces and torque.

The conformity assessment procedure shall be in accordance with point (7) of clause 6.2.3.7 of this TSI.

Mechanical behaviour of the axle boxes

- (4) The axle box shall be designed with consideration of mechanical resistance and fatigue characteristics.

The conformity assessment procedure is described in clause 6.2.3.7 of this TSI.

- (5) Temperature limits shall be defined by testing and recorded in the technical documentation described in clause 4.2.12 of this TSI.

Axle bearing condition monitoring is defined in clause 4.2.3.3.2 of this TSI.

Geometrical dimensions of wheelsets

- (6) The geometric dimensions of the wheelsets (as defined in Figure 1) shall be compliant with limit values specified in Table 1 for the relevant track gauge.

These limit values shall be taken as design values (new wheelset) and as in-service limit values (to be used for maintenance purposes; see also clause 4.5 of this TSI).

Table 1

In-service limits of the geometric dimensions of wheelsets

Designation		Wheel diam. D (mm)	Minimum value (mm)	Maximum value (mm)
1 435 mm	Front-to-front dimension (S_R) $S_R = A_R + S_{d, \text{left}} + S_{d, \text{right}}$	$330 \leq D \leq 760$	1 415	1 426
		$760 < D \leq 840$	1 412	
		$D > 840$	1 410	
	Back to back distance (A_R)	$330 \leq D \leq 760$	1 359	1 363
		$760 < D \leq 840$	1 358	
		$D > 840$	1 357	

▼ B

Designation		Wheel diam. D (mm)	Minimum value (mm)	Maximum value (mm)
1 524 mm	Front-to-front dimension (S_R) $S_R = A_R + S_{d,left} + S_{d,right}$	$400 \leq D < 725$	1 506	1 509
		$D \geq 725$	1 487	1 514
	Back to back distance (A_R)	$400 \leq D < 725$	1 444	1 446
		$D \geq 725$	1 442	1 448
1 520 mm	Front-to-front dimension (S_R) $S_R = A_R + S_{d,left} + S_{d,right}$	$400 \leq D \leq 1\,220$	1 487	1 509
	Back to back distance (A_R)	$400 \leq D \leq 1\,220$	1 437	1 443
1 600 mm	Front-to-front dimension (S_R) $S_R = A_R + S_{d,left} + S_{d,right}$	$690 \leq D \leq 1\,016$	1 573	1 592
	Back to back distance (A_R)	$690 \leq D \leq 1\,016$	1 521	1 526
1 668 mm	Front-to-front dimension (S_R) $S_R = A_R + S_{d,left} + S_{d,right}$	$330 \leq D < 840$	1 648	1 659
		$840 \leq D \leq 1\,250$	1 643	1 659
	Back to back distance (A_R)	$330 \leq D < 840$	1 592	1 596
		$840 \leq D \leq 1\,250$	1 590	1 596

The dimension A_R is measured at the height of the top of rail. The dimensions A_R and S_R shall be complied with in laden and tare conditions. Smaller tolerances within the above limits may be specified by the manufacturer in the maintenance documentation for in-service values. The dimensions S_R is measured at 10 mm above tread datum (as shown in Figure 2).

Figure 1
Symbols for wheelsets

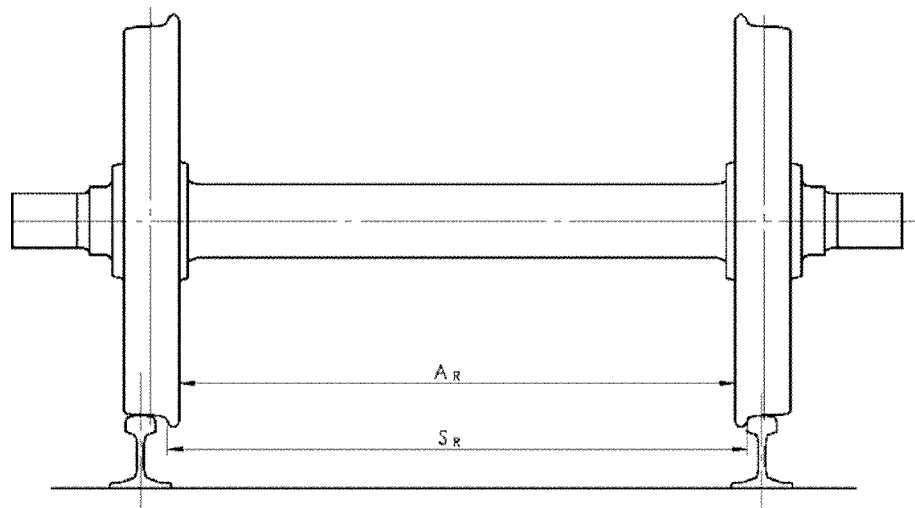

▼ B

4.2.3.5.2.2 Mechanical and geometrical characteristics of wheels

Mechanical behaviour of wheels

- (1) The characteristics of the wheels shall ensure the safe movement of rolling stock and contribute to the guidance of the rolling stock.

The conformity assessment procedure is described in clause 6.1.3.1 of this TSI.

Geometrical dimensions of wheels

- (2) The geometrical dimensions of the wheels (as defined in Figure 2) shall be compliant with limit values specified in Table 2. These limit values shall be taken as design values (new wheel) and as in-service limit values (to be used for maintenance purposes; see also clause 4.5).

Table 2

In-service limits of the geometric dimensions of wheel

Designation	Wheel diameter D (mm)	Minimum value (mm)	Maximum value (mm)
Width of the rim ($B_R + \text{Burr}$)	$D \geq 330$	133	145
Thickness of the flange (S_d)	$D > 840$	22	33
	$760 < D \leq 840$	25	
	$330 \leq D \leq 760$	27,5	
Height of the flange (S_h)	$D > 760$	27,5	36
	$630 < D \leq 760$	29,5	
	$330 \leq D \leq 630$	31,5	
Face of flange (q_R)	≥ 330	6,5	

Figure 2

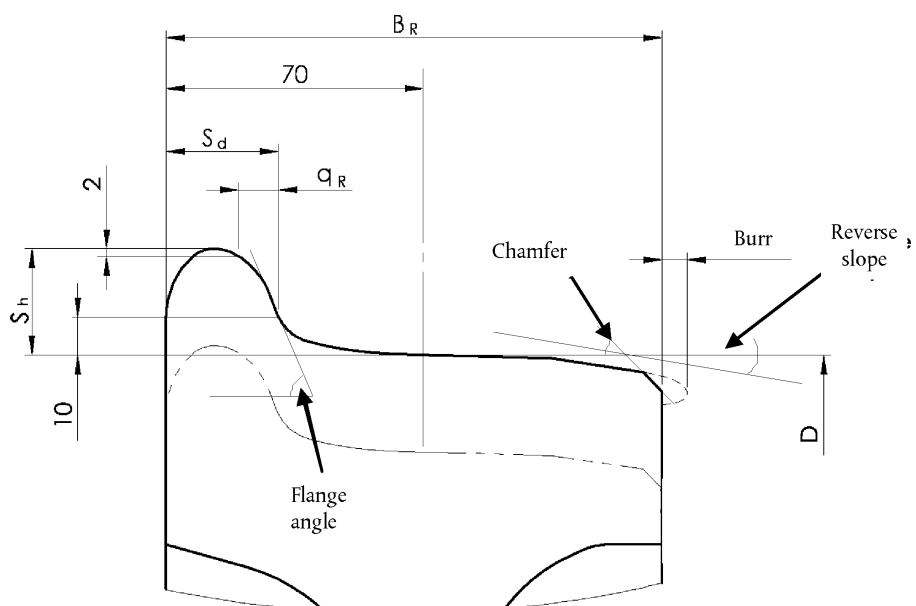
Symbols for wheels

▼B

- (3) Units equipped with independently rotating wheels shall, in addition to the requirements in this clause dealing with wheels, meet the requirements in this TSI for geometrical characteristics of wheelsets defined in clause 4.2.3.5.2.1.

4.2.3.5.2.3 Variable gauge wheelsets

- (1) This requirement is applicable to units equipped with variable gauge wheelsets with changeover between the track gauge 1 435 mm and another track gauge in the scope of this TSI.
- (2) The changeover mechanism of the wheelset shall ensure the safe locking in the correct intended axial position of the wheel.
- (3) External visual verification of the state of the locking system (locked or unlocked) shall be possible.
- (4) If the wheelset is equipped with brake equipment, the position and locking in the correct position of this equipment shall be ensured.
- (5) The conformity assessment procedure of the requirements specified in this clause is an open point.

4.2.3.6. Minimum curve radius

- (1) The minimum curve radius to be negotiated shall be 150 m for all units.

4.2.3.7. Life guards

- (1) This requirement applies to units fitted with a driving cab.
- (2) The wheels shall be protected against damages caused by minor items on the rails. This requirement can be met by life guards in front of the wheels of the leading axle.
- (3) The height of the lower end of the life guard above the plain rail shall be:

— 30 mm minimum in all conditions

— 130 mm maximum in all conditions

taking into account in particular wheel wear and suspension compression.

- (4) If an obstacle deflector specified in clause 4.2.2.5 has its lower edge at less than 130 mm above the plain rail in all conditions, it fulfils the functional requirement of the life guards and therefore it is permissible not to fit life guards.
- (5) A life guard shall be designed to withstand a minimum longitudinal static force without permanent deformation of 20 kN. This requirement shall be verified by a calculation.
- (6) A life guard shall be designed so that, during plastic deformation, it does not foul the track or running gear and that contact with the wheel tread, if it occurs, does not pose a risk of derailment.

▼ B4.2.4. *Braking*4.2.4.1. *General*

- (1) The purpose of the train braking system is to ensure that the train's speed can be reduced or maintained on a slope, or that the train can be stopped within the maximum allowable braking distance. Braking also ensures the immobilisation of a train.
- (2) The primary factors that influence the braking performance are the braking power (braking force production), the train mass, the train rolling resistance, the speed, the available adhesion.
- (3) Individual unit performance for units operated in various train formations is defined so that the overall braking performance of the train can be derived.
- (4) The braking performance is determined by deceleration profiles (deceleration = F(speed) and equivalent response time).

Stopping distance, brake weight percentage (also called 'lambda' or 'braked mass percentage'), braked mass may also be used, and can be derived (directly or via stopping distance) from deceleration profiles by a calculation.

The braking performance could vary with the mass of the train or vehicle.

- (5) The minimum train braking performance required to operate a train on a line at an intended speed is dependent on the line characteristics (signalling system, maximum speed, gradients, line safety margin) and is a characteristic of the infrastructure.

The train or vehicle main data characterising the braking performance is defined in the clause 4.2.4.5 of this TSI.

4.2.4.2. *Main functional and safety requirements*4.2.4.2.1. *Functional requirements*

The following requirements apply to all units.

Units shall be equipped with:

- (1) a main brake function used during operation for service and emergency braking.
- (2) a parking brake function used when the train is parked, allowing the application of a brake force without any available energy on board for an unlimited period of time.

The main brake function of a train shall be:

- (3) continuous: the brake application signal is transmitted from a central command to the whole train by a control line.
- (4) automatic: an inadvertent disruption (loss of integrity, line de-energised, etc.) of the control line leads to brake activation on all vehicles of the train.
- (5) It is permitted to complement the main brake function by additional brake systems described in clause 4.2.4.7 (dynamic brake — braking system linked to traction system) and/or clause 4.2.4.8 (braking system independent of adhesion conditions).

▼B

- (6) The dissipation of the braking energy shall be considered in the design of the braking system, and shall not cause any damage to the components of the braking system in normal operation conditions; this shall be verified by a calculation as specified in clause 4.2.4.5.4 of this TSI.

The temperature reached around the brake components shall also be considered in the design of the rolling stock.

- (7) The design of the brake system shall include means for monitoring and tests as specified in clause 4.2.4.9 of this TSI.

The requirements below in this clause 4.2.4.2.1 apply at train level to units for which the operating formation(s) is (are) defined at design stage (i.e. unit assessed in fixed formation, unit assessed in predefined formation(s), locomotive operated alone).

- (8) The braking performance shall be consistent with safety requirements expressed in clause 4.2.4.2.2 in case of inadvertent disruption of the brake control line, and in the event of the braking energy supply being disrupted, the power supply failing or other energy source failure.

- (9) In particular, there shall be sufficient braking energy available on board the train (stored energy), distributed along the train consistent with the design of the brake system, to ensure the application of the required brake forces.

- (10) Successive applications and releases of the brake shall be considered in the design of the braking system (inexhaustibility).

- (11) In case of unintentional train separation, the two parts of the train shall be brought to a standstill; the braking performances on the two parts of the train are not required to be identical to the braking performance in normal mode.

- (12) In the event of the braking energy supply being disrupted or the power supply failing, it shall be possible to hold in a stationary position a unit with maximum braking load (as defined in clause 4.2.4.5.2) on a 40 ‰ gradient by using the friction brake of the main brake system alone, for at least two hours.

- (13) The unit braking control system shall have three control modes:

— emergency braking: application of a predefined brake force in a predefined maximum response time in order to stop the train with a defined level of brake performance.

— service braking: application of an adjustable brake force in order to control the speed of the train, including stop and temporary immobilisation.

— parking braking: application of a brake force to maintain the train (or the vehicle) in permanent immobilisation in a stationary position, without any available energy on board.

▼B

- (14) A brake application command, whatever its control mode, shall take control of the brake system, even in case of active brake release command; this requirement is permitted not to apply when intentional suppression of the brake application command is given by the driver (e.g. passenger alarm override, uncoupling...).
- (15) For speeds higher than 5 km/h, the maximum jerk due to the use of brakes shall be lower than 4 m/s³. The jerk behaviour may be derived from the calculation and from the evaluation of the deceleration behaviour as measured during the brake tests (as described in the clauses 6.2.3.8 and 6.2.3.9).

4.2.4.2.2. Safety requirements

- (1) The braking system is the means to stop a train, and therefore contributes to the safety level of the railway system.

The functional requirements expressed in clause 4.2.4.2.1 contribute to ensure safe functioning of the braking system; nevertheless, a risk based analysis is necessary to evaluate the braking performance, as many components are involved.

- (2) For the hazardous scenarios considered, the corresponding safety requirements shall be met, as defined in the Table 3 below.

Where a severity is specified within this table, it shall be demonstrated that the corresponding risk is controlled to an acceptable level, considering the functional failure with their typical credible potential to lead directly to that severity as defined within the table.

Table 3

Braking system — safety requirements

	Safety requirement to be met	
Functional failure with its hazardous scenario	Associated severity/ Consequence to be prevented	Minimum allowable number of combinations of failures

No 1

Applies to units fitted with a cab (brake command)		
After activation of an emergency brake command no deceleration of the train due to failure in the brake system (complete and permanent loss of the brake force). Note: activation by the driver or by the CCS system to be considered. Activation by passengers (alarm) not relevant for the present scenario.	Fatalities	2 (no single failure is accepted)

▼ B

		Safety requirement to be met	
	Functional failure with its hazardous scenario	Associated severity/ Consequence to be prevented	Minimum allowable number of combinations of failures

No 2

Applies to units equipped with traction equipment			
	After activation of an emergency brake command, no deceleration of the train due to failure in the traction system (Traction force \geq Brake force).	Fatalities	2 (no single failure is accepted)

No 3

Applies to all units			
	After activation of an emergency brake command, the stopping distance is longer than the one in normal mode due to failure(s) in the brake system. Note: the performance in the normal mode is defined in clause 4.2.4.5.2.	NA	single point(s) failure(s) leading to the longest calculated stopping distance shall be identified, and the increase of the stopping distance compared to the normal mode (no failure) shall be determined.

No 4

Applies to all units			
	After activation of a parking brake command, no parking brake force applied (complete and permanent loss of the parking brake force).	NA	2 (no single failure is accepted)

Additional brake systems shall be considered in the safety study under the conditions specified in clauses 4.2.4.7 and 4.2.4.8.

The demonstration of compliance (conformity assessment procedure) is described in clause 6.2.3.5 of this TSI.

4.2.4.3. Type of brake system

- (1) Units designed and assessed to be operated in general operation (various formations of vehicles from different origins; train formation not defined at design stage) on other track gauge systems than the 1 520 mm system shall be fitted with a brake system with a brake pipe compatible with the UIC brake system. To this end, the specification referenced in Appendix J-1, index 22. 'Requirements for the brake system of trains hauled by a locomotive' specifies the principles to be applied.

▼B

This requirement is set to ensure technical compatibility of the brake function between vehicles of various origins in a train.

- (2) There is no requirement on the type of brake system for units (trainsets or vehicles) assessed in fixed or predefined formation.

4.2.4.4. Brake command

4.2.4.4.1. Emergency braking command

- (1) This clause applies to units fitted with a driver's cab.
- (2) At least two independent emergency brake command devices shall be available, allowing the activation of the emergency brake by a simple and single action from the driver in his normal driving position, using one hand.

The sequential activation of these two devices may be considered in the demonstration of compliance to the safety requirement No 1 of Table 3 of clause 4.2.4.2.2.

One of these devices shall be a red punch button (mushroom push button).

The emergency brake position of these two devices when activated shall be self-locking by a mechanical device; unlocking this position shall be possible only by an intentional action.

- (3) The activation of the emergency brake shall also be possible by the Control-Command and signalling on-board system, as defined in the TSI CCS.
- (4) Unless the command is cancelled, the emergency brake activation shall lead permanently, automatically to the following actions:
 - transmission of an emergency brake command along the train by the brake control line,
 - cut-off of all tractive effort in less than 2 seconds; this cut-off shall not be able to be reset until the traction command is cancelled by the driver,
 - an inhibition of all 'release brake' commands or actions.

4.2.4.4.2. Service braking command

- (1) This clause applies to units fitted with a driver's cab.
- (2) The service brake function shall allow the driver to adjust (by application or release) the brake force between a minimum and a maximum value in a range of at least 7 steps (including brake release and maximum brake force), in order to control the speed of the train.

▼B

- (3) The service braking command shall be active only in one location in a train. To meet this requirement, it shall be possible to isolate the service braking function of the other service braking command(s) of the unit(s) part of a train formation, as defined for fixed and predefined formations.
- (4) When the speed of the train is higher than 15 km/h, the service brake activation by the driver shall lead automatically to the cut-off of all tractive effort; this cut-off shall not be reset until the traction command is cancelled by the driver.

Notes:

- in case of service brake and traction controlled by automatic speed regulation, the traction cut-off is not required to be cancelled by the driver.
- a friction brake may be used intentionally at speed higher than 15 km/h with traction for specific purpose (de-icing, cleaning of brake components...); it shall not be possible to use these particular functionalities in case of emergency or service brake activation.

4.2.4.4.3 Direct braking command

- (1) Locomotives (units designed to haul freight wagons or passenger carriages) assessed for general operation shall be fitted with a direct brake system.
- (2) The direct brake system shall allow the application of a brake force on the concerned unit(s) independently of the main brake command, with other unit(s) of the train remaining without brake applied.

4.2.4.4.4 Dynamic braking command

If a unit is equipped with a dynamic brake system:

- (1) It shall be possible to prevent the use of regenerative braking on electric units so that there is no return of energy to the overhead contact line when driving on a line which does not allow that.

See also clause 4.2.8.2.3 for regenerative brake.

- (2) It is permitted to use a dynamic brake independently from other brake systems, or together with other brake systems (blending).
- (3) Where on locomotives the dynamic brake is used independently from other brake systems, it shall be possible to limit the maximum value and rate of variation of the dynamic brake effort to predefined values.

Note: this limitation relates to the forces transmitted to the track when locomotive(s) is (are) integrated in a train. It may be applied at operating level by setting the values necessary for compatibility with a particular line (e.g. line with high gradient and low curve radius).

▼ B

4.2.4.4.5 Parking braking command

- (1) This clause applies to all units.
- (2) The parking braking command shall lead to the application of a defined brake force for an unlimited period of time, during which a lack of any energy on board may occur.
- (3) It shall be possible to release the parking brake at standstill, including for rescue purposes.
- (4) For units assessed in fixed or predefined formations, and for locomotives assessed for general operation, the parking brake command shall be activated automatically when the unit is switched off. For other units, the parking brake command shall be either activated manually, or activated automatically when the unit is switched off.

Note: the application of the parking brake force may depend on the status of the main brake function; it shall be effective when the energy on board to apply the main brake function is lost or is going to increase or decrease (after having switched on or off the unit).

4.2.4.5. Braking performance

4.2.4.5.1 General requirements

- (1) The unit (trainset or vehicle) braking performance (deceleration = $F(\text{speed})$ and equivalent response time) shall be determined by calculation as defined in the specification referenced in Appendix J-1, index 23, considering a level track.

Each calculation shall be performed for wheel diameters corresponding to new, half-worn and worn wheels, and shall include the calculation of the required wheel/rail adhesion level (see clause 4.2.4.6.1).

- (2) The friction coefficients used by friction brake equipment and considered in the calculation shall be justified (see the specification referenced in Appendix J-1, index 24).
- (3) The braking performance calculation shall be performed for the two control modes: emergency brake and maximum service brake.
- (4) The braking performance calculation shall be performed at design stage, and shall be revised (correction of parameters) after the physical tests required in the clauses 6.2.3.8 and 6.2.3.9, in order to be consistent with test results.

The final braking performance calculation (consistent with test results) shall be part of the technical documentation specified in clause 4.2.12.

- (5) The maximum average deceleration developed with all brakes in use, including the brake independent of wheel/rail adhesion, shall be lower than $2,5 \text{ m/s}^2$; this requirement is linked to the longitudinal resistance of the track.

▼ B

4.2.4.5.2 Emergency braking

Response time:

- (1) For units assessed in fixed formation(s) or predefined formation(s), the equivalent response time (*) and the delay time (*) evaluated on the total emergency braking force developed in case of the emergency brake command shall be lower than the following values:

— Equivalent response time:

— 3 seconds for units of maximum design speed higher or equal to 250 km/h

— 5 seconds for other units

— Delay time: 2 seconds

- (2) For units designed and assessed for general operation, the response time shall be as specified for the UIC brake system (see also clause 4.2.4.3: the brake system shall be compatible with the UIC brake system).

(*) to be evaluated on the total brake force, or on pressure in brake cylinders in case of pneumatic brake system; definition according to the specification referenced in Appendix J-1, index 25, clause 5.3.3.

Calculation of the deceleration:

- (3) For all units, the emergency braking performance calculation shall be performed in accordance with the specification referenced in Appendix J-1, index 26; the deceleration profile and stopping distances at the following initial speeds (if lower than the maximum design speed of the unit) shall be determined: 30 km/h; 100 km/h; 120 km/h; 140 km/h; 160 km/h; 200 km/h; 230 km/h; 300 km/h; maximum design speed of the unit.
- (4) For units designed and assessed for general operation, the brake weight percentage (λ) shall also be determined.

The specification referenced in Appendix J-1, index 25, clause 5.12 specifies how other parameters (brake weight percentage (λ), braked mass) can be derived from the calculation of the deceleration or from the stopping distance of the unit.

- (5) The emergency braking performance calculation shall be performed with a brake system in two different modes, and considering degraded conditions:

— Normal mode: no failure in the brake system and nominal value of the friction coefficients (corresponding to dry conditions) used by friction brake equipment. This calculation provides the braking performance normal mode.

▼ B

- Degraded mode: corresponding to the failures considered in clause 4.2.4.2.2, hazard no. 3, and nominal value of the friction coefficients used by friction brake equipment. Degraded mode shall consider possible single failures; to that end, the emergency braking performance shall be determined for the case of single point(s) failure(s) leading to the longest stopping distance, and the associated single failure shall be clearly identified (component involved and failure mode, failure rate if available).
- Degraded conditions: in addition, the emergency braking performance calculation shall be performed with reduced values of the friction coefficient, with consideration of limit values for temperature and humidity (see the specification referenced in Appendix J-1, index 27, clause 5.3.1.4).

Note: these different modes and conditions have to be considered particularly when advanced Control Command and Signalling systems (such as ETCS) are implemented, aiming at optimising the railway system.

- (6) The emergency braking performance calculation shall be performed for the three following load conditions:
- minimum load: ‘design mass in working order’ (as described in clause 4.2.2.10)
 - normal load: ‘design mass under normal payload’ (as described in clause 4.2.2.10)
 - maximum braking load: load condition lower or equal to ‘design mass under exceptional payload’ (as described in clause 4.2.2.10)
- In case this load condition is lower than ‘design mass under exceptional payload’, it shall be justified and documented in the general documentation described in clause 4.2.12.2.
- (7) Tests shall be performed to validate the emergency braking calculation, according to the conformity assessment procedure specified in clause 6.2.3.8.
- (8) For each load condition, the lowest result (i.e. leading to longest stopping distance) of the ‘emergency braking performance in normal mode’ calculations at the design maximum speed (revised according to the results of tests required above) shall be recorded in the technical documentation defined in clause 4.2.12.2 of this TSI.
- (9) Additionally, for units assessed in fixed or predefined formation of design maximum speed higher than or equal to 250 km/h, the stopping distance in case of ‘emergency braking performance in normal mode’ shall not exceed the following values for the load condition ‘normal load’:

▼B

- 5 360 m from the speed of 350 km/h (if \leq design maximum speed).
- 3 650 m from the speed 300 km/h (if \leq design maximum speed).
- 2 430 m from the speed 250 km/h.
- 1 500 m from the speed 200 km/h.

4.2.4.5.3. Service braking

Calculation of the deceleration:

- (1) For all units, the maximum service braking performance calculation shall be performed in accordance with the specification referenced in Appendix J-1, index 28 with a brake system in normal mode, with nominal value of the friction coefficients used by friction brake equipment for the load condition 'design mass under normal payload' at the design maximum speed.
- (2) Tests shall be performed to validate the maximum service braking calculation, according to the conformity assessment procedure specified in clause 6.2.3.9.

Maximum service braking performance:

- (3) When the service braking has higher design performance capability than the emergency braking, it shall be possible to limit the maximum service braking performance (by design of the braking control system, or as a maintenance activity) at a level lower than the emergency braking performance.

Note: A Member State may ask the emergency braking performance to be at a higher level than the maximum service braking performance for safety reasons, but in any case it cannot prevent the access to a railway undertaking using a higher maximum service braking performance, unless that Member State is able to demonstrate that the national safety level is endangered.

4.2.4.5.4 Calculations related to thermal capacity

- (1) This clause applies to all units.
- (2) For OTMs, it is allowed to verify this requirement by temperature measurements on wheels and brake equipment.
- (3) The brake energy capacity shall be verified by calculation showing that the braking system in normal mode is designed to withstand the dissipation of the braking energy. The reference values used in this calculation for the components of the braking system that dissipate energy shall either be validated by a thermal test or by previous experience.

▼B

This calculation shall include the scenario consisting of 2 successive emergency brake applications from the maximum speed (time interval corresponding to the time needed to accelerate the train up to the maximum speed) on level track for the load condition 'maximum braking load'.

In case of unit that cannot be operated alone as a train, the time interval between 2 successive emergency brake applications used in the calculation shall be reported.

- (4) The maximum line gradient, associated length and operating speed for which the brake system is designed in relation with brake thermal energy capacity shall also be defined by a calculation for the load condition 'maximum braking load', with the service brake being used to maintain the train at a constant operating speed.

The result (maximum line gradient, associated length and operating speed) shall be recorded in the rolling stock documentation defined in clause 4.2.12 of this TSI.

The following 'reference case' for the slope to be considered is suggested: maintain the speed of 80 km/h on a slope of 21 ‰ constant gradient over a distance of 46 km. If this reference case is used, the documentation may only mention the compliance to it.

- (5) For units assessed in fixed and predefined formation of design maximum speed higher than or equal to 250 km/h, they shall additionally be designed to operate with braking system in normal mode and load condition 'maximum braking load' at speed equal to 90 % of the maximum operating speed on maximum descending gradient of 25 ‰ during 10 km, and on maximum descending gradient of 35 ‰ during 6 km.

4.2.4.5.5 Parking brake

Performance:

- (1) A unit (train or vehicle) in load condition 'design mass in working order' without any power supply available, and stationary permanently on a 40 ‰ gradient, shall be kept immobilised.
- (2) Immobilisation shall be achieved by means of the parking brake function, and additional means (e.g. scotches) in case where the parking brake is unable to achieve the performance on its own; the required additional means shall be available on board the train.

Calculation:

- (3) The unit (train or vehicle) parking brake performance shall be calculated as defined in the specification referenced in Appendix J-1, index 29. The result (gradient where the unit is kept immobilised by the parking brake alone) shall be recorded in the technical documentation defined in clause 4.2.12 of this TSI.

▼B

4.2.4.6. Wheel rail adhesion profile — Wheel slide protection system

4.2.4.6.1 Limit of wheel rail adhesion profile

- (1) The braking system of a unit shall be designed so that emergency brake performance (dynamic brake included if it contributes to the performance) and the service brake performance (without dynamic brake) do not assume a calculated wheel/rail adhesion for each wheelset in the speed range > 30 km/h and < 250 km/h higher than 0,15 with the following exceptions:

— for units assessed in fixed or predefined formation(s) having 7 axles or less, the calculated wheel/rail adhesion shall not be higher than 0,13,

— for units assessed in fixed or predefined formation(s) having 20 axles or more the calculated wheel/rail adhesion for the load case ‘minimum load’ is permitted to be higher than 0,15, but shall not be higher than 0,17.

Note: for the load case ‘normal load’, there is no exception; the limit value of 0,15 applies.

This minimum number of axles may be reduced to 16 axles if the test required in Section 4.2.4.6.2 related to the efficiency of the WSP system is performed for the load case ‘minimum load’, and provides positive result.

In the speed range > 250 km/h and ≤ 350 km/h, the three limit values above shall decline linearly in order to be reduced by 0,05 at 350 km/h.

- (2) The above requirement shall also apply for a direct brake command described in clause 4.2.4.4.3.
- (3) The design of a unit shall not assume wheel/rail adhesion higher than 0,12 when calculating the parking brake performance.
- (4) These limits of wheel rail adhesion shall be verified by calculation with the smallest wheel diameter, and with the 3 load conditions considered in clause 4.2.4.5.2.

All values of adhesion shall be rounded to two decimal places.

4.2.4.6.2. Wheel slide protection system

- (1) A wheel slide protection system (WSP) is a system designed to make the best use of available adhesion by a controlled reduction and restoration of the brake force to prevent wheelsets from locking and uncontrolled sliding, thereby minimising the extension of stopping distances and possible wheel damage.

▼ B

Requirements on the presence and use of a WSP system on the unit:

- (2) Units designed for maximum service speed higher than 150 km/h shall be fitted with a wheel slide protection system.
- (3) Units equipped with brake blocks on wheel running surface with a brake performance which assumes in the speed range > 30 km/h a calculated wheel/rail adhesion higher than 0.12 shall be fitted with a wheel slide protection system.

Units not equipped with brake blocks on wheel running surface with a brake performance which assumes in the speed range > 30 km/h a calculated wheel/rail adhesion higher than 0.11 shall be fitted with a wheel slide protection system.

- (4) The requirement on the wheel slide protection system above shall apply to the two brake modes: emergency brake and service brake.

It shall also apply to the dynamic brake system, which is part of the service brake, and can be part of the emergency brake (see clause 4.2.4.7).

Requirements on the WSP system performance:

- (5) For units equipped with a dynamic braking system, a WSP system (if present according to the point above) shall control the dynamic brake force; when this WSP system is not available, the dynamic brake force shall be inhibited, or limited in order not to lead a wheel/rail adhesion demand higher than 0.15.
- (6) The wheel slide protection system shall be designed according to the specification referenced in Appendix J-1, index 30, clause 4; the conformity assessment procedure is specified in clause 6.1.3.2.
- (7) Requirements on performance at unit level:

If a unit is equipped with a WSP, a test shall be done to verify the efficiency of the WSP system (maximum extension of the stopping distance compared to stopping distance on dry rail) when integrated in the unit; the conformity assessment procedure is specified in clause 6.2.3.10.

The relevant components of the wheel slide protection system shall be considered in the safety analysis of the emergency brake function required in clause 4.2.4.2.2.

- (8) Wheel rotation monitoring system (WRM):

Units of design maximum speed higher or equal to 250 km/h shall be equipped with a wheel rotation monitoring system to advise the driver that an axle has seized; the wheel rotation monitoring system shall be designed according to the specification referenced in Appendix J-1, index 30, clause 4.2.4.3.

▼B**4.2.4.7. Dynamic brake — Braking system linked to traction system**

Where the braking performance of the dynamic brake or of braking system linked to the traction system is included in the performance of the emergency braking in normal mode defined in clause 4.2.4.5.2, the dynamic brake or the braking system linked to traction:

- (1) Shall be commanded by the main brake system control line (see clause 4.2.4.2.1).
- (2) Shall be subject to a safety analysis covering the hazard ‘after activation of an emergency command, complete loss of the dynamic brake force’.

This safety analysis shall be considered in the safety analysis required by the safety requirement N° 3 set out in clause 4.2.4.2.2 for the emergency brake function.

For electric units, in case the presence on-board the unit of the voltage delivered by the external power supply is a condition for the dynamic brake application, the safety analysis shall cover failures leading to absence on-board the unit of that voltage.

In case the hazard above is not controlled at the level of the rolling stock (failure of the external power supply system), the braking performance of the dynamic brake or of braking system linked to the traction system shall not be included in the performance of the emergency braking in normal mode defined in clause 4.2.4.5.2.

4.2.4.8. Braking system independent of adhesion conditions**4.2.4.8.1. General**

- (1) Brake systems able to develop a brake force applied on the rail, independent of the wheel/rail adhesion condition, are a means of providing additional braking performance when the requested performance is higher than the performance corresponding to the limit of the available wheel rail adhesion (see clause 4.2.4.6).
- (2) It is permissible to include the contribution of brakes independent of wheel/rail adhesion in the braking performance in normal mode defined in clause 4.2.4.5 for the emergency brake; in such a case, the brake system independent of adhesion condition:
- (3) Shall be commanded by the main brake system control line (see clause 4.2.4.2.1).
- (4) Shall be subject of a safety analysis covering the hazard ‘after activation of an emergency command, complete loss of the brake force independent of the wheel/rail adhesion’.

This safety analysis shall be considered in the safety analysis required by the safety requirement No 3 set out in clause 4.2.4.2.2 for the emergency brake function.

▼B

4.2.4.8.2 Magnetic track brake

- (1) Requirements on magnetic brakes specified by the CCS subsystem are referenced in clause 4.2.3.3.1 of this TSI.
- (2) A magnetic track brake is allowed to be used as an emergency brake, as mentioned in the TSI INF, clause 4.2.6.2.2.
- (3) The geometrical characteristics of the end elements of the magnet in contact with the rail shall be as specified for one of the types described in the specification referenced in Appendix J-1, index 31.
- (4) Magnetic track brake shall not be used at speed higher than 280 km/h.

4.2.4.8.3 Eddy current track brake

- (1) This clause covers only eddy current track brake developing a brake force between the rolling stock and the rail.
- (2) Requirements on eddy current track brakes specified by the CCS subsystem are referenced in clause 4.2.3.3.1 of this TSI.
- (3) The conditions for use of eddy current track brake are not harmonised (regarding their effect on rail heating and vertical force).

Therefore, requirements to be met by eddy current track brake are an open point.

- (4) Until the 'open point' is closed, the values of maximum longitudinal braking force applied to the track by the eddy current track brake specified in the clause 4.2.4.5 of the TSI HS RST 2008 and used at speed ≥ 50 km/h are deemed to be compatible with HS lines.

4.2.4.9. Brake state and fault indication

- (1) Information available to train staff shall allow the identification of degraded conditions concerning the rolling stock (brake performance lower than the performance required), for which specific operating rules apply. To that end, it shall be possible at certain phases during operation for the train staff to identify the status (applied or released or isolated) of the main (emergency and service) and parking brake systems, and the status of each part (including one or several actuators) of these systems that can be controlled and/or isolated independently.
- (2) If the parking brake always depends directly on the state of main brake system, it is not required to have an additional and specific indication for the parking brake system.
- (3) The phases that shall be considered during operation are standstill and running.
- (4) When at a standstill, train staff shall be able to check from inside and/or outside of the train:

— The continuity of the train brake control command line,

▼ B

- The availability of the braking energy supply along the train,
 - The status of the main brake and parking brake systems and the status of each part (including one or several actuators) of these systems that can be controlled and/or isolated separately (as described above in the first paragraph of this clause), excepted for dynamic brake and braking system linked to traction systems.
- (5) When running, the driver shall be able to check from the driving position in the cab:
- The status of the train brake control command line,
 - The status of the train brake energy supply,
 - The status of the dynamic brake and braking system linked to traction system where they are included in the performance of the emergency braking in normal mode,
 - The status applied or released of at least one part (actuator) of the main brake system which is controlled independently (e.g. a part which is installed on the vehicle fitted with an active cab).
- (6) The function providing the information described above to the train staff is a function essential to safety, as it is used for the train staff to evaluate the braking performance of the train.

Where local information is provided by indicators, the use of harmonised indicators ensures the required safety level.

Where a centralised control system allowing the train staff to perform all checks from one location (i.e. inside the drivers cab) is provided, it shall be subject to a reliability study, considering the failure mode of components, redundancies, periodic checks and other provisions; based on this study, operating conditions of the centralised control system shall be defined and provided in the operating documentation described in clause 4.2.12.4.

- (7) Applicability to units intended for general operation:

Only functionalities that are relevant to the design characteristics of the unit (e.g. presence of a cab,...) shall be considered.

The signals transmission required (if any) between the unit and the other coupled unit(s) in a train for the information regarding the brake system to be available at train level shall be documented, taking into account functional aspects.

▼ B

This TSI does not impose any technical solution regarding physical interfaces between units.

4.2.4.10. Brake requirements for rescue purposes

- (1) All brakes (emergency, service, parking) shall be fitted with devices allowing their release and isolation. These devices shall be accessible and functional whether the train or vehicle is: powered, non-powered or immobilised without any available energy on board.
- (2) For units intended to be operated on other track gauge systems than 1 520 mm system, it shall be possible, following a failure during operation, to rescue a train with no energy available on board by a recovery power unit equipped with a pneumatic brake system compatible with the UIC brake system (brake pipe as braking control command line).

Note: see clause 4.2.2.4 of this TSI for mechanical and pneumatical interfaces of the recovery unit.

- (3) During the rescue, it shall be possible to have a part of the brake system of the rescued train controlled by means of an interface device; in order to meet this requirement, it is allowed to rely on low voltage provided by a battery to supply control circuits on the rescued train.
- (4) The braking performance developed by the rescued train in this particular operating mode shall be evaluated by a calculation, but is not required to be the same as the braking performance described in clause 4.2.4.5.2. The calculated braking performance and rescue operating conditions shall be part of the technical documentation described in clause 4.2.12.
- (5) This requirement does not apply to units which are operated in a train formation of less than 200 tons (load condition 'design mass in working order').

4.2.5. *Passenger-related items*

For information purposes only, the following non-exhaustive list gives an overview of the basic parameters covered by the TSI PRM, which are applicable to units which are intended to carry passengers:

- seats, including priority seats
- wheelchair spaces
- exterior doors, including dimensions, passenger interface for controls
- interior doors, including dimensions, passenger interface for controls
- toilets
- clearways
- lighting

▼ B

- customer information
- floor height changes
- handrails
- wheelchair-accessible sleeping accommodation
- step position for vehicle access and egress, including steps and boarding aids.

Additional requirements are specified below in this clause.

4.2.5.1. Sanitary systems

- (1) If a water tap is provided in a unit and unless the water is provided from the tap in accordance with Council Directive 98/83/EC ⁽¹⁾, a visual sign shall clearly indicate that the water provided at the tap is not drinkable.
- (2) Sanitary systems (toilets, washrooms, bar/restaurant facilities) where fitted shall not allow the release of any material that may be detrimental to the health of people or to the environment. Released materials (i.e. treated water; water with soap directly released from washrooms excluded) shall be conformant to the following Directives:
 - The bacterial content of water discharged from sanitary systems shall not at any time exceed the bacterial content value for Intestinal enterococci and *Escherichia coli* bacteria specified as 'good' for Inland waters in Directive 2006/7/EC of the European Parliament and of the Council ⁽²⁾ concerning the management of bathing water quality.
 - The treatment processes shall not introduce substances that are identified in Annex I of Directive 2006/11/EC of the European Parliament and of the Council ⁽³⁾ on pollution caused by certain dangerous substances discharged into the aquatic environment of the Union.
- (3) To limit the dispersion of released liquid on the trackside, uncontrolled discharge from any source shall take place downwards only, under the body frame of the vehicle in a distance not greater than 0,7 metres from the longitudinal centre line of the vehicle.
- (4) The following shall be provided in the technical documentation described in clause 4.2.12:
 - The presence and type of toilets in a unit,
 - The characteristics of the flushing medium, if it is not clean water,
 - The nature of the treatment system for released water and the standards against which conformity has been assessed.

⁽¹⁾ Council Directive 98/83/EC of 3 November 1998 on the quality of water intended for human consumption (OJ L 330, 5.12.1998, p. 32).

⁽²⁾ Directive 2006/7/EC of the European Parliament and of the Council of 15 February 2006 concerning the management of bathing water quality and repealing Directive 76/160/EEC (OJ L 64, 4.3.2006, p. 37).

⁽³⁾ 32006L0011: Directive 2006/11/EC of the European Parliament and of the Council of 15 February 2006 on pollution caused by certain dangerous substances discharged into the aquatic environment of the Community (OJ L 64, 4.3.2006, p. 52).

▼B

4.2.5.2. Audible communication system

- (1) This clause applies to all units designed to carry passengers and units designed to haul passenger trains.
- (2) Trains shall be equipped as a minimum with a means of audible communication:
 - for the train crew to address the passengers in a train
 - for internal communication between the train crew and in particular between the driver and staff in the passenger area (if any).
- (3) The equipment shall be able to remain on standby independently of the main energy source for at least three hours. During the standby time the equipment shall be able to actually function at random intervals and periods during an accumulated time of 30 minutes.
- (4) The communication system shall be designed in such a manner that it continues to operate at least half (distributed throughout the train) of its loudspeakers in the event of a failure in one of its transmission elements or, as an alternative, another means shall be available to inform the passengers in the event of a failure.
- (5) Provisions for passengers to contact train crew are prescribed in clause 4.2.5.3 (passenger alarm) and in clause 4.2.5.4 (communication devices for passengers)
- (6) Applicability to units intended for general operation:

Only functionalities that are relevant to the design characteristics of the unit (e.g. presence of a cab, of a crew interface system,...) shall be considered.

The signals transmission required between the unit and the other coupled unit(s) in a train for the communication system to be available at train level shall be implemented and documented, taking into account functional aspects.

This TSI does not impose any technical solution regarding physical interfaces between units.

4.2.5.3. Passenger alarm

4.2.5.3.1 General

- (1) This clause is applicable to all units designed to carry passengers and units designed to haul passenger trains.
- (2) The passenger alarm function gives to anyone in the train the opportunity to advise the driver of a potential danger, and has consequences at operating level when activated (e.g. braking initiation in absence of reaction from the driver); it is a safety related function, for which the requirements, including safety aspects, are set out in this clause.

▼ B

4.2.5.3.2 Requirements for information interfaces

- (1) With the exception of toilets and gangways, each compartment, each entrance vestibule and all other separated areas intended for passengers shall be equipped with at least one clearly visible and indicated alarm device to inform the driver of a potential danger.
- (2) The alarm device shall be designed so that once activated it cannot be cancelled by passengers.
- (3) At the triggering of the passenger alarm, both visual and acoustic signs shall indicate to the driver that one or more passenger alarms have been activated.
- (4) A device in the cab shall allow the driver to acknowledge his awareness of the alarm. The driver's acknowledgement shall be perceivable at the place where the passenger alarm was triggered and shall stop the acoustic signal in the cab.
- (5) On the driver's initiative, the system shall allow a communication link to be established between the driver's cab and the place where the alarm(s) was/were triggered for units designed for operation without staff on-board (other than driver). For units designed for operation with staff on-board (other than driver), it is permitted to have this communication link established between the driver's cab and the staff on-board.

The system shall allow the driver to cancel this communication link on his initiative.

- (6) A device shall enable the crew to reset the passenger alarm.

4.2.5.3.3 Requirements for activation of the brake by the passenger alarm

- (1) When the train is stopped at a platform or departing from a platform, activation of a passenger alarm shall lead to a direct application of the service brake or the emergency brake, resulting in a complete stop. In this case, only after the train has come to a complete stop, a system shall allow the driver to cancel any automatic braking action initiated by the passenger alarm;
- (2) In other situations, 10 +/-1 seconds after activation of the (first) passenger alarm, at least an automatic service brake shall be initiated unless the passenger alarm is acknowledged by the driver within this time. The system shall allow the driver to override at any time an automatic braking action initiated by the passenger alarm.

4.2.5.3.4 Criteria for a train departing from a platform

- (1) A train is deemed to be departing from a platform during the period of time elapsing between the moment when door status is changed from 'released' to 'closed and locked' and the moment when the train has partly left the platform.

▼B

- (2) This moment shall be detected on-board (function allowing physical detection of the platform or based on speed or distance criteria, or any alternative criteria).

- (3) For units intended to operate on lines that are fitted with the ETCS track side system for control-command and signalling (including 'passenger door' information as described in Annex A Index 7 of TSI CCS), this on-board device shall be able to receive from the ETCS system the information related to platform.

4.2.5.3.5 Safety requirements

- (1) For the scenario 'failure in the passenger alarm system leading to the impossibility for a passenger to initiate the activation of brake in order to stop the train when train departs from a platform', it shall be demonstrated that the risk is controlled to an acceptable level considering that the functional failure has typical credible potential to lead directly to 'single fatality and/or severe injury'.

- (2) For the scenario 'failure in the passenger alarm system leading to no information given to the driver in case of activation of a passenger alarm', it shall be demonstrated that the risk is controlled to an acceptable level considering that the functional failure has typical credible potential to lead directly to 'single fatality and/or severe injury'.

- (3) The demonstration of conformity (conformity assessment procedure) is described in clause 6.2.3.5 of this TSI.

4.2.5.3.6 Degraded mode

- (1) Units fitted with a driver's cab shall be fitted with a device which allows authorised staff to isolate the passenger alarm system.

- (2) If the passenger alarm system is not functioning, either after intentional isolation by staff, due to a technical failure, or by coupling the unit with a non-compatible unit, this shall be permanently indicated to the driver in the active driver's cab, and application of the passenger alarm shall result in a direct application of brakes.

- (3) A train with an isolated passenger alarm system does not meet the minimum requirements for safety and interoperability as defined in this TSI and shall therefore be regarded to as being in degraded mode.

4.2.5.3.7 Applicability to units intended for general operation

- (1) Only functionalities that are relevant to the design characteristics of the unit (e.g. presence of a cab, of a crew interface system,...) shall be considered.

▼ B

- (2) The signals transmission required between the unit and the other coupled unit(s) in a train for the passenger alarm system to be available at train level shall be implemented and documented, taking into account functional aspects described above in this clause.
- (3) This TSI does not impose any technical solution regarding physical interfaces between units.

4.2.5.4. Communication devices for passengers

- (1) This clause applies to all units designed to carry passengers and units designed to haul passenger trains.
- (2) Units designed for operation without staff on-board (other than driver) shall be equipped with a 'communication device' for passengers to inform a person who can take appropriate action.
- (3) The requirements to the location of the 'communication device' are the ones applicable for the passenger alarm as defined in clause 4.2.5.3 'Passenger alarm: functional requirements'.
- (4) The system shall allow the communication link to be requested on the initiative of the passenger. The system shall allow the person receiving the communication (e.g. driver) to cancel this communication link at his initiative.
- (5) The 'communication device' interface to passengers shall be indicated by a harmonised sign, shall include visual and tactile symbols and shall emit a visual and audible indication that it has been operated. These elements shall be in accordance with the PRM TSI.
- (6) Applicability to units intended for general operation:

Only functionalities that are relevant to the design characteristics of the unit (e.g. presence of a cab, of a crew interface system, etc.) shall be considered.

The signals transmission required between the unit and the other coupled unit(s) in a train for the communication system to be available at train level shall be implemented and documented, taking into account functional aspects.

This TSI does not impose any technical solution regarding physical interfaces between units.

4.2.5.5. Exterior doors: passenger access to and egress from Rolling Stock

4.2.5.5.1. General

- (1) This clause applies to all units designed to carry passengers and units designed to haul passenger trains.

▼B

- (2) Doors intended for staff and freight are dealt with in clauses 4.2.2.8 and 4.2.9.1.2 of this TSI.
- (3) The control of external passenger access doors is a function essential to safety; the functional and safety requirements expressed in this clause are necessary to ensure the safety level required.

4.2.5.5.2 Terminology used

- (1) In the context of this clause a 'door' is an external passenger access door (with one or more leaves), intended primarily for passengers to enter and leave the unit.
- (2) A 'locked door' is a door held closed by a physical door locking device
- (3) A 'door locked out of service' is a door immobilised in a closed position by a manually operated mechanical locking device.
- (4) A door 'released' is a door that is able to be opened by operating the local or, central door control, (where the latter is available).
- (5) For the purpose of this clause, a train is assumed to be at a standstill when the speed has decreased to 3 km/h or less.
- (6) For the purpose of this clause, 'train crew' means one member of the on-board staff in charge of the checks related to the door system; it may be the driver or another member of the on-board staff.

4.2.5.5.3. Door closing and locking

- (1) The door control device shall allow the train crew to close and lock all the doors before the train departs.
- (2) Where a movable step has to be retracted, the closing sequence shall include the movement of the step to the retracted position.
- (3) When the centralised door closing and locking is activated from a local control, adjacent to a door, it is permissible for this door to remain open when the other doors close and lock. The door control system shall allow the staff to close and lock this door subsequently before departure.
- (4) The doors shall be kept closed and locked until they are released in accordance with clause 4.2.5.5.6 'Door opening'. In the event of loss of power to the door controls, the doors shall be kept locked by the locking mechanism.

Note: see clause 4.2.2.3.2 of TSI PRM for alert signal when closing a door.

▼ B**Door obstacle detection:**

- (5) External passenger access doors shall incorporate devices that detect if they close on an obstacle (e.g. a passenger). Where an obstacle is detected the doors shall automatically stop, and remain free for a limited period of time or reopen. The sensitivity of the system shall be such as to detect an obstacle according to the specification referenced in Appendix J-1, index 32, clause 5.2.1.4.1, with a maximum force on the obstacle according to the specification referenced in Appendix J-1, index 32, clause 5.2.1.4.2.1.

4.2.5.5.4 Locking a door out of service

- (1) A manually operated mechanical device shall be provided to enable (the train crew or maintenance staff) to lock a door out of service.
- (2) The locking out of service device shall:
 - Isolate the door from any opening command
 - Lock the door mechanically in the closed position
 - Indicate the status of the isolation device
 - Permit the door to be by-passed by the 'door-closed proving system'

4.2.5.5.5 Information available to the train crew

- (1) An appropriate 'doors-closed proving system' shall allow the train crew to check at any moment whether or not all the doors are closed and locked.
- (2) If one or more doors are not locked, this shall be continuously indicated to the train crew.
- (3) An Indication shall be provided to the train crew of any fault of a door closing and/or locking operation.
- (4) Audible and visual alarm signal shall indicate to the train crew an emergency opening of one or more doors.
- (5) A 'door locked out of service' is permitted to be by-passed by the 'doors-closed proving system'.

4.2.5.5.6 Door opening

- (1) A train shall be provided with door release controls, which allow the train crew or an automatic device associated with the stop at a platform, to control the release of doors separately on each side, allowing them to be opened by passengers or, if available, by a central opening command when the train is at a standstill.
- (2) For units intended to operate on lines that are fitted with the ETCS track side system for control-command and signalling (including 'passenger door' information as described in Annex A, Index 7 of TSI CCS), this door release control system shall be able to receive from the ETCS system the information related to platform.

▼ B

- (3) At each door, local opening controls or opening devices shall be accessible for passengers from both the outside and the inside of the vehicle.
- (4) Where a movable step has to be deployed, the opening sequence shall include the movement of the step to the deployed position.

Note: see clause 4.2.2.4.2 of TSI PRM for alert signal when opening a door.

4.2.5.5.7 Door-traction interlock

- (1) Traction power shall be applied only when all doors are closed and locked. This shall be ensured through an automatic door-traction interlock system. The door-traction interlock system shall prevent traction power being applied when not all of the doors are closed and locked.
- (2) The traction interlock system shall be provided with a manual override, intended to be activated by the driver in exceptional situations, to apply traction even when not all of the doors are closed and locked.

4.2.5.5.8 Safety requirements for clauses 4.2.5.5.2 to 4.2.5.5.7

- (1) For the scenario one door is unlocked (with train crew not correctly informed of this door status) or released or opened in inappropriate areas (e.g. wrong side of train) or situations (e.g. train running), it shall be demonstrated that the risk is controlled to an acceptable level, considering that the functional failure has typical credible potential to lead directly to:
 - ‘single fatality and/or severe injury’ for units in which passengers are not supposed to stay in standing position in the door area (long distance), or to
 - ‘single fatality and/or severe injury’ for units in which some passengers stay in standing position in the door area in normal operation.
- (2) For the scenario several doors are unlocked (with train crew not correctly informed of this door status) or released or opened in inappropriate areas (e.g. wrong side of the train) or situations (e.g. train running), it shall be demonstrated that the risk is controlled to an acceptable level, considering that the functional failure has typical credible direct potential to lead to:
 - ‘fatality and/or severe injury’ for units in which passengers are not supposed to stay in standing position in the door area (long distance), or to
 - ‘fatalities and/or severe injuries’ for units in which some passengers stay in standing position in the door area in normal operation.

▼B

- (3) The demonstration of conformity (conformity assessment procedure) is described in clause 6.2.3.5 of this TSI.

4.2.5.5.9 Door emergency opening

Internal emergency opening:

- (1) Each door shall be provided with an individual internal emergency-opening device accessible to passengers, that shall allow the door to open; this device shall be active when the speed is below 10 km/h.
- (2) It is allowed to have this device active at any speed (independent of any speed signal); in such a case, this device shall be operated after a succession of at least two actions.
- (3) This device is not required to have an effect on 'a door locked out of service'. In such a case the door may be unlocked first.

Safety requirement:

- (4) For the scenario 'failure in the internal emergency opening system of two adjacent doors along a through route (as defined in clause 4.2.10.5 of this TSI), the emergency opening system of other doors remaining available', it shall be demonstrated that the risk is controlled to an acceptable level, considering that the functional failure has typical credible potential to lead directly to 'single fatality and/or severe injury'.

The demonstration of compliance (conformity assessment procedure) is described in clause 6.2.3.5 of this TSI.

External emergency opening:

- (5) Each door shall be provided with an individual external emergency-opening device, accessible to rescue staff, to allow that door to be opened for emergency reasons. This device is not required to have an effect on 'a door locked out of service'. In such a case the door shall be unlocked first.

Manual force to open the door:

- (6) For manual opening of the door, the force required to be exerted by a person shall be according to the specification referenced in Appendix J-1, index 33.

4.2.5.5.10 Applicability to units intended for general operation

- (1) Only functionalities that are relevant to the design characteristics of the unit (e.g. presence of a cab, of a crew interface system for door control, etc.) shall be considered.
- (2) The signals transmission required between the unit and the other coupled unit(s) in a train for the door system to be available at train level shall be implemented and documented, taking into account functional aspects.

▼B

- (3) This TSI does not impose any technical solution regarding physical interfaces between units.

4.2.5.6. Exterior door system construction

- (1) If a unit is fitted with a door intended to be used by passengers to access or egress the train, the following provisions apply:
 - (2) Doors shall be fitted with transparent windows to allow passengers to identify the presence of a platform.
 - (3) The outside surface of passenger units shall be designed in such a way that they do not give the possibility for a person to ‘train surf’ when the doors are closed and locked.
 - (4) As a measure to prevent ‘train surfing’, handholds on the outside surface of the door system shall be avoided or designed so that they cannot be gripped when the doors are closed.
 - (5) Handrails and handholds shall be fixed so that they can withstand the forces exerted on them during operation.

4.2.5.7. Inter-unit doors

- (1) This clause is applicable to all units designed to carry passengers.
- (2) Where a unit is equipped with inter-unit doors at the end of coaches or at unit-ends, they shall be fitted with a device that allows them to be locked (e.g. where a door is not connected by a gangway for use of passengers to an adjacent coach or unit, etc.).

4.2.5.8. Internal air quality

- (1) The quantity and quality of air provided inside the area of vehicles occupied by passengers and/or staff shall be such that no risk is developed to the health of passengers or staff additional to those resulting from the external ambient air quality. This is achieved by complying with the requirements set up below.

A ventilation system shall maintain an acceptable interior CO₂ level under operational conditions.

- (2) The CO₂ level shall not exceed 5 000 ppm in all operating conditions, excepted in the 2 cases below:

— In case of interruption of the ventilation, due to an interruption of the main power supply or to a breakdown of the system, an emergency provision shall ensure the supply of outside air into all passenger and staff areas.

If this emergency provision is ensured through battery supplied forced ventilation, the duration in which the CO₂ level will remain below 10 000 ppm shall be defined, assuming a passenger load derived from the load condition ‘design mass under normal payload’.

▼B

The conformity assessment procedure is defined in clause 6.2.3.12.

This duration shall not be less than 30 minutes.

The duration shall be recorded in the technical documentation defined in clause 4.2.12 of this TSI.

- In case of switch off or closing of all means of external ventilation, or switch off of air conditioning system, in order to prevent passengers being exposed to environmental fumes that may be present, especially in tunnels, and in the event of a fire, as described in clause 4.2.10.4.2.

4.2.5.9. Body side windows

- (1) Where body side windows can be opened by passengers and cannot be locked by the train staff, the size of the opening shall be limited to such dimensions that it is not possible to pass a ball shaped object with 10cm diameter through it.

4.2.6. *Environmental conditions and aerodynamic effects*

4.2.6.1. Environmental conditions — general

- (1) Environmental conditions are physical, chemical or biological conditions external to a product and to which it is subjected to.
- (2) The environmental conditions to which rolling stock is subjected to influence the design of rolling stock, as well as this of its constituents.
- (3) The environmental parameters are described in the clauses below; for each environmental parameter, a nominal range is defined, which is the most commonly encountered in Europe, and is the basis for interoperable rolling stock.
- (4) For certain environmental parameters, ranges other than the nominal one are defined; in that case, a range shall be selected for the design of the rolling stock.

For the functions identified in the clauses below, design and/or testing provisions taken to ensure that the rolling stock is meeting the TSI requirements in this range shall be described in the technical documentation.

- (5) The selected range(s) shall be recorded in the technical documentation described in clause 4.2.12 of this TSI, as a characteristic of the rolling stock.
- (6) Depending on the ranges selected, and on provisions taken (described in the technical documentation), relevant operating rules could be necessary to ensure the technical compatibility between the rolling stock and environmental conditions that can be met on parts of the network.

In particular, operating rules are necessary when rolling stock designed for the nominal range is operated on a particular line where the nominal range is exceeded at certain periods of the year.

▼B

- (7) The ranges, if different than the nominal one, to be selected to avoid any restrictive operating rule(s) linked to a geographical area and climatic conditions, are specified by the Member States and are listed in the clause 7.4 of this TSI.

4.2.6.1.1 Temperature

- (1) Rolling stock shall meet the requirements of this TSI within one (or several) of the temperature ranges T1 (– 25 °C to + 40 °C; nominal), or T2 (– 40 °C to + 35 °C) or T3 (– 25 °C to + 45 °C) as defined in the specification referenced in Appendix J-1, index 34
- (2) The selected temperature range (s) shall be recorded in the technical documentation described in clause 4.2.12 of this TSI.
- (3) The temperature to consider for design purpose of rolling stock constituents shall take into account their integration in the rolling stock.

4.2.6.1.2 Snow, ice and hail

- (1) Rolling stock shall meet the requirements of this TSI when subject to snow, ice and hail conditions as defined in the specification referenced in Appendix J-1, index 35, which correspond to the nominal conditions (range).
- (2) The effect of snow, ice and hail to consider for design purpose of rolling stock constituents shall take into account their integration in the rolling stock.
- (3) Where more severe 'snow, ice and hail' conditions are selected, rolling stock and the parts of the subsystem shall then be designed to meet TSI requirements considering the following scenarios:
- Snowdrift (light snow with low water equivalent content), covering the track up to 80 cm continuously above top rail level.
 - Powder snow, snowfall of large quantities of light snow with low water equivalent content.
 - Temperature gradient, temperature and humidity variation during one single run causing ice build-ups on the rolling stock.
 - Combined effect with low temperature according to the temperature zone chosen as defined in clause 4.2.6.1.1.
- (4) In relation with clause 4.2.6.1.1 (climatic zone T2) and with the present clause 4.2.6.1.2 (severe conditions for snow, ice and hail) of this TSI, the provisions taken to meet TSI requirements in these severe conditions shall be identified and verified, in particular design and/or testing provisions that are required for the following TSI requirements:
- Obstacle deflector as defined in this TSI clause 4.2.2.5: additionally, capability to remove snow in front of the train.

▼B

Snow shall be considered as an obstacle to be removed by the obstacle deflector; the following requirements are defined in clause 4.2.2.5 (by reference to the specification referenced in Appendix J-1, index 36):

‘The obstacle deflector needs to be of sufficient size to sweep obstacles clear of the path of the bogie. It shall be a continuous structure and shall be designed so as not to deflect objects upwards or downwards. Under normal operating conditions, the lower edge of the obstacle deflector shall be as close to the track as the vehicle movements and gauge line will permit.

In plan view the deflector should approximate to a “V” profile with an included angle of not more than 160°. It can be designed with a compatible geometry to function also as a snow plough’

The forces specified in clause 4.2.2.5 of this TSI are deemed to be sufficient in order to remove the snow.

- Running gear as defined in the TSI clause 4.2.3.5: considering snow and ice build-up and possible consequence on running stability and brake function.
- Brake function and brake power supply as defined in the TSI clause 4.2.4.
- Signalling the presence of the train to others as defined in the TSI clause 4.2.7.3.
- Providing a view ahead as defined in the TSI clause 4.2.7.3.1.1 (head lights) and 4.2.9.1.3.1 (front visibility), with windscreen's equipment as defined in clause 4.2.9.2 functioning.
- Providing the driver with acceptable climate for working as defined in the TSI clause 4.2.9.1.7.

- (5) The selected range for ‘snow, ice and hail’ (nominal or severe) and provision adopted shall be documented in the technical documentation described in clause 4.2.12.2 of this TSI.

4.2.6.2. Aerodynamic effects

- (1) The requirements in this clause apply to all rolling stock except those designed to be operated on the 1 520 mm or 1 524 mm or 1 600 mm or 1 668 mm track gauge systems for which the corresponding requirements are an open point.
- (2) The passing of a train causes an unsteady airflow with varying pressures and flow velocities. These pressure and flow velocity transients have an effect on persons, objects and buildings at the trackside; they have also an effect on the rolling stock (e.g. aerodynamic load on vehicle structure, buffeting of equipment), and are to be taken into account in the design of rolling stock.

▼B

- (3) The combined effect of train speed and air speed causes an aerodynamic rolling moment that can affect the stability of rolling stock.

4.2.6.2.1 Slipstream effects on passengers on platform and on workers trackside

- (1) Units of maximum design speed $v_{tr} > 160$ km/h, running in the open air at a reference speed specified in Table 4, shall not cause the air speed to exceed the value $u_{2\sigma}$ as indicated in the Table 4 as measured at a height of 0,2 m and 1,4 m above top of rail at a distance of 3,0 m from the track centre, during the passage of the unit.

Table 4

Limit criteria

Maximum design speed $v_{tr,max}$ (km/h)	Measurement performed at height above the top of rail	Trackside maximum permissible air speed, (limit values for $u_{2\sigma}$ (m/s))	Reference speed $v_{tr,ref}$ (kxm/h)
$160 < v_{tr,max} < 250$	0,2 m	20	Maximum design speed
	1,4 m	15,5	200 km/h or the maximum design speed, whichever is lower
$250 \leq v_{tr,max}$	0,2 m	22	300 km/h or the maximum design speed, whichever is lower
	1,4 m	15,5	200 km/h

- (2) The formation to be tested is specified below for different types of rolling stock:

— Unit assessed in fixed formation

The full length of the fixed formation.

In case of multiple unit operation at least two units coupled together shall be tested.

— Units assessed in predefined formation

Train formation including the end vehicle and intermediate vehicles in a rake consisting of at least 100 m or the maximum predefined length if shorter than 100 m.

— Unit assessed for use in general operation (train formation not defined at design stage):

— the unit shall be tested in a train formation consisting of a rake of at least 100 m of intermediate coaches;

— in the case of a locomotive or driving cab this vehicle shall be placed in the first and in the last position of the train formation;

▼ B

- in the case of coaches (passenger carriages) the train formation shall include as a minimum a coach formed by the type of unit under assessment running in first and last positions of the rake of intermediate coaches.

Note: for coaches a conformity assessment is required only in case of new design that has an impact on the slipstream effect.

- (3) The conformity assessment procedure is described in clause 6.2.3.13 of this TSI.

4.2.6.2.2 Head pressure pulse

- (1) The passing of two trains generates an aerodynamic load on each of the two trains. The requirement on head pressure pulse in open air allows defining a limit aerodynamic load induced by the rolling stock in open air assuming a track centre distance for the track where the train is intended to be operated.

The track centre distance depends on the speed and the gauge of the line; minimum values of track centre distance depending on speed and gauge are defined as per the INF TSI.

- (2) Units with a maximum design speed higher than 160 km/h and lower than 250 km/h, running in the open air at their maximum speed shall not cause the maximum peak-to-peak pressure of changes to exceed a value of 800 Pa as assessed over the range of height between 1,5 m and 3,0 m above the top of rail, and at a distance of 2,5 m from the track centre, during the passage of the head.
- (3) Units with a maximum design speed higher or equal to 250 km/h running in the open air at the given reference speed 250 km/h shall not cause the maximum peak-to-peak pressure of changes to exceed a value of 800 Pa as assessed over the range of height between 1,5 m and 3,0 m above the top of rail, and at a distance of 2,5 m from the track centre, during the passage of the head.
- (4) The formation to be verified by a test is specified below for different types of rolling stock:

— Unit assessed in fixed or predefined formation:

- A single unit of the fixed formation or any configuration of the predefined formation.

— Unit assessed for use in general operation (train formation not defined at design stage):

- Unit fitted with a drivers cab shall be assessed alone.

— Other units: Requirement not applicable.

- (5) The conformity assessment procedure is described in clause 6.2.3.14 of this TSI.

▼B

4.2.6.2.3 Maximum pressure variations in tunnels

- (1) Units of maximum design speed higher than or equal to 200 km/h shall be aerodynamically designed so that for a given combination (reference case) of train speed and tunnel cross section in case of a solo run in a simple, non-inclined tube-like tunnel (without any shafts etc.) a requirement for the characteristic pressure variation shall be met. The requirements are given in the Table 5.

Table 5

Requirements for units in a solo-run in a non-inclined tube-like tunnel

	Reference case		Criteria for the reference case		
	v_{tr}	A_{tu}	Δp_N	$\Delta p_N + \Delta p_{Fr}$	$\Delta p_N + \Delta p_{Fr} + \Delta p_T$
< 250 km/h	200 km/h	53,6 m ²	≤ 1 750 Pa	≤ 3 000 Pa	≤ 3 700 Pa
≥ 250 km/h	250 km/h	63,0 m ²	≤ 1 600 Pa	≤ 3 000 Pa	≤ 4 100 Pa

Where v_{tr} is the train speed and A_{tu} is the tunnel cross sectional area.

- (2) The formation to be verified by a test is specified below for different types of rolling stock:

— Unit assessed in fixed or predefined formation: assessment shall be made with the maximum length of the train (including multiple operation of trainsets).

— Unit assessed for general operation (train formation not defined at design stage) and fitted with a driver's cab: two arbitrary train compositions of minimum length 150 m; one with the unit in leading position and one with the unit at the end.

— Other units (coaches for general operation): on the basis of one train formation of at least 400 m.

- (3) The conformity assessment procedure, including definition of parameters mentioned above is described in clause 6.2.3.15 of this TSI.

4.2.6.2.4 Cross wind

- (1) This requirement applies to units of maximum design speed higher than 140 km/h.
- (2) For units of maximum design speed higher than 140 km/h and lower than 250 km/h the characteristic wind curve (CWC) of the most sensitive vehicle shall be determined in accordance with the specification referenced in Appendix J-1, index 37 and subsequently recorded in the technical file as per clause 4.2.12.

▼B

(3) For units of maximum design speed equal to or higher than 250 km/h the crosswind effects shall be evaluated according to one of the following methods:

(a) determined and complying with the specification of the HS RST TSI 2008 clause 4.2.6.3,

or

(b) determined by the assessment method of the specification referenced in Appendix J-1, index 37. The resulting characteristic wind curve of the most sensitive vehicle of the unit under assessment shall be recorded in the technical documentation as per clause 4.2.12.

4.2.6.2.5 Aerodynamic effect on ballasted tracks

(1) This requirement applies to units of maximum design speed higher than or equal to 190 km/h.

(2) The requirement on the aerodynamic effect of trains on ballasted tracks, in order to limit risks induced by the projection of ballast (ballast pick up), is an open point.

4.2.7. *External lights & visible and audible warning devices*

4.2.7.1. External lights

(1) The colour green shall not be used for external light or illumination; this requirement is made to prevent any confusion with fixed signals.

(2) This requirement is not applicable to lights of intensity not higher than 100 cd/m² that are included in push buttons for the command of passenger doors (not continuously lit).

4.2.7.1.1. Head lights

(1) This clause applies to units fitted with a driver's cab.

(2) Two white headlamps shall be provided at the front end of the train in order to give visibility for the train driver.

(3) These head lamps shall be located:

— at the same height above the rail level, with their centres between 1 500 and 2 000 mm above the rail level,

— symmetrically compared to the centre-line of rails, and with a distance between their centres not less than 1 000 mm.

(4) The colour of head lamps shall be in accordance with the values specified in the specification referenced in Appendix J-1, index 38, clause 5.3.3, Table 1.

(5) Headlamps shall provide 2 luminous intensity levels: 'dimmed headlamp' and 'full-beam headlamp'.

For 'dimmed headlamp', the luminous intensity of headlamps measured along the optical axis of the head lamp shall be in accordance with the values specified in the specification referenced in Appendix J-1, index 38, clause 5.3.4, table 2, first line.

▼B

For ‘full-beam headlamp’, the minimum luminous intensity of headlamps measured along the optical axis of the lamp shall be in accordance with the values specified in the specification referenced in Appendix J-1, index 38, clause 5.3.4, Table 2, first line.

- (6) The installation of head lamps on the unit shall provide a means of alignment adjustment of their optical axis when installed on the unit according to the specification referenced in Appendix J-1, index 38, clause 5.3.5, to be used during maintenance activities.
- (7) Additional head lamps may be provided (e.g. upper head lamps). These additional head lamps shall fulfil the requirement on the colour of head lamps specified above in this clause.

Note: additional head lamps are not mandatory; their use at operational level may be subject to restrictions.

4.2.7.1.2 Marker lights

- (1) This clause applies to units fitted with a driver's cab.
- (2) Three white marker lamps shall be provided at the front end of the train in order to make the train visible.
- (3) Two lower marker lamps shall be located:
 - at the same height above the rail level, with their centres between 1 500 and 2 000 mm above the rail level,
 - symmetrically compared to the centre-line of rails, and with a distance between their centres not less than 1 000 mm.
- (4) The third marker lamp shall be located centrally above the two lower lamps, with a vertical separation between their centres equal to or greater than 600 mm.
- (5) It is permitted to use the same component for both head lights and marker lights.
- (6) The colour of marker lamps shall be in accordance with the values specified in the specification referenced in Appendix J-1, index 39, clause 5.4.3.1, Table 4.
- (7) The spectral radiation distribution of light from the marker lamps shall be in accordance with the values specified in the specification referenced in Appendix J-1, index 39, clause 5.4.3.2.
- (8) The luminous intensity of marker lamps shall be in accordance with the specification referenced in Appendix J-1, index 39, clause 5.4.4, Table 6.

4.2.7.1.3 Tail lights

- (1) Two red tail lamps shall be provided at the rear end of units intended to be operated at the rear end of the train in order to make the train visible.

▼B

- (2) For units without driver's cab assessed for general operation, the lamps may be portable lamps; in that case, the type of portable lamp to be used shall be in accordance with the Appendix E of the 'freight wagons' TSI; the function shall be verified by design examination and type test at component level (interoperability constituent 'portable tail lamp'), but it is not required to provide the portable lamps.
- (3) The tail lamps shall be located:
 - at the same height above the rail level, with their centres between 1 500 and 2 000 mm above the rail level,
 - symmetrically compared to the centre-line of rails, and with a distance between their centres not less than 1 000 mm.
- (4) The colour of tail lamps shall be in accordance with the specification referenced in Appendix J-1, index 40, clause 5.5.3, Table 7.
- (5) The luminous intensity of tail lamps shall be in accordance with the specification referenced in Appendix J-1, index 40, clause 5.5.4, Table 8.

4.2.7.1.4 Lamp controls

- (1) This clause applies to units fitted with a driver's cab.
- (2) It shall be possible for the driver to control:
 - the head, marker lamps of the unit from the normal driving position;
 - the tail lamps of the unit from the cab.

This control may use independent command or combination of commands.

Note: where it is intended to use lights to inform of an emergency situation (operating rule, see TSI OPE), this should be done only by means of head lamps in flashing/blinking mode.

4.2.7.2. Horn (audible warning device)

4.2.7.2.1 General

- (1) This clause applies to units fitted with a driving cab.
- (2) Trains shall be fitted with warning horns in order to make the train audible.
- (3) The notes of the audible warning horns are intended to be recognisable as being from a train and not be similar to warning devices used in road transport or as factory or other common warning device. The operation of the warning horns shall emit at least one of the following separate warning sounds below:
 - Sounding 1: the fundamental frequency of the separately sounded note shall be 660 Hz \pm 30 Hz (high note).

▼ B

— Sounding 2: the fundamental frequency of the separately sounded note shall be $370 \text{ Hz} \pm 20 \text{ Hz}$ (low note).

- (4) In case additional warning sounds to one of the above (separate or combined) are provided on a voluntary basis, their sound pressure level shall not be higher than values specified below in the clause 4.2.7.2.2.

Note: their use at operational level may be subject to restrictions.

4.2.7.2.2 Warning horn sound pressure levels

- (1) The C weighted sound pressure level produced by each horn sounded separately (or in a group if designed to sound simultaneously as a chord) when integrated on the unit shall be as defined in the specification referenced in Appendix J-1, index 41.
- (2) The conformity assessment procedure is specified in clause 6.2.3.17.

4.2.7.2.3 Protection

- (1) Warning horns and their control systems shall be designed or protected, so far as is practicable, to maintain their function when impacted by airborne objects such as debris, dust, snow, hail or birds.

4.2.7.2.4 Horn control

- (1) It shall be possible for the driver to sound the audible warning device from all driving positions specified in clause 4.2.9 of this TSI.

4.2.8. *Traction and electrical equipment*

4.2.8.1. Traction performance

4.2.8.1.1. General

- (1) The purpose of the train traction system is to ensure that the train is able to be operated at various speeds up to its maximum service speed. The primary factors that influence traction performance are traction power, train composition and mass, adhesion, track gradient and train running resistance.
- (2) Unit performance for units fitted with traction equipment, and operated in various train formations shall be defined so that the overall traction performance of the train can be derived.
- (3) The traction performance is characterised by the maximum service speed and by the traction force profile (force at wheel rim = $F(\text{speed})$)
- (4) The unit is characterised by its running resistance and its mass.
- (5) The maximum service speed, the traction force profile and the running resistance are the unit contributions necessary to define a timetable allowing a train to slot into the overall traffic pattern on a given line, and are part of the technical documentation related to the unit described in clause 4.2.12.2 of this TSI.

▼B

4.2.8.1.2 Requirements on performance

- (1) This clause applies to units fitted with traction equipment.
- (2) Unit traction force profiles (force at wheel rim = $F(\text{speed})$) shall be determined by calculation; the unit running resistance shall be determined by a calculation for the load case 'design mass under normal payload', as defined in clause 4.2.2.10.
- (3) Unit traction force profiles and running resistance shall be recorded in the technical documentation (see clause 4.2.12.2).
- (4) The design maximum speed shall be defined from the data above for the load case 'design mass under normal payload' on a level track; design maximum speed higher than 60 km/h shall be a multiple of 5 km/h.
- (5) For units assessed in fixed or predefined formation, at the maximum service speed and on a level track, the unit shall still be capable of an acceleration of at least $0,05 \text{ m/s}^2$ for the load case 'design mass under normal payload'. This requirement may be verified by calculation or by testing (acceleration measurement) and applies for maximum design speed up to 350 km/h.
- (6) Requirements regarding the traction cut-off required in case of braking are defined in the clause 4.2.4 of this TSI.
- (7) Requirements regarding availability of the traction function in case of fire on board are defined in the clause 4.2.10.4.4.

Additional requirement for units assessed in fixed or predefined formation of maximum design speed higher than or equal to 250 km/h:

- (8) The mean acceleration on a level track, for the load case 'design mass under normal payload', shall be of at least of:
 - $0,40 \text{ m/s}^2$ from 0 to 40 km/h
 - $0,32 \text{ m/s}^2$ from 0 to 120 km/h
 - $0,17 \text{ m/s}^2$ from 0 to 160 km/h.

This requirement may be verified by calculation only or by testing (acceleration measurement) combined with calculation.
- (9) The design of the traction system shall assume a calculated wheel/rail adhesion not higher than:
 - 0,30 at start up and very low speed
 - 0,275 at 100 km/h
 - 0,19 at 200 km/h
 - 0,10 at 300 km/h.

▼ B

- (10) A single failure of power equipment affecting the traction capability shall not deprive the unit of more than 50 % of its traction force.

4.2.8.2. Power supply

4.2.8.2.1 General

- (1) Requirements applicable to rolling stock, and which interface with the Energy subsystem are dealt with in this clause; therefore, this clause 4.2.8.2 applies to electric units.
- (2) The TSI Energy specifies the following power systems: AC 25 kV 50 Hz system, AC 15 kV 16,7 Hz system, DC 3 kV system and 1,5 kV system. As a consequence, requirements defined below are related to these 4 systems only, and references to standards are valid for these 4 systems only.

4.2.8.2.2 Operation within range of voltages and frequencies

- (1) Electric units shall be able to operate within the range of at least one of the systems 'voltage and frequency' defined in the TSI Energy, clause 4.2.3.
- (2) The actual value of the line voltage shall be available in the driver cab in driving configuration.
- (3) The systems 'voltage and frequency' for which the rolling stock is designed shall be recorded in the technical documentation defined in clause 4.2.12.2 of this TSI.

4.2.8.2.3 Regenerative brake with energy to the overhead contact line

- (1) Electric units which return electrical energy to the overhead contact line in regenerative braking mode shall comply with the specification referenced in Appendix J-1, index 42.
- (2) It shall be possible to control the use of the regenerative brake.

4.2.8.2.4 Maximum power and current from the overhead contact line

- (1) Electric units with power higher than 2 MW (including the declared fixed and predefined formations) shall be equipped with power or current limitation function.
- (2) Electric units shall be equipped with automatic regulation of the current within abnormal operation condition regarding voltage; this regulation shall allow limiting the current to the 'maximum current against voltage' specified in the specification referenced in Appendix J-1, index 43.

Note: a less restrictive limitation (lower value of coefficient 'a') may be used at operating level on a particular network or line if agreed by the Infrastructure Manager.

▼B

- (3) The maximum current assessed here above (rated current) shall be recorded in the technical documentation defined in clause 4.2.12.2 of this TSI.
- 4.2.8.2.5 Maximum current at standstill for DC systems
- (1) For DC systems, the maximum current at standstill per pantograph shall be calculated and verified by measurement.
- (2) Limit values are specified in clause 4.2.5 of the TSI Energy.
- (3) The value measured and measurement conditions regarding the material of the contact wire shall be recorded in the technical documentation defined in clause 4.2.12.2 of this TSI.
- 4.2.8.2.6 Power factor
- (1) The power factor design data of the train (including multiple operation of several units as defined in clause 2.2 of this TSI) shall be subject to a calculation to verify acceptance criteria set out in the specification referenced in Appendix J-1, index 44.
- 4.2.8.2.7 System energy disturbances for ac systems
- (1) An Electric unit shall not cause unacceptable overvoltage and other phenomena described in the specification referenced in Appendix J-1, index 45, clause 10.1(harmonics and dynamic effects) on the overhead contact line.
- (2) A compatibility study shall be done in accordance with the methodology defined in the specification referenced in Appendix J-1, index 45, clause 10.3. The steps and hypothesis described in Table 5 of the same specification have to be defined by the applicant (column 3 'Concerned party' not applicable), with input data presented as in Annex D of the same specification; the acceptance criteria shall be as defined in clause 10.4 the same specification.
- (3) All hypothesis and data considered for this compatibility study shall be recorded in the technical documentation (see clause 4.2.12.2).
- 4.2.8.2.8 On-board energy measurement system
- (1) The on-board energy measurement system is the system for measurement of electric energy taken from or returned (during regenerative braking) to the overhead contact line (OCL) by the electric unit.
- (2) On-board energy measurement systems shall comply with requirements of the Appendix D of this TSI.
- (3) This system is suitable for billing purposes; the data provided by it shall be accepted for billing in all Member States.
- (4) The fitment of an on-board energy measurement system, and of its on-board location function shall be recorded in the technical documentation described in clause 4.2.12.2 of this TSI; the description of on-board to ground communication shall be part of the documentation.

▼ B

- (5) The maintenance documentation described in clause 4.2.12.3 of this TSI shall include any periodic verification procedure, in order to ensure the required accuracy level of the on-board energy measurement system during its lifetime.

4.2.8.2.9 Requirements linked to pantograph

4.2.8.2.9.1 Working range in height of pantograph

4.2.8.2.9.1.1 Height of interaction with contact wires (RST level)

The installation of a pantograph on an Electric unit shall allow mechanical contact from at least one of the contact wires at heights between:

- (1) 4 800 mm and 6 500 mm above rail level for tracks designed in accordance with the gauge GC.
- (2) 4 500 mm and 6 500 mm above rail level for tracks designed in accordance with the gauge GA/GB.
- (3) 5 550 mm and 6 800 mm above rail level for tracks designed in accordance with the gauge T (track gauge system 1 520 mm)
- (4) 5 600 mm and 6 600 mm above rail level designed in accordance with the gauge FIN1 (track gauge system 1 524 mm).

Note: current collection is verified according to clauses 6.1.3.7 and 6.2.3.21 of this TSI, specifying heights of contact wire for tests; however, current collection at low speed is assumed to be possible from a contact wire at any of the heights specified above.

4.2.8.2.9.1.2 Working range in height of pantograph (IC level)

- (1) Pantographs shall have a working range of at least 2 000 mm.
- (2) The characteristics to be verified shall be in accordance with the requirements of the specification referenced in Appendix J-1, index 46.

4.2.8.2.9.2 Pantograph head geometry (IC level)

- (1) For electric units designed to be operated on other track gauge systems than 1 520 mm system, at least one of the pantograph(s) to be installed shall have a head geometry type compliant with one of the two specifications given in the clauses 4.2.8.2.9.2.1 and 2 below.
- (2) For electric units designed to be operated solely on the 1 520 mm system, at least one of the pantograph(s) to be installed shall have a head geometry type compliant with one of the three specifications given in the clauses 4.2.8.2.9.2.1, 2 and 3 below.
- (3) The type(s) of pantograph head geometry that an Electric unit is equipped with shall be recorded in the technical documentation defined in clause 4.2.12.2 of this TSI.
- (4) The width of pantograph head shall not exceed 0,65 metres.

▼ B

- (5) Pantograph heads fitted with contact strips having independent suspensions shall be compliant with the specification referenced in Appendix J-1, index 47.
- (6) Contact between contact wire and pantograph head is permitted outside the contact strips and within the whole conducting range over limited line sections under adverse conditions, e.g. coincidence of vehicle swaying and high winds.

Conducting range and the minimum length of contact strip are specified below as part of the pantograph head geometry.

4.2.8.2.9.2.1 Pantograph head geometry type 1 600 mm

- (1) The pantograph head geometry shall be as depicted in the specification referenced in Appendix J-1, index 48.

4.2.8.2.9.2.2 Pantograph head geometry type 1 950 mm

- (1) The pantograph head geometry shall be as depicted in the specification referenced in Appendix J-1, index 49.
- (2) Insulated or non-insulated materials for the horns are both permitted.

4.2.8.2.9.2.3 Pantograph head geometry type 2 000/2 260 mm

- (1) The profile of the pantograph head shall be as depicted below:

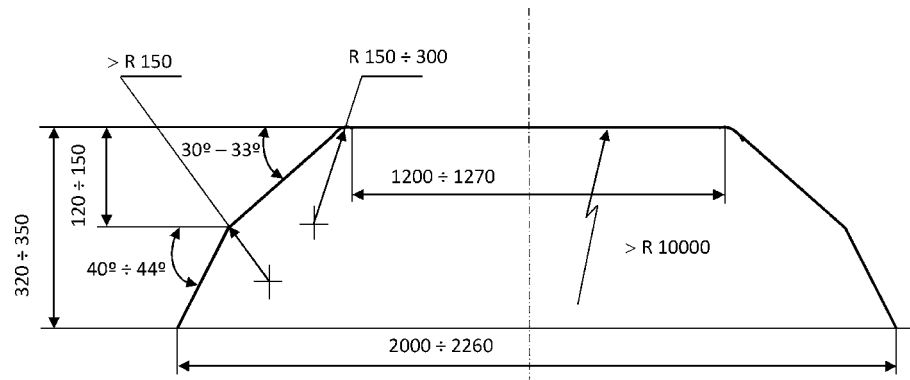

Fig. Configuration and dimensions of contact skates

4.2.8.2.9.3 Pantograph current capacity (IC level)

- (1) Pantographs shall be designed for the rated current (as defined in clause 4.2.8.2.4) to be transmitted to the Electric unit.
- (2) An analysis shall demonstrate that the pantograph is able to carry the rated current; this analysis shall include the verification of the requirements of the specification referenced in Appendix J-1, index 50.
- (3) Pantographs for DC systems shall be designed for the maximum current at standstill (as defined in clause 4.2.8.2.5 of this TSI).

4.2.8.2.9.4 Contact strip (IC level)

- (1) Contact strips are the replaceable parts of the pantograph head, which are in direct contact with the contact wire.

▼B

4.2.8.2.9.4.1 Contact strip geometry

- (1) Contact strips shall be geometrically designed to be fitted to one of the pantograph head geometries specified in clause 4.2.8.2.9.2.

4.2.8.2.9.4.2 Contact strip material

- (1) Material used for the contact strips shall be mechanically and electrically compatible with the contact wire material (as specified in clause 4.2.14 of the ENE TSI, in order to ensure proper current collection and to avoid excessive abrasion of the surface of the contact wires, thereby minimising wear of both contact wires and contact strips.
- (2) Plain carbon or impregnated carbon with additive material shall be permitted.

Where a metallic additive material is used, the metallic content of the carbon contact strips shall be copper or copper alloy and shall not exceed a content of 35 % by weight where used on AC lines and of 40 % where used on DC lines.

Pantographs assessed against this TSI shall be fitted with contact strips of a material mentioned above.

- (3) Additionally, contact strips of other material or higher percentage of metallic contents or impregnated carbon with clad copper are allowed (if permitted in the infrastructure register) provided that:

— they are referenced in recognised standards, with mention of restrictions if any, or

— they have been subject to a test of suitability for use (see clause 6.1.3.8).

4.2.8.2.9.5 Pantograph static contact force (IC level)

- (1) The static contact force is the vertical contact force exerted upward by the pantograph head on the contact wire and caused by the pantograph-raising device, when the pantograph is raised and the vehicle is at standstill.
- (2) The static contact force exerted by the pantograph on the contact wire, as defined above, shall be adjustable within at least the following ranges (consistent with the area of use of the pantograph):

— 60 N to 90 N for AC supply systems,

— 90 N to 120 N for DC 3 kV supply systems,

— 70 N to 140 N for DC 1,5 kV supply systems.

4.2.8.2.9.6 Pantograph contact force and dynamic behaviour

- (1) The mean contact force F_m is the statistical mean value of the pantograph contact force, and is formed by the static and aerodynamic components of the contact force with dynamic correction.

▼B

- (2) The factors which influence the mean contact force are the pantograph itself, its position in the train consist, its vertical extension, and the rolling stock on which the pantograph is mounted.
- (3) Rolling stock and pantographs fitted on rolling stock are designed to exert a mean contact force F_m on the contact wire in a range specified in clause 4.2.12 of the TSI Energy, in order to ensure current collection quality without undue arcing and to limit wear and hazards to contact strips. Adjustment of the contact force is made when dynamic tests are performed.
- (4) The verification at interoperability constituent level shall validate the dynamic behaviour of the pantograph itself, and its capability to collect current from a TSI compliant overhead contact line; the conformity assessment procedure specified in clause 6.1.3.7.
- (5) The verification at rolling stock subsystem level (integration in a particular vehicle) shall allow to adjust the contact force, taking into account aerodynamic effects due to the rolling stock and the position of the pantograph in the unit or train fixed or predefined formation(s); the conformity assessment procedure specified in clause 6.2.3.20.
- (6) According to the TSI Energy, the range of mean contact force F_m is not harmonised for overhead contact lines designed for speed higher than 320 km/h.

Therefore electric units can only be assessed against this TSI regarding the dynamic behaviour of the pantograph up to the speed of 320 km/h.

For the speed range above 320 km/h up to the maximum speed (if higher than 320 km/h), the procedure for innovative solutions described in article 10 and Chapter 6 of this TSI shall apply.

4.2.8.2.9.7 Arrangement of pantographs (RST level)

- (1) It is permissible for more than one pantograph to be simultaneously in contact with the overhead contact line equipment.
- (2) The number of pantographs and their spacing shall be designed taking into consideration the requirements of current collection performance, as defined in clause 4.2.8.2.9.6 above.
- (3) Where the spacing of 2 consecutive pantographs in fixed or predefined formations of the assessed unit is less than the spacing shown in clause 4.2.13 of the TSI Energy for the selected OCL design distance type, or where more than 2 pantographs are simultaneously in contact with the overhead contact line equipment, it shall be demonstrated by testing that the current collection quality as defined in clause 4.2.8.2.9.6 above is met for the poorest performing pantograph (identified by simulations to be performed prior to that test).
- (4) The OCL design distance type (A, B or C as defined in the clause 4.2.13 of the TSI Energy) selected (and therefore used for the test) shall be recorded in the technical documentation (see clause 4.2.12.2).

▼B

4.2.8.2.9.8 Running through phase or system separation sections (RST level)

- (1) Trains shall be designed to be able to move from one power supply system and from one phase section to an adjacent one (as described in clauses 4.2.15 and 4.2.16 of the TSI Energy) without bridging either system or phase separation sections.
- (2) Electric units designed for several power supply systems shall, when running through system separation sections, recognise automatically the voltage of the power supply system at the pantograph.
- (3) When running through phase or system separation sections, it shall be possible to bring the power consumption of the unit to zero. The infrastructure register gives information on the permitted pantographs position: lowered or raised (with permitted pantograph arrangements) when running through systems or phase separation sections.
- (4) Electric units of maximum design speed higher than or equal to 250 km/h shall be fitted with an on-board TCMS (train control and monitoring system) able to receive from the ground the information related to the location of the separation section, and the subsequent commands to the control of the pantograph and main circuit breaker shall be triggered automatically by the TCMS of the unit, without intervention of the driver.
- (5) Units intended to operate on lines that are fitted with the ETCS track side system for control-command and signalling shall be fitted with an on-board TCMS (train control and monitoring system) able to receive from the ETCS system the information related to the location of the separation section as described in Annex A, Index 7 of TSI CCS; for units of maximum design speed lower than 250 km/h, the subsequent commands are not required to be automatic, but information on section separation provided by ETCS shall be displayed on-board for the intervention of the driver.

4.2.8.2.9.9 Insulation of pantograph from the vehicle (RST level)

- (1) The pantographs shall be assembled on an electric unit in a way that ensures the current path from collector head to vehicle equipment is insulated. The insulation shall be adequate for all system voltages the unit is designed for.

4.2.8.2.9.10 Pantograph lowering (RST level)

- (1) Electric units shall be designed to lower the pantograph in a period meeting the requirements of the specification referenced in Appendix J-1, index 51, clause 4.7 (3 seconds) and to the dynamic insulating distance according to the specification referenced in Appendix J-1, index 52 either by initiation by the driver or by a train control function (including CCS functions).

▼ B

- (2) The pantograph shall lower to the stowed position in less than 10 seconds.

When lowering the pantograph, the main circuit breaker shall previously be opened automatically.

- (3) If an electric unit is equipped with an automatic dropping device (ADD) that lowers the pantograph in case of a collector head failure, the ADD shall meet the requirements of the specification referenced in Appendix J-1, index 51, clause 4.8.
- (4) Electric units of maximum design speed higher than 160 km/h shall be equipped with an ADD.
- (5) Electric units that require more than one pantograph raised in operation and of maximum design speed higher than 120 km/h shall be equipped with an ADD.
- (6) Other electric units are permitted to be equipped with an ADD.

4.2.8.2.10 Electrical protection of the train

- (1) Electric units shall be protected against internal short – circuits (from inside the unit).
- (2) The location of the main circuit breaker shall be such as to protect the on-board high voltage circuits, including any high voltage connections between vehicles. The pantograph, the main circuit breaker, and the high voltage connection between them shall be located on the same vehicle.
- (3) Electric units shall protect themselves against short over-voltages, temporary overvoltages and maximum fault current. To meet this requirement, electrical protection coordination design of the unit shall comply with the requirements defined in the specification referenced in Appendix J-1, index 53.

4.2.8.3 Diesel and other thermal traction system

- (1) Diesel engines are to comply with the Union legislation concerning exhaust (composition, limit values).

4.2.8.4 Protection against electrical hazards

- (1) Rolling stock and its electrically live components shall be designed such that direct or indirect contact with train staff and passenger is prevented, both in normal cases and in cases of equipment failure. Provisions described in the specification referenced in Appendix J-1, index 54 shall be applied in order to meet this requirement.

4.2.9 *Driver's Cab and driver-machine interface*

- (1) The requirements specified in this clause apply to units fitted with a driver's cab.

4.2.9.1 Driver's Cab

4.2.9.1.1 General

- (1) The driver's cabs shall be designed to permit operation by a single driver.

▼ B

- (2) The maximum noise level allowed in the cab is specified in the TSI Noise.

4.2.9.1.2 Access and egress

4.2.9.1.2.1 Access and egress in operating conditions

- (1) The driver's cab shall be accessible from both sides of the train from 200 mm below top of rail.
- (2) It is permissible for this access to be either directly from the exterior, using a cab external door, or through the area at the rear of the cab. In the latter case, requirements defined in this clause shall apply to the external accesses used for access to the cab on either side of the vehicle.
- (3) The means for the train crew to access in and to egress out of the cab, such as footsteps, handrails or opening handles, shall allow safe and easy usage by being of dimensions (pitch, width, spacing, shape) to be assessed by reference to recognised standards; they shall be designed with consideration of ergonomic criteria in relation with their use. Footsteps shall have no sharp edges causing obstacles for the shoes of the train crew.
- (4) Rolling stock with external walkways shall be equipped with handrails and foot bars (kicking strips) for driver safety when accessing the cab.
- (5) Driver's cab external doors shall open in such a way that they remain within the intended reference profile (see clause 4.2.3.1 of this TSI) when opened (the unit being at stand-still).
- (6) Driver's cab external doors shall have a minimum clearance of $1\,675 \times 500$ mm when accessible by foot-steps, or of $1\,750 \times 500$ mm when accessible on floor level.
- (7) Interior doors used by the train crew to access the cab shall have a minimum clearance of $1\,700 \times 430$ mm.
- (8) For both driver's cab external doors and internal doors, in case they are positioned perpendicular to and against the side of the vehicle, it is allowed to have the clearance width in the upper part reduced (angle on the top-outer side) due to the gauge of the vehicle; this reduction shall be strictly limited to the gauge constraint in the upper part and shall not lead to a clearance width on top side of the door lower than 280 mm.
- (9) The driver's cab and its access shall be designed so that the train crew is able to prevent the cab being accessed by non-authorised persons, whether the cab is occupied or not, and so that a cab occupant is able to go outside of a cab without having to use any tool or key.
- (10) Access to the driver's cab shall be possible without any energy supply available on board. Cab external doors shall not open unintentionally.

▼ B

4.2.9.1.2.2 Driver's cab emergency exit

- (1) In an emergency situation, evacuation of the train crew from the driver's cab and access to the interior of the cab by the rescue services shall be possible on both sides of the cab by using one of the following emergency exit means: cab external doors (access directly from the exterior, as defined in clause 4.2.9.1.2.1 above) or side windows or emergency hatches.
- (2) In all cases, the emergency exit means shall provide a minimum clearance (free area) of 2 000 cm² with a minimum inner dimension of 400 mm to allow the release of trapped persons.
- (3) Front position driver's cabs shall have at least an interior exit; this exit shall give access to an area of a minimum length of 2 metres, of a minimum clearance identical to those specified in clause 4.2.9.1.2.1, points (7) and (8), and this area (including its floor) shall be free of any obstruction to the escape of the driver; the above area shall be located on-board the unit, and can be an interior area or an area opened to the outside.

4.2.9.1.3 External visibility

4.2.9.1.3.1 Front visibility

- (1) The driver's cab shall be designed to allow the driver at his seated driving position a clear and unobstructed line of sight in order to distinguish fixed signals set to both the left and right of a straight track, and in curves with a radius of 300 m or more, under the conditions defined in Appendix F.
- (2) The above requirement shall also be met from the standing driving position under conditions defined in the Appendix F, on locomotives and on driving coaches, in case these coaches are intended to be also operated by a driver in standing position.
- (3) For locomotives with central cab and for OTMs, in order to ensure the visibility of low signals, it is permitted that the driver moves to several different positions in the cab in order to meet the above requirement; it is not required to meet the requirement from the seated driving position.

4.2.9.1.3.2 Rear and side view

- (1) The cab shall be designed to allow the driver to have a rear view of each side of the train at stand still; this requirement is permitted to be met by one of the following means: opening side windows or panel at each side of the cab, exterior mirrors, camera system.
- (2) In case of opening side windows or panel used as that means to meet the requirement above in point (1), the opening shall be sufficiently large for the driver to put his head through the aperture; additionally, for locomotives and driving coaches intended to be used in a train composition with a locomotive, the design shall allow the driver at the same time to operate the emergency brake.

▼B

4.2.9.1.4 Interior layout

- (1) The interior layout of the cab shall take into account the anthropometric measurements of the driver as set out in the Appendix E.
- (2) Freedom of movement of personnel in the cab interior shall not be inhibited by obstructions.
- (3) The cab floor corresponding to the working area of the driver (access to the cab and foot rest excluded) shall be without any step.
- (4) The interior layout shall allow both seated and standing driving positions on locomotives and on driving coaches, in case these coaches are intended to be also operated by a driver in standing position.
- (5) The cab shall be equipped with at least one driver's seat (see clause 4.2.9.1.5) and additionally with a seat not considered as a driving position for possible accompanying crew.

4.2.9.1.5 Driver's seat

Requirements at component level:

- (1) The driver's seat shall be designed in such a way that it allows him to undertake all normal driving functions in a seated position, taking into account the anthropometric measurements of the driver as set out in the Appendix E. It shall allow for correct posture of the driver from the physiological point of view.
- (2) It shall be possible for the driver to adjust the seat position in order to meet the reference position of eyes for external visibility, as defined in clause 4.2.9.1.3.1.
- (3) Ergonomics and health aspects shall be considered in the design of the seat, and its use by the driver.

Requirements for integration in the driver's cab:

- (4) The mounting of the seat in the cab shall allow to meet external visibility requirements as specified in clause 4.2.9.1.3.1 above by using the range of adjustment provided by the seat (at component level); it shall not alter ergonomics and health aspects and the use of the seat by the driver.
- (5) The seat shall not constitute an obstacle for the driver to escape in case of emergency.
- (6) The mounting of the driver's seat in locomotives, and in driving coaches, in case these coaches are intended to also be operated by a driver in standing position shall allow adjustment to get the necessary free space needed for the standing driving position.

4.2.9.1.6 Driver's desk — Ergonomics

- (1) The driver's desk and its operating equipment and controls shall be arranged to enable, in the most commonly used driving position, the driver to keep a normal posture, without hampering his freedom of movement, taking into account the anthropometric measurements of the driver as set out in the Appendix E.

▼B

- (2) To allow the display on the driver's desk surface of paper documents required during driving, a reading zone of minimum size 30 cm width per 21 cm high shall be available in front of the driver's seat.
- (3) Operating and control elements shall be clearly marked, so that they are identifiable by the driver.
- (4) If the traction and/or braking effort is set-up by a lever (combined one or separated ones), the 'tractive effort' shall increase by pushing the lever forwards, and the 'braking effort' shall increase by drawing the lever towards the driver.

If there is a position for emergency braking, it shall be clearly distinguished from those of the other positions of the lever (e.g. by a notch).

4.2.9.1.7 Climate control and air quality

- (1) The air in the cab shall be renewed to keep the CO₂ concentration to the levels specified in the clause 4.2.5.8 of this TSI.
- (2) At the seated driving position (as defined in the clause 4.2.9.1.3) of the driver's head and shoulders, there shall be no air flows caused by the ventilation system having an air velocity exceeding the limit value recognised to ensure a proper working environment.

4.2.9.1.8 Internal lighting

- (1) Cab general lighting shall be provided on driver's command in all normal operational modes of the rolling stock (included 'switched off'). Its luminosity on desk level shall be higher than 75 lux at the level of the driver's desk, except for OTMs for which it shall be higher than 60 lux.
- (2) Independent lighting of the driver's desk reading zone shall be provided on driver's command, and shall be adjustable up to a value higher than 150 lux.
- (3) An independent lighting of instruments shall be provided, and shall be adjustable.
- (4) In order to prevent any dangerous confusion with outside operational signalling, no green lights or green illumination are permitted in a driver's cab, except for existing class B cab signalling systems (as defined in the CCS TSI).

4.2.9.2. Windscreen

4.2.9.2.1. Mechanical characteristics

- (1) The dimension, location, shape and finishes (including those for maintenance purpose) of the windows shall not inhibit the drivers external view (as defined in clause 4.2.9.1.3.1) and shall support the driving task.
- (2) The driver's cab windscreens shall be able to resist impacts from projectiles as specified in the specification referenced in Appendix J-1, index 55, clause 4.2.7 and shall resist spalling as specified in the same specification, clause 4.2.9.

▼ B

4.2.9.2.2. Optical characteristics

- (1) The driver's cab windscreens shall be of an optical quality that does not alter the visibility of signs (shape and colour) in any operating condition (including as example when the windscreen is heated to prevent misting and frost).
- (2) The angle between primary and secondary images in the installed position shall be in accordance with limit values specified in the specification referenced in Appendix J-1, index 56, clause 4.2.2.
- (3) Permissible optical distortions of vision shall be as specified in the specification referenced in Appendix J-1, index 56, clause 4.2.3.
- (4) Haze shall be as specified in the specification referenced in Appendix J-1, index 56, clause 4.2.4.
- (5) Luminous transmittance shall be as specified in the specification referenced in Appendix J-1, index 56, clause 4.2.5.
- (6) Chromaticity shall be as specified in the specification referenced in Appendix J-1, index 56, clause 4.2.6.

4.2.9.2.3 Equipment

- (1) The windscreen shall be equipped with de-icing, de-misting and external cleaning means, under control of the driver.
- (2) The location, type and quality of windscreen cleaning and clearance devices shall ensure that the driver is able to maintain a clear external view in most weather and operating conditions, and shall not inhibit the drivers external view.
- (3) Protection shall be provided from the sun without reducing the drivers' view of external signs, signals and other visual information when this protection is in its stowed position.

4.2.9.3. Driver machine interface

4.2.9.3.1. Driver's activity control function

- (1) The driver's cab shall be equipped with a means to monitor the driver's activity, and to automatically stop the train when a lack of driver's activity is detected. This gives the on-board technical means for the railway undertaking to fulfil the requirement of clause 4.2.2.9 of TSI OPE.
- (2) **Specification of the means to monitor (and detect a lack of) the driver's activity:**

The driver's activity shall be monitored when the train is in driving configuration and is moving (criterion for movement detection is at a low speed threshold); this monitoring shall be done by controlling the action of the driver on recognised driver interfaces such as dedicated devices (e.g. pedal, push buttons, sensitive touches...) and/or recognised driver interfaces with the Train Control and Monitoring System.

When no action is monitored on any of the recognised driver interfaces during more than a time of X seconds, a lack of driver's activity shall be triggered.

▼ B

The system shall allow for the adjustment (at workshop, as a maintenance activity) of the time X within the range of 5 seconds to 60 seconds.

When the same action is monitored continuously for more than a time not higher than 60 seconds without any further action on a recognised driver interface, a lack of driver's activity shall also be triggered.

Before triggering a lack of driver's activity, a warning shall be given to the driver, in order for him to have the possibility to react and reset the system.

The system shall have the information 'lack of driver's activity triggered' available for being interfaced to other systems (i.e. the radio system).

(3) **Additional requirement:**

The detection of the lack of the driver's activity is a function that shall be subject to a reliability study considering the failure mode of components, redundancies, software, periodic checks and other provisions, and the estimated failure rate of the function (lack of driver's activity as specified above not detected) shall be provided in the technical documentation defined in clause 4.2.12.

(4) **Specification of actions triggered at train level when a lack of driver's activity is detected:**

A lack of driver's activity when the train is in driving configuration and is moving (criterion for movement detection is at a low speed threshold) shall lead to a full service brake or an emergency brake application on the train.

In case of application of a full service brake, its effective application shall be automatically controlled and in case of non-application, it shall be followed by an emergency brake.

(5) **Notes:**

— It is allowed to have the function described in this clause fulfilled by the CCS Subsystem.

— The value of the time X has to be defined and justified by the railway undertaking (application of TSI OPE and CSM, and consideration of its current code of practice or means of compliance; outside of scope of the present TSI).

— As a transitional measure, it is also allowed to install a system of a fix time X (no adjustment possible) provided that the time X is within the range of 5 seconds to 60 seconds and that the railway undertaking can justify this fix time (as described above).

— A Member State may impose to the railway undertakings operating on its territory to adjust their rolling stock with a maximum limit for time X, if the Member state can demonstrate that this is needed to preserve the national safety level. In all other cases, Member States cannot prevent the access of a railway undertaking that is using a higher time Z (within the range specified).

▼ B

4.2.9.3.2. Speed indication

- (1) This function and the corresponding conformity assessment are specified in the TSI CCS.

4.2.9.3.3 Driver display unit and screens

- (1) Functional requirements concerning the information and commands provided in the driver's cab are specified together with other requirements applicable to the specific function, in the clause describing that function. The same applies also to information and commands that may be provided by means of display units and screens.

ERTMS information and commands, including those provided on a display unit, are specified in the TSI CCS.

- (2) For functions in the scope of this TSI, the information or commands to be used by the driver to control and command the train, and given by means of display units or screens, shall be designed to allow proper use and reaction from the driver.

4.2.9.3.4. Controls and indicators

- (1) Functional requirements are specified with other requirements applicable to a specific function, in the clause describing that function.
- (2) All indicator lights shall be designed so that they can be read correctly under natural or artificial lighting conditions, including incidental lighting.
- (3) Possible reflections of illuminated indicators and buttons in the windows of the driver's cab shall not interfere with the line of sight of the driver in his normal working position.
- (4) In order to prevent any dangerous confusion with outside operational signalling, no green lights or green illumination are permitted in a driver's cab, except for existing class B cab signalling system (according TSI CCS).
- (5) Audible information generated by on-board equipment inside the cab for the driver shall be at least 6 dB(A) above the noise level in the cab (this noise level taken as reference being measured under conditions specified in the TSI Noise).

4.2.9.3.5. Labelling

- (1) The following information shall be indicated in the driving cabs:

— Max. speed (V_{max}),

— Identification number of rolling stock (traction vehicle number),

— Location of portable equipment (e.g. self-rescue device, signals),

— Emergency exit.

▼ B

- (2) Harmonised pictograms shall be used to mark controls and indicators in the cab.
- 4.2.9.3.6 Radio Remote control function by staff for shunting operation
- (1) If a radio remote control function is provided for a staff member to control the unit during shunting operations, it shall be designed to allow him to control the train movement safely, and to avoid any mistake when used.
- (2) It is assumed that the staff member using the remote control function can visually detect train movement when using the remote control device.
- (3) The design of the remote control function, including safety aspects, shall be assessed according to recognised standards.
- 4.2.9.4. On-board tools and portable equipment
- (1) A space shall be available in or near the driver's cab to store the following equipment, in case they are needed by the driver in emergency situation:
- Hand-lamp with red and white light
 - Short circuiting equipment for track-circuits
 - Scotches, if the parking brake performance is not sufficient depending on track gradient (see clause 4.2.4.5.5 'Parking brake').
 - A fire extinguisher (to be located in the cab; see also clause 4.2.10.3.1).
 - On manned traction units of freight trains: a self-rescue device, as specified in the SRT TSI (see SRT TSI clause 4.7.1).
- 4.2.9.5. Storage facility for staff personal effects
- (1) Each driver's cab shall be equipped with:
- Two hooks for clothing or a niche with a clothes beam.
 - A free space for storing a suitcase or bag of size 300 mm × 400 mm × 400 mm.
- 4.2.9.6. Recording device
- (1) The list of information to be recorded is defined in the TSI OPE.
- (2) The unit shall be equipped with a means to record this information, complying with the following requirements:
- (3) Functional requirements specified in the specification referenced in Appendix J-1, index 57, clauses 4.2.1, 4.2.2, 4.2.3 and 4.2.4 shall be met.
- (4) Recording performance shall be according to class R1 of the specification referenced in Appendix J-1, index 57, clause 4.3.1.2.2.

▼ B

- (5) The integrity (consistency; correctness) of the recorded and extracted data shall be according to the specification referenced in Appendix J-1, index 57, clause 4.3.1.4.
- (6) Data integrity shall be safeguarded according to the specification referenced in Appendix J-1, index 57, clause 4.3.1.5.
- (7) The level of protection that applies to the protected storage medium shall be 'A' as defined in the specification referenced in Appendix J-1, index 57, clause 4.3.1.7.

4.2.10. *Fire safety and evacuation*4.2.10.1. **General and Categorisation**

- (1) This clause applies to all units.
- (2) Rolling stock shall be designed such that it protects passengers and on-board staff in case of hazard fire on board and to allow an effective evacuation and rescue in case of emergencies. This is deemed to be fulfilled by complying with the requirements of this TSI.
- (3) The category of the unit regarding fire safety considered for its design, as defined in clause 4.1.4 of this TSI shall be recorded in the technical documentation described in clause 4.2.12 of this TSI.

4.2.10.2. **Measures to prevent fire**4.2.10.2.1 **Material requirements**

- (1) The selection of materials and components shall take into account their fire behaviour properties, such as flammability, smoke opacity and toxicity.
- (2) Materials used to construct the rolling stock unit shall comply with the requirements of the specification referenced in Appendix J-1, index 58 for the 'Operation Category' as defined below:
 - 'Operation Category 2' for Category A passenger rolling stock (including passenger locomotive).
 - 'Operation Category 3' for Category B passenger rolling stock (including passenger locomotive).
 - 'Operation Category 2' for freight locomotives, and self-propelling units designed to carry other payload (mail, freight, etc.).
 - 'Operation Category 1' for OTMs, with requirements limited to areas which are accessible to staff when the unit is in transport running configuration (see Section 2.3 of this TSI).
- (3) In order to ensure constant product characteristics and manufacturing process, it is required that:
 - the certificate to prove compliance of a material with the standard, which shall be issued immediately after testing of this material, shall be reviewed every 5 years,

▼B

— in case there is no change in the product characteristics and manufacturing process, and no change in the requirements (TSI), it is not required to perform new testing of this material; the certificate needs only to be updated regarding its date of issue.

4.2.10.2.2 Specific measures for flammable liquids

- (1) Railway vehicles shall be provided with measures preventing a fire from occurring and spreading due to leakage of flammable liquids or gases.
- (2) Flammable liquids used as cooling medium in high voltage equipment of freight locomotives shall be compliant to the requirement R14 of the specification referenced in Appendix J-1, index 59.

4.2.10.2.3 Hot axle box detection

Requirements are specified in clause 4.2.3.3.2 of the present TSI.

4.2.10.3. Measures to detect/control fire**4.2.10.3.1** Portable Fire extinguishers

- (1) This clause is applicable to units designed to carry passengers and/or staff.
- (2) The unit shall be equipped with adequate and sufficient portable fire extinguishers, in passenger and/or staff areas.
- (3) Water plus additive type fire extinguishers are deemed to be adequate for on-board rolling stock purposes.

4.2.10.3.2 Fire detection systems

- (1) The equipment and the areas on rolling stock that intrinsically impose a fire risk shall be equipped with a system that will detect fire at an early stage.
- (2) Upon fire detection the driver shall be notified and appropriate automatic actions shall be initiated to minimize the subsequent risk to passengers and train staff.
- (3) For sleeping compartments, the detection of a fire shall activate an acoustic and optical local alarm in the affected area. The acoustic signal shall be sufficient to wake up the passengers. The optical signal shall be clearly visible and shall not be hidden by obstacles.

4.2.10.3.3 Fire automatic fighting system for freight diesel units

- (1) This clause is applicable to diesel powered freight locomotives and diesel powered freight self-propelling units.
- (2) These units shall be equipped with an automatic system capable of detecting a diesel fuel fire and of shutting down all relevant equipment and cutting off the fuel supply.

4.2.10.3.4 Fire containment and control systems for passenger rolling stock

- (1) This clause is applicable to units of category B passenger rolling stock.

▼B

- (2) The unit shall be equipped with adequate measures to control the spread of heat and fire effluents through the train.
- (3) The conformity with this requirement shall be deemed to be satisfied by the verification of conformity to the following requirements:
- The unit shall be equipped with full cross section partitions within passenger/staff areas of each vehicle, with a maximum separation of 30 meters which shall satisfy requirements for integrity for a minimum of 15 minutes (assuming the fire can start from either side of the partition), or with other Fire Containment and Control Systems (FCCS).
 - The unit shall be equipped with fire barriers that shall satisfy requirements for integrity and heat insulation for a minimum of 15 minutes at the following locations (where relevant for the concerned unit):
 - Between the drivers cab and the compartment to the rear of it (assuming the fire starts in the rear compartment).
 - Between combustion engine and adjacent passenger/staff areas (assuming the fire starts in the combustion engine).
 - Between compartments with electrical supply line and/or traction circuit equipment and passenger/staff area (assuming the fire starts in the electrical supply line and/or the traction circuit equipment).
 - The test shall be carried out in accordance with the requirements of the specification referenced in Appendix J-1, index 60.
- (4) If other FCCS are used instead of full cross section partitions within passenger/staff areas, the following requirements shall apply:
- They shall be installed in each vehicle of the unit, which is intended to carry passengers and/or staff,
 - They shall ensure that fire and smoke will not extend in dangerous concentrations over a length of more than 30 m within the passenger/staff areas inside the unit, for at least 15 minutes after the start of a fire.

The assessment of this parameter is an open point.

- (5) If other FCCS are used and rely on reliability and availability of systems, components, or functions, they shall be subject to a reliability study considering the failure mode of components, redundancies, software, periodic checks and other provisions, and the estimated failure rate of the function (lack of control of the spread of heat and fire effluents) shall be provided in the technical documentation described in clause 4.2.12.

Based on this study, operating and maintenance conditions of the FCCS shall be defined and provided in the maintenance and operating documentation described in clauses 4.2.12.3 and 4.2.12.4.

▼B

4.2.10.3.5 Fire spreading protection measures for freight locomotives and freight self-propelling units

- (1) This clause is applicable to freight locomotives and to freight self-propelling units.
- (2) These units shall have a fire barrier to protect the driver's cab.
- (3) These fire barriers shall satisfy requirements for integrity and heat insulation for a minimum of 15 minutes; they shall be subject to a test carried out in accordance with the requirements of the specification referenced in Appendix J-1, index 61.

4.2.10.4. Requirements related to emergencies

4.2.10.4.1. Emergency lighting

- (1) To provide protection and safety on board in the event of emergency the trains shall be equipped with an emergency lighting system. This system shall provide a suitable lighting level in the passenger and in the service areas, as follows:
 - (2) for units of maximum design speed higher than or equal to 250 km/h, during a minimum operating time of three hours after the main energy supply has failed,
 - (3) for units of maximum design speed lower than 250 km/h, during a minimum operating time of 90 minutes after the main energy supply has failed.
- (4) Lighting level of at least 5 lux at floor level.
- (5) Values of lighting level for specific areas and conformity assessment methods shall be as specified in the specification referenced in Appendix J-1, index 62.
- (6) In the event of fire, the emergency lighting system shall continue to sustain at least 50 % of the emergency lighting in the vehicles not affected by fire for a minimum of 20 minutes. This requirement shall be deemed to be fulfilled by a satisfactory failure mode analysis.

4.2.10.4.2 Smoke Control

- (1) This clause is applicable to all units. In case of fire, the distribution of fumes shall be minimised in areas occupied by passengers and/or staff by application of the following requirements:

- (2) To prevent outside smoke from entering the unit, it shall be possible to switch off or close all means of external ventilation.

This requirement is verified on the rolling stock subsystem at unit level.

- (3) To prevent smoke that could be inside a vehicle from spreading, it shall be possible to switch off the ventilation and recirculation at vehicle level, this may be achieved by switching off the ventilation.
- (4) It is permissible to trigger these actions manually by the on-board staff, or by remote control; the triggering is permitted to be at train level, or at vehicle level.

▼B

- (5) For units intended to operate on lines that are fitted with the ETCS track side system for control-command and signalling (including ‘airtightness’ information as described in Annex A, Index 7 of TSI CCS), the unit on-board control system shall be able to receive from the ETCS system the information related to airtightness.

4.2.10.4.3 Passenger alarm and communication means

Requirements are specified in clauses 4.2.5.2, 4.2.5.3 and 4.2.5.4 of the present TSI.

4.2.10.4.4 Running capability

- (1) This clause is applicable to category A and category B passenger rolling stock (including passenger locomotives).
- (2) The unit shall be designed so that, in the event of fire on-board, the running capability of the train will enable it to run to a suitable firefighting point.
- (3) Compliance shall be demonstrated by application of the specification referenced in Appendix J-1, index 63, in which the system functions impacted by a ‘type 2’ fire shall be:

— braking for rolling stock of fire safety category A: this function shall be assessed for a duration of 4 minutes.

— braking and traction for rolling stock of fire safety category B: these functions shall be assessed for a duration of 15 minutes at a minimum speed of 80 km/h.

4.2.10.5. Requirements related to evacuation

4.2.10.5.1. Passenger emergency exits

- (1) This section is applicable to units designed to carry passengers.

Definitions and clarifications

- (2) Emergency exit: train borne provision to allow people inside the train to get out of the train in case of an emergency. An external passenger door is a specific type of emergency exit.
- (3) Through route: route through the train which can be entered and exited from different ends and which permits the movement of passengers and staff, along the longitudinal axis of the train without obstruction. Interior doors on the through route which are intended to be used by passengers in normal service and which can also be opened in case of power failure are considered not to obstruct the movement of passengers and staff.
- (4) Passenger area: area to which passengers have access without particular authorisation.
- (5) Compartment: Passenger area or staff area, which cannot be used as a through route for passengers or staff respectively.

Requirements

- (6) Emergency exits shall be provided in sufficient quantity along through route(s) on both sides of the unit; they shall be indicated. They shall be accessible and sufficient in size to allow the release of persons.

▼B

- (7) An emergency exit shall be able to be opened by a passenger from inside the train.
- (8) All external passenger doors shall be equipped with emergency opening devices allowing them to be used as emergency exits (see clause 4.2.5.5.9).
- (9) Each vehicle designed to contain up to 40 passengers shall have at least two emergency exits.
- (10) Each vehicle designed to contain more than 40 passengers shall have at least three emergency exits.
- (11) Each vehicle intended to carry passengers shall have at least one emergency exit on each vehicle side.
- (12) The number of the doors and their dimensions shall allow the complete evacuation within three minutes by passengers without their baggage. It is permitted to consider that passengers with reduced mobility are to be assisted by other passengers or staff, and that wheelchair users are evacuated without their wheelchair.

Verification of this requirement shall be made by a physical test under normal operating conditions.

4.2.10.5.2 Driver's cab emergency exits

Requirements are specified in clause 4.2.9.1.2.2 of the present TSI.

4.2.11. Servicing

4.2.11.1. General

- (1) Servicing and minor repairs necessary to ensure safe operations between maintenance interventions shall be able to be carried out while the train is stabled away from its normal servicing home base.
- (2) This part gathers requirements for provisions relating to the servicing of trains during operation or when stabled on a network. Most of these requirements aim at ensuring that rolling stock will have the equipment necessary to meet the provisions required in the other sections of this TSI and of the TSI Infrastructure.
- (3) Trains shall be capable of remaining stabled, with no crew onboard, with power supply from the catenary or auxiliary power supply maintained for lighting, air conditioning, refrigerated cabinets, etc.

4.2.11.2. Train exterior cleaning

4.2.11.2.1 Cleaning of driver's cab windscreen

- (1) This clause is applicable to all units equipped with a driver's cab
- (2) It shall be possible for the front windows of drivers' cabs to be cleaned from outside the train without need to remove any component or covering.

4.2.11.2.2 Exterior cleaning through a washing plant

- (1) This clause is applicable to units fitted with traction equipment that are intended to be cleaned externally through a washing plant.

▼B

- (2) It shall be possible to control the speed of trains that are intended to be cleaned externally through a washing plant on level track at a value between 2 km/h and 5 km/h. This requirement is aimed at ensuring compatibility with washing plants.

4.2.11.3. Connection to Toilet discharge system

- (1) This clause is applicable to units equipped with sealed retention systems (using clear or recycled water) that have to be emptied at sufficient intervals on a scheduled basis at designated depots.
- (2) The following connections of the unit to the toilet discharge system shall comply with the following specifications:

— The 3 Evacuation nozzle (Inner part): see Appendix G-1.

— The flushing connection for the toilet tank (Inner part), the use of which is optional: see Appendix G-1.

4.2.11.4. Water refilling equipment

- (1) This clause is applicable to units equipped with water taps covered by the clause 4.2.5.1 of this TSI.
- (2) The water supplied to the train, up to the filling-interface with the rolling stock, on the interoperable network is deemed to be drinking water in accordance with Directive 98/83/EC, as specified in the clause 4.2.12.4 of the TSI INF.

The on-board storage equipment shall not induce any additional risk for the health of people to the risks associated with the storage of water filled in accordance with the above provisions. This requirement is deemed to be met by assessment of piping and sealing material and quality. The materials shall be suitable for transport and storage of water fit for human consumption.

4.2.11.5. Interface for water refilling

- (1) This clause is applicable to units equipped with a water tank supplying water to sanitary systems covered by the clause 4.2.5.1 of this TSI.
- (2) The inlet connection for water tanks shall comply with figure 1of the specification referenced in Appendix J-1, index 64.

4.2.11.6. Special requirements for stabling of trains

- (1) This clause is applicable to units intended to be powered while stabled.
- (2) The unit shall be compatible with at least one of the following external power supply systems, and shall be equipped (where relevant) with the corresponding interface for electrical connection to that external power supply (plug):
- (3) Power supply contact line (see clause 4.2.8.2.9 'Requirements linked to pantograph'),
- (4) 'UIC 552-type' train power supply line (AC 1 kV, AC/DC 1.5 kV, DC 3 kV),

▼B

- (5) Local external auxiliary power supply 400 V that can be connected to socket type '3P+ground' according to the specification referenced in Appendix J-1, index 65.

4.2.11.7. Refuelling equipment

- (1) This clause is applicable to units equipped with a refuelling system.
- (2) Trains using diesel fuel in accordance with Annex II of Directive 2009/30/EC of the European Parliament and of the Council ⁽¹⁾ shall be equipped with refuelling couplings on both sides of the vehicle, at a maximum height of 1 500 mm above rail level; they shall be circular with a minimum diameter of 70 mm.
- (3) Trains using another type of diesel fuel shall be equipped with a foolproof opening and fuel tank to prevent inadvertent refuelling with a wrong fuel.
- (4) The type of coupling for refuelling shall be recorded in the technical documentation.

4.2.11.8. Train interior cleaning — power supply

- (1) For units of maximum speed higher than or equal to 250 km/h, a 3 000 VA at 230V, 50Hz electrical power supply connection shall be provided inside the unit; they shall be spaced such that no part of the unit that needs to be cleaned is more than 12 metres from one of the sockets.

4.2.12. Documentation for operation and maintenance

- (1) The requirements specified in this clause 4.2.12 apply to all units.

4.2.12.1. General

- (1) This clause 4.2.12 of the TSI describes the documentation requested in clause 2.4 of Annex VI of Directive 2008/57/EC (clause titled 'Technical file'): *'technical characteristics linked to the design including general and detailed drawings with respect to execution, electrical and hydraulic diagrams, control-circuit diagrams, description of data-processing and automatic systems, documentation on operation and maintenance, etc., relevant for the subsystem concerned.'*
- (2) This documentation, being part of the technical file, is compiled by the notified body and has to accompany the EC declaration of verification.
- (3) This documentation, being part of the technical file, is lodged with the applicant, and is kept by the applicant throughout the service life of the subsystem.
- (4) The documentation requested is related to the basic parameters identified in this TSI. Its content is described in the clauses below.

⁽¹⁾ Directive 2009/30/EC of the European Parliament and of the Council of 23 April 2009 amending Directive 98/70/EC as regards the specification of petrol, diesel and gas-oil and introducing a mechanism to monitor and reduce greenhouse gas emissions and amending Council Directive 1999/32/EC as regards the specification of fuel used by inland waterway vessels and repealing Directive 93/12/EEC (OJ L 140, 5.6.2009, p. 88).

▼B

4.2.12.2. General documentation

The following documentation describing the rolling stock shall be provided:

- (1) General drawings.
- (2) Electrical, pneumatic and hydraulic diagrams, Control-circuit diagrams necessary to explain the function and operation of the concerned systems.
- (3) Description of computerised on-board systems including description of functionality, specification of interfaces and data processing and protocols.
- (4) Reference profile, and compliance to interoperable reference contours G1, GA, GB, GC or DE3, as required in clause 4.2.3.1.
- (5) Weight balance with hypothesis on load conditions considered, as required in clause 4.2.2.10.
- (6) Axle load and spacing of axles, as required in clause 4.2.3.2.1.
- (7) Test report concerning running dynamic behaviour, including the test track quality recording and the track loading parameters including possible limitations of use if testing of the vehicle only covers a part of the test conditions, as required in clause 4.2.3.4.2.
- (8) The hypothesis taken to evaluate the loads due to bogie running, as required in clauses 4.2.3.5.1 and in clause 6.2.3.7 for wheelsets.
- (9) Braking performance, including failure mode analysis (degraded mode) as required in clause 4.2.4.5.
- (10) The presence and type of toilets in a unit, the characteristics of the flushing medium, if it is not clean water, the nature of the treatment system for released water and the standards against which conformity has been assessed, as required in clause 4.2.5.1.
- (11) Provisions taken in relation with the selected range of environmental parameters if different than the nominal one, as required in clause 4.2.6.1.
- (12) Characteristic wind curve (CWC) as required in clause 4.2.6.2.4.
- (13) Traction performance, as required in clause 4.2.8.1.1.
- (14) Fitment of an on-board energy measurement system, and of its on-board location function (optional), as required in clause 4.2.8.2.8; description of on-board to ground communication.
- (15) Hypothesis and data considered for the compatibility study for AC systems, as required in clause 4.2.8.2.7.
- (16) The number of pantographs simultaneously in contact with the overhead contact line equipment (OCL), their spacing and the OCL design distance type (A, B or C) used for assessment tests, as required in clause 4.2.8.2.9.7.

▼B

4.2.12.3. Documentation related to Maintenance

- (1) Maintenance is a set of activities intended to keep a functional unit in, or to restore it to, a state in which it can perform its required function, ensuring continued integrity of safety systems and compliance with applicable standards.

The following information necessary to undertake maintenance activities on rolling stock shall be provided:

- (2) The maintenance design justification file: explains how maintenance activities are defined and designed in order to ensure that the rolling stock characteristics will be kept within acceptable limits of use during its lifetime.

The file shall give input data in order to determine the criteria for inspection and the periodicity of maintenance activities.

- (3) The maintenance description file: explains how maintenance activities shall be performed.

4.2.12.3.1 The maintenance design justification file

The maintenance design justification file shall contain:

- (1) Precedents, principles and methods used to design the maintenance of the unit.
- (2) Utilisation profile: Limits of the normal use of the unit (e.g. km/month, climatic limits, authorised types of loads etc.).
- (3) Relevant data used to design the maintenance and origin of these data (return of experience).
- (4) Tests, investigations and calculations carried out to design the maintenance.

Resultant means (facilities, tools...) needed for the maintenance are described in clause 4.2.12.3.2 'maintenance documentation'.

4.2.12.3.2 The Maintenance description file

- (1) The maintenance description file shall describe how maintenance activities shall be conducted.
- (2) Maintenance activities include all activities necessary such as inspections, monitoring, tests, measurements, replacements, adjustments, repairs.
- (3) Maintenance activities are split into:

— Preventive maintenance; scheduled and controlled

— Corrective maintenance.

The maintenance description file shall include the following:

- (4) Component hierarchy and functional description: The hierarchy sets up the boundaries of the rolling stock by listing all the items belonging to the product structure of that rolling stock and using an appropriate number of discrete levels. The lowest item of the hierarchy shall be a replaceable unit.

▼ B

- (5) Schematic circuit diagrams, connection diagrams and wiring diagrams
- (6) Parts list: The parts list shall contain the technical and functional descriptions of the spare parts (replaceable units).

The list shall include all parts specified for changing on condition, or which may require replacement following electrical or mechanical malfunction, or which will foreseeable require replacement after accidental damage (e.g. wind-screen).

Interoperability constituent shall be indicated and referenced to their corresponding declaration of conformity.

- (7) The limit values for components which shall not be exceeded in service shall be stated; the possibility of specifying operational restrictions in degraded mode (limit value reached) is permitted.
- (8) European legal obligations: where components or systems are subject to specific European legal obligations these obligations shall be listed.
- (9) The structured set of tasks that include the activities, procedures, means proposed by the applicant to carry out the maintenance task.
- (10) The description of the maintenance activities.

The following aspects have to be documented (when they are specific to the application):

- Disassembly/assembly instructions drawings necessary for correct assembly/disassembly of replaceable parts
- Maintenance criteria
- Checks and tests
- Tools and materials required to undertake the task (special tools)
- Consumables required to undertake the task
- Personal protective safety provision and equipment (special).

- (11) Necessary tests and procedures to be undertaken after each maintenance operation before re-entry into service of rolling stock.
- (12) Troubleshooting (fault diagnosis) manuals or facilities for all reasonably foreseeable situations; this includes functional and schematic diagrams of the systems or IT-based fault finding systems.

4.2.12.4. Operating documentation

The technical documentation necessary to operate the unit is composed of:

- (1) A description of operation in normal mode, including the operational characteristics and limitations of the unit (e.g. vehicle gauge, maximum design speed, axle loads, brake performance...).

▼B

- (2) A description of the various reasonably foreseeable degraded modes in case of safety significant failures of equipment or functions described in this TSI, together with the related acceptable limits and operating conditions of the unit that could be experienced.
- (3) A description of the control and monitoring systems allowing the identification of safety significant failures of equipment or functions described in this TSI (e.g. clause 4.2.4.9 related to the function 'braking').
- (4) This technical operating documentation shall be part of the technical file.

4.2.12.5. **Lifting diagram and instructions**

The documentation shall include:

- (1) A description of procedures for lifting and jacking and related instructions.
- (2) A description of interfaces for lifting and jacking.

4.2.12.6. **Rescue related descriptions**

The documentation shall include:

- (1) A description of procedures for use of emergency measures and related necessary precautions to be taken, as e.g. use of emergency exits, entrance to RST for rescue, isolation of brakes, electrical earthing, towing.
- (2) A description of effects when the described emergency measures are taken, e.g. reduction of brake performance after isolation of brakes.

4.3. **Functional and technical specification of the interfaces**4.3.1. *Interface with Energy subsystem*

Table 6

Interface with the Energy subsystem

Reference LOC & PAS TSI		Reference Energy TSI	
Parameter	Point	Parameter	Point
Gauging	4.2.3.1	Pantograph gauge	4.2.10
Pantograph head geometry	4.2.8.2.9.2		Appendix D
Operation within range of voltages and frequencies	4.2.8.2.2	Voltage and frequency	4.2.3
		Parameters relating to supply system performance:	
— Max current from OCL	4.2.8.2.4	— Max train current	4.2.4
— Power factor	4.2.8.2.6	— Power factor	4.2.4
		— Mean useful voltage	4.2.4

▼ B

Reference LOC & PAS TSI		Reference Energy TSI	
Parameter	Point	Parameter	Point
— Maximum current at standstill	4.2.8.2.5	— Current capacity DC systems trains at standstill	4.2.5
Regenerative brake with energy to OCL	4.2.8.2.3	Regenerative braking	4.2.6
Energy consumption measuring function	4.2.8.2.8	On-ground energy data collecting system	4.2.17
— Height of pantograph	4.2.8.2.9.1	Geometry of the overhead contact line	4.2.9
— Pantograph head geometry	4.2.8.2.9.2		
Contact strip material	4.2.8.2.9.4	Contact wire material	4.2.14
Pantograph static contact force	4.2.8.2.9.5	Mean contact force	4.2.11
Pantograph contact force and dynamic behaviour	4.2.8.2.9.6	Dynamic behaviour and quality of current collection	4.2.12
Arrangements of pantographs	4.2.8.2.9.7	Pantograph spacing	4.2.13
Running through phase or system separation section	4.2.8.2.9.8	Separation sections:	
		— phase	4.2.15
		— system	4.2.16
Electrical protection of the train	4.2.8.2.10	Electrical Protection Coordination Arrangements	4.2.7
System energy disturbances for AC systems	4.2.8.2.7	Harmonics and Dynamic Effects for AC traction power supply systems	4.2.8

4.3.2. *Interface with Infrastructure subsystem*

Table 7

Interface with the Infrastructure subsystem

Reference LOC & PAS TSI		Reference Infrastructure TSI	
Parameter	Point	Parameter	Point
Rolling stock kinematic gauge	4.2.3.1.	Structure gauge	4.2.3.1
		Distance between track centres	4.2.3.2
		Minimum radius of vertical curve	4.2.3.5
Axle load parameter	4.2.3.2.1	Track resistance to vertical loads	4.2.6.1
		Lateral track resistance	4.2.6.3

▼B

Reference LOC & PAS TSI		Reference Infrastructure TSI	
Parameter	Point	Parameter	Point
		Resistance of new bridges to traffic loads	4.2.7.1
		Equivalent vertical loading for new earthworks and earth pressure effects	4.2.7.2
		Resistance of existing bridges and earthworks to traffic loads	4.2.7.4
Running dynamic behaviour	4.2.3.4.2.	Cant deficiency	4.2.4.3
Running dynamic limit values for track loading	4.2.3.4.2.2	Track resistance to vertical loads	4.2.6.1
		Lateral track resistance	4.2.6.3
Equivalent conicity	4.2.3.4.3	Equivalent conicity	4.2.4.5
Geometrical characteristics of wheelset	4.2.3.5.2.1	Nominal track gauge	4.2.4.1
Geometrical characteristics of wheels	4.2.3.5.2.2	Rail head profile for plain line	4.2.4.6
Variable gauge wheelsets	4.2.3.5.2.3	In service geometry of switches and crossings	4.2.5.3
Minimum curve radius	4.2.3.6	Minimum radius of horizontal curve	4.2.3.4
Maximum average deceleration	4.2.4.5.1	Longitudinal track resistance	4.2.6.2
		Actions due to traction and braking	4.2.7.1.5
Slipstream effects	4.2.6.2.1	Resistance of new structures over or adjacent to tracks	4.2.7.3
Head pressure pulse	4.2.6.2.2	Maximum pressure variations in tunnels	4.2.10.1
Maximum pressure variations in tunnels	4.2.6.2.3	Distance between track centres	4.2.3.2
Crosswind	4.2.6.2.4	Effect of crosswinds	4.2.10.2
Aerodynamic effect on ballasted track	4.2.6.2.5	Ballast pick-up	4.2.10.3
Toilet discharge system	4.2.11.3	Toilet discharge	4.2.12.2

▼ B

Reference LOC & PAS TSI		Reference Infrastructure TSI	
Parameter	Point	Parameter	Point
Exterior cleaning through a washing plant	4.2.11.2.2	Train external cleaning facilities,	4.2.12.3
Water refilling equipment:	4.2.11.4	Water restocking,	4.2.12.4
Interface for water refilling	4.2.11.5		
Refuelling equipment	4.2.11.7	Refuelling	4.2.12.5
Special requirements for stabling of trains	4.2.11.6	Electric shore supply	4.2.12.6

4.3.3. *Interface with Operation subsystem*

Table 8

Interface with the Operation subsystem

Reference LOC & PAS TSI		Reference Operation TSI	
Parameter	Point	Parameter	Point
Rescue coupling	4.2.2.2.4	Contingency arrangements	4.2.3.6.3
Axle load parameter	4.2.3.2	Train composition	4.2.2.5
Braking performance	4.2.4.5	Train braking	4.2.2.6
External front and rear lights	4.2.7.1	Train visibility	4.2.2.1
Horn	4.2.7.2	Train audibility	4.2.2.2
External visibility	4.2.9.1.3	Requirements for lineside signal and marker sighting	4.2.2.8
Optical characteristics of the wind-screen	4.2.9.2.2		
Internal lighting	4.2.9.1.8		
Driver's activity control function	4.2.9.3.1	Driver vigilance	4.2.2.9
Recording device	4.2.9.6	Recording of supervision data on-board the train	4.2.3.5.2

4.3.4. *Interface with the Control, command and signalling subsystem*

Table 9

Interface with the Control, command and signalling subsystem

Reference LOC & PAS TSI		Reference CCS TSI	
Parameter	Point	Parameter	Point
Rolling stock characteristics compatible with train detection system based on track circuits	4.2.3.3.1.1	Vehicle geometry Vehicle design Isolating emissions EMC	Specification referenced in Annex A, Index 77 of TSI CCS

▼B

Reference LOC & PAS TSI		Reference CCS TSI	
Parameter	Point	Parameter	Point
Rolling stock characteristics compatible with train detection system based on axle counters	4.2.3.3.1.2	Vehicle geometry Wheel geometry Vehicle design EMC	Specification referenced in Annex A, Index 77 of TSI CCS
Rolling stock characteristics compatible with loop equipment	4.2.3.3.1.3	Vehicle design	Specification referenced in Annex A, Index 77 of TSI CCS
Emergency braking command	4.2.4.4.1	On-board ETCS functionality	4.2.2
Emergency braking performance	4.2.4.5.2	Guaranteed train braking performance and characteristics	4.2.2
Train departing from platform	4.2.5.3	FIS for the train interface	Specification referenced in Annex A, Index 7 of TSI CCS
Door opening	4.2.5.5		
Separation sections	4.2.8.2.9. 8		
Smoke control	4.2.10.4.2		
External visibility	4.2.9.1.3	Visibility of track-side Control-command objects	4.2.15

4.3.5. *Interface with the Telematic application for passengers subsystem*

Table 10

Interface with the Telematic application for passengers subsystem

Reference LOC & PAS TSI		Reference Telematic application for passengers TSI	
Parameter	Point	Parameter	Point
Customer information (PRM)	4.2.5	On board device display	4.2.13.1
Public address system	4.2.5.2	Automatic voice and announcement	4.2.13.2
Customer information (PRM)	4.2.5		

4.4. **Operating rules**

- (1) In light of the essential requirements mentioned in Section 3, the provisions for operation of the rolling stock in the scope of this TSI are described in:

— Clause 4.3.3 ‘Interface with operation subsystem’, which refers to the relevant clauses of the Section 4.2 of this TSI.

▼B

— Clause 4.2.12 ‘Documentation for Operation and Maintenance’

- (2) Operating rules are developed under the railway undertaking safety management system, with consideration of these provisions.
- (3) In particular, operating rules are necessary to ensure that a train stopped on a gradient as specified in clauses 4.2.4.2.1 and 4.2.4.5.5 of this TSI (requirements related to braking) will be immobilised.

The operating rules for use of the public address system, the passenger alarm, the emergency exits, and the operation of the access doors are elaborated with consideration of the relevant provisions of this TSI and of the documentation for operation.

- (4) The technical operating documentation described in clause 4.2.12.4 gives the rolling stock characteristics to be considered in order to define the operating rules in degraded mode.
- (5) Procedures for lifting and rescue are established (including the method and the means of recovering a derailed train or a train that is unable to move normally) with consideration of:
 - the provisions for lifting and jacking described in clauses 4.2.2.6 and 4.2.12.5 of this TSI;
 - the provisions related to the braking system for rescue described in clauses 4.2.4.10 and 4.2.12.6 of this TSI.
- (6) The safety rules for trackside workers or passengers on platforms are developed by the entity(ies) responsible for fixed installations with consideration of the relevant provisions of this TSI and of the technical documentation (e.g. impact of speed).

4.5. **Maintenance rules**

- (1) In light of the essential requirements mentioned in Section 3, the provisions for maintenance of the rolling stock in the scope of this TSI:
 - Clause 4.2.11 ‘Servicing’
 - Clause 4.2.12 ‘Documentation for Operation and Maintenance’.
- (2) Other provisions in the Section 4.2 (clauses 4.2.3.4 and 4.2.3.5) specify for particular characteristics the limit values that have to be verified during maintenance activities.
- (3) From the information mentioned above and provided in the clause 4.2, the appropriate tolerances and intervals to ensure compliance with the essential requirements throughout the lifetime of the rolling stock are defined at maintenance operational level (not in the scope of the assessment against this TSI); this activity includes:
 - The definition of the in-service values where they are not specified in this TSI, or where operating conditions allow the use of different in-service limit values than those specified in this TSI.

▼B

— The justification of the in-service values, by providing the equivalent information to those required in clause 4.2.12.3.1 ‘The maintenance design justification file’.

- (4) On the basis of the information mentioned above in this clause, a maintenance plan is defined at maintenance operational level (not in the scope of the assessment against this TSI), consisting in a structured set of maintenance tasks that include the activities, tests and procedures, means, maintenance criteria, periodicity, working time required to carry out the maintenance tasks.

4.6. Professional competencies

- (1) The professional competencies of staff required for the operation of the rolling stock in the scope of this TSI are not set out in this TSI.
- (2) They are partly covered by the TSI OPE and Directive 2007/59/EC of the European Parliament and of the Council ⁽¹⁾.

4.7. Health and safety conditions

- (1) The provisions for health and safety of staff required for the operation and maintenance of the rolling stock in the scope of this TSI are covered by the essential requirements Nos 1.1, 1.3, 2.5.1, 2.6.1 (as numbered in Directive 2008/57/EC); the table in Section 3.2 mentions the technical clauses of this TSI in relation to these essential requirements.
- (2) In particular, the following provisions of Section 4.2 specify provisions for health and safety of staff:
- Clause 4.2.2.2.5: Staff access for coupling and uncoupling.
 - Clause 4.2.2.5: Passive safety.
 - Clause 4.2.2.8: Staff and freight access doors.
 - Clause 4.2.6.2.1: Slipstream effects on workers at trackside.
 - Clause 4.2.7.2.2: Warning horn sound pressure.
 - Clause 4.2.8.4: Protection against electrical hazards.
 - Clause 4.2.9: Driver's cab.
 - Clause 4.2.10: Fire safety and evacuation.

4.8. European register of authorised types of vehicles

- (1) The characteristics of the rolling stock that must be recorded in the ‘European register of authorised types of vehicles’ are listed in Commission Implementing Decision 2011/665/EU of 4 October 2011 on the European register of authorised types of railway vehicles ⁽²⁾.

⁽¹⁾ Directive 2007/59/EC of the European Parliament and of the Council of 23 October 2007 on the certification of train drivers operating locomotives and trains on the railway system in the Community (OJ L 315, 3.12.2007, p. 51).

⁽²⁾ Commission Implementing Decision 2011/665/EU of 4 October 2011 on the European register of authorised types of railway vehicles (OJ L 264, 8.10.2011, p. 32).

▼B

- (2) In accordance with Annex II of this decision on the European register and with Article 34(2a) of Directive 2008/57/EC, the values to be recorded for the parameters related to the technical characteristics of the rolling stock shall be those of the technical documentation accompanying the type examination certificate. Therefore, this TSI requires that the relevant characteristics are recorded in the technical documentation defined in the clause 4.2.12.
- (3) In accordance with Article 5 of the Decision referred to in the above point (1) of this clause 4.8, its application guide includes for each parameter a reference to the clauses of the technical specifications for interoperability that state the requirements for this parameter.

5. INTEROPERABILITY CONSTITUENTS

5.1. Definition

- (1) According to Article 2(f) of Directive 2008/57/EC, the interoperability constituents are ‘any elementary component, group of components, subassembly or complete assembly of equipment incorporated or intended to be incorporated into a subsystem upon which the interoperability of the rail system depends directly or indirectly.’
- (2) The concept of a ‘constituent’ covers both tangible objects and intangible objects such as software.
- (3) Interoperability constituents (IC) described in Section 5.3 below are constituents:
 - Whose specification refers to a requirement defined in Section 4.2 of this TSI. The reference to the relevant clause of the Section 4.2 is given in Section 5.3; it defines how the interoperability of the rail system depends on the particular constituent.

When a requirement is identified in Section 5.3 as being assessed at IC level, an assessment for the same requirement at sub-system level is not required.

 - Whose specification may need additional requirements, such as interface requirements; these additional requirements are also specified in Section 5.3.
 - And whose assessment procedure, independently of the related subsystem is described in Section 6.1.
- (4) The area of use of an interoperability constituent shall be stated and demonstrated as described for each of them in Section 5.3.

5.2. Innovative solution

- (1) As stated in Article 10, innovative solutions may require new specification and/or new assessment methods. Such specifications and assessment methods shall be developed by the process described in clause 6.1.5 whenever an innovative solution is envisaged for an interoperability constituent.

▼ B**5.3. Interoperability constituent specification**

The interoperability constituents are listed and specified below:

5.3.1. Automatic centre buffer coupler

An automatic coupler shall be designed and assessed for an area of use defined by:

- (1) The type of end coupling (mechanical and pneumatic interface of the head);

The 'type 10' automatic coupler shall be compliant with the specification referenced in Appendix J-1, index 66.

Note: other types of automatic couplers than type 10 are not considered as an IC (specification not publicly available).

- (2) The tensile and compressive forces it is capable of withstanding;
- (3) These characteristics shall be assessed at IC level.

5.3.2. Manual end coupling

A manual end coupling shall be designed and assessed for an area of use defined by:

- (1) The type of end coupling (mechanical interface).

The 'UIC type' shall be composed of buffer, draw gear and screw coupling system complying with the requirements of parts related to passenger coaches of the specification referenced in Appendix J-1, index 67 and the specification referenced in Appendix J-1, index 68; units other than coaches with manual coupling systems shall be fitted with a buffer, draw gear and screw coupling system complying with the relevant parts of the specification referenced in Appendix J-1, index 67 and the specification referenced in Appendix J-1, index 68 respectively.

Note: other types of manual end coupling are not considered as an IC (specification not publicly available).

- (2) The tensile and compressive forces it is capable of withstanding.
- (3) These characteristics shall be assessed at IC level.

5.3.3. Rescue couplers

A rescue coupler shall be designed and assessed for an area of use defined by:

- (1) The type of end coupling it is capable of being interfaced with;

The rescue coupler to be interfaced with the 'type 10' automatic coupler shall be compliant with the specification referenced in Appendix J-1, index 69.

Note: other types of rescue coupler are not considered as an IC (specification not publicly available)

- (2) The tensile and compressive forces it is capable of withstanding.
- (3) The way it is intended to be installed on the rescuing unit.

▼B

- (4) These characteristics and the requirements expressed in clause 4.2.2.2.4 of this TSI shall be assessed at IC level.

5.3.4. *Wheels*

A wheel shall be designed and assessed for an area of use defined by:

- (1) Geometrical characteristics: nominal tread diameter.
- (2) Mechanical characteristics: maximum vertical static force and maximum speed.
- (3) Thermo mechanical characteristics: maximum braking energy.
- (4) A wheel shall comply with the requirements on geometrical, mechanical and thermo mechanical characteristics defined in clause 4.2.3.5.2.2; these requirements shall be assessed at IC level.

5.3.5. *WSP (wheel slide protection system)*

A IC 'WSP system' shall be designed and assessed for an area of use defined by:

- (1) A brake system of pneumatic type.

Note: the WSP is not considered as an IC for other types of brake system such as hydraulic, dynamic and mixed braking systems, and this clause does not apply in that case.

- (2) The maximum operating speed.
- (3) A WSP system shall comply with the requirements related to the wheel slide protection system performance expressed in clause 4.2.4.6.2 of this TSI.

The wheel rotation monitoring system may be included as an option.

5.3.6. *Head lamps*

- (1) A head lamp is designed and assessed without any limitation concerning its area of use.
- (2) A head lamp shall comply with requirements concerning the colour and the luminous intensity defined in clause 4.2.7.1.1. These requirements shall be assessed at IC level.

5.3.7. *Marker lamps*

- (1) A marker lamp is designed and assessed without any limitation concerning its area of use.
- (2) A marker lamp shall comply with requirements concerning the colour and the luminous intensity defined in clause 4.2.7.1.2. These requirements shall be assessed at IC level.

5.3.8. *Tail lamps*

- (1) A tail lamp shall be designed and assessed for an area of use: fixed lamp or portable lamp.

▼B

- (2) A tail lamp shall comply with the requirements concerning the colour and the luminous intensity defined in clause 4.2.7.1.3. These requirements shall be assessed at IC level.
- (3) For portable tail lamps, the interface for attachment on the vehicle shall be in accordance with the Appendix E of the TSI 'freight wagons'.

5.3.9. *Horns*

- (1) A horn shall be designed and assessed for an area of use defined by its sound pressure level on a reference vehicle (or reference integration); this characteristic may be affected by the integration of the horn in a particular vehicle.
- (2) A horn shall comply with the requirements concerning the soundings of signals defined in clause 4.2.7.2.1. These requirements shall be assessed at IC level.

5.3.10. *Pantograph*

A pantograph shall be designed and assessed for an area of use defined by:

- (1) The type of voltage system(s), as defined in clause 4.2.8.2.1.

In case it is designed for different voltage systems, the various sets of requirements shall be taken into account.
- (2) One of the 3 pantograph head geometries specified in clause 4.2.8.2.9.2.
- (3) The current capacity, as defined in clause 4.2.8.2.4.
- (4) The maximum current at standstill per contact wire of the overhead contact line for DC systems.

Note: the maximum current at standstill, as defined in clause 4.2.8.2.5., shall be compatible with the value above, considering the characteristics of the overhead contact line (1 or 2 contact wires).

- (5) The maximum operating speed: assessment of the maximum operating speed shall be performed as defined in clause 4.2.8.2.9.6.
- (6) Range of height for dynamic behaviour: standard, and/or for 1 520 mm or 1 524 mm track gauge systems.
- (7) The requirements listed above shall be assessed at IC level.
- (8) The working range in height of pantograph specified in clause 4.2.8.2.9.1.2, the pantograph head geometry specified in clause 4.2.8.2.9.2, the pantograph current capacity specified in clause 4.2.8.2.9.3, the pantograph static contact force specified in clause 4.2.8.2.9.5 and the dynamic behaviour of the pantograph itself specified in clause 4.2.8.2.9.6 shall also be assessed at IC level.

▼B5.3.11. *Contact strips*

- (1) The contact strips are the replaceable parts of the pantograph head which are in contact with the contact wire.

Contact strips shall be designed and assessed for an area of use defined by:

- (2) Their geometry, as defined in clause 4.2.8.2.9.4.1.
- (3) The material of the contact strips, as defined in clause 4.2.8.2.9.4.2.
- (4) The type of voltage system(s), as defined in clause 4.2.8.2.1.
- (5) The current capacity, as defined in clause 4.2.8.2.4.
- (6) The maximum current at standstill for DC systems, as defined in clause 4.2.8.2.5.
- (7) The requirements listed above shall be assessed at IC level.

5.3.12. *Main circuit breaker*

A main circuit breaker shall be designed and assessed for an area of use defined by:

- (1) The type of voltage system(s), as defined in clause 4.2.8.2.1.
- (2) The current capacity, as defined in clause 4.2.8.2.4 (maximum current).
- (3) The requirements listed above shall be assessed at IC level.
- (4) The tripping shall be as specified in the specification referenced in Appendix J-1, index 70 (see clause 4.2.8.2.10 of this TSI); it shall be assessed at the IC level.

5.3.13. *Driver's seat*

- (1) A driver's seat shall be designed and assessed for an area of use defined by the range of possible adjustments in height and longitudinal position.
- (2) A driver's seat shall comply to the requirements specified at component level in the clause 4.2.9.1.5. These requirements shall be assessed at IC level.

5.3.14. *Toilet discharge connection*

- (1) A toilet discharge connection is designed and assessed without any limitation concerning its area of use.
- (2) A toilet discharge connection shall comply with requirements concerning the dimensions as defined in clause 4.2.11.3. These requirements shall be assessed at IC level.

5.3.15. *Inlet connection for water tanks*

- (1) An inlet connection for water tanks is designed and assessed without any limitation concerning its area of use.

▼B

- (2) A inlet connection for water tanks shall comply with requirements concerning the dimensions as defined in clause 4.2.11.5. These requirements shall be assessed at IC level.

6. ASSESSMENT OF CONFORMITY OR SUITABILITY FOR USE AND 'EC' VERIFICATION

- (1) Modules for the procedures for assessment of conformity, suitability for use and EC verification are described in the Commission Decision 2010/713/EU ⁽¹⁾.

6.1. **Interoperability constituents**

6.1.1. *Conformity assessment*

- (1) An EC declaration of conformity or suitability for use, in accordance with Article 13(1) and Annex IV of Directive 2008/57/EC, shall be drawn up by the manufacturer or his authorised representative established in the Union before placing a interoperability constituent on the market.

- (2) The assessment of conformity or suitability for use of an interoperability constituent shall be performed according to the prescribed module(s) of that particular constituent specified in clause 6.1.2 of this TSI.

6.1.2. *Application of modules*

Modules for EC certification of conformity of interoperability constituents:

Module CA	Internal production control
Module CA1	Internal production control plus product verification by individual examination
Module CA2	Internal production control plus product verification at random intervals
Module CB	EC-Type examination
Module CC	Conformity to type based on internal production control
Module CD	Conformity to type based on quality management system of the production process
Module CF	Conformity to type based on product verification
Module CH	Conformity based on full quality management system
Module CH1	Conformity based on full quality management system plus design examination
Module CV	Type validation by in service experience (Suitability for use)

⁽¹⁾ Commission Decision 2010/713/EU of 9 November 2010 on modules for the procedures for assessment of conformity, suitability for use and EC verification to be used in the technical specifications for interoperability adopted under Directive 2008/57/EC of the European Parliament and of the Council (OJ L 319, 4.12.2010, p. 1).

▼B

- (1) The manufacturer or his authorised representative established within the European Union shall choose one of the modules or module combinations indicated in the following table for the constituent to be assessed:

Point	Constituents to be assessed	Module CA	Module CA1 or CA2	Module CB + CC	Module CB + CD	Module CB + CF	Module CH	Module CH1
5.3.1	Automatic centre buffer coupler		X (*)		X	X	X (*)	X
5.3.2	Manual end coupling		X (*)		X	X	X (*)	X
5.3.3	Towing coupler for rescue		X (*)		X	X	X (*)	X
5.3.4	Wheel		X (*)		X	X	X (*)	X
5.3.5	Wheel slide protection system		X (*)		X	X	X (*)	X
5.3.6	Head lamp		X (*)	X	X		X (*)	X
5.3.7	Marker lamp		X (*)	X	X		X (*)	X
5.3.8	Tail lamp		X (*)	X	X		X (*)	X
5.3.9	Horns		X (*)	X	X		X (*)	X
5.3.10	Pantograph		X (*)		X	X	X (*)	X
5.3.11	Pantograph contact strips		X (*)		X	X	X (*)	X
5.3.12	Main circuit breaker		X (*)		X	X	X (*)	X
5.3.13	Driver's seat		X (*)		X	X	X (*)	X
5.3.14	Toilet discharge connection	X		X			X	
5.3.15	Inlet connection for water tanks	X		X			X	

(*) Modules CA1, CA2 or CH may be used only in the case of products manufactured according to a design developed and already used to place products on the market before the entry into force of relevant TSIs applicable to those products, provided that the manufacturer demonstrates to the notified body that design review and type examination were performed for previous applications under comparable conditions, and are in conformity with the requirements of this TSI; this demonstration shall be documented, and is considered as providing the same level of proof as module CB or design examination according to module CH1.

- (2) Where a particular procedure shall be used for the assessment, in addition to the requirements expressed in the clause 4.2 of this TSI, this is specified in the clause 6.1.3 below.

▼B6.1.3. *Particular assessment procedures for interoperability constituents*6.1.3.1. *Wheels (clause 5.3.4)*

- (1) The mechanical characteristics of the wheel shall be proven by mechanical strength calculations, taking into account three load cases: straight track (centred wheelset), curve (flange pressed against the rail), and negotiating of points and crossings (inside surface of flange applied to the rail), as specified in the specification referenced in Appendix J-1, index 71, clauses 7.2.1 and 7.2.2.
- (2) For forged and rolled wheels, the decision criteria are defined in the specification referenced in Appendix J-1, index 71, clause 7.2.3; where the calculation show values beyond the decision criteria, a bench test according to the specification referenced in Appendix J-1, index 71, clause 7.3 is required to be performed to demonstrate compliance.
- (3) Other types of wheels are permitted for vehicles restricted to national use. In that case the decision criteria and the fatigue stress criteria shall be specified in national rules. Those national rules shall be notified by Member States.
- (4) The assumption of the load conditions for the maximum vertical static force shall be explicitly stated in the technical documentation as set out in clause 4.2.12 of this TSI.

Thermo-mechanical behaviour:

- (5) If the wheel is used to brake a unit with blocks acting on the wheel running surface, the wheel shall be thermo mechanically proven by taking into account the maximum braking energy foreseen. The wheel shall be subject to a conformity assessment in accordance with the specification referenced in Appendix J-1, index 71, clause 6 in order to check that the lateral displacement of the rim during braking and the residual stress are within tolerance limits specified utilising the decision criteria specified.

Verification of the wheels:

- (6) A verification procedure shall exist to ensure at the production phase that no defects may detrimentally affect safety due to any change in the mechanical characteristics of the wheels.

The tensile strength of the material in the wheel, the hardness of the running surface, the fracture toughness, the resistance to impact, the material characteristics and the material cleanliness shall be verified.

The verification procedure shall specify the batch sampling used for each characteristic to be verified.

- (7) Other conformity assessment method for wheels is allowed under the same conditions as for wheelsets; these conditions are described in clause 6.2.3.7.
- (8) In case of innovative design for which the manufacturer has no sufficient return of experience, the wheel should be subject to an assessment of suitability for use (module CV; see also clause 6.1.6).

▼B

- 6.1.3.2. Wheel slide protection system (clause 5.3.5)
- (1) The wheel slide protection system shall be verified according to the methodology defined in the specification referenced in Appendix J-1, index 72; when reference is made to the clause 6.2 of the same specification 'overview of required test programmes', only the clause 6.2.3 applies, and it applies to all WSP systems.
 - (2) In case of innovative design for which the manufacturer has no sufficient return of experience, the wheel slide protection system should be subject to an assessment of suitability for use (module CV; see also clause 6.1.6).
- 6.1.3.3. Headlamps (clause 5.3.6)
- (1) The colour of headlamps shall be tested in accordance with the specification referenced in Appendix J-1, index 73, clause 6.3.
 - (2) The luminous intensity of headlamps shall be tested in accordance with the specification referenced in Appendix J-1, index 73, clause 6.4.
- 6.1.3.4. Marker lamps (clause 5.3.7)
- (1) The colour of marker lamps and the spectral radiation distribution of light from marker lamps shall be tested in accordance with the specification referenced in Appendix J-1, index 74, clause 6.3.
 - (2) The luminous intensity of marker lamps shall be tested in accordance with the specification referenced in Appendix J-1, index 74, clause 6.4.
- 6.1.3.5. Tail lamps (clause 5.3.8)
- (1) The colour of tail lamps shall be tested in accordance with the specification referenced in Appendix J-1, index 75, clause 6.3.
 - (2) The luminous intensity of tail lamps shall be tested in accordance with the specification referenced in Appendix J-1, index 75, clause 6.4.
- 6.1.3.6. Horn (clause 5.3.9)
- (1) Soundings of the warning horn shall be measured and verified in accordance with the specification referenced in Appendix J-1, index 76, clause 6.
 - (2) Sound pressure levels of the warning horn on a reference vehicle shall be measured and verified in accordance with the specification referenced in Appendix J-1, index 76, clause 6.
- 6.1.3.7. Pantograph (clause 5.3.10)
- (1) For pantographs for DC systems, the maximum current at standstill per contact wire shall be verified in the following conditions:
 - the pantograph shall be in contact with 1 copper contact wire.
 - the pantograph shall apply a static contact force as defined in the specification referenced in Appendix J-1, index 77.
 - and the temperature of the contact point monitored continuously during a test of 30 minutes shall not exceed the values given in the specification referenced in Appendix J-1, index 78.

▼ B

- (2) For all pantographs, the static contact force shall be verified in accordance with the specification referenced in Appendix J-1, index 79.
- (3) The dynamic behaviour of the pantograph regarding current collection shall be assessed by simulation according to the specification referenced in Appendix J-1, index 80.

The simulations shall be made using at least two different types of overhead contact line; data for simulation shall correspond to sections of lines recorded as TSI compliant in the register of infrastructure (EC declaration of conformity, or declaration according to Commission Recommendation 2011/622/EU ⁽¹⁾) for the appropriate speed and supply system, up to the design speed of the proposed Interoperability Constituent pantograph.

It is permitted to perform the simulation using types of overhead contact line that are under the process of IC certification or declaration according to Recommendation 2011/622/EU, provided that they fulfil the other requirements of ENE TSI. The simulated current collection quality shall be in accordance with clause 4.2.8.2.9.6 for uplift, mean contact force and standard deviation for each of the overhead contact lines.

If the simulation results are acceptable, a site dynamic test shall be made using a representative section of one of the two types of overhead contact line used in the simulation.

The interaction characteristics shall be measured in accordance with the specification referenced in Appendix J-1, index 81.

The tested pantograph shall be mounted on a rolling stock producing a mean contact force within the upper and lower limits as required by clause 4.2.8.2.9.6 up to the design speed of the pantograph. The tests shall be conducted in both directions of travel.

For pantographs intended to be operated on the 1 435 mm and 1 668 mm track gauge systems, the tests shall include track sections with low contact wire height (defined as between 5,0 to 5,3 m) and track sections with high contact wire height (defined as between 5,5 to 5,75 m).

For pantographs intended to be operated on the 1 520 mm and 1 524 mm track gauge systems, the tests shall include track sections with contact wire height between 6,0 to 6,3 m.

The tests shall be performed for a minimum of 3 speed increments up to and including the design speed of the tested pantograph.

The interval between successive tests shall be no greater than 50 km/h.

The measured current collection quality shall be in accordance with clause 4.2.8.2.9.6 for uplift, and either mean contact force and standard deviation or percentage of arcing.

⁽¹⁾ Commission Recommendation of 20 September 2011 on the procedure demonstrating the level of compliance of existing railway lines with the basic parameters of the technical specifications for interoperability (OJ L 243, 21.9.2011, p. 23).

▼ B

If all the assessments above are passed successfully, the tested pantograph design shall be considered as compliant to the TSI regarding quality of current collection.

For the use of a pantograph holding an EC declaration of verification on various designs of rolling stock, additional tests required at rolling stock level regarding quality of current collection are specified in clause 6.2.3.20.

6.1.3.8. *Contact strips (clause 5.3.11)*

- (1) Contact strips shall be verified as specified in the specification referenced in Appendix J-1, index 82.
- (2) Contact strips, being replaceable parts of the pantograph head, shall be verified once at the same time as a pantograph (see clause 6.1.3.7) regarding the quality of current collection.
- (3) In case of use of a material for which the manufacturer as no sufficient return of experience, the contact strip should be subject to an assessment of suitability for use (module CV; see also clause 6.1.6).

6.1.4. *Project phases where assessment is required*

- (1) It is detailed in Appendix H of this TSI in which phases of the project an assessment shall be done for the requirements applicable to the interoperability constituents:

— Design and development phase:

— Design review and/or design examination.

— Type test: test to verify the design, if and as defined in the Section 4.2.

— Production phase: routine test to verify the conformity of production.

The entity in charge of the assessment of the routine tests is determined according to the assessment module chosen.

- (2) Annex H is structured according to Section 4.2; the requirements and their assessment applicable to the interoperability constituents are identified in Section 5.3 by reference to certain clauses of Section 4.2; where relevant, a reference to a sub-clause of clause 6.1.3 above is also given.

6.1.5. *Innovative solutions*

- (1) If an innovative solution (as defined in article 10) is proposed for an interoperability constituent, the manufacturer or his authorised representative established within the European Union shall apply the procedure described in article 10.

6.1.6. *Assessment of suitability for use*

- (1) Assessment of suitability for use according to the type validation of in service experience procedure (module CV) may be part of the assessment procedure for the following interoperability constituents in case the manufacturer has no sufficient return of experience for the proposed design:

— Wheels (see clause 6.1.3.1).

▼B

— Wheel slide protection system (see clause 6.1.3.2).

— Contact strips (see clause 6.1.3.8).

- (2) Prior to commencing in service tests, a suitable module (CB or CH1) shall be used to certify the design of the constituent.
- (3) The in service tests shall be organised on proposal from the manufacturer, who has to obtain an agreement with a railway undertaking for its contribution to such assessment.

6.2. Rolling stock subsystem

6.2.1. EC verification (general)

- (1) The EC verification procedures to be applied to the rolling stock subsystem are described in Article 18 and Annex VI of Directive 2008/57/EC.
- (2) The EC verification procedure of a rolling stock unit shall be performed according to the prescribed modules(s) specified in clause 6.2.2 of this TSI.
- (3) When a first step assessment covering the design stage or the design and production stages is applied for by the applicant, the notified body of his choice shall issue the Intermediate Statement Verification (ISV) and the EC declaration of Intermediate Sub-system conformity shall be drawn up.

6.2.2. Application of modules

Modules for the EC verification of subsystems:

Module SB	EC-Type Examination
Module SD	EC verification based on quality management system of the production process
Module SF	EC verification based on product verification
Module SH1	EC verification based on full quality management system plus design examination

- (1) The applicant shall choose one of the following combinations of modules:

(SB + SD) or (SB + SF) or (SH1) for each concerned subsystem (or part of subsystem).

The assessment shall then be performed according to the combination of modules chosen.

- (2) Where several EC verifications (e.g. against several TSIs addressing the same sub-system) require verification based on the same production assessment (module SD or SF), it is allowed to combine several SB module assessments with one production module assessment (SD or SF). In this case, ISVs shall be issued for the design and development phases according to module SB.
- (3) The validity of the type or design examination certificate shall be indicated in accordance with the provisions for phase B of clause 7.1.3 'Rules related to EC verification', of this TSI.

▼B

- (4) Where a particular procedure shall be used for the assessment, in addition to the requirements expressed in the clause 4.2 of this TSI, this is specified in the clause 6.2.3 below.

6.2.3. *Particular assessment procedures for subsystems*

6.2.3.1. Load conditions and weighed mass (clause 4.2.2.10)

- (1) Weighed mass shall be measured, for a load condition corresponding to 'design mass in working order' with the exception of consumables for which there is no imposition (for example 'dead mass' is acceptable).
- (2) It is permissible to derive the other load conditions by calculation.
- (3) Where a vehicle is declared as conformant to a type (in accordance with clauses 6.2.2 and 7.1.3 of this TSI):

— the weighed total vehicle mass in the load condition 'design mass in working order' shall not exceed by more than 3 % the declared total vehicle mass for that type which is reported in the type or design examination certificate of 'EC' verification and in the technical documentation described in clause 4.2.12.

— additionally, for unit of maximum design speed higher than or equal to 250 km/h the mass per axle for the load condition 'design mass under normal payload' shall not exceed by more than 4 % the declared mass per axle for the same load condition.

6.2.3.2. Wheel load (clause 4.2.3.2.2)

- (1) The wheel load shall be measured considering the load condition 'design mass in working order' (with same exception as in clause 6.2.3.1 above).

6.2.3.3. Safety against derailment running on twisted track (Clause 4.2.3.4.1)

- (1) The demonstration of conformity shall be carried out in accordance with one of the methods specified in the specification referenced in Appendix J-1, index 83 as amended by the technical document referenced in Appendix J.2, index 2.
- (2) For units intended to be operated on 1 520 mm system, alternative methods for conformity assessment are allowed.

6.2.3.4. Running dynamic behaviour — technical requirements (Clause 4.2.3.4.2 a)

- (1) For units designed to be operated on 1 435 mm or 1 524 mm or 1 668 mm system, the demonstration of conformity shall be carried out in accordance with the specification referenced in Appendix J-1, index 84, clause 5.

The parameters described in clauses 4.2.3.4.2.1 and 4.2.3.4.2.2 shall be assessed using criteria defined in the specification referenced in Appendix J-1, index 84.

The conditions for the assessment in accordance with the specification referenced in Appendix J-1, index 84 shall be amended as per technical document referenced in Appendix J-2, index 2.

▼B

6.2.3.5. Conformity assessment for safety requirements

The demonstration of compliance with the safety requirements expressed in the clause 4.2 shall be performed as follows:

- (1) The scope of this assessment shall be strictly limited to the rolling stock design, considering that operation, test and maintenance are performed according to the rules defined by the applicant (as described in the technical file).

Notes:

— When defining the test and maintenance requirements, the safety level to be met has to be taken into account by the applicant (consistency); the demonstration of compliance covers also test and maintenance requirements.

— Other sub-systems and human factors (errors) shall not be considered.

- (2) All assumptions considered for the mission profile shall be clearly documented in the demonstration.
- (3) The compliance with the safety requirements that are specified in clauses 4.2.3.4.2, 4.2.4.2.2, 4.2.5.3.5, 4.2.5.5.8 and 4.2.5.5.9 in terms of level of severity/consequences associated to hazardous failure scenarios shall be demonstrated by one of the two following methods:

1. Application of a harmonised risk acceptance criterion associated to the severity specified in the clause 4.2 (e.g. 'fatalities' for emergency braking).

The applicant may choose to use this method, provided that there is an available harmonized risk acceptance criterion defined in the CSM on Risk Assessment and its amendments (Commission Regulation (EC) No 352/2009⁽¹⁾).

The applicant shall demonstrate compliance with the harmonised criterion by applying Annex I-3 of the CSM on RA. The following principles (and their combinations) may be used for the demonstration: similarity with reference system(s); application of codes of practice; application of an explicit risk estimation (e.g. probabilistic approach).

The applicant shall designate the body for the assessment of the demonstration he will provide: the notified body selected for the RST sub-system or an assessment body as defined in the CSM on RA.

The demonstration shall be recognised in all Member States; or

2. Application of a risk evaluation and assessment in accordance with the CSM on RA, in order to define the risk acceptance criterion to be used, and demonstrate compliance to this criterion.

⁽¹⁾ Commission Regulation (EC) No 352/2009 of 24 April 2009 on the adoption of a common safety method on risk evaluation and assessment as referred to in Article 6(3)(a) of Directive 2004/49/EC of the European Parliament and of the Council (OJ L 108, 29.4.2009, p. 4).

▼B

The applicant may choose to use this method in any case.

The applicant shall designate the assessment body for the assessment of the demonstration he will provide, as defined in the CSM on RA.

A safety assessment report shall be provided in compliance with the requirements defined in the CSM on RA and its amendments.

The safety assessment report shall be taken into account by the National Safety Authority in the concerned Member State, in accordance with Section 2.5.6 of Annex I and Article 15(2) of the CSM on RA.

In the case of additional authorisations for placing in service of vehicles, Article 15 (5) of the CSM on RA applies for the recognition of the safety assessment report in other Member States.

- (4) For each TSI clause listed in point (3) above, the relevant documents accompanying the EC declaration of verification (e.g. EC certificate issued by the notified body or safety assessment report) shall explicitly mention the 'used method' ('1' or '2'); in case of method '2', they shall also mention the 'used risk acceptance criterion'.

6.2.3.6. Design values for new wheel profiles (Clause 4.2.3.4.3.1)

- (1) For units designed to be operated on 1 435 mm track gauge system, the wheel profile and the distance between active faces of the wheels (Dimension SR in Figure 1, § 4.2.3.5.2.1) shall be selected to ensure that the equivalent conicity limit set out in Table 11 below is not exceeded when the designed wheelset is combined with each of the sample of track parameters as specified in Table 12 below.

The evaluation of the equivalent conicity is set out in the technical document referenced in Appendix J-2, index 2.

Table 11

Equivalent conicity design limit values

Maximum vehicle operating speed (km/h)	Equivalent conicity limit values	Test conditions (see Table 12)
≤ 60	N/A	N/A
> 60 and < 190	0,30	All
≥ 190 and ≤ 230	0,25	1, 2, 3, 4, 5 and 6
> 230 and ≤ 280	0,20	1, 2, 3, 4, 5 and 6
> 280 and ≤ 300	0,10	1, 3, 5 and 6
> 300	0,10	1 and 3



Table 12.

Track test conditions for equivalent conicity representative of the network. All rail sections defined in the specification referenced in Appendix J-1, index 85.

Test condition no.	Rail head profile	Rail inclination	Track gauge
1	rail section 60 E 1	1 in 20	1 435 mm
2	rail section 60 E 1	1 in 40	1 435 mm
3	rail section 60 E 1	1 in 20	1 437 mm
4	rail section 60 E 1	1 in 40	1 437 mm
5	rail section 60 E 2	1 in 40	1 435 mm
6	rail section 60 E 2	1 in 40	1 437 mm
7	rail section 54 E1	1 in 20	1 435 mm
8	rail section 54 E1	1 in 40	1 435 mm
9	rail section 54 E1	1 in 20	1 437 mm
10	rail section 54 E1	1 in 40	1 437 mm

The requirements of this clause are deemed to have been met by wheelsets having unworn S1002 or GV 1/40 profiles, as defined in the specification referenced in Appendix J-1, index 86 with spacing of active faces between 1 420 mm and 1 426 mm.

- (2) For units designed to be operated on 1 524 mm track gauge system, the wheel profile and the distance between active faces of the wheels shall be selected with the following inputs:

Table 13

Equivalent conicity design limit values

Maximum vehicle operating speed (km/h)	Equivalent conicity limit values	Test conditions (see Table 14)
≤ 60	N/A	N/A
> 60 and ≤ 190	0,30	1, 2, 3, 4, 5 and 6
> 190 and ≤ 230	0,25	1, 2, 3 and 4
> 230 and ≤ 280	0,20	1, 2, 3 and 4
> 280 and ≤ 300	0,10	3, 4, 7 and 8
> 300	0,10	7 and 8

Table 14

Track test conditions for equivalent conicity. All rail sections defined in the specification referenced in Appendix J-1, index 85

Test condition no.	Rail head profile	Rail inclination	Track gauge
1	rail section 60 E 1	1 in 40	1 524 mm
2	rail section 60 E 1	1 in 40	1 526 mm

▼B

Test condition no.	Rail head profile	Rail inclination	Track gauge
3	rail section 60 E 2	1 in 40	1 524 mm
4	rail section 60 E 2	1 in 40	1 526 mm
5	rail section 54 E1	1 in 40	1 524 mm
6	rail section 54 E1	1 in 40	1 526 mm
7	rail section 60 E 1	1 in 20	1 524 mm
8	rail section 60 E 1	1 in 20	1 526 mm

The requirements of this clause are deemed to have been met by wheelsets having unworn S1002 or GV 1/40 profiles, as defined in the specification referenced in Appendix J-1, index 86, with spacing of active faces distance 1 510.

- (3) For units designed to be operated on 1 668 mm track gauge system, equivalent conicity limits set in the Table 15 shall not be exceeded when the designed wheelset is modelled passing over the representative sample of track test conditions as specified in Table 16:

Table 15

Equivalent conicity design limit values

Maximum vehicle operating speed (km/h)	Equivalent conicity limit values	Test conditions (see Table 16)
≤ 60	N/A	N/A
> 60 and < 190	0,30	All
≥ 190 and ≤ 230	0,25	1 and 2
> 230 and ≤ 280	0,20	1 and 2
> 280 and ≤ 300	0,10	1 and 2
> 300	0,10	1 and 2

Table 16

Track test conditions for equivalent conicity. All rail sections defined in the specification referenced in Appendix J-1, index 85

Test condition No.	Rail head profile	Rail inclination	Track gauge
1	Rail section 60 E 1	1 in 20	1 668 mm
2	Rail section 60 E 1	1 in 20	1 670 mm
3	Rail section 54 E1	1 in 20	1 668 mm
4	Rail section 54 E1	1 in 20	1 670 mm

The requirements of this clause are deemed to have been met by wheelsets having unworn S1002 or GV 1/40 profiles, as defined in the specification referenced in Appendix J-1, index 86 with spacing of active faces between 1 653 mm and 1 659 mm.

▼B

6.2.3.7. Mechanical and geometric characteristics of wheelsets (clause 4.2.3.5.2.1)

Wheelset:

- (1) The demonstration of compliance for the assembly shall be based on the specification referenced in Appendix J-1, index 87, which defines limit values for the axial force, and the associated verification tests.

Axles:

- (2) The demonstration of compliance for mechanical resistance and fatigue characteristics of the axle shall be in accordance with the specification referenced in Appendix J-1, index 88, clauses 4, 5 and 6 for non-powered axles, or the specification referenced in Appendix J-1, index 89, clauses 4, 5 and 6 for powered axles.

The decision criteria for the permissible stress is specified in the specification referenced in Appendix J-1, index 88, clause 7 for non-powered axles, or the specification referenced in Appendix J-1, index 89, clause 7 for powered axles.

- (3) The assumption of the load conditions for the calculations shall be explicitly stated in the technical documentation as set out in clause 4.2.12 of this TSI.

Verification of the axles:

- (4) A verification procedure shall exist to ensure at the production phase that no defects may detrimentally affect safety due to any change in the mechanical characteristics of the axles.
- (5) The tensile strength of the material in the axle, the resistance to impact, the surface integrity, the material characteristics and the material cleanliness shall be verified.

The verification procedure shall specify the batch sampling used for each characteristic to be verified.

Axle boxes/bearings:

- (6) The demonstration of compliance for mechanical resistance and fatigue characteristics of the rolling bearing shall be in accordance with the specification referenced in Appendix J-1, index 90.
- (7) Other conformity assessment method applicable to wheelsets, axles and wheels where the EN standards do not cover the proposed technical solution:

It is permitted to use other standards where the EN standards do not cover the proposed technical solution; in that case the notified body shall verify that the alternative standards form part of a technically consistent set of standards applicable to the design, construction and testing of the wheelsets, containing specific requirements for wheelset, wheels, axles and axle bearings covering:

- wheelset assembly,
- mechanical resistance,
- fatigue characteristics,
- permissible stress limits,

▼B

— thermomechanical characteristics.

Only standards that are publicly available can be referred to in the demonstration required above.

- (8) Particular case of wheelsets, axles and axle boxes/bearings manufactured according to an existing design:

In the case of products manufactured according to a design developed and already used to place products on the market before the entry into force of relevant TSIs applicable to those products, the applicant is allowed to deviate from the conformity assessment procedure above, and to demonstrate conformity with the requirements of this TSI by referring to design review and type examination performed for previous applications under comparable conditions; this demonstration shall be documented, and is considered as providing the same level of proof as module SB or design examination according to module SH1.

6.2.3.8. Emergency braking (clause 4.2.4.5.2)

- (1) The braking performance which is subject to a test is the stopping distance as defined in the specification referenced in Appendix J-1, index 91. The deceleration is evaluated from the stopping distance.
- (2) Tests shall be carried out on dry rails at the following initial speeds (if lower than the maximum design speed): 30 km/h; 100 km/h; 120 km/h; 140 km/h; 160 km/h; 200 km/h; in steps not greater than 40 km/h from 200 km/h to maximum design speed of the unit.
- (3) Tests shall be carried out for the load conditions of the unit 'design mass in working order' 'design mass under normal payload' and 'maximum braking load' (as defined in clauses 4.2.2.10 and 4.2.4.5.2).

Where 2 of the load conditions above lead to similar brake test conditions according to relevant EN standards or normative documents, it is allowed to reduce the number of tests conditions from 3 to 2.

- (4) Test results shall be evaluated by a methodology that takes into account the following aspects:

— correction of the raw data,

— repeatability of the test: in order to validate a test result, the test is repeated several times; the absolute difference between results and the standard deviation are evaluated.

6.2.3.9. Service braking (clause 4.2.4.5.3)

- (1) The maximum service braking performance which is subject to a test is the stopping distance as defined in the specification referenced in Appendix J-1, index 92. The deceleration is evaluated from the stopping distance.
- (2) Tests shall be carried out on dry rail at the initial speed equal to the maximum design speed of the unit, the load condition of the unit being one of those defined in the clause 4.2.4.5.2.

▼B

- (3) Test results shall be evaluated by a methodology that takes into account the following aspects:

- correction of the raw data,
- repeatability of the test: in order to validate a test result, the test is repeated several times; the absolute difference between results and the standard deviation are evaluated.

6.2.3.10. Wheel slide protection system (clause 4.2.4.6.2)

- (1) If a unit is equipped with a WSP, a test of the unit in low adhesion conditions shall be carried out according to the specification referenced in Appendix J-1, index 93, in order to validate the performance of the WSP system (maximum extension of the stopping distance compared to stopping distance on dry rail) when integrated in the unit.

6.2.3.11. Sanitary systems (clause 4.2.5.1)

- (1) In case the sanitary system allows the release of fluids to the environment (e.g. on the tracks), the assessment of conformity may be based on previous in-service testing when the following conditions are met:

- The results of the in service tests were obtained on types of equipment which have an identical treatment method.
- The conditions of test are similar as the ones that may be assumed for the unit under assessment, with regard to loading volumes, environmental conditions, and all other parameters which will influence the efficiency and effectiveness of the treatment process.

If suitable in-service testing results are lacking, type tests shall be performed.

6.2.3.12. Internal air quality (clause 4.2.5.8 and clause 4.2.9.1.7)

- (1) Conformity assessment of the CO₂-levels is permitted to be established by calculation of fresh air ventilation volumes assuming an outside air quality containing 400 ppm CO₂ and an emission of 32 grams of CO₂ per passenger per hour. The number of passengers to be taken into account shall be derived from the occupation under the load condition 'design mass under normal payload', as stipulated in clause 4.2.2.10 of this TSI.

6.2.3.13. Slipstream effects on passengers on platform and on workers trackside (clause 4.2.6.2.1)

- (1) Conformity shall be assessed on the basis of full-scale tests on straight track. The vertical distance between the top of the rail and the surrounding ground level up to 3 m from the track centre shall be within the range of 0,50 m and 1,50 m below the top of the rail. The values of $u_{2\sigma}$ are the upper bound of the 2 σ confidence interval of the maximum resultant induced air speeds in the horizontal plane at the above measurements positions. These shall be obtained from at least 20 independent and comparable test samples with ambient wind speeds less than or equal to 2 m/s.

▼ B

$U_{2\sigma}$ is given by:

$$U_{2\sigma} = \bar{U} + 2\sigma$$

Where:

\bar{U} mean value of all air speed measurements U_i , for i train passages, where $i \geq 20$

σ standard deviation of all air speed measurements U_i , for i train passages, where $i \geq 20$

- (2) The measurements shall consist of the time period starting 4s second before the passing of the first axle and continue until 10 s after the last axle has passed.

The tested train speed $v_{tr,test}$.

$V_{tr,test} = v_{tr,ref}$, or

$v_{tr,test} = 250$ km/h or $v_{tr,max}$ whichever is lower.

At least 50 % of the train passages shall be within ± 5 % of the $v_{tr,test}$ and all train passages shall be within ± 10 % of the $v_{tr,test}$.

- (3) All valid measurements shall be used in the post processing of the data.

Each measurement $U_{m,i}$ shall be corrected:

$$U_i = U_{m,i} * V_{tr,ref}/V_{tr,i}$$

where $v_{tr,i}$ is the train speed for test run i and $v_{tr,ref}$ is the reference train speed.

- (4) The test site shall be free from any objects providing from sheltering against the train-induced air flow.
- (5) Meteorological conditions during tests shall be observed as per the specification referenced in Appendix J-1, index 94.
- (6) Sensors, accuracy, selection of valid data and processing of the data shall be in accordance with the specification referenced in Appendix J-1, index 94.

6.2.3.14. Head pressure pulse (clause 4.2.6.2.2)

- (1) Conformity shall be assessed on the basis of full-scale tests under conditions specified in the specification referenced in Appendix J-1, index 95, clause 5.5.2. Alternatively conformity may be assessed by means of either validated Computational Fluid Dynamics (CFD) simulations as described in the specification referenced in Appendix J-1, index 95, clause 5.3 or as an additional alternative conformity is permitted to be assessed by moving model tests as specified in the specification referenced in Appendix J-1, index 95, clause 5.4.3.

6.2.3.15. Maximum pressure variations in tunnels (clause 4.2.6.2.3)

- (1) Conformity shall be proven on the basis of full-scale tests, carried out at reference speed or at a higher speed in a tunnel with a cross sectional area as close to the reference case as possible. Transfer to the reference condition shall be done with validated simulation software.

▼B

- (2) When assessing conformity of whole trains or trainsets, assessment shall be made with the maximum length of the train or coupled trainsets up to 400 m.
- (3) When assessing conformity of locomotives or driving coaches, assessment shall be done on a basis of two arbitrary train compositions of minimum length 150 m, one with a leading locomotive or driving coach (to check the Δp_N) and one with a locomotive or a driving coach at the end (to check Δp_T). Δp_{Fr} is set to 1 250 Pa (for trains with $v_{tr,max} < 250$ km/h) or to 1 400 Pa (for trains with $v_{tr,max} \geq 250$ km/h).
- (4) When assessing conformity of coaches only, assessment shall be done on the basis of one 400 m long train.

Δp_N is set to 1 750 Pa and Δp_T to 700 Pa (for trains with $v_{tr,max} < 250$ km/h) or to 1 600 Pa and 1 100 Pa (for trains with $v_{tr,max} \geq 250$ km/h).

- (5) For the distance x_p between the entrance portal and the measuring position, the definitions of Δp_{Fr} , Δp_N , Δp_T , the minimum tunnel length and further information about the derivation of the characteristic pressure variation, see the specification referenced in Appendix J-1, index 96.
- (6) The pressure change due to altitude changes between the entry and the exit point in the tunnel shall not be taken into account in the assessment.

6.2.3.16. Cross wind (clause 4.2.6.2.4)

- (1) Conformity assessment is fully specified in clause 4.2.6.2.4

6.2.3.17. Warning Horn sound pressure levels (clause 4.2.7.2.2)

- (1) Sound pressure levels of the warning horn shall be measured and verified in accordance with the specification referenced in Appendix J-1, index 97.

6.2.3.18. Maximum power and current from the overhead contact line (clause 4.2.8.2.4)

- (1) Conformity assessment shall be carried out in accordance with the specification referenced in Appendix J-1, index 98.

6.2.3.19. Power factor (clause 4.2.8.2.6)

- (1) Conformity assessment shall be carried out according to the specification referenced in Appendix J-1, index 99.

6.2.3.20. Current collection dynamic behaviour (clause 4.2.8.2.9.6)

- (1) When a pantograph, holding an EC declaration of conformity or suitability for use as IC, is integrated in a rolling stock unit which is assessed according to the LOC&PAS TSI, dynamic tests shall be carried out in order to measure the mean contact force and standard deviation or the percentage of arcing, in accordance with the specification referenced in Appendix J-1, index 100 up to the design speed for the unit.

▼B

- (2) For a unit designed to be operated on the 1 435 mm and 1 668 mm track gauge systems, the tests, for each installed pantograph, shall be conducted in both directions of travel and shall include track sections with low contact wire height (defined as between 5,0 to 5,3 m) and track sections with high contact wire height (defined as between 5,5 to 5,75 m).

For units designed to be operated on the 1 520 mm and 1 524 mm track gauge systems, the tests shall include track sections with contact wire height between 6,0 to 6,3 m.

- (3) The tests shall be performed for a minimum of 3 speed increments up to and including the design speed of the unit. The interval between successive tests shall be no greater than 50 km/h.
- (4) During the test, the static contact force shall be adjusted for each particular power supply system within the range, as specified in clause 4.2.8.2.9.5).
- (5) The measured results shall be in accordance with the clause 4.2.8.2.9.6 for either mean contact force and standard deviation or percentage of arcing.

6.2.3.21. Arrangement of pantographs (clause 4.2.8.2.9.7)

- (1) The characteristics related to the dynamic behaviour of the current collection shall be verified as specified in clause 6.2.3.20 above.

6.2.3.22. Windscreen (clause 4.2.9.2)

- (1) The characteristics of the windscreen shall be verified as specified in the specification referenced in Appendix J-1, index 101.

6.2.3.23. Fire detection systems (clause 4.2.10.3.2)

- (1) The requirement 4.2.10.3.2 (1) shall be deemed to be satisfied by the verification that the rolling stock is equipped with a fire detection system in the following areas:
- technical compartment or cabinet, sealed or not sealed, containing electrical supply line and/or traction circuit equipment,
 - technical area with a combustion engine,
 - in sleeping cars and sleeping compartments, including their staff compartments and their adjacent gangways and their adjacent combustion heating equipment.

6.2.4. *Project phases where assessment is required*

- (1) It is detailed in Appendix H of this TSI in which phase of the project an assessment shall be done:
- Design and development phase:
 - Design review and/or design examination
 - Type test: test to verify the design, if and as defined in the Section 4.2.
 - Production phase: routine test to verify the conformity of production.

The entity in charge of the assessment of the routine tests is determined according to the assessment module chosen.

▼B

- (2) The Appendix H is structured according to the Section 4.2, which defines the requirements and their assessment applicable to the rolling stock sub-system; where relevant, a reference to a sub-clause of the clause 6.2.2.2 above is also given.

In particular, where a type test is identified in the Appendix H, the Section 4.2 shall be considered for the conditions and requirements related to this test.

- (3) Where several EC verifications (e.g. against several TSIs addressing the same sub-system) require verification based on the same production assessment (module SD or SF), it is allowed to combine several SB module assessments with one production module assessment (SD or SF). In this case, ISVs shall be issued for the design and development phases according to module SB.
- (4) If module SB is used, the validity of the EC declaration of intermediate subsystem conformity shall be indicated in accordance with the provisions for phase B of clause 7.1.3 'Rules related to the EC verification', of this TSI.

6.2.5. *Innovative solutions*

- (1) If an innovative solution (as defined article 10), is proposed for the rolling stock subsystem, the applicant shall apply the procedure described in article 10.

6.2.6. *Assessment of documentation requested for operation and maintenance*

- (1) According to Article 18 (3) of Directive 2008/57/EC, a Notified Body shall be responsible for compiling the technical file, containing the documentation requested for operation and maintenance.
- (2) The Notified Body shall verify only that the documentation requested for operation and maintenance, as defined in clause 4.2.12 of this TSI, is provided. The Notified Body is not required to verify the information contained in the documentation provided.

6.2.7. *Assessment of units intended to be used in general operation*

- (1) Where a new, upgraded or renewed unit to be used in general operation is subject to assessment against this TSI (in accordance with clause 4.1.2), some of the TSI requirements require a reference train for their assessment. This is mentioned in the relevant provisions of Section 4.2. Similarly, some of the TSI requirements at train level cannot be assessed at unit level; such cases are described for the relevant requirements in Section 4.2 of this TSI.
- (2) The area of use in terms of type of RST which, coupled with the unit to be assessed, ensures that the train is compliant with the TSI is not verified by the Notified Body.
- (3) After such a unit has received the authorisation to be placed in service, its use in a train formation (whether TSI compliant or not) shall be dealt with under the responsibility of the Railway Undertaking, according to the rules defined in clause 4.2.2.5 of the OPE TSI (train composition).

▼ B6.2.8. *Assessment of units intended to be used in predefined formation(s)*

- (1) Where a new, upgraded or renewed unit to be included in predefined formation(s) is subject to assessment (in accordance with Chapter 4.1.2), the EC certificate of verification shall identify the formation(s) for which the assessment is valid: the type of RST coupled with the unit to be assessed, number of vehicles in the formation(s), arrangement of the vehicles in the formation(s) that will ensure that the train formation will be compliant with this TSI.
- (2) TSI requirements at train level shall be assessed with use of a reference train formation when and as specified in this TSI.
- (3) After such a unit has received the authorisation to be placed in service, it may be coupled with other units to constitute the formations mentioned in the EC certificate of verification.

6.2.9. *Particular case: Assessment of units intended to be included in an existing fixed formation*6.2.9.1. **C o n t e x t**

- (1) This particular case of assessment applies in case of replacement of a part of a fixed formation, which has already been placed in service.

Two cases are described below, depending on the TSI status of the fixed formation.

The part of the fixed formation subject to the assessment is called 'unit' in the text below.

6.2.9.2. **C a s e o f a T S I c o m p l i a n t f i x e d f o r m a t i o n**

- (1) Where a new, upgraded or renewed unit to be included in an existing fixed formation is subject to assessment against this TSI, and a valid EC certificate of verification for the existing fixed formation is available, a TSI assessment only for the new part of the fixed formation is required in order to update the certificate of the existing fixed formation, which is considered as renewed (see also clause 7.1.2.2).

6.2.9.3. **C a s e o f a n o n - T S I c o m p l i a n t f i x e d f o r m a t i o n**

- (1) Where a new, upgraded or renewed unit to be included in an existing fixed formation is subject to assessment against this TSI, and a valid EC certificate of verification for the existing fixed formation is not available, the EC certificate of verification shall state that the assessment does not cover the TSI requirements applicable to the fixed formation, but only the assessed unit.

6.3. **S u b s y s t e m c o n t a i n i n g I n t e r o p e r a b i l i t y c o n s t i t u e n t s n o t h o l d i n g a n E C d e c l a r a t i o n**6.3.1. *Conditions*

- (1) During the transitional period ending on 31 May 2017, a Notified Body is permitted to issue an EC certificate of verification for a subsystem, even if some of the interoperability constituents incorporated within the subsystem are not covered by the relevant EC declarations of conformity or suitability for use according to this TSI (non-certified ICs), if the following criteria are complied with:

▼B

- (a) The conformity of the subsystem has been checked against the requirements of Section 4 and in relation to Sections 6.2 to 7 (except 'Specific cases') of this TSI by the Notified Body. Furthermore the conformity of the ICs to Sections 5 and 6.1 does not apply, and
 - (b) The interoperability constituents, which are not covered by the relevant EC declaration of conformity or suitability for use, have been used in a subsystem already approved and put in service in at least one of the Member States before the date of application of this TSI.
- (2) EC declarations of conformity or suitability for use shall not be drawn up for the interoperability constituents assessed in this manner.

6.3.2. *Documentation*

- (1) The EC certificate of verification of the subsystem shall indicate clearly which interoperability constituents have been assessed by the Notified Body as part of the subsystem verification.
- (2) The EC declaration of verification of the subsystem shall indicate clearly:
 - (a) Which interoperability constituents have been assessed as part of the subsystem;
 - (b) Confirmation that the subsystem contains the interoperability constituents identical to those verified as part of the subsystem;
 - (c) For those interoperability constituents, the reason(s) why the manufacturer did not provide an EC declaration of conformity or suitability for use before its incorporation into the subsystem, including the application of national rules notified under Article 17 of Directive 2008/57/EC.

6.3.3. *Maintenance of the subsystems certified according to clause 6.3.1*

- (1) During the transition period as well as after the transition period has ended, until the subsystem is upgraded, renewed (taking into account the MS's decision on application of TSIs), the interoperability constituents which do not hold an EC declaration of conformity or suitability for use and of the same type are permitted to be used as maintenance related replacements (spare parts) for the subsystem, under the responsibility of the ECM.
- (2) In any case the ECM must ensure that the components for maintenance related replacements are suitable for their applications, are used within their area of use, and enable interoperability to be achieved within the rail system while at the same time meeting the essential requirements. Such components must be traceable and certified in accordance with any national or international rule, or any code of practice widely acknowledged in the railway domain.

▼B

7. IMPLEMENTATION

7.1. **General rules for implementation**7.1.1. *Application to newly built rolling stock*7.1.1.1. **General**

- (1) This TSI is applicable to all units of rolling stock in its scope which are placed in service after the date of application set out in Article 12, except where clause 7.1.1.2 ‘Transition phase’ or clause 7.1.1.3 ‘Application to OTMs’ or clause 7.1.1.4 ‘Application to vehicle designed to be operated solely on 1 520 mm system’ below apply.
- (2) This TSI does not apply to units of existing rolling stock which are already placed in service on the network (or part of the network) of one Member State at the time when the TSI becomes applicable, as long as they are not upgraded or renewed (see clause 7.1.2).
- (3) Any rolling stock which is produced according to a design developed after the date of application of this TSI shall be compliant with this TSI.

7.1.1.2. **Transition phase**7.1.1.2.1 **Application of the TSI during transition phase**

- (1) A significant number of projects or contracts, which started before the date of application of this TSI, may lead to the production of rolling stock which does not fully comply with this TSI. For rolling stock concerned by those projects or contracts, and in accordance with point (f) of Article 5(3) of Directive 2008/57/EC, a transition phase is defined, during which the application of this TSI is not mandatory.
- (2) This transition phase applies to:
 - Projects at advanced stage of development, as defined in the clause 7.1.1.2.2
 - Contracts in course of performance, as defined in the clause 7.1.1.2.3
 - Rolling stock of an existing design, as defined in clause 7.1.1.2.4.
- (3) The application of this TSI to rolling stock which falls under one of the three cases above is not mandatory if one of the following conditions is met:
 - In case the rolling stock is in the scope of the HS RST TSI 2008 or of the CR LOC&PAS TSI 2011, the relevant TSI(s), including implementation rules and period of validity of the ‘type or design examination certificate’ (7 years) are applied.
 - In case the rolling stock is in the scope of neither the HS RST TSI 2008 nor the CR LOC&PAS TSI 2011: the authorisation for placing in service is delivered during a transition period ending 6 years after the date of application of this TSI.

▼B

- (4) During the transition phase, if the applicant chooses not to apply this TSI, it is reminded that the other TSIs and/or notified national rules apply according to their respective scopes and implementation rules for the authorisation to place in service in accordance with Articles 22 to 25 of Directive 2008/57/EC.

In particular, TSIs to be repealed by this TSI continue to apply, under the conditions stated in Article 11.

7.1.1.2.2 Definition of Projects at advanced stage of development

- (1) Rolling stock is developed and produced under a project at an advanced stage of development in accordance with the definition in Article 2(t) of the Directive 2008/57/EC.
- (2) The project shall be at an advanced stage of development at the date of application of this TSI.

7.1.1.2.3 Definition of Contracts in course of performance

- (1) Rolling stock is developed and produced under a contract which is signed before the date of application of this TSI.
- (2) The applicant has to bring evidence of the date of signature of the original contract applicable. The date of any addenda in the form of changes to an original contract shall not be taken into account when defining the date of signature of the contract in question.

7.1.1.2.4 Definition of Rolling Stock of an existing design

- (1) Rolling stock is produced according to a design developed before the date of application of this TSI, and which therefore has not been assessed according to this TSI.
- (2) For the purpose of this TSI, a rolling stock can be qualified as 'built according to existing design' when one of the two following conditions is met:

— The applicant can prove that the newly built rolling stock will be produced according to a documented design that has already been used to produce a rolling stock which has been authorised to be placed into service in a Member State before the date of application of this TSI.

— The manufacturer or the applicant can prove that the project was in pre-production phase, or in series production at the date of application of this TSI. In order to prove this, at least one prototype shall be in assembly phase with an existing identifiable body shell, and components already ordered from sub-suppliers shall represent 90 % of the total value of components.

The Applicant shall demonstrate to the NSA that the conditions spelled out under the respective bullet point in this clause (depending on the situation at hand) are met.

- (3) For modifications to an existing design, the following rules apply until 31 May 2017:

▼B

— In case of design modifications strictly limited to those necessary to ensure the technical compatibility of the rolling stock with fixed installations (corresponding to interfaces with infrastructure, energy, or control-command and signalling subsystems), the application of this TSI is not mandatory.

— In case of other design modifications, the present clause related to 'existing design' does not apply.

7.1.1.3. Application to mobile equipment for railway infrastructure construction and maintenance

- (1) The application of this TSI to mobile railway infrastructure construction and maintenance equipment (as defined in Sections 2.2 and 2.3) is not mandatory.
- (2) The conformity assessment process as described in the clause 6.2.1 may be used by applicants on a voluntary basis in order to establish an EC declaration of verification against this TSI; this EC declaration of verification shall be recognised as such by Member States.
- (3) In case the applicant chooses not to apply this TSI, the mobile railway infrastructure construction and maintenance equipment may be authorised in accordance with Article 24 or 25 of Directive 2008/57/EC.

7.1.1.4. Application to vehicles designed to be operated solely on the 1520 mm system

- (1) The application of this TSI to vehicles designed to be operated solely on the 1520 mm system is not mandatory during a transition period ending six years after the date of application of this TSI.
- (2) The conformity assessment process as described in the clause 6.2.1 may be used by applicants on a voluntary basis in order to establish an EC declaration of verification against this TSI; this EC declaration of verification shall be recognised as such by Member States.
- (3) In case the applicant chooses not to apply this TSI, the vehicle may be authorised in accordance with Article 24 or 25 of Directive 2008/57/EC.

7.1.1.5. Transitional measure for fire safety requirement

- (1) During a transitional period ending three years after the date of application of this TSI, it is permitted, as an alternative to material requirements specified in clause 4.2.10.2.1 of the present TSI, to apply the verification of conformity to the material fire safety requirements of the notified national rules (using the appropriate operation category) from one of the following sets of standards:
 - (2) The British standards BS6853, GM/RT2130 issue 3.
 - (3) The French standards NF F 16-101:1988 and NF F 16-102/1992.
 - (4) The German standard DIN 5510-2:2009 including toxicity measurements.

▼B

- (5) The Italian standards UNI CEI 11170-1:2005 and UNI CEI 11170-3:2005.
- (6) The Polish standards PN-K-02511:2000 and PN-K-02502:1992.
- (7) The Spanish standard DT-PCI/5A.
- (8) During this period, it is permitted to substitute individual materials by materials which are compliant with EN 45545-2:2013 (as specified in clause 4.2.10.2.1 of the present TSI).

7.1.1.6. Transitional measure for noise requirements specified in the HS RST TSI 2008

- (1) For units of maximum design speed higher than or equal to 190 km/h intended to be operated on the High Speed TEN network, requirements defined in clause 4.2.6.5 'Exterior noise' and in clause 4.2.7.6 'Interior noise' of the HS RST TSI 2008 shall apply.
- (2) This transitional measure is applicable until a revised TSI Noise covering all types of rolling stock is applicable.

7.1.1.7. Transitional measure for crosswind requirements specified in the HS RST TSI 2008

- (1) For units of maximum design speed higher than or equal to 250 km/h intended to be operated on the High Speed TEN network, it is permitted to apply requirements defined in clause 4.2.6.3 'Crosswind' of the HS RST TSI 2008, as specified in clause 4.2.6.2.4 of the present TSI.
- (2) This transitional measure is applicable until revision of the clause 4.2.6.2.4 of the present TSI.

7.1.2. *Renewal and upgrade of existing rolling stock*

7.1.2.1. Introduction

- (1) This clause provides information which relates to Article 20 of Directive 2008/57/EC.

7.1.2.2. Renewal

The Member State shall use the following principles as a basis for determining the application of this TSI in case of renewal:

- (1) A new assessment against the requirements of this TSI is only needed for the basic parameters in this TSI which may have their performance influenced by the modification(s).
- (2) For existing non-TSI compliant rolling stock, when during the renewal it is not economically feasible to fulfil the TSI requirement, the renewal could be accepted if it is evident that a basic parameter is improved in the direction of the TSI defined performance.
- (3) National migration strategies related to the implementation of other TSIs (e.g. TSIs covering fixed installations) may have an impact to what extent this TSI needs to be applied.

▼ B

- (4) For a project including elements not being TSI conform, the procedures for the assessment of conformity and EC verification to be applied should be agreed with the Member State.
- (5) For existing non-TSI compliant design of rolling stock, the replacement of a whole unit or (a) vehicle(s) within a unit (e.g. a replacement after a severe damage; see also clause 6.2.9) does not require a conformity assessment against this TSI, as long as the unit or the vehicle(s) are identical to the ones they replace. Such units must be traceable and certified in accordance with any national or international rule, or any code of practice widely acknowledged in the railway domain.
- (6) For the replacement of TSI conform units or vehicles, a conformity assessment against this TSI is required.

7.1.2.3. **Upgrade**

The Member State shall use the following principles as a basis for determining the application of this TSI in case of upgrade:

- (1) Parts and basic parameters of the subsystem that have not been affected by the upgrading works are exempt from conformity assessment against the provisions in this TSI.
- (2) A new assessment against the requirements of this TSI is only needed for the basic parameters in this TSI which have their performance influenced by the modification(s).
- (3) When during the upgrade it is not economically feasible to fulfil the TSI requirement, the upgrade could be accepted if it is evident that a basic parameter is improved in the direction of the TSI defined performance.
- (4) Guidance to the Member State for those modifications that are deemed to be upgrades is given in the application guide.
- (5) National migration strategies related to the implementation of other TSIs (e.g. TSIs covering fixed installations) may have an impact to what extent this TSI needs to be applied.
- (6) For a project including elements not being TSI conform, the procedures for the assessment of conformity and EC verification to be applied should be agreed with the Member State.

7.1.3. *Rules related to the type or design examination certificates*7.1.3.1. **Rolling stock subsystem**

- (1) This clause concerns a rolling stock type (unit type in the context of this TSI), as defined in Article 2(w) of Directive 2008/57/EC, which is subject to a EC type or design verification procedure in accordance with the Section 6.2 of this TSI.
- (2) The TSI assessment basis for a ‘type or design examination’ is defined in columns 2 and 3 (design and development phase) of Appendix H of this TSI.

Phase A

- (3) Phase A starts once a notified body, which is responsible for EC verification, is appointed by the applicant and ends when the EC type examination certificate is issued.

▼B

- (4) The TSI assessment basis for a type is defined for a phase A period, with a duration of maximum seven years. During the phase A period the assessment basis for EC verification to be used by the notified body will not change.
- (5) When a revised version of this TSI comes into force during the phase A period, it is permissible (but not mandatory) to use the revised version, either totally or for particular sections; in case of application limited to particular sections, the applicant has to justify and document that applicable requirements remain consistent, and this has to be approved by the notified body.

Phase B

- (6) The phase B period defines the period of validity of the type examination certificate once it is issued by the notified body. During this time, units may be EC certified on the basis of conformity to type.
- (7) The type examination certificate of EC verification for the subsystem is valid for a seven year phase B period after its issue date, even if a revision of this TSI comes into force. During this time, new rolling stock of the same type is permitted to be placed in service on the basis of an EC declaration of verification referring to the type certificate of verification.

Modifications to a type or design already bearing an EC certificate of verification

- (8) For modifications to a rolling stock type already bearing a type or design examination certificate of verification, the following rules apply:
 - The changes are permitted to be dealt with by only re-assessing those modifications which influence the basic parameters of the latest revision of this TSI in force at that time.
 - In order to establish the certificate of EC verification, the notified body is permitted to refer to:
 - The original type or design examination certificate for parts of the design that are unchanged, as far as it is still valid (during 7 years phase B period).
 - Additional type or design examination certificate (amending the original certificate) for modified parts of the design which influence the basic parameters of the latest revision of this TSI in force at that time.

7.1.3.2. Interoperability constituents

- (1) This clause concerns an interoperability constituent which is subject to type examination (module CB) or to suitability for use (module CV).
- (2) The type or design examination or suitability for use certificate is valid for a five year period. During this time, new constituents of the same type are permitted to be placed into service without a new type assessment. Before the end of the five-year period, the constituent shall be assessed according to the latest revision of this TSI in force at that time, for those requirements that have changed or are new in comparison to the certification basis.

▼ B**7.2. Compatibility with other subsystems**

- (1) This TSI has been developed with consideration of other subsystems being compliant to their respective TSIs. Accordingly, interfaces with the fixed installations infrastructure, energy and control-command subsystems are addressed for subsystems compliant with the TSI Infrastructure, the TSI Energy and the TSI CCS.
- (2) Following this, the implementation methods and phases concerning rolling stock depend on the progress of implementation of the TSI Infrastructure, the TSI Energy and the TSI CCS.
- (3) Furthermore, TSIs covering the fixed installations allow for a set of different technical characteristics (e.g. 'traffic code' in TSI Infrastructure, 'power supply system' in TSI Energy).
- (4) For rolling stock, the corresponding technical characteristics are recorded in the 'European register of authorised types of vehicles', according to Article 34 of Directive 2008/57/EC and Implementing Decision 2011/665/EU (see also Section 4.8 of this TSI).
- (5) For fixed installations, they are part of the main features recorded in the 'Register of infrastructure', according to Article 35 of Directive 2008/57/EC and Commission Implementing Decision 2011/633/EU ⁽¹⁾.

7.3. Specific cases**7.3.1. General**

- (1) The specific cases, as listed in the following clause, describe special provisions that are needed and authorised on particular networks of each Member State.
- (2) These specific cases are classified as:

'P' cases: 'permanent' cases.

'T' cases: 'temporary' cases, where it is planned that the target system is reached in the future.
- (3) Any specific case applicable to the rolling stock in the scope of this TSI shall be addressed in this TSI.
- (4) Certain specific cases are in interface to other TSIs. Where a clause in this TSI refers to another TSI to which a specific case is applicable, or where a specific case is applicable to the rolling stock as a consequence of a specific case declared in another TSI, these are also described in this TSI.
- (5) Moreover, some specific cases do not prevent the access to the national network to TSI compliant rolling stock. In that case, it is explicitly stated in the concerned section of the clause 7.3.2 below.

⁽¹⁾ Commission Implementing Decision 2011/633/EU of 15 September 2011 on the common specifications of the register of railway infrastructure (OJ L 256, 1.10.2011, p. 1).

▼B

7.3.2. *List of specific cases*

7.3.2.1. Mechanical interfaces (4.2.2.2)

Specific case Ireland and UK for Northern Ireland ('P')

End coupling, height above rail (clause 4.2.2.2.3, Annex A)

A.1 Buffers

The height of the centre line of the buffers shall be in the range 1 090 mm (+ 5/- 80 mm) above rail level in all loading and wear conditions.

A.2 Screw coupling

The height of the centre line of the draw hook shall be in the range 1 070 mm (+ 25/- 80 mm) above rail level in all loading and wear conditions.

Specific case United Kingdom (Great Britain) ('P')

Staff access for coupling and uncoupling (clause 4.2.2.2.5)

It is permissible for units fitted with manual coupling systems (as per clause 4.2.2.2.3 b) to alternatively comply with the national technical rules notified for this purpose.

This specific case does not prevent the access of TSI compliant rolling stock to the national network.

7.3.2.2. Gauging (4.2.3.1)

Specific case Ireland and UK for Northern Ireland ('P')

It is permissible for the reference profile of the upper and the lower part of the unit to be established in accordance with the national technical rules notified for this purpose.

Specific case the United Kingdom (Great Britain) ('P')

For technical compatibility with the existing network it is permissible for the profile of the upper and the lower part of the unit together with the pantograph gauge to alternatively be established in accordance with the national technical rules notified for this purpose.

This specific case does not prevent the access of TSI compliant rolling stock to the national network.

7.3.2.3. Rolling stock requirements for compatibility with trackside equipment (4.2.3.3.2.2)

Specific case Finland ('P')

For rolling stock intended to be used on Finnish network (1 524 mm track gauge) which depends on track side equipment for axle bearing condition monitoring, the target areas on the underside of an axle box that shall remain un-obstructed to permit observation by a trackside HABD shall use dimensions as defined in EN 15437-1:2009, and replace the values by the following:

▼B

System based on trackside equipment:

The dimensions in clauses 5.1 and 5.2 of EN 15437-1:2009 are replaced respectively by the following dimensions. There are two different target areas (I and II) including their prohibitive and measuring zones defined:

Dimensions for the target area I:

- WTA, greater than or equal to 50 mm
- LTA, greater than or equal to 200 mm
- YTA shall be 1 045 mm to 1 115 mm
- WPZ, greater than or equal to 140 mm
- LPZ, greater than or equal to 500 mm
- YPZ shall be 1 080 mm \pm 5 mm

Dimensions for the target area II:

- WTA, greater than or equal to 14 mm
- LTA, greater than or equal to 200 mm
- YTA shall be 892 mm to 896 mm
- WPZ, greater than or equal to 28 mm
- LPZ, greater than or equal to 500 mm
- YPZ shall be 894 mm \pm 2 mm

Specific case Ireland and UK for Northern Ireland ('P')

Rolling stock that depends on track side equipment for axle bearing condition monitoring, shall meet the following the target areas on the underside of an axle box (dimensions as defined in EN 15437-1:2009):

Table 18

Target area

	Y _{TA} [mm]	W _{TA} [mm]	L _{TA} [mm]	Y _{PZ} [mm]	W _{PZ} [mm]	L _{PZ} [mm]
1 600 mm	1 110 \pm 2	\geq 70	\geq 180	1 110 \pm 2	\geq 125	\geq 500

Specific case Portugal ('P')

For units intended to operate on Portuguese network (1 668 mm track gauge) and which depends on track side equipment for axle bearing condition monitoring, the target area that shall remain unobstructed to permit observation by a trackside HABD and its position related to centre line vehicle shall be the following:

- YTA = 1 000 mm (lateral position of the centre of the target area relative to the centre line of the vehicle)
- WTA \geq 65 mm (lateral width of the target area)
- LTA \geq 100 mm (longitudinal length of the target area)

▼B

- YPZ = 1 000 mm (lateral position of the centre of the prohibitive zone relative to the centre line of the vehicle)
- WPZ \geq 115 mm (lateral width of the prohibitive zone)
- LPZ \geq 500 mm (longitudinal length of the prohibitive zone)

Specific case Spain ('P')

For rolling stock intended to be used on the Spanish network (1 668 mm track gauge) and which depends on track side equipment for axle bearing condition monitoring, the zone visible to the trackside equipment on rolling stock shall be the area as defined in EN 15437-1:2009 clauses 5.1 and 5.2 considering the following values instead of the stated ones:

- YTA = 1 176 \pm 10 mm (lateral position of the centre of the target area relative to the centre line of the vehicle)
- WTA \geq 55 mm (lateral width of the target area)
- LTA \geq 100 mm (longitudinal length of the target area)
- YPZ = 1 176 \pm 10 mm (lateral position of the centre of the prohibitive zone relative to the centre line of the vehicle)
- WPZ \geq 110 mm (lateral width of the prohibitive zone)
- LPZ \geq 500 mm (longitudinal length of the prohibitive zone)

Specific case Sweden ('T')

This specific case is applicable to all units which are not fitted with on-board axle bearing condition monitoring equipment and are intended for operation on lines with non-upgraded axle bearing detectors. These lines are indicated in the infrastructure register as being non-TSI compliant in this respect.

The two zones underneath the axle box/journal set out in table below referring to the parameters of the standard EN 15437-1:2009 shall be free to facilitate vertical monitoring by trackside axle box detection system:

Table 19

Target and prohibitive zone for units intended to be operated in Sweden

	Y _{TA} [mm]	W _{TA} [mm]	L _{TA} [mm]	Y _{PZ} [mm]	W _{PZ} [mm]	L _{PZ} [mm]
System 1	862	\geq 40	whole	862	\geq 60	\geq 500
System 2	905 \pm 20	\geq 40	whole	905	\geq 100	\geq 500

The compatibility with these systems shall be set out in the technical file for the vehicle.

▼B**Specific case the United Kingdom (Great Britain) ('P')**

It is permissible to establish the compatibility with trackside equipment other than that defined in the specification referenced in Annex J-1, index 15. In such a case, the characteristics of the trackside equipment the unit is compatible with shall be described in the technical documentation (in accordance with point (4) of clause 4.2.3.3.2).

7.3.2.4. **Safety against derailment running on twisted track (4.2.3.4.1)****Specific case United Kingdom (Great Britain) ('P')**

It is permissible for all units and cases to use Method 3 set out in EN14363:2005 clause 4.1.3.4.1.

This specific case does not prevent the access of TSI compliant rolling stock to the national network.

7.3.2.5. **Running dynamic behaviour (4.2.3.4.2, 6.2.3.4, ERA/TD/2012-17/INT)****Specific case Finland ('P')**

The following modifications to the running dynamic behaviour clauses of the TSI applies to vehicle to be operated solely on Finnish 1 524 mm network:

- Test zone 4 is not applicable for running dynamic testing.
- Mean value of curve radius of all track sections for test zone 3 shall be 550 ± 50 metres for running dynamic testing.
- Track quality parameters in running dynamics testing shall be according to RATO 13 (Track inspection).
- Measuring methods are according to EN 13848:2003+A1.

Specific case Ireland and UK for Northern Ireland ('P')

For technical compatibility with the existing network it is permissible to use notified national technical rules for the purpose of assessing running dynamic behaviour.

Specific case Spain ('P')

For rolling stock intended to be used on 1 668 mm track gauge, the quasi-static guiding force Y_{qst} limit value shall be evaluated for curve radii

$$250 \text{ m} \leq R_m < 400 \text{ m}$$

The limit value shall be: $(Y_{qst})_{lim} = 66 \text{ kN}$.

The limit value shall be evaluated in accordance with ERA/TD/2012-17/INT except for the formula in clause 4.3.11.2 which shall be taken to be $(11\,550 \text{ m}/R_m - 33)$ instead.

In addition the cant deficiency threshold to be considered for applying the EN 15686:2010 shall be 190 mm.

▼B**Specific case the United Kingdom (Great Britain) ('P')**

For technical compatibility with the existing network it is permissible to use national technical rules amending EN 14363 and the ERA/TD/2012-17/INT requirements and notified for the purpose of running dynamic behaviour. This specific case does not prevent the access of TSI compliant rolling stock to the national network.

7.3.2.6. Mechanical and geometric characteristics of wheelset and wheel (4.2.3.5.2.1 and 4.2.3.5.2.2)

Specific case Estonia, Latvia, Lithuania and Poland for 1 520 mm system ('P')

The geometrical dimensions of the wheels as defined in Figure 2 shall be compliant with limit values specified in the Table 20.

Table 20

In-service limits of the geometric dimensions of wheel

Designation	Wheel diameter D (mm)	Minimum value (mm)	Maximum value (mm)
Width of the rim (B_R + Burr)	$400 \leq D \leq 1\,220$	130	146
Thickness of the flange (S_d)		21	33
Height of the flange (S_h)		28	32

Specific case Finland ('P')

The minimum wheel diameter shall be taken as 400 mm.

For rolling stock to be used in traffic between Finnish 1 524 network and a third country 1 520 network, it is allowed to use special wheelsets designed to accommodate the differences in track gauges.

Specific case Ireland ('P')

The geometrical dimensions of the wheels (as defined in Figure 2) shall be compliant with limit values specified in the Table 21:

Table 21

In-service limits of the geometric dimensions of wheel

1 600 mm	Width of the rim (B_R) (with maximum BURR of 5 mm)	$690 \leq D \leq 1\,016$	137	139
	Thickness of the flange (S_d)	$690 \leq D \leq 1\,016$	26	33
	Height of the flange (S_h)	$690 \leq D \leq 1\,016$	28	38
	Face of the flange (q_R)	$690 \leq D \leq 1\,016$	6,5	—

Specific case UK for Northern Ireland ('P')

The geometrical dimensions of the wheelsets and the wheels (as defined in Figure 1 and 2) shall be compliant with limit values specified in the Table 22:



Table 22

In-service limits of the geometric dimensions of wheelsets and wheel

1 600 mm	Front-to-front dimension (SR) SR = AR + S _d , left + S _d , right	690 ≤ D ≤ 1 016	1 573	1 593,3
	Back to back distance (AR)	690 ≤ D ≤ 1 016	1 521	1 527,3
	Width of the rim (BR) (with maximum BURR of 5 mm)	690 ≤ D ≤ 1 016	127	139
	Thickness of the flange (S _d)	690 ≤ D ≤ 1 016	24	33
	Height of the flange (S _h)	690 ≤ D ≤ 1 016	28	38
	Face of the flange (q _R)	690 ≤ D ≤ 1 016	6,5	—

Specific case Spain ('P')

The minimum value of thickness of the flange (S_d) for wheel diameter D ≥ 840 mm shall be taken as 25 mm.

For wheel diameters 330 mm ≤ D < 840 mm, the minimum value shall be taken as 27,5 mm.

Specific case United Kingdom (Great Britain) ('P')

It is permissible for the geometrical dimensions of the wheels to alternatively be established in accordance with the national technical rule notified for this purpose.

This specific case does not prevent the access of TSI compliant rolling stock to the national network.

7.3.2.7. Emergency braking (4.2.4.5.2)

Specific case United Kingdom (Great Britain) ('P')

It is permissible for units assessed in fixed or predefined formation of design maximum speed higher or equal to 250 km/h, for the stopping distance in case of 'emergency braking performance in normal mode' to deviate from the minimum values specified in point (9) of clause 4.2.4.5.2.

7.3.2.8. Aerodynamic effects (4.2.6.2)

Specific case United Kingdom (Great Britain) ('P')

Head pressure pulse (4.2.6.2.2):

Units with a maximum operating speed higher than 160 km/h and lower than 250 km/h, running in the open air at their maximum operating speed shall not cause the maximum peak-to-peak pressure of changes to exceed a value as indicated in the national technical rule notified for this purpose.

Specific case Italy ('P')

Maximum pressure variations in tunnels (4.2.6.2.3):

For unrestricted operation on the existing lines taking into account the numerous tunnels with a cross section of 54 m² which are traversed at 250 km/h, and those with a cross section of 82,5 m² and traversed at 300 km/h, units of maximum design speed higher than or equal to 190 km/h shall conform to the requirements set out in the Table 23.



Table 23

Requirements for interoperable train in a solo run in a non-inclined tube-like tunnel

	Gauge	Reference Case		Criteria for the Reference Case			Allowed maximum speed [km/h]
		V_{tr} [km/h]	A_{tr} [m ²]	Δ_{pN} [Pa]	$\Delta_{pN} + \Delta_{pFr}$ [Pa]	$\Delta_{pN} + \Delta_{pFr} + \Delta_{pT}$ [Pa]	
$V_{tr,max} < 250$ km/h	GA or smaller	200	53,6	$\leq 1\,750$	$\leq 3\,000$	$\leq 3\,700$	≤ 210
	GB	200	53,6	$\leq 1\,750$	$\leq 3\,000$	$\leq 3\,700$	≤ 210
	GC	200	53,6	$\leq 1\,750$	$\leq 3\,000$	$\leq 3\,700$	≤ 210
$V_{tr,max} < 250$ km/h	GA or smaller	200	53,6	$\leq 1\,195$	$\leq 2\,145$	$\leq 3\,105$	< 250
	GB	200	53,6	$\leq 1\,285$	$\leq 2\,310$	$\leq 3\,340$	< 250
	GC	200	53,6	$\leq 1\,350$	$\leq 2\,530$	$\leq 3\,455$	< 250
$V_{tr,max} \geq 250$ km/h	GA or smaller	250	53,6	$\leq 1\,870$	$\leq 3\,355$	$\leq 4\,865$	250
$V_{tr,max} \geq 250$ km/h	GA or smaller	250	63,0	$\leq 1\,460$	$\leq 2\,620$	$\leq 3\,800$	> 250
	GB	250	63,0	$\leq 1\,550$	$\leq 2\,780$	$\leq 4\,020$	> 250
	GC	250	63,0	$\leq 1\,600$	$\leq 3\,000$	$\leq 4\,100$	> 250

If a vehicle does not fulfil the values specified in the table above (e.g. TSI compliant vehicle), operating rules (e.g. speed restrictions) may apply.

7.3.2.9. Warning horn sound pressure levels (4.2.7.2.2)

Specific case United Kingdom (Great Britain) ('P')

Vehicle for national use only may be compliant with the horn sound pressure levels as stipulated in the national technical rules notified for this purpose.

Trains intended for international use shall be compliant with the horn sound pressure levels as specified in clause 4.2.7.2.2 of this TSI.

This specific case does not prevent the access of TSI compliant rolling stock to the national network.

7.3.2.10. Power supply — general (4.2.8.2)

Specific case United Kingdom (Great Britain) ('P')

It is permissible for electric units to be designed only for operation on lines equipped with the electrification system operating at 600/750 V DC as set out in the TSI ENE clause 7.4.2.8.1 and utilising ground level conductor rails in a three and/or four rail configuration; in that case the national technical rules notified for this purpose shall apply.

▼B

7.3.2.11. Operation within range of voltages and frequencies (4.2.8.2.2)

Specific case Estonia ('T')

Electric units designed to be operated on DC 3,0 kV lines shall be able to operate within the ranges of voltages and frequencies as set out in the TSI ENE clause 7.4.2.1.1.

Specific case France ('T')

Electric units designed to be operated on DC 1,5 kV existing lines shall be able to operate within the ranges of voltages and frequencies as set out in the TSI ENE clause 7.4.2.2.1.

The maximum current at standstill per pantograph (4.2.8.2.5) allowed on DC 1,5 kV existing lines may be lower than the limit values as set out in the TSI ENE clause 4.2.5; the current at standstill per pantograph shall be limited accordingly on electric units designed to be operated on these lines.

Specific case Latvia ('T')

Electric units designed to be operated on DC 3,0 kV lines shall be able to operate within the ranges of voltages and frequencies as set out in the TSI ENE clause 7.4.2.3.1.

Specific case United Kingdom (Great Britain) ('P')

It is permissible for electric units to be equipped with automatic regulation within abnormal operation condition regarding voltage as set out in the national technical rule notified for this purpose.

This specific case does not prevent the access of TSI compliant rolling stock to the national network.

7.3.2.12. Use of regenerative brakes (4.2.8.2.3)

Specific case Belgium ('T')

For technical compatibility with the existing system, the maximum voltage regenerated to the catenary (U_{max2} according to EN 50388:2012 clause 12.1.1) on 3 kV network shall not be higher than 3,8 kV.

Specific case Czech Republic ('T')

For technical compatibility with the existing system, the maximum voltage regenerated to the catenary (U_{max2} according to EN 50388:2012 clause 12.1.1) on 3 kV network shall not be higher than 3,55 kV.

Specific case Sweden ('T')

For technical compatibility with the existing system, the maximum voltage regenerated to the catenary (U_{max2} according to EN 50388:2012 clause 12.1.1) on 15 kV network shall not be higher than 17,5 kV.

▼B

- 7.3.2.13. Height of interaction with contact wires (RST level) (4.2.8.2.9.1.1)

Specific case United Kingdom (Great Britain) ('P')

For technical compatibility with existing lines, the installation of a pantograph on an electric unit shall allow mechanical contact of the contact wires at the extended range of wire heights in accordance with the national technical rules notified for this purpose.

- 7.3.2.14. Pantograph head geometry (4.2.8.2.9.2)

Specific case Croatia ('T')

For operation on the existing network 3 kV DC system, it is allowed to equip electric units with a pantograph having a head geometry of length 1 450 mm as depicted in EN 50367:2012, Annex B.2 figure B.1 (as alternative to requirement in clause 4.2.8.2.9.2).

Specific case Finland ('T')

For technical compatibility with the existing network, the width of the pantograph head shall not exceed 0.422 metres.

Specific case France ('T')

For operation on the existing network, in particular on lines with catenary system only compatible with narrow pantograph, and for operation in France and Switzerland, it is allowed to equip electric units with a pantograph having a head geometry of length 1 450 mm as depicted in EN 50367:2012, Annex B.2 figure B.1 (as alternative to requirement in clause 4.2.8.2.9.2).

Specific case Italy ('T')

For operation on the existing network 3 kV DC system (and additionally in Switzerland on 15 kV AC system), it is allowed to equip electric units with a pantograph having a head geometry of length 1 450 mm as depicted in EN 50367:2012, Annex B.2 figure B.1 (as alternative to requirement in clause 4.2.8.2.9.2).

Specific case Portugal ('T')

For operation on the existing network 25 kV 50 Hz system, it is allowed to equip electric units with a pantograph having a head geometry of length 1 450 mm as depicted in EN 50367:2012, Annex B.2 figure B.1 (as alternative to requirement in clause 4.2.8.2.9.2).

For operation on the existing network 1,5 kV DC system, it is allowed to equip electric units with a pantograph having a head geometry of length 2 180 mm as depicted in national rule notified for this purpose (as alternative to requirement in clause 4.2.8.2.9.2).

▼ B**Specific case Slovenia ('T')**

For operation on the existing network 3 kV DC system, it is allowed to equip electric units with a pantograph having a head geometry of length 1 450 mm as depicted in EN 50367:2012, Annex B.2 figure B.1 (as alternative to requirement in clause 4.2.8.2.9.2).

Specific case Sweden ('T')

For operation on the existing network, it is allowed to equip electric units with a pantograph having a head geometry of length 1 800 mm as depicted in EN 50367:2012, Annex B.2 figure B.5 (as alternative to requirement in clause 4.2.8.2.9.2).

Specific case United Kingdom (Great Britain) ('P')

For operation on the existing network, it is allowed to equip electric units with a pantograph having a head geometry of length 1 600 mm as depicted in EN 50367:2012, Annex B.2 figure B.6 (as alternative to requirement in clause 4.2.8.2.9.2).

7.3.2.15. Contact strip material (4.2.8.2.9.4.2)

Specific case France ('P')

The metallic content of the carbon contact strips is allowed to be increased up to 60 % by weight where used on 1 500 V DC lines.

7.3.2.16. Pantograph contact force and dynamic behaviour (4.2.8.2.9.6)

Specific case France ('T')

For technical compatibility with the existing network, electric units intended to be operated on DC 1,5 kV lines shall, in addition to the requirement of clause 4.2.8.2.9.6, be validated with consideration of a mean contact force in the following range: $70 \text{ N} < F_m < 0,00178 \cdot v^2 + 110 \text{ N}$ with a value of 140 N at standstill.

The conformity assessment procedure (simulation and/or test according to clauses 6.1.3.7 and 6.2.3.20) shall take into account the following environmental conditions:

— summer conditions: ambient temperature $\geq 35 \text{ °C}$; contact wire temperature $> 50 \text{ °C}$ for simulation.

— winter conditions: ambient temperature 0 °C ; contact wire temperature 0 °C for simulation.

Specific case Sweden ('T')

For technical compatibility with the existing network in Sweden, the static contact force of the pantograph shall fulfil the requirements in EN 50367:2012 Annex B Table B3 column SE (55 N). The compatibility with these requirements shall be set out in the technical file for the vehicle.

▼B**Specific case United Kingdom (Great Britain) ('P')**

For technical compatibility with existing lines, the verification at interoperability constituent level (clause 5.3.10 and 6.1.3.7.) shall validate capability of the pantograph to collect current for the additional range of contact wire heights between 4 700 mm and 4 900 mm.

Specific case Channel tunnel ('P')

For technical compatibility with existing lines, the verification at interoperability constituent level (clause 5.3.10 and 6.1.3.7.) shall validate capability of the pantograph to collect current for the additional range of contact wire heights between 5 920 mm and 6 020 mm.

7.3.2.17. **Driver's cab emergency exit (4.2.9.1.2.2)****Specific case United Kingdom (Great Britain) ('P')**

It is permissible for the interior exit to have a minimum access area and a minimum clearance of height and width, in accordance with the national technical rules notified for this purpose.

This specific case does not prevent the access of TSI compliant rolling stock to the national network.

7.3.2.18. **Front visibility (4.2.9.1.3.1)****Specific case United Kingdom (Great Britain) ('P')**

Instead of the requirements set out in 4.2.9.1.3.1, for rolling stock intended for operation in the UK, the following specific case shall be complied with.

The driver's cab shall be designed to allow the driver at his seated driving position a clear and unobstructed line of sight in order to distinguish fixed signals in accordance with the national technical rule, GM/RT2161 'Requirements for driving cabs of railway vehicles'.

This specific case does not prevent the access of TSI compliant rolling stock to the national network.

7.3.2.19. **Driver's desk — Ergonomics (4.2.9.1.6)****Specific case United Kingdom (Great Britain) ('P')**

In case the requirements in clause 4.2.9.1.6, last paragraph, related to the direction of movement of the lever for traction and/or braking is incompatible with the safety management system of the railway undertaking operating in Great Britain, it is allowed to inverse the direction of movement for braking and traction respectively.

7.3.2.20. **Fire safety and evacuation (4.2.10)****Specific case Italy ('T')**

Additional specifications for units intended to be operated in the existing Italian tunnels are detailed below.

▼B***Fire detection systems (clauses 4.2.10.3.2 and 6.2.3.23)***

In addition to the areas specified in clause 6.2.3.23, fire detection systems shall be installed in all passenger and train staff areas.

Fire containment and control systems for passenger rolling stock (clause 4.2.10.3.4)

In addition to requirements of the clause 4.2.10.3.4, units of category A and B passenger rolling stock shall be equipped with active Fire Containment and Control Systems.

Fire Containment and Control Systems shall be assessed according to the notified National Rules about fire automatic extinguishing systems.

In addition to the requirements specified in clause 4.2.10.3.4, the units of category A and B passenger rolling stock shall be equipped with automatic fire extinguishing systems in all technical areas.

Freight locomotives and freight self-propelling units: fire spreading protection measures (clause 4.2.10.3.5) and running capability (clause 4.2.10.4.4)

In addition to the requirements specified in clause 4.2.10.3.5, freight locomotives and freight self-propelling units shall be equipped with fire automatic extinguishing systems in all technical areas.

In addition to the requirements specified in clause 4.2.10.4.4, freight locomotives and freight self-propelling units shall have a running capability equivalent to that of category B passenger rolling stock.

7.3.2.21. Running capability (4.2.10.4.4) and fire containment and control system (4.2.10.3.4)

Specific case Channel Tunnel ('T')

Passenger rolling stock intended to be operated in the Channel Tunnel shall be of category B, considering the length of the tunnel.

Due to the lack of firefighting points with safe area (see TSI SRT, clause 4.2.1.7) amendments to the following clauses apply:

— clause 4.2.10.4.4 (3):

The running capability of a Passenger rolling stock intended to be operated in the Channel Tunnel shall be demonstrated by application of the specification referenced in Annex J-1, index 63, in which the system functions impacted by a 'type 2' fire shall be braking and traction; these functions shall be assessed in the following conditions

— for a duration of 30 minutes at a minimum speed of 100 km/h, or

— for a duration of 15 minutes at a minimum speed of 80 km/h (according to clause 4.2.10.4.4) under the condition specified in the national rule notified by the Channel tunnel safety authority for this purpose.

▼B

— clause 4.2.10.3.4 (3) & (4):

Where the running capability is specified for a duration of 30 minutes according to the point above, the fire barrier between the driver's cab and the compartment to the rear of it (assuming the fire starts in the rear compartment) shall satisfy requirements for integrity for a minimum of 30 minutes (instead of 15 minutes).

Where the running capability is specified for a duration of 30 minutes according to the point above, and for passenger vehicles that do not allow the exit of passengers at both ends (no through route), measures to control the spread of heat and fire effluents (full cross section partitions or other FCCS, fire barriers between combustion engine/electrical supply/traction equipment and passenger/staff areas) shall be designed for a minimum of 30 minutes fire protection (instead of 15 minutes).

7.3.2.22. Interface for toilet discharge (4.2.11.3)

Specific case Finland ('P')

Alternatively to, or in addition to what is specified in clause 4.2.11.3, it is allowed to install connections for toilet discharge and for rinsing of the sanitary discharge tanks, compatible with the track side installations on the Finnish network in accordance with figure AI1.

Figure AI 1. Emptying connections for toilet tank

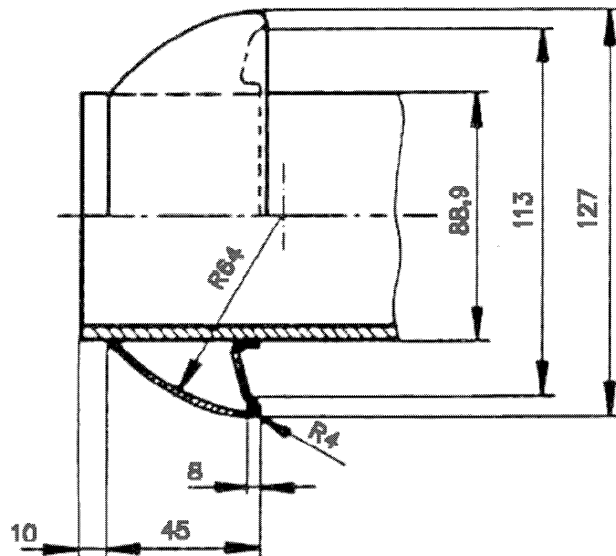

Quick connector SFS 4428, connector part A, size DN80

Material: acid-proof stainless steel

Sealing on the counter-connector's side.

Specific definition in the standard SFS 4428

▼B

7.3.2.23. Interface for water refilling (4.2.11.5)

Specific case Finland ('P')

Alternatively to, or in addition to what is specified in clause 4.2.11.5, it is allowed to install water filling connections compatible with the track side installations on the Finnish network in accordance with Figure A III.

Figure A III The water filling adapters

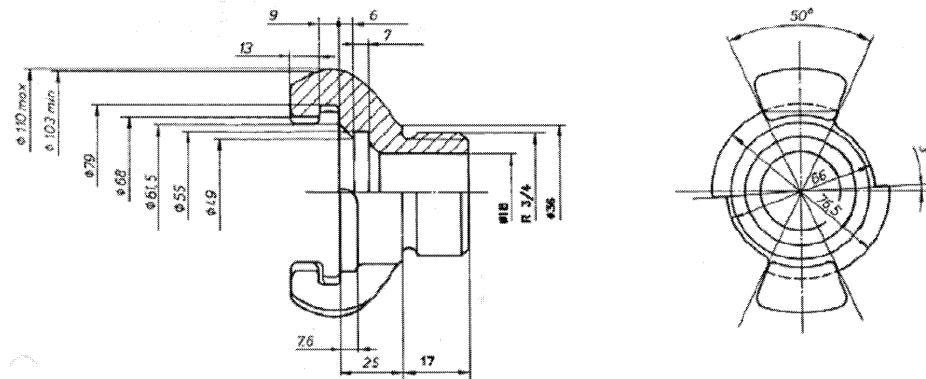

Type: Connector C for fire fighting NCU1

Material: brass or aluminium

Specific definition in the standard SFS 3802 (sealing defined by each connector manufacturer).

Specific case Ireland and UK for Northern Ireland ('P')

Alternatively to, or in addition to what is specified in clause 4.2.11.5 of this TSI, it is allowed to install a nozzle type water refilling interface. This nozzle type refilling interface must fulfil the requirements of the national technical rules notified for the purpose.

7.3.2.24. Special requirements for stabling of trains (4.2.11.6)

Specific case Ireland and UK for Northern Ireland ('P')

Shore supply of electrical power to stabled trains must fulfil the requirements of the national technical rules notified for the purpose

Specific case the United Kingdom (Great Britain) ('P')

It is permissible for the local external auxiliary power supply 400 V to be provided in accordance with the national technical rules notified for this purpose.

7.3.2.25. Refuelling equipment (4.2.11.7)

Specific case Finland ('P')

In order to be able to be refuelled on the Finnish network, the fuel tank of units with a diesel filling interface has to be equipped with the over flow controller according to standards SFS 5684 and SFS 5685.

▼B**Specific case Ireland and UK for Northern Ireland ('P')**

The refuelling equipment interface must fulfil the requirements of the national technical rules notified for the purpose.

- 7.3.2.26. Rolling stock originated from third country (general)

Specific case Finland

('P') The application of national technical rules instead of the requirements in this TSI is allowed for third countries' rolling stock to be used on the Finnish 1 524 network in traffic between Finland and 3rd countries 1 520 network

- 7.4. **Specific environmental conditions**

Specific conditions Austria

Unrestricted access in Austria under winter conditions is granted if the following conditions are met:

- The additional capability of the obstacle deflector to remove snow as specified for snow, ice and hail severe conditions in clause 4.2.6.1.2 shall be provided.
- Locomotives and power head units shall be provided with sanding devices.

Specific conditions Estonia

For unrestricted access of rolling stock on the Estonia network under winter conditions, it shall be demonstrated that the rolling stock meets the following requirements:

- Temperature zone T2 as specified in clause 4.2.6.1.1 shall be selected.
- Snow, ice and hail severe conditions as specified in clause 4.2.6.1.2, excluding the scenario 'Snowdrift' shall be selected.

Specific conditions Finland

For unrestricted access of rolling stock on the Finnish network under winter conditions, it shall be demonstrated that the rolling stock meets the following requirements:

- Temperature zone T2 as specified in clause 4.2.6.1.1 shall be selected
- Snow, ice and hail severe conditions as specified in clause 4.2.6.1.2, excluding the scenario 'Snowdrift' shall be selected
- Regarding the braking system, unrestricted access in Finland under winter conditions is granted if the following conditions are met:
 - at least half of the bogies are equipped with a magnetic track brake for trainset or passenger coach of nominal speed exceeding 140 km/h.
 - all bogies are equipped with a magnetic track brake for trainset or passenger coach of nominal speed exceeding 180 km/h.

▼ B*Specific conditions France*

Unrestricted access in France under winter conditions is granted if the following condition is met:

- locomotives and power head units shall be provided with sanding devices.

Specific conditions Greece

For unrestricted access to the Greek network under summer conditions, temperature zone T3 as specified in clause 4.2.6.1.1 shall be selected.

Specific conditions Germany

Unrestricted access in Germany under winter conditions, is granted if the following condition is met:

- locomotives and power head units shall be provided with sanding devices.

Specific conditions Portugal

For unrestricted access to the Portuguese network under summer conditions, temperature zone T3 as specified in clause 4.2.6.1.1 shall be selected.

Specific conditions Spain

For unrestricted access to the Spanish network under summer conditions, temperature zone T3 as specified in clause 4.2.6.1.1 shall be selected.

Specific conditions Sweden

For unrestricted access of rolling stock on the Swedish network under winter conditions, it shall be demonstrated that the rolling stock meets the following requirements:

- Temperature zone T2 as specified in clause 4.2.6.1.1 shall be selected
- Snow, ice and hail severe conditions as specified in clause 4.2.6.1.2 shall be selected

7.5. **Aspects that have to be considered in the revision process or in other activities of the Agency**

Further to the analysis performed during the drafting process of this TSI, particular aspects have been identified as of interest for the future development of the EU railway system.

These aspects are of 3 different groups:

- (1) Those already subject of a basic parameter in this TSI, with a possible evolution of the corresponding specification when the TSI will be revised.
- (2) Those not considered in the current state of the art as basic parameter, but which are subject to research projects.
- (3) Those relevant in the framework of ongoing studies related to the EU railway system, which are not in the scope of TSIs.

These aspects are identified below, classified according to the breakdown of the clause 4.2 of the TSI.

▼B

7.5.1. *Aspects related to a basic parameter in this TSI*

7.5.1.1. Axle load parameter (clause 4.2.3.2.1)

This basic parameter covers the interface between infrastructure and rolling stock regarding the vertical load.

According to the TSI INF, the lines are classified as specified in the standard EN 15528:2008. This standard specifies also a categorization of railway vehicles, for freight wagons and particular types of locomotives and passenger vehicles; it will be revised to cover all types of rolling stock, and to cover HS lines.

When this revision will be available, it may be of interest to include in the EC certificate delivered by the Notified Body the 'design' classification of the unit under assessment:

- Classification corresponding to the design mass under normal payload.
- Classification corresponding to the design mass under exceptional payload.

This aspect will have to be considered when revising this TSI, which already requires in its present version to record all data necessary to determine these classifications.

It has to be noted that the requirement to the railway undertaking to define and control the operational load, as specified in the clause 4.2.2.5 of the TSI OPE will remain unchanged.

7.5.1.2. Aerodynamic effects — Cross wind (clause 4.2.6.2.4)

Requirements on 'cross wind' have been set up for units of maximum design speed equal to or higher than 250 km/h with 2 options:

- in consistency with the TSI HS RST 2008, or
- in consistency with the TSI CR LOC&PAS 2011.

This will need to be reviewed when the merging of the 2 sets of characteristics wind curves specified in the TSI HS RST 2008 will be finalised.

7.5.2. *Aspects not related to a basic parameter in this TSI but subject to research projects*

7.5.2.1. Additional requirements for security reasons

The interior of vehicles interfacing with passengers and train crew should provide protection of the occupants in the event of a collision by providing means of:

- minimising the risk of injury due to secondary impact with such furniture and interior fixtures and fittings
- minimising those injuries that may preclude subsequent escape

▼ B

Some EU research projects have been launched in 2006 to study the consequence of railway accidents (collision, derailment...) on passengers, to evaluate in particular the risk and level of injuries; the objective is to define requirements and corresponding conformity assessment procedures related to the railway vehicles interior layouts and components.

This TSI already provides a number of specifications in order to cover such risks, for example, Sections 4.2.2.5, 4.2.2.7, 4.2.2.9 and 4.2.5.

More recently, studies have been launched at Member State level and at European level (by the Commission joint research centre) regarding the protection of the passengers in the event of terrorist attack.

The Agency will follow these studies, and will consider their outcome to define if additional basic parameters or requirements covering the risk of injuries of passengers in case of accident or terrorist attack shall be recommended to the Commission. Where appropriate this TSI shall be amended.

Pending the revision of this TSI Member States may use national rules to cover such risks. In any case this shall not prevent the access of TSI compliant rolling stock operating across Member State borders onto their national network.

7.5.3. *Aspects relevant for the EU railway system but out of the scope of TSI's*

7.5.3.1. **Track interaction (clause 4.2.3) — Flange or track lubrication**

During the drafting process of this TSI, it has been concluded that the 'flange or track lubrication' is not a basic parameter (no link to essential requirements as defined in Directive 2008/57/EC).

Nevertheless, it appears that the actors of the railway sector (IMs, RUs, NSAs) need a support from the Agency in order to move from the current practices to an approach that will ensure transparency and will avoid any unjustified barrier to the circulation of rolling stock on the EU network.

To that end, the Agency has suggested to launch a study together with the railway sector, with the objective to clarify the key technical and economic aspects of this function, considering the current situation:

- Lubrication is required by some infrastructure managers, but also forbidden by others.
- Lubrication may be provided by means of fixed installation designed by the infrastructure manager or by means of on board device to be provided by the railway undertaking.
- Different ways of lubrication have been investigated by the railway sector.
- Environmental aspects have to be considered when releasing grease along the track.

▼B

In any case, it is planned to include in the 'Infrastructure register' information on 'flange or rail lubrication', and the 'European register of authorised types of vehicles' will mention if the rolling stock is fitted with on-board flange lubrication. The study mentioned above will clarify operating rules.

In the meantime, Member States may continue to use national rules in order to cover this issue of the vehicle-track interface. Those rules shall be made available either through notification to the Commission in accordance with article 17 of Directive 2008/57/EC or through the Infrastructure Register referred to in article 35 of the same Directive.

▼B

APPENDICES

- Appendix A: Buffer and draw gear
- Appendix B: 1 520 mm system gauge 'T'.
- Appendix C: Special provisions for mobile railway infrastructure construction and maintenance equipment
- Appendix D: Energy meter
- Appendix E: Anthropometric measurements of the driver
- Appendix F: Front visibility
- Appendix G: Servicing
- Appendix H: Assessment of the rolling stock subsystem
- Appendix I: List of aspects for which the technical specification is not available (open points)
- Appendix J: List technical specifications referred to in this TSI
 - Appendix J-1: List of standards or normative documents.
 - Appendix J-2: List of technical documents available on ERA website.

▼B*Appendix A***Buffers and screw coupling system****A.1. Buffers**

When buffers are fitted to a unit end, they shall be paired (i.e. symmetrical and opposite handed) and have the same characteristics.

The height of the centre line of the buffers shall be between 980 mm and 1 065 mm above rail level in all loading and wear conditions.

For car carriers under maximum load and locomotives, the minimum height of 940 mm is allowed.

The standard distance between buffer centrelines shall be nominally:

— on 1 435 mm track gauge: 1 750 mm \pm 10 mm symmetrically about the centreline of the vehicle.

It is permitted for dual gauge units intended for running between standard gauge network 1 435 mm and broad gauge networks to have a different value of the distance between buffer centrelines (e.g. 1 850 mm), provided that full compatibility with buffers for standard 1 435 mm gauge is ensured.

— on 1 524 mm track gauge: 1 830 mm (+/- 10 mm)

— on 1 600 mm track gauge: 1 905 mm (+/- 3 mm).

— on 1 668 mm track gauge: 1 850 mm \pm 10 mm symmetrically about the centreline of the vehicle, taking into account the particular provisions defined in clause 6.2.3.1 of the specification referenced in Annex J-1, index 67

Buffers shall be sized so that in horizontal curves and reverse curves, it is not possible for vehicles to lock buffers. The minimum horizontal overlap between buffer heads in contact shall be 25 mm.

Assessment test:

The determination of the buffer size has to be made with two vehicles going through a S-curve of 190 m radius without intermediate straight section and in a S-curve of 150 m radius with intermediate straight section of at least 6 m.

A.2. Screw coupling

The standard screw coupling system between vehicles shall be non-continuous and comprise of a screw coupling permanently attached to the hook, a draw hook and a draw bar with an elastic system.

The height of the centre line of the draw hook shall be between 950 mm and 1 045 mm above rail level in all loading and wear conditions.

For car carriers under maximum load and locomotives, the minimum height of 920 mm is allowed. The maximum height difference between new wheels with design mass in working order and fully worn wheels with design mass under normal design payload shall not exceed 85 mm for the same vehicle. Assessment shall be done by calculation.

Each vehicle end shall have a facility for supporting a shackle when it is not in use. No part of the coupler assembly shall reach below 140 mm above rail level in the lowest admissible position of the buffers.

▼B

- Screw coupling, draw hook and draw gear dimensions and characteristics shall be according to the specification referenced in Annex J-1, index 68
- The maximum weight of the screw coupling shall not exceed 36 kg, not including the weight of the coupling hook pin (item no.1 on fig. 4 and 5 of the specification referenced in Annex J-1, index 68).

A.3. Interaction of draw- and buffing-gear

- Static characteristics of draw gears and buffers shall be coordinated in order to ensure that a train is able to negotiate curves of the minimum radius defined in clause 4.2.3.6 of this TSI safely in normal coupling conditions (e.g. without locking buffers, etc.)
- Screw coupling and buffing gear layout:
 - The distance between the front edge of a draw-hook opening and the front side of the fully extended buffers shall be $355 \text{ mm} + 45/-20 \text{ mm}$ in the new condition as shown in fig. A1.

*Figure A1***Draw gear and buffers**

Structures and mechanical parts

Buffers

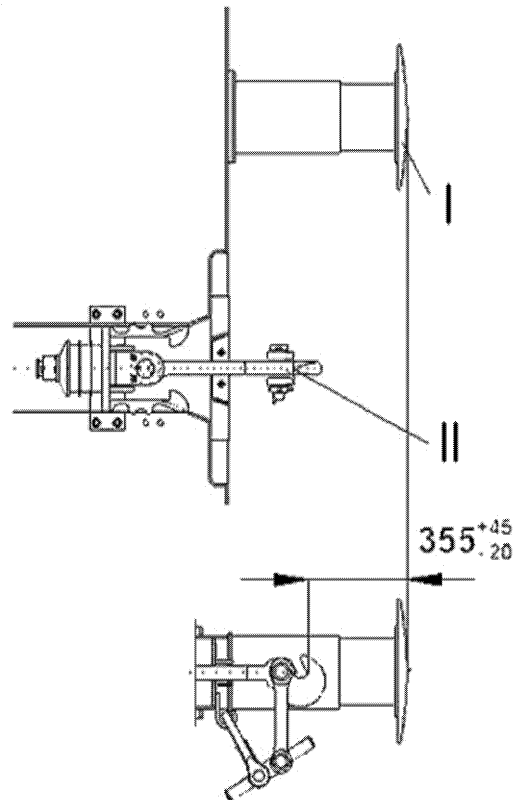

- I Fully extended buffer
- II Draw-hook opening

▼ B

Appendix B

1 520 mm system gauge 'T'

Reference profile for the track gauge 1 520 'T' of the upper parts (for rolling stock):

Running surface

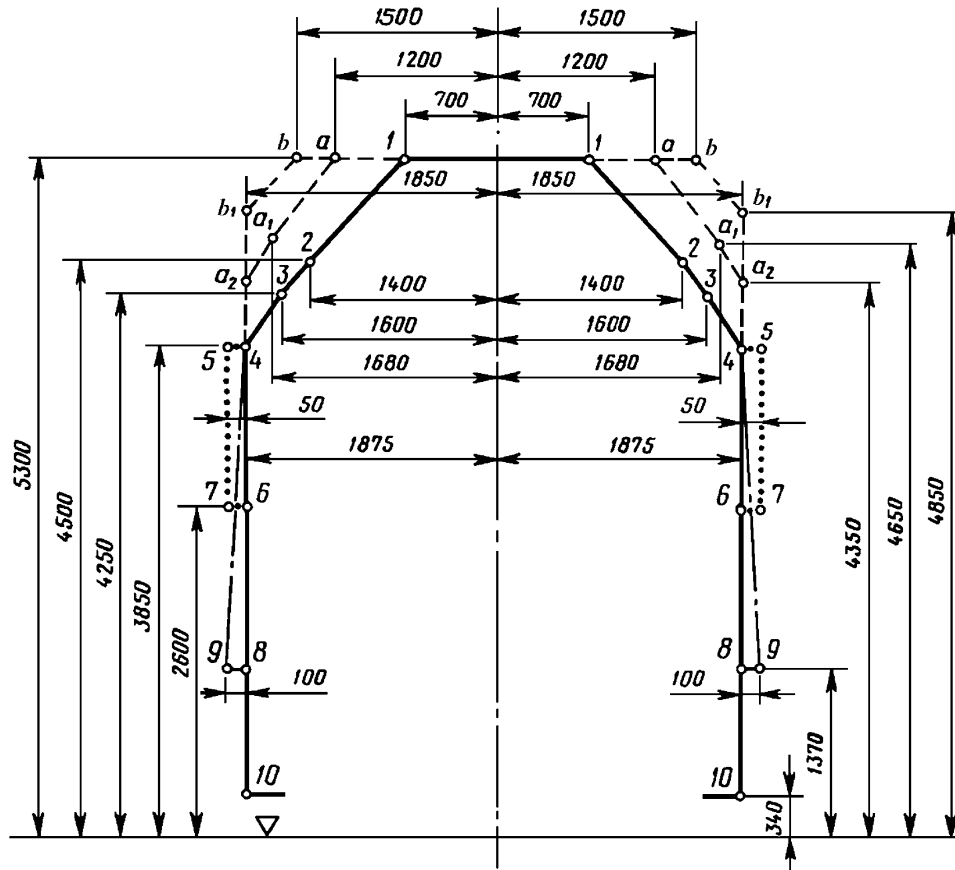

(Dimensions in mm)

● ● ● ● ● ● ● zone for signals installed of the vehicle

Reference profile for the lower parts:

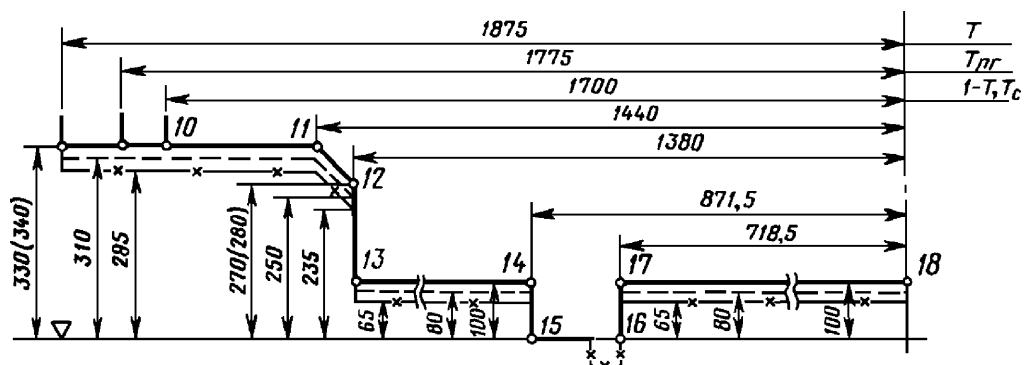

▼ **B**

Note: For the rolling stock which is intend to be used on track of 1 520 mm, with the exception to pass over of marshalling humps equipped with rail brakes.

Reference profile for the lower parts:

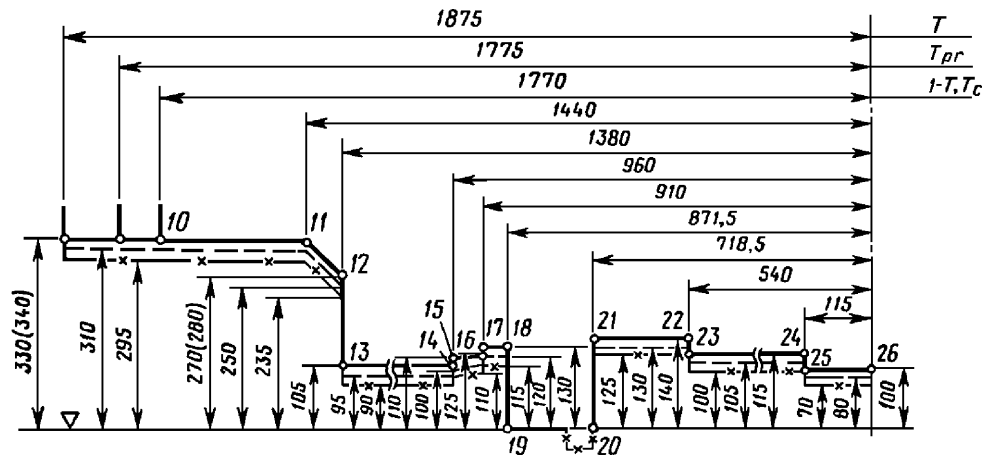

Note: For the rolling stock which is intend to be used on track of 1 520 mm, able to pass over marshalling humps and rail brakes.



Appendix C

Special provisions for on track machines (OTM)

C.1 Strength of vehicle structure

The requirements of the clause 4.2.2.4 of this TSI are complemented as follow:

The machine frame shall be able to withstand either the static loads of the specification referenced in Annex J-1, index 7 or the static loads according to the specification referenced in Annex J-1, index 102 without exceeding the permissible values given there in.

The corresponding structural category of the specification referenced in Annex J-1, index 102 is as follows:

- for machines not permitted to be loose shunted or hump shunted: F-II;
- for all other machines: F-I.

The acceleration in x-direction according to the specification referenced in Annex J-1, index 7, Table 13 or to the specification referenced in Annex J-1, index 102, Table 10 shall be ± 3 g.

C.2 Lifting and jacking

The machine body shall incorporate lifting points by which the whole machine is capable of being safely lifted or jacked. The location of the lifting and jacking points shall be defined.

To facilitate the work during repair or inspection or when on-tracking the machines, the machines shall be provided on both long sides with at least two lifting points, at which the machines can be lifted in empty or loaded condition.

To allow positioning of jacking devices, clearances shall be provided under the lifting points which shall not be blocked by the presence of non-removable parts. The load cases shall be consistent with the ones chosen in Appendix C.1 of this TSI and shall apply for lifting and jacking under workshop and servicing operations.

C.3 Running dynamic behaviour

The running characteristics are permitted to be determined by running tests or by reference to a similar type approved machine as detailed in clause 4.2.3.4.2 of this TSI or by simulation.

The following additional deviations from the specification referenced in Annex J-1, index 16 apply:

- The test shall always be taken as the simplified method for this type of machines
- when running tests according to the specification referenced in Annex J-1, index 16 are done with wheel profile in new condition, these are valid for a maximum distance of 50 000 km. After 50 000 km it is necessary to:
 - either re-profile the wheels;

▼B

- or calculate the equivalent conicity of the worn profile and check that it does not differ more than 50 % from the value of the test of the specification referenced in Annex J-1, index 16 (with a maximum difference of 0,05);
- or make a new test according to the specification referenced in Annex J-1, index 16 with worn wheel profile;
- in general, stationary tests to determine the parameters of characteristic running gear in accordance with to the specification referenced in Annex J-1, index 16, clause 5.4.3.2 are not necessary;
- if the required test speed cannot be obtained by the machine itself, the machine shall be hauled for the tests.
- when test zone 3 (as described in Table 9 of to the specification referenced in Annex J-1, index 16) is used it is sufficient to have a minimum of 25 conformant track sections.

Running behaviour can be proven by simulation of the tests described in to the specification referenced in Annex J-1, index 16 (with the exceptions as specified above) when there is a validated model of representative track and operating conditions of the machine.

A model of a machine for simulation of running characteristics shall be validated by comparing the model results against the results of running tests when the same input of track characteristic is used.

A validated model is a simulation model that has been verified by an actual running test that excites the suspension sufficiently and where there is a close correlation between the results of the running test and the predictions from the simulation model over the same test track.

▼ B*Appendix D***On-board energy measurement system****1. Requirements for on-board energy measuring system (EMS) — System requirements**

The functions of the system shall be:

- Energy measurement function (EMF), measuring the voltage and current, calculating the energy and producing energy data.
- Data handling system (DHS), producing compiled energy billing data sets for energy billing purposes, by merging data from the EMF with time data and geographical position, and storing it to be sent to on-ground data collection system (DCS) by a communication system.
- On-board location function, giving geographical position of the traction unit.

Where data coming from the on-board location function is not necessary for billing purposes in the Member State concerned, it is permissible to not install the components dedicated to that function. In any case, any such EMS system shall be produced with consideration of the possible future inclusion of a location function.

The functions above may be performed by individual devices or may be combined in one or more integrated assemblies.

The abovementioned functions and their data flow diagram are illustrated in the figure below.

Figure D-1

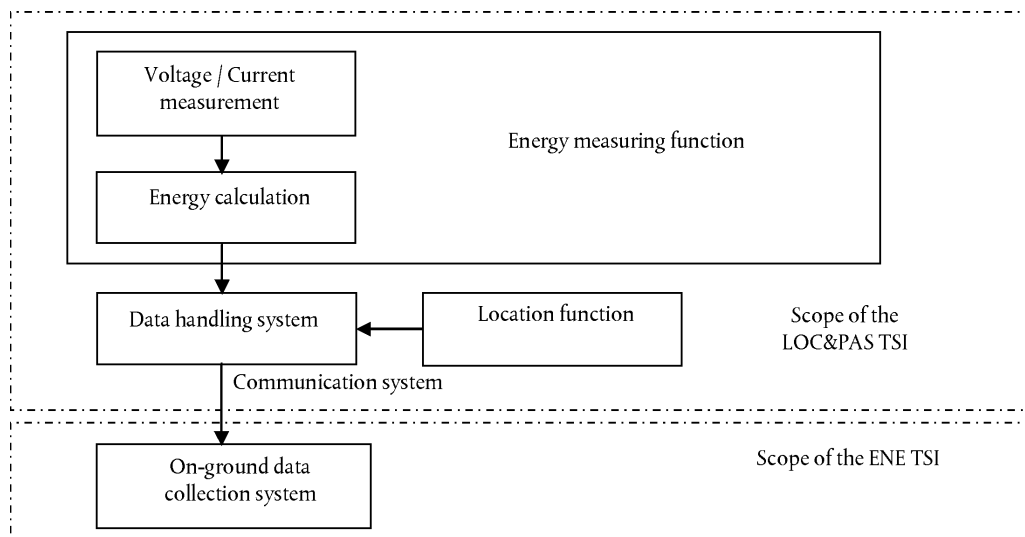

The EMS shall measure energy supplied by the power supply systems for which the traction unit is designed and shall fulfil the following requirements:

- all active and reactive energy taken from and returned to the OCL is measured;

▼B

- the EMS rated current and voltage shall be matched to the traction unit rated current and voltage;
- it shall continue to function correctly when changing between traction energy supply systems;
- the EMS shall be protected from non-authorized access;
- loss of the power supply to the EMS shall not affect data stored in the EMS.

It is permissible to access the data in the EMS for other purposes (e.g. feedback to the driver in connection with the efficient operation of the train) provided that it can be demonstrated that the integrity of EMS functions and data are not compromised by this arrangement.

2. **Energy measuring function (EMF)**

2.1. *Metrological requirements*

EMF is subject to metrological control, which shall be executed in accordance with the following:

- (1) Accuracy of EMF for active energy measurement shall comply with clauses 4.2.4.1 to 4.2.4.4 of the specification referenced in Annex J-1, index 103
- (2) Each device containing one or more functions of EMF shall indicate:
 - (a) metrological control, and
 - (b) its accuracy class, according to the class designations specified in the specification referenced in Annex J-1, index 103.

The accuracy class shall be verified by testing.

2.2. *Other requirements*

The measured energy values produced by EMF shall have a time reference period of 5 minutes defined by the UTC clock time at the end of each time reference period; originating from the time stamp 00:00:00.

It is permitted to use a shorter measuring period if the data can be aggregated on-board into 5 minutes time reference period.

3. **Data handling system (DHS)**

The DHS shall compile the data without corrupting them.

The DHS shall use, as a time reference, the same source of clock as in the EMF.

The DHS shall incorporate data storage with a memory capacity sufficient to store the compiled data of at least 60 days' continuous work.

The DHS shall have a capability to be interrogated locally by authorised personnel on board the train using appropriate equipment (e.g. laptop computer) in order to provide an opportunity for audit, and an alternative method of recovering data.

The DHS shall produce CEBD (compiled energy billing data sets) by merging the following data for each time reference period:

▼ B

- unique EMS identification number, consisting of the European vehicle number (EVN) followed by one additional digit uniquely identifying each EMS on-board the traction unit, and no dividers included;
- end time of each period, defined as year, month, day, hour, minute and second;
- the location data at the end of each period;
- consumed/regenerated active and reactive (if appropriate) energy in each period, in units of Wh (active energy) and varh (reactive energy) or their decimal-multiples.

4. Location function

The location function shall provide location data to the DHS which originates from an external source.

The data from the location function shall be synchronised in accordance with UTC clock time and time reference period with the on-board EMF.

The location function shall provide the position expressed in latitude and longitude using decimal degrees with five decimal places. Positive values shall be used for North and East; negative values shall be used for South and West.

In open air the location function shall have an accuracy of 250 m or less.

5. On-board to ground communication

The specification related to interface protocols and transferred data format are an open point.

6. Particular assessment procedures**6.1. Energy measurement system**

Where assessment methods set out in the standard series referenced in Annex J-1, index 103, 104 and 105 are referenced below, only those aspects necessary for the assessment of the requirements above in this Appendix D shall be undertaken in relation to the EMS which is a part of the EC verification activity for the rolling stock subsystem

6.1.1. EMF

The accuracy of the each device containing one or more functions of EMF shall be assessed by testing each function, under reference conditions, using the relevant method as described in clause 5.4.3.4.1, 5.4.3.4.2 and 5.4.4.3.1 of the specification referenced in Annex J-1, index 103. The input quantity and power factor range when testing shall correspond to the values set out in Table 3 of the specification referenced in Annex J-1, index 103.

The accuracy of the complete EMF shall be assessed by calculation, using the method described in clause 4.2.4.2 of the specification referenced in Annex J-1, index 103.

The effects of temperature on accuracy of the each device containing one or more functions of EMF shall be assessed by testing each function, under reference conditions (except for temperature), using the relevant method as described in clause 5.4.3.4.3.1, and 5.4.4.3.2.1 of the specification referenced in Annex J-1, index 103.

▼B

The mean temperature coefficient of each device containing one or more functions of EMF shall be assessed by testing each function, under reference conditions (except for temperature), using the relevant method as described in clause 5.4.3.4.3.2 and 5.4.4.3.2.2 of the specification referenced in Annex J-1, index 103.

6.1.2 DHS

The compiling and handling of data within the DHS shall be assessed by testing using the method as described in clause 5.4.8.3.1, 5.4.8.5.1, 5.4.8.5.2 and 5.4.8.6 of the specification referenced in Annex J-1, index 104.

6.1.3 EMS

The correct functioning of the EMS shall be assessed by testing using the method as described in clause 5.3.2.2, 5.3.2.3, 5.3.2.4 and 5.5.3.2 of the specification referenced in Annex J-1, index 105.

▼ B*Appendix E***Anthropometric measurements of the driver**

The following data represents the ‘state of the art’ and shall be used.

Note: they will be subject of an EN standard currently under drafting process.

— Principal anthropometric measurements of the shortest and tallest driving staff:

The dimensions given in Appendix E of the UIC 651 (4th edition, July 2002) shall be taken into consideration.

— Additional anthropometric dimensions of the shortest and tallest driving staff:

The dimensions given in Appendix G of the UIC 651 (4th edition, July 2002) shall be taken into consideration.

▼ B*Appendix F***Front visibility**

The following data represents the 'state of the art' and shall be used.

Note: they will be subject of an EN standard currently under drafting process.

F.1. General

The design of the cab shall support the drivers' view of all external information that form part of the driving task as well as protecting the driver from external sources of visual interference. This shall include the following:

- Flicker at the lower edge of the windscreen, which can cause fatigue, shall be reduced
- Protection shall be provided from the sun and glare of headlights from oncoming trains, without reducing the drivers' view of external signs, signals and other visual information
- Location of cab equipment shall not block or distort the drivers view of external information
- The dimension, location, shape and finishes (including maintenance) of the windows shall not inhibit the drivers external view and shall support the driving task
- The location, type and quality of windscreen cleaning and clearance devices shall ensure that the driver is able to maintain a clear external view in most weather and operating conditions, and shall not inhibit the drivers external view.
- The driver's cab shall be designed in such a way that the driver is facing forwards when driving.
- The driver's cab shall be designed to allow the driver at his seated driving position a clear and unobstructed line of sight in order to distinguish fixed signals set to both the left and right of the track, as defined in Appendix D of the UIC 651(4th edition, July 2002).

Note: the position of the seat in the Appendix D mentioned here above has to be considered as an example; the TSI does not impose the position of the seat (left, central or right) in the cab; the TSI does not impose the standing driving position on all types of units.

The rules expressed in the Appendix above govern the conditions of visibility for each running direction along straight track and in curves with a radius of 300 m and more. They apply to the position(s) of the driver.

Notes:

- in case of cab fitted with 2 driver's seats (option with 2 driving positions), they apply to the 2 seated positions.
- for locomotives with central cab and for OTMs, the clause 4.2.9.1.3.1 of the TSI specify particular conditions.

▼B**F.2. Reference position of vehicle in relation to track:**

The clause 3.2.1 of the UIC 651(4th edition, July 2002) shall apply.

The supplies and payload shall be considered as defined in the specification referenced in Annex J-1, index 13 and clause 4.2.2.10 of this TSI.

F.3. Reference position for the eyes of crew members

The clause 3.2.2 of the UIC 651(4th edition, July 2002) shall apply.

The distance from the driver's eyes in seating posture to the windscreen shall be higher than or equal to 500 mm.

F.4. Conditions of visibility

The clause 3.3 of the UIC 651(4th edition, July 2002) shall apply.

Note: the clause 3.3.1 of the UIC 651 refers for the standing position to its clause 2.7.2, specifying a minimum distance of 1.8 meters between floor and top edge of the front window.

▼B

Appendix G

Servicing

Connections for the toilet discharge system on rolling stock:

Figure G1

Evacuation nozzle (Inner part)

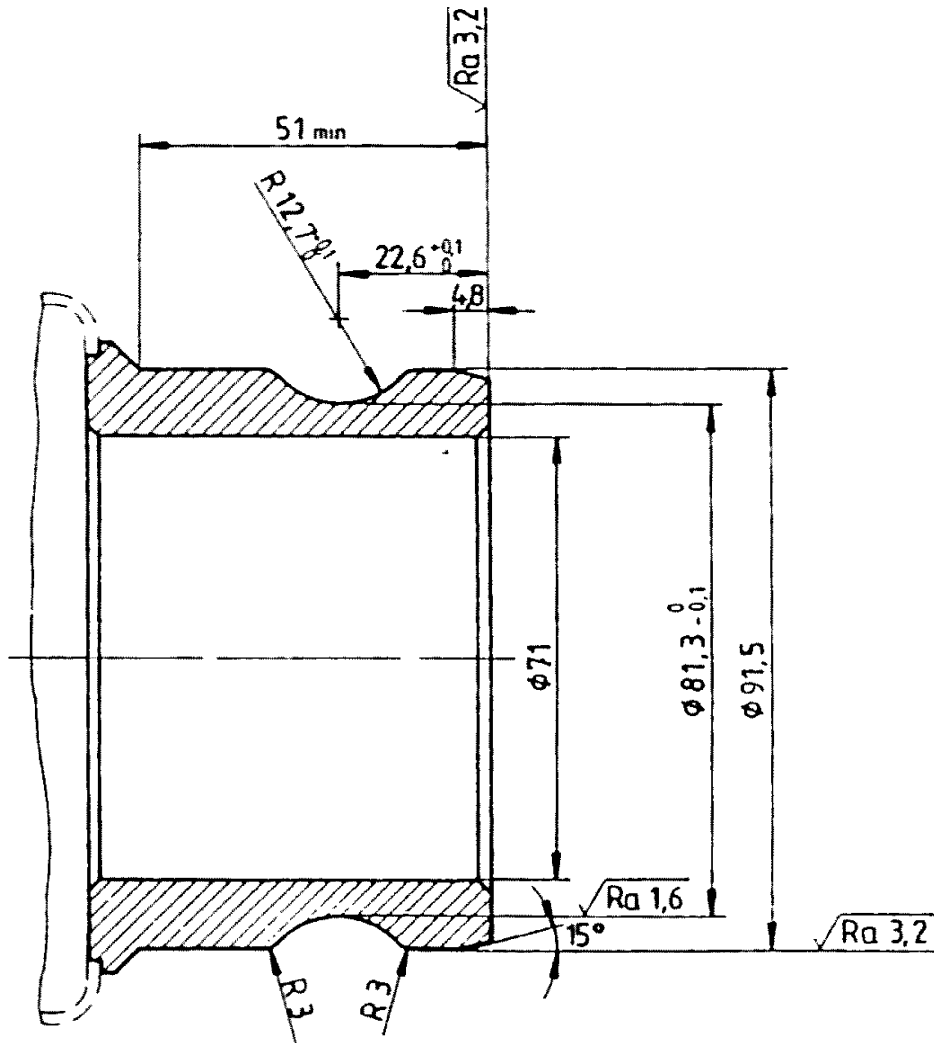
General tolerances $\pm 0,1$

Material: stainless steel

▼B

Figure G2

Optional flushing connection for the toilet tank (Inner part)

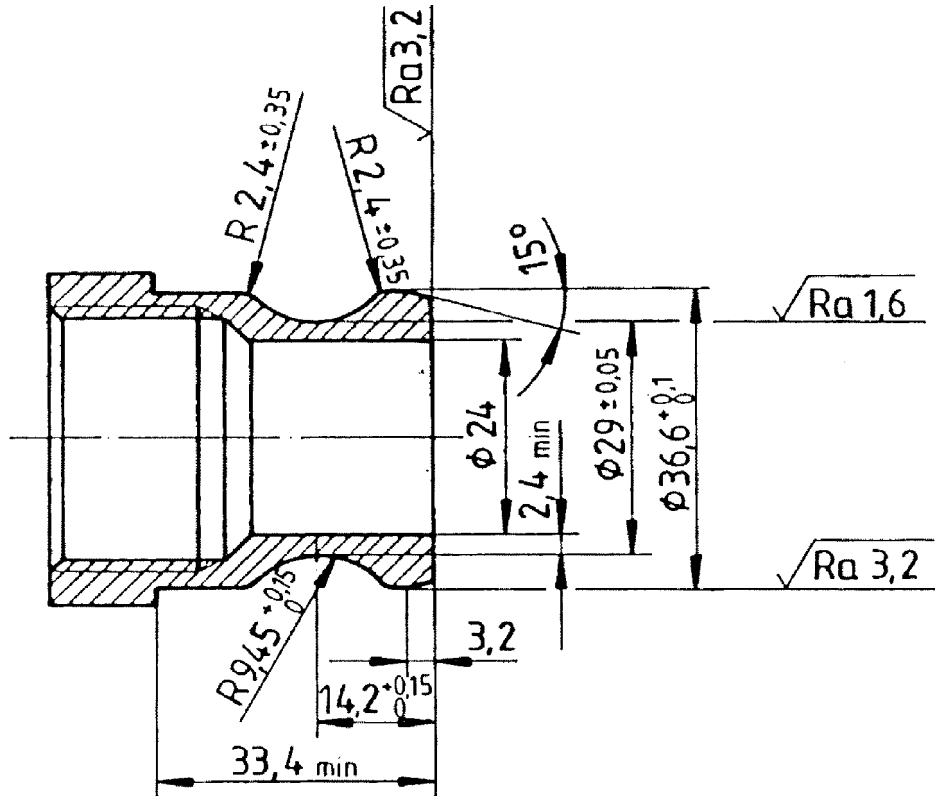
General tolerances $\pm 0,1$

Material: stainless steel



Appendix H

Assessment of the rolling stock subsystem

H.1 Scope

This Appendix indicates the assessment of conformity of the rolling stock subsystem.

H.2 Characteristics and modules

The sub-system characteristics to be assessed in the different phases of design, development and production are marked by X in Table H.1. A cross in column 4 of Table H.1 indicates that the relevant characteristics shall be verified by testing each single subsystem.

Table H.1

Assessment of the rolling stock subsystem

1		2	3	4	5
Characteristics to be assessed, as specified in clause 4.2 of this TSI		Design and development phase		Production phase	Particular assessment procedure
		Design review	Type Test	Routine Test	
Element of the Rolling Stock sub-system	Clause				Clause
Structure and mechanical parts	4.2.2				
Inner coupling	4.2.2.2.2	X	n.a.	n.a.	—
End coupling	4.2.2.2.3	X	n.a.	n.a.	—
IC automatic centre buffer coupler	5.3.1	X	X	X	—
IC manual end coupling	5.3.2	X	X	X	—
Rescue coupling	4.2.2.2.4	X	X	n.a.	—
IC rescue coupling	5.3.3	X	X	X	—
Staff access for coupling and uncoupling	4.2.2.2.5	X	X	n.a.	—
Gangways	4.2.2.3	X	X	n.a.	—
Strength of vehicle structure	4.2.2.4	X	X	n.a.	—
Passive safety	4.2.2.5	X	X	n.a.	—
Lifting and jacking	4.2.2.6	X	X	n.a.	—
Fixing of devices to carbody structure	4.2.2.7	X	n.a.	n.a.	—
Staff and freight access doors	4.2.2.8	X	X	n.a.	—
Mechanical characteristics of glass	4.2.2.9	X	n.a.	n.a.	—
Load conditions and weighted mass	4.2.2.10	X	X	X	6.2.3.1



1		2	3	4	5
Characteristics to be assessed, as specified in clause 4.2 of this TSI		Design and development phase		Production phase	Particular assessment procedure
		Design review	Type Test	Routine Test	
Element of the Rolling Stock sub-system	Clause				Clause
Track interaction and gauging	4.2.3				
Gauging	4.2.3.1	X	n.a.	n.a.	—
Wheel load	4.2.3.2.2	X	X	n.a.	6.2.3.2
Rolling Stock characteristics for compatibility with train detection systems	4.2.3.3.1	X	X	X	—
Axle bearing condition monitoring	4.2.3.3.2	X	X	n.a.	—
Safety against derailment running on twisted track	4.2.3.4.1	X	X	n.a.	6.2.3.3
Running dynamic behaviour requirements	4.2.3.4.2 (a)	X	X	n.a.	6.2.3.4
Active systems — safety requirement	4.2.3.4.2 (b)	X	n.a.	n.a.	6.2.3.5
Limit values for running safety	4.2.3.4.2.1	X	X	n.a.	6.2.3.4
Track loading limit values	4.2.3.4.2.2	X	X	n.a.	6.2.3.4
Equivalent conicity	4.2.3.4.3	X	n.a.	n.a.	—
Design values for new wheel profiles	4.2.3.4.3.1	X	n.a.	n.a.	6.2.3.6
In-service values of wheelset equivalent conicity	4.2.3.4.3.2	X			—
Structural design of bogie frame	4.2.3.5.1	X	X.	n.a.	—
Mechanical and geometrical characteristics of wheelsets	4.2.3.5.2.1	X	X	X	6.2.3.7
Mechanical and geometrical characteristics of wheels	4.2.3.5.2.2	X	X	X	—
Wheels (IC)	5.3.2	X	X	X	6.1.3.1
Variable gauge wheelsets	4.2.3.5.2.3	open	open	open	Open
Minimum curve radius	4.2.3.6	X	n.a.	n.a.	—
Life guards	4.2.3.7	X	n.a.	n.a.	—
Braking	4.2.4				
Functional requirements	4.2.4.2.1	X	X	n.a.	—
Safety requirements	4.2.4.2.2	X	n.a.	n.a.	6.2.3.5
Type of brake system	4.2.4.3	X	X	n.a.	—

▼B

1		2	3	4	5
Characteristics to be assessed, as specified in clause 4.2 of this TSI		Design and development phase		Production phase	Particular assessment procedure
		Design review	Type Test	Routine Test	
Element of the Rolling Stock sub-system	Clause				Clause
Brake command	4.2.4.4				
Emergency braking	4.2.4.4.1	X	X	X	—
Service braking	4.2.4.4.2	X	X	X	—
Direct braking command	4.2.4.4.3	X	X	X	—
Dynamic braking command	4.2.4.4.4	X	X	n.a	—
Parking braking command	4.2.4.4.5	X	X	X	—
Braking performance	4.2.4.5				
General requirements	4.2.4.5.1	X	n.a	n.a	—
Emergency braking	4.2.4.5.2	X	X	X	6.2.3.8
Service braking	4.2.4.5.3	X	X	X	6.2.3.9
Calculations related to thermal capacity	4.2.4.5.4	X	n.a	n.a	—
Parking brake	4.2.4.5.5	X	n.a	n.a	—
Limit of wheel rail adhesion profile	4.2.4.6.1	X	n.a	n.a	—
Wheel slide protection system	4.2.4.6.2	X	X	n.a	6.2.3.10
Wheel slide protection system (IC)	5.3.3	X	X	X	6.1.3.2
Interface with traction — Braking systems linked to traction (electric, hydro-dynamic)	4.2.4.7	X	X	X	—
Braking system independent of adhesion conditions	4.2.4.8				
General	4.2.4.8.1.	X	n.a	n.a	—
Magnetic track brake	4.2.4.8.2.	X	X	n.a	—
Eddy current track brake	4.2.4.8.3	open	Open	Open	Open
Brake state and fault indication	4.2.4.9	X	X	X	—
Brake requirements for rescue purposes	4.2.4.10	X	X	n.a	—
Passenger related items	4.2.5				
Sanitary systems	4.2.5.1	X	n.a	n.a	6.2.3.11
Public address system: audible communication system	4.2.5.2	X	X	X	—

▼B

1		2	3	4	5
Characteristics to be assessed, as specified in clause 4.2 of this TSI		Design and development phase		Production phase	Particular assessment procedure
		Design review	Type Test	Routine Test	
Element of the Rolling Stock sub-system	Clause				Clause
Passenger alarm	4.2.5.3	X	X	X	—
Passenger alarm — safety requir.	4.2.5.3	X	n.a	n.a	6.2.3.5
Communication devices for passengers	4.2.5.4	X	X	X	—
Exterior doors: access to and egress from Rolling Stock	4.2.5.5	X	X	X	—
Exterior doors — safety requir.	4.2.5.5	X	n.a	n.a	6.2.3.5
Exterior door system construction	4.2.5.6	X	n.a	n.a	—
inter-unit doors	4.2.5.7	X	X	n.a	—
Internal air quality	4.2.5.8	X	n.a	n.a	6.2.3.12
Body side windows	4.2.5.9	X			—
Environmental conditions and aerodynamic effects	4.2.6				
Environmental conditions	4.2.6.1				
Temperature	4.2.6.1.1	X	n.a. X ⁽¹⁾	n.a.	—
Snow, ice and hail	4.2.6.1.2	X	n.a. X ⁽¹⁾	n.a.	—
Aerodynamic effects	4.2.6.2				
Slipstream effects on passengers on platform and on workers trackside	4.2.6.2.1	X	X	n.a.	6.2.3.13
Head pressure pulse	4.2.6.2.2	X	X	n.a.	6.2.3.14
Maximum pressure variations in tunnels	4.2.6.2.3	X	X	n.a.	6.2.3.15
Cross wind	4.2.6.2.4	X	n.a	n.a.	6.2.3.16
External lights & visible and audible warning devices	4.2.7				
External front and rear lights	4.2.7.1				
Head lights IC	4.2.7.1.1 5.3.6	X	X	n.a	— 6.1.3.3
Marker lights IC	4.2.7.1.2 5.3.7	X	X	n.a	— 6.1. 3.4
Tail lights IC	4.2.7.1.3 5.3.8	X	X	n.a	— 6.1.3.5
Lamp controls	4.2.7.1.4	X	X	n.a	—



1		2	3	4	5
Characteristics to be assessed, as specified in clause 4.2 of this TSI		Design and development phase		Production phase	Particular assessment procedure
		Design review	Type Test	Routine Test	
Element of the Rolling Stock sub-system	Clause				Clause
Horn	4.2.7.2				
General — warning sound IC	4.2.7.2.1 5.3.9	X	X	n.a	— 6.1.3.6
Warning horn sound pressure levels	4.2.7.2.2 5.3.9	X	X	n.a	6.2.3.17 6.1.3.6
Protection	4.2.7.2.3	X	n.a	n.a	—
Control	4.2.7.2.4	X	X	n.a	—
Traction and electrical equipment	4.2.8				
Traction performance	4.2.8.1				
General	4.2.8.1.1				
Requirements on performance	4.2.8.1.2	X	n.a	n.a	—
Power supply	4.2.8.2				
General	4.2.8.2.1	X	n.a	n.a	—
Operation within range of voltages and frequencies	4.2.8.2.2	X	X	n.a	—
Regenerative brake with energy to the overhead contact line	4.2.8.2.3	X	X	n.a	—
Maximum power and current from the overhead contact line	4.2.8.2.4	X	X	n.a	6.2.3.18
Maximum current at standstill for DC systems	4.2.8.2.5	X	X	n.a	—
Power factor	4.2.8.2.6	X	X	n.a	6.2.3.19
System energy disturbances	4.2.8.2.7	X	X	n.a	—
Energy consumption measuring function	4.2.8.2.8	X	X	n.a	—
Requirements linked to pantograph	4.2.8.2.9	X	X	n.a	6.2.3.20 & 21
Pantograph (IC)	5.3.10	X	X	X	6.1.3.7
Contact strips (IC)	5.3.11	X	X	X	6.1.3.8
Electrical protection of the train IC Main circuit breaker	4.2.8.2.10 5.3.12	X	X	n.a	—
Diesel and other thermal traction system	4.2.8.3	—	—	—	Other Directive
Protection against electrical hazards	4.2.8.4	X	X	n.a	—

▼B

1		2	3	4	5
Characteristics to be assessed, as specified in clause 4.2 of this TSI		Design and development phase		Production phase	Particular assessment procedure
		Design review	Type Test	Routine Test	
Element of the Rolling Stock sub-system	Clause				Clause
Cab and operation	4.2.9				
Driver's Cab	4.2.9.1	X	n.a	n.a	—
General	4.2.9.1.1	X	n.a	n.a	—
Access and egress	4.2.9.1.2	X	n.a	n.a	—
Access and egress in operating conditions	4.2.9.1.2.1	X	n.a	n.a	—
Driver's cab emergency exit	4.2.9.1.2.2	X	n.a	n.a	—
External visibility	4.2.9.1.3	X	n.a	n.a	—
Front visibility	4.2.9.1.3.1	X	n.a	n.a	—
Rear and side view	4.2.9.1.3.2	X	n.a	n.a	—
Interior layout	4.2.9.1.4	X	n.a	n.a	—
Driver's seat	4.2.9.1.5	X	n.a	n.a	—
IC	5.3.13	X	X	X	—
Driver's desk- Ergonomics	4.2.9.1.6	X	n.a	n.a	—
Climate control and air quality	4.2.9.1.7	X	X	n.a	6.2.3.12
Internal lighting	4.2.9.1.8	X	X	n.a	—
Windscreen-Mechanical characteristics	4.2.9.2.1	X	X	n.a	6.2.3.22
Windscreen-Optical characteristics	4.2.9.2.2	X	X	n.a	6.2.3.22
Windscreen-Equipment	4.2.9.2.3	X	X	n.a	—
Driver machine interface	4.2.9.3				
Driver's activity control function	4.2.9.3.1	X	X	X	—
Speed indication	4.2.9.3.2	—	—	—	—
Driver display unit and screens	4.2.9.3.3	X	X	n.a	—
Controls and indicators	4.2.9.3.4	X	X	n.a	—
Labelling	4.2.9.3.5	X	n.a	n.a	—
Radio remote control function by staff for shunting operation	4.2.9.3.6	X	X	n.a	—
Onboard tools and portable equipment	4.2.9.4	X	n.a	n.a	—
Storage facility for staff personal effects	4.2.9.5	X	n.a	n.a	—

▼ **B**

1		2	3	4	5
Characteristics to be assessed, as specified in clause 4.2 of this TSI		Design and development phase		Production phase	Particular assessment procedure
		Design review	Type Test	Routine Test	
Element of the Rolling Stock sub-system	Clause				Clause
Recording device	4.2.9.6	X	X	X	—
Fire safety and evacuation	4.2.10				
General and categorisation	4.2.10.1	X	n.a	n.a	—
Mesures to prevent fire	4.2.10.2	X	X	n.a	—
Mesures to detect/control fire	4.2.10.3	X	X	n.a	—
Requirements related to emergencies	4.2.10.4	X	X	n.a	—
Requirements related to evacuation	4.2.10.5	X	X	n.a	—
Servicing	4.2.11				
Cleaning of driver's cab windscreen	4.2.11.2	X	X	n.a	—
Connection to toilet discharge system IC	4.2.11.3 5.3.14	X	n.a	n.a	—
Water refilling equipment	4.2.11.4	X	n.a	n.a	—
Interface for water refilling IC	4.2.11.5 5.3.15	X	n.a	n.a	—
Special requirements for stabling of trains	4.2.11.6	X	X	n.a	—
Refuelling equipment	4.2.11.7	X	n.a	n.a	—
Train interior cleaning — power supply	4.2.11.8	X	n.a	n.a	—
Documentation for operation and maintenance	4.2.12				
General	4.2.12.1	X	n.a	n.a	—
General documentation	4.2.12.2	X	n.a	n.a	—
Documentation related to maintenance	4.2.12.3	X	n.a	n.a	—
The maintenance design justification file	4.2.12.3.1	X	n.a	n.a	—
The Maintenance description file	4.2.12.3.2	X	n.a	n.a	—
Operating documentation	4.2.12.4	X	n.a	n.a	—
Lifting diagram and instructions	4.2.12.4	X	n.a	n.a	—
Rescue related descriptions	4.2.12.5	X	n.a	n.a	—

(¹) Type test if and as defined by the Applicant.



Appendix I

Aspects for which the technical specification is not available (open points)

Open points that relate to technical compatibility between the vehicle and the network:

Element of the Rolling Stock sub-system	Clause of this TSI	Technical aspect not covered by this TSI	Comments
Compatibility with train detection systems	4.2.3.3.1	See specification referenced in Annex J-2, index 1.	Open points also identified in the TSI CCS.
Running dynamic behaviour for 1 520 mm track gauge system	4.2.3.4.2 4.2.3.4.3	Running dynamic behaviour. Equivalent conicity.	Normative documents referred to in the TSI are based on experience gained on the 1 435 mm system.
Braking system independent of adhesion conditions	4.2.4.8.3	Eddy current track brake	Equipment not mandatory. Compatibility with concerned network to be checked.
Aerodynamic effects for 1 520 mm, 1 524 mm and 1 668 mm track gauge systems	4.2.6.2	Limit values and conformity assessment	Normative documents referred to in the TSI are based on experience gained on the 1 435 mm system.
Aerodynamic effect on ballasted track for RST of design speed \geq 190 km/h	4.2.6.2.5	Limit value and conformity assessment in order to limit risks induced by the projection of ballast	Ongoing work within CEN. Open point also in TSI INF.

Open points that do not relate to technical compatibility between the vehicle and the network:

Element of the Rolling Stock sub-system	Clause of this TSI	Technical aspect not covered by this TSI	Comments
Passive Safety	4.2.2.5	Application of scenarios 1 and 2 to locomotives with centre couplers and traction effort higher than 300 kN.	If no technical solution available, possible restrictions at the level of operation.
Variable gauge wheelsets	4.2.3.5.2.3	Conformity assessment	Design option.
On-board energy measurement system	4.2.8.2.8 and Appendix D	On-board to ground communication: specification related to interface protocols and transferred data format.	Description of on-board to ground communication shall be provided in the technical documentation. The standard series EN 61375-2-6 should be used.
Fire Containment and Control Systems	4.2.10.3.4	Conformity assessment of FCCS other than full partitions.	Assessment procedure of efficiency for controlling fire and smoke developed by CEN according to a request for standard issued by ERA.



Appendix J

Technical specifications referred to in this TSI

J.1 Standards or normative documents

Index No	TSI		Normative document	
	Characteristics to be assessed	Point	Document No	Mandatory points
1	Inner coupling for articulated units	4.2.2.2.2	EN 12663-1:2010	6.5.3, 6.7.5
2	End coupling — manual UIC type — pipes interface	4.2.2.2.3	EN 15807:2012	relevant cl. (1)
3	End coupling — manual UIC type — end cocks	4.2.2.2.3	EN 14601:2005 +A1:2010	relevant cl. (1)
4	End coupling — manual UIC type — lateral location of brake pipe and cocks	4.2.2.2.3	UIC 648:Sept 2001	relevant cl. (1)
5	Rescue coupling — interface with recovery unit	4.2.2.2.4	UIC 648:Sept 2001	relevant cl. (1)
6	Staff access for coupling and uncoupling — space for shunting staff	4.2.2.2.5	EN 16116-1:2013	6.2
7	Strength of vehicle structure — general categorisation of rolling stock method of verification	4.2.2.4 Appendix C C	EN 12663-1:2010	relevant cl. (1) 5.2 9.2 6.1 – 6.5
8	Passive safety — general categorisation scenarios obstacle deflector	4.2.2.5	EN 15227:2008 +A1:2011	Except Annex A 4—table 1 5—table 2, 6 5—table 3, 6.5
9	Lifting and jacking — geometry of permanent and removable points	4.2.2.6	EN 16404:2014	5.3, 5.4
10	Lifting and jacking — marking	4.2.2.6	EN 15877-2:2013	4.5.17
11	Lifting and jacking — strength method of verification	4.2.2.6	EN 12663-1:2010	6.3.2, 6.3.3, 9.2
12	Fixing of devices to carbody structure	4.2.2.7	EN 12663-1:2010	6.5.2
13	Load conditions and weighed mass — load conditions hypothesis of load conditions	4.2.2.10	EN 15663:2009 /AC:2010	2.1 relevant cl. (1)

▼B

Index No	TSI		Normative document	
	Characteristics to be assessed	Point	Document No	Mandatory points
14	Gauging — method, reference contours verification of pantograph gauge	4.2.3.1	EN 15273-2:2013	relevant cl. (1) A.3.12
15	Axle bearing condition monitoring — zone visible to track side equipment	4.2.3.3.2.2	EN 15437-1:2009	5.1, 5.2
16	Running dynamic behaviour	4.2.3.4.2 Appendix C	EN 14363:2005	relevant cl. (1)
17	Running dynamic behaviour — limit values for running safety	4.2.3.4.2.1	EN 14363:2005	5.3.2.2
18	Running dynamic behaviour — for rolling stock with a cant deficiency > 165 mm	4.2.3.4.2.1	EN 15686:2010	relevant cl. (1)
19	Running dynamic behaviour — track loading limit values	4.2.3.4.2.2	EN 14363:2005	5.3.2.3
20	Structural design of the bogie frame	4.2.3.5.1	EN 13749:2011	6.2, Annex C
21	Structural design of the bogie frame — body to bogie connection	4.2.3.5.1	EN 12663-1:2010	relevant cl. (1)
22	Braking — type of brake system, UIC brake system	4.2.4.3	EN 14198:2004	5.4
23	Braking performance — calculation — general	4.2.4.5.1	EN 14531-1:2005 or EN 14531-6:2009	relevant cl. (1)
24	Braking performance — friction coefficient	4.2.4.5.1	EN 14531-1:2005	5.3.1.4
25	Emergency braking performance — response time/delay time brake weight percentage	4.2.4.5.2	EN 14531-1:2005	5.3.3 5.12
26	Emergency braking performance — calculation	4.2.4.5.2	EN 14531-1:2005 or EN 14531-6:2009	relevant cl. (1)
27	Emergency braking performance — friction coefficient	4.2.4.5.2	EN 14531-1:2005	5.3.1.4
28	Service braking performance — calculation	4.2.4.5.3	EN 14531-1:2005 or EN 14531-6:2009	relevant cl. (1)

▼B

Index No	TSI		Normative document	
	Characteristics to be assessed	Point	Document No	Mandatory points
29	Parking brake performance — calculation	4.2.4.5.5	EN 14531-1:2005 or EN 14531-6:2009	relevant cl. (1)
30	Wheel slide protection system — design verification method wheel rotation monitoring system	4.2.4.6.2	EN 15595:2009	4 5, 6 4.2.4.3
31	Magnetic track brake	4.2.4.8.2	UIC 541-06:Jan 1992	Appendix 3
32	Door obstacle detection — sensitivity maximum force	4.2.5.5.3	FprEN 14752:2014	5.2.1.4.1 5.2.1.4.2.2
33	Door emergency opening — manual force to open the door	4.2.5.5.9	FprEN 14752:2014	5.5.1.5
34	Environmental conditions — temperature	4.2.6.1.1	EN 50125-1:2014	4.3
35	Environmental conditions — snow, ice and hail conditions	4.2.6.1.2	EN 50125-1:2014	4.7
36	Environmental conditions — obstacle deflector	4.2.6.1.2	EN 15227:2008 +A1:2011	relevant cl. (1)
37	Aerodynamic effects — crosswind method of verification	4.2.6.2.4	EN 14067-6:2010	5
38	Head lights — colour dimmed headlamp luminous intensity full-beam headlamp luminous intensity alignment	4.2.7.1.1	EN 15153-1:2013	5.3.3 5.3.4 Table 2 first line 5.3.4 Table 2 first line 5.3.5
39	Marker lights — colour spectral radiation distribution luminous intensity	4.2.7.1.2	EN 15153-1:2013	5.4.3.1 Table 4 5.4.3.2 5.4.4 Table 6
40	Tail lights — colour luminous intensity	4.2.7.1.3	EN 15153-1:2013	5.5.3 Table 7 5.5.4 Table 8
41	Warning horn sound pressure levels	4.2.7.2.2	EN 15153-2:2013	5.2.2
42	Regenerative brake with energy to the overhead contact line	4.2.8.2.3	EN 50388:2012	12.1.1
43	Maximum power and current from the overhead contact line — automatic regulation of current	4.2.8.2.4	EN 50388:2012	7.2

▼B

Index No	TSI		Normative document	
	Characteristics to be assessed	Point	Document No	Mandatory points
44	Power factor — verification method	4.2.8.2.6	EN 50388:2012	6
45	System energy disturbances for AC systems — harmonics and dynamic effects compatibility study	4.2.8.2.7	EN 50388:2012	10.1 10.3 Table 5 Annex D 10.4
46	Working range in height of pantograph (IC level) — characteristics	4.2.8.2.9.1.2	EN 50206-1:2010	4.2, 6.2.3
47	Pantograph head geometry	4.2.8.2.9.2	EN 50367:2012	5.3.2.2
48	Pantograph head geometry — type 1600 mm	4.2.8.2.9.2.1	EN 50367:2012	Annex A.2 Figure A.6
49	Pantograph head geometry — type 1950 mm	4.2.8.2.9.2.2	EN 50367:2012	Annex A.2 Figure A.7
50	Pantograph current capacity (IC level)	4.2.8.2.9.3	EN 50206-1:2010	6.13.2
51	Pantograph lowering (RST level) — time to lower the pantograph ADD	4.2.8.2.9.10	EN 50206-1:2010	4.7 4.8
52	Pantograph lowering (RST level) — dynamic insulating distance	4.2.8.2.9.10	EN 50119:2009	Table 2
53	Electrical protection of the train — coordination of protection	4.2.8.2.10	EN 50388:2012	11
54	Protection against electrical hazard	4.2.8.4	EN 50153:2002	relevant cl. (1)
55	Windscreen — mechanical characteristics	4.2.9.2.1	EN 15152:2007	4.2.7, 4.2.9
56	Windscreen — primary/secondary images optical distortion haze luminous transmittance chromaticity	4.2.9.2.2	EN 15152:2007	4.2.2 4.2.3 4.2.4 4.2.5 4.2.6
57	Recording device — functional requirements recording performance integrity data integrity safeguard level of protection	4.2.9.6	EN/IEC 62625-1:2013	4.2.1, 4.2.2, 4.2.3, 4.2.4 4.3.1.2.2 4.3.1.4 4.3.1.5 4.3.1.7
58	Measures to prevent fire — material requirements	4.2.10.2.1	EN 45545-2:2013	relevant cl. (1)

▼B

Index No	TSI		Normative document	
	Characteristics to be assessed	Point	Document No	Mandatory points
59	Specific measures for flammable liquids	4.2.10.2.2	EN 45545-2:2013	Table 5
60	Fire spreading protection measures for passenger rolling stock — partition test	4.2.10.3.4	EN 1363-1:2012	relevant cl. (1)
61	Fire spreading protection measures for passenger rolling stock — partition test	4.2.10.3.5	EN 1363-1:2012	relevant cl. (1)
62	Emergency lighting — lighting level	4.2.10.4.1	EN 13272:2012	5.3
63	Running capability	4.2.10.4.4	EN 50553:2012	relevant cl. (1)
64	Interface for water filling	4.2.11.5	EN 16362:2013	4.1.2 figure 1
65	Special requirements for stabling of trains — local extranla auxiliary power supply	4.2.11.6	EN/IEC 60309-2:1999	relevant cl. (1)
66	Automatic centre buffer coupler — type 10	5.3.1	EN 16019:2014	relevant cl. (1)
67	Manual end coupling — UIC type	5.3.2	EN 15551:2009	relevant cl. (1)
68	Manual end coupling — UIC type	5.3.2	EN 15566:2009	relevant cl. (1)
69	Rescue coupler	5.3.3	EN 15020:2006 +A1:2010	relevant cl. (1)
70	Main circuit breaker — coordination of protection	5.3.12	EN 50388:2012	11
71	Wheels — verification method decision criteria further verification method thermomechanical behaviour	6.1.3.1	EN 13979-1:2003 +A2:2011	7.2.1, 7.2.2 7.2.3 7.3 6
72	Wheel slide protection — method of verification test programme	6.1.3.2	EN 15595:2009	5 only 6.2.3 of 6.2
73	Head lamps — colour luminous intensity	6.1.3.3	EN 15153-1:2013	6.3 6.4
74	Marker lamps — colour luminous intensity	6.1.3.4	EN 15153-1:2013	6.3 6.4
75	Tail lamps — colour luminous intensity	6.1.3.5	EN 15153-1:2013	6.3 6.4
76	Horn — sounding sound pressure level	6.1.3.6	EN 15153-2:2013	6 6

▼B

Index No	TSI		Normative document	
	Characteristics to be assessed	Point	Document No	Mandatory points
77	Pantograph — static contact force	6.1.3.7	EN 50367:2012	7.2
78	Pantograph — limit value	6.1.3.7	EN 50119:2009	5.1.2
79	Pantograph — verification method	6.1.3.7	EN 50206-1:2010	6.3.1
80	Pantograph — dynamic behaviour	6.1.3.7	EN 50318:2002	relevant cl. (1)
81	Pantograph — interaction characteristics	6.1.3.7	EN 50317:2012	relevant cl. (1)
82	Contact strips — verification method	6.1.3.8	EN 50405:2006	5.2.2, 5.2.3, 5.2.4, 5.2.6, 5.2.7
83	Safety against derailment running on twisted track	6.2.3.3	EN 14363:2005	4.1
84	Running dynamic behaviour — method of verification assessment of criteria conditions of assessment	6.2.3.4	EN 14363:2005	5 relevant cl. (1) relevant cl. (1)
85	Equivalent conicity — rail section definitions	6.2.3.6	EN 13674-1:2011	relevant cl. (1)
86	Equivalent conicity — wheel profile definitions	6.2.3.6	EN 13715:2006	relevant cl. (1)
87	Wheelset — assembly	6.2.3.7	EN 13260:2009 +A1:2010 +A2:2012	3.2.1
88	Wheelset — axles, method of verification decision criteria	6.2.3.7	EN 13103:2009 +A1:2010 +A2:2012	4, 5, 6 7
89	Wheelset — axles, method of verification decision criteria	6.2.3.7	EN 13104:2009 +A1:2010	4, 5, 6 7
90	Axle boxes/bearings	6.2.3.7	EN 12082:2007	6
91	Emergency braking performance	6.2.3.8	EN 14531-1:2005	5.11.3
92	Service braking performance	6.2.3.9	EN 14531-1:2005	5.11.3
93	Wheel slide protection, method of verification of performance	6.2.3.10	EN 15595:2009	6.4

▼ B

Index No	TSI		Normative document	
	Characteristics to be assessed	Point	Document No	Mandatory points
94	Slipstream effect — meteorological conditions, sensors, sensor accuracy, selection of valid data and processing of the data	6.2.3.13	EN 14067-4:2005 +A1:2009	8.5.2
95	Head pressure pulse — method of verification CFD Moving model	6.2.3.14	EN 14067-4:2005 +A1:2009	5.5.2 5.3 5.4.3
96	Maximum pressure variations — distance xp between the entrance portal and the measuring position, the definitions of ΔpFr , ΔpN , ΔpT , the minimum tunnel length	6.2.3.15	EN 14067-5:2006 +A1:2010	relevant cl. (1)
97	Horn — sound pressure level	6.2.3.17	EN 15153-2:2013	5
98	Maximum power and current from the overhead contact line — method of verification	6.2.3.18	EN 50388:2012	15.3
99	Power factor — method of verification	6.2.3.19	EN 50388:2012	15.2
100	Current collection dynamic behaviour — dynamic tests	6.2.3.20	EN 50317:2012	relevant cl. (1)
101	Windscreen — characteristics	6.2.3.22	EN 15152:2007	6.2.1 to 6.2.7
102	Structural strength	Annex C.1	EN 12663-2:2010	5.2.1-5.2.4
103	On-board energy measurement system	Annex D	EN 50463-2:2012	relevant cl. (1)
104	On-board energy measurement system	Annex D	EN 50463-3:2012	relevant cl. (1)
105	On-board energy measurement system	Annex D	EN 50463-5:2012	relevant cl. (1)

(1) Clauses of the standard that are in direct relationship to the requirement expressed in the clause of the TSI indicated in column 3.

J.2 Technical documents (available on ERA website)

Index No	TSI		ERA technical document	
	Characteristics to be assessed	Point	Mandatory ref Document No	Points
1	Interface between control-command signalling trackside and other subsystems	4.2.3.3.1	ERA/ERTMS/033281 rev 2.0	3.1 & 3.2
2	Rolling stock dynamic behaviour	4.2.3.4	ERA/TD/2012-17/INT rev 3.0	All