

Commission Delegated Regulation (EU) No 134/2014 of 16 December 2013 supplementing Regulation (EU) No 168/2013 of the European Parliament and of the Council with regard to environmental and propulsion unit performance requirements and amending Annex V thereof (Text with EEA relevance)

COMMISSION DELEGATED REGULATION (EU) No 134/2014

of 16 December 2013

supplementing Regulation (EU) No 168/2013 of the European Parliament and of the Council with regard to environmental and propulsion unit performance requirements and amending Annex V thereof

(Text with EEA relevance)

THE EUROPEAN COMMISSION,

Having regard to the Treaty on the Functioning of the European Union,

Having regard to Regulation (EU) No 168/2013 of the European Parliament and of the Council of 15 January 2013 on the approval and market surveillance of two- or three-wheel vehicles and quadricycles⁽¹⁾, and in particular Article 18(3), Article 23(12), Article 24(3) and Article 74 thereof,

Whereas:

- (1) The term ‘L-category vehicles’ covers a wide range of light vehicle types with two, three or four wheels, e.g. powered cycles, two- and three-wheel mopeds, two- and three-wheel motorcycles, motorcycles with side-cars and light four-wheel vehicles (quadricycles) such as on-road quads, all-terrain quads and quadrimobiles.
- (2) Regulation (EU) No 168/2013 provides for the possibility of applying regulations of the United Nations Economic Commission for Europe (UNECE) for the purpose of EU whole vehicle type-approval. Under that Regulation, type-approval in accordance with UNECE regulations which apply on a compulsory basis is regarded as EU type-approval.
- (3) The compulsory application of UNECE regulations helps avoiding duplication not only of technical requirements but also of certification and administrative procedures. In addition, type-approval that is directly based on internationally agreed standards could improve market access in third countries, in particular those which are contracting parties to the Agreement of the United Nations Economic Commission for Europe concerning the adoption of uniform technical prescriptions for wheeled vehicles, equipment and parts which can be fitted to or be used on wheeled vehicles and the conditions for reciprocal recognition of approvals granted on the basis of these prescriptions (‘Revised 1958 Agreement’), acceded by the Union by Council Decision 97/836/EC⁽²⁾, and thus enhance the Union industry’s competitiveness. However, to date the available UNECE regulations are either outdated or not existing and therefore these are revisited and upgraded for technical progress.

Status: Point in time view as at 16/12/2013.

Changes to legislation: There are currently no known outstanding effects for the Commission Delegated Regulation (EU) No 134/2014. (See end of Document for details)

- (4) Therefore, Regulation (EU) No 168/2013 provides for the repeal of several directives concerning the approval of L-category vehicles, their systems, components and separate technical units intended for those vehicles in the areas of environmental and propulsion unit performance requirements. For the purposes of EU type-approval those directives should be replaced first with the provisions of this Regulation. On the long term, when the revisiting process at the level of the UN is finished, equivalent UNECE regulations will be available, which then will allow to replace the text of this Regulation with making reference to those UNECE regulations.
- (5) In particular UNECE regulation No 41 on noise emissions of categories L3e and L4e motorcycles was updated in 2011 for technical progress. UNECE regulation No 41 should therefore be made obligatory in EU type-approval legislation and replace Annex III to Chapter 9 of Directive 97/24/EC of the European Parliament and of the Council⁽³⁾ in order for motorcycles to comply with only one set of motorcycle sound requirements, which are world-wide accepted by the contracting parties to the Revised 1958 Agreement. UNECE regulation No 85 on measurement of net power of electric motors should also be made obligatory with the same objective of mutual recognition between the contracting parties to the Revised 1958 Agreement in the area of propulsion unit performance requirements for electric motors.
- (6) The Euro 4 and 5 environmental steps are such measures designed to reduce emissions of particulate matter and ozone precursors such as nitrogen oxides and hydrocarbons. A considerable reduction in hydrocarbon emissions from L-category vehicles is necessary to improve air quality and comply The exhaust system which is granted system type-approval with limit values for pollution, not only directly to significantly reduce the disproportionately high hydrocarbon tailpipe and evaporative emissions from these vehicles, but also to help reduce volatile particle levels in urban areas and possibly also smog.
- (7) One of the measures against excessive hydrocarbon emissions from L-category vehicles is to limit the evaporative emissions to the hydrocarbon mass limits laid down in Annex VI(C) to Regulation (EU) No 168/2013. For this purpose, a type IV test has to be conducted at type-approval in order to measure the evaporative emissions of a vehicle. One of the requirements of the type IV Sealed House evaporative Emission Determination (SHED) test is to fit either a rapidly aged carbon canister or alternatively to apply an additive deterioration factor when fitting a degreened carbon canister. It will be investigated in the environmental effect study referred to in Article 23(4) of Regulation (EU) No 168/2013 whether or not it is cost effective to maintain this deterioration factor as alternative to fitting a representative and rapidly aged carbon canister. If the result of the study demonstrates that this method is not cost-effective a proposal will follow in due course to delete this alternative and should become applicable beyond the Euro 5 step.
- (8) A standardised method for measuring vehicles' energy efficiency (fuel or energy consumption, carbon dioxide emissions as well as electric range) is necessary to ensure that no technical barriers to trade arise between Member States and also to ensure that customers and users are supplied with objective and precise information.

Status: Point in time view as at 16/12/2013.

Changes to legislation: There are currently no known outstanding effects for the Commission Delegated Regulation (EU) No 134/2014. (See end of Document for details)

- (9) The methods for measuring propulsion unit performance including the maximum design vehicle speed, maximum torque and maximum continuous total power of L-category vehicles may differ from one Member State to the next, this might constitute barriers to trade within the Union. Therefore, it is necessary to draw up harmonised requirements for methods for measuring the propulsion unit performance of L-category vehicles in order to enable the approval of vehicles, systems, components or separate technical units to be applied for each type of such vehicle.
- (10) Functional safety or environmental requirements call for restrictions on tampering with certain types of L-category vehicles. In order to avoid obstacles to servicing and maintenance by vehicle owners, such restrictions should be strictly limited to tampering which significantly modifies the environmental and propulsion unit performance of the vehicle and functional safety in a harmful way. As harmful tampering of the vehicle's powertrain affects both the environmental and functional safety performance, the detailed requirements regarding propulsion unit performance and noise abatement set out in this Regulation should also be used as reference for enforcement of powertrain tampering prevention.
- (11) Part A of Annex V to Regulation (EU) No 168/2013 makes reference to the 8 test types that allow assessment of the environmental performance of the L-category vehicle to be approved. It is appropriate to set out detailed test requirements in this delegated act as well as to amend Annex V (A) of Regulation (EU) No 168/2013 by linking the test limits agreed by Council and the European Parliament with detailed test procedures and technical requirements set out in this Regulation. A reference to the detailed test procedures and requirements set out in this Regulation should be inserted into Part A of Annex V to Regulation (EU) No 168/2013 by means of the amendments set out in Annex XII of this Regulation.

HAS ADOPTED THIS REGULATION:

CHAPTER I

SUBJECT MATTER AND DEFINITIONS

Article 1

Subject matter

This Regulation establishes the detailed technical requirements and test procedures regarding environmental and propulsion unit performance for the approval of L-category vehicles and the systems, components and separate technical units intended for such vehicles in accordance with Regulation (EU) No 168/2013 and sets out a list of UNECE regulations and amendments thereto.

Status: Point in time view as at 16/12/2013.

Changes to legislation: There are currently no known outstanding effects for the Commission Delegated Regulation (EU) No 134/2014. (See end of Document for details)

Article 2

Definitions

The definitions of Regulation (EU) No 168/2013 shall apply. In addition, the following definitions shall apply:

- (1) ‘WMTC stage 1’ refers to the World harmonised Motorcycle Test Cycle laid down in UNECE Global Technical Regulation No 2⁽⁴⁾ used as alternative type I emission test cycle to the European Driving Cycle as of 2006 for category L3e motorcycle types;
- (2) ‘WMTC stage 2’ refers to the World harmonised Motorcycle Test Cycle laid down in the amended UNECE Global Technical Regulation No 2⁽⁵⁾ which is used as compulsory type I emission test cycle in the approval of Euro 4 compliant (sub-)categories L3e, L4e, L5e-A and L7e-A vehicles;
- (3) ‘WMTC stage 3’ refers to the revised WMTC referred to in Annex VI(A) of Regulation (EU) No 168/2013 and is equal to the World harmonised Motorcycle Test Cycle laid down in the amended UNECE Global Technical Regulation No 2⁽⁶⁾ and adapted for vehicles with a low maximum design vehicle speed, which is used as the compulsory type I emission test cycle in the approval of Euro 5 compliant L-category vehicles;
- (4) ‘maximum design vehicle speed’ means the maximum speed of the vehicle determined in accordance with Article 15 of this Regulation;
- (5) ‘exhaust emissions’ means tailpipe emissions of gaseous pollutants and particulate matter;
- (6) ‘particulate filter’ means a filtering device fitted in the exhaust system of a vehicle to reduce particulate matter from the exhaust flow;
- (7) ‘properly maintained and used’ means that when selecting a test vehicle it satisfies the criteria with regard to a good level of maintenance and normal use according to the recommendations of the vehicle manufacturer for acceptance of such a test vehicle;
- (8) ‘fuel requirement’ by the engine means the type of fuel normally used by the engine:
 - (a) petrol (E5);
 - (b) liquefied petroleum gas (LPG);
 - (c) NG/biomethane (natural gas);
 - (d) either petrol (E5) or LPG;
 - (e) either petrol (E5) or NG/biomethane;
 - (f) diesel fuel (B5);
 - (g) mixture of ethanol (E85) and petrol (E5) (flex fuel);
 - (h) mixture of biodiesel and diesel (B5) (flex fuel);
 - (i) hydrogen (H₂) or a mixture (H₂NG) of NG/biomethane and hydrogen;
 - (j) either petrol (E5) or hydrogen (bi-fuel);

- (9) ‘environmental performance type-approval’ of a vehicle means the approval of a vehicle type, variant or version with regard to the following conditions:
- (a) complying with Parts A and B of Annex V to Regulation (EU) No 168/2013;
 - (b) falling into one propulsion family according to the criteria set out in Annex XI;
- (10) ‘vehicle type with regard to environmental performance’ means a set of L-category vehicles which do not differ in the following:
- (a) the equivalent inertia determined in relation to the reference mass, in accordance with Appendices 5, 7 or 8 to Annex II;
 - (b) the propulsion characteristics set out in Annex XI regarding propulsion family;
- (11) ‘periodically regenerating system’ means a pollution control device such as a catalytic converter, particulate filter or any other pollution control device that requires a periodical regeneration process in less than 4 000 km of normal vehicle operation;
- (12) ‘alternative fuel vehicle’ means a vehicle designed to run on at least one type of fuel that is either gaseous at atmospheric temperature and pressure, or substantially non-mineral oil derived;
- (13) ‘flex fuel H₂NG vehicle’ means a flex fuel vehicle designed to run on different mixtures of hydrogen and natural gas or biomethane;
- (14) ‘parent vehicle’ means a vehicle that is representative of a propulsion family set out in Annex XI;
- (15) ‘pollution-control device type’ means a category of pollution-control devices that are used to control pollutant emissions and that do not differ in their essential environmental performance and design characteristics;
- (16) ‘catalytic converter’ means an emission pollution-control device which converts toxic by-products of combustion in the exhaust of an engine to less toxic substances by means of catalysed chemical reactions;
- (17) ‘catalytic converter type’ means a category of catalytic converters that do not differ as regards the following:
- (a) number of coated substrates, structure and material;
 - (b) type of catalytic activity (oxidising, three-way, or of another type of catalytic activity);
 - (c) volume, ratio of frontal area and substrate length;
 - (d) catalytic converter material content;
 - (e) catalytic converter material ratio;
 - (f) cell density;
 - (g) dimensions and shape;
 - (h) thermal protection;

Status: Point in time view as at 16/12/2013.

Changes to legislation: There are currently no known outstanding effects for the Commission Delegated Regulation (EU) No 134/2014. (See end of Document for details)

- (i) an inseparable exhaust manifold, catalytic converter and muffler integrated in the exhaust system of a vehicle or separable exhaust system units that can be replaced;
- (18) ‘reference mass’ means the mass in running order of the L-category vehicle determined in accordance with Article 5 of Regulation (EU) No 168/2013 increased with the mass of the driver (75 kg) and if applicable plus the mass of the propulsion battery;
- (19) ‘drive train’ means the part of the powertrain downstream of the output of the propulsion unit(s) that consists if applicable of the torque converter clutches, the transmission and its control, either a drive shaft or belt drive or chain drive, the differentials, the final drive, and the driven wheel tyre (radius);
- (20) ‘stop-start system’ means automatic stop and start of the propulsion unit to reduce the amount of idling, thereby reducing fuel consumption, pollutant and CO₂ emissions of the vehicle;
- (21) ‘powertrain software’ means a set of algorithms concerned with the operation of data processing in powertrain control units, propulsion control units or drive-train control units, containing an ordered sequence of instructions that change the state of the control units;
- (22) ‘powertrain calibration’ means the application of a specific set of data maps and parameters used by the control unit’s software to tune the vehicle’s powertrain, propulsion or drive train unit(s)’s control;
- (23) ‘powertrain control unit’ means a combined control unit of combustion engine(s), electric traction motors or drive train unit systems including the transmission or the clutch;
- (24) ‘engine control unit’ means the on-board computer that partly or entirely controls the engine or engines of the vehicle;
- (25) ‘drive train control unit’ means the on-board computer that partly or entirely controls the drive train of the vehicle;
- (26) ‘sensor’ means a converter that measures a physical quantity or state and converts it into an electric signal that is used as input to a control unit;
- (27) ‘actuator’ means a converter of an output signal from a control unit into motion, heat or other physical state in order to control the powertrain, engine(s) or drive train;
- (28) ‘carburettor’ means a device that blends fuel and air into a mixture that can be combusted in a combustion engine;
- (29) ‘scavenging port’ means a connector between crankcase and combustion chamber of a two-stroke engine through which the fresh charge of air, fuel and lubrication oil mixture enters the combustion chamber;
- (30) ‘air intake system’ means a system composed of components allowing the fresh-air charge or air-fuel mixture to enter the engine and includes, if fitted, the air filter, intake pipes, resonator(s), the throttle body and the intake manifold of an engine;
- (31) ‘turbocharger’ means an exhaust gas turbine-powered centrifugal compressor boosting the amount of air charge into the combustion engine, thereby increasing propulsion unit performance;

Status: Point in time view as at 16/12/2013.

Changes to legislation: There are currently no known outstanding effects for the Commission Delegated Regulation (EU) No 134/2014. (See end of Document for details)

- (32) ‘super-charger’ means an intake air compressor used for forced induction of a combustion engine, thereby increasing propulsion unit performance;
- (33) ‘fuel cell’ means a converter of chemical energy from hydrogen into electric energy for propulsion of the vehicle;
- (34) ‘crankcase’ means the spaces in or external to an engine which are connected to the oil sump by internal or external ducts through which gases and vapour can escape;
- (35) ‘permeability test’ means testing of the losses through the walls of the non-metallic fuel storage and preconditioning the non-metallic fuel storage material prior to fuel storage testing in accordance with Number C8 of Annex II to Regulation (EU) No 168/2013;
- (36) ‘permeation’ means the losses through the walls of the fuel storage and delivery systems, which is generally tested by determination of the weight losses;
- (37) ‘evaporation’ means the breathing losses from the fuel storage, fuel delivery system or other sources through which hydrocarbons breathe into the atmosphere;
- (38) ‘mileage accumulation’ means a representative test vehicle or a fleet of representative test vehicles driving a predefined distance as set out in points (a) or (b) of Article 23(3) to Regulation (EU) No 168/2013 in accordance with the test requirements of Annex VI to this Regulation;
- (39) ‘electric powertrain’ means a system consisting of one or more electric energy storage devices such as batteries, electromechanical flywheels, super capacitors or other, one or more electric power conditioning devices and one or more electric machines that convert stored electric energy to mechanical energy delivered at the wheels for propulsion of the vehicle;
- (40) ‘electric range’, means the distance that vehicles powered by an electric powertrain only or by a hybrid electric powertrain with off-vehicle charging can drive electrically on one fully charged battery or other electric energy storage device as measured in accordance with the procedure set out in Appendix 3.3. to Annex VII;
- (41) ‘OVC range’ means the total distance covered during complete combined cycles run until the energy imparted by external charging of the battery (or other electric energy storage device) is depleted, as measured in accordance with the procedure described in Appendix 3.3. to Annex VII;
- (42) ‘maximum thirty minutes speed’ of a vehicle means the maximum achievable vehicle speed measured during 30 minutes as a result of the 30 minute power set out in UNECE regulation No 85;
- (43) ‘propulsion unit performance type-approval’ of a vehicle means the approval of a vehicle type, variant or version with regard to the performance of the propulsion units as regards the following conditions:
 - (a) the maximum design vehicle speed(s);
 - (b) the maximum continuous rated torque or maximum net torque;
 - (c) the maximum continuous rated power or the maximum net power;
 - (d) the maximum total torque and power in the case of a hybrid application.

Status: Point in time view as at 16/12/2013.

Changes to legislation: There are currently no known outstanding effects for the Commission Delegated Regulation (EU) No 134/2014. (See end of Document for details)

- (44) ‘propulsion type’ means the propulsion units whose characteristics do not differ in any fundamental respect as regards maximum design vehicle speed, maximum net power, maximum continuous rated power and maximum torque;
- (45) ‘net power’ means the power available on the test bench at the end of the crankshaft or equivalent component of the propulsion unit at the rotation speeds measured by the manufacturer at type-approval, together with the accessories listed in Tables Ap2.1-1 or Ap2.2-1 of Appendix 2 of Annex X, and taking into account the efficiency of the gearbox where the net power can only be measured with the gearbox fitted to the propulsion;
- (46) ‘maximum net power’ means the maximum net power output from propulsion units that include one or more combustion engines, under full engine load operation;
- (47) ‘maximum torque’ means the maximum torque value measured under full engine load operation;
- (48) ‘accessories’ means all apparatus and devices listed in Table Ap2.1-1 or Ap2.2-1 of Annex X.

CHAPTER II

OBLIGATIONS OF THE MANUFACTURER REGARDING THE ENVIRONMENTAL PERFORMANCE OF VEHICLES

Article 3

Fitting and demonstration requirements related to the environmental performance of L-category vehicles

1 The manufacturer shall equip L-category vehicles with systems, components and separate technical units affecting the environmental performance of a vehicle that are designed, constructed and assembled so as to enable the vehicle in normal use and maintained according to the prescriptions of the manufacturer to comply with the detailed technical requirements and testing procedures of this Regulation.

2 The manufacturer shall demonstrate by means of physical demonstration testing to the approval authority that the L-category vehicles made available on the market, registered or entering into service in the Union comply with the detailed technical requirements and test procedures concerning the environmental performance of these vehicles laid down in Articles 5 to 15.

3 Where the manufacturer modifies the characteristics of the emission abatement system or performance of any of the emission-relevant components after the approved vehicle type with regard to environmental performance is placed on the market, the manufacturer shall report this to the approval authority without delay. The manufacturer shall provide evidence to the approval authority that the changed emission abatement system or component characteristics do not result in a worse environmental performance than that demonstrated at type-approval.

4 The manufacturer shall ensure that spare parts and equipment that are made available on the market or are entering into service in the Union comply with the detailed technical requirements and test procedures with respect to the environmental performance of the vehicles referred to in this Regulation. An approved L-category vehicle equipped with such a spare part or equipment shall meet the same test requirements and performance limit values as a

Status: Point in time view as at 16/12/2013.

Changes to legislation: There are currently no known outstanding effects for the Commission Delegated Regulation (EU) No 134/2014. (See end of Document for details)

vehicle equipped with an original part or equipment satisfying endurance requirements up to and including those set out in Article 22(2), Article 23 and Article 24 of Regulation (EU) No 168/2013.

5 The manufacturer shall ensure that type-approval procedures for verifying conformity of production are followed as regards the detailed environmental and propulsion unit performance requirements laid down in Article 33 of Regulation (EU) No 168/2013 and its Number C3 of Annex II.

6 The manufacturer shall submit to the approval authority a description of the measures taken to prevent tampering with the powertrain management system including the computers controlling the environmental and propulsion unit performance in accordance with Number C1 of Annex II to Regulation (EU) No 168/2013.

7 For hybrid applications or applications equipped with a stop-start system, the manufacturer shall install on the vehicle a 'service mode' that makes it possible, subject to environmental and propulsion unit performance testing or inspection, for the vehicle to continuously run the fuel-consuming engine. Where that inspection or test execution requires a special procedure, this shall be detailed in the service manual (or equivalent media). That special procedure shall not require the use of special equipment other than that provided with the vehicle.

Article 4

Application of UNECE regulations

1 The UNECE regulations and amendments thereto set out in Annex I to this Regulation shall apply to environmental and propulsion unit performance type approval.

2 Vehicles with a maximum design vehicle speed ≤ 25 km/h shall meet all the relevant requirements of UNECE regulations applying to vehicles with a maximum vehicle design speed of > 25 km/h.

3 References to vehicle categories L₁, L₂, L₃, L₄, L₅, L₆ and L₇ in the UNECE regulations shall be understood as references to vehicle categories L1e, L2e, L3e, L4e, L5e, L6e and L7e respectively under this Regulation, including any sub-categories.

Article 5

Technical specifications, requirements and test procedures with respect to the environmental performance of L-category vehicles

1 The environmental and propulsion unit performance test procedures shall be performed in accordance with the test requirements laid down in this Regulation.

2 The test procedures shall be carried out or witnessed by the approval authority or, if authorised by the approval authority, by the technical service. The manufacturer shall select a representative parent vehicle to demonstrate compliance of the environmental performance of the L-category vehicles to the satisfaction of the approval authority complying with the requirements of Annex XI.

3 The measurement methods and test results shall be reported to the approval authority in the test report format pursuant to Article 32(1) of Regulation (EU) No 168/2013.

Status: Point in time view as at 16/12/2013.

Changes to legislation: There are currently no known outstanding effects for the Commission Delegated Regulation (EU) No 134/2014. (See end of Document for details)

4 The environmental performance type-approval regarding test types I, II, III, IV, V, VII and VIII shall extend to different vehicle variants, versions and propulsion types and families, provided that the vehicle version, propulsion or pollution-control system parameters specified in Annex XI are identical or remain within the prescribed and declared tolerances in that Annex.

5 Hybrid applications or applications equipped with a stop-start system shall be tested with the fuel-consuming engine running where specified in the test procedure.

Article 6

Test type I requirements: tailpipe emissions after cold start

The test procedures and requirements applying to test type I on tailpipe emissions after cold start referred to in Part A of Annex V to Regulation (EU) No 168/2013, shall be conducted and verified in accordance with Annex II to this Regulation.

Article 7

Test type II requirements: tailpipe emissions at (increased) idle and at free acceleration

The test procedures and requirements applying to test type II on tailpipe emissions at (increased) idle and at free acceleration referred to in Part A of Annex V to Regulation (EU) No 168/2013, shall be conducted and verified in accordance with Annex III to this Regulation.

Article 8

Test type III requirements: emissions of crankcase gases

The test procedures and requirements applying to test type III on emissions of crankcase gases referred to in Part A of Annex V to Regulation (EU) No 168/2013, shall be conducted and verified in accordance with Annex IV to this Regulation.

Article 9

Test type IV requirements: evaporative emissions

The test procedures and requirements applying to test type IV on evaporative emissions referred to in Part A of Annex V to Regulation (EU) No 168/2013, shall be conducted and verified in accordance with Annex V to this Regulation.

Article 10

Test type V requirements: durability of pollution-control devices

The type V durability of pollution-control devices test procedures and requirements referred to in Part A of Annex V to Regulation (EU) No 168/2013, shall be conducted and verified in accordance with Annex VI to this Regulation.

Status: Point in time view as at 16/12/2013.

Changes to legislation: There are currently no known outstanding effects for the Commission Delegated Regulation (EU) No 134/2014. (See end of Document for details)

Article 11

Test type VII requirements: CO₂ emissions, fuel consumption, electric energy consumption or electric range

The test procedures and requirements applying to test type VII on energy efficiency with respect to CO₂ emissions, fuel consumption, electric energy consumption or electric range referred to in Part A of Annex V to Regulation (EU) No 168/2013, shall be conducted and verified in accordance with Annex VII to this Regulation.

Article 12

Test type VIII requirements: OBD environmental tests

The test procedures and requirements applying to test type VIII on the environmental part of on-board diagnostics (OBD) referred to in Part A of Annex V to Regulation (EU) No 168/2013, shall be conducted and verified in accordance with Annex VIII to this Regulation.

Article 13

Test type IX requirements: sound level

The type test procedures and requirements applying to test type IX on sound level referred to in Part A of Annex V to Regulation (EU) No 168/2013, shall be conducted and verified in accordance with Annex IX to this Regulation.

CHAPTER III

OBLIGATIONS OF MANUFACTURERS REGARDING THE PROPULSION PERFORMANCE OF VEHICLES

Article 14

General obligations

1 Before making an L-category vehicle available on the market, the manufacturer shall demonstrate the propulsion unit performance of the L-category vehicle type to the approval authority in accordance with the requirements laid down in this Regulation.

2 When making an L-category vehicle available on the market or registering it or before its entry into service, the manufacturer shall ensure that the propulsion unit performance of the L-category vehicle type does not exceed that reported to the approval authority in the information folder provided for in Article 27 of Regulation (EU) No 168/2013.

3 The propulsion unit performance of a vehicle equipped with a replacement system, component or separate technical unit shall not exceed that of a vehicle equipped with the original systems, components or separate technical units.

Status: Point in time view as at 16/12/2013.

Changes to legislation: There are currently no known outstanding effects for the Commission Delegated Regulation (EU) No 134/2014. (See end of Document for details)

Article 15

Propulsion performance requirements

The test procedures and requirements on propulsion unit performance referred to in Number A2 of Annex II to Regulation (EU) No 168/2013, shall be conducted and verified in accordance with Annex X to this Regulation.

CHAPTER IV

OBLIGATIONS OF THE MEMBER STATES

Article 16

Type-approval of L-category vehicles, their systems, components or separate technical units

1 Where a manufacturer so requests, the national authorities shall not, on grounds relating to the environmental performance of vehicle, refuse to grant an environmental and propulsion unit performance type-approval or national approval for a new type of vehicle, or prohibit the making available on the market, registration, or entry into service of a vehicle, system, component or separate technical unit, where the vehicle concerned complies with Regulation (EU) No 168/2013 and the detailed test requirements laid down in this Regulation.

2 With effect from the dates laid down in Annex IV to Regulation (EU) No 168/2013, national authorities shall, in the case of new vehicles that do not comply with the Euro 4 environmental step set out in Parts A1, B1, C1 and D of Annex VI and Annex VII to Regulation (EU) No 168/2013 or the Euro 5 environmental step set out in Parts A2, B2, C2 and D of Annex VI and Annex VII to Regulation (EU) No 168/2013 consider certificates of conformity containing previous environmental limit values to be no longer valid for the purposes of Article 43(1) of Regulation (EU) No 168/2013 and shall, on grounds relating to emissions, fuel or energy consumption, or the applicable functional safety or vehicle construction requirements, prohibit the making available on the market, registration or entry into service of such vehicles.

3 When applying Article 77(5) of Regulation (EU) No 168/2013, national authorities shall classify the approved vehicle type in accordance with Annex I to that Regulation.

Article 17

Type-approval of replacement pollution-control devices

1 National authorities shall prohibit the making available on the market or installation on a vehicle of new replacement pollution-control devices intended to be fitted on vehicles approved under this Regulation where they are not of a type in respect of which an environmental and propulsion unit performance type-approval has been granted in compliance with Article 23(10) of Regulation (EU) No 168/2013 and with this Regulation.

2 National authorities may continue to grant extensions to EU type-approvals referred to in Article 35 of Regulation (EU) No 168/2013 for replacement pollution-control devices which are of a type in the scope of Directive 2002/24/EC under the terms which originally applied.

Status: Point in time view as at 16/12/2013.

Changes to legislation: There are currently no known outstanding effects for the Commission Delegated Regulation (EU) No 134/2014. (See end of Document for details)

National authorities shall prohibit the making available on the market or installation on a vehicle of such replacement pollution-control device type unless they are of a type in respect of which a relevant type-approval has been granted.

3 A replacement pollution-control device type intended to be fitted to a vehicle type-approved in compliance with this Regulation shall be tested in accordance with Appendix 10 to Annex II and with Annex VI.

4 Original equipment replacement pollution-control devices which are of a type covered by this Regulation and which are intended to be fitted to a vehicle which the relevant whole vehicle type-approval document refers to, do not need to comply with the test requirements of Appendix 10 to Annex II, provided they fulfil the requirements of point 4 of that Appendix.

CHAPTER V

FINAL PROVISIONS

Article 18

Amendment of Annex V to Regulation (EU) No 168/2013

Part A of Annex V to Regulation (EU) No 168/2013 is amended in accordance with Annex XII.

Article 19

Entry into force

1 This Regulation shall enter into force on the day following that of its publication in the *Official Journal of the European Union*.

2 It shall apply from 1 January 2016.

This Regulation shall be binding in its entirety and directly applicable in all Member States.

Done at Brussels, 16 December 2013.

For the Commission

The President

José Manuel BARROSO

Status: Point in time view as at 16/12/2013.

Changes to legislation: There are currently no known outstanding effects for the Commission Delegated Regulation (EU) No 134/2014. (See end of Document for details)

LIST OF ANNEXES

Annex Number	Annex title	Page
I	List of UNECE regulations which apply on a compulsory basis	11
II	Test type I requirements: tailpipe emissions after cold start	12
III	Test type II requirements: tailpipe emissions at (increased) idle and free acceleration	159
IV	Test type III requirements: emissions of crankcase gases	163
V	Test type IV requirements: evaporative emissions	167
VI	Test type V requirements: durability of pollution-control devices	188
VII	Test type VII requirements; CO ₂ emissions, fuel consumption, electric energy consumption and electric range	207
VIII	Test type VIII requirements: OBD environmental tests	240
IX	Test type IX requirements: sound level	245
X	Testing procedures and technical requirements as regards propulsion unit performance	288
XI	Vehicle propulsion family with regard to environmental performance demonstration testing	320
XII	Amendment of Part A of Annex V to Regulation (EU) No 168/2013	326

Status: Point in time view as at 16/12/2013.

Changes to legislation: There are currently no known outstanding effects for the Commission Delegated Regulation (EU) No 134/2014. (See end of Document for details)

ANNEX I

LIST OF UNECE REGULATIONS WHICH APPLY ON A COMPULSORY BASIS

UNECE regulation No	Subject	Series of amendments	OJ Reference	Applicability
41	Noise emissions of motorcycles	04	OJ L 317, 14.11.2012, p. 1	L3e, L4e

Explanatory note:

The fact that a system or component is included in this list does not make its installation mandatory. For certain components, however, mandatory installation requirements are laid down in other annexes to this Regulation.

Status: Point in time view as at 16/12/2013.

Changes to legislation: There are currently no known outstanding effects for the Commission Delegated Regulation (EU) No 134/2014. (See end of Document for details)

ANNEX II

Test type I requirements: tailpipe emissions after cold start

Appendix Number	Appendix title	Page
1	Symbols used in Annex II	74
2	Reference fuels	78
3	Chassis dynamometer system	85
4	Exhaust dilution system	91
5	Classification of equivalent inertia mass and running resistance	103
6	Driving cycles for type I tests	106
7	Road tests of L-category vehicles equipped with one wheel on the driven axle or with twinned wheels for the determination of test bench settings	153
8	Road tests of L-category vehicles equipped with two or more wheels on the powered axle for the determination of test bench settings	160
9	Explanatory note on the gearshift procedure for a type I test	168
10	Type-approval tests of a replacement pollution-control device type for L-category vehicles as a separate technical unit	174
11	Type I test procedure for hybrid L-category vehicles	178
12	Type I test procedure for L-category vehicles fuelled with LPG, NG/biomethane, flex fuel H ₂ NG or hydrogen	189
13	Type I test procedure for L-category vehicles equipped with a periodically regenerating system	193

Status: Point in time view as at 16/12/2013.

Changes to legislation: There are currently no known outstanding effects for the Commission Delegated Regulation (EU) No 134/2014. (See end of Document for details)

1. Introduction

- 1.1. This Annex sets out the procedure for type I testing, as referred to in Part A of Annex V to Regulation (EU) No 168/2013.
- 1.2. This Annex provides a harmonised method for the determination of the levels of gaseous pollutant emissions and particulate matter, the emissions of carbon dioxide and is referred to in Annex VII to determine the fuel consumption, energy consumption and electric range of the L-category vehicle within the scope of Regulation (EU) No 168/2013 that are representative for real world vehicle operation.
 - 1.1.1. The ‘WMTC stage 1’ was introduced in EU type-approval legislation in 2006, which allowed manufacturers from then on to demonstrate the emission performance of the L3e motorcycle type by using the world harmonised motorcycle test cycle (WMTC) set out in UN GTR No 2 as alternative type I test to the use of the conventional European Driving Cycle (EDC) set out in Chapter 5 of Directive 97/24/EC.
 - 1.1.2. The ‘WMTC stage 2’ is equal to ‘WMTC stage 1’ with additional enhancements in the area of gear shift prescriptions and shall be used as compulsory type I test to approve Euro 4 compliant (sub-)categories L3e, L4e, L5e-A and L7e-A vehicles.
 - 1.1.3. The ‘revised WMTC’ or ‘WMTC stage 3’ is equal to ‘WMTC stage 2’ for L3e motorcycles, but contains also custom-tailored driving cycles for all other (sub-)category vehicles, used as type I test to approve Euro 5 compliant L-category vehicles.
- 1.2. The results may form the basis for limiting gaseous pollutants, carbon dioxide and for the fuel consumption, energy consumption and electric range indicated by the manufacturer within the environmental performance type-approval procedures.

2. General requirements

- 2.1. The components liable to affect the emission of gaseous pollutants, carbon dioxide emissions and fuel consumption shall be so designed, constructed and assembled as to enable the vehicle in normal use, despite the vibration to which it may be subjected, to comply with the provisions of this Annex.

Note 1: The symbols used in Annex II are summarised in Appendix 1.

- 2.2. Any hidden strategy that ‘optimises’ the powertrain of the vehicle running the relevant emission laboratory test cycle in an advantageous way, reducing tailpipe emissions and running significantly differently under real-world conditions, is considered a defeat strategy and is prohibited, unless the manufacturer has documented and declared it to the satisfaction of the approval authority.

3. Performance requirements

The applicable performance requirements for EU type-approval are referred to in Parts A, B and C of Annex VI to Regulation (EU) No 168/2013.

4. Test conditions

- 4.1. Test room and soak area
 - 4.1.1. Test room

Status: Point in time view as at 16/12/2013.

Changes to legislation: There are currently no known outstanding effects for the Commission Delegated Regulation (EU) No 134/2014. (See end of Document for details)

The test room with the chassis dynamometer and the gas sample collection device shall have a temperature of $298,2 \pm 5$ K (25 ± 5 °C). The room temperature shall be measured in the vicinity of the vehicle cooling blower (fan) before and after the type I test.

4.1.2. Soak area

The soak area shall have a temperature of $298,2 \pm 5$ K (25 ± 5 °C) and be such that the test vehicle to be preconditioned can be parked in accordance with point 5.2.4. of this Annex.

4.2. Test vehicle

4.2.1. General

All components of the test vehicle shall conform to those of the production series or, if the vehicle is different from the production series, a full description shall be given in the test report. In selecting the test vehicle, the manufacturer and the technical service shall agree to the satisfaction of the approval authority which tested parent vehicle is representative of the related vehicle propulsion family as laid down in Annex XI.

4.2.2. Run-in

The vehicle shall be presented in good mechanical condition, properly maintained and used. It shall have been run in and driven at least 1 000 km before the test. The engine, drive train and vehicle shall be properly run in, in accordance with the manufacturer's requirements.

4.2.3. Adjustments

The test vehicle shall be adjusted in accordance with the manufacturer's requirements, e.g. as regards the viscosity of the oils, or, if it differs from the production series, a full description shall be given in the test report. In case of a four by four drive, the axle to which the lowest torque is delivered may be deactivated in order to allow testing on a standard chassis dynamometer.

4.2.4. Test mass and load distribution

The test mass, including the masses of the rider and the instruments, shall be measured before the beginning of the tests. The load shall be distributed across the wheels in conformity with the manufacturer's instructions.

4.2.5. Tyres

The tyres shall be of a type specified as original equipment by the vehicle manufacturer. The tyre pressures shall be adjusted to the specifications of the manufacturer or to those where the speed of the vehicle during the road test and the vehicle speed obtained on the chassis dynamometer are equalised. The tyre pressure shall be indicated in the test report.

4.3. L-category vehicle sub-classification

Figure 1-1 provides a graphical overview of the L-category vehicle sub-classification in terms of engine capacity and maximum vehicle speed if subject to environmental test types I, VII and VIII, indicated by the (sub-)class numbers in the graph areas. The numerical values of the engine capacity and maximum vehicle speed shall not be rounded up or down.

Figure 1-1

L-category vehicle sub-classification for environmental testing, test types I, VII and VIII

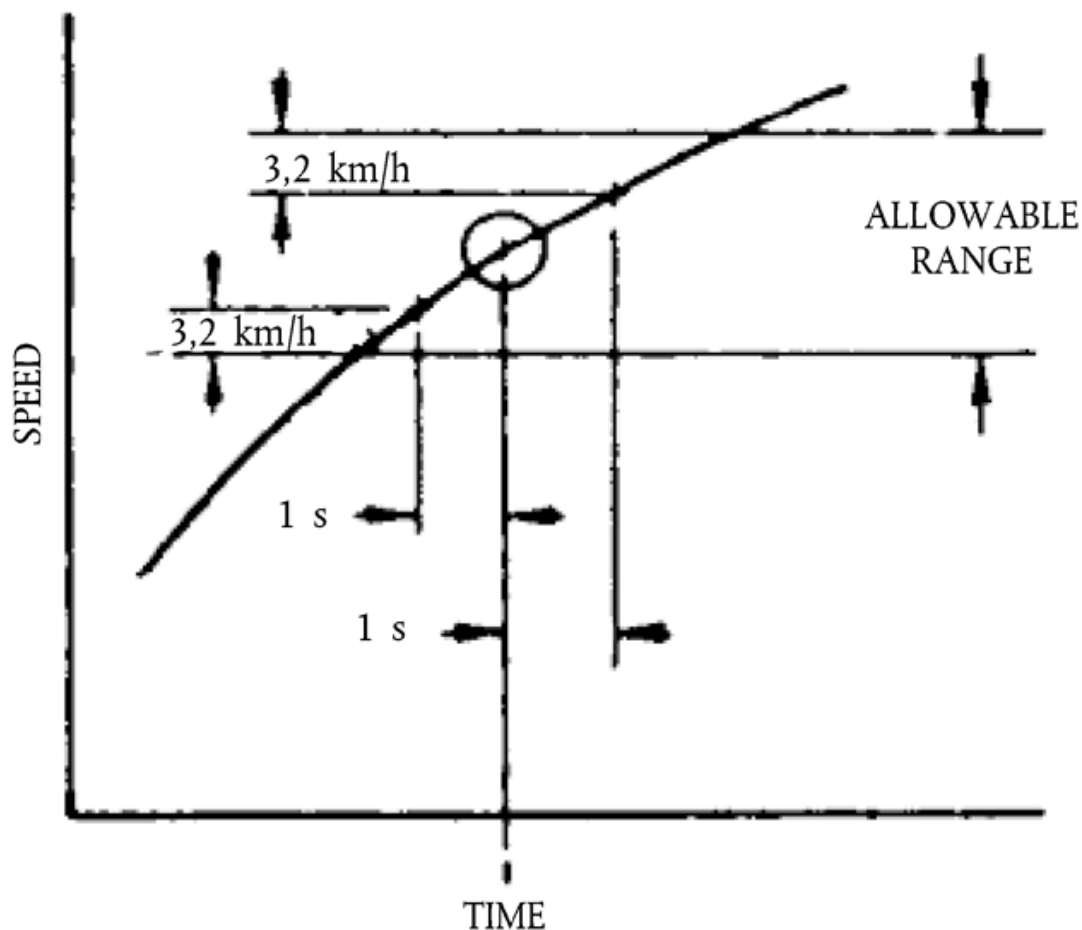

4.3.1. Class 1

L-category vehicles that fulfil the following specifications belong to class 1:

TABLE 1-1

sub-classification criteria for class 1 L-category vehicles

engine capacity < 150 cm ³ and v _{max} < 100 km/h	class 1
---	---------

4.3.2. Class 2

L-category vehicles that fulfil the following specifications belong to class 2 and shall be sub-classified in:

TABLE 1-2

sub-classification criteria for class 2 L-category vehicles

Status: Point in time view as at 16/12/2013.

Changes to legislation: There are currently no known outstanding effects for the Commission Delegated Regulation (EU) No 134/2014. (See end of Document for details)

Engine capacity < 150 cm ³ and 100 km/h ≤ v _{max} < 115 km/h or engine capacity ≥ 150 cm ³ and v _{max} < 115 km/h	sub-class 2-1
115 km/h ≤ v _{max} < 130 km/h	sub-class 2-2

4.3.3. Class 3

L-category vehicles that fulfil the following specifications belong to class 3 and shall be sub-classified in:

TABLE 1-3

sub-classification criteria for class 3 L-category vehicles

130 ≤ v _{max} < 140 km/h	subclass 3-1
v _{max} ≥ 140 km/h or engine capacity > 1 500 cm ³	subclass 3-2

4.3.4. WMTC, test cycle parts

The WMTC test cycle (vehicle speed patterns) for type I, VII and VIII environmental tests consist of up to three parts as set out in Appendix 6. Depending on the L-vehicle category subject to the WMTC laid down in point 4.5.4.1. and its classification in terms of engine displacement and maximum design vehicle speed in accordance with point 4.3, the following WMTC test cycle parts must be run:

TABLE 1-4

WMTC test cycle parts for class 1.2 and 3 L-category vehicles

L-category vehicle (sub-)class	Applicable parts of the WMTC as specified in Appendix 6
Class 1:	part 1, reduced vehicle speed in cold condition, followed by part 1, reduced vehicle speed in warm condition.
Class 2 subdivided in:	
Sub-class 2-1:	part 1, reduced vehicle speed in cold condition, followed by part 2, reduced vehicle speed in warm condition.
Sub-class 2-2:	part 1, in cold condition, followed by part 2, in warm condition.
Class 3 subdivided in:	
Sub-class 3-1:	part 1, in cold condition, followed by part 2, in warm condition, followed by part 3, reduced vehicle speed in warm condition.
Sub-class 3-2:	part 1, in cold condition, followed by part 2, in warm condition, followed by part 3, in warm condition.

4.4. Specification of the reference fuel

The appropriate reference fuels as specified in Appendix 2 shall be used for testing. For the purpose of the calculation referred to in point 1.4 of Appendix 1 of Annex VII, for liquid fuels, the density measured at 288,2 K (15 °C) shall be used.

4.5. Type I test

4.5.1. Driver

The test driver shall have a mass of 75 kg ± 5 kg.

4.5.2. Test bench specifications and settings

4.5.2.1. The dynamometer shall have a single roller for two-wheel L-category vehicles with a diameter of at least 400 mm. A chassis dynamometer equipped with dual rollers is permitted when testing tricycles with two front wheels or quadricycles.

4.5.2.2. The dynamometer shall be equipped with a roller revolution counter for measuring actual distance travelled.

4.5.2.3. Dynamometer flywheels or other means shall be used to simulate the inertia specified in point 5.2.2.

4.5.2.4. The dynamometer rollers shall be clean, dry and free from anything which might cause the tyre to slip.

4.5.2.5. Cooling fan specifications as follows:

4.5.2.5.1. Throughout the test, a variable-speed cooling blower (fan) shall be positioned in front of the vehicle so as to direct the cooling air onto it in a manner that simulates actual operating conditions. The blower speed shall be such that, within the operating range of 10 to 50 km/h, the linear velocity of the air at the blower outlet is within ±5 km/h of the corresponding roller speed. At the range of over 50 km/h, the linear velocity of the air shall be within ± 10 percent. At roller speeds of less than 10 km/h, air velocity may be zero.

4.5.2.5.2. The air velocity referred to in point 4.5.2.5.1. shall be determined as an averaged value of nine measuring points which are located at the centre of each rectangle dividing the whole of the blower outlet into nine areas (dividing both horizontal and vertical sides of the blower outlet into three equal parts). The value at each of the nine points shall be within 10 percent of the average of the nine values.

4.5.2.5.3. The blower outlet shall have a cross-section area of at least 0.4 m² and the bottom of the blower outlet shall be between 5 and 20 cm above floor level. The blower outlet shall be perpendicular to the longitudinal axis of the vehicle, between 30 and 45 cm in front of its front wheel. The device used to measure the linear velocity of the air shall be located at between 0 and 20 cm from the air outlet.

4.5.2.6. The detailed requirements regarding test bench specifications are listed in Appendix 3.

4.5.3. Exhaust gas measurement system

4.5.3.1. The gas-collection device shall be a closed-type device that can collect all exhaust gases at the vehicle exhaust outlets on condition that it satisfies the backpressure condition of ± 125 mm H₂O. An open system may be used if it is confirmed that all the exhaust gases are collected. The gas collection shall be such that there is no

Status: Point in time view as at 16/12/2013.

Changes to legislation: There are currently no known outstanding effects for the Commission Delegated Regulation (EU) No 134/2014. (See end of Document for details)

condensation which could appreciably modify the nature of exhaust gases at the test temperature. An example of a gas-collection device is illustrated in Figure 1-2:

Figure 1-2

Equipment for sampling the gases and measuring their volume

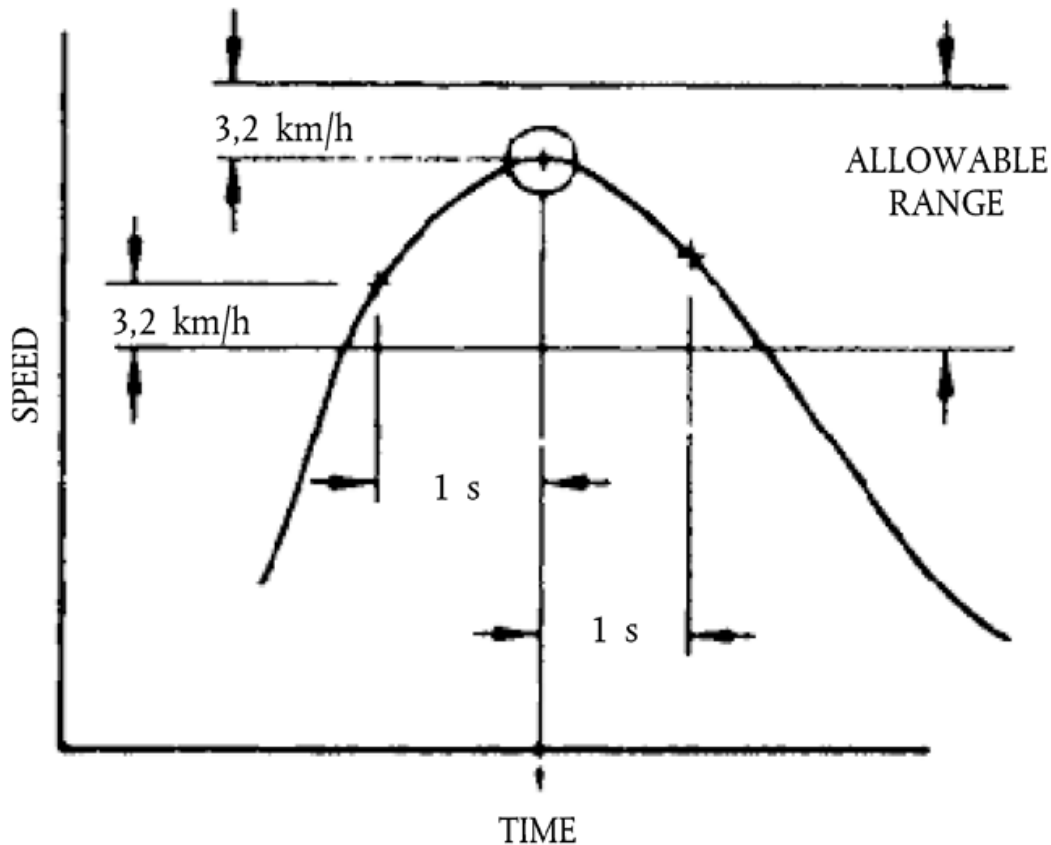

- 4.5.3.2. A connecting tube shall be placed between the device and the exhaust gas sampling system. This tube and the device shall be made of stainless steel, or of some other material which does not affect the composition of the gases collected and which withstands the temperature of these gases.
- 4.5.3.3. A heat exchanger capable of limiting the temperature variation of the diluted gases in the pump intake to ± 5 K shall be in operation throughout the test. This exchanger shall be equipped with a preheating system capable of bringing the exchanger to its operating temperature (with the tolerance of ± 5 K) before the test begins.
- 4.5.3.4. A positive displacement pump shall be used to draw in the diluted exhaust mixture. This pump shall be equipped with a motor with several strictly controlled uniform speeds. The pump capacity shall be large enough to ensure the intake of the exhaust gases. A device using a critical-flow venturi (CFV) may also be used.
- 4.5.3.5. A device (T) shall be used for the continuous recording of the temperature of the diluted exhaust mixture entering the pump.

Status: Point in time view as at 16/12/2013.

Changes to legislation: There are currently no known outstanding effects for the Commission Delegated Regulation (EU) No 134/2014. (See end of Document for details)

- 4.5.3.6. Two gauges shall be used, the first to ensure the pressure depression of the dilute exhaust mixture entering the pump relative to atmospheric pressure, and the second to measure the dynamic pressure variation of the positive displacement pump.
- 4.5.3.7. A probe shall be located near to, but outside, the gas-collecting device, to collect samples of the dilution air stream through a pump, a filter and a flow meter at constant flow rates throughout the test.
- 4.5.3.8. A sample probe pointed upstream into the dilute exhaust mixture flow, upstream of the positive displacement pump, shall be used to collect samples of the dilute exhaust mixture through a pump, a filter and a flow meter at constant flow rates throughout the test. The minimum sample flow rate in the sampling devices shown in Figure 1-2 and in point 4.5.3.7. shall be at least 150 litre/hour.
- 4.5.3.9. Three-way valves shall be used on the sampling system described in points 4.5.3.7. and 4.5.3.8. to direct the samples either to their respective bags or to the outside throughout the test.
- 4.5.3.10. Gas-tight collection bags
- 4.5.3.10.1. For dilution air and dilute exhaust mixture the collection bags shall be of sufficient capacity not to impede normal sample flow and shall not change the nature of the pollutants concerned.
- 4.5.3.10.2. The bags shall have an automatic self-locking device and shall be easily and tightly fastened either to the sampling system or the analysing system at the end of the test.
- 4.5.3.11. A revolution counter shall be used to count the revolutions of the positive displacement pump throughout the test.

Note 2: Attention shall be paid to the connecting method and the material or configuration of the connecting parts, because each section (e.g. the adapter and the coupler) of the sampling system can become very hot. If the measurement cannot be performed normally due to heat damage to the sampling system, an auxiliary cooling device may be used as long as the exhaust gases are not affected.

Note 3: With open type devices, there is a risk of incomplete gas collection and gas leakage into the test cell. There shall be no leakage throughout the sampling period.

Note 4: If a constant volume sampler (CVS) flow rate is used throughout the test cycle that includes low and high speeds all in one (i.e. part 1, 2 and 3 cycles), special attention shall be paid to the higher risk of water condensation in the high speed range.

- 4.5.3.12. Particulate mass emissions measurement equipment
- 4.5.3.12.1. Specification
- 4.5.3.12.1.1. System overview
- 4.5.3.12.1.1.1. The particulate sampling unit shall consist of a sampling probe located in the dilution tunnel, a particle transfer tube, a filter holder, a partial-flow pump, and flow rate regulators and measuring units.
- 4.5.3.12.1.1.2. It is recommended that a particle size pre-classifier (e.g. cyclone or impactor) be employed upstream of the filter holder. However, a sampling probe, used as an appropriate size-classification device such as that shown in Figure 1-6, is acceptable.

Status: Point in time view as at 16/12/2013.

Changes to legislation: There are currently no known outstanding effects for the Commission Delegated Regulation (EU) No 134/2014. (See end of Document for details)

4.5.3.12.1 General requirements

4.5.3.12.1 The sampling probe for the test gas flow for particulates shall be so arranged within the dilution tract that a representative sample gas flow can be taken from the homogeneous air/exhaust mixture.

4.5.3.12.1 The particulate sample flow rate shall be proportional to the total flow of diluted exhaust gas in the dilution tunnel to within a tolerance of ± 5 percent of the particulate sample flow rate.

4.5.3.12.1 The sampled dilute exhaust gas shall be maintained at a temperature below 325,2 K (52 °C) within 20 cm upstream or downstream of the particulate filter face, except in the case of a regeneration test, where the temperature shall be below 465,2 K (192 °C).

4.5.3.12.1 The particulate sample shall be collected on a single filter mounted in a holder in the sampled diluted exhaust gas flow

4.5.3.12.1 All parts of the dilution system and the sampling system from the exhaust pipe up to the filter holder which are in contact with raw and diluted exhaust gas shall be designed to minimise deposition or alteration of the particulates. All parts shall be made of electrically conductive materials that do not react with exhaust gas components, and shall be electrically grounded to prevent electrostatic effects.

4.5.3.12.1 If it is not possible to compensate for variations in the flow rate, provision shall be made for a heat exchanger and a temperature control device as specified in Appendix 4 so as to ensure that the flow rate in the system is constant and the sampling rate accordingly proportional.

4.5.3.12.2 Specific requirements

4.5.3.12.2 Particulate matter (PM) sampling probe

4.5.3.12.2 The sample probe shall deliver the particle-size classification performance described in point 4.5.3.12.1.3.1.4. It is recommended that this performance be achieved by the use of a sharp-edged, open-ended probe facing directly in the direction of flow, plus a pre-classifier (cyclone impactor, etc.). An appropriate sampling probe, such as that indicated in Figure 1-1, may alternatively be used provided it achieves the pre-classification performance described in point 4.5.3.12.1.3.1.4.

4.5.3.12.2 The sample probe shall be installed near the tunnel centreline between ten and 20 tunnel diameters downstream of the exhaust gas inlet to the tunnel and have an internal diameter of at least 12 mm.

If more than one simultaneous sample is drawn from a single sample probe, the flow drawn from that probe shall be split into identical sub-flows to avoid sampling artefacts.

If multiple probes are used, each probe shall be sharp-edged, open-ended and facing directly into the direction of flow. Probes shall be equally spaced at least 5 cm apart around the central longitudinal axis of the dilution tunnel.

4.5.3.12.2 The distance from the sampling tip to the filter mount shall be at least five probe diameters, but shall not exceed 1 020 mm.

4.5.3.12.2 The pre-classifier (e.g. cyclone, impactor, etc.) shall be located upstream of the filter holder assembly. The pre-classifier 50 percent cut point particle diameter shall be between 2.5 μm and 10 μm at the volumetric flow rate selected for sampling particulate mass emissions. The pre-classifier shall allow at least 99 percent of the

Status: Point in time view as at 16/12/2013.

Changes to legislation: There are currently no known outstanding effects for the Commission Delegated Regulation (EU) No 134/2014. (See end of Document for details)

mass concentration of 1 µm particles entering the pre-classifier to pass through the exit of the pre-classifier at the volumetric flow rate selected for sampling particulate mass emissions. However, a sampling probe, used as an appropriate size-classification device, such as that shown in Figure 1-6, is acceptable as an alternative to a separate pre-classifier.

4.5.3.12.1. Sample pump and flow meter

4.5.3.12.1.1. The sample gas flow measurement unit shall consist of pumps, gas flow regulators and flow measuring units.

4.5.3.12.1.2. The temperature of the gas flow in the flow meter may not fluctuate by more than ± 3 K, except during regeneration tests on vehicles equipped with periodically regenerating after-treatment devices. In addition, the sample mass flow rate shall remain proportional to the total flow of diluted exhaust gas to within a tolerance of ± 5 percent of the particulate sample mass flow rate. Should the volume of flow change unacceptably as a result of excessive filter loading, the test shall be stopped. When the test is repeated, the rate of flow shall be decreased.

4.5.3.12.2. Filter and filter holder

4.5.3.12.2.1. A valve shall be located downstream of the filter in the direction of flow. The valve shall be responsive enough to open and close within one second of the start and end of the test.

4.5.3.12.2.2. It is recommended that the mass collected on the 47 mm diameter filter (P_e) is ≥ 20 µg and that the filter loading is maximised in line with the requirements of points 4.5.3.12.1.2.3. and 4.5.3.12.1.3.3.

4.5.3.12.2.3. For a given test, the gas filter face velocity shall be set to a single value within the range 20 cm/s to 80 cm/s, unless the dilution system is being operated with sampling flow proportional to CVS flow rate.

4.5.3.12.2.4. Fluorocarbon coated glass fibre filters or fluorocarbon membrane filters are required. All filter types shall have a 0,3 µm DOP (di-octylphthalate) or PAO (poly-alpha-olefin) CS 68649-12-7 or CS 68037-01-4 collection efficiency of at least 99 percent at a gas filter face velocity of 5,33 cm/s.

4.5.3.12.2.5. The filter holder assembly shall be of a design that provides an even flow distribution across the filter stain area. The filter stain area shall be at least 1 075 mm².

4.5.3.12.3. Filter weighing chamber and balance

4.5.3.12.3.1. The microgram balance used to determine the weight of a filter shall have a precision (standard deviation) of 2 µg and resolution of 1 µg or better.

It is recommended that the microbalance be checked at the start of each weighing session by weighing one reference weight of 50 mg. This weight shall be weighed three times and the average result recorded. The weighing session and balance are considered valid if the average result of the weighing is within ± 5 µg of the result from the previous weighing session.

The weighing chamber (or room) shall meet the following conditions during all filter conditioning and weighing operations:

- Temperature maintained at $295,2 \pm 3$ K (22 ± 3 °C);
- Relative humidity maintained at 45 ± 8 percent;
- Dew point maintained at $282,7 \pm 3$ K ($9,5 \pm 3$ °C).

Status: Point in time view as at 16/12/2013.

Changes to legislation: There are currently no known outstanding effects for the Commission Delegated Regulation (EU) No 134/2014. (See end of Document for details)

It is recommended that temperature and humidity conditions be recorded along with sample and reference filter weights.

4.5.3.12. Buoyancy correction

All filter weights shall be corrected for filter buoyancy in air.

The buoyancy correction depends on the density of the sample filter medium, the density of air, and the density of the calibration weight used to calibrate the balance. The density of the air is dependent on the pressure, temperature and humidity.

It is recommended that the temperature and dew point of the weighing environment be controlled to $295,2 \text{ K} \pm 1 \text{ K}$ ($22 \text{ °C} \pm 1 \text{ °C}$) and $282,7 \pm 1 \text{ K}$ ($9,5 \pm 1 \text{ °C}$) respectively. However, the minimum requirements stated in point 4.5.3.12.1.3.4.1. will also result in an acceptable correction for buoyancy effects. The correction for buoyancy shall be applied as follows:

Equation 2-1:

$$m_{\text{corr}} = m_{\text{uncorr}} \times \left(\frac{1 - (\rho_{\text{air}} / \rho_{\text{weight}})}{1 - (\rho_{\text{air}} / \rho_{\text{media}})} \right)$$

where:

m_{corr}	=	PM mass corrected for buoyancy
m_{uncorr}	=	PM mass uncorrected for buoyancy
ρ_{air}	=	density of air in balance environment
ρ_{weight}	=	density of calibration weight used to span balance
ρ_{media}	=	density of PM sample medium (filter) with filter medium Teflon coated glass fibre (e.g. TX40): $\rho_{\text{media}} = 2,300 \text{ kg/m}^3$

ρ_{air} can be calculated as follows:

Equation 2-2:

$$\rho_{\text{air}} = \frac{P_{\text{abs}} \times M_{\text{mix}}}{R \times T_{\text{amb}}}$$

where:

P_{abs}	=	absolute pressure in balance environment
M_{mix}	=	molar mass of air in balance environment ($28,836 \text{ g mol}^{-1}$)
R	=	molar gas constant ($8,314 \text{ J mol}^{-1} \text{ K}^{-1}$)
T_{amb}	=	absolute ambient temperature of balance environment

The chamber (or room) environment shall be free of any ambient contaminants (such as dust) that would settle on the particulate filters during their stabilisation.

Limited deviations from weighing room temperature and humidity specifications shall be allowed provided their total duration does not exceed 30 minutes in any one filter conditioning period. The weighing room shall meet the required specifications prior to personal entrance into the weighing room. No deviations from the specified conditions are permitted during the weighing operation.

4.5.3.12. The effects of static electricity shall be nullified. This may be achieved by grounding the balance through placement on an antistatic mat and neutralisation of the particulate filters prior to weighing using a Polonium neutraliser or a device of similar effect. Alternatively, nullification of static effects may be achieved through equalisation of the static charge.

Status: Point in time view as at 16/12/2013.

Changes to legislation: There are currently no known outstanding effects for the Commission Delegated Regulation (EU) No 134/2014. (See end of Document for details)

4.5.3.12.1314. filter shall be removed from the chamber no earlier than an hour before the test begins.

4.5.3.12.14. Recommended system description

Figure 1-3 is a schematic drawing of the recommended particulate sampling system. Since various configurations can produce equivalent results, exact conformity with this figure is not required. Additional components such as instruments, valves, solenoids, pumps and switches may be used to provide additional information and coordinate the functions of component systems. Further components that are not needed to maintain accuracy with other system configurations may be excluded if their exclusion is based on good engineering judgment.

Figure 1-3

Status: Point in time view as at 16/12/2013.

Changes to legislation: There are currently no known outstanding effects for the Commission Delegated Regulation (EU) No 134/2014. (See end of Document for details)

Particulate sampling system

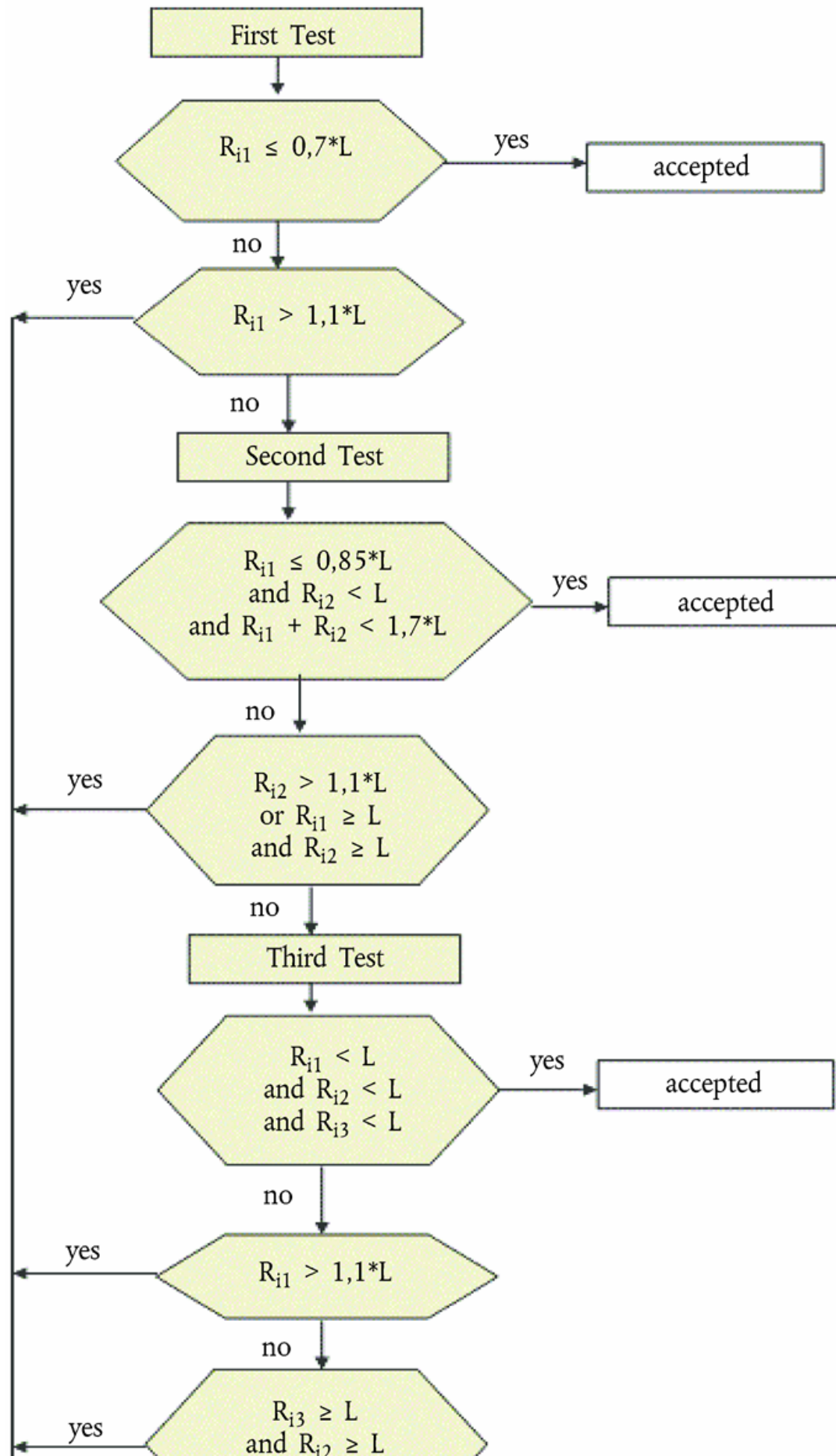

Status: Point in time view as at 16/12/2013.

Changes to legislation: There are currently no known outstanding effects for the Commission Delegated Regulation (EU) No 134/2014. (See end of Document for details)

A sample of the diluted exhaust gas is taken from the full flow dilution tunnel (DT) through the particulate sampling probe (PSP) and the particulate transfer tube (PTT) by means of the pump (P). The sample is passed through the particle size pre-classifier (PCF) and the filter holders (FH) that contain the particulate sampling filters. The flow rate for sampling is set by the flow controller (FC).

4.5.4. Driving schedules

4.5.4.1. Test cycles

Test cycles (vehicle speed patterns) for the type I test consist of up to three parts, as laid down in Appendix 6. Depending on the vehicle (sub-)category, the following test cycle parts must be run:

TABLE I-5

Applicable test type I cycle for Euro 4 compliant vehicles

Vehicle category	Vehicle category name	Test cycle Euro 4
L1e-A	Powered cycle	ECE R47
L1e-B	Two-wheel moped	
L2e	Three-wheel moped	
L6e-A	Light on-road quad	
L6e-B	Light quadri-mobile	
L3e	Two-wheel motorcycle with and without side-car	WMTC, stage 2
L4e		
L5e-A	Tricycle	
L7e-A	Heavy on-road quad	
L5e-B	Commercial tricycle	
L7e-B	Heavy all terrain quad	
L7e-C	Heavy quadri-mobile	

TABLE I-6

Applicable test type I cycle for Euro 5 compliant vehicles

Vehicle category	Vehicle category name	Test cycle Euro 5
L1e-A	Powered cycle	Revised WMTC
L1e-B	Two-wheel moped	
L2e	Three-wheel moped	
L6e-A	Light on-road quad	
L6e-B	Light quadri-mobile	
L3e	Two-wheel motorcycle with and without side-car	
L4e		
L5e-A	Tricycle	

Status: Point in time view as at 16/12/2013.

Changes to legislation: There are currently no known outstanding effects for the Commission Delegated Regulation (EU) No 134/2014. (See end of Document for details)

L7e-A	Heavy on-road quad
L5e-B	Commercial tricycle
L7e-B	Heavy all terrain quad
L7e-C	Heavy quadri-mobile

4.5.4.2. Vehicle speed tolerances

4.5.4.2.1. The vehicle speed tolerance at any given time on the test cycles prescribed in point 4.5.4.1. is defined by upper and lower limits. The upper limit is 3,2 km/h higher than the highest point on the trace within one second of the given time. The lower limit is 3,2 km/h lower than the lowest point on the trace within one second of the given time. Vehicle speed variations greater than the tolerances (such as may occur during gear changes) are acceptable provided they occur for less than two seconds on any occasion. Vehicle speeds lower than those prescribed are acceptable provided the vehicle is operated at maximum available power during such occurrences. Figure 1-4 shows the range of acceptable vehicle speed tolerances for typical points.

Figure 1-4

Drivers trace, allowable range

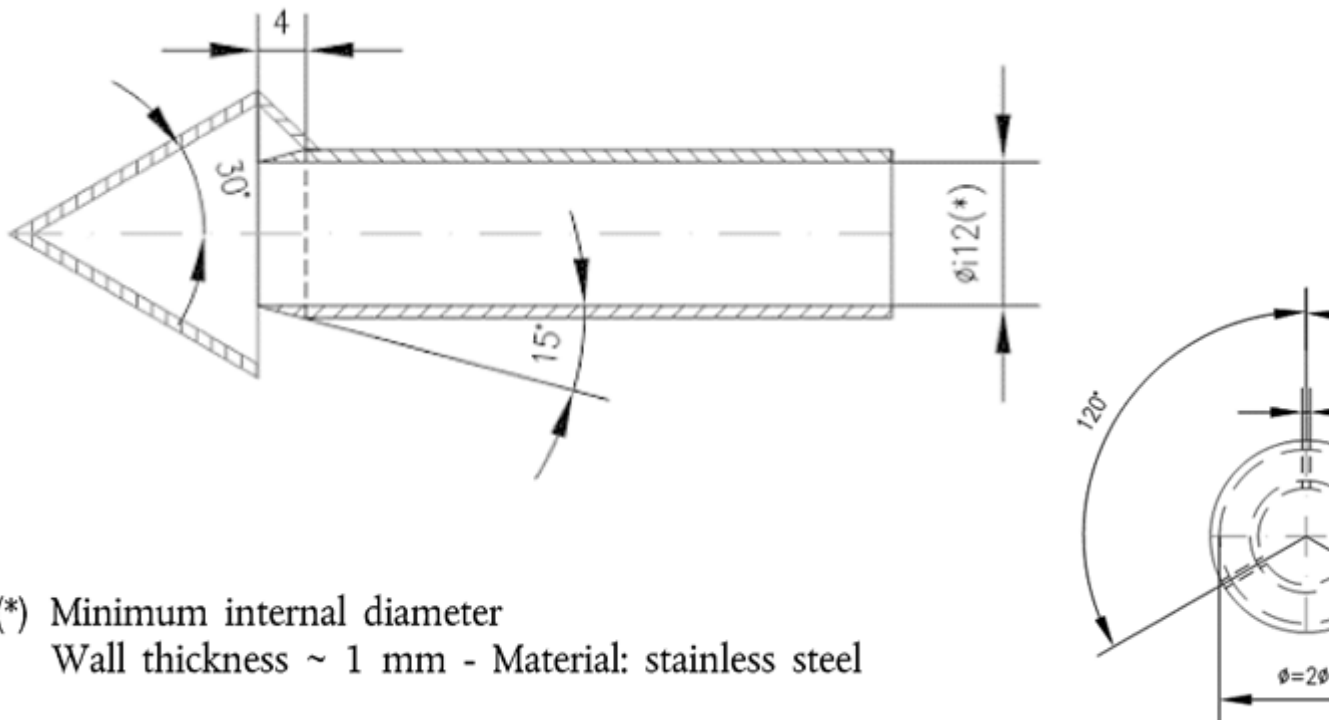

(*) Minimum internal diameter

Wall thickness ~ 1 mm - Material: stainless steel

4.5.4.2.2. If the acceleration capability of the vehicle is not sufficient to carry out the acceleration phases or if the maximum design speed of the vehicle is lower than the prescribed cruising speed within the prescribed limits of tolerances, the vehicle shall be driven with the throttle fully open until the set speed is reached or at the maximum design speed achievable with fully opened throttle during the time that the set speed exceeds the maximum design speed. In both cases, point 4.5.4.2.1. is not applicable. The test

Status: Point in time view as at 16/12/2013.

Changes to legislation: There are currently no known outstanding effects for the Commission Delegated Regulation (EU) No 134/2014. (See end of Document for details)

cycle shall be carried on normally when the set speed is again lower than the maximum design speed of the vehicle.

4.5.4.2.3. If the period of deceleration is shorter than that prescribed for the corresponding phase, the set speed shall be restored by a constant vehicle speed or idling period merging into succeeding constant speed or idling operation. In such cases, point 4.5.4.2.1. is not applicable.

4.5.4.2.4. Apart from these exceptions, the deviations of the roller speed from the set speed of the cycles shall meet the requirements described in point 4.5.4.2.1. If not, the test results shall not be used for further analysis and the run must be repeated.

4.5.5. Gearshift prescriptions for the WMTC prescribed in Appendix 6

4.5.5.1. Test vehicles with automatic transmission

4.5.5.1.1. Vehicles equipped with transfer cases, multiple sprockets, etc., shall be tested in the configuration recommended by the manufacturer for street or highway use.

4.5.5.1.2. All tests shall be conducted with automatic transmissions in 'Drive' (highest gear). Automatic clutch-torque converter transmissions may be shifted as manual transmissions at the request of the manufacturer.

4.5.5.1.3. Idle modes shall be run with automatic transmissions in 'Drive' and the wheels braked.

4.5.5.1.4. Automatic transmissions shall shift automatically through the normal sequence of gears. The torque converter clutch, if applicable, shall operate as under real-world conditions.

4.5.5.1.5. The deceleration modes shall be run in gear using brakes or throttle as necessary to maintain the desired speed.

4.5.5.2. Test vehicles with manual transmission

4.5.5.2.1 Mandatory requirements

4.5.5.2.1. Step 1 — Calculation of shift speeds

Upshift speeds ($v_{1 \rightarrow 2}$ and $v_{i \rightarrow i+1}$) in km/h during acceleration phases shall be calculated using the following formulae:

Equation 2-3:

$$v_{1 \rightarrow 2} = \left[\left(0,5753 \times e^{\left(-1,9 \times \frac{P_n}{m_k + 75} \right)} - 0,1 \right) \times (s - n_{idle}) + n_{idle} \right] \times \frac{1}{n d v_1}$$

Equation 2-4:

$$v_{i \rightarrow i+1} = \left[\left(0,5753 \times e^{\left(-1,9 \times \frac{P_n}{m_k + 75} \right)} \right) \times (s - n_{idle}) + n_{idle} \right] \times \frac{1}{n d v_i}$$

, i = 2 to ng - 1

where:

'i' is the gear number (≥ 2)

'ng' is the total number of forward gears

' P_n ' is the rated power in kW

' m_k ' is the reference mass in kg

Status: Point in time view as at 16/12/2013.

Changes to legislation: There are currently no known outstanding effects for the Commission Delegated Regulation (EU) No 134/2014. (See end of Document for details)

‘ n_{idle} ’ is the idling speed in min^{-1}

‘ s ’ is the rated engine speed in min^{-1}

‘ ndv_i ’ is the ratio between engine speed in min^{-1} and vehicle speed in km/h in gear ‘ i ’

4.5.5.2.1. Downshift speeds ($v_{i \rightarrow i-1}$) in km/h during cruise or deceleration phases in gears 4 (4th gear) to ng shall be calculated using the following formula:

Equation 2-5:

$$v_{i \rightarrow i-1} = \left[\left(0,5753 \times e^{\left(-1,9 \times \frac{P_n}{m_k + 75} \right)} \right) \times (s - n_{idle}) + n_{idle} \right] \times \frac{1}{ndv_{i-2}}$$

, $i = 4$ to ng

where:

i is the gear number (≥ 4)

ng is the total number of forward gears

P_n is the rated power in kW

m_k is the reference mass in kg

n_{idle} is the idling speed in min^{-1}

s is the rated engine speed in min^{-1}

ndv_{i-2} is the ratio between engine speed in min^{-1} and vehicle speed in km/h in gear $i-2$

The downshift speed from gear 3 to gear 2 ($v_{3 \rightarrow 2}$) shall be calculated using the following equation:

Equation 2-6:

$$v_{3 \rightarrow 2} = \left[\left(0,5753 \times e^{\left(-1,9 \times \frac{P_n}{m_k + 75} \right)} - 0,1 \right) \times (s - n_{idle}) + n_{idle} \right] \times \frac{1}{ndv_1}$$

where:

P_n is the rated power in kW

m_k is the reference mass in kg

n_{idle} is the idling speed in min^{-1}

s is the rated engine speed in min^{-1}

ndv_1 is the ratio between engine speed in min^{-1} and vehicle speed in km/h in gear 1

The downshift speed from gear 2 to gear 1 ($v_{2 \rightarrow 1}$) shall be calculated using the following equation:

Equation 2-7:

$$v_{2 \rightarrow 1} = [0,03 \times (s - n_{idle}) + n_{idle}] \times \frac{1}{ndv_2}$$

where:

ndv_2 is the ratio between engine speed in min^{-1} and vehicle speed in km/h in gear 2

Since the cruise phases are defined by the phase indicator, slight speed increases could occur and it may be appropriate to apply an upshift. The upshift speeds ($v_{1 \rightarrow 2}$, $v_{2 \rightarrow 3}$ and $v_{i \rightarrow i+1}$) in km/h during cruise phases shall be calculated using the following equations:

Status: Point in time view as at 16/12/2013.

Changes to legislation: There are currently no known outstanding effects for the Commission Delegated Regulation (EU) No 134/2014. (See end of Document for details)

Equation 2-7:

$$v_{1 \rightarrow 2} = [0,03 \times (s - n_{idle}) + n_{idle}] \times \frac{1}{ndv_2}$$

Equation 2-8:

$$v_{2 \rightarrow 3} = \left[\left(0,5753 \times e^{\left(-1,9 \times \frac{r_h}{n_{g_i} + 75} \right)} - 0,1 \right) \times (s - n_{idle}) + n_{idle} \right] \times \frac{1}{ndv_1}$$

Equation 2-9:

$$v_{i \rightarrow i+1} = \left[\left(0,5753 \times e^{\left(-1,9 \times \frac{r_h}{n_{g_i} + 75} \right)} \right) \times (s - n_{idle}) + n_{idle} \right] \times \frac{1}{ndv_{i-1}}$$

, i = 3 to ng

4.5.5.2.1. Step 2 — Gear choice for each cycle sample

In order to avoid different interpretations of acceleration, deceleration, cruise and stop phases, corresponding indicators are added to the vehicle speed pattern as integral parts of the cycles (see tables in Appendix 6).

The appropriate gear for each sample shall then be calculated according to the vehicle speed ranges resulting from the shift speed equations of point 4.5.5.2.1.1. and the phase indicators for the cycle parts appropriate for the test vehicle, as follows:

Gear choice for stop phases:

For the last five seconds of a stop phase, the gear lever shall be set to gear 1 and the clutch shall be disengaged. For the previous part of a stop phase, the gear lever shall be set to neutral or the clutch shall be disengaged.

Gear choice for acceleration phases:

- gear 1, if $v \leq v_{1 \rightarrow 2}$
- gear 2, if $v_{1 \rightarrow 2} < v \leq v_{2 \rightarrow 3}$
- gear 3, if $v_{2 \rightarrow 3} < v \leq v_{3 \rightarrow 4}$
- gear 4, if $v_{3 \rightarrow 4} < v \leq v_{4 \rightarrow 5}$
- gear 5, if $v_{4 \rightarrow 5} < v \leq v_{5 \rightarrow 6}$
- gear 6, if $v > v_{5 \rightarrow 6}$

Gear choice for deceleration or cruise phases:

- gear 1, if $v < v_{2 \rightarrow 1}$
- gear 2, if $v < v_{3 \rightarrow 2}$
- gear 3, if $v_{3 \rightarrow 2} \leq v < v_{4 \rightarrow 3}$
- gear 4, if $v_{4 \rightarrow 3} \leq v < v_{5 \rightarrow 4}$
- gear 5, if $v_{5 \rightarrow 4} \leq v < v_{6 \rightarrow 5}$
- gear 6, if $v \geq v_{4 \rightarrow 5}$

The clutch shall be disengaged, if:

- (a) the vehicle speed drops below 10 km/h, or
- (b) the engine speed drops below

$$n_{idle} + 0,03 \times (s - n_{idle})$$
 ;
- (c) there is a risk of engine stalling during cold-start phase.

Status: Point in time view as at 16/12/2013.

Changes to legislation: There are currently no known outstanding effects for the Commission Delegated Regulation (EU) No 134/2014. (See end of Document for details)

4.5.5.2.3. Step 3 — Corrections according to additional requirements

4.5.5.2.3. The gear choice shall be modified according to the following requirements:

- (a) no gearshift at a transition from an acceleration phase to a deceleration phase. The gear that was used for the last second of the acceleration phase shall be kept for the following deceleration phase unless the speed drops below a downshift speed;
- (b) no upshifts or downshifts by more than one gear, except from gear 2 to neutral during decelerations down to stop;
- (c) upshifts or downshifts for up to four seconds are replaced by the gear before, if the gears before and after are identical, e.g. 2 3 3 3 2 shall be replaced by 2 2 2 2 2, and 4 3 3 3 3 4 shall be replaced by 4 4 4 4 4. In the cases of consecutive circumstances, the gear used longer takes over, e.g. 2 2 2 3 3 3 2 2 2 3 3 3 will be replaced by 2 2 2 2 2 2 2 2 2 3 3 3. If used for the same time, a series of succeeding gears shall take precedence over a series of preceding gears, e.g. 2 2 2 3 3 3 2 2 2 3 3 3 will be replaced by 2 2 2 2 2 2 2 2 2 3 3 3;
- (d) no downshift during an acceleration phase.

4.5.5.2.2. Optional provisions

The gear choice may be modified according to the following provisions:

The use of gears lower than those determined by the requirements described in point 4.5.5.2.1. is permitted in any cycle phase. Manufacturers' recommendations for gear use shall be followed if they do not result in gears higher than determined by the requirements of point 4.5.5.2.1.

4.5.5.2.3. Optional provisions

Note 5: The calculation programme to be found on the UN website at the following URL may be used as an aid for the gear selection:

<http://live.unece.org/trans/main/wp29/wp29wgs/wp29grpe/wmtc.html>

Explanations of the approach and the gearshift strategy and a calculation example are given in Appendix 9.

4.5.6. Dynamometer settings

A full description of the chassis dynamometer and instruments shall be provided in accordance with Appendix 6. Measurements shall be taken to the accuracies specified in point 4.5.7. The running resistance force for the chassis dynamometer settings can be derived either from on-road coast-down measurements or from a running resistance table, with reference to Appendix 5 or 7 for a vehicle equipped with one wheel on the powered axle and to Appendix 8 for a vehicle with two or more wheels on the powered axles.

4.5.6.1. Chassis dynamometer setting derived from on-road coast-down measurements

To use this alternative, on-road coast-down measurements shall be carried out as specified in Appendix 7 for a vehicle equipped with one wheel on the powered axle and Appendix 8 for a vehicle equipped with two or more wheels on the powered axles.

4.5.6.1.1. Requirements for the equipment

The instrumentation for the speed and time measurement shall have the accuracies specified in point 4.5.7.

Status: Point in time view as at 16/12/2013.

Changes to legislation: There are currently no known outstanding effects for the Commission Delegated Regulation (EU) No 134/2014. (See end of Document for details)

4.5.6.1.2. Inertia mass setting

4.5.6.1.2. The equivalent inertia mass m_i for the chassis dynamometer shall be the flywheel equivalent inertia mass, m_{fi} , closest to the sum of the mass in running order of the vehicle and the mass of the driver (75 kg). Alternatively, the equivalent inertia mass m_i can be derived from Appendix 5.

4.5.6.1.2. If the reference mass m_{ref} cannot be equalised to the flywheel equivalent inertia mass m_i , to make the target running resistance force F^* equal to the running resistance force F_E (which is to be set to the chassis dynamometer), the corrected coast-down time ΔT_E may be adjusted in accordance with the total mass ratio of the target coast-down time ΔT_{road} in the following sequence:

Equation 2-10:

$$\Delta T_{road} = \frac{1}{3,6} (m_a + m_{r1}) \frac{2\Delta v}{F^*}$$

Equation 2-11:

$$\Delta T_E = \frac{1}{3,6} (m_i + m_{r1}) \frac{2\Delta v}{F_E}$$

Equation 2-12:

$$F_E = F^*$$

Equation 2-13:

$$\Delta T_E = \Delta T_{road} \times \frac{m_i + m_{r1}}{m_a + m_{r1}}$$

with

$$0,95 < \frac{m_i + m_{r1}}{m_a + m_{r1}} < 1,05$$

where:

m_{r1} may be measured or calculated, in kilograms, as appropriate. As an alternative, m_{r1} may be estimated as f percent of m .

4.5.6.2. Running resistance force derived from a running resistance table

4.5.6.2.1. The chassis dynamometer may be set by the use of the running resistance table instead of the running resistance force obtained by the coast-down method. In this table method, the chassis dynamometer shall be set by the mass in running order regardless of particular L-category vehicle characteristics.

Note 6: Care shall be taken when applying this method to L-category vehicles with extraordinary characteristics.

4.5.6.2.2. The flywheel equivalent inertia mass m_{fi} shall be the equivalent inertia mass m_i specified in Appendix 5, 7 or 8 where applicable. The chassis dynamometer shall be set by the rolling resistance of the non-driven wheels (a) and the aero drag coefficient (b) specified in Appendix 5 or determined in accordance with the procedures set out in Appendix 7 or 8 respectively.

4.5.6.2.3 The running resistance force on the chassis dynamometer F_E shall be determined using the following equation:

Equation 2-14:

$$F_E = F_R = a + b \times v^2$$

Status: Point in time view as at 16/12/2013.

Changes to legislation: There are currently no known outstanding effects for the Commission Delegated Regulation (EU) No 134/2014. (See end of Document for details)

4.5.6.2.4. The target running resistance force F^* shall be equal to the running resistance force obtained from the running resistance table F_T , because the correction for the standard ambient conditions is not necessary.

4.5.7. Measurement accuracies

Measurements shall be taken using equipment that fulfils the accuracy requirements in Table 1-7:

TABLE 1-7

Required accuracy of measurements

Measurement items		At measured value	Resolution
(a)	Running resistance force, F	+ 2 percent	—
(b)	Vehicle speed (v_1 , v_2)	± 1 percent	0,2 km/h
(c)	Coast-down speed interval ($2\Delta v = v_1 - v_2$)	± 1 percent	0,1 km/h
(d)	Coast-down time (Δt)	$\pm 0,5$ percent	0,01 s
(e)	Total vehicle mass ($m_k + m_{rid}$)	$\pm 0,5$ percent	1,0 kg
(f)	Wind speed	± 10 percent	0,1 m/s
(g)	Wind direction	—	5 deg.
(h)	Temperatures	± 1 K	1 K
(i)	Barometric pressure	—	0,2 kPa
(j)	Distance	$\pm 0,1$ percent	1 m
(k)	Time	$\pm 0,1$ s	0,1 s

5. Test procedures

5.1. Description of the type I test

The test vehicle shall be subjected, according to its category, to test type I requirements as specified in this point 5.

- 5.1.1. Type I test (verifying the average emission of gaseous pollutants, CO₂ emissions and fuel consumption in a characteristic driving cycle)
 - 5.1.1.1. The test shall be carried out by the method described in point 5.2. The gases shall be collected and analysed by the prescribed methods.
 - 5.1.1.2. Number of tests
 - 5.1.1.2.1. The number of tests shall be determined as shown in figure 1-5. R₁₁ to R₁₃ describe the final measurement results for the first (No 1) test to the third (No 3) test and the gaseous pollutant, carbon dioxide emission, fuel / energy consumption or electric range as laid down in Annex VII. 'L_x' represents the limit values L₁ to L₅ as defined in Parts A, B and C of Annex VI to Regulation (EU) No 168/2013.
 - 5.1.1.2.2. In each test, the masses of the carbon monoxide, hydrocarbons, nitrogen oxides, carbon dioxide and the fuel consumed during the test shall be determined. The mass of particulate matter shall be determined only for those (sub-)categories referred to in Parts A and B of Annex VI to Regulation (EU) No 168/2013 (see explanatory notes 8 and 9 at the end of Annex VIII to that Regulation).

Figure 1-5

Flowchart for the number of type I tests

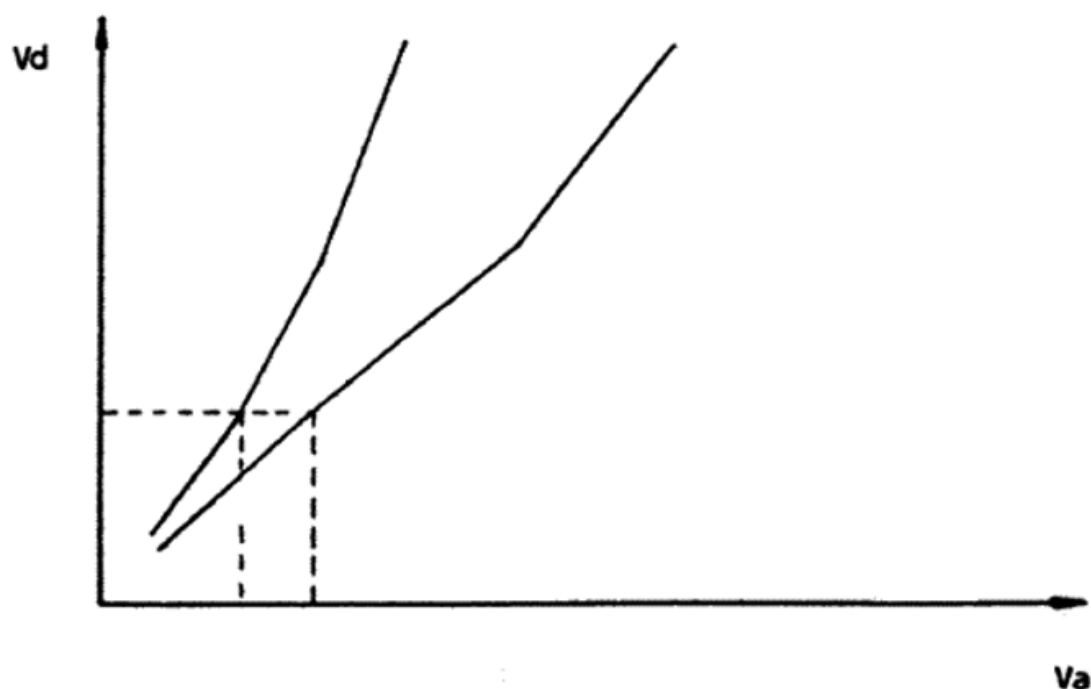

- 5.2. Type I tests
 - 5.2.1. Overview
 - 5.2.1.1. The type I test consists of prescribed sequences of dynamometer preparation, fuelling, parking, and operating conditions.
 - 5.2.1.2. The test is designed to determine hydrocarbon, carbon monoxide, oxides of nitrogen, carbon dioxide, particulate matter mass emissions if applicable and fuel / energy

Status: Point in time view as at 16/12/2013.

Changes to legislation: There are currently no known outstanding effects for the Commission Delegated Regulation (EU) No 134/2014. (See end of Document for details)

consumption as well as electric range while simulating real-world operation. The test consists of engine start-ups and L-category vehicle operation on a chassis dynamometer, through a specified driving cycle. A proportional part of the diluted exhaust emissions is collected continuously for subsequent analysis, using a constant volume (variable dilution) sampler (CVS).

5.2.1.3. Except in cases of component malfunction or failure, all emission-control systems installed on or incorporated in a tested L-category vehicle shall be functioning during all procedures.

5.2.1.4. Background concentrations are measured for all emission constituents for which emissions measurements are taken. For exhaust testing, this requires sampling and analysis of the dilution air.

5.2.1.5. Background particulate mass measurement

The particulate background level of the dilution air may be determined by passing filtered dilution air through the particulate filter. This shall be drawn from the same point as the particulate matter sample, if a particulate mass measurement is applicable according to Annex VI(A) to Regulation (EU) No 168/2013. One measurement may be performed prior to or after the test. Particulate mass measurements may be corrected by subtracting the background contribution from the dilution system. The permissible background contribution shall be ≤ 1 mg/km (or equivalent mass on the filter). If the background contribution exceeds this level, the default figure of 1 mg/km (or equivalent mass on the filter) shall be used. Where subtraction of the background contribution gives a negative result, the particulate mass result shall be considered to be zero.

5.2.2. Dynamometer settings and verification

5.2.2.1. Test vehicle preparation

5.2.2.1.1. The manufacturer shall provide additional fittings and adapters, as required to accommodate a fuel drain at the lowest point possible in the tanks as installed on the vehicle, and to provide for exhaust sample collection.

5.2.2.1.2. The tyre pressures shall be adjusted to the manufacturer's specifications to the satisfaction of the technical service or so that the speed of the vehicle during the road test and the vehicle speed obtained on the chassis dynamometer are equal.

5.2.2.1.3. The test vehicle shall be warmed up on the chassis dynamometer to the same condition as it was during the road test.

5.2.2.2. Dynamometer preparation, if settings are derived from on-road coast-down measurements

Before the test, the chassis dynamometer shall be appropriately warmed up to the stabilised frictional force F_f . The load on the chassis dynamometer F_E is, in view of its construction, composed of the total friction loss F_f , which is the sum of the chassis dynamometer rotating frictional resistance, the tyre rolling resistance, the frictional resistance of the rotating parts in the powertrain of the vehicle and the braking force of the power absorbing unit (pau) F_{pau} , as in the following equation:

Equation 2-15:

$$F_E = F_f + F_{pau}$$

The target running resistance force F^* derived from Appendix 5 or 7 for a vehicle equipped with one wheel on the powered axle and Appendix 8 for a vehicle with two or more wheels

Status: Point in time view as at 16/12/2013.

Changes to legislation: There are currently no known outstanding effects for the Commission Delegated Regulation (EU) No 134/2014. (See end of Document for details)

on the powered axles, shall be reproduced on the chassis dynamometer in accordance with the vehicle speed, i.e.:

Equation 2-16:

$$F_E(v_i) = F^*(v_i)$$

The total friction loss F_f on the chassis dynamometer shall be measured by the method in point 5.2.2.2.1. or 5.2.2.2.2.

5.2.2.2.1. Motoring by chassis dynamometer

This method applies only to chassis dynamometers capable of driving an L-category vehicle. The test vehicle shall be driven steadily by the chassis dynamometer at the reference speed v_0 with the drive train engaged and the clutch disengaged. The total friction loss $F_f(v_0)$ at the reference speed v_0 is given by the chassis dynamometer force.

5.2.2.2.2. Coast-down without absorption

The method for measuring the coast-down time is the coast-down method for the measurement of the total friction loss F_f . The vehicle coast-down shall be performed on the chassis dynamometer by the procedure described in Appendix 5 or 7 for a vehicle equipped with one wheel on the powered axle and Appendix 8 for a vehicle equipped with two or more wheels on the powered axles, with zero chassis dynamometer absorption. The coast-down time Δt_i corresponding to the reference speed v_0 shall be measured. The measurement shall be carried out at least three times, and the mean coast-down time

$\bar{\Delta t}$

shall be calculated using the following equation:

Equation 2-17:

$$\bar{\Delta t} = \frac{1}{n} \sum_{i=1}^n \Delta t_i$$

5.2.2.2.3. Total friction loss

The total friction loss $F_{f(v_0)}$ at the reference speed v_0 is calculated using the following equation:

Equation 2-18:

$$F_f(v_0) = \frac{1}{3.6} (m_i + m_{t1}) \frac{2\Delta v}{\Delta t}$$

5.2.2.2.4. Calculation of power-absorption unit force

The force $F_{\text{pau}}(v_0)$ to be absorbed by the chassis dynamometer at the reference speed v_0 is calculated by subtracting $F_{f(v_0)}$ from the target running resistance force $F^*(v_0)$ as shown in the following equation:

Equation 2-19:

$$F_{\text{pau}}(v_0) = F^*(v_0) - F_f(v_0)$$

5.2.2.2.5. Chassis dynamometer setting

Depending on its type, the chassis dynamometer shall be set by one of the methods described in points 5.2.2.2.5.1. to 5.2.2.2.5.4. The chosen setting shall be applied to the pollutant and CO₂ emission measurements as well as for the energy efficiency measurements (fuel /energy consumption and electric range) laid down in Annex VII.

5.2.2.2.5. Chassis dynamometer with polygonal function

Status: Point in time view as at 16/12/2013.

Changes to legislation: There are currently no known outstanding effects for the Commission Delegated Regulation (EU) No 134/2014. (See end of Document for details)

In the case of a chassis dynamometer with polygonal function, in which the absorption characteristics are determined by load values at several speed points, at least three specified speeds, including the reference speed, shall be chosen as the setting points. At each setting point, the chassis dynamometer shall be set to the value F_{pau} (v_j) obtained in point 5.2.2.2.4.

5.2.2.2.5.3 Chassis dynamometer with coefficient control

In the case of a chassis dynamometer with coefficient control, in which the absorption characteristics are determined by given coefficients of a polynomial function, the value of F_{pau} (v_j) at each specified speed shall be calculated by the procedure in point 5.2.2.2.

Assuming the load characteristics to be:

Equation 2-20:

$$F_{pau}(v) = a \times v^2 + b \times v + c$$

where:

the coefficients a, b and c shall be determined by the polynomial regression method.

The chassis dynamometer shall be set to the coefficients a, b and c obtained by the polynomial regression method.

5.2.2.2.5.4 Chassis dynamometer with F^* polygonal digital setter

In the case of a chassis dynamometer with a polygonal digital setter, where a central processor unit is incorporated in the system, F^* is input directly, and Δt_i , F_f and F_{pau} are automatically measured and calculated to set the chassis dynamometer to the target running resistance force:

Equation 2-21:

$$F^* = f_0 + f_2 \times v^2$$

In this case, several points in succession are directly input digitally from the data set of F^*_j and v_j , the coast-down is performed and the coast-down time Δt_j is measured. After the coast-down test has been repeated several times, F_{pau} is automatically calculated and set at L-category vehicle speed intervals of 0,1 km/h, in the following sequence:

Equation 2-22:

$$F^* + F_f = \frac{1}{3,6} (m_i + m_{r1}) \frac{2\Delta v}{\Delta t_i}$$

Equation 2-23:

$$F_f = \frac{1}{3,6} (m_i + m_{r1}) \frac{2\Delta v}{\Delta t_i} - F^*$$

Equation 2-24:

$$F_{pau} = F^* - F_f$$

5.2.2.2.5.4 Chassis dynamometer with f^*_0 , f^*_2 coefficient digital setter

In the case of a chassis dynamometer with a coefficient digital setter, where a central processor unit is incorporated in the system, the target running resistance force

$$F^* = f_0 + f_2 \times v^2$$

is automatically set on the chassis dynamometer.

Status: Point in time view as at 16/12/2013.

Changes to legislation: There are currently no known outstanding effects for the Commission Delegated Regulation (EU) No 134/2014. (See end of Document for details)

In this case, the coefficients f_0^* and f_2^* are directly input digitally; the coast-down is performed and the coast-down time Δt_i is measured. F_{pau} is automatically calculated and set at vehicle speed intervals of 0,06 km/h, in the following sequence:

Equation 2-25:

$$F^* + F_f = \frac{1}{3,6} (m_i + m_{r1}) \frac{2\Delta v}{\Delta t_i}$$

Equation 2-26:

$$F_f = \frac{1}{3,6} (m_i + m_{r1}) \frac{2\Delta v}{\Delta t_i} - F^*$$

Equation 2-27:

$$F_{pau} = F^* - F_f$$

5.2.2.2.6. Dynamometer settings verification

5.2.2.2.6. Merification test

Immediately after the initial setting, the coast-down time Δt_E on the chassis dynamometer corresponding to the reference speed (v_0) shall be measured by the procedure set out in Appendix 5 or 7 for a vehicle equipped with one wheel on the powered axle and in Appendix 8 for a vehicle with two or more wheels on the powered axles. The measurement shall be carried out at least three times, and the mean coast-down time Δt_E shall be calculated from the results. The set running resistance force at the reference speed, $F_E(v_0)$ on the chassis dynamometer is calculated by the following equation:

Equation 2-28:

$$F_E(v_0) = \frac{1}{3,6} (m_i + m_{r1}) \frac{2\Delta v}{\Delta t_E}$$

5.2.2.2.6. Calculation of setting error

The setting error ε is calculated by the following equation:

Equation 2-29:

$$\varepsilon = \frac{|F_E(v_0) - F^*(v_0)|}{F^*(v_0)} \times 100$$

The chassis dynamometer shall be readjusted if the setting error does not satisfy the following criteria:

- $\varepsilon \leq 2$ percent for $v_0 \geq 50$ km/h
- $\varepsilon \leq 3$ percent for $30 \text{ km/h} \leq v_0 < 50 \text{ km/h}$
- $\varepsilon \leq 10$ percent for $v_0 < 30 \text{ km/h}$

The procedure in points 5.2.2.2.6.1. to 5.2.2.2.6.2. shall be repeated until the setting error satisfies the criteria. The chassis dynamometer setting and the observed errors shall be recorded. Specimen record forms are provided in the template of the test report laid down in accordance with Article 32(1) of Regulation (EU) No 168/2013.

5.2.2.3. Dynamometer preparation, if settings are derived from a running resistance table

5.2.2.3.1. The specified vehicle speed for the chassis dynamometer

The running resistance on the chassis dynamometer shall be verified at the specified vehicle speed v . At least four specified speeds shall be verified. The range of specified vehicle speed points (the interval between the maximum and minimum points) shall extend either side of the reference speed or the reference speed range, if there is more than one reference speed, by at least

Status: Point in time view as at 16/12/2013.

Changes to legislation: There are currently no known outstanding effects for the Commission Delegated Regulation (EU) No 134/2014. (See end of Document for details)

Δv , as defined in Appendix 5 or 7 for a vehicle equipped with one wheel on the powered axle and in Appendix 8 for a vehicle with two or more wheels on the powered axles. The specified speed points, including the reference speed points, shall be at regular intervals of no more than 20 km/h apart.

5.2.2.3.2. Verification of chassis dynamometer

5.2.2.3.2. Immediately after the initial setting, the coast-down time on the chassis dynamometer corresponding to the specified speed shall be measured. The vehicle shall not be set up on the chassis dynamometer during the coast-down time measurement. The coast-down time measurement shall start when the chassis dynamometer speed exceeds the maximum speed of the test cycle.

5.2.2.3.2. The measurement shall be carried out at least three times, and the mean coast-down time Δt_E shall be calculated from the results.

5.2.2.3.2. The set running resistance force $F_E(v_j)$ at the specified speed on the chassis dynamometer is calculated using the following equation:

Equation 2-30:

$$F_E(v_j) = \frac{1}{3,6} \times m_i \times \frac{2\Delta v}{\Delta t_E}$$

5.2.2.3.2. The setting error ε at the specified speed is calculated using the following equation:

Equation 2-31:

$$\varepsilon = \frac{|F_E(v_j) - F_T|}{F_T} \times 100$$

5.2.2.3.2. The chassis dynamometer shall be readjusted if the setting error does not satisfy the following criteria:

$$\varepsilon \leq 2 \text{ percent for } v \geq 50 \text{ km/h}$$

$$\varepsilon \leq 3 \text{ percent for } 30 \text{ km/h} \leq v < 50 \text{ km/h}$$

$$\varepsilon \leq 10 \text{ percent for } v < 30 \text{ km/h}$$

5.2.2.3.2. The procedure described in points 5.2.2.3.2.1. to 5.2.2.3.2.5. shall be repeated until the setting error satisfies the criteria. The chassis dynamometer setting and the observed errors shall be recorded.

5.2.2.4. The chassis dynamometer system shall comply with the calibration and verification methods laid down in Appendix 3.

5.2.3. Calibration of analysers

5.2.3.1. The quantity of gas at the indicated pressure compatible with the correct functioning of the equipment shall be injected into the analyser with the aid of the flow metre and the pressure-reducing valve mounted on each gas cylinder. The apparatus shall be adjusted to indicate as a stabilised value the value inserted on the standard gas cylinder. Starting from the setting obtained with the gas cylinder of greatest capacity, a curve shall be drawn of the deviations of the apparatus according to the content of the various standard cylinders used. The flame ionisation analyser shall be recalibrated periodically, at intervals of not more than one month, using air/propane or air/hexane mixtures with nominal hydrocarbon concentrations equal to 50 percent and 90 percent of full scale.

Status: Point in time view as at 16/12/2013.

Changes to legislation: There are currently no known outstanding effects for the Commission Delegated Regulation (EU) No 134/2014. (See end of Document for details)

5.2.3.2. Non-dispersive infrared absorption analysers shall be checked at the same intervals using nitrogen/ CO and nitrogen/ CO₂ mixtures in nominal concentrations equal to 10, 40, 60, 85 and 90 percent of full scale.

5.2.3.3. To calibrate the NO_x chemiluminescence analyser, nitrogen/nitrogen oxide (NO) mixtures with nominal concentrations equal to 50 percent and 90 percent of full scale shall be used. The calibration of all three types of analysers shall be checked before each series of tests, using mixtures of the gases, which are measured in a concentration equal to 80 percent of full scale. A dilution device can be applied for diluting a 100 percent calibration gas to required concentration.

5.2.3.4. Heated flame ionisation detector (FID) (analyser) hydrocarbon response check procedure

5.2.3.4.1. Detector response optimisation

The FID shall be adjusted according to the manufacturer's specifications. To optimise the response, propane in air shall be used on the most common operating range.

5.2.3.4.2. Calibration of the hydrocarbon analyser

The analyser shall be calibrated using propane in air and purified synthetic air (see point 5.2.3.6.).

A calibration curve shall be established as described in point 5.2.3.1 to 5.2.3.3.

5.2.3.4.3. Response factors of different hydrocarbons and recommended limits

The response factor (R_f) for a particular hydrocarbon species is the ratio of the FID C_1 reading to the gas cylinder concentration, expressed as ppm C_1 .

The concentration of the test gas shall be at a level to give a response of approximately 80 percent of full-scale deflection for the operating range. The concentration shall be known to an accuracy of 2 percent in reference to a gravimetric standard expressed in volume. In addition, the gas cylinder shall be pre-conditioned for 24 hours at a temperature of between 293,2 K and 303,2 K (20 °C and 30 °C).

Response factors shall be determined when introducing an analyser into service and thereafter at major service intervals. The test gases to be used and the recommended response factors are:

Methane and purified air: $1,00 < R_f < 1,15$

or $1,00 < R_f < 1,05$ for NG/biomethane-fuelled vehicles

Propylene and purified air: $0,90 < R_f < 1,00$

Toluene and purified air: $0,90 < R_f < 1,00$

These are relative to a response factor (R_f) of 1,00 for propane and purified air.

5.2.3.5. Calibration and verification procedures of the particulate mass emissions measurement equipment

5.2.3.5.1. Flow meter calibration

The technical service shall check that a calibration certificate has been issued for the flow meter demonstrating compliance with a traceable standard within a 12-month period prior to the test, or since any repair or change which could influence calibration.

5.2.3.5.2. Microbalance calibration

Status: Point in time view as at 16/12/2013.

Changes to legislation: There are currently no known outstanding effects for the Commission Delegated Regulation (EU) No 134/2014. (See end of Document for details)

The technical service shall check that a calibration certificate has been issued for the microbalance demonstrating compliance with a traceable standard within a 12-month period prior to the test.

5.2.3.5.3. Reference filter weighing

To determine the specific reference filter weights, at least two unused reference filters shall be weighed within eight hours of, but preferably at the same time as, the sample filter weighing. Reference filters shall be of the same size and material as the sample filter.

If the specific weight of any reference filter changes by more than $\pm 5 \mu\text{g}$ between sample filter weighings, the sample filter and reference filters shall be reconditioned in the weighing room and then reweighed.

This shall be based on a comparison of the specific weight of the reference filter and the rolling average of that filter's specific weights.

The rolling average shall be calculated from the specific weights collected in the period since the reference filters were placed in the weighing room. The averaging period shall be between one day and 30 days.

Multiple reconditioning and reweighings of the sample and reference filters are permitted up to 80 hours after the measurement of gases from the emissions test.

If, within this period, more than half the reference filters meet the $\pm 5 \mu\text{g}$ criterion, the sample filter weighing can be considered valid.

If, at the end of this period, two reference filters are used and one filter fails to meet the $\pm 5 \mu\text{g}$ criterion, the sample filter weighing may be considered valid provided that the sum of the absolute differences between specific and rolling averages from the two reference filters is no more than $10 \mu\text{g}$.

If fewer than half of the reference filters meet the $\pm 5 \mu\text{g}$ criterion, the sample filter shall be discarded and the emissions test repeated. All reference filters shall be discarded and replaced within 48 hours.

In all other cases, reference filters shall be replaced at least every 30 days and in such a manner that no sample filter is weighed without comparison with a reference filter that has been in the weighing room for at least one day.

If the weighing room stability criteria outlined in point 4.5.3.12.1.3.4. are not met but the reference filter weighings meet the criteria listed in point 5.2.3.5.3, the vehicle manufacturer has the option of accepting the sample filter weights or voiding the tests, fixing the weighing room control system and re-running the test.

Figure **Particulate sampling probe configuration**
1-6

Status: Point in time view as at 16/12/2013.

Changes to legislation: There are currently no known outstanding effects for the Commission Delegated Regulation (EU) No 134/2014. (See end of Document for details)

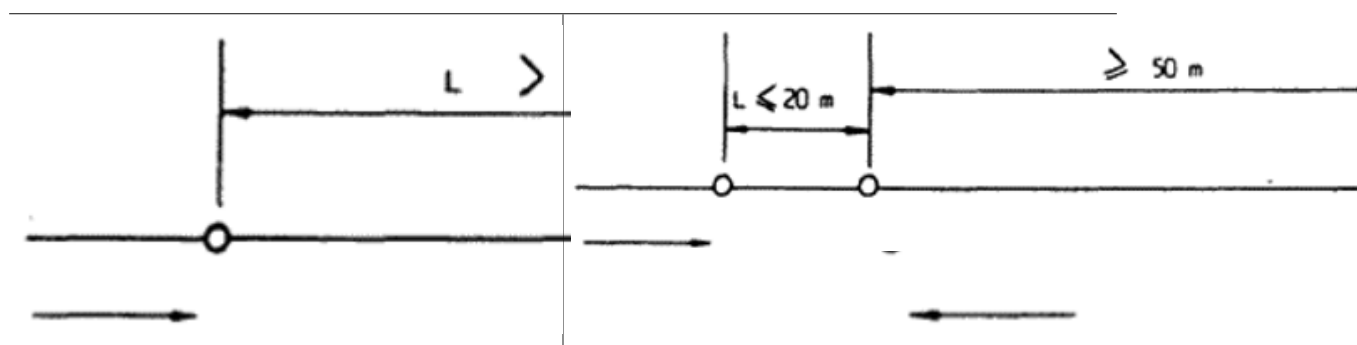

5.2.3.6. Reference gases

5.2.3.6.1. Pure gases

The following pure gases shall be available, if necessary, for calibration and operation:

Purified nitrogen: (purity: ≤ 1 ppm C₁, ≤ 1 ppm CO, ≤ 400 ppm CO₂, $\leq 0,1$ ppm NO);

Purified synthetic air: (purity: ≤ 1 ppm C₁, ≤ 1 ppm CO, ≤ 400 ppm CO₂, $\leq 0,1$ ppm NO); oxygen content between 18 and 21 percent by volume;

Purified oxygen: (purity $> 99,5$ percent vol. O₂);

Purified hydrogen (and mixture containing helium): (purity ≤ 1 ppm C₁, ≤ 400 ppm CO₂);

Carbon monoxide: (minimum purity 99,5 percent);

Propane: (minimum purity 99,5 percent).

5.2.3.6.2. Calibration and span gases

Mixtures of gases with the following chemical compositions shall be available:

- (a) C₃H₈ and purified synthetic air (see point 5.2.3.5.1.);
- (b) CO and purified nitrogen;
- (c) CO₂ and purified nitrogen;
- (d) NO and purified nitrogen (the amount of NO₂ contained in this calibration gas shall not exceed 5 percent of the NO content).

The true concentration of a calibration gas shall be within ± 2 percent of the stated figure.

5.2.3.6. Calibration and verification of the dilution system

The dilution system shall be calibrated and verified and shall comply with the requirements of Appendix 4.

5.2.4. Test vehicle preconditioning

5.2.4.1. The test vehicle shall be moved to the test area and the following operations performed:

- The fuel tanks shall be drained through the drains of the fuel tanks provided and charged with the test fuel requirement as specified in Appendix 2 to half the capacity of the tanks.
- The test vehicle shall be placed, either by being driven or pushed, on a dynamometer and operated through the applicable test cycle as specified for the vehicle

Status: Point in time view as at 16/12/2013.

Changes to legislation: There are currently no known outstanding effects for the Commission Delegated Regulation (EU) No 134/2014. (See end of Document for details)

(sub-)category in Appendix 6. The vehicle need not be cold, and may be used to set dynamometer power.

- 5.2.4.2. Practice runs over the prescribed driving schedule may be performed at test points, provided an emission sample is not taken, for the purpose of finding the minimum throttle action to maintain the proper speed-time relationship, or to permit sampling system adjustments.
- 5.2.4.3. Within five minutes of completion of preconditioning, the test vehicle shall be removed from the dynamometer and may be driven or pushed to the soak area to be parked. The vehicle shall be stored for between six and 36 hours prior to the cold start type I test or until the engine oil temperature T_O or the coolant temperature T_C or the sparkplug seat/gasket temperature T_P (only for air-cooled engine) equals the air temperature of the soak area within 2 K.
- 5.2.4.4. For the purpose of measuring particulates, between six and 36 hours before testing, the applicable test cycle from Part A of Annex VI to Regulation (EU) No 168/2013 shall be conducted on the basis of Annex IV to that Regulation. The technical details of the applicable test cycle are laid down in Appendix 6 and the applicable test cycle shall also be used for vehicle pre-conditioning. Three consecutive cycles shall be driven. The dynamometer setting shall be indicated as in point 4.5.6.
- 5.2.4.5. At the request of the manufacturer, vehicles fitted with indirect injection positive-ignition engines may be preconditioned with one Part One, one Part Two and two Part Three driving cycles, if applicable, from the WMTC.

In a test facility where a test on a low particulate emitting vehicle could be contaminated by residue from a previous test on a high particulate emitting vehicle, it is recommended that, in order to pre-condition the sampling equipment, the low particulate emitting vehicle undergo a 20 minute 120 km/h steady state drive cycle or at 70% of the maximum design speed for vehicles not capable of attaining 120 km/h followed by three consecutive Part Two or Part Three WMTC cycles, if feasible.

After this preconditioning, and before testing, vehicles shall be kept in a room in which the temperature remains relatively constant between 293,2 K and 303,2 K (20 °C and 30 °C). This conditioning shall be carried out for at least six hours and continue until the engine oil temperature and coolant, if any, are within ± 2 K of the temperature of the room.

If the manufacturer so requests, the test shall be carried out not later than 30 hours after the vehicle has been run at its normal temperature.

- 5.2.4.6. Vehicles equipped with a positive-ignition engine, fuelled with LPG, NG/biomethane, H₂NG, hydrogen or so equipped that they can be fuelled with either petrol, LPG, NG/biomethane, H₂NG or hydrogen between the tests on the first gaseous reference fuel and the second gaseous reference fuel, shall be preconditioned before the test on the second reference fuel. This preconditioning on the second reference fuel shall involve a preconditioning cycle consisting of one Part One, Part Two and two Part Three WMTC cycles, as described in Appendix 6. At the manufacturer's request and with the agreement of the technical service, this preconditioning may be extended. The dynamometer setting shall be as indicated in point 4.5.6 of this Annex.

5.2.5. Emissions tests

5.2.5.1. Engine starting and restarting

Status: Point in time view as at 16/12/2013.

Changes to legislation: There are currently no known outstanding effects for the Commission Delegated Regulation (EU) No 134/2014. (See end of Document for details)

- 5.2.5.1.1. The engine shall be started according to the manufacturer's recommended starting procedures. The test cycle run shall begin when the engine starts.
 - 5.2.5.1.2. Test vehicles equipped with automatic chokes shall be operated according to the instructions in the manufacturer's operating instructions or owner's manual covering choke-setting and 'kick-down' from cold fast idle. In the case of the WMTC set out in Appendix 6, the transmission shall be put in gear 15 seconds after the engine is started. If necessary, braking may be employed to keep the drive wheels from turning. In the case of the ECE R40 or 47 cycles, the transmission shall be put in gear five seconds before the first acceleration.
 - 5.2.5.1.3. Test vehicles equipped with manual chokes shall be operated according to the manufacturer's operating instructions or owner's manual. Where times are provided in the instructions, the point for operation may be specified, within 15 seconds of the recommended time.
 - 5.2.5.1.4. The operator may use the choke, throttle, etc. where necessary to keep the engine running.
 - 5.2.5.1.5. If the manufacturer's operating instructions or owner's manual do not specify a warm engine starting procedure, the engine (automatic and manual choke engines) shall be started by opening the throttle about half way and cranking the engine until it starts.
 - 5.2.5.1.6. If, during the cold start, the test vehicle does not start after ten seconds of cranking or ten cycles of the manual starting mechanism, cranking shall cease and the reason for failure to start determined. The revolution counter on the constant volume sampler shall be turned off and the sample solenoid valves placed in the 'standby' position during this diagnostic period. In addition, either the CVS blower shall be turned off or the exhaust tube disconnected from the tailpipe during the diagnostic period.
 - 5.2.5.1.7. If failure to start is an operational error, the test vehicle shall be rescheduled for testing from a cold start. If failure to start is caused by vehicle malfunction, corrective action (following the unscheduled maintenance provisions) lasting less than 30 minutes may be taken and the test continued. The sampling system shall be reactivated at the same time cranking is started. The driving schedule timing sequence shall begin when the engine starts. If failure to start is caused by vehicle malfunction and the vehicle cannot be started, the test shall be voided, the vehicle removed from the dynamometer, corrective action taken (following the unscheduled maintenance provisions) and the vehicle rescheduled for test. The reason for the malfunction (if determined) and the corrective action taken shall be reported.
 - 5.2.5.1.8. If the test vehicle does not start during the hot start after ten seconds of cranking or ten cycles of the manual starting mechanism, cranking shall cease, the test shall be voided, the vehicle removed from the dynamometer, corrective action taken and the vehicle rescheduled for test. The reason for the malfunction (if determined) and the corrective action taken shall be reported.
 - 5.2.5.1.9. If the engine 'false starts', the operator shall repeat the recommended starting procedure (such as resetting the choke, etc.)
- 5.2.5.2. Stalling
- 5.2.5.2.1. If the engine stalls during an idle period, it shall be restarted immediately and the test continued. If it cannot be started soon enough to allow the vehicle to follow the next

Status: Point in time view as at 16/12/2013.

Changes to legislation: There are currently no known outstanding effects for the Commission Delegated Regulation (EU) No 134/2014. (See end of Document for details)

acceleration as prescribed, the driving schedule indicator shall be stopped. When the vehicle restarts, the driving schedule indicator shall be reactivated.

5.2.5.2.2. If the engine stalls during some operating mode other than idle, the driving schedule indicator shall be stopped, the test vehicle restarted and accelerated to the speed required at that point in the driving schedule, and the test continued. During acceleration to this point, gearshifts shall be performed in accordance with point 4.5.5.

5.2.5.2.3. If the test vehicle will not restart within one minute, the test shall be voided, the vehicle removed from the dynamometer, corrective action taken and the vehicle rescheduled for test. The reason for the malfunction (if determined) and the corrective action taken shall be reported.

5.2.6. Drive instructions

5.2.6.1. The test vehicle shall be driven with minimum throttle movement to maintain the desired speed. No simultaneous use of brake and throttle shall be permitted.

5.2.6.2. If the test vehicle cannot accelerate at the specified rate, it shall be operated with the throttle fully opened until the roller speed reaches the value prescribed for that time in the driving schedule.

5.2.7. Dynamometer test runs

5.2.7.1. The complete dynamometer test consists of consecutive parts as described in point 4.5.4.

5.2.7.2. The following steps shall be taken for each test:

- (a) place drive wheel of vehicle on dynamometer without starting engine;
- (b) activate vehicle cooling fan;
- (c) for all test vehicles, with the sample selector valves in the 'standby' position, connect evacuated sample collection bags to the dilute exhaust and dilution air sample collection systems;
- (d) start the CVS (if not already on), the sample pumps and the temperature recorder. (The heat exchanger of the constant volume sampler, if used, and sample lines shall be preheated to their respective operating temperatures before the test begins);
- (e) adjust the sample flow rates to the desired flow rate and set the gas flow measuring devices to zero;
 - For gaseous bag (except hydrocarbon) samples, the minimum flow rate is 0.08 litre/second;
 - For hydrocarbon samples, the minimum flame ionisation detection (FID) (or heated flame ionisation detection (HFID) in the case of methanol-fuelled vehicles) flow rate is 0.031 litre/second;
- (f) attach the flexible exhaust tube to the vehicle tailpipes;
- (g) start the gas flow measuring device, position the sample selector valves to direct the sample flow into the 'transient' exhaust sample bag, the 'transient' dilution air sample bag, turn the key on and start cranking the engine;
- (h) put the transmission in gear;
- (i) begin the initial vehicle acceleration of the driving schedule;

- (j) operate the vehicle according to the driving cycles specified in point 4.5.4.;
- (k) at the end of part 1 or part 1 in cold condition, simultaneously switch the sample flows from the first bags and samples to the second bags and samples, switch off gas flow measuring device No 1 and start gas flow measuring device No 2;
- (l) in case of vehicles capable of running Part 3 of the WMTC, at the end of Part 2 simultaneously switch the sample flows from the second bags and samples to the third bags and samples, switch off gas flow measuring device No 2 and, start gas flow measuring device No 3;
- (m) before starting a new part, record the measured roll or shaft revolutions and reset the counter or switch to a second counter. As soon as possible, transfer the exhaust and dilution air samples to the analytical system and process the samples according to point 6., obtaining a stabilised reading of the exhaust bag sample on all analysers within 20 minutes of the end of the sample collection phase of the test;
- (n) turn the engine off two seconds after the end of the last part of the test;
- (o) immediately after the end of the sample period, turn off the cooling fan;
- (p) turn off the constant volume sampler (CVS) or critical-flow venturi (CFV) or disconnect the exhaust tube from the tailpipes of the vehicle;
- (q) disconnect the exhaust tube from the vehicle tailpipes and remove the vehicle from the dynamometer;
- (r) for comparison and analysis reasons, second-by-second emissions (diluted gas) data shall be monitored as well as the bag results.

6. Analysis of results

6.1. Type I tests

6.1.1. Exhaust emission and fuel consumption analysis

6.1.1.1. Analysis of the samples contained in the bags

The analysis shall begin as soon as possible, and in any event not later than 20 minutes after the end of the tests, in order to determine:

- the concentrations of hydrocarbons, carbon monoxide, nitrogen oxides and carbon dioxide in the sample of dilution air contained in bag(s) B;
- the concentrations of hydrocarbons, carbon monoxide, nitrogen oxides and carbon dioxide in the sample of diluted exhaust gases contained in bag(s) A.

6.1.1.2. Calibration of analysers and concentration results

The analysis of the results has to be carried out in the following steps:

- (a) prior to each sample analysis, the analyser range to be used for each pollutant shall be set to zero with the appropriate zero gas;
- (b) the analysers are set to the calibration curves by means of span gases of nominal concentrations of 70 to 100 percent of the range;
- (c) the analysers' zeros are rechecked. If the reading differs by more than 2 percent of range from that set in (b), the procedure is repeated;
- (d) the samples are analysed;

Status: Point in time view as at 16/12/2013.

Changes to legislation: There are currently no known outstanding effects for the Commission Delegated Regulation (EU) No 134/2014. (See end of Document for details)

- (e) after the analysis, zero and span points are rechecked using the same gases. If the readings are within 2 percent of those in point (c), the analysis is considered acceptable;
- (f) at all points in this section the flow-rates and pressures of the various gases shall be the same as those used during calibration of the analysers;
- (g) the figure adopted for the concentration of each pollutant measured in the gases is that read off after stabilisation on the measuring device.

6.1.1.3. Measuring the distance covered

The distance (S) actually covered for a test part shall be calculated by multiplying the number of revolutions read from the cumulative counter (see point 5.2.7.) by the circumference of the roller. This distance shall be expressed in km.

6.1.1.4. Determination of the quantity of gas emitted

The reported test results shall be computed for each test and each cycle part by use of the following formulae. The results of all emission tests shall be rounded, using the 'rounding-off method' in ASTM E 29-67, to the number of decimal places indicated by expressing the applicable standard to three significant figures.

6.1.1.4.1. Total volume of diluted gas

The total volume of diluted gas, expressed in m³/cycle part, adjusted to the reference conditions of 273,2 K (0 °C) and 101,3 kPa, is calculated by

Equation 2-32:

$$V = V_0 \times \frac{N \times (P_a - P_i) \times 273,2}{101,3 \times (T_p + 273,2)}$$

where:

V_0 is the volume of gas displaced by pump P during one revolution, expressed in m³/revolution. This volume is a function of the differences between the intake and output sections of the pump;

N is the number of revolutions made by pump P during each part of the test;

P_a is the ambient pressure in kPa;

P_i is the average under-pressure during the test part in the intake section of pump P, expressed in kPa;

T_p is the temperature (expressed in K) of the diluted gases during the test part, measured in the intake section of pump P.

6.1.1.4.2. Hydrocarbons (HC)

The mass of unburned hydrocarbons emitted by the exhaust of the vehicle during the test shall be calculated using the following formula:

Equation 2-33:

$$HC_m = \frac{1}{S} \times V \times d_{HC} \times \frac{HC}{10^6}$$

where:

HC_m is the mass of hydrocarbons emitted during the test part, in mg/km;

S is the distance defined in point 6.1.1.3.;

V is the total volume, defined in point 6.1.1.4.1.;

Status: Point in time view as at 16/12/2013.

Changes to legislation: There are currently no known outstanding effects for the Commission Delegated Regulation (EU) No 134/2014. (See end of Document for details)

d_{HC} is the density of the hydrocarbons at reference temperature and pressure (273,2 K and 101,3 kPa);

$$\begin{aligned}
 d_{HC} &= 631 \cdot 10^3 \text{ mg/m}^3 \text{ for petrol (E5) (C}_1\text{H}_{1,89}\text{O}_{0,016}\text{);} \\
 &= 932 \cdot 10^3 \text{ mg/m}^3 \text{ for ethanol (E85) (C}_1\text{H}_{2,74}\text{O}_{0,385}\text{);} \\
 &= 622 \cdot 10^3 \text{ mg/m}^3 \text{ for diesel (B5)(C}_1\text{H}_{1,86}\text{O}_{0,005}\text{);} \\
 &= 649 \cdot 10^3 \text{ mg/m}^3 \text{ for LPG (C}_1\text{H}_{2,525}\text{);} \\
 &= 714 \cdot 10^3 \text{ mg/m}^3 \text{ for NG/biogas (C}_1\text{H}_4\text{);} \\
 &= \\
 &= \frac{9,104 \times A + 196}{1524,152 - 0,583 \times A} \times 10^6 \\
 &\text{mg/m}^3 \text{ for H}_2\text{NG (with} \\
 &\quad A = \text{NG / biomethane quantity within the H}_2\text{NG mixture} \\
 &\text{in (volume \%)).}
 \end{aligned}$$

HC_c is the concentration of diluted gases, expressed in parts per million (ppm) of carbon equivalent (e.g. the concentration in propane multiplied by three), corrected to take account of the dilution air by the following equation:

Equation 2-34:

$$HC_c = HC_e - HC_d \times \left(1 - \frac{1}{DF}\right)$$

where:

HC_e is the concentration of hydrocarbons expressed in parts per million (ppm) of carbon equivalent, in the sample of diluted gases collected in bag(s) A;

HC_d is the concentration of hydrocarbons expressed in parts per million (ppm) of carbon equivalent, in the sample of dilution air collected in bag(s) B;

DF is the coefficient defined in point 6.1.1.4.7.

The non-methane hydrocarbon (NMHC) concentration is calculated as follows:

Equation 2-35:

$$C_{NMHC} = C_{THC} - (Rf_{CH_4} \times C_{CH_4})$$

where:

C_{NMHC} = corrected concentration of NMHC in the diluted exhaust gas, expressed in ppm carbon equivalent;

C_{THC} = concentration of total hydrocarbons (THC) in the diluted exhaust gas, expressed in ppm carbon equivalent and corrected by the amount of THC contained in the dilution air;

C_{CH_4} = concentration of methane (CH_4) in the diluted exhaust gas, expressed in ppm carbon equivalent and corrected by the amount of CH_4 contained in the dilution air;

Rf_{CH_4} is the FID response factor to methane as defined in point 5.2.3.4.1.

6.1.1.4.3. Carbon monoxide (CO)

The mass of carbon monoxide emitted by the exhaust of the vehicle during the test shall be calculated using the following formula:

Status: Point in time view as at 16/12/2013.

Changes to legislation: There are currently no known outstanding effects for the Commission Delegated Regulation (EU) No 134/2014. (See end of Document for details)

Equation 2-36:

$$CO_m = \frac{1}{S} \times V \times d_{CO} \times \frac{CO}{10^6}$$

where:

CO_m is the mass of carbon monoxide emitted during the test part, in mg/km;

S is the distance defined in point 6.1.1.3.;

V is the total volume defined in point 6.1.1.4.1.;

d_{CO} is the density of the carbon monoxide,

$$d_{CO} = 1,25 \times 10^6$$

mg/m³ at reference temperature and pressure (273,2 K and 101,3 kPa);

CO_c is the concentration of diluted gases, expressed in parts per million (ppm) of carbon monoxide, corrected to take account of the dilution air by the following equation:

Equation 2-37:

$$CO_c = CO_e - CO_d \times \left(1 - \frac{1}{DF}\right)$$

where:

CO_e is the concentration of carbon monoxide expressed in parts per million (ppm), in the sample of diluted gases collected in bag(s) A;

CO_d is the concentration of carbon monoxide expressed in parts per million (ppm), in the sample of dilution air collected in bag(s) B;

DF is the coefficient defined in point 6.1.1.4.7.

6.1.1.4.4. Nitrogen oxides (NO_x)

The mass of nitrogen oxides emitted by the exhaust of the vehicle during the test shall be calculated using the following formula:

Equation 2-38:

$$NO_{xm} = \frac{1}{S} \times V \times d_{NO_2} \times \frac{NO_{xc} \times K_A}{10^6}$$

where:

NO_{xm} is the mass of nitrogen oxides emitted during the test part, in mg/km;

S is the distance defined in point 6.1.1.3.;

V is the total volume defined in point 6.1.1.4.1.;

d_{NO_2} is the density of the nitrogen oxides in the exhaust gases, assuming that they will be in the form of nitric oxide,

$$d_{NO_2} = 2,05 \times 10^6$$

mg/m³ at reference temperature and pressure (273,2 K and 101,3 kPa);

NO_{xc} is the concentration of diluted gases, expressed in parts per million (ppm), corrected to take account of the dilution air by the following equation:

Equation 2-39:

$$NO_{xc} = NO_{xe} - NO_{xd} \times \left(1 - \frac{1}{DF}\right)$$

where:

NO_{xc} is the concentration of nitrogen oxides expressed in parts per million (ppm) of nitrogen oxides, in the sample of diluted gases collected in bag(s) A;

Status: Point in time view as at 16/12/2013.

Changes to legislation: There are currently no known outstanding effects for the Commission Delegated Regulation (EU) No 134/2014. (See end of Document for details)

NO_{xd} is the concentration of nitrogen oxides expressed in parts per million (ppm) of nitrogen oxides, in the sample of dilution air collected in bag(s) B;

DF is the coefficient defined in point 6.1.1.4.7.;

K_h is the humidity correction factor, calculated using the following formula:

Equation 2-40:

$$K_h = \frac{1}{1 - 0,0329 \times (H - 10,7)}$$

where:

H is the absolute humidity in g of water per kg of dry air:

Equation 2-41:

$$H = \frac{0,2111 \times U \times P_d}{P_a - P_d \times \frac{U}{100}}$$

where:

U is the humidity as a percentage;

P_d is the saturated pressure of water at the test temperature, in kPa;

P_a is the atmospheric pressure in kPa.

6.1.1.4.5. Particulate matter mass

Particulate emission M_p (mg/km) is calculated by means of the following equation:

Equation 2-42:

$$M_p = \frac{(V_{mix} + V_{ep}) \times P_e}{V_{ep} \times d}$$

where exhaust gases are vented outside the tunnel;

Equation 2-43:

$$M_p = \frac{V_{mix} \times P_e}{V_{ep} \times S}$$

where exhaust gases are returned to the tunnel;

where:

- V_{mix} = volume V of diluted exhaust gases under standard conditions;
- V_{ep} = volume of exhaust gas flowing through particulate filter under standard conditions;
- P_e = particulate mass collected by filter(s);
- S = is the distance defined in point 6.1.1.3.;
- M_p = particulate emission in mg/km.

Where correction for the particulate background level from the dilution system has been used, this shall be determined in accordance with point 5.2.1.5. In this case, the particulate mass (mg/km) shall be calculated as follows:

Equation 2-44:

$$M_p = \left[\frac{P_e}{V_{ep}} - \left(\frac{P_a}{V_{so}} \times \left(1 - \frac{1}{DF} \right) \right) \right] \times \frac{(V_{mix} + V_{ep})}{d}$$

where exhaust gases are vented outside the tunnel;

Equation 2-45:

Status: Point in time view as at 16/12/2013.

Changes to legislation: There are currently no known outstanding effects for the Commission Delegated Regulation (EU) No 134/2014. (See end of Document for details)

$$M_p = \left[\frac{P_e}{V_{ap}} - \left(\frac{P_a}{V_{ap}} \times \left(1 - \frac{1}{DF} \right) \right) \right] \times \frac{V_{mix}}{d}$$

where exhaust gases are returned to the tunnel;

where:

V_{ap} = volume of tunnel air flowing through the background particulate filter under standard conditions;

P_a = particulate mass collected by background filter;

DF = dilution factor as determined in point 6.1.1.4.7.

Where application of a background correction results in a negative particulate mass (in mg/km), the result shall be considered to be zero mg/km particulate mass.

6.1.1.4.6. Carbon dioxide (CO₂)

The mass of carbon dioxide emitted by the exhaust of the vehicle during the test shall be calculated using the following formula:

Equation 2-46:

$$CO_{2m} = \frac{1}{S} \times V \times d_{CO_2} \times \frac{CO_{2c}}{10^3}$$

where:

CO_{2m} is the mass of carbon dioxide emitted during the test part, in g/km;

S is the distance defined in point 6.1.1.3.;

V is the total volume defined in point 6.1.1.4.1.;

d_{CO_2} is the density of the carbon monoxide,

$$d_{CO_2} = 1,964 \times 10^3$$

g/m^3 at reference temperature and pressure (273,2 K and 101,3 kPa);

CO_{2c} is the concentration of diluted gases, expressed as a percentage of carbon dioxide equivalent, corrected to take account of the dilution air by the following equation:

Equation 2-47:

$$CO_{2c} = CO_{2e} - CO_{2d} \times \left(1 - \frac{1}{DF} \right)$$

where:

CO_{2e} is the concentration of carbon dioxide expressed as a percentage of the sample of diluted gases collected in bag(s) A;

CO_{2d} is the concentration of carbon dioxide expressed as a percentage of the sample of dilution air collected in bag(s) B;

DF is the coefficient defined in point 6.1.1.4.7.

6.1.1.4.7. Dilution factor (DF)

The dilution factor is calculated as follows:

For each reference fuel, except hydrogen:

Equation 2-48:

$$DF = \frac{X}{C_{CO_2} + (C_{HC} + C_{CO}) \times 10^{-4}}$$

For a fuel of composition $C_xH_yO_z$, the general formula is:

Equation 2-49:

Status: Point in time view as at 16/12/2013.

Changes to legislation: There are currently no known outstanding effects for the Commission Delegated Regulation (EU) No 134/2014. (See end of Document for details)

$$X = 100 \times \frac{x}{x + \frac{y}{2} + 3,76 \times \left(x + \frac{y}{4} - \frac{z}{2}\right)}$$

For H₂NG, the formula is:

Equation 2-50:

$$X = \frac{65,4 \times A}{4,922 \times A + 195,84}$$

For hydrogen, the dilution factor is calculated as follows:

Equation 2-51:

$$DF = \frac{X}{C_{H2O} - C_{H2O-DA} + C_{H2} \times 10^{-4}}$$

For the reference fuels contained in Appendix x, the values of 'X' are as follows:

Table 1-8

Factor 'X' in formulae to calculate DF

Fuel	X
Petrol (E5)	13,4
Diesel (B5)	13,5
LPG	11,9
NG/biomethane	9,5
Ethanol (E85)	12,5
Hydrogen	35,03

In these equations:

- C_{CO₂} = concentration of CO₂ in the diluted exhaust gas contained in the sampling bag, expressed in percent by volume,
- C_{HC} = concentration of HC in the diluted exhaust gas contained in the sampling bag, expressed in ppm carbon equivalent,
- C_{CO} = concentration of CO in the diluted exhaust gas contained in the sampling bag, expressed in ppm,
- C_{H₂O} = concentration of H₂O in the diluted exhaust gas contained in the sampling bag, expressed in percent by volume,
- C_{H₂O-DA} = concentration of H₂O in the air used for dilution, expressed in percent by volume,
- C_{H₂} = concentration of hydrogen in the diluted exhaust gas contained in the sampling bag, expressed in ppm,
- A = quantity of NG/biomethane in the H₂NG mixture, expressed in percent by volume.

6.1.1.5. Weighting of type I test results

6.1.1.5.1. With repeated measurements (see point 5.1.1.2.), the pollutant (mg/km), and CO₂ emission results obtained by the calculation method described in point 6.1.1. and fuel / energy consumption and electric range determined according to Annex VII are averaged for each cycle part.

Status: Point in time view as at 16/12/2013.

Changes to legislation: There are currently no known outstanding effects for the Commission Delegated Regulation (EU) No 134/2014. (See end of Document for details)

6.1.1.5.1. Weighting of results from UNECE regulation No 40 and regulation No 47 test cycles

The (average) result of the cold phase of UNECE regulation No 40 and of regulation No 47 test cycle is called R_1 ; the (average) result of the warm phase of UNECE regulation No 40 and of regulation No 47 test cycle is called R_2 . Using these pollutant (mg/km) and CO₂ (g/km) emission results, the final result R , depending on the vehicle class as defined in point 6.3., shall be calculated using the following equations:

Equation 2-52:

$$R = R_{1_cold} \times w_1 + R_{2_warm} \times w_2$$

where:

w_1 = weighting factor cold phase
 w_2 = weighting factor warm phase

6.1.1.5.1.2 Weighting of WMTC results

The (average) result of Part 1 or Part 1 reduced vehicle speed is called R_1 , the (average) result of Part 2 or Part 2 reduced vehicle speed is called R_2 and the (average) result of Part 3 or part 3 reduced vehicle speed is called R_3 . Using these emission (mg/km) and fuel consumption (litres/100 km) results, the final result R , depending on the vehicle category as defined in point 6.1.1.6.2., shall be calculated using the following equations:

Equation 2-53:

$$R = R_1 \times w_1 + R_2 \times w_2$$

where:

w_1 = weighting factor cold phase
 w_2 = weighting factor warm phase

Equation 2-54:

$$R = R_1 \times w_1 + R_2 \times w_2 + R_3 \times w_3$$

where:

w_n = weighting factor phase n ($n=1, 2$ or 3)

6.1.1.6.2. For each pollutant emission constituent, the carbon dioxide emission weightings shown in Tables 1-9 (Euro 4) and 1-10 (Euro 5) shall be used.

6.1.1.6.2.1. *TABLE 1-9*

Type I test cycles (also applicable for test types VII and VIII) for Euro 4 compliant L-category vehicles, applicable weighting equations and weighting factors

Vehicle category	Vehicle category name	Test cycle	Equation number	Weighting factors
L1e-A	Powered cycle	ECE R47	2-52	$w_1 = 0,30$ $w_2 = 0,70$
L1e-B	Two-wheel moped			
L2e	Three-wheel moped			

Status: Point in time view as at 16/12/2013.

Changes to legislation: There are currently no known outstanding effects for the Commission Delegated Regulation (EU) No 134/2014. (See end of Document for details)

L6e-A	Light on-road quad			
L6e-B	Light quadri-mobile			
L3e L4e	Two-wheel motorcycle with and without side-car $v_{\max} < 130 \text{ km/h}$	WMTC, stage 2	2-53	$w_1 = 0,30$ $w_2 = 0,70$
L5e-A	Tricycle $v_{\max} < 130 \text{ km/h}$			
L7e-A	Heavy on-road quad $v_{\max} < 130 \text{ km/h}$			
L3e L4e	Two-wheel motorcycle with and without side-car $v_{\max} \geq 130 \text{ km/h}$	WMTC, stage 2	2-54	$w_1 = 0,25$ $w_2 = 0,50$ $w_3 = 0,25$
L5e-A	Tricycle $v_{\max} \geq 130 \text{ km/h}$			
L7e-A	Heavy on-road quad $v_{\max} \geq 130 \text{ km/h}$			
L5e-B	Commercial tricycle	ECE R40	2-52	$w_1 = 0,30$ $w_2 = 0,70$
L7e-B	All-terrain vehicles			
L7e-C	Heavy quadri-mobile			

6.1.1.6.2.2.

TABLE 1-10

Type I test cycles (also applicable for test types VII and VIII) for Euro 5 compliant L-category vehicles, applicable weighting equations and weighting factors

Vehicle category	Vehicle category name	Test cycle	Equation #	Weighting factors
------------------	-----------------------	------------	------------	-------------------

Status: Point in time view as at 16/12/2013.

Changes to legislation: There are currently no known outstanding effects for the Commission Delegated Regulation (EU) No 134/2014. (See end of Document for details)

L1e-A	Powered cycle	WMTC stage 3	2-53	$w_1 = 0,50$ $w_2 = 0,50$
L1e-B	Two-wheel moped			
L2e	Three-wheel moped			
L6e-A	Light on-road quad			
L6e-B	Light quadrimobile			
L3e L4e	Two-wheel motorcycle with and without side-car $v_{\max} < 130 \text{ km/h}$		2-53	$w_1 = 0,50$ $w_2 = 0,50$
L5e-A	Tricycle $v_{\max} < 130 \text{ km/h}$			
L7e-A	Heavy on-road quad $v_{\max} < 130 \text{ km/h}$			
L3e L4e	Two-wheel motorcycle with and without side-car $v_{\max} \geq 130 \text{ km/h}$		2-54	$w_1 = 0,25$ $w_2 = 0,50$ $w_3 = 0,25$
L5e-A	Tricycle $v_{\max} \geq 130 \text{ km/h}$			
L7e-A	Heavy on-road quad $v_{\max} \geq 130 \text{ km/h}$			
L5e-B	Commercial tricycle			
L7e-B	All-terrain vehicles		2-53	$w_1 = 0,30$ $w_2 = 0,70$
L7e-C	Heavy quadrimobile			

7. Records required

Status: Point in time view as at 16/12/2013.

Changes to legislation: There are currently no known outstanding effects for the Commission Delegated Regulation (EU) No 134/2014. (See end of Document for details)

The following information shall be recorded with respect to each test:

- (a) test number;
- (b) vehicle, system or component identification;
- (c) date and time of day for each part of the test schedule;
- (d) instrument operator;
- (e) driver or operator;
- (f) test vehicle: make, vehicle identification number, model year, drivetrain / transmission type, odometer reading at initiation of preconditioning, engine displacement, engine family, emission-control system, recommended engine speed at idle, nominal fuel tank capacity, inertial loading, reference mass recorded at 0 kilometre, and drive-wheel tyre pressure;
- (g) dynamometer serial number: as an alternative to recording the dynamometer serial number, a reference to a vehicle test cell number may be used, with the advance approval of the Administration, provided the test cell records show the relevant instrument information;
- (h) all relevant instrument information, such as tuning, gain, serial number, detector number, range. As an alternative, a reference to a vehicle test cell number may be used, with the advance approval of the Administration, provided test cell calibration records show the relevant instrument information;
- (i) recorder charts: identify zero point, span check, exhaust gas, and dilution air sample traces;
- (j) test cell barometric pressure, ambient temperature and humidity;
Note 7: A central laboratory barometer may be used; provided that individual test cell barometric pressures are shown to be within $\pm 0,1$ percent of the barometric pressure at the central barometer location.
- (k) pressure of the mixture of exhaust and dilution air entering the CVS metering device, the pressure increase across the device, and the temperature at the inlet. The temperature shall be recorded continuously or digitally to determine temperature variations;
- (l) the number of revolutions of the positive displacement pump accumulated during each test phase while exhaust samples are being collected. The number of standard cubic meters metered by a critical-flow venturi (CFV) during each test phase would be the equivalent record for a CFV-CVS;
- (m) the humidity of the dilution air.
Note 8: If conditioning columns are not used, this measurement can be deleted. If the conditioning columns are used and the dilution air is taken from the test cell, the ambient humidity can be used for this measurement;
- (n) the driving distance for each part of the test, calculated from the measured roll or shaft revolutions;
- (o) the actual roller speed pattern for the test;
- (p) the gear use schedule for the test;

Status: Point in time view as at 16/12/2013.

Changes to legislation: There are currently no known outstanding effects for the Commission Delegated Regulation (EU) No 134/2014. (See end of Document for details)

- (q) the emissions results of the type I test for each part of the test and the total weighted test results;
- (r) the second-by-second emission values of the type I tests, if deemed necessary;
- (s) the emissions results of the type II test (see Annex III).

Status: Point in time view as at 16/12/2013.

Changes to legislation: There are currently no known outstanding effects for the Commission Delegated Regulation (EU) No 134/2014. (See end of Document for details)

Appendix 1

Symbols used in Annex II

Table A_p Symbols used in Annex II

1-1

Symbol	Definition	Unit
a	Coefficient of polygonal function	—
a _T	Rolling resistance force of front wheel	N
b	Coefficient of polygonal function	—
b _T	Coefficient of aerodynamic function	$N / (km / h)^2$
c	Coefficient of polygonal function	—
C _{CO}	Concentration of carbon monoxide	percent vol.
C _{CO_{corr}}	Corrected concentration of carbon monoxide	percent vol.
CO _{2c}	Carbon dioxide concentration of diluted gas, corrected to take account of diluent air	percent
CO _{2d}	Carbon dioxide concentration in the sample of diluent air collected in bag B	percent
CO _{2e}	Carbon dioxide concentration in the sample of diluent air collected in bag A	percent
CO _{2m}	Mass of carbon dioxide emitted during the test part	g/km
CO _c	Carbon monoxide concentration of diluted gas, corrected to take account of diluent air	ppm
CO _d	Carbon monoxide concentration in the sample of diluent air, collected in bag B	ppm
CO _e	Carbon monoxide concentration in the sample	ppm

Status: Point in time view as at 16/12/2013.

Changes to legislation: There are currently no known outstanding effects for the Commission Delegated Regulation (EU) No 134/2014. (See end of Document for details)

	of diluent air, collected in bag A	
CO_m	Mass of carbon monoxide emitted during the test part	mg/km
d_0	Standard ambient relative air density	—
d_{CO}	Density of carbon monoxide	mg/m ³
d_{CO_2}	Density of carbon dioxide	mg/m ³
DF	Dilution factor	—
d_{HC}	Density of hydrocarbon	mg/m ³
S / d	Distance driven in a cycle part	km
d_{NO_x}	Density of nitrogen oxide	mg/m ³
d_T	Relative air density under test condition	—
Δt	Coast-down time	s
Δt_{ai}	Coast-down time measured in the first road test	s
Δt_{bi}	Coast-down time measured in the second road test	s
ΔT_E	Coast-down time corrected for the inertia mass	s
Δt_E	Mean coast-down time on the chassis dynamometer at the reference speed	s
ΔT_i	Average coast-down time at specified speed	s
Δt_i	Coast-down time at corresponding speed	s
ΔT_j	Average coast-down time at specified speed	s
ΔT_{road}	Target coast-down time	s
$\bar{\Delta t}$	Mean coast-down time on the chassis dynamometer without absorption	s
Δv	Coast-down speed interval ($2\Delta v = v_1 - v_2$)	km/h
ε	Chassis dynamometer setting error	percent

Status: Point in time view as at 16/12/2013.

Changes to legislation: There are currently no known outstanding effects for the Commission Delegated Regulation (EU) No 134/2014. (See end of Document for details)

F	Running resistance force	N
F*	Target running resistance force	N
F* _(v0)	Target running resistance force at reference speed on chassis dynamometer	N
F* _(vi)	Target running resistance force at specified speed on chassis dynamometer	N
f* ₀	Corrected rolling resistance in the standard ambient condition	N
f* ₂	Corrected coefficient of aerodynamic drag in the standard ambient condition	$N / (km / h)^2$
F* _j	Target running resistance force at specified speed	N
f ₀	Rolling resistance	N
f ₂	Coefficient of aerodynamic drag	$N / (km / h)^2$
F _E	Set running resistance force on the chassis dynamometer	N
F _{E(v0)}	Set running resistance force at the reference speed on the chassis dynamometer	N
F _{E(v2)}	Set running resistance force at the specified speed on the chassis dynamometer	N
F _f	Total friction loss	N
F _{f(v0)}	Total friction loss at the reference speed	N
F _j	Running resistance force	N
F _{j(v0)}	Running resistance force at the reference speed	N
F _{pau}	Braking force of the power absorbing unit	N
F _{pau(v0)}	Braking force of the power absorbing unit at the reference speed	N
F _{pau(vj)}	Braking force of the power absorbing unit at the specified speed	N

Status: Point in time view as at 16/12/2013.

Changes to legislation: There are currently no known outstanding effects for the Commission Delegated Regulation (EU) No 134/2014. (See end of Document for details)

F_T	Running resistance force obtained from the running resistance table	N
H	Absolute humidity	mg/km
HC_c	Concentration of diluted gases expressed in the carbon equivalent, corrected to take account of diluent air	ppm
HC_d	Concentration of hydrocarbons expressed in the carbon equivalent, in the sample of diluent air collected in bag B	ppm
HC_e	Concentration of hydrocarbons expressed in the carbon equivalent, in the sample of diluent air collected in bag A	ppm
HC_m	Mass of hydrocarbon emitted during the test part	mg/km
K_0	Temperature correction factor for rolling resistance	—
K_h	Humidity correction factor	—
L	Limit values of gaseous emission	mg/km
m	Test L-category vehicle mass	kg
m_a	Actual mass of the test L-category vehicle	kg
m_{fi}	Flywheel equivalent inertia mass	kg
m_i	Equivalent inertia mass	kg
m_k	Kerb mass (L-category vehicle)	kg
m_r	Equivalent inertia mass of all the wheels	kg
m_{ri}	Equivalent inertia mass of all the rear wheel and L-category vehicle parts rotating with wheel	kg
m_{ref}	Mass in running order of the L-category vehicle plus mass of driver (75 kg)	kg

Status: Point in time view as at 16/12/2013.

Changes to legislation: There are currently no known outstanding effects for the Commission Delegated Regulation (EU) No 134/2014. (See end of Document for details)

m_{rf}	Rotating mass of the front wheel	kg
m_{rid}	Rider mass	kg
n	Engine speed	min^{-1}
n	Number of data regarding the emission or the test	—
N	Number of revolution made by pump P	—
ng	Number of forward gears	—
n_{idle}	Idling speed	min^{-1}
$n_{max_acc(1)}$	Upshift speed from gear 1 to gear 2 during acceleration phases	min^{-1}
$n_{max_acc(i)}$	Up shift speed from gear i to gear $i+1$ during acceleration phases, $i > 1$	min^{-1}
$n_{min_acc(i)}$	Minimum engine speed for cruising or deceleration in gear i	min^{-1}
NO_{xc}	Nitrogen oxide concentration of diluted gases, corrected to take account of diluent air	ppm
NO_{xd}	Nitrogen oxide concentration in the sample of diluent air collected in bag B	ppm
NO_{xe}	Nitrogen oxide concentration in the sample of diluent air collected in bag A	ppm
NO_{xm}	Mass of nitrogen oxides emitted during the test part	mg/km
P_0	Standard ambient pressure	kPa
P_a	Ambient/atmospheric pressure	kPa
P_d	Saturated pressure of water at the test temperature	kPa
P_i	Average under-pressure during the test part in the section of pump P	kPa
P_n	Rated engine power	kW
P_T	Mean ambient pressure during the test	kPa

Status: Point in time view as at 16/12/2013.

Changes to legislation: There are currently no known outstanding effects for the Commission Delegated Regulation (EU) No 134/2014. (See end of Document for details)

ρ_0	Standard relative ambient air volumetric mass	kg/m^3
$r(i)$	Gear ratio in gear i	—
R	Final test result of pollutant emissions, carbon dioxide emission or fuel consumption	mg/km, g/km, 1/100 km
R_1	Test results of pollutant emissions, carbon dioxide emission or fuel consumption for cycle part 1 with cold start	mg/km, g/km, 1/100 km
R_2	Test results of pollutant emissions, carbon dioxide emission or fuel consumption for cycle part 2 with warm condition	mg/km, g/km, 1/100 km
R_3	Test results of pollutant emissions, carbon dioxide emission or fuel consumption for cycle part 1 with warm condition	mg/km, g/km, 1/100 km
R_{i_1}	First type I test results of pollutant emissions	mg/km
R_{i_2}	Second type I test results of pollutant emissions	mg/km
R_{i_3}	Third type I test results of pollutant emissions	mg/km
s	Rated engine speed	min^{-1}
T^C	Temperature of the coolant	K
T^O	Temperature of the engine oil	K
T^P	Temperature of the spark-plug seat/gasket	K
T_0	Standard ambient temperature	K
T_p	Temperature of the diluted gases during the test part, measured in the intake section of pump P	K
T_T	Mean ambient temperature during the test	K
U	humidity	percent
v	Specified speed	

Status: Point in time view as at 16/12/2013.

Changes to legislation: There are currently no known outstanding effects for the Commission Delegated Regulation (EU) No 134/2014. (See end of Document for details)

V	Total volume of diluted gas	m ³
v _{max}	Maximum design speed of test vehicle (L-category vehicle)	km/h
v ₀	Reference vehicle speed	km/h
V ₀	Volume of gas displaced by pump P during one revolution	m ³ /rev.
v ₁	Vehicle speed at which the measurement of the coast-down time begins	km/h
v ₂	Vehicle speed at which the measurement of the coast-down time ends	km/h
v _i	Specified vehicle speed selected for the coast-down time measurement	km/h
w ₁	Weighting factor of cycle part 1 with cold start	—
w _{1hot}	Weighting factor of cycle part 1 with warm condition	—
w ₂	Weighting factor of cycle part 2 with warm condition	—
w ₃	Weighting factor of cycle part 3 with warm condition	—

Status: Point in time view as at 16/12/2013.

Changes to legislation: There are currently no known outstanding effects for the Commission Delegated Regulation (EU) No 134/2014. (See end of Document for details)

Appendix 2

Reference fuels

1. Specifications of reference fuels for testing vehicles in environmental tests, in particular for tailpipe and evaporative emissions testing

- 1.1. The following tables list the technical data on liquid reference fuels to be used for environmental performance testing. The fuel specifications in this Appendix are consistent with the reference fuel specifications in Annex 10 to UNECE regulation No 83 Revision 4.

Type: Petrol (E5)				
Parameter	Unit	Limits ^a		Test method
		Minimum	Maximum	
Research octane number, RON		95,0	—	EN 25164 / prEN ISO 5164
Motor octane number, MON		85,0	—	EN 25163 / prEN ISO 5163
Density at 15 °C	kg/m ³	743	756	EN ISO 3675 / EN ISO 12185
Vapour pressure	kPa	56,0	60,0	EN ISO 13016-1 (DVPE)
Water content	% v/v		0,015	ASTM E 1064
Distillation:				
— Evaporated at 70 °C	% v/v	24,0	44,0	EN ISO 3405
— Evaporated at 100 °C	% v/v	48,0	60,0	EN ISO 3405
— Evaporated at 150 °C	% v/v	82,0	90,0	EN ISO 3405
— Final boiling point	°C	190	210	EN ISO 3405
Residue	% v/v	—	2,0	EN ISO 3405
Hydrocarbon analysis:				
— Olefins	% v/v	3,0	13,0	ASTM D 1319

Status: Point in time view as at 16/12/2013.

Changes to legislation: There are currently no known outstanding effects for the Commission Delegated Regulation (EU) No 134/2014. (See end of Document for details)

—	Aromatics	% v/v	29,0	35,0	ASTM D 1319
—	Benzene	% v/v	—	1,0	EN 12177
—	Saturates	% v/v	Report		ASTM 1319
	Carbon/hydrogen ratio		Report		
	Carbon/oxygen ratio		Report		
	Induction period ^b	minutes	480	—	EN ISO 7536
	Oxygen content ^d	% m/m	Report		EN 1601
	Existent gum	mg/ml	—	0,04	EN ISO 6246
	Sulphur content ^c	mg/kg	—	10	EN ISO 20846 / EN ISO 20884
	Copper corrosion		—	Class 1	EN ISO 2160
	Lead content	mg/l	—	5	EN 237
	Phosphorus content	mg/l	—	1,3	ASTM D 3231
	Ethanol ^e	% v/v	4,7	5,3	EN 1601 / EN 13132

a The values quoted in the specifications are 'true values'. For establishing the limit values, the terms of ISO 4259:2006 (Petroleum products — Determination and application of precision data in relation to methods of test) have been applied and for fixing a minimum value, a minimum difference of 2R above zero has been taken into account; for fixing a maximum and minimum value, the minimum difference is 4R (R = reproducibility). Notwithstanding this measure, which is necessary for technical reasons, the fuel manufacturer shall nevertheless aim at a zero value where the stipulated maximum value is 2R and at the mean value when quoting maximum and minimum limits. Should it be necessary to clarify whether a fuel meets the requirements of the specifications, the terms of ISO 4259:2006 shall be applied.

b The fuel may contain oxidation inhibitors and metal deactivators normally used to stabilise refinery petrol streams, but detergent/dispersive additives and solvent oils shall not be added.

c The actual sulphur content of the fuel used for the type I test shall be reported.

d Ethanol meeting the specification of prEN 15376 is the only oxygenate that shall be intentionally added to the reference fuel.

e There shall be no intentional addition to this reference fuel of compounds containing phosphorus, iron, manganese or lead.

Type: Ethanol (E85)

Parameter	Unit	Limits ^a		Test method ^b
		Minimum	Maximum	
Research octane number, RON		95,0	—	EN ISO 5164
Motor octane number, MON		85,0	—	EN ISO 5163
Density at 15 °C	kg/m ³	Report		ISO 3675

Status: Point in time view as at 16/12/2013.

Changes to legislation: There are currently no known outstanding effects for the Commission Delegated Regulation (EU) No 134/2014. (See end of Document for details)

Vapour pressure	kPa	40,0	60,0	EN ISO 13016-1 (DVPE)
Sulphur content ^{cd}	mg/kg	—	10	EN ISO 20846 EN ISO 20884
Oxidation stability	minutes	360		EN ISO 7536
Existent gum content (solvent washed)	mg/(100 ml)	—	5	EN ISO 6246
Appearance This shall be determined at ambient temperature or 15 °C, whichever is higher.		Clear and bright, visibly free of suspended or precipitated contaminants		Visual inspection
Ethanol and higher alcohols ^g	% V/V	83	85	EN 1601 EN 13132 EN 14517
Higher alcohols (C3-C8)	% V/V	—	2,0	
Methanol	% V/V		0,5	
Petrol ^e	% V/V	Balance		EN 228
Phosphorus	mg/l	0,3 ^f		ASTM D 3231
Water content	% V/V		0,3	ASTM E 1064
Inorganic chloride content	mg/l		1	ISO 6227
pHe		6,5	9,0	ASTM D 6423
Copper strip corrosion (3h at 50 °C)	Rating	Class 1		EN ISO 2160
Acidity (as acetic acid CH ₃ COOH)	% m/m (mg/l)	—	0,005 (40)	ASTM D 1613
Carbon/hydrogen ratio		report		
Carbon/oxygen ration		report		

- a** The values quoted in the specifications are 'true values'. For establishing the limit values, the terms of ISO 4259:2006 (Petroleum products — Determination and application of precision data in relation to methods of test) have been applied and for fixing a minimum value, a minimum difference of 2R above zero has been taken into account; for fixing a maximum and minimum value, the minimum difference is 4R (R = reproducibility). Notwithstanding this measure, which is necessary for technical reasons, the fuel manufacturer shall nevertheless aim at a zero value where the stipulated maximum value is 2R and at the mean value when quoting maximum and minimum

Status: Point in time view as at 16/12/2013.

Changes to legislation: There are currently no known outstanding effects for the Commission Delegated Regulation (EU) No 134/2014. (See end of Document for details)

limits. Should it be necessary to clarify whether a fuel meets the requirements of the specifications, the terms of ISO 4259:2006 shall be applied.

- b** In cases of dispute, the procedures for resolving the dispute and interpreting the results based on test method precision, as described in EN ISO 4259:2006, shall be used.
- c** In cases of national dispute concerning sulphur content, either EN ISO 20846:2011 or EN ISO 20884:2011 shall be referred to in the same way as in the national annex of EN 228.
- d** The actual sulphur content of the fuel used for the type I test shall be reported.
- e** The unleaded petrol content can be determined as 100 minus the sum of the percentage content of water and alcohols.
- f** There shall be no intentional addition to this reference fuel of compounds containing phosphorus, iron, manganese or lead.
- g** Ethanol meeting the specification of EN 15376 is the only oxygenate that shall be intentionally added to this reference fuel.

Type: Diesel fuel (B5)

Parameter	Unit	Limits ^a		Test method
		Minimum	Maximum	
Cetane number ^b		52,0	54,0	EN ISO 5165
Density at 15 °C	kg/m ³	833	837	EN ISO 3675
Distillation:				
— 50 % point	°C	245	—	EN ISO 3405
— 95 % point	°C	345	350	EN ISO 3405
— Final boiling point	°C	—	370	EN ISO 3405
Flash point	°C	55	—	EN 22719
CFPP	°C	—	-5	EN 116
Viscosity at 40 °C	mm ² /s	2,3	3,3	EN ISO 3104
Polycyclic aromatic hydrocarbons	% m/m	2,0	6,0	EN 12916
Sulphur content ^c	mg/kg	—	10	EN ISO 20846 / EN ISO 20884
Copper corrosion		—	Class 1	EN ISO 2160
Conradson carbon residue (10 % DR)	% m/m	—	0,2	EN ISO 10370
Ash content	% m/m	—	0,01	EN ISO 6245
Water content	% m/m	—	0,02	EN ISO 12937

Status: Point in time view as at 16/12/2013.

Changes to legislation: There are currently no known outstanding effects for the Commission Delegated Regulation (EU) No 134/2014. (See end of Document for details)

Neutralisation (strong acid) number	mg KOH/g	—	0,02	ASTM D 974
Oxidation stability ^d	mg/ml	—	0,025	EN ISO 12205
Lubricity (HFRR wear scan diameter at 60 °C)	µm	—	400	EN ISO 12156
Oxidation stability at 110 °C ^{df}	h	20,0		EN 14112
FAME ^e	% v/v	4,5	5,5	EN 14078

a The values quoted in the specifications are 'true values'. For establishing the limit values, the terms of ISO 4259:2006 (Petroleum products — Determination and application of precision data in relation to methods of test) have been applied and for fixing a minimum value, a minimum difference of 2R above zero has been taken into account; for fixing a maximum and minimum value, the minimum difference is 4R (R = reproducibility). Notwithstanding this measure, which is necessary for technical reasons, the fuel manufacturer shall nevertheless aim at a zero value where the stipulated maximum value is 2R and at the mean value when quoting maximum and minimum limits. Should it be necessary to clarify whether a fuel meets the requirements of the specifications, the terms of ISO 4259:2006 shall be applied.

b The range for Cetane number is not in accordance with the requirements of a minimum range of 4R. However, the terms of ISO 4259:2006 may be used to resolve disputes between fuel supplier and fuel user, provided replicate measurements, of sufficient number to archive the necessary precision, are taken in preference to single determinations.

c The actual sulphur content of the fuel used for the type I test shall be reported.

d Even though oxidation stability is controlled, it is likely that shelf life will be limited. Advice shall be sought from the supplier as to storage conditions and shelf life.

e FAME content to meet the specification of EN 14214.

f Oxidation stability can be demonstrated by EN ISO 12205:1995 or EN 14112:1996. This requirement shall be reviewed based on CEN/TC19 evaluations of oxidative stability performance and test limits.

Type: Liquefied petroleum gas (LPG)

Parameter	Unit	Fuel A	Fuel B	Test method
Composition:				ISO 7941
C ₃ -content	percent vol	30 ± 2	85 ± 2	
C ₄ -content	percent vol	Balance ^a	Balance ^b	
< C ₃ , > C ₄	percent vol	max. 2	max. 2	
Olefins	percent vol	max. 12	max. 15	
Evaporation residue	mg/kg	max. 50	max. 50	ISO 13757 or EN 15470
Water at 0 °C		free	free	EN 15469

a Balance has to be read as follows:

$$\text{balance} = 100 - C_3 \leq C_3 \leq C_4$$

b This method may not accurately determine the presence of corrosive materials if the sample contains corrosion inhibitors or other chemicals which diminish the corrosivity of the sample to the copper strip. Therefore, the addition of such compounds for the sole purpose of biasing the test method is prohibited.

Status: Point in time view as at 16/12/2013.

Changes to legislation: There are currently no known outstanding effects for the Commission Delegated Regulation (EU) No 134/2014. (See end of Document for details)

Total sulphur content	mg/kg	max. 50	max. 50	EN 24260 or ASTM 6667
Hydrogen sulphide		none	none	ISO 8819
Copper strip corrosion	rating	Class 1	class 1	ISO 6251 ^b
Odour		characteristic	characteristic	
Motor octane number		min. 89	min. 89	EN 589 Annex B

a Balance has to be read as follows:

$$\text{balance} = 100 - C3 \leq C3 \geq C4$$

b This method may not accurately determine the presence of corrosive materials if the sample contains corrosion inhibitors or other chemicals which diminish the corrosivity of the sample to the copper strip. Therefore, the addition of such compounds for the sole purpose of biasing the test method is prohibited.

Type: Natural gas (NG)/biomethane^a

Parameter	Unit	Limits ^c		Test method
		Minimum	Maximum	
Reference fuel G₂₀				
Methane	percent mole	100	99	100
Balance ^b	percent mole	—	—	1
N ₂	percent mole			
Sulphur content ^b	mg/m ³	—	—	10
Wobbe Index ^d (net)	MJ/m ³	48,2	47,2	49,2
Reference fuel G₂₅				
Methane	percent mole	86	84	88
Balance ^b	percent mole	—	—	1
N ₂	percent mole	14	12	16
Sulphur content ^c	mg/m ³	—	—	10
Wobbe Index (net) ^d	MJ/m ³	39,4	38,2	40,6

a Biofuel^a means liquid or gaseous fuel for transport, produced from biomass.

b Inerts (different from N₂) + C₂ + C₂₊.

c Value to be determined at 293,2 K (20 °C) and 101,3 kPa.

d Value to be determined at 273,2 K (0 °C) and 101,3 kPa.

Status: Point in time view as at 16/12/2013.

Changes to legislation: There are currently no known outstanding effects for the Commission Delegated Regulation (EU) No 134/2014. (See end of Document for details)

Type: Hydrogen for internal combustion engines				
Parameter	Unit	Limits		Test method
		Minimum	Maximum	
Hydrogen purity	% mole	98	100	ISO 14687
Total hydrocarbon	µmol/mol	0	100	ISO 14687
Water ^a	µmol/mol	0	^b	ISO 14687
Oxygen	µmol/mol	0	^b	ISO 14687
Argon	µmol/mol	0	^b	ISO 14687
Nitrogen	µmol/mol	0	^b	ISO 14687
CO	µmol/mol	0	1	ISO 14687
Sulphur	µmol/mol	0	2	ISO 14687
Permanent particulates ^c				ISO 14687

^a Not to be condensed.

^b Combined water, oxygen, nitrogen and argon: 1 900 µmol/mol.

^c The hydrogen shall not contain dust, sand, dirt, gums, oils or other substances in an amount sufficient to damage the fuelling station equipment of the vehicle (engine) being fuelled.

Type: Hydrogen for hydrogen fuel cell vehicles				
Parameter	Unit	Limits		Test method
		Minimum	Maximum	
Hydrogen fuel ^a	% mole	99,99	100	ISO 14687-2
Total gases ^b	µmol/mol	0	100	
Total hydrocarbon	µmol/mol	0	2	ISO 14687-2
Water	µmol/mol	0	5	ISO 14687-2
Oxygen	µmol/mol	0	5	ISO 14687-2
Helium (He), Nitrogen (N ₂), Argon (Ar)	µmol/mol	0	100	ISO 14687-2
CO ₂	µmol/mol	0	2	ISO 14687-2
CO	µmol/mol	0	0,2	ISO 14687-2
Total sulphur compounds	µmol/mol	0	0,004	ISO 14687-2

^a The hydrogen fuel index is determined by subtracting the total content of non-hydrogen gaseous constituents listed in the table (total gases), expressed in mole percent, from 100 mole percent. It is less than the sum of the maximum allowable limits of all non-hydrogen constituents shown in the table.

^b The value of total gases is the sum of the values of the non-hydrogen constituents listed in the table, except the particulates.

Status: Point in time view as at 16/12/2013.

Changes to legislation: There are currently no known outstanding effects for the Commission Delegated Regulation (EU) No 134/2014. (See end of Document for details)

Formaldehyde (HCHO)	µmol/mol	0	0,01	ISO 14687-2
Formic acid (HCOOH)	µmol/mol	0	0,2	ISO 14687-2
Ammonia (NH ₃)	µmol/mol	0	0,1	ISO 14687-2
Total halogenated compounds	µmol/mol	0	0,05	ISO 14687-2
Particulates size	µm	0	10	ISO 14687-2
Particulates concentration	µg/l	0	1	ISO 14687-2

a The hydrogen fuel index is determined by subtracting the total content of non-hydrogen gaseous constituents listed in the table (total gases), expressed in mole percent, from 100 mole percent. It is less than the sum of the maximum allowable limits of all non-hydrogen constituents shown in the table.

b The value of total gases is the sum of the values of the non-hydrogen constituents listed in the table, except the particulates.

Status: Point in time view as at 16/12/2013.

Changes to legislation: There are currently no known outstanding effects for the Commission Delegated Regulation (EU) No 134/2014. (See end of Document for details)

Appendix 3

Chassis dynamometer system

1. Specification

1.1. General requirements

1.1.1. The dynamometer shall be capable of simulating road load within one of the following classifications:

- (a) dynamometer with fixed load curve, i.e. a dynamometer whose physical characteristics provide a fixed load curve shape;
- (b) dynamometer with adjustable load curve, i.e. a dynamometer with at least two road load parameters that can be adjusted to shape the load curve.

1.1.2. Dynamometers with electric inertia simulation shall be demonstrated to be equivalent to mechanical inertia systems. The means by which equivalence is established are described in point 4.

1.1.3. Where the total resistance to progress on the road cannot be reproduced on the chassis dynamometer between speeds of 10 km/h and 120 km/h, it is recommended that a chassis dynamometer with the characteristics defined in point 1.2. should be used.

1.1.3.1. The load absorbed by the brake and the chassis dynamometer (internal frictional effects) between the speeds of 0 and 120 km/h is as follows:

Equation Ap3-1:

$$F = (a + b \times v^2) \pm 0,1 \times F_{80}$$

(without being negative)

where:

- F = total load absorbed by the chassis dynamometer (N);
- a = value equivalent to rolling resistance (N);
- b = value equivalent to coefficient of air resistance (N/(km/h)²);
- v = vehicle speed (km/h);
- F₈₀ = load at 80 km/h (N). Alternatively for vehicles that cannot attain 80 km/h the load at the reference vehicle speeds v_j in table Ap8-1 in Appendix 8 shall be determined.

1.2. Specific requirements

1.2.1. The setting of the dynamometer shall not be affected by the lapse of time. It shall not produce any vibrations perceptible to the vehicle and likely to impair the vehicle's normal operations.

1.2.2. The chassis dynamometer may have one roller or two rollers in the cases of three-wheel vehicles with two front wheels and quadricycles. In such cases, the front roller shall drive, directly or indirectly, the inertial masses and the power-absorption device.

1.2.3. It shall be possible to measure and read the indicated load to an accuracy of ± 5 percent.

1.2.4. In the case of a dynamometer with a fixed load curve, the accuracy of the load setting at 80 km/h or of the load setting at the reference vehicle speeds (30 km/h, respectively

Status: Point in time view as at 16/12/2013.

Changes to legislation: There are currently no known outstanding effects for the Commission Delegated Regulation (EU) No 134/2014. (See end of Document for details)

15 km/h) referred to in point 1.1.3.1. for vehicles that cannot attain 80 km/h, shall be ± 5 percent. In the case of a dynamometer with adjustable load curve, the accuracy of matching dynamometer load to road load shall be ± 5 percent for vehicle speeds > 20 km/h and ± 10 percent for vehicle speeds ≤ 20 km/h. Below this vehicle speed, dynamometer absorption shall be positive.

1.2.5. The total inertia of the rotating parts (including the simulated inertia where applicable) shall be known and shall be within ± 10 kg of the inertia class for the test.

1.2.6. The speed of the vehicle shall be measured by the speed of rotation of the roller (the front roller in the case of a two-roller dynamometer). It shall be measured with an accuracy of ± 1 km/h at vehicle speeds over 10 km/h. The distance actually driven by the vehicle shall be measured by the movement of rotation of the roller (the front roller in the case of a two-roller dynamometer).

2. **Dynamometer calibration procedure**

2.1. Introduction

This section describes the method to be used to determine the load absorbed by a dynamometer brake. The load absorbed comprises the load absorbed by frictional effects and the load absorbed by the power-absorption device. The dynamometer is brought into operation beyond the range of test speeds. The device used for starting up the dynamometer is then disconnected; the rotational speed of the driven roller decreases. The kinetic energy of the rollers is dissipated by the power-absorption unit and by the frictional effects. This method disregards variations in the roller's internal frictional effects caused by rollers with or without the vehicle. The frictional effects of the rear roller shall be disregarded when the roller is free.

2.2. Calibration of the load indicator at 80 km/h or of the load indicator referred to in point 1.1.3.1. for vehicles that cannot attain 80 km/h.

The following procedure shall be used for calibration of the load indicator to 80 km/h or the applicable load indicator referred to in point 1.1.3.1. for vehicles that cannot attain 80 km/h, as a function of the load absorbed (see also Figure Ap3-1):

2.2.1. Measure the rotational speed of the roller if this has not already been done. A fifth wheel, a revolution counter or some other method may be used.

2.2.2. Place the vehicle on the dynamometer or devise some other method for starting up the dynamometer.

2.2.3. Use the flywheel or any other system of inertia simulation for the particular inertia class to be used.

Figure Ap3-1

Status: Point in time view as at 16/12/2013.

Changes to legislation: There are currently no known outstanding effects for the Commission Delegated Regulation (EU) No 134/2014. (See end of Document for details)

Power absorbed by the chassis dynamometer

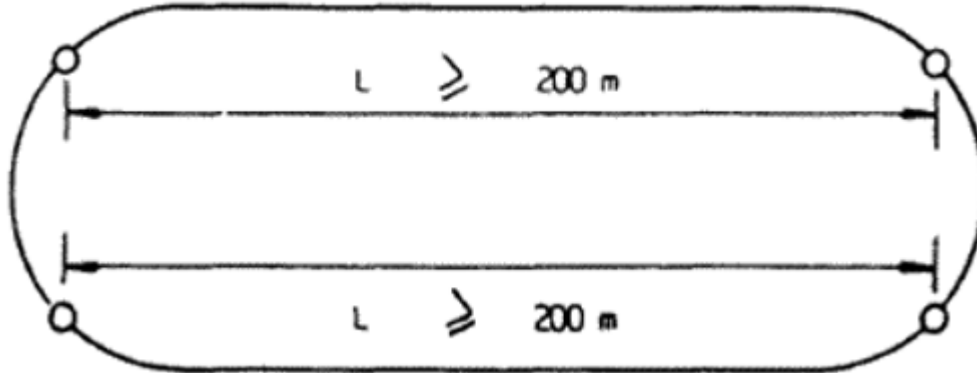

- 2.2.4. Bring the dynamometer to a vehicle speed of 80 km/h or to the reference vehicle speed referred to in point 1.1.3.1. for vehicles that cannot attain 80 km/h.
- 2.2.5. Note the load indicated F_i (N).
- 2.2.6. Bring the dynamometer to a speed of 90 km/h or to the respective reference vehicle speed referred to in to in point 1.1.3.1. plus 5 km/h for vehicles that cannot attain 80 km/h
- 2.2.7. Disconnect the device used to start up the dynamometer.
- 2.2.8. Note the time taken by the dynamometer to pass from a vehicle speed of 85 to 75 km/h, or for vehicles that cannot attain 80 km/h referred to in Table Ap8-1 of Appendix 8, note the time between $v_j + 5$ km/h to $v_j - 5$ km/h.
- 2.2.9. Set the power-absorption device at a different level.
- 2.2.10. The requirements of points 2.2.4. to 2.2.9. shall be repeated sufficiently often to cover the range of loads used.
- 2.2.11. Calculate the load absorbed using the formula:

Equation Ap3-2:

$$F = \frac{m_i \times \Delta v}{\Delta t}$$

where:

- | | |
|------------|--|
| F | = load absorbed (N); |
| m_i | = equivalent inertia in kg (excluding the inertial effects of the free rear roller); |
| Δv | = vehicle speed deviation in m/s (10 km/h = 2,775 m/s); |
| Δt | = time taken by the roller to pass from 85 km/h to 75 km/h, or for vehicles that cannot attain 80 km/h from 35 – 25 km/h, respectively from 20 – 10 km/h, referred to in Table Ap 7-1 of Appendix 7. |

- 2.2.12. Figure Ap3-2 shows the load indicated at 80 km/h in terms of load absorbed at 80 km/h.
- Figure Ap3-2*

Status: Point in time view as at 16/12/2013.

Changes to legislation: There are currently no known outstanding effects for the Commission Delegated Regulation (EU) No 134/2014. (See end of Document for details)

Load indicated at 80 km/h in terms of load absorbed at 80 km/h

The shaded part is called 'test area'

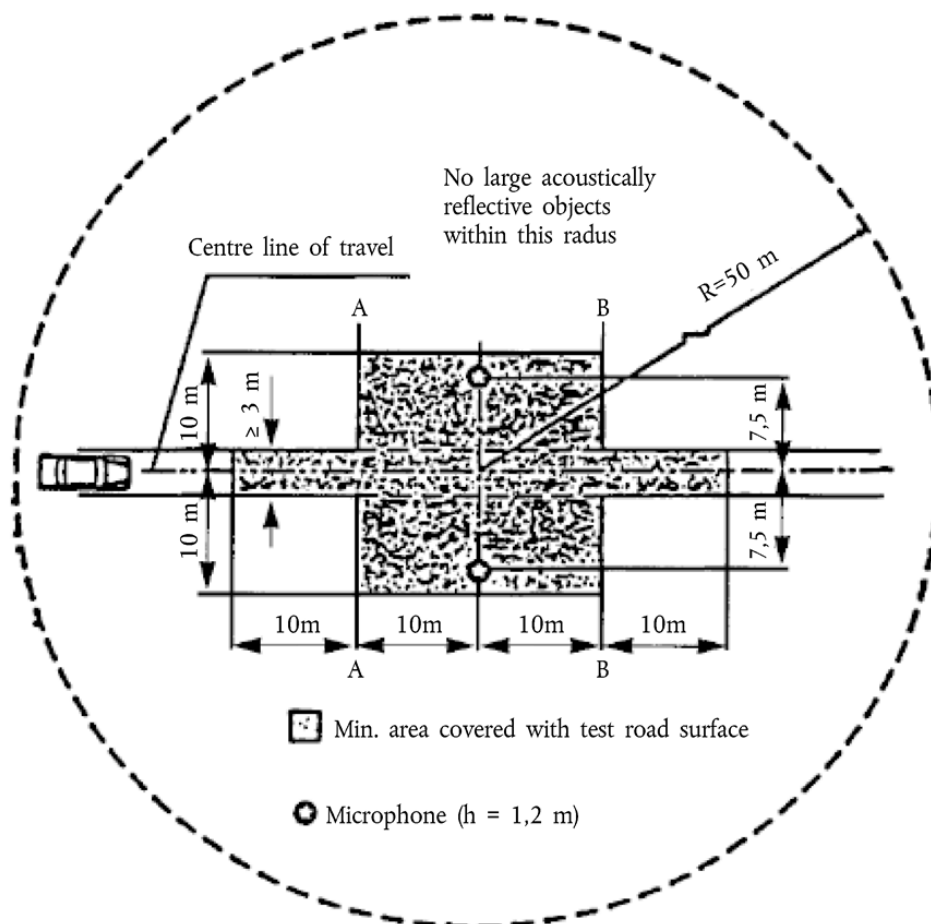

2.2.13. The requirements laid down in points 2.2.3. to 2.2.12. shall be repeated for all inertia classes to be used.

2.3. Calibration of the load indicator at other speeds

The procedures described in point 2.2. shall be repeated as often as necessary for the chosen vehicle speeds.

2.4. Calibration of force or torque

The same procedure shall be used for force or torque calibration.

3. Verification of the load curve

3.1. Procedure

The load-absorption curve of the dynamometer from a reference setting at a speed of 80 km/h or for vehicles that cannot attain 80 km/h at the respective reference vehicle speeds referred to in point 1.1.3.1., shall be verified as follows:

Status: Point in time view as at 16/12/2013.

Changes to legislation: There are currently no known outstanding effects for the Commission Delegated Regulation (EU) No 134/2014. (See end of Document for details)

- 3.1.1. Place the vehicle on the dynamometer or devise some other method for starting up the dynamometer.
- 3.1.2. Adjust the dynamometer to the absorbed load (F_{80}) at 80 km/h, or for vehicles that cannot attain 80 km/h to the absorbed load F_{v_j} at the respective target vehicle speed v_j referred to in point 1.1.3.1.
- 3.1.3. Note the load absorbed at 120, 100, 80, 60, 40 and 20 km/h or for vehicles that cannot attain 80 km/h absorbed at the target vehicles speeds v_j referred to in point 1.1.3.1.
- 3.1.4. Draw the curve $F(v)$ and verify that it corresponds to the requirements of point 1.1.3.1.
- 3.1.5. Repeat the procedure set out in points 3.1.1. to 3.1.4. for other values of F_{80} and for other values of inertia.

4 Verification of simulated inertia

4.1. Object

The method described in this Appendix makes it possible to check that the simulated total inertia of the dynamometer is carried out satisfactorily in the running phase of the operating cycle. The manufacturer of the chassis dynamometer shall specify a method for verifying the specifications according to point 4.3.

4.2. Principle

4.2.1. Drawing-up working equations

Since the dynamometer is subjected to variations in the rotating speed of the roller(s), the force at the surface of the roller(s) can be expressed by:

Equation Ap3-3:

$$F = I \times \gamma = I_M \times \gamma + F_1$$

where:

- F is the force at the surface of the roller(s) in N;
- I is the total inertia of the dynamometer (equivalent inertia of the vehicle);
- I_M is the inertia of the mechanical masses of the dynamometer;
- γ is the tangential acceleration at roller surface;
- F_1 is the inertia force.

Note: An explanation of this formula with reference to dynamometers with mechanically simulated inertia is appended.

Thus, total inertia is expressed as follows:

Equation Ap3-4:

$$I = I_m + F_1 / \gamma$$

where:

- I_m can be calculated or measured by traditional methods;
- F_1 can be measured on the dynamometer;
- γ can be calculated from the peripheral speed of the rollers.

The total inertia (I) will be determined during an acceleration or deceleration test with values no lower than those obtained on an operating cycle.

4.2.2. Specification for the calculation of total inertia

The test and calculation methods shall make it possible to determine the total inertia I with a relative error ($\Delta I/I$) of less than ± 2 percent.

4.3. Specification

4.3.1. The mass of the simulated total inertia I shall remain the same as the theoretical value of the equivalent inertia (see Appendix 5) within the following limits:

4.3.1.1. ± 5 percent of the theoretical value for each instantaneous value;

4.3.1.2. ± 2 percent of the theoretical value for the average value calculated for each sequence of the cycle.

The limit specified in point 4.3.1.1. is brought to ± 50 percent for one second when starting and, for vehicles with manual transmission, for two seconds during gear changes.

4.4. Verification procedure

4.4.1. Verification is carried out during each test throughout the test cycles defined in Appendix 6 of Annex II.

4.4.2. However, if the requirements laid down in point 4.3. are met, with instantaneous accelerations which are at least three times greater or smaller than the values obtained in the sequences of the theoretical cycle, the verification described in point 4.4.1. will not be necessary.

Status: Point in time view as at 16/12/2013.

Changes to legislation: There are currently no known outstanding effects for the Commission Delegated Regulation (EU) No 134/2014. (See end of Document for details)

Appendix 4

Exhaust dilution system

1. System specification

1.1. System overview

A full-flow exhaust dilution system shall be used. This requires that the vehicle exhaust be continuously diluted with ambient air under controlled conditions. The total volume of the mixture of exhaust and dilution air shall be measured and a continuously proportional sample of the volume shall be collected for analysis. The quantities of pollutants are determined from the sample concentrations, corrected for the pollutant content of the ambient air and the totalised flow over the test period. The exhaust dilution system shall consist of a transfer tube, a mixing chamber and dilution tunnel, a dilution air conditioning, a suction device and a flow measurement device. Sampling probes shall be fitted in the dilution tunnel as specified in Appendices 3, 4 and 5. The mixing chamber described in this point shall be a vessel, such as those illustrated in Figures Ap4-1 and Ap4-2, in which vehicle exhaust gases and the dilution air are combined so as to produce a homogeneous mixture at the chamber outlet.

1.2. General requirements

1.2.1. The vehicle exhaust gases shall be diluted with a sufficient amount of ambient air to prevent any water condensation in the sampling and measuring system under any conditions which may occur during a test.

1.2.2. The mixture of air and exhaust gases shall be homogeneous at the point where the sampling probe is located (see point 1.3.3.). The sampling probe shall extract a representative sample of the diluted exhaust gas.

1.2.3. The system shall enable the total volume of the diluted exhaust gases to be measured.

1.2.4. The sampling system shall be gas-tight. The design of the variable dilution sampling system and the materials that go to make it up shall be such that they do not affect the pollutant concentration in the diluted exhaust gases. Should any component in the system (heat exchanger, cyclone separator, blower, etc.) change the concentration of any of the pollutants in the diluted exhaust gases and the fault cannot be corrected, sampling for that pollutant shall be carried out upstream from that component.

1.2.5. All parts of the dilution system that are in contact with raw and diluted exhaust gas shall be designed to minimise deposition or alteration of the particulates or particles. All parts shall be made of electrically conductive materials that do not react with exhaust gas components and shall be electrically grounded to prevent electrostatic effects.

1.2.6. If the vehicle being tested is equipped with an exhaust pipe comprising several branches, the connecting tubes shall be connected as near as possible to the vehicle without adversely affecting its operation.

1.2.7. The variable-dilution system shall be designed so as to enable the exhaust gases to be sampled without appreciably changing the back-pressure at the exhaust pipe outlet.

1.2.8. The connecting tube between the vehicle and dilution system shall be so designed as to minimise heat loss.

1.3. Specific requirements

1.3.1. Connection to vehicle exhaust

The connecting tube between the vehicle exhaust outlets and the dilution system shall be as short as possible and satisfy the following requirements:

- (a) the tube shall be less than 3,6 m long, or less than 6,1 m long if heat insulated. Its internal diameter may not exceed 105 mm;
- (b) it shall not cause the static pressure at the exhaust outlets on the test vehicle to differ by more than $\pm 0,75$ kPa at 50 km/h, or more than $\pm 1,25$ kPa for the whole duration of the test, from the static pressures recorded when nothing is connected to the vehicle exhaust outlets. The pressure shall be measured in the exhaust outlet or in an extension having the same diameter, as near as possible to the end of the pipe. Sampling systems capable of maintaining the static pressure to within $\pm 0,25$ kPa may be used if a written request from a manufacturer to the technical service substantiates the need for the closer tolerance;
- (c) it shall not change the nature of the exhaust gas;
- (d) any elastomeric connectors employed shall be as thermally stable as possible and have minimum exposure to the exhaust gases.

1.3.2. Dilution air conditioning

The dilution air used for the primary dilution of the exhaust in the CVS tunnel shall be passed through a medium capable of reducing particles in the most penetrating particle size of the filter material by $\geq 99,95$ percent, or through a filter of at least class H13 of EN 1822:1998. This represents the specification of High Efficiency Particulate Air (HEPA) filters. The dilution air may be charcoal scrubbed before being passed to the HEPA filter. It is recommended that an additional coarse particle filter is situated before the HEPA filter and after the charcoal scrubber, if used. At the vehicle manufacturer's request, the dilution air may be sampled according to good engineering practice to determine the tunnel contribution to background particulate mass levels, which can then be subtracted from the values measured in the diluted exhaust.

1.3.3. Dilution tunnel

Provision shall be made for the vehicle exhaust gases and the dilution air to be mixed. A mixing orifice may be used. In order to minimise the effects on the conditions at the exhaust outlet and to limit the drop in pressure inside the dilution-air conditioning device, if any, the pressure at the mixing point shall not differ by more than $\pm 0,25$ kPa from atmospheric pressure. The homogeneity of the mixture in any cross-section at the location of the sampling probe shall not vary by more than ± 2 percent from the average of the values obtained for at least five points located at equal intervals on the diameter of the gas stream. For particulate and particle emissions sampling, a dilution tunnel shall be used which:

- (a) shall consist of a straight tube of electrically-conductive material, which shall be earthed;
- (b) shall be small enough in diameter to cause turbulent flow (Reynolds number $\geq 4\ 000$) and of sufficient length to cause complete mixing of the exhaust and dilution air;
- (c) shall be at least 200 mm in diameter;
- (d) may be insulated.

1.3.4. Suction device

Status: Point in time view as at 16/12/2013.

Changes to legislation: There are currently no known outstanding effects for the Commission Delegated Regulation (EU) No 134/2014. (See end of Document for details)

This device may have a range of fixed speeds to ensure sufficient flow to prevent any water condensation. This result is generally obtained if the flow is either:

- (a) twice the maximum flow of exhaust gas produced by accelerations of the driving cycle; or
- (b) sufficient to ensure that the CO₂ concentration in the dilute exhaust sample bag is less than 3 percent by volume for petrol and diesel, less than 2,2 percent by volume for LPG and less than 1,5 percent by volume for NG/biomethane.

1.3.5. Volume measurement in the primary dilution system

The method for measuring total dilute exhaust volume incorporated in the constant volume sampler shall be such that measurement is accurate to ± 2 percent under all operating conditions. If the device cannot compensate for variations in the temperature of the mixture of exhaust gases and dilution air at the measuring point, a heat exchanger shall be used to maintain the temperature to within ± 6 K of the specified operating temperature. If necessary, some form of protection for the volume measuring device may be used, e.g. a cyclone separator, bulk stream filter, etc. A temperature sensor shall be installed immediately before the volume measuring device. This sensor shall have an accuracy and a precision of ± 1 K and a response time of 0,1 s at 62 percent of a given temperature variation (value measured in silicone oil). The difference from atmospheric pressure shall be measured upstream and, if necessary, downstream from the volume measuring device. The pressure measurements shall have a precision and an accuracy of $\pm 0,4$ kPa during the test.

1.4. Recommended system descriptions

Figure Ap 4-1 and Figure Ap 4-2 are schematic drawings of two types of recommended exhaust dilution systems that meet the requirements of this Annex. Since various configurations can produce accurate results, exact conformity with these figures is not essential. Additional components such as instruments, valves, solenoids and switches may be used to provide additional information and coordinate the functions of the component system.

1.4.1. Full-flow dilution system with positive displacement pump

Figure Ap4-1

Status: Point in time view as at 16/12/2013.

Changes to legislation: There are currently no known outstanding effects for the Commission Delegated Regulation (EU) No 134/2014. (See end of Document for details)

Positive displacement pump dilution system

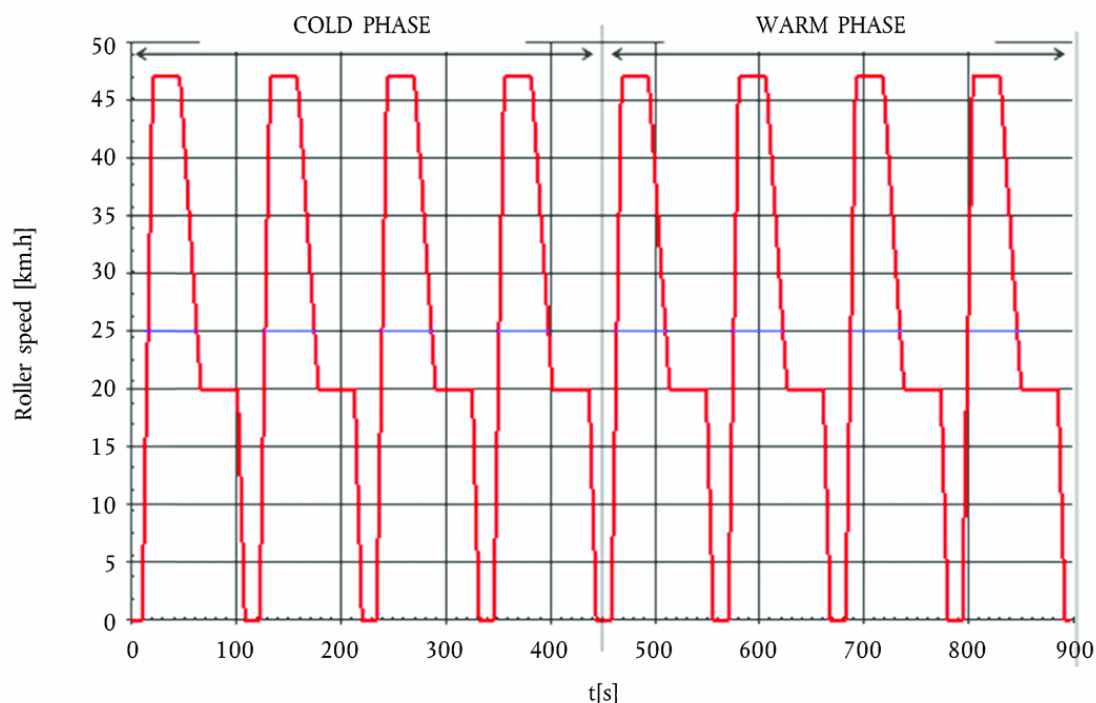

The positive displacement pump (PDP) full-flow dilution system satisfies the requirements of this Annex by metering the flow of gas through the pump at constant temperature and pressure. The total volume is measured by counting the revolutions of the calibrated positive displacement pump. The proportional sample is achieved by sampling with pump, flow meter and flow control valve at a constant flow rate. The collecting equipment consists of:

- 1.4.1.1. A filter (refer to DAF in Figure Ap 4-1) for the dilution air shall be installed, which can be preheated if necessary. This filter shall consist of the following filters in sequence: an optional activated charcoal filter (inlet side) and a high efficiency particulate air (HEPA) filter (outlet side). It is recommended that an additional coarse particle filter is situated before the HEPA filter and after the charcoal filter, if used. The purpose of the charcoal filter is to reduce and stabilise the hydrocarbon concentrations of ambient emissions in the dilution air;
- 1.4.1.2. A transfer tube (TT) by which vehicle exhaust is admitted into a dilution tunnel (DT) in which the exhaust gas and dilution air are mixed homogeneously;
- 1.4.1.3. The positive displacement pump (PDP), producing a constant-volume flow of the air/exhaust-gas mixture. The PDP revolutions, together with associated temperature and pressure measurement, are used to determine the flow rate;
- 1.4.1.4. A heat exchanger (HE) of a capacity sufficient to ensure that throughout the test the temperature of the air/exhaust-gas mixture measured at a point immediately upstream of the positive displacement pump is within 6 K of the average operating temperature during the test. This device shall not affect the pollutant concentrations of diluted gases taken off afterwards for analysis.

Status: Point in time view as at 16/12/2013.

Changes to legislation: There are currently no known outstanding effects for the Commission Delegated Regulation (EU) No 134/2014. (See end of Document for details)

1.4.1.5. A mixing chamber (MC) in which exhaust gas and air are mixed homogeneously and which may be located close to the vehicle so that the length of the transfer tube (TT) is minimised.

1.4.2. Full-flow dilution system with critical-flow venturi

Figure Ap4-2

Critical-flow venturi dilution system

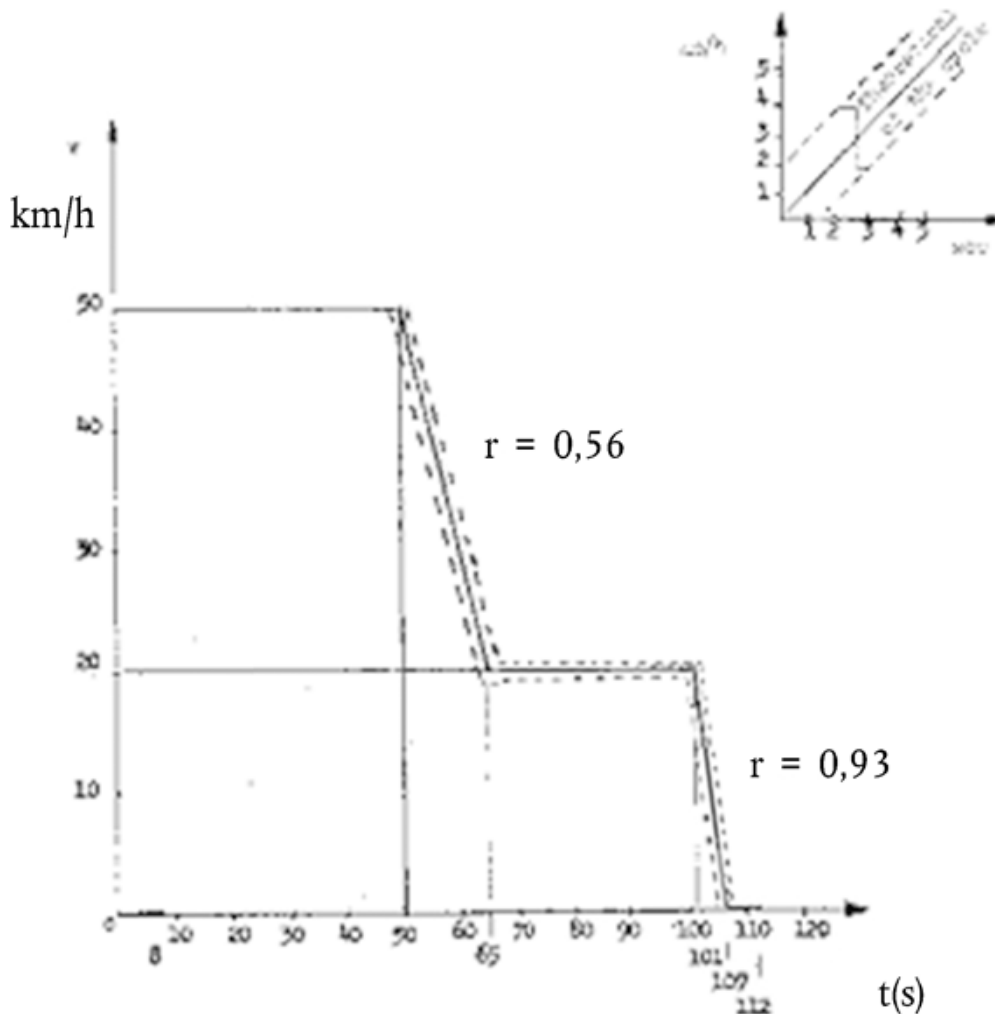

The use of a critical-flow venturi (CFV) for the full-flow dilution system is based on the principles of flow mechanics for critical flow. The variable mixture flow rate of dilution and exhaust gas is maintained at sonic velocity which is directly proportional to the square root of the gas temperature. Flow is continually monitored, computed and integrated throughout the test. The use of an additional critical-flow sampling venturi ensures the proportionality of the gas samples taken from the dilution tunnel. As pressure and temperature are both equal at the two venturi inlets, the volume of the gas flow diverted for sampling is proportional to the total volume of diluted exhaust-gas mixture produced, and thus the requirements of this Annex are met. The collecting equipment consists of:

Status: Point in time view as at 16/12/2013.

Changes to legislation: There are currently no known outstanding effects for the Commission Delegated Regulation (EU) No 134/2014. (See end of Document for details)

- 1.4.2.1. A filter (DAF) for the dilution air which can be preheated if necessary. This filter shall consist of the following filters in sequence: an optional activated charcoal filter (inlet side) and a high efficiency particulate air (HEPA) filter (outlet side). It is recommended that an additional coarse particle filter is situated before the HEPA filter and after the charcoal filter, if used. The purpose of the charcoal filter is to reduce and stabilise the hydrocarbon concentrations of ambient emissions in the dilution air;
- 1.4.2.2. A mixing chamber (MC) in which exhaust gas and air are mixed homogeneously and which may be located close to the vehicle so that the length of the transfer tube (TT) is minimised;
- 1.4.2.3. A dilution tunnel (DT) from which particulates and particles are sampled;
- 1.4.2.4. Some form of protection for the measurement system may be used, e.g. a cyclone separator, bulk stream filter, etc.;
- 1.4.2.5. A measuring critical-flow venturi tube (CFV) to measure the flow volume of the diluted exhaust gas;
- 1.4.2.6. A blower (BL) of sufficient capacity to handle the total volume of diluted exhaust gas.

2. **CVS calibration procedure**

2.1. General requirements

The CVS system shall be calibrated by using an accurate flow-meter and a restricting device. The flow through the system shall be measured at various pressure readings and the control parameters of the system measured and related to the flows. The flow-meter shall be dynamic and suitable for the high flow-rate encountered in CVS testing. The device shall be of certified accuracy traceable to an approved national or international standard.

- 2.1.1. Various types of flow-meter may be used, e.g. calibrated venturi, laminar flow-meter, calibrated turbine-meter, provided that they are dynamic measurement systems and can meet the requirements of point 1.3.5. of this Appendix.
- 2.1.2. The following points give details of methods of calibrating PDP and CFV units, using a laminar flow-meter which gives the required accuracy, together with a statistical check on the calibration validity.

2.2. Calibration of the positive displacement pump (PDP)

- 2.2.1. The following calibration procedure outlines the equipment, the test configuration and the various parameters that are measured to establish the flow-rate of the CVS pump. All the parameters relating to the pump are simultaneously measured with the parameters relating to the flow-meter which is connected in series with the pump. The calculated flow rate (given in m³/min at pump inlet, absolute pressure and temperature) can then be plotted against a correlation function that is the value of a specific combination of pump parameters. The linear equation that relates the pump flow and the correlation function is then determined. If a CVS has a multiple speed drive, a calibration shall be performed for each range used.
- 2.2.2. This calibration procedure is based on the measurement of the absolute values of the pump and flow-meter parameters that relate to the flow rate at each point. Three conditions shall be maintained to ensure the accuracy and integrity of the calibration curve:

Status: Point in time view as at 16/12/2013.

Changes to legislation: There are currently no known outstanding effects for the Commission Delegated Regulation (EU) No 134/2014. (See end of Document for details)

- 2.2.2.1. The pump pressures shall be measured at tappings on the pump rather than at the external piping on the pump inlet and outlet. Pressure taps that are mounted at the top centre and bottom centre of the pump drive head plate are exposed to the actual pump cavity pressures and therefore reflect the absolute pressure differentials;
- 2.2.2.2. Temperature stability shall be maintained during the calibration. The laminar flow-meter is sensitive to inlet temperature oscillations which cause the data points to be scattered. Gradual changes of ± 1 K in temperature are acceptable as long as they occur over a period of several minutes;
- 2.2.2.3. All connections between the flow-meter and the CVS pump shall be free of any leakage.
- 2.2.3. During an exhaust emission test, the measurement of these same pump parameters enables the user to calculate the flow rate from the calibration equation.
- 2.2.4. Figure Ap 4-3 of this Appendix shows one possible test set-up. Variations are permissible, provided that the technical service approves them as being of comparable accuracy. If the set-up shown in Figure Ap 4-3 is used, the following data shall be found within the limits of precision given:
- Barometric pressure (corrected) (P_b) $\pm 0,03$ kPa
 - Ambient temperature (T) $\pm 0,2$ K
 - Air temperature at LFE (ETI) $\pm 0,15$ K
 - Pressure depression upstream of LFE (EPI) $\pm 0,01$ kPa
 - Pressure drop across the LFE matrix (EDP) $\pm 0,0015$ kPa
 - Air temperature at CVS pump inlet (PTI) $\pm 0,2$ K
 - Air temperature at CVS pump outlet (PTO) $\pm 0,2$ K
 - Pressure depression at CVS pump inlet (PPI) $\pm 0,22$ kPa
 - Pressure head at CVS pump outlet (PPO) $\pm 0,22$ kPa
 - Pump revolutions during test period (n) ± 1 min⁻¹
 - Elapsed time for period (minimum 250 s) (t) $\pm 0,1$ s

Figure Ap4-3

PDP calibration configuration

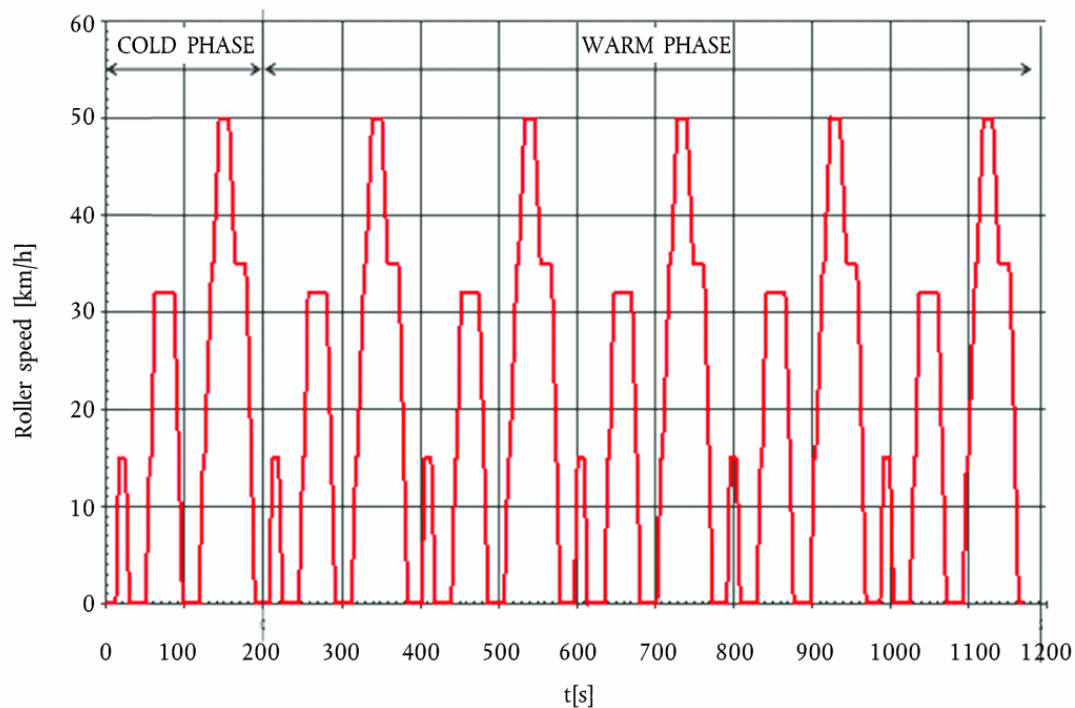

- 2.2.5. After the system has been connected as shown in Figure Ap 4-3, set the variable restrictor in the wide-open position and run the CVS pump for 20 minutes before starting the calibration.
- 2.2.6. Reset the restrictor valve to a more restricted condition in an increment of pump inlet depression (about 1 kPa) that will yield a minimum of six data points for the total calibration. Allow the system to stabilise for three minutes and repeat the data acquisition.
- 2.2.7. The air flow rate (Q_s) at each test point is calculated in standard m^3/min from the flow-meter data using the manufacturer's prescribed method.
- 2.2.8. The air flow-rate is then converted to pump flow (V_0) in m^3/rev at absolute pump inlet temperature and pressure.

Equation Ap 4-1:

$$V_0 = \frac{Q_s}{n} \times \frac{T_p}{273,2} \times \frac{101,33}{P_p}$$

where:

- V_0 = pump flow rate at T_p and P_p (m^3/rev);
 Q_s = air flow at 101,33 kPa and 273,2 K (m^3/min);
 T_p = pump inlet temperature (K);
 P_p = absolute pump inlet pressure (kPa);
 n = pump speed (min^{-1}).

- 2.2.9. To compensate for the interaction of pump speed pressure variations at the pump and the pump slip rate, the correlation function (x_0) between the pump speed (n), the

Status: Point in time view as at 16/12/2013.

Changes to legislation: There are currently no known outstanding effects for the Commission Delegated Regulation (EU) No 134/2014. (See end of Document for details)

pressure differential from pump inlet to pump outlet, and the absolute pump outlet pressure is calculated as follows:

Equation Ap 4-2:

$$x_0 = \frac{1}{n} \sqrt{\frac{\Delta P_p}{P_e}}$$

where:

x_0 = correlation function;
 ΔP_p = pressure differential from pump inlet to pump outlet (kPa);
 P_e = absolute outlet pressure (PPO + P_b) (kPa).

2.2.9.1. A linear least-square fit is performed to generate the calibration equations which have the formula:

Equation Ap 4-3:

$$V_0 = D_0 - M(x_0)$$

$$n = A - B(\Delta P_p)$$

D_0 , M , A and B are the slope-intercept constants describing the lines.

2.2.10. A CVS system that has multiple speeds shall be calibrated on each speed used. The calibration curves generated for the ranges shall be approximately parallel and the intercept values (D_0) shall increase as the pump flow range decreases.

2.2.11 If the calibration has been performed carefully, the calculated values from the equation will be within 0.5 percent of the measured value of V_0 . Values of M will vary from one pump to another. Calibration is performed at pump start-up and after major maintenance.

2.3. Calibration of the critical-flow venturi (CFV)

2.3.1. Calibration of the CFV is based on the flow equation for a critical-flow venturi:

Equation Ap 4-4:

$$Q_s = \frac{K_v P}{\sqrt{T}}$$

where:

Q_s = flow;
 K_v = calibration coefficient;
 P = absolute pressure (kPa);
 T = absolute temperature (K).

Gas flow is a function of inlet pressure and temperature. The calibration procedure described in points 2.3.2. to 2.3.7. shall establish the value of the calibration coefficient at measured values of pressure, temperature and air flow.

2.3.2. The manufacturer's recommended procedure shall be followed for calibrating electronic portions of the CFV.

2.3.3. Measurements for flow calibration of the critical-flow venturi are required and the following data shall be found within the limits of precision given:

Barometric pressure (corrected) (P_b) $\pm 0,03$ kPa

LFE air temperature, flow-meter (ETI) $\pm 0,15$ K

Pressure depression upstream of LFE (EPI) $\pm 0,01$ kPa

Status: Point in time view as at 16/12/2013.

Changes to legislation: There are currently no known outstanding effects for the Commission Delegated Regulation (EU) No 134/2014. (See end of Document for details)

Pressure drop across (EDP) LFE matrix $\pm 0,0015$ kPa

Air flow (Q_s) $\pm 0,5$ percent

CFV inlet depression (PPI) $\pm 0,02$ kPa

Temperature at venturi inlet (T_v) $\pm 0,2$ K.

- 2.3.4. The equipment shall be set up as shown in Figure Ap 4-4 and checked for leaks. Any leaks between the flow-measuring device and the critical-flow venturi will seriously affect the accuracy of the calibration.

Figure Ap4-4

CFV calibration configuration

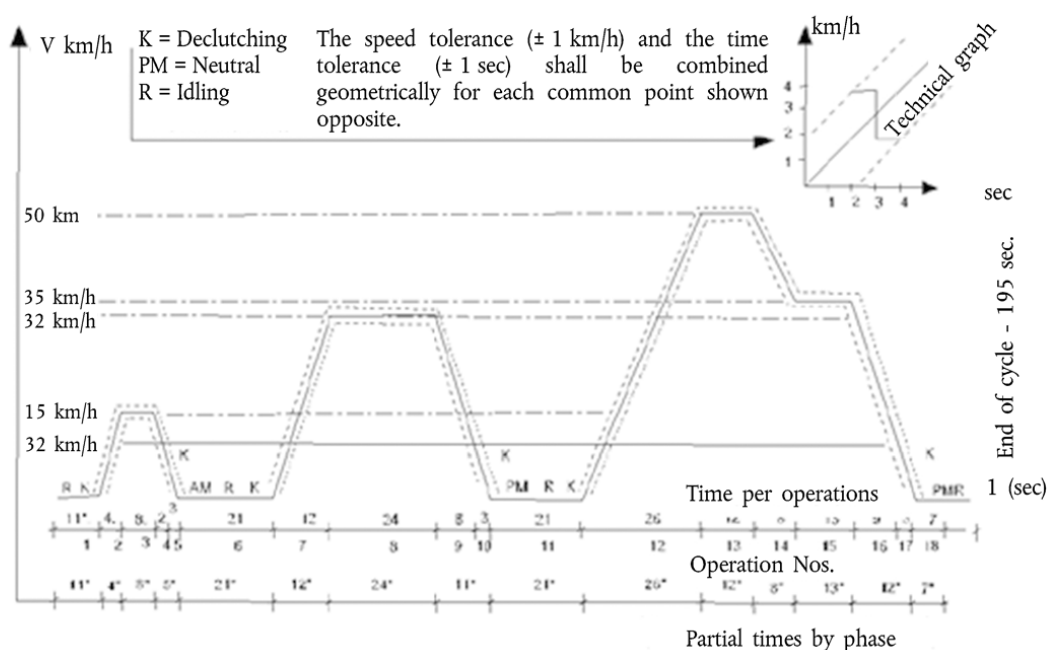

- 2.3.5. The variable-flow restrictor shall be set to the open position, the blower shall be started and the system stabilised. Data from all instruments shall be recorded.
- 2.3.6. The flow restrictor shall be varied and at least eight readings shall be taken across the critical flow range of the venturi.
- 2.3.7. The data recorded during the calibration shall be used in the following calculations. The air flow-rate (Q_s) at each test point is calculated from the flow-meter data using the manufacturer's prescribed method. Calculate values of the calibration coefficient (K_v) for each test point:

Equation Ap 4-5:

$$K_v = \frac{Q_s \sqrt{T_v}}{P_v}$$

where:

- Q_s = flow-rate in m^3/min at 273,2 K and 101,3 kPa;
- T_v = temperature at the venturi inlet (K);
- P_v = absolute pressure at the venturi inlet (kPa).

Status: Point in time view as at 16/12/2013.

Changes to legislation: There are currently no known outstanding effects for the Commission Delegated Regulation (EU) No 134/2014. (See end of Document for details)

Plot K_v as a function of venturi inlet pressure. For sonic flow, K_v will have a relatively constant value. As pressure decreases (vacuum increases), the venturi becomes unchoked and K_v decreases. The resultant K_v changes are not permissible. For a minimum of eight points in the critical region, calculate an average K_v and the standard deviation. If the standard deviation exceeds 0,3 percent of the average K_v , take corrective action.

3. System verification procedure

3.1. General requirements

The total accuracy of the CVS sampling system and analytical system shall be determined by introducing a known mass of a pollutant gas into the system while it is being operated as if during a normal test and then analysing and calculating the pollutant mass according to the formula in point 4, except that the density of propane shall be taken as 1,967 grams per litre at standard conditions. The two techniques described in points 3.2. and 3.3. are known to give sufficient accuracy. The maximum permissible deviation between the quantity of gas introduced and the quantity of gas measured is 5 percent.

3.2. CFO method

3.2.1. Metering a constant flow of pure gas (CO or C₃H₈) using a critical-flow orifice device

3.2.2. A known quantity of pure gas (CO or C₃H₈) is fed into the CVS system through the calibrated critical orifice. If the inlet pressure is high enough, the flow-rate (q), which is adjusted by means of the critical-flow orifice, is independent of orifice outlet pressure (critical flow). If deviations exceeding 5 percent occur, the cause of the malfunction shall be determined and corrected. The CVS system is operated as in an exhaust emission test for about five to ten minutes. The gas collected in the sampling bag is analysed by the usual equipment and the results compared to the concentration of the gas samples which was known beforehand.

3.3. Gravimetric method

3.3.1. Metering a limited quantity of pure gas (CO or C₃H₈) by means of a gravimetric technique

3.3.2. The following gravimetric procedure may be used to verify the CVS system. The weight of a small cylinder filled with either carbon monoxide or propane is determined with a precision of $\pm 0,01$ g. For about five to ten minutes, the CVS system is operated as in a normal exhaust emission test, while CO or propane is injected into the system. The quantity of pure gas involved is determined by means of differential weighing. The gas accumulated in the bag is analysed using the equipment normally used for exhaust-gas analysis. The results are then compared to the concentration figures computed previously.

Status: Point in time view as at 16/12/2013.

Changes to legislation: There are currently no known outstanding effects for the Commission Delegated Regulation (EU) No 134/2014. (See end of Document for details)

Appendix 5

Classification of equivalent inertia mass and running resistance

1. The chassis dynamometer can be set using the running resistance table instead of the running resistance force obtained by the coast-down methods set out in Appendices 7 or 8. In this table method, the chassis dynamometer shall be set by the reference mass regardless of particular L-category vehicle characteristics.
2. The flywheel equivalent inertia mass m_{ref} shall be the equivalent inertia mass m_i specified in point 4.5.6.1.2. The chassis dynamometer shall be set by the rolling resistance of front wheel 'a' and the aerodynamic drag coefficient 'b' specified in the following table.

Table Ap5-1

Classification of equivalent inertia mass and running resistance used for L-category vehicles

Reference mass m_{ref} (kg)	Equivalent inertia mass m_i (kg)	Rolling resistance of front wheel a(N)	Aero drag coefficient b ($N / (km / h)^2$)
$0 < m_{ref} \leq 25$	20	1,8	0,0203
$25 < m_{ref} \leq 35$	30	2,6	0,0205
$35 < m_{ref} \leq 45$	40	3,5	0,0206
$45 < m_{ref} \leq 55$	50	4,4	0,0208
$55 < m_{ref} \leq 65$	60	5,3	0,0209
$65 < m_{ref} \leq 75$	70	6,8	0,0211
$75 < m_{ref} \leq 85$	80	7,0	0,0212
$85 < m_{ref} \leq 95$	90	7,9	0,0214
$95 < m_{ref} \leq 105$	100	8,8	0,0215
$105 < m_{ref} \leq 115$	110	9,7	0,0217
$115 < m_{ref} \leq 125$	120	10,6	0,0218
$125 < m_{ref} \leq 135$	130	11,4	0,022
$135 < m_{ref} \leq 145$	140	12,3	0,0221
$145 < m_{ref} \leq 155$	150	13,2	0,0223
$155 < m_{ref} \leq 165$	160	14,1	0,0224
$165 < m_{ref} \leq 175$	170	15,0	0,0226
$175 < m_{ref} \leq 185$	180	15,8	0,0227

a The value shall be rounded to one decimal place.

b The value shall be rounded to four decimal places.

Status: Point in time view as at 16/12/2013.

Changes to legislation: There are currently no known outstanding effects for the Commission Delegated Regulation (EU) No 134/2014. (See end of Document for details)

Table Ap5-1

Classification of equivalent inertia mass and running resistance used for L-category vehicles

$185 < m_{ref} \leq 195$	190	16,7	0,0229
$195 < m_{ref} \leq 205$	200	17,6	0,023
$205 < m_{ref} \leq 215$	210	18,5	0,0232
$215 < m_{ref} \leq 225$	220	19,4	0,0233
$225 < m_{ref} \leq 235$	230	20,2	0,0235
$235 < m_{ref} \leq 245$	240	21,1	0,0236
$245 < m_{ref} \leq 255$	250	22,0	0,0238
$255 < m_{ref} \leq 265$	260	22,9	0,0239
$265 < m_{ref} \leq 275$	270	23,8	0,0241
$275 < m_{ref} \leq 285$	280	24,6	0,0242
$285 < m_{ref} \leq 295$	290	25,5	0,0244
$295 < m_{ref} \leq 305$	300	26,4	0,0245
$305 < m_{ref} \leq 315$	310	27,3	0,0247
$315 < m_{ref} \leq 325$	320	28,2	0,0248
$325 < m_{ref} \leq 335$	330	29,0	0,025
$335 < m_{ref} \leq 345$	340	29,9	0,0251
$345 < m_{ref} \leq 355$	350	30,8	0,0253
$355 < m_{ref} \leq 365$	360	31,7	0,0254
$365 < m_{ref} \leq 375$	370	32,6	0,0256
$375 < m_{ref} \leq 385$	380	33,4	0,0257
$385 < m_{ref} \leq 395$	390	34,3	0,0259
$395 < m_{ref} \leq 405$	400	35,2	0,026
$405 < m_{ref} \leq 415$	410	36,1	0,0262
$415 < m_{ref} \leq 425$	420	37,0	0,0263
$425 < m_{ref} \leq 435$	430	37,8	0,0265
$435 < m_{ref} \leq 445$	440	38,7	0,0266
$445 < m_{ref} \leq 455$	450	39,6	0,0268
$455 < m_{ref} \leq 465$	460	40,5	0,0269
$465 < m_{ref} \leq 475$	470	41,4	0,0271

a The value shall be rounded to one decimal place.

b The value shall be rounded to four decimal places.

Status: Point in time view as at 16/12/2013.

Changes to legislation: There are currently no known outstanding effects for the Commission Delegated Regulation (EU) No 134/2014. (See end of Document for details)

Table Ap5-1

Classification of equivalent inertia mass and running resistance used for L-category vehicles

$475 < m_{ref} \leq 485$	480	42,2	0,0272
$485 < m_{ref} \leq 495$	490	43,1	0,0274
$495 < m_{ref} \leq 505$	500	44,0	0,0275
At every 10 kg	At every 10 kg	$a = 0,088 \times m_i$ a	$b = 0,000015 \times m_i + 0,02$ b

a The value shall be rounded to one decimal place.

b The value shall be rounded to four decimal places.

Status: Point in time view as at 16/12/2013.

Changes to legislation: There are currently no known outstanding effects for the Commission Delegated Regulation (EU) No 134/2014. (See end of Document for details)

Appendix 6

Driving cycles for type I tests

(1) UNECE Regulation No 47 (ECE R47)-based test cycle

1. Description of the ECE R47 test cycle

The ECE R47 test cycle to be used on the chassis dynamometer shall be as depicted in the following graph:

Figure Ap6-1

ECE R47-based test cycle

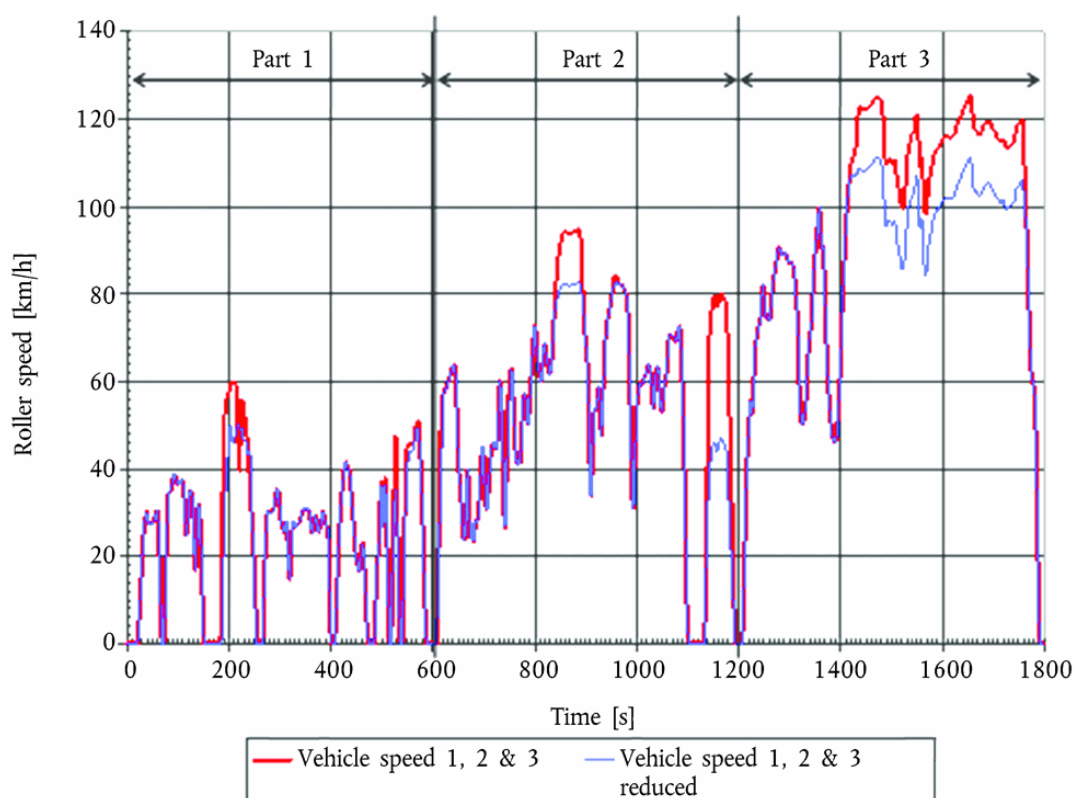

The ECE R47-based test cycle lasts 896 seconds and consists of eight elementary cycles to be carried out without interruption. Each cycle shall comprise of seven driving condition phases (idling, acceleration, steady speed, deceleration, etc.) as set out in points 2 and 3. The truncated vehicle speed trace restricted to maximum 25 km/h is applicable for L1e-A and L1e-B vehicles with a maximum design speed of 25 km/h.

2. The following elementary cycle characteristic in the shape of the dynamometer-roller speed profile versus test time shall be repeated eight times in total. The cold phase means the first 448 s (four cycles) after cold start of the propulsion and warming-up of the engine. The warm or hot phase is the last 448 s (four cycles), when the propulsion is further warming up and finally running at operating temperature.

Status: Point in time view as at 16/12/2013.

Changes to legislation: There are currently no known outstanding effects for the Commission Delegated Regulation (EU) No 134/2014. (See end of Document for details)

TABLE AP6-1

ECE R47 single cycle characteristic vehicle speed profile versus test time

No. of operation	Operation	Acceleration(m/s ²)	Roller speed(km/h)	Duration of operation(s)	Total duration of one cycle(s)
1	Idling	—	—	8	
2	Acceleration	full throttle	0-max		8
3	Constant speed	full throttle	max	57	
4	Deceleration	-0,56	max -20		65
5	Constant speed	—	20	36	101
6	Deceleration	-0,93	20-0	6	107
7	Idling	—	—	5	112

3. ECE R47 test cycle tolerances

The test cycle tolerances indicated in Figure Ap 6-2 for one elementary cycle of the ECE R47 test cycle shall be respected in principle during the whole test cycle.

Figure Ap6-2

ECE R47 based test cycle tolerances

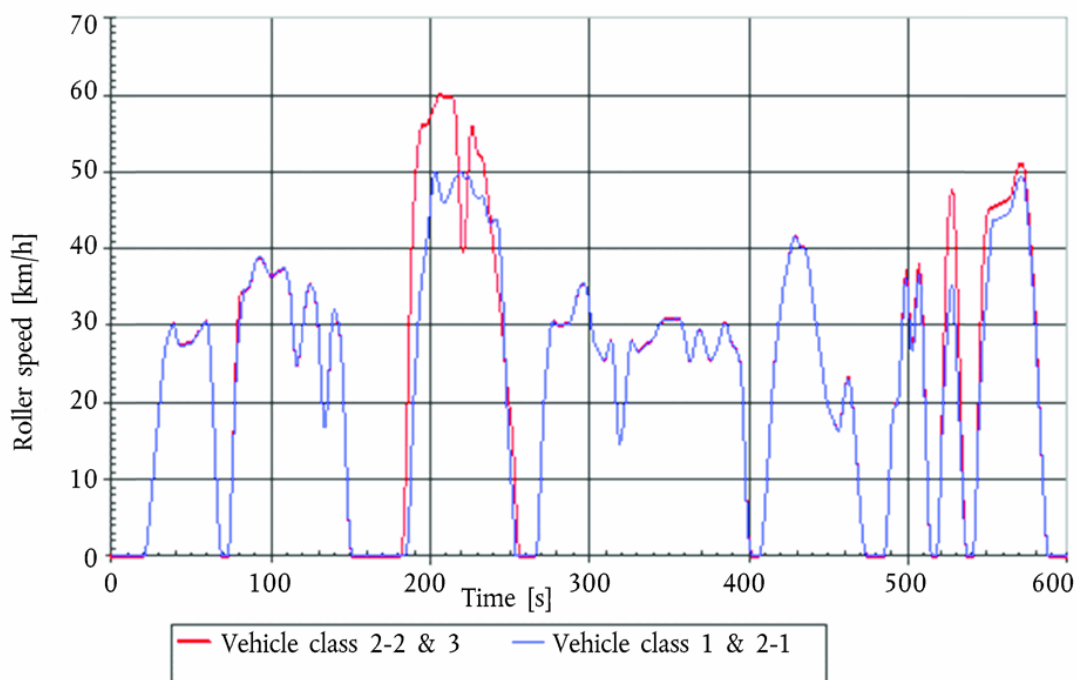

(2) UNECE Regulation No 40 (ECE R40)-based driving cycle

1. Description of the test cycle

Status: Point in time view as at 16/12/2013.

Changes to legislation: There are currently no known outstanding effects for the Commission Delegated Regulation (EU) No 134/2014. (See end of Document for details)

The ECE R40 test cycle to be used on the chassis dynamometer shall be as depicted in the following graph:

Figure Ap6-3

ECE R40-based test cycle

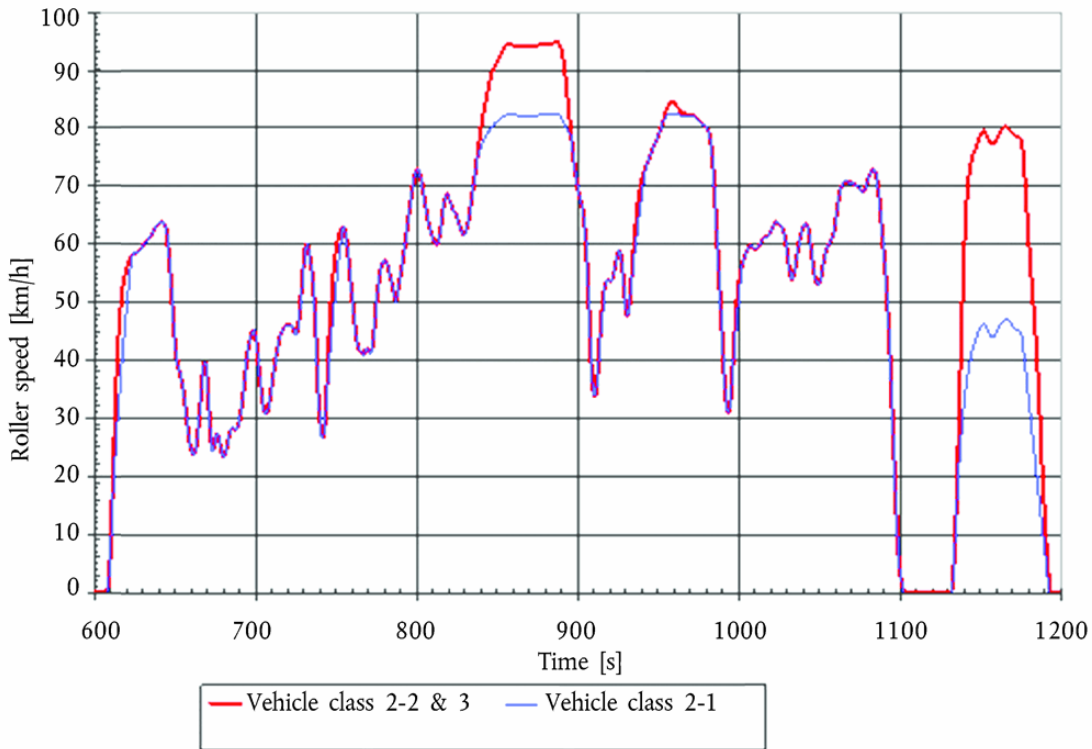

The ECE R40-based test cycle lasts 1 170 seconds and consists of six elementary urban operating cycle cycles to be carried out without interruption. Each elementary urban cycle shall comprise fifteen driving condition phases (idling, acceleration, steady speed, deceleration, etc.) as set out in points 2 and 3.

2. The following cycle characteristic dynamometer-roller speed profile versus test time shall be repeated 6 times in total. The cold phase means the first 195 s (one elementary urban cycle) after cold start of the propulsion and warming up. The warm phase is the last 975 s (five elementary urban cycles), when the propulsion is further warming up and finally running at operating temperature.

2.1

TABLE AP6-2

ECE R40 elementary urban cycle characteristic, vehicle speed profile versus test time

No	Nature of operation	Phase	Acceleration (s ²)	Speed (km/h)	Duration of each		Cumulative time (s)	Gear to be used in the case of a manual-
					Operation (s)	Phase (s)		

a PM = gears in neutral, clutch engaged. K = clutch disengaged.

Status: Point in time view as at 16/12/2013.

Changes to legislation: There are currently no known outstanding effects for the Commission Delegated Regulation (EU) No 134/2014. (See end of Document for details)

								shift gearbox
1	Idling	1	0	0	11	11	11	6 s PM + 5 s K ^a
2	Acceleration	2	1,04	0-15	4	4	15	According to manufacturer's instructions
3	Steady speed	3	0	15	8	8	23	
4	Deceleration	4	-0,69	15-10	2	5	25	
5	Deceleration, clutch disengaged	5	-0,92	10-0	3		28	K ^a
6	Idling	5	0	0	21	21	49	16 s PM + 5 s K ^a
7	Acceleration	6	0,74	0-32	12	12	61	According to manufacturer's instructions
8	Steady speed	7		32	24	24	85	
9	Deceleration	8	-0,75	32-10	8	11	93	
10	Deceleration, clutch disengaged	9	-0,92	10-0	3		96	K ^a
11	Idling	9	0	0	21	21	117	16 s PM + 5 s K ^a
12	Acceleration	10	0,53	0-50	26	26	143	According to manufacturer's instructions
13	Steady speed	11	0	50	12	12	155	
14	Deceleration	12	-0,52	50-35	8	8	163	
15	Steady speed	13	0	35	13	13	176	K ^a
16	Deceleration	14	-0,68	35-10	9		185	
17	Deceleration, clutch disengaged	15	-0,92	10-0	3		188	
18	Idling	15	0	0	7	7	195	7 s PM ^a

a PM = gears in neutral, clutch engaged. K = clutch disengaged.

3. ECE R40 test cycle tolerances

The test cycle tolerances indicated in Figure Ap 6-4 for one elementary urban cycle of the ECE R40 test cycle shall be respected in principle during the whole test cycle.

Figure Ap6-4

Status: Point in time view as at 16/12/2013.

Changes to legislation: There are currently no known outstanding effects for the Commission Delegated Regulation (EU) No 134/2014. (See end of Document for details)

ECE R40-based test cycle tolerances

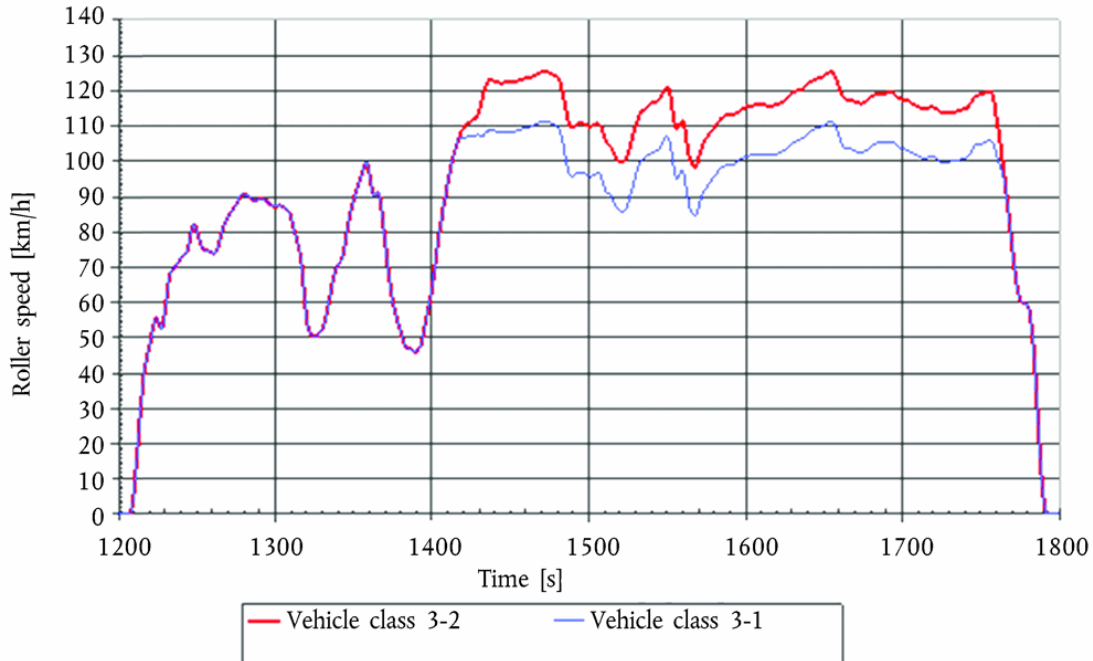

4. Generic applicable ECE R40 and R47 test cycle tolerances

- 4.1. A tolerance of 1 km/h over or under the theoretical speed shall be allowed during all phases of the test cycle. Speed tolerances greater than those prescribed shall be accepted during phase changes provided that the tolerances are not exceeded for more than 0,5 second on any occasion, without prejudice to the provisions of points 4.3. and 4.4. The time tolerance shall be + 0,5 sec.
- 4.2. The distance driven during the cycle shall be measured to (0 / + 2) percent.
- 4.3. If the acceleration capability of the L-category vehicle is not sufficient to carry out the acceleration phases within the prescribed limits of tolerances or the prescribed maximum vehicle speed in the individual cycles cannot be achieved owing to a lack of propulsion power, the vehicle shall be driven with the throttle fully open until the speed prescribed for the cycle is reached and the cycle shall be carried on normally.
- 4.4. If the period of deceleration is shorter than that prescribed for the corresponding phase, the timing of the theoretical cycle shall be restored by a constant speed or idling period merging into the subsequent constant speed or idling operation. In such cases, point 4.1 shall not apply.

5. Sampling of the exhaust flow of the vehicle in the ECE R40 and R47 test cycles

- 5.1. Check of back-pressure from sampling device

During the preliminary tests, a check shall be made to ensure that the back-pressure set up by the sampling device is equal to the atmospheric pressure to within $\pm 1\ 230$ Pa.

- 5.2. Sampling shall start as of $t=0$ just before cranking and starting-up of the combustion engine if that engine makes part of the propulsion type.

Status: Point in time view as at 16/12/2013.

Changes to legislation: There are currently no known outstanding effects for the Commission Delegated Regulation (EU) No 134/2014. (See end of Document for details)

5.3. The combustion engine shall be started up by means of the devices provided for that purpose — the choke, the starter valve, etc. — in accordance with the manufacturer’s instructions.

5.4. The sampling bags shall be hermetically closed as soon as filling is completed.

5.5. At the end of the test cycle, the system for collecting dilute exhaust mixture and dilution air shall be closed and the gases produced by the engine shall be released into the atmosphere.

6. Gearshift procedures

6.1. The ECE R47 test shall be conducted using the gearshift procedure set out in point 2.3 of UNECE regulation No 47.

6.2. The ECE R40 test shall be conducted using the gearshift procedure set out in point 2.3 of UNECE regulation No 40.

(3) World Harmonised Motorcycle Test Cycle (WMTC), stage 2

1. Description of the test cycle

The WMTC stage 2 to be used on the chassis dynamometer shall be as depicted in the following graph:

Figure Ap6-5

WMTC stage 2

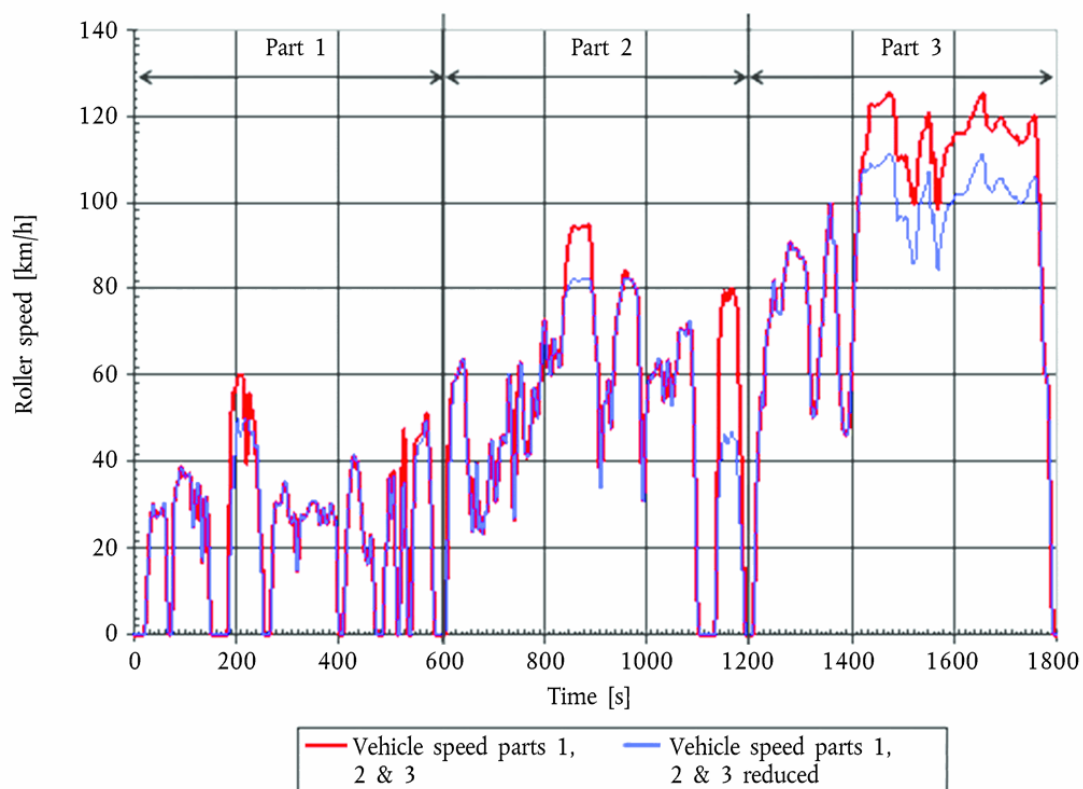

Status: Point in time view as at 16/12/2013.

Changes to legislation: There are currently no known outstanding effects for the Commission Delegated Regulation (EU) No 134/2014. (See end of Document for details)

1.1. The WMTC stage 2 includes the same vehicle speed trace as WMTC stage 1 with supplemental gear shift prescriptions. The WMTC stage 2 lasts 1 800 seconds and consists of three parts to be carried out without interruption. The characteristic driving conditions (idling, acceleration, steady speed, deceleration, etc.) are set out in the following points and tables.

2. WMTC stage 2, cycle part 1

Figure Ap6-6

WMTC stage 2, part 1

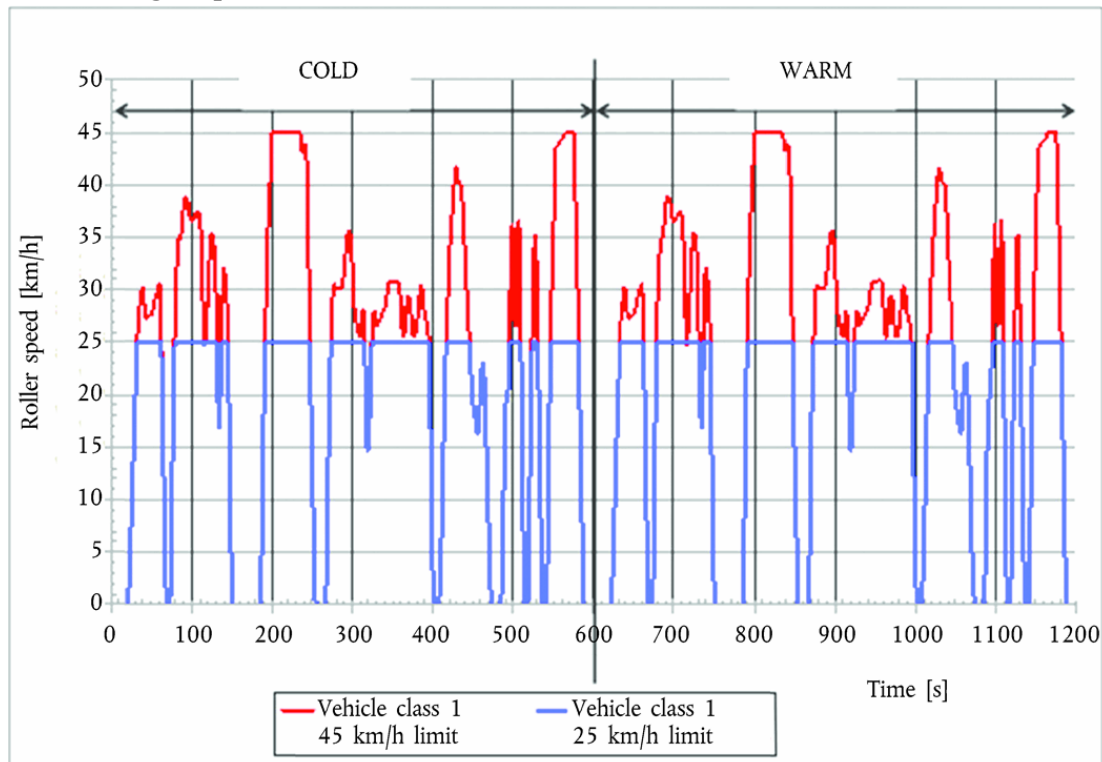

2.1 The WMTC stage 2 includes the same vehicle speed trace as WMTC stage 1 with supplemental gear shift prescriptions. The characteristic roller speed versus test time of WMTC stage 2, cycle part 1 is set out in the following tables.

2.2.1. TABLE AP6-3

WMTC stage 2, cycle part 1, reduced speed for vehicle classes 1 and 2-1, 0 to 180 s.

time in s	roller speed in km/h	phase indicators			
		stop	acc	cruise	dec
0	0,0	X			
1	0,0	X			
2	0,0	X			
3	0,0	X			
4	0,0	X			

Status: Point in time view as at 16/12/2013.

Changes to legislation: There are currently no known outstanding effects for the Commission Delegated Regulation (EU) No 134/2014. (See end of Document for details)

5	0,0	X			
6	0,0	X			
7	0,0	X			
8	0,0	X			
9	0,0	X			
10	0,0	X			
11	0,0	X			
12	0,0	X			
13	0,0	X			
14	0,0	X			
15	0,0	X			
16	0,0	X			
17	0,0	X			
18	0,0	X			
19	0,0	X			
20	0,0	X			
21	0,0	X			
22	1,0		X		
23	2,6		X		
24	4,8		X		
25	7,2		X		
26	9,6		X		
27	12,0		X		
28	14,3		X		
29	16,6		X		
30	18,9		X		
31	21,2		X		
32	23,5		X		
33	25,6		X		
34	27,1		X		
35	28,0		X		
36	28,7		X		
37	29,2		X		
38	29,8		X		

Status: Point in time view as at 16/12/2013.

Changes to legislation: There are currently no known outstanding effects for the Commission Delegated Regulation (EU) No 134/2014. (See end of Document for details)

39	30,3			X	
40	29,6			X	
41	28,7			X	
42	27,9			X	
43	27,4			X	
44	27,3			X	
45	27,3			X	
46	27,4			X	
47	27,5			X	
48	27,6			X	
49	27,6			X	
50	27,6			X	
51	27,8			X	
52	28,1			X	
53	28,5			X	
54	28,9			X	
55	29,2			X	
56	29,4			X	
57	29,7			X	
58	30,0			X	
59	30,5			X	
60	30,6				X
61	29,6				X
62	26,9				X
63	23,0				X
64	18,6				X
65	14,1				X
66	9,3				X
67	4,8				X
68	1,9				X
69	0,0	X			
70	0,0	X			
71	0,0	X			
72	0,0	X			

LIST OF ANNEXES

Document Generated: 2023-10-14

Status: Point in time view as at 16/12/2013.**Changes to legislation:** There are currently no known outstanding effects for the Commission Delegated Regulation (EU) No 134/2014. (See end of Document for details)

73	0,0	X			
74	1,7		X		
75	5,8		X		
76	11,8		X		
77	17,3		X		
78	22,0		X		
79	26,2		X		
80	29,4		X		
81	31,1		X		
82	32,9		X		
83	34,7		X		
84	34,8		X		
85	34,8		X		
86	34,9		X		
87	35,4		X		
88	36,2		X		
89	37,1		X		
90	38,0		X		
91	38,7			X	
92	38,9			X	
93	38,9			X	
94	38,8			X	
95	38,5			X	
96	38,1			X	
97	37,5			X	
98	37,0			X	
99	36,7			X	
100	36,5			X	
101	36,5			X	
102	36,6			X	
103	36,8			X	
104	37,0			X	
105	37,1			X	
106	37,3			X	

Status: Point in time view as at 16/12/2013.

Changes to legislation: There are currently no known outstanding effects for the Commission Delegated Regulation (EU) No 134/2014. (See end of Document for details)

107	37,4			X	
108	37,5			X	
109	37,4			X	
110	36,9				X
111	36,0				X
112	34,8				X
113	31,9				X
114	29,0				X
115	26,9				X
116	24,7			X	
117	25,4			X	
118	26,4			X	
119	27,7			X	
120	29,4			X	
121	31,2			X	
122	33,0			X	
123	34,4			X	
124	35,2			X	
125	35,4				X
126	35,2				X
127	34,7				X
128	33,9				X
129	32,4				X
130	29,8				X
131	26,1				X
132	22,1				X
133	18,6				X
134	16,8		X		
135	17,7		X		
136	21,1		X		
137	25,4		X		
138	29,2		X		
139	31,6		X		

Status: Point in time view as at 16/12/2013.

Changes to legislation: There are currently no known outstanding effects for the Commission Delegated Regulation (EU) No 134/2014. (See end of Document for details)

140	32,1				X
141	31,6				X
142	30,7				X
143	29,7				X
144	28,1				X
145	25,0				X
146	20,3				X
147	15,0				X
148	9,7				X
149	5,0				X
150	1,6				X
151	0,0	X			
152	0,0	X			
153	0,0	X			
154	0,0	X			
155	0,0	X			
156	0,0	X			
157	0,0	X			
158	0,0	X			
159	0,0	X			
160	0,0	X			
161	0,0	X			
162	0,0	X			
163	0,0	X			
164	0,0	X			
165	0,0	X			
166	0,0	X			
167	0,0	X			
168	0,0	X			
169	0,0	X			
170	0,0	X			
171	0,0	X			
172	0,0	X			
173	0,0	X			

Status: Point in time view as at 16/12/2013.

Changes to legislation: There are currently no known outstanding effects for the Commission Delegated Regulation (EU) No 134/2014. (See end of Document for details)

174	0,0	X			
175	0,0	X			
176	0,0	X			
177	0,0	X			
178	0,0	X			
179	0,0	X			
180	0,0	X			

2.2.2.

TABLE AP6-4

WMTC stage 2, cycle part 1, reduced speed for vehicle classes 1 and 2-1, 181 to 360 s

time in s	roller speed in km/h	phase indicators			
		stop	acc	cruise	dec
181	0,0	X			
182	0,0	X			
183	0,0	X			
184	0,0	X			
185	0,4		X		
186	1,8		X		
187	5,4		X		
188	11,1		X		
189	16,7		X		
190	21,3		X		
191	24,8		X		
192	28,4		X		
193	31,8		X		
194	34,6		X		
195	36,3		X		
196	37,8		X		
197	39,6		X		
198	41,3		X		
199	43,3		X		
200	45,1		X		
201	47,5		X		

Status: Point in time view as at 16/12/2013.

Changes to legislation: There are currently no known outstanding effects for the Commission Delegated Regulation (EU) No 134/2014. (See end of Document for details)

202	49,0		X		
203	50,0			X	
204	49,5			X	
205	48,8			X	
206	47,6			X	
207	46,5			X	
208	46,1			X	
209	46,1			X	
210	46,6			X	
211	46,9			X	
212	47,2			X	
213	47,8			X	
214	48,4			X	
215	48,9			X	
216	49,2			X	
217	49,6			X	
218	49,9			X	
219	50,0			X	
220	49,8			X	
221	49,5			X	
222	49,2			X	
223	49,3			X	
224	49,4			X	
225	49,4			X	
226	48,6			X	
227	47,8			X	
228	47,0			X	
229	46,9			X	
230	46,6			X	
231	46,6			X	
232	46,6			X	
233	46,9			X	
234	46,4			X	
235	45,6			X	

Status: Point in time view as at 16/12/2013.

Changes to legislation: There are currently no known outstanding effects for the Commission Delegated Regulation (EU) No 134/2014. (See end of Document for details)

236	44,4			X	
237	43,5			X	
238	43,2			X	
239	43,3			X	
240	43,7			X	
241	43,9			X	
242	43,8				X
243	43,0				X
244	40,9				X
245	36,9				X
246	32,1				X
247	26,6				X
248	21,8				X
249	17,2				X
250	13,7				X
251	10,3				X
252	7,0				X
253	3,5				X
254	0,0	X			
255	0,0	X			
256	0,0	X			
257	0,0	X			
258	0,0	X			
259	0,0	X			
260	0,0	X			
261	0,0	X			
262	0,0	X			
263	0,0	X			
264	0,0	X			
265	0,0	X			
266	0,0	X			
267	0,5		X		
268	2,9		X		
269	8,2		X		

LIST OF ANNEXES

Document Generated: 2023-10-14

Status: Point in time view as at 16/12/2013.**Changes to legislation:** There are currently no known outstanding effects for the Commission Delegated Regulation (EU) No 134/2014. (See end of Document for details)

270	13,2		X		
271	17,8		X		
272	21,4		X		
273	24,1		X		
274	26,4		X		
275	28,4		X		
276	29,9		X		
277	30,5			X	
278	30,5			X	
279	30,3			X	
280	30,2			X	
281	30,1			X	
282	30,1			X	
283	30,1			X	
284	30,2			X	
285	30,2			X	
286	30,2			X	
287	30,2			X	
288	30,5			X	
289	31,0			X	
290	31,9			X	
291	32,8			X	
292	33,7			X	
293	34,5			X	
294	35,1			X	
295	35,5			X	
296	35,6			X	
297	35,4			X	
298	35,0			X	
299	34,0			X	
300	32,4			X	
301	30,6			X	
302	29,0			X	
303	27,8			X	

Status: Point in time view as at 16/12/2013.

Changes to legislation: There are currently no known outstanding effects for the Commission Delegated Regulation (EU) No 134/2014. (See end of Document for details)

304	27,2			X	
305	26,9			X	
306	26,5			X	
307	26,1			X	
308	25,7			X	
309	25,5			X	
310	25,7			X	
311	26,4			X	
312	27,3			X	
313	28,1			X	
314	27,9				X
315	26,0				X
316	22,7				X
317	19,0				X
318	16,0				X
319	14,6		X		
320	15,2		X		
321	16,9		X		
322	19,3		X		
323	22,0		X		
324	24,6		X		
325	26,8		X		
326	27,9		X		
327	28,0			X	
328	27,7			X	
329	27,1			X	
330	26,8			X	
331	26,6			X	
332	26,8			X	
333	27,0			X	
334	27,2			X	
335	27,4			X	
336	27,5			X	
337	27,7			X	

Status: Point in time view as at 16/12/2013.

Changes to legislation: There are currently no known outstanding effects for the Commission Delegated Regulation (EU) No 134/2014. (See end of Document for details)

338	27,9			X	
339	28,1			X	
340	28,3			X	
341	28,6			X	
342	29,1			X	
343	29,6			X	
344	30,1			X	
345	30,6			X	
346	30,8			X	
347	30,8			X	
348	30,8			X	
349	30,8			X	
350	30,8			X	
351	30,8			X	
352	30,8			X	
353	30,8			X	
354	30,9			X	
355	30,9			X	
356	30,9			X	
357	30,8			X	
358	30,4			X	
359	29,6			X	
360	28,4			X	

2.2.3.

TABLE AP6-5

WMTC stage 2, cycle part 1, reduced speed for vehicle classes 1 and 2-1, 361 to 540 s

time in s	roller speed in km/h	phase indicators			
		stop	acc	cruise	dec
361	27,1			X	
362	26,0			X	
363	25,4			X	
364	25,5			X	
365	26,3			X	
366	27,3			X	

Status: Point in time view as at 16/12/2013.

Changes to legislation: There are currently no known outstanding effects for the Commission Delegated Regulation (EU) No 134/2014. (See end of Document for details)

367	28,3			X	
368	29,2			X	
369	29,5			X	
370	29,4			X	
371	28,9			X	
372	28,1			X	
373	27,1			X	
374	26,3			X	
375	25,7			X	
376	25,5			X	
377	25,6			X	
378	25,9			X	
379	26,3			X	
380	26,9			X	
381	27,6			X	
382	28,4			X	
383	29,3			X	
384	30,1			X	
385	30,4			X	
386	30,2			X	
387	29,5			X	
388	28,6			X	
389	27,9			X	
390	27,5			X	
391	27,2			X	
392	26,9				X
393	26,4				X
394	25,7				X
395	24,9				X
396	21,4				X
397	15,9				X
398	9,9				X
399	4,9				X
400	2,1				X

Status: Point in time view as at 16/12/2013.

Changes to legislation: There are currently no known outstanding effects for the Commission Delegated Regulation (EU) No 134/2014. (See end of Document for details)

401	0,9				X
402	0,0	X			
403	0,0	X			
404	0,0	X			
405	0,0	X			
406	0,0	X			
407	0,0	X			
408	1,2		X		
409	3,2		X		
410	5,9		X		
411	8,8		X		
412	12,0		X		
413	15,4		X		
414	18,9		X		
415	22,1		X		
416	24,7		X		
417	26,8		X		
418	28,7		X		
419	30,6		X		
420	32,4		X		
421	34,0		X		
422	35,4		X		
423	36,5		X		
424	37,5		X		
425	38,6		X		
426	39,6		X		
427	40,7		X		
428	41,4		X		
429	41,7			X	
430	41,4			X	
431	40,9			X	
432	40,5			X	
433	40,2			X	
434	40,1			X	

Status: Point in time view as at 16/12/2013.

Changes to legislation: There are currently no known outstanding effects for the Commission Delegated Regulation (EU) No 134/2014. (See end of Document for details)

435	40,1			X	
436	39,8				X
437	38,9				X
438	37,4				X
439	35,8				X
440	34,1				X
441	32,5				X
442	30,9				X
443	29,4				X
444	27,9				X
445	26,5				X
446	25,0				X
447	23,4				X
448	21,8				X
449	20,3				X
450	19,3				X
451	18,7				X
452	18,3				X
453	17,8				X
454	17,4				X
455	16,8				X
456	16,3			X	
457	16,5			X	
458	17,6			X	
459	19,2			X	
460	20,8			X	
461	22,2			X	
462	23,0			X	
463	23,0				X
464	22,0				X
465	20,1				X
466	17,7				X
467	15,0				X
468	12,1				X

Status: Point in time view as at 16/12/2013.

Changes to legislation: There are currently no known outstanding effects for the Commission Delegated Regulation (EU) No 134/2014. (See end of Document for details)

469	9,1				X
470	6,2				X
471	3,6				X
472	1,8				X
473	0,8				X
474	0,0	X			
475	0,0	X			
476	0,0	X			
477	0,0	X			
478	0,0	X			
479	0,0	X			
480	0,0	X			
481	0,0	X			
482	0,0	X			
483	0,0	X			
484	0,0	X			
485	0,0	X			
486	1,4		X		
487	4,5		X		
488	8,8		X		
489	13,4		X		
490	17,3		X		
491	19,2		X		
492	19,7		X		
493	19,8		X		
494	20,7		X		
495	23,7		X		
496	27,9		X		
497	31,9		X		
498	35,4		X		
499	36,2				X
500	34,2				X
501	30,2				X
502	27,1				X

Status: Point in time view as at 16/12/2013.

Changes to legislation: There are currently no known outstanding effects for the Commission Delegated Regulation (EU) No 134/2014. (See end of Document for details)

503	26,6		X		
504	28,6		X		
505	32,6		X		
506	35,5		X		
507	36,6				X
508	34,6				X
509	30,0				X
510	23,1				X
511	16,7				X
512	10,7				X
513	4,7				X
514	1,2				X
515	0,0	X			
516	0,0	X			
517	0,0	X			
518	0,0	X			
519	3,0		X		
520	8,2		X		
521	14,3		X		
522	19,3		X		
523	23,5		X		
524	27,3		X		
525	30,8		X		
526	33,7		X		
527	35,2		X		
528	35,2				X
529	32,5				X
530	27,9				X
531	23,2				X
532	18,5				X
533	13,8				X
534	9,1				X
535	4,5				X
536	2,3				X

Status: Point in time view as at 16/12/2013.

Changes to legislation: There are currently no known outstanding effects for the Commission Delegated Regulation (EU) No 134/2014. (See end of Document for details)

537	0,0	X			
538	0,0	X			
539	0,0	X			
540	0,0	X			

2.2.4.

TABLE AP6-6

WMTC stage 2, cycle part 1, reduced speed for vehicle classes 1 and 2-1, 541 to 600 s

time in s	roller speed in km/h	phase indicators			
		stop	acc	cruise	dec
541	0,0	X			
542	2,8		X		
543	8,1		X		
544	14,3		X		
545	19,2		X		
546	23,5		X		
547	27,2		X		
548	30,5		X		
549	33,1		X		
550	35,7		X		
551	38,3		X		
552	41,0		X		
553	43,6			X	
554	43,7			X	
555	43,8			X	
556	43,9			X	
557	44,0			X	
558	44,1			X	
559	44,2			X	
560	44,3			X	
561	44,4			X	
562	44,5			X	
563	44,6			X	
564	44,9			X	
565	45,5			X	

Status: Point in time view as at 16/12/2013.

Changes to legislation: There are currently no known outstanding effects for the Commission Delegated Regulation (EU) No 134/2014. (See end of Document for details)

566	46,3			X	
567	47,1			X	
568	48,0			X	
569	48,7			X	
570	49,2			X	
571	49,4			X	
572	49,3			X	
573	48,7				X
574	47,3				X
575	45,0				X
576	42,3				X
577	39,5				X
578	36,6				X
579	33,7				X
580	30,1				X
581	26,0				X
582	21,8				X
583	17,7				X
584	13,5				X
585	9,4				X
586	5,6				X
587	2,1				X
588	0,0	X			
589	0,0	X			
590	0,0	X			
591	0,0	X			
592	0,0	X			
593	0,0	X			
594	0,0	X			
595	0,0	X			
596	0,0	X			
597	0,0	X			
598	0,0	X			
599	0,0	X			

Status: Point in time view as at 16/12/2013.

Changes to legislation: There are currently no known outstanding effects for the Commission Delegated Regulation (EU) No 134/2014. (See end of Document for details)

600	0,0	X			
-----	-----	---	--	--	--

2.2.5.

TABLE AP6-7

WMTC stage 2, cycle part 1 for vehicle classes 2-2 and 3, 0 to 180 s

time in s	roller speed in km/h	phase indicators			
		stop	acc	cruise	dec
0	0,0	X			
1	0,0	X			
2	0,0	X			
3	0,0	X			
4	0,0	X			
5	0,0	X			
6	0,0	X			
7	0,0	X			
8	0,0	X			
9	0,0	X			
10	0,0	X			
11	0,0	X			
12	0,0	X			
13	0,0	X			
14	0,0	X			
15	0,0	X			
16	0,0	X			
17	0,0	X			
18	0,0	X			
19	0,0	X			
20	0,0	X			
21	0,0	X			
22	1,0		X		
23	2,6		X		
24	4,8		X		
25	7,2		X		
26	9,6		X		
27	12,0		X		
28	14,3		X		

Status: Point in time view as at 16/12/2013.

Changes to legislation: There are currently no known outstanding effects for the Commission Delegated Regulation (EU) No 134/2014. (See end of Document for details)

29	16,6		X		
30	18,9		X		
31	21,2		X		
32	23,5		X		
33	25,6		X		
34	27,1		X		
35	28,0		X		
36	28,7		X		
37	29,2		X		
38	29,8		X		
39	30,4			X	
40	29,6			X	
41	28,7			X	
42	27,9			X	
43	27,5			X	
44	27,3			X	
45	27,4			X	
46	27,5			X	
47	27,6			X	
48	27,6			X	
49	27,6			X	
50	27,7			X	
51	27,8			X	
52	28,1			X	
53	28,6			X	
54	29,0			X	
55	29,2			X	
56	29,5			X	
57	29,7			X	
58	30,1			X	
59	30,5			X	
60	30,7			X	
61	29,7				X
62	27,0				X

Status: Point in time view as at 16/12/2013.

Changes to legislation: There are currently no known outstanding effects for the Commission Delegated Regulation (EU) No 134/2014. (See end of Document for details)

63	23,0				X
64	18,7				X
65	14,2				X
66	9,4				X
67	4,9				X
68	2,0				X
69	0,0	X			
70	0,0	X			
71	0,0	X			
72	0,0	X			
73	0,0	X			
74	1,7		X		
75	5,8		X		
76	11,8		X		
77	18,3		X		
78	24,5		X		
79	29,4		X		
80	32,5		X		
81	34,2		X		
82	34,4		X		
83	34,5		X		
84	34,6		X		
85	34,7		X		
86	34,8		X		
87	35,2		X		
88	36,0		X		
89	37,0		X		
90	37,9		X		
91	38,6		X		
92	38,8			X	
93	38,8			X	
94	38,7			X	
95	38,5			X	
96	38,0			X	

Status: Point in time view as at 16/12/2013.

Changes to legislation: There are currently no known outstanding effects for the Commission Delegated Regulation (EU) No 134/2014. (See end of Document for details)

97	37,4			X	
98	36,9			X	
99	36,6			X	
100	36,4			X	
101	36,4			X	
102	36,5			X	
103	36,7			X	
104	36,9			X	
105	37,0			X	
106	37,2			X	
107	37,3			X	
108	37,4			X	
109	37,3			X	
110	36,8			X	
111	35,8				X
112	34,7				X
113	31,8				X
114	28,9				X
115	26,7				X
116	24,6			X	
117	25,2			X	
118	26,2			X	
119	27,6			X	
120	29,2			X	
121	31,0			X	
122	32,8			X	
123	34,3			X	
124	35,1			X	
125	35,3				X
126	35,1				X
127	34,6				X
128	33,7				X
129	32,2				X

LIST OF ANNEXES

Document Generated: 2023-10-14

Status: Point in time view as at 16/12/2013.**Changes to legislation:** There are currently no known outstanding effects for the Commission Delegated Regulation (EU) No 134/2014. (See end of Document for details)

130	29,6				X
131	26,0				X
132	22,0				X
133	18,5				X
134	16,6		X		
135	17,6		X		
136	21,0		X		
137	25,2		X		
138	29,1		X		
139	31,4		X		
140	31,9				X
141	31,4				X
142	30,6				X
143	29,5				X
144	28,0				X
145	24,9				X
146	20,2				X
147	14,8				X
148	9,5				X
149	4,8				X
150	1,4				X
151	0,0	X			
152	0,0	X			
153	0,0	X			
154	0,0	X			
155	0,0	X			
156	0,0	X			
157	0,0	X			
158	0,0	X			
159	0,0	X			
160	0,0	X			
161	0,0	X			
162	0,0	X			
163	0,0	X			

Status: Point in time view as at 16/12/2013.

Changes to legislation: There are currently no known outstanding effects for the Commission Delegated Regulation (EU) No 134/2014. (See end of Document for details)

164	0,0	X			
165	0,0	X			
166	0,0	X			
167	0,0	X			
168	0,0	X			
169	0,0	X			
170	0,0	X			
171	0,0	X			
172	0,0	X			
173	0,0	X			
174	0,0	X			
175	0,0	X			
176	0,0	X			
177	0,0	X			
178	0,0	X			
179	0,0	X			
180	0,0	X			

2.2.6.

TABLE AP6-8

WMTC stage 2, cycle part 1 for vehicle classes 2-2 and 3, 181 to 360 s

time in s	roller speed in km/h	phase indicators			
		stop	acc	cruise	dec
181	0,0	X			
182	0,0	X			
183	2,0		X		
184	6,0		X		
185	12,4		X		
186	21,4		X		
187	30,0		X		
188	37,1		X		
189	42,5		X		
190	46,6		X		
191	49,8		X		
192	52,4		X		

LIST OF ANNEXES

Document Generated: 2023-10-14

Status: Point in time view as at 16/12/2013.

Changes to legislation: There are currently no known outstanding effects for the Commission Delegated Regulation (EU) No 134/2014. (See end of Document for details)

193	54,4		X		
194	55,6		X		
195	56,1			X	
196	56,2			X	
197	56,2			X	
198	56,2			X	
199	56,7			X	
200	57,2			X	
201	57,7			X	
202	58,2			X	
203	58,7			X	
204	59,3			X	
205	59,8			X	
206	60,0			X	
207	60,0			X	
208	59,9			X	
209	59,9			X	
210	59,9			X	
211	59,9			X	
212	59,9			X	
213	59,8			X	
214	59,6				X
215	59,1				X
216	57,1				X
217	53,2				X
218	48,3				X
219	43,9				X
220	40,3				X
221	39,5				X
222	41,3		X		
223	45,2		X		
224	50,1		X		
225	53,7		X		
226	55,8		X		

Status: Point in time view as at 16/12/2013.

Changes to legislation: There are currently no known outstanding effects for the Commission Delegated Regulation (EU) No 134/2014. (See end of Document for details)

227	55,8				X
228	54,7				X
229	53,3				X
230	52,3				X
231	52,0				X
232	52,1				X
233	51,8				X
234	50,8				X
235	49,2				X
236	47,5				X
237	45,7				X
238	43,9				X
239	42,0				X
240	40,2				X
241	38,3				X
242	36,4				X
243	34,6				X
244	32,7				X
245	30,6				X
246	28,1				X
247	25,5				X
248	23,1				X
249	21,2				X
250	19,5				X
251	17,8				X
252	15,3				X
253	11,5				X
254	7,2				X
255	2,5				X
256	0,0	X			
257	0,0	X			
258	0,0	X			
259	0,0	X			
260	0,0	X			

Status: Point in time view as at 16/12/2013.

Changes to legislation: There are currently no known outstanding effects for the Commission Delegated Regulation (EU) No 134/2014. (See end of Document for details)

261	0,0	X			
262	0,0	X			
263	0,0	X			
264	0,0	X			
265	0,0	X			
266	0,0	X			
267	0,5		X		
268	2,9		X		
269	8,2		X		
270	13,2		X		
271	17,8		X		
272	21,4		X		
273	24,1		X		
274	26,4		X		
275	28,4		X		
276	29,9		X		
277	30,5		X		
278	30,5			X	
279	30,3			X	
280	30,2			X	
281	30,1			X	
282	30,1			X	
283	30,1			X	
284	30,1			X	
285	30,1			X	
286	30,1			X	
287	30,2			X	
288	30,4			X	
289	31,0			X	
290	31,8			X	
291	32,7			X	
292	33,6			X	
293	34,4			X	
294	35,0			X	

Status: Point in time view as at 16/12/2013.

Changes to legislation: There are currently no known outstanding effects for the Commission Delegated Regulation (EU) No 134/2014. (See end of Document for details)

295	35,4			X	
296	35,5			X	
297	35,3			X	
298	34,9			X	
299	33,9			X	
300	32,4			X	
301	30,6			X	
302	28,9			X	
303	27,8			X	
304	27,2			X	
305	26,9			X	
306	26,5			X	
307	26,1			X	
308	25,7			X	
309	25,5			X	
310	25,7			X	
311	26,4			X	
312	27,3			X	
313	28,1			X	
314	27,9				X
315	26,0				X
316	22,7				X
317	19,0				X
318	16,0				X
319	14,6		X		
320	15,2		X		
321	16,9		X		
322	19,3		X		
323	22,0		X		
324	24,6		X		
325	26,8		X		
326	27,9		X		
327	28,1			X	
328	27,7			X	

Status: Point in time view as at 16/12/2013.

Changes to legislation: There are currently no known outstanding effects for the Commission Delegated Regulation (EU) No 134/2014. (See end of Document for details)

329	27,2			X	
330	26,8			X	
331	26,6			X	
332	26,8			X	
333	27,0			X	
334	27,2			X	
335	27,4			X	
336	27,6			X	
337	27,7			X	
338	27,9			X	
339	28,1			X	
340	28,3			X	
341	28,6			X	
342	29,0			X	
343	29,6			X	
344	30,1			X	
345	30,5			X	
346	30,7			X	
347	30,8			X	
348	30,8			X	
349	30,8			X	
350	30,8			X	
351	30,8			X	
352	30,8			X	
353	30,8			X	
354	30,9			X	
355	30,9			X	
356	30,9			X	
357	30,8			X	
358	30,4			X	
359	29,6			X	
360	28,4			X	

2.2.7.

TABLE AP6-9

WMTC stage 2, cycle part 1 for vehicle classes 2-2 and 3, 361 to 540 s

Status: Point in time view as at 16/12/2013.

Changes to legislation: There are currently no known outstanding effects for the Commission Delegated Regulation (EU) No 134/2014. (See end of Document for details)

time in s	roller speed in km/h	phase indicators			
		stop	acc	cruise	dec
361	27,1			X	
362	26,0			X	
363	25,4			X	
364	25,5			X	
365	26,3			X	
366	27,3			X	
367	28,4			X	
368	29,2			X	
369	29,5			X	
370	29,5			X	
371	29,0			X	
372	28,1			X	
373	27,2			X	
374	26,3			X	
375	25,7			X	
376	25,5			X	
377	25,6			X	
378	26,0			X	
379	26,4			X	
380	27,0			X	
381	27,7			X	
382	28,5			X	
383	29,4			X	
384	30,2			X	
385	30,5			X	
386	30,3			X	
387	29,5			X	
388	28,7			X	
389	27,9			X	
390	27,5			X	
391	27,3			X	
392	27,0				X

Status: Point in time view as at 16/12/2013.

Changes to legislation: There are currently no known outstanding effects for the Commission Delegated Regulation (EU) No 134/2014. (See end of Document for details)

393	26,5				X
394	25,8				X
395	25,0				X
396	21,5				X
397	16,0				X
398	10,0				X
399	5,0				X
400	2,2				X
401	1,0				X
402	0,0	X			
403	0,0	X			
404	0,0	X			
405	0,0	X			
406	0,0	X			
407	0,0	X			
408	1,2		X		
409	3,2		X		
410	5,9		X		
411	8,8		X		
412	12,0		X		
413	15,4		X		
414	18,9		X		
415	22,1		X		
416	24,8		X		
417	26,8		X		
418	28,7		X		
419	30,6		X		
420	32,4		X		
421	34,0		X		
422	35,4		X		
423	36,5		X		
424	37,5		X		
425	38,6		X		
426	39,7		X		

Status: Point in time view as at 16/12/2013.

Changes to legislation: There are currently no known outstanding effects for the Commission Delegated Regulation (EU) No 134/2014. (See end of Document for details)

427	40,7		X		
428	41,5		X		
429	41,7			X	
430	41,5			X	
431	41,0			X	
432	40,6			X	
433	40,3			X	
434	40,2			X	
435	40,1			X	
436	39,8				X
437	38,9				X
438	37,5				X
439	35,8				X
440	34,2				X
441	32,5				X
442	30,9				X
443	29,4				X
444	28,0				X
445	26,5				X
446	25,0				X
447	23,5				X
448	21,9				X
449	20,4				X
450	19,4				X
451	18,8				X
452	18,4				X
453	18,0				X
454	17,5				X
455	16,9				X
456	16,4			X	
457	16,6			X	
458	17,7			X	
459	19,4			X	
460	20,9			X	

LIST OF ANNEXES

Document Generated: 2023-10-14

Status: Point in time view as at 16/12/2013.

Changes to legislation: There are currently no known outstanding effects for the Commission Delegated Regulation (EU) No 134/2014. (See end of Document for details)

461	22,3			X	
462	23,2			X	
463	23,2				X
464	22,2				X
465	20,3				X
466	17,9				X
467	15,2				X
468	12,3				X
469	9,3				X
470	6,4				X
471	3,8				X
472	2,0				X
473	0,9				X
474	0,0	X			
475	0,0	X			
476	0,0	X			
477	0,0	X			
478	0,0	X			
479	0,0	X			
480	0,0	X			
481	0,0	X			
482	0,0	X			
483	0,0	X			
484	0,0	X			
485	0,0	X			
486	1,4		X		
487	4,5		X		
488	8,8		X		
489	13,4		X		
490	17,3		X		
491	19,2		X		
492	19,7		X		
493	19,8		X		
494	20,7		X		

Status: Point in time view as at 16/12/2013.

Changes to legislation: There are currently no known outstanding effects for the Commission Delegated Regulation (EU) No 134/2014. (See end of Document for details)

495	23,6		X		
496	28,1		X		
497	32,8		X		
498	36,3		X		
499	37,1				X
500	35,1				X
501	31,1				X
502	28,0				X
503	27,5		X		
504	29,5		X		
505	34,0		X		
506	37,0		X		
507	38,0				X
508	36,1				X
509	31,5				X
510	24,5				X
511	17,5				X
512	10,5				X
513	4,5				X
514	1,0				X
515	0,0	X			
516	0,0	X			
517	0,0	X			
518	0,0	X			
519	2,9		X		
520	8,0		X		
521	16,0		X		
522	24,0		X		
523	32,0		X		
524	38,8		X		
525	43,1		X		
526	46,0		X		
527	47,5				X
528	47,5				X

Status: Point in time view as at 16/12/2013.

Changes to legislation: There are currently no known outstanding effects for the Commission Delegated Regulation (EU) No 134/2014. (See end of Document for details)

529	44,8				X
530	40,1				X
531	33,8				X
532	27,2				X
533	20,0				X
534	12,8				X
535	7,0				X
536	2,2				X
537	0,0	X			
538	0,0	X			
539	0,0	X			
540	0,0	X			

2.2.8

TABLE AP6-10

WMTC stage 2, cycle part 1 for vehicle classes 2-2 and 3, 541 to 600 s

time in s	roller speed in km/h	phase indicators			
		stop	acc	cruise	dec
541	0,0	X			
542	2,7		X		
543	8,0		X		
544	16,0		X		
545	24,0		X		
546	32,0		X		
547	37,2		X		
548	40,4		X		
549	43,1		X		
550	44,6		X		
551	45,2			X	
552	45,3			X	
553	45,4			X	
554	45,5			X	
555	45,6			X	
556	45,7			X	
557	45,8			X	
558	45,9			X	

Status: Point in time view as at 16/12/2013.

Changes to legislation: There are currently no known outstanding effects for the Commission Delegated Regulation (EU) No 134/2014. (See end of Document for details)

559	46,0			X	
560	46,1			X	
561	46,2			X	
562	46,3			X	
563	46,4			X	
564	46,7			X	
565	47,2			X	
566	48,0			X	
567	48,9			X	
568	49,8			X	
569	50,5			X	
570	51,0			X	
571	51,1			X	
572	51,0			X	
573	50,4				X
574	49,0				X
575	46,7				X
576	44,0				X
577	41,1				X
578	38,3				X
579	35,4				X
580	31,8				X
581	27,3				X
582	22,4				X
583	17,7				X
584	13,4				X
585	9,3				X
586	5,5				X
587	2,0				X
588	0,0	X			
589	0,0	X			
590	0,0	X			
591	0,0	X			
592	0,0	X			

Status: Point in time view as at 16/12/2013.

Changes to legislation: There are currently no known outstanding effects for the Commission Delegated Regulation (EU) No 134/2014. (See end of Document for details)

593	0,0	X			
594	0,0	X			
595	0,0	X			
596	0,0	X			
597	0,0	X			
598	0,0	X			
599	0,0	X			
600	0,0	X			

3. **WMTC stage 2, part 2**

Figure Ap6-7

WMTC stage 2, part 2

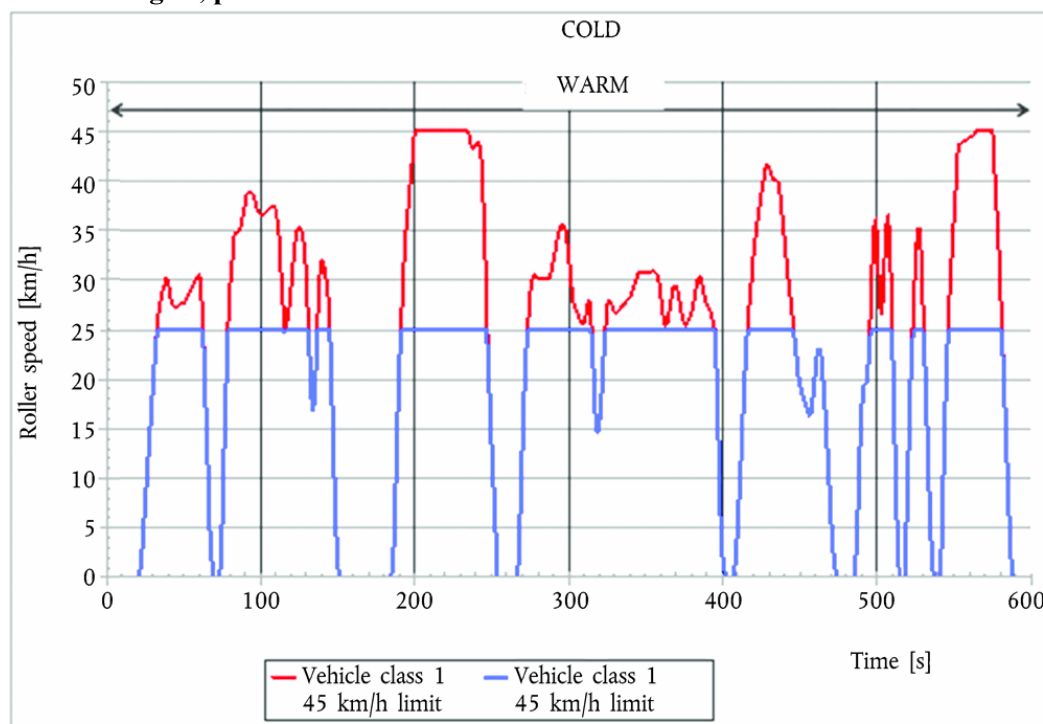

3.1. The WMTC stage 2 includes the same vehicle speed trace as WMTC stage 1 with supplemental gear shift prescriptions. The characteristic roller speed versus test time of WMTC stage 2, part 2 is set out in the following tables.

3.1.1. *TABLE AP6-11*

WMTC stage 2, cycle part 2, reduced speed for vehicle class 2-1, 0 to 180 s

time in s	roller speed in km/h	phase indicators			
		stop	acc	cruise	dec
0	0,0	X			

Status: Point in time view as at 16/12/2013.

Changes to legislation: There are currently no known outstanding effects for the Commission Delegated Regulation (EU) No 134/2014. (See end of Document for details)

1	0,0	X			
2	0,0	X			
3	0,0	X			
4	0,0	X			
5	0,0	X			
6	0,0	X			
7	0,0	X			
8	0,0	X			
9	2,3		X		
10	7,3		X		
11	13,6		X		
12	18,9		X		
13	23,6		X		
14	27,8		X		
15	31,8		X		
16	35,6		X		
17	39,3		X		
18	42,7		X		
19	46,0		X		
20	49,1		X		
21	52,1		X		
22	54,9		X		
23	57,5		X		
24	58,4			X	
25	58,5			X	
26	58,5			X	
27	58,6			X	
28	58,9			X	
29	59,3			X	
30	59,8			X	
31	60,2			X	
32	60,5			X	
33	60,8			X	
34	61,1			X	

LIST OF ANNEXES

Document Generated: 2023-10-14

Status: Point in time view as at 16/12/2013.

Changes to legislation: There are currently no known outstanding effects for the Commission Delegated Regulation (EU) No 134/2014. (See end of Document for details)

35	61,5			X	
36	62,0			X	
37	62,5			X	
38	63,0			X	
39	63,4			X	
40	63,7			X	
41	63,8			X	
42	63,9			X	
43	63,8			X	
44	63,2				X
45	61,7				X
46	58,9				X
47	55,2				X
48	51,0				X
49	46,7				X
50	42,8				X
51	40,2				X
52	38,8				X
53	37,9				X
54	36,7				X
55	35,1				X
56	32,9				X
57	30,4				X
58	28,0				X
59	25,9				X
60	24,4				X
61	23,7		X		
62	23,8		X		
63	25,0		X		
64	27,3		X		
65	30,4		X		
66	33,9		X		
67	37,3		X		
68	39,8				X

Status: Point in time view as at 16/12/2013.

Changes to legislation: There are currently no known outstanding effects for the Commission Delegated Regulation (EU) No 134/2014. (See end of Document for details)

69	39,5				X
70	36,3				X
71	31,4				X
72	26,5				X
73	24,2				X
74	24,8				X
75	26,6				X
76	27,5				X
77	26,8				X
78	25,3				X
79	24,0				X
80	23,3			X	
81	23,7			X	
82	24,9			X	
83	26,4			X	
84	27,7			X	
85	28,3			X	
86	28,3			X	
87	28,1			X	
88	28,1		X		
89	28,6		X		
90	29,8		X		
91	31,6		X		
92	33,9		X		
93	36,5		X		
94	39,1		X		
95	41,5		X		
96	43,3		X		
97	44,5		X		
98	45,1				X
99	45,1				X
100	43,9				X
101	41,4				X
102	38,4				X

LIST OF ANNEXES

Document Generated: 2023-10-14

Status: Point in time view as at 16/12/2013.**Changes to legislation:** There are currently no known outstanding effects for the Commission Delegated Regulation (EU) No 134/2014. (See end of Document for details)

103	35,5				X
104	32,9				X
105	31,3				X
106	30,7				X
107	31,0			X	
108	32,2			X	
109	34,0			X	
110	36,0			X	
111	37,9			X	
112	39,9			X	
113	41,6			X	
114	43,1			X	
115	44,3			X	
116	45,0			X	
117	45,5			X	
118	45,8			X	
119	46,0			X	
120	46,1			X	
121	46,2			X	
122	46,1			X	
123	45,7			X	
124	45,0			X	
125	44,3			X	
126	44,7		X		
127	46,8		X		
128	49,9		X		
129	52,8		X		
130	55,6		X		
131	58,2		X		
132	60,2				X
133	59,3				X
134	57,5				X
135	55,4				X

Status: Point in time view as at 16/12/2013.

Changes to legislation: There are currently no known outstanding effects for the Commission Delegated Regulation (EU) No 134/2014. (See end of Document for details)

136	52,5				X
137	47,9				X
138	41,4				X
139	34,4				X
140	30,0				X
141	27,0				X
142	26,5		X		
143	28,7		X		
144	32,7		X		
145	36,5		X		
146	40,0		X		
147	43,5		X		
148	46,7		X		
149	49,8		X		
150	52,7		X		
151	55,5		X		
152	58,1		X		
153	60,6		X		
154	62,9		X		
155	62,9				X
156	61,7				X
157	59,4				X
158	56,6				X
159	53,7				X
160	50,7				X
161	47,7				X
162	45,0				X
163	43,1				X
164	41,9			X	
165	41,6			X	
166	41,3			X	
167	40,9			X	
168	41,8			X	
169	42,1			X	

Status: Point in time view as at 16/12/2013.

Changes to legislation: There are currently no known outstanding effects for the Commission Delegated Regulation (EU) No 134/2014. (See end of Document for details)

170	41,8			X	
171	41,3			X	
172	41,5		X		
173	43,5		X		
174	46,5		X		
175	49,7		X		
176	52,6		X		
177	55,0		X		
178	56,5		X		
179	57,1		X		
180	57,3				X

3.1.2.

TABLE AP6-12

WMTC stage 2, cycle part 2, reduced speed for vehicle class 2-1, 181 to 360 s

time in s	roller speed in km/h	phase indicators			
		stop	acc	cruise	dec
181	57,0				X
182	56,3				X
183	55,2				X
184	53,9				X
185	52,6				X
186	51,4				X
187	50,1		X		
188	51,5		X		
189	53,1		X		
190	54,8		X		
191	56,6		X		
192	58,5		X		
193	60,6		X		
194	62,8		X		
195	64,9		X		
196	67,0		X		
197	69,1		X		
198	70,9		X		

Status: Point in time view as at 16/12/2013.

Changes to legislation: There are currently no known outstanding effects for the Commission Delegated Regulation (EU) No 134/2014. (See end of Document for details)

199	72,2		X		
200	72,8				X
201	72,8				X
202	71,9				X
203	70,5				X
204	68,8				X
205	67,1				X
206	65,4				X
207	63,9				X
208	62,8				X
209	61,8				X
210	61,0				X
211	60,4				X
212	60,0		X		
213	60,2		X		
214	61,4		X		
215	63,3		X		
216	65,5		X		
217	67,4		X		
218	68,5		X		
219	68,7				X
220	68,1				X
221	67,3				X
222	66,5				X
223	65,9				X
224	65,5				X
225	64,9				X
226	64,1				X
227	63,0				X
228	62,1				X
229	61,6		X		
230	61,7		X		
231	62,3		X		
232	63,5		X		

Status: Point in time view as at 16/12/2013.

Changes to legislation: There are currently no known outstanding effects for the Commission Delegated Regulation (EU) No 134/2014. (See end of Document for details)

233	65,3		X		
234	67,3		X		
235	69,2		X		
236	71,1		X		
237	73,0		X		
238	74,8		X		
239	75,7		X		
240	76,7		X		
241	77,5		X		
242	78,1			X	
243	78,6			X	
244	79,0			X	
245	79,4			X	
246	79,7			X	
247	80,1			X	
248	80,7			X	
249	80,8			X	
250	81,0			X	
251	81,2			X	
252	81,6			X	
253	81,9			X	
254	82,1			X	
255	82,1			X	
256	82,3			X	
257	82,4			X	
258	82,4			X	
259	82,3			X	
260	82,3			X	
261	82,2			X	
262	82,2			X	
263	82,1			X	
264	82,1			X	
265	82,0			X	
266	82,0			X	

Status: Point in time view as at 16/12/2013.

Changes to legislation: There are currently no known outstanding effects for the Commission Delegated Regulation (EU) No 134/2014. (See end of Document for details)

267	81,9			X	
268	81,9			X	
269	81,9			X	
270	81,9			X	
271	81,9			X	
272	82,0			X	
273	82,0			X	
274	82,1			X	
275	82,2			X	
276	82,3			X	
277	82,4			X	
278	82,5			X	
279	82,5			X	
280	82,5			X	
281	82,5			X	
282	82,4			X	
283	82,4			X	
284	82,4			X	
285	82,5			X	
286	82,5			X	
287	82,5			X	
288	82,4			X	
289	82,3			X	
290	81,6			X	
291	81,3			X	
292	80,3			X	
293	79,9			X	
294	79,2			X	
295	79,2			X	
296	78,4				X
297	75,7				X
298	73,2				X
299	71,1				X
300	69,5				X

Status: Point in time view as at 16/12/2013.

Changes to legislation: There are currently no known outstanding effects for the Commission Delegated Regulation (EU) No 134/2014. (See end of Document for details)

301	68,3				X
302	67,3				X
303	66,1				X
304	63,9				X
305	60,2				X
306	54,9				X
307	48,1				X
308	40,9				X
309	36,0				X
310	33,9				X
311	33,9		X		
312	36,5		X		
313	40,1		X		
314	43,5		X		
315	46,8		X		
316	49,8		X		
317	52,8		X		
318	53,9		X		
319	53,9		X		
320	53,7		X		
321	53,7		X		
322	54,3		X		
323	55,4		X		
324	56,8		X		
325	58,1		X		
326	58,9				X
327	58,2				X
328	55,8				X
329	52,6				X
330	49,2				X
331	47,6		X		
332	48,4		X		
333	51,4		X		
334	54,2		X		

Status: Point in time view as at 16/12/2013.

Changes to legislation: There are currently no known outstanding effects for the Commission Delegated Regulation (EU) No 134/2014. (See end of Document for details)

335	56,9		X		
336	59,4		X		
337	61,8		X		
338	64,1		X		
339	66,2		X		
340	68,2		X		
341	70,2		X		
342	72,0		X		
343	73,7		X		
344	74,4		X		
345	75,1		X		
346	75,8		X		
347	76,5		X		
348	77,2		X		
349	77,8		X		
350	78,5		X		
351	79,2		X		
352	80,0		X		
353	81,0			X	
354	81,2			X	
355	81,8			X	
356	82,2			X	
357	82,2			X	
358	82,4			X	
359	82,5			X	
360	82,5			X	

3.1.3.

TABLE AP6-13

WMTC stage 2, cycle part 2, reduced speed for vehicle class 2-1, 361 to 540 s

time in s	roller speed in km/h	phase indicators			
		stop	acc	cruise	dec
361	82,5			X	
362	82,5			X	
363	82,3			X	
364	82,1			X	

Status: Point in time view as at 16/12/2013.

Changes to legislation: There are currently no known outstanding effects for the Commission Delegated Regulation (EU) No 134/2014. (See end of Document for details)

365	82,1			X	
366	82,1			X	
367	82,1			X	
368	82,1			X	
369	82,1			X	
370	82,1			X	
371	82,1			X	
372	82,1			X	
373	81,9			X	
374	81,6			X	
375	81,3			X	
376	81,1			X	
377	80,8			X	
378	80,6			X	
379	80,4			X	
380	80,1			X	
381	79,7				X
382	78,6				X
383	76,8				X
384	73,7				X
385	69,4				X
386	64,0				X
387	58,6				X
388	53,2				X
389	47,8				X
390	42,4				X
391	37,0				X
392	33,0				X
393	30,9				X
394	30,9		X		
395	33,5		X		
396	37,2		X		
397	40,8		X		
398	44,2		X		

Status: Point in time view as at 16/12/2013.

Changes to legislation: There are currently no known outstanding effects for the Commission Delegated Regulation (EU) No 134/2014. (See end of Document for details)

399	47,4		X		
400	50,4		X		
401	53,3		X		
402	56,1		X		
403	57,3		X		
404	58,1		X		
405	58,8		X		
406	59,4		X		
407	59,8			X	
408	59,7			X	
409	59,4			X	
410	59,2			X	
411	59,2			X	
412	59,6			X	
413	60,0			X	
414	60,5			X	
415	61,0			X	
416	61,2			X	
417	61,3			X	
418	61,4			X	
419	61,7			X	
420	62,3			X	
421	63,1			X	
422	63,6			X	
423	63,9			X	
424	63,8			X	
425	63,6			X	
426	63,3				X
427	62,8				X
428	61,9				X
429	60,5				X
430	58,6				X
431	56,5				X
432	54,6				X

Status: Point in time view as at 16/12/2013.

Changes to legislation: There are currently no known outstanding effects for the Commission Delegated Regulation (EU) No 134/2014. (See end of Document for details)

433	53,8			X	
434	54,5			X	
435	56,1			X	
436	57,9			X	
437	59,7			X	
438	61,2			X	
439	62,3			X	
440	63,1			X	
441	63,6				X
442	63,5				X
443	62,7				X
444	60,9				X
445	58,7				X
446	56,4				X
447	54,5				X
448	53,3				X
449	53,0			X	
450	53,5			X	
451	54,6			X	
452	56,1			X	
453	57,6			X	
454	58,9			X	
455	59,8			X	
456	60,3			X	
457	60,7			X	
458	61,3			X	
459	62,4			X	
460	64,1			X	
461	66,2			X	
462	68,1			X	
463	69,7			X	
464	70,4			X	
465	70,7			X	
466	70,7			X	

Status: Point in time view as at 16/12/2013.

Changes to legislation: There are currently no known outstanding effects for the Commission Delegated Regulation (EU) No 134/2014. (See end of Document for details)

467	70,7			X	
468	70,7			X	
469	70,6			X	
470	70,5			X	
471	70,4			X	
472	70,2			X	
473	70,1			X	
474	69,8			X	
475	69,5			X	
476	69,1			X	
477	69,1			X	
478	69,5			X	
479	70,3			X	
480	71,2			X	
481	72,0			X	
482	72,6			X	
483	72,8			X	
484	72,7			X	
485	72,0				X
486	70,4				X
487	67,7				X
488	64,4				X
489	61,0				X
490	57,6				X
491	54,0				X
492	49,7				X
493	44,4				X
494	38,2				X
495	31,2				X
496	24,0				X
497	16,8				X
498	10,4				X
499	5,7				X
500	2,8				X

LIST OF ANNEXES

Document Generated: 2023-10-14

Status: Point in time view as at 16/12/2013.

Changes to legislation: There are currently no known outstanding effects for the Commission Delegated Regulation (EU) No 134/2014. (See end of Document for details)

501	1,6				X
502	0,3				X
503	0,0	X			
504	0,0	X			
505	0,0	X			
506	0,0	X			
507	0,0	X			
508	0,0	X			
509	0,0	X			
510	0,0	X			
511	0,0	X			
512	0,0	X			
513	0,0	X			
514	0,0	X			
515	0,0	X			
516	0,0	X			
517	0,0	X			
518	0,0	X			
519	0,0	X			
520	0,0	X			
521	0,0	X			
522	0,0	X			
523	0,0	X			
524	0,0	X			
525	0,0	X			
526	0,0	X			
527	0,0	X			
528	0,0	X			
529	0,0	X			
530	0,0	X			
531	0,0	X			
532	0,0	X			
533	2,3		X		
534	7,2		X		

Status: Point in time view as at 16/12/2013.

Changes to legislation: There are currently no known outstanding effects for the Commission Delegated Regulation (EU) No 134/2014. (See end of Document for details)

535	13,5		X		
536	18,7		X		
537	22,9		X		
538	26,7		X		
539	30,0		X		
540	32,8		X		

3.1.4.

TABLE AP6-14

WMTC stage 2, cycle part 2, reduced speed for vehicle class 2-1, 541 to 600 s

time in s	roller speed in km/h	phase indicators			
		stop	acc	cruise	dec
541	35,2		X		
542	37,3		X		
543	39,1		X		
544	40,8		X		
545	41,8		X		
546	42,5		X		
547	43,3		X		
548	44,1		X		
549	45,0		X		
550	45,7		X		
551	46,2			X	
552	46,3			X	
553	46,1			X	
554	45,6			X	
555	44,9			X	
556	44,4			X	
557	44,0			X	
558	44,0			X	
559	44,3			X	
560	44,8			X	
561	45,3			X	
562	45,9			X	
563	46,5			X	
564	46,8			X	

Status: Point in time view as at 16/12/2013.

Changes to legislation: There are currently no known outstanding effects for the Commission Delegated Regulation (EU) No 134/2014. (See end of Document for details)

565	47,1			X	
566	47,1			X	
567	47,0			X	
568	46,7			X	
569	46,3			X	
570	45,9			X	
571	45,6			X	
572	45,4			X	
573	45,2			X	
574	45,1			X	
575	44,8				X
576	43,5				X
577	40,9				X
578	38,2				X
579	35,6				X
580	33,0				X
581	30,4				X
582	27,7				X
583	25,1				X
584	22,5				X
585	19,8				X
586	17,2				X
587	14,6				X
588	12,0				X
589	9,3				X
590	6,7				X
591	4,1				X
592	1,5				X
593	0,0	X			
594	0,0	X			
595	0,0	X			
596	0,0	X			
597	0,0	X			
598	0,0	X			

Status: Point in time view as at 16/12/2013.

Changes to legislation: There are currently no known outstanding effects for the Commission Delegated Regulation (EU) No 134/2014. (See end of Document for details)

599	0,0	X			
600	0,0	X			

3.1.5.

TABLE AP6-15

WMTC stage 2, cycle part 2 for vehicle classes 2-2 and 3, 0 to 180 s

time in s	roller speed in km/h	phase indicators			
		stop	acc	cruise	dec
0	0,0	X			
1	0,0	X			
2	0,0	X			
3	0,0	X			
4	0,0	X			
5	0,0	X			
6	0,0	X			
7	0,0	X			
8	0,0	X			
9	2,3		X		
10	7,3		X		
11	15,2		X		
12	23,9		X		
13	32,5		X		
14	39,2		X		
15	44,1		X		
16	48,1		X		
17	51,2		X		
18	53,3		X		
19	54,5		X		
20	55,7		X		
21	56,9			X	
22	57,5			X	
23	58,0			X	
24	58,4			X	
25	58,5			X	
26	58,5			X	
27	58,6			X	

LIST OF ANNEXES

Document Generated: 2023-10-14

Status: Point in time view as at 16/12/2013.**Changes to legislation:** There are currently no known outstanding effects for the Commission Delegated Regulation (EU) No 134/2014. (See end of Document for details)

28	58,9			X	
29	59,3			X	
30	59,8			X	
31	60,2			X	
32	60,5			X	
33	60,8			X	
34	61,1			X	
35	61,5			X	
36	62,0			X	
37	62,5			X	
38	63,0			X	
39	63,4			X	
40	63,7			X	
41	63,8			X	
42	63,9			X	
43	63,8			X	
44	63,2				X
45	61,7				X
46	58,9				X
47	55,2				X
48	51,0				X
49	46,7				X
50	42,8				X
51	40,2				X
52	38,8				X
53	37,9				X
54	36,7				X
55	35,1				X
56	32,9				X
57	30,4				X
58	28,0				X
59	25,9				X
60	24,4				X
61	23,7		X		

Status: Point in time view as at 16/12/2013.

Changes to legislation: There are currently no known outstanding effects for the Commission Delegated Regulation (EU) No 134/2014. (See end of Document for details)

62	23,8		X		
63	25,0		X		
64	27,3		X		
65	30,4		X		
66	33,9		X		
67	37,3		X		
68	39,8		X		
69	39,5				X
70	36,3				X
71	31,4				X
72	26,5				X
73	24,2				X
74	24,8				X
75	26,6				X
76	27,5				X
77	26,8				X
78	25,3				X
79	24,0				X
80	23,3			X	
81	23,7			X	
82	24,9			X	
83	26,4			X	
84	27,7			X	
85	28,3			X	
86	28,3			X	
87	28,1			X	
88	28,1			X	
89	28,6			X	
90	29,8			X	
91	31,6			X	
92	33,9			X	
93	36,5			X	
94	39,1			X	
95	41,5			X	

Status: Point in time view as at 16/12/2013.

Changes to legislation: There are currently no known outstanding effects for the Commission Delegated Regulation (EU) No 134/2014. (See end of Document for details)

96	43,3			X	
97	44,5			X	
98	45,1				X
99	45,1				X
100	43,9				X
101	41,4				X
102	38,4				X
103	35,5				X
104	32,9				X
105	31,3				X
106	30,7				X
107	31,0			X	
108	32,2			X	
109	34,0			X	
110	36,0			X	
111	37,9			X	
112	39,9			X	
113	41,6			X	
114	43,1			X	
115	44,3			X	
116	45,0			X	
117	45,5			X	
118	45,8			X	
119	46,0			X	
120	46,1			X	
121	46,2			X	
122	46,1			X	
123	45,7			X	
124	45,0			X	
125	44,3			X	
126	44,7		X		
127	46,8		X		
128	50,1		X		

Status: Point in time view as at 16/12/2013.

Changes to legislation: There are currently no known outstanding effects for the Commission Delegated Regulation (EU) No 134/2014. (See end of Document for details)

129	53,6		X		
130	56,9		X		
131	59,4		X		
132	60,2				X
133	59,3				X
134	57,5				X
135	55,4				X
136	52,5				X
137	47,9				X
138	41,4				X
139	34,4				X
140	30,0				X
141	27,0				X
142	26,5		X		
143	28,7		X		
144	33,8		X		
145	40,3		X		
146	46,6		X		
147	50,4		X		
148	54,0		X		
149	56,9		X		
150	59,1		X		
151	60,6		X		
152	61,7		X		
153	62,6		X		
154	63,1				X
155	62,9				X
156	61,7				X
157	59,4				X
158	56,6				X
159	53,7				X
160	50,7				X
161	47,7				X
162	45,0				X

Status: Point in time view as at 16/12/2013.

Changes to legislation: There are currently no known outstanding effects for the Commission Delegated Regulation (EU) No 134/2014. (See end of Document for details)

163	43,1				X
164	41,9			X	
165	41,6			X	
166	41,3			X	
167	40,9			X	
168	41,8			X	
169	42,1			X	
170	41,8			X	
171	41,3			X	
172	41,5		X		
173	43,5		X		
174	46,5		X		
175	49,7		X		
176	52,6		X		
177	55,0		X		
178	56,5		X		
179	57,1		X		
180	57,3				X

3.1.6.

TABLE AP6-16

WMTC stage 2, cycle part 2 for vehicle classes 2-2 and 3, 181 to 360 s

time in s	roller speed in km/h	phase indicators			
		stop	acc	cruise	dec
181	57,0				X
182	56,3				X
183	55,2				X
184	53,9				X
185	52,6				X
186	51,4				X
187	50,1		X		
188	51,5		X		
189	53,1		X		
190	54,8		X		
191	56,6		X		

Status: Point in time view as at 16/12/2013.

Changes to legislation: There are currently no known outstanding effects for the Commission Delegated Regulation (EU) No 134/2014. (See end of Document for details)

192	58,5		X		
193	60,6		X		
194	62,8		X		
195	64,9		X		
196	67,0		X		
197	69,1		X		
198	70,9		X		
199	72,2		X		
200	72,8				X
201	72,8				X
202	71,9				X
203	70,5				X
204	68,8				X
205	67,1				X
206	65,4				X
207	63,9				X
208	62,8				X
209	61,8				X
210	61,0				X
211	60,4				X
212	60,0				X
213	60,2			X	
214	61,4			X	
215	63,3			X	
216	65,5			X	
217	67,4			X	
218	68,5			X	
219	68,7				X
220	68,1				X
221	67,3				X
222	66,5				X
223	65,9				X
224	65,5				X
225	64,9				X

LIST OF ANNEXES

Document Generated: 2023-10-14

Status: Point in time view as at 16/12/2013.**Changes to legislation:** There are currently no known outstanding effects for the Commission Delegated Regulation (EU) No 134/2014. (See end of Document for details)

226	64,1				X
227	63,0				X
228	62,1				X
229	61,6		X		
230	61,7		X		
231	62,3		X		
232	63,5		X		
233	65,3		X		
234	67,3		X		
235	69,3		X		
236	71,4		X		
237	73,5		X		
238	75,6		X		
239	77,7		X		
240	79,7		X		
241	81,5		X		
242	83,1		X		
243	84,6		X		
244	86,0		X		
245	87,4		X		
246	88,7		X		
247	89,6		X		
248	90,2		X		
249	90,7		X		
250	91,2		X		
251	91,8		X		
252	92,4		X		
253	93,0		X		
254	93,6		X		
255	94,1			X	
256	94,3			X	
257	94,4			X	
258	94,4			X	
259	94,3			X	

Status: Point in time view as at 16/12/2013.

Changes to legislation: There are currently no known outstanding effects for the Commission Delegated Regulation (EU) No 134/2014. (See end of Document for details)

260	94,3			X	
261	94,2			X	
262	94,2			X	
263	94,2			X	
264	94,1			X	
265	94,0			X	
266	94,0			X	
267	93,9			X	
268	93,9			X	
269	93,9			X	
270	93,9			X	
271	93,9			X	
272	94,0			X	
273	94,0			X	
274	94,1			X	
275	94,2			X	
276	94,3			X	
277	94,4			X	
278	94,5			X	
279	94,5			X	
280	94,5			X	
281	94,5			X	
282	94,4			X	
283	94,5			X	
284	94,6			X	
285	94,7			X	
286	94,8			X	
287	94,9			X	
288	94,8			X	
289	94,3				X
290	93,3				X
291	91,8				X
292	89,6				X
293	87,0				X

Status: Point in time view as at 16/12/2013.

Changes to legislation: There are currently no known outstanding effects for the Commission Delegated Regulation (EU) No 134/2014. (See end of Document for details)

294	84,1				X
295	81,2				X
296	78,4				X
297	75,7				X
298	73,2				X
299	71,1				X
300	69,5				X
301	68,3				X
302	67,3				X
303	66,1				X
304	63,9				X
305	60,2				X
306	54,9				X
307	48,1				X
308	40,9				X
309	36,0				X
310	33,9				X
311	33,9		X		
312	36,5		X		
313	41,0		X		
314	45,3		X		
315	49,2		X		
316	51,5		X		
317	53,2		X		
318	53,9		X		
319	53,9		X		
320	53,7		X		
321	53,7		X		
322	54,3		X		
323	55,4		X		
324	56,8		X		
325	58,1		X		
326	58,9				X
327	58,2				X

Status: Point in time view as at 16/12/2013.

Changes to legislation: There are currently no known outstanding effects for the Commission Delegated Regulation (EU) No 134/2014. (See end of Document for details)

328	55,8				X
329	52,6				X
330	49,2				X
331	47,6		X		
332	48,4		X		
333	51,8		X		
334	55,7		X		
335	59,6		X		
336	63,0		X		
337	65,9		X		
338	68,1		X		
339	69,8		X		
340	71,1		X		
341	72,1		X		
342	72,9		X		
343	73,7		X		
344	74,4		X		
345	75,1		X		
346	75,8		X		
347	76,5		X		
348	77,2		X		
349	77,8		X		
350	78,5		X		
351	79,2		X		
352	80,0		X		
353	81,0		X		
354	82,0		X		
355	83,0		X		
356	83,7		X		
357	84,2			X	
358	84,4			X	
359	84,5			X	
360	84,4			X	

Status: Point in time view as at 16/12/2013.

Changes to legislation: There are currently no known outstanding effects for the Commission Delegated Regulation (EU) No 134/2014. (See end of Document for details)

3.1.7.

TABLE AP6-17

WMTC stage 2, cycle part 2 for vehicle classes 2-2 and 3, 361 to 540 s

time in s	roller speed in km/h	phase indicators			
		stop	acc	cruise	dec
361	84,1			X	
362	83,7			X	
363	83,2			X	
364	82,8			X	
365	82,6			X	
366	82,5			X	
367	82,4			X	
368	82,3			X	
369	82,2			X	
370	82,2			X	
371	82,2			X	
372	82,1			X	
373	81,9			X	
374	81,6			X	
375	81,3			X	
376	81,1			X	
377	80,8			X	
378	80,6			X	
379	80,4			X	
380	80,1			X	
381	79,7				X
382	78,6				X
383	76,8				X
384	73,7				X
385	69,4				X
386	64,0				X
387	58,6				X
388	53,2				X
389	47,8				X
390	42,4				X

Status: Point in time view as at 16/12/2013.

Changes to legislation: There are currently no known outstanding effects for the Commission Delegated Regulation (EU) No 134/2014. (See end of Document for details)

391	37,0				X
392	33,0				X
393	30,9				X
394	30,9		X		
395	33,5		X		
396	38,0		X		
397	42,5		X		
398	47,0		X		
399	51,0		X		
400	53,5		X		
401	55,1		X		
402	56,4		X		
403	57,3		X		
404	58,1		X		
405	58,8		X		
406	59,4		X		
407	59,8			X	
408	59,7			X	
409	59,4			X	
410	59,2			X	
411	59,2			X	
412	59,6			X	
413	60,0			X	
414	60,5			X	
415	61,0			X	
416	61,2			X	
417	61,3			X	
418	61,4			X	
419	61,7			X	
420	62,3			X	
421	63,1			X	
422	63,6			X	
423	63,9			X	
424	63,8			X	

Status: Point in time view as at 16/12/2013.

Changes to legislation: There are currently no known outstanding effects for the Commission Delegated Regulation (EU) No 134/2014. (See end of Document for details)

425	63,6			X	
426	63,3				X
427	62,8				X
428	61,9				X
429	60,5				X
430	58,6				X
431	56,5				X
432	54,6				X
433	53,8			X	
434	54,5			X	
435	56,1			X	
436	57,9			X	
437	59,7			X	
438	61,2			X	
439	62,3			X	
440	63,1			X	
441	63,6				X
442	63,5				X
443	62,7				X
444	60,9				X
445	58,7				X
446	56,4				X
447	54,5				X
448	53,3				X
449	53,0			X	
450	53,5			X	
451	54,6			X	
452	56,1			X	
453	57,6			X	
454	58,9			X	
455	59,8			X	
456	60,3			X	
457	60,7			X	
458	61,3			X	

Status: Point in time view as at 16/12/2013.

Changes to legislation: There are currently no known outstanding effects for the Commission Delegated Regulation (EU) No 134/2014. (See end of Document for details)

459	62,4			X	
460	64,1			X	
461	66,2			X	
462	68,1			X	
463	69,7			X	
464	70,4			X	
465	70,7			X	
466	70,7			X	
467	70,7			X	
468	70,7			X	
469	70,6			X	
470	70,5			X	
471	70,4			X	
472	70,2			X	
473	70,1			X	
474	69,8			X	
475	69,5			X	
476	69,1			X	
477	69,1			X	
478	69,5			X	
479	70,3			X	
480	71,2			X	
481	72,0			X	
482	72,6			X	
483	72,8			X	
484	72,7			X	
485	72,0				X
486	70,4				X
487	67,7				X
488	64,4				X
489	61,0				X
490	57,6				X
491	54,0				X
492	49,7				X

Status: Point in time view as at 16/12/2013.

Changes to legislation: There are currently no known outstanding effects for the Commission Delegated Regulation (EU) No 134/2014. (See end of Document for details)

493	44,4				X
494	38,2				X
495	31,2				X
496	24,0				X
497	16,8				X
498	10,4				X
499	5,7				X
500	2,8				X
501	1,6				X
502	0,3				X
503	0,0	X			
504	0,0	X			
505	0,0	X			
506	0,0	X			
507	0,0	X			
508	0,0	X			
509	0,0	X			
510	0,0	X			
511	0,0	X			
512	0,0	X			
513	0,0	X			
514	0,0	X			
515	0,0	X			
516	0,0	X			
517	0,0	X			
518	0,0	X			
519	0,0	X			
520	0,0	X			
521	0,0	X			
522	0,0	X			
523	0,0	X			
524	0,0	X			
525	0,0	X			
526	0,0	X			

Status: Point in time view as at 16/12/2013.

Changes to legislation: There are currently no known outstanding effects for the Commission Delegated Regulation (EU) No 134/2014. (See end of Document for details)

527	0,0	X			
528	0,0	X			
529	0,0	X			
530	0,0	X			
531	0,0	X			
532	0,0	X			
533	2,3		X		
534	7,2		X		
535	14,6		X		
536	23,5		X		
537	33,0		X		
538	42,7		X		
539	51,8		X		
540	59,4		X		

3.1.8.

TABLE AP6-18

WMTC stage 2, cycle part 2 for vehicle classes 2-2 and 3, 541 to 600 s

time in s	roller speed in km/h	phase indicators			
		stop	acc	cruise	dec
541	65,3		X		
542	69,6		X		
543	72,3		X		
544	73,9		X		
545	75,0		X		
546	75,7		X		
547	76,5		X		
548	77,3		X		
549	78,2		X		
550	78,9		X		
551	79,4			X	
552	79,6			X	
553	79,3			X	
554	78,8			X	
555	78,1			X	
556	77,5			X	

LIST OF ANNEXES

Document Generated: 2023-10-14

Status: Point in time view as at 16/12/2013.**Changes to legislation:** There are currently no known outstanding effects for the Commission Delegated Regulation (EU) No 134/2014. (See end of Document for details)

557	77,2			X	
558	77,2			X	
559	77,5			X	
560	77,9			X	
561	78,5			X	
562	79,1			X	
563	79,6			X	
564	80,0			X	
565	80,2			X	
566	80,3			X	
567	80,1			X	
568	79,8			X	
569	79,5			X	
570	79,1			X	
571	78,8			X	
572	78,6			X	
573	78,4			X	
574	78,3			X	
575	78,0				X
576	76,7				X
577	73,7				X
578	69,5				X
579	64,8				X
580	60,3				X
581	56,2				X
582	52,5				X
583	49,0				X
584	45,2				X
585	40,8				X
586	35,4				X
587	29,4				X
588	23,4				X
589	17,7				X
590	12,6				X

Status: Point in time view as at 16/12/2013.

Changes to legislation: There are currently no known outstanding effects for the Commission Delegated Regulation (EU) No 134/2014. (See end of Document for details)

591	8,0				X
592	4,1				X
593	1,3				X
594	0,0	X			
595	0,0	X			
596	0,0	X			
597	0,0	X			
598	0,0	X			
599	0,0	X			
600	0,0	X			

4. WMTC stage 2, part 3

Figure Ap6-8

WMTC stage 2, part 3

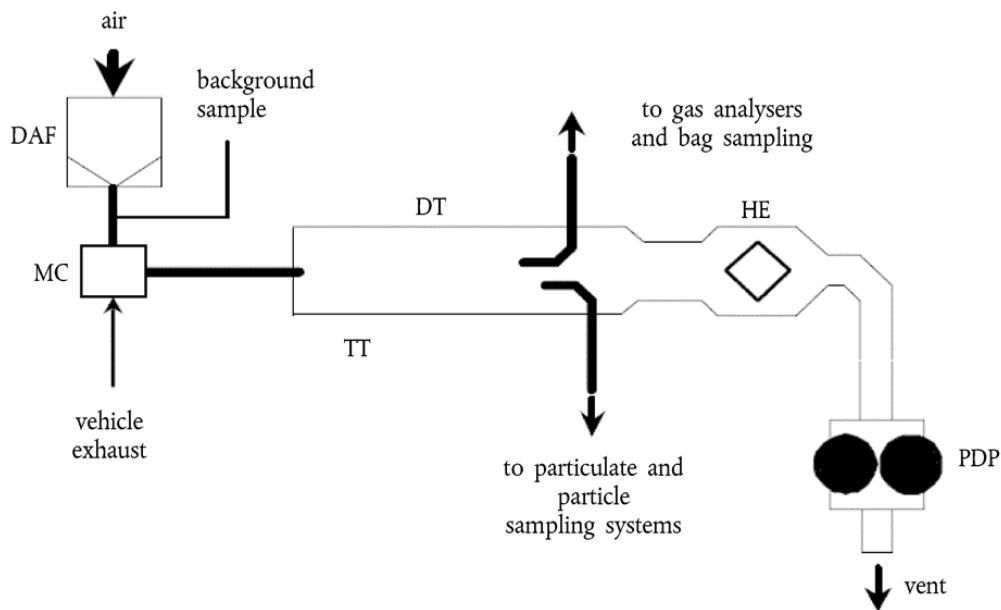

4.1 The WMTC stage 2 includes the same vehicle speed trace as WMTC stage 1 with supplemental gear shift prescriptions. The characteristic roller speed versus test time of WMTC stage 2, part 3 is set out in the following tables.

4.1.1.

TABLE AP6-19

WMTC stage 2, cycle part 3, reduced speed for vehicle class 3-1, 1 to 180 s

time in s	roller speed in km/h	phase indicators			
		stop	acc	cruise	dec
0	0,0	X			

Status: Point in time view as at 16/12/2013.

Changes to legislation: There are currently no known outstanding effects for the Commission Delegated Regulation (EU) No 134/2014. (See end of Document for details)

1	0,0	X			
2	0,0	X			
3	0,0	X			
4	0,0	X			
5	0,0	X			
6	0,0	X			
7	0,0	X			
8	0,9		X		
9	3,2		X		
10	7,3		X		
11	12,4		X		
12	17,9		X		
13	23,5		X		
14	29,1		X		
15	34,3		X		
16	38,6		X		
17	41,6		X		
18	43,9		X		
19	45,9		X		
20	48,1		X		
21	50,3		X		
22	52,6		X		
23	54,8		X		
24	55,8		X		
25	55,2		X		
26	53,9		X		
27	52,7		X		
28	52,8		X		
29	55,0		X		
30	58,5		X		
31	62,3		X		
32	65,7		X		
33	68,1		X		
34	69,1		X		

Status: Point in time view as at 16/12/2013.

Changes to legislation: There are currently no known outstanding effects for the Commission Delegated Regulation (EU) No 134/2014. (See end of Document for details)

35	69,5		X		
36	69,9		X		
37	70,6		X		
38	71,3		X		
39	72,2		X		
40	72,8		X		
41	73,2		X		
42	73,4		X		
43	73,8		X		
44	74,8		X		
45	76,7		X		
46	79,1		X		
47	81,1		X		
48	82,1				X
49	81,7				X
50	80,3				X
51	78,8				X
52	77,3				X
53	75,9				X
54	75,0				X
55	74,7				X
56	74,7				X
57	74,7				X
58	74,6				X
59	74,4				X
60	74,1				X
61	73,9				X
62	74,1		X		
63	75,1		X		
64	76,8		X		
65	78,7		X		
66	80,4		X		
67	81,7		X		
68	82,6		X		

LIST OF ANNEXES

Document Generated: 2023-10-14

Status: Point in time view as at 16/12/2013.

Changes to legislation: There are currently no known outstanding effects for the Commission Delegated Regulation (EU) No 134/2014. (See end of Document for details)

69	83,5		X		
70	84,4		X		
71	85,1		X		
72	85,7		X		
73	86,3		X		
74	87,0		X		
75	87,9		X		
76	88,8		X		
77	89,7		X		
78	90,3			X	
79	90,6			X	
80	90,6			X	
81	90,5			X	
82	90,4			X	
83	90,1			X	
84	89,7			X	
85	89,3			X	
86	89,0			X	
87	88,8			X	
88	88,9			X	
89	89,1			X	
90	89,3			X	
91	89,4			X	
92	89,4			X	
93	89,2			X	
94	88,9			X	
95	88,5			X	
96	88,0			X	
97	87,5			X	
98	87,2			X	
99	87,1			X	
100	87,2			X	
101	87,3			X	
102	87,4			X	

Status: Point in time view as at 16/12/2013.

Changes to legislation: There are currently no known outstanding effects for the Commission Delegated Regulation (EU) No 134/2014. (See end of Document for details)

103	87,5			X	
104	87,4			X	
105	87,1			X	
106	86,8			X	
107	86,4			X	
108	85,9			X	
109	85,2				X
110	84,0				X
111	82,2				X
112	80,3				X
113	78,6				X
114	77,2				X
115	75,9				X
116	73,8				X
117	70,4				X
118	65,7				X
119	60,5				X
120	55,9				X
121	53,0				X
122	51,6				X
123	50,9				X
124	50,5				X
125	50,2				X
126	50,3		X		
127	50,6		X		
128	51,2		X		
129	51,8		X		
130	52,5		X		
131	53,4		X		
132	54,9		X		
133	57,0		X		
134	59,4		X		
135	61,9		X		

Status: Point in time view as at 16/12/2013.

Changes to legislation: There are currently no known outstanding effects for the Commission Delegated Regulation (EU) No 134/2014. (See end of Document for details)

136	64,3		X		
137	66,4		X		
138	68,1		X		
139	69,6		X		
140	70,7		X		
141	71,4		X		
142	71,8		X		
143	72,8		X		
144	75,0		X		
145	77,8		X		
146	80,7		X		
147	83,3		X		
148	75,4		X		
149	87,3		X		
150	89,1		X		
151	90,6		X		
152	91,9		X		
153	93,2		X		
154	94,6		X		
155	96,0		X		
156	97,5		X		
157	99,0		X		
158	99,8				X
159	99,0				X
160	96,7				X
161	93,7				X
162	91,3				X
163	90,4				X
164	90,6				X
165	91,1				X
166	90,9				X
167	89,0				X
168	85,6				X
169	81,6				X

Status: Point in time view as at 16/12/2013.

Changes to legislation: There are currently no known outstanding effects for the Commission Delegated Regulation (EU) No 134/2014. (See end of Document for details)

170	77,6				X
171	73,6				X
172	69,7				X
173	66,0				X
174	62,7				X
175	60,0				X
176	58,0				X
177	56,4				X
178	54,8				X
179	53,3				X
180	51,7				X

4.1.2.

TABLE AP6-20

WMTC stage 2, cycle part 3, reduced speed for vehicle class 3-1, 181 to 360 s

time in s	roller speed in km/h	phase indicators			
		stop	acc	cruise	dec
181	50,2				X
182	48,7				X
183	47,2			X	
184	47,1			X	
185	47,0			X	
186	46,9			X	
187	46,6			X	
188	46,3			X	
189	46,1			X	
190	46,1		X		
191	46,5		X		
192	47,1		X		
193	48,1		X		
194	49,8		X		
195	52,2		X		
196	54,8		X		
197	57,3		X		
198	59,5		X		

LIST OF ANNEXES

Document Generated: 2023-10-14

Status: Point in time view as at 16/12/2013.**Changes to legislation:** There are currently no known outstanding effects for the Commission Delegated Regulation (EU) No 134/2014. (See end of Document for details)

199	61,7		X		
200	64,4		X		
201	67,7		X		
202	71,4		X		
203	74,9		X		
204	78,2		X		
205	81,1		X		
206	83,9		X		
207	86,6		X		
208	89,1		X		
209	91,6		X		
210	94,0		X		
211	96,3		X		
212	98,4		X		
213	100,4		X		
214	102,1		X		
215	103,6		X		
216	104,9		X		
217	106,2			X	
218	106,5			X	
219	106,5			X	
220	106,6			X	
221	106,6			X	
222	107,0			X	
223	107,3			X	
224	107,3			X	
225	107,2			X	
226	107,2			X	
227	107,2			X	
228	107,3			X	
229	107,5			X	
230	107,3			X	
231	107,3			X	
232	107,3			X	

Status: Point in time view as at 16/12/2013.

Changes to legislation: There are currently no known outstanding effects for the Commission Delegated Regulation (EU) No 134/2014. (See end of Document for details)

233	107,3			X	
234	108,0			X	
235	108,2			X	
236	108,9			X	
237	109,0			X	
238	108,9			X	
239	108,8			X	
240	108,6			X	
241	108,4			X	
242	108,3			X	
243	108,2			X	
244	108,2			X	
245	108,2			X	
246	108,2			X	
247	108,3			X	
248	108,4			X	
249	108,5			X	
250	108,5			X	
251	108,5			X	
252	108,5			X	
253	108,5			X	
254	108,7			X	
255	108,8			X	
256	109,0			X	
257	109,2			X	
258	109,3			X	
259	109,4			X	
260	109,5			X	
261	109,5			X	
262	109,6			X	
263	109,8			X	
264	110,0			X	
265	110,2			X	
266	110,5			X	

Status: Point in time view as at 16/12/2013.

Changes to legislation: There are currently no known outstanding effects for the Commission Delegated Regulation (EU) No 134/2014. (See end of Document for details)

267	110,7			X	
268	111,0			X	
269	111,1			X	
270	111,2			X	
271	111,3			X	
272	111,3			X	
273	111,3			X	
274	111,2			X	
275	111,0			X	
276	110,8			X	
277	110,6			X	
278	110,4			X	
279	110,3			X	
280	109,9			X	
281	109,3				X
282	108,1				X
283	106,3				X
284	104,0				X
285	101,5				X
286	99,2				X
287	97,2				X
288	96,1				X
289	95,7			X	
290	95,8			X	
291	96,1			X	
292	96,4			X	
293	96,7			X	
294	96,9			X	
295	96,9			X	
296	96,8			X	
297	96,7			X	
298	96,4			X	
299	96,1			X	
300	95,9			X	

Status: Point in time view as at 16/12/2013.

Changes to legislation: There are currently no known outstanding effects for the Commission Delegated Regulation (EU) No 134/2014. (See end of Document for details)

301	95,8			X	
302	95,9			X	
303	96,2			X	
304	96,4			X	
305	96,7			X	
306	96,7			X	
307	96,3			X	
308	95,3				X
309	94,0				X
310	92,5				X
311	91,4				X
312	90,9				X
313	90,7				X
314	90,3				X
315	89,6				X
316	88,6				X
317	87,7				X
318	86,8				X
319	86,2				X
320	85,8				X
321	85,7				X
322	85,7				X
323	86,0			X	
324	86,7			X	
325	87,8			X	
326	89,2			X	
327	90,9			X	
328	92,6			X	
329	94,3			X	
330	95,9			X	
331	97,4			X	
332	98,7			X	
333	99,7			X	
334	100,3			X	

Status: Point in time view as at 16/12/2013.

Changes to legislation: There are currently no known outstanding effects for the Commission Delegated Regulation (EU) No 134/2014. (See end of Document for details)

335	100,6			X	
336	101,0			X	
337	101,4			X	
338	101,8			X	
339	102,2			X	
340	102,5			X	
341	102,6			X	
342	102,7			X	
343	102,8			X	
344	103,0			X	
345	103,5			X	
346	104,3			X	
347	105,2			X	
348	106,1			X	
349	106,8			X	
350	107,1				X
351	106,7				X
352	105,0				X
353	102,3				X
354	99,1				X
355	96,3				X
356	95,0				X
357	95,4				X
358	96,4				X
359	97,3				X
360	97,5				X

4.1.3.

TABLE AP6-21

WMTC stage 2, cycle part 3, reduced speed for vehicle class 3-1, 361 to 540 s

time in s	roller speed in km/h	phase indicators			
		stop	acc	cruise	dec
361	96,1				X
362	93,4				X
363	90,4				X
364	87,8				X

Status: Point in time view as at 16/12/2013.

Changes to legislation: There are currently no known outstanding effects for the Commission Delegated Regulation (EU) No 134/2014. (See end of Document for details)

365	86,0				X
366	85,1				X
367	84,7				X
368	84,2			X	
369	85,0			X	
370	86,5			X	
371	88,3			X	
372	89,9			X	
373	91,0			X	
374	91,8			X	
375	92,5			X	
376	93,1			X	
377	93,7			X	
378	94,4			X	
379	95,0			X	
380	95,6			X	
381	96,3			X	
382	96,9			X	
383	97,5			X	
384	98,0			X	
385	98,3			X	
386	98,6			X	
387	98,9			X	
388	99,1			X	
389	99,3			X	
390	99,3			X	
391	99,2			X	
392	99,2			X	
393	99,3			X	
394	99,5			X	
395	99,9			X	
396	100,3			X	
397	100,6			X	
398	100,9			X	

LIST OF ANNEXES

Document Generated: 2023-10-14

Status: Point in time view as at 16/12/2013.**Changes to legislation:** There are currently no known outstanding effects for the Commission Delegated Regulation (EU) No 134/2014. (See end of Document for details)

399	101,1			X	
400	101,3			X	
401	101,4			X	
402	101,5			X	
403	101,6			X	
404	101,8			X	
405	101,9			X	
406	102,0			X	
407	102,0			X	
408	102,0			X	
409	102,0			X	
410	101,9			X	
411	101,9			X	
412	101,9			X	
413	101,8			X	
414	101,8			X	
415	101,8			X	
416	101,8			X	
417	101,8			X	
418	101,8			X	
419	101,9			X	
420	102,0			X	
421	102,2			X	
422	102,4			X	
423	102,6			X	
424	102,8			X	
425	103,1			X	
426	103,4			X	
427	103,9			X	
428	104,4			X	
429	104,9			X	
430	105,2			X	
431	105,5			X	
432	105,7			X	

Status: Point in time view as at 16/12/2013.

Changes to legislation: There are currently no known outstanding effects for the Commission Delegated Regulation (EU) No 134/2014. (See end of Document for details)

433	105,9			X	
434	106,1			X	
435	106,3			X	
436	106,5			X	
437	106,8			X	
438	107,1			X	
439	107,5			X	
440	108,0			X	
441	108,3			X	
442	108,6			X	
443	108,9			X	
444	109,1			X	
445	109,2			X	
446	109,4			X	
447	109,5			X	
448	109,7			X	
449	109,9			X	
450	110,2			X	
451	110,5			X	
452	110,8			X	
453	111,0			X	
454	111,2			X	
455	111,3			X	
456	111,1			X	
457	110,4			X	
458	109,3			X	
459	108,1			X	
460	106,8			X	
461	105,5			X	
462	104,4			X	
463	103,8			X	
464	103,6			X	
465	103,5			X	
466	103,5			X	

Status: Point in time view as at 16/12/2013.

Changes to legislation: There are currently no known outstanding effects for the Commission Delegated Regulation (EU) No 134/2014. (See end of Document for details)

467	103,4			X	
468	103,3			X	
469	103,1			X	
470	102,9			X	
471	102,6			X	
472	102,5			X	
473	102,4			X	
474	102,4			X	
475	102,5			X	
476	102,7			X	
477	103,0			X	
478	103,3			X	
479	103,7			X	
480	104,1			X	
481	104,5			X	
482	104,8			X	
483	104,9			X	
484	105,1			X	
485	105,1			X	
486	105,2			X	
487	105,2			X	
488	105,2			X	
489	105,3			X	
490	105,3			X	
491	105,4			X	
492	105,5			X	
493	105,5			X	
494	105,3			X	
495	105,1			X	
496	104,7			X	
497	104,2			X	
498	103,9			X	
499	103,6			X	
500	103,5			X	

Status: Point in time view as at 16/12/2013.

Changes to legislation: There are currently no known outstanding effects for the Commission Delegated Regulation (EU) No 134/2014. (See end of Document for details)

501	103,5			X	
502	103,4			X	
503	103,3			X	
504	103,0			X	
505	102,7			X	
506	102,4			X	
507	102,1			X	
508	101,9			X	
509	101,7			X	
510	101,5			X	
511	101,3			X	
512	101,2			X	
513	101,0			X	
514	100,9			X	
515	100,9			X	
516	101,0			X	
517	101,2			X	
518	101,3			X	
519	101,4			X	
520	101,4			X	
521	101,2			X	
522	100,8			X	
523	100,4			X	
524	99,9			X	
525	99,6			X	
526	99,5			X	
527	99,5			X	
528	99,6			X	
529	99,7			X	
530	99,8			X	
531	99,9			X	
532	100,0			X	
533	100,0			X	
534	100,1			X	

Status: Point in time view as at 16/12/2013.

Changes to legislation: There are currently no known outstanding effects for the Commission Delegated Regulation (EU) No 134/2014. (See end of Document for details)

535	100,2			X	
536	100,4			X	
537	100,5			X	
538	100,6			X	
539	100,7			X	
540	100,8			X	

4.1.4.

TABLE AP6-22

WMTC stage 2, cycle part 3, reduced speed for vehicle class 3-1, 541 to 600 s

time in s	roller speed in km/h	phase indicators			
		stop	acc	cruise	dec
541	101,0			X	
542	101,3			X	
543	102,0			X	
544	102,7			X	
545	103,5			X	
546	104,2			X	
547	104,6			X	
548	104,7			X	
549	104,8			X	
550	104,8			X	
551	104,9			X	
552	105,1			X	
553	105,4			X	
554	105,7			X	
555	105,9			X	
556	106,0			X	
557	105,7				X
558	105,4				X
559	103,9				X
560	102,2				X
561	100,5				X
562	99,2				X
563	98,0				X
564	96,4				X

Status: Point in time view as at 16/12/2013.

Changes to legislation: There are currently no known outstanding effects for the Commission Delegated Regulation (EU) No 134/2014. (See end of Document for details)

565	94,8				X
566	92,8				X
567	88,9				X
568	84,9				X
569	80,6				X
570	76,3				X
571	72,3				X
572	68,7				X
573	65,5				X
574	63,0				X
575	61,2				X
576	60,5				X
577	60,0				X
578	59,7				X
579	59,4				X
580	59,4				X
581	58,0				X
582	55,0				X
583	51,0				X
584	46,0				X
585	38,8				X
586	31,6				X
587	24,4				X
588	17,2				X
589	10,0				X
590	5,0				X
591	2,0				X
592	0,0	X			
593	0,0	X			
594	0,0	X			
595	0,0	X			
596	0,0	X			
597	0,0	X			
598	0,0	X			

Status: Point in time view as at 16/12/2013.

Changes to legislation: There are currently no known outstanding effects for the Commission Delegated Regulation (EU) No 134/2014. (See end of Document for details)

599	0,0	X			
600	0,0	X			

4.1.5.

TABLE AP6-23

WMTC stage 2, cycle part 3 for vehicle class 3-2, 0 to 180 s

time in s	roller speed in km/h	phase indicators			
		stop	acc	cruise	dec
0	0,0	X			
1	0,0	X			
2	0,0	X			
3	0,0	X			
4	0,0	X			
5	0,0	X			
6	0,0	X			
7	0,0	X			
8	0,9		X		
9	3,2		X		
10	7,3		X		
11	12,4		X		
12	17,9		X		
13	23,5		X		
14	29,1		X		
15	34,3		X		
16	38,6		X		
17	41,6		X		
18	43,9		X		
19	45,9		X		
20	48,1		X		
21	50,3		X		
22	52,6		X		
23	54,8		X		
24	55,8		X		
25	55,2		X		
26	53,9		X		
27	52,7		X		

Status: Point in time view as at 16/12/2013.

Changes to legislation: There are currently no known outstanding effects for the Commission Delegated Regulation (EU) No 134/2014. (See end of Document for details)

28	52,8		X		
29	55,0		X		
30	58,5		X		
31	62,3		X		
32	65,7		X		
33	68,1		X		
34	69,1		X		
35	69,5		X		
36	69,9		X		
37	70,6		X		
38	71,3		X		
39	72,2		X		
40	72,8		X		
41	73,2		X		
42	73,4		X		
43	73,8		X		
44	74,8		X		
45	76,7		X		
46	79,1		X		
47	81,1		X		
48	82,1				X
49	81,7				X
50	80,3				X
51	78,8				X
52	77,3				X
53	75,9				X
54	75,0				X
55	74,7				X
56	74,7				X
57	74,7				X
58	74,6				X
59	74,4				X
60	74,1				X
61	73,9				X

LIST OF ANNEXES

Document Generated: 2023-10-14

Status: Point in time view as at 16/12/2013.**Changes to legislation:** There are currently no known outstanding effects for the Commission Delegated Regulation (EU) No 134/2014. (See end of Document for details)

62	74,1		X		
63	75,1		X		
64	76,8		X		
65	78,7		X		
66	80,4		X		
67	81,7		X		
68	82,6		X		
69	83,5		X		
70	84,4		X		
71	85,1		X		
72	85,7		X		
73	86,3		X		
74	87,0		X		
75	87,9		X		
76	88,8		X		
77	89,7		X		
78	90,3			X	
79	90,6			X	
80	90,6			X	
81	90,5			X	
82	90,4			X	
83	90,1			X	
84	89,7			X	
85	89,3			X	
86	89,0			X	
87	88,8			X	
88	88,9			X	
89	89,1			X	
90	89,3			X	
91	89,4			X	
92	89,4			X	
93	89,2			X	
94	88,9			X	
95	88,5			X	

Status: Point in time view as at 16/12/2013.

Changes to legislation: There are currently no known outstanding effects for the Commission Delegated Regulation (EU) No 134/2014. (See end of Document for details)

96	88,0			X	
97	87,5			X	
98	87,2			X	
99	87,1			X	
100	87,2			X	
101	87,3			X	
102	87,4			X	
103	87,5			X	
104	87,4			X	
105	87,1			X	
106	86,8			X	
107	86,4			X	
108	85,9			X	
109	85,2				X
110	84,0				X
111	82,2				X
112	80,3				X
113	78,6				X
114	77,2				X
115	75,9				X
116	73,8				X
117	70,4				X
118	65,7				X
119	60,5				X
120	55,9				X
121	53,0				X
122	51,6				X
123	50,9				X
124	50,5				X
125	50,2				X
126	50,3		X		
127	50,6		X		
128	51,2		X		

LIST OF ANNEXES

Document Generated: 2023-10-14

Status: Point in time view as at 16/12/2013.**Changes to legislation:** There are currently no known outstanding effects for the Commission Delegated Regulation (EU) No 134/2014. (See end of Document for details)

129	51,8		X		
130	52,5		X		
131	53,4		X		
132	54,9		X		
133	57,0		X		
134	59,4		X		
135	61,9		X		
136	64,3		X		
137	66,4		X		
138	68,1		X		
139	69,6		X		
140	70,7		X		
141	71,4		X		
142	71,8		X		
143	72,8		X		
144	75,0		X		
145	77,8		X		
146	80,7		X		
147	83,3		X		
148	85,4		X		
149	87,3		X		
150	89,1		X		
151	90,6		X		
152	91,9		X		
153	93,2		X		
154	94,6		X		
155	96,0		X		
156	97,5		X		
157	99,0		X		
158	99,8				X
159	99,0				X
160	96,7				X
161	93,7				X
162	91,3				X

Status: Point in time view as at 16/12/2013.

Changes to legislation: There are currently no known outstanding effects for the Commission Delegated Regulation (EU) No 134/2014. (See end of Document for details)

163	90,4				X
164	90,6				X
165	91,1				X
166	90,9				X
167	89,0				X
168	85,6				X
169	81,6				X
170	77,6				X
171	73,6				X
172	69,7				X
173	66,0				X
174	62,7				X
175	60,0				X
176	58,0				X
177	56,4				X
178	54,8				X
179	53,3				X
180	51,7				X

4.1.6.

TABLE AP6-24

WMTC stage 2, cycle part 3 for vehicle class 3-2, 181 to 360 s

time in s	roller speed in km/h	phase indicators			
		stop	acc	cruise	dec
181	50,2				X
182	48,7				X
183	47,2			X	
184	47,1			X	
185	47,0			X	
186	46,9			X	
187	46,6			X	
188	46,3			X	
189	46,1			X	
190	46,1		X		
191	46,5		X		

Status: Point in time view as at 16/12/2013.

Changes to legislation: There are currently no known outstanding effects for the Commission Delegated Regulation (EU) No 134/2014. (See end of Document for details)

192	47,1		X		
193	48,1		X		
194	49,8		X		
195	52,2		X		
196	54,8		X		
197	57,3		X		
198	59,5		X		
199	61,7		X		
200	64,4		X		
201	67,7		X		
202	71,4		X		
203	74,9		X		
204	78,2		X		
205	81,1		X		
206	83,9		X		
207	86,6		X		
208	89,1		X		
209	91,6		X		
210	94,0		X		
211	96,3		X		
212	98,4		X		
213	100,4		X		
214	102,1		X		
215	103,6		X		
216	104,9		X		
217	106,2		X		
218	107,5		X		
219	108,5		X		
220	109,3		X		
221	109,9		X		
222	110,5		X		
223	110,9		X		
224	111,2		X		
225	111,4		X		

Status: Point in time view as at 16/12/2013.

Changes to legislation: There are currently no known outstanding effects for the Commission Delegated Regulation (EU) No 134/2014. (See end of Document for details)

226	111,7		X		
227	111,9		X		
228	112,3		X		
229	113,0		X		
230	114,1		X		
231	115,7		X		
232	117,5		X		
233	119,3		X		
234	121,0		X		
235	122,2			X	
236	122,9			X	
237	123,0			X	
238	122,9			X	
239	122,8			X	
240	122,6			X	
241	122,4			X	
242	122,3			X	
243	122,2			X	
244	122,2			X	
245	122,2			X	
246	122,2			X	
247	122,3			X	
248	122,4			X	
249	122,5			X	
250	122,5			X	
251	122,5			X	
252	122,5			X	
253	122,5			X	
254	122,7			X	
255	122,8			X	
256	123,0			X	
257	123,2			X	
258	123,3			X	
259	123,4			X	

Status: Point in time view as at 16/12/2013.

Changes to legislation: There are currently no known outstanding effects for the Commission Delegated Regulation (EU) No 134/2014. (See end of Document for details)

260	123,5			X	
261	123,5			X	
262	123,6			X	
263	123,8			X	
264	124,0			X	
265	124,2			X	
266	124,5			X	
267	124,7			X	
268	125,0			X	
269	125,1			X	
270	125,2			X	
271	125,3			X	
272	125,3			X	
273	125,3			X	
274	125,2			X	
275	125,0			X	
276	124,8			X	
277	124,6			X	
278	124,4			X	
279	124,3			X	
280	123,9			X	
281	123,3				X
282	122,1				X
283	120,3				X
284	118,0				X
285	115,5				X
286	113,2				X
287	111,2				X
288	110,1				X
289	109,7			X	
290	109,8			X	
291	110,1			X	
292	110,4			X	
293	110,7			X	

Status: Point in time view as at 16/12/2013.

Changes to legislation: There are currently no known outstanding effects for the Commission Delegated Regulation (EU) No 134/2014. (See end of Document for details)

294	110,9			X	
295	110,9			X	
296	110,8			X	
297	110,7			X	
298	110,4			X	
299	110,1			X	
300	109,9			X	
301	109,8			X	
302	109,9			X	
303	110,2			X	
304	110,4			X	
305	110,7			X	
306	110,7			X	
307	110,3			X	
308	109,3				X
309	108,0				X
310	106,5				X
311	105,4				X
312	104,9				X
313	104,7				X
314	104,3				X
315	103,6				X
316	102,6				X
317	101,7				X
318	100,8				X
319	100,2				X
320	99,8				X
321	99,7				X
322	99,7				X
323	100,0			X	
324	100,7			X	
325	101,8			X	
326	103,2			X	
327	104,9			X	

Status: Point in time view as at 16/12/2013.

Changes to legislation: There are currently no known outstanding effects for the Commission Delegated Regulation (EU) No 134/2014. (See end of Document for details)

328	106,6			X	
329	108,3			X	
330	109,9			X	
331	111,4			X	
332	112,7			X	
333	113,7			X	
334	114,3			X	
335	114,6			X	
336	115,0			X	
337	115,4			X	
338	115,8			X	
339	116,2			X	
340	116,5			X	
341	116,6			X	
342	116,7			X	
343	116,8			X	
344	117,0			X	
345	117,5			X	
346	118,3			X	
347	119,2			X	
348	120,1			X	
349	120,8			X	
350	121,1				X
351	120,7				X
352	119,0				X
353	116,3				X
354	113,1				X
355	110,3				X
356	109,0				X
357	109,4				X
358	110,4				X
359	111,3				X
360	111,5				X

Status: Point in time view as at 16/12/2013.

Changes to legislation: There are currently no known outstanding effects for the Commission Delegated Regulation (EU) No 134/2014. (See end of Document for details)

4.1.7.

TABLE AP6-25

WMTC stage 2, cycle part 3 for vehicle class 3-2, 361 to 540 s

time in s	roller speed in km/h	phase indicators			
		stop	acc	cruise	dec
361	110,1				X
362	107,4				X
363	104,4				X
364	101,8				X
365	100,0				X
366	99,1				X
367	98,7				X
368	98,2			X	
369	99,0			X	
370	100,5			X	
371	102,3			X	
372	103,9			X	
373	105,0			X	
374	105,8			X	
375	106,5			X	
376	107,1			X	
377	107,7			X	
378	108,4			X	
379	109,0			X	
380	109,6			X	
381	110,3			X	
382	110,9			X	
383	111,5			X	
384	112,0			X	
385	112,3			X	
386	112,6			X	
387	112,9			X	
388	113,1			X	
389	113,3			X	
390	113,3			X	

Status: Point in time view as at 16/12/2013.

Changes to legislation: There are currently no known outstanding effects for the Commission Delegated Regulation (EU) No 134/2014. (See end of Document for details)

391	113,2			X	
392	113,2			X	
393	113,3			X	
394	113,5			X	
395	113,9			X	
396	114,3			X	
397	114,6			X	
398	114,9			X	
399	115,1			X	
400	115,3			X	
401	115,4			X	
402	115,5			X	
403	115,6			X	
404	115,8			X	
405	115,9			X	
406	116,0			X	
407	116,0			X	
408	116,0			X	
409	116,0			X	
410	115,9			X	
411	115,9			X	
412	115,9			X	
413	115,8			X	
414	115,8			X	
415	115,8			X	
416	115,8			X	
417	115,8			X	
418	115,8			X	
419	115,9			X	
420	116,0			X	
421	116,2			X	
422	116,4			X	
423	116,6			X	
424	116,8			X	

Status: Point in time view as at 16/12/2013.

Changes to legislation: There are currently no known outstanding effects for the Commission Delegated Regulation (EU) No 134/2014. (See end of Document for details)

425	117,1			X	
426	117,4			X	
427	117,9			X	
428	118,4			X	
429	118,9			X	
430	119,2			X	
431	119,5			X	
432	119,7			X	
433	119,9			X	
434	120,1			X	
435	120,3			X	
436	120,5			X	
437	120,8			X	
438	121,1			X	
439	121,5			X	
440	122,0			X	
441	122,3			X	
442	122,6			X	
443	122,9			X	
444	123,1			X	
445	123,2			X	
446	123,4			X	
447	123,5			X	
448	123,7			X	
449	123,9			X	
450	124,2			X	
451	124,5			X	
452	124,8			X	
453	125,0			X	
454	125,2			X	
455	125,3			X	
456	125,1			X	
457	124,4			X	
458	123,3			X	

Status: Point in time view as at 16/12/2013.

Changes to legislation: There are currently no known outstanding effects for the Commission Delegated Regulation (EU) No 134/2014. (See end of Document for details)

459	122,1			X	
460	120,8			X	
461	119,5			X	
462	118,4			X	
463	117,8			X	
464	117,6			X	
465	117,5			X	
466	117,5			X	
467	117,4			X	
468	117,3			X	
469	117,1			X	
470	116,9			X	
471	116,6			X	
472	116,5			X	
473	116,4			X	
474	116,4			X	
475	116,5			X	
476	116,7			X	
477	117,0			X	
478	117,3			X	
479	117,7			X	
480	118,1			X	
481	118,5			X	
482	118,8			X	
483	118,9			X	
484	119,1			X	
485	119,1			X	
486	119,2			X	
487	119,2			X	
488	119,2			X	
489	119,3			X	
490	119,3			X	
491	119,4			X	
492	119,5			X	

Status: Point in time view as at 16/12/2013.

Changes to legislation: There are currently no known outstanding effects for the Commission Delegated Regulation (EU) No 134/2014. (See end of Document for details)

493	119,5			X	
494	119,3			X	
495	119,1			X	
496	118,7			X	
497	118,2			X	
498	117,9			X	
499	117,6			X	
500	117,5			X	
501	117,5			X	
502	117,4			X	
503	117,3			X	
504	117,0			X	
505	116,7			X	
506	116,4			X	
507	116,1			X	
508	115,9			X	
509	115,7			X	
510	115,5			X	
511	115,3			X	
512	115,2			X	
513	115,0			X	
514	114,9			X	
515	114,9			X	
516	115,0			X	
517	115,2			X	
518	115,3			X	
519	115,4			X	
520	115,4			X	
521	115,2			X	
522	114,8			X	
523	114,4			X	
524	113,9			X	
525	113,6			X	
526	113,5			X	

Status: Point in time view as at 16/12/2013.

Changes to legislation: There are currently no known outstanding effects for the Commission Delegated Regulation (EU) No 134/2014. (See end of Document for details)

527	113,5			X	
528	113,6			X	
529	113,7			X	
530	113,8			X	
531	113,9			X	
532	114,0			X	
533	114,0			X	
534	114,1			X	
535	114,2			X	
536	114,4			X	
537	114,5			X	
538	114,6			X	
539	114,7			X	
540	114,8			X	

4.1.8.

TABLE AP6-26

WMTC stage 2, cycle part 3 for vehicle class 3-2, 541 to 600 s

time in s	roller speed in km/h	phase indicators			
		stop	acc	cruise	dec
541	115,0			X	
542	115,3			X	
543	116,0			X	
544	116,7			X	
545	117,5			X	
546	118,2			X	
547	118,6			X	
548	118,7			X	
549	118,8			X	
550	118,8			X	
551	118,9			X	
552	119,1			X	
553	119,4			X	
554	119,7			X	
555	119,9			X	
556	120,0			X	

Status: Point in time view as at 16/12/2013.

Changes to legislation: There are currently no known outstanding effects for the Commission Delegated Regulation (EU) No 134/2014. (See end of Document for details)

557	119,7				X
558	118,4				X
559	115,9				X
560	113,2				X
561	110,5				X
562	107,2				X
563	104,0				X
564	100,4				X
565	96,8				X
566	92,8				X
567	88,9				X
568	84,9				X
569	80,6				X
570	76,3				X
571	72,3				X
572	68,7				X
573	65,5				X
574	63,0				X
575	61,2				X
576	60,5				X
577	60,0				X
578	59,7				X
579	59,4				X
580	59,4				X
581	58,0				X
582	55,0				X
583	51,0				X
584	46,0				X
585	38,8				X
586	31,6				X
587	24,4				X
588	17,2				X
589	10,0				X
590	5,0				X

Status: Point in time view as at 16/12/2013.

Changes to legislation: There are currently no known outstanding effects for the Commission Delegated Regulation (EU) No 134/2014. (See end of Document for details)

591	2,0				X
592	0,0	X			
593	0,0	X			
594	0,0	X			
595	0,0	X			
596	0,0	X			
597	0,0	X			
598	0,0	X			
599	0,0	X			
600	0,0	X			

(4) **World Harmonised Motorcycle Test Cycle (WMTC) stage 3 (Revised WMTC)**

1. **Description of the WMTC stage 3 test cycle for L3e, L4e, L5e-A, L7e-A, L7e-B and L7e-C (sub-)category vehicles**

The WMTC stage 3 to be used on the chassis dynamometer shall be as depicted in the following graph for (sub-)category L3e, L4e, L5e-A, L7e-A, L7e-B and L7e-C vehicles:

Figure Ap6-9

WMTC stage 3 for L3e, L4e, L5e-A, L7e-A, L7e-B and L7e-C category vehicles

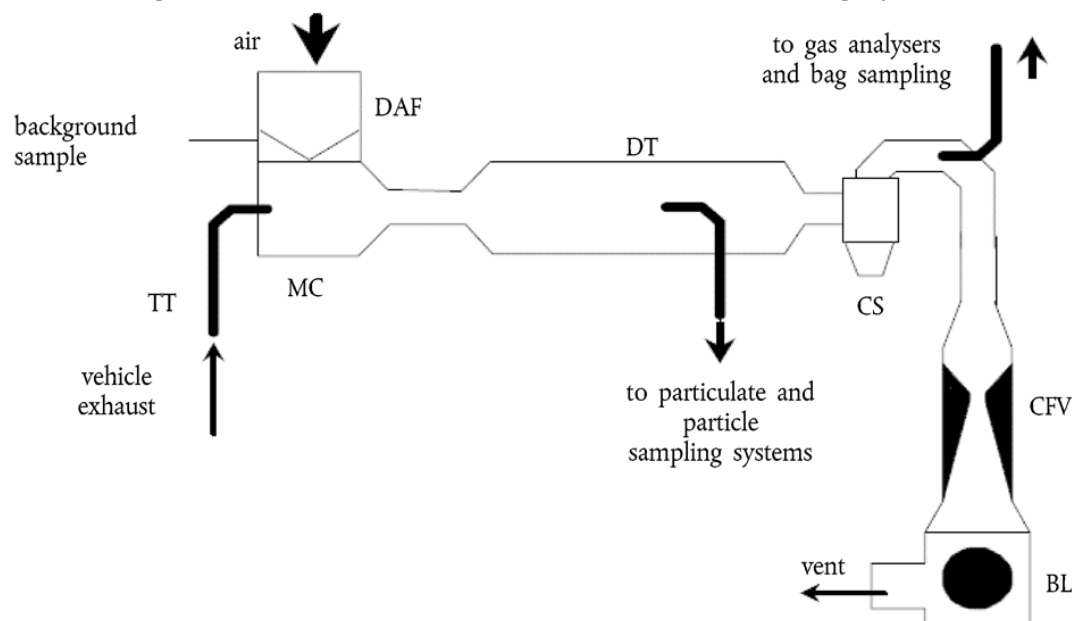

The 'revised WMTC' also referred to as 'WMTC stage 3' as shown in Figure Ap 6-9 is applicable for L3e, L4e, L5e-A, L7e-A, L7e-B and L7e-C vehicles and the vehicle speed trace of WMTC stage 3 is equivalent to WMTC stages 1 and 2. The WMTC stage 3 lasts 1 800 seconds and consists of two parts for vehicles with a low maximum design vehicle speed and three parts for the other L-category vehicles to be carried out without interruption if allowed by maximum vehicle speed limitation. The characteristic driving conditions (idling, acceleration,

Status: Point in time view as at 16/12/2013.

Changes to legislation: There are currently no known outstanding effects for the Commission Delegated Regulation (EU) No 134/2014. (See end of Document for details)

steady speed, deceleration, etc.) of WMTC stage 3 are laid down in chapter 3, which sets out the detailed vehicle speed trace of the WMTC stage 2.

2. Description of the WMTC stage 3 for L1e-A, L1e-B, L2e, L5e-B, L6e-A and L6e-B (sub-)category vehicles

The WMTC stage 3 to be used on the chassis dynamometer shall be as depicted in the following graph for (sub-)category L1e-A, L1e-B, L2e, L6e-A and L6e-B vehicles with a low maximum vehicle design speed:

Figure Ap6-10

WMTC stage 3 for L1e-A, L1e-B, L2e, L5e-B, L6e-A and L6e-B vehicles. The truncated vehicle speed trace limited to 25 km/h is applicable for L1e-A and L1e-B vehicles with a limited maximum design vehicle speed of 25 km/h

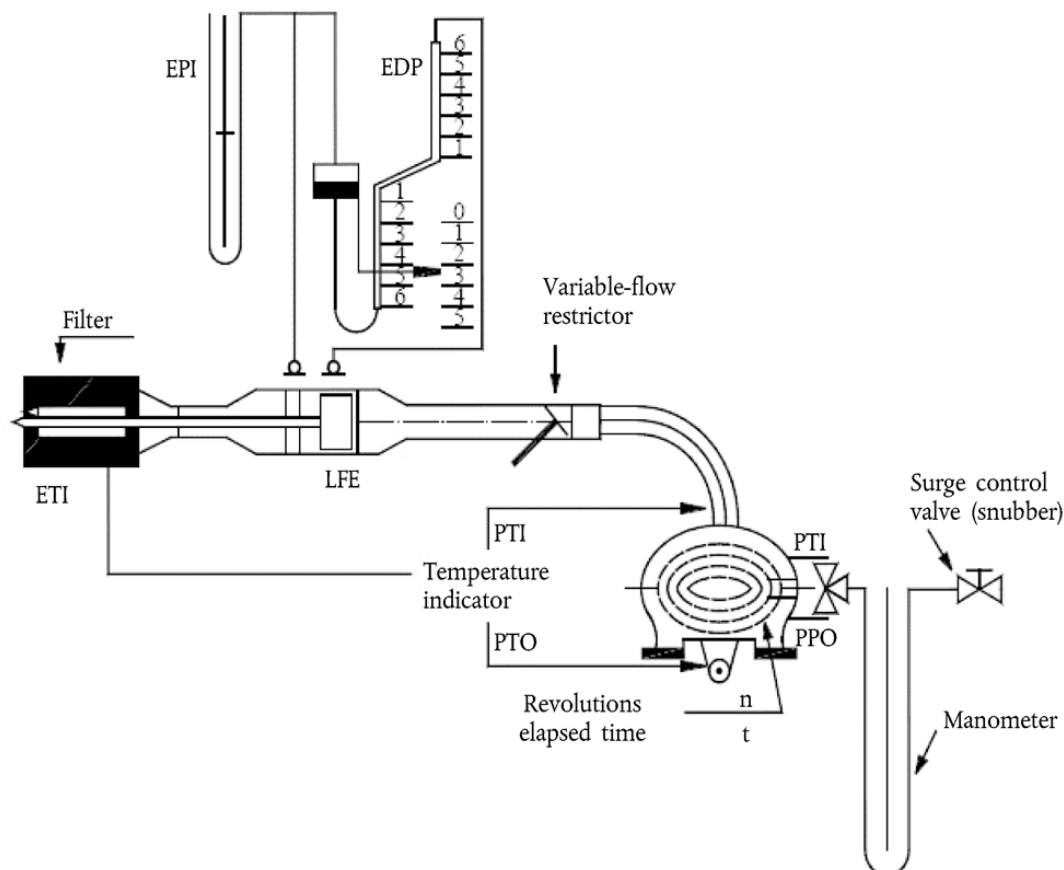

2.1 The cold and warm vehicle speed traces are identical.

3. Description of the WMTC stage 3 for L1e-A, L1e-B, L2e, L5e-B, L6e-A and L6e-B (sub-)category vehicles

Figure Ap6-11

Status: Point in time view as at 16/12/2013.

Changes to legislation: There are currently no known outstanding effects for the Commission Delegated Regulation (EU) No 134/2014. (See end of Document for details)

WMTC stage 3 for L1e-A, L1e-B, L2e, L5e-B, L6e-A and L6e-B (sub-)category vehicles. The truncated vehicle speed trace limited to 25 km/h is applicable for L1e-A and L1e-B vehicles with a limited maximum vehicle design speed of 25 km/h

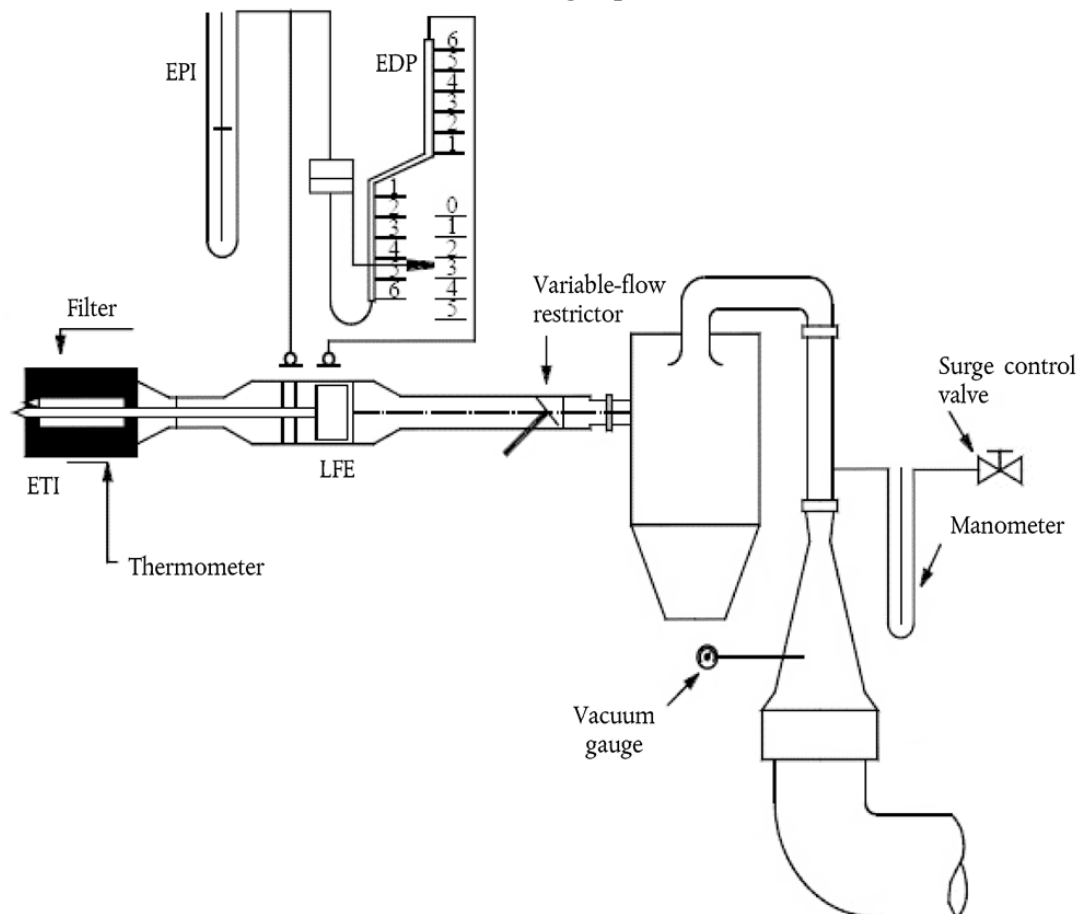

3.1. The vehicle speed trace WMTC stage 3 shown in Figure Ap 6-10 is applicable for L1e-A, L1e-B, L2e, L5e-B, L6e-A and L6e-B (sub-)category vehicles and is equivalent to the vehicle speed trace WMTC stages 1 and 2, part 1 for class 1 vehicles, driven once cold followed by the same vehicle speed driven with a warmed-up propulsion. The WMTC stage 3 for L1e-A, L1e-B, L2e, L5e-B, L6e-A and L6e-B (sub-)category vehicles lasts 1 200 seconds and consists of two equivalent parts to be carried out without interruption.

3.2. The characteristic driving conditions (idling, acceleration, steady speed, deceleration, etc.) of WMTC stage 3 for L1e-A, L1e-B, L2e, L5e-B, L6e-A and L6e-B vehicles are set out in the following points and tables.

3.2.1. TABLE AP6-27

WMTC stage 3, part 1, class 1, applicable for L1e-A and L1e-B ($v_{max} \leq 25$ km/h) sub-category vehicles, cold or warm, 0 to 180 s

time in s	roller speed in km/h	phase indicators			
		stop	acc	cruise	dec
0	0	X			

Status: Point in time view as at 16/12/2013.

Changes to legislation: There are currently no known outstanding effects for the Commission Delegated Regulation (EU) No 134/2014. (See end of Document for details)

1	0	X			
2	0	X			
3	0	X			
4	0	X			
5	0	X			
6	0	X			
7	0	X			
8	0	X			
9	0	X			
10	0	X			
11	0	X			
12	0	X			
13	0	X			
14	0	X			
15	0	X			
16	0	X			
17	0	X			
18	0	X			
19	0	X			
20	0	X			
21	0	X			
22	1		X		
23	2,6		X		
24	4,8		X		
25	7,2		X		
26	9,6		X		
27	12		X		
28	14,3		X		
29	16,6		X		
30	18,9		X		
31	21,2		X		
32	23,5		X		
33	25				
34	25				

LIST OF ANNEXES

Document Generated: 2023-10-14

Status: Point in time view as at 16/12/2013.

Changes to legislation: There are currently no known outstanding effects for the Commission Delegated Regulation (EU) No 134/2014. (See end of Document for details)

35	25				
36	25				
37	25				
38	25				
39	25			X	
40	25			X	
41	25			X	
42	25			X	
43	25			X	
44	25			X	
45	25			X	
46	25			X	
47	25			X	
48	25			X	
49	25			X	
50	25			X	
51	25			X	
52	25			X	
53	25			X	
54	25			X	
55	25			X	
56	25			X	
57	25			X	
58	25			X	
59	25			X	
60	25				X
61	25				
62	25				
63	23				X
64	18,6				X
65	14,1				X
66	9,3				X
67	4,8				X
68	1,9				X

Status: Point in time view as at 16/12/2013.

Changes to legislation: There are currently no known outstanding effects for the Commission Delegated Regulation (EU) No 134/2014. (See end of Document for details)

69	0	X			
70	0	X			
71	0	X			
72	0	X			
73	0	X			
74	1,7		X		
75	5,8		X		
76	11,8		X		
77	17,3		X		
78	22		X		
79	25				
80	25				
81	25				
82	25				
83	25				
84	25				
85	25				
86	25				
87	25				
88	25				
89	25				
90	25				
91	25			X	
92	25			X	
93	25			X	
94	25			X	
95	25			X	
96	25			X	
97	25			X	
98	25			X	
99	25			X	
100	25			X	
101	25			X	
102	25			X	

LIST OF ANNEXES

Document Generated: 2023-10-14

Status: Point in time view as at 16/12/2013.

Changes to legislation: There are currently no known outstanding effects for the Commission Delegated Regulation (EU) No 134/2014. (See end of Document for details)

103	25			X	
104	25			X	
105	25			X	
106	25			X	
107	25			X	
108	25			X	
109	25			X	
110	25				
111	25				
112	25				
113	25				
114	25				
115	25				
116	24,7			X	
117	25			X	
118	25			X	
119	25			X	
120	25			X	
121	25			X	
122	25			X	
123	25			X	
124	25			X	
125	25				
126	25				
127	25				
128	25				
129	25				
130	25				
131	25				
132	22,1				X
133	18,6				X
134	16,8		X		
135	17,7		X		

Status: Point in time view as at 16/12/2013.

Changes to legislation: There are currently no known outstanding effects for the Commission Delegated Regulation (EU) No 134/2014. (See end of Document for details)

136	21,1		X		
137	25				
138	25				
139	25				
140	25				
141	25				
142	25				
143	25				
144	25				
145	25				
146	20,3				X
147	15				X
148	9,7				X
149	5				X
150	1,6				X
151	0	X			
152	0	X			
153	0	X			
154	0	X			
155	0	X			
156	0	X			
157	0	X			
158	0	X			
159	0	X			
160	0	X			
161	0	X			
162	0	X			
163	0	X			
164	0	X			
165	0	X			
166	0	X			
167	0	X			
168	0	X			
169	0	X			

Status: Point in time view as at 16/12/2013.

Changes to legislation: There are currently no known outstanding effects for the Commission Delegated Regulation (EU) No 134/2014. (See end of Document for details)

170	0	X			
171	0	X			
172	0	X			
173	0	X			
174	0	X			
175	0	X			
176	0	X			
177	0	X			
178	0	X			
179	0	X			
180	0	X			

3.2.2.

TABLE AP6-28

WMTC stage 3, part 1, class 1, applicable for L1e-A and L1e-B ($v_{\max} \leq 25$ km/h) sub-category vehicles, cold or warm, 181 to 360 s

time in s	roller speed in km/h	phase indicators			
		stop	acc	cruise	dec
181	0	X			
182	0	X			
183	0	X			
184	0	X			
185	0,4		X		
186	1,8		X		
187	5,4		X		
188	11,1		X		
189	16,7		X		
190	21,3		X		
191	24,8		X		
192	25				
193	25				
194	25				
195	25				
196	25				
197	25				

Status: Point in time view as at 16/12/2013.

Changes to legislation: There are currently no known outstanding effects for the Commission Delegated Regulation (EU) No 134/2014. (See end of Document for details)

198	25				
199	25				
200	25				
201	25				
202	25				
203	25			X	
204	25			X	
205	25			X	
206	25			X	
207	25			X	
208	25			X	
209	25			X	
210	25			X	
211	25			X	
212	25			X	
213	25			X	
214	25			X	
215	25			X	
216	25			X	
217	25			X	
218	25			X	
219	25			X	
220	25			X	
221	25			X	
222	25			X	
223	25			X	
224	25			X	
225	25			X	
226	25			X	
227	25			X	
228	25			X	
229	25			X	
230	25			X	
231	25			X	

LIST OF ANNEXES

Document Generated: 2023-10-14

Status: Point in time view as at 16/12/2013.

Changes to legislation: There are currently no known outstanding effects for the Commission Delegated Regulation (EU) No 134/2014. (See end of Document for details)

232	25			X	
233	25			X	
234	25			X	
235	25			X	
236	25			X	
237	25			X	
238	25			X	
239	25			X	
240	25			X	
241	25			X	
242	25				
243	25				
244	25				
245	25				
246	25				
247	25				
248	21,8				X
249	17,2				X
250	13,7				X
251	10,3				X
252	7				X
253	3,5				X
254	0	X			
255	0	X			
256	0	X			
257	0	X			
258	0	X			
259	0	X			
260	0	X			
261	0	X			
262	0	X			
263	0	X			
264	0	X			
265	0	X			

Status: Point in time view as at 16/12/2013.

Changes to legislation: There are currently no known outstanding effects for the Commission Delegated Regulation (EU) No 134/2014. (See end of Document for details)

266	0	X			
267	0,5		X		
268	2,9		X		
269	8,2		X		
270	13,2		X		
271	17,8		X		
272	21,4		X		
273	24,1		X		
274	25				
275	25				
276	25				
277	25			X	
278	25			X	
279	25			X	
280	25			X	
281	25			X	
282	25			X	
283	25			X	
284	25			X	
285	25			X	
286	25			X	
287	25			X	
288	25			X	
289	25			X	
290	25			X	
291	25			X	
292	25			X	
293	25			X	
294	25			X	
295	25			X	
296	25			X	
297	25			X	
298	25			X	
299	25			X	

LIST OF ANNEXES

Document Generated: 2023-10-14

Status: Point in time view as at 16/12/2013.

Changes to legislation: There are currently no known outstanding effects for the Commission Delegated Regulation (EU) No 134/2014. (See end of Document for details)

300	25			X	
301	25			X	
302	25			X	
303	25			X	
304	25			X	
305	25			X	
306	25			X	
307	25			X	
308	25			X	
309	25			X	
310	25			X	
311	25			X	
312	25			X	
313	25			X	
314	25				
315	25				
316	22,7				X
317	19				X
318	16				X
319	14,6		X		
320	15,2		X		
321	16,9		X		
322	19,3		X		
323	22		X		
324	24,6		X		
325	25				
326	25				
327	25			X	
328	25			X	
329	25			X	
330	25			X	
331	25			X	
332	25			X	
333	25			X	

Status: Point in time view as at 16/12/2013.

Changes to legislation: There are currently no known outstanding effects for the Commission Delegated Regulation (EU) No 134/2014. (See end of Document for details)

334	25			X	
335	25			X	
336	25			X	
337	25			X	
338	25			X	
339	25			X	
340	25			X	
341	25			X	
342	25			X	
343	25			X	
344	25			X	
345	25			X	
346	25			X	
347	25			X	
348	25			X	
349	25			X	
350	25			X	
351	25			X	
352	25			X	
353	25			X	
354	25			X	
355	25			X	
356	25			X	
357	25			X	
358	25			X	
359	25			X	
360	25			X	

3.2.3.

TABLE AP6-29

WMTC stage 3, part 1, class 1, applicable for L1e-A and L1e-B ($v_{\max} \leq 25$ km/h) sub-category vehicles, cold or warm, 361 to 540 s

time in s	roller speed in km/h	phase indicators			
		stop	acc	cruise	dec
361	25			X	
362	25			X	

LIST OF ANNEXES

Document Generated: 2023-10-14

Status: Point in time view as at 16/12/2013.**Changes to legislation:** There are currently no known outstanding effects for the Commission Delegated Regulation (EU) No 134/2014. (See end of Document for details)

363	25			X	
364	25			X	
365	25			X	
366	25			X	
367	25			X	
368	25			X	
369	25			X	
370	25			X	
371	25			X	
372	25			X	
373	25			X	
374	25			X	
375	25			X	
376	25			X	
377	25			X	
378	25			X	
379	25			X	
380	25			X	
381	25			X	
382	25			X	
383	25			X	
384	25			X	
385	25			X	
386	25			X	
387	25			X	
388	25			X	
389	25			X	
390	25			X	
391	25			X	
392	25				
393	25				
394	25				
395	24,9				X
396	21,4				X

Status: Point in time view as at 16/12/2013.

Changes to legislation: There are currently no known outstanding effects for the Commission Delegated Regulation (EU) No 134/2014. (See end of Document for details)

397	15,9				X
398	9,9				X
399	4,9				X
400	2,1				X
401	0,9				X
402	0	X			
403	0	X			
404	0	X			
405	0	X			
406	0	X			
407	0	X			
408	1,2		X		
409	3,2		X		
410	5,9		X		
411	8,8		X		
412	12		X		
413	15,4		X		
414	18,9		X		
415	22,1		X		
416	24,7		X		
417	25				
418	25				
419	25				
420	25				
421	25		X		
422	25		X		
423	25		X		
424	25		X		
425	25		X		
426	25		X		
427	25		X		
428	25		X		
429	25			X	
430	25			X	

LIST OF ANNEXES

Document Generated: 2023-10-14

Status: Point in time view as at 16/12/2013.**Changes to legislation:** There are currently no known outstanding effects for the Commission Delegated Regulation (EU) No 134/2014. (See end of Document for details)

431	25			X	
432	25			X	
433	25			X	
434	25			X	
435	25			X	
436	25				
437	25				
438	25				
439	25				
440	25				
441	25				
442	25				
443	25				
444	25				
445	25				
446	25				
447	23,4				X
448	21,8				X
449	20,3				X
450	19,3				X
451	18,7				X
452	18,3				X
453	17,8				X
454	17,4				X
455	16,8				X
456	16,3			X	
457	16,5			X	
458	17,6			X	
459	19,2			X	
460	20,8			X	
461	22,2			X	
462	23			X	
463	23				X
464	22				X

Status: Point in time view as at 16/12/2013.

Changes to legislation: There are currently no known outstanding effects for the Commission Delegated Regulation (EU) No 134/2014. (See end of Document for details)

465	20,1				X
466	17,7				X
467	15				X
468	12,1				X
469	9,1				X
470	6,2				X
471	3,6				X
472	1,8				X
473	0,8				X
474	0	X			
475	0	X			
476	0	X			
477	0	X			
478	0	X			
479	0	X			
480	0	X			
481	0	X			
482	0	X			
483	0	X			
484	0	X			
485	0	X			
486	1,4		X		
487	4,5		X		
488	8,8		X		
489	13,4		X		
490	17,3		X		
491	19,2		X		
492	19,7		X		
493	19,8		X		
494	20,7		X		
495	23,7		X		
496	25				
497	25				
498	25				

LIST OF ANNEXES

Document Generated: 2023-10-14

Status: Point in time view as at 16/12/2013.

Changes to legislation: There are currently no known outstanding effects for the Commission Delegated Regulation (EU) No 134/2014. (See end of Document for details)

499	25				
500	25				
501	25				
502	25				
503	25				
504	25				
505	25				
506	25				
507	25				
508	25				
509	25				
510	23,1				X
511	16,7				X
512	10,7				X
513	4,7				X
514	1,2				X
515	0	X			
516	0	X			
517	0	X			
518	0	X			
519	3		X		
520	8,2		X		
521	14,3		X		
522	19,3		X		
523	23,5		X		
524	25				
525	25				
526	25				
527	25				
528	25				
529	25				
530	25				
531	23,2				X
532	18,5				X

Status: Point in time view as at 16/12/2013.

Changes to legislation: There are currently no known outstanding effects for the Commission Delegated Regulation (EU) No 134/2014. (See end of Document for details)

533	13,8				X
534	9,1				X
535	4,5				X
536	2,3				X
537	0	X			
538	0	X			
539	0	X			
540	0				

3.2.4.

TABLE AP6-30

WMTC stage 3, part 1, class 1, applicable for L1e-A and L1e-B ($v_{\max} \leq 25$ km/h) sub-category vehicles, cold or warm, 541 to 600 s

time in s	roller speed in km/h	phase indicators			
		stop	acc	cruise	dec
541	0	X			
542	2,8		X		
543	8,1		X		
544	14,3		X		
545	19,2		X		
546	23,5		X		
547	25				
548	25				
549	25				
550	25				
551	25				
552	25				
553	25			X	
554	25			X	
555	25			X	
556	25			X	
557	25			X	
558	25			X	
559	25			X	
560	25			X	
561	25			X	

LIST OF ANNEXES

Document Generated: 2023-10-14

Status: Point in time view as at 16/12/2013.

Changes to legislation: There are currently no known outstanding effects for the Commission Delegated Regulation (EU) No 134/2014. (See end of Document for details)

562	25			X	
563	25			X	
564	25			X	
565	25			X	
566	25			X	
567	25			X	
568	25			X	
569	25			X	
570	25			X	
571	25			X	
572	25			X	
573	25				
574	25				
575	25				
576	25				
577	25				
578	25				
579	25				
580	25				
581	25				
582	21,8				X
583	17,7				X
584	13,5				X
585	9,4				X
586	5,6				X
587	2,1				X
588	0	X			
589	0	X			
590	0	X			
591	0	X			
592	0	X			
593	0	X			
594	0	X			
595	0	X			

Status: Point in time view as at 16/12/2013.

Changes to legislation: There are currently no known outstanding effects for the Commission Delegated Regulation (EU) No 134/2014. (See end of Document for details)

596	0	X			
597	0	X			
598	0	X			
599	0	X			
600	0	X			

3.2.5.

TABLE AP6-31

WMTC stage 3, part 1, class 1, applicable for L1e-A and L1e-B ($v_{\max} \leq 45$ km/h) sub-category vehicles, cold or warm, 0 to 180 s

time in s	roller speed in km/h	phase indicators			
		stop	acc	cruise	dec
0	0	X			
1	0	X			
2	0	X			
3	0	X			
4	0	X			
5	0	X			
6	0	X			
7	0	X			
8	0	X			
9	0	X			
10	0	X			
11	0	X			
12	0	X			
13	0	X			
14	0	X			
15	0	X			
16	0	X			
17	0	X			
18	0	X			
19	0	X			
20	0	X			
21	0	X			
22	1		X		
23	2,6		X		

LIST OF ANNEXES

Document Generated: 2023-10-14

Status: Point in time view as at 16/12/2013.**Changes to legislation:** There are currently no known outstanding effects for the Commission Delegated Regulation (EU) No 134/2014. (See end of Document for details)

24	4,8		X		
25	7,2		X		
26	9,6		X		
27	12		X		
28	14,3		X		
29	16,6		X		
30	18,9		X		
31	21,2		X		
32	23,5		X		
33	25,6		X		
34	27,1		X		
35	28		X		
36	28,7		X		
37	29,2		X		
38	29,8		X		
39	30,3			X	
40	29,6			X	
41	28,7			X	
42	27,9			X	
43	27,4			X	
44	27,3			X	
45	27,3			X	
46	27,4			X	
47	27,5			X	
48	27,6			X	
49	27,6			X	
50	27,6			X	
51	27,8			X	
52	28,1			X	
53	28,5			X	
54	28,9			X	
55	29,2			X	
56	29,4			X	
57	29,7			X	

Status: Point in time view as at 16/12/2013.

Changes to legislation: There are currently no known outstanding effects for the Commission Delegated Regulation (EU) No 134/2014. (See end of Document for details)

58	30			X	
59	30,5			X	
60	30,6				X
61	29,6				X
62	26,9				X
63	23				X
64	18,6				X
65	14,1				X
66	9,3				X
67	4,8				X
68	1,9				X
69	0	X			
70	0	X			
71	0	X			
72	0	X			
73	0	X			
74	1,7		X		
75	5,8		X		
76	11,8		X		
77	17,3		X		
78	22		X		
79	26,2		X		
80	29,4		X		
81	31,1		X		
82	32,9		X		
83	34,7		X		
84	34,8		X		
85	34,8		X		
86	34,9		X		
87	35,4		X		
88	36,2		X		
89	37,1		X		
90	38		X		
91	38,7			X	

LIST OF ANNEXES

Document Generated: 2023-10-14

Status: Point in time view as at 16/12/2013.**Changes to legislation:** There are currently no known outstanding effects for the Commission Delegated Regulation (EU) No 134/2014. (See end of Document for details)

92	38,9			X	
93	38,9			X	
94	38,8			X	
95	38,5			X	
96	38,1			X	
97	37,5			X	
98	37			X	
99	36,7			X	
100	36,5			X	
101	36,5			X	
102	36,6			X	
103	36,8			X	
104	37			X	
105	37,1			X	
106	37,3			X	
107	37,4			X	
108	37,5			X	
109	37,4			X	
110	36,9				X
111	36				X
112	34,8				X
113	31,9				X
114	29				X
115	26,9				X
116	24,7			X	
117	25,4			X	
118	26,4			X	
119	27,7			X	
120	29,4			X	
121	31,2			X	
122	33			X	
123	34,4			X	
124	35,2			X	

Status: Point in time view as at 16/12/2013.

Changes to legislation: There are currently no known outstanding effects for the Commission Delegated Regulation (EU) No 134/2014. (See end of Document for details)

125	35,4				X
126	35,2				X
127	34,7				X
128	33,9				X
129	32,4				X
130	29,8				X
131	26,1				X
132	22,1				X
133	18,6				X
134	16,8		X		
135	17,7		X		
136	21,1		X		
137	25,4		X		
138	29,2		X		
139	31,6		X		
140	32,1				X
141	31,6				X
142	30,7				X
143	29,7				X
144	28,1				X
145	25				X
146	20,3				X
147	15				X
148	9,7				X
149	5				X
150	1,6				X
151	0	X			
152	0	X			
153	0	X			
154	0	X			
155	0	X			
156	0	X			
157	0	X			
158	0	X			

Status: Point in time view as at 16/12/2013.

Changes to legislation: There are currently no known outstanding effects for the Commission Delegated Regulation (EU) No 134/2014. (See end of Document for details)

159	0	X			
160	0	X			
161	0	X			
162	0	X			
163	0	X			
164	0	X			
165	0	X			
166	0	X			
167	0	X			
168	0	X			
169	0	X			
170	0	X			
171	0	X			
172	0	X			
173	0	X			
174	0	X			
175	0	X			
176	0	X			
177	0	X			
178	0	X			
179	0	X			
180	0	X			

3.2.6.

TABLE AP6-32

WMTC stage 3, part 1, class 1, applicable for L1e-A and L1e-B ($v_{\max} \leq 45$ km/h) sub-category vehicles, cold or warm, 181 to 360 s

time in s	roller speed in km/h	phase indicators			
		stop	acc	cruise	dec
181	0	X			
182	0	X			
183	0	X			
184	0	X			
185	0,4		X		
186	1,8		X		

Status: Point in time view as at 16/12/2013.

Changes to legislation: There are currently no known outstanding effects for the Commission Delegated Regulation (EU) No 134/2014. (See end of Document for details)

187	5,4		X		
188	11,1		X		
189	16,7		X		
190	21,3		X		
191	24,8		X		
192	28,4		X		
193	31,8		X		
194	34,6		X		
195	36,3		X		
196	37,8		X		
197	39,6		X		
198	41,3		X		
199	43,3		X		
200	45				
201	45				
202	45				
203	45			X	
204	45			X	
205	45			X	
206	45			X	
207	45			X	
208	45			X	
209	45			X	
210	45			X	
211	45			X	
212	45			X	
213	45			X	
214	45			X	
215	45			X	
216	45			X	
217	45			X	
218	45			X	
219	45			X	
220	45			X	

LIST OF ANNEXES

Document Generated: 2023-10-14

Status: Point in time view as at 16/12/2013.

Changes to legislation: There are currently no known outstanding effects for the Commission Delegated Regulation (EU) No 134/2014. (See end of Document for details)

221	45			X	
222	45			X	
223	45			X	
224	45			X	
225	45			X	
226	45			X	
227	45			X	
228	45			X	
229	45			X	
230	45			X	
231	45			X	
232	45			X	
233	45			X	
234	45			X	
235	45			X	
236	44,4			X	
237	43,5			X	
238	43,2			X	
239	43,3			X	
240	43,7			X	
241	43,9			X	
242	43,8				X
243	43				X
244	40,9				X
245	36,9				X
246	32,1				X
247	26,6				X
248	21,8				X
249	17,2				X
250	13,7				X
251	10,3				X
252	7				X
253	3,5				X
254	0	X			

Status: Point in time view as at 16/12/2013.

Changes to legislation: There are currently no known outstanding effects for the Commission Delegated Regulation (EU) No 134/2014. (See end of Document for details)

255	0	X			
256	0	X			
257	0	X			
258	0	X			
259	0	X			
260	0	X			
261	0	X			
262	0	X			
263	0	X			
264	0	X			
265	0	X			
266	0	X			
267	0,5		X		
268	2,9		X		
269	8,2		X		
270	13,2		X		
271	17,8		X		
272	21,4		X		
273	24,1		X		
274	26,4		X		
275	28,4		X		
276	29,9		X		
277	30,5			X	
278	30,5			X	
279	30,3			X	
280	30,2			X	
281	30,1			X	
282	30,1			X	
283	30,1			X	
284	30,2			X	
285	30,2			X	
286	30,2			X	
287	30,2			X	
288	30,5			X	

LIST OF ANNEXES

Document Generated: 2023-10-14

Status: Point in time view as at 16/12/2013.**Changes to legislation:** There are currently no known outstanding effects for the Commission Delegated Regulation (EU) No 134/2014. (See end of Document for details)

289	31			X	
290	31,9			X	
291	32,8			X	
292	33,7			X	
293	34,5			X	
294	35,1			X	
295	35,5			X	
296	35,6			X	
297	35,4			X	
298	35			X	
299	34			X	
300	32,4			X	
301	30,6			X	
302	29			X	
303	27,8			X	
304	27,2			X	
305	26,9			X	
306	26,5			X	
307	26,1			X	
308	25,7			X	
309	25,5			X	
310	25,7			X	
311	26,4			X	
312	27,3			X	
313	28,1			X	
314	27,9				X
315	26				X
316	22,7				X
317	19				X
318	16				X
319	14,6		X		
320	15,2		X		
321	16,9		X		
322	19,3		X		

Status: Point in time view as at 16/12/2013.

Changes to legislation: There are currently no known outstanding effects for the Commission Delegated Regulation (EU) No 134/2014. (See end of Document for details)

323	22		X		
324	24,6		X		
325	26,8		X		
326	27,9		X		
327	28			X	
328	27,7			X	
329	27,1			X	
330	26,8			X	
331	26,6			X	
332	26,8			X	
333	27			X	
334	27,2			X	
335	27,4			X	
336	27,5			X	
337	27,7			X	
338	27,9			X	
339	28,1			X	
340	28,3			X	
341	28,6			X	
342	29,1			X	
343	29,6			X	
344	30,1			X	
345	30,6			X	
346	30,8			X	
347	30,8			X	
348	30,8			X	
349	30,8			X	
350	30,8			X	
351	30,8			X	
352	30,8			X	
353	30,8			X	
354	30,9			X	
355	30,9			X	
356	30,9			X	

Status: Point in time view as at 16/12/2013.

Changes to legislation: There are currently no known outstanding effects for the Commission Delegated Regulation (EU) No 134/2014. (See end of Document for details)

357	30,8			X	
358	30,4			X	
359	29,6			X	
360	28,4			X	

3.2.7.

TABLE AP6-33

WMTC stage 3, part 1, class 1, applicable for L1e-A and L1e-B ($v_{max} \leq 45$ km/h) sub-category vehicles, cold or warm, 361 to 540 s

time in s	roller speed in km/h	phase indicators			
		stop	acc	cruise	dec
361	27,1			X	
362	26			X	
363	25,4			X	
364	25,5			X	
365	26,3			X	
366	27,3			X	
367	28,3			X	
368	29,2			X	
369	29,5			X	
370	29,4			X	
371	28,9			X	
372	28,1			X	
373	27,1			X	
374	26,3			X	
375	25,7			X	
376	25,5			X	
377	25,6			X	
378	25,9			X	
379	26,3			X	
380	26,9			X	
381	27,6			X	
382	28,4			X	
383	29,3			X	
384	30,1			X	
385	30,4			X	

Status: Point in time view as at 16/12/2013.

Changes to legislation: There are currently no known outstanding effects for the Commission Delegated Regulation (EU) No 134/2014. (See end of Document for details)

386	30,2			X	
387	29,5			X	
388	28,6			X	
389	27,9			X	
390	27,5			X	
391	27,2			X	
392	26,9				X
393	26,4				X
394	25,7				X
395	24,9				X
396	21,4				X
397	15,9				X
398	9,9				X
399	4,9				X
400	2,1				X
401	0,9				X
402	0	X			
403	0	X			
404	0	X			
405	0	X			
406	0	X			
407	0	X			
408	1,2		X		
409	3,2		X		
410	5,9		X		
411	8,8		X		
412	12		X		
413	15,4		X		
414	18,9		X		
415	22,1		X		
416	24,7		X		
417	26,8		X		
418	28,7		X		
419	30,6		X		

LIST OF ANNEXES

Document Generated: 2023-10-14

Status: Point in time view as at 16/12/2013.**Changes to legislation:** There are currently no known outstanding effects for the Commission Delegated Regulation (EU) No 134/2014. (See end of Document for details)

420	32,4		X		
421	34		X		
422	35,4		X		
423	36,5		X		
424	37,5		X		
425	38,6		X		
426	39,6		X		
427	40,7		X		
428	41,4		X		
429	41,7			X	
430	41,4			X	
431	40,9			X	
432	40,5			X	
433	40,2			X	
434	40,1			X	
435	40,1			X	
436	39,8				X
437	38,9				X
438	37,4				X
439	35,8				X
440	34,1				X
441	32,5				X
442	30,9				X
443	29,4				X
444	27,9				X
445	26,5				X
446	25				X
447	23,4				X
448	21,8				X
449	20,3				X
450	19,3				X
451	18,7				X
452	18,3				X
453	17,8				X

Status: Point in time view as at 16/12/2013.

Changes to legislation: There are currently no known outstanding effects for the Commission Delegated Regulation (EU) No 134/2014. (See end of Document for details)

454	17,4				X
455	16,8				X
456	16,3			X	
457	16,5			X	
458	17,6			X	
459	19,2			X	
460	20,8			X	
461	22,2			X	
462	23			X	
463	23				X
464	22				X
465	20,1				X
466	17,7				X
467	15				X
468	12,1				X
469	9,1				X
470	6,2				X
471	3,6				X
472	1,8				X
473	0,8				X
474	0	X			
475	0	X			
476	0	X			
477	0	X			
478	0	X			
479	0	X			
480	0	X			
481	0	X			
482	0	X			
483	0	X			
484	0	X			
485	0	X			
486	1,4		X		
487	4,5		X		

LIST OF ANNEXES

Document Generated: 2023-10-14

Status: Point in time view as at 16/12/2013.**Changes to legislation:** There are currently no known outstanding effects for the Commission Delegated Regulation (EU) No 134/2014. (See end of Document for details)

488	8,8		X		
489	13,4		X		
490	17,3		X		
491	19,2		X		
492	19,7		X		
493	19,8		X		
494	20,7		X		
495	23,7		X		
496	27,9		X		
497	31,9		X		
498	35,4		X		
499	36,2				X
500	34,2				X
501	30,2				X
502	27,1				X
503	26,6		X		
504	28,6		X		
505	32,6		X		
506	35,5		X		
507	36,6				X
508	34,6				X
509	30				X
510	23,1				X
511	16,7				X
512	10,7				X
513	4,7				X
514	1,2				X
515	0	X			
516	0	X			
517	0	X			
518	0	X			
519	3		X		
520	8,2		X		
521	14,3		X		

Status: Point in time view as at 16/12/2013.

Changes to legislation: There are currently no known outstanding effects for the Commission Delegated Regulation (EU) No 134/2014. (See end of Document for details)

522	19,3		X		
523	23,5		X		
524	27,3		X		
525	30,8		X		
526	33,7		X		
527	35,2		X		
528	35,2				X
529	32,5				X
530	27,9				X
531	23,2				X
532	18,5				X
533	13,8				X
534	9,1				X
535	4,5				X
536	2,3				X
537	0	X			
538	0	X			
539	0	X			
540	0	X			

3.2.8.

TABLE AP6-34

WMTC stage 3, part 1, class 1, applicable for L1e-A and L1e-B ($v_{\max} \leq 45$ km/h) sub-category vehicles, cold or warm, 541 to 600 s

time in s	roller speed in km/h	phase indicators			
		stop	acc	cruise	dec
541	0	X			
542	2,8		X		
543	8,1		X		
544	14,3		X		
545	19,2		X		
546	23,5		X		
547	27,2		X		
548	30,5		X		
549	33,1		X		
550	35,7		X		

LIST OF ANNEXES

Document Generated: 2023-10-14

Status: Point in time view as at 16/12/2013.**Changes to legislation:** There are currently no known outstanding effects for the Commission Delegated Regulation (EU) No 134/2014. (See end of Document for details)

551	38,3		X		
552	41		X		
553	43,6			X	
554	43,7			X	
555	43,8			X	
556	43,9			X	
557	44			X	
558	44,1			X	
559	44,2			X	
560	44,3			X	
561	44,4			X	
562	44,5			X	
563	44,6			X	
564	44,9			X	
565	45			X	
566	45			X	
567	45			X	
568	45			X	
569	45			X	
570	45			X	
571	45			X	
572	45			X	
573	45				
574	45				
575	45				
576	42,3				X
577	39,5				X
578	36,6				X
579	33,7				X
580	30,1				X
581	26				X
582	21,8				X
583	17,7				X
584	13,5				X

Status: Point in time view as at 16/12/2013.

Changes to legislation: There are currently no known outstanding effects for the Commission Delegated Regulation (EU) No 134/2014. (See end of Document for details)

585	9,4				X
586	5,6				X
587	2,1				X
588	0	X			
589	0	X			
590	0	X			
591	0	X			
592	0	X			
593	0	X			
594	0	X			
595	0	X			
596	0	X			
597	0	X			
598	0	X			
599	0	X			
600	0	X			

Appendix 7

Road tests of L-category vehicles equipped with one wheel on the driven axle or with twinned wheels for the determination of test bench settings

1. Requirements for the rider

- 1.1. The rider shall wear a well-fitting (one-piece) suit or similar clothing and a protective helmet, eye protection, boots and gloves.
- 1.2. The rider, dressed and equipped as described in point 1.1., shall have a mass of 75 kg \pm 5 kg and be 1,75 m \pm 0,05 m tall.
- 1.3. The rider shall be seated on the seat provided, with his feet on the footrests and his arms extended normally. This position shall allow the rider to have proper control of the vehicle at all times during the tests.

2. Requirement for the road and ambient conditions

- 2.1. The test road shall be flat, level, straight and smoothly paved. The road surface shall be dry and free of obstacles or wind barriers that might impede the measurement of the running resistance. The slope of the surface shall not exceed 0,5 percent between any two points at least 2 m apart.
- 2.2. During data collecting periods, the wind shall be steady. The wind speed and the direction of the wind shall be measured continuously or with adequate frequency at a location where the wind force during coast-down is representative.
- 2.3. The ambient conditions shall be within the following limits:
 - maximum wind speed: 3 m/s
 - maximum wind speed for gusts: 5 m/s
 - average wind speed, parallel: 3 m/s
 - average wind speed, perpendicular: 2 m/s
 - maximum relative humidity: 95 percent
 - air temperature: 278,2 K to 308,2 K
- 2.4. Standard ambient conditions shall be as follows:
 - pressure, P_0 : 100 kPa
 - temperature, T_0 : 293,2 K
 - relative air density, d_0 : 0,9197
 - air volumetric mass, ρ_0 : 1,189 kg/m³
- 2.5. The relative air density when the vehicle is tested, calculated in accordance with the formula Ap 7-1, shall not differ by more than 7,5 percent from the air density under the standard conditions.
- 2.6. The relative air density, d_T , shall be calculated using the following formula:

Equation Ap 7-1:

$$d_T = d_0 \times \frac{P_T}{P_0} \times \frac{T_0}{T_T}$$

where:

Status: Point in time view as at 16/12/2013.

Changes to legislation: There are currently no known outstanding effects for the Commission Delegated Regulation (EU) No 134/2014. (See end of Document for details)

d_0 is the reference relative air density at reference conditions (1,189 kg/m³)

p_T is the mean ambient pressure during the test, in kPa;

p_0 is the reference ambient pressure (101,3 kPa);

T_T is the mean ambient temperature during test, in K;

T_0 is the reference ambient temperature (293,2 K).

3. Condition of the test vehicle

3.1. The test vehicle shall comply with the conditions described in point 1 of Appendix 8.

3.2. When installing the measuring instruments on the test vehicle, care shall be taken to minimise their effects on the distribution of the load across the wheels. When installing the speed sensor outside the vehicle, care shall be taken to minimise the additional aerodynamic loss.

3.3. Checks

The following checks shall be made in accordance with the manufacturer's specifications for the use considered: wheels, wheel rims, tyres (make, type and pressure), front axle geometry, brake adjustment (elimination of parasitic drag), lubrication of front and rear axles, adjustment of the suspension and vehicle ground clearance, etc. Check that during freewheeling, there is no electrical braking.

4. Specified coast-down speeds

4.1. The coast-down times must be measured between v_1 and v_2 as specified in Table Ap 7-1, depending on the vehicle class as defined in point 4.3. of Annex II.

4.2. *TABLE AP7-1*

Coast-down time measurement beginning speed and ending speed

Maximum design speed (km/h)	Specified target vehicle speed v_j in (km/h)	v_1 in (km/h)	v_2 in (km/h)
≤ 25 km/h			
	20	25	15
	15	20	10
	10	15	5
≤ 45 km/h			
	40	45	35
	30	35	25
	20	25	15
$45 < \text{maximum design speed} \leq 130$ km/h and > 130 km/h			
	120	130*/	110
	100	110*/	90
	80	90*/	70
	60	70	50

Status: Point in time view as at 16/12/2013.

Changes to legislation: There are currently no known outstanding effects for the Commission Delegated Regulation (EU) No 134/2014. (See end of Document for details)

	40	45	35
	20	25	15

4.3. When the running resistance is verified in accordance with point 5.2.2.3.2., the test can be executed at $v_j \pm 5$ km/h, provided that the coast-down time accuracy referred to in point 4.5.7. of Annex II is ensured.

5. Measurement of coast-down time

5.1. After a warm-up period, the vehicle shall be accelerated to the coast-down starting speed, at which point the coast-down measurement procedure shall be started.

5.2. Since shifting the transmission to neutral can be dangerous and complicated by the construction of the vehicle, the coasting may be performed solely with the clutch disengaged. Vehicles that have no means of cutting the transmitted engine power off prior to coasting may be towed until they reach the coast-down starting speed. When the coast-down test is reproduced on the chassis dynamometer, the drive train and clutch shall be in the same condition as during the road test.

5.3. The vehicle steering shall be altered as little as possible and the brakes shall not be operated until the end of the coast-down measurement period.

5.4. The first coast-down time Δt_{ai} corresponding to the specified speed v_j shall be measured as the time taken for the vehicle to decelerate from $v_j + \Delta v$ to $v_j - \Delta v$.

5.5. The procedure described in points 5.1. to 5.4. shall be repeated in the opposite direction to measure the second coast-down time Δt_{bi} .

5.6. The average Δt_i of the two coast-down times Δt_{ai} and Δt_{bi} shall be calculated using the following equation:

Equation Ap 7-2:

$$\Delta t_i = \frac{\Delta t_{ai} + \Delta t_{bi}}{2}$$

5.7. At least four tests shall be performed and the average coast-down time ΔT_j calculated using the following equation:

Equation Ap 7-3:

$$\Delta t_j = \frac{1}{n} \times \sum_{i=1}^n \Delta t_i$$

5.8. Tests shall be performed until the statistical accuracy P is equal to or less than 3 percent ($P \leq 3$ percent).

The statistical accuracy P (as a percentage) is calculated using the following equation:

Equation Ap7-4:

$$P = \frac{t \times s}{\sqrt{n}} \times \frac{100}{\Delta t_j}$$

where:

t is the coefficient given in Table Ap 7-2;

s is the standard deviation given by the following formula:

Equation Ap7-5:

$$s = \sqrt{\frac{\sum_{i=1}^n (\Delta t_i - \Delta t_j)^2}{n-1}}$$

where:

Status: Point in time view as at 16/12/2013.

Changes to legislation: There are currently no known outstanding effects for the Commission Delegated Regulation (EU) No 134/2014. (See end of Document for details)

n is the number of tests.

Table Ap7-2

Coefficients for statistical accuracy

n	t	$\frac{t}{\sqrt{n}}$
4	3,2	1,6
5	2,8	1,25
6	2,6	1,06
7	2,5	0,94
8	2,4	0,85
9	2,3	0,77
10	2,3	0,73
11	2,2	0,66
12	2,2	0,64
13	2,2	0,61
14	2,2	0,59
15	2,2	0,57

- 5.9. In repeating the test, care shall be taken to start the coast-down after observing the same warm-up procedure and at the same coast-down starting speed.
- 5.10. The coast-down times for multiple specified speeds may be measured in a continuous coast-down. In this case, the coast-down shall be repeated after observing the same warm-up procedure and at the same coast-down starting speed.
- 5.11. The coast-down time shall be recorded. A specimen record form is given in the Regulation for administrative requirements.

6. Data processing

6.1. Calculation of running resistance force

- 6.1.1. The running resistance force F_j , in Newton, at the specified speed v_j shall be calculated using the following equation:

Equation Ap7-6:

$$F_j = \frac{1}{3,6} \times m_{\text{ref}} \times \frac{2 \times \Delta v}{\Delta t}$$

where:

- m_{ref} = reference mass (kg);
 Δv = vehicle speed deviation (km/h);
 Δt = calculated coast down time difference (s);

- 6.1.2. The running resistance force F_j shall be corrected in accordance with point 6.2.

Status: Point in time view as at 16/12/2013.

Changes to legislation: There are currently no known outstanding effects for the Commission Delegated Regulation (EU) No 134/2014. (See end of Document for details)

6.2. Running resistance curve fitting

The running resistance force, F , shall be calculated as follows:

- 6.2.1. The following equation shall be fitted to the data set of F_j and v_j obtained in points 4 and 6.1. respectively by linear regression to determine the coefficients f_0 and f_2 ,

Equation Ap7-7:

$$F = f_0 + f_2 \times v^2$$

- 6.2.2. The coefficients f_0 and f_2 thus determined shall be corrected to the standard ambient conditions using the following equations:

Equation Ap7-8:

$$f_0^2 = f_0 = [1 + K_0(T_T - T_0)]$$

Equation Ap7-9:

$$f_2^2 = f_2 \times \frac{T_T}{T_0} \times \frac{p_0}{p_T}$$

where:

K_0 shall be determined on the basis of the empirical data for the particular vehicle and tyre tests or shall be assumed as follows, if the information is not available:

$$K_0 = 6 \times 10^{-3} K^{-1}$$

6.3. Target running resistance force F^* for chassis dynamometer setting

The target running resistance force $F^*(v_0)$ on the chassis dynamometer at the reference vehicle speed v_0 , in Newton, is determined using the following equation:

Equation Ap7-10:

$$F^*(v_0) = f_0^2 + f_2^2 \times v_0^2$$

Status: Point in time view as at 16/12/2013.

Changes to legislation: There are currently no known outstanding effects for the Commission Delegated Regulation (EU) No 134/2014. (See end of Document for details)

Appendix 8

Road tests of L-category vehicles equipped with two or more wheels on the powered axles for the determination of test bench settings

1. Preparation of the vehicle

1.1. Running-in

The test vehicle shall be in normal running order and adjustment after having been run in for at least 300 km. The tyres shall be run in at the same time as the vehicle or shall have a tread depth within 90 and 50 percent of the initial tread depth.

1.2. Checks

The following checks shall be made in accordance with the manufacturer's specifications for the use considered: wheels, wheel rims, tyres (make, type and pressure), front axle geometry, brake adjustment (elimination of parasitic drag), lubrication of front and rear axles, adjustment of the suspension and vehicle ground clearance, etc. Check that during freewheeling, there is no electrical braking.

1.3. Preparation for the test

1.3.1. The test vehicle shall be loaded to its test mass including driver and measurement equipment, spread in a uniform way in the loading areas.

1.3.2. The windows of the vehicle shall be closed. Any covers for air conditioning systems, headlamps, etc. shall be closed.

1.3.3. The test vehicle shall be clean, properly maintained and used.

1.3.4. Immediately before the test, the vehicle shall be brought to the normal running temperature in an appropriate manner.

1.3.5. When installing the measuring instruments on the test vehicle, care shall be taken to minimise their effects on the distribution of the load across the wheels. When installing the speed sensor outside the test vehicle, care shall be taken to minimise the additional aerodynamic loss.

2. Specified vehicle speed v

The specified speed is required for determining the running resistance at the reference speed from the running resistance curve. To determine the running resistance as a function of vehicle speed in the vicinity of the reference speed v_0 , running resistances shall be measured at the specified speed v . At least four to five points indicating the specified speeds, along with the reference speeds, shall be measured. The calibration of the load indicator referred to in point 2.2. of Appendix 3 shall be performed at the applicable reference vehicle speed (v_j) referred to in Table Ap8-1.

TABLE AP8-1

Specified vehicle speeds to perform the coast-down time test as well as the designated reference vehicle speed v_j depending on the maximum design speed (v_{\max}) of the vehicle

Status: Point in time view as at 16/12/2013.

Changes to legislation: There are currently no known outstanding effects for the Commission Delegated Regulation (EU) No 134/2014. (See end of Document for details)

Category	v _{max} Vehicle speed (km/h)					
> 130	120 ^b	100	80 ^a	60	40	20
130-100	90	80 ^a	60	40	20	—
100-70	60	50 ^a	40	30	20	—
70-45	50 ^b	40 ^a	30	20	—	—
45-25		40	30 ^a	20		
≤ 25 km/h				20	15 ^a	10

a Applicable reference vehicle speed v_j

b if the vehicle speed can be attained by the vehicle.

3. Energy variation during coast-down procedure

3.1. Total road load power determination

3.1.1. Measurement equipment and accuracy

The margin of measurement error shall be less than 0,1 second for time and less than ± 0,5 km/h for speed. Bring the vehicle and the chassis dynamometer to the stabilised operating temperature, in order to approximate the road conditions.

3.1.2. Test procedure

3.1.2.1. Accelerate the vehicle to a speed of 5 km/h greater than the speed at which test measurement begins.

3.1.2.2. Put the gearbox to neutral or disconnect the power supply.

3.1.2.3. Measure the time t₁ taken by the vehicle to decelerate from:

$$v_2 = v + \Delta v (\text{km} / \text{h})$$

to

$$v_1 = v - \Delta v (\text{km} / \text{h})$$

where:

Δv < 5 km/h for nominal vehicle speed < 50 km/h;

Δv < 10 km/h for nominal vehicle speed > 50 km/h.

3.1.2.4. Carry out the same test in the opposite direction, measuring time t₂.

3.1.2.5. Take the average t_i of the two times t₁ and t₂.

3.1.2.6. Repeat these tests until the statistical accuracy (p) of the average:

Equation Ap 8-1:

$$\Delta t_j = \frac{1}{n} \times \sum_{i=1}^n \Delta t_i$$

The statistical accuracy (p) is defined by:

Equation Ap 8-2:

$$p = \frac{t \times s}{\sqrt{n}} \times \frac{100}{t}$$

Status: Point in time view as at 16/12/2013.

Changes to legislation: There are currently no known outstanding effects for the Commission Delegated Regulation (EU) No 134/2014. (See end of Document for details)

is no more than 4 percent ($p \leq 4$ percent).

where:

t is the coefficient in Table Ap 8-2;

s is the standard deviation.

Equation Ap 8-3:

$$s = \sqrt{\sum_{i=1}^n \frac{(\Delta t_i - \Delta t_f)^2}{n-1}}$$

n is the number of tests

TABLE AP8-2

Factors t and t/\sqrt{n} depending on the number of coast-down tests performed

n	4	5	6	7	8	9	10
t	3,2	2,8	2,6	2,5	2,4	2,3	2,3
t/\sqrt{n}	1,6	1,25	1,06	0,94	0,85	0,77	0,73

3.1.2.7. Calculation of the running resistance force

The running resistance force F at the specified vehicle speeds v is calculated as follows:

Equation Ap 8-4:

$$F = \frac{1}{3,6} \times m_{ref} \times \frac{2 \times \Delta v}{\Delta t}$$

where:

m_{ref} = reference mass (kg);

Δv = vehicle speed deviation (km/h);

Δt = calculated coast down time difference (s);

3.1.2.8. The running resistance determined on the track shall be corrected to the reference ambient conditions as follows:

Equation Ap 8-5:

$$F_{corrected} = k \times F_{measured}$$

Equation Ap 8-6:

$$k = \frac{R_R}{R_T} \times [1 + K_R \times (t - t_0)] + \frac{R_{AERO} \times d_0}{R_T \times d_t}$$

where:

R_R is the rolling resistance at speed v (N);

R_{AERO} is the aerodynamic drag at speed v (N);

R_T is

$$\text{the total road load} = R_R + R_{AERO}$$

(N);

K_R is the temperature correction factor of rolling resistance, taken to be equal to:

$$3,6 \times 10^{-3} / K$$

;

t is the road test ambient temperature in K;

t_0 is the reference ambient temperature (293,2 K);

Status: Point in time view as at 16/12/2013.

Changes to legislation: There are currently no known outstanding effects for the Commission Delegated Regulation (EU) No 134/2014. (See end of Document for details)

d_t is the air density at the test conditions (kg/m^3);

d_0 is the air density at the reference conditions (293,2 K, 101,3 kPa) = 1,189 kg/m^3 .

The ratios R_R/R_T and R_{AERO}/R_T shall be specified by the vehicle manufacturer on the basis of the data normally available to the company and to the satisfaction of the technical service. If these values are not available or if the technical service or approval authority do not accept these values, the following figures for the rolling/total resistance ratio given by the following formula may be used:

Equation Ap 8-7:

$$\frac{R_R}{R_T} = a \times m_{HP} + b$$

where:

m_{HP} is the test mass and for each speed the coefficients a and b are as shown in the following table:

TABLE AP8-3

Coefficients a and b to calculate rolling resistance ratio

v (km/h)	a	b
20	$7,24 \cdot 10^{-5}$	0,82
40	$1,59 \cdot 10^{-4}$	0,54
60	$1,96 \cdot 10^{-4}$	0,33
80	$1,85 \cdot 10^{-4}$	0,23
100	$1,63 \cdot 10^{-4}$	0,18
120	$1,57 \cdot 10^{-4}$	0,14

3.2. Setting of the chassis dynamometer

The purpose of this procedure is to simulate on the dynamometer the total road load power at a given speed.

3.2.1. Measurement equipment and accuracy

The measuring equipment shall be similar to that used on the test track and shall comply with point 4.5.7. of Annex II and point 1.3.5 of this Appendix.

3.2.2. Test procedure

3.2.2.1. Install the vehicle on the chassis dynamometer.

3.2.2.2. Adjust the tyre pressure (cold) of the driving wheels as required for the chassis dynamometer.

3.2.2.3. Adjust the equivalent inertia mass of the chassis dynamometer, in accordance with Table Ap8-4.

Status: Point in time view as at 16/12/2013.

Changes to legislation: There are currently no known outstanding effects for the Commission Delegated Regulation (EU) No 134/2014. (See end of Document for details)

3.2.2.3.1.

TABLE AP8-4

Determination of equivalent inertia mass for an L-category vehicle equipped with two or more wheels on the powered axles

Reference mass (m_{ref})(kg)	Equivalent inertia mass (m_i)(kg)
$m_{ref} \leq 105$	100
$105 < m_{ref} \leq 115$	110
$115 < m_{ref} \leq 125$	120
$125 < m_{ref} \leq 135$	130
$135 < m_{ref} \leq 150$	140
$150 < m_{ref} \leq 165$	150
$165 < m_{ref} \leq 185$	170
$185 < m_{ref} \leq 205$	190
$205 < m_{ref} \leq 225$	210
$225 < m_{ref} \leq 245$	230
$245 < m_{ref} \leq 270$	260
$270 < m_{ref} \leq 300$	280
$300 < m_{ref} \leq 330$	310
$330 < m_{ref} \leq 360$	340
$360 < m_{ref} \leq 395$	380
$395 < m_{ref} \leq 435$	410
$435 < m_{ref} \leq 480$	450
$480 < m_{ref} \leq 540$	510
$540 < m_{ref} \leq 600$	570
$600 < m_{ref} \leq 650$	620
$650 < m_{ref} \leq 710$	680
$710 < m_{ref} \leq 770$	740
$770 < m_{ref} \leq 820$	800
$820 < m_{ref} \leq 880$	850
$880 < m_{ref} \leq 940$	910
$940 < m_{ref} \leq 990$	960
$990 < m_{ref} \leq 1\ 050$	1\ 020
$1\ 050 < m_{ref} \leq 1\ 110$	1\ 080
$1\ 110 < m_{ref} \leq 1\ 160$	1\ 130

Status: Point in time view as at 16/12/2013.

Changes to legislation: There are currently no known outstanding effects for the Commission Delegated Regulation (EU) No 134/2014. (See end of Document for details)

$1\ 160 < m_{\text{ref}} \leq 1\ 220$	1 190
$1\ 220 < m_{\text{ref}} \leq 1\ 280$	1 250
$1\ 280 < m_{\text{ref}} \leq 1\ 330$	1 300
$1\ 330 < m_{\text{ref}} \leq 1\ 390$	1 360
$1\ 390 < m_{\text{ref}} \leq 1\ 450$	1 420
$1\ 450 < m_{\text{ref}} \leq 1\ 500$	1 470
$1\ 500 < m_{\text{ref}} \leq 1\ 560$	1 530
$1\ 560 < m_{\text{ref}} \leq 1\ 620$	1 590
$1\ 620 < m_{\text{ref}} \leq 1\ 670$	1 640
$1\ 670 < m_{\text{ref}} \leq 1\ 730$	1 700
$1\ 730 < m_{\text{ref}} \leq 1\ 790$	1 760
$1\ 790 < m_{\text{ref}} \leq 1\ 870$	1 810
$1\ 870 < m_{\text{ref}} \leq 1\ 980$	1 930
$1\ 980 < m_{\text{ref}} \leq 2\ 100$	2 040
$2\ 100 < m_{\text{ref}} \leq 2\ 210$	2 150
$2\ 210 < m_{\text{ref}} \leq 2\ 320$	2 270
$2\ 320 < m_{\text{ref}} \leq 2\ 440$	2 380
$2\ 440 < RM$	2 490

- 3.2.2.4. Bring the vehicle and the chassis dynamometer to the stabilised operating temperature, in order to approximate the road conditions.
- 3.2.2.5. Carry out the operations specified in point 3.1.2., with the exception of those in points 3.1.2.4. and 3.1.2.5.
- 3.2.2.6. Adjust the brake to reproduce the corrected running resistance (see point 3.1.2.8.) and to take into account the reference mass. This may be done by calculating the mean corrected road coast-down time from v_1 to v_2 and reproducing the same time on the dynamometer as follows:

Equation Ap 8-8:

$$t_{\text{corrected}} = m_{\text{ref}} \times \frac{2 \times \Delta v}{F_{\text{corrected}}} \times \frac{1}{3,6}$$

- 3.2.2.7. The power P_a to be absorbed by the bench shall be determined in order to enable the same total road load power to be reproduced for the same vehicle on different days or on different chassis dynamometers of the same type.

Status: Point in time view as at 16/12/2013.

Changes to legislation: There are currently no known outstanding effects for the Commission Delegated Regulation (EU) No 134/2014. (See end of Document for details)

Appendix 9

Explanatory note on the gearshift procedure for a type I test

0. Introduction

This explanatory note explains matters specified or described in this Regulation, including its Annexes or Appendices, and matters related thereto with regard to the gearshift procedure.

1. Approach

- 1.1. The development of the gearshift procedure was based on an analysis of the gearshift points in the in-use data. In order to establish generalised correlations between technical specifications of the vehicles and gearshift speeds, the engine speeds were normalised to the utilisable band between rated speed and idling speed.
- 1.2. In a second step, the end speeds (vehicle speed as well as normalised engine speed) for upshifts and downshifts were determined and recorded in a separate table. The averages of these speeds for each gear and vehicle were calculated and correlated with the vehicles' technical specifications.
- 1.3. The results of these analyses and calculations can be summarised as follows:
 - (a) the gearshift behaviour is engine-speed-related rather than vehicle-speed-related;
 - (b) the best correlation between gearshift speeds and technical data was found for normalised engine speeds and the power-to-mass ratio (maximum continuous rated power/(mass in running order + 75 kg));
 - (c) the residual variations cannot be explained by other technical data or by different drive train ratios. They are most probably due to differences in traffic conditions and individual driver behaviour;
 - (d) the best approximation between gearshift speeds and power-to-mass ratio was found for exponential functions;
 - (e) the gearshift mathematical function for the first gear is significantly lower than for all other gears;
 - (f) the gearshift speeds for all other gears can be approximated by one common mathematical function;
 - (g) no differences were found between five-speed and six-speed gearboxes;
 - (h) gearshift behaviour in Japan is significantly different from the equal-type gearshift behaviour in the European Union (EU) and in the United States of America (USA).
- 1.4. In order to find a balanced compromise between the three regions, a new approximation function for normalised upshift speeds versus power-to-mass ratio was calculated as a weighted average of the EU/USA curve (with 2/3 weighting) and the Japanese curve (with 1/3 weighting), resulting in the following equations for normalised engine upshift speeds:

Equation Ap9-1: Normalised upshift speed in 1st gear (gear 1)

$$n_{\max_acc}(1) = \left(0,5753 \times e^{\left(-1,9 \times \frac{P_h}{m_k + 75} \right)} - 0,1 \right) \times (s - n_{idle}) + n_{idle}$$

Equation Ap9-2: Normalised upshift speed in gears > 1

Status: Point in time view as at 16/12/2013.

Changes to legislation: There are currently no known outstanding effects for the Commission Delegated Regulation (EU) No 134/2014. (See end of Document for details)

$$n_{\max_acc}(i) = \left(0,5753 \times e^{\left(-1,9 \times \frac{r_n}{m_k + 75} \right)} \right) \times (s - n_{idle}) + n_{idle}$$

2. Calculation example

2.1 Figure Ap 9-1 shows an example of gearshift use for a small vehicle:

- (a) the lines in bold show the gear use for acceleration phases;
- (b) the dotted lines show the downshift points for deceleration phases;
- (c) in the cruising phases, the whole speed range between downshift speed and upshift speed may be used.

2.2 Where vehicle speed increases gradually during cruise phases, upshift speeds (v_{1-2} , v_{2-3} and v_{i-i+1}) in km/h may be calculated using the following equations:

Equation Ap9-3:

$$v_{1-2} = [0,03 \times (s - n_{idle}) + n_{idle}] \times \frac{1}{ndv_2}$$

Equation Ap9-4:

$$v_{2-3} = \left[\left(0,5753 \times e^{\left(-1,9 \times \frac{r_n}{m_k + 75} \right)} - 0,1 \right) \times (s - n_{idle}) + n_{idle} \right] \times \frac{1}{ndv_1}$$

Equation Ap9-5:

$$v_{i-i+1} = \left[\left(0,5753 \times e^{\left(-1,9 \times \frac{r_n}{m_k + 75} \right)} \right) \times (s - n_{idle}) + n_{idle} \right] \times \frac{1}{ndv_{i-1}}$$

, i = 3 to ng

Figure Ap9-1

Example of a gearshift sketch — Gear use during deceleration and cruise phases

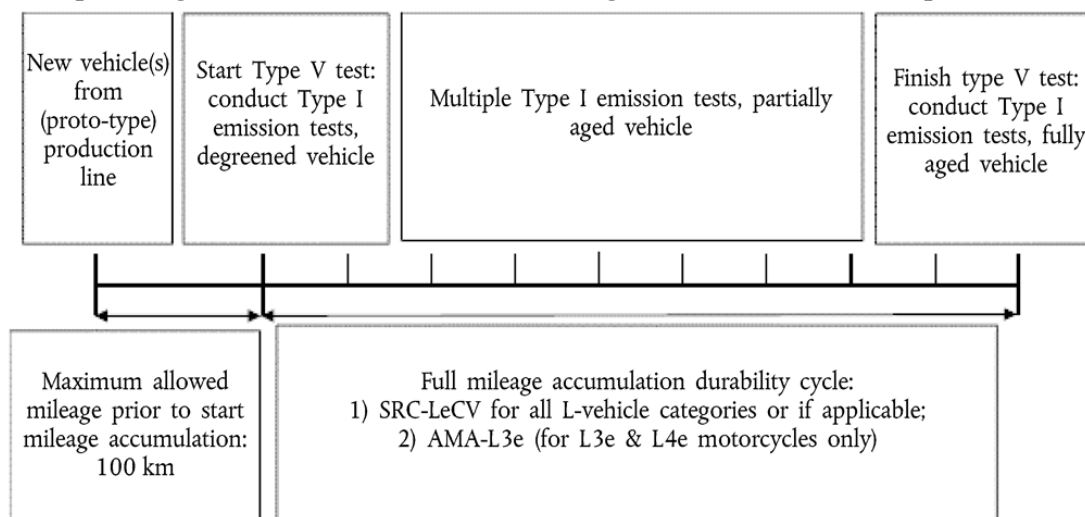

Gear use during acceleration phases

Status: Point in time view as at 16/12/2013.

Changes to legislation: There are currently no known outstanding effects for the Commission Delegated Regulation (EU) No 134/2014. (See end of Document for details)

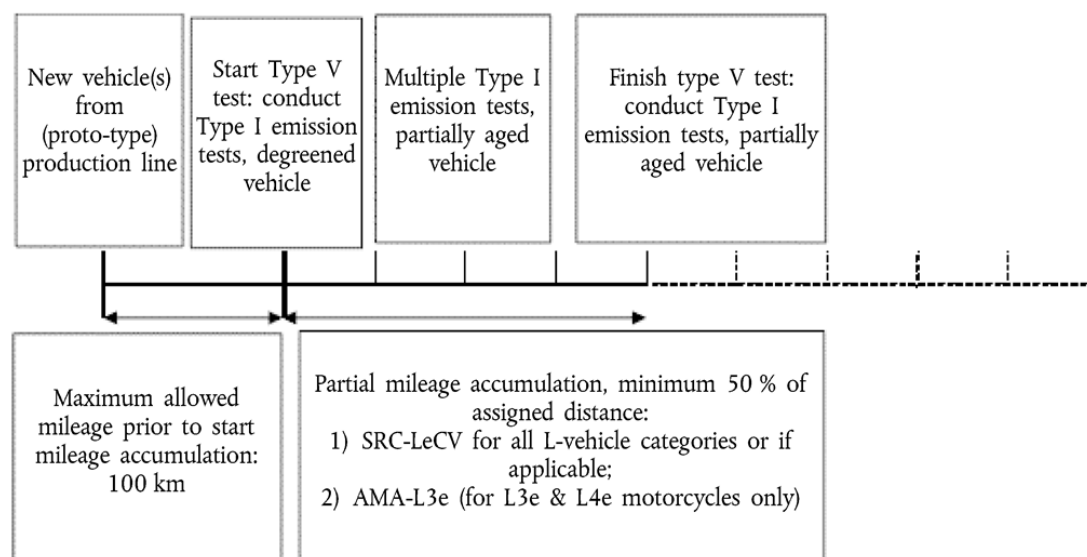

In order to allow the technical service more flexibility and to ensure driveability, the gearshift regression functions should be considered as lower limits. Higher engine speeds are permitted in any cycle phase.

3. Phase indicators

- 3.1 In order to avoid different interpretations in the application of the gearshift equations and thus to improve the comparability of the test, fixed-phase indicators are assigned to the speed pattern of the cycles. The specification of the phase indicators is based on the definition from the Japan Automobile Research Institute (JARI) of the four driving modes as shown in the following table:

TABLE AP9-1

Definition of driving modes

4 modes	Definition
Idle mode	vehicle speed < 5 km/h and -0,5 km/h/s (-0,139 m/s ²) < acceleration < 0,5 km/h/s (0,139 m/s ²)
Acceleration mode	acceleration > 0,5 km/h/s (0,139 m/s ²)
Deceleration mode	acceleration < - 0,5 km/h/s (- 0,139 m/s ²)
Cruise mode	vehicle speed ≥ 5 km/h and -0,5 km/h/s (-0,139 m/s ²) < acceleration < 0,5 km/h/s (0,139 m/s ²)

- 3.2 The indicators were then modified in order to avoid frequent changes during relatively homogeneous cycle parts and thus improve driveability. Figure Ap9-2 shows an example from cycle part 1.

Figure Ap9-2

Status: Point in time view as at 16/12/2013.

Changes to legislation: There are currently no known outstanding effects for the Commission Delegated Regulation (EU) No 134/2014. (See end of Document for details)

Example for modified phase indicators

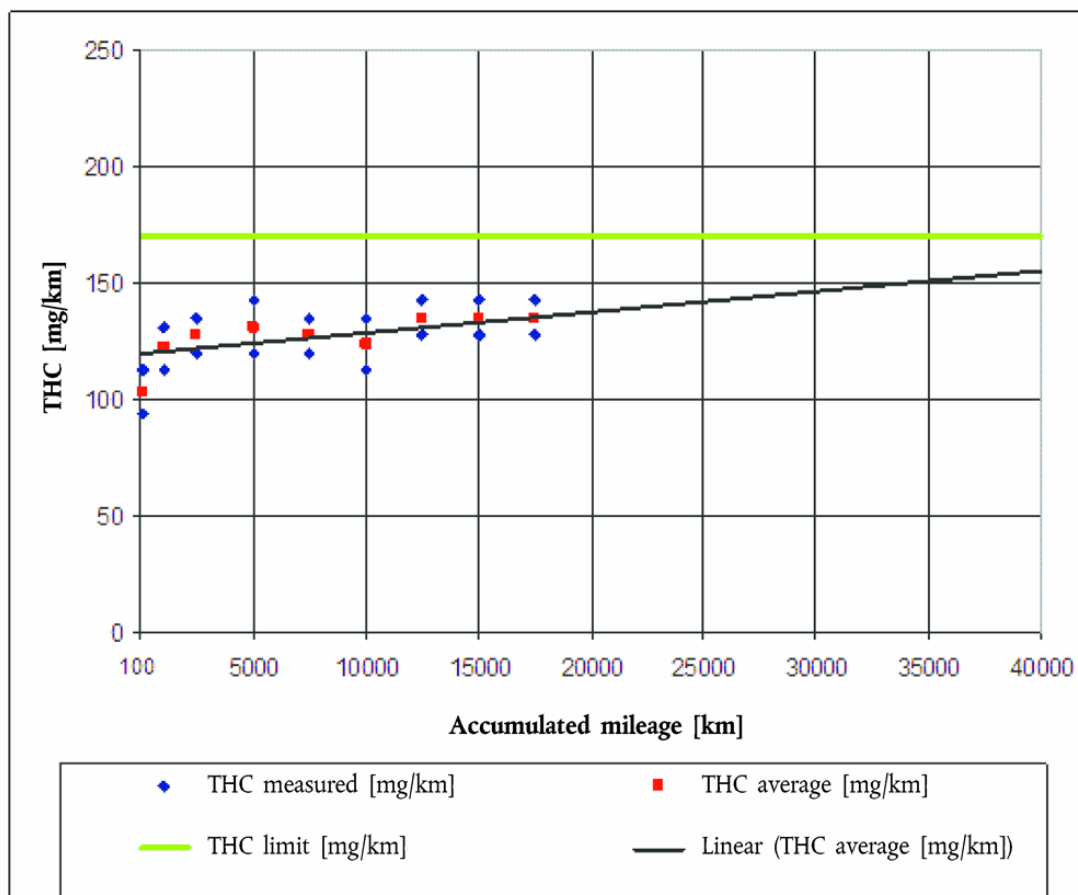

4. Calculation example

4.1. An example of input data necessary for the calculation of shift speeds is shown in Table Ap 9-2. The upshift speeds for acceleration phases for first gear and higher gears are calculated using Equations 9-1 and 9-2. The denormalisation of engine speeds can be performed using the equation

$$n = n_{norm} \times (s - n_{s,de}) + n_{s,de}$$

4.2. The downshift speeds for deceleration phases can be calculated using Equations 9-3 and 9-4. The ndv values in Table Ap 9-2 can be used as gear ratios. These values can also be used to calculate the corresponding vehicle speeds (

$$\text{vehicle shift speed in gear } i = \text{engine shift speed in gear } i / \text{ndvi}$$

. The results are shown in Tables Ap9-3 and Ap9-4.

4.3. Additional analyses and calculations were conducted to investigate whether these gearshift algorithms could be simplified and, in particular, whether engine shift speeds could be replaced by vehicle shift speeds. The analysis showed that vehicle speeds could not be brought in line with the gearshift behaviour of the in-use data.

4.3.1. *TABLE AP9-2*

Input data for the calculation of engine and vehicle shift speeds

Status: Point in time view as at 16/12/2013.

Changes to legislation: There are currently no known outstanding effects for the Commission Delegated Regulation (EU) No 134/2014. (See end of Document for details)

Item	Input data
Engine capacity in cm ³	600
Pn in kW	72
mk in kg	199
s in min ⁻¹	11 800
nidle in min ⁻¹	1 150
ndv ₁ ^a	133,66
ndv ₂	94,91
ndv ₃	76,16
ndv ₄	65,69
ndv ₅	58,85
ndv ₆	54,04
pmr ^b in kW/t	262,8

a ndv means the ratio between engine speed in min⁻¹ and vehicle speed in km/h

b pmr means the power-to-mass ratio calculated by

1. $Pn / (mk+75) \cdot 1\,000$; Pn in kW, mk in kg

4.3.2.

TABLE AP9-3

Shift speeds for acceleration phases for first gear and for higher gears (see Table Ap9-1)

	EU/USA/JAPAN DRIVING BEHAVIOUR	
	EU/USA/Japan driving behaviour	n_acc_max (1) n_acc_max (i)
n_norm ^a in percent	24,9	34,9
n in min ⁻¹	3 804	4 869

a n_norm means the value calculated using equations Ap9-1 and Ap9-2.

4.3.3.

TABLE AP9-4

Engine and vehicle shift speeds based on Table Ap9-2

Gearshift		EU/USA/Japan driving behaviour		
		v in km/h	n_norm (i) in percent	n in min ⁻¹
Upshift	1→2	28,5	24,9	3 804
	2→3	51,3	34,9	4 869
	3→4	63,9	34,9	4 869
	4→5	74,1	34,9	4 869
	5→6	82,7	34,9	4 869

a 'cl' means 'Clutch-Off' timing.

Status: Point in time view as at 16/12/2013.

Changes to legislation: There are currently no known outstanding effects for the Commission Delegated Regulation (EU) No 134/2014. (See end of Document for details)

Downshift	2→cl ^a	15,5	3,0	1 470
	3→2	28,5	9,6	2 167
	4→3	51,3	20,8	3 370
	5→4	63,9	24,5	3 762
	6→5	74,1	26,8	4 005

a 'cl' means 'Clutch-Off' timing.

Status: Point in time view as at 16/12/2013.

Changes to legislation: There are currently no known outstanding effects for the Commission Delegated Regulation (EU) No 134/2014. (See end of Document for details)

Appendix 10

Type-approval tests of a replacement pollution-control device type for L-category vehicles as separate technical units

1. Scope of the Appendix

This Appendix applies to the type-approval of separate technical units within the meaning of Article 23(10) of Regulation (EU) No 168/2013, of pollution-control devices to be fitted as replacement parts on one or more types of L-category vehicle.

2. Definitions

- 2.1. 'original equipment pollution-control devices' mean pollution-control devices including oxygen sensors, catalytic converter types, assemblies of catalytic converters, particulate filters or carbon canisters for evaporative emission control covered by the type-approval and originally delivered for the approved vehicle;
- 2.2. 'replacement pollution-control devices' means pollution-control devices including oxygen sensors, catalytic converter types, assemblies of catalytic converters, particulate filters or carbon canisters for evaporative emission control intended to replace an original equipment pollution-control device on a vehicle type with regard to environmental and propulsion unit performance approved in accordance with this Appendix and which can be type-approved as a separate technical unit in accordance with Regulation (EU) No 168/2013;

3. Application for environmental performance type-approval

- 3.1. Applications for type-approval of a type of replacement pollution-control device as a separate technical unit shall be submitted by the manufacturer of the system or by his authorised representative.
- 3.2. A model for the information document is referred to in Article 27(4) of Regulation (EU) No 168/2013.
- 3.3. For each type of replacement pollution-control device for which approval is requested, the type-approval application shall be accompanied by the following documents in triplicate, and by the following particulars:
 - 3.3.1. A description of the types of vehicles for which the device is intended, in terms of its characteristics;
 - 3.3.2. The numbers or symbols specific to the propulsion and vehicle type;
 - 3.3.3. Description of the replacement catalytic converter type stating the relative position of each of its components, together with the fitting instructions;
 - 3.3.4. Drawings of each component to facilitate location and identification, and statement of materials used. These drawings shall also indicate the intended location of the mandatory type-approval mark.
- 3.4. The following shall be submitted to the technical service responsible for the type-approval test:
 - 3.4.1. Vehicle(s) of a type approved in accordance with this Appendix equipped with a new original equipment pollution-control device type. This (these) vehicles shall be

selected by the applicant with the agreement of the technical service to the satisfaction of the approval authority. It (they) shall comply with the requirements of Annex II, type I test.

3.4.2. The test vehicles shall be without emission-control system defects and be properly maintained and used; any excessively worn out or malfunctioning emission-related original part shall be repaired or replaced. The test vehicles shall be tuned properly and set to the manufacturer's specification prior to emission testing.

3.4.3. One sample of the type of the replacement pollution-control device type. This sample shall be clearly and indelibly marked with the applicant's trade name or mark and its commercial designation.

4. Requirements

4.1. General requirements

The design, construction and mounting of the replacement pollution-control device type shall be such that:

4.1.1. the vehicle complies with the requirements of this Regulation under normal conditions of use, and in particular regardless of any vibrations to which it may be subjected;

4.1.2. the replacement pollution-control device displays reasonable resistance to the corrosion phenomena to which it is exposed, with due regard to the normal conditions of use of the vehicle;

4.1.3. the ground clearance available with the original equipment pollution-control device type and the angle at which the vehicle can lean over are not reduced;

4.1.4. the surface of the device does not reach unduly high temperatures;

4.1.5. the outline of the device has no projections or sharp edges;

4.1.6. shock absorbers and suspension have adequate clearance;

4.1.7. adequate safety clearance is provided for pipes;

4.1.8. the replacement pollution-control device is impact-resistant in a way that is compatible with clearly-defined maintenance and installation requirements;

4.1.9. if the original equipment pollution-control includes thermal protection, the replacement pollution-control device shall include equivalent protection;

4.1.10. if (an) oxygen probe(s) and other sensors or actuators are originally installed on the exhaust line, the replacement pollution-control device type shall be installed at exactly the same position as the original equipment pollution-control device and the position on the exhaust line of the oxygen probe(s) and other sensors or actuators shall not be modified.

4.2. Requirements regarding emissions

4.2.1. The vehicle referred to in point 3.4.1, equipped with a replacement pollution-control device of the type for which type-approval is requested, shall undergo the tests laid down in Annexes II and VI (depending on the type-approval of the vehicle)⁽⁷⁾.

4.2.1.1. Evaluation of pollutant emissions from vehicles equipped with replacement pollution-control devices

Status: Point in time view as at 16/12/2013.

Changes to legislation: There are currently no known outstanding effects for the Commission Delegated Regulation (EU) No 134/2014. (See end of Document for details)

Requirements regarding tailpipe or evaporative emissions are deemed to be complied with if the test vehicle equipped with the replacement pollutant-control device complies with the limit values in Annex VI to Regulation (EU) No 168/2013 (according to the type-approval of the vehicle)⁽⁷⁾.

- 4.2.1.2. Where the type-approval application is for different types of vehicles from the same manufacturer, the type I test may be limited to as few as two vehicles selected after agreement with the technical service to the satisfaction of the approval authority, provided that the different types of vehicle are fitted with the same type of original equipment pollution-control device.

4.2.2. Requirements regarding permissible sound level

The vehicles referred to in point 3.4.1, equipped with a replacement pollution-control device type that could allow worse noise emissions than the type for which type-approval is requested, shall satisfy the requirements of Annex IX (according to the type-approval of the vehicle)⁽⁷⁾. The test result for the vehicle in motion and for the stationary test shall be mentioned in the test report.

4.3. Testing of the propulsion performance of the vehicle

- 4.3.1. The replacement pollution-control device type shall be such as to ensure that the propulsion performance of the vehicle is comparable with that achieved with the original equipment pollution-control device type.

- 4.3.2. The propulsion performance of the vehicle equipped with the replacement pollution-control device shall be compared with that of an original equipment pollution-control device, also in new condition, fitted in turn to the vehicle referred to in point 3.4.1.

- 4.3.3. This test is carried out according to the applicable procedure set out in Annex X. The maximum net power and torque as well as the maximum attainable vehicle speed, if applicable, measured with the replacement pollution-control device, shall not deviate by more than + 5 % from those measured under the same conditions with the type-approved original equipment pollution-control device type.

Status: Point in time view as at 16/12/2013.

Changes to legislation: There are currently no known outstanding effects for the Commission Delegated Regulation (EU) No 134/2014. (See end of Document for details)

Appendix 11

Type I test procedure for hybrid L-category vehicles

1. Introduction

- 1.1. This Appendix defines the specific provisions regarding type-approval of hybrid electric L-category vehicles (HEV).
- 1.2. In principle, for the environmental type I to IX tests, hybrid electric vehicles shall be tested in accordance with this Regulation, unless otherwise provided for in this Appendix.
- 1.3. For the type I and type VII tests, off-vehicle charging (OVC) vehicles (as categorised in point 2) shall be tested according to Conditions A and B. Both sets of test results and the weighted values shall be reported in the test report drafted in accordance with the template referred to in Article 32(1) of Regulation (EU) No 168/2013.
- 1.4. The emissions test results shall comply with the limits set-out in Regulation (EU) No 168/2013 under all test conditions specified in this Regulation.

2. Categories of hybrid vehicles

TABLE AP11-1

Hybrid vehicle categories

Vehicle charging	Off-Vehicle Charging ^a (OVC)		Not-off-vehicle Charging ^b (NOVC)	
	Without	With	Without	With
Operating mode switch				

^a Also known as 'externally chargeable'.

^b Also known as 'not externally chargeable'.

3. Type I test methods

For the type I test, hybrid electric L-category vehicles shall be tested according to the applicable procedure in Annex VI to Regulation (EU) No 168/2013. For each test condition, the pollutant emission test result shall comply with the limits in Parts A1 and A2 of Annex VI to Regulation (EU) No 168/2013, whichever is applicable in accordance with Annex IV to Regulation (EU) No 168/2013.

- 3.1. Externally chargeable vehicles (OVC HEVs) without an operating mode switch
 - 3.1.1. Two tests shall be performed under the following conditions:
 - (a) condition A: the test shall be carried out with a fully charged electrical energy/power storage device.
 - (b) condition B: the test shall be carried out with an electrical energy/power storage device in minimum state of charge (maximum discharge of capacity).

The profile of the state of charge (SOC) of the electrical energy/power storage device during different stages of the test is given in Appendix 3.1. to Annex VII.

Status: Point in time view as at 16/12/2013.

Changes to legislation: There are currently no known outstanding effects for the Commission Delegated Regulation (EU) No 134/2014. (See end of Document for details)

3.1.2. Condition A

3.1.2.1. The procedure shall start with the discharge of the electrical energy/power storage device of the vehicle while driving (on the test track, on a chassis dynamometer, etc.) in any of the following conditions:

- (a) at a steady speed of 50 km/h until the fuel-consuming engine starts up;
- (b) if a vehicle cannot reach a steady speed of 50 km/h without the fuel-consuming engine starting up, the speed shall be reduced until it can run at a lower steady speed at which the fuel-consuming engine does not start up for a defined time or distance (to be determined by the technical service and the manufacturer subject to the agreement of the approval authority);
- (c) in accordance with the manufacturer's recommendation.

The fuel-consuming engine shall be stopped within ten seconds of being automatically started.

3.1.2.2. Conditioning of vehicle

The vehicle shall be conditioned by driving the applicable type I driving cycle as set out in Appendix 6.

3.1.2.3. After this preconditioning and before testing, the vehicle shall be kept in a room in which the temperature remains relatively constant between 293,2 K and 303,2 K (20 °C and 30 °C). This conditioning shall be carried out for at least six hours and continue until the temperature of the engine oil and coolant, if any, are within ± 2 K of the temperature of the room, and the electrical energy/power storage device is fully charged as a result of the charging prescribed in point 3.1.2.4.

3.1.2.4. During soak, the electrical energy/power storage device shall be charged with any of the following:

- (a) the on-board charger if fitted;
- (b) an external charger recommended by the manufacturer and referred to in the user manual, using the normal overnight charging procedure set out in point 3.2.2.4. of Appendix 3 to Annex VII.

This procedure excludes all types of special charges that could be automatically or manually initiated, e.g. equalisation or servicing charges.

The manufacturer shall declare that a special charge procedure has not occurred during the test;

End-of-charge criterion.

The end-of-charge criterion corresponds to a charging time of 12 hours, except where the standard instrumentation gives the driver a clear indication that the electrical energy storage device is not yet fully charged.

In this case, the maximum time is = 3 times the claimed battery capacity (Wh) / mains power supply (W).

3.1.2.5. Test procedure

3.1.2.5.1. The vehicle shall be started up by the means provided to the driver for normal use. The first test cycle starts on the initiation of the vehicle start-up procedure.

Status: Point in time view as at 16/12/2013.

Changes to legislation: There are currently no known outstanding effects for the Commission Delegated Regulation (EU) No 134/2014. (See end of Document for details)

- 3.1.2.5.2. The test procedures described in points 3.1.2.5.2.1. or 3.1.2.5.2.2. shall be used in accordance with the type I test procedure set out in Appendix 6.
- 3.1.2.5.2. Sampling shall begin (BS) before or at the initiation of the vehicle start-up procedure and end on conclusion of the final idling period of the applicable type I test cycle (end of sampling (ES)).
- 3.1.2.5.2. Sampling shall begin (BS) before or at the initiation of the vehicle start-up procedure and continue over a number of repeat test cycles. It shall end on conclusion of the final idling period in the applicable type I test cycle during which the battery reached the minimum state of charge in accordance with the following procedure (end of sampling (ES)):
- 3.1.2.5.2. The electricity balance Q (Ah) is measured over each combined cycle according to the procedure in Appendix 3.2. to Annex VII and used to determine when the battery minimum state of charge has been reached;
- 3.1.2.5.2. The battery minimum state of charge is considered to have been reached in combined cycle N if the electricity balance Q measured during combined cycle N+1 is not more than a 3 percent discharge, expressed as a percentage of the nominal capacity of the battery (in Ah) in its maximum state of charge, as declared by the manufacturer. At the manufacturer's request, additional test cycles may be run and their results included in the calculations in points 3.1.2.5.5. and 3.1.4.2, provided that the electricity balance Q for each additional test cycle shows less discharge of the battery than over the previous cycle;
- 3.1.2.5.2. After each cycle, a hot soak period of up to ten minutes is allowed. The powertrain shall be switched off during this period.
- 3.1.2.5.3. The vehicle shall be driven according to the provisions in Appendix 6.
- 3.1.2.5.4. The exhaust gases shall be analysed according to the provisions in Annex II.
- 3.1.2.5.5. The test results shall be compared with the limits set out in Annex VI to Regulation (EU) No 168/2013 and the average emission of each pollutant (expressed in mg per kilometre) for Condition A shall be calculated (M_{1i}).

In the case of testing according to point 3.1.2.5.2.1., (M_{1i}) is the result of the single combined cycle run.

In the case of testing according to point 3.1.2.5.2.2., the test result of each combined cycle run (M_{1ia}), multiplied by the appropriate deterioration factor and K_i factors, shall be less than the limits in Part A of Annex VI to Regulation (EU) No 168/2013. For the purposes of the calculation in point 3.1.4., M_{1i} shall be defined as:

Equation Ap11-1:

$$M_{1i} = \frac{1}{N} \sum_{a=1}^N M_{1ia}$$

where:

i : pollutant
a : test cycle

3.1.3. Condition B

3.1.3.1. Conditioning of vehicle.

Status: Point in time view as at 16/12/2013.

Changes to legislation: There are currently no known outstanding effects for the Commission Delegated Regulation (EU) No 134/2014. (See end of Document for details)

The vehicle shall be conditioned by driving the applicable type I driving cycle as set out in Appendix 6.

3.1.3.2. The electrical energy/power storage device of the vehicle shall be discharged while driving (on the test track, on a chassis dynamometer, etc.):

- (a) at a steady speed of 50 km/h until the fuel-consuming engine starts up, or
- (b) if a vehicle cannot reach a steady speed of 50 km/h without the fuel-consuming engine starting up, the speed shall be reduced until it can run at a lower steady speed at which the engine does not start up for a defined time or distance (to be determined by the technical service and the manufacturer), or
- (c) in accordance with the manufacturers' recommendation.

The fuel-consuming engine shall be stopped within ten seconds of being automatically started.

3.1.3.3. After this preconditioning and before testing, the vehicle shall be kept in a room in which the temperature remains relatively constant between 293,2 K and 303,2 K (20 °C and 30 °C). This conditioning shall be carried out for at least six hours and continue until the temperature of the engine oil and coolant, if any, are within ± 2 K of the temperature of the room.

3.1.3.4. Test procedure

3.1.3.4.1. The vehicle shall be started up by the means provided to the driver for normal use. The first cycle starts on the initiation of the vehicle start-up procedure.

3.1.3.4.2. Sampling shall begin (BS) before or at the initiation of the vehicle start-up procedure and end on conclusion of the final idling period of the applicable type I test cycle (end of sampling (ES)).

3.1.3.4.3. The vehicle shall be driven according to the provisions of Appendix 6.

3.1.3.4.4. The exhaust gases shall be analysed in accordance with Annex II.

3.1.3.5. The test results shall be compared with the limits in Part A of Annex VI to Regulation (EU) No 168/2013 and the average emission of each pollutant for Condition B shall be calculated (M_{2i}). The test results M_{2i} , multiplied by the appropriate deterioration and K_i factors, shall be less than the limits prescribed in Part A of Annex VI to Regulation (EU) No 168/2013.

3.1.4. Test results

3.1.4.1. Testing in accordance with point 3.1.2.5.2.1.

For reporting, the weighted values shall be calculated as follows:

Equation Ap11-2:

$$M_i = (D_e \times M_{1i} + D_{av} \times M_{2i}) / (D_e + D_{av})$$

where:

- M_i = mass emission of the pollutant i in mg/km;
- M_{1i} = average mass emission of the pollutant i in mg/km with a fully charged electrical energy/power storage device, calculated in accordance with point 3.1.2.5.5.;

Status: Point in time view as at 16/12/2013.

Changes to legislation: There are currently no known outstanding effects for the Commission Delegated Regulation (EU) No 134/2014. (See end of Document for details)

M_{2i}	= average mass emission of the pollutant i in mg/km with an electrical energy/power storage device in minimum state of charge (maximum discharge of capacity), calculated in accordance with point 3.1.3.5.;
D_e	= electric range of the vehicle determined according to the procedure set out in Appendix 3.3. to Annex VII, where the manufacturer shall provide the means for taking the measurement with the vehicle running in pure electric mode;
D_{av}	= average distance between two battery recharges, as follows: <ul style="list-style-type: none"> — 4 km for a vehicle with an engine capacity $< 150 \text{ cm}^3$; — 6 km for a vehicle with an engine capacity $\geq 150 \text{ cm}^3$ and $v_{\max} < 130 \text{ km/h}$; — 10 km for a vehicle with an engine capacity $\geq 150 \text{ cm}^3$ and $v_{\max} \geq 130 \text{ km/h}$.

3.1.4.2. Testing in accordance with point 3.1.2.5.2.2.

For communication, the weighted values shall be calculated as follows:

Equation Ap11-3:

$$M_i = (D_{ovc} \times M_{1i} + D_{av} \times M_{2i}) / (D_{ovc} + D_{av})$$

where:

M_i	= mass emission of the pollutant i in mg/km;
M_{1i}	= average mass emission of the pollutant i in mg/km with a fully charged electrical energy/power storage device, calculated in accordance with point 3.1.2.5.5.;
M_{2i}	= average mass emission of the pollutant i in mg/km with an electrical energy/power storage device in minimum state of charge (maximum discharge of capacity), calculated in accordance with point 3.1.3.5.;
D_{ovc}	= OVC range established in accordance with the procedure in Appendix 3.3. to Annex VII;
D_{av}	= average distance between two battery recharges, as follows: <ul style="list-style-type: none"> — 4 km for a vehicle with an engine capacity $< 150 \text{ cm}^3$; — 6 km for a vehicle with an engine capacity $\geq 150 \text{ cm}^3$ and $v_{\max} < 130 \text{ km/h}$; — 10 km for a vehicle with an engine capacity $\geq 150 \text{ cm}^3$ and $v_{\max} \geq 130 \text{ km/h}$.

3.2. Externally chargeable vehicles (OVC HEVs) with an operating mode switch.

3.2.1. Two tests shall be performed under the following conditions:

3.2.1.1. Condition A: the test shall be carried out with a fully charged electrical energy/power storage device.

3.2.1.2. Condition B: the test shall be carried out with an electrical energy/power storage device in minimum state of charge (maximum discharge of capacity).

3.2.1.3. The operating mode switch shall be positioned in accordance with the table Ap11-2.

Status: Point in time view as at 16/12/2013.

Changes to legislation: There are currently no known outstanding effects for the Commission Delegated Regulation (EU) No 134/2014. (See end of Document for details)

TABLE AP11-2

Look-up table to determine Condition A or B depending on different hybrid vehicle concepts and on the hybrid mode selection switch position

	Hybrid-modes ->	Pure electricHybrid	Pure fuel-consumingHybrid	Pure electricPure fuel-consumingHybrid	Hybrid mode n ^a Hybrid mode m ¹
Battery state of charge		Switch in position	Switch in position	Switch in position	Switch in position
Condition A Fully charged		Hybrid	Hybrid	Most electric hybrid mode ^b	Hybrid
Condition B Min. state of charge		Fuel-consuming	Fuel-consuming	Most fuel-consuming mode ^c	Hybrid

a For instance: sport, economic, urban, extra-urban position, etc.

b Most electric hybrid mode: the hybrid mode which can be proven to have the highest electricity consumption of all selectable hybrid modes when tested in accordance with condition A of point 4 of Annex 10 to UNECE Regulation No 101, to be established based on information provided by the manufacturer and in agreement with the technical service.

c Most fuel-consuming mode: the hybrid mode which can be proven to have the highest fuel consumption of all selectable hybrid modes when tested in accordance with condition B of point 4 of Annex 10 to UNECE regulation No 101, to be established based on information provided by the manufacturer and in agreement with the technical service.

3.2.2. Condition A

3.2.2.1. If the pure electric range of the vehicle is higher than one complete cycle, the type I test may at the manufacturer's request be carried out in pure electric mode. In this case, the engine preconditioning prescribed in point 3.2.2.3.1. or 3.2.2.3.2. can be omitted.

3.2.2.2. The procedure shall start with the discharge of the electrical energy/power storage device of the vehicle while driving with the switch in pure electric position (on the test track, on a chassis dynamometer, etc.) at a steady speed of 70 percent \pm 5 percent of the maximum design speed of the vehicle, which is to be determined according to the test procedure set out in Appendix 1 to Annex X.

Stopping the discharge occurs in any of the following conditions:

- (a) when the vehicle is not able to run at 65 percent of the maximum thirty minutes speed;
- (b) when the standard on-board instrumentation gives the driver an indication to stop the vehicle;
- (c) after 100 km.

If the vehicle is not equipped with a pure electric mode, the electrical energy/power storage device shall be discharged by driving the vehicle (on the test track, on a chassis dynamometer, etc.) in any of the following conditions:

- (a) at a steady speed of 50 km/h until the fuel-consuming engine of the HEV starts up;
- (b) if a vehicle cannot reach a steady speed of 50 km/h without the fuel-consuming engine starting up, the speed shall be reduced until it can run at a lower steady speed at

Status: Point in time view as at 16/12/2013.

Changes to legislation: There are currently no known outstanding effects for the Commission Delegated Regulation (EU) No 134/2014. (See end of Document for details)

which the fuel-consuming engine does not start up for a defined time or distance (to be determined by the technical service and the manufacturer);

- (c) in accordance with the manufacturers' recommendation.

The fuel-consuming engine shall be stopped within ten seconds of being automatically started. By means of derogation if the manufacturer can prove to the technical service to the satisfaction of the approval authority that the vehicle is physically not capable of achieving the thirty minutes speed the maximum fifteen minute speed may be used instead.

3.2.2.3. Conditioning of vehicle

3.2.2.4. After this preconditioning and before testing, the vehicle shall be kept in a room in which the temperature remains relatively constant between 293,2 K and 303,2 K (20 °C and 30 °C). This conditioning shall be carried out for at least six hours and continue until the temperature of the engine oil and coolant, if any, are within ± 2 K of the temperature of the room, and the electrical energy/power storage device is fully charged as a result of the charging prescribed in point 3.2.2.5.

3.2.2.5. During soak, the electrical energy/power storage device shall be charged with any of the following chargers:

- (a) the on-board charger if fitted;
- (b) an external charger recommended by the manufacturer, using the normal overnight charging procedure.

This procedure excludes all types of special charges that could be automatically or manually initiated, e.g. equalisation charges or servicing charges.

The manufacturer shall declare that a special charge procedure has not occurred during the test.

- (c) End-of-charge criterion

The end-of-charge criterion corresponds to a charging time of 12 hours, except where the standard instrumentation gives the driver a clear indication that the electrical energy storage device is not yet fully charged.

In this case, the maximum time is $= 3 \times \text{claimed battery capacity (Wh)} / \text{mains power supply (W)}$.

3.2.2.6. Test procedure

3.2.2.6.1. The vehicle shall be started up by the means provided to the driver for normal use. The first cycle starts on the initiation of the vehicle start-up procedure.

3.2.2.6.1.1. Sampling shall begin (BS) before or at the initiation of the vehicle start-up procedure and end on conclusion of the final idling period of the applicable type I test cycle (end of sampling (ES)).

3.2.2.6.1.1.1. Sampling shall begin (BS) before or at the initiation of the vehicle start-up procedure and continue over a number of repeat test cycles. It shall end on conclusion of the final idling period of the applicable type I test cycle during which the battery has reached the minimum state of charge in accordance with the following procedure (end of sampling (ES)):

3.2.2.6.1.1.1.1. The electricity balance Q (Ah) is measured over each combined cycle using the procedure in Appendix 3.2. to Annex VII and used to determine when the battery minimum state of charge has been reached;

Status: Point in time view as at 16/12/2013.

Changes to legislation: There are currently no known outstanding effects for the Commission Delegated Regulation (EU) No 134/2014. (See end of Document for details)

- 3.2.2.6.1. The battery minimum state of charge is considered to have been reached in combined cycle N if the electricity balance measured during combined cycle N+1 is not more than a 3 percent discharge, expressed as a percentage of the nominal capacity of the battery (in Ah) in its maximum state of charge, as declared by the manufacturer. At the manufacturer's request, additional test cycles may be run and their results included in the calculations in points 3.2.2.7. and 3.2.4.3., provided that the electricity balance for each additional test cycle shows less discharge of the battery than over the previous cycle;
- 3.2.2.6.1. After each cycle, a hot soak period of up to ten minutes is allowed. The powertrain shall be switched off during this period.
- 3.2.2.6.2. The vehicle shall be driven according to the provisions of Appendix 6.
- 3.2.2.6.3. The exhaust gases shall be analysed according to Annex II.
- 3.2.2.7. The test results shall be compared to the emission limits set out in Annex VI(A) to Regulation (EU) No 168/2013 and the average emission of each pollutant (expressed in mg/km) for Condition A shall be calculated (M_{1i}).

The test result of each combined cycle run M_{1ia} , multiplied by the appropriate deterioration and K_i factors, shall be less than the emission limits in Part A or B of Annex VI to Regulation (EU) No 168/2013. For the purposes of the calculation in point 3.2.4., M_{1i} shall be calculated according to Equation Ap11-1.

3.2.3. Condition B

3.2.3.1. Conditioning of vehicle.

The vehicle shall be conditioned by driving the applicable type I driving cycle set out in Appendix 6.

- 3.2.3.2. The electrical energy/power storage device of the vehicle shall be discharged in accordance with point 3.2.2.2.
- 3.2.3.3. After this preconditioning, and before testing, the vehicle shall be kept in a room in which the temperature remains relatively constant between 293,2 K and 303,2 K (20 °C and 30 °C). This conditioning shall be carried out for at least six hours and continue until the temperature of the engine oil and coolant, if any, are within ± 2 K of the temperature of the room.
- 3.2.3.4. Test procedure
- 3.2.3.4.1. The vehicle shall be started up by the means provided to the driver for normal use. The first cycle starts on the initiation of the vehicle start-up procedure.
- 3.2.3.4.2. Sampling shall begin (BS) before or at the initiation of the vehicle start-up procedure and end on conclusion of the final idling period of the applicable type I test cycle (end of sampling (ES)).
- 3.2.3.4.3. The vehicle shall be driven in accordance with the provisions of Appendix 6.
- 3.2.3.4.4. The exhaust gases shall be analysed in accordance with the provisions in Annex II.
- 3.2.3.5. The test results shall be compared with the pollutant limits in Annex VI to Regulation (EU) No 168/2013 and the average emission of each pollutant for Condition B shall be calculated (M_{2i}). The test results M_{2i} , multiplied by the appropriate deterioration and K_i factors, shall be less than the limits in Annex VI to Regulation (EU) No 168/2013.

Status: Point in time view as at 16/12/2013.

Changes to legislation: There are currently no known outstanding effects for the Commission Delegated Regulation (EU) No 134/2014. (See end of Document for details)

3.2.4. Test results

3.2.4.1. Testing in accordance with point 3.2.2.6.2.1.

For communication, the weighted values shall be calculated as in Equation Ap11-2

where:

M_i	= mass emission of the pollutant i in mg/km;
M_{1i}	= average mass emission of the pollutant i in mg/km with a fully charged electrical energy/power storage device, calculated in accordance with point 3.2.2.7.;
M_{2i}	= average mass emission of the pollutant i in mg/km with an electrical energy/power storage device in minimum state of charge (maximum discharge of capacity), calculated in accordance with point 3.2.3.5;
D_e	= electric range of the vehicle with the switch in pure electric position, in accordance with Appendix 3.3. to Annex VII. If there is not a pure electric position, the manufacturer shall provide the means for taking the measurement with the vehicle running in pure electric mode.
D_{av}	= average distance between two battery recharges, as follows: <ul style="list-style-type: none"> — 4 km for a vehicle with an engine capacity $< 150 \text{ cm}^3$; — 6 km for a vehicle with an engine capacity $\geq 150 \text{ cm}^3$ and $v_{\max} < 130 \text{ km/h}$; — 10 km for a vehicle with an engine capacity $\geq 150 \text{ cm}^3$ and $v_{\max} \geq 130 \text{ km/h}$.

3.2.4.2. Testing in accordance with point 3.2.2.6.2.2.

For communication, the weighted values shall be calculated as in Equation Ap11-3

where:

M_i	= mass emission of the pollutant i in mg/km;
M_{1i}	= average mass emission of the pollutant i in mg/km with a fully charged electrical energy/power storage device, calculated in accordance with point 3.2.2.7.;
M_{2i}	= average mass emission of the pollutant i in mg/km with an electrical energy/power storage device in minimum state of charge (maximum discharge of capacity), calculated in accordance with point 3.2.3.5.;
D_{ovc}	= OVC range according to the procedure in Appendix 3.3. to Annex VII;
D_{av}	= average distance between two battery recharges, as follows: <ul style="list-style-type: none"> — 4 km for a vehicle with an engine capacity $< 150 \text{ cm}^3$; — 6 km for a vehicle with an engine capacity $\geq 150 \text{ cm}^3$ and $v_{\max} < 130 \text{ km/h}$; — 10 km for a vehicle with an engine capacity $\geq 150 \text{ cm}^3$ and $v_{\max} \geq 130 \text{ km/h}$.

3.3. Not externally chargeable vehicles (not-OVC HEVs) without an operating mode switch

3.3.1. These vehicles shall be tested according to Appendix 6.

Status: Point in time view as at 16/12/2013.

Changes to legislation: There are currently no known outstanding effects for the Commission Delegated Regulation (EU) No 134/2014. (See end of Document for details)

- 3.3.2. For preconditioning, at least two consecutive complete driving cycles are carried out without soak.
- 3.3.3. The vehicle shall be driven in accordance with to the provisions of Appendix 6.
- 3.4. Not externally chargeable vehicles (not-OVC HEVs) with an operating mode switch
 - 3.4.1. These vehicles are preconditioned and tested in hybrid mode in accordance with Annex II. If several hybrid modes are available, the test shall be carried out in the mode that is automatically set after the ignition key is turned (normal mode). On the basis of information provided by the manufacturer, the technical service shall ensure that the limit values are complied with in all hybrid modes.
 - 3.4.2. For preconditioning, at least two consecutive complete applicable driving cycles shall be carried out without soak.
 - 3.4.3. The vehicle shall be driven in accordance with the provisions of Annex II.

Appendix 12

Type I test procedure for L-category vehicles fuelled with LPG, NG/biomethane, flex fuel H₂NG or hydrogen

1. Introduction

- 1.1. This Appendix describes the special requirements as regards the testing of LPG, NG/biomethane, H₂NG or hydrogen gas for the approval of alternative fuel vehicles that run on those fuels or can run on petrol, LPG, NG/biomethane, H₂NG or hydrogen.
- 1.2. The composition of these gaseous fuels, as sold on the market, can vary greatly and fuelling systems must adapt their fuelling rates accordingly. To demonstrate this adaptability, the parent vehicle equipped with a representative LPG, NG/biomethane or H₂NG fuel system shall be tested in type I tests on two extreme reference fuels.
- 1.3. The requirements of this Appendix as regards hydrogen shall apply only to vehicles using hydrogen as a combustion fuel and not to those equipped with a fuel cell operating on hydrogen.

2. Granting of type-approval for an L-category vehicle equipped with a gaseous fuel system

Type-approval is granted subject to the following requirements:

2.1. Exhaust emissions approval of a vehicle equipped with a gaseous fuel system

It shall be demonstrated that the parent vehicle equipped with a representative LPG, NG/biomethane, H₂NG or hydrogen fuel system can adapt to any fuel composition that may appear on the market and comply with the following:

- 2.1.1. In the case of LPG there are variations in C₃/C₄ composition (test fuel requirement A and B) and therefore the parent vehicle shall be tested on reference fuels A and B referred to in Appendix 2;
- 2.1.2. In the case of NG/biomethane there are generally two types of fuel, high calorific fuel (G20) and low calorific fuel (G25), but with a significant spread within both ranges; they differ significantly in Wobbe index. These variations are reflected in the reference fuels. The parent vehicle shall be tested on both reference fuels referred to in Appendix 2;
- 2.1.3. In the case of a flex fuel H₂NG vehicle, the composition range may vary from 0 % hydrogen (L-gas) to a maximum percentage of hydrogen within the mixture (H-gas), as specified by the manufacturer. It shall be demonstrated that the parent vehicle can adapt to any percentage within the range specified by the manufacturer and the vehicle shall be tested in the type I test on 100 % H-gas and 100 % L-gas. It shall also be demonstrated that it can adapt to any NG/biomethane composition that may appear on the market, regardless of the percentage of hydrogen in the mixture.
- 2.1.4. For vehicles equipped with hydrogen fuel systems, compliance shall be tested on the single hydrogen reference fuel referred to in Appendix 2.
- 2.1.5. If the transition from one fuel to another is in practice aided through the use of a switch, this switch shall not be used during type-approval. In such cases, at the manufacturer's

Status: Point in time view as at 16/12/2013.

Changes to legislation: There are currently no known outstanding effects for the Commission Delegated Regulation (EU) No 134/2014. (See end of Document for details)

request and with the agreement of the technical service, the pre-conditioning cycle referred in point 5.2.4 of Annex II may be extended.

2.1.6. The ratio of emission results 'r' shall be determined for each pollutant as shown in Table Ap12-1 for LPG, NG/biomethane and H₂NG vehicles.

2.1.6.1. In the case of LPG and NG/biomethane vehicles, the ratios of emission results 'r' shall be determined for each pollutant as follows:

Table Ap12-1

Calculation ratio 'r' for LPG and NG/biomethane vehicles

Type(s) of fuel	Reference fuels	Calculation of 'r'
LPG and petrol (Approval B)	Fuel A	$r = \frac{B}{A}$
or LPG only (Approval D)	Fuel B	
NG/biomethane	fuel G20	$r = \frac{G25}{G20}$
	fuel G25	

2.1.6.2. In the case of flex fuel H₂NG vehicles, two ratios of emission results 'r₁' and 'r₂' shall be determined for each pollutant as follows:

Table Ap12-2

Look-up table ratio 'r' for NG/biomethane or H₂NG gaseous fuels

Type(s) of fuel	Reference fuels	Calculation of 'r'
NG/biomethane	fuel G20	$r_1 = \frac{G25}{G20}$
	fuel G25	
H ₂ NG	Mixture of hydrogen and G20 with the maximum percentage of hydrogen specified by the manufacturer	$r_2 = \frac{H_2 G25}{H_2 G20}$
	Mixture of hydrogen and G25 with the maximum percentage of hydrogen specified by the manufacturer	

2.2. Exhaust emissions approval of a member of the propulsion family

For the type-approval of mono-fuel gas vehicles and bi-fuel vehicles operating in gas mode, fuelled by LPG, NG/biomethane, H₂NG or hydrogen, as a member of the propulsion family in Annex XI, a type I test shall be performed with one gaseous reference fuel. For LPG, NG/biomethane and H₂NG vehicles, this reference fuel may be either of the reference fuels in Appendix 2. The gas-fuelled vehicle is considered to comply if the following requirements are met:

Status: Point in time view as at 16/12/2013.

Changes to legislation: There are currently no known outstanding effects for the Commission Delegated Regulation (EU) No 134/2014. (See end of Document for details)

- 2.2.1. The test vehicle shall comply with the definition of a propulsion family member in Annex XI.
- 2.2.2. If the test fuel requirement is reference fuel A for LPG or G20 for NG/biomethane, the emission result shall be multiplied by the relevant factor 'r' if $r > 1$; if $r < 1$, no correction is needed.
- 2.2.3. If the test fuel requirement is reference fuel B for LPG or G25 for NG/biomethane, the emission result shall be divided by the relevant factor 'r' if $r < 1$; if $r > 1$, no correction is needed.
- 2.2.4. At the manufacturer's request, the type I test may be performed on both reference fuels, so that no correction is needed.
- 2.2.5. The parent vehicle shall comply with the emission limits for the relevant category set out in Annex VI(A) to Regulation (EU) No 168/2013 and for both measured and calculated emissions.
- 2.2.6. If repeated tests are conducted on the same engine, an average shall first be taken of the results on reference fuel G20, or A, and those on reference fuel G25, or B; the 'r' factor shall then be calculated from these averages.
- 2.2.7. For the type-approval of a flex fuel H₂NG vehicle as a member of a family, two type I tests shall be performed, the first test with 100 % of either G20 or G25, and the second test with the mixture of hydrogen and the same NG/biomethane fuel used during the first test, with the maximum hydrogen percentage specified by the manufacturer.
 - 2.2.7.1. If the NG/biomethane fuel is the reference fuel G20, the emission result for each pollutant shall be multiplied by the relevant factors (r_1 for the first test and r_2 for the second test) in point 2.1.6. if the relevant factor > 1 ; if the correspondent relevant factor < 1 , no correction is needed.
 - 2.2.7.2. If the NG/biomethane fuel is the reference fuel G25, the emission result for each pollutant shall be divided by the corresponding relevant factor (r_1 for the first test and r_2 for the second test) calculated in accordance with point 2.1.6., if this is < 1 ; if the corresponding relevant factor > 1 , no correction is needed.
 - 2.2.7.3. At the manufacturer's request, the type I test shall be conducted with the four possible combinations of reference fuels, in accordance with point 2.1.6., so that no correction is needed.
 - 2.2.7.4. If repeated tests are carried out on the same engine, an average shall first be taken of the results on reference fuel G20, or H₂G20, and those on reference fuel G25, or H₂G25 with the maximum hydrogen percentage specified by the manufacturer; the 'r₁' and 'r₂' factors shall then be calculated from these averages.
- 2.2.8. During the type I test, the vehicle shall use only petrol for a maximum of 60 consecutive seconds directly after engine crank and start when operating in gas-fuelling mode.

Status: Point in time view as at 16/12/2013.

Changes to legislation: There are currently no known outstanding effects for the Commission Delegated Regulation (EU) No 134/2014. (See end of Document for details)

Appendix 13

Type I test procedure for L-category vehicles equipped with a periodically regenerating system

1. Introduction

This Appendix contains specific provisions regarding the type-approval of vehicles equipped with a periodically regenerating system.

2. Scope of the type-approval for vehicles with a periodically regenerating system as regards type I tests

- 2.1. L-category vehicles falling within the scope of Regulation (EU) No 168/2013 that are equipped with periodically regenerating systems shall comply with the requirements in this Appendix.
- 2.2. Instead of carrying out the test procedures in the following point, a fixed K_i value of 1,05 may be used if the technical service sees no reason why this value could be exceeded and after approval of the approval authority.
- 2.3. During cycles where regeneration occurs, emission standards can be exceeded. If a regeneration of an anti-pollution device occurs at least once per Type I test and that has already regenerated at least once during the vehicle preparation cycle, it will be considered as a continuously regenerating system which does not require a special test procedure.

3. Test procedure

The vehicle may be equipped with a switch capable of preventing or permitting the regeneration process provided that its operation has no effect on original engine calibration. This switch shall be used for the purpose of preventing regeneration only during loading of the regeneration system and during the pre-conditioning cycles. However, it shall not be used during the measurement of emissions in the regeneration phase; rather, the emission test shall be carried out with the unchanged original equipment manufacturer's powertrain control unit / engine control unit / drive train control unit if applicable and powertrain software.

- 3.1. Measurement of carbon dioxide emission and fuel consumption between two cycles where regenerative phases occur.
 - 3.1.1. The average of carbon dioxide emission and fuel consumption between regeneration phases and during loading of the regenerative device shall be determined from the arithmetic mean of several approximately equidistant (if more than two) type I operating cycles.

As an alternative, the manufacturer may provide data to show that carbon dioxide emissions and fuel consumption remain constant (+4 percent) between regeneration phases. In this case, the carbon dioxide emissions and fuel consumption measured during the regular type I test may be used. In any other case, emissions shall be measured for at least two type I operating cycles: one immediately after regeneration (before new loading) and one as immediately as possible before a regeneration phase. All emissions measurements and calculations shall be carried out in accordance with Annex II. Average emissions for a single regenerative system shall be determined in accordance with point 3.3 and for multiple regeneration systems in accordance with point 3.4.

Status: Point in time view as at 16/12/2013.

Changes to legislation: There are currently no known outstanding effects for the Commission Delegated Regulation (EU) No 134/2014. (See end of Document for details)

- 3.1.2. The loading process and K_i determination shall be carried out on a chassis dynamometer during the type I operating cycles. These cycles may be run continuously (i.e. without the need to switch the engine off between cycles). After any number of completed cycles, the vehicle may be removed from the chassis dynamometer and the test continued at a later time.
- 3.1.3. The number of cycles (D) between two cycles in which regeneration phases occur, the number of cycles over which emissions measurements are taken (n) and each emissions measurement (M_{ij}) shall be reported according to the template of the test report referred to in Article 32(1) of Regulation (EU) No 168/2013.
- 3.2. Measurement of carbon dioxide emissions and fuel consumption during regeneration
- 3.2.1. If necessary, the vehicle may be prepared for the emissions test during a regeneration phase using the preparation cycles in Appendix 6.
- 3.2.2. The test and vehicle conditions for the type I test described in Annex II apply before the first valid emission test is carried out.
- 3.2.3. Regeneration shall not occur during the preparation of the vehicle. This may be ensured by one of the following methods:
- 3.2.3.1. a 'dummy' regenerating system or partial system may be fitted for the pre-conditioning cycles;
- 3.2.3.2. any other method agreed between the manufacturer and the approval authority.
- 3.2.4. A cold-start exhaust emission test including a regeneration process shall be carried out in accordance with the applicable type I operating cycle.
- 3.2.5. If the regeneration process requires more than one operating cycle, subsequent test cycle(s) shall be driven immediately, without switching the engine off, until complete regeneration has been achieved (each cycle shall be completed). The time necessary to set up a new test shall be as short as possible (e.g. as required to change a particulate matter filter on the analysing equipment). The engine shall be switched off during this period.
- 3.2.6. The emission values, including pollutant and carbon dioxide emission values, and fuel consumption during regeneration (M_{ri}) shall be calculated in accordance with Annex II and point 3.3. The number of operating cycles (d) measured for complete regeneration shall be recorded.
- 3.3. Calculation of the combined exhaust emissions of a single regenerative system:
Equation Ap13-1:

$$M_{ri} = \frac{\sum_{j=1}^n M_{rj}^{(i)}}{n}$$

$n \geq 2$

Equation Ap13-2:

$$M_{ri} = \frac{\sum_{j=1}^d M_{rj}^{(i)}}{d}$$

Equation Ap13-3:

$$M_{pi} = \left\{ \frac{M_{ri} \cdot D + M_{ni} \cdot d}{D + d} \right\}$$

where for each pollutant (i) considered:

Status: Point in time view as at 16/12/2013.

Changes to legislation: There are currently no known outstanding effects for the Commission Delegated Regulation (EU) No 134/2014. (See end of Document for details)

M'_{sij}	= mass emissions of pollutant (i), mass emissions of CO ₂ in g/km and fuel consumption in l/100 km over one type I operating cycle without regeneration;
M'_{rij}	= mass emissions of pollutant (i), mass emissions of CO ₂ in g/km and fuel consumption in l/100 km over one type I operating cycle during regeneration (when $n > 1$, the first type I test is run cold, and subsequent cycles are hot);
M_{si}	= mean mass emissions of pollutant (i) in mg/km or mean mass emissions of CO ₂ in g/km and fuel consumption in l/100 km over one part (i) of the operating cycle without regeneration;
M_{ri}	= mean mass emissions of pollutant (i) in mg/km or mean mass emissions of CO ₂ in g/km and fuel consumption in l/100 km over one part (i) of the operating cycle during regeneration;
M_{pi}	= mean mass emissions of pollutant (i) in mg/km or mean mass emissions of CO ₂ in g/km and fuel consumption in l/100 km;
n	= number of test points at which emissions measurements (type I operating cycles) are taken between two cycles where regenerative phases occur, ≥ 2 ;
d	= number of operating cycles required for regeneration;
D	= number of operating cycles between two cycles in which regenerative phases occur.

Figure Ap13-1

Example of measurement parameters. Parameters measured during emissions or fuel consumption test during and between cycles in which regeneration occurs (schematic example – the emissions during ‘D’ may increase or decrease)

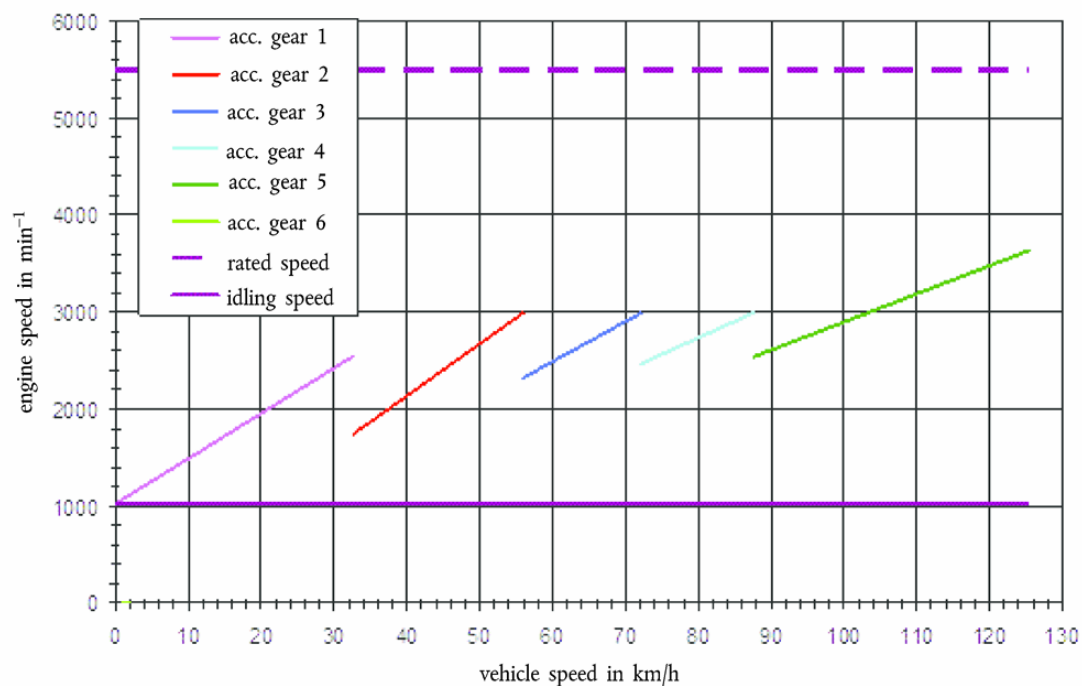

3.3.1. Calculation of the regeneration factor K for each pollutant (i), carbon dioxide emission and fuel consumption (i) considered:

Equation Ap13-4:

$$K_i = M_{pi} / M_{si}$$

M_{si} , M_{pi} and K_i results shall be recorded in the test report delivered by the technical service.

K_i may be determined following the completion of a single sequence.

3.4. Calculation of combined exhaust emissions, carbon dioxide emissions and fuel consumption of multiple periodic regenerating systems

Equation Ap13-5:

$$M_{sik} = \frac{\sum_{j=1}^{n_k} M_r^{sikj}}{n_k}$$

$$n_k \geq 2$$

Equation Ap13-6:

$$M_{rik} = \frac{\sum_{j=1}^{d_k} M_r^{rikj}}{d_j}$$

Equation Ap13-7:

$$M_{si} = \frac{\sum_{k=1}^n M_{sik} \times D_k}{\sum_{k=1}^n D_k}$$

Equation Ap13-8:

$$M_{ri} = \frac{\sum_{k=1}^n M_{rik} \times d_k}{\sum_{k=1}^n d_k}$$

Equation Ap13-9:

$$M_{pi} = \frac{M_{si} \times \sum_{k=1}^n D_k + M_{ri} \times \sum_{k=1}^n d_k}{\sum_{k=1}^n (D_k + d_k)}$$

Equation Ap13-10:

$$M_{pi} = \frac{\sum_{k=1}^n (M_{sik} \times D_k + M_{rik} \times d_k)}{\sum_{k=1}^n (D_k + d_k)}$$

Equation Ap13-11:

$$K_i = \frac{M_{pi}}{M_{si}}$$

where for each pollutant (i) considered:

- M'_{sik} = mass emissions of event k of pollutant (i) in mg/km, mass emissions of CO₂ in g/km and fuel consumption in l/100 km over one type I operating cycle without regeneration;
- M_{rik} = mass emissions of event k of pollutant (i) in mg/km, mass emissions of CO₂ in g/km and fuel consumption in l/100 km over one type I operating cycle during regeneration (if $d > 1$, the first type I test is run cold, and subsequent cycles are hot);
- M'_{sikj} = mass emissions of event k of pollutant (i) in mg/km, mass emissions of CO₂ in g/km and fuel consumption in l/100 km over one type I operating cycle without regeneration measured at point j; $1 \leq j \leq n$;
- M'_{rikj} = mass emissions of event k of pollutant (i) in mg/km, mass emissions of CO₂ in g/km and fuel consumption in l/100 km over one type I operating cycle during regeneration (when $j > 1$, the first type I test is run cold, and subsequent cycles are hot) measured at operating cycle j; $1 \leq j \leq d$;
- M_{si} = mass emission of all events k of pollutant (i) in mg/km, of CO₂ in g/km and fuel consumption in l/100 km without regeneration;
- M_{ri} = mass emission of all events k of pollutant (i) in mg/km, of CO₂ in g/km and fuel consumption in l/100 km during regeneration;

Status: Point in time view as at 16/12/2013.

Changes to legislation: There are currently no known outstanding effects for the Commission Delegated Regulation (EU) No 134/2014. (See end of Document for details)

- M_{pi} = mass emission of all events k of pollutant (i) in mg/km, of CO₂ in g/km and fuel consumption in l/100 km;
- n_k = number of test points of event k at which emissions measurements (type I operating cycles) are taken between two cycles in which regenerative phases occur;
- d_k = number of operating cycles of event k required for regeneration;
- D_k = number of operating cycles of event k between two cycles in which regenerative phases occur.

Figure Ap13-2

Parameters measured during emissions test during and between cycles in which regeneration occurs (schematic example)

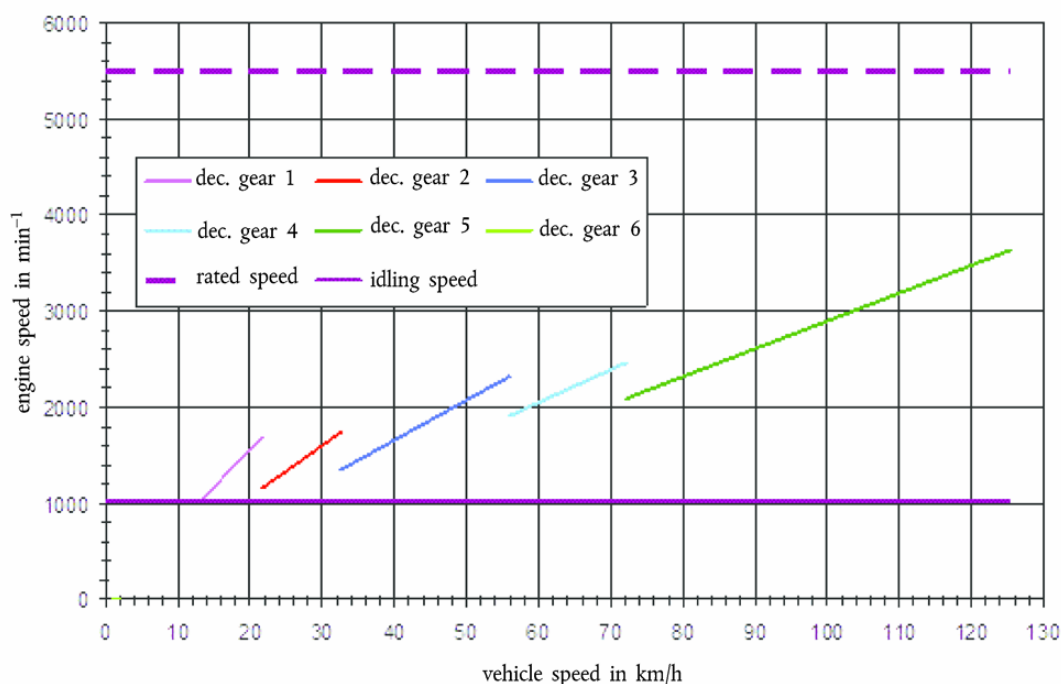
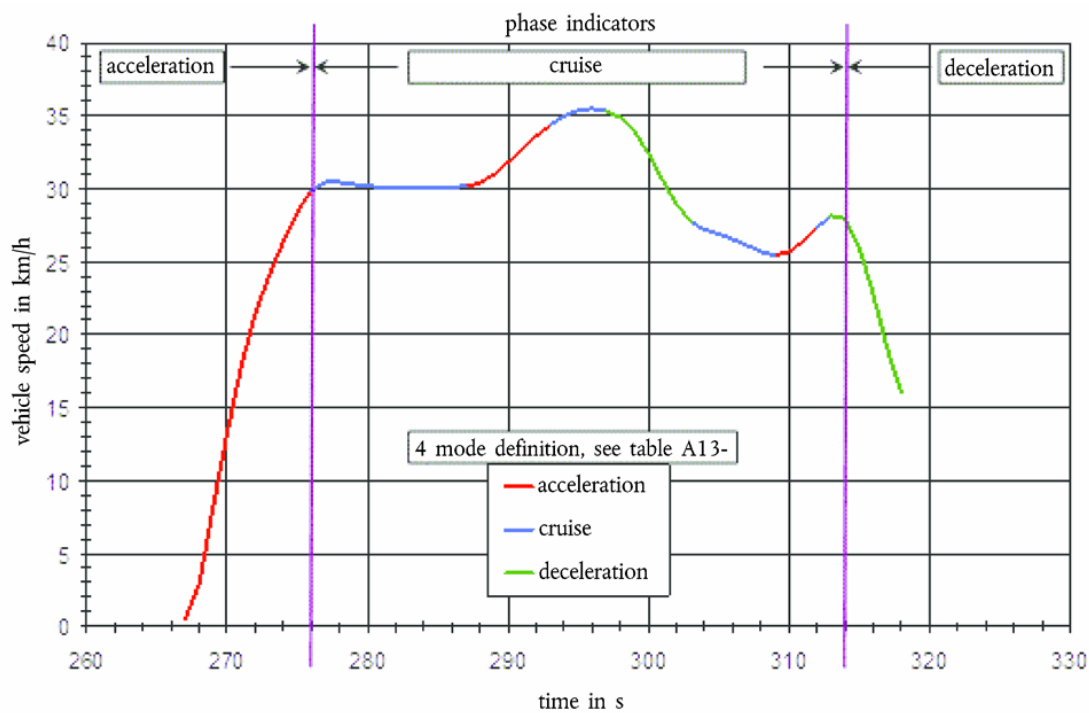

Figure Ap13-3

Status: Point in time view as at 16/12/2013.

Changes to legislation: There are currently no known outstanding effects for the Commission Delegated Regulation (EU) No 134/2014. (See end of Document for details)

Parameters measured during emissions test during and between cycles where regeneration occurs (schematic example)



For application of a simple and realistic case, the following description gives a detailed explanation of the schematic example shown in Figure Ap13-3:

1. ‘Particulate Filter’: regenerative, equidistant events, similar emissions (± 15 percent) from event to event

Equation Ap13-12:

$$D_k = D_{k+1} = D_1$$

Equation Ap13-13:

$$d_k = d_{k+1} = d_1$$

Equation Ap13-14:

$$M_{rik} - M_{sik} = M_{rik+1} - M_{sik} + 1$$

$$n_k = n$$

2. ‘DeNO_x’: the desulphurisation (SO₂ removal) event is initiated before an influence of sulphur on emissions is detectable (± 15 percent of measured emissions) and in this example, for exothermic reasons, together with the last DPF regeneration event.

Equation Ap13-15:

$$\begin{matrix} M & M_{sik} = M_{sik+1} = M_{si2} \\ '_{sik,j=1} = & \\ \text{constant} & M_{rik} = M_{rik+1} = M_{ri2} \\ \rightarrow & \end{matrix}$$

For SO₂ removal event: M_{ri2}, M_{si2}, d₂, D₂, n₂ = 1

Status: Point in time view as at 16/12/2013.

Changes to legislation: There are currently no known outstanding effects for the Commission Delegated Regulation (EU) No 134/2014. (See end of Document for details)

3. Complete system (DPF + DeNO_x):

Equation Ap13-16:

$$M_{d1} = \frac{n \times M_{d11} \times D_1 + M_{d12} \times D_2}{n \times (D_1 + d_1) + D_2 + d_2}$$

Equation Ap13-17:

$$M_{r1} = \frac{n \times M_{r11} \times d_1 + M_{r12} \times d_2}{n \times (D_1 + d_1) + D_2 + d_2}$$

Equation Ap13-18:

$$M_{pt} = \frac{M_{d1} + M_{r1}}{n \times (D_1 + d_1) + D_2 + d_2} = \frac{n \times (M_{d11} \times D_1 + M_{d11} \times d_1) + M_{d12} \times D_2 + M_{r12} \times d_2}{n \times (D_1 + d_1) + D_2 + d_2}$$

The calculation of the factor (K_i) for multiple periodic regenerating systems is possible only after a certain number of regeneration phases for each system. After performing the complete procedure (A to B, see Figure Ap13-2), the original starting conditions A should be reached again.

3.4.1. Extension of approval for a multiple periodic regeneration system

3.4.1.1. If the technical parameters or the regeneration strategy of a multiple regeneration system for all events within this combined system are changed, the complete procedure including all regenerative devices shall be performed by measurements to update the multiple K_i – factor.

3.4.1.2. If a single device of the multiple regeneration system is changed only in strategy parameters (i.e. such as ‘D’ or ‘d’ for DPF) and the manufacturer can provide the technical service with plausible technical data and information demonstrating that:

- (a) there is no detectable interaction with the other device(s) of the system; and
- (b) the important parameters (i.e. construction, working principle, volume, location, etc.) are identical,

the necessary update procedure for k_i may be simplified.

In such cases, where agreed between the manufacturer and the technical service, only a single event of sampling/storage and regeneration shall be performed and the test results (‘M_{si}’, ‘M_{ri}’), in combination with the changed parameters (‘D’ or ‘d’), may be introduced into the relevant formula(e) to update the multiple K_i - factor in mathematically by substituting the existing basic K_i - factor formula(e).

ANNEX III

Test type II requirements: tailpipe emissions at (increased) idle and free acceleration

1. Introduction

This Annex describes the procedure for type II testing, as referred to in Part A of Annex V to Regulation (EU) No 168/2013, designed to ensure the requisite measurement of emissions during roadworthiness testing. The purpose of the requirements laid down in this Annex is to demonstrate that the approved vehicle complies with the requirements laid down in Directive 2009/40/EC⁽⁸⁾.

2. Scope

- 2.1. During the environmental performance type-approval process, it shall be demonstrated to the technical service and approval authority that the L-category vehicles falling within the scope of Regulation (EU) No 168/2013 comply with the test type II requirements.
- 2.2. Vehicles equipped with a propulsion type of which a positive ignition combustion engine forms part shall be subject only to a type II emission test as set out in points 3, 4 and 5.
- 2.3. Vehicles equipped with a propulsion type of which a compression ignition combustion engine forms part shall be subject only to a type II free acceleration emission test as set out in points 3, 6 and 7. In this case point 3.8. is not applicable.

3. General conditions of type II emission testing

- 3.1. A visual inspection of any emission-control equipment shall be conducted prior to start of the type II emission test in order to check that the vehicle is complete, in a satisfactory condition and that there are no leaks in the fuel, air supply or exhaust systems. The test vehicle shall be properly maintained and used.
- 3.2. The fuel used to conduct the type II test shall be the reference fuel, specifications for which are given in Appendix 2 of Annex II in accordance with the requirements set out in Part B of Annex V of Regulation (EU) No 168/2013.
- 3.3. During the test, the environmental temperature shall be between 293,2 K and 303,2 K (20 °C and 30 °C).
- 3.4. In the case of vehicles with manually-operated or semi-automatic-shift gearboxes, the test type II test shall be carried out with the gear lever in the 'neutral' position and the clutch engaged.
- 3.5. In the case of vehicles with automatic-shift gearboxes, the idle type II test shall be carried out with the gear selector in either the 'neutral' or the 'park' position. Where an automatic clutch is also fitted, the driven axle shall be lifted up to a point at which the wheels can rotate freely.
- 3.6. The type II emission test shall be conducted immediately after the type I emission test. In any event, the engine shall be warmed up until all coolant and lubricant temperatures and lubricant pressure have reached equilibrium at operational levels.
- 3.7. The exhaust outlets shall be provided with an air-tight extension, so that the sample probe used to collect exhaust gases may be inserted at least 60 cm into the exhaust

Status: Point in time view as at 16/12/2013.

Changes to legislation: There are currently no known outstanding effects for the Commission Delegated Regulation (EU) No 134/2014. (See end of Document for details)

outlet without increasing the back pressure of more than 125 mm H₂O and without disturbing operation of the vehicle. This extension shall be so shaped as to avoid any appreciable dilution of exhaust gases in the air at the location of the sample probe. Where a vehicle is equipped with an exhaust system with multiple outlets, either these shall be joined to a common pipe or the carbon monoxide content shall be collected from each of them and an arithmetical average taken.

- 3.8. The emission test equipment and analysers to perform the type II testing shall be regularly calibrated and maintained. A flame ionisation detection or NDIR analyser may be used for measuring hydrocarbons.
- 3.9. The vehicles shall be tested with the fuel-consuming engine running.
- 3.9.1. The manufacturer shall provide a type II test ‘service mode’ that makes it possible to inspect the vehicle for roadworthiness tests on a running fuel-consuming engine, in order to determine its performance in relation to the data collected. Where this inspection requires a special procedure, this shall be detailed in the service manual (or equivalent media). That special procedure shall not require the use of special equipment other than that provided with the vehicle.
- 4. Test type II – description of test procedure to measure tailpipe emissions at (increased) idle and free acceleration**
- 4.1 Components for adjusting the idling speed
- 4.1.1. Components for adjusting the idling speed for the purposes of this Annex refer to controls for changing the idling conditions of the engine which may be easily operated by a mechanic using only the tools referred to in point 4.1.2. In particular, devices for calibrating fuel and air flows are not considered as adjustment components if their setting requires the removal of the set-stops, an operation which can normally be performed only by a professional mechanic.
- 4.1.2. The tools which may be used to adjust the idling speed are screwdrivers (ordinary or cross-headed), spanners (ring, open-end or adjustable), pliers, Allen keys and a generic scan tool.
- 4.2 Determination of measurement points and type II idle test pass/fail criteria
- 4.2.1. First, a measurement is taken at the setting in accordance with the conditions fixed by the manufacturer.
- 4.2.2. For each adjustment component with a continuous variation, a sufficient number of characteristic positions shall be determined. The test shall be carried out with the engine at normal idling speed and at ‘high idle’ speed. High idle engine speed is defined by the manufacturer but it must be higher than 2 000 min⁻¹.
- 4.2.3. The measurement of the carbon monoxide content of exhaust gases shall be carried out for all the possible positions of the adjustment components, but for components with a continuous variation only for the positions referred to in point 4.2.2.
- 4.2.4. The type II idle test shall be considered passed if one or both of the following conditions is met:
- 4.2.4.1. the values measured in accordance with point 4.2.3. shall be in compliance with the requirements set out in points 8.2.1.2. of Annex II to Directive 2009/40/EC;

Status: Point in time view as at 16/12/2013.

Changes to legislation: There are currently no known outstanding effects for the Commission Delegated Regulation (EU) No 134/2014. (See end of Document for details)

- 4.2.4.1.1. if point 8.2.1.2. (a) is selected by the manufacturer, the specific CO level given by the manufacturer shall be entered on the certificate of conformity;
- 4.2.4.1.2. If point 8.2.1.2. (b) (ii) is selected by the manufacturer, the highest CO limits (at engine idle: 0,5 %, at high idle: 0,3 %) shall apply. Footnote (6) to point 8.2.1.2. (b) (ii) shall not be applicable for vehicles in the scope of Regulation (EU) No 168/2013. The measured CO value in the Type II test procedure shall be entered on the certificate of conformity;
- 4.2.4.2. the maximum content obtained by continuously varying each of the adjustment components in turn while all other components are kept stable shall not exceed the limit value referred to in point 4.2.4.1.
- 4.2.5. The possible positions of the adjustment components shall be limited by any of the following:
 - 4.2.5.1. the larger of the following two values: the lowest idling speed which the engine can reach; the speed recommended by the manufacturer, minus 100 revolutions per minute;
 - 4.2.5.2. the smallest of the following three values:
 - (a) the highest rotation speed which the crankshaft of the engine can attain by activation of the idling speed components;
 - (b) the rotation speed recommended by the manufacturer, plus 250 revolutions per minute;
 - (c) the cut-in rotation speed of automatic clutches.
- 4.2.6. Settings incompatible with the correct running of the engine shall not be adopted as measurement settings. In particular, if the engine is equipped with several carburettors, all the carburettors shall have the same setting.
- 4.3. The following parameters shall be measured and recorded at normal idling speed and at high idle speed:
 - (a) the carbon monoxide (CO) content by volume of the exhaust gases emitted (in vol %);
 - (b) the carbon dioxide (CO₂) content by volume of the exhaust gases emitted (in vol %);
 - (c) hydrocarbons (HC) in ppm;
 - (d) the oxygen (O₂) content by volume of the exhaust gases emitted (in vol %) or lambda, as chosen by the manufacturer;
 - (e) the engine speed during the test, including any tolerances;
 - (f) the engine oil temperature at the time of the test. Alternatively, for liquid cooled engines, the coolant temperature shall be acceptable.
- 4.3.1. With respect to the parameters under point 4.3. (d) the following shall apply:
 - 4.3.1.1. the measurement shall only be conducted at high idle engine speed;
 - 4.3.1.2. vehicles in the scope of this measurement are only those equipped with a closed loop fuel system;
 - 4.3.1.3. exemptions for vehicle with:

Status: Point in time view as at 16/12/2013.

Changes to legislation: There are currently no known outstanding effects for the Commission Delegated Regulation (EU) No 134/2014. (See end of Document for details)

4.3.1.3.1. engines equipped with a mechanically-controlled (spring, vacuum) secondary air system;

4.3.1.3.2. two-stroke engines operated on a mix of fuel and lubrication oil.

5. CO concentration calculation in the type II idle test

5.1. The CO (C_{CO}) and CO₂ (C_{CO_2}) concentration shall be determined from the measuring instrument readings or recordings, by use of appropriate calibration curves.

5.2. The corrected concentration for carbon monoxide is:

Equation 2-1:

$$C_{CO_{corr}} = 15 \times \frac{C_{CO}}{C_{CO} + C_{CO_2}}$$

5.3. The C_{CO} concentration (see point 5.1.) shall be measured in accordance with the formulae in point 5.2. and does not need to be corrected if the total of the concentrations measured ($C_{CO} + C_{CO_2}$) is at least:

- (a) for petrol (E5): 15 percent;
- (b) for LPG: 13,5 percent;
- (c) for NG/biomethane: 11,5 percent.

6 Test type II – free acceleration test procedure

6.1. The combustion engine and any turbocharger or super-charger fitted shall be running at idle before the start of each free acceleration test cycle.

6.2. To initiate each free acceleration cycle, the throttle pedal shall be fully depressed quickly and continuously (in less than one second) but not violently, so as to obtain maximum delivery from the fuel pump.

6.3. During each free acceleration cycle, the engine shall reach cut-off speed or, for vehicles with automatic transmissions, the speed specified by the manufacturer or, if this data is not available, two-thirds of the cut-off speed, before the throttle is released. This could be checked, for instance, by monitoring engine speed or by allowing at least two seconds elapsing between initial throttle depression and release.

6.4. For vehicles equipped with CVT and automatic clutch, the driven wheels may be lifted from the ground.

For engines with safety limits in the engine control (e.g. max 1 500 rpm without running wheels or without gear), this maximum engine speed shall be reached.

6.5. The average concentration level of the particulate matter (in m^{-1}) in the exhaust flow (opacity) shall be measured during five free acceleration tests. Opacity means an optical measurement of the density of particulate matter in the exhaust flow of an engine, expressed in m^{-1} ;

7 Test type II – free acceleration test results and requirements

7.1. The test value measured in accordance with point 6.5 shall be in compliance with the requirements laid down in point 8.2.2.2. (b) of Annex II to Directive 2009/40/EC.

Status: Point in time view as at 16/12/2013.

Changes to legislation: There are currently no known outstanding effects for the Commission Delegated Regulation (EU) No 134/2014. (See end of Document for details)

- 7.1.1. Footnote (7) to point 8.2.2.2. (b) shall not be applicable for vehicles in the scope of Regulation (EU) No 168/2013.
- 7.1.2. The measured type II opacity test value shall be entered on the certificate of conformity. Alternatively the vehicle manufacturer may specify the appropriate opacity level and enter this limit on the certificate of conformity.
- 7.1.3. Vehicles in the scope of Regulation (EU) No 168/2013 are exempted from the requirement to enter the opacity test value on the statutory plate.

Status: Point in time view as at 16/12/2013.

Changes to legislation: There are currently no known outstanding effects for the Commission Delegated Regulation (EU) No 134/2014. (See end of Document for details)

ANNEX IV

Test type III requirements: emissions of crankcase gases

1. Introduction

This Annex describes the procedure for type III testing, as referred to in Part A of Annex V to Regulation (EU) No 168/2013.

2. General provisions

- 2.1. The manufacturer shall provide the approval authority with technical details and drawings to prove that the engine is or engines are so constructed as to prevent any fuel, lubrication oil or crankcase gases from escaping to the atmosphere from the crankcase gas ventilation system.
- 2.2. Only in the following cases shall the technical service and approval authority require the manufacturer to carry out the type III test:
 - 2.2.1. for new vehicle types with regard to environmental performance equipped with a new design of the crankcase gas ventilation system, in which case a parent vehicle, with a crankcase gas ventilation concept representative of that approved, may be selected if the manufacturer so chooses to demonstrate to the satisfaction of the technical service and approval authority that the type III test has been passed;
 - 2.2.2. if there is any doubt that any fuel, lubrication oil or crankcase gases might escape to the atmosphere from the crankcase gas ventilation system, the technical service and the approval authority may require the manufacturer to conduct the type III test in accordance with point 4.1 or 4.2 (as chosen by the manufacturer).
- 2.3. In all other cases, the type III test shall be waived.
- 2.4. L-category vehicles equipped with a two-stroke engine containing a scavenging port between the crank case and the cylinder(s) may be exempted from the type III test requirements at the request of the manufacturer.
- 2.5. The manufacturer shall attach a copy of the test report on the parent vehicle with the positive result from the type III test to the information folder provided for in Article 27 of Regulation (EU) No 168/2013.

3. Test conditions

- 3.1. The type III test shall be carried out on a test vehicle which has been subjected to the type I testing in Annex II and the type II testing in Annex III.
- 3.2. The vehicle tested shall have a leak-proof engine or leak-proof engines of a type other than those so designed that even a slight leak may cause unacceptable operating faults. The test vehicle shall be properly maintained and used.

4. Test methods

- 4.1. The type III test shall be conducted according to the following test procedure:
 - 4.1.1. Idling shall be regulated in conformity with the manufacturer's recommendations.
 - 4.1.2. Measurements shall be taken in the following sets of conditions of engine operation:

Status: Point in time view as at 16/12/2013.

Changes to legislation: There are currently no known outstanding effects for the Commission Delegated Regulation (EU) No 134/2014. (See end of Document for details)

TABLE 3-1

Idle operation or steady state vehicle test speeds and power absorbed by the chassis dynamometer during the type III test

Condition number	Vehicle speed (km/h)
1	Idling
2	Highest of:
3	(a) 50 ±2 (in 3rd gear or 'drive') or (b) if (a) not achievable, 50 % of max. design vehicle speed.
Condition number	Power absorbed by the brake
1	Nil
2	That corresponding to the setting for type I test at 50 km/h or if not achievable type I test at 50 % of max. design vehicle speed.
3	As for condition 2, multiplied by a factor of 1,7

- 4.1.3. For all operation conditions listed in point 4.1.2., the reliable functioning of the crankcase ventilation system shall be checked.
- 4.1.4. Method of verification of the crankcase ventilation system
- 4.1.4.1. The engine's apertures shall be left as found.
- 4.1.4.2. The pressure in the crankcase shall be measured at an appropriate location. It may be measured at the dip-stick hole with an inclined-tube manometer.
- 4.1.4.3. The vehicle shall be deemed satisfactory if, in every condition of measurement defined in point 4.1.2., the pressure measured in the crankcase does not exceed the atmospheric pressure prevailing at the time of measurement.
- 4.1.5. For the test method described in points 4.1.4.1. to 4.1.4.3., the pressure in the intake manifold shall be measured to within ±1 kPa.
- 4.1.6. The vehicle speed as indicated at the dynamometer shall be measured to within ± 2 km/h.
- 4.1.7. The pressures measured in the crankcase and the ambient pressure shall be measured to within ± 0,1 kPa and shall be sampled with a frequency ≥ 1 Hz within a time period of ≥ 60 s when the conditions in point 4.1.2. are continuously operated and stabilised.
- 4.2. If, in one or more of the conditions of measurement in point 4.1.2., the highest pressure value measured in the crankcase within the time period in point 4.1.7. exceeds the atmospheric pressure, an additional test as defined in point 4.2.1. or 4.2.3. (as chosen by the manufacturer) shall be performed to the satisfaction of the approval authority.
- 4.2.1. Additional type III test method (No 1)
- 4.2.1.1. The engine's apertures shall be left as found.

Status: Point in time view as at 16/12/2013.

Changes to legislation: There are currently no known outstanding effects for the Commission Delegated Regulation (EU) No 134/2014. (See end of Document for details)

- 4.2.1.2. A flexible bag impervious to crankcase gases and having a capacity of approximately five litres shall be connected to the dipstick hole. The bag shall be empty before each measurement.
- 4.2.1.3. The bag shall be closed before each measurement. It shall be opened to the crankcase for five minutes for each condition of measurement prescribed in point 4.1.2.
- 4.2.1.4. The vehicle shall be deemed satisfactory if, in every condition of measurement defined in points 4.1.2. and 4.2.1.3., no visible inflation of the bag occurs.
- 4.2.2. If the structural layout of the engine is such that the test cannot be performed by the methods described in point 4.2.1., the measurements shall be effected by that method modified as follows:
- 4.2.2.1. Before the test, all apertures other than that required for the recovery of the gases shall be closed;
- 4.2.2.2. The bag shall be placed on a suitable take-off which does not introduce any additional loss of pressure and is installed on the recycling circuit of the device directly at the engine-connection aperture.
- 4.2.2.3. *Figure 3-1*

Various test set-ups for type III test method No 1

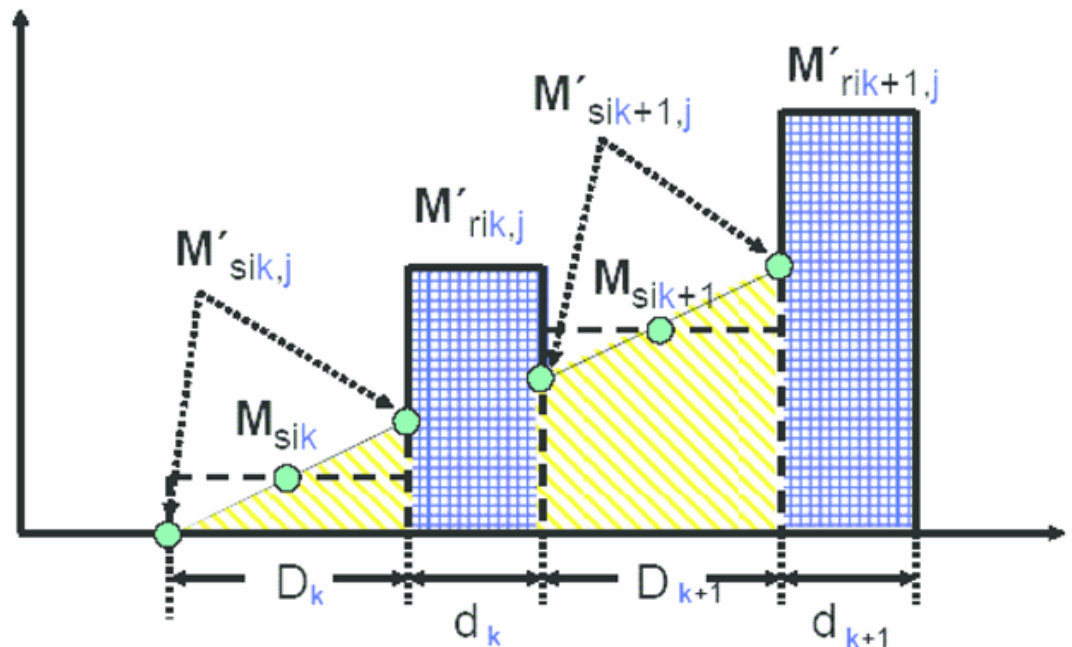

- 4.2.3. Alternative additional type III test method (No 2)
- 4.2.3.1. The manufacturer shall prove to the approval authority that the crankcase ventilation system of the engine is leak-tight by performing a leak check with compressed air inducing an overpressure in the crankcase ventilation system.

Status: Point in time view as at 16/12/2013.

Changes to legislation: There are currently no known outstanding effects for the Commission Delegated Regulation (EU) No 134/2014. (See end of Document for details)

- 4.2.3.2. The engine of the vehicle may be installed on a test rig and the intake and exhaust manifolds may be removed and replaced with plugs that hermetically seal the air intake and exhaust evacuation openings of the engine. Alternatively, the intake and exhaust systems may be plugged on a representative test vehicle on locations chosen by the manufacturer and to the satisfaction of the technical service and approval authority.
- 4.2.3.3. The crankshaft may be rotated to optimise the position of the pistons, minimising pressure loss to the combustion chamber(s).
- 4.2.3.4. The pressure in the crankcase system shall be measured at an appropriate location other than the opening to the crankcase system used to pressurise the crankcase. When present, the oil fill cap, drain plug, level check port and dipstick cap may be modified to facilitate the pressurisation and pressure measurement; however, all seals between the screw-thread, gaskets, O-rings and other (pressure) seals of the engine shall remain intact and representative of the engine type. Ambient temperature and pressure shall remain constant throughout the test.
- 4.2.3.5. The crankcase system shall be pressurised with compressed air to the maximum recorded peak pressure as monitored during the three test conditions specified in point 4.1.2. and at least to a pressure of 5 kPa over ambient pressure or to a higher pressure at the choice of the manufacturer. The minimum pressure of 5 kPa shall be allowed only if it can be demonstrated by means of traceable calibration that test equipment has accurate resolution for testing at that pressure. A higher test pressure shall be used otherwise, according to the equipment's calibrated resolution.
- 4.2.3.5. The compressed air source inducing the overpressure shall be closed and the pressure in the crankcase shall be monitored for 300 seconds. The test pass condition shall be: crankcase pressure $\geq 0,95$ times the initial overpressure for 300 seconds after closure of the compressed air source.

Status: Point in time view as at 16/12/2013.

Changes to legislation: There are currently no known outstanding effects for the Commission Delegated Regulation (EU) No 134/2014. (See end of Document for details)

ANNEX V

Test type IV requirements: evaporative emissions

Appendix Number	Appendix title	Page
1	Fuel storage permeability test procedure	168
2	Fuel storage and delivery system permeation test procedure	169
3	Sealed Housing for Evaporation Determination (SHED) test procedure	174
3.1.	Preconditioning requirements for a hybrid application before start of the SHED test	181
3.2.	Ageing test procedure for evaporative emission control devices	183
4	Calibration of equipment for evaporative emission testing	185

1. Introduction

- 1.1. This Annex describes the procedure for type IV testing, as referred to in Part A of Annex V to Regulation (EU) No 168/2013.
- 1.2. Appendix 1 describes the procedure for testing the permeability of non-metallic fuel tank material and shall also be used as preconditioning test cycle for fuel storage testing referred to in Number C8 of Annex II to Regulation (EU) No 168/2013.
- 1.3. Appendices 2 and 3 describe methods for the determination of the loss of hydrocarbons by evaporation from the fuel systems of vehicles equipped with a propulsion type that uses volatile, liquid fuel. Appendix 4 sets out the calibration procedure for evaporative emission test equipment.

2. General requirements

- 2.1. The vehicle manufacturer shall prove to the technical service and to the satisfaction of the approval authority that the fuel tank and fuelling system are leak-tight.
- 2.2. The fuelling system tightness shall comply with the requirements referred to in Annex II (C8) to Regulation (EU) No 168/2013.
- 2.3. All L-vehicle (sub-)categories equipped with a non-metallic fuel storage shall be tested according to the permeability test procedure laid down in Appendix 1. At the request of the manufacturer, the fuel permeation test set out in Appendix 2 or the SHED test set out in Appendix 3 may replace the evaporative part of the permeability test set out in Appendix 1.

Status: Point in time view as at 16/12/2013.

Changes to legislation: There are currently no known outstanding effects for the Commission Delegated Regulation (EU) No 134/2014. (See end of Document for details)

- 2.4. L-vehicle (sub-)categories L3e, L4e, L5e-A, L6e-A and L7e-A shall be tested according to the SHED test procedure laid down in Appendix 3.
- 2.5. The fuel permeation test procedure set out in Appendix 2 shall be subject to the general assessment in the environmental effect study referred to in point 5(b) of Article 23 of Regulation (EU) No 168/2013. This study shall confirm whether L-vehicle (sub-)categories L1e-A, L1e-B, L2e, L5e-B, L6e-B, L7e-B and L7e-C shall be tested either according to the permeation test procedure set out in Appendix 2 or the SHED test procedure set out in Appendix 3.
- 2.6. If an L1e-A, L1e-B, L2e, L5e-B, L6e-B, L7e-B and L7e-C vehicle is to be subject to a SHED test procedure set out in Part C of Annex VI to Regulation (EU) No 168/2013 and in Appendix 3, it shall be exempted from the fuel permeation test procedure set out in Appendix 2 and vice versa.

Status: Point in time view as at 16/12/2013.

Changes to legislation: There are currently no known outstanding effects for the Commission Delegated Regulation (EU) No 134/2014. (See end of Document for details)

Appendix 1

Fuel storage permeability test procedure

1. Scope

- 1.1. This requirement shall apply to all L-category vehicles equipped with a non-metallic fuel tank to store liquid, volatile fuel, as applicable for vehicles equipped with a positive ignition combustion engine.
- 1.2. Vehicles complying with the requirements set out in Appendix 2 or 3 or vehicles equipped with a compression ignition engine using low volatile fuel shall comply with the requirements of this Appendix only as preconditioning procedure for fuel storage testing referred to in Number C8 of Annex II to Regulation (EU) No 168/2013. The fuel tanks on those vehicles are exempted from the evaporative requirements set out in points 2.1.5, 2.1.6, 2.3. and 2.4.

2. Fuel tank permeability test

2.1. Test method

2.1.1. Test temperature

The fuel tank shall be tested at a temperature of $313,2 \pm 2$ K (40 ± 2 °C).

2.1.2. Test fuel

The test fuel to be used shall be the reference fuel set out in Appendix 2 of Annex II. If this test procedure is used only as preconditioning for subsequent fuel storage testing referred to in Number C8 of Annex II to Regulation (EU) No 168/2013, a commercial premium-grade fuel may be used at the choice of the manufacturer and to the satisfaction of the approval authority.

- 2.1.3. The tank is filled with the test fuel up to 50 % of its total rated capacity and allowed to rest in the ambient air at a temperature of $313,2 \pm 2$ K until there is a constant weight loss. That period shall be at least four weeks (pre-storage period). The tank is emptied and then refilled with test fuel to 50 % of its rated capacity.

- 2.1.4. The tank is stored under the stabilising conditions at a temperature of $313,2 \pm 2$ K until its contents are at the test temperature. The tank is then sealed. The pressure rise in the tank during the test may be compensated.

- 2.1.5. The weight loss due to diffusion shall be measured during the eight-week test. During that period, a maximum quantity of 20 000 mg may escape from the fuel tank, on average, every 24 hours.

- 2.1.6. If the diffusion losses are greater, the fuel loss shall also be determined at a test temperature of $296,2 \pm 2$ K (23 ± 2 °C), all other conditions being maintained (pre-storage at $313,2 \pm 2$ K). The loss determined under those conditions shall not exceed 10 000 mg per 24 hours.

- 2.2. All fuel tanks that will undergo this test procedure as preconditioning for testing referred to in Number C8 of Annex II to Regulation (EU) No 168/2013 shall be duly identified.

- 2.3. The permeability evaporation test results shall not be averaged between the different tested fuel tanks, but the worst-case diffusion loss rate observed of any one of those

Status: Point in time view as at 16/12/2013.

Changes to legislation: There are currently no known outstanding effects for the Commission Delegated Regulation (EU) No 134/2014. (See end of Document for details)

fuel tanks shall be taken and compared against the maximum permitted loss rate set out in point 2.1.5 and, if applicable, in point 2.1.6.

2.4. Fuel tank permeability test conducted with internal pressure compensation

If the fuel tank permeability test is conducted with internal pressure compensation, which shall be noted in the test report, the fuel loss resulting from the pressure compensation shall be taken into account when the diffusion loss is calculated.

Status: Point in time view as at 16/12/2013.

Changes to legislation: There are currently no known outstanding effects for the Commission Delegated Regulation (EU) No 134/2014. (See end of Document for details)

Appendix 2

Fuel storage and delivery system permeation test procedure

1 Scope and test limits

- 1.1. As of the date of first application laid down in Annex IV to Regulation (EU) No 168/2013, fuel system permeation shall be tested in accordance with the test procedure laid down in point 2. This base requirement shall apply to all L-category vehicles equipped with a fuel tank to store liquid, high volatile fuel, as applicable for a vehicle equipped with a positive ignition combustion engine, in accordance with Part B of Annex V to Regulation (EU) No 168/2013 and pending the results of the environmental effect study laid down in Article 23 of Regulation (EU) No 168/2013.
- 1.2. For the purposes of the requirements of this Appendix, the minimum fuel system components falling within the scope of this Appendix consist of a fuel storage tank and fuel line sub-assembly. Other components that form part of the fuel delivery system, fuel metering and control system are not subject to the requirements of this Appendix.

2. Description of the fuel tank permeation test

- 2.1 Measure permeation emissions by weighing a sealed fuel tank before and after a temperature-controlled soak according to the following flow charts

Figure Ap2-1

Fuel tank permeation full and short tests

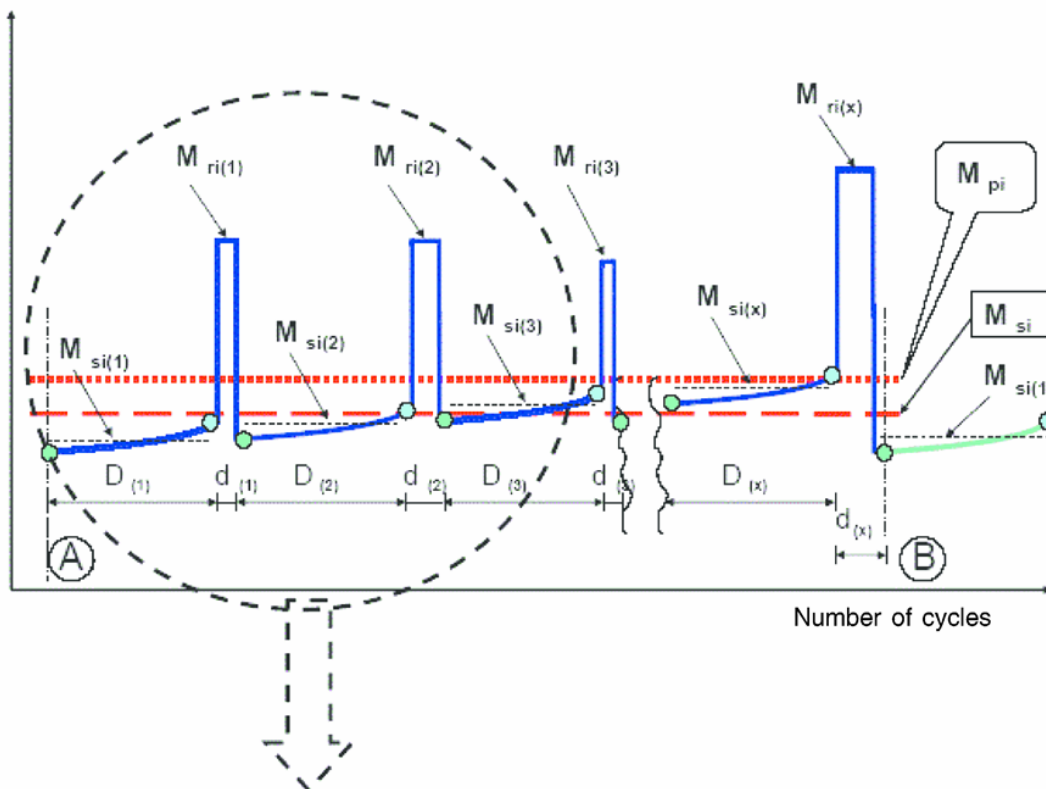

2.2. Metallic tanks are exempted from durability testing.

3. **Preconditioning fuel soak for the fuel tank permeation test**

To precondition the fuel tank in the fuel tank permeation test, the following five steps shall be followed:

- 3.1. The tank shall be filled with reference fuel specified in Appendix 2 to Annex II, and sealed. The filled tank shall be soaked at an ambient temperature of $301,2 \pm 5$ K (28 ± 5 °C) for 20 weeks or at $316,2 \pm 5$ K (43 ± 5 °C) for ten weeks. Alternatively, a shorter period of time at a higher -temperature may be used as soak time if the manufacturer can prove to the approval authority that the hydrocarbon permeation rate has stabilised.
- 3.2. The fuel tank's internal surface area shall be determined in square metres accurate to at least three significant figures. The manufacturer may use less accurate estimates of the surface area if it is ensured that the surface area will not be overestimated.
- 3.3. The fuel tank shall be filled with the reference fuel to its nominal capacity.
- 3.4. The tank and fuel shall equilibrate to $301,2 \pm 5$ K (28 ± 5 °C) or $316,2 \pm 5$ K (43 ± 5 °C) in the case of the alternative short test.
- 3.5. The fuel tank shall be sealed using fuel caps and other fittings (excluding petcocks) that can be used to seal openings in a production fuel tank. In cases where openings are not normally sealed on the fuel tank (such as hose-connection fittings and vents in fuel caps), these openings may be sealed using non-permeable fittings such as metal or fluoropolymer plugs.

4. **Fuel tank permeation test procedure**

To run the test, the following steps shall be taken for a tank preconditioned as specified in point 3.

- 4.1. Weigh the sealed fuel tank and record the weight in mg. This measurement shall be taken within eight hours of filling of the tank with test fuel.
- 4.2. The tank shall be placed in a ventilated, temperature-controlled room or enclosure.
- 4.3. The test room or enclosure shall be closed and sealed and the test time shall be recorded.
- 4.4. The test room or enclosure temperature shall be continuously maintained at $301,2 \pm 2$ K (28 ± 5 °C) for 14 days. This temperature shall be continuously monitored and recorded.

5. **Fuel tank permeation test result calculation**

- 5.1. At the end of the soak period, the weight in mg of the sealed fuel tank shall be recorded. Unless the same fuel is used in the preconditioning fuel soak and the permeation test run, weight measurements shall be recorded on five separate days per week of testing. The test is void if a linear plot of tank weight vs. test days for the full soak period for permeation testing yields a linear regression correlation coefficient $r^2 < 0,8$.
- 5.2. The weight of the filled fuel tank at the end of the test shall be subtracted from the weight of the filled fuel tank at the beginning of the test.
- 5.3. The difference in mass shall be divided by the internal surface area of the fuel tank.

Status: Point in time view as at 16/12/2013.

Changes to legislation: There are currently no known outstanding effects for the Commission Delegated Regulation (EU) No 134/2014. (See end of Document for details)

- 5.4. The result of the calculation under point 5.3., expressed in mg/m^2 , shall be divided by the number of test days to calculate the $\text{mg}/\text{m}^2/\text{day}$ emission rate and rounded to the same number of decimal places as the emission standard laid down in Part C2 of Annex VI to Regulation (EU) No 168/2013.
- 5.5. In cases where permeation rates during a soak period of 14 days are such that the manufacturer considers that period not long enough to be able to measure significant weight changes, the period may be extended by a maximum of 14 additional days. In this case, the test steps in points 4.5 to 4.8 shall be repeated to determine the weight change for the full 28 days.
- 5.6. Determination of the deterioration factor when applying the full permeation test procedure

The deterioration factor (DF) shall be determined from any of the following at the choice of the manufacturer:

- 5.6.1. the ratio between the final permeation and baseline test runs;
- 5.6.2. the fixed DF for total hydrocarbons laid down in Part B of Annex VII to Regulation (EU) No 168/2013.
- 5.7. Determination of the final tank permeation test results
- 5.7.1. Full test procedure

To determine the permeation test result, the deterioration factor determined in point 5.6. shall be multiplied by the measured permeation test result determined in point 5.4. The product of multiplication shall be no greater than the applicable permeation test limit set out in Part C2 of Annex VI to Regulation (EU) No 168/2013.

- 5.7.2. Accelerated (short) test procedure

The measured permeation test result determined in point 5.4 shall be no greater than the applicable permeation test limit set out in Part C2 of Annex VI to Regulation (EU) No 168/2013.

6. **Fuel tank durability testing**

- 6.1. A separate durability demonstration for each substantially different combination of treatment approaches and non-metallic tank materials shall be performed by taking the following steps:

- 6.1.1. Pressure cycling

A pressure test shall be conducted by sealing the tank and cycling it between 115,1 kPa absolute pressure(+ 2,0 psig) and 97,9 kPa absolute pressure (– 0,5 psig) and back to 115,1 kPa absolute pressure(+ 2,0 psig) for 10 000 cycles at a rate of 60 seconds per cycle.

- 6.1.2. UV exposure

A sunlight exposure test shall be conducted by exposing the fuel tank to an ultraviolet light of at least $24 \text{ W}/\text{m}^2$ ($0,40 \text{ W}\cdot\text{hr}/\text{m}^2/\text{min}$) on the tank surface for at least 450 hours. Alternatively, the non-metallic fuel tank may be exposed to direct natural sunlight for an equivalent period of time, as long as it is ensured that it is exposed to at least 450 daylight hours.

- 6.1.3. Slosh testing

A slosh test shall be conducted by filling the non-metallic fuel tank to 40 percent of its capacity with the reference fuel set out in Appendix 2 to Annex II or with a commercial premium-grade fuel at the choice of the manufacturer and to the satisfaction of the approval authority. The fuel tank assembly shall be rocked at a rate of 15 cycles per minute until one million total cycles are reached. An angle deviation of + 15° to – 15° from level shall be used and the slosh test shall be conducted at an ambient temperature of $301,2 \pm 5$ K (28 ± 5 °C).

6.2. Final fuel tank durability test results

Following the durability testing, the fuel tank shall be soaked according to the requirements of point 3 to ensure that the permeation rate is stable. The period of slosh testing and the period of ultraviolet testing may be considered to be part of this soak, provided that the soak begins immediately after the slosh testing. To determine the final permeation rate, the fuel tank shall be drained and refilled with fresh test fuel as set out in Appendix 2 to Annex II. The permeation test run laid down in point 4 shall be repeated immediately after this soak period. The same test fuel requirement shall be used for this permeation test run as for the permeation test run conducted prior to the durability testing. The final test results shall be calculated in accordance with point 5.

6.3. The manufacturer may request that any of the durability tests be excluded if it can be clearly demonstrated to the approval authorities that this does not affect the emissions from the fuel tank.

6.4. The length of ‘soak’ during durability testing may be included in the fuel soak period provided that fuel remains in the tank. Soak periods may be shortened to ten weeks if performed at $316,2 \pm 5$ K (43 ± 5 °C).

7. Fuel line assembly test requirements

7.1. Fuel line assembly permeation physical testing procedure

The manufacturer shall conduct a fuel line assembly test, including the fuel hose clamps and the material to which the fuel lines are connected on both sides, by performing a physical test in accordance with any of the following test procedures:

- (a) in accordance with the requirements of points 6.2 to 6.4. The piping material to which the fuel lines are connected at both sides of the fuel line shall be plugged with impermeable material. The words ‘fuel tank’ in points 6.2 to 6.4 shall be replaced with ‘fuel-line assembly’. The fuel hose clamps shall be tightened with the torque specified for series production;
- (b) the manufacturer may use a proprietary test procedure if it can be demonstrated to the approval authority that this test is just as severe as test method (a).

7.2. Fuel line assembly permeation test limits in the case of physical testing

The test limits for fuel tubing in Part C2 of Annex VI to Regulation (EU) No 168/2013 shall be met when conducting the test procedures laid down in point 7.1.

7.3. Physical testing of fuel-line assembly permeation is not required if:

- (a) the fuel lines meet the R11–A or R12 permeation specifications in SAE J30, or
- (b) non-metallic fuel lines meet the Category 1 specifications for permeation in SAE J2260, and
- (c) the manufacturer can demonstrate to the approval authority that the connections between the fuel tank and other fuel system components are leak-tight thanks to robust design.

Status: Point in time view as at 16/12/2013.

Changes to legislation: There are currently no known outstanding effects for the Commission Delegated Regulation (EU) No 134/2014. (See end of Document for details)

If the fuel hoses fitted on the vehicle meet all three specifications, the fuel tubing test limit requirements in Part C2 of Annex VI to Regulation (EU) No 168/2013 shall be considered as fulfilled.

Appendix 3

Sealed Housing for Evaporation Determination (SHED) test procedure

1. Scope

- 1.1. As of the application date laid down in Annex IV to Regulation (EU) No 168/2013, the evaporative emissions of sub-category L3e, L4e (only the base, original L3e vehicle of the motorcycle with side-car), L5e-A, L6e-A and L7e-A vehicles shall be tested in the environmental performance type-approval procedure according to the following SHED test procedure.

2. Description of SHED test

The evaporative emission SHED test (Figure Ap3-1) consists of a conditioning phase and a test phase, as follows:

- (a) conditioning phase:
- driving cycle;
 - vehicle soak;
- (b) test phase:
- diurnal (breathing loss) test;
 - driving cycle;
 - hot soak loss test.

Mass emissions of hydrocarbons from the tank breathing loss and the hot soak loss phases are added together to provide an overall result for the test.

Figure Ap3-1

Status: Point in time view as at 16/12/2013.

Changes to legislation: There are currently no known outstanding effects for the Commission Delegated Regulation (EU) No 134/2014. (See end of Document for details)

Flow chart – evaporative emission SHED test

Emission [g/km]

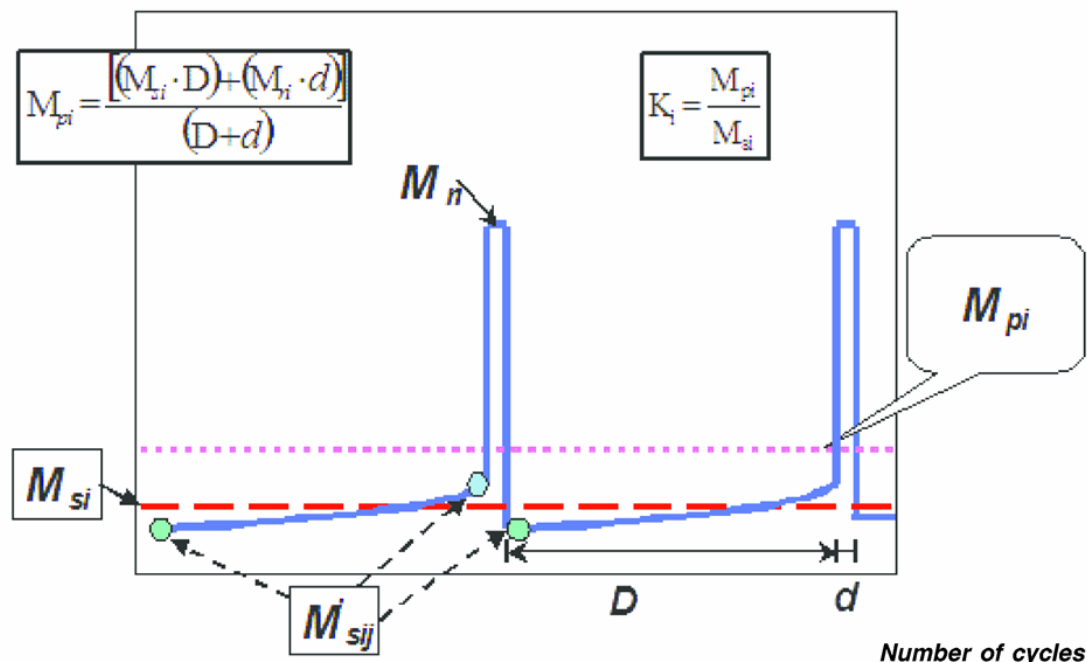

3. Test vehicles and test fuel requirement

3.1. Test vehicles

The SHED test shall be conducted at the choice of the manufacturer with one or more degreened test vehicles equipped with:

- 3.1.1. degreened emission control devices; a fixed deterioration factor of 0,3 g/test shall be added to the SHED test result;
- 3.1.2. aged evaporative emission control devices; the ageing test procedure set-out in sub-appendix 3.2. shall apply.

3.2. Test vehicles

The degreened test vehicle, which shall be representative of the vehicle type with regard to environmental performance to be approved, shall be in good mechanical condition and, before the evaporative test, have been run in and driven at least 1 000 km after first start on the production line. The evaporative emission-control system shall be connected and functioning correctly over this period and the carbon canister and evaporative emission control valve subjected to normal use, undergoing neither abnormal purging nor abnormal loading.

3.3. Test fuel

The appropriate test fuel, as defined in Appendix 2 to Annex II, shall be used.

4. Chassis dynamometer and evaporative emissions enclosure

- 4.1. The chassis dynamometer shall meet the requirements of Appendix 3 of Annex II.
- 4.2. Evaporative emission measurement enclosure (SHED)

Status: Point in time view as at 16/12/2013.

Changes to legislation: There are currently no known outstanding effects for the Commission Delegated Regulation (EU) No 134/2014. (See end of Document for details)

The evaporative emission measurement enclosure shall be a gas-tight rectangular measuring chamber able to contain the vehicle under test. The vehicle shall be accessible from all sides when inside and the enclosure when sealed shall be gas-tight. The inner surface of the enclosure shall be impermeable to hydrocarbons. At least one of the surfaces shall incorporate a flexible impermeable material or other device to allow the equilibration of pressure changes resulting from small changes in temperature. Wall design shall be such as to promote good dissipation of heat.

4.3. Analytical systems

4.3.1. Hydrocarbon analyser

4.3.1.1. The atmosphere within the chamber is monitored using a hydrocarbon detector of the flame ionisation detector (FID) type. Sample gas shall be drawn from the midpoint of one side wall or the roof of the chamber and any bypass flow shall be returned to the enclosure, preferably to a point immediately downstream of the mixing fan.

4.3.1.2. The hydrocarbon analyser shall have a response time to 90 % of final reading of less than 1,5 seconds. Its stability shall be better than 2 % of full scale at zero and at 80 ± 20 % of full scale over a 15-minute period for all operational ranges.

4.3.1.3. The repeatability of the analyser expressed as one standard deviation shall be better than 1 % of full scale deflection at zero and at 80 ± 20 % of full scale on all ranges used.

4.3.1.4. The operational ranges of the analyser shall be chosen to give best resolution over the measurement, calibration and leak-checking procedures.

4.3.2. Hydrocarbon analyser data recording system

4.3.2.1. The hydrocarbon analyser shall be fitted with a device to record electrical signal output either by strip chart recorder or other data-processing system at a frequency of at least once per minute. The recording system shall have operating characteristics at least equivalent to the signal being recorded and shall provide a permanent record of results. The record shall show a positive indication of the beginning and end of the fuel tank heating and hot soak periods together with the time elapsed between start and completion of each test.

4.4. Fuel tank heating

4.4.1. The fuel tank heating system shall consist of two separate heat sources with two temperature controllers. Typically, the heat sources will be electric heating strips, but other sources may be used at the request of the manufacturer. Temperature controllers may be manual, such as variable transformers, or automated. Since vapour and fuel temperature are to be controlled separately, an automatic controller is recommended for the fuel. The heating system shall not cause hot-spots on the wetted surface of the tank which would cause local overheating of the fuel. Heating strips for the fuel should be located as low as practicable on the fuel tank and shall cover at least 10 % of the wetted surface. The centre line of the heating strips shall be below 30 % of the fuel depth as measured from the bottom of the fuel tank, and approximately parallel to the fuel level in the tank. The centre line of the vapour heating strips, if used, shall be located at the approximate height of the centre of the vapour volume. The temperature controllers shall be capable of controlling the fuel and vapour temperatures to the heating function described in 5.3.1.6.

4.4.2. With temperature sensors positioned as in point 4.5.2., the fuel heating device shall make it possible to evenly heat the fuel and fuel vapour in the tank in accordance

Status: Point in time view as at 16/12/2013.

Changes to legislation: There are currently no known outstanding effects for the Commission Delegated Regulation (EU) No 134/2014. (See end of Document for details)

with the heating function described in 5.3.1.6. The heating system shall be capable of controlling the fuel and vapour temperatures to $\pm 1,7$ K of the required temperature during the tank heating process.

- 4.4.3. Notwithstanding the requirements of point 4.4.2., if a manufacturer is unable to meet the heating requirement specified, due to use of thick-walled plastic fuel tanks for example, then the closest possible alternative heat slope shall be used. Prior to the commencement of any test, the manufacturer shall submit engineering data to the technical service to support the use of an alternative heat slope.
- 4.5. Temperature recording
- 4.5.1. The temperature in the chamber is recorded at two points by temperature sensors which are connected so as to show a mean value. The measuring points are extended approximately 0,1 m into the enclosure from the vertical centre line of each side wall at a height of $0,9 \pm 0,2$ m.
- 4.5.2. The temperatures of the fuel and fuel vapour shall be recorded by means of sensors positioned in the fuel tank as described in point 5.1.1. When sensors cannot be positioned as specified in point 5.1.1, e.g. where a fuel tank with two ostensibly separate chambers is used, sensors shall be located at the approximate mid-volume of each fuel- or vapour-containing chamber. In this case, the average of these temperature readings shall constitute the fuel and vapour temperatures.
- 4.5.3. Throughout the evaporative emission measurements, temperatures shall be recorded or entered into a data processing system at a frequency of at least once per minute.
- 4.5.4. The accuracy of the temperature recording system shall be within $\pm 1,7$ K and capable of resolving temperatures to 0,5 K.
- 4.5.5. The recording or data processing system shall be capable of resolving time to ± 15 seconds.
- 4.6. Fans
- 4.6.1. It shall be possible to reduce the hydrocarbon concentration in the chamber to the ambient hydrocarbon level by using one or more fans or blowers with the SHED door(s) open.
- 4.6.2. The chamber shall have one or more fans or blowers of likely capacity 0,1 to 0,5 m³/s with which to thoroughly mix the atmosphere in the enclosure. It shall be possible to attain an even temperature and hydrocarbon concentration in the chamber during measurements. The vehicle in the enclosure shall not be subjected to a direct stream of air from the fans or blowers.
- 4.7. Gases
- 4.7.1. The following pure gases shall be available for calibration and operation:
- (a) purified synthetic air (purity: < 1 ppm C¹ equivalent < 1 ppm CO, < 400 ppm CO₂, 0,1 ppm NO); oxygen content between 18 and 21 % by volume;
- (b) hydrocarbon analyser fuel gas (40 ± 2 % hydrogen, and balance helium with less than 1 ppm C¹ equivalent hydrocarbon, less than 400 ppm CO₂);
- (c) propane (C₃H₈), 99,5 % minimum purity.

Status: Point in time view as at 16/12/2013.

Changes to legislation: There are currently no known outstanding effects for the Commission Delegated Regulation (EU) No 134/2014. (See end of Document for details)

4.7.2. Calibration and span gases shall be available containing mixtures of propane (C₃H₈) and purified synthetic air. The true concentrations of a calibration gas shall be within $\pm 2\%$ of the stated figures. The accuracy of the diluted gases obtained when using a gas divider shall be to within $\pm 2\%$ of the true value. The concentrations specified in Appendix 1 may also be obtained by the use of a gas divider using synthetic air as the diluting gas.

4.8. Additional equipment

4.8.1. The relative humidity in the test area shall be measurable to within $\pm 5\%$.

4.8.2. The pressure within the test area shall be measurable to within $\pm 0,1$ kPa.

4.9. Alternative equipment

4.9.1. At the request of the manufacturer and with the agreement of the approval authority, the technical service may authorise the use of alternative equipment provided that it can be demonstrated that it gives equivalent results.

5. Test procedure

5.1. Test preparation

5.1.1. The vehicle is mechanically prepared before the test as follows:

- (a) the exhaust system of the vehicle shall not exhibit any leaks;
- (b) the vehicle may be steam-cleaned before the test;
- (c) the fuel tank of the vehicle shall be equipped with temperature sensors so that the temperature of the fuel and fuel vapour in the fuel tank can be measured when it is filled to $50\% \pm 2\%$ of its rated capacity;
- (d) additional fittings, adaptors or devices may optionally be fitted to allow a complete draining of the fuel tank. Alternatively, the fuel tank may be evacuated by means of a pump or siphon that prevents fuel spillage.

5.2. Conditioning phase

5.2.1. The vehicle shall be taken into the test area where the ambient temperature is between 293,2 K and 303,2 K (20 °C and 30 °C).

5.2.2. The vehicle is placed on a chassis dynamometer and driven through the test cycle specified in Part A of Annex VI to Regulation (EU) No 168/2013 as appropriate for the class of vehicle being tested. Exhaust emissions may be sampled during this operation but the results shall not be used for the purpose of exhaust emission type-approval.

5.2.3. The vehicle is parked in the test area for the minimum period stated in Table Ap3-1.

TABLE AP3-1

SHED test – minimum and maximum soak periods

Engine capacity	Minimum (hours)	Maximum (hours)
$\leq 169 \text{ cm}^3$	6	36
$170 \text{ cm}^3 < \text{engine capacity} \leq 279 \text{ cm}^3$	8	36

Status: Point in time view as at 16/12/2013.

Changes to legislation: There are currently no known outstanding effects for the Commission Delegated Regulation (EU) No 134/2014. (See end of Document for details)

> 280 cm ³	12	36
-----------------------	----	----

5.3. Test phases

5.3.1. Tank breathing (diurnal) evaporative emission test

5.3.1.1. The measuring chamber shall be vented/purged for several minutes immediately before the test until a stable background is obtainable. The chamber mixing fan(s) shall be switched on at this time also.

5.3.1.2. The hydrocarbon analyser shall be set to zero and spanned immediately before the test.

5.3.1.3. The fuel tanks shall be emptied as described in point 5.1.1 and refilled with test fuel at a temperature of between 283,2 K and 287,2 K (10 °C and 14 °C) to 50 ± 2 % of its normal volumetric capacity.

5.3.1.4. The test vehicle shall be brought into the test enclosure with the engine switched off and parked in an upright position. The fuel tank sensors and heating device shall be connected, if necessary. Immediately begin recording the fuel temperature and the air temperature in the enclosure. If a venting/purging fan is still operating, it shall be switched off at this time.

5.3.1.5. The fuel and vapour may be artificially heated to the starting temperatures of 288,7 K (15,5 °C) and 294,2 K (21,0 °C) ± 1 K respectively.

5.3.1.6. As soon as the fuel temperature reaches 287,0 K (14,0 °C):

- (1) Install the fuel filler cap(s);
- (2) Turn off the purge blowers, if not already off at that time;
- (3) Close and seal enclosure doors.

As soon as the fuel reaches a temperature of 288,7 K (15,5 °C) ± 1 K the test procedure shall continue as follows:

- (a) the hydrocarbon concentration, barometric pressure and the temperature shall be measured to give the initial readings $C_{HC, i}$, P_i and T_i for the tank heat build test;
- (b) a linear heat build of 13,8 K or $20 \pm 0,5$ K over a period of 60 ± 2 minutes shall begin. The temperature of the fuel and fuel vapour during the heating shall conform to the result of equation Ap3-1 within $\pm 1,7$ K, or the closest possible function as described in 4.4.3:

For exposed type fuel tanks:

Equations Ap3-1:

$$T_f = 0,3333 \times t + 288,5$$

$$T_v = 0,3333 \times t + 294,0$$

For non-exposed type fuel tanks:

Equations Ap3-2:

$$T_f = 0,2222 \times t + 288,5$$

$$T_v = 0,2222 \times t + 294,0$$

where:

Status: Point in time view as at 16/12/2013.

Changes to legislation: There are currently no known outstanding effects for the Commission Delegated Regulation (EU) No 134/2014. (See end of Document for details)

T_f	=	required temperature of fuel (K);
T_v	=	required temperature of vapour (K);
t	=	time from start of the tank heat build in minutes.

- 5.3.1.7. The hydrocarbon analyser is set to zero and spanned immediately before the end of the test.
- 5.3.1.8. If the heating requirements in point 5.3.1.6. have been met over the 60 ± 2 minute period of the test, the final hydrocarbon concentration in the enclosure is measured ($C_{HC,f}$). The time or elapsed time of this measurement is recorded, together with the final temperature and barometric pressure T_f and p_f .
- 5.3.1.9. The heat source is turned off and the enclosure door unsealed and opened. The heating device and temperature sensor are disconnected from the enclosure apparatus. The vehicle is now removed from the enclosure with the engine switched off.
- 5.3.1.10. To prevent abnormal loading of the canister, fuel tank caps may be removed from the vehicle during the period between the end of the diurnal test phase and the start of the driving cycle. The driving cycle shall begin within 60 minutes of the completion of the breathing loss test.
- 5.3.2. Driving cycle
- 5.3.2.1. ‘Tank breathing losses’ means hydrocarbon emissions caused by temperature changes in the fuel storage and supply. Following the tank breathing losses test, the vehicle is pushed or otherwise manoeuvred onto the chassis dynamometer with the engine switched off. It is then driven through the driving cycle specified for the class of vehicle on test. At the request of the manufacturer, exhaust emissions may be sampled during this operation, but the results shall not be used for the purpose of exhaust emission type-approval.
- 5.3.3. Hot soak evaporative emissions test
- The determination for evaporative emissions is concluded with the measurement of hydrocarbon emissions over a 60-minute hot soak period. The hot soak test shall begin within seven minutes of the completion of the driving cycle specified in point 5.3.2.1.
- 5.3.3.1. Before the completion of the test run, the measuring chamber shall be purged for several minutes until a stable hydrocarbon background is obtained. The enclosure mixing fan(s) shall also be turned on at this time.
- 5.3.3.2. The hydrocarbon analyser shall be set to zero and spanned immediately prior to the test.
- 5.3.3.3. The vehicle shall be pushed or otherwise moved into the measuring chamber with the engine switched off.
- 5.3.3.4. The enclosure doors are closed and sealed gas-tight within seven minutes of the end of the driving cycle.
- 5.3.3.5. A $60 \pm 0,5$ minute hot soak period begins when the chamber is sealed. The hydrocarbon concentration, temperature and barometric pressure are measured to give the initial readings $C_{HC,i}$, P_i and T_i for the hot soak test. These figures are used in the evaporative emission calculation shown in chapter 6.

Status: Point in time view as at 16/12/2013.

Changes to legislation: There are currently no known outstanding effects for the Commission Delegated Regulation (EU) No 134/2014. (See end of Document for details)

- 5.3.3.6. The hydrocarbon analyser shall be zeroed and spanned immediately before the end of the $60 \pm 0,5$ minute test period.
- 5.3.3.7. At the end of the $60 \pm 0,5$ minute test period, measure the hydrocarbon concentration in the chamber. The temperature and the barometric pressure are also measured. These are the final readings C_{HC} , f , p_f and T_f for the hot soak test used for the calculation in chapter 6. This completes the evaporative emission test procedure.
- 5.4. Alternative test procedures
- 5.4.1. At the request of the manufacturer, with the agreement of the technical service and to the satisfaction of the approval authority, alternative methods may be used to demonstrate compliance with the requirements of this Appendix. In such cases, the manufacturer shall satisfy the technical service that the results from the alternative test can be correlated with those resulting from the procedure described in this Annex. This correlation shall be documented and added to the information folder provided for in Article 27 of Regulation (EU) No 168/2013.

6. Calculation of results

- 6.1. The evaporative emission tests described in chapter 5 allow the hydrocarbon emissions from the tank breathing and hot soak phases to be calculated. Evaporative losses from each of these phases is calculated using the initial and final hydrocarbon concentrations, temperatures and pressures in the enclosure, together with the net enclosure volume.

The following formula shall be used:

Equation Ap3-3:

$$M_{HC} = k \cdot V \cdot 10^{-4} \times \left(\frac{C_{HC,f} \times p_f}{T_f} - \frac{C_{HC,i} \times p_i}{T_i} \right)$$

where:

M_{HC}	= mass of hydrocarbon emitted over the test phase (grams);
C_{HC}	= hydrocarbon concentration measured in the enclosure (ppm (volume) C_i equivalent);
V	= net enclosure volume in cubic metres corrected for the volume of the vehicle. If the volume of the vehicle is not determined, a volume of $0,14 \text{ m}^3$ shall be subtracted;
T	= ambient chamber temperature in K;
p	= barometric pressure in kPa;
H/C	= hydrogen to carbon ratio;
$k = 1,2 \times (12 + H / C)$	

where:

i is the initial reading;

f is the final reading;

H/C is taken to be 2,33 for tank breathing losses;

H/C is taken to be 2,20 for hot soak losses. 'Hot soak losses' means hydrocarbon emissions arising from the fuel system of a stationary vehicle after a period of driving (assuming a ratio of $C_1 H_{2,20}$);

- 6.2. Overall results of test

The overall evaporative hydrocarbon mass emission for the vehicle is taken to be:

Status: Point in time view as at 16/12/2013.

Changes to legislation: There are currently no known outstanding effects for the Commission Delegated Regulation (EU) No 134/2014. (See end of Document for details)

Equation Ap3-4:

$$M_{\text{total}} = M_{\text{TH}} + M_{\text{HS}}$$

where:

- M_{total} = overall evaporative mass emissions of the vehicle (grams);
 M_{TH} = evaporative hydrocarbon mass emission for the tank heat build (grams);
 M_{HS} = evaporative hydrocarbon mass emission for the hot soak (grams).

7. **Limit values**

When tested according to this Annex, overall evaporative hydrocarbon mass emission for the vehicle (M_{total}) shall be as specified in Part C of Annex VI to Regulation (EU) No 168/2013.

8. **Further provisions**

At the request of the manufacturer, evaporative emission approval shall be granted without testing if a California Executive Order for the vehicle type with regard to environmental performance for which application is made can be provided to the approval authority.

Status: Point in time view as at 16/12/2013.

Changes to legislation: There are currently no known outstanding effects for the Commission Delegated Regulation (EU) No 134/2014. (See end of Document for details)

Appendix 3.1

Preconditioning requirements for a hybrid application before start of the SHED test

1. Scope

- 1.1. The following preconditioning requirements before starting the SHED test shall apply only to L-category vehicles equipped with a hybrid propulsion.

2. Test methods

- 2.1. Before starting the SHED test procedure, the test vehicles shall be preconditioned as follows:

2.1.1. OVC vehicles.

- 2.1.1.1. As regards OVC vehicles without an operating mode switch, the procedure shall start with the discharge of the electrical energy/power storage device of the vehicle while driving (on the test track, on a chassis dynamometer, etc.) in any of the following conditions:

- (a) at a steady speed of 50 km/h until the fuel-consuming engine of the HEV starts up;
- (b) if a vehicle cannot reach a steady speed of 50 km/h without the fuel-consuming engine starting up, the speed shall be reduced until it can run at a lower steady speed at which the fuel-consuming engine does not start up for a defined time or distance (to be determined by the technical service and the manufacturer);
- (c) in accordance with the manufacturer's recommendation.

The fuel-consuming engine shall be stopped within ten seconds of being automatically started.

- 2.1.1.2. As regards OVC vehicles with an operating mode switch, the procedure shall start with the discharge of the electrical energy/power storage device of the vehicle while driving with the switch in pure electric position (on the test track, on a chassis dynamometer, etc.) at a steady speed of 70 percent \pm 5 percent from the maximum thirty minutes speed of the vehicle. By means of derogation if the manufacturer can prove to the technical service to the satisfaction of the approval authority that the vehicle is physically not capable of achieving the thirty minutes speed the maximum fifteen minute speed may be used instead.

Stopping the discharge occurs in any of the following conditions:

- (a) when the vehicle is not able to run at 65 percent of the maximum thirty minutes speed;
- (b) when the standard on-board instrumentation gives the driver an indication to stop the vehicle;
- (c) after 100 km.

If the vehicle is not equipped with a pure electric mode, the electrical energy/power storage device discharge shall be conducted with the vehicle driving

Status: Point in time view as at 16/12/2013.

Changes to legislation: There are currently no known outstanding effects for the Commission Delegated Regulation (EU) No 134/2014. (See end of Document for details)

(on the test track, on a chassis dynamometer, etc.) under any of the following conditions:

- (a) at a steady speed of 50 km/h until the fuel-consuming engine of the HEV starts up;
- (b) if a vehicle cannot reach a steady speed of 50 km/h without the fuel-consuming engine starting up, the speed shall be reduced until it can run at a lower steady speed at which the fuel-consuming engine does not start up for a defined time or distance (to be determined by the technical service and the manufacturer);
- (c) in accordance with the manufacturer's recommendation.

The engine shall be stopped within ten seconds of being automatically started. By means of derogation if the manufacturer can prove to the technical service to the satisfaction of the approval authority that the vehicle is physically not capable of achieving the thirty minutes speed the maximum fifteen minute speed may be used instead.

2.1.2. NOVC vehicles.

2.1.2.1. As regards NOVC vehicles without an operating mode switch, the procedure shall start with a preconditioning of at least two consecutive complete, applicable test type I driving cycles without soak.

2.1.2.2. As regards NOVC vehicles with an operating mode switch, the procedure shall start with a preconditioning of at least two consecutive complete, applicable driving cycles without soak, with the vehicle running in hybrid mode. If several hybrid modes are available, the test shall be carried out in the mode which is automatically set after the ignition key is turned (normal mode). On the basis of information provided by the manufacturer, the technical service shall ensure that the limit values are complied with in all hybrid modes.

2.1.3. The preconditioning drive shall be carried out according to the type I test cycle in Appendix 6 to Annex II:

2.1.3.1. for OVC vehicles this shall be carried out under the same conditions as specified by Condition B of the type I test in Appendix 11 to Annex II.

2.1.3.2. for NOVC vehicles this shall be carried out under the same conditions as in the type I test.

Status: Point in time view as at 16/12/2013.

Changes to legislation: There are currently no known outstanding effects for the Commission Delegated Regulation (EU) No 134/2014. (See end of Document for details)

Appendix 3.2

Ageing test procedure for evaporative emission control devices

1. Test methods for ageing of evaporative emission control devices

The SHED test shall be conducted with aged evaporative emission control devices fitted. The ageing tests for those devices shall be conducted according to the procedures in this Appendix.

2. Carbon canister ageing

Figure Ap3.2-1

Carbon canister gas flow diagram and ports

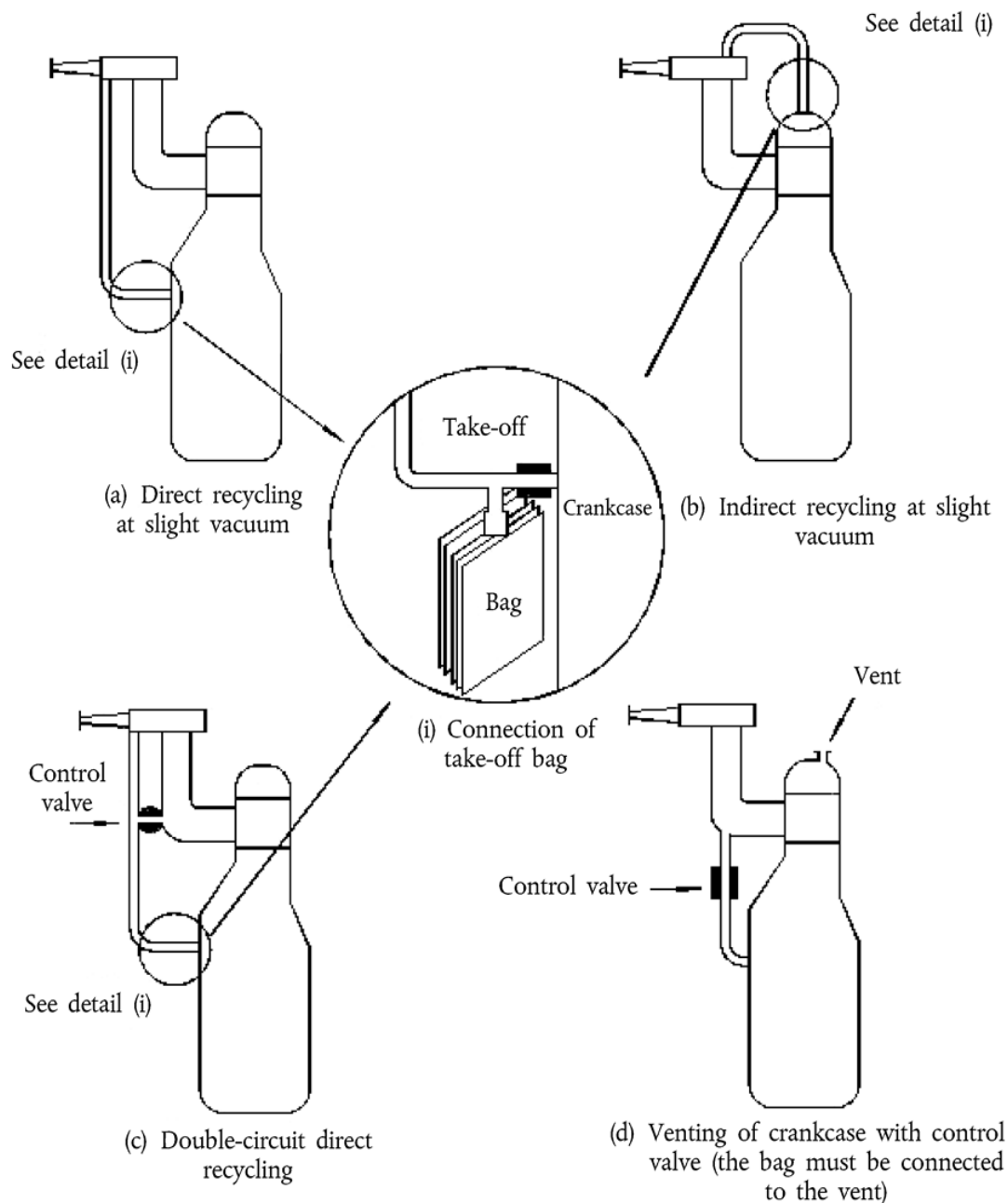

A carbon canister representative of the propulsion family of the vehicle as set out in Annex XI shall be selected as test canister and shall be marked in agreement with the approval authority and the technical service.

2.1. Canister ageing test procedure

In the case of a multiple canister system, each canister shall undergo the procedure separately. The number of test cycles of canister loading and discharging shall correspond to the number set-out in table Ap3.1-1, dwell time and subsequent purging of fuel vapour shall be run to age the test canister at an ambient temperature of 297 ± 2 K as follows:

Status: Point in time view as at 16/12/2013.

Changes to legislation: There are currently no known outstanding effects for the Commission Delegated Regulation (EU) No 134/2014. (See end of Document for details)

- 2.1.1. Canister loading part of the test cycle
- 2.1.1.1. Loading of the canister shall start within one minute of completing the purge portion of the test cycle.
- 2.1.1.2. The (clean air) vent port of the canister shall be open and the purge port shall be capped. A mix by volume of 50 % air and 50 % commercially available petrol or test petrol specified in Appendix 2 to Annex II shall enter through the tank port of the test canister at a flow rate of 40 grams/hour. The petrol vapour shall be generated at a petrol temperature of 313 ± 2 K.
- 2.1.1.3. The test canister shall be loaded each time to $2,0 \pm 0,1$ grams breakthrough detected by:
- 2.1.1.3.1. FID reading (using a mini-SHED or similar) or 5 000 ppm instantaneous reading on the FID occurring at the (clean air) vent port; or
- 2.1.1.3.2. Gravimetric test method using the difference in mass of the test canister charged to $2,0 \pm 0,1$ grams breakthrough and the purged canister.
- 2.1.2. Dwell time
- A five minute dwell period between canister loading and purging as part of the test cycle shall be applied.
- 2.1.3. Canister purging part of the test cycle
- 2.1.3.1. The test canister shall be purged through the purge port and the tank port shall be capped.
- 2.1.3.2. Four hundred canister bed volumes shall be purged at a rate of 24 l/min into the vent port.
- 2.1.4. *TABLE AP3.2-1*

Amount of test cycles of charging and purging the test canister

Vehicle category	Vehicle category name	Number of test cycles referred to in
L1e-A	Powered cycle	45
L3e-AxT (x=1, 2 or 3)	Two-wheel trial motorcycle	
L1e-B	Two-wheel moped	90
L2e	Three-wheel moped	
L3e-AxE (x=1, 2 or 3)	Two-wheel Enduro motorcycle	
L6e-A	Light on-road quad	
L7e-B	Heavy all-terrain quad	170
L3e & L4e ($v_{\max} < 130$ km/h)	Two-wheel motorcycle, with and without side-car	
L5e	Tricycle	
L6e-B	Light quadri-mobile	

Status: Point in time view as at 16/12/2013.

Changes to legislation: There are currently no known outstanding effects for the Commission Delegated Regulation (EU) No 134/2014. (See end of Document for details)

L7e-C	Heavy quadri-mobile	
L3e & L4e ($v_{\max} \geq 130$ km/h)	Two-wheel motorcycle, with and without side-car	300
L7e-A	Heavy on-road quad	

3. Ageing test procedure of evaporative emission control valves, cables and linkages

- 3.1. The durability test shall actuate control valves, cables, and linkages, where applicable, for a minimum of 5 000 cycles.
- 3.2. Alternatively, the aged evaporative emission control parts tested according to point 3.1. may be replaced with ‘golden’ evaporation emission control valves, cables and linkages complying with the requirements of point 3.5. of Annex VI, to be installed on the type IV test vehicle at the choice of the manufacturer prior to start of the SHED test referred to in Appendix 3.

4. Reporting

The manufacturer shall report the results of the tests referred to in points 2 and 3 in a test report drafted according to the template referred to in Article 32(1) of Regulation (EU) No 168/2013.

Status: Point in time view as at 16/12/2013.

Changes to legislation: There are currently no known outstanding effects for the Commission Delegated Regulation (EU) No 134/2014. (See end of Document for details)

Appendix 4

Calibration of equipment for evaporative emission testing

1. Calibration frequency and methods

- 1.1. All equipment shall be calibrated before its initial use and then as often as necessary, and in any case in the month before type-approval testing. The calibration methods to be used are described in this Appendix.

2. Calibration of the enclosure

- 2.1. Initial determination of enclosure internal volume

2.1.1. Before its initial use, the internal volume of the chamber shall be determined as follows. The internal dimensions of the chamber are carefully measured, allowing for any irregularities such as bracing struts. The internal volume of the chamber is determined from these measurements.

2.1.2. The net internal volume is determined by subtracting 0,14 m³ from the internal volume of the chamber. Alternatively, the actual volume of the test vehicle may be subtracted.

2.1.3. The chamber shall be checked as in point 2.3. If the propane mass does not tally to within $\pm 2\%$ with the injected mass, corrective action is required.

- 2.2. Determination of chamber background emissions

This operation determines that the chamber contains no materials that emit significant amounts of hydrocarbons. The check shall be carried out when the enclosure is brought into service, after any operations in it which may affect background emissions and at least once per year.

2.2.1. Calibrate the analyser (if required). The hydrocarbon analyser shall be set to zero and spanned immediately before the test.

2.2.2. Purge the enclosure until a stable hydrocarbon reading is obtained. The mixing fan is turned on, if not already on.

2.2.3. Seal the chamber and measure the background hydrocarbon concentration, temperature and barometric pressure. These are the initial readings C_{HCi} , p_i and T_i used in the enclosure background calculation.

2.2.4. The enclosure is allowed to stand undisturbed with the mixing fan on for four hours.

2.2.5. The hydrocarbon analyser shall be set to zero and spanned immediately before the end of the test.

2.2.6. At the end of this time, use the same analyser to measure the hydrocarbon concentration in the chamber. The temperature and the barometric pressure are also measured. These are the final readings C_{HCf} , P_f and T_f .

2.2.7. Calculate the change in mass of hydrocarbons in the enclosure over the time of the test in accordance with point 2.4. The background emission of the enclosure shall not exceed 0,4 g.

- 2.3. Calibration and hydrocarbon retention test of the chamber

Status: Point in time view as at 16/12/2013.

Changes to legislation: There are currently no known outstanding effects for the Commission Delegated Regulation (EU) No 134/2014. (See end of Document for details)

The calibration and hydrocarbon retention test in the chamber provides a check on the calculated volume in point 2.1. and also measures any leak rate.

- 2.3.1. Purge the enclosure until a stable hydrocarbon concentration is reached. Turn on the mixing fan, if it is not already on. The hydrocarbon analyser shall be calibrated (if necessary) then set to zero and spanned immediately before the test.
- 2.3.2. Seal the enclosure and measure the background concentration, temperature and barometric pressure. These are the initial readings $C_{HC,i}$, p_i and T_i used in the enclosure calibration.
- 2.3.3. Inject approximately 4 grams of propane into the enclosure. The mass of propane shall be measured to an accuracy of $\pm 2\%$ of the measured value.
- 2.3.4. Allow the contents of the chamber to mix for five minutes. The hydrocarbon analyser shall be set to zero and spanned immediately before the following test. Measure the hydrocarbon concentration, temperature and barometric pressure. These are the final readings $C_{HC,f}$, p_f and T_f for the calibration of the enclosure.
- 2.3.5. Using the readings taken in accordance with points 2.3.2 and 2.3.4 and the formula in point 2.4, calculate the mass of propane in the enclosure. This shall be within $\pm 2\%$ of the mass of propane measured in accordance with point 2.3.3.
- 2.3.6. Allow the contents of the chamber to mix for a minimum of four hours. Then measure and record the final hydrocarbon concentration, temperature and barometric pressure. The hydrocarbon analyser shall be set to zero and spanned immediately before the end of the test.
- 2.3.7. Using the formula in 2.4, calculate the hydrocarbon mass from the readings taken in points 2.3.6 and 2.3.2. The mass may not differ by more than 4% from the hydrocarbon mass calculated in accordance with point 2.3.5.

2.4. Calculations

The calculation of net hydrocarbon mass change within the enclosure shall be used to determine the chamber's hydrocarbon background and leak rate. Initial and final readings of hydrocarbon concentration, temperature and barometric pressure are used in the following formula to calculate the mass change:

Equation Ap3-5:

$$M_{HC} = k \times V \times 10^{-4} \times \left(\frac{C_{HC,f} \times p_f}{T_f} - \frac{C_{HC,i} \times p_i}{T_i} \right)$$

where:

- | | |
|----------|--|
| M_{HC} | = mass of hydrocarbon in grams; |
| C_{HC} | = hydrocarbon concentration in the enclosure (ppm carbon (NB: ppm carbon = ppm propane \times 3)); |
| V | = net enclosure volume in cubic metres as measured in accordance with point 2.1.1; |
| T | = ambient temperature in the enclosure, K; |
| p | = barometric pressure in kPa; |
| k | = 17,6; |

where:

i is the initial reading;

Status: Point in time view as at 16/12/2013.

Changes to legislation: There are currently no known outstanding effects for the Commission Delegated Regulation (EU) No 134/2014. (See end of Document for details)

f is the final reading.

3. **Checking of FID hydrocarbon analyser**

3.1. Detector response optimisation

The FID analyser shall be adjusted as specified by the instrument manufacturer. Propane in air shall be used to optimise the response on the most common operating range.

3.2. Calibration of the HC analyser

The analyser shall be calibrated using propane in air and purified synthetic air. A calibration curve shall be established as described in points 4.1 to 4.5.

3.3. Oxygen interference check and recommended limits

The response factor (Rf) for a particular hydrocarbon species is the ratio of the FID C1 reading to the gas cylinder concentration, expressed as ppm C1.

The concentration of the test gas shall be such as to give a response of approximately 80 % of full scale deflection, for the operating range. The concentration shall be known to an accuracy of ± 2 % in reference to a gravimetric standard expressed in volume. In addition, the gas cylinder shall be preconditioned for 24 hours at between 293,2 K and 303,2 K (20 °C and 30 °C).

Response factors shall be determined when introducing an analyser into service and thereafter at major service intervals. The reference gas to be used is propane balanced with purified air which shall be taken to give a response factor of 1,00.

The test gas to be used for oxygen interference and the recommended response factor range are given the following response factor range for Propane and Nitrogen: $0,95 \leq Rf \leq 1,05$.

4. **Calibration of the hydrocarbon analyser**

Each of the normally used operating ranges are calibrated by the following procedure:

- 4.1. Establish the calibration curve by at least five calibration points spaced as evenly as possible over the operating range. The nominal concentration of the calibration gas with the highest concentrations shall be at least 80 % of the full scale.
- 4.2. Calculate the calibration curve by the method of least squares. If the resulting polynomial degree is greater than 3, then the number of calibration points shall be at least the number of the polynomial degree plus 2.
- 4.3. The calibration curve shall not differ by more than 2 % from the nominal value of each calibration gas.
- 4.4. Using the coefficients of the polynomial derived from point 4.2, a table of indicated reading against true concentration shall be drawn up in steps of no greater than 1 % of full scale. This is to be carried out for each analyser range calibrated. The table shall also contain all of the following:
 - (a) date of calibration;
 - (b) span and zero potentiometer readings (where applicable), nominal scale;
 - (c) reference data of each calibration gas used;
 - (d) the actual and indicated value of each calibration gas used together with the percentage differences.

Status: Point in time view as at 16/12/2013.

Changes to legislation: There are currently no known outstanding effects for the Commission Delegated Regulation (EU) No 134/2014. (See end of Document for details)

- 4.5. Alternative technology (e.g. computer, electronically controlled range switch) may be used if it can be shown to the satisfaction of the approval authority that it can ensure equivalent accuracy.

Status: Point in time view as at 16/12/2013.

Changes to legislation: There are currently no known outstanding effects for the Commission Delegated Regulation (EU) No 134/2014. (See end of Document for details)

ANNEX VI

TEST TYPE V REQUIREMENTS: DURABILITY OF POLLUTION-CONTROL DEVICES

Appendix Number	Appendix title	Page
1	The Standard Road Cycle for L-Category Vehicles (SRC-LeCV)	194
2	The USA EPA Approved Mileage Accumulation durability cycle	204

0. Introduction

- 0.1. This Annex describes the procedures for type V testing to verify the durability of pollution-control devices of L-category vehicles in accordance with Article 23(3) of Regulation (EU) No 168/2013.
- 0.2. The type V test procedure includes mileage accumulation procedures to age the test vehicles in a defined and repeatable way and also includes the frequency of applied type I emission verification test procedures conducted before, during and after the mileage accumulation of the test vehicles.

1. General requirements

- 1.1. The test vehicles' powertrain and pollution-control device type fitted on the test vehicles shall be documented and listed by the manufacturer. The list shall include at a minimum such items as the specifications of the propulsion type and its powertrain, where applicable, the exhaust oxygen sensor(s), catalytic converter(s) type, particulate filter(s) or other pollution-control devices, intake and exhaust systems and any peripheral device(s) that may have an impact on the environmental performance of the approved vehicle. This documentation shall be added to the test report.
- 1.2. The manufacturer shall provide evidence of the possible impacts on type V test results of any modification to the emission abatement system configuration, the pollution-control device type specifications or other peripheral device(s) interacting with the pollution-control devices, in production of the vehicle type after environmental performance type-approval. The manufacturer shall provide the approval authority with this documentation and evidence upon request in order to prove that the durability performance of the vehicle type with regard to environmental performance will not be negatively affected by any change in vehicle production, retrospective changes in the vehicle configuration, changes in the specifications of any pollution-control device type, or changes in peripheral devices fitted on the approved vehicle type.
- 1.3. Category L4e motorcycles with side-car shall be exempted from type V durability testing if the manufacturer can provide the evidence and documentation referred to in this Annex for the L3e two-wheel motorcycle on which the assembly of the L4e vehicle was based. In all other cases, the requirements of this Annex shall apply to category L4e motorcycles with side-car.

2. Specific requirements

- 2.1 Test vehicle requirements

Status: Point in time view as at 16/12/2013.

Changes to legislation: There are currently no known outstanding effects for the Commission Delegated Regulation (EU) No 134/2014. (See end of Document for details)

- 2.1.1. The test vehicles used for type V durability testing and in particular the pollution-control and peripheral devices that are relevant for the emission abatement system shall be representative of the vehicle type with regard to environmental performance produced in series and placed on the market.
- 2.1.2. The test vehicles shall be in good mechanical order at the start of mileage accumulation and it shall not have more than 100 km accumulated after it was first started at the end of the production line. The propulsion and pollution-control devices shall not have been used since its manufacture, with the exception of quality control tests and accumulation of the first 100 km.
- 2.1.3. Regardless of the durability test procedure selected by the manufacturer, all pollution-control devices and systems, both including hardware, powertrain software and powertrain calibration, fitted on the test vehicles shall be installed and operating for the entire mileage accumulation period.
- 2.1.4. The pollution-control devices on the test vehicles shall be permanently marked under surveillance of the technical service before the start of mileage accumulation and be listed together with the vehicle identification number, powertrain software and powertrain calibration sets. The manufacturer shall make that list available at the request of the approval authority.
- 2.1.5. Maintenance, adjustments and the use of the controls of the test vehicles shall be as recommended by the manufacturer in the appropriate repair and maintenance information and in the user manual.
- 2.1.6. The durability test shall be conducted with a suitable commercially available fuel at the discretion of the manufacturer. If the test vehicles is/are equipped with a two-stroke engine, lubricating oil shall be used in the proportion and of the grade recommended by the manufacturer in the user manual.
- 2.1.7. The test vehicles' cooling system shall enable the vehicle to operate at temperatures similar to those obtained during normal road use conditions (oil, coolant, exhaust system, etc.).
- 2.1.8. If the durability test is completed on a test track or road, the reference mass of the test vehicle shall be at least equal to that used for type I emission tests conducted on a chassis dynamometer.
- 2.1.9. If approved by the technical service and to the satisfaction of the approval authority, the type V test procedure may be carried out using a test vehicle of which the body style, gear box (automatic or manual) and wheel or tyre size differ from those of the vehicle type for which the environmental performance type-approval is sought.
- 2.2. In the type V test procedure, mileage shall be accumulated by driving the test vehicles either on a test track, on the road or on a chassis dynamometer. The test track or test road shall be selected at the discretion of the manufacturer.
 - 2.2.1. Chassis dynamometer used for mileage accumulation
 - 2.2.1.1. Chassis dynamometers used to accumulate test type V durability mileage shall enable the durability mileage accumulation cycle in Appendix 1 or 2, as applicable, to be carried out.
 - 2.2.1.2. In particular, the dynamometer shall be equipped with systems simulating the same inertia and resistance to progress as those used in the type I emission laboratory test

Status: Point in time view as at 16/12/2013.

Changes to legislation: There are currently no known outstanding effects for the Commission Delegated Regulation (EU) No 134/2014. (See end of Document for details)

in Annex II. Emission analysis equipment is not required for mileage accumulation. The same inertia and flywheel settings and calibration procedures shall be used for the chassis dynamometer referred to in Annex II, used to accumulate mileage with the test vehicles.

2.2.1.3. The test vehicles may be moved to a different bench in order to conduct type I emission verification tests. The mileage accumulated in the type I emission verification tests may be added to the total accumulated mileage.

2.3. The type I emission verification tests before, during and after durability mileage accumulation shall be conducted according to the test procedures for emissions after cold start set out in Annex II. All type I emission verification test results shall be listed and made available to the technical service and to the approval authority upon request. The results of type I emission verification tests at the start and the finish of durability mileage accumulation shall be included in the test report. At least the first and last type I emission verification tests shall be conducted or witnessed by the technical service and reported to the approval authority. The test report shall confirm and state whether the technical service conducted or witnessed the type I emission verification testing.

2.4. Type V test requirements for an L-category vehicle equipped with a hybrid propulsion

2.4.1. For OVC vehicles:

The electrical energy/power storage device may be charged twice a day during mileage accumulation.

For OVC vehicles with an operating mode switch, mileage accumulation shall be driven in the mode which is automatically set after the ignition key is turned (normal mode).

During the mileage accumulation, a change to another hybrid mode is allowed if necessary in order to continue the mileage accumulation, after agreement of the technical service and to the satisfaction of the approval authority. This hybrid mode change shall be recorded in the test report.

Pollutant emissions shall be measured under the same conditions as specified by Condition B of the type I test (points 3.1.3. and 3.2.3.).

2.4.2. For NOVC vehicles:

For NOVC vehicles with an operating mode switch, mileage accumulation shall be driven in the mode which is automatically set after the ignition key is turned on (normal mode).

Pollutant emissions shall be measured in the same conditions as in the type I test.

3. **Test type V, durability test procedure specifications**

The specifications of the three durability test procedures set out in Article 23(3) of Regulation (EU) No 168/2013 are as follows:

3.1. Actual durability testing with full mileage accumulation

The durability test procedure with full mileage accumulation to age the test vehicles shall refer to Article 23(3)(a) of Regulation (EU) No 168/2013. Full mileage accumulation shall mean full completion of the assigned test distance laid down in Part A of Annex VII to Regulation (EU) No 168/2013. by repeating the driving manoeuvres laid down in Appendix 1 or, if applicable in Appendix 2.

Status: Point in time view as at 16/12/2013.

Changes to legislation: There are currently no known outstanding effects for the Commission Delegated Regulation (EU) No 134/2014. (See end of Document for details)

- 3.1.1. The manufacturer shall provide evidence that the emission limits in the applicable type I emission laboratory test cycle, as set out in Part A or B of Annex VI to Regulation (EU) No 168/2013, of the aged test vehicles are not exceeded when starting mileage accumulation, during the accumulation phase and after full mileage accumulation has been finalised.
- 3.1.2. Multiple type I emission tests shall be conducted during the full mileage accumulation phase with a frequency and amount of type I test procedures at the choice of the manufacturer and to the satisfaction of the technical service and approval authority. The type I emission test results shall provide sufficient statistical relevance to identify the deterioration trend, which shall be representative of the vehicle type with regard to environmental performance as placed on the market (see Figure 5-1).

Figure 5-1

Test type V – durability test procedure with full mileage accumulation

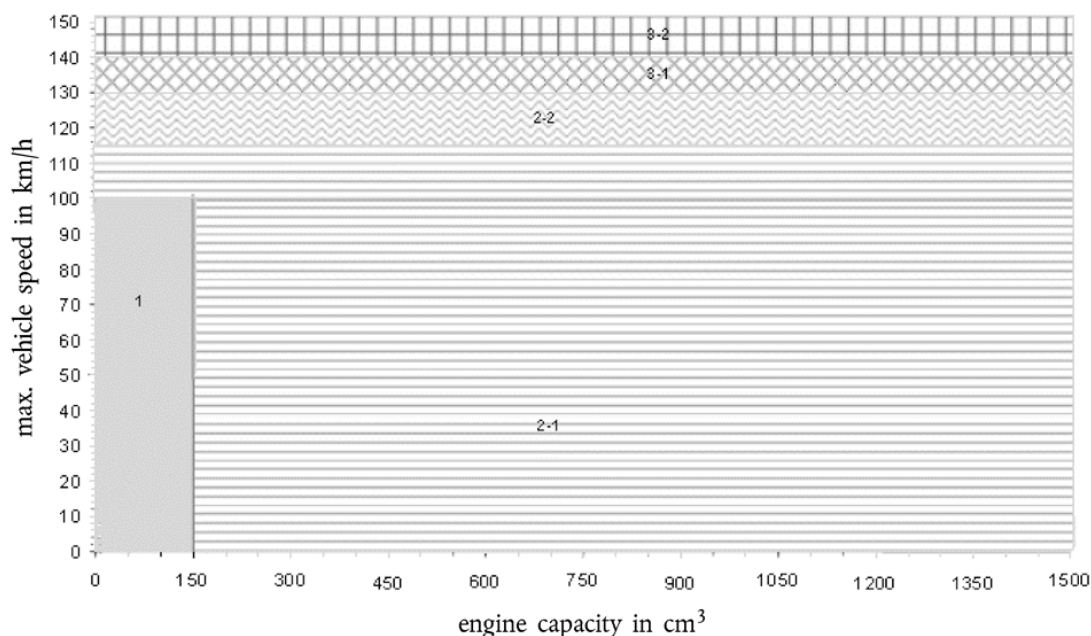

3.2. Actual durability testing with partial mileage accumulation

The durability test procedure for L-category vehicles with partial mileage accumulation shall refer to Article 23(3)(b) of Regulation (EU) No 168/2013. Partial mileage accumulation shall involve completion of a minimum of 50 % of the test distance specified in Part A of Annex VII to Regulation (EU) No 168/2013 and compliance with the stop criteria in point 3.2.3.

- 3.2.1. The manufacturer shall provide evidence that the emission limits in the applicable type I emission laboratory test cycle, as set out in Part A of Annex VI to Regulation (EU) No 168/2013, of the tested aged vehicles are not exceeded at the start of mileage accumulation, during the accumulation phase and after the partial accumulation.
- 3.2.2. Multiple type I emission tests shall be conducted during the partial mileage accumulation phase, with the frequency and number of type I test procedures chosen by the manufacturer. The type I emission test results shall provide sufficient statistical relevance to identify the deterioration trend, which shall be representative of the

Status: Point in time view as at 16/12/2013.

Changes to legislation: There are currently no known outstanding effects for the Commission Delegated Regulation (EU) No 134/2014. (See end of Document for details)

vehicle type with regard to the environmental performance placed on the market (see Figure 5-2).

Figure 5-2

Test type V – accelerated durability test procedure with partial mileage accumulation

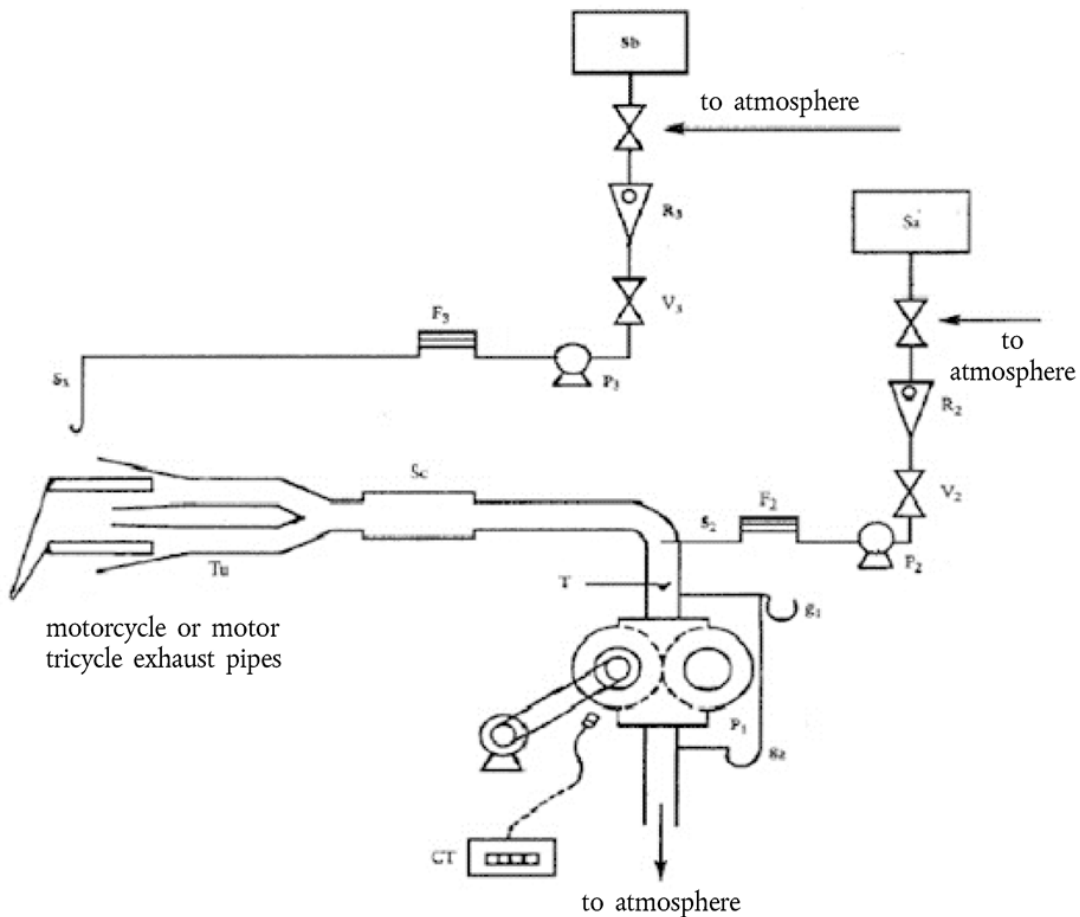

3.2.3. Stop criteria for the durability test procedure with partial mileage accumulation

Partial mileage accumulation may stop if the following criteria are met:

- 3.2.3.1. if a minimum of 50 % of the applicable test distance laid down in Part A of Annex VII to Regulation (EU) No 168/2013 has been accumulated; and
- 3.2.3.2. if all the type I emission verification test results are below the emission limits laid down in Part A of Annex VI to Regulation (EU) No 168/2013 at all times during the partial mileage accumulation phase; or
- 3.2.3.3. if the manufacturer cannot prove that the stop criteria in points 3.2.3.1. and 3.2.3.2. are met, the mileage accumulation shall continue to the point where those criteria are met or to the fully accumulated mileage set out in Part A of Annex VII to Regulation (EU) No 168/2013.
- 3.2.4. Data processing and reporting for the durability test procedure with partial mileage accumulation

Status: Point in time view as at 16/12/2013.

Changes to legislation: There are currently no known outstanding effects for the Commission Delegated Regulation (EU) No 134/2014. (See end of Document for details)

- 3.2.4.1. The manufacturer shall use the arithmetic mean of the type I emission test results at each test interval, with a minimum of two emission tests per test interval. All arithmetic mean type I emissions test results shall be plotted per THC, CO, NO_x, and if applicable NMHC and PM, emission constituent, against accumulation distance rounded to the nearest kilometre.
- 3.2.4.2. The best fit linear line (trend line:
$$y = ax + b$$
) shall be fitted and drawn through all these data points based on the method of least squares. This best-fit straight trend line shall be extrapolated over the full durability mileage laid down in Part A of Annex VII to Regulation (EU) No 168/2013. At the request of the manufacturer, the trend line may start as of 20 % of the durability mileage laid down in Part A of Annex VII to Regulation (EU) No 168/2013, in order to take into account possible run-in effects of the pollution-control devices.
- 3.2.4.3. A minimum of four calculated arithmetic mean data points shall be used to draw each trend line, with the first at, or before, 20 % of the durability mileage laid down in Part A of Annex VII to Regulation (EU) No 168/2013 and the last one at the end of mileage accumulation; at least two other data points shall be equally spaced between the first and final type I test measurement distances.
- 3.2.4.4. The applicable emission limits set out in Part A of Annex VI to Regulation (EU) No 168/2013 shall be plotted in the graphs per emission constituent laid down in points 3.2.4.2. and 3.2.4.3. The plotted trend line shall not exceed these applicable emission limits at any mileage data point. The graph per THC, CO, NO_x, and if applicable NMHC and PM, emission constituent plotted against accumulation distance shall be added to the test report. The list with all the type I emission test results used to establish the best-fit straight trend line shall be made available to the technical service upon request.

Figure A5-3

Status: Point in time view as at 16/12/2013.

Changes to legislation: There are currently no known outstanding effects for the Commission Delegated Regulation (EU) No 134/2014. (See end of Document for details)

Theoretical example of the plotted type I total hydrocarbon (THC) emission test results, the plotted type I THC Euro 4 test limit (170 mg/km) and the best-fit straight trend line of a Euro 4 motorcycle (L3e with $v_{\max} > 130$ km/h), all versus accumulated mileage

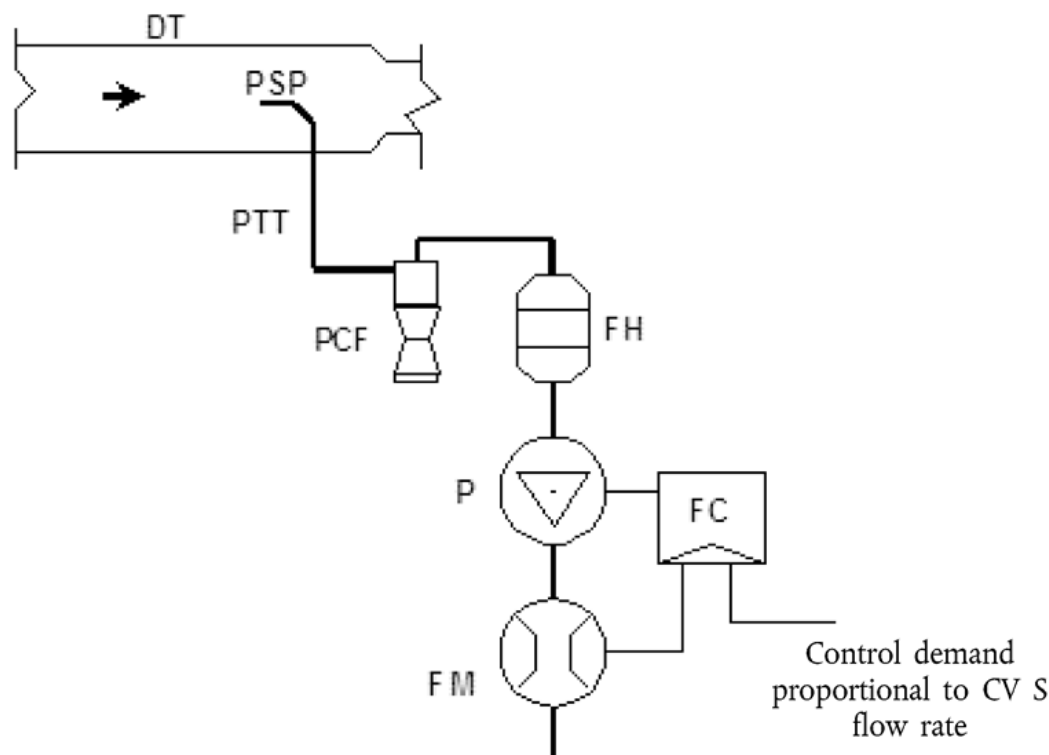

3.2.4.5. Trend line parameters a , x and b of the best-fit straight lines and the calculated pollutant value at the end mileage according to the vehicle category shall be stated in the test report. The graph for all emission constituents shall be plotted in the test report. In the test report it shall also be stated which measurements were taken or witnessed by the technical service and which by the manufacturer.

3.3. The mathematical durability procedure

L-category vehicles using the mathematical durability procedure shall refer to point 3(c) of Article 23 of Regulation (EU) No 168/2013.

3.3.1. The emission results of the vehicle that has accumulated more than 100 km after it was first started at the end of the production line, the applied deterioration factors set out in Part B of Annex VII to Regulation (EU) No 168/2013, and the product of the multiplication of both and the emission limit set out in Annex VI to Regulation (EU) No 168/2013 shall be added to the test report.

3.4. Durability mileage accumulation cycles

One of the following two durability mileage accumulation test cycles shall be conducted to age the test vehicles until the assigned test distance laid down in Part A of Annex VII to Regulation (EU) No 168/2013 is fully completed according to the full mileage accumulation test procedure set out in point 3.1. or partially completed according to the partial mileage accumulation test procedure in point 3.2.:

Status: Point in time view as at 16/12/2013.

Changes to legislation: There are currently no known outstanding effects for the Commission Delegated Regulation (EU) No 134/2014. (See end of Document for details)

3.4.1. The Standard Road Cycle (SRC-LeCV) for L-category vehicles

The Standard Road Cycle (SRC-LeCV) custom tailored for L-category vehicles is the principle durability type V test cycle composed of a set of four mileage accumulation durability cycles. One of these durability mileage accumulation cycles shall be used to accumulate mileage by the test vehicles according to the technical details laid down in Appendix 1.

3.4.2. The USA EPA Approved Mileage Accumulation cycle

At the choice of the manufacturer, the AMA durability mileage accumulation cycle may be conducted as alternative type V mileage accumulation cycle up to and including the last date of registration set out in point 1.5.2. of Annex IV to Regulation (EU) No 168/2013. The AMA durability mileage accumulation cycle shall be conducted according to the technical details laid down in Appendix 2.

3.5. Test type V durability verification testing using ‘golden’ pollution-control devices

3.5.1. The pollution-control devices may be removed from the test vehicles after:

3.5.1.2. full mileage accumulation according to the test procedure in point 3.1. is completed, or

3.5.1.3. partial mileage accumulation according to the test procedure in point 3.2. is completed.

3.5.2. At the choice of the manufacturer, ‘golden’ pollution-control devices may repeatedly be used for durability performance verification and approval demonstration testing on the same vehicle type with regard to the environmental performance by fitting them on (a) representative parent vehicles representing the propulsion family set out in Annex XI, later on in vehicle development.

3.5.3. The ‘golden’ pollution-control devices shall be permanently marked and the marking number, the associated type I test results and the specifications shall be made available to the approval authority upon request.

3.5.4. In addition, the manufacturer shall mark and store new, non-aged pollution-control devices with the same specifications as those of the ‘golden’ pollution-control devices and, in the event of a request under point 3.5.5., make these available also to the approval authority, as a reference base.

3.5.5. The approval authority and technical service shall be given access at any time during or after the environmental performance type-approval process both to the ‘golden’ pollution-control devices and ‘new, non-aged’ pollution-control devices. The approval authority or technical service may request and witness a verification test by the manufacturer or may have the ‘new, non-aged’ and ‘golden’ pollution-control devices tested by an independent test laboratory in a non-destructive way.

Status: Point in time view as at 16/12/2013.

Changes to legislation: There are currently no known outstanding effects for the Commission Delegated Regulation (EU) No 134/2014. (See end of Document for details)

Appendix 1

The Standard Road Cycle for L-Category Vehicles (SRC-LeCV)

1. Introduction

- 1.1. The Standard Road Cycle for L-Category Vehicles (SRC-LeCV) is a representative kilometre accumulation cycle to age L-category vehicles and in particular their pollution-control devices in a defined, repeatable and representative way. The test vehicles may run the SRC-LeCV on the road, on a test track or on a kilometre accumulation chassis dynamometer.
- 1.2. The SRC-LeCV shall consist of five laps of a 6 km course. The length of the lap may be changed to accommodate the length of the kilometre accumulation test track or test road. The SRC-LeCV shall include four different vehicle speed profiles.
- 1.3. The manufacturer may request to be allowed alternatively to perform the next higher numbered test cycle, with the agreement of the approval authority, if it considers that this better represents the real-world use of the vehicle.

2. SRC-LeCV test requirements

- 2.1. If the SRC-LeCV is performed on a kilometre accumulation chassis dynamometer:
 - 2.1.1. the chassis dynamometer shall be equipped with systems equivalent to those used in the type I emission laboratory test set out in Annex II to Regulation (EU) No 168/2013, simulating the same inertia and resistance to progress. Emission analysis equipment shall not be required for mileage accumulation. The same inertia and flywheel settings and calibration procedures shall be used for the chassis dynamometer used to accumulate mileage with the test vehicles set out in Annex II to Regulation (EU) No 168/2013;
 - 2.1.2. the test vehicles may be moved to a different chassis dynamometer in order to conduct type I emission verification tests. This dynamometer shall enable the SRC-LeCV to be carried out;
 - 2.1.3. the chassis dynamometer shall be configured to give an indication after each quarter of the 6 km course has been passed that the test driver or robot driver shall proceed with the next set of actions;
 - 2.1.4. a timer displaying seconds shall be made available for execution of the idling periods;
 - 2.1.5. the distance travelled shall be calculated from the number of rotations of the roller and the roller circumference.
- 2.2. If the SRC-LeCV is not performed on a kilometre accumulation chassis dynamometer:
 - 2.2.1. the test track or test road shall be selected at the discretion of the manufacturer to the satisfaction of the approval authority;
 - 2.2.2. the track or road selected shall be shaped so as not to significantly hinder the proper execution of the test instructions;
 - 2.2.3. the route used shall form a loop to allow continuous execution;

Status: Point in time view as at 16/12/2013.

Changes to legislation: There are currently no known outstanding effects for the Commission Delegated Regulation (EU) No 134/2014. (See end of Document for details)

- 2.2.4. track lengths which are multiples, half or quarter of this length shall be permitted. The length of the lap may be changed to accommodate the length of the mileage accumulation track or road;
- 2.2.5. four points shall be marked, or landmarks identified, on the track or road which equate to quarter intervals of the lap;
- 2.2.6. the distance accumulated shall be calculated from the number of cycles required to complete the test distance. This calculation shall take into account the length of the road or track and chosen lap length. Alternatively, an electronic means of accurately measuring the actual distance travelled may be used. The odometer of the vehicle shall not be used.
- 2.2.7. Examples of test track configurations:
Figure Ap1-1

Simplified graphic of possible test track configurations

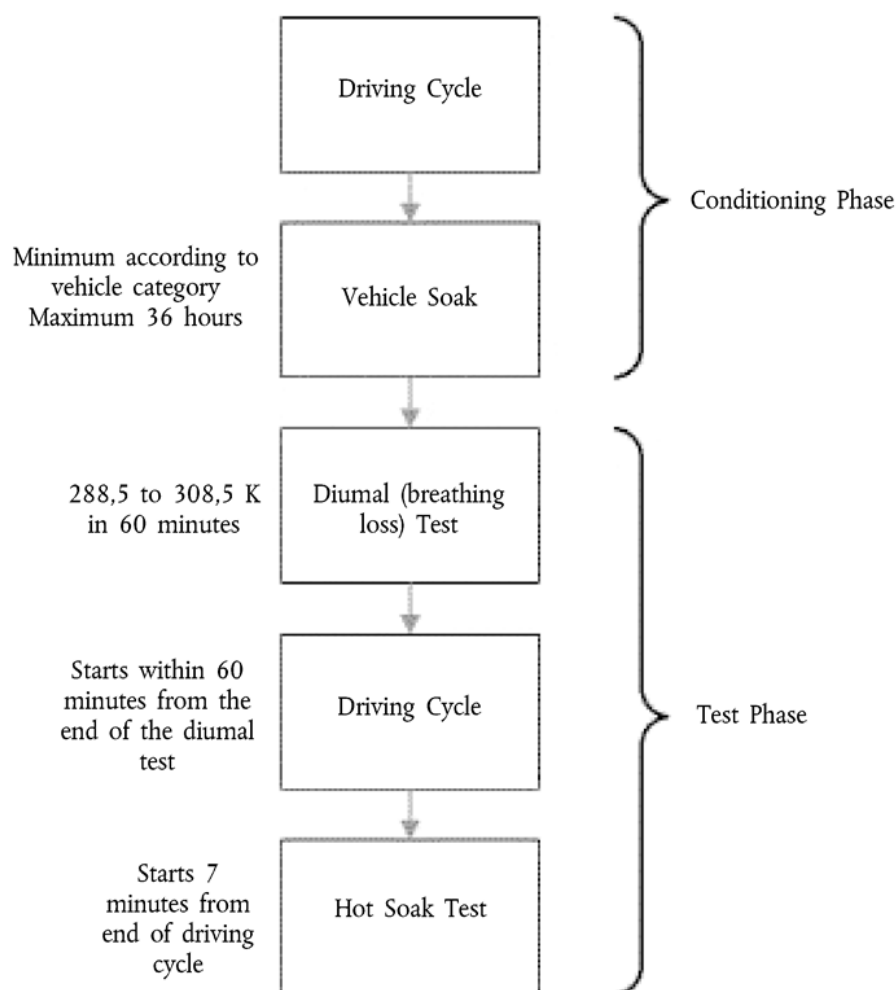

- 2.3. The total distance travelled shall be the applicable durability mileage set out in Part A of Annex VII to Regulation (EU) No 168/2013, plus one complete SRC-LeCV sub-cycle (30 km).

Status: Point in time view as at 16/12/2013.

Changes to legislation: There are currently no known outstanding effects for the Commission Delegated Regulation (EU) No 134/2014. (See end of Document for details)

- 2.4. No stopping is permitted mid-cycle. Any stops for type I emission tests, maintenance, soak periods, refuelling, etc. shall be performed at the end of one complete SRC-LeCV sub-cycle, i.e. the culmination of step 47 in Table Ap1-4. If the vehicle travels to the testing area under its own power, only moderate acceleration and deceleration shall be used and the vehicle shall not be operated at full throttle.
- 2.5. The four cycles shall be selected on the basis of the maximum design vehicle speed of the L-category vehicle and the engine capacity or, in the case of pure electric or hybrid propulsions, the maximum design speed of the vehicle and the net power.
- 2.6. For the purpose of accumulating mileage in the SRC-LeCV, the L-vehicle categories shall be grouped as follows:

TABLE AP1-1

L-vehicle category groups for the SRC-LeCV

Cycle	WMTC Class	Vehicle maximum design speed (km/h)	Vehicle engine capacity (PI)	Net power (kW)
1	1	$v_{\max} \leq 50$ km/h	$V_d \leq 50$ cm ³	≤ 6 kW
2		50 km/h $< v_{\max} < 100$ km/h	50 cm ³ $< V_d < 150$ cm ³	< 14 kW
3	2	100 km/h $\leq v_{\max} < 130$ km/h	$V_d \geq 150$ cm ³	≥ 14 kW
4	3	130 km/h $\leq v_{\max}$	—	—

where:

V_d = engine displacement volume in cm³
 v_{\max} = maximum design vehicle speed in km/h

2.7. SRC-LeCV general driving instructions

2.7.1. Idle instructions

2.7.1.1. If not already stopped, the vehicle shall decelerate to a full stop and the gear shifted to neutral. The throttle shall be fully released and ignition shall remain on. If a vehicle is equipped with a stop-start system or, in the case of a hybrid electric vehicle, the combustion engine switches off when the vehicle is stationary; it shall be ensured that the combustion engine continues to idle.

2.7.1.2. The vehicle shall not be prepared for the following action in the test cycle until the full required idle duration has passed.

2.7.2. Acceleration instructions:

2.7.2.1. accelerate to the target vehicle speed using the following sub-action methodologies:

2.7.2.1.1. : normal medium part-load acceleration, up to moderate approximately half throttle.

Status: Point in time view as at 16/12/2013.

Changes to legislation: There are currently no known outstanding effects for the Commission Delegated Regulation (EU) No 134/2014. (See end of Document for details)

- 2.7.2.1.2. : high part-load acceleration up to full throttle.
hard
- 2.7.2.2. if moderate acceleration is no longer able to provide a noticeable increase in actual vehicle speed to reach a target vehicle speed, then hard acceleration shall be used and ultimately full throttle.
- 2.7.3. Deceleration instructions:
- 2.7.3.1. decelerate from either the previous action or from the maximum vehicle speed attained in the previous action, whichever is lower.
- 2.7.3.2. if the next action sets the target vehicle speed at 0 km/h, the vehicle shall be stopped before proceeding.
- 2.7.3.3. moderate deceleration: normal let-off of the throttle; brakes, gears and clutch may be used as required.
- 2.7.3.4. coast-through deceleration: full let-off of the throttle, clutch disengaged and in gear, no foot/hand control actuated, no brakes applied. If the target speed is 0 km/h (idle) and if the actual vehicle speed is ≤ 5 km/h, the clutch may be disengaged, the gear shifted to neutral and the brakes used in order to prevent engine stall and to entirely stop the vehicle. An upshift is not allowed during a coast-through deceleration. The rider may downshift to increase the braking effect of the engine. During gear changes, extra care shall be afforded to ensure that the gear change is performed promptly, with minimum (i.e. < 2 seconds) coasting in neutral gear, clutch and partial clutch use. The vehicle manufacturer may request to extend this time with the agreement of the approval authority if absolutely necessary.
- 2.7.3.5. coast-down deceleration: deceleration shall be initiated by de-clutching (i.e. separating the drive from the wheels) without the use of brakes until the target vehicle speed is reached.
- 2.7.4. Cruise instruction:
- 2.7.4.1. if the following action is 'cruise', the vehicle may be accelerated to attain the target vehicle speed.
- 2.7.4.2. the throttle shall continue to be operated as required to attain and remain at the target cruising vehicle speed.
- 2.7.5. A driving instruction shall be performed in its entirety. Additional idling time, acceleration to above, and deceleration to below, the target vehicle speed is permitted in order to ensure that actions are performed fully.
- 2.7.6. Gear changes should be carried out according to the guidance laid down in point 4.5.5. of Appendix 9 of Annex II. Alternatively, guidance provided by the manufacturer to the consumer may be used if approved by the approval authority.
- 2.7.7. Where the test vehicle cannot reach the target vehicle speeds set out in the applicable SRC-LeCV, it shall be operated at wide open throttle and using other available options to attain maximum design speed.
- 2.8. SRC-LeCV test steps

The SRC-LeCV test shall consist of the following steps:

Status: Point in time view as at 16/12/2013.

Changes to legislation: There are currently no known outstanding effects for the Commission Delegated Regulation (EU) No 134/2014. (See end of Document for details)

- 2.8.1. the maximum design speed of the vehicle and either the engine capacity or net power, as applicable, shall be obtained;
- 2.8.2. the required SRC-LeCV shall be selected from Table Ap1-1 and the required target vehicle speeds and detailed driving instructions from Table Ap1-3.
- 2.8.3. the column ‘decelerate by’ shall indicate the delta vehicle speed to be subtracted either from the previously attained target vehicle speed or from the maximum design vehicle speed, whichever is lower.

Example lap 1:

vehicle No 1: L1e-B low-speed moped with maximum design vehicle speed of 25 km/h, subject to SRC-LeCV No 1

vehicle No 2: L1e-B high-speed moped with maximum design vehicle speed of 45 km/h, subject to SRC-LeCV No 1

Table Ap1-2

Example L1e-B low-speed moped and L1e-B high-speed moped, actual vs. target vehicle speeds

Lap	Sub-lap	Action	Time(s)	To/at(Target vehicle speed in km/h)	By(Delta vehicle speed in km/h)	Vehicle No 1(Actual vehicle speed in km/h)	Vehicle No 2(Actual vehicle speed in km/h)
1	1st 1/4						
		Stop & Idle	10				
		Accelerate		35		25	35
		Cruise		35		25	35
	2nd 1/4						
		Decelerate			15	10	20
		Accelerate		35		25	35
		Cruise		35		25	35
	3rd 1/4						
		Decelerate			15	10	20
		Accelerate		45		25	45
		Cruise		45		25	45
	4th 1/4						
		Decelerate			20	5	25
		Accelerate		45		25	45
		Cruise		45		25	45

Status: Point in time view as at 16/12/2013.

Changes to legislation: There are currently no known outstanding effects for the Commission Delegated Regulation (EU) No 134/2014. (See end of Document for details)

- 2.8.4. A table of target vehicle speeds shall be prepared indicating the nominal target vehicle speeds set out in Tables Ap1-3 and Ap-4 and the attainable target vehicle speeds of the vehicle in a format preferred by the manufacturer to the satisfaction of the approval authority.
- 2.8.5. In accordance with point 2.2.5., quarter divisions of the lap length shall be marked or identified on the test track or road, or a system shall be used to indicate the distance being passed on the chassis dynamometer.
- 2.8.6. After each sub-lap is passed, the required list of actions of Tables Ap1-3 and Ap-4 shall be performed in order and in accordance with point 2.7 regarding the general driving instructions to or at the next target vehicle speed.
- 2.8.7. The maximum attained vehicle speed may deviate from the maximum design vehicle speed depending on the type of acceleration required and track conditions. Therefore, during the test the actual attained vehicle speeds shall be monitored to see if the target vehicle speeds are being met as required. Special attention shall be paid to peak vehicle speeds and cruise vehicle speeds close to the maximum design vehicle speed and the subsequent vehicle speed differences in the decelerations.
- 2.8.8. Where a significant deviation is consistently found when performing multiple sub-cycles, the target vehicle speeds shall be adjusted in the table in point 2.8.4. The adjustment needs to be made only when starting a sub-cycle and not in real time.
- 2.9. SRC-LeCV detailed test cycle description
- 2.9.1. Graphical overview of the SRC-LeCV
Figure Ap1-2

Status: Point in time view as at 16/12/2013.

Changes to legislation: There are currently no known outstanding effects for the Commission Delegated Regulation (EU) No 134/2014. (See end of Document for details)

SRC-LeCV, example distance accumulation characteristics for all four cycles

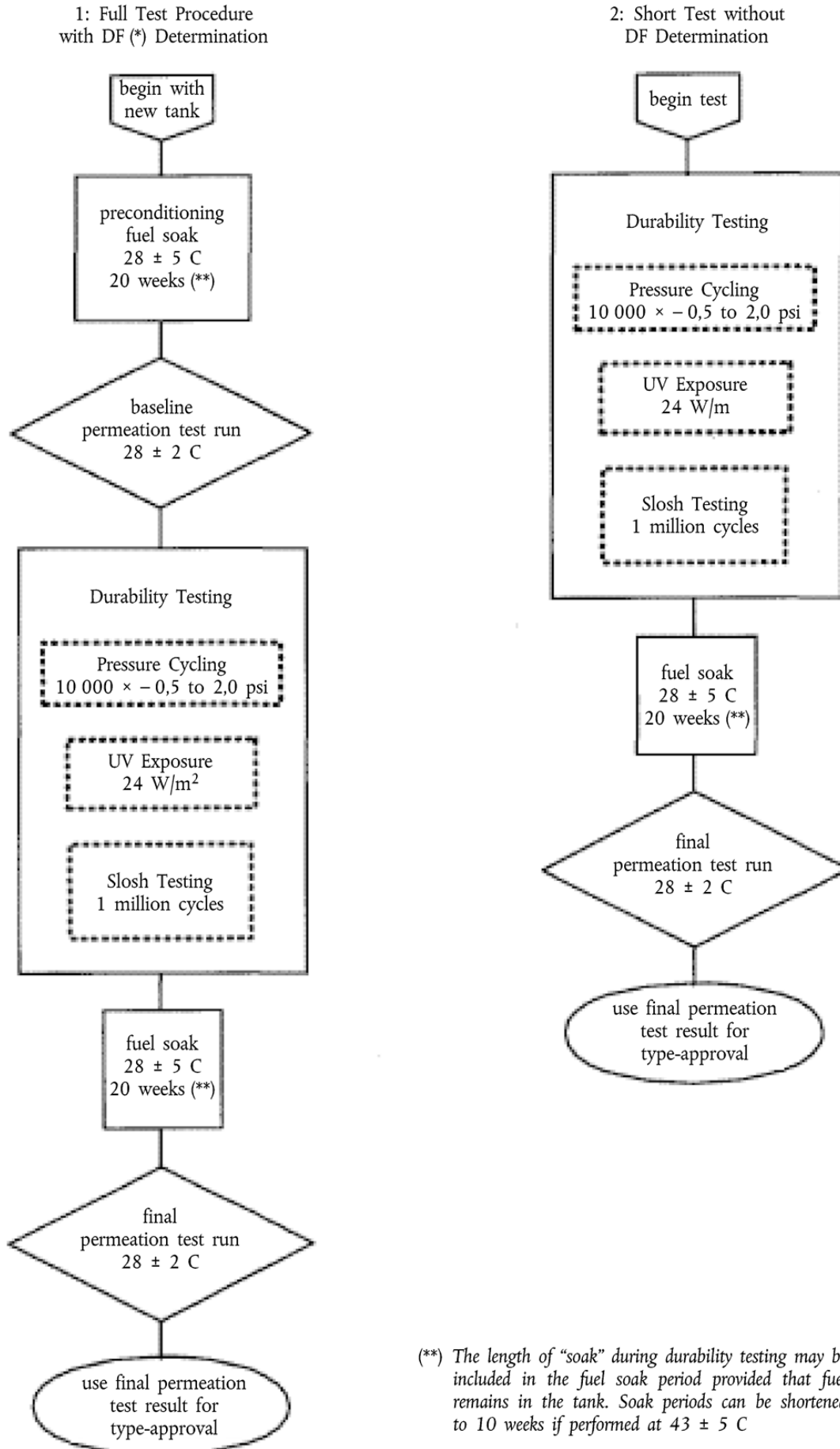

Status: Point in time view as at 16/12/2013.

Changes to legislation: There are currently no known outstanding effects for the Commission Delegated Regulation (EU) No 134/2014. (See end of Document for details)

2.9.2. SRC-LeCV detailed cycle instructions

TABLE AP1-3

Actions and sub-actions for each cycle and sub-cycle, lap 1, 2 and 3

Cycle:					1		2		3		4	
Lap	Sub-lap	Action	Sub-action	Time (s)	To/at	By	To/at	By	To/at	By	To/at	By
1	1st 1/4				(km/h)							
		Stop & Idle		10								
		Accelerate	Hard		35		50		55		90	
		Cruise			35		50		55		90	
	2nd 1/4											
		Decelerate	Moderate			15		15		15		15
		Accelerate	Moderate		35		50		55		90	
		Cruise			35		50		55		90	
	3rd 1/4											
		Decelerate	Moderate			15		15		15		15
		Accelerate	Moderate		45		60		75		100	
		Cruise			45		60		75		100	
	4th 1/4											
		Decelerate	Moderate			20		10		15		20
		Accelerate	Moderate		45		60		75		100	
		Cruise			45		60		75		100	
2	1st 1/2											
		Decelerate	Cut-through		0		0		0		0	
		Stop & Idle		10								
		Accelerate	Hard		50		100		100		130	
		Decelerate	Cut-down			10		20		10		15

Status: Point in time view as at 16/12/2013.

Changes to legislation: There are currently no known outstanding effects for the Commission Delegated Regulation (EU) No 134/2014. (See end of Document for details)

		Optional acceleration	Hard		40		80		90		115	
		Cruise			40		80		90		115	
	2nd 1/2											
		Deceleration	Moderate			15		20		25		35
		Acceleration	Moderate		50		75		80		105	
		Cruise			50		75		80		105	
3	1st 1/2											
		Deceleration	Moderate			25		15		15		25
		Acceleration	Moderate		50		90		95		120	
		Cruise			50		90		95		120	
	2nd 1/2											
		Deceleration	Moderate			25		10		30		40
		Acceleration	Moderate		45		70		90		115	
		Cruise			45		70		90		115	

TABLE API-4

Actions and sub-actions for each cycle and sub-cycle, lap 4 and 5

Cycle:					1		2		3		4	
Lap	Sub-lap	Action	Sub-action	Time (s)	To/at	By	To/at	By	To/at	By	To/at	By
4	1st 1/2				(km/h)							
		Deceleration	Moderate			20		20		25		35
		Acceleration	Moderate		45		70		90		115	
		Deceleration	Fast-down			20		15		15		15
		Optional acceleration	Moderate		35		55		75		100	
		Cruise			35		55		75		100	
	2nd 1/2											
		Deceleration	Moderate			10		10		10		20
		Acceleration	Moderate		45		65		80		105	
		Cruise			45		65		80		105	

Status: Point in time view as at 16/12/2013.

Changes to legislation: There are currently no known outstanding effects for the Commission Delegated Regulation (EU) No 134/2014. (See end of Document for details)

5	1st 1/4			(km/ h)						
		Decelerate	Fast-through	0		0		0		0
		Stop & Idle		45						
		Accelerate	Hard	30		55		70		90
		Cruise		30		55		70		90
	2nd 1/4									
		Decelerate	Moderate		15		15		20	25
		Accelerate	Moderate	30		55		70		90
		Cruise		30		55		70		90
	3rd 1/4									
		Decelerate	Moderate		20		25		20	25
		Accelerate	Moderate	20		45		65		80
		Cruise		20		45		65		80
	4 th 1/4									
		Decelerate	Moderate		10		15		15	15
		Accelerate	Moderate	20		45		65		80
		Cruise		20		45		65		80
		Decelerate	Fast-through	0		0		0		0

2.9.3. Soak procedures in the SRC-LeCV

The SRC-LeCV soak procedure shall consist of the following steps:

- 2.9.3.1. a full SRC-LeCV sub-cycle (approximately 30 km) shall be completed;
- 2.9.3.2. a test type I emission test may be performed if deemed necessary for statistical relevance;
- 2.9.3.3. any required maintenance shall be undertaken and the test vehicle may be refuelled;
- 2.9.3.4. the test vehicle shall be set to idle with the combustion engine running for a minimum of one hour with no user input;
- 2.9.3.5. the propulsion of the test vehicle shall be turned off;

Status: Point in time view as at 16/12/2013.

Changes to legislation: There are currently no known outstanding effects for the Commission Delegated Regulation (EU) No 134/2014. (See end of Document for details)

- 2.9.3.6. the test vehicle shall be cooled down and soaked under ambient conditions for a minimum of six hours (or four hours with a fan and lubrication oil at ambient temperature);
- 2.9.3.7. the vehicle may be refuelled and mileage accumulation shall be resumed as required at lap 1, sub-lap 1 of the SRC-LeCV sub-cycle in Table Ap1-3.
- 2.9.3.8. the SRC-LeCV soak procedure shall not replace the regular soak time for type I emission tests laid down in Annex II. The SRC-LeCV soak procedure may be coordinated so as to be performed after each maintenance interval or after each emission laboratory test.
- 2.9.3.9 Test type V soak procedure for actual durability testing with full mileage accumulation
- 2.9.3.9.1. During the full mileage accumulation phase set out in point 3.1 of Annex VI, the test vehicles shall undergo a minimum number of soak procedures set out in Table Ap1-3. These procedures shall be evenly distributed over the accumulated mileage.
- 2.9.3.9.2. The number of soak procedures to be conducted during the full mileage accumulation phase shall be determined according to the following table:

Table Ap1-3

Number of soak procedures depending on the SRC-LeCV in Table Ap1-1

SRC-LeCV, cycle No	Minimum number of test type V soak procedures
1 & 2	3
3	4
4	6

- 2.9.3.10. Test type V soak procedure for actual durability testing with partial mileage accumulation

During the partial mileage accumulation phase set out in point 3.2 of Annex VI, the test vehicles shall undergo four soak procedures as set out in point 3.1. These procedures shall be evenly distributed over the accumulated mileage.

Appendix 2

The USA EPA Approved Mileage Accumulation durability cycle (AMA)

1. Introduction

- 1.1. The Approved Mileage Accumulation durability cycle (AMA) by the environmental protection agency (EPA) of the United States of America (USA) is a mileage accumulation cycle used to age test vehicles and their pollution-control devices in a way that is repeatable but significantly less representative for the EU fleet and traffic situation than the SRC-LeCV. The AMA test cycle is to be phased out but it may be used in a transitional period up to and including the date of last registration set out in point 1.5.2. of Annex IV to Regulation (EU) No 168/2013, pending the confirmation in the environmental effect study referred to in Article 23(4) of Regulation (EU) No 168/2013. The L-category test vehicles may run the test cycle on the road, on a test track or on a kilometre accumulation chassis dynamometer.
- 1.2. The AMA test cycle shall be completed by repeating the AMA sub-cycle in point 2 until the applicable durability mileage in Part A of Annex VII to Regulation (EU) No 168/2013 has been accumulated.
- 1.3. The AMA test cycle shall be composed of 11 sub-sub-cycles covering six kilometres each.

2. AMA test cycle requirements

- 2.1. For the purpose of accumulating mileage in the AMA test cycle, the L-category vehicles shall be grouped as follows:

Table Ap2-1

Grouping of L-category vehicles for the purpose of the AMA mileage accumulation test

L-category vehicle class	Engine capacity (cm ³)	v _{max} (km/h)
I	< 150	Not applicable
II	≥ 150	≤ 130
III	≥ 150	>130

- 2.2. If the AMA test cycle is performed on a kilometre accumulation chassis dynamometer, the distance travelled shall be calculated from the number of rotations of the roller and the roller circumference.
- 2.3. One AMA test sub-cycle shall be performed as follows:
- 2.5.1. *Figure Ap2-1*

Status: Point in time view as at 16/12/2013.

Changes to legislation: There are currently no known outstanding effects for the Commission Delegated Regulation (EU) No 134/2014. (See end of Document for details)

Driving schedule AMA test sub-sub-cycle

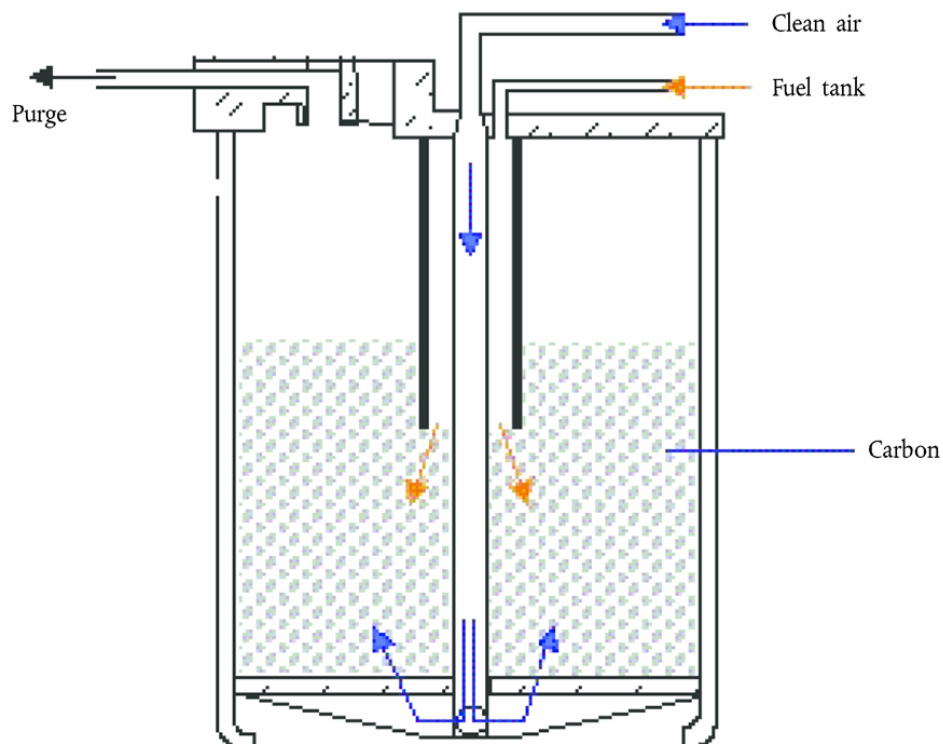

2.5.2. The AMA test cycle consisting of 11 sub-sub-cycles shall be driven at the following sub-sub-cycle vehicle speeds:

Table Ap2-2

Maximum vehicle speed in one AMA sub-cycle

Sub-sub-cycle No	Class I vehicle(km/h)	Class II vehicle(km/h)	Class III vehicleOption I (km/h)	Class III vehicleOption II (km/h)
1	65	65	65	65
2	45	45	65	45
3	65	65	55	65
4	65	65	45	65
5	55	55	55	55
6	45	45	55	45
7	55	55	70	55
8	70	70	55	70
9	55	55	46	55
10	70	90	90	90

Status: Point in time view as at 16/12/2013.

Changes to legislation: There are currently no known outstanding effects for the Commission Delegated Regulation (EU) No 134/2014. (See end of Document for details)

Table Ap2-2

Maximum vehicle speed in one AMA sub-cycle

11	70	90	110	110
----	----	----	-----	-----

- 2.5.3. Manufacturers may select one of two cycle vehicle speed options for class III L-category vehicles, completing the entire procedure on their selected option.
- 2.5.4. During the first nine AMA sub-sub-cycles, the test vehicle is stopped four times with the engine idling each time for 15 seconds.
- 2.5.5. The AMA sub-cycle shall consist of five decelerations in each sub-sub-cycle, dropping from cycle speed to 30 km/h. The test vehicle shall then gradually be accelerated again until the cycle speed shown in Table Ap2-2 is attained.
- 2.5.6. The 10th sub-sub-cycle shall be carried out at a steady speed according to the L-category vehicle class as referred in Table Ap2-1.
- 2.5.7. The 11th sub-sub-cycle shall begin with a maximum acceleration from stop point up to lap speed. At halfway, the brakes are applied normally until the test vehicle comes to a stop. This shall be followed by an idle period of 15 seconds and a second maximum acceleration. This completes one AMA sub-cycle.
- 2.5.8. The schedule shall then be restarted from the beginning of the AMA sub-cycle.
- 2.5.9. At the manufacturer's request, and with the agreement of the approval authority, an L-category vehicle type may be placed in a higher class provided it is capable of complying with all aspects of the procedure for the higher class.
- 2.5.10. At the manufacturer's request, and with the agreement of the approval authority, should the L-category vehicle be unable to attain the specified cycle speeds for that class, the L-category vehicle type shall be placed in a lower class. If the vehicle is unable to achieve the cycle speeds required for this lower class, it shall attain the highest possible speed during the test and full throttle shall be applied if necessary to attain that vehicle speed.

Status: Point in time view as at 16/12/2013.

Changes to legislation: There are currently no known outstanding effects for the Commission Delegated Regulation (EU) No 134/2014. (See end of Document for details)

ANNEX VII

Test type VII requirements: CO₂ emissions, fuel consumption, electric energy consumption and electric range

Appendix Number	Appendix title	Page
1.	Method of measuring carbon dioxide emissions and fuel consumption of vehicles powered by a combustion engine only	211
2.	Method of measuring the electric energy consumption of a vehicle powered by an electric powertrain only	215
3.	Method of measuring the carbon dioxide emissions, fuel consumption, electric energy consumption and driving range of vehicles powered by a hybrid electric powertrain	218
3.1.	Electrical energy/power storage device State Of Charge (SOC) profile for an Externally chargeable Hybrid Electric Vehicle (OVC HEV) in a type VII test	234
3.2.	Method for measuring the electricity balance of the battery of OVC and NOVC HEV	235
3.3.	Method of measuring the electric range of vehicles powered by an electric powertrain only or by a hybrid electric powertrain and the OVC range of vehicles powered by a hybrid electric powertrain	236

1. Introduction

- 1.1. This Annex sets out requirements with regard to energy efficiency of L-category vehicles, in particular with respect to the measurements of CO₂ emissions, fuel or energy consumption as well as the electric range of a vehicle.
- 1.2. The requirements laid down in this Annex apply to the following tests of L-category vehicles equipped with associated powertrain configurations:

Status: Point in time view as at 16/12/2013.

Changes to legislation: There are currently no known outstanding effects for the Commission Delegated Regulation (EU) No 134/2014. (See end of Document for details)

- (a) the measurement of the emission of carbon dioxide (CO₂) and fuel consumption, the measurement of electric energy consumption and the electric range of L-category vehicles powered by a combustion engine only or by a hybrid electric powertrain;
- (b) the measurement of electric energy consumption and electric range of L-category vehicles powered by an electric powertrain only.

2. Specification and tests

2.1. General

The components liable to affect CO₂ emissions and fuel consumption or the electric energy consumption shall be so designed, constructed and assembled as to enable the vehicle, in normal use, despite the vibrations to which it may be subjected, to comply with the provisions of this Annex. The test vehicles shall be properly maintained and used.

2.2. Description of tests for vehicles powered by a combustion engine only

2.2.1. The emissions of CO₂ and fuel consumption shall be measured according to the test procedure described in Appendix 1. Vehicles which do not attain the acceleration and maximum speed values required in the test cycle shall be operated with the accelerator control fully depressed until they reach the required operating curve again. Deviations from the test cycle shall be recorded in the test report. The test vehicle shall be properly maintained and used.

2.2.2. For CO₂ emissions, the test results shall be expressed in grams per kilometre (g/km) rounded to the nearest whole number.

2.2.3. Fuel consumption values shall be expressed in litres per 100 km in the case of petrol, LPG, ethanol (E85) and diesel or in kg and m³ per 100 km in the case of hydrogen, NG/biomethane and H₂NG. The values shall be calculated according to point 1.4.3. of Annex II by the carbon balance method, using the measured emissions of CO₂ and the other carbon-related emissions (CO and HC). The results shall be rounded to one decimal.

2.2.4. The appropriate reference fuels as set out in Appendix 2 to Annex II shall be used for testing.

For LPG, NG/biomethane, H₂NG, the reference fuel used shall be that chosen by the manufacturer for the measurement of the propulsion unit performance in accordance with Annex X. The fuel chosen shall be specified in the test report according to the template set out in Article 32(1) of Regulation (EU) No 168/2013.

For the purpose of the calculation referred in point 2.2.3., the fuel consumption shall be expressed in appropriate units and the following fuel characteristics shall be used:

- (a) density: measured on the test fuel according to ISO 3675:1998 or an equivalent method. For petrol and diesel fuel, the density measured at 288,2 K (15 °C) and 101,3 kPa shall be used; for LPG, natural gas, H₂NG and hydrogen, a reference density shall be used, as follows:

0,538 kg/litre for LPG;

0,654 kg/m³ for NG⁽⁹⁾ / biogas;

Equation 7-1:

$$\frac{1,256 \times A + 136}{0,654 \times A}$$

Status: Point in time view as at 16/12/2013.

Changes to legislation: There are currently no known outstanding effects for the Commission Delegated Regulation (EU) No 134/2014. (See end of Document for details)

for H₂NG (with A being the quantity of NG/biomethane in the H₂NG mixture, expressed in percent by volume for H₂NG);

0,084 kg/m³ for hydrogen

(b) hydrogen-carbon ratio: fixed values will be used, as follows:

C₁:1,89O_{0,016} for E5 petrol;

C₁:1,86O_{0,005} for diesel;

C₁:2525 for LPG (liquefied petroleum gas);

C₁:4 for NG (natural gas) and biomethane;

C₁:2,74O_{0,385} for ethanol (E85).

2.3. Description of tests for vehicles powered by an electric powertrain only

2.3.1. The technical service in charge of the tests shall conduct the measurement of the electric energy consumption according to the method and test cycle described in Appendix 6 to Annex II.

2.3.2. The technical service in charge of the tests shall measure the electric range of the vehicle according to the method described in Appendix 3.3.

2.3.2.1. The electric range measured by this method shall be the only one referred to in promotional material.

2.3.2.2. Category L1e vehicles designed to pedal referred to in Article 2(94) shall be exempted from the electric range test.

2.3.3. Electric energy consumption shall be expressed in Watt hours per kilometre (Wh/km) and the range in kilometres, both rounded to the nearest whole number.

2.4. Description of tests for vehicles powered by a hybrid electric powertrain

2.4.1. The technical service in charge of the tests shall measure the CO₂ emissions and the electric energy consumption according to the test procedure described in Appendix 3.

2.4.2. The test results for CO₂ emissions shall be expressed in grams per kilometre (g/km) rounded to the nearest whole number.

2.4.3. The fuel consumption, expressed in litres per 100 km (in the case of petrol, LPG, ethanol (E85) and diesel) or in kg and m³ per 100 km (in the case of NG/biomethane, H₂NG and hydrogen), shall be calculated according to point 1.4.3. of Annex II by the carbon balance method using the CO₂ emissions measured and the other carbon-related emissions (CO and HC). The results shall be rounded to the first decimal place.

2.4.4. For the purpose of the calculation referred to in point 2.4.3., the prescriptions and reference values of point 2.2.4. shall apply.

2.4.5. If applicable, electric energy consumption shall be expressed in Watt hours per kilometre (Wh/km), rounded to the nearest whole number.

2.4.6. The technical service in charge of the tests shall measure the electric range of the vehicle according to the method described in Appendix 3.3. The result shall be expressed in kilometre, rounded to the nearest whole number.

The electric range measured by this method shall be the only one referred to in promotional material and used for the calculations in Appendix 3.

2.5. Interpretation of test results

- 2.5.1. The CO₂ value or the value of electric energy consumption adopted as the type-approval value shall be that declared by the manufacturer if this is not exceeded by more than 4 percent by the value measured by the technical service. The measured value may be lower without any limitations.

In the case of vehicles powered by a combustion engine only which are equipped with periodically regenerating systems as defined in Article 2(16), the results are multiplied by the factor K_i obtained from Appendix 13 to Annex II before being compared with the declared value.

- 2.5.2. If the measured value of CO₂ emissions or electric energy consumption exceeds the manufacturer's declared CO₂ emissions or electric energy consumption value by more than 4 percent, another test shall be run on the same vehicle.

Where the average of the two test results does not exceed the manufacturer's declared value by more than 4 percent, the value declared by the manufacturer shall be taken as the type-approval value.

- 2.5.3. If, in the event of another test being run, the average still exceeds the declared value by more than 4 percent, a final test shall be run on the same vehicle. The average of the three test results shall be taken as the type-approval value.

3. **Modification and extension of approval of the approved type**

- 3.1. For all approved types, the approval authority that approved the type shall be notified of any modification of it. The approval authority may then either:

3.1.1. consider that the modifications made are unlikely to have an appreciable adverse effect on the CO₂ emissions and fuel or electric energy consumption values and that the original environmental performance approval will be valid for the modified vehicle type with regard to the environmental performance, or

3.1.2. require a further test report from the technical service responsible for conducting the tests in accordance with point 4.

3.2. Confirmation or extension of approval, specifying the alterations, shall be communicated by the procedure referred to in Article 35 of Regulation (EU) No 168/2013.

3.3. The approval authority that grants the extension of the approval shall assign a serial number for such an extension according to the procedure set out in Article 35 of Regulation (EU) No 168/2013.

4. **Conditions of extension of vehicle environmental performance type-approval**

- 4.1. Vehicles powered by an internal combustion engine only, except those equipped with a periodically regenerating emission-control system

A type-approval may be extended to vehicles produced by the same manufacturer that are of the same type or of a type that differs with regard to the following characteristics in Appendix 1, provided the CO₂ emissions measured by the technical service do not exceed the type-approved value by more than 4 percent:

- 4.1.1. reference mass;
- 4.1.2. maximum authorised mass.;

Status: Point in time view as at 16/12/2013.

Changes to legislation: There are currently no known outstanding effects for the Commission Delegated Regulation (EU) No 134/2014. (See end of Document for details)

- 4.1.3. type of bodywork;
- 4.1.4. overall gear ratios;
- 4.1.5. engine equipment and accessories;
- 4.1.6. engine revolutions per kilometre in highest gear with an accuracy of $\pm 5\%$.
- 4.2. Vehicles powered by an internal combustion engine only and equipped with a periodically regenerating emission-control system.

The type-approval may be extended to vehicles produced by the same manufacturer that are of the same type or of a type that differs with regard to the characteristics in Appendix 1, as referred to in points 4.1.1. to 4.1.6., without exceeding the propulsion family characteristics of Annex XI, provided the CO₂ emissions measured by the technical service do not exceed the type-approved value by more than 4 percent, where the same K_i factor is applicable.

The type-approval may also be extended to vehicles of the same type, but with a different K_i factor, provided the corrected CO₂ value measured by the technical service does not exceed the type-approved value by more than 4 percent.

- 4.3. Vehicles powered by an electric powertrain only

Extensions may be granted after agreement with the approval authority.

- 4.4. Vehicles powered by a hybrid electric powertrain

The type-approval may be extended to vehicles of the same type or of a type that differs with regard to the following characteristics in Appendix 3 provided the CO₂ emissions and the electric energy consumption measured by the technical service do not exceed the type-approved value by more than 4 percent:

- 4.4.1. reference mass;
- 4.4.2. maximum authorised mass;
- 4.4.3. type of bodywork;
- 4.4.4. type and number of propulsion batteries. Where multiple batteries are fitted, e.g. to extend the range extrapolation of the measurement, the base configuration, taking into account the capacities and the way in which the batteries are connected (in parallel, not in series), shall be deemed sufficient.
- 4.5. Where any other characteristic is changed, extensions may be granted after agreement with the approval authority.

5. **Special provisions**

Vehicles produced in the future with new energy-efficient technologies may be subject to complementary test programmes, to be specified at a later stage. Such testing will enable manufacturers to demonstrate the advantages of the technologies.

Appendix 1

Method of measuring carbon dioxide emissions and fuel consumption of vehicles powered by a combustion engine only

1. Specification of the test

- 1.1. The carbon dioxide (CO₂) emissions and fuel consumption of vehicles powered by a combustion engine only shall be determined according to the procedure for the type I test in Annex II in force at the time of the approval of the vehicle.
- 1.2. In addition to the CO₂ emission and fuel consumption results for the entire type I test, CO₂ emissions and fuel consumption shall also be determined separately for parts 1, 2 and 3, if applicable, by using the applicable type I test procedure in force at the time of the approval of the vehicle in accordance with point 1.1.1. of Annex IV to Regulation (EU) No 168/2013.
- 1.3. In addition to the conditions in Annex II in force at the time of the approval of the vehicle, the following conditions shall apply:
 - 1.3.1. Only the equipment necessary for the operation of the vehicle during the test shall be in use. If there is a manually controlled device for the engine intake air temperature, it shall be in the position prescribed by the manufacturer for the ambient temperature at which the test is performed. In general, the auxiliary devices required for the normal operation of the vehicle shall be in use.
 - 1.3.2. If the radiator fan is temperature-controlled, it shall be in normal operating condition. The passenger compartment heating system, if present, shall be switched off, as shall any air-conditioning system, but the compressor for such systems shall be functioning normally.
 - 1.3.3. If a super-charger is fitted, it shall be in normal operating condition for the test conditions.
 - 1.3.4. All lubricants shall be those recommended by the manufacturer of the vehicle and shall be specified in the test report.
 - 1.3.5. The widest tyre shall be chosen, except where there are more than three tyre sizes, in which case the second widest shall be chosen. The pressures shall be indicated in the test report.
- 1.4. Calculation of CO₂ and fuel consumption values
 - 1.4.1. The mass emission of CO₂, expressed in g/km, shall be calculated from the measurements taken in accordance with the provisions of point 6 of Annex II.
 - 1.4.1.1. For this calculation, the density of CO₂ shall be assumed to be Q_{CO₂} = 1,964 g/litre.
 - 1.4.2. The fuel consumption values shall be calculated from the hydrocarbon, carbon monoxide and carbon dioxide emission measurements taken in accordance with the provisions of point 6 of Annex II in force at the time of the approval of the vehicle.
 - 1.4.3. Fuel consumption (FC), expressed in litres per 100 km (in the case of petrol, LPG, ethanol (E85) and diesel) or in kg per 100 km (in the case of an alternative fuel vehicle

Status: Point in time view as at 16/12/2013.

Changes to legislation: There are currently no known outstanding effects for the Commission Delegated Regulation (EU) No 134/2014. (See end of Document for details)

propelled with NG/biomethane, H₂NG or hydrogen) is calculated using the following formulae:

- 1.4.3.1. for vehicles with a positive ignition engine fuelled with petrol (E5):

Equation Ap1-1:

$$FC = (0,118 / D) \times ((0,848 \times HC) + (0,429 \times CO) + (0,273 \times CO_2))$$

;

- 1.4.3.2. for vehicles with a positive ignition engine fuelled with LPG:

Equation Ap1-2:

$$FC_{norm} = (0,1212 / 0,538) \times ((0,825 \times HC) + (0,429 \times CO) + (0,273 \times CO_2))$$

.

If the composition of the fuel used for the test differs from that assumed for the calculation of normalised consumption, a correction factor (cf) may be applied at the manufacturer's request, as follows:

Equation Ap1-3:

$$FC_{norm} = (0,1212 / 0,538) \times (cf) \times ((0,825 \times HC) + (0,429 \times CO) + (0,273 \times CO_2))$$

.

The correction factor is determined as follows:

Equation Ap1-4:

$$cf = 0,825 + 0,0693 \times n_{actual}$$

;

where:

$$n_{actual} = \text{the actual H/C ratio of the fuel used;}$$

- 1.4.3.3. for vehicles with a positive ignition engine fuelled with NG/biomethane:

Equation Ap1-5:

$$FC_{norm} = (0,1336 / 0,654) \times ((0,749 \times HC) + (0,429 \times CO) + (0,273 \times CO_2))$$

in m³;

- 1.4.3.4. for vehicles with a positive ignition engine fuelled by H₂NG:

Equation Ap1-6:

$$FC = \frac{910,4 \times A + 13600}{44655 \times A^2 + 667,08 \times A} \left(\frac{7848 \times A}{9104 \times A^2 + 136} \times HC + 0,429 \times CO + 0,273 \times CO_2 \right)$$

in m³;

- 1.4.3.5. for vehicles fuelled with gaseous hydrogen:

Status: Point in time view as at 16/12/2013.

Changes to legislation: There are currently no known outstanding effects for the Commission Delegated Regulation (EU) No 134/2014. (See end of Document for details)

Equation Ap1-7:

$$FC = 0,024 \times \frac{V}{d} \times \left[\frac{1}{Z_2} \times \frac{p_2}{T_2} - \frac{1}{Z_1} \times \frac{p_1}{T_1} \right]$$

For vehicles fuelled with gaseous or liquid hydrogen, the manufacturer may alternatively, with the prior agreement of the approval authority, choose either the formula:

Equation Ap1-8:

$$FC = 0,1 \times (0,1119 \times H_2O + H_2)$$

or a method in accordance with standard protocols such as SAE J2572.

1.4.3.6. for vehicles with a compression ignition engine fuelled with diesel (B5):

Equation Ap1-9:

$$FC = (0,116 / D) \times ((0,861 \times HC) + (0,429 \times CO) + (0,273 \times CO_2))$$

;

1.4.3.7. for vehicles with a positive ignition engine fuelled with ethanol (E85):

Equation Ap1-10:

$$FC = (0,1742 / D) \times ((0,574 \times HC) + (0,429 \times CO) + (0,273 \times CO_2))$$

.

1.4.4. In these formulae:

FC	= the fuel consumption in litres per 100 km in the case of petrol, ethanol, LPG, diesel or biodiesel, in m ³ per 100 km in the case of natural gas and H ₂ NG or in kg per 100 km in the case of hydrogen.
HC	= the measured emission of hydrocarbons in mg/km
CO	= the measured emission of carbon monoxide in mg/km
CO ₂	= the measured emission of carbon dioxide in g/km
H ₂ O	= the measured emission of water (H ₂ O) in g/km
H ₂	= the measured emission of hydrogen (H ₂) in g/km
A	= the quantity of NG/biomethane in the H ₂ NG mixture, expressed in percent by volume
D	= the density of the test fuel.

In the case of gaseous fuels, D is the density at 15 °C and at 101,3 kPa ambient pressure:

d	= theoretical distance covered by a vehicle tested under the type I test in km
p ₁	= pressure in gaseous fuel tank before the operating cycle in Pa
p ₂	= pressure in gaseous fuel tank after the operating cycle in Pa
T ₁	= temperature in gaseous fuel tank before the operating cycle in K
T ₂	= temperature in gaseous fuel tank after the operating cycle in K
Z ₁	= compressibility factor of the gaseous fuel at p ₁ and T ₁
Z ₂	= compressibility factor of the gaseous fuel at p ₂ and T ₂
V	= inner volume of the gaseous fuel tank in m ³

The compressibility factor shall be obtained from the following table:

Status: Point in time view as at 16/12/2013.

Changes to legislation: There are currently no known outstanding effects for the Commission Delegated Regulation (EU) No 134/2014. (See end of Document for details)

Table A p1-1

Compressibility factor Z_x of the gaseous fuel

T(k) \ p(bar)	5	100	200	300	400	500	600	700	800	900
33	0,8589	10,508	18,854	26,477	33,652	40,509	47,119	53,519	59,73	65,759
53	0,9651	0,9221	14,158	18,906	23,384	27,646	31,739	35,697	39,541	43,287
73	0,9888	0,9911	12,779	16,038	19,225	22,292	25,247	28,104	30,877	33,577
93	0,997	10,422	12,334	14,696	17,107	19,472	21,771	24,003	26,172	28,286
113	10,004	10,659	12,131	13,951	15,86	17,764	19,633	21,458	23,239	24,978
133	10,019	10,757	11,99	13,471	15,039	16,623	18,19	19,73	21,238	22,714
153	10,026	10,788	11,868	13,123	14,453	15,804	17,15	18,479	19,785	21,067
173	10,029	10,785	11,757	12,851	14,006	15,183	16,361	17,528	18,679	19,811
193	10,03	10,765	11,653	12,628	13,651	14,693	15,739	16,779	17,807	18,82
213	10,028	10,705	11,468	12,276	13,111	13,962	14,817	15,669	16,515	17,352
233	10,035	10,712	11,475	12,282	13,118	13,968	14,823	15,675	16,521	17,358
248	10,034	10,687	11,413	12,173	12,956	13,752	14,552	15,35	16,143	16,929
263	10,033	10,663	11,355	12,073	12,811	13,559	14,311	15,062	15,808	16,548
278	10,032	10,64	11,3	11,982	12,679	13,385	14,094	14,803	15,508	16,207
293	10,031	10,617	11,249	11,897	12,558	13,227	13,899	14,57	15,237	15,9
308	10,03	10,595	11,201	11,819	12,448	13,083	13,721	14,358	14,992	15,623
323	10,029	10,574	11,156	11,747	12,347	12,952	13,559	14,165	14,769	15,37
338	10,028	10,554	11,113	11,68	12,253	12,83	13,41	13,988	14,565	15,138
353	10,027	10,535	11,073	11,617	12,166	12,718	13,272	13,826	14,377	14,926

Status: Point in time view as at 16/12/2013.

Changes to legislation: There are currently no known outstanding effects for the Commission Delegated Regulation (EU) No 134/2014. (See end of Document for details)

Appendix 2

Method of measuring the electric energy consumption of a vehicle powered by an electric powertrain only

1. Test sequence

- 1.1. Electric energy consumption of pure electric vehicles shall be determined according to the procedure for the type I test in Annex II in force at the time of the approval of the vehicle. For this purpose, a pure vehicle shall be classified according to its maximum attainable design vehicle speed.

If the vehicle has several driving modes which may be selected by the driver, the operator shall select that which best matches the target curve.

2. Test method

2.1. Principle

The following test method shall be used for measuring of the electric energy consumption, expressed in Wh/km:

2.2. *TABLE AP2-1*

Parameters, units and accuracy of measurement

Parameter	Units	Accuracy	Resolution
Time	s	0,1 s	0,1 s
Distance	m	± 0,1 percent	1 m
Temperature	K	± 1 K	1 K
Speed	km/h	± 1 percent	0,2 km/h
Mass	kg	± 0,5 percent	1 kg
Energy	Wh	± 0,2 percent	Class 0,2 s according to IEC ^a 687

^a International Electrotechnical Commission.

2.3. Test vehicle

2.3.1. Condition of the vehicle

- 2.3.1.1. The vehicle tyres shall be inflated to the pressure specified by the vehicle manufacturer when the tyres are at ambient temperature.
- 2.3.1.2. The viscosity of the oils for the mechanical moving parts shall conform to the vehicle manufacturer's specification.
- 2.3.1.3. The lighting, signalling and auxiliary devices shall be off, except those required for the testing and usual day-time operation of the vehicle.
- 2.3.1.4. All energy storage systems for other than traction purposes (electric, hydraulic, pneumatic, etc.) shall be charged to their maximum level as specified by the manufacturer.

Status: Point in time view as at 16/12/2013.

Changes to legislation: There are currently no known outstanding effects for the Commission Delegated Regulation (EU) No 134/2014. (See end of Document for details)

2.3.1.5. If the batteries are operated above the ambient temperature, the operator shall follow the procedure recommended by the vehicle manufacturer in order to keep the battery temperature in the normal operating range.

The manufacturer shall be in a position to attest that the thermal management system of the battery is neither disabled nor reduced.

2.3.1.6. The vehicle shall have travelled at least 300 km in the seven days before the test with the batteries installed for the test.

2.3.2. Classification of the pure electric test vehicle in the type I test cycle.

In order to measure its electric consumption in the type I test cycle, the test vehicle shall be classified according to the achievable maximum design vehicle speed thresholds only, set-out in point 4.3. of Annex II.

2.4. Operation mode

All the tests are conducted at a temperature of between 293,2 K and 303,2 K (20 °C and 30 °C).

The test method includes the four following steps:

- (a) initial charge of the battery;
- (b) two runs of the applicable type I test cycle;
- (c) charging the battery;
- (d) calculation of the electric energy consumption.

If the vehicle moves between the steps, it shall be pushed to the next test area (without regenerative recharging).

2.4.1. Initial charge of the battery

Charging the battery consists of the following procedures:

2.4.1.1. Discharge of the battery

The battery is discharged while the vehicle is driven (on the test track, on a chassis dynamometer, etc.) at a steady speed of 70 percent \pm 5 percent of the maximum design vehicle speed, as determined according to the test procedure in Appendix 1 to Annex X.

Discharging shall stop:

- (a) when the vehicle is unable to run at 65 percent of the maximum thirty minutes speed, or
- (b) when the standard on-board instrumentation indicates that the vehicle should be stopped, or
- (c) after 100 km.

By means of derogation if the manufacturer can prove to the technical service to the satisfaction of the approval authority that the vehicle is physically not capable of achieving the thirty minutes speed the maximum fifteen minute speed may be used instead.

2.4.1.2. Application of a normal overnight charge

The battery shall be charged according to the following procedure:

Status: Point in time view as at 16/12/2013.

Changes to legislation: There are currently no known outstanding effects for the Commission Delegated Regulation (EU) No 134/2014. (See end of Document for details)

2.4.1.2.1. Normal overnight charge procedure

The charge shall be carried out:

- (a) with the on-board charger if fitted;
- (b) with an external charger recommended by the manufacturer, using the charging pattern prescribed for normal charging;
- (c) in an ambient temperature of between 293,2 K and 303,2 K (20 °C and 30 °C).

This procedure excludes all types of special charges that could be automatically or manually initiated, e.g. equalisation or servicing charges.

The vehicle manufacturer shall declare that no special charge procedure has occurred during the test.

2.4.1.2.2. End-of-charge criteria

The end-of-charge criteria shall correspond to a charging time of 12 hours except where the standard instrumentation indicates clearly that the battery is not yet fully charged, in which case:

Equation Ap2-1:

$$\text{the maximum time is} = \frac{3 \times \text{claimed battery capacity (Wh)}}{\text{mains power supply (W)}}$$

2.4.1.2.3. Fully charged battery

Propulsion batteries shall be deemed as fully charged when they have been charged according to the overnight charge procedure until the end-of-charge criteria are fulfilled.

2.4.2. Application of the type I test cycle and measurement of the distance

The end of charging time t_0 (plug off) shall be reported.

The chassis dynamometer shall be set according to the method in point 4.5.6. of Annex II.

Starting within four hours of t_0 , the applicable type I test shall be run twice on a chassis dynamometer, following which the distance covered in km (D_{test}) is recorded. If the manufacturer can demonstrate to the approval authority that twice the type I test distance can physically not be attained by the vehicle, the test cycle shall be conducted once and subsequently followed by a partial second test run. The second test run may stop if the minimum state of charge of the propulsion battery is reached as referred to in Appendix 3.1.

2.4.3. Charge of the battery

The test vehicle shall be connected to the mains within 30 minutes of the second run of the applicable type I test cycle.

The vehicle shall be charged according to the normal overnight charge procedure in point 2.4.1.2.

The energy measurement equipment, placed between the mains socket and the vehicle charger, measures the energy charge E delivered from the mains and its duration.

Charging shall stop 24 hours after the end of the previous charging time (t_0).

Note:

Status: Point in time view as at 16/12/2013.

Changes to legislation: There are currently no known outstanding effects for the Commission Delegated Regulation (EU) No 134/2014. (See end of Document for details)

In the event of a mains power cut, the 24 hour period may be extended in line with the duration of the cut. The validity of the charge shall be discussed between the technical services of the approval laboratory and the vehicle manufacturer to the satisfaction of the approval authority.

2.4.4. Electric energy consumption calculation

Energy E in Wh and charging time measurements are to be recorded in the test report.

The electric energy consumption c shall be determined using the formula:

Equation Ap2-2:

$$c = \frac{E}{D_{\text{test}}}$$

(expressed in Wh/km and rounded to the nearest whole number)

where D_{test} is the distance covered during the test (in km).

Appendix 3

Method of measuring the carbon dioxide emissions, fuel consumption, electric energy consumption and driving range of vehicles powered by a hybrid electric powertrain

1. Introduction

- 1.1. This Appendix lays down specific provisions on the type-approval of hybrid electric L-category vehicles (HEV) as regards measuring carbon dioxide emissions, fuel consumption, electric energy consumption and driving range.
- 1.2. As a general principle for type VII tests, HEVs shall be tested according to the specified type I test cycles and requirements and in particular Appendix 6 to Annex II, except where modified by this Appendix.
- 1.3. OVC (externally chargeable) HEVs shall be tested under Conditions A and B.

The test results under Conditions A and B and the weighted average referred to in point 3 shall be given in the test report.

- 1.4. Driving cycles and gear-shift points
 - 1.4.1. The driving cycle in Annex VI to Regulation (EU) No 168/2013 and Appendix 6 to Annex II to this Regulation applicable at the time of approval of the vehicle shall be used, including the gear-shifting points in point 4.5.5. of Annex II.
 - 1.4.4. For vehicle conditioning, a combination of the driving cycles in Appendix 6 to Annex II applicable at the time of approval of the vehicle shall be used as laid down in this Appendix.

2. Categories of hybrid electric vehicles (HEV)

TABLE AP3-1

Vehicle charging	Off-Vehicle Charging ^a (OVC)		Not-off-vehicle Charging ^b (NOVC)	
	Without	With	Without	With
Operating mode switch				

^a Also known as 'externally chargeable'.

^b Also known as 'not externally chargeable'.

3. OVC (externally chargeable) HEV without an operating mode switch

- 3.1. Two type I tests shall be performed under the following conditions:
 - (a) condition A: the test shall be carried out with a fully charged electrical energy/power storage device;
 - (b) condition B: the test shall be carried out with an electrical energy/power storage device in minimum state of charge (maximum discharge of capacity).

The profile of the state of charge (SOC) of the electrical energy/power storage device at different stages of the test is set out in Appendix 3.1.

Status: Point in time view as at 16/12/2013.

Changes to legislation: There are currently no known outstanding effects for the Commission Delegated Regulation (EU) No 134/2014. (See end of Document for details)

3.2. Condition A

3.2.1. The procedure shall start with the discharge of the electrical energy/power storage device in accordance with point 3.2.1.1.:

3.2.1.1. Discharge of the electrical energy/power storage device

The electrical energy/power storage device of the vehicle is discharged while driving (on the test track, on a chassis dynamometer, etc.) in any of the following conditions:

- at a steady speed of 50 km/h until the fuel-consuming engine starts up,
- if a vehicle cannot reach a steady speed of 50 km/h without the fuel-consuming engine starting up, the speed shall be reduced until it can run at a lower steady speed at which the fuel-consuming engine does not start up for a defined time or distance (to be determined by the technical service and the manufacturer to the satisfaction of the approval authority),
- in accordance with the manufacturer's recommendation.

The fuel-consuming engine shall be stopped within ten seconds of being automatically started.

3.2.2. Conditioning of the vehicle

3.2.2.1. The test vehicle shall be preconditioned by conducting the applicable type I test cycle in combination with the applicable gear-shifting in point 4.5.5. of Annex II.

3.2.2.2. After this preconditioning and before testing, the vehicle shall be kept in a room in which the temperature remains relatively constant between 293,2 and 303,2 K (20 °C and 30 °C). This conditioning shall be carried out for at least six hours and continue until the temperatures of the engine oil and coolant, if any, are within ± 2 K of the temperature of the room, and the electrical energy/power storage device is fully charged as a result of the charging in point 3.2.2.4.

3.2.2.3. During soak, the electrical energy/power storage device shall be charged in accordance with the normal overnight charging procedure described in point 3.2.2.4.

3.2.2.4. Application of a normal overnight charge

The electrical energy/power storage device shall be charged according to the following procedure:

3.2.2.4.1. Normal overnight charge procedure

The charging shall be carried out as follows:

- (a) with the on-board charger, if fitted or
- (b) with an external charger recommended by the manufacturer using the charging pattern prescribed for normal charging; and
- (c) in an ambient temperature of between 20 °C and 30 °C. This procedure shall exclude all types of special charge that could be automatically or manually initiated, e.g. equalisation or servicing charges. The manufacturer shall declare that no special charge procedure has occurred during the test.

3.2.2.4.2. End-of-charge criteria

Status: Point in time view as at 16/12/2013.

Changes to legislation: There are currently no known outstanding effects for the Commission Delegated Regulation (EU) No 134/2014. (See end of Document for details)

The end-of-charge criteria shall correspond to a charging time of twelve hours, except where the standard instrumentation indicates clearly that the electrical energy/power storage device is not yet fully charged, in which case:

Equation Ap3-1:

the maximum time is = $\frac{3 \times \text{claimed battery capacity (Wh)}}{\text{mains power supply (W)}}$

3.2.3. Test procedure

3.2.3.1. The vehicle shall be started up by the means provided for normal use by the driver. The first cycle starts on the initiation of the vehicle start-up procedure.

3.2.3.2. The test procedures defined in either point 3.2.3.2.1. or 3.2.3.2.2. may be used.

3.2.3.2.1. Sampling shall begin (BS) before or at the initiation of the vehicle start-up procedure and end on conclusion of the final idling period in the applicable type I driving cycle (end of sampling (ES)).

3.2.3.2.2. Sampling shall begin (BS) before or at the initiation of the vehicle start-up procedure and continue over a number of repeat test cycles. It shall end on conclusion of the applicable type I driving cycle during which the battery reached the minimum state of charge in accordance with the following procedure (end of sampling (ES)):

3.2.3.2.2. The electricity balance Q (Ah) is measured over each combined cycle, using the procedure in Appendix 3.2., and used to determine when the battery's minimum state of charge has been reached.

3.2.3.2.2. The battery's minimum state of charge is considered to have been reached in combined cycle N if the electricity balance Q measured during combined cycle N + 1 is not more than a 3 percent discharge, expressed as a percentage of the nominal capacity of the battery (in Ah) in its maximum state of charge, as declared by the manufacturer. At the manufacturer's request, additional test cycles may be run and their results included in the calculations in points 3.2.3.5. and 3.4., provided that the electricity balance for each additional test cycle shows less discharge of the battery than over the previous cycle.

3.2.3.2.2. Between each pair of cycles, a hot soak period of up to ten minutes is allowed. The powertrain shall be switched off during this period.

3.2.3.3. The vehicle shall be driven according to the applicable type I driving cycle and gear-shifting prescriptions in Annex II.

3.2.3.4. The tailpipe emissions of the vehicle shall be analysed according to the provisions of Annex II in force at the time of approval of the vehicle.

3.2.3.5. The CO₂ emission and fuel consumption results from the test cycle(s) for Condition A shall be recorded (respectively m₁ (g) and c₁ (l)). Parameters m₁ and c₁ shall be the sums of the results of the N combined cycles run.

Equation Ap3-2:

$$m_1 = \sum_{i=1}^N m_i$$

Equation Ap3-3:

$$c_1 = \sum_{i=1}^N c_i$$

Status: Point in time view as at 16/12/2013.

Changes to legislation: There are currently no known outstanding effects for the Commission Delegated Regulation (EU) No 134/2014. (See end of Document for details)

3.2.4. Within the 30 minutes after the conclusion of the cycle, the electrical energy/power storage device shall be charged according to point 3.2.2.4. The energy measurement equipment, placed between the mains socket and the vehicle charger, measures the charge energy e_1 (Wh) delivered from the mains.

3.2.5. The electric energy consumption for Condition A shall be e_1 (Wh).

3.3. Condition B

3.3.1. Conditioning of the vehicle

3.3.1.1. The electrical energy/power storage device of the vehicle shall be discharged in accordance with point 3.2.1.1. At the manufacturer's request, a conditioning in accordance with point 3.2.2.1. may be carried out before electrical energy/power storage discharge.

3.3.1.2. Before testing, the vehicle shall be kept in a room in which the temperature remains relatively constant between 293,2 K and 303,2 K (20 °C and 30 °C). This conditioning shall be carried out for at least six hours and continue until the temperatures of the engine oil and coolant, if any, are within ± 2 K of the temperature of the room.

3.3.2. Test procedure

3.3.2.1. The vehicle shall be started up by the means provided for normal use by the driver. The first cycle starts on the initiation of the vehicle start-up procedure.

3.3.2.2. Sampling shall begin (BS) before or at the initiation of the vehicle start-up procedure and end on conclusion of the final idling period in the applicable type I driving cycle (end of sampling (ES)).

3.3.2.3. The vehicle shall be driven using the applicable type I driving cycle and gear-shifting prescriptions set out in Appendix 6 to Annex II.

3.3.2.4. The tailpipe emissions of the vehicle shall be analysed according to the provisions of Annex II.

3.3.2.5. The test results for Condition B shall be recorded (m_2 (g) and c_2 (l) respectively).

3.3.3. Within 30 minutes of the end of the cycle, the electrical energy/power storage device shall be charged in accordance with point 3.2.2.4.

The energy measurement equipment, placed between the mains socket and the vehicle charger, measures the energy charge e_2 (Wh) delivered from the mains.

3.3.4. The electrical energy/power storage device of the vehicle shall be discharged in accordance with point 3.2.1.1.

3.3.5. Within 30 minutes of the discharge, the electrical energy/power storage device shall be charged in accordance with point 3.2.2.4.

The energy measurement equipment, placed between the mains socket and the vehicle charger, measures the energy charge e_3 (Wh) delivered from the mains.

3.3.6. The electric energy consumption e_4 (Wh) for Condition B is:

Equation Ap3-4:

$$e_4 = e_2 - e_3$$

Status: Point in time view as at 16/12/2013.

Changes to legislation: There are currently no known outstanding effects for the Commission Delegated Regulation (EU) No 134/2014. (See end of Document for details)

3.4. Test results

3.4.1. The CO₂ values shall be:

Equation Ap3-5:

$$M_1 = m_1 / D_{\text{test1}}$$

and

Equation Ap3-6:

$$M_2 = m_2 / D_{\text{test2}}$$

(mg/km)

where:

D_{test1} and D_{test2} = the actual distances driven in the tests performed under Conditions A (point 3.2.) and B (point 3.3.) respectively, and

m_1 and m_2 = test results determined in points 3.2.3.5. and 3.3.2.5. respectively.

3.4.2.1. For testing in accordance with point 3.2.3.2.1:

The weighted CO₂ values shall be calculated as follows:

Equation Ap3-7:

$$M = (D_e \times M_1 + D_{\text{av}} \times M_2) / (D_e + D_{\text{av}})$$

where:

M = mass emission of CO₂ in grams per kilometre,

M_1 = mass emission of CO₂ in grams per kilometre with a fully charged electrical energy/power storage device,

M_2 = mass emission of CO₂ in grams per kilometre with an electrical energy/power storage device in minimum state of charge (maximum discharge of capacity),

D_e = electric range of the vehicle determined according to the procedure described in Appendix 3.3., where the manufacturer shall provide the means for performing the measurement with the vehicle running in pure electric operating state,

D_{av} = average distance between two battery recharges, D_{av} =:

- 4 km for an L-category vehicle with an engine capacity of < 150 cm³;
- 6 km for an L-category vehicle with an engine capacity of ≥ 150 cm³ and $v_{\text{max}} < 130$ km/h;
- 10 km for an L-category vehicle with an engine capacity of ≥ 150 cm³ and $v_{\text{max}} \geq 130$ km/h.

3.4.2.2. For testing in accordance with point 3.2.3.2.2.:

Equation Ap3-8:

$$M = (D_{\text{ovc}} \times M_1 + D_{\text{av}} \times M_2) / (D_{\text{ovc}} + D_{\text{av}})$$

where:

M = mass emission of CO₂ in grams per kilometre,

Status: Point in time view as at 16/12/2013.

Changes to legislation: There are currently no known outstanding effects for the Commission Delegated Regulation (EU) No 134/2014. (See end of Document for details)

M_1	= mass emission of CO ₂ in grams per kilometre with a fully charged electrical energy/power storage device,
M_2	= mass emission of CO ₂ in grams per kilometre with an electrical energy/power storage device in minimum state of charge (maximum discharge of capacity),
D_{ovc}	= OVC range according to the procedure described in Appendix 3.3.,
D_{av}	= average distance between two battery recharges, D_{av} =:
	— 4 km for an L-category vehicle with an engine capacity of < 150 cm ³ ;
	— 6 km for an L-category vehicle with an engine capacity of ≥ 150 cm ³ and $v_{max} < 130$ km/h;
	— 10 km for an L-category vehicle with an engine capacity of ≥ 150 cm ³ and $v_{max} ≥ 130$ km/h.

3.4.3. The fuel consumption values shall be:

Equation Ap3-9:

$$C_1 = 100 \times c_1 / D_{test1}$$

Equation Ap3-10:

$$C_2 = 100 \times c_2 / D_{test2}$$

(l/100 km) for liquid fuels and (kg/100) km for gaseous fuel

where:

D_{test1} and D_{test2}	= the actual distances driven in the tests performed under Conditions A (point 3.2.) and B (point 3.3.) respectively, and
c_1 and c_2	= test results determined in points 3.2.3.8. and 3.3.2.5. respectively.

3.4.4. The weighted fuel consumption values shall be calculated as follows:

3.4.4.1. For testing in accordance with point 3.2.3.2.1.:

Equation Ap3-11:

$$C = (D_e \times C_1 + D_{av} \times C_2) / (D_e + D_{av})$$

where:

C	= fuel consumption in l/100 km,
C_1	= fuel consumption in l/100 km with a fully charged electrical energy/power storage device,
C_2	= fuel consumption in l/100 km with an electrical energy/power storage device in minimum state of charge (maximum discharge of capacity),
D_e	= electric range of the vehicle determined according to the procedure described in Appendix 3.3., where the manufacturer shall provide the means for performing the measurement with the vehicle running in pure electric operating state,
D_{av}	= average distance between two battery recharges, D_{av} =:
	— 4 km for an L-category vehicle with an engine capacity of < 150 cm ³ ;
	— 6 km for an L-category vehicle with an engine capacity of ≥ 150 cm ³ and $v_{max} < 130$ km/h;

Status: Point in time view as at 16/12/2013.

Changes to legislation: There are currently no known outstanding effects for the Commission Delegated Regulation (EU) No 134/2014. (See end of Document for details)

- 10 km for an L-category vehicle with an engine capacity of $\geq 150 \text{ cm}^3$ and $v_{\text{max}} \geq 130 \text{ km/h}$.

3.4.4.2. For testing in accordance with point 3.2.3.2.2.:

Equation Ap3-12:

$$C = (D_{\text{OVC}} \times C_1 + D_{\text{av}} \times C_2) / (D_{\text{OVC}} + D_{\text{av}})$$

where:

- C = fuel consumption in l/100 km,
- C₁ = fuel consumption in l/100 km with a fully charged electrical energy/power storage device,
- C₂ = fuel consumption in l/100 km with an electrical energy/power storage device in minimum state of charge (maximum discharge of capacity),
- D_{OVC} = OVC range according to the procedure described in Appendix 3.3.
- D_{av} = average distance between two battery recharges, D_{av} =:
 - 4 km for an L-category vehicle with an engine capacity of $< 150 \text{ cm}^3$;
 - 6 km for an L-category vehicle with an engine capacity of $\geq 150 \text{ cm}^3$ and $v_{\text{max}} < 130 \text{ km/h}$;
 - 10 km for an L-category vehicle with an engine capacity of $\geq 150 \text{ cm}^3$ and $v_{\text{max}} \geq 130 \text{ km/h}$.

3.4.5. The electric energy consumption values shall be:

Equation Ap3-13:

$$E_1 = e_1 / D_{\text{test1}}$$

and

Equation Ap3-14:

$$E_4 = e_4 / D_{\text{test2}}$$

(Wh/km)

with D_{test1} and D_{test2} the actual distances driven in the tests performed under Conditions A (point 3.2.) and B (point 3.3.) respectively, and e₁ and e₄ determined in points 3.2.5. and 3.3.6. respectively.

3.4.6. The weighted electric energy consumption values shall be calculated as follows:

3.4.6.1. For testing in accordance with point 3.2.3.2.1.:

Equation Ap3-15:

$$E = (D_e \times E_1 + D_{\text{av}} \times E_4) / (D_e + D_{\text{av}})$$

where:

- E = electric consumption Wh/km,
- E₁ = electric consumption Wh/km with a fully charged electrical energy/power storage device,
- E₄ = electric consumption Wh/km with an electrical energy/power storage device in minimum state of charge (maximum discharge of capacity),
- D_e = electric range of the vehicle determined according to the procedure described in Appendix 3.3., where the manufacturer shall provide the

Status: Point in time view as at 16/12/2013.

Changes to legislation: There are currently no known outstanding effects for the Commission Delegated Regulation (EU) No 134/2014. (See end of Document for details)

- means for performing the measurement with the vehicle running in pure electric operating state,
- D_{av} = average distance between two battery recharges, D_{av} =:
- 4 km for an L-category vehicle with an engine capacity of $< 150 \text{ cm}^3$;
 - 6 km for an L-category vehicle with an engine capacity of $\geq 150 \text{ cm}^3$ and $v_{max} < 130 \text{ km/h}$;
 - 10 km for an L-category vehicle with an engine capacity of $\geq 150 \text{ cm}^3$ and $v_{max} \geq 130 \text{ km/h}$.

3.4.6.2. For testing in accordance with point 3.2.3.2.2.:

Equation Ap3-16:

$$E = (D_{ovc} \times E_1 + D_{av} \times E_4) / (D_{ovc} + D_{av})$$

where:

- E = electric consumption Wh/km,
- E_1 = electric consumption Wh/km with a fully charged electrical energy/power storage device,
- E_4 = electric consumption Wh/km with an electrical energy/power storage device in minimum state of charge (maximum discharge of capacity),
- D_{ovc} = OVC range according to the procedure described in Appendix 3.3.
- D_{av} = average distance between two battery recharges, D_{av} =:
- 4 km for an L-category vehicle with an engine capacity of $< 150 \text{ cm}^3$;
 - 6 km for an L-category vehicle with an engine capacity of $\geq 150 \text{ cm}^3$ and $v_{max} < 130 \text{ km/h}$;
 - 10 km for an L-category vehicle with an engine capacity of $\geq 150 \text{ cm}^3$ and $v_{max} \geq 130 \text{ km/h}$.

4. Externally chargeable (OVC HEV) with an operating mode switch

4.1. Two tests shall be performed under the following conditions:

4.1.1. Condition A: test carried out with a fully charged electrical energy/power storage device.

4.1.2. Condition B: test carried out with an electrical energy/power storage device in minimum state of charge (maximum discharge of capacity).

4.1.3. The operating mode switch shall be positioned in accordance with Table Ap11-2, point 3.2.1.3. of Appendix 11 of Annex II.

4.2. Condition A

4.2.1. If the electric range of the vehicle, as measured in accordance with Appendix 3.3., is higher than one complete cycle, the type I test for electric energy measurement may be carried out in pure electric mode at the request of the manufacturer after agreement of the technical service and to the satisfaction of the approval authority. In this case, the values of M_1 and C_1 in point 4.4. shall be taken as equal to 0.

4.2.2. The procedure shall start with the discharge of the electrical energy/power storage device of the vehicle as described in point 4.2.2.1.

Status: Point in time view as at 16/12/2013.

Changes to legislation: There are currently no known outstanding effects for the Commission Delegated Regulation (EU) No 134/2014. (See end of Document for details)

- 4.2.2.1. The electrical energy/power storage device of the vehicle is discharged while driving with the switch in pure electric position (on the test track, on a chassis dynamometer, etc.) at a steady speed of 70 percent \pm 5 percent of the maximum design vehicle speed in pure electric mode, determined in accordance with the test procedure to measure the maximum design vehicle speed set out in Appendix 1 to Annex X.

Discharge shall stop in any of the following conditions:

- when the vehicle is unable to run at 65 percent of the maximum thirty minutes speed,
- when the standard on-board instrumentation indicates that the vehicle should be stopped,
- after 100 km.

If the vehicle is not equipped with a pure electric mode, the electrical energy/power storage device shall be discharged by driving the vehicle (on the test track, on a chassis dynamometer, etc.) at any of the following conditions:

- at a steady speed of 50 km/h until the fuel-consuming engine starts up,
- if a vehicle cannot reach a steady speed of 50 km/h without the fuel-consuming engine starting up, the speed shall be reduced until it can run at a lower steady speed at which the fuel-consuming engine does not start up for a defined time or distance (to be determined by the technical service and the manufacturer to the satisfaction of the approval authority),
- in accordance with the manufacturer's recommendation.

The fuel-consuming engine shall be stopped within ten seconds of being automatically started. By means of derogation if the manufacturer can prove to the technical service to the satisfaction of the approval authority that the vehicle is physically not capable of achieving the thirty minutes speed the maximum fifteen minute speed may be used instead.

4.2.3. Conditioning of the vehicle

- 4.2.3.1. The test vehicle shall be preconditioned by conducting the applicable type I test cycle in combination with the applicable gear-shifting prescriptions in point 4.5.5. of Annex II.

- 4.2.3.2. After this preconditioning and before testing, the vehicle shall be kept in a room in which the temperature remains relatively constant between 293,2 K and 303,2 K (20 °C and 30 °C). This conditioning shall be carried out for at least six hours and continue until the temperatures of the engine oil and coolant, if any, are within \pm 2 K of the temperature of the room, and the electrical energy/power storage device is fully charged as a result of the charging prescribed in point 4.2.3.3.

- 4.2.3.3. During soak, the electrical energy/power storage device shall be charged using the normal overnight charging procedure as defined in point 3.2.2.4.

4.2.4. Test procedure

- 4.2.4.1. The vehicle shall be started up by the means provided for normal use by the driver. The first cycle starts on the initiation of the vehicle start-up procedure.

- 4.2.4.2. The test procedures defined in either point 4.2.4.2.1. or 4.2.4.2.2. may be used.

Status: Point in time view as at 16/12/2013.

Changes to legislation: There are currently no known outstanding effects for the Commission Delegated Regulation (EU) No 134/2014. (See end of Document for details)

- 4.2.4.2.1. Sampling shall begin (BS) before or at the initiation of the vehicle start-up procedure and end on conclusion of the final idling period in the applicable type I driving cycle (end of sampling (ES)).
- 4.2.4.2.2. Sampling shall begin (BS) before or at the initiation of the vehicle start-up procedure and continue over a number of repeat test cycles. It shall end on conclusion of the applicable type I driving cycle during which the battery reached the minimum state of charge in accordance with the following procedure (end of sampling (ES)):
- 4.2.4.2.2.1. The electricity balance Q (Ah) is measured over each combined cycle, using the procedure in Appendix 3.2., and used to determine when the battery's minimum state of charge has been reached.
- 4.2.4.2.2.2. The battery's minimum state of charge is considered to have been reached in combined cycle N if the electricity balance measured during combined cycle N + 1 is not more than a 3 percent discharge, expressed as a percentage of the nominal capacity of the battery (in Ah) in its maximum state of charge, as declared by the manufacturer. At the manufacturer's request, additional test cycles may be run and their results included in the calculations in points 4.2.4.5. and 4.4., provided that the electricity balance for each additional test cycle shows less discharge of the battery than over the previous cycle.
- 4.2.4.2.2.3. Between each pair of cycles, a hot soak period of up to ten minutes is allowed. The powertrain shall be switched off during this period.
- 4.2.4.3. The vehicle shall be driven using the applicable driving cycle and gear-shifting prescriptions as defined in appendix 9 to Annex II.
- 4.2.4.4. The exhaust gases shall be analysed according to Annex II in force at the time of approval of the vehicle.
- 4.2.4.5. The CO₂ emission and fuel consumption results on the test cycle for Condition A shall be recorded (m_1 (g) and c_1 (l) respectively). In the case of testing in accordance with point 4.2.4.2.1., m_1 and c_1 are the results of the single combined cycle run. In the case of testing in accordance with point 4.2.4.2.2., m_1 and c_1 are the sums of the results of the N combined cycles run:
- Equation Ap3-17:*
- $$m_1 = \sum_1^N m_i$$
- Equation Ap3-18:*
- $$c_1 = \sum_1^N c_i$$
- 4.2.5. Within 30 minutes of the end of the cycle, the electrical energy/power storage device shall be charged in accordance with point 3.2.2.4.

The energy measurement equipment, placed between the mains socket and the vehicle charger, shall measure the energy charge e_1 (Wh) delivered from the mains.

- 4.2.6. The electric energy consumption for Condition A shall be e_1 (Wh).

- 4.3. Condition B

Status: Point in time view as at 16/12/2013.

Changes to legislation: There are currently no known outstanding effects for the Commission Delegated Regulation (EU) No 134/2014. (See end of Document for details)

4.3.1. Conditioning of the vehicle

4.3.1.1. The electrical energy/power storage device of the vehicle shall be discharged in accordance with point 4.2.2.1.

At the manufacturer's request, conditioning in accordance with point 4.2.3.1. may be carried out before electrical energy/power storage discharge.

4.3.1.2. Before testing, the vehicle shall be kept in a room in which the temperature shall remain relatively constant between 293,2 K and 303,2 K (20 °C and 30 °C). This conditioning shall be carried out for at least six hours and continue until the temperatures of the engine oil and coolant, if any, are within ± 2 K of the temperature of the room.

4.3.2. Test procedure

4.3.2.1. The vehicle shall be started up by the means provided for normal use by the driver. The first cycle starts on the initiation of the vehicle start-up procedure.

4.3.2.2. Sampling shall begin (BS) before or at the initiation of the vehicle start-up procedure and end on conclusion of the final idling period in the applicable type I driving cycle (end of sampling (ES)).

4.3.2.3. The vehicle shall be driven using the applicable driving cycle and gear-shifting prescriptions as defined in Annex II.

4.3.2.4. The exhaust gases shall be analysed in accordance with the provisions of Annex II in force at the time of approval of the vehicle.

4.3.2.5. The CO₂ emission and fuel consumption results on the test cycle(s) for Condition B shall be recorded (m_2 (g) and c_2 (l) respectively).

4.3.3. Within 30 minutes of the end of the cycle, the electrical energy/power storage device shall be charged in accordance with point 3.2.2.4.

The energy measurement equipment, placed between the mains socket and the vehicle charger, shall measure the energy charge e_2 (Wh) delivered from the mains.

4.3.4. The electrical energy/power storage device of the vehicle shall be discharged in accordance with point 4.2.2.1.

4.3.5. Within 30 minutes of the discharge, the electrical energy/power storage device shall be charged in accordance with point 3.2.2.4. The energy measurement equipment, placed between the mains socket and the vehicle charger, shall measure the energy charge e_3 (Wh) delivered from the mains.

4.3.6. The electric energy consumption e_4 (Wh) for Condition B shall be:

Equation Ap3-19:

$$e_4 = e_2 - e_3$$

4.4. Test results

4.4.1. The CO₂ values shall be:

Equation Ap3-20:

$$M_1 = m_1 / D_{\text{test1}}$$

Status: Point in time view as at 16/12/2013.

Changes to legislation: There are currently no known outstanding effects for the Commission Delegated Regulation (EU) No 134/2014. (See end of Document for details)

(mg/km) and

Equation Ap3-21:

$$M_2 = m_2 / D_{\text{test2}}$$

(mg/km)

where:

D_{test1} and D_{test2} = the actual distances driven in the tests performed under Conditions A (point 4.2.) and B (point 4.3.) respectively, and

m_1 and m_2 = test results determined in points 4.2.4.5. and 4.3.2.5. respectively

4.4.2. The weighted CO₂ values shall be calculated as follows:

4.4.2.1. For testing in accordance with point 4.2.4.2.1.:

Equation Ap3-22:

$$M = (D_e \times M_1 + D_{\text{av}} \times M_2) / (D_e + D_{\text{av}})$$

where:

- | | | |
|-----------------|---|--|
| M | = | mass emission of CO ₂ in grams per kilometre, |
| M_1 | = | mass emission of CO ₂ in grams per kilometre with a fully charged electrical energy/power storage device, |
| M_2 | = | mass emission of CO ₂ in grams per kilometre with an electrical energy/power storage device in minimum state of charge (maximum discharge of capacity), |
| D_e | = | electric range of the vehicle determined according to the procedure described in Appendix 3.3., where the manufacturer shall provide the means for performing the measurement with the vehicle running in pure electric operating state, |
| D_{av} | = | average distance between two battery recharges, D_{av} =: |
| | — | 4 km for an L-category vehicle with an engine capacity of < 150 cm ³ ; |
| | — | 6 km for an L-category vehicle with an engine capacity of ≥ 150 cm ³ and $v_{\text{max}} < 130$ km/h; |
| | — | 10 km for an L-category vehicle with an engine capacity of ≥ 150 cm ³ and $v_{\text{max}} \geq 130$ km/h. |

4.4.2.2. For testing in accordance with point 4.2.4.2.2.:

Equation Ap3-23:

$$M = (D_{\text{ove}} \times M_1 + D_{\text{av}} \times M_2) / (D_{\text{ove}} + D_{\text{av}})$$

where:

- | | | |
|-------|---|--|
| M | = | mass emission of CO ₂ in grams per kilometre, |
| M_1 | = | mass emission of CO ₂ in grams per kilometre with a fully charged electrical energy/power storage device, |

Status: Point in time view as at 16/12/2013.

Changes to legislation: There are currently no known outstanding effects for the Commission Delegated Regulation (EU) No 134/2014. (See end of Document for details)

M_2	=	mass emission of CO ₂ in grams per kilometre with an electrical energy/power storage device in minimum state of charge (maximum discharge of capacity),
D_{ovc}	=	OVC range according to the procedure described in Appendix 3.3.
D_{av}	=	average distance between two battery recharges, D_{av} =:
	—	4 km for an L-category vehicle with an engine capacity of < 150 cm ³ ;
	—	6 km for an L-category vehicle with an engine capacity of ≥ 150 cm ³ and v_{max} < 130 km/h;
	—	10 km for an L-category vehicle with an engine capacity of ≥ 150 cm ³ and v_{max} ≥ 130 km/h.

4.4.3. The fuel consumption values shall be:

Equation Ap3-24:

$$C_1 = 100 \times c_1 / D_{test1}$$

and

Equation Ap3-25:

$$C_2 = 100 \times c_2 / D_{test2}$$

(l/100 km)

where:

D_{test1} and D_{test2} = the actual distances driven in the tests performed under Conditions A (point 4.2.) and B (point 4.3.) respectively.

c_1 and c_2 = test results determined in points 4.2.4.5. and 4.3.2.5. respectively.

4.4.4. The weighted fuel consumption values shall be calculated as follows:

4.4.4.1. For testing in accordance with point 4.2.4.2.1.:

Equation Ap3-26:

$$C = (D_e \times C_1 + D_{av} \times C_2) / (D_e + D_{av})$$

where:

C	=	fuel consumption in l/100 km,
C_1	=	fuel consumption in l/100 km with a fully charged electrical energy/power storage device,
C_2	=	fuel consumption in l/100 km with an electrical energy/power storage device in minimum state of charge (maximum discharge of capacity),
D_e	=	electric range of the vehicle determined according to the procedure described in Appendix 3.3., where the manufacturer shall provide the means for performing the measurement with the vehicle running in pure electric operating state,
D_{av}	=	average distance between two battery recharges, D_{av} =:

Status: Point in time view as at 16/12/2013.

Changes to legislation: There are currently no known outstanding effects for the Commission Delegated Regulation (EU) No 134/2014. (See end of Document for details)

- 4 km for an L-category vehicle with an engine capacity of < 150 cm³;
- 6 km for an L-category vehicle with an engine capacity of ≥ 150 cm³ and v_{max} < 130 km/h;
- 10 km for an L-category vehicle with an engine capacity of ≥ 150 cm³ and v_{max} ≥ 130 km/h.

4.4.4.2. For testing in accordance with point 4.2.4.2.2.:

Equation Ap3-27:

$$C = (D_{ovc} \times C_1 + D_{av} \times C_2) / (D_{ovc} + D_{av})$$

where:

- C = fuel consumption in l/100 km,
- C₁ = fuel consumption in l/100 km with a fully charged electrical energy/power storage device,
- C₂ = fuel consumption in l/100 km with an electrical energy/power storage device in minimum state of charge (maximum discharge of capacity),
- D_{ovc} = OVC range according to the procedure described in Appendix 3.3.,
- D_{av} = average distance between two battery recharges, D_{av} =:
 - 4 km for an L-category vehicle with an engine capacity of < 150 cm³;
 - 6 km for an L-category vehicle with an engine capacity of ≥ 150 cm³ and v_{max} < 130 km/h;
 - 10 km for an L-category vehicle with an engine capacity of ≥ 150 cm³ and v_{max} ≥ 130 km/h.

4.4.5. The electric energy consumption values shall be:

Equation Ap3-28:

$$E_1 = e_1 / D_{test1}$$

and

Equation Ap3-29:

$$E_4 = e_4 / D_{test2}$$

(Wh/km)

where:

- D_{test1} and D_{test2} = the actual distances driven in the tests performed under Conditions A (point 4.2.) and B (point 4.3.) respectively, and
- e₁ and e₄ = test results determined in points 4.2.6. and 4.3.6. respectively.

4.4.6. The weighted electric energy consumption values shall be calculated as follows:

Status: Point in time view as at 16/12/2013.

Changes to legislation: There are currently no known outstanding effects for the Commission Delegated Regulation (EU) No 134/2014. (See end of Document for details)

4.4.6.1. For testing in accordance with point 4.2.4.2.1.:

Equation Ap3-30:

$$E = (D_e \times E_1 + D_{av} \times E_4) / (D_e + D_{av})$$

where:

- E = electric consumption Wh/km,
- E₁ = electric consumption Wh/km with a fully charged electrical energy/power storage device,
- E₄ = electric consumption Wh/km with an electrical energy/power storage device in minimum state of charge (maximum discharge of capacity),
- D_e = electric range of the vehicle determined according to the procedure described in Appendix 3.3., where the manufacturer shall provide the means for performing the measurement with the vehicle running in pure electric operating state,
- D_{av} = average distance between two battery recharges, D_{av} =:
 - 4 km for an L-category vehicle with an engine capacity of < 150 cm³;
 - 6 km for an L-category vehicle with an engine capacity of ≥ 150 cm³ and v_{max} < 130 km/h;
 - 10 km for an L-category vehicle with an engine capacity of ≥ 150 cm³ and v_{max} ≥ 130 km/h.

4.4.6.2. For testing in accordance with point 4.2.4.2.2.:

Equation Ap3-31:

$$E = (D_{ovc} \times E_1 + D_{av} \times E_4) / (D_{ovc} + D_{av})$$

where:

- E = electric consumption Wh/km,
- E₁ = electric consumption Wh/km with a fully charged electrical energy/ power storage device,
- E₄ = electric consumption Wh/km with an electrical energy/power storage device in minimum state of charge (maximum discharge of capacity),
- D_{ovc} = OVC range according to the procedure described in Appendix 3.3.,
- D_{av} = average distance between two battery recharges, D_{av} =:
 - 4 km for an L-category vehicle with an engine capacity of < 150 cm³;
 - 6 km for an L-category vehicle with an engine capacity of ≥ 150 cm³ and v_{max} < 130 km/h;
 - 10 km for an L-category vehicle with an engine capacity of ≥ 150 cm³ and v_{max} ≥ 130 km/h.

Status: Point in time view as at 16/12/2013.

Changes to legislation: There are currently no known outstanding effects for the Commission Delegated Regulation (EU) No 134/2014. (See end of Document for details)

5. Not externally chargeable hybrid electric vehicle (NOVC HEV) without an operating mode switch

5.1. The test vehicle shall be preconditioned by conducting the applicable type I test cycle in combination with the applicable gear-shifting prescriptions in point 4.5.5. of Annex II.

5.1.1. Carbon dioxide (CO₂) emissions and fuel consumption shall be determined separately for parts 1, 2 and 3, if applicable, of the applicable driving cycle in Appendix 6 to Annex II.

5.2. For preconditioning, at least two consecutive complete driving cycles shall be carried out without intermediate soak, using the applicable driving cycle and gear-shifting prescriptions set out in point 4.5.5. of Annex II.

5.3. Test results

5.3.1. The test results (fuel consumption C (l/100 km for liquid fuels or kg/100 km for gaseous fuels) and CO₂-emission M (g/km)) of this test shall be corrected in line with the energy balance ΔE_{batt} of the battery of the vehicle.

The corrected values C₀ (l/100 km or kg/100 km) and M₀ (g/km) shall correspond to a zero energy balance ($\Delta E_{\text{batt}} = 0$) and shall be calculated using a correction coefficient determined by the manufacturer for storage systems other than electric batteries as follows: ΔE_{batt} shall represent $\Delta E_{\text{storage}}$, the energy balance of the electric energy storage device.

5.3.1.1. The electricity balance Q (Ah), measured using the procedure in Appendix 3.2. to this Appendix, shall be used as a measure of the difference between the vehicle battery's energy content at the end of the cycle and that at the beginning of the cycle. The electricity balance is to be determined separately for the individual parts 1, 2 and 3, if applicable, of the type I test cycle in Annex II.

5.3.2. the uncorrected measured values C and M may be taken as the test results under the following conditions:

(a) the manufacturer can demonstrate to the satisfaction of the approval authority that there is no relation between the energy balance and fuel consumption,

(b) ΔE_{batt} always corresponds to a battery charging,

(c) ΔE_{batt} always corresponds to a battery discharging and ΔE_{batt} is within 1 percent of the energy content of the consumed fuel (i.e. the total fuel consumption over one cycle).

The change in battery energy content ΔE_{batt} shall be calculated from the measured electricity balance Q as follows:

Equation Ap3-32:

$$\Delta E_{\text{batt}} = \Delta \text{SOC}(\%) \times E_{\text{TEbatt}} \cong 0,0036 \times |\Delta \text{Ah}| \times V_{\text{batt}} = 0,0036 \times Q \times V_{\text{batt}} \text{ (MJ)}$$

where:

E_{TEbatt} = the total energy storage capacity of the battery (MJ) and

V_{batt} = the nominal battery voltage (V).

5.3.3. Fuel consumption correction coefficient (K_{fuel}) defined by the manufacturer

Status: Point in time view as at 16/12/2013.

Changes to legislation: There are currently no known outstanding effects for the Commission Delegated Regulation (EU) No 134/2014. (See end of Document for details)

5.3.3.1. The fuel consumption correction coefficient (K_{fuel}) shall be determined from a set of n measurements, which shall contain at least one measurement with $Q_i < 0$ and at least one with $Q_j > 0$.

If this second measurement cannot be taken on the applicable test type I driving cycle used in this test, the technical service shall judge the statistical significance of the extrapolation necessary to determine the fuel consumption value at $\Delta E_{\text{batt}} = 0$ to the satisfaction of the approval authority.

5.3.3.2. The fuel consumption correction coefficient (K_{fuel}) shall be defined as:

Equation Ap3-33:

$$K_{\text{fuel}} = \frac{(n \times \sum Q_i C_i - \sum Q_i \times \sum C_i)}{(n \times \sum Q_i^2 - (\sum Q_i)^2)}$$

(l/100 km/Ah)

where:

- C_i = fuel consumption measured during i -th manufacturer's test (l/100 km or kg/100km),
 Q_i = electricity balance measured during i -th manufacturer's test (Ah),
 n = number of data.

The fuel consumption correction coefficient shall be rounded to four significant figures (e.g. 0.xxxx or xx.xx). The technical service shall judge the statistical significance of the fuel consumption correction coefficient to the satisfaction of the approval authority.

5.3.3.3. Separate fuel consumption correction coefficients shall be determined for the fuel consumption values measured over parts 1, 2 and 3, if applicable, of the type I test cycle in Annex II.

5.3.4. Fuel consumption at zero battery energy balance (C_0)

5.3.4.1. Fuel consumption C_0 at $\Delta E_{\text{batt}} = 0$ is determined by the following equation:

Equation Ap3-34:

$$C_0 = C - K_{\text{fuel}} \times Q$$

(l/100 km or kg/100 km)

where:

- C = fuel consumption measured during test (l/100 km for liquid fuels and kg/100 km for gaseous fuels),
 Q = electricity balance measured during test (Ah).

5.3.4.2. Fuel consumption at zero battery energy balance shall be determined separately for the fuel consumption values measured over parts 1, 2 or 3, if applicable, of the type I test cycle in Annex II.

5.3.5. CO₂-emission correction coefficient (K_{CO_2}) defined by the manufacturer

5.3.5.1. The CO₂-emission correction coefficient (K_{CO_2}) shall be determined as follows from a set of n measurements, which shall contain at least one measurement with $Q_i < 0$ and at least one with $Q_j > 0$.

Status: Point in time view as at 16/12/2013.

Changes to legislation: There are currently no known outstanding effects for the Commission Delegated Regulation (EU) No 134/2014. (See end of Document for details)

If this second measurement cannot be taken on the driving cycle used in this test, the technical service shall judge the statistical significance of the extrapolation necessary to determine the CO₂-emission value at $\Delta E_{\text{batt}} = 0$ to the satisfaction of the approval authority.

5.3.5.2. The CO₂-emission correction coefficient (K_{CO_2}) is defined as:

Equation Ap3-35:

$$K_{\text{CO}_2} = \frac{(n \times \sum Q_i M_i - \sum Q_i \times \sum M_i)}{(n \times \sum Q_i^2 - (\sum Q_i)^2)}$$

(g/km/Ah)

where:

M_i = CO₂-emission measured during i-th manufacturer's test (g/km),
 Q_i = electricity balance during i-th manufacturer's test (Ah),
 n = number of data.

The CO₂-emission correction coefficient shall be rounded to four significant figures (e.g. 0.xxxx or xx.xx). The technical service shall judge the statistical significance of the CO₂-emission correction coefficient to the satisfaction of the approval authority.

5.3.5.3. Separate CO₂-emission correction coefficients shall be determined for the fuel consumption values measured over parts 1, 2 and 3, if applicable, of the type driving cycle in Annex II.

5.3.6. CO₂-emission at zero battery energy balance (M_0)

5.3.6.1. The CO₂-emission M_0 at $\Delta E_{\text{batt}} = 0$ is determined by the following equation:

Equation Ap3-36:

$$M_0 = M - K_{\text{CO}_2} \times Q$$

(g/km)

where:

C = fuel consumption measured during test (l/100 km for liquid fuels and kg/100 km for gaseous fuels),
 Q = electricity balance measured during test (Ah).

5.3.6.2. CO₂ emissions at zero battery energy balance shall be determined separately for the CO₂ emission values measured over part 1, 2 and 3, if applicable, of the type I test cycle set out in Appendix 6 to Annex II.

6. Not Externally Chargeable (not OVC HEV) with an operating mode switch

6.1. These vehicles shall be tested in hybrid mode in accordance with Appendix 1, using the applicable driving cycle and gear-shifting prescriptions in point 4.5.5. of Annex II. If several hybrid modes are available, the test shall be carried out in the mode that is automatically set after the ignition key is turned on (normal mode).

6.1.1. Carbon dioxide (CO₂) emissions and fuel consumption shall be determined separately for parts 1, 2 and 3 of the type I test cycle in Annex II.

6.2. For preconditioning, at least two consecutive complete driving cycles shall be carried out without intermediate soak, using the applicable type I test cycle and gear-shifting prescriptions in Annex II.

Status: Point in time view as at 16/12/2013.

Changes to legislation: There are currently no known outstanding effects for the Commission Delegated Regulation (EU) No 134/2014. (See end of Document for details)

6.3. Test results

6.3.1. The fuel consumption C (l/100 km) and CO₂-emission M (g/km) results of this test shall be corrected in line with the energy balance ΔE_{batt} of the battery of the vehicle.

The corrected values (C_0 (l/100 km for liquid fuels or kg/100 km for gaseous fuels) and M_0 (g/km)) shall correspond to a zero energy balance ($\Delta E_{\text{batt}} = 0$), and are to be calculated using a correction coefficient determined by the manufacturer as defined in 6.3.3 and 6.3.5.

For storage systems other than electric batteries, ΔE_{batt} shall represent $\Delta E_{\text{storage}}$, the energy balance of the electric energy storage device.

6.3.1.1. The electricity balance Q (Ah), measured using the procedure in Appendix 3.2., shall be used as a measure of the difference between the vehicle battery's energy content at the end of the cycle and that at the beginning of the cycle. The electricity balance is to be determined separately for parts 1, 2 and 3 of the applicable type I test cycle set out in Annex II.

6.3.2. The uncorrected measured values C and M may be taken as the test results under the following conditions:

- (a) the manufacturer can prove that there is no relation between the energy balance and fuel consumption,
- (b) ΔE_{batt} always corresponds to a battery charging,
- (c) ΔE_{batt} always corresponds to a battery discharging and ΔE_{batt} is within 1 percent of the energy content of the consumed fuel (i.e. the total fuel consumption over one cycle).

The change in battery energy content ΔE_{batt} can be calculated from the measured electricity balance Q as follows:

Equation Ap3-37:

$$\Delta E_{\text{batt}} = \Delta \text{SOC}(\%) \times E_{\text{TEbatt}} \cong 0,0036 \times |\Delta \text{Ah}| \times V_{\text{batt}} = 0,0036 \times Q \times V_{\text{batt}} \text{ (MJ)}$$

where:

- E_{TEbatt} = the total energy storage capacity of the battery (MJ),
and
- V_{batt} = the nominal battery voltage(V).

6.3.3. Fuel consumption correction coefficient (K_{fuel}) defined by the manufacturer

6.3.3.1. The fuel consumption correction coefficient (K_{fuel}) shall be determined from a set of n measurements, which shall contain at least one measurement with $Q_i < 0$ and at least one with $Q_j > 0$.

If this second measurement cannot be taken on the driving cycle used in this test, the technical service shall judge the statistical significance of the extrapolation necessary to determine the fuel consumption value at $\Delta E_{\text{batt}} = 0$ to the satisfaction of the approval authority.

6.3.3.2. The fuel consumption correction coefficient (K_{fuel}) shall be defined as:

Equation Ap3-38:

$$K_{\text{fuel}} = \frac{(n \times \sum Q_i C_i - \sum Q_i \times \sum C_i) / (n \times \sum Q_i^2 - \sum Q_i^2)}{\text{in (l/100 km/Ah)}}$$

Status: Point in time view as at 16/12/2013.

Changes to legislation: There are currently no known outstanding effects for the Commission Delegated Regulation (EU) No 134/2014. (See end of Document for details)

where:

- C_i = fuel consumption measured during i-th manufacturer's test (l/100 km for liquid fuels and kg/100 km for gaseous fuels)
 Q_i = electricity balance measured during i-th manufacturer's test (Ah)
 n = number of data

The fuel consumption correction coefficient shall be rounded to four significant figures (e.g. 0.xxxx or xx.xx). The statistical significance of the fuel consumption correction coefficient shall be judged by the technical service to the satisfaction of the approval authority.

6.3.3.3. Separate fuel consumption correction coefficients shall be determined for the fuel consumption values measured over parts 1, 2 and 3, if applicable, for the type I test cycle set out in Annex II.

6.3.4. Fuel consumption at zero battery energy balance (C_0)

6.3.4.1. The fuel consumption C_0 at $\Delta E_{\text{batt}} = 0$ is determined by the following equation:

Equation AP-39:

$$C_0 = C - K_{\text{fuel}} \times Q$$

(in l/100 km for liquid fuels and kg/100 km for gaseous fuels)

where:

- C = fuel consumption measured during test (in l/100 km or kg/100 km)
 Q = electricity balance measured during test (Ah)

6.3.4.2. Fuel consumption at zero battery energy balance shall be determined separately for the fuel consumption values measured over parts 1, 2 and 3, if applicable, for the type I test cycle set out in Annex II.

6.3.5. CO_2 -emission correction coefficient (K_{CO_2}) defined by the manufacturer

6.3.5.1. The CO_2 -emission correction coefficient (K_{CO_2}) shall be determined as follows from a set of n measurements. This set shall contain at least one measurement with $Q_i < 0$ and one with $Q_j > 0$.

If this second measurement cannot be taken on the type I test cycle used in this test, the technical service shall judge the statistical significance of the extrapolation necessary to determine the CO_2 -emission value at $\Delta E_{\text{batt}} = 0$ to the satisfaction of the approval authority.

6.3.5.2. The CO_2 -emission correction coefficient (K_{CO_2}) shall be defined as:

Equation AP-40:

$$K_{\text{CO}_2} = (n \times \sum Q_i M_i - \sum Q_i \times \sum M_i) / (n \times \sum Q_i^2 - (\sum Q_i)^2)$$

in (g/km/Ah)

where:

- M_i = CO_2 -emission measured during i-th manufacturer's test (g/km)
 Q_i = electricity balance during i-th manufacturer's test (Ah)
 N = number of data

Status: Point in time view as at 16/12/2013.

Changes to legislation: There are currently no known outstanding effects for the Commission Delegated Regulation (EU) No 134/2014. (See end of Document for details)

The CO₂-emission correction coefficient shall be rounded to four significant figures (e.g. 0.xxxx or xx.xx). The statistical significance of the CO₂-emission correction coefficient shall be judged by the technical service to the satisfaction of the approval authority.

6.3.5.3. Separate CO₂-emission correction coefficients shall be determined for the fuel consumption values measured over parts 1, 2 and 3 of the applicable type I test cycle.

6.3.6. CO₂ emission at zero battery energy balance (M₀)

6.3.6.1. The CO₂ emission M₀ at ΔE_{batt} = 0 is determined by the following equation:

Equation AP-41:

$$M_0 = M - K_{CO_2} \times Q$$

in (g/km)

where:

C : fuel consumption measured during test (l/100 km)

Q : electricity balance measured during test (Ah)

6.3.6.2. CO₂ emission at zero battery energy balance shall be determined separately for the CO₂-emission values measured over parts 1, 2 and 3, if applicable, for the type I test cycle set out in Annex II.

Status: Point in time view as at 16/12/2013.

Changes to legislation: There are currently no known outstanding effects for the Commission Delegated Regulation (EU) No 134/2014. (See end of Document for details)

Appendix 3.1

Electrical energy/power storage device State Of Charge (SOC) profile for an Externally chargeable Hybrid Electric Vehicle (OVC HEV) in a type VII test

1. State of charge (SOC) profile for OVC HEV type VII test

The SOC profiles for OVC-HEVs tested under Conditions A and B of the test type VII shall be:

1.1. Condition A:

Figure Ap3.1-1

Condition A of the type VII test

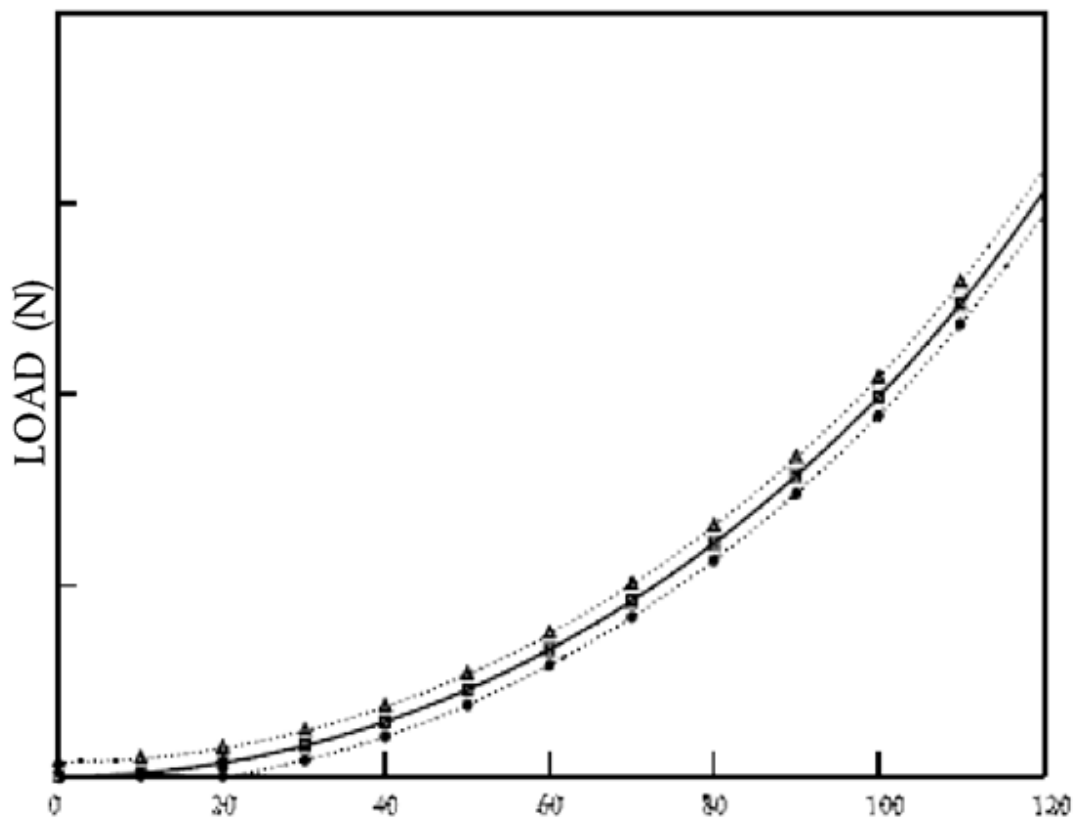

1.2. Condition B:

Figure Ap3.1-2

Status: Point in time view as at 16/12/2013.

Changes to legislation: There are currently no known outstanding effects for the Commission Delegated Regulation (EU) No 134/2014. (See end of Document for details)

Condition B of the type VII test

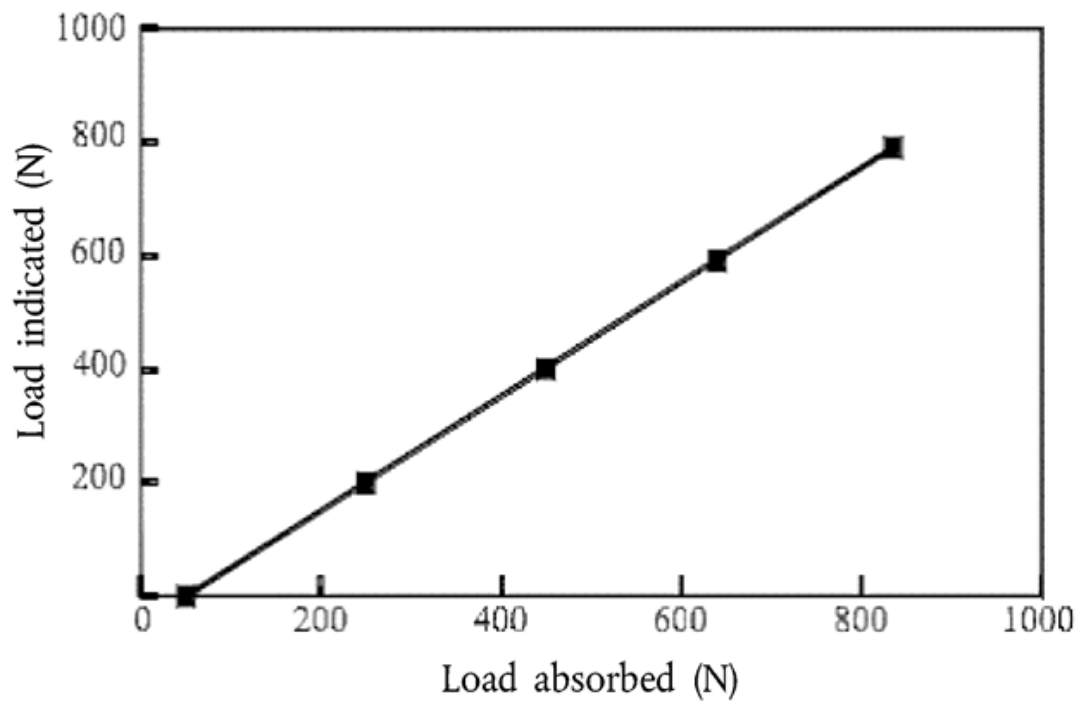

Status: Point in time view as at 16/12/2013.

Changes to legislation: There are currently no known outstanding effects for the Commission Delegated Regulation (EU) No 134/2014. (See end of Document for details)

Appendix 3.2

Method for measuring the electricity balance of the battery of OVC and NOVC HEV

1. Introduction

- 1.1. This Appendix sets out the method and required instrumentation for measuring the electricity balance of Off-vehicle Charging Hybrid Electric Vehicles (OVC HEV) and Not-Off-vehicle Charging Hybrid Electric Vehicles (NOVC HEV). Measurement of the electricity balance is necessary:
- (a) to determine when the battery's minimum state of charge has been reached during the test procedure in points 3.3. and 4.3. of Appendix 3, and
 - (b) to adjust the fuel consumption and CO₂-emissions measurements in line with the change in battery energy content during the test, using the method in points 5.3.1.1. and 6.3.1.1. of Appendix 3.
- 1.2. The method described in this Appendix shall be used by the manufacturer for taking the measurements to determine the correction factors K_{fuel} and K_{CO_2} , as defined in points 5.3.3.2., 5.3.5.2., 6.3.3.2., and 6.3.5.2. of Appendix 3.

The technical service shall check whether these measurements have been taken in accordance with the procedure described in this Appendix.

- 1.3. The method described in this Appendix shall be used by the technical service for measuring the electricity balance Q , as defined in the relevant points of Appendix 3.

2. Measurement equipment and instrumentation

- 2.1. During the tests described in points 3 to 6 of Appendix 3, the battery current shall be measured using a current transducer of the clamp-on or the closed type. The current transducer (i.e. the current sensor without data acquisition equipment) shall have a minimum accuracy of 0,5 percent of the measured value or 0,1 percent of the maximum value of the scale.

Original equipment manufacturer diagnostic testers are not to be used for the purpose of this test.

- 2.1.1. The current transducer shall be fitted on one of the wires directly connected to the battery. To make it easier to measure the battery current with external equipment, the manufacturer shall integrate appropriate, safe and accessible connection points in the vehicle. If that is not feasible, the manufacturer is obliged to support the technical service by providing the means to connect a current transducer to the wires connected to the battery as described in point 2.1.
- 2.1.2. The output of the current transducer shall be sampled with a minimum sample frequency of 5 Hz. The measured current shall be integrated over time, yielding the measured value of Q , expressed in Ampere hours (Ah).
- 2.1.3. The temperature at the location of the sensor shall be measured and sampled with the same sample frequency as the current, so that this value can be used for possible compensation of the drift of current transducers and, if applicable, the voltage transducer used to convert the output of the current transducer.
- 2.2. The technical service shall be provided with a list of the instrumentation (manufacturer, model number, serial number) used by the manufacturer for

Status: Point in time view as at 16/12/2013.

Changes to legislation: There are currently no known outstanding effects for the Commission Delegated Regulation (EU) No 134/2014. (See end of Document for details)

determining the correction factors K_{fuel} and K_{CO_2} set out in Appendix 3 and the last calibration dates of the instruments, where applicable.

3. **Measurement procedure**

- 3.1. Measurement of the battery current shall start at the beginning of the test and end immediately after the vehicle has driven the complete driving cycle.
- 3.2. Separate values of Q shall be logged over the parts (cold/warm or phase 1 and, if applicable, phases 2 and 3) of the type I test cycle set out in Annex II.

Status: Point in time view as at 16/12/2013.

Changes to legislation: There are currently no known outstanding effects for the Commission Delegated Regulation (EU) No 134/2014. (See end of Document for details)

Appendix 3.3

Method of measuring the electric range of vehicles powered by an electric powertrain only or by a hybrid electric powertrain and the OVC range of vehicles powered by a hybrid electric powertrain

1. Measurement of the electric range

The following test method set out in point 4 shall be used to measure the electric range, expressed in km, of vehicles powered by an electric power train only or the electric range and OVC range of vehicles powered by a hybrid electric powertrain with off-vehicle charging (OVC HEV) as defined in Appendix 3.

2. Parameters, units and accuracy of measurements

Parameters, units and accuracy of measurements shall be as follows:

TABLE AP3.3.-1

Parameters, units and accuracy of measurements

Parameter	Unit	Accuracy	Resolution
Time	s	± 0,1 s	0,1 s
Distance	m	± 0,1 percent	1 m
Temperature	K	± 1 K	1 K
Speed	km/h	± 1 percent	0,2 km/h
Mass	kg	± 0,5 percent	1 kg

3. Test conditions

3.1. Condition of the vehicle

- 3.1.1. The vehicle tyres shall be inflated to the pressure specified by the vehicle manufacturer when the tyres are at the ambient temperature.
- 3.1.2. The viscosity of the oils for the mechanical moving parts shall conform to the vehicle manufacturer's specifications.
- 3.1.3. The lighting and signalling and auxiliary devices shall be off, except those required for the testing and usual daytime operation of the vehicle.
- 3.1.4. All energy storage systems for other than traction purposes (electric, hydraulic, pneumatic, etc.) shall be charged to their maximum level as specified by the manufacturer.
- 3.1.5. If the batteries are operated above the ambient temperature, the operator shall follow the procedure recommended by the vehicle manufacturer in order to keep the battery temperature in the normal operating range. The manufacturer shall be in a position to attest that the thermal management system of the battery is neither disabled nor reduced.

3.1.6. The vehicle shall have travelled at least 300 km in the seven days before the test with the batteries installed for the test.

3.2. Climatic conditions

For testing performed outdoors, the ambient temperature shall be between 278,2 K and 305,2 K (5 °C and 32 °C).

The indoor testing shall be performed at a temperature of between 275,2 K and 303,2 K (2 °C and 30 °C).

4. **Operation modes**

The test method includes the following steps:

- (a) initial charge of the battery;
- (b) application of the cycle and measurement of the electric range.

If the vehicle shall move between the steps, it shall be pushed to the next test area (without regenerative recharging).

4.1. Initial charge of the battery

Charging the battery consists of the following procedure:

4.1.1. The 'initial charge' of the battery means the first charge of the battery, on reception of the vehicle. Where several combined tests or measurements are carried out consecutively, the first charge shall be an 'initial charge' and the subsequent charges may follow the 'normal overnight charge' procedure set out in 3.2.2.4. of Appendix 3.

4.1.2. Discharge of the battery

4.1.2.1. For pure electric vehicles:

4.1.2.1.1. The procedure starts with the discharge of the battery of the vehicle while driving (on the test track, on a chassis dynamometer, etc.) at a steady speed of 70 percent \pm 5 percent of the maximum design vehicle speed, which is to be determined according to the test procedure in Appendix 1 to Annex X.

4.1.2.1.2. Discharging shall stop under any of the following conditions:

- (a) when the vehicle is unable to run at 65 percent of the maximum thirty minutes speed;
- (b) when the standard on-board instrumentation indicates that the vehicle should be stopped;
- (c) after 100 km.

By means of derogation if the manufacturer can prove to the technical service to the satisfaction of the approval authority that the vehicle is physically not capable of achieving the thirty minutes speed the maximum fifteen minute speed may be used instead.

4.1.2.2. For externally chargeable hybrid electric vehicles (OVC HEV) without an operating mode switch as defined in Appendix 3:

Status: Point in time view as at 16/12/2013.

Changes to legislation: There are currently no known outstanding effects for the Commission Delegated Regulation (EU) No 134/2014. (See end of Document for details)

4.1.2.2.1. The manufacturer shall provide the means for taking the measurement with the vehicle running in pure electric operating state.

4.1.2.2.2. The procedure shall start with the discharge of the electrical energy/power storage device of the vehicle while driving (on the test track, on a chassis dynamometer, etc.) in any of the following conditions:

- at a steady speed of 50 km/h until the fuel-consuming engine of the HEV starts up;
- if a vehicle cannot reach a steady speed of 50 km/h without the fuel-consuming engine starting up, the speed shall be reduced until it can run at a lower steady speed at which the fuel-consuming engine does not start up for a defined time or distance (to be determined by the technical service and the manufacturer to the satisfaction of the approval authority);
- in accordance with the manufacturer's recommendation.

The fuel-consuming engine shall be stopped within ten seconds of being automatically started.

4.1.2.3. For externally chargeable hybrid electric vehicles (OVC HEV) with an operating mode switch as defined in Appendix 3:

4.1.2.3.1. If the mode switch does not have a pure electric position, the manufacturer shall provide the means for taking the measurement with the vehicle running in pure electric operating state.

4.1.2.3.2. The procedure shall start with the discharge of the electrical energy/power storage device of the vehicle while driving with the switch in pure electric position (on the test track, on a chassis dynamometer, etc.) at a steady speed of 70 percent \pm 5 percent of the maximum design vehicle speed of the vehicle in pure electric mode, which is to be determined according to the test procedure in Appendix 1 to Annex X.

4.1.2.3.3. Discharging shall stop in any of the following conditions:

- when the vehicle is unable to run at 65 percent of the maximum thirty minutes speed;
- when the standard on-board instrumentation indicates that the vehicle should be stopped;
- after 100 km.

By means of derogation if the manufacturer can prove to the technical service to the satisfaction of the approval authority that the vehicle is physically not capable of achieving the thirty minutes speed the maximum fifteen minute speed may be used instead.

4.1.2.3.4. If the vehicle is not equipped with a pure electric operating state, the electrical energy/power storage device shall be discharged by driving the vehicle (on the test track, on a chassis dynamometer, etc.):

- at a steady speed of 50 km/h until the fuel-consuming engine of the HEV starts up; or
- if a vehicle cannot reach a steady speed of 50 km/h without the fuel-consuming engine starting up, the speed shall be reduced until it can run at a lower steady speed at which the fuel-consuming engine does not start up for a defined time or distance (to be determined by the technical service and the manufacturer to the satisfaction of the approval authority); or
- in accordance with the manufacturer's recommendation.

The fuel-consuming engine shall be stopped within ten seconds of being automatically started.

4.1.3. Normal overnight charge

For a pure electric vehicle, the battery shall be charged according to the normal overnight charge procedure, as defined in point 2.4.1.2. of Appendix 2, for a period not exceeding twelve hours.

For an OVC HEV, the battery shall be charged according to the normal overnight charge procedure as described in point 3.2.2.4. of Appendix 3.

4.2. Application of the cycle and measurement of the range

4.2.1. For pure electric vehicles:

4.2.1.1. The test sequence set out in the Appendices shall be carried out on a chassis dynamometer adjusted as described in Annex II, until the test criteria are met.

4.2.1.2. The test criteria shall be deemed as having been met when the vehicle is unable to meet the target curve up to 50 km/h, or when the standard on-board instrumentation indicates that the vehicle should be stopped.

The vehicle shall then be slowed to 5 km/h without braking by releasing the accelerator pedal, and then stopped by braking.

4.2.1.3. At speeds of over 50 km/h, when the vehicle does not reach the acceleration or speed required for the test cycle, the accelerator pedal shall remain fully depressed, or the accelerator handle shall be turned fully, until the reference curve has been reached again.

4.2.1.4. Up to three interruptions, of no more than 15 minutes in total, are permitted between test sequences.

4.2.1.5. The distance covered in km (D_e) is the electric range of the electric vehicle. It shall be rounded to the nearest whole number.

4.2.2. For hybrid electric vehicles:

4.2.2.1.1. The applicable type I test cycle and accompanying gearshift arrangements, as set out in point 4.5.5. of Annex II shall be carried out on a chassis dynamometer adjusted as described in Annex II, until the test criteria are met.

4.2.2.1.2. To measure the electric range, the test criteria shall be deemed as having been met when the vehicle is unable to meet the target curve up to 50 km/h, or when the standard on-board instrumentation indicates that the vehicle should be stopped, or when the battery has reached its minimum state of charge. The vehicle shall then be slowed to 5 km/h without braking by releasing the accelerator pedal, and then stopped by braking.

4.2.2.1.3. At speeds of over 50 km/h, when the vehicle does not reach the acceleration or speed required for the test cycle, the accelerator pedal shall remain fully depressed until the reference curve has been reached again.

4.2.2.1.4. Up to three interruptions, of no more than 15 minutes in total, are permitted between test sequences.

4.2.2.1.5. The distance covered in km using the electrical motor only (D_e) is the electric range of the hybrid electric vehicle. It shall be rounded to the nearest whole number. Where

Status: Point in time view as at 16/12/2013.

Changes to legislation: There are currently no known outstanding effects for the Commission Delegated Regulation (EU) No 134/2014. (See end of Document for details)

the vehicle operates both in electric and in hybrid mode during the test, the periods of electric-only operation will be determined by measuring current to the injectors or ignition.

4.2.2.2. Determining the OVC range of a hybrid electric vehicle

4.2.2.2.1. The applicable type I test cycle and accompanying gearshift arrangements, as set out in point 4.4.5. of Annex II, shall be carried out on a chassis dynamometer adjusted as described in Annex II, until the test criteria are met.

4.2.2.2.2. To measure the OVC range D_{OVC} , the test criteria shall be deemed as having been met when the battery has reached its minimum state of charge according to the criteria in points 3.2.3.2.2.2. or 4.2.4.2.2.2. of Appendix 3. Driving shall be continued until the final idling period in the type I test cycle has been completed.

4.2.2.2.3. Up to three interruptions, of no more than fifteen minutes in total, are permitted between test sequences.

4.2.2.2.4. The total distance driven in km, rounded to the nearest whole number, shall be the OVC range of the hybrid electric vehicle.

4.2.2.3. At speeds of over 50 km/h, when the vehicle does not reach the acceleration or speed required for the test cycle, the accelerator pedal shall remain fully depressed, or the accelerator handle shall be turned fully, until the reference curve has been reached again.

4.2.2.4. Up to three interruptions, of no more than 15 minutes in total, are permitted between test sequences.

4.2.2.5. The distance covered in km (D_{OVC}) is the electric range of the hybrid electric vehicle. It shall be rounded to the nearest whole number.

ANNEX VIII

Test type VIII requirements: OBD environmental tests

1. Introduction

- 1.1. This Annex describes the procedure for type VIII testing on environmental on-board diagnostics (OBD). The procedure describes methods for checking the function of the OBD system on the vehicle by simulating failure of emission-relevant components in the powertrain management system and emission-control system.
- 1.2. The manufacturer shall make available the defective components or electrical devices to be used to simulate failures. When measured over the appropriate test type I cycle, such defective components or devices shall not cause the vehicle emissions to exceed by more than 20 percent the OBD thresholds set out in Annex VI(B) to Regulation (EU) No 168/2013.
- 1.3. When the vehicle is tested with the defective component or device fitted, the OBD system shall be approved if the malfunction indicator is activated. The system shall also be approved if the indicator is activated below the OBD thresholds.

2. OBD stage I and stage II

2.1. OBD stage I

The test procedures in this Annex shall be mandatory for L-category vehicles equipped with an OBD stage I system as referred to in Article 19 of and Annex IV to Regulation (EU) No 168/2013. This obligation concerns compliance with all provisions of this Annex except those relating to OBD stage II requirements referred to in point 2.2.

2.2. OBD stage II

- 2.2.1. An L-category vehicle may be equipped with an OBD stage II system at the choice of the manufacturer.
- 2.2.2. In such cases, the test procedures of this Annex may be used by the manufacturer to demonstrate voluntary compliance with OBD II requirements. This concerns in particular the applicable points listed in Table 7-1

Table 7-1

OBD stage II functions and associated requirements in points of this Annex and its Appendix 1

Topic	Points
Catalytic converter monitoring	8.3.1.1., 8.3.2.1.
EGR system monitoring	8.3.3.
Misfire detection	8.3.1.2.
NO _x after-treatment system monitoring	8.4.3.
Oxygen sensor deterioration	8.3.1.3.
Particulate filter	8.3.2.2.
Particulate matter (PM) monitoring	8.4.4.

Status: Point in time view as at 16/12/2013.

Changes to legislation: There are currently no known outstanding effects for the Commission Delegated Regulation (EU) No 134/2014. (See end of Document for details)

3. Description of tests

3.1. Test vehicle

3.1.1. The environmental OBD verification and demonstration tests shall be carried out on a test vehicle, that shall be properly maintained and used, dependent on the chosen durability test method set-out in Article 23(3) of Regulation (EU) No 168/2013 using the test procedures set-out in this Annex and in Annex II:

3.1.2. In case of applying the durability test procedure set out in Article 23(3a) or 23(3b) of Regulation (EU) No 168/2013 the test vehicles shall be equipped with the aged emission components used for durability tests as well as for the purposes of this Annex and the OBD environmental tests are to be finally verified and reported at the conclusion of the Type V durability testing;

3.1.3. In case the OBD demonstration test requires emission measurements, the type VIII test shall be carried out on the test vehicles used for the type V durability test in Annex V. Type VIII tests shall be finally verified and reported at the conclusion of the type V durability testing.

3.1.4. In case of applying the durability test procedure set out in Article 23(3c) of Regulation (EU) No 168/2013, the applicable deterioration factors set out in part B of Annex VII to that Regulation shall be multiplied with the emission test results.

3.2. The OBD system shall indicate the failure of an emission-related component or system when that failure results in emissions exceeding the OBD threshold in Part B of Annex VI to Regulation (EU) No 168/2013 or any powertrain fault that triggers an operation mode that significantly reduces torque in comparison with normal operation.

3.3. The test type I data in the test report referred to in Article 32(1) of Regulation (EU) No 168/2013, including the used dynamometer settings and applicable emission laboratory test cycle, shall be provided for reference.

3.4. The list with PCU/ECU malfunctions shall be provided pursuant to the requirements referred to in Number C11 of Annex II of Regulation (EU) No 168/2013 as follows:

3.4.1. for each malfunction that leads to the OBD emission thresholds set out in Part B of Annex VI to Regulation (EU) No 168/2013 in both non-defaulted and defaulted driving mode being exceeded. The emission laboratory test results shall be reported in those additional columns in the format of the information document referred to in Article 27(4) of Regulation (EU) No 168/2013;

3.4.2. for short descriptions of the methods used to simulate the emission-relevant malfunctions, as referred to in points 1.1., 8.3.1.1. and 8.3.1.3.

4. OBD environmental test procedure

4.1. The testing of OBD systems consists of the following phases:

4.1.1. Simulation of malfunction of a component of the powertrain management or emission-control system;

4.1.2. Preconditioning of the vehicle (in addition to the preconditioning specified in point 5.2.4. of Annex II) with a simulated malfunction that will lead to the OBD thresholds in Part B of Annex VI to Regulation (EU) No 168/2013 being exceeded;

Status: Point in time view as at 16/12/2013.

Changes to legislation: There are currently no known outstanding effects for the Commission Delegated Regulation (EU) No 134/2014. (See end of Document for details)

- 4.1.3. Driving the vehicle with a simulated malfunction over the applicable type I test cycle and measuring the emissions of the vehicle, as follows:
 - 4.1.3.1. For OVC vehicles, the pollutant emissions shall be measured under the same conditions as specified for Condition B of the type I test (points 3.3. and 4.3.).
 - 4.1.3.2. For NOVC vehicles, the pollutant emissions shall be measured under the same conditions as in the type I test;
- 4.1.4. Determining whether the OBD system reacts to the simulated malfunction and alerts the vehicle driver to it in an appropriate manner.
- 4.2. Alternatively, at the request of the manufacturer, malfunction of one or more components may be electronically simulated in accordance with the requirements laid down in point 8.
- 4.3. Manufacturers may request that monitoring take place outside the type I test cycle if it can be demonstrated to the approval authority that the monitoring conditions of the type I test cycle would be restrictive when the vehicle is used in service.
- 4.4. For all demonstration testing, the Malfunction Indicator (MI) shall be activated before the end of the test cycle.

5. **Test vehicle and fuel**

5.1. Test vehicle

The test vehicles shall meet the requirements of point 2 of Annex VI.

- 5.2. The manufacturer shall set the system or component for which detection is to be demonstrated at or beyond the criteria limit prior to operating the vehicle over the emissions test cycle appropriate for the classification of the L-category vehicle. To determine correct functionality of the diagnostic system, the L-category vehicle shall then be operated over the appropriate type I test cycle according to its classification set out in point 4.3. of Annex II.

5.3. Test fuel

The appropriate reference fuel as described in Appendix 2 to Annex II shall be used for testing. For mono-fuelled and bi-fuelled gas vehicles, the fuel type for each failure mode to be tested may be selected by the approval authority from the reference fuels described in Appendix 2 to Annex II. The selected fuel type shall not be changed during any of the test phases. Where LPG or NG/biomethane for alternative fuel vehicles are used as a fuel, the engine may be started on petrol and switched to LPG or NG/biomethane (automatically and not by the driver) after a pre-determined period of time.

6. **Test temperature and pressure**

- 6.1. The test temperature and ambient pressure shall meet the requirements of the type I test as set out in Annex II.

7. **Test equipment**

7.1. Chassis dynamometer

The chassis dynamometer shall meet the requirements of Annex II.

8. **OBD environmental verification test procedures**

Status: Point in time view as at 16/12/2013.

Changes to legislation: There are currently no known outstanding effects for the Commission Delegated Regulation (EU) No 134/2014. (See end of Document for details)

- 8.1. The operating test cycle on the chassis dynamometer shall meet the requirements of Annex II.
- 8.2. Vehicle preconditioning
 - 8.2.1. According to the propulsion type and after introduction of one of the failure modes referred to in point 8.3., the vehicle shall be preconditioned by driving at least two consecutive appropriate type I tests. For vehicles equipped with a compression-ignition engine, additional preconditioning of two appropriate type I test cycles is permitted.
 - 8.2.2. At the request of the manufacturer, alternative preconditioning methods may be used.
- 8.3. Failure modes to be tested
 - 8.3.1. For positive-ignition propelled vehicles:
 - 8.3.1.1. Replacement of the catalytic converter type with a deteriorated or defective catalytic converter or electronic simulation of such a failure;
 - 8.3.1.2. Engine misfire conditions in line with those for misfire monitoring referred to in Annex II (C11) to Regulation (EU) No 168/2013;
 - 8.3.1.3. Replacement of the oxygen sensor with a deteriorated or defective sensor or electronic simulation of such a failure;
 - 8.3.1.4. Electrical disconnection of any other emission-related component connected to a powertrain control unit / engine control unit (if active on the selected fuel type);
 - 8.3.1.5. Electrical disconnection of the electronic evaporative purge control device (if equipped and if active on the selected fuel type). For this specific failure mode, the type I test need not be performed.
 - 8.3.2. For vehicles equipped with a compression-ignition engine:
 - 8.3.2.1. Replacement of the catalytic converter type, where fitted, with a deteriorated or defective catalytic converter or electronic simulation of such a failure;
 - 8.3.2.2. Total removal of the particulate filter, where fitted, or, where sensors are an integral part of the filter, a defective filter assembly;
 - 8.3.2.3. Electrical disconnection of any electronic fuel quantity and timing actuator in the fuelling system;
 - 8.3.2.4. Electrical disconnection of any other emission-related or functional safety-relevant component connected to any control unit of the powertrain, the propulsion units or the drive train;
 - 8.3.2.5. In meeting the requirements of points 8.3.2.3. and 8.3.2.4. and with the agreement of the approval authority, the manufacturer shall take appropriate steps to demonstrate that the OBD system will indicate a fault when disconnection occurs.
 - 8.3.3. The manufacturer shall demonstrate that malfunctions of the EGR flow and cooler, where fitted, are detected by the OBD system during its approval test.
 - 8.3.4. Any powertrain malfunction that triggers any operating mode which significantly reduces engine torque (i.e. by 10 % or more in normal operation) shall be detected and reported by the powertrain / engine control system.

Status: Point in time view as at 16/12/2013.

Changes to legislation: There are currently no known outstanding effects for the Commission Delegated Regulation (EU) No 134/2014. (See end of Document for details)

8.4. OBD system environmental verification tests

8.4.1. Vehicles fitted with positive-ignition engines:

- 8.4.1.1. After vehicle preconditioning in accordance with point 8.2., the test vehicle is driven over the appropriate type I test.

The malfunction indicator shall activate before the end of this test under any of the conditions given in points 8.4.1.2. to 8.4.1.6. The approval authority may substitute those conditions with others in accordance with point 8.4.1.6. However, the total number of failures simulated shall not exceed four for the purpose of type-approval.

For bi-fuelled gas vehicles, both fuel types shall be used within the maximum of four simulated failures at the discretion of the approval authority.

- 8.4.1.2. Replacement of a catalytic converter type with a deteriorated or defective catalytic converter or electronic simulation of a deteriorated or defective catalytic converter that results in emissions exceeding the THC OBD threshold, or if applicable the NMHC OBD threshold, in Part B of Annex VI to Regulation (EU) No 168/2013;
- 8.4.1.3. An induced misfire condition in line with those for misfire monitoring referred to in Annex II (C11) of Regulation (EU) No 168/2013 that results in emissions exceeding any of the OBD thresholds given in Part B of Annex VI to Regulation (EU) No 168/2013;
- 8.4.1.4. Replacement of an oxygen sensor with a deteriorated or defective oxygen sensor or electronic simulation of a deteriorated or defective oxygen sensor that results in emissions exceeding any of OBD thresholds in Part B of Annex VI to Regulation (EU) No 168/2013;
- 8.4.1.5. Electrical disconnection of the electronic evaporative purge control device (if equipped and if active on the selected fuel type);
- 8.4.1.6. Electrical disconnection of any other emission-related powertrain component connected to a powertrain control unit / engine control unit / drive train control unit that results in emissions exceeding any of the OBD thresholds in Part B of Annex VI to Regulation (EU) No 168/2013 or triggers an operation mode with significantly reduced torque as compared with normal operation.

8.4.2. Vehicles fitted with compression-ignition engines.

- 8.4.2.1. After vehicle preconditioning in accordance with point 8.2., the test vehicle is driven in the applicable type I test.

The malfunction indicator shall activate before the end of this test under any of the conditions in points 8.4.2.2. to 8.4.2.5. The approval authority may substitute those conditions by others in accordance with point 8.4.2.5. However, the total number of failures simulated shall not exceed four for the purposes of type-approval;

- 8.4.2.2. Replacement of a catalytic converter type, where fitted, with a deteriorated or defective catalytic converter or electronic simulation of a deteriorated or defective catalytic converter that results in emissions exceeding any of the OBD thresholds in Part B of Annex VI to Regulation (EU) No 168/2013;
- 8.4.2.3. Total removal of the particulate filter, where fitted, or replacement of the particulate filter with a defective particulate filter meeting the conditions laid down in point

Status: Point in time view as at 16/12/2013.

Changes to legislation: There are currently no known outstanding effects for the Commission Delegated Regulation (EU) No 134/2014. (See end of Document for details)

- 8.4.2.2. that results in emissions exceeding any of the OBD thresholds in Part B of Annex VI to Regulation (EU) No 168/2013.
- 8.4.2.4. With reference to point 8.3.2.5., disconnection of any electronic fuel quantity and timing actuator in the fuelling system that results in emissions exceeding any of the OBD thresholds in Part B of Annex VI to Regulation (EU) No 168/2013;
- 8.4.2.5. With reference to point 8.3.2.5., disconnection of any other powertrain component connected to a powertrain control unit / engine control / drive train control unit that results in emissions exceeding any of the OBD thresholds in Part B of Annex VI to Regulation (EU) No 168/2013 or that triggers an operation mode with a significantly reduced torque as compared with normal operation.
- 8.4.3. Replacement of the NO_x after-treatment system, where fitted, with a deteriorated or defective system or electronic simulation of such a failure.
- 8.4.4. Replacement of the particulate matter monitoring system, where fitted, with a deteriorated or defective system or electronic simulation of such a failure.

Status: Point in time view as at 16/12/2013.

Changes to legislation: There are currently no known outstanding effects for the Commission Delegated Regulation (EU) No 134/2014. (See end of Document for details)

ANNEX IX

Test type IX requirements: sound level

Appendix Number	Appendix title	Page
1	Sound level test requirements for powered cycles and two-wheel mopeds (category L1e)	247
2	Sound level test requirements for motorcycles (categories L3e and L4e)	258
3	Sound level test requirements for three-wheel mopeds, tricycles and quadricycles (categories L2e, L5e, L6e and L7e)	272
4	Test track specification	283

1. Introduction

This Annex describes the procedure for type IX testing, as referred to in Part A of Annex V to Regulation (EU) No 168/2013. It lays down specific provisions regarding permissible sound level test procedures for L-category vehicles.

2. Test procedure, measurements and results

- 2.1. Durability requirements of the noise abatement system shall be regarded as fulfilled if the vehicle complies with the requirements regarding conditioning of the test vehicle set-out in this Annex. In addition for vehicles equipped with silencers containing absorbent fibrous materials the relevant test procedure set-out in this Annex shall be conducted to demonstrate durability of the noise abatement system.
- 2.2. When the EU has acceded to:
 - UNECE regulation No 9: Uniform provisions concerning the approval of three-wheel vehicles or quadricycles with regard to noise;
 - UNECE regulation No 41⁽¹⁰⁾: Uniform provisions concerning the approval of motorcycles with regard to noise;
 - UNECE regulation No 63: Uniform provisions concerning the approval of mopeds with regard to noise;
 - UNECE regulation No 92: Uniform provisions concerning the approval of non-original replacement exhaust silencing systems (RESS) for motorcycles, mopeds and three-wheel vehicles;

the corresponding provisions of this Annex will become obsolete and vehicles of the applicable sub-category as listed in Table 8-1 shall comply with the requirements of the corresponding UNECE Regulation, including as regards sound limits:

Status: Point in time view as at 16/12/2013.

Changes to legislation: There are currently no known outstanding effects for the Commission Delegated Regulation (EU) No 134/2014. (See end of Document for details)

Table 8-1

L-category vehicle sub-categories and the applicable UNECE regulations regarding sound requirements

Vehicle (sub-)category	Vehicle category name	Applicable test procedure
L1e-A	Powered cycle	UNECE regulation No 63
L1e-B	Two-wheel moped $v_{\max} \leq 25$ km/h	
	Two-wheel moped $v_{\max} \leq 45$ km/h	
L2e	Three-wheel moped	UNECE regulation No 9
L3e	Two-wheel motorcycle Engine capacity ≤ 80 cm ³	UNECE regulation No 41
	Two-wheel motorcycle 80 cm ³ < Engine capacity \leq 175 cm ³	
	Two-wheel motorcycle Engine capacity > 175 cm ³	
L4e	Two-wheel motorcycle with side-car	
L5e-A	Tricycle	UNECE regulation No 9
L5e-B	Commercial tricycle	
L6e-A	Light quad	UNECE regulation No 63
L6e-B	Light mini-car	UNECE regulation No 9
L7e-A	On-road quad	
L7e-B	All-terrain vehicles	
L7e-C	Heavy mini-car	

3. Test vehicle

- 3.1. The test vehicles used for type VIII sound tests and in particular the noise abatement system and components shall be representative of the vehicle type with regard to the environmental performance produced in series and placed on the market. The test vehicle shall be properly maintained and used.
- 3.2. For vehicles propelled with compressed air, the sound shall be measured at highest nominal storage pressure of the compressed air + 0 / – 15 %.

Appendix 1

Sound level test requirements for powered cycles and two-wheel mopeds (category L1e)

1. Definitions

For the purposes of this Appendix:

- 1.1. ‘type of powered cycle or two-wheel moped as regards its sound level and exhaust system’ means L1e vehicles which do not differ in such essential respects as the following:
 - 1.1.1. type of engine (two- or four-stroke, reciprocating piston engine or rotary-piston engine, number and capacity of cylinders, number and type of carburettors or injection systems, arrangement of valves, maximum net power and corresponding speed). The cubic capacity of rotary-piston engines shall be deemed to be double the volume of the chamber;
 - 1.1.2. Drive train, in particular the number and ratios of the gears of the transmission and the final ratio;
 - 1.1.3. number, type and arrangement of exhaust systems;
- 1.2. ‘exhaust system’ or ‘silencer’ means a complete set of components necessary to limit the noise caused by a moped engine and its exhaust;
 - 1.2.1. ‘original exhaust system or silencer’ means a system of the type fitted to the vehicle at the time of the environmental performance type-approval or extension of type-approval. It may be that first fitted or a replacement;
 - 1.2.2. ‘non-original exhaust system or silencer’ means a system of a type other than that fitted to the vehicle at the time of the environmental performance type-approval or extension of type-approval. It may be used only as a replacement exhaust system or silencer;
- 1.3. ‘exhaust systems of differing types’ means systems which are fundamentally different in one of the following ways:
 - 1.3.1. systems comprising components bearing different factory markings or trademarks;
 - 1.3.2. systems comprising any component made of materials of different characteristics or comprising components which are of a different shape or size;
 - 1.3.3. systems in which the operating principles of at least one component are different;
 - 1.3.4. systems comprising components in different combinations;
- 1.4. ‘component of an exhaust system’ means one of the individual components which together form the exhaust system (such as exhaust pipe work, the silencer proper) and the air intake system (air filter), if any.

If the engine has to be equipped with an air intake system (air filter or intake noise absorber) in order to comply with the maximum permissible sound levels, the filter or

Status: Point in time view as at 16/12/2013.

Changes to legislation: There are currently no known outstanding effects for the Commission Delegated Regulation (EU) No 134/2014. (See end of Document for details)

the absorber shall be treated as components having the same importance as the exhaust system.

2. **Component type-approval in respect of the sound level and original exhaust system, as a separate technical unit, of a type of two-wheel moped**

2.1. Noise made by the two-wheel moped in motion (measuring conditions and method for testing of the vehicle during component type-approval)

2.1.1. Noise limits: see Part D of Annex VI to Regulation (EU) No 168/2013.

2.1.2. Measuring instruments

2.1.2.1. Acoustic measurements

The apparatus used for measuring the sound-level shall be a precision sound-level meter of the type described in International Electro-technical Commission (IEC) publication 179 *Precision sound-level meters*, second edition. Measurements shall be taken using the 'fast' response and the 'A' weighting also described in that publication.

At the beginning and end of each series of measurements, the sound-level meter shall be calibrated in accordance with the manufacturer's instructions, using an appropriate noise source (e.g. piston phone).

2.1.2.2. Speed measurements

Engine speed and moped speed on the test track shall be determined to within $\pm 3\%$.

2.1.3. Conditions of measurement

2.1.3.1. Condition of the moped

The combined weight of the rider and the test equipment used on the moped shall be between 70 kg and 90 kg. If necessary, weights shall be added to the moped to bring the combined weight up to at least 70 kg.

During the measurements, the moped shall be in running order (including coolant, oils, fuel, tools, spare wheel and rider).

Before the measurements are taken, the moped shall be brought to the normal operating temperature.

If the moped is fitted with fans with an automatic actuating mechanism, this system shall not be interfered with during the sound measurements. For mopeds with more than one driven wheel, only the drive provided for normal road operation may be used. Where a moped is fitted with a sidecar, this shall be removed for the purposes of the test.

2.1.3.2. Test site

The test site shall consist of a central acceleration section surrounded by a substantially flat test area. The acceleration section shall be flat; its surface shall be dry and such that surface noise remains low.

On the test site, the variations in the free sound field between the sound source at the centre of the acceleration section and the microphone shall not exceed 1 dB. This condition will be deemed to be met if there are no large objects which reflect sound, such as fences, rocks, bridges or buildings, within 50 m of the centre of the acceleration section. The surface covering of the test track shall conform to the requirements of Appendix 7.

Status: Point in time view as at 16/12/2013.

Changes to legislation: There are currently no known outstanding effects for the Commission Delegated Regulation (EU) No 134/2014. (See end of Document for details)

The microphone shall not be obstructed in any way which could affect the sound field, and no person may stand between the microphone and the sound source. The observer taking the measurements shall so position himself as not to affect the readings of the measuring instrument.

2.1.3.3. Miscellaneous

Measurements shall not be taken in poor atmospheric conditions. It shall be ensured that the results are not affected by gusts of wind.

For measurements, the A-weighted sound level of sound sources other than those of the vehicle to be tested and of wind effects shall be at least 10 dB(A) below the sound level produced by the vehicle. A suitable windscreen may be fitted to the microphone provided that account is taken of its effect on the microphone's sensitivity and directional characteristics.

If the difference between the ambient noise and the noise to be measured is between 10 and 16 dB(A), the test results shall be calculated by subtracting the appropriate correction from the readings on the sound-level meter, as in the following graph:

Figure Ap1-1

Difference between ambient noise and noise to be measured

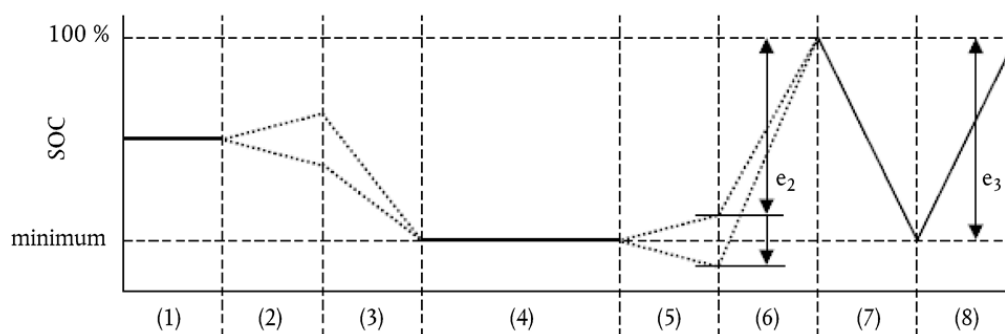

2.1.4. Method of measurement

2.1.4.1. Nature and number of measurements

The maximum sound level expressed in A-weighted decibels (dB(A)) shall be measured as the moped travels between lines AA' and BB' (Figure Ap1-2). The measurement will be invalid if an abnormal discrepancy is recorded between the peak value and the general noise level. At least two measurements shall be taken on each side of the moped.

2.1.4.2. Positioning of the microphone

The microphone shall be positioned $7,5 \text{ m} \pm 0,2 \text{ m}$ from the reference line CC' (Figure Ap1-2) of the track and $1,2 \text{ m} \pm 0,1 \text{ m}$ above ground level.

2.1.4.3. Conditions of operation

The moped shall approach line AA' at an initial steady speed as specified in point 2.1.4.3.1 and 2.1.4.3.2. When the front of the moped reaches line AA', the throttle shall be fully opened as quickly as practically possible and kept in that position until the rear of the moped reaches line BB'; the throttle shall then be returned as quickly as possible to the idle position.

For all measurements, the moped shall be ridden in a straight line over the acceleration section, keeping the median longitudinal plane of the moped as close as possible to line CC'.

Status: Point in time view as at 16/12/2013.

Changes to legislation: There are currently no known outstanding effects for the Commission Delegated Regulation (EU) No 134/2014. (See end of Document for details)

2.1.4.3.1. Approach speed

The moped shall approach line AA' at a steady speed of 30 km/h or at its top speed if this is less.

2.1.4.3.2. Selection of gear ratio

If the moped is fitted with a manual-shift gearbox, the highest gear which allows it to cross line AA' at a speed at least half the full-power engine speed shall be selected.

If the moped has an automatic transmission, it shall be ridden at the speeds indicated in 2.1.4.3.1.

2.1.5. Results (test report)

2.1.5.1. The test report according to the template referred to Article 32(1) to Regulation (EU) No 168/2013 drawn up for the purpose of issuing the document shall indicate any circumstances and factors affecting the measurements.

2.1.5.2. The measurements shall be rounded to the nearest decibel.

If the figure following the decimal point is between 0 and 4, the total is rounded down and if between 5 and 9, it is rounded up.

Only measurements which vary by 2,0 dB(A) or less in two consecutive tests on the same side of the moped shall be used.

2.1.5.3. To take account of inaccuracies, 1,0 dB(A) shall be deducted from each value obtained in accordance with point 2.1.5.2.

2.1.5.4. If the average of the four measurements does not exceed the maximum permissible level for the category of moped in question, the limits laid down in point 2.1.1 will be deemed as being complied with.

This average value shall be taken as the result of the test.

Figure Ap1-2

Status: Point in time view as at 16/12/2013.

Changes to legislation: There are currently no known outstanding effects for the Commission Delegated Regulation (EU) No 134/2014. (See end of Document for details)

Test for vehicle in motion

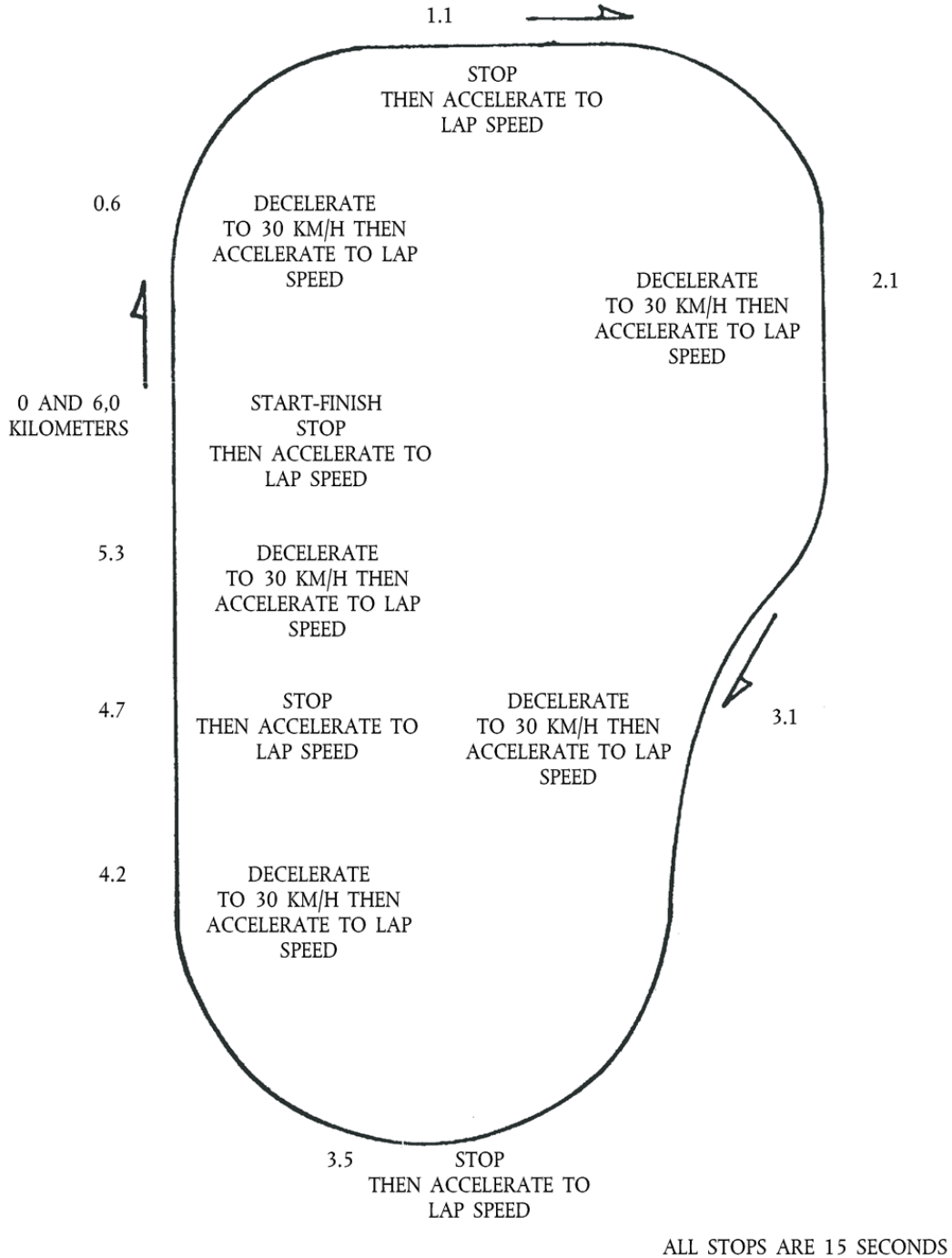
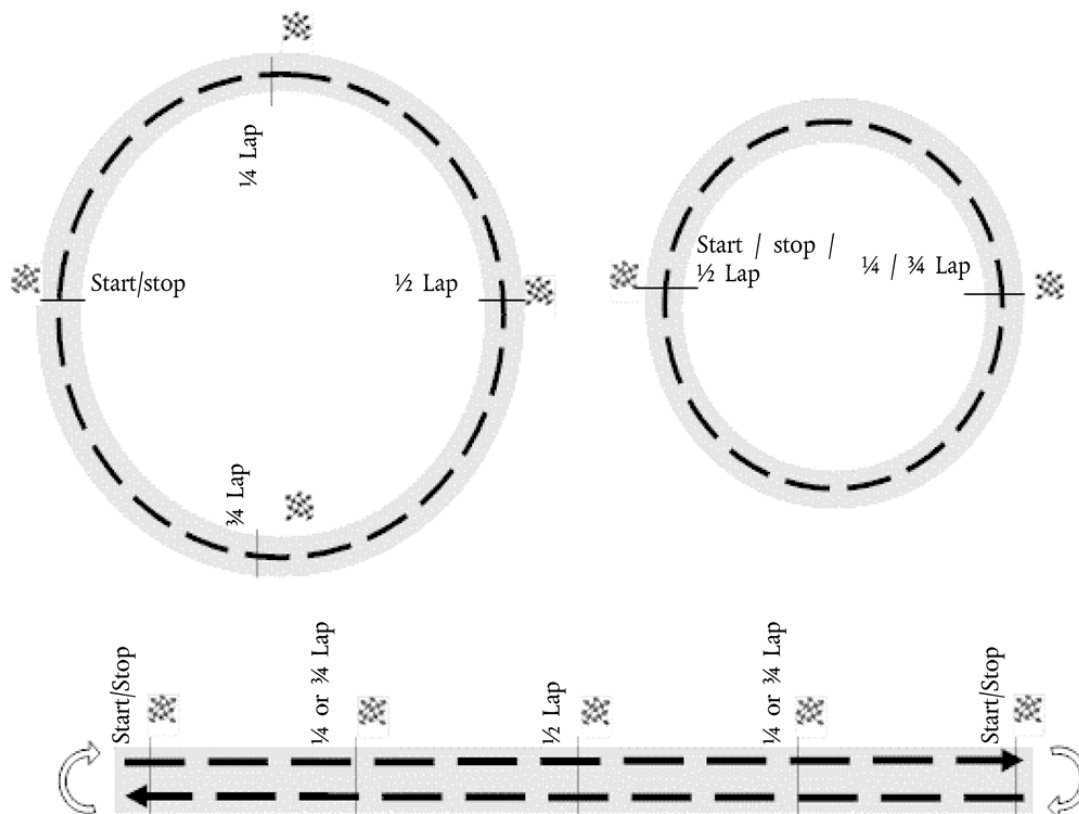

Figure Ap1-3

Status: Point in time view as at 16/12/2013.

Changes to legislation: There are currently no known outstanding effects for the Commission Delegated Regulation (EU) No 134/2014. (See end of Document for details)

Test for stationary vehicle



2.2. Noise from stationary moped (measuring conditions and method for testing of the vehicle in use)

2.2.1. Sound-pressure level in the immediate vicinity of the moped

In order to facilitate subsequent noise tests on mopeds in use, the sound-pressure level in the immediate vicinity of the exhaust-system outlet (silencer) shall be measured in accordance with the following requirements, the result being entered in the test report drawn up for the purpose of issuing the document according to the template referred to in Article 32(1) of Regulation (EU) No 168/2013.

2.2.2. Measuring instruments

A precision sound-level meter as defined in point 2.1.2.1 shall be used.

2.2.3. Conditions of measurement

2.2.3.1. Condition of the moped

Before the measurements are taken, the moped engine shall be brought to normal operating temperature. If the moped is fitted with fans with an automatic actuating mechanism, this system shall not be interfered with during the noise measurements.

During the measurements, the gearbox shall be in neutral gear. If it is impossible to disconnect the drive train, the driving wheel of the moped shall be allowed to rotate freely, e.g. by placing the vehicle on its centre stand.

2.2.3.2. Test site (Figure Ap1-2)

Status: Point in time view as at 16/12/2013.

Changes to legislation: There are currently no known outstanding effects for the Commission Delegated Regulation (EU) No 134/2014. (See end of Document for details)

Any area in which there are no significant acoustic disturbances may be used as a test site. Flat surfaces which are covered with concrete, asphalt or some other hard material and are highly reflective are suitable; surfaces consisting of earth which has been tamped down shall not be used. The test site shall be in the form of a rectangle the sides of which are at least 3 m from the outer edge of the moped (handlebars excluded). There shall be no significant obstacles, e.g. no persons other than the rider and the observer may stand within this rectangle.

The moped shall be positioned within the rectangle so that the microphone used for measurement is at least 1 m from any kerb.

2.2.3.3. Miscellaneous

Instrument readings caused by ambient noise and wind effects shall be at least 10,0 dB(A) lower than the noise levels to be measured. A suitable windshield may be fitted to the microphone provided that account is taken of its effect on the microphone's sensitivity.

2.2.4. Method of measurement

2.2.4.1. Nature and number of measurements

The maximum noise level expressed in A-weighted decibels (dB(A)) shall be measured during the period of operation laid down in point 2.2.4.3.

At least three measurements shall be taken at each measuring point.

2.2.4.2. Positioning of the microphone (Figure Ap1-3)

The microphone shall be positioned level with the exhaust outlet or 0,2 m above the surface of the track, whichever is higher. The microphone diaphragm shall face towards the exhaust outlet at a distance of 0,5 m from it. The axis of maximum sensitivity of the microphone shall be parallel to the surface of the track at an angle of $45^\circ \pm 10^\circ$ to the vertical plane of the direction of the exhaust emissions.

In relation to this vertical plane, the microphone shall be positioned on the side on which there is the maximum possible distance between the microphone and the outline of the moped (handlebars excluded).

If the exhaust system has more than one outlet at centres less than 0,3 m apart, the microphone shall face the outlet which is nearest the moped (handlebars excluded) or the outlet which is highest above the surface of the track. If the centres of the outlets are more than 0,3 m apart, separate measurements shall be taken for each of them; the highest figure recorded being taken as the test value.

2.2.4.3. Operating conditions

The engine speed shall be held steady at:

((S)/(2)) if S is more than 5 000 rpm; or

((3S)/(4)) if S is 5 000 rpm or less,

where 'S' is the engine speed at which maximum power is developed.

When a constant engine speed is reached, the throttle shall be returned swiftly to the idle position. The noise level shall be measured during an operating cycle consisting of a brief period of constant engine speed and throughout the deceleration period, the highest sound-level meter reading being taken as the test value.

2.2.5. Results (test report)

Status: Point in time view as at 16/12/2013.

Changes to legislation: There are currently no known outstanding effects for the Commission Delegated Regulation (EU) No 134/2014. (See end of Document for details)

2.2.5.1. The test report drawn up for the purpose of issuing the document according to the template referred to in Article 32(1) of Regulation (EU) No 168/2013 shall indicate all relevant data and particularly those used in measuring the noise of the stationary moped.

2.2.5.2. Values shall be read off the measuring instrument and rounded to the nearest decibel. Only measurements which vary by 2,0 dB(A) or less in three consecutive tests will be used.

2.2.5.3. The highest of the three measurements shall be taken as the test result.

2.3. Original exhaust system (silencer)

2.3.1. Requirements for silencers containing absorbent fibrous materials

2.3.1.1. Absorbent fibrous material shall be asbestos-free and may be used in the construction of silencers only if it is held securely in place throughout the service life of the silencer and meets the requirements of point 2.3.1.2, 2.3.1.3 or 2.3.1.4.

2.3.1.2. After removal of the fibrous material, the noise level shall comply with the requirements of point 2.1.1.

2.3.1.3. The absorbent fibrous material may not be placed in those parts of the silencer through which the exhaust gases pass and shall comply with the following requirements:

2.3.1.3.1. The material shall be heated at a temperature of $923,2 \pm 5$ K (650 ± 5 °C) for four hours in a furnace without reduction in the average length, diameter or bulk density of the fibre;

2.3.1.3.2. After being heated at $923,2 \pm 5$ K (650 ± 5 °C) for one hour in a furnace, at least 98 % of the material shall be retained in a sieve of nominal mesh size 250 µm complying with technical standard ISO 3310-1:2000 when tested in accordance with ISO standard 2559:2011;

2.3.1.3.3. The material shall lose no more than 10 % of its weight after being soaked for 24 hours at $362,2 \pm 5$ K (90 ± 5 °C) in a synthetic condensate of the following composition:

- 1 N hydrobromic acid (HBr): 10 ml
- 1 N sulphuric acid (H₂SO₄): 10 ml
- Distilled water to make up to 1 000 ml.

Note: The material shall be washed in distilled water and dried for one hour at 378,2 K (105 °C) before weighing.

2.3.1.4. Before the system is tested in accordance with point 2.1, it shall be put into normal working order by one of the following methods:

2.3.1.4.1. Conditioning by continuous road operation

2.3.1.4.1.1. The minimum distance to be travelled during conditioning shall be 2 000 km.

2.3.1.4.1.2. 30 ± 10 % of this conditioning cycle shall consist of town driving and the remainder of long-distance runs; the continuous road cycle may be replaced by a corresponding test-track programme.

2.3.1.4.1.3. The two types of driving shall be alternated at least six times.

Status: Point in time view as at 16/12/2013.

Changes to legislation: There are currently no known outstanding effects for the Commission Delegated Regulation (EU) No 134/2014. (See end of Document for details)

2.3.1.4.1. The complete test programme shall include at least 10 breaks lasting at least three hours in order to reproduce the effects of cooling and condensation.

2.3.1.4.2. Conditioning by pulsation

2.3.1.4.2. The exhaust system or components thereof shall be fitted to the moped or to the engine.

In the first case, the moped shall be mounted on a roller dynamometer. In the second case, the engine shall be mounted on a test bench. The test apparatus, as shown in detail in Figure Ap1-4, is fitted at the outlet of the exhaust system. Any other apparatus giving equivalent results is acceptable.

2.3.1.4.2. The test equipment shall be adjusted so that the flow of exhaust gases is alternately interrupted and restored 2 500 times by a rapid-action valve.

2.3.1.4.2. The valve shall open when the exhaust gas back-pressure, measured at least 100 mm downstream of the intake flange, reaches a value of between 0,35 and 0,40 bar. Should the engine characteristics prevent this, the valve shall open when the gas back-pressure reaches a level equivalent to 90 % of that which can be measured before the engine stops. It shall close when this pressure differs by no more than 10 % from its stabilised value with the valve open.

2.3.1.4.2. The time-lapse relay shall be set for the period in which exhaust gases are produced, calculated on the basis of the requirements of point 2.3.1.4.2.3.

2.3.1.4.2. Engine speed shall be 75 % of the speed (S) at which the engine develops maximum power.

2.3.1.4.2. The power indicated by the dynamometer shall be 50 % of the full-throttle power measured at 75 % of engine speed (S).

2.3.1.4.2. Any drainage holes shall be closed off during the test.

2.3.1.4.2. The entire test shall be completed within 48 hours. If necessary, a cooling period shall be allowed after each hour.

2.3.1.4.3. Conditioning on a test bench

2.3.1.4.3. The exhaust system shall be fitted to an engine representative of the type fitted to the moped for which the system is designed, and mounted on a test bench.

2.3.1.4.3. Conditioning consists of three test-bench cycles.

2.3.1.4.3. Each test-bench cycle shall be followed by a break of at least six hours in order to reproduce the effects of cooling and condensation.

2.3.1.4.3. Each test-bench cycle consists of six phases. The engine conditions and duration are as follows for each phase:

Table Ap1-1

Test-bench test cycle phases

Phase	Conditions	Duration of phase(minutes)
1	Idling	6
2	25 % load at 75 % S	40

Status: Point in time view as at 16/12/2013.

Changes to legislation: There are currently no known outstanding effects for the Commission Delegated Regulation (EU) No 134/2014. (See end of Document for details)

Table Ap1-1

Test-bench test cycle phases

3	50 % load at 75 % S	40
4	100 % load at 75 % S	30
5	50 % load at 100 % S	12
6	25 % load at 100 % S	22
Total time:		2 hrs. 30 mins

2.3.1.4.3. During this conditioning procedure, at the request of the manufacturer, the engine and the silencer may be cooled so that the temperature recorded at a point not more than 100 mm from the exhaust gas outlet does not exceed that measured when the moped is running at 75 % S in top gear. The engine and moped speeds shall be determined with an accuracy of $\pm 3\%$.

Figure Ap1-4

Test apparatus for conditioning by pulsation

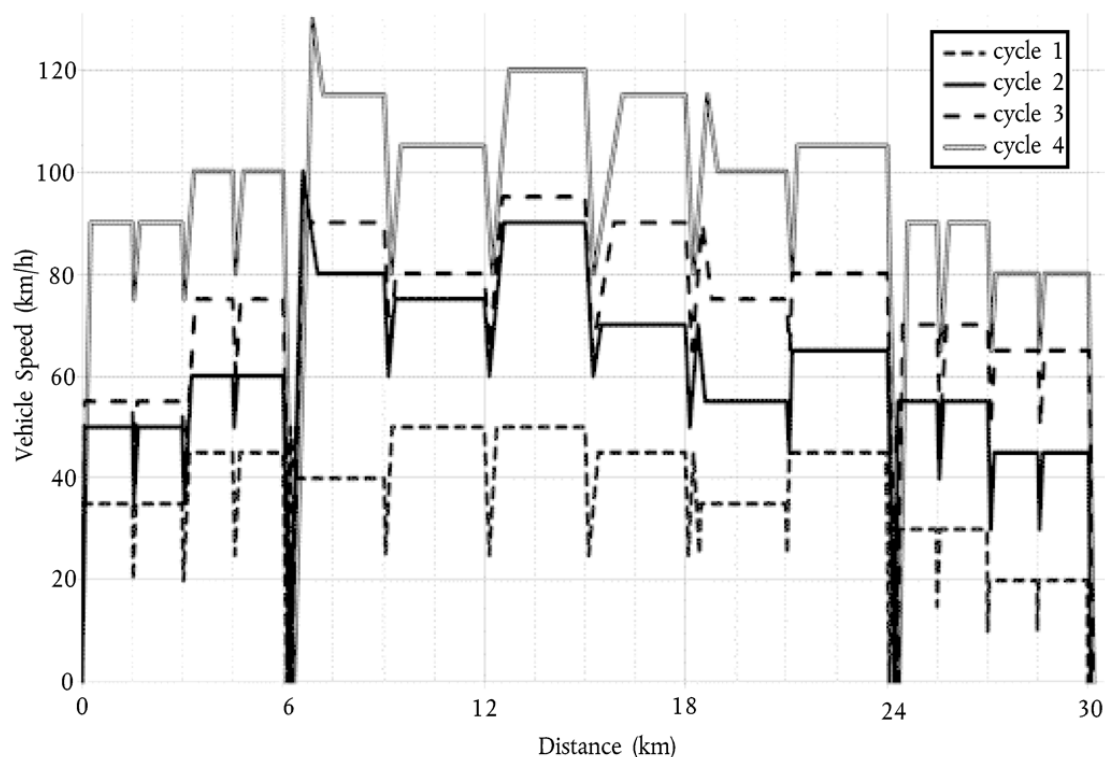

2.3.2. Diagram and markings

2.3.2.1. A diagram and a cross-sectional drawing indicating the dimensions of the exhaust system(s) shall be attached to the information document referred to in Article 27(4) of Regulation (EU) No 168/2013.

2.3.2.2. All original silencers shall bear at least the following:

- the 'e' mark followed by the reference to the country which granted the type-approval;

Status: Point in time view as at 16/12/2013.

Changes to legislation: There are currently no known outstanding effects for the Commission Delegated Regulation (EU) No 134/2014. (See end of Document for details)

- the vehicle manufacturer's name or trademark; and
- the make and identifying part number in compliance with Article 39 of Regulation (EU) No 168/2013.

This reference shall be legible, indelible and visible in the position at which it is to be fitted.

2.3.2.3. Any packing of original replacement silencer systems shall be marked legibly with the words 'original part' and the make and type references linked with the 'e' mark, together with the reference to the country of origin.

2.3.3. Intake silencer

If the engine intake has to be fitted with an air filter or intake silencer in order to comply with the permissible noise level, the filter or silencer shall be regarded as part of the silencer and the requirements of point 2.3 will also apply to them.

3. **Component type-approval of a non-original exhaust system or components thereof, as a separate technical unit, for two-wheel mopeds**

This point applies to the component type-approval, as separate technical units, of exhaust systems or components thereof intended to be fitted to one or more particular types of moped as non-original replacement parts.

3.1. Definition

3.1.1. 'Non-original replacement exhaust system or components thereof' means any exhaust system component as defined in point 1.2 intended to be fitted to a moped to replace that of the type fitted to the moped when the information document provided for in Article 27(4) of Regulation (EU) No 168/2013 was issued.

3.2. Application for component type-approval

3.2.1. Applications for component type-approval for replacement exhaust systems or components thereof as separate technical units shall be submitted by the manufacturer of the system or by his authorised representative.

3.2.2. For each type of replacement exhaust system or components thereof for which approval is requested, the component type-approval application shall be accompanied by the following documents in triplicate, and by the following particulars:

3.2.2.1. description, in respect of the characteristics referred to in point 1.1, of the types of moped for which the system(s) or component(s) is/are intended; the numbers or symbols specific to the type of engine and moped shall be given;

3.2.2.2. description of the replacement exhaust system stating the relative position of each of its components, together with the fitting instructions;

3.2.2.3. drawings of each component to facilitate location and identification, and statement of materials used. These drawings shall also indicate the intended location of the mandatory component type-approval mark.

3.2.3. The applicant shall submit, at the request of the technical service:

3.2.3.1. two samples of the system for which component type-approval is requested;

3.2.3.2. an exhaust system conforming to that originally fitted to the moped when the information document provided was issued;

Status: Point in time view as at 16/12/2013.

Changes to legislation: There are currently no known outstanding effects for the Commission Delegated Regulation (EU) No 134/2014. (See end of Document for details)

- 3.2.3.3. a moped representative of the type to which the replacement exhaust system is to be fitted, supplied in such a condition that, when fitted with a silencer of the same type as was originally fitted, it meets the requirements of either of the following two sections:
- 3.2.3.3.1. if the moped referred to in point 3.2.3.3 is of a type which has been granted type-approval pursuant to the provisions of this Appendix:
- 3.2.3.3.1.1. during the test in motion, it may not exceed by more than 1,0 dB(A) the applicable limit value laid down in point 2.1.1;
- 3.2.3.3.1.2. during the stationary test, it may not exceed by more than 3,0 dB(A) the value recorded when the moped was granted type-approval, as indicated on the manufacturer's data plate;
- 3.2.3.3.2. if the moped referred to in point 3.2.3.3 is not of a type which has been granted type-approval in accordance with the requirements of this Appendix, it may not exceed by more than 1,0 dB(A) the limit value applicable to that type of moped when it first entered into service;
- 3.2.3.4. a separate engine identical to that fitted to the moped referred in point 3.2.3.3., should the approval authorities deem it necessary.
- 3.3. Specifications
- 3.3.1. General specifications
- The design, construction and mounting of the silencer shall be such that:
- 3.3.1.1. the moped complies with the requirements of this Appendix under normal conditions of use, and in particular regardless of any vibrations to which it may be subjected;
- 3.3.1.2. it displays reasonable resistance to the corrosion phenomena to which it is exposed, with due regard to the normal conditions of use of the moped;
- 3.3.1.3. the ground clearance under the silencer as originally fitted, and the angle at which the moped can lean over, are not reduced;
- 3.3.1.4. the surface does not reach unduly high temperatures;
- 3.3.1.5. its outline has no projections or sharp edges;
- 3.3.1.6. shock absorbers and suspension have adequate clearance;
- 3.3.1.7. adequate safety clearance is provided for pipes;
- 3.3.1.8. it is impact-resistant in a way that is compatible with clearly defined maintenance and installation requirements.
- 3.3.2. Specifications for noise levels
- 3.3.2.1. The acoustic efficiency of the replacement exhaust systems or components thereof shall be tested using the methods described in points 2.1.2, 2.1.3, 2.1.4 and 2.1.5. Where a replacement exhaust system or component thereof is fitted to the moped referred to in point 3.2.3.3, the noise-level values obtained shall not exceed those measured, in accordance with point 3.2.3.3, using the same moped fitted with the original equipment silencer both during the test in motion and during the stationary test.
- 3.3.3. Testing of moped performance

Status: Point in time view as at 16/12/2013.

Changes to legislation: There are currently no known outstanding effects for the Commission Delegated Regulation (EU) No 134/2014. (See end of Document for details)

- 3.3.3.1. The replacement silencer shall be such as to ensure that the moped's performance is comparable with that achieved with the original silencer or component thereof.
- 3.3.3.2. The replacement silencer shall be compared with an originally-fitted silencer, also in new condition, fitted to the moped referred to in point 3.2.3.3.
- 3.3.3.3. This test shall be carried out by measuring the engine power curve. The net maximum power and the top speed measurements with the replacement silencer shall not deviate by more than $\pm 5\%$ from those taken under the same conditions with the original equipment silencer.
- 3.3.4. Additional provisions relating to silencers as separate technical units containing fibrous material

Fibrous material may not be used in the construction of such silencers unless the requirements set out in point 2.3.1 of this Annex are met.

- 3.3.5. Evaluation of the pollutant emissions of vehicles equipped with a replacement silencer system

The vehicle referred to in point 3.2.3.3, equipped with a silencer of the type for which approval is requested, shall undergo the applicable environmental tests according to the type-approval of the vehicle.

The requirements regarding environmental performance shall be deemed to be fulfilled if the results meet the limit values according to the type-approval of the vehicle as set out in Annex VI(D) of Regulation (EU) No 168/2013.

- 3.3.6. The marking of non-original exhaust systems or components thereof shall comply with the provisions of Article 39 of Regulation (EU) No 168/2013.

3.4. Component type-approval

- 3.4.1. Upon completion of the tests laid down in this Appendix, the approval authority shall issue a certificate corresponding to the model referred to in Article 30 (2) of Regulation (EU) No 168/2013. The component type-approval number shall be preceded by a rectangle surrounding the letter 'e' followed by the distinguishing number or letters of the Member State which issued or refused the component type-approval. The exhaust system which is granted system type-approval shall conform to the provisions of Annexes II and VI.

Status: Point in time view as at 16/12/2013.

Changes to legislation: There are currently no known outstanding effects for the Commission Delegated Regulation (EU) No 134/2014. (See end of Document for details)

Appendix 2

Sound level test requirements for motorcycles (categories L3e and L4e)

1. Definitions

For the purposes of this Appendix:

- 1.1. 'type of motorcycle as regards its sound level and exhaust system' means motorcycles which do not differ in such essential respects as the following:
 - 1.1.1. type of engine (two- or four-stroke, reciprocating piston engine or rotary-piston engine, number and capacity of cylinders, number and type of carburettors or injection systems, arrangement of valves, net maximum power and corresponding speed). The cubic capacity of rotary-piston engines shall be deemed to be double the volume of the chamber;
 - 1.1.2. Drive train, in particular the number and ratios of the gears of the transmission and final ratio;
 - 1.1.3. number, type and arrangement of exhaust systems;
- 1.2. 'exhaust system' or 'silencer' means a complete set of components necessary to limit the noise caused by a motorcycle engine and its exhaust;
 - 1.2.1. 'original exhaust system or silencer' means a system of the type fitted to the vehicle at the time of type-approval or extension of type-approval. It may be that first fitted or a replacement;
 - 1.2.2. 'non-original exhaust system or silencer' means a system of a type other than that fitted to the vehicle at the time of type-approval or extension of type-approval. It may be used only as a replacement exhaust system or silencer;
- 1.3. 'exhaust systems of differing types' means systems which are fundamentally different in one of the following ways:
 - 1.3.1. systems comprising components bearing different factory markings or trademarks;
 - 1.3.2. systems comprising any component made of materials of different characteristics or comprising components which are of a different shape or size;
 - 1.3.3. systems in which the operating principles of at least one component are different;
 - 1.3.4. systems comprising components in different combinations;
- 1.4. 'component of an exhaust system' means one of the individual components which together form the exhaust system (e.g. exhaust pipe work, the silencer proper) and the air intake system (air filter), if any.

If the engine has to be equipped with an air intake system (air filter or intake noise absorber) in order to comply with permissible noise levels, the filter or the absorber shall be treated as components having the same importance as the exhaust system.

2. **Component type-approval in respect of the sound level and original exhaust system, as a separate technical unit, of a type of motorcycle**

2.1. Noise of the motorcycle in motion (measuring conditions and method for testing of the vehicle during component type-approval)

2.1.1. Limits: see Part D of Annex VI to Regulation (EU) No 168/2013.

2.1.2. Measuring instruments

2.1.2.1. Acoustic measurements

The apparatus used for measuring the sound level shall be a precision sound-level meter of the type described in International Electro-technical Commission (IEC) publication 179 *Precision sound-level meters*, second edition. Measurements shall be taken using the 'fast' response and the 'A' weighting also described in that publication.

At the beginning and end of each series of measurements, the sound-level meter shall be calibrated in accordance with the manufacturer's instructions, using an appropriate noise source (e.g. piston phone).

2.1.2.2. Speed measurements

Engine speed and motorcycle speed on the test track shall be determined to within $\pm 3\%$.

2.1.3. Conditions of measurement

2.1.3.1. Condition of the motorcycle

During the measurements, the motorcycle shall be in running order.

Before the measurements are taken, the motorcycle shall be brought to normal operating temperature. If the motorcycle is fitted with fans with an automatic actuating mechanism, this system shall not be interfered with during the noise measurements. For motorcycles with more than one driven wheel, only the drive provided for normal road operation may be used. Where a motorcycle is fitted with a sidecar, this shall be removed for the purposes of the test.

2.1.3.2. Test site

The test site shall consist of a central acceleration section surrounded by a substantially flat test area. The acceleration section shall be flat; its surface shall be dry and such that surface noise remains low.

On the test site, the variations in the free sound field between the sound source at the centre of the acceleration section and the microphone shall not exceed 1,0 dB. This condition will be deemed to be met if there are no large objects which reflect sound, such as fences, rocks, bridges or buildings, within 50 m of the centre of the acceleration section. The surface covering of the test site shall conform to the requirements of Appendix 4.

The microphone shall not be obstructed in any way which could affect the sound field, and no person may stand between the microphone and the sound source. The observer carrying out the measurements shall so position himself as not to affect the readings of the measuring instrument.

2.1.3.3. Miscellaneous

Measurements shall not be taken in poor atmospheric conditions. It shall be ensured that the results are not affected by gusts of wind.

Status: Point in time view as at 16/12/2013.

Changes to legislation: There are currently no known outstanding effects for the Commission Delegated Regulation (EU) No 134/2014. (See end of Document for details)

For measurements, the A-weighted sound level of noise sources other than those of the vehicle to be tested and of wind effects shall be at least 10,0 dB(A) below the sound level produced by the vehicle. A suitable windscreen may be fitted to the microphone provided that account is taken of its effect on the microphone's sensitivity and directional characteristics.

If the difference between the ambient noise and the measured noise is between 10,0 and 16,0 dB(A), the test results shall be calculated by subtracting the appropriate correction from the readings on the sound-level meter, as in the following graph:

Figure Ap2-1

Difference between ambient noise and noise to be measured

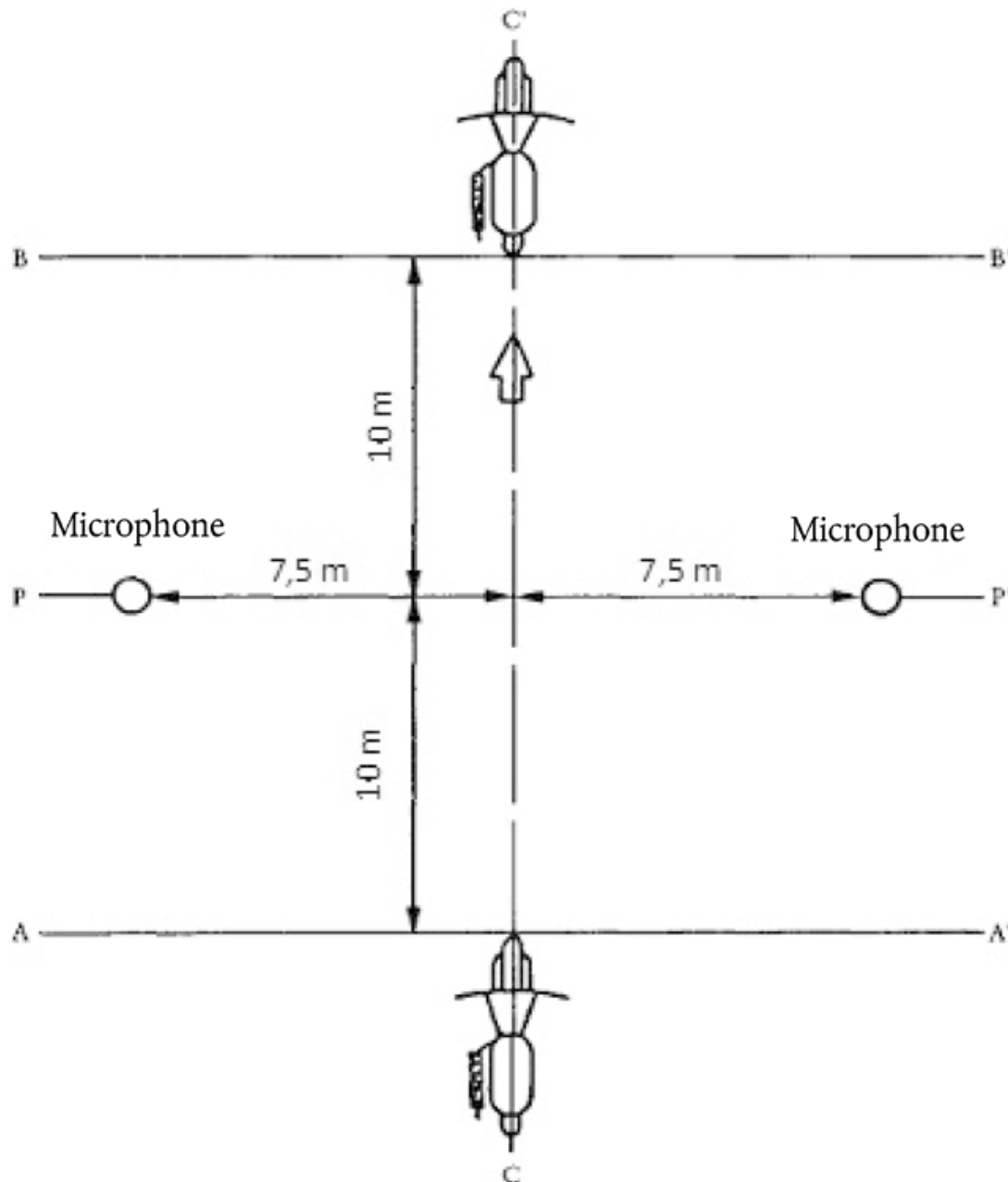

2.1.4. Method of measurement

2.1.4.1. Nature and number of measurements

The maximum noise level expressed in A-weighted decibels (dB(A)) shall be measured as the motorcycle travels between lines AA' and BB' (Figure Ap2-2). The measurement will be invalid if an abnormal discrepancy is recorded between the peak value and the general sound level.

At least two measurements shall be taken on each side of the motorcycle.

2.1.4.2. Positioning of the microphone

The microphone shall be positioned 7.5 m ± 0.2 m from the reference line CC' (Figure Ap2-2) of the track and 1.2 m ± 0.1 m above ground level.

2.1.4.3. Conditions of operation

The motorcycle shall approach line AA' at an initial steady speed as specified in points 2.1.4.3.1 and 2.1.4.3.2. When the front of the motorcycle reaches line AA', the throttle shall be fully opened as quickly as practically possible and kept in that position until the rear of the motorcycle reaches line BB'; the throttle shall then be returned as quickly as possible to the idle position.

For all measurements, the motorcycle shall be ridden in a straight line over the acceleration section keeping the longitudinal median plane of the motorcycle as close as possible to line CC'.

2.1.4.3.1. Motorcycles with non-automatic gearboxes

2.1.4.3.1.1. Approach speed

The motorcycle shall approach line AA' at a steady speed

- of 50 km/h, or
- corresponding to an engine speed equal to 75 % of the engine speed at which maximum net power is developed,

whichever is the lower.

2.1.4.3.1.2. Selection of gear ratio

2.1.4.3.1.1. Motorcycles fitted with a gearbox with four ratios or fewer, whatever the cylinder capacity of their engines, shall be tested only in second gear.

2.1.4.3.1.2. Motorcycles fitted with engines with a cylinder capacity not exceeding 175 cm³ and a gearbox with five ratios or more shall be tested only in third gear.

2.1.4.3.1.3. Motorcycles fitted with engines having a cylinder capacity of more than 175 cm³ and a gearbox with five ratios or more shall be tested once in second gear and once in third gear. The result used shall be the average of the two tests.

2.1.4.3.1.4. If during the test carried out in second gear (see points 2.1.4.3.1.2.1 and 2.1.4.3.1.2.3), the engine speed on the approach to the line marking the end of the test track exceeds 100 % of the engine speed at which maximum net power is developed, the test shall be carried out in third gear and the noise level measured shall be the only one recorded as the test result.

2.1.4.3.2. Motorcycles with automatic gearboxes

2.1.4.3.2.1. Motorcycles without a manual selector

2.1.4.3.2.1.1. Approach speed

Status: Point in time view as at 16/12/2013.

Changes to legislation: There are currently no known outstanding effects for the Commission Delegated Regulation (EU) No 134/2014. (See end of Document for details)

The motorcycle shall approach line AA' at steady speeds of 30, 40 and 50 km/h or 75 % of the maximum road speed if that value is lower. The condition giving the highest sound level is chosen.

2.1.4.3.2. Motorcycles equipped with a manual selector with X forward drive positions

2.1.4.3.2.1. Approach speed

The motorcycle shall approach line AA' at a steady speed of:

- less than 50 km/h, the engine rotation speed being equal to 75 % of the engine speed at which maximum net power is developed, or
- 50 km/h, the engine rotation speed being less than 75 % of the engine speed at which maximum net power is developed.

If, in the test at a steady speed of 50 km/h, the gears change down to first, the approach speed of the motorcycle may be increased to a maximum of 60 km/h to avoid the downshift.

2.1.4.3.2.2. Position of the manual selector

If the motorcycle is equipped with a manual selector with 'X' forward drive positions, the test shall be carried out with the selector in the highest position; the voluntary device for changing down (e.g. kick-down) shall not be used. If an automatic downshift takes place after line AA', the test shall be started again using the second-highest position, or the third-highest position if necessary, in order to find the highest position of the selector at which the test can be performed without an automatic downshift (without using the kick-down).

2.1.4.4. For hybrid L-category vehicles, the tests shall be performed twice under the following conditions:

- (a) condition A: batteries shall be at their maximum state of charge; if more than one 'hybrid mode' is available, the most electric mode shall be selected for the test;
- (b) condition B: batteries shall be at their minimum state of charge; if more than one 'hybrid mode' is available, the most fuel-consuming mode shall be selected for the test.

2.1.5. Results (test report)

2.1.5.1. The test report drawn up for the purpose of issuing the information folder according to the template referred to in Article 27(4) of Regulation (EU) No 168/2013 shall indicate any circumstances and factors affecting the results of the measurements.

2.1.5.2. Readings taken shall be rounded to the nearest decibel.

If the figure following the decimal point is between 0 and 4, the total is rounded down and if between 5 and 9, it is rounded up.

Only measurements which vary by 2,0 dB(A) or less in two consecutive tests on the same side of the motorcycle may be used for the purpose of issuing the information document according to the template referred to in Article 27(4) of Regulation (EU) No 168/2013.

2.1.5.3. To take account of inaccuracies, 1,0 dB(A) shall be deducted from each value obtained in accordance with point 2.1.5.2.

2.1.5.4. If the average of the four measurements does not exceed the maximum permissible level for the vehicle category in question, the limit laid down in Part D of Annex VI to Regulation (EU) No 168/2013 will be deemed as being complied with. This average value shall be taken as the result of the test.

Status: Point in time view as at 16/12/2013.

Changes to legislation: There are currently no known outstanding effects for the Commission Delegated Regulation (EU) No 134/2014. (See end of Document for details)

- 2.1.5.5. If the average of four Condition A results and the average of four Condition B results do not exceed the permissible level for the vehicle category in question, the limits laid down in Part D of Annex VI to Regulation (EU) No 168/2013 shall be deemed as being complied with.

The highest average value shall be taken as the result of the test.

- 2.2. Noise from stationary motorcycle (measuring conditions and method for testing of the vehicle in use)

- 2.2.1. Sound-pressure level in the immediate vicinity of the motorcycle

In order to facilitate subsequent noise tests on motorcycles in use, the sound-pressure level in the immediate vicinity of the exhaust-system outlet shall be measured in accordance with the following requirements, the result being entered in the test report drawn up for the purpose of issuing the information document according to the template referred to in Article 27(4) of Regulation (EU) No 168/2013.

- 2.2.2. Measuring instruments

A precision sound-level meter as defined in point 2.1.2.1 shall be used.

- 2.2.3. Conditions of measurement

- 2.2.3.1. Condition of the motorcycle

Before the measurements are taken, the motorcycle engine shall be brought to normal operating temperature. If the motorcycle is fitted with fans with an automatic actuating mechanism, this system shall not be interfered with during the noise measurements.

During the measurements, the gearbox shall be in neutral gear. If it is impossible to disconnect the drive train, the driving wheel of the motorcycle shall be allowed to rotate freely, e.g. by placing the vehicle on its centre stand.

- 2.2.3.2. Test site (Figure Ap2-2)

Any area in which there are no significant acoustic disturbances may be used as a test site. Flat surfaces which are covered with concrete, asphalt or some other hard material and are highly reflective are suitable; surfaces consisting of earth which has been tamped down shall not be used. The test site shall be in the form of a rectangle the sides of which are at least 3 m from the outer edge of the motorcycle (handlebars excluded). There shall be no significant obstacles, e.g. no persons other than the rider and the observer may stand within this rectangle.

The motorcycle shall be positioned within the rectangle so that the microphone used for measurement is at least 1 m from any kerb.

- 2.2.3.3. Miscellaneous

Instrument readings caused by ambient noise and wind effects shall be at least 10,0 dB(A) lower than the sound levels to be measured. A suitable windshield may be fitted to the microphone provided that account is taken of its effect on the sensitivity of the microphone.

- 2.2.4. Method of measurement

- 2.2.4.1. Nature and number of measurements

The maximum sound level expressed in A-weighted decibels (dB(A)) shall be measured during the period of operation laid down in point 2.2.4.3.

Status: Point in time view as at 16/12/2013.

Changes to legislation: There are currently no known outstanding effects for the Commission Delegated Regulation (EU) No 134/2014. (See end of Document for details)

At least three measurements shall be taken at each measuring point.

2.2.4.2. Positioning of the microphone (Figure Ap2-3)

The microphone shall be positioned level with the exhaust outlet or 0,2 m above the surface of the track, whichever is the higher. The microphone diaphragm shall face the exhaust outlet at a distance of 0,5 m from it. The axis of maximum sensitivity of the microphone shall be parallel to the surface of the track at an angle of $45 \pm 10^\circ$ to the vertical plane of the direction of the exhaust emissions.

In relation to this vertical plane, the microphone shall be positioned on the side on which there is the maximum possible distance between the microphone and the outline of the motorcycle (handlebars excluded).

If the exhaust system has more than one outlet at centres less than 0.3 m apart, the microphone shall face the outlet which is nearest the motorcycle (handlebars excluded) or the outlet which is highest above the surface of the track. If the centres of the outlets are more than 0.3 m apart, separate measurements shall be taken for each of them, the highest figure recorded being taken as the test value.

2.2.4.3. Operating conditions

The engine speed shall be held steady at:

- $((S)/(2))$ if S is more than 5 000 rpm, or
- $((3S)/(4))$, if S is not more than 5 000 rpm,

where S is the engine speed at which the maximum net power is developed.

When a constant engine speed is reached, the throttle shall be returned swiftly to the idle position. The sound level shall be measured during an operating cycle consisting of a brief period of constant engine speed and throughout the deceleration period, the maximum sound-level meter reading being taken as the test value.

2.2.5. Results (test report)

2.2.5.1. The test report drawn up for the purpose of issuing the information document according to the template referred to in Article 27(4) of Regulation (EU) No 168/2013 shall indicate all relevant data and particularly those used in measuring the noise of the stationary motorcycle.

2.2.5.2. Values shall be read off the measuring instrument and rounded to the nearest decibel.

If the figure following the decimal point is between 0 and 4, the total is rounded down and if between 5 and 9, it is rounded up.

Only measurements which vary by no more than 2,0 dB(A) in three consecutive tests will be used.

2.2.5.3. The highest of the three measurements will be taken as the test result.

Figure Ap2-2

Status: Point in time view as at 16/12/2013.

Changes to legislation: There are currently no known outstanding effects for the Commission Delegated Regulation (EU) No 134/2014. (See end of Document for details)

Test for vehicle in motion

Test for stationary vehicle

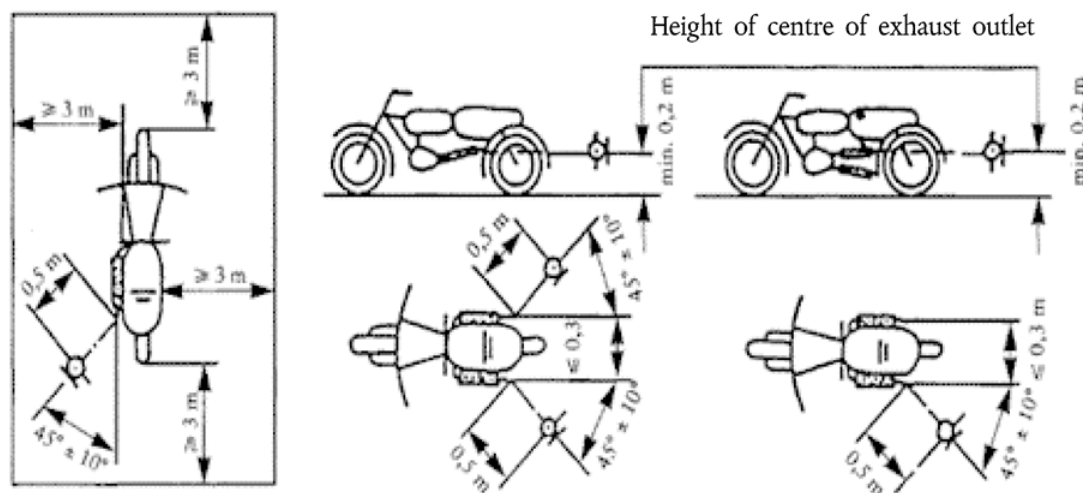
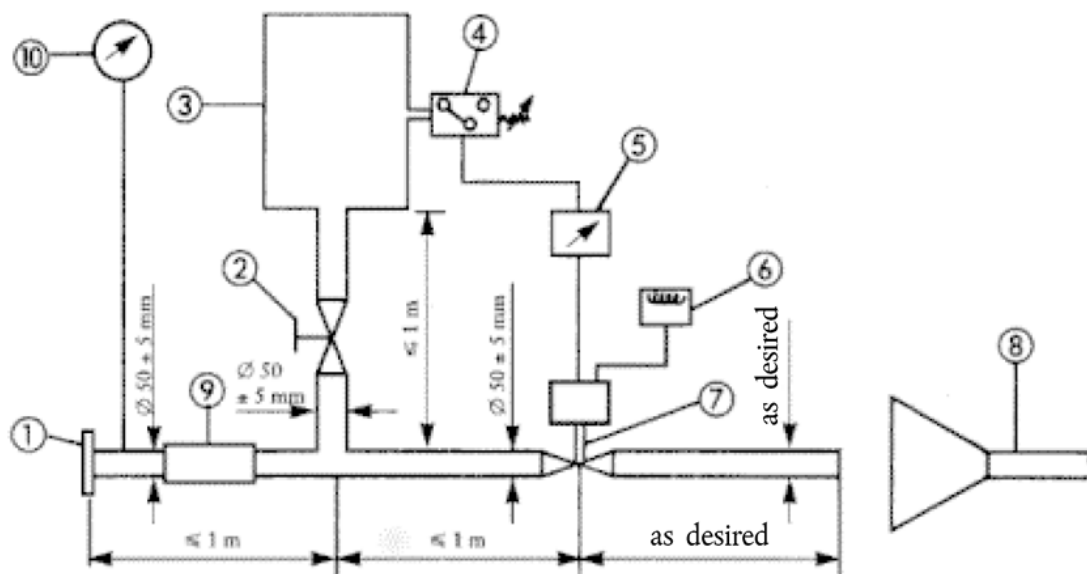

Figure Ap2-3

Test for stationary vehicle



2.3. Original exhaust system (silencer)

2.3.1. Requirements for silencers containing absorbent fibrous materials

2.3.1.1. Absorbent fibrous material shall be asbestos-free and may be used in the construction of silencers only if it is held securely in place throughout the service life of the silencer and it meets the requirements of point 2.3.1.2 or 2.3.1.3.

2.3.1.2. After removal of the fibrous material, the sound level shall comply with the requirements of point 2.1.1.

Status: Point in time view as at 16/12/2013.

Changes to legislation: There are currently no known outstanding effects for the Commission Delegated Regulation (EU) No 134/2014. (See end of Document for details)

2.3.1.3. The absorbent fibrous material may not be placed in those parts of the silencer through which the exhaust gases pass, and shall comply with the following requirements:

2.3.1.3.1. the material shall be heated at a temperature of $650\text{ °C} \pm 5\text{ °C}$ for four hours in a furnace without reduction in the average length, diameter or bulk density of the fibre;

2.3.1.3.2. after being heated at $650\text{ °C} \pm 5\text{ °C}$ for one hour in a furnace, at least 98 % of the material shall be retained in a sieve of nominal mesh size $250\text{ }\mu\text{m}$ complying with technical standard ISO 3310-1:2000 when tested in accordance with ISO standard 2559:2011;

2.3.1.3.3. the material shall not lose more than 10.5 % of its weight after being soaked for 24 hours at $90\text{ °C} \pm 5\text{ °C}$ in a synthetic condensate of the following composition:

- 1 N hydrobromic acid (HBr): 10 ml
- 1 N sulphuric acid (H₂SO₄): 10 ml
- Distilled water to make up to 1 000 ml.

Note: The material shall be washed in distilled water and dried for one hour at 105 °C before weighing.

2.3.1.4. Before the system is tested in accordance with point 2.1, it shall be put in normal working order by one of the following methods:

2.3.1.4.1. Conditioning by continuous road operation

2.3.1.4.1.1. Table Ap2-1 shows the minimum distance to be travelled for each category of motorcycle during conditioning:

TABLE AP2-1

Minimum distance to be travelled during conditioning

L3e / L4e category vehicle (motorcycle) by engine capacity (cm ³)	Distance(km)
1. ≤ 80	4 000
2. $> 80 \leq 175$	6 000
3. > 175	8 000

2.3.1.4.1.3. $30 \pm 10\%$ of this conditioning cycle shall consist of town driving and the remainder of long-distance runs at high speed; the continuous road cycle may be replaced by a corresponding test-track programme.

2.3.1.4.1.3. The two types of driving shall be alternated at least six times.

2.3.1.4.1.4. The complete test programme shall include at least ten breaks lasting at least three hours in order to reproduce the effects of cooling and condensation.

2.3.1.4.2. Conditioning by pulsation

2.3.1.4.2. The exhaust system or components thereof shall be fitted to the motorcycle or to the engine.

Status: Point in time view as at 16/12/2013.

Changes to legislation: There are currently no known outstanding effects for the Commission Delegated Regulation (EU) No 134/2014. (See end of Document for details)

In the first case, the motorcycle shall be mounted on a roller dynamometer. In the second case, the engine shall be mounted on a test bench.

The test apparatus, as shown in detail in Figure Ap2-4, is fitted at the outlet of the exhaust system. Any other apparatus giving equivalent results is acceptable.

2.3.1.4.2. The test equipment shall be adjusted so that the flow of exhaust gases is alternately interrupted and restored 2 500 times by a rapid-action valve.

2.3.1.4.2. The valve shall open when the exhaust gas back-pressure, measured at least 100 mm downstream of the intake flange, reaches a value of between 0.35 and 0.40 bar. Should the engine characteristics prevent this, the valve shall open when the gas back-pressure reaches a level equivalent to 90 % of that which can be measured before the engine stops. It shall close when this pressure differs by no more than 10 % from its stabilised value with the valve open.

2.3.1.4.2. The time-lapse relay shall be set for the period in which exhaust gases are produced, calculated on the basis of the requirements of point 2.3.1.4.2.3.

2.3.1.4.2. Engine speed shall be 75 % of the speed (S) at which the engine develops maximum power.

2.3.1.4.2. The power indicated by the dynamometer shall be 50 % of the full-throttle power measured at 75 % of engine speed (S).

2.3.1.4.2. Any drainage holes shall be closed off during the test.

2.3.1.4.2. The entire test shall be completed within 48 hours. If necessary, a cooling period shall be allowed after each hour.

2.3.1.4.3. Conditioning on a test bench

2.3.1.4.3. The exhaust system shall be fitted to an engine representative of the type fitted to the motorcycle for which the system is designed and mounted on a test bench.

2.3.1.4.3. Conditioning consists of the specified number of test bench cycles for the category of motorcycle for which the exhaust system was designed. Table Ap2-2 shows the number of cycles for each category of motorcycle:

TABLE AP2-2

Number of test-bench cycles for conditioning

Category of motorcycle by cylinder capacity(cm ³)	Number of cycles
1. ≤ 80	6
2. > 80 ≤ 175	9
3. > 175	12

2.3.1.4.3. Each test-bench cycle shall be followed by a break of at least six hours in order to reproduce the effects of cooling and condensation.

Status: Point in time view as at 16/12/2013.

Changes to legislation: There are currently no known outstanding effects for the Commission Delegated Regulation (EU) No 134/2014. (See end of Document for details)

2.3.1.4.3. Each test-bench cycle consists of six phases. The engine conditions and duration are as follows for each phase:

TABLE AP2-3

Test cycle phases for bench testing

Phase	Conditions	Duration of phase(minutes)	
		Engines with displacement less than 175 cm ³	Engines with displacement of 175 cm ³ or more
1	Idling	6	6
2	25 % load at 75 % S	40	50
3	50 % load at 75 % S	40	50
4	100 % load at 75 % S	30	10
5	50 % load at 100 % S	12	12
6	25 % load at 100 % S	22	22
Total time:		2 hours 30 mins	2 hours 30 mins

2.3.1.4.3. During this conditioning procedure, at the request of the manufacturer, the engine and the silencer may be cooled so that the temperature recorded at a point not more than 100 mm from the exhaust gas outlet does not exceed that measured when the motorcycle is running at 110 km/h or 75 % S in top gear. The engine or motorcycle speeds shall be determined with an accuracy of ± 3 %.

Figure Ap2-4

Test apparatus for conditioning by pulsation

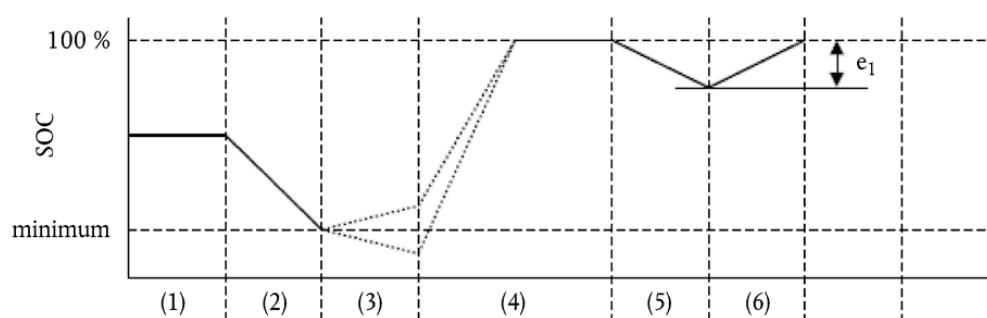

2.3.2. Diagram and markings

2.3.2.1. A diagram and a cross-sectional drawing indicating the dimensions of the exhaust system shall be annexed to the information document according to the template referred to in Article 27(4) of Regulation (EU) No 168/2013.

2.3.2.2. All original silencers shall bear at least the following:

- the 'e' mark followed by the reference to the country which granted the type-approval;
- the vehicle manufacturer's name or trademark; and
- the make and identifying part number.

This reference shall be legible, indelible and visible in the position at which it is to be fitted.

2.3.2.3. Any packing of original replacement silencer systems shall be marked legibly with the words ‘original part’ and the make and type references linked with the ‘e’ mark and also the reference to the country of origin.

2.3.3. Intake silencer

If the engine intake has to be fitted with an air filter or intake silencer in order to comply with the permissible sound level, the filter or silencer shall be regarded as part of the silencer and the requirements of point 2.3 also apply to them.

3. **Component type-approval of a non-original exhaust system or components thereof, as technical units, for motorcycles**

This section applies to the component type-approval, as technical units, of exhaust systems or components thereof intended to be fitted to one or more particular types of motorcycle as non-original replacement parts.

3.1. Definition

3.1.1. ‘Non-original replacement exhaust system or components thereof’ means any exhaust system component as defined in point 1.2 intended to be fitted to a motorcycle to replace that of the type fitted to the motorcycle when the information document according to the template referred to in Article 27(4) of Regulation (EU) No 168/2013 was issued.

3.2. Application for component type-approval

3.2.1. Applications for component type-approval for replacement exhaust systems or components thereof as separate technical units shall be submitted by the manufacturer of the system or by his authorised representative.

3.2.2. For each type of replacement exhaust system or components thereof for which approval is requested, the component type-approval application shall be accompanied by the following documents in triplicate, and by the following particulars:

3.2.2.1. description, in respect of the characteristics referred to in section 1.1 of this Appendix, of the types of motorcycle for which the system(s) or component(s) is/are intended; the numbers or symbols specific to the type of engine and motorcycle shall be given;

3.2.2.2. description of the replacement exhaust system stating the relative position of each of its components, together with the fitting instructions;

3.2.2.3. drawings of each component to facilitate location and identification, and statement of materials used. These drawings shall also indicate the intended location of the mandatory component type-approval mark.

3.2.3. The applicant shall submit, at the request of the technical service:

3.2.3.1. two samples of the system for which component type-approval is requested;

3.2.3.2. an exhaust system conforming to that originally fitted to the motorcycle when the information document according to the template referred to in Regulation (EU) No 168/2013 was issued;

3.2.3.3. a motorcycle representative of the type to which the replacement exhaust system is to be fitted, supplied in such a condition that, when fitted with a silencer of the same

Status: Point in time view as at 16/12/2013.

Changes to legislation: There are currently no known outstanding effects for the Commission Delegated Regulation (EU) No 134/2014. (See end of Document for details)

type as was originally fitted, it meets the requirements of either of the following two sections:

3.2.3.3.1. If the motorcycle referred to in point 3.2.3.3 is of a type which has been granted type-approval pursuant to the provisions of this Appendix:

- during the test in motion, it may not exceed by more than 1,0 dB(A) the limit value laid down in point 2.1.1;
- during the stationary test, it may not exceed by more than 3,0 dB(A) the value recorded when the motorcycle was granted type-approval and indicated on the manufacturer's data plate.

3.2.3.3.2. If the motorcycle referred to in point 3.2.3.3 is not of a type which has been granted type-approval pursuant to the provisions of this Regulation, it may not exceed by more than 1,0 dB(A) the limit value applicable to that type of motorcycle when it first entered into service;

3.2.3.4. a separate engine identical to that fitted to the motorcycle referred to in point 3.2.3.3., should the approval authorities deem it necessary.

3.3. Markings and inscriptions

3.3.1. Non-original exhaust systems or components thereof shall be marked in accordance with the requirements laid down in Article 39 of Regulation (EU) No 168/2013.

3.4. Component type-approval

3.4.1. Upon completion of the tests laid down in this Appendix, the approval authority shall issue a certificate corresponding to the model referred to in Article 30(2) of Regulation (EU) No 168/2013. The component type-approval number shall be preceded by a rectangle surrounding the letter 'e' followed by the distinguishing number or letters of the Member State which issued or refused the component type-approval. The exhaust system which is granted system type-approval shall conform to the provisions of Annexes II and VI.

3.5. Specifications

3.5.1. General specifications

The design, construction and mounting of the silencer shall be such that:

3.5.1.1. the motorcycle complies with the requirements of this Appendix under normal conditions of use, and in particular regardless of any vibrations to which it may be subjected;

3.5.1.2. it displays reasonable resistance to the corrosion phenomena to which it is exposed, with due regard to the normal conditions of use of the motorcycle;

3.5.1.3. the ground clearance under the silencer as originally fitted, and the angle at which the motorcycle can lean over, are not reduced;

3.5.1.4. the surface does not reach unduly high temperatures;

3.5.1.5. its outline has no projections or sharp edges;

3.5.1.6. shock absorbers and suspension have adequate clearance;

3.5.1.7. adequate safety clearance is provided for pipes;

Status: Point in time view as at 16/12/2013.

Changes to legislation: There are currently no known outstanding effects for the Commission Delegated Regulation (EU) No 134/2014. (See end of Document for details)

3.5.1.8. it is impact-resistant in a way that is compatible with clearly-defined maintenance and installation requirements.

3.5.2. Specifications for sound levels

3.5.2.1. The acoustic efficiency of the replacement exhaust systems or components thereof shall be tested using the methods described in points 2.1.2, 2.1.3, 2.1.4 and 2.1.5.

With a replacement exhaust system or component thereof fitted to the motorcycle referred to in point 3.2.3.3, the noise-level values obtained shall not exceed the values measured, in accordance with point 3.2.3.3, using the same motorcycle fitted with the original equipment silencer both during the test in motion and during the stationary test.

3.5.3. Testing of motorcycle performance

3.5.3.1. The replacement silencer shall be such as to ensure that the motorcycle's performance is comparable with that achieved with the original silencer or component thereof.

3.5.3.2. The replacement silencer shall be compared with an originally-fitted silencer, also in new condition, fitted to the motorcycle referred to in point 3.2.3.3.

3.5.3.3. This test is carried out by measuring the engine power curve. The net maximum power and the top speed measurements with the replacement silencer shall not deviate by more than ± 5 % from those taken under the same conditions with the original equipment silencer.

3.5.4. Additional provisions relating to silencers as separate technical units containing fibrous material

Fibrous material may not be used in the construction of such silencers unless the requirements set out in point 2.3.1 are met.

3.5.5. Evaluation of the pollutant emissions of vehicles equipped with a replacement silencer system

The vehicle referred to in point 3.2.3.3, equipped with a silencer of the type for which approval is requested, shall undergo a type I, II and V test under the conditions described in the corresponding Annexes II, III and VI according to the type-approval of the vehicle.

The requirements regarding emissions shall be deemed to be fulfilled if the results are within the limit values according to the type-approval of the vehicle.

Status: Point in time view as at 16/12/2013.

Changes to legislation: There are currently no known outstanding effects for the Commission Delegated Regulation (EU) No 134/2014. (See end of Document for details)

Appendix 3

Sound level test requirements for three-wheel mopeds, tricycles and quadricycles (categories L2e, L5e, L6e and L7e)

1. Definitions

For the purposes of this Appendix:

- 1.1. 'type of three-wheel moped, tricycle or quadricycle as regards its sound level and exhaust system' means three-wheel mopeds and tricycles which do not differ in such essential respects as the following:
 - 1.1.1. bodywork shape or materials (in particular the engine compartment and its soundproofing);
 - 1.1.2. vehicle length and width;
 - 1.1.3. type of engine (spark ignition or compression ignition, two- or four-stroke, reciprocating piston or rotary piston, number and capacity of cylinders, number and type of carburettors or injection systems, arrangement of valves, net maximum power and corresponding speed); the cubic capacity of rotary-piston engines shall be deemed to be double the swept volume;
 - 1.1.4. drive train, in particular the number and ratios of the gears of the transmission and the final ratio;
 - 1.1.5. number, type and arrangement of exhaust systems;
- 1.2. 'exhaust system' or 'silencer' means a complete set of components necessary to limit the noise caused by the engine and exhaust of a three-wheel moped, tricycle or quadricycle;
 - 1.2.1. 'original exhaust system or silencer' means a system of the type fitted to the vehicle at the time of type-approval or extension of type-approval. It may be that first fitted or a replacement;
 - 1.2.2. 'non-original exhaust system or silencer' means a system of a type other than that fitted to the vehicle at the time of type-approval or extension of type-approval. It may be used only as a replacement exhaust system or silencer;
- 1.3. 'exhaust systems of differing types' means systems which are fundamentally different in one of the following ways:
 - 1.3.1. systems comprising components bearing different factory markings or trademarks;
 - 1.3.2. systems comprising any component made of materials of different characteristics or comprising components which are of a different shape or size;
 - 1.3.3. systems in which the operating principles of at least one component are different;
 - 1.3.4. systems comprising components in different combinations;

- 1.4. ‘component of an exhaust system’ means one of the individual components which together form the exhaust system (such as exhaust pipe work, the silencer proper) and the air intake system (air filter) if any.

If the engine has to be equipped with an air intake system (air filter or intake noise absorber) in order to comply with maximum permissible sound levels, the filter or the absorber must be treated as a component having the same importance as the exhaust system.

2. **Component type-approval in respect of the sound level and original exhaust system, as a separate technical unit, of a type of three-wheel moped (L2e), a tricycle (L5e), a light quadricycle (L6e) or heavy quadricycles (L7e)**

- 2.1. Noise of the three-wheel moped, tricycle or quadricycle (measuring conditions and method for testing of the vehicle during component type-approval)

2.1.1. The vehicle, its engine and its exhaust system shall be designed, constructed and assembled so that the vehicle complies with the requirements of this Appendix under normal conditions of use, regardless of any vibrations to which they may be subjected.

2.1.2. The exhaust system shall be designed, constructed and mounted to resist the corrosion phenomena to which it is exposed.

- 2.2. Specifications for noise levels

2.2.1. Limits: see Part D of Annex VI to Regulation (EU) No 168/2013.

2.2.2. Measuring instruments

2.2.2.1. The apparatus used for measuring the noise level shall be a precision sound-level meter of the type described in International Electro-technical Commission (IEC) publication No 179 *Precision sound-level meters*, second edition. Measurements shall be carried out using the ‘fast’ response of the sound-level meter and the ‘A’ weighting also described in that publication.

At the beginning and end of each series of measurements, the sound-level meter shall be calibrated in accordance with the manufacturer’s instructions, using an appropriate noise source (e.g. a piston phone).

2.2.2.2. Speed measurements.

Engine speed and vehicle speed on the test track shall be determined to within ± 3 %.

2.2.3. Conditions of measurement

2.2.3.1. Condition of the vehicle

During the measurements, the vehicle shall be in running order (including coolant, oils, fuel, tools, spare wheel and rider). Before the measurements are taken, the vehicle shall be brought to the normal operating temperature.

2.2.3.1.1. The measurements shall be taken with the vehicles unladen and without trailer or semitrailer.

2.2.3.2. Test site

The test site shall consist of a central acceleration section surrounded by a substantially flat test area. The acceleration section shall be flat; its surface shall be dry and such that surface noise remains low.

Status: Point in time view as at 16/12/2013.

Changes to legislation: There are currently no known outstanding effects for the Commission Delegated Regulation (EU) No 134/2014. (See end of Document for details)

On the test site, the variations in the free sound field between the sound source at the centre of the acceleration section and the microphone shall not exceed ± 1.0 dB(A). This condition will be deemed to be met if there are no large objects which reflect sound, such as fences, rocks, bridges or buildings, within 50 m of the centre of the acceleration section. The surface covering of the test track shall conform to the requirements of Appendix 4.

The microphone shall not be obstructed in any way which could affect the sound field, and no person may stand between the microphone and the sound source. The observer carrying out the measurements shall so position himself as not to affect the readings of the measuring instrument.

2.2.3.3. Miscellaneous

Measurements shall not be taken in poor atmospheric conditions. It shall be ensured that the results are not affected by gusts of wind.

For measurements, the A-weighted noise level of noise sources other than those of the vehicle to be tested and of wind effects shall be at least 10,0 dB(A) below the noise level produced by the vehicle. A suitable windscreen may be fitted to the microphone provided that account is taken of its effect on the sensitivity and directional characteristics of the microphone.

If the difference between the ambient noise and the measured noise is between 10,0 and 16,0 dB(A), the test results shall be calculated by subtracting the appropriate correction from the readings on the sound-level meter, as in the following graph:

Figure Ap3-1

Status: Point in time view as at 16/12/2013.

Changes to legislation: There are currently no known outstanding effects for the Commission Delegated Regulation (EU) No 134/2014. (See end of Document for details)

Difference between ambient noise and noise level to be measured

Test for vehicle in motion

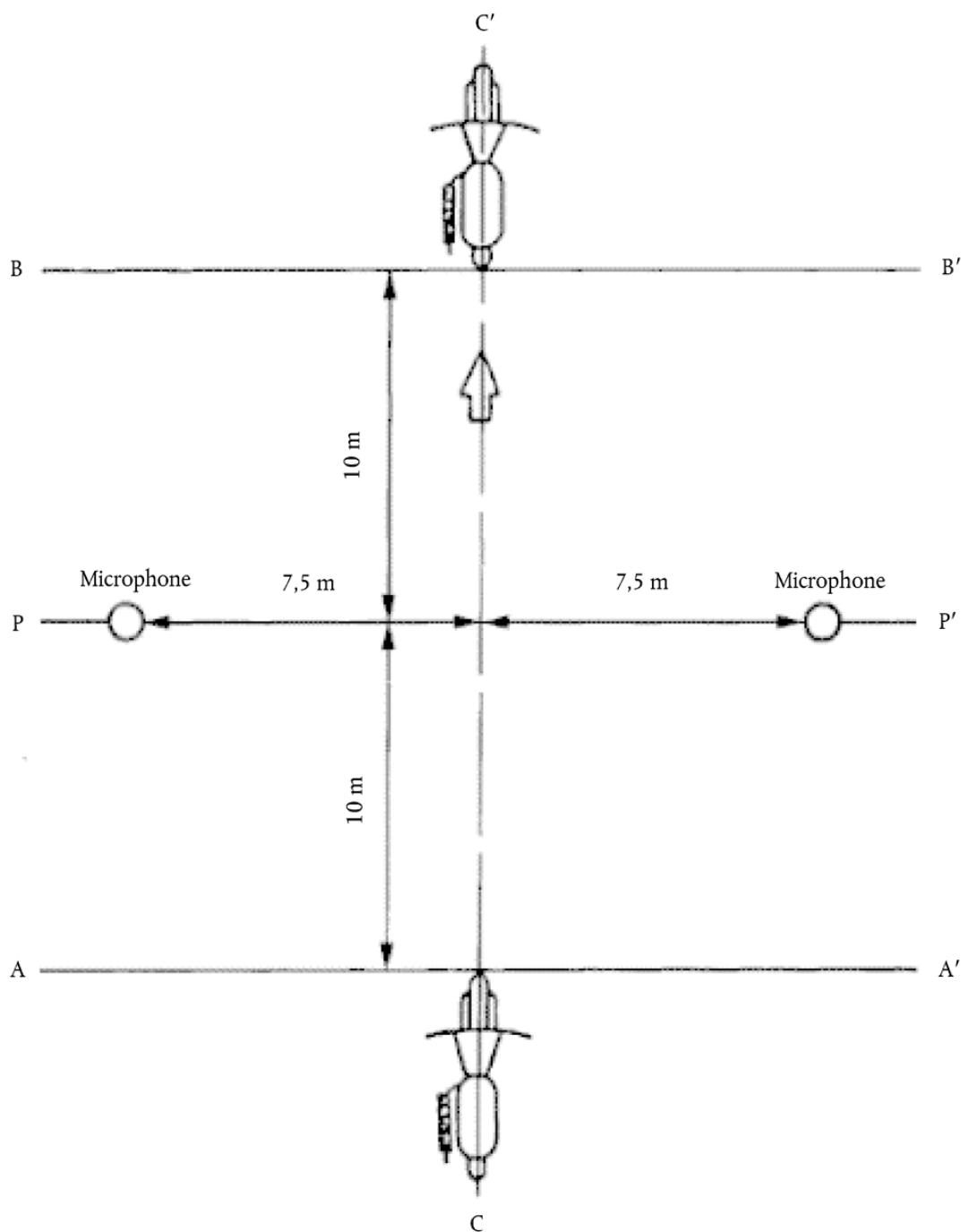

2.2.4. Method of measurement

2.2.4.1. Nature and number of measurements

Status: Point in time view as at 16/12/2013.

Changes to legislation: There are currently no known outstanding effects for the Commission Delegated Regulation (EU) No 134/2014. (See end of Document for details)

The maximum noise level expressed in A-weighted decibels (dB(A)) shall be measured as the vehicle travels between lines AA' and BB' (Figure Ap3-2). The measurement will be invalid if an abnormal discrepancy between the peak value and the general noise level is recorded.

At least two measurements shall be taken on each side of the vehicle.

2.2.4.2. Positioning of the microphone

The microphone shall be positioned 7,5 m \pm 0,2 m from the reference line CC' (Figure Ap3-2) of the track and 1,2 m \pm 0,1 m above ground level.

2.2.4.3. Conditions of operation

The vehicle shall approach line AA' at an initial steady speed as specified in point 2.2.4.4. When the front of the vehicle reaches line AA', the throttle shall be fully opened as quickly as practically possible and kept in that position until the rear of the vehicle reaches line BB'; the throttle shall then be returned as quickly as possible to the idle position.

For all measurements, the vehicle shall be ridden in a straight line over the acceleration section keeping the median longitudinal plane of the vehicle as close as possible to line CC'.

2.2.4.3.1. In the case of articulated vehicles consisting of two inseparable components and regarded as constituting one single vehicle, the semitrailer shall not be taken into account with regard to the crossing of line BB'.

2.2.4.4. Determining the steady speed to be adopted

2.2.4.4.1. Vehicle without gearbox

The vehicle shall approach line AA' at a steady speed corresponding either to a speed of rotation of the engine equal to three-quarters of that at which the engine develops its maximum power, or to three-quarters of the maximum speed of rotation of the engine permitted by the governor, or 50 km/h, whichever is slowest.

2.2.4.4.2. Vehicle with manual gearbox

If the vehicle is fitted with a gearbox with two, three or four ratios, second gear shall be used. If the gearbox has more than four ratios, third gear shall be used. If the engine then reaches a speed of rotation beyond its maximum power rating, instead of second or third gear the next higher gear to allow line BB' on the test track to be reached without exceeding this rating shall be engaged. Overdrive shall not be selected. If the vehicle has a dual-ratio final drive, the ratio selected shall be that corresponding to the highest speed of the vehicle. The vehicle shall approach line AA' at a steady speed corresponding either to three-quarters of the engine rotation speed at which the engine develops its maximum power, or to three-quarters of the maximum engine rotation speed permitted by the governor, or 50 km/h, whichever is slowest.

2.2.4.4.3. Vehicle with automatic gearbox

The vehicle shall approach line AA' at a steady speed of 50 km/h or three-quarters of its maximum speed, whichever is slower. Where several forward drive positions are available, that producing the highest average acceleration of the vehicle between lines AA' and BB' shall be selected. The selector position that is used only for braking, manoeuvring or similar slow movements shall not be used.

2.2.4.5. For hybrid vehicle, the tests shall be performed twice under the following conditions:

- (a) condition A: batteries shall be at their maximum state of charge; if more than one 'hybrid mode' is available, the most electric hybrid mode shall be selected for the test;

- (b) condition B: batteries shall be at their minimum state of charge; if more than one 'hybrid mode' is available, the most fuel-consuming hybrid mode shall be selected for the test.

2.2.5. Results (test report)

- 2.2.5.1. The test report drawn up for the purpose of issuing the information document according to the template referred to in Article 27(4) of Regulation (EU) No 168/2013 shall indicate any circumstances and influences affecting the results of the measurements.

- 2.2.5.2. The values taken shall be rounded to the nearest decibel.

If the figure following the decimal point is 5, the total is rounded up.

Only measurements which vary by 2.0 dB(A) or less in two consecutive tests on the same side of the vehicle may be used for the purpose of issuing the information document according to the template referred to in Article 27(4) of Regulation (EU) No 168/2013.

- 2.2.5.3. To take account of inaccuracies, 1,0 dB(A) shall be deducted from each value obtained in accordance with point 2.2.5.2.

- 2.2.5.4. If the average of the four measurements does not exceed the maximum permissible level for the category of vehicle in question, the limit laid down in point 2.2.1 will be deemed as being complied with. This average value will constitute the result of the test.

- 2.2.5.5. If the average of four results of Condition A and if this average of four results of Condition B do not exceed the maximum permissible level for the category to which the hybrid vehicle being tested belongs, the limits laid down in point 2.2.1 shall be deemed as being complied with.

The highest average value shall be taken as the result of the test.

2.3. Measurement of the noise of the stationary vehicle (for testing the vehicle in use)

2.3.1. Sound-pressure level in the immediate vicinity of the vehicle

In order to facilitate subsequent noise tests on vehicles in use, the sound-pressure level in the immediate vicinity of the exhaust-system outlet (silencer) shall also be measured in accordance with the following requirements, the measurement being entered in the test report drawn up for the purpose of issuing the document according to the template referred to in Article 32(1) of Regulation (EU) No 168/2013.

2.3.2. Measuring instruments

A precision sound-level meter conforming in accuracy to point 2.2.2.1 shall be used.

2.3.3. Conditions of measurement

2.3.3.1. Condition of the vehicle

Before the measurements are taken, the vehicle engine shall be brought to normal operating temperature. If the vehicle is fitted with fans with an automatic actuating mechanism, this system shall not be interfered with during the noise measurements.

During the measurements, the gearbox shall be in neutral gear. If it is impossible to disconnect the drive train, the driving wheels of the moped or tricycle shall be allowed to rotate freely, e.g. by placing the vehicle on its centre stand or on rollers.

Status: Point in time view as at 16/12/2013.

Changes to legislation: There are currently no known outstanding effects for the Commission Delegated Regulation (EU) No 134/2014. (See end of Document for details)

2.3.3.2. Test site (see Figure Ap3-3)

Any area in which there are no significant acoustic disturbances may be used as a test site. Flat surfaces which are covered with concrete, asphalt or some other hard material and are highly reflective are suitable; surfaces consisting of earth which has been tamped down shall not be used. The test site shall be in the form of a rectangle the sides of which are at least 3 m from the outer edge of the vehicle (handlebars excluded). There shall be no significant obstacles, e.g. no persons other than the rider and the observer may stand within this rectangle.

The vehicle shall be positioned within the rectangle so that the microphone used for measurement is at least 1 m from any kerb.

2.3.3.3. Miscellaneous

Instrument readings caused by ambient noise and wind effects shall be at least 10.0 dB(A) lower than the sound levels to be measured. A suitable windshield may be fitted to the microphone provided that account is taken of its effect on the sensitivity of the microphone.

2.3.4. Method of measurement

2.3.4.1. Nature and number of measurements

The maximum noise level expressed in 1-weighted decibels (dB(A)) shall be measured during the period of operation laid down in point 2.3.4.3.

At least three measurements shall be taken at each measurement point.

2.3.4.2. Positioning of the microphone (Figure Ap3-3)

The microphone shall be positioned level with the exhaust outlet or 0,2 m above the surface of the track, whichever is higher. The microphone diaphragm shall face towards the exhaust outlet at a distance of 0,5 m from it. The axis of maximum sensitivity of the microphone shall be parallel to the surface of the track at an angle of $45^\circ \pm 10^\circ$ to the vertical plane of the direction of the exhaust emissions.

In relation to this vertical plane, the microphone shall be located on the side on which there is the maximum possible distance between the microphone and the outline of the vehicle (handlebars excluded).

If the exhaust system has more than one outlet at centres less than 0,3 m apart, the microphone shall face the outlet which is nearest the vehicle (handlebars excluded) or the outlet which is highest above the surface of the track. If the centres of the outlets are more than 0,3 m apart, separate measurements shall be taken for each of them, the highest figure recorded being taken as the test value.

2.3.4.3. Operating conditions

The engine speed shall be held steady at:

- ((S)/(2)) if S is more than 5 000 rpm,
- ((3S)/(4)) if S is not more than 5 000 rpm,

where S is the engine speed at which maximum power is developed.

When a constant engine speed is reached, the throttle shall be returned swiftly to the idle position. The noise level shall be measured during an operating cycle consisting of a brief period of constant engine speed and throughout the deceleration period, the maximum meter reading being taken as the test value.

Status: Point in time view as at 16/12/2013.

Changes to legislation: There are currently no known outstanding effects for the Commission Delegated Regulation (EU) No 134/2014. (See end of Document for details)

2.3.5. Results (test report)

2.3.5.1. The test report drawn up for the purpose of issuing the information document according to the template referred to in Article 27(4) of Regulation (EU) No 168/2013 shall indicate all relevant data and particularly those used in measuring the noise of the stationary vehicle.

2.3.5.2. Values read off the measuring instrument shall be rounded to the nearest decibel.

If the figure following the decimal point is 5, the total is rounded up.

Only measurements which vary by no more than 2,0 dB(A) in three consecutive tests will be used.

2.3.5.3. The highest of the three measurements shall be taken as the test result.

Figure Ap3-2

Positions for testing the vehicle in motion

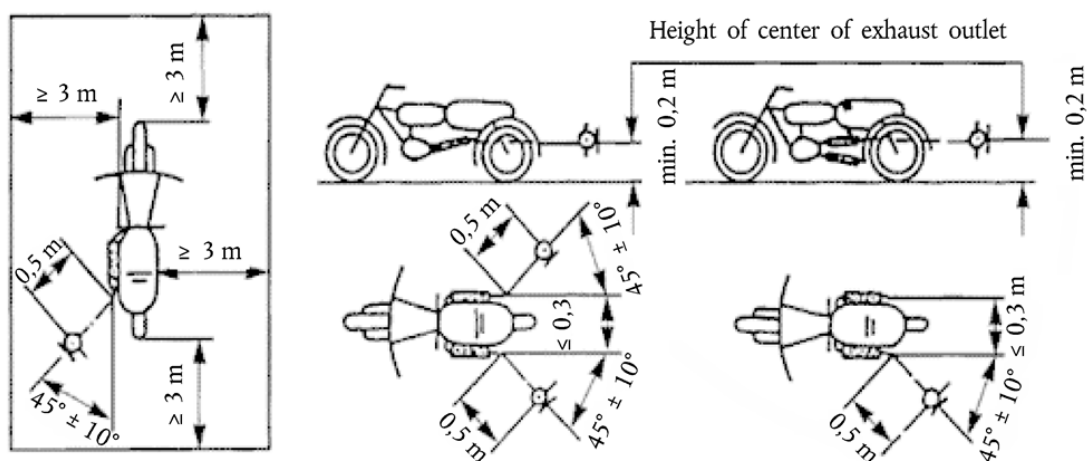
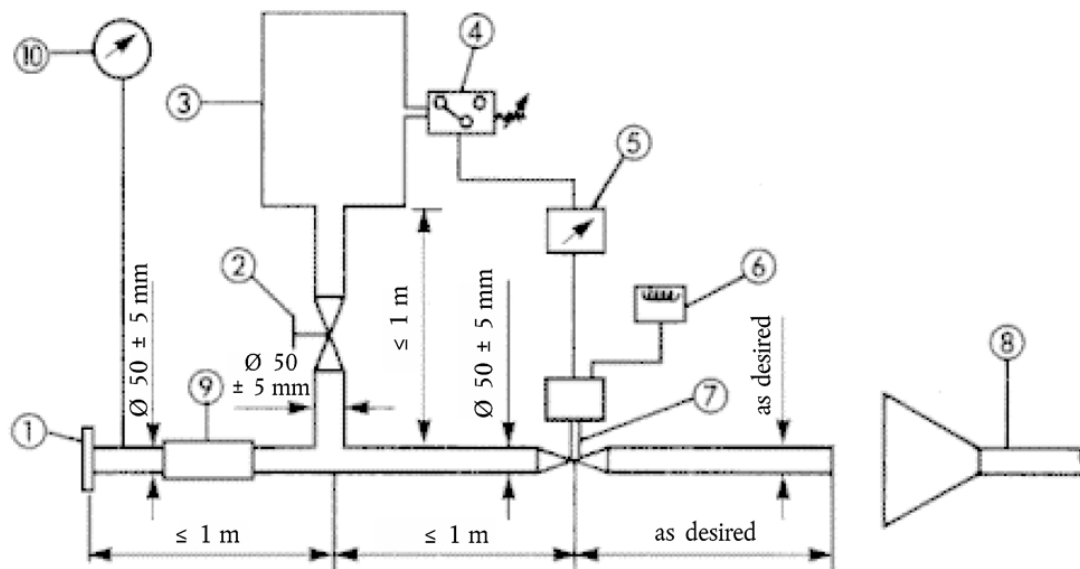

Figure Ap3-3

Status: Point in time view as at 16/12/2013.

Changes to legislation: There are currently no known outstanding effects for the Commission Delegated Regulation (EU) No 134/2014. (See end of Document for details)

Positions for testing the stationary vehicle



2.4. Original exhaust system (silencer)

2.4.1. Requirements for silencers containing absorbent fibrous materials

2.4.1.1. Absorbent fibrous material shall be asbestos-free and may be used in the construction of silencers only if it is held securely in place throughout the service life of the silencer and it meets the requirements of point 2.4.1.2 to 2.4.1.4.

2.4.1.2. After removal of the fibrous material, the sound level shall comply with the requirements of point 2.2.1.

2.4.1.3. The absorbent fibrous material may not be placed in those parts of the silencer through which the exhaust gases pass and shall comply with the following requirements:

2.4.1.3.1. The material shall be heated at a temperature of $650\text{ °C} \pm 5\text{ °C}$ for four hours in a furnace without reduction in the average length, diameter or bulk density of the fibre.

2.4.1.3.2. After being heated at $923,2 \pm 5\text{ K}$ ($650 \pm 5\text{ °C}$) for one hour in a furnace, at least 98 % of the material shall be retained in a sieve of nominal mesh size $250\text{ }\mu\text{m}$ complying with technical standard ISO 3310-1:2000 when tested in accordance with ISO standard 2559:2011.

2.4.1.3.3. The material shall lose no more than 10,5 % of its weight after being soaked for 24 hours at $362,2 \pm 5\text{ K}$ ($90 \pm 5\text{ °C}$) in a synthetic condensate of the following composition:

- 1 N hydrobromic acid (HBr): 10 ml
- 1 N sulphuric acid (H₂SO₄): 10 ml
- distilled water to make up to 1 000 ml.

Note: The material shall be washed in distilled water and dried for one hour at 105 °C before weighing.

2.4.1.4. Before the system is tested it shall be put in normal working order by one of the following methods:

Status: Point in time view as at 16/12/2013.

Changes to legislation: There are currently no known outstanding effects for the Commission Delegated Regulation (EU) No 134/2014. (See end of Document for details)

2.4.1.4.1. Conditioning by continuous road operation

2.4.1.4.1. The table Ap3-1 shows the minimum distance to be travelled for each category of vehicle during conditioning:

Table Ap3-1

Minimum distance to be travelled during conditioning	
Category of vehicle by cylinder capacity(cm³)	Distance(km)
1. ≤ 250	4 000
2. > 250 ≤ 500	6 000
3. > 500	8 000

2.4.1.4.1. 30 % ± 10 % of this conditioning cycle shall consist of town driving and the remainder of long-distance runs at high speed; the continuous road cycle may be replaced by a corresponding test-track programme.

2.4.1.4.1. The two types of driving shall be alternated at least six times.

2.4.1.4.1. The complete test programme shall include at least ten breaks lasting at least three hours in order to reproduce the effects of cooling and condensation.

2.4.1.4.2. Conditioning by pulsation

2.4.1.4.2. The exhaust system or components thereof shall be fitted to the vehicle or to the engine.

In the first case, the vehicle shall be mounted on a roller dynamometer. In the second case, the engine shall be mounted on a test bench.

The test apparatus, as shown in detail in Figure Ap3-4, is fitted at the outlet of the exhaust system. Any other apparatus giving equivalent results is acceptable.

2.4.1.4.2. The test equipment shall be adjusted so that the flow of exhaust gases is alternately interrupted and restored 2 500 times by a rapid-action valve.

2.4.1.4.2. The valve shall open when the exhaust gas back-pressure, measured at least 100 mm downstream of the intake flange, reaches a value of between 0,35 and 0,40 bar. Should the engine characteristics prevent this, the valve shall open when the gas back-pressure reaches a level equivalent to 90 % of the maximum that can be measured before the engine stops. It shall close when this pressure differs by no more than 10 % from its stabilised value with the valve open.

2.4.1.4.2. The time-lapse relay shall be set for the period in which exhaust gases are produced, calculated on the basis of the requirements of point 2.4.1.4.2.3.

2.4.1.4.2. Engine speed shall be 75 % of the speed (S) at which the engine develops maximum power.

2.4.1.4.2. The power indicated by the dynamometer shall be 50 % of the full-throttle power measured at 75 % of engine speed (S).

Status: Point in time view as at 16/12/2013.

Changes to legislation: There are currently no known outstanding effects for the Commission Delegated Regulation (EU) No 134/2014. (See end of Document for details)

2.4.1.4.2. Any drainage holes shall be closed off during the test.

2.4.1.4.2. The entire test shall be completed within 48 hours. If necessary, a cooling period shall be allowed after each hour.

2.4.1.4.3. Conditioning on a test bench

2.4.1.4.3. The exhaust system shall be fitted to an engine representative of the type fitted to the vehicle for which the system is designed and mounted on a test bench.

2.4.1.4.3. Conditioning consists of the specified number of test-bench cycles for the category of vehicle for which the exhaust system was designed. The table shows the number of cycles for each category of vehicle.

Table Ap3-2

Number of conditioning cycles	
Category of vehicle by cylinder capacity(cm ³)	Number of cycles
1. ≤ 250	6
2. > 250 ≤ 500	9
3. > 500	12

2.4.1.4.3. Each test-bench cycle shall be followed by a break of at least six hours in order to reproduce the effects of cooling and condensation.

2.4.1.4.3. Each test-bench cycle consists of six phases. The engine conditions and duration are as follows for each phase:

Table Ap3-3

Duration of test phases			
Phase	Conditions	Duration of phase(minutes)	
1	Idling	6	6
2	25 % load at 75 % S	40	50
3	50 % load at 75 % S	40	50
4	100 % load at 75 % S	30	10
5	50 % load at 100 % S	12	12
6	25 % load at 100 % S	22	22
Total time:		2 hrs. 30 mins	2 hrs. 30 mins

2.4.1.4.3. During this conditioning procedure, at the request of the manufacturer, the engine and the silencer may be cooled so that the temperature recorded at a point not more than 100 mm from the exhaust gas outlet does not exceed that measured when the vehicle

Status: Point in time view as at 16/12/2013.

Changes to legislation: There are currently no known outstanding effects for the Commission Delegated Regulation (EU) No 134/2014. (See end of Document for details)

is running at 110 km/h or 75 % S in top gear. The engine or vehicle speeds shall be determined with an accuracy of ± 3 %.

Figure Ap3-4

Test apparatus for conditioning by pulsation

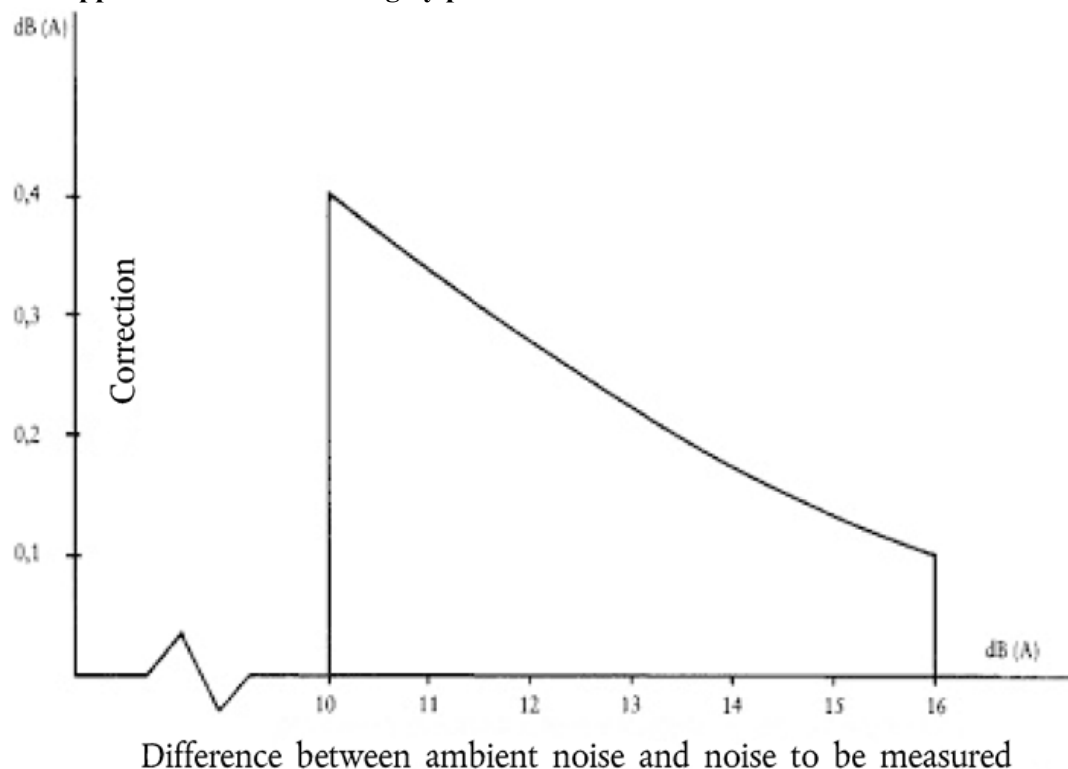

2.4.2. Diagram and markings

2.4.2.1. A diagram and a cross-sectional drawing indicating the dimensions of the exhaust system shall be attached to the information document according to the template referred to in Article 27(4) of Regulation (EU) No 168/2013.

2.4.2.2. All original silencers shall bear at least the following:

- the 'e' mark followed by the reference to the country which granted the type-approval;
- the vehicle manufacturer's name or trademark; and
- the make and identifying part number.

This reference shall be legible, indelible and visible in the position at which it is to be fitted.

2.4.2.3. Any packing of original replacement silencer systems shall be marked legibly with the words 'original part' and the make and type references linked with the 'e' mark and also the reference to the country of origin.

2.4.3. Intake silencer

If the engine intake has to be fitted with an air filter or intake silencer in order to comply with the permissible noise level, the filter or silencer shall be regarded as part of the silencer and the requirements of point 2.4 will also apply to them.

Status: Point in time view as at 16/12/2013.

Changes to legislation: There are currently no known outstanding effects for the Commission Delegated Regulation (EU) No 134/2014. (See end of Document for details)

3. **Component type-approval in respect of a non-original exhaust system or components thereof, as separate technical units, for three-wheel mopeds and tricycles**

This section applies to the component type-approval, as separate technical units, of exhaust systems or components thereof intended to be fitted to one or more particular types of three-wheel mopeds and tricycles as non-original replacement parts.

3.1. Definition

3.1.1. ‘Non-original replacement exhaust system or components thereof’ means any exhaust system component as defined in point 1.2 intended to be fitted to a three- moped, tricycle or quadricycle to replace that of the type fitted to the three-wheel moped, tricycle or quadricycle when the information document according to the template referred to in Article 27(4) Regulation (EU) No 168/2013 was issued.

3.2. Application for component type-approval

3.2.1. Applications for component type-approval for replacement exhaust systems or components thereof as separate technical units shall be submitted by the manufacturer of the system or by his authorised representative.

3.2.2. For each type of replacement exhaust system or components thereof for which approval is requested, the application for component type-approval shall be accompanied by the following documents in triplicate, and by the following particulars:

3.2.2.1. description, in respect of the characteristics referred to in point 1.1, of the types of vehicle for which the systems or components are intended; the numbers or symbols specific to the type of engine and vehicle shall be given;

3.2.2.2. description of the replacement exhaust system stating the relative positions of each of its components, together with the fitting instructions;

3.2.2.3. drawings of each component to facilitate location and identification, and statement of materials used. These drawings shall also indicate the intended location of the mandatory component type-approval mark.

3.2.3. At the request of the technical service, the applicant shall submit:

3.2.3.1. two samples of the system for which component type-approval is requested;

3.2.3.2. an exhaust system conforming to that originally fitted to the vehicle when the information document according to the template referred to in Article 27(4) of Regulation (EU) No 168/2013 was issued;

3.2.3.3. a vehicle representative of the type to which the replacement exhaust system is to be fitted, supplied in such a condition that, when fitted with a silencer of the same type as was originally fitted, it meets the requirements of either of the following two sections:

3.2.3.3.1. if the vehicle is of a type which has been granted type-approval pursuant to the provisions of this Appendix:

during the test in motion, it may not exceed by more than 1.0 dB(A) the limit value laid down in point 2.2.1.3;

Status: Point in time view as at 16/12/2013.

Changes to legislation: There are currently no known outstanding effects for the Commission Delegated Regulation (EU) No 134/2014. (See end of Document for details)

during the stationary test, is may not exceed by more than 3.0 dB(A) the value indicated on the manufacturer's statutory plate;

3.2.3.3.2. if the vehicle is not of a type which has been granted type-approval pursuant to the provisions of this Appendix, it may not exceed by more than 1.0 dB(A) the limit value applicable to that type of vehicle when it first entered into service;

3.2.3.4. a separate engine identical to that fitted to the vehicle referred to in point 3.2.3.3., should the approval authorities deem it necessary.

3.3. Markings and inscriptions

3.3.1. Non-original exhaust systems or components thereof shall be marked in accordance with the requirements of Article 39 of Regulation (EU) No 168/2013.

3.4. Component type-approval

3.4.1. Upon completion of the tests laid down in this Appendix, the approval authority shall issue a certificate corresponding to the model referred to in Article 30(2) of Regulation (EU) No 168/2013. The component type-approval number shall be preceded by a rectangle surrounding the letter 'e' followed by the distinguishing number or letters of the Member State which issued or refused the component type-approval.

3.5. Specifications

3.5.1. General specifications

The design, construction and mounting of the silencer shall be such that:

3.5.1.1. the vehicle complies with the requirements of the Appendix under normal conditions or use, and in particular regardless of any vibrations to which it may be subjected;

3.5.1.2. it displays reasonable resistance to the corrosion phenomena to which it is exposed, with due regard to normal conditions of use;

3.5.1.3. the ground clearance under the silencer as originally fitted, and the angle at which the vehicle can lean over, are not reduced;

3.5.1.4. the surface does not reach unduly high temperatures;

3.5.1.5. its outline has no projections or sharp edges;

3.5.1.6. shock absorbers and suspension have adequate clearance;

3.5.1.7. adequate safety clearance is provided for pipes;

3.5.1.8. it is impact-resistant in a way that is compatible with clearly-defined maintenance and installation requirements.

3.5.2. Specifications for noise levels

3.5.2.1. The acoustic efficiency of the replacement exhaust systems or components thereof shall be tested using the methods described in points 2.3 and 2.4.

With a replacement exhaust system or component thereof fitted to the vehicle referred to in point 3.2.3.3 of this Appendix, the noise-level values obtained shall meet the following conditions:

Status: Point in time view as at 16/12/2013.

Changes to legislation: There are currently no known outstanding effects for the Commission Delegated Regulation (EU) No 134/2014. (See end of Document for details)

3.5.2.1.1. they shall not exceed the noise-level values measured, in accordance with point 3.2.3.3, using the same vehicle fitted with the original equipment silencer both during the test in motion and during the stationary test.

3.5.3. Testing of vehicle performance

3.5.3.1. The replacement silencer shall be such as to ensure that the performance of the vehicle is comparable with that achieved with the original silencer or component thereof.

3.5.3.2. The replacement silencer shall be compared with an originally-fitted silencer, also in new condition, fitted to the vehicle referred to in point 3.2.3.3.

3.5.3.3. This test is carried out by measuring the engine power curve. The net maximum power and the top speed measurements with the replacement silencer shall not deviate by more than ± 5 % from those taken under the same conditions with the original equipment silencer.

3.5.4. Additional provisions relating to silencers as separate technical units containing fibrous material

Fibrous material may not be used in the construction of such silencers unless the requirements set out in point 2.4.1 are met.

3.5.5. Evaluation of the pollutant emissions of vehicles equipped with a replacement silencer system.

The vehicle referred to in point 3.2.3.3, equipped with a silencer of the type for which approval is requested, shall undergo a type I, II and V test under the conditions described in the corresponding Annexes to this Regulation according to the type-approval of the vehicle.

The requirements regarding emissions shall be deemed to be fulfilled if the results are within the limit values according to the type-approval of the vehicle

Appendix 4

Test track specification

0. Introduction

This Appendix lays down specifications relating to the physical characteristics and the layout of the test track paving.

1. Required characteristics of surface

A surface is considered to conform to this Regulation if its texture and void content or noise absorption coefficient have been measured and found to fulfil the requirements of points 1.1 to 1.4 and the design requirements (point 2.2) have been met.

1.1. Residual void content

The residual void content, V_c , of the test track paving mixture shall not exceed 8 %. The measurement procedure is set out in point 3.1.

1.2. Noise absorption coefficient

If the surface fails to comply with the residual void content requirement, it is acceptable only if its noise absorption coefficient, $\alpha \leq 0,10$. The measurement procedure is set out in point 3.2.

The requirement of points 1.1 and 1.2 is also met if only noise absorption has been measured and found to be: $\alpha \leq 0,10$.

1.3. Texture depth

The texture depth (TD) measured according to the volumetric method (see point 3.3) shall be:

$TD \geq 0,4$ mm.

1.4. Homogeneity of the surface

Every practical effort shall be made to ensure that the surface is as homogenous as possible within the test area. This includes the texture and void content, but it shall be noted that if the rolling process results in more effective rolling in some places than others, the texture may be different and unevenness causing bumps may occur.

1.5. Period of testing

In order to check whether the surface continues to conform to the texture and void content or noise absorption requirements of this specification, periodic testing of the surface shall be performed at the following intervals:

- (a) for residual void content or noise absorption:
 - when the surface is new; if the surface meets the requirements when new, no further periodical testing is required,
 - if the surface does not meet the requirement when new, it may do so subsequently because surfaces tend to become clogged and compacted with time;
- (b) for texture depth (TD):
 - when the surface is new,
 - when the noise testing starts (NB at least four weeks after laying),

Status: Point in time view as at 16/12/2013.

Changes to legislation: There are currently no known outstanding effects for the Commission Delegated Regulation (EU) No 134/2014. (See end of Document for details)

— every twelve months thereafter.

2. Test surface design

2.1. Area

When designing the test track layout, it is important to ensure that, as a minimum requirement, the area traversed by the vehicles running through the test strip is covered with the specified test material with suitable margins for safe and practical driving. This will require that the width of the track is at least 3 m and the length of the track extends beyond lines AA and BB by at least 10 m at either end. Figure Ap4-1 shows a plan of a suitable test site and indicates the minimum area which shall be machine-laid and machine-compacted with the specified test surface material.

Figure Ap4-1

Minimum requirements for test surface area

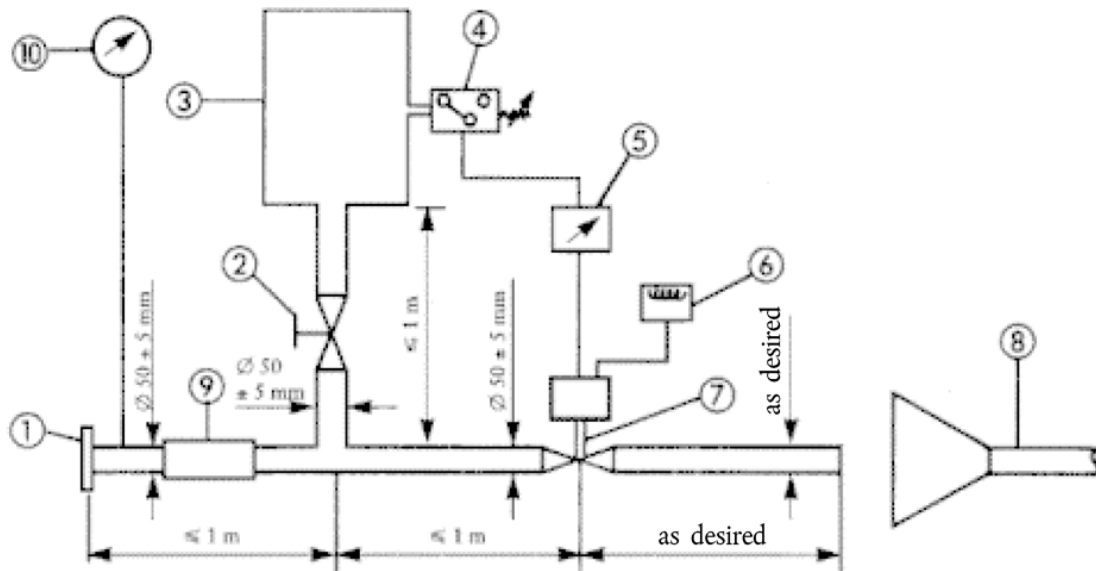

2.2. Design requirements for the surface

The test surface shall meet four design requirements:

- it shall be a dense asphaltic concrete;
- the maximum chipping size shall be 8 mm (tolerances allow from 6.3 to 10 mm);
- the thickness of the wearing course shall be ≥ 30 mm;
- the binder shall be a straight penetration-grade bitumen without modification.

As a guide to the test surface constructor, an aggregate grading curve which will give the desired characteristics is shown in Figure Ap4-2. In addition, Table Ap4-1 gives guidelines for obtaining the desired texture and durability. The grading curve fits the following formula:

Equation Ap4-1:

$$P(\% \text{ passing}) = 100(d / d_{\max})^2$$

where:

Status: Point in time view as at 16/12/2013.

Changes to legislation: There are currently no known outstanding effects for the Commission Delegated Regulation (EU) No 134/2014. (See end of Document for details)

d	square mesh sieve size, in mm
d _{max}	8 mm for the mean curve
d _{max}	10 mm for the lower tolerance curve
d _{max}	6,3 mm for the upper tolerance curve

In addition:

- the sand fraction (0,063 mm < square mesh sieve size < 2 mm) shall include no more than 55 % natural sand and least 45 % crushed sand,
- the base and sub-base shall ensure good stability and evenness, according to best road construction practice,
- the chippings shall be crushed (100 % crushed faces) and of a material with a high resistance to crushing,
- the chippings used in the mix should be washed,
- no extra chippings shall be added onto the surface,
- the binder hardness expressed as PEN value shall be 40 to 60, 60 to 80 or 80 to 100, depending on climatic conditions. As hard a binder as possible shall be used, provided this is consistent with common practice,
- the temperature of the mix before rolling shall be such as to achieve the required void content by subsequent rolling. In order to satisfy the specifications of points 1.1 to 1.4 as regards compactness, attention shall be paid to an appropriate choice of mixing temperature, an appropriate number of passes and the choice of compacting vehicle.

Figure Ap4-2

Grading curve of the aggregate in the asphaltic mix, with tolerances

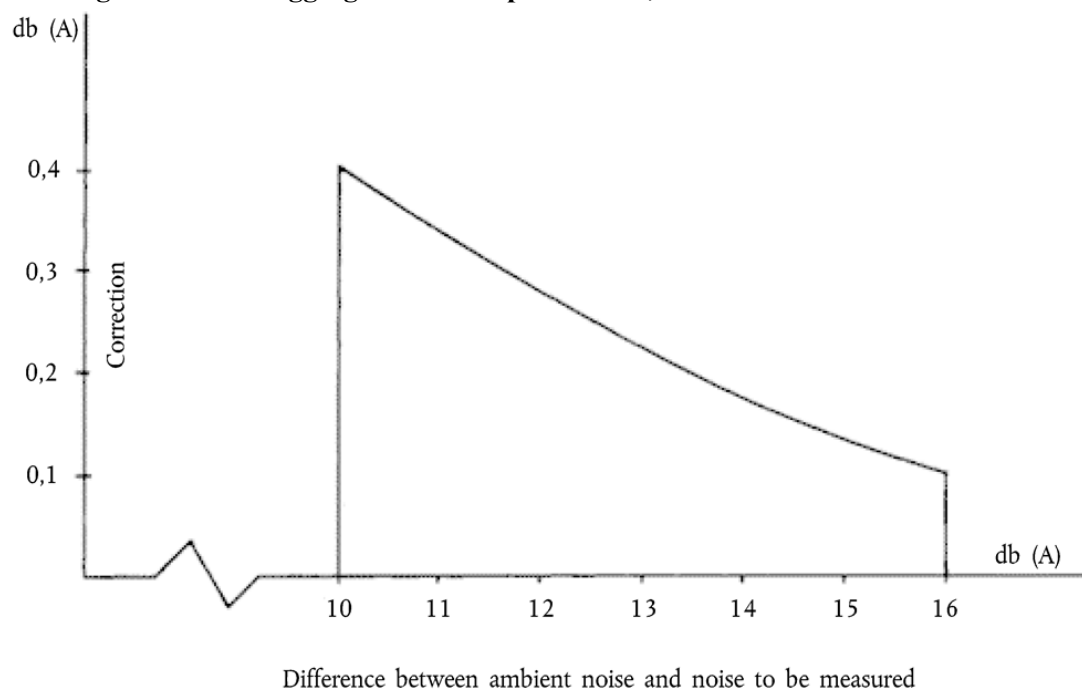

TABLE AP4-1

Design guidelines

Status: Point in time view as at 16/12/2013.

Changes to legislation: There are currently no known outstanding effects for the Commission Delegated Regulation (EU) No 134/2014. (See end of Document for details)

	Target values		Tolerances
	By total mass of mix	By mass of the appropcase	
Mass of stones, square mesh sieve (SM) > 2 mm	47,6 %	50,5 %	± 5
Mass of sand 0,063 < SM < 2 mm	38,0 %	40,2 %	± 5
Mass of filter SM < 0,063 mm	8,8 %	9,3 %	± 2
Mass of binder (bitumen)	5,8 %	N.A.	± 0,5
Maximum chipping size	8 mm		6,3-10
Binder hardness	(see below)		
Polished stone value (PSV)	> 50		
Compactness, relative to Marshall compactness	98 %		

3. Test methods

3.1 Measurement of the residual void content

For the purpose of this measurement, cores are taken from at least four different points of the track which are equally distributed in the test area between lines AA and BB (see Figure Ap4-1). In order to avoid creating a lack of homogeneity and unevenness in the wheel tracks, cores shall not be taken in the tracks themselves, but close to them. At least two cores shall be taken close to the wheel tracks and at least one approximately midway between the tracks and each microphone location.

If there is a suspicion that the homogeneity requirement is not met (see point 1.4), cores shall be taken from more points in the test area.

The residual void content must be determined for each core. The average value for all cores is calculated and compared with the requirement of point 1.1. In addition, no single core shall have a void value of over 10 %.

The test surface constructor is reminded that problems may arise where the test area is heated by pipes or electrical wires. Cores shall be taken from this area and such installations shall be carefully planned with respect to future core drilling locations. It is recommended that a few areas of approximately 200 × 300 mm be left where there are no wires or pipes, or where the latter are located deep enough not to be damaged by cores taken from the surface layer.

3.2. Noise absorption coefficient

The noise absorption coefficient (normal incidence) is measured by the impedance tube method using the procedure specified in ISO 10534-1:1996: 'Determination of sound absorption coefficient and impedance in impedance tubes – Part 1: Method using standing wave ratio'.

The same requirements apply to test specimens as to residual void content (see point 3.1).

The noise absorption is measured in the range 400 to 800 Hz and in the range 800 to 1 600 Hz (at least at the centre frequencies of third octave bands) and the maximum values shall be identified for both of these frequency ranges. The values for all test scores are averaged to constitute the final result.

3.3. Volumetric macro texture measurement

Texture depth measurements are taken from at least ten points evenly spaced along the wheel tracks of the test strip and the average value is compared with the specified minimum texture depth. See Annex F to ISO 10844:2011 for a description of the procedure.

4. Stability in time and maintenance

4.1. Age influence

It is expected that the tyre/road noise levels measured on the test surface may increase slightly in the first 6 to 12 months after construction.

The surface will achieve its required characteristics at least four weeks after construction.

Stability over time is determined mainly by the polishing and compaction caused by vehicles driving on the surface. It shall be periodically checked as stated in point 1.5.

4.2. Maintenance of the surface.

Loose debris or dust which could significantly reduce the effective texture depth shall be removed from the surface. Salt may alter the surface temporarily or even permanently in such a way as to increase noise and it is therefore not recommended that it be used for de-icing.

4.3. Repaving the test area

It is not necessary to repave more than the test strip (3 m wide in Figure Ap4-1) where vehicles are driving provided the area outside the strip met the residual void content or noise absorption requirements when it was measured.

5. Documentation of the surface and of tests performed on it

5.1. Documentation of the test surface

The following data shall be given in a document describing the test surface:

- (a) the location of the test track;
- (b) type of binder, binder hardness, type of aggregate, maximum theoretical density of the concrete ('DR'), thickness of the wearing course and grading curve determined from cores from the test track;
- (c) method of compaction (e.g. type of roller, roller mass, number of passes);
- (d) temperature of the mix, temperature of the ambient air and wind speed during laying of the surface;
- (e) date when the surface was laid and identity of contractor;
- (f) all, or at least the latest, test results, including:
 - (i) the residual void content of each core;
 - (ii) the locations in the test area from which the cores for void measurement were taken;

Status: Point in time view as at 16/12/2013.

Changes to legislation: There are currently no known outstanding effects for the Commission Delegated Regulation (EU) No 134/2014. (See end of Document for details)

- (iii) the noise absorption coefficient of each core (if measured), specifying the results both for each core and each frequency range as well as the overall average;
- (iv) the locations in the test area from which the cores for absorption measurement were taken;
- (v) texture depth, including the number of tests and standard deviation;
- (vi) the institution responsible for tests (i) and (iii) and the type of equipment used;
- (vii) date of the test(s) and date when the cores were taken from the test track.

5.2. Documentation of vehicle noise tests

In the document describing the vehicle noise test(s), it shall be stated whether all the requirements were fulfilled or not. Reference shall be made to a document in accordance with point 5.1.

Status: Point in time view as at 16/12/2013.

Changes to legislation: There are currently no known outstanding effects for the Commission Delegated Regulation (EU) No 134/2014. (See end of Document for details)

ANNEX X

Testing procedures and technical requirements as regards propulsion unit performance

Appendix Number	Appendix title	Page
1.	Requirements concerning the method for measuring the maximum design vehicle speed	289
1.1	Procedure for defining the correction coefficient for the annular vehicle speed-test track	293
2.	Requirements concerning the methods for measuring the maximum torque and maximum net power of a propulsion containing a combustion engine or a hybrid propulsion type	294
2.1	Determination of the maximum torque and maximum net power of spark-ignition engines for vehicle categories L1e, L2e and L6e	295
2.2	Determination of the maximum torque and maximum net power of spark-ignition engines for vehicle categories L3e, L4e, L5e and L7e	301
2.2.1.	Measurement of maximum torque and maximum net engine power by means of the engine-temperature method	307
2.3.	Determination of the maximum torque and maximum net power of L-category vehicles equipped with a compression ignition engine	308
2.4.	Determination of the maximum torque and maximum power of L-category vehicles equipped with a hybrid propulsion	315

Status: Point in time view as at 16/12/2013.

Changes to legislation: There are currently no known outstanding effects for the Commission Delegated Regulation (EU) No 134/2014. (See end of Document for details)

3.	Requirements concerning the methods for measuring the maximum torque and maximum continuous rated power of a pure electric propulsion type	316
4.	Requirements concerning the method for measuring the maximum continuous rated power, switch-off distance and maximum assistance factor of an L1e category vehicle designed to pedal referred to in Article 3(94b) of Regulation (EU) No 168/2013	317

1. Introduction

- 1.1. In this Annex requirements are set out with regard to the output performance of the propulsion units of L-category vehicles, in particular with regard to measurement of the maximum design vehicle speed, the maximum torque, the maximum net power or maximum continuous rated power. In addition for L1e category vehicles designed to pedal specific requirements are set out to determine the switch-off distance and maximum assistance factor of the propulsion units.
- 1.2. The requirements are custom tailored for L-category vehicles equipped with propulsion units referred to in Article 4(3) of Regulation (EU) No 168/2013.

2. Test procedures

The test procedures set out in appendices 1 to 4 shall be used for the type-approval of L-category vehicles.

Appendix 1

Requirements concerning the method for measuring the maximum design vehicle speed

1. Scope

Measurement of the maximum design vehicle speed is obligatory for L-category vehicles that are limited in maximum design vehicle speed in accordance with Annex I to Regulation (EU) No 168/2013, which concerns (sub-)categories L1e, L2e, L6e and L7e-B1 and L7e-C.

2. Test vehicle

2.1. The test vehicles used for propulsion unit performance tests shall be representative of the vehicle type with regard to the propulsion unit performance produced in series and placed on the market.

2.2. Preparation of the test vehicle

2.2.1. The test vehicle shall be clean and only those accessories needed to enable the vehicle to undergo the test shall be in operation.

2.2.2. The fuel-supply and the ignition settings, the viscosity of the lubricants for the mechanical parts in motion, and the tyre pressures shall be as required by the manufacturer.

2.2.3. The engine, drive train and tyres of the test vehicle shall have been properly run-in in accordance with the manufacturer's requirements.

2.2.4. Before the test, all parts of the test vehicle shall be in a thermally stable state, at their normal operating temperature.

2.2.5. The test vehicle shall be submitted at its mass in running order.

2.2.6. The distribution of the loadings across the wheels of the test vehicle shall be as intended by the manufacturer.

3. Driver

3.1. Uncabbed vehicle

3.1.1. The driver shall have a mass of $75 \text{ kg} \pm 5 \text{ kg}$ and be $1,75 \text{ m} \pm 0,05 \text{ m}$ tall. For mopeds, these tolerances are reduced to $\pm 2 \text{ kg}$ and $\pm 0,02 \text{ m}$ respectively.

3.1.2. The driver shall wear an adjusted one-piece suit or equivalent item of clothing.

3.1.3. The driver shall be seated on the driver's seat with his feet on the pedals or footrest and his arms extended normally. Where vehicles achieve a maximum speed of more than 120 km/h when their rider is in a seated position, the rider shall be equipped and positioned as recommended by the manufacturer and shall be in full control of the vehicle throughout the test. The driving position shall be the same throughout the test and described or represented by photographs in the test report.

3.2. Cabbed vehicle

3.2.1. The driver shall have a mass of $75 \text{ kg} \pm 5 \text{ kg}$. For mopeds, this tolerance is reduced to $\pm 2 \text{ kg}$.

4. Characteristics of the test track

Status: Point in time view as at 16/12/2013.

Changes to legislation: There are currently no known outstanding effects for the Commission Delegated Regulation (EU) No 134/2014. (See end of Document for details)

- 4.1. The tests shall be carried out on a road:
- 4.1.1. which allows the maximum vehicle speed to be maintained along a measurement base as defined in point 4.2. The acceleration track preceding the measuring base shall be of the same type (surface and longitudinal profile) and be sufficiently long for the vehicle to reach its maximum speed;
- 4.1.2. that is clean, smooth, dry and asphalted or surfaced in an equivalent manner;
- 4.1.3. having a longitudinal gradient of not more than 1 % and a degree of banking of not more than 3 %. The variation in altitude between any two points on the test base shall not exceed 1 m.
- 4.2. The possible configurations for the measuring base are illustrated in points 4.2.1., 4.2.2. and 4.2.3.

- 4.2.1. *Figure Ap1-1*

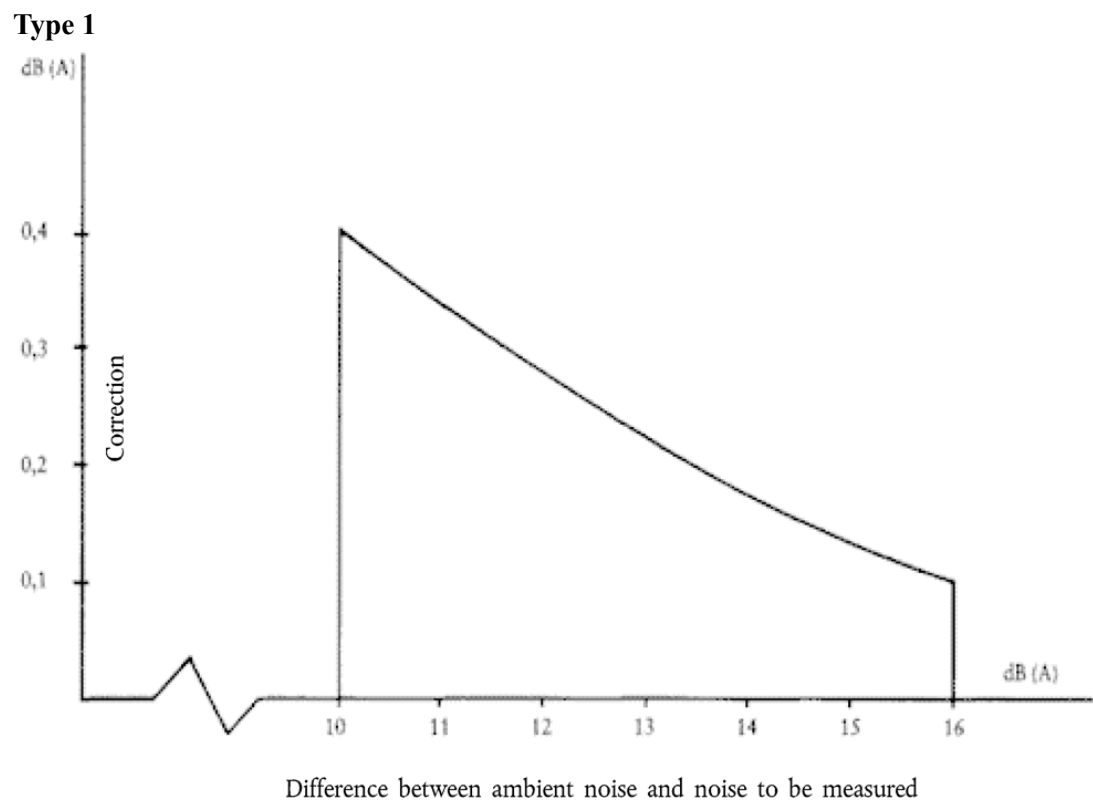

- 4.2.2. *Figure Ap1-2*

Status: Point in time view as at 16/12/2013.

Changes to legislation: There are currently no known outstanding effects for the Commission Delegated Regulation (EU) No 134/2014. (See end of Document for details)

Type 2

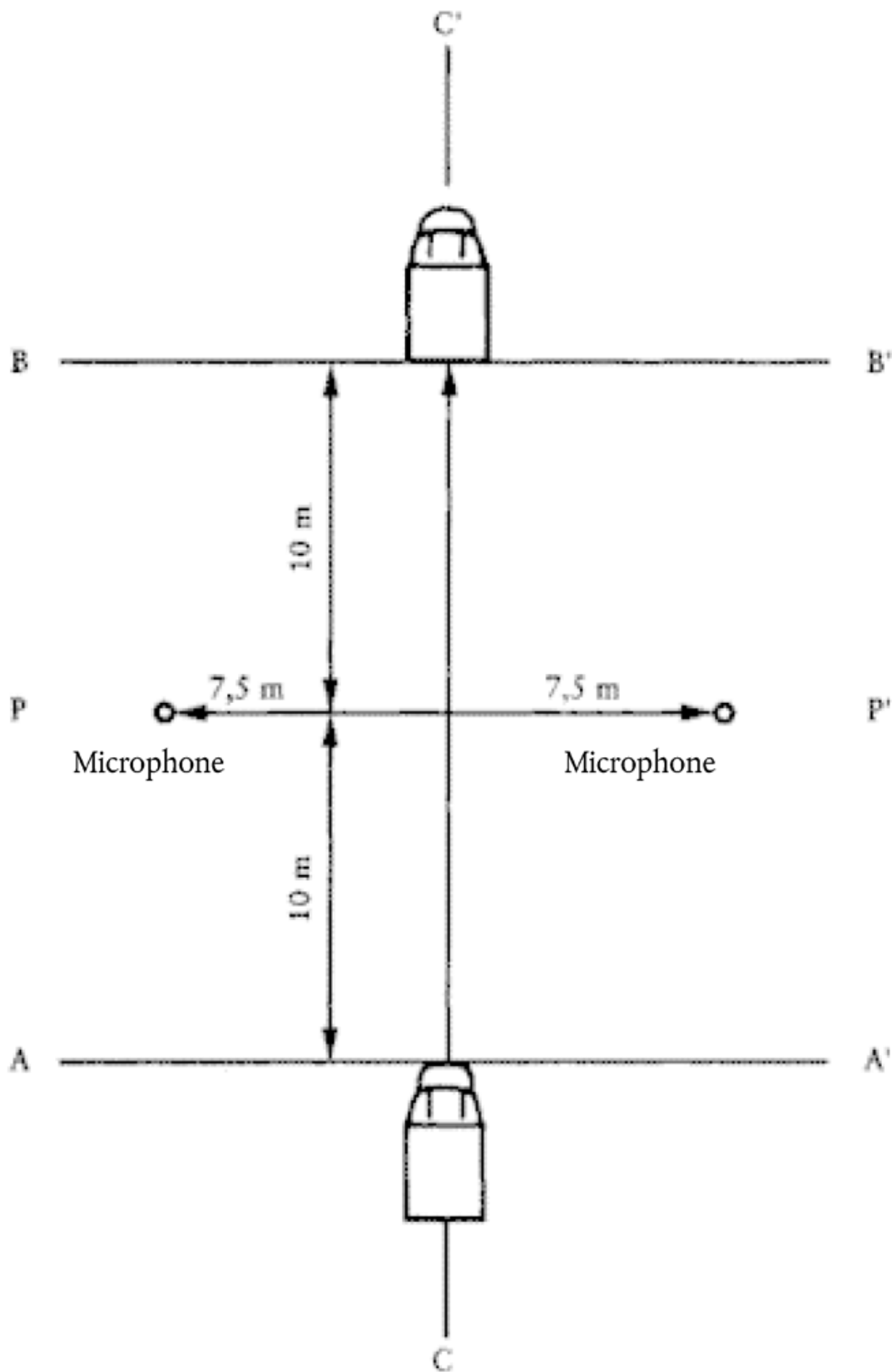

Status: Point in time view as at 16/12/2013.

Changes to legislation: There are currently no known outstanding effects for the Commission Delegated Regulation (EU) No 134/2014. (See end of Document for details)

4.2.3. Figure Ap1-3

Type 3

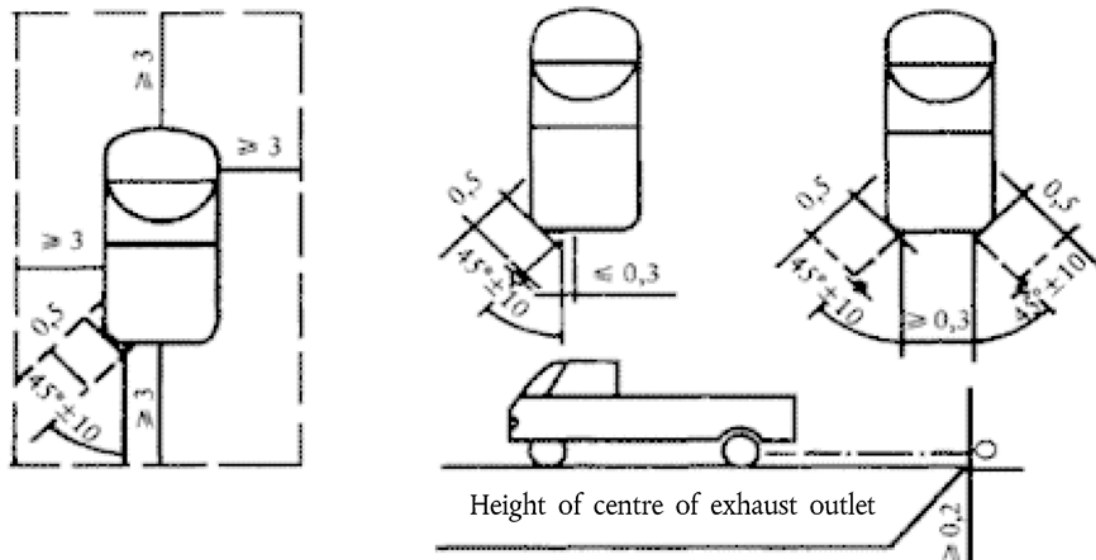

- 4.2.3.1. The two measuring bases L shall be equal in length and virtually parallel to each other.
- 4.2.3.2. If both measuring bases are curvilinear in shape despite the requirements of point 4.1.3., the effects of centrifugal force shall be compensated for by the cross-section of the bends.
- 4.2.3.3. Instead of the two bases L (see point 4.2.3.1.), the measuring base may coincide with the overall length of the annular test track. In this case, the minimum radius of the bends shall be 200 m and the effects of centrifugal force compensated for by the cross-section of the bends.
- 4.3. Length L of the measuring base shall be selected in conjunction with the accuracy of the equipment and the methods used to measure testing time t so that the value for actual vehicle speed can be plotted to within $\pm 1\%$. If the measuring equipment is of the manual type, length L of the measuring base shall not be less than 500 m. If a type 2 measuring base has been selected, electronic measuring equipment shall be used in order to determine time t.
5. **Atmospheric conditions**
 Atmospheric pressure: 97 ± 10 kPa.
 Ambient temperature: between 278,2 K and 318,2 K.
 Relative humidity: 30 to 90 %.
 Average wind speed, measured 1 m above the ground: < 3 m/s, permitting gusts of < 5 m/s.
6. **Test procedures**
- 6.1. L1e vehicles equipped with power-controlled pedal assistance shall be tested according to the test procedure set out in point 4.2.6 of EN 15194:2009, on the maximum speed of a vehicle assisted by an electric motor. If the L1e vehicle is tested according to that test procedure, points 6.2 to 6.9. may be omitted.

Status: Point in time view as at 16/12/2013.

Changes to legislation: There are currently no known outstanding effects for the Commission Delegated Regulation (EU) No 134/2014. (See end of Document for details)

- 6.2. The gear ratio used during the test shall enable the vehicle to reach its maximum vehicle speed on level ground. The throttle control shall be kept fully open and any user-selectable propulsion operation mode shall be activated so as to deploy maximum propulsion unit performance.
- 6.3. Drivers of uncabbed vehicles shall maintain their driving position as defined in point 3.1.3.
- 6.4. The vehicle shall arrive at the measuring base at a constant vehicle speed. Type 1 and type 2 bases shall be travelled along in both directions in succession.
- 6.4.1. Testing in a single direction may be accepted on a type 2 measuring base if, owing to the characteristics of the circuit, it is not possible to reach the maximum speed of the vehicle in both directions. In this case:
- 6.4.1.1. the test run shall be repeated five times in immediate succession;
- 6.4.1.2. the speed of the axial wind component shall not exceed 1 m/s.
- 6.5. Both bases L on a type 3 measuring base shall be travelled along consecutively in a single direction, without interruption.
- 6.5.1. If the measuring base coincides with the total length of the circuit, it shall be travelled along in a single direction at least twice. The difference between the extremes of the time measurements shall not exceed 3 %.
- 6.6. The fuel and lubricant shall be those recommended by the manufacturer.
- 6.7. The total time t needed to travel along the measuring base in both directions shall be determined to an accuracy of 0,7 %.

6.8. Determination of average speed

Average speed V (km/h) for the test is determined as follows:

6.8.1. Type 1 and type 2 measuring base

Equation Ap1-1:

$$v = \frac{3,6 \times 2 \times L}{t} = \frac{7,2 \times L}{t}$$

where:

- L = length of measuring base (m)
 t = time (s) taken to travel along measuring base L (m).

6.8.2. Type 2 measuring base, travelled along in a single direction

Equation Ap1-2:

$$v = v_a$$

where:

Equation Ap1-3:

$$v_a = \text{vehicle speed measured for each test run (km/h)} = v = \frac{3,6 \times L}{t}$$

where:

- L = length of measuring base (m)
 t = time (s) taken to travel along measuring base L (m).

Status: Point in time view as at 16/12/2013.

Changes to legislation: There are currently no known outstanding effects for the Commission Delegated Regulation (EU) No 134/2014. (See end of Document for details)

6.8.3. Type 3 measuring base

6.8.3.1. Measuring base consisting of two parts L (see point 4.2.3.1.)

Equation Ap1-4:

$$v = \frac{3,6 \times 2 \times L}{t} = \frac{7,2 \times L}{t}$$

where:

- L = length of measuring base (m)
 t = total time (s) needed to travel along both measuring bases L (m).

6.8.3.2. Measuring base coinciding with the total length of the annular test track (see point 3.1.4.2.3.3)

Equation Ap1-5:

$$v = v_a \times k$$

where:

Equation Ap1-6:

$$v_a = \text{vehicle speed measured (km/h)} = v = \frac{3,6 \times L}{t}$$

where:

- L = length of trajectory actually followed on the annular speed-test track (m)
 t = time (s) needed to complete a full lap

Equation Ap1-7:

$$t = \frac{1}{n} \times \sum_{i=1}^n t_i$$

where:

- n = number of laps
 t_i = time (s) needed to complete each lap
 k = correction factor (1,00 ≤ 1,05); this factor is specific to the annular test track used and is determined experimentally in line with Appendix 1.1.

6.9. The average speed shall be measured at least twice in succession.

7. Maximum vehicle speed

The maximum vehicle speed of the test vehicle shall be expressed in kilometres per hour by the figure corresponding to the closest whole number to the arithmetical mean of the values for the vehicle speeds measured during the two consecutive tests, which shall not diverge by more than 3 %. If this arithmetical mean lies exactly between two whole numbers, it shall be rounded up to the next highest number.

8. Maximum vehicle speed measurement tolerances

8.1. The maximum vehicle speed, as determined by the technical service to the satisfaction of the approval authority, may differ from the value in point 7 by ± 5 %.

Appendix 1.1

Procedure for defining the correction coefficient for the annular vehicle speed-test track

1. Coefficient k relating to the annular test track shall be plotted up to the maximum permitted vehicle speed.
2. Coefficient k shall be plotted for several vehicle speeds in such a way that the difference between two consecutive vehicle speeds will not be more than 30 km/h.
3. For each vehicle speed selected, the test shall be carried out in line with the requirements of this Regulation, in two ways:
 - 3.1. Vehicle speed measured in a straight line v_d .
 - 3.2. Vehicle speed measured on the annular test track v_a .
4. For each vehicle speed measured, values v_a and v_d shall be entered on a diagram similar to that in Figure Ap1.1-1, with the successive points linked by a segment of a straight line.

Status: Point in time view as at 16/12/2013.

Changes to legislation: There are currently no known outstanding effects for the Commission Delegated Regulation (EU) No 134/2014. (See end of Document for details)

Figure

Grading curve of the aggregate in the asphaltic mix, with tolerances

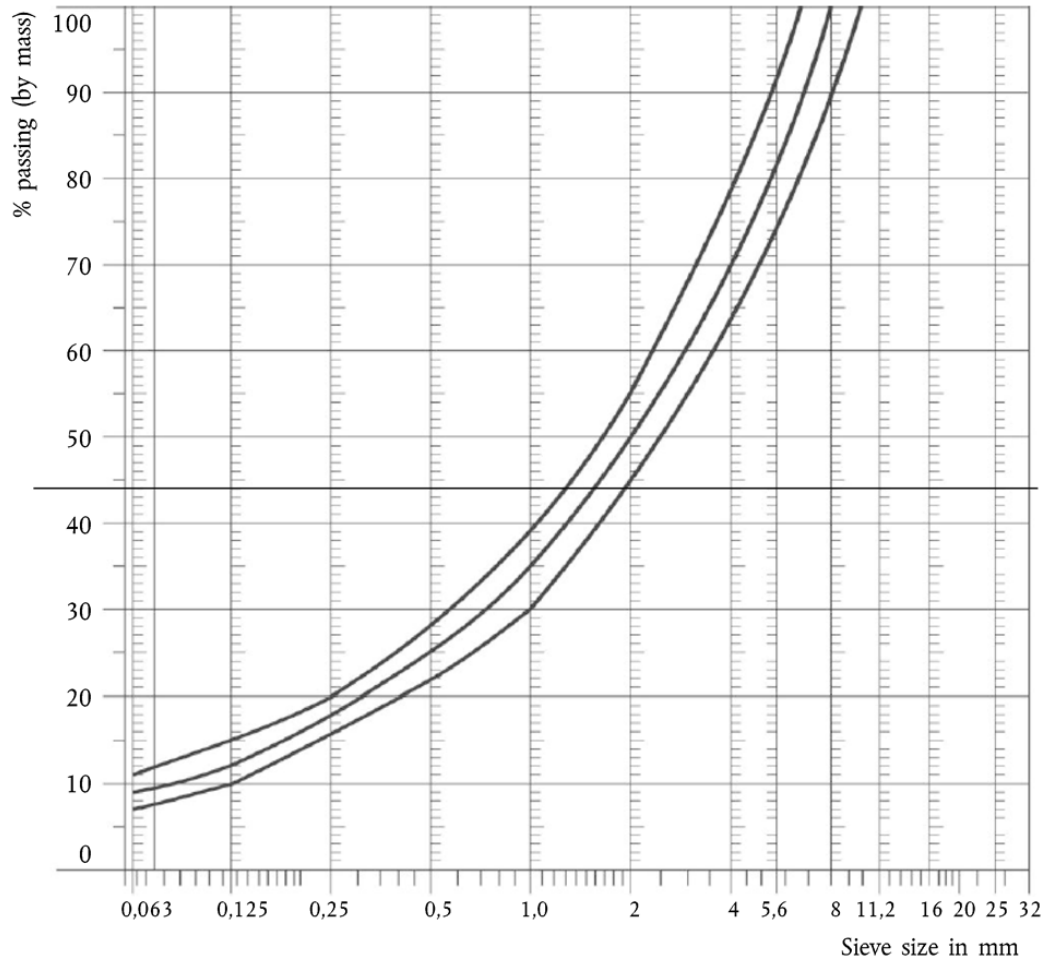

Ap1.1-1

5. The coefficient k is given by the following formula for each vehicle speed measured:

Equation Ap1.1-1:

$$k = \frac{v_d}{v_k}$$

Appendix 2

Requirements concerning the methods for measuring the maximum torque and maximum net power of a propulsion containing a combustion engine or a hybrid propulsion type

1. General requirements

- 1.1. Appendix 2.1. shall apply for the purpose of determining the maximum torque and maximum net power of (spark-ignition) engines for vehicle categories L1e, L2e and L6e.
- 1.2. Appendix 2.2. shall apply for the purpose of determining the maximum torque and maximum net power of (spark-ignition) engines for vehicle categories L3e, L4e, L5e and L7e.
- 1.3. Appendix 2.3. shall apply for the purpose of determining the maximum torque and maximum net power of L-category vehicles equipped with a compression-ignition engine.
- 1.4. Appendix 2.4. shall apply for the purpose of determining the maximum total torque and maximum total power of L-category vehicles equipped with a hybrid propulsion.
- 1.5. The torque measuring system shall be calibrated to take friction losses into account. The accuracy in the lower half of the measuring range of the dynamometer bench may be ± 2 % of measured torque.
- 1.6. The tests may be carried out in air-conditioned test chambers where the atmospheric conditions can be controlled.
- 1.7. In the case of non-conventional propulsion types and systems, and hybrid applications, particulars equivalent to those referred to in this Regulation shall be supplied by the manufacturer.

2. Torque verification requirement for L7e-B heavy all-terrain quads

In order to prove that a L7e-B all-terrain quad is designed for and capable of driving in off-road conditions and can therefore develop sufficient torque, the representative test vehicle shall be capable of climbing a gradient ≥ 25 % calculated for a solo vehicle. Before start of the verification test, the vehicle shall be parked on the slope (vehicle speed = 0 km/h).

Status: Point in time view as at 16/12/2013.

Changes to legislation: There are currently no known outstanding effects for the Commission Delegated Regulation (EU) No 134/2014. (See end of Document for details)

Appendix 2.1

Determination of the maximum torque and maximum net power of spark-ignition engines for vehicle categories L1e, L2e and L6e

1. **Accuracy of maximum torque and maximum net power measurements under full load**
 - 1.1. Torque: $\pm 2\%$ of torque measured.
 - 1.2. Rotational speed: the measurement shall be accurate to $\pm 1\%$ of the full-scale reading.
 - 1.3. Fuel consumption $\pm 2\%$ for all the devices used.
 - 1.4. Temperature of engine induction air: ± 2 K.
 - 1.5. Barometric pressure: ± 70 Pa.
 - 1.6. Pressure in the exhaust and under pressure of the intake air: ± 25 Pa.
2. **Test for the measurements of maximum torque and maximum net engine power**
 - 2.1. Accessories
 - 2.1.1. Accessories to be fitted

During the test, the accessories needed for operation of the engine in the application in question (as set out in Table Ap2.1-1) shall be located on the test bench as far as possible in the position they would occupy for that application.

2.1.2. *TABLE AP2.1-1*

Accessories to be fitted during the propulsion unit performance test in order to determine torque and net engine power

No	Accessories	Fitted for the torque and net power test
1	Air intake system — Induction manifold — Air filter — Induction silencer — Crankcase emission-control system — Electrical control device, where fitted	If series-mounted: yes
2	Exhaust system — Manifold — Pipe work ^a — Silencer — Exhaust pipe	If series-mounted: yes

Status: Point in time view as at 16/12/2013.

Changes to legislation: There are currently no known outstanding effects for the Commission Delegated Regulation (EU) No 134/2014. (See end of Document for details)

	— Electrical control device, where fitted	
3	Carburettor	If series-mounted: yes
4	Fuel injection system — Upstream filter — Filter — Fuel supply pump and high pressure pump if applicable — Compressed air pump in the case of DI air assist — Pipe work — Injector — Air inlet flap ^b , where fitted — Fuel pressure / flow regulator, where fitted	If series-mounted: yes
5	Maximum rotational speed-or power governors	If series-mounted: yes
6	Liquid-cooling equipment — Radiator — Fan ^c — Water Pump — Thermostat ^d	If series-mounted: yes ^e
7	Air cooling — Cowl — Blower — Cooling temperature-regulating device(s) — Auxiliary bench blower	If series-mounted: yes
8	Electrical equipment	If series-mounted: yes ^f
9	Pollution-control devices ^g	If series-mounted: yes
9	Lubrication system — Oil feeder	If series-mounted: yes

a If it is difficult to use the standard exhaust system, an exhaust system causing an equivalent pressure drop may be fitted for the test with the agreement of the manufacturer. In the test laboratory when the engine is in operation, the exhaust gas extraction system shall not cause in the extraction flue at the point where it is connected to the vehicle's exhaust system a pressure differing from atmospheric pressure by ± 740 Pa (7,40 mbar), unless, before the test, the manufacturer accepts a higher back pressure.

b The air inlet flap shall be that which controls the pneumatic inject pump regulator.

Status: Point in time view as at 16/12/2013.

Changes to legislation: There are currently no known outstanding effects for the Commission Delegated Regulation (EU) No 134/2014. (See end of Document for details)

- | | |
|----------|---|
| c | Where a fan or blower may be disengaged, the net engine power shall first of all be stated with the fan (or blower) disengaged, followed by the net engine power with the fan (or blower) engaged. Where a fixed electrically or mechanically-operated fan cannot be fitted on the test bench, the power absorbed by that fan shall be determined at the same rotational speeds as those used when the engine power is measured. That power is deducted from the corrected power in order to obtain the net power. |
| d | The thermostat may be locked in the fully open position. |
| e | The radiator, fan, fan nozzle, water pump and thermostat shall, on the test bench, occupy as far as possible the same position relative to each other as if they were on the vehicle. If the radiator, fan, fan nozzle, water pump or thermostat have a position on the test bench which is different from that on the vehicle, this shall be described and noted in the test report. The liquid coolant shall be circulated solely by the water pump for the engine. It may be cooled either by the engine radiator or by an outside circuit, provided that the pressure drops within that circuit remain substantially the same as those in the engine cooling system. If fitted, the engine blind shall be open. |
| f | Minimum generator output: the generator supplies the current that is strictly needed to supply the accessories that are essential to the operation of the engine. The battery shall not receive any charge during the test. |
| g | Anti-pollution provisions may include, for example, exhaust-gas recirculation (EGR) system, catalytic converter, thermal reactor, secondary air-supply system and fuel-evaporation protecting system. |

2.1.3. Accessories not to be fitted

Certain vehicle accessories which are needed only for use of the vehicle itself, but which are likely to be mounted on the engine, shall be removed for the tests.

The power absorbed by fixed equipment under no load may be determined and added to the power measured.

2.1.4. The radiator, fan, fan nozzle, water pump and thermostat shall, on the test bench, occupy as far as possible the same position relative to each other as if they were on the vehicle. If the radiator, fan, fan nozzle, water pump or thermostat have a position on the test bench which is different from that on the vehicle, the position on the test bench shall be described and noted in the test report.

2.2. Setting conditions

The conditions applying to settings during the tests to determine maximum torque and maximum net power are set out in Table Ap2.1-2.

TABLE AP2.1-2

Setting conditions

1	Setting of carburettor(s)	Setting carried out in accordance with the manufacturer's specifications for series production applied, without any other change, to the use under consideration
2	Setting of fuel injection pump flow-rate	
3	Ignition or injection setting (advance curve)	
4	(Electronic) Throttle Control	
5	Any other rotational speed governor setting	
6	(Noise and tailpipe) emission abatement system settings and devices	

Status: Point in time view as at 16/12/2013.

Changes to legislation: There are currently no known outstanding effects for the Commission Delegated Regulation (EU) No 134/2014. (See end of Document for details)

2.3. Test conditions

- 2.3.1. The tests to determine maximum torque and maximum net power shall be carried out at full throttle, with the engine equipped as specified in Table Ap2.1-1.
- 2.3.2. The measurements shall be carried out under normal, stable operating conditions and the air supply to the engine shall be adequate. The engine shall have been run in under the conditions recommended by the manufacturer. The combustion chambers may contain deposits, but in limited quantities.
- 2.3.3. The test conditions selected, such as the temperature of the induction air, shall resemble the reference conditions (see point 3.2.) as closely as possible in order to reduce the correction factor.
- 2.3.4. The temperature of the engine induction air (ambient air) shall be measured at the most 0,15 m upstream of the air filter inlet or, if there is no filter, 0,15 m from the inlet air trumpet. The thermometer or thermocouple shall be protected against heat radiation and be placed directly in the airstream. It shall also be protected against vaporised fuel. An adequate number of positions shall be used in order to yield a representative average inlet temperature.
- 2.3.5. No measurement shall be taken until the torque, rate of rotation and temperatures have remained substantially constant for at least 30 seconds.
- 2.3.6. Once a rate of rotation has been selected for the measurements, its value shall not vary by more than $\pm 2\%$.
- 2.3.7. Observed brake load and inlet-air temperature data shall be taken simultaneously and shall be the average of two stabilised consecutive values. In the case of the brake load, these values shall not vary by more than 2% .
- 2.3.8. Where an automatically triggered device is used to measure rotational speed and consumption, the measurement shall last for at least ten seconds; if the measuring device is manually controlled, that period shall be at least 20 seconds.
- 2.3.9. The temperature of the liquid coolant recorded at the engine outlet shall be maintained at $\pm 5\text{ K}$ of the upper thermostat setting temperature specified by the manufacturer. If the manufacturer does not indicate any values, the temperature shall be $353,2\text{ K} \pm 5\text{ K}$.

In the case of air-cooled engines, the temperature at a point specified by the manufacturer shall be maintained at $+ 0/- 20\text{ K}$ of the maximum temperature intended by the manufacturer under the reference conditions.

- 2.3.10. The fuel temperature shall be measured at the carburettor or injection system inlet and kept within the limits laid down by the manufacturer.
- 2.3.11. The temperature of the lubricating oil measured in the oil sump or at the outlet from the oil cooler, if fitted, shall be maintained within the limits established by the engine manufacturer.
- 2.3.12. The outlet temperature of the exhaust gases shall be measured at right angles to the exhaust flange(s) or manifold(s) or orifices.
- 2.3.13. Test fuel

The test fuel to be used shall be the reference fuel referred to in Appendix 2 of Annex II.

Status: Point in time view as at 16/12/2013.

Changes to legislation: There are currently no known outstanding effects for the Commission Delegated Regulation (EU) No 134/2014. (See end of Document for details)

2.4. Test procedure

Measurements shall be taken at a sufficient number of engine speeds to define correctly the complete power curve between the lowest and the highest governed engine speeds recommended by the manufacturer. This range of speeds shall include the speeds of revolution at which the engine produces its maximum torque and at which it produces its maximum power. For each speed, the average of at least two stabilised measurements is to be determined.

2.5. The data to be recorded shall be those set out in the template of the test report referred to in Article 32(1) of Regulation (EU) No 168/2013

3. Power and torque correction factors

3.1. Definition of factors α_1 and α_2

3.1.1. α_1 and α_2 shall be factors by which the torque and power measured are to be multiplied in order to determine the torque and power of an engine, taking account of the efficiency of the transmission (factor α_2) used during the tests and in order to bring them within the reference atmospheric conditions specified in 3.2.1 (factor α_1). The power correction formula is as follows:

Equation Ap2.1-1:

$$P_0 = \alpha_1 \times \alpha_2 \times P$$

where:

P_0 = the corrected power (i.e. the power under the reference conditions at the end of the crankshaft);
 α_1 = the correction factor for reference atmospheric conditions;
 α_2 = the correction factor for the efficiency of the transmission;
 P = the power measured (power observed).

3.2. Reference atmospheric conditions

3.2.1. Temperature: 298,2 K (25 °C)

3.2.2. Dry reference pressure (p_{so}): 99 kPa (990 mbar)

Note: the dry reference pressure is based on a total pressure of 100 kPa and a water vapour pressure of 1 kPa.

3.2.3. Atmospheric test conditions

3.2.3.1. During the test, the atmospheric conditions shall lie within the following range:

$$283,2 \text{ K} < T < 318,2 \text{ K}$$

where T is the test temperature (K).

3.3. Determination of the correction factor α_1 ⁽¹¹⁾

Equation Ap2.1-2:

$$\alpha_1 = \left(\frac{99}{p_s}\right)^{1,2} \times \left(\frac{T}{298}\right)^{0,6}$$

where:

T = the absolute temperature of the ingested air

Status: Point in time view as at 16/12/2013.

Changes to legislation: There are currently no known outstanding effects for the Commission Delegated Regulation (EU) No 134/2014. (See end of Document for details)

p_s = the dry atmospheric pressure in kilopascals (kPa), i.e. the total barometric pressure minus the water vapour pressure.

3.3.1. Equation Ap2.1-2 applies only if:

$$0,93 \leq \alpha_1 \leq 1,07$$

If the limit values are exceeded, the corrected value obtained and the test conditions (temperature and pressure) shall be stated exactly in the test report.

3.4. Determination of the correction factor for mechanical efficiency of the transmission α_2

Where:

- the measuring point is the output side of the crankshaft, this factor is equal to 1;
- the measuring point is not the output side of the crankshaft, this factor is calculated using the formula:

Equation Ap2.1-2:

$$\alpha_2 = \frac{1}{\eta_t}$$

where η_t is the efficiency of the transmission located between the crankshaft and the measuring point.

This transmission efficiency η_t is determined from the product (multiplication) of efficiency η_j of each of the components of the transmission:

Equation Ap2.1-3:

$$\eta_t = \eta_1 \times \eta_2 \times \dots \times \eta_j$$

3.4.1. *TABLE AP2.1-3*

Efficiency η_j of each of the components of the transmission

Type		Efficiency
Gear wheel	Spur gear	0,98
	Helical gear	0,97
	Bevel gear	0,96
Chain	Roller	0,95
	Silent	0,98
Belt	Cogged	0,95
	Vee	0,94
Hydraulic coupling or convertor	Hydraulic coupling ^{ab}	0,92
	Hydraulic convertor ^{ab}	0,92

a The test may be carried out in temperature-controlled test chambers where the atmospheric conditions can be controlled.

b If not locked up.

4. Maximum torque and maximum net power measurement tolerances

Status: Point in time view as at 16/12/2013.

Changes to legislation: There are currently no known outstanding effects for the Commission Delegated Regulation (EU) No 134/2014. (See end of Document for details)

The maximum torque and the maximum net power of the engine as determined by the technical service to the satisfaction of the approval authority shall have a maximum acceptable tolerance of:

TABLE AP2.1-4

Acceptable measurement tolerances

Measured power	Acceptable tolerance maximum torque and maximum power
< 1 kW	≤ 10 %
1 kW ≤ measured power ≤ 6 kW	≤ 5 %

Engine speed tolerance when performing maximum torque and net power measurements: ≤ 3 %

Status: Point in time view as at 16/12/2013.

Changes to legislation: There are currently no known outstanding effects for the Commission Delegated Regulation (EU) No 134/2014. (See end of Document for details)

Appendix 2.2

Determination of the maximum torque and maximum net power of spark-ignition engines for vehicle categories L3e, L4e, L5e and L7e

1. **Accuracy of the measurements of maximum net power and maximum torque at full load**
 - 1.1. Torque: $\pm 1\%$ of the torque measured⁽¹²⁾.
 - 1.2. Rotational speed: the measurement shall be accurate to $\pm 1\%$ of the full-scale reading.
 - 1.3. Fuel consumption: $\pm 1\%$ overall for the apparatus used.
 - 1.4. Engine inlet air temperature: $\pm 1\text{ K}$.
 - 1.5. Barometric pressure $\pm 70\text{ Pa}$
 - 1.6. Exhaust pressure and drop in intake air: $\pm 25\text{ Pa}$
2. **Tests to measure the maximum torque and maximum net engine power**
 - 2.1. Accessories
 - 2.1.1. Accessories to be fitted

During the test, it shall be possible to locate the accessories needed for operation of the engine in the application in question (as referred to in Table Ap2.2-1 on the test bench as far as possible in the positions that they would occupy for that application.

2.1.2. *TABLE AP2.2-1*

Accessories to be fitted during the propulsion unit performance test in order to determine torque and net engine power

No	Accessories	Fitted for the torque and net power test
1	Air intake system — Induction manifold — Air filter — Induction silencer — Crankcase emission-control system — Electrical control device, where fitted	If series-mounted: yes
2	Induction manifold heater	If series-mounted: yes (if possible, it shall be set

a Charge air-cooled engines shall be tested with charge air cooling, whether liquid or air-cooled, but if the manufacturer prefers, a test bench may replace the air-cooled cooler. In either case, the measurement of power at each speed shall be made with the same pressure drop of the engine air across the charge air cooler on the test-bench system as those specified by the manufacturer for the system on the complete vehicle.

Status: Point in time view as at 16/12/2013.

Changes to legislation: There are currently no known outstanding effects for the Commission Delegated Regulation (EU) No 134/2014. (See end of Document for details)

		in the most favourable position)
3	Exhaust system — Exhaust manifold — Exhaust clean-up system (secondary air system) (where fitted) — Pipe work ¹ — Silencer ¹ — Exhaust pipe ¹ — Electrical control device, where fitted	If series-mounted: yes
4	Carburettor	If series-mounted: yes
5	Fuel injection system — Upstream filter — Filter — Fuel supply pump and high pressure pump if applicable — High-pressure lines — Injector — Air inlet flap ² , where fitted — Fuel pressure / flow regulator, where fitted	If series-mounted: yes
6	Maximum rotational speed-or power governors	If series-mounted: yes
7	Liquid-cooling equipment — Engine bonnet — Radiator — Fan ³ — Fan cowl — Water pump — Thermostat ⁴	If series-mounted: yes ⁵
8	Air cooling — Cowl — Blower ³	If series-mounted: yes

a Charge air-cooled engines shall be tested with charge air cooling, whether liquid or air-cooled, but if the manufacturer prefers, a test bench may replace the air-cooled cooler. In either case, the measurement of power at each speed shall be made with the same pressure drop of the engine air across the charge air cooler on the test-bench system as those specified by the manufacturer for the system on the complete vehicle.

Status: Point in time view as at 16/12/2013.

Changes to legislation: There are currently no known outstanding effects for the Commission Delegated Regulation (EU) No 134/2014. (See end of Document for details)

	— Cooling temperature-regulating device(s) — Auxiliary bench blower	
9	Electrical equipment	If series-mounted: yes ⁶
10	Super-charger or turbocharger, where fitted — Compressor driven directly by the engine or by the exhaust gases — Charge air cooler ^a — Coolant pump or fan (engine driven) — Coolant flow control device, where fitted.	If series-mounted: yes
11	Pollution-control devices ⁷	If series-mounted: yes
12	Lubrication system — Oil feeder — Oil cooler, where fitted.	If series-mounted: yes

a Charge air-cooled engines shall be tested with charge air cooling, whether liquid or air-cooled, but if the manufacturer prefers, a test bench may replace the air-cooled cooler. In either case, the measurement of power at each speed shall be made with the same pressure drop of the engine air across the charge air cooler on the test-bench system as those specified by the manufacturer for the system on the complete vehicle.

2.1.3. Accessories to be removed

Certain accessories which are necessary only for the operation of the vehicle itself, and which may be mounted on the engine, shall be removed for the test.

Where accessories cannot be removed, the power absorbed by them under no load may be determined and added to the engine power measured.

2.2. Setting conditions

The conditions applying to settings during the tests to determine maximum torque and maximum net power are set out in Table Ap2.1-2.

TABLE AP2.2-2

Setting conditions

1	Setting of carburettor(s)	Setting carried out in accordance with the manufacturer's specifications for series production applied,
2	Setting of injection pump flow-rate	

Status: Point in time view as at 16/12/2013.

Changes to legislation: There are currently no known outstanding effects for the Commission Delegated Regulation (EU) No 134/2014. (See end of Document for details)

3	Ignition or injection setting (advance curve)	without any other change, to the use under consideration
4	(Electronic) Throttle control	
5	Any other rotational speed governor setting	
6	(Noise and tailpipe) emission abatement system settings and devices	

2.3. Test conditions

2.3.1. The maximum-torque and net-power tests shall be conducted at full throttle, the engine being equipped as specified in Table Ap2.2-1.

2.3.2. The measurements shall be carried out under normal, stabilised operating conditions with an adequate fresh-air supply to the engine. The engine shall have been run in accordance with the manufacturer's recommendations. Combustion chambers may contain deposits, but in limited quantities.

2.3.3. The test conditions selected, such as air inlet temperature, shall resemble reference conditions (see point 3.2.) as closely as possible in order to minimise the magnitude of the correction factor.

2.3.4. Where the cooling system on the test bench meets the minimum conditions for proper installation but nevertheless does not enable adequate cooling conditions to be reproduced and thus the measurements to be carried out in normal, stable operating conditions, the method described in Appendix 1 may be used.

2.3.5. The minimum conditions which shall be fulfilled by the test installation and the scope for conducting the tests in accordance with Appendix 1 are laid down as follows:

2.3.5.1. v_1 is the maximum speed of the vehicle;

v_2 is the maximum velocity of the cooling air flow at the fan delivery side;

\emptyset is the cross-section of the cooling air flow.

2.3.5.2. If $v_2 \geq v_1$ and $\emptyset \geq 0,25 \text{ m}^2$, the minimum conditions are fulfilled. If it is not possible to stabilise the operating conditions, the method described in Appendix 1 shall apply.

2.3.5.3. If $v_2 < v_1$ or $\emptyset < 0,25 \text{ m}^2$:

2.3.5.3.1. if it is possible to stabilise the operating conditions, the method described in point 3.3. shall be applied;

2.3.5.3.2. if it is not possible to stabilise the operating conditions:

2.3.5.3.2. If $v_2 \geq 120 \text{ km/h}$ and $\emptyset \geq 0,25 \text{ m}^2$, the installation fulfils the minimum conditions and the method described in Appendix 1 may be applied;

Status: Point in time view as at 16/12/2013.

Changes to legislation: There are currently no known outstanding effects for the Commission Delegated Regulation (EU) No 134/2014. (See end of Document for details)

2.3.5.3.2.2. If $v_2 \geq 120$ km/h or $\text{Ø} < 0,25$ m², the installation does not fulfil the minimum conditions and the test equipment cooling system shall be improved.

2.3.5.3.2.3. However, in this case, the test may be carried out by means of the method described in Appendix 1, subject to approval by the manufacturer and the approval authority.

2.3.6. The temperature of the (ambient) inlet air to the engine shall be measured at no more than 0,15 m upstream from the point of entry into the air cleaner or, if no air cleaner is used, within 0,15 m of the air-inlet trumpet. The thermometer or thermocouple shall be shielded from radiant heat and be placed directly in the airstream. It shall also be shielded from fuel spray-back.

A sufficient number of locations shall be used to give a representative average inlet temperature.

2.3.7. No data shall be taken until torque, speed and temperature have remained substantially constant for at least 30 seconds.

2.3.8. The engine speed during a run or reading shall not deviate from the selected speed by more than ± 1 % or ± 10 min⁻¹, whichever is greater.

2.3.9. Observed brake load and inlet-air temperature data shall be taken simultaneously and shall be the average of two stabilised consecutive values. In the case of the brake load, these values shall not vary by more than 2 %.

2.3.10. The temperature of the coolant at the outlet from the engine shall be kept within ± 5 K of the upper thermostatically controlled temperature specified by the manufacturer. If no temperature is specified by the manufacturer, the temperature shall be $353,2 \pm 5$ K.

For air-cooled engines, the temperature at a point indicated by the manufacturer shall be kept between $+ 0/ - 20$ K of the maximum temperature specified by the manufacturer under the reference conditions.

2.3.11. The fuel temperature shall be measured at the inlet of the carburettor or injection system and be maintained within the limits set by the manufacturer.

2.3.12. The temperature of the lubricating oil measured in the oil sump or at the outlet from the oil cooler, if fitted, shall be maintained within the limits stipulated by the engine manufacturer.

2.3.13. The outlet temperature of the exhaust gases shall be measured at right angles to the exhaust flange(s), manifold(s) or orifices.

2.3.14. Where an automatically triggered device is used to measure engine speed and consumption, the measurement shall last at least ten seconds; if the measuring device is manually controlled, it shall measure for at least 20 seconds.

2.3.15. Test fuel

The test fuel to be used shall be the reference fuel referred to in Appendix 2 of Annex II.

2.3.16. If it is not possible to use the standard exhaust silencer, a device shall be used for the test that is compatible with the engine's normal operating conditions, and specified by the manufacturer.

Status: Point in time view as at 16/12/2013.

Changes to legislation: There are currently no known outstanding effects for the Commission Delegated Regulation (EU) No 134/2014. (See end of Document for details)

During the laboratory tests in particular, when the engine is running, the exhaust gas extractor shall not, at the point where the exhaust system is connected to the test bench, give rise in the exhaust-gas extraction duct to a pressure differing from the atmospheric pressure by more than ± 740 Pa (7,4 mbar) unless the manufacturer has deliberately specified the back pressure existing before the test; in this case, the lower of the two pressures shall be used.

2.4. Test procedure

Measurements shall be taken at a sufficient number of engine speeds to define correctly the complete power curve between the lowest and the highest engine speeds recommended by the manufacturer. This range of speeds shall include the speeds of revolution at which the engine produces its maximum torque and at which it produces its maximum power. For each speed, the average of at least two stabilised measurements is to be determined.

2.5. Data to be recorded

The data to be recorded shall be those set out in the template of the test report referred to in Article 32(1) of Regulation (EU) No 168/2013.

3. Power and torque correction factors

3.1. Definition of factors α_1 and α_2

3.1.1. α_1 and α_2 shall be factors by which the torque and power measured are to be multiplied in order to determine the torque and power of an engine, taking account of the efficiency of the transmission (factor α_2) used during the tests and in order to bring them within the reference atmospheric conditions specified in point 3.2.1 (factor α_1). The power correction formula is as follows:

Equation Ap2.2-1:

$$P_0 = \alpha_1 \times \alpha_2 \times P$$

where:

P_0	= the corrected power (i.e. the power under the reference conditions at the end of the crankshaft);
α_1	= the correction factor for reference atmospheric conditions;
α_2	= the correction factor for the efficiency of the transmission;
P	= the power measured (power observed).

3.2. Reference atmospheric conditions

3.2.1. Temperature: 298,2 K (25 °C)

3.2.2. Dry reference pressure (p_{so}): 99 kPa (990 mbar)

Note: the dry reference pressure is based on a total pressure of 100 kPa and a water vapour pressure of 1 kPa.

3.2.3. Atmospheric test conditions

3.2.3.1. During the test, the atmospheric conditions shall lie within the following range:

$$283,2 \text{ K} < T < 318,2 \text{ K}$$

where T is test temperature (K).

3.3. Determination of the correction factor α_1 ⁸

Status: Point in time view as at 16/12/2013.

Changes to legislation: There are currently no known outstanding effects for the Commission Delegated Regulation (EU) No 134/2014. (See end of Document for details)

Equation Ap2.2-2:

$$\alpha_1 = \left(\frac{99}{P_s}\right)^{3,2} \times \left(\frac{T}{298}\right)^{0,6}$$

where:

- T = the absolute temperature of the ingested air
- P_s = the dry atmospheric pressure in kilopascals (kPa), i.e. the total barometric pressure minus the water vapour pressure.

3.3.1. Equation Ap2.2-2 applies only if:

$$0,93 \leq \alpha_1 \leq 1,07$$

If the limit values are exceeded, the corrected value obtained shall be stated and the test conditions (temperature and pressure) stated exactly in the test report.

3.4. Determination of the correction factor for mechanical efficiency of the transmission α_2

Where:

- the measuring point is the output side of the crankshaft, this factor is equal to 1;
- the measuring point is not the output side of the crankshaft, this factor is calculated using the formula:

Equation Ap2.2-2:

$$\alpha_2 = \frac{1}{n_t}$$

where n_t is the efficiency of the transmission located between the crankshaft and the measuring point.

This transmission efficiency n_t is determined from the product (multiplication) of efficiency n_j of each of the components of the transmission:

Equation Ap2.2-3:

$$n_t = n_1 \times n_2 \times \dots \times n_j$$

3.4.1.

TABLE AP2.1-3

Efficiency n_j of each of the components of the transmission

Type		Efficiency
Gear wheel	Spur gear	0,98
	Helical gear	0,97
	Bevel gear	0,96
Chain	Roller	0,95
	Silent	0,98
Belt	Cogged	0,95
	Vee	0,94
Hydraulic coupling or convertor	Hydraulic coupling ⁹	0,92
	Hydraulic convertor ⁹	0,92

4. Maximum torque and maximum net power measurement tolerances

Status: Point in time view as at 16/12/2013.

Changes to legislation: There are currently no known outstanding effects for the Commission Delegated Regulation (EU) No 134/2014. (See end of Document for details)

The maximum torque and the maximum net power of the engine as determined by the technical service to the satisfaction of the approval authority shall have a maximum acceptable tolerance of:

TABLE AP2.2-4

Acceptable measurement tolerances

Measured power	Acceptable tolerance maximum torque and maximum power
≤ 11 kW	≤ 5 %
> 11 kW	≤ 2 %

Engine speed tolerance when performing maximum torque and net power measurements:
 $\leq 1,5$ %

Appendix 2.2.1

Measurement of maximum torque and maximum net engine power by means of the engine-temperature method

1. Test conditions

- 1.1. The tests to determine maximum torque and maximum net power shall be carried out at full throttle, the engine being equipped as specified in Table Ap2.2-1
- 1.2. The measurements shall be taken under normal operating conditions and the supply of induction air to the engine shall be adequate. Engines shall have been run in under the conditions recommended by their manufacturer. The combustion chambers of spark-ignition engines may contain deposits, but in limited quantities.

The test conditions selected, such as the temperature of the induction air, shall resemble the reference conditions (see point 3.2.) as closely as possible in order to reduce the magnitude of the correction factor.

- 1.3. The temperature of the air ingested into the engine shall be measured at a maximum distance of 0,15 m from the air filter inlet or, if there is no filter, 0,15 m from the air inlet trumpet. The thermometer or thermocouple shall be protected against radiant heat and placed directly in the air stream. It shall also be shielded from fuel spray-back. A sufficient number of locations shall be used to give a representative average inlet temperature.
- 1.4. The engine speed during a measurement run shall not deviate by more than $\pm 1 \%$ from the selected speed while readings are taken.
- 1.5. The brake load readings for the test engine shall be taken from the dynamometer when the temperature of the engine monitor has reached the set value, the speed of the engine being held virtually constant.
- 1.6. Brake load, fuel consumption and inlet air-temperature readings shall be taken simultaneously; the reading adopted for measurement purposes is the average of two stabilised values. For brake load and fuel consumption, these values shall differ by less than 2 %.
- 1.7. The fuel consumption readings shall begin when it is certain that the engine has reached a specific speed.

Where an automatically triggered device is used to measure rotational speed and consumption, the measurement shall last at least ten seconds; if the measuring device is manually controlled, it shall last at least 20 seconds.

- 1.8. Where the engine is liquid-cooled, the temperature of the coolant at the outlet from the engine shall be kept within $\pm 5 \text{ K}$ of the upper thermostatically controlled temperature specified by the manufacturer. If no temperature is specified by the manufacturer, the temperature recorded shall be $353,2 \pm 5 \text{ K}$.

Where the engine is air-cooled, the temperature recorded at the spark-plug washer shall be the temperature specified by the manufacturer $\pm 10 \text{ K}$. If the manufacturer has not specified any temperature, that recorded shall be $483 \pm 10 \text{ K}$.

- 1.9. The temperature of the spark-plug washers on air-cooled engines shall be measured with a thermometer incorporating a thermocouple and a seal ring.

Status: Point in time view as at 16/12/2013.

Changes to legislation: There are currently no known outstanding effects for the Commission Delegated Regulation (EU) No 134/2014. (See end of Document for details)

- 1.10. The fuel temperature at the inlet of the injection pump or carburettor shall be maintained within the limits set by the manufacturer.
- 1.11. The temperature of the lubricating oil, measured in the oil sump or at the outlet from the oil cooler, if fitted, shall be within the limits set by the manufacturer.
- 1.12. The exhaust gas temperature shall be measured at a point at right angles to the exhaust orifice flange(s) or manifold(s).
- 1.13. The fuel used shall be that referred to in appendix 2 of Annex II.
- 1.14. If it is not possible to use the standard exhaust silencer for the test, a device shall be used that is compatible with the normal speed of the engine as specified by its manufacturer. In particular, when the engine is operating in the test laboratory, the exhaust gas extraction system shall not cause a pressure differing from atmospheric pressure by ± 740 Pa (7,40 mbar) in the extraction flue at the point of connection with the exhaust system of the vehicle, unless the manufacturer has deliberately specified the back pressure existing before the test, in which case the lower of the two pressures shall be used.

Status: Point in time view as at 16/12/2013.

Changes to legislation: There are currently no known outstanding effects for the Commission Delegated Regulation (EU) No 134/2014. (See end of Document for details)

Appendix 2.3

Determination of the maximum torque and maximum net power of L-category vehicles equipped with a compression ignition engine

1. Accuracy of the measurement of full load torque and power

1.1. Torque: $\pm 1\%$ of measured torque

1.2. Engine speed

The measurement shall be accurate to within $\pm 1\%$ of the full-scale reading. Engine speed shall be measured preferably with an automatically synchronised revolution counter and chronometer (or counter-timer).

1.3. Fuel consumption: $\pm 1\%$ of measured consumption.

1.4. Fuel temperature: ± 2 K.

1.5. Engine inlet air temperature: ± 2 K.

1.6. Barometric pressure: ± 100 Pa.

1.7. Pressure in inlet manifold⁽¹³⁾: ± 50 Pa.

1.8. Pressure in vehicle exhaust pipe: 200 Pa.

2. Tests to measure the maximum torque and maximum net engine power

2.1. Accessories

2.1.1. Accessories to be fitted

During the test it is possible to locate the accessories needed for operation of the engine in the application in question (as referred to in Table Ap2.3-1 on the test bench as far as possible in the positions that they would occupy for that application).

2.1.2. *TABLE AP2.3-1*

Accessories to be fitted during the propulsion unit performance test in order to determine torque and net engine power

No	Accessories	Fitted for the torque and net power test
1	Air intake system — Induction manifold — Air filter ^a — Induction silencer — Crankcase emission-control system — Electrical control device, where fitted	If series-mounted: yes

Status: Point in time view as at 16/12/2013.

Changes to legislation: There are currently no known outstanding effects for the Commission Delegated Regulation (EU) No 134/2014. (See end of Document for details)

2	Induction manifold heater	If series-mounted: yes (if possible, it shall be set in the most favourable position)
3	Exhaust system — Exhaust purifier — Exhaust manifold — Pipe work ^b — Silencer ^b — Exhaust pipe ^b — Exhaust brake ^c — Electrical control device, where fitted	If series-mounted: yes
5	Fuel injection system — Upstream filter — Filter — Fuel supply pump ^d and high pressure pump if applicable — High-pressure lines — Injector — Air intake valve ^e , where fitted — Fuel pressure / flow regulator, where fitted	If series-mounted: yes
6	Maximum rotational speed-or power governors ^a	If series-mounted: yes
7	Liquid-cooling equipment — Engine bonnet — Bonnet air outlet — Radiator — Fan ^c — Fan cowl — Water pump — Thermostat ^d	If series-mounted: yes ^e
8	Air cooling — Cowl — Blower ^{fg} — Cooling temperature-regulating device(s)	If series-mounted: yes

Status: Point in time view as at 16/12/2013.

Changes to legislation: There are currently no known outstanding effects for the Commission Delegated Regulation (EU) No 134/2014. (See end of Document for details)

	— Auxiliary bench blower	
9	Electrical equipment	If series-mounted: yes ^h
10	Super-charger or turbocharger, where fitted — Compressor driven directly by the engine or by the exhaust gases — Charge air cooler ^b — Coolant pump or fan (engine driven) — Coolant flow control device, where fitted.	If series-mounted: yes
11	Pollution-control devices ^g	If series-mounted: yes
12	Lubrication system — Oil feeder — Oil cooler, where fitted.	If series-mounted: yes

- a** The complete air intake system shall be fitted as provided for the intended application:
- where there is a risk of an appreciable effect on the engine power,
 - in the case of two-stroke engines,
 - when the manufacturer requests that this should be done. In other cases, an equivalent system may be used and a check should be made to ascertain that the intake pressure does not differ by more than 100 Pa from the limit specified by the manufacturer for a clean air filter.
- b** The complete exhaust system shall be fitted as provided for the intended application:
- where there is a risk of an appreciable effect on the engine power,
 - in the case of two-stroke engines,
 - when the manufacturer requests that this should be done. In other cases an equivalent system may be installed provided the pressure measured at the exit of the engine exhaust system does not differ by more than 1 000 Pa from that specified by the manufacturer. The exit of the engine exhaust system is defined as a point 150 mm downstream from the termination of the part of the exhaust system mounted on the engine.
- c** If an exhaust brake is incorporated in the engine, the throttle valve shall be held in the fully open position.
- d** The fuel-feed pressure may be adjusted, if necessary, to reproduce the pressures existing in the particular engine application (particularly when a 'fuel-return' system is used).
- e** The air-intake valve is the control valve for the pneumatic governor of the injection pump. The governor or the fuel-injection equipment may contain devices which can affect the amount of injected fuel.
- f** The radiator, fan, fan nozzle, water pump and thermostat shall, on the test bench, occupy as far as possible the same position relative to each other as if they were on the vehicle. If any of them have a position on the test bench which is different from that on the vehicle, this shall be described and noted in the test report. The cooling-liquid circulation shall be operated by the engine water pump only. Cooling of the liquid may be produced either by the engine radiator or by an external circuit, provided that the pressure loss of this circuit and the pressure at the pump inlet remain substantially the same as those of the engine cooling system. The radiator shutter, if incorporated, shall be in the open position. Where the fan, radiator and cowl system cannot conveniently be fitted to the engine, the power absorbed by the fan when separately mounted in its correct position in relation to the radiator and cowl (if used) shall be determined at the speeds corresponding to the engine speeds used for measurement of the engine power either by calculation from standard characteristics or by practical tests. This power, corrected to the standard atmospheric conditions defined in point 4.2, shall be deducted from the corrected power.

Status: Point in time view as at 16/12/2013.

Changes to legislation: There are currently no known outstanding effects for the Commission Delegated Regulation (EU) No 134/2014. (See end of Document for details)

- | | |
|----------|--|
| g | Where a disconnectable or progressive fan or blower is incorporated, the test shall be carried out with the disconnectable fan (or blower) disconnected or with the progressive fan or blower running at maximum slip. |
| h | Minimum power of the generator: the power of the generator shall be no more than that required to operate accessories which are indispensable for the operation of the engine. If the connection of a battery is necessary, a fully-charged battery in good order shall be used. |

2.1.3. Accessories to be removed

Certain vehicle accessories necessary only for the operation of the vehicle and which may be mounted on the engine shall be removed for the test.

The following non-exhaustive list is given as an example:

- air compressor for brakes,
- power-steering compressor,
- suspension compressor,
- air-conditioning system.

Where accessories cannot be removed, the power absorbed by them in the unloaded condition may be determined and added to the measured engine power.

2.1.4. Compression-ignition engine starting accessories

For the accessories used in starting compression-ignition engines, the two following cases shall be considered:

- (a) electrical starting: the generator is fitted and supplies, where necessary, the accessories indispensable to the operation of the engine;
- (b) starting other than electrical: if there are any electrically-operated accessories indispensable to the operation of the engine, the generator is fitted to supply these accessories. Otherwise it is removed.

In either case, the system for producing and accumulating the energy necessary for starting is fitted and operated in the unloaded condition.

2.2. Setting conditions

The conditions applying to settings during the tests to determine maximum torque and maximum net power are set out in Table Ap2.3-2.

TABLE AP2.3-2

Setting conditions

1	Setting of injection pump delivery system	Setting carried out in accordance with the manufacturer's specifications for series production applied, without any other change, to the use under consideration
2	Ignition or injection setting (timing curve)	
3	(Electronic) Throttle control	
4	Any other rotational speed governor setting	
5	(Noise and tailpipe) emission abatement system settings and devices	

Status: Point in time view as at 16/12/2013.

Changes to legislation: There are currently no known outstanding effects for the Commission Delegated Regulation (EU) No 134/2014. (See end of Document for details)

2.3. Test conditions

2.3.1. The maximum-torque and net-power tests shall be conducted at full load fuel-injection pump setting, the engine being equipped as specified in Table Ap2.3-1.

2.3.2. The measurements shall be carried out under normal, stabilised operating conditions with an adequate fresh-air supply to the engine. The engine shall have been run in accordance with the manufacturer's recommendations. Combustion chambers may contain deposits, but in limited quantities.

2.3.3. The test conditions selected, such as air inlet temperature, shall resemble reference conditions (see point 3.2.) as closely as possible in order to minimise the magnitude of the correction factor.

2.3.4. The temperature of the (ambient) inlet air to the engine shall be measured at no more than 0,15 m upstream from the point of entry into the air cleaner or, if no air cleaner is used, within 0,15 m of the air-inlet trumpet. The thermometer or thermocouple shall be shielded from radiant heat and be placed directly in the airstream. It shall also be shielded from fuel spray-back.

A sufficient number of locations shall be used to give a representative average inlet temperature.

2.3.7. No data shall be taken until torque, speed and temperature have remained substantially constant for at least 30 seconds.

2.3.8. The engine speed during a run or reading shall not deviate from the selected speed by more than $\pm 1\%$ or $\pm 10 \text{ min}^{-1}$, whichever is greater.

2.3.9. Observed brake-load and inlet-air temperature data shall be taken simultaneously and shall be the average of two stabilised consecutive values. In the case of the brake load, these values shall not vary more than 2 %.

2.3.10. The temperature of the coolant at the outlet from the engine shall be kept within $\pm 5 \text{ K}$ of the upper thermostatically controlled temperature specified by the manufacturer. If no temperature is specified by the manufacturer, the temperature shall be $353,2 \pm 5 \text{ K}$.

For air-cooled engines, the temperature at a point indicated by the manufacturer shall be kept between $+ 0 / - 20 \text{ K}$ of the maximum temperature specified by the manufacturer under the reference conditions.

2.3.11. The fuel temperature shall be measured at the inlet of the injection system and maintained within the limits set by the manufacturer.

2.3.12. The temperature of the lubricating oil measured in the oil sump or at the outlet from the oil cooler, if fitted, shall be maintained within the limits established by the engine manufacturer.

2.3.13. The outlet temperature of the exhaust gases shall be measured at right angles to the exhaust flange(s), manifold(s) or orifices.

2.3.14. An auxiliary regulating system may be used if necessary to maintain the temperature within the limits specified in points 2.3.10., 2.3.11 and 2.3.12.

2.3.15. Where an automatically triggered device is used to measure engine speed and consumption, the measurement shall last at least ten seconds; if the measuring device is manually controlled, it shall measure for at least 20 seconds.

Status: Point in time view as at 16/12/2013.

Changes to legislation: There are currently no known outstanding effects for the Commission Delegated Regulation (EU) No 134/2014. (See end of Document for details)

2.3.16. Test fuel

The test fuel to be used shall be the reference fuel referred to in Appendix 2 of Annex II.

- 2.3.17. If it is not possible to use the standard exhaust silencer for the test, a device shall be used that is compatible with the engine's normal operating conditions, and specified by the manufacturer.

During the laboratory tests in particular, when the engine is running, the exhaust gas extractor shall not, at the point where the exhaust system is connected to the test bench, give rise in the exhaust-gas extraction duct to a pressure differing from the atmospheric pressure by more than ± 740 Pa (7,4 mbar) unless the manufacturer has deliberately specified the back pressure existing before the test; in this case, the lower of the two pressures shall be used.

2.4. Test procedure

Measurements shall be taken at a sufficient number of engine speeds to define correctly the complete power curve between the lowest and the highest engine speeds recommended by the manufacturer. This range of speeds shall include the speeds of revolution at which the engine produces its maximum torque and at which it produces its maximum power. For each speed, the average of at least two stabilised measurements is to be determined.

2.5. Measurement of smoke index

In the case of compression-ignition engines, the exhaust gases shall be examined during the test for compliance with the requirements for test type II.

2.6. Data to be recorded

The data to be recorded are those set out in the template of the test report referred to in Article 32(1) of Regulation (EU) No 168/2013.

3. Power and torque correction factors

3.1. Definition of factors α_d and α_2

- 3.1.1. α_d and α_2 shall be factors by which the torque and power measured are to be multiplied in order to determine the torque and power of an engine, taking account of the efficiency of the transmission (factor α_2) used during the tests and in order to bring them within the reference atmospheric conditions specified in point 3.2.1 (factor α_d). The power correction formula is as follows:

Equation Ap2.3-1:

$$P_0 = \alpha_d \times \alpha_2 \times P$$

where:

- P_0 = the corrected power (i.e. the power under the reference conditions at the end of the crankshaft);
- α_d = the correction factor for reference atmospheric conditions;
- α_2 = the correction factor for the efficiency of the transmission (see point 3.4 of Appendix 2.2.);
- P = the power measured (power observed).

3.2. Reference atmospheric conditions

- 3.2.1. Temperature: 298,2 K (25 °C)

Status: Point in time view as at 16/12/2013.

Changes to legislation: There are currently no known outstanding effects for the Commission Delegated Regulation (EU) No 134/2014. (See end of Document for details)

3.2.2. Dry reference pressure (p_{so}): 99 kPa (990 mbar)

Note: the dry reference pressure is based on a total pressure of 100 kPa and a water vapour pressure of 1 kPa.

3.2.3. Atmospheric test conditions

3.2.3.1. During the test, the atmospheric conditions shall lie within the following range:

$$283,2 \text{ K} < T < 318,2 \text{ K}$$

$$80 \text{ kPa} \leq p_s \leq 110 \text{ kPa}$$

where:

T = test temperature (K);

p_s = the dry atmospheric pressure in kilopascals (kPa), i.e. the total barometric pressure minus the water vapour pressure.

3.3. Determination of the correction factor α_d ⁽¹⁴⁾

Equation Ap2.3-2:

The power correction factor (α_d) for compression-ignition engines at constant fuel rate is obtained by applying the formula:

$$\alpha_d = (f_a) f_m$$

where:

f_a = the atmospheric factor

f_m = the characteristic parameter for each type of engine and adjustment.

3.3.1. Atmospheric factor f_a

This factor indicates the effects of environmental conditions (pressure, temperature and humidity) on the air drawn in by the engine. The atmospheric factor formula differs according to type of engine.

3.3.1.1. Naturally aspirated and mechanically supercharged engines

Equation Ap2.3-3:

$$f_a = \left(\frac{99}{P_s}\right) \times \left(\frac{T}{288}\right)^{0,7}$$

where:

T = the absolute temperature of the ingested air (K)

p_s = the dry atmospheric pressure in kilopascals (kPa), i.e. the total barometric pressure minus the water vapour pressure.

3.3.1.2. Turbocharger engines or without cooling of inlet air

Equation Ap2.3-4:

$$f_a = \left(\frac{99}{P_s}\right)^{0,7} \times \left(\frac{T}{288}\right)^{1,5}$$

3.3.2. Engine factor f_m

f_m is a function of q_c (fuel flow corrected) as follows:

Equation Ap2.3-5:

Status: Point in time view as at 16/12/2013.

Changes to legislation: There are currently no known outstanding effects for the Commission Delegated Regulation (EU) No 134/2014. (See end of Document for details)

$$f_m = 0.036 \times q_c - 1.14$$

where:

Equation Ap2.3-6:

$$q_c = \frac{q}{r}$$

where:

- q = the fuel flow in milligrams per cycle per litre of total swept volume (mg/(litre · cycle))
- r = the pressure ratio of compressor outlet and compressor inlet (r = 1 for naturally aspirated engines)

3.3.2.1. This formula is valid for a value interval of q_c included between 40 mg/(litre · cycle) and 65 mg/(litre · cycle).

For q_c values lower than 40 mg/(litre · cycle), a constant value of f_m equal to 0.3 ($f_m = 0.3$) will be taken.

For q_c values higher than 65 mg/(litre · cycle), a constant value of f_m equal to 1.2 ($f_m = 1.2$) will be taken (see the figure).

3.3.2.2. Figure Ap2.3-1 Characteristic parameter f_m for each type of engine and adjustment as function of corrected fuel flow

3.3.3. Conditions to be complied with in the laboratory

For a test to be valid, the correction factor α_d shall be such that:

$$0,9 \alpha_d \leq 1.1$$

If these limits are exceeded, the corrected value obtained shall be given and the test conditions (temperature and pressure) stated precisely in the test report.

4. Measuring maximum torque and maximum net power tolerances

The tolerances set out in point 4 of Appendix 2.2 shall apply.

Appendix 2.4

Determination of the maximum torque and maximum power of L-category vehicles equipped with a hybrid propulsion

1. Requirements

1.1. Hybrid propulsion including a positive ignition combustion engine

The maximum total torque and maximum total power of the hybrid propulsion assembly of combustion engine and electric motor shall be measured according to the requirements of Appendix 2.2.

1.2. Hybrid propulsion including a compression ignition combustion engine

The maximum total torque and maximum total power of the hybrid propulsion assembly of combustion engine and electric motor shall be measured according to the requirements of Appendix 2.3.

1.3. Hybrid propulsion including an electric motor

Paragraph 1.1. or 1.2. shall apply and, in addition, the maximum torque and maximum continuous rated power of the electric motor shall be measured according to the requirements of Appendix 3.

1.4. If the hybrid technology used on the vehicle allows multi-mode hybrid running conditions, the same procedure shall be repeated for each mode and the highest measured propulsion unit performance value shall be taken as the final test result of the propulsion unit performance test procedure.

2. Manufacturer's obligation

The vehicle manufacturer shall ensure that the test set-up of the test vehicle equipped with a hybrid propulsion shall result in the maximum attainable total torque and power being measured. Any series-mounted feature resulting in a higher propulsion unit performance in terms of maximum design vehicle speed, maximum total torque or maximum total power shall be regarded as a defeat device.

Status: Point in time view as at 16/12/2013.

Changes to legislation: There are currently no known outstanding effects for the Commission Delegated Regulation (EU) No 134/2014. (See end of Document for details)

Appendix 3

Requirements concerning the methods for measuring the maximum torque and maximum continuous rated power of a pure electric propulsion type

1. Requirements

- 1.1. L-category vehicles equipped with a pure electric propulsion shall meet all the relevant requirements with regard to the measurements of the maximum torque and the maximum thirty minute power of electric drive trains set out in UNECE regulation No 85.
- 1.2. By means of derogation if the manufacturer can prove to the technical service to the satisfaction of the approval authority that the vehicle is physically not capable of achieving the thirty minutes speed the maximum fifteen minute speed may be used instead.

Appendix 4

Requirements concerning the method for measuring the maximum continuous rated power, switch-off distance and maximum assistance factor of an L1e category vehicle designed to pedal referred to in Article 3(94b) of Regulation (EU) No 168/2013

1. **Scope**

- 1.1. Sub-category L1e-A vehicle;
- 1.2. Sub-category L1e-B vehicle equipped with pedal assistance referred to in Article 3(94b) of Regulation (EU) No 168/2013.

2. **Exemption**

L1e vehicles within the scope of this Appendix shall be exempted from the requirements of Appendix 1.

3. **Test procedures and requirements**

- 3.1. Test procedure to measure the maximum design vehicle speed up to which the auxiliary motor provides pedal assist.

The test procedure and measurements shall be performed in conformity with appendix 1 or alternatively with point 4.2.6.2. of EN 15194:2009.

- 3.2. Test procedure to measure the maximum continuous rated power

The maximum continuous rated power shall be measured according to the test procedure set out in appendix 3.

- 3.3. Test procedure to measure the maximum peak power

- 3.3.1. Acceptable range maximum peak power as compared with maximum continuous rated power

The maximum peak power shall be $\leq 1,6 \times$ maximum continuous rated power, measured as mechanical output power at the shaft of the motor unit.

- 3.3.2. Tolerances

The maximum continuous rated and peak power values may deviate by $\pm 5\%$ from the result of the measurements set out in appendix 3.

- 3.3.3. Power correction factors

- 3.3.3.1. Definition of factor α_1 and α_2

- 3.3.3.1.1. α_1 and α_2 shall be factors by which the torque and power measured are to be multiplied in order to determine the torque and power of an engine, taking account of the efficiency of the transmission (factor α_2) used during the tests and in order to bring them within the reference atmospheric conditions specified in point 3.2.1 (factor α_1). The power correction formula is as follows:

Equation Ap 4-1:

$$P_0 = \alpha_1 \times \alpha_2 \times P$$

where:

Status: Point in time view as at 16/12/2013.

Changes to legislation: There are currently no known outstanding effects for the Commission Delegated Regulation (EU) No 134/2014. (See end of Document for details)

- P_0 = the corrected power (i.e. the power under the reference conditions at the end of the crankshaft);
- α_1 = the correction factor for reference atmospheric conditions and measurement uncertainties shall be 1,10;
- α_2 = the correction factor for the efficiency of the transmission and shall be 1,05, unless the real values of the drive train losses are determined;
- P = the power measured (power observed) at the tyre.

3.3.4. Atmospheric test conditions

3.3.4.1. During the test, the atmospheric conditions shall lie within the following range:

$$278,2 \text{ K} < T < 318,2 \text{ K}$$

where:

T = test temperature (K)

3.3.5. Test preparations

3.3.5.1. The test vehicle shall be mounted on a test bench.

3.3.5.2. The test vehicle shall be powered by its corresponding battery. If several types of batteries are released for the vehicle, the battery with maximum capacity shall be used.

3.3.5.3. The propulsion batter(y)/(ies) shall be fully charged.

3.3.5.4. One motor of the test bench shall be attached to the crank or crank axis of the test vehicle (test-bench crank motor). This motor shall be variable as regards rotation speed and torque to simulate the driving actions of the driver. The test-bench crank motor shall reach a rotation frequency of 90 min^{-1} and a maximum torque of 50 Nm to cover the typical performance ranges of drivers.

3.3.5.5. A brake or a motor shall be attached to a drum below the rear wheel of the test vehicle to simulate the losses and inertia of the vehicle.

3.3.5.6. For vehicles equipped with a motor driving the front wheel, an additional brake or an additional motor shall be attached to a drum below the front wheel, simulating the losses and inertia of the vehicle.

3.3.5.7. If the assistance level of the vehicle is variable, it shall be set to maximum assistance.

3.3.5.8. Peripheral devices powered by the power supply of the vehicle shall be dismantled or switched off. If such devices are necessary for motor assistance, they may remain powered on if the manufacturer has sufficiently justified this to the technical service and to the satisfaction of the approval authority.

3.3.5.9. Prior to start of the measurement, the cadence of the test-bench crank motor shall be swept from low to high cadence until a maximum mechanical output power is reached. For this preconditioning, a medium vehicle gear shall be used at an average test-bench crank motor torque of 25 Nm.

3.3.5.10. Subsequently, the test-bench crank motor torque shall be varied to reach the maximum mechanical output of the motor. After adjustment of the test-bench crank motor torque, the gear of the vehicle shall be adjusted for maximum output power. The test-bench crank motor conditions with maximum vehicle output power shall be reported and used for measuring the maximum power. They shall be monitored during the measurement. For this point of operation, the brakes/motors of the test bench for

Status: Point in time view as at 16/12/2013.

Changes to legislation: There are currently no known outstanding effects for the Commission Delegated Regulation (EU) No 134/2014. (See end of Document for details)

the front and the rear wheel shall be adjusted so that the rotation frequencies remain constant.

3.4. Test procedure to measure and calculate the maximum motor power

3.4.1. The maximum power shall be measured for five minutes (maximum five minute power). If the power is not constant, the average power during the five minute measurement shall be taken as the maximum five minute power.

3.4.2. The maximum motor power of the vehicle shall be calculated from the sum of the mechanical brake motor powers minus the mechanical input power of the test-bench crank motor.

3.4.3. Data to be recorded

The data to be recorded are those set out in the template of the test report referred to in Article 32(1) of Regulation (EU) No 168/2013.

3.5. Test procedure to measure the switch-off distance

After stopping with pedalling, the assistance of the motor shall switch off in a driving distance ≤ 3 m. The testing vehicle speed is 90 % of the maximum assistance speed. The measurements shall be taken in accordance with EN 15194:2009.

3.5. Test procedure to measure the maximum assistance factor

3.5.1. The ambient temperature shall be between 278,2 K and 318,2 K.

3.5.2. The test vehicle shall be powered by its corresponding propulsion battery. The propulsion battery with maximum capacity shall be used for this test procedure.

3.5.3. The battery shall be fully charged using the charger to be specified by the vehicle manufacturer.

3.5.4. One motor of the test bench shall be attached to the crank or crank axis of the test vehicle. This test bench crank motor shall simulate the driving action of the rider and shall be capable of running variable rotation speeds and torques. It shall reach a rotation frequency of 90 rpm and a maximum continuous rated torque of 50 Nm.

3.5.5. A brake or a motor simulating the losses and inertia of the vehicle shall be attached to a drum below the rear wheel of the test vehicle.

3.5.6. For vehicles equipped with a motor driving the front wheel, an additional brake or an additional motor shall be attached to a drum below the front wheel, simulating the losses and inertia of the vehicle.

3.5.7. If the assistance level of the vehicle is variable, it has to be set to maximum assistance.

3.5.8. The following points of operation shall be tested:

TABLE AP4-1

Operation points to test the maximum assistance factor

Status: Point in time view as at 16/12/2013.

Changes to legislation: There are currently no known outstanding effects for the Commission Delegated Regulation (EU) No 134/2014. (See end of Document for details)

Point of operation	Simulated rider input power (+/- 10 %) in (W)	Target vehicle speed^a (+/- 10 %) in (km/h)	Desired pedalling cadence^b in (rpm)
A	80	20	60
B	120	35	70
C	160	40	80

a If the target vehicle speed cannot be reached, the measurement shall be performed at the maximum vehicle speed reached

b select gear closest to required rpm rate for the point of operation

3.5.9. The maximum assistance factor shall be calculated according to the following formula:

Equation Ap4-1:

$$\text{Assistance factor} = \frac{\text{mechanical motor power of test vehicle}}{\text{simulated rider input power}}$$

where:

The mechanical motor power of the test vehicle shall be calculated from the sum of the mechanical brake motor power minus the mechanical input power of the test bench crank motor (in W).

ANNEX XI

Vehicle propulsion family with regard to environmental performance demonstration tests

1. Introduction

- 1.1. In order to alleviate the test burden on manufacturers when demonstrating the environmental performance of vehicles these may be grouped as a vehicle propulsion family. One or more parent vehicles shall be selected from this group of vehicles by the manufacturer to the satisfaction of the approval authority that shall be used to demonstrate environmental performance test types I to VIII. Parent vehicles to demonstrate test type IX on sound level shall follow the requirements set out in the UNECE regulations referred to in point 2 of Annex IX.
- 1.2. An L-category vehicle may continue to be regarded as belonging to the same vehicle propulsion family provided that the vehicle variant, version, propulsion, pollution-control system and OBD parameters listed in Table 11-1 are identical or remain within the prescribed and declared tolerances.
- 1.3. Vehicle and propulsion family attribution with regard to environmental tests

For the environmental test types I to XIII a representative parent vehicle shall be selected within the boundaries set by the classification criteria laid down in point 3.

2. Definitions

- 2.1. 'variable cam phasing or lift' means allowing the lift, the opening and closing duration or timing of the intake or exhaust valves to be modified while the engine is in operation;
- 2.2. 'communication protocol' means a system of digital message formats and rules for messages exchanged in or between computing systems or units;
- 2.3. 'common rail' means a fuel supply system to the engine in which a common high pressure is maintained;
- 2.4. 'intercooler' means a heat exchanger that removes waste heat from the compressed air by a charger before entering into the engine, thereby improving volumetric efficiency by increasing intake air charge density;
- 2.5. 'electronic throttle control' (ETC) means the control system consisting of sensing of driver input via the accelerator pedal or handle, data processing by the control unit(s), resulting actuation of the throttle and throttle position feedback to the control unit in order to control the air charge to the combustion engine;
- 2.6. 'boost control' means a device to control the boost level produced in the induction system of a turbocharged or supercharged engine;
- 2.7. 'SCR system' means a system capable of converting gaseous pollutants into harmless or inert gases by injecting a consumable reagent, which is a reactive substance to reduce tailpipe emissions and which is adsorbed onto a catalytic converter;
- 2.8. 'lean NO_x adsorber' means a storage of NO_x fitted into the exhaust system of a vehicle which is purged by the release of a reactant in the exhaust flow;

Status: Point in time view as at 16/12/2013.

Changes to legislation: There are currently no known outstanding effects for the Commission Delegated Regulation (EU) No 134/2014. (See end of Document for details)

- 2.9. ‘cold-start device’ means a device that temporarily enriches the air/fuel mixture of the engine, thus assisting the engine to start;
- 2.10. ‘starting aid’ means a device which assists engine start up without enrichment of the air/fuel mixture such as glow plugs, injection timing and spark delivery adaptations;
- ‘exhaust gas recirculation (EGR) system’ means part of the exhaust gas flow led back to or remaining in the combustion chamber of an engine in order to lower the combustion temperature;
3. **Classification criteria**
- 3.1. Test types I, II, V, VII and VIII (‘X’ in Table 11-1 means ‘applicable’)

TABLE 11-1

Classification criteria propulsion family with regard to test types I, II, V, VII and VIII

#	Classification criteria description	Test type I	Test type II	Test type V	Test type VII	Test type VIII	
						Stage I	Stage II
1.	Vehicle						
1.1.	category;	X	X	X	X	X	X
1.2.	sub-category;	X	X	X	X	X	X
1.3.	the inertia of a vehicle variant(s) or version(s) within two inertia categories above or below the nominal inertia category;	X		X	X	X	X
1.4.	overall gear ratios (+/- 8 %);	X		X	X	X	X

2. Propulsion family characteristics

Explanatory notes:

a maximum 30 % acceptable for test type VIII

b Only for vehicles equipped with storage for gaseous fuel

Status: Point in time view as at 16/12/2013.

Changes to legislation: There are currently no known outstanding effects for the Commission Delegated Regulation (EU) No 134/2014. (See end of Document for details)

2.1.	number of engines or electric motors;	X	X	X	X	X	X
2.2.	hybrid operation mode(s) (parallel / sequential / other);	X	X	X	X	X	X
2.3.	number of cylinders of the combustion engine;	X	X	X	X	X	X
2.4.	engine capacity (+/- 2 %) ^a of the combustion engine;	X	X	X	X	X	X
2.5.	number and control (variable cam phasing or lift) of combustion engine valves;	X	X	X	X	X	X
2.6.	monofuel / bifuel / flex fuel H ₂ NG / multifuel;	X	X	X	X	X	X
2.7.	fuel system (carburettor / scavenging port / port fuel injection /	X	X	X	X	X	X

Explanatory notes:

a maximum 30 % acceptable for test type VIII

b Only for vehicles equipped with storage for gaseous fuel

Status: Point in time view as at 16/12/2013.

Changes to legislation: There are currently no known outstanding effects for the Commission Delegated Regulation (EU) No 134/2014. (See end of Document for details)

	direct fuel injection / common rail / pump-injector / other);						
2.8.	fuel storage ^b ;					X	X
2.9.	type of cooling system of combustion engine;	X	X	X	X	X	X
2.10.	combustion cycle (PI / CI / two-stroke / four-stroke / other);	X	X	X	X	X	X
2.11.	intake air system (naturally aspirated / charged (turbocharger / super-charger) / intercooler / boost control) and air induction control (mechanical throttle / electronic throttle control / no throttle);	X	X	X	X	X	X
3.	Pollution control system characteristics						
3.1.	propulsion exhaust (not)	X	X	X	X		X

Explanatory notes:

a maximum 30 % acceptable for test type VIII

b Only for vehicles equipped with storage for gaseous fuel

Status: Point in time view as at 16/12/2013.

Changes to legislation: There are currently no known outstanding effects for the Commission Delegated Regulation (EU) No 134/2014. (See end of Document for details)

	equipped with catalytic converter(s);						
3.1.	catalytic converter(s) type;	X	X	X	X		X
3.1.1.	number and elements of catalytic converters;	X	X	X	X		X
3.1.2.	size of catalytic converters (volume of monolith(s) +/- 15 %);	X	X	X	X		X
3.1.3.	operation principle of catalytic activity (oxidising, three-way, heated, SCR, other.);	X	X	X	X		X
3.1.4.	precious metal load (identical or higher);	X	X	X	X		X
3.1.	precious metal ratio (+/- 15 %);	X	X	X	X		X
3.1.5.	substrate (structure and material);	X	X	X	X		X

Explanatory notes:

a maximum 30 % acceptable for test type VIII

b Only for vehicles equipped with storage for gaseous fuel

Status: Point in time view as at 16/12/2013.

Changes to legislation: There are currently no known outstanding effects for the Commission Delegated Regulation (EU) No 134/2014. (See end of Document for details)

3.1.6.	cell density;	X	X	X	X		X
3.1.7.	type of casing for the catalytic converter(s);	X	X	X	X		X
3.2.	propulsion exhaust (not) equipped with particulate filter (PF);	X	X	X	X		X
3.2.1.	PF types;	X	X	X	X		X
3.2.2.	number and elements of PF;	X	X	X	X		X
3.2.3.	size of PF (volume of filter element +/- 10 %);	X	X	X	X		X
3.2.4.	operation principle of PF (partial / wall-flow / other);	X	X	X	X		X
3.2.5.	active surface of PF;	X	X	X	X		X
3.3.	propulsion (not) equipped with periodically regenerating system;	X	X	X	X		X
3.3.1.	periodically regenerating	X	X	X	X		X

Explanatory notes:

a maximum 30 % acceptable for test type VIII

b Only for vehicles equipped with storage for gaseous fuel

Status: Point in time view as at 16/12/2013.

Changes to legislation: There are currently no known outstanding effects for the Commission Delegated Regulation (EU) No 134/2014. (See end of Document for details)

	system type;						
3.3.2.	operation principle of periodically regenerating system;	X	X	X	X		X
3.4.	propulsion (not) equipped with selective catalytic converter reduction (SCR) system;	X	X	X	X		X
3.4.1.	SCR system type;	X	X	X	X		X
3.4.2.	operation principle of periodically regenerating system;	X	X	X	X		X
3.5.	propulsion (not) equipped with lean NO _x trap / absorber;	X	X	X	X		X
3.5.1.	lean NO _x trap / absorber type;	X	X	X	X		X
3.5.2.	operation principle of lean NO _x trap / absorber;	X	X	X	X		X
3.6.	propulsion (not)	X	X	X	X		X

Explanatory notes:

a maximum 30 % acceptable for test type VIII

b Only for vehicles equipped with storage for gaseous fuel

Status: Point in time view as at 16/12/2013.

Changes to legislation: There are currently no known outstanding effects for the Commission Delegated Regulation (EU) No 134/2014. (See end of Document for details)

	equipped with a cold-start device or starting aid device(s);						
3.6.1.	cold-start or starting aid device type;	X	X	X	X		X
3.6.2.	operation principle of cold start or starting aid device(s);	X	X	X	X	X	X
3.6.3.	Activation time of cold-start or starting aid device(s) and / or duty cycle (only limited time activated after cold start / continuous operation);	X	X	X	X	X	X
3.7.	propulsion (not) equipped with O ₂ sensor for fuel control;	X	X	X	X	X	X
3.7.1.	O ₂ sensor types;	X	X	X	X	X	X
3.7.2.	operation principle	X	X	X	X	X	X

Explanatory notes:

a maximum 30 % acceptable for test type VIII

b Only for vehicles equipped with storage for gaseous fuel

Status: Point in time view as at 16/12/2013.

Changes to legislation: There are currently no known outstanding effects for the Commission Delegated Regulation (EU) No 134/2014. (See end of Document for details)

	of O ₂ sensor (binary / wide range / other);						
3.7.3.	O ₂ sensor interaction with closed-loop fuelling system (stoichiometry / lean or rich operation);	X	X	X	X	X	X
3.8.	propulsion (not) equipped with exhaust gas recirculation (EGR) system;	X	X	X	X		X
3.8.1.	EGR system types;	X	X	X	X		X
3.8.2.	operation principle of EGR system (internal / external);	X	X	X	X		X
3.8.3.	maximum EGR rate (+/- 5 %);	X	X	X	X		X

Explanatory notes:

a maximum 30 % acceptable for test type VIII

b Only for vehicles equipped with storage for gaseous fuel

3.2. Test types III and IV ('X' in Table 11-2 means 'applicable')

TABLE 11-2

Classification criteria propulsion family with regard to test types III

Status: Point in time view as at 16/12/2013.

Changes to legislation: There are currently no known outstanding effects for the Commission Delegated Regulation (EU) No 134/2014. (See end of Document for details)

#	Classification criteria description	Test type III	Test type IV
1.	Vehicle		
1.1.	Category;	X	X
1.2.	Subcategory;		X
2.	System		
2.1.	propulsion (not) equipped with crankcase ventilation system;	X	
2.1.1.	crankcase ventilation system type;	X	
2.1.2.	operation principle of crank case ventilation system (breather / vacuum / overpressure);	X	
2.2.	propulsion (not) equipped with evaporative emission control system;		X
2.2.1.	evaporative emission control system type;		X
2.2.2.	operation principle of evaporative emission control system (active / passive / mechanically or electronically controlled);		X
2.2.3.	identical basic principle of fuel/ air metering (e.g. carburettor / single point injection / multi point injection / engine speed density through MAP/ mass airflow);		X
2.2.4.	identical material of the fuel tank and liquid fuel hoses is identical;		X
2.2.5.	the fuel storage volume is within a range of +/- 50 %;		X

Status: Point in time view as at 16/12/2013.

Changes to legislation: There are currently no known outstanding effects for the Commission Delegated Regulation (EU) No 134/2014. (See end of Document for details)

2.2.	the setting of the fuel storage relief valve is identical;		X
2.2.6.	identical method of storage of the fuel vapour (i.e. trap form and volume, storage medium, air cleaner (if used for evaporative emission control) etc.);		X
2.2.7.	identical method of purging of the stored vapour (e.g. air flow, purge volume over the driving cycle);		X
2.2.8.	identical method of sealing and venting of the fuel metering system;		X

5. Extension of type-approval regarding test type IV

5.1. The type-approval shall be extended to vehicles equipped with a control system for evaporative emissions which meet the evaporative emission control family classification criteria listed in point 5.3. The worst-case vehicle with regard to the cross-section and approximate hose length shall be tested as a parent vehicle.

5.2. The manufacturer may request to use one of the following approaches based on a 'certification by design' strategy to extend the approval for evaporative emissions:

5.2.1. Carry-across approach

5.2.1.1. if the vehicle manufacturer has certified a fuel tank of generic shape ('parent fuel tank'), these test data may be used to certify 'by design' any other fuel tank provided that it is designed with the same characteristics as regards material (including additives), method of production and average wall thickness.

5.2.1.2. if a fuel tank manufacturer has certified the material (including additives) of a 'parent' fuel tank on the basis of a complete permeability or permeation test, the vehicle manufacturer may use these test data to certify its fuel tank by design, provided it is designed with the same characteristics as regards material (including additives), method of production and average wall thickness.

5.2.2. Worst-case configuration approach

If the vehicle manufacturer has successfully carried out permeability or permeation testing on a worst-case fuel tank configuration, these test data may be used to certify by design other fuel tanks which are otherwise similar in terms of material (including additives), fuel pump plate and filler cap/neck. The worst-case configuration shall be the fuel tank design with the thinnest walls or the smallest interior surface area.

Status: Point in time view as at 16/12/2013.

Changes to legislation: There are currently no known outstanding effects for the Commission Delegated Regulation (EU) No 134/2014. (See end of Document for details)

ANNEX XII

Amendment of part A of Annex V to Regulation (EU) No 168/2013

1. Part A of Annex V to Regulation (EU) No 168/2013 is replaced by the following:

(A) Environmental tests and requirements

L-category vehicles may be type-approved only if they comply with the following environmental requirements:

Test type	Description	Requirements: limit values	Subclassification criteria in addition to Article 2 and Annex I	Requirements: test procedures
I	Tailpipe emissions after cold start	Annex VI (A)	Point 4.3 of Annex II to Commission Delegated Regulation (EU) No 134/2014	Annex II to Commission Delegated Regulation (EU) No 134/2014
II	— PI or Hybrid ⁽⁵⁾ equipped with PI: emissions at idling and increased idling speed — CI or Hybrid with CI engine: free acceleration test	Directive 2009/40/EC ⁽⁶⁾	Point 4.3 of Annex II to Commission Delegated Regulation (EU) No 134/2014	Annex III to Commission Delegated Regulation (EU) No 134/2014
III	Emissions of crankcase gases	Zero emission, closed crankcase. Crankcase emissions shall not be discharged directly into the ambient atmosphere	Point 3.2 of Annex XI to Commission Delegated Regulation (EU) No 134/2014	Annex IV to Commission Delegated Regulation (EU) No 134/2014

Status: Point in time view as at 16/12/2013.

Changes to legislation: There are currently no known outstanding effects for the Commission Delegated Regulation (EU) No 134/2014. (See end of Document for details)

		from any vehicle throughout its useful life.		
IV	Evaporative emissions	Annex VI (C)	Point 3.2 of Annex XI to Commission Delegated Regulation (EU) No 134/2014	Annex V to Commission Delegated Regulation (EU) No 134/2014
V	Durability of pollution control devices	Annexes VI and VII	SRC-LeCV: point 2 of Appendix 1 to Annex VI to Commission Delegated Regulation (EU) No 134/2014 USA EPA AMA: point 2.1 of Appendix 2 to Annex VI to Commission Delegated Regulation (EU) No 134/2014	Annex VI to Commission Delegated Regulation (EU) No 134/2014
VI	A test-type VI has not been attributed	Not applicable	Not applicable	Not applicable
VII	CO ₂ emissions, fuel and/or electric energy consumption and electric range	Measurement and reporting, no limit value for type- approval purposes	Point 4.3 of Annex II to Commission Delegated Regulation (EU) No 134/2014	Annex VII to Commission Delegated Regulation (EU) No 134/2014
VIII	OBD environmental tests	Annex VI (B)	Point 4.3 of Annex II to Commission Delegated Regulation (EU) No 134/2014	Annex VIII to Commission Delegated Regulation (EU) No 134/2014
IX	Sound level	Annex VI (D)	When UNECE regulations Nos 9, 41, 63 or 92 replace the EU proprietary requirements set out in the delegated act on environmental and propulsion	Annex IX to Commission Delegated Regulation (EU) No 134/2014

Status: Point in time view as at 16/12/2013.

Changes to legislation: There are currently no known outstanding effects for the Commission Delegated Regulation (EU) No 134/2014. (See end of Document for details)

		performance requirements, the (sub-) classification criteria laid down in those UNECE regulations (Annex 6) shall be selected with reference to test type IX sound level tests.	
--	--	---	--

Status: Point in time view as at 16/12/2013.

Changes to legislation: There are currently no known outstanding effects for the Commission Delegated Regulation (EU) No 134/2014. (See end of Document for details)

- (1) [OJ L 60, 2.3.2013, p. 52.](#)
- (2) Council Decision 97/836/EC of 27 November 1997 with a view to accession by the European Community to the Agreement of the United Nations Economic Commission for Europe concerning the adoption of uniform technical prescriptions for wheeled vehicles, equipment and parts which can be fitted to or be used on wheeled vehicles and the conditions for reciprocal recognition of approvals granted on the basis of these prescriptions ('Revised 1958 Agreement') ([OJ L 346, 17.12.1997, p. 78](#)).
- (3) [OJ L 226, 18.8.1997, p. 1.](#)
- (4) 'Measurement procedure for two-wheel motorcycles equipped with a positive or compression ignition engine with regard to the emissions of gaseous pollutants, CO₂ emissions and fuel consumption (UN document reference ECE/TRANS/180/Add2e of 30 August 2005)' including amendment 1 (UNECE document reference ECE/TRANS/180a2a1e of 29 January 2008).
- (5) The WMTC stage 2 is equal to the WMTC stage 1 amended by corrigendum 2 of addendum 2 (ECE/TRANS/180a2c2e of 9 September 2009) and corrigendum 1 of amendment 1 (ECE/TRANS/180a2a1c1e of 9 September 2009).
- (6) In addition, the corrigenda and amendments identified in the environmental effect study referred to in Article 23 of Regulation (EU) No 168/2013 will be taken into account, as well as corrigenda and amendments proposed and adopted by UNECE WP29 as continuous improvement of the world-harmonised test cycle for L-category vehicles.
- (7) As provided for in this Regulation in the version applicable to the type-approval of that vehicle.
- (8) [OJ L 141, 6.6.2009, p. 12.](#)
- (9) Mean value of G20 and G25 reference fuels at 288,2 K (15 °C).
- (10) [OJ L 317, 14.11.2012, p. 1.](#)
- (11) The test may be carried out in temperature-controlled test chambers where the atmospheric conditions can be controlled.
- (12) The torque measuring device shall be calibrated in order to take account of frictional losses. This accuracy may be $\pm 2\%$ for the measurements carried out at power levels less than 50 % of the maximum value. It will in all cases be $\pm 1\%$ for the measurement maximum torque.
- (13) The complete air intake system shall be fitted as provided for the intended application:
 - where there is a risk of an appreciable effect on the engine power,
 - in the case of two-stroke engines,
 - when the manufacturer requests that this should be done. In other cases, an equivalent system may be used and a check should be made to ascertain that the intake pressure does not differ by more than 100 Pa from the limit specified by the manufacturer for a clean air filter.
- (14) Minimum power of the generator: the power of the generator shall be no more than that required to operate accessories which are indispensable for the operation of the engine. If the connection of a battery is necessary, a fully-charged battery in good order shall be used.

Status:

Point in time view as at 16/12/2013.

Changes to legislation:

There are currently no known outstanding effects for the Commission Delegated Regulation (EU) No 134/2014.