

Commission Implementing Regulation (EU) 2016/1240 of 18 May 2016 laying down rules for the application of Regulation (EU) No 1308/2013 of the European Parliament and of the Council with regard to public intervention and aid for private storage (Text with EEA relevance)

COMMISSION IMPLEMENTING REGULATION (EU) 2016/1240

of 18 May 2016

laying down rules for the application of Regulation (EU) No 1308/2013 of the European Parliament and of the Council with regard to public intervention and aid for private storage

(Text with EEA relevance)

THE EUROPEAN COMMISSION,

Having regard to the Treaty on the Functioning of the European Union,

Having regard to Regulation (EU) No 1308/2013 of the European Parliament and of the Council of 17 December 2013 establishing a common organisation of the markets in agricultural products and repealing Council Regulations (EEC) No 922/72, (EEC) No 234/79, (EC) No 1037/2001 and (EC) No 1234/2007⁽¹⁾, and in particular Article 20(a), (b), (d), (e), (i), (j), (k), (l), (m), (n) and (o), and Article 223(3)(a), (b) and (c) thereof,

Having regard to Regulation (EU) No 1306/2013 of the European Parliament and of the Council of 17 December 2013 on the financing, management and monitoring of the common agricultural policy and repealing Council Regulations (EEC) No 352/78, (EC) No 165/94, (EC) No 2799/98, (EC) No 814/2000, (EC) No 1290/2005 and (EC) No 485/2008⁽²⁾, and in particular Article 62(2) (a), (b), (c) and (i), and Article 64(7)(a) thereof,

Having regard to Council Regulation (EU) No 1370/2013 of 16 December 2013 determining measures on fixing certain aids and refunds related to the common organisation of the markets in agricultural products⁽³⁾, and in particular Article 2(3) and Article 3(4) thereof,

Whereas:

- (1) Regulation (EU) No 1308/2013 replaced Council Regulation (EC) No 1234/2007⁽⁴⁾ and lays down new rules regarding public intervention and aid for private storage. It also empowers the Commission to adopt delegated and implementing acts in that respect. In order to ensure the smooth functioning of the public intervention and aid for private storage schemes in the new legal framework, certain rules have to be adopted by means of such acts. Those acts should replace Commission Regulations (EEC) No 3427/87⁽⁵⁾, (EEC) No 2351/91⁽⁶⁾, (EC) No 720/2008⁽⁷⁾, (EC) No 826/2008⁽⁸⁾, (EC) No 1130/2009⁽⁹⁾ and (EU) No 1272/2009⁽¹⁰⁾. Those Regulations are repealed by Commission Delegated Regulation (EU) 2016/1238⁽¹¹⁾.
- (2) Article 11 of Regulation (EU) No 1308/2013 provides that public intervention applies in respect of common wheat, durum wheat, barley, maize, paddy rice, fresh or chilled

Status: Point in time view as at 07/02/2018.

Changes to legislation: There are currently no known outstanding effects for the Commission Implementing Regulation (EU) 2016/1240. (See end of Document for details)

meat of the beef and veal sector, butter and skimmed milk powder in accordance with the conditions set out in that Regulation.

- (3) Article 17 of Regulation (EU) No 1308/2013 provides that aid for private storage may be granted in respect of white sugar, olive oil, flax fibre, fresh or chilled meat of bovine animals aged eight months or more, butter, cheese, skimmed milk powder, pigmeat, and sheepmeat and goatmeat in accordance with the conditions set out in that Regulation.
- (4) Regulation (EU) No 1370/2013 lays down rules concerning public intervention prices, quantitative limitations for buying-in into public intervention and the establishment of the amount of aid for private storage.
- (5) In order to simplify and improve the effectiveness of the management and control mechanisms related to the public intervention and aid for private storage schemes, common rules for all the products listed in Articles 11 and 17 of Regulation (EU) No 1308/2013 should respectively be laid down.
- (6) In accordance with Article 13(1) of Regulation (EU) No 1308/2013, the Commission may decide that buying in of durum wheat, barley, maize and paddy rice is to take place if the market situation so requires. Public intervention may also be opened for beef if the average market price is over a representative period below 85 % of the reference threshold set out in Article 7(1) of Regulation (EU) No 1308/2013. In such cases buying-in takes place by means of tendering procedures.
- (7) In accordance with Article 4(1) of Regulation (EU) No 1370/2013, the Commission may establish the amount of aid for private storage for the products listed in Article 17 of Regulation (EU) No 1308/2013 either by a tendering procedure or by fixing the aid in advance.
- (8) To make the public intervention and aid for private storage schemes work efficiently, the operators should use the method made available by the paying agency with regard to the procedure for submitting offers, tenders and applications.
- (9) In order to ensure proper management of the schemes, rules should be established on intervention at a fixed price, the tendering procedures for buying-in into intervention, sales from intervention or establishing the maximum amount of aid for private storage, and the aid for private storage fixed in advance as well as the submission and admissibility of tenders, offers and applications.
- (10) In order to improve the efficiency of the way public intervention operates, by discontinuing the use of small storage facilities which may be spread throughout a region, a minimum capacity of storage should be fixed for the intervention storage places, but should not be applicable in case where a storage place has ready access to a river, sea or railway connection.
- (11) Since products covered by the public intervention and aid for private storage schemes have a different nature as to production or harvest time and storage requirements, specific conditions concerning their eligibility should be provided for.
- (12) For a sound management of the public intervention and aid for private storage schemes, it is necessary to fix a minimum quantity below which the paying agency cannot accept

Status: Point in time view as at 07/02/2018.

Changes to legislation: There are currently no known outstanding effects for the Commission Implementing Regulation (EU) 2016/1240. (See end of Document for details)

an offer or a tender, both for buying-in and sales, or decide whether to fix or not the maximum amount of aid for private storage. However, if the conditions and practices of the wholesale trade or environmental rules in force in a Member State justify the application of minimum quantities larger than those laid down in this Regulation, the paying agency concerned should be entitled to require such larger minimum quantities for buying-in at fixed price.

- (13) In order to guarantee the seriousness of the offer or tender for intervention and to ensure that the measure will have its desired effect on the market, both in the case of intervention at fixed price and in the case of a tendering procedure, the level of the security should be established.
- (14) To ensure an effective management of the public intervention scheme, notifications on submitted offers and tenders should be provided for between Member States and the Commission. Measures should be introduced to respect the quantitative limitations fixed in Article 3 of Regulation (EU) No 1370/2013.
- (15) On the basis of the offers and tenders received a maximum buying-in price or a maximum amount of aid for private storage may be fixed. However, situations might arise on the market in which economic or other aspects make it necessary not to fix such a price or aid and to reject all the tenders received.
- (16) In order to guarantee a clear and effective functioning of the public intervention scheme, it is necessary to lay down the general rules concerning the issuance of the delivery order and the delivery of the products to the storage place designated by the paying agency. In addition, given the specificities of the sectors of cereals and rice as well as beef and butter and skimmed milk powder, it is necessary to lay down specific rules for those sectors.
- (17) With a view to the proper management of intervention stocks in storage and given the specificities of the sectors of cereals and rice, the obligations of the Member States should be specified as regards the maximum distance to the place of storage and the costs to be borne when this distance is exceeded.
- (18) In order to apply the common rules of Commission Delegated Regulation (EU) No 907/2014⁽¹²⁾, it is appropriate to provide that the checks on products during storage have to be carried out as laid down in Article 3 of that Regulation. A takeover record should be issued on the basis of those checks and analyses.
- (19) In order to ensure good quality of products stored under public intervention, in case the products do not fulfil the applicable eligibility requirements, it should be provided for an obligation of the operator to take back the products and bear all the costs during the period the products have been stored in the storage places.
- (20) Where deboning is required for beef, it is necessary to lay down special rules for that sector to complement the general ones.
- (21) Rules should be established for payments, subject to price adjustment related to the quality of the product or to the location of the storage place. In order to give the operators the time to adapt to the new public intervention scheme, some conditions relating to

Status: Point in time view as at 07/02/2018.

Changes to legislation: There are currently no known outstanding effects for the Commission Implementing Regulation (EU) 2016/1240. (See end of Document for details)

price adjustment with regard to cereals should be applicable only from the start of the 2017/18 marketing year.

- (22) In order to give the necessary information on the characteristics of the products and on the site where they are stored, notices of invitation to tender should be drawn up and published by the paying agency holding intervention stocks available for sale. To this end, it should be provided for that a reasonable time period should elapse between the date of such publication and the first closing date for the submission of tenders.
- (23) On the basis of the tenders and of the situation on the Union market, the Commission should decide to fix or not a minimum intervention selling price. According to that decision, the paying agencies will accept or reject the tenders on products available for sale. Specific rules should be adopted for the allocation of beef, butter and skimmed milk powder.
- (24) In order to facilitate the sale of small quantities remaining in storage places in a Member State and to assure a sound management of the system, it is appropriate to provide that the paying agency, under its own responsibility, is entitled to open the tendering procedure for the resale of such quantities of intervention products, by applying *mutatis mutandis* the rules laid down in respect of tendering procedures opened by the Union, with a view to ensure equal access for all parties concerned. For the same reasons the paying agency should be authorised to put up for direct sale quantities which after checking by visual examination in the context of the annual stocktaking or during the inspection after taking into intervention may no longer be repackaged or are deteriorated.
- (25) To ensure that the aid for private storage scheme can be monitored properly, the information needed to conclude the storage contract should be specified as well as the obligations of the contracting parties and the conditions for placing into storage, in particular those enabling the competent authority responsible for checking storage operations to make an effective inspection of the storage conditions. The rules with regard to the contractual storage period should also be defined.
- (26) In order to ensure an efficient functioning of the aid for private storage scheme, it is necessary to lay down the general rules concerning the removal of the products from storage and the payment of aid for private storage. For butter and skimmed milk powder, given the specific nature of these products, special rules are necessary to complement the general ones.
- (27) When the amount of aid for private storage is fixed in advance, it is appropriate to provide for a reflection period in order to allow the market situation to be assessed before decisions on applications for aid are notified. Furthermore, where appropriate, provisions should be made for special measures applying in particular to pending applications to prevent excessive or speculative use of the private storage scheme. Such measures require swift action and the Commission should be empowered to act without applying the procedure referred to in Article 229(2) or (3) of Regulation (EU) No 1308/2013 and to take all necessary measures without delay.

Status: Point in time view as at 07/02/2018.

Changes to legislation: There are currently no known outstanding effects for the Commission Implementing Regulation (EU) 2016/1240. (See end of Document for details)

- (28) To protect the Union's financial interests, adequate control measures should be adopted to combat irregularities and fraud. These control measures should involve full administrative checking supplemented by on-the-spot checks. The scope, content, timing and reporting of such control measures should be specified so as to ensure an equitable and uniform approach between Member States.
- (29) Amounts unduly paid should be recovered in accordance with Commission Implementing Regulation (EU) No 908/2014⁽¹³⁾.
- (30) For an effective management of the public intervention and aid for private storage schemes, it is necessary to provide that the Member States inform the Commission periodically of the situation of stocks, of the products entering and leaving storage places and of the situation regarding prices and production for the products listed in Articles 11 and 17 of Regulation (EU) No 1308/2013.
- (31) The measures provided for in this Regulation are in accordance with the opinion of the Committee for the Common Organisation of the Agricultural Markets,

HAS ADOPTED THIS REGULATION:

TITLE I

GENERAL PROVISIONS

CHAPTER I

Introductory provision

Article 1

Scope

- 1 This Regulation lays down rules for the application of Regulation (EU) No 1308/2013 and Regulation (EU) No 1370/2013 as regards:
- a the buying-in and selling from public intervention of products listed in Article 11 of Regulation (EU) No 1308/2013;
 - b the granting of aid for private storage for products listed in Article 17 of Regulation (EU) No 1308/2013.
- 2 This Regulation shall apply without prejudice to specific provisions laid down in Implementing Regulations:
- a opening a tendering procedure for buying-in of products or opening the sale of products from intervention; or
 - b opening a tendering procedure or fixing the amount of aid for private storage in advance.

Status: Point in time view as at 07/02/2018.

Changes to legislation: There are currently no known outstanding effects for the Commission Implementing Regulation (EU) 2016/1240. (See end of Document for details)

CHAPTER II

General common rules

Article 2

Submission and admissibility of offers, tenders and applications

1 Operators shall lodge offers and tenders for public intervention as well as tenders and applications for aid for private storage using the method made available by the paying agency of the Member State concerned.

2 An offer, tender or application shall be admissible if it is submitted in the official language or one of the official languages of the Member State in which the offer, tender or application is submitted, and shall include, on a form made available by the paying agency, at least the following information:

- a the operator's name, address and VAT registration number in the Member State where the operator carries out his main activity;
- b the product, or type of product, covered with its relevant CN code, if applicable;
- c the quantity offered, tendered or applied for, subject to the minimum quantities laid down in Article 5, if applicable.

3 The offer, tender or application shall not include any additional conditions introduced by the operator other than those laid down in this Regulation or in the relevant Implementing Regulation opening the tendering procedure or fixing the amount of aid for private storage in advance.

4 Where the time limit for the submission of offers, tenders or applications is a public holiday, the offers, tenders or applications shall be submitted at the latest on the last working day preceding the public holiday.

5 Offers, tenders or applications submitted on a Saturday, Sunday or public holiday shall be deemed to be received by the paying agency on the first working day following the day on which they were submitted.

6 Offers, tenders or applications shall not be withdrawn or amended after their submission.

7 The paying agency shall register the admissible offers, tenders or applications and the quantities concerned on the day on which they are received.

8 The rights and obligations resulting from the acceptance of the offer, tender or application shall not be transferable.

Status: Point in time view as at 07/02/2018.

Changes to legislation: There are currently no known outstanding effects for the Commission Implementing Regulation (EU) 2016/1240. (See end of Document for details)

TITLE II

PUBLIC INTERVENTION

CHAPTER I

Specific rules related to public intervention

Article 3

Intervention storage places

1 Each intervention storage place ('storage place') shall have a minimum storage capacity of:

- a for cereals: 5 000 tonnes, 7 500 tonnes from the public intervention period 2017/18, 10 000 tonnes from the 2018/19 period, 15 000 tonnes from the 2019/20 period;
- b for rice: 5 000 tonnes, 7 500 tonnes from the public intervention period 2017/18, 10 000 tonnes from the 2018/19 period;
- c for butter and skimmed milk powder: 400 tonnes, 600 tonnes from the 2017 public intervention period, 800 tonnes from the 2018 period.

Member States with an average annual production of cereals of less than 20 million tonnes may continue to apply from the 2019/20 period a minimum storage capacity of 10 000 tonnes.

2 For the purposes of this Article, the 'minimum storage capacity' means a minimum capacity which may not be available permanently, but is readily achievable during the period when buying-in might take place.

3 A paying agency may derogate from paragraph 1 only where it demonstrates that the minimum storage capacity specified in that paragraph is not available and where the replacement storage places have ready access to a river, a sea or a railway connection.

Article 4

Establishing the eligibility of products

1 The eligibility of products for public intervention shall be established in accordance with the methods laid down in the following provisions:

- a for cereals: in Parts I, II, III and IV of Annex I;
- b for rice: in Part I of Annex II;
- c for beef: in Part I of Annex III;

[^{F1}d for butter: in Parts I and Ia of Annex IV to this Regulation;]

[^{F1}e for skimmed milk powder: in Parts I and Ia of Annex V to this Regulation.]

[^{F12} The methods to be used to determine the quality of cereals, butter and skimmed milk powder eligible for public intervention referred to in Annexes I, IV and V respectively, shall be those established by the latest versions of the relevant European or international standards, as the case may be, in force at least 6 months before the first day of the public intervention period as defined in Article 12 of Regulation (EU) No 1308/2013.]

Status: Point in time view as at 07/02/2018.

*Changes to legislation: There are currently no known outstanding effects for the
Commission Implementing Regulation (EU) 2016/1240. (See end of Document for details)*

Textual Amendments

- F1** Substituted by [Commission Implementing Regulation \(EU\) 2018/150 of 30 January 2018 amending Implementing Regulation \(EU\) 2016/1240 as regards methods for the analysis and quality evaluation of milk and milk products eligible for public intervention and aid for private storage.](#)

CHAPTER II

Buying-in of products into intervention

Section 1

General provisions

Article 5

Minimum quantities of products offered or tendered

- 1 The minimum quantity of products offered or tendered for buying-in shall be:
- a for common wheat, barley and maize: 160 tonnes;
 - b for durum wheat: 20 tonnes;
 - c for rice: 40 tonnes;
 - d for beef: 20 tonnes;
 - e for butter: 30 tonnes;
 - f for skimmed milk powder: 30 tonnes.

Member States with an average annual production of cereals of less than 20 million tonnes may decide to apply a minimum quantity of 120 tonnes for common wheat, barley and maize.

- 2 A paying agency may set a minimum quantity higher than that provided for in paragraph 1 if justified by the conditions and practices of the wholesale trade or environmental rules in force in the Member State concerned.

Article 6

Level of the security for buying-in of products

The level of the security required in accordance with Article 4(a) of Delegated Regulation (EU) 2016/1238 when submitting an offer or tender for the buying-in of products into public intervention shall be:

- (a) for cereals: EUR 20/tonne;
- (b) for rice: EUR 30/tonne;
- (c) for beef: EUR 300/tonne;
- (d) for butter: EUR 50/tonne;

Status: Point in time view as at 07/02/2018.

Changes to legislation: There are currently no known outstanding effects for the Commission Implementing Regulation (EU) 2016/1240. (See end of Document for details)

- (e) for skimmed milk powder: EUR 50/tonne.

Article 7

Submission and admissibility of offers and tenders

1 An offer or tender shall be admissible if it complies with the requirements laid down in Article 2 and, in the case of a tendering procedure, in the Implementing Regulation opening the tendering procedure referred to in Article 12. It shall also meet the following conditions:

- a it includes at least the following information:
 - (i) for rice, an indication of the type and variety;
 - (ii) except for beef, the place where the product is held at the time of the offer or tender;
 - (iii) for cereals and rice, the storage place for which the offer or tender is made;
 - (iv) for cereals and rice, the year of harvest and the area or areas of production in the Union;
 - (v) for butter and skimmed milk powder, the date of production;
 - (vi) for butter and skimmed milk powder, the name and approval number of the approved undertaking in which it was produced;
- b the operator has lodged a security in accordance with Article 4(a) of Delegated Regulation (EU) 2016/1238;
- c for cereals and rice, the operator has declared:
 - (i) that the products are of Union origin;
 - (ii) that the offer or tender refers to a homogeneous lot which, for rice, must comprise paddy rice of the same variety;
 - (iii) whether any post-harvest treatment has been carried out or not, and, where appropriate, the name of the product used, that it has been applied in conformity with the conditions of use, and that the product is authorised under Regulation (EC) No 1107/2009 of the European Parliament and of the Council⁽¹⁴⁾.

2 For products other than beef, the operator may request on the form referred to in Article 2(2) that the product be taken over at the storage place where it is held at the time the offer or tender is submitted provided that the storage place fulfils the requirements laid down in Article 7(1) of Delegated Regulation (EU) 2016/1238 and in Article 3 of this Regulation.

Article 8

Verification of offers and tenders by the paying agency

1 The paying agencies shall decide on the admissibility of offers and tenders on the basis of the requirements laid down in Articles 2 and 7.

Where the paying agency decides that an offer or tender is inadmissible, it shall inform the operator concerned within three working days of the receipt of the offer or tender.

Status: Point in time view as at 07/02/2018.

Changes to legislation: There are currently no known outstanding effects for the Commission Implementing Regulation (EU) 2016/1240. (See end of Document for details)

For offers, if the operator does not receive such information, the offer is considered as being admissible.

2 As regards cereals and rice, the declarations referred to in Article 7(1)(c) may be checked for compliance by administrative means after the paying agency has verified that the offers or tenders are admissible, if necessary with the assistance of the paying agency competent for the storage place indicated by the operator, in accordance with Article 57(2).

Article 9

Notifications of offers and tenders to the Commission

1 Member States shall notify the Commission of all admissible offers and tenders within the following time limits:

- a in the case of offers, notifications shall be submitted not later than 12.00 (Brussels time) each Tuesday and shall relate to the quantities of the products which, during the preceding week, have been the subject of an admissible offer, and of the related information.

When the quantities offered approach the limits fixed in Article 3(1) of Regulation (EU) No 1370/2013, the Commission shall inform Member States as of which date they shall notify the Commission on each working day.

As from that date, Member States shall notify the Commission, not later than 14.00 (Brussels time) each working day, of the quantities offered for intervention during the preceding working day.

- b in the case of tenders, the time limits laid down in the Implementing Regulation opening the tendering procedure shall apply.

2 The notifications provided for in points (a) and (b) of paragraph 1 shall not contain the operator's name, address and VAT registration number and, in the case of butter and skimmed milk powder, the name and approval number of the approved undertaking.

3 Where a Member State does not notify the Commission of an admissible offer or tender within the time limits referred to in points (a) and (b) of paragraph 1, it shall be deemed to have notified the Commission of a nil return.

Section 2

Buying-in at fixed price

Article 10

Submission of offers for buying-in of common wheat, butter and skimmed milk powder at fixed price

Offers may be submitted to the paying agency from the beginning of the public intervention periods laid down in Article 12 of Regulation (EU) No 1308/2013.

Status: Point in time view as at 07/02/2018.

Changes to legislation: There are currently no known outstanding effects for the Commission Implementing Regulation (EU) 2016/1240. (See end of Document for details)

Article 11

Measures for respecting the quantitative limitations

1 In order to comply with the quantitative limitations fixed in Article 3(1) of Regulation (EU) No 1370/2013, the Commission shall decide as provided for in Article 3(6)(a) of that Regulation:

- a to close intervention buying-in at fixed price;
- b where acceptance of the full quantity offered would lead to the maximum quantity being exceeded, to set an allocation coefficient applicable to the total quantity in the offers received and notified to the Commission from each operator on the day of the decision;
- c where appropriate, to reject pending offers submitted to the paying agencies of the Member States.

The Commission shall decide within two working days of the notification referred to in the first subparagraph of point (a) of Article 9(1), and within five working days of the notification referred to in the third subparagraph of point (a) of Article 9(1).

For the purposes of this Article, when a date of notification is a public holiday for the Commission the counting of the deadline shall start on the first working day after that public holiday. If such public holidays are included in the time period for the Commission's decision, only working days shall be counted.

2 By way of derogation from Article 2(6), an operator to whom an allocation coefficient as referred to in point (b) of paragraph 1 applies may withdraw his offer within five working days of the date of entry into force of the decision setting the allocation coefficient.

Section 3

Buying-in via a tendering procedure

Article 12

Tendering procedure

1 A tendering procedure for the buying-in of products referred to in Article 11 of Regulation (EU) No 1308/2013 shall be opened by way of an Implementing Regulation opening the tendering procedure, which shall contain, in particular, the following information:

- a the products covered, and:
 - (i) for rice, an indication of the type and variety;
 - (ii) for beef, whether the tender is for the bought-in carcasses to be deboned or for storage without deboning;
- b the period covered ('tendering period') and, if necessary, the different sub-periods during which the tenders can be submitted.

2 The Commission may open a tendering procedure for buying-in of beef by category and Member State, or region thereof, as provided for in Article 13(1)(c) of Regulation (EU) No 1308/2013, on the basis of the two most recent weekly market prices recorded. The Commission

Status: Point in time view as at 07/02/2018.

Changes to legislation: There are currently no known outstanding effects for the Commission Implementing Regulation (EU) 2016/1240. (See end of Document for details)

may close that tendering procedure, as provided for in Article 13(2) of that Regulation, on the basis of the most recent weekly market prices recorded.

3 If the Commission opens a restricted tendering procedure as referred to in Article 3(3) of Regulation (EU) No 1370/2013, the Implementing Regulation opening that procedure shall refer to the specific Member State or region(s) of a Member State covered by the tendering procedure.

4 With regard to rice, the tendering procedure may be restricted to specific varieties or one or more types of paddy rice, namely 'round grain rice', 'medium grain rice', 'long grain rice A' or 'long grain rice B', as defined in points (a), (b) or (c) of point I.2 of Part I of Annex II to Regulation (EU) No 1308/2013.

5 With regard to beef, the following rules shall apply:

- a the average market price by eligible category in a Member State or in a region thereof shall take account of the prices for qualities U, R and O, expressed in quality R3 using the conversion coefficients set out in Part II of Annex III in the Member State or the intervention region concerned;
- b the average market prices shall be recorded in accordance with Commission Regulation (EC) No 1249/2008⁽¹⁵⁾;
- c the average market price by eligible category in a Member State or a region thereof shall be the average of the market prices for all the qualities referred to in point (b), weighted by the proportion each quality represents in the total number of slaughterings in that Member State or region.

The United Kingdom shall consist of two intervention regions as follows:

- (i) region I: Great Britain;
- (ii) region II: Northern Ireland.

Article 13

Submission and admissibility of tenders

1 In addition to the general conditions laid down in Articles 2 and 7, a tender shall only be admissible if it indicates a proposed price in euro per unit of measurement of the product rounded to no more than two decimal places, exclusive of VAT.

In the case of cereals and rice, the price tendered per tonne of products shall be a price corresponding to the minimum quality for cereals defined in Part II of Annex I to Delegated Regulation (EU) 2016/1238 or to the standard quality for rice defined in Section A of Annex III to Regulation (EU) No 1308/2013, delivered to the storage place, not unloaded.

In the case of butter and skimmed milk powder, the tendered price shall be the price per 100 kg of products delivered to the loading bay of the storage place.

In the case of beef, tenders shall state the price quoted in accordance with Article 12(5) (a), expressed per tonne of products of quality R3, and if it relates to bone-in meat intended for deboning, or for storage without deboning.

2 Without prejudice to Article 15(2) of this Regulation, the price tendered shall not exceed the level of the public intervention price set out in Article 2(1) of Regulation (EU) No 1370/2013.

Status: Point in time view as at 07/02/2018.

Changes to legislation: There are currently no known outstanding effects for the Commission Implementing Regulation (EU) 2016/1240. (See end of Document for details)

Article 14

Decisions on the buying-in price

1 On the basis of the tenders notified in accordance with Article 9, the Commission shall decide:

- a not to fix a maximum buying-in price; or
- b to fix a maximum buying-in price.

2 The decision referred to in paragraph 1 shall be published in the *Official Journal of the European Union*.

Article 15

Individual decisions on tenders

1 Where no maximum buying-in price has been fixed, all tenders shall be rejected.

2 Where a maximum buying-in price has been fixed, the paying agency shall accept tenders which are equal to or lower than that amount. All the other tenders shall be rejected.

The paying agency shall only accept tenders that have been notified to the Commission in accordance with Article 9.

3 The paying agency shall take the decisions referred to in paragraphs 1 and 2 of this Article after the publication of the decision of the Commission referred to in Article 14(1).

The paying agency shall notify the operators of the outcome of their participation in the tendering procedure within three working days of the entry into force of that decision of the Commission.

This notification shall not be necessary when the tender is accepted, if the paying agency issues a delivery order as referred to in Article 17 within five working days of the entry into force of that decision of the Commission. In case of such acceptance, no further extension of the time limit for the issue of the delivery order, as referred to in the second subparagraph of Article 17(1), may be granted.

Article 16

Limitation of buying-in for beef

Where the paying agencies are offered beef in quantities greater than they are able to take over, they may limit the buying-in to the quantities they can take over in their territory or in one of their intervention regions referred to in Article 12(5).

Paying agencies shall ensure equal access for all parties concerned in the event of such limitation.

Status: Point in time view as at 07/02/2018.

Changes to legislation: There are currently no known outstanding effects for the Commission Implementing Regulation (EU) 2016/1240. (See end of Document for details)

Section 4

Deliveries and transport costs

Article 17

Delivery order

1 After the paying agency has checked the admissibility of the offer or tender in accordance with Articles 8 and 13, it shall issue the delivery order within five working days of the deadline referred to in the second subparagraph of Article 11(1) or of the entry into force of the decision referred to in Article 14(1).

The paying agency may decide to extend the time limit for the issue of the delivery order when it is necessary due to high quantities of cereals or rice accepted. However, the final date for delivery of the products shall not be later than 65 days after the deadline or entry into force referred to in the first subparagraph. In such cases the paying agency shall inform the affected operators.

2 The delivery order shall be dated and numbered and shall contain the following information:

- a the quantity to be delivered;
- b the final date for delivery of the products;
- c the storage place to which the products shall be delivered;
- d the price at which the offer or tender is accepted.

3 The delivery order shall be issued only for quantities notified to the Commission as provided for in Article 9.

Article 18

Specific provisions for the delivery of cereals and rice

1 The paying agency shall designate the storage place to which the cereals or rice shall be delivered at lowest cost.

2 Delivery to the storage place shall occur not later than 60 days following the date of issue of the delivery order. However, depending on the quantities accepted, the paying agency may extend that period by up to 14 days. In such cases the delivery period referred to in the second subparagraph of Article 17(1) may be extended accordingly. The paying agency shall inform the affected operators.

3 The operator shall bear the costs relating to the following tests carried out for cereals in accordance with the methodology referred to in Part IV of Annex I:

- (i) the amylasic activity (Hagberg) test;
- (ii) the test for the determination of the protein content of durum wheat and common wheat;
- (iii) the Zeleny test;
- (iv) the machinability test;

Status: Point in time view as at 07/02/2018.

Changes to legislation: There are currently no known outstanding effects for the Commission Implementing Regulation (EU) 2016/1240. (See end of Document for details)

- (v) analyses of contaminants.

Article 19

Transport costs for cereals and rice

1 The cost of transporting the cereals or rice from the place where the product was stored at the time of the offer or tender to the storage place specified in the delivery order shall be borne by the operator, where the distance involved is equal to or less than 50 km.

Beyond that maximum distance, the additional transport costs shall be borne by the paying agency and reimbursed by the Commission at a rate per tonne and per kilometre of EUR 0,05.

2 Where the paying agency which buys-in the cereals or rice is in a Member State other than the one in whose territory the product is stored, no account shall be taken, in calculating the maximum distance referred to in paragraph 1, of the distance between the store of the operator and the border of the Member State of the purchasing paying agency.

Article 20

Specific provisions for the delivery of beef

1 The buying-in price for beef shall be the price of the beef delivered to the entrance weighing point of the storage place or, where the meat is to be deboned, at the cutting plant.

2 The costs of unloading shall be borne by the operator.

3 Operators shall deliver the products not later than 15 days following the date of issue of the delivery order. However, depending on the quantities awarded, the paying agency may extend that period by up to seven days. In such cases the paying agency shall inform the affected operators.

Article 21

Specific provisions for the packing, delivery and storage of butter and skimmed milk powder

1 Butter shall be packed and delivered in blocks of 25 kilograms net in accordance with the requirements laid down in Part II of Annex IV.

2 Skimmed milk powder shall be packed and delivered in bags of a net weight of 25 kilograms in accordance with the requirements laid down in Part II of Annex V.

3 The operator shall deliver the butter or skimmed milk powder to the loading bay of the storage place within 21 days of the date of issue of the delivery order. However, depending on the quantities accepted, the paying agency may extend that period by up to seven days. In such cases the paying agency shall inform the affected operators.

The butter and skimmed milk powder shall be delivered on pallets of a quality suitable for long-term storage, to be exchanged against equivalent pallets. Alternatively, an equivalent system may be approved by the paying agency.

Status: Point in time view as at 07/02/2018.

*Changes to legislation: There are currently no known outstanding effects for the
Commission Implementing Regulation (EU) 2016/1240. (See end of Document for details)*

The costs incurred in unloading the butter or skimmed milk powder at the loading bay of the storage place shall be borne by the paying agency.

4 The paying agency shall require that butter and skimmed milk powder be placed and kept in storage on pallets in such a way as to create easily identifiable and readily accessible lots.

Article 22

Delivery

1 The date of delivery shall be:

- a for cereals, rice, butter and skimmed milk powder: the date on which it is confirmed that the whole of the quantity referred to in the delivery order entered the designated storage place. This date cannot be earlier than the day following the date of issue of the delivery order;
- b for each consignment of beef: the date of entrance at the weighing point of the intervention storage place or, where the meat is to be deboned, at the cutting plant.

2 The paying agency may decide that the takeover of cereals, rice, butter or skimmed milk powder takes place in the storage place where the products are held at the time the offer or tender is submitted, provided that the storage place fulfils the requirements laid down in Article 7(1) of Delegated Regulation (EU) 2016/1238 and in Article 3 of this Regulation. In that case, the date of delivery shall be the day following the date of issue of the delivery order and shall serve as the relevant date for the purposes of Article 18(2)(a) of Implementing Regulation (EU) No 908/2014.

3 The products shall be taken over by the paying agency or its representative, who shall be independent from the operator.

Section 5

Control and takeover

Article 23

The takeover record

1 The takeover record shall be issued by the paying agency after the required checks and analyses have established that the eligibility requirements laid down in Article 3 of Delegated Regulation (EU) 2016/1238 are fulfilled. It shall indicate at least:

- a the quantities delivered and, for rice, the variety;
- b the characteristics of the products as resulting from the analyses in so far as this is relevant for the calculation of the price;
- c if applicable, the quantities that have not been taken over. In this case, the operator shall be notified accordingly.

2 The takeover record shall be dated and sent to the operator and to the storekeeper.

Status: Point in time view as at 07/02/2018.

Changes to legislation: There are currently no known outstanding effects for the Commission Implementing Regulation (EU) 2016/1240. (See end of Document for details)

Article 24

Obligations of the operator

The products shall meet the eligibility requirements set out in Article 3 of Delegated Regulation (EU) 2016/1238. Where the required checks show that the products do not fulfil the eligibility requirements, the operator shall:

- (a) take back at his expense the products concerned;
- (b) pay the associated costs from the date of entry of the products into the storage place until the date of their removal from storage.

The costs to be paid by the operator shall be determined on the basis of standard amounts for entry, removal and storage costs in accordance with Article 3 of Commission Delegated Regulation (EU) No 906/2014⁽¹⁶⁾.

Article 25

Deboning requirement for beef

Where deboning is required as a condition of the tendering procedure, the paying agency shall have all the beef that is bought-in deboned in accordance with Part III of Annex III.

Section 6

Price adjustments and payments

Article 26

Price adjustments for cereals and rice

1 The price adjustment as provided for in Articles 2(2) and 3(4) of Regulation (EU) No 1370/2013 shall be made in accordance with:

- a Parts V and VI of Annex I to this Regulation in the case of cereals;
- b Part II of Annex II to this Regulation in the case of rice.

2 If the paying agency takes over and stores cereals and rice at the storage place in accordance with Article 22(2), a reduction of EUR 5/tonne shall be made to the buying-in price.

Article 27

Payments

1 Payments for the quantities stated in the takeover record shall be made no later than the 65th day following the date of delivery referred to in Article 22, unless an administrative inquiry is under way.

Status: Point in time view as at 07/02/2018.

Changes to legislation: There are currently no known outstanding effects for the Commission Implementing Regulation (EU) 2016/1240. (See end of Document for details)

2 Only the quantity actually delivered and accepted shall be paid for. However, if that quantity is greater than the quantity stated in the delivery order, only the quantity specified in the delivery order shall be paid for.

CHAPTER III

Sale of products from intervention

Article 28

Opening of the tendering procedure

1 Products taken over into public intervention and available for sale shall be sold through a tendering procedure.

2 The tendering procedure shall be opened by way of an Implementing Regulation opening the sale.

The first closing date for submission of tenders shall be fixed not earlier than six days after the publication of that Implementing Regulation in the *Official Journal of the European Union*.

3 Tendering procedures may be open for the sale of products stored in one or several regions of the Union or a Member State.

4 The Implementing Regulation opening the sale shall contain, in particular, the following information:

- a the products covered, and in particular:
 - (i) for rice, an indication of the type and variety,
 - (ii) for beef, the relevant cuts;
- b the period covered ('tendering period') and the different sub-periods during which the tenders can be submitted;
- c for beef, butter and skimmed milk powder, the minimum quantity for which a tender may be submitted;
- d the amount of the security that shall be lodged when submitting a tender.

In addition, that Implementing Regulation may contain:

- (a) the global quantities covered by the tendering procedure;
- (b) if applicable, provisions concerning transport costs for cereals and rice.

5 Tendering procedures may be restricted to specified uses or destinations and include provisions for verifying the use or destination.

Status: Point in time view as at 07/02/2018.

Changes to legislation: There are currently no known outstanding effects for the Commission Implementing Regulation (EU) 2016/1240. (See end of Document for details)

Article 29

Notice of invitation to tender and arrangements related to the invitation to tender

1 Each paying agency holding intervention stocks available for sale shall draw up a notice of invitation to tender, and publish it at least four days before the first date for the submission of tenders.

2 The notice of invitation to tender shall indicate in particular:

- a the name and address of the paying agency issuing the notice of invitation to tender;
- b the reference to the Implementing Regulation opening the sale;
- c the closing dates for the submission of tenders for each partial invitation to tender;
- d for each storage place, the name and address of the storekeeper, and, as appropriate:
 - (i) for cereals and rice, the quantities available presented in sales lots determined in such a way to ensure equal access to operators, together with a description of the quality of each sales lot;
 - (ii) for beef, the quantities available by cut, in accordance with Part IV of Annex III and the date of delivery;
 - (iii) for butter and skimmed milk powder, the quantities available and the date of delivery;
- e the delivery stage as referred to in Article 30(1)(d) and, if applicable, the type of packaging;
- f any facilities at the storage place for loading onto a means of transport;
- g for butter, where appropriate, the available quantity of sweet cream butter per storage place, as referred to in point 2(d) of Part II of Annex IV.

3 The paying agency shall ensure that notices of invitation to tender are properly publicised.

4 The paying agency shall make the necessary arrangements to enable interested parties:

- a to inspect and to take and examine samples of cereals and rice put up for sale at their own expense before submitting a tender;
- b to consult the results of the analyses referred to in Part IV of Annex I, Part I of Annex II, Part I of Annex IV or Part I of Annex V, as appropriate.

Article 30

Submission and admissibility of tenders

1 A tender shall be admissible if it complies with the requirements laid down in Article 2 and the Implementing Regulation opening the sale. It shall also meet the following conditions:

- a it indicates a reference to the Implementing Regulation opening the sale and the expiry date for the sub-period of submission of the tenders;
- b for beef, it indicates the relevant cuts;
- c for cereals and rice, it indicates the total quantity of the sales lot;
- d it indicates the price in euro tendered per unit of measurement, rounded to no more than two decimal places, exclusive of VAT, as follows:

Status: Point in time view as at 07/02/2018.

Changes to legislation: There are currently no known outstanding effects for the Commission Implementing Regulation (EU) 2016/1240. (See end of Document for details)

- (i) in the case of cereals and rice, for the product loaded onto the means of transport;
 - (ii) in the case of butter or skimmed milk powder, for the product supplied on pallets at the loading bay of the storage place or, if necessary, supplied on pallets loaded onto the means of transport where it is a lorry or railway wagon;
 - (iii) in the case of beef, for the product delivered to the loading bay of the storage place.
- e for beef, butter and skimmed milk powder, that it relates to at least the minimum quantity referred to in the Implementing Regulation opening the sale;
 - f it indicates the storage place where the product is held and, for butter and skimmed milk powder, an alternative storage place may be specified;
 - g the operator has lodged the amount of the security provided for in the Implementing Regulation opening the sale.

2 For cereals, the tendered price shall refer to the minimum quality defined in Part II of Annex I to Delegated Regulation (EU) 2016/1238 or, for rice to the standard quality defined in Section A of Annex III to Regulation (EU) No 1308/2013.

3 For beef, butter and skimmed milk powder, the tendered price shall apply to net weight.

For butter, where appropriate, the tender may specify that it is submitted exclusively for sweet cream butter as referred to in Article 29(2)(g).

Article 31

Notification of tenders to the Commission

1 Member States shall notify the Commission of all admissible tenders within the time limits set in the Implementing Regulation opening the sale.

2 The notifications provided for in paragraph 1 shall not contain the operator's name, address and VAT registration number.

3 Where a Member State does not notify the Commission of an admissible tender within the time limits referred to in paragraph 1, it shall be deemed to have notified the Commission of a nil return.

Article 32

Decisions on the selling price

1 On the basis of the tenders notified in accordance with Article 31, the Commission shall decide, in accordance with the procedure referred to in Article 229(2) of Regulation (EU) No 1308/2013:

- a not to fix a minimum selling price; or
- b to fix a minimum selling price.

For butter and skimmed milk powder the minimum selling price may vary according to the location of the products offered for sale.

Status: Point in time view as at 07/02/2018.

Changes to legislation: There are currently no known outstanding effects for the Commission Implementing Regulation (EU) 2016/1240. (See end of Document for details)

2 The decision referred to in paragraph 1 shall be published in the *Official Journal of the European Union*.

Article 33

Individual decisions on tenders

1 Where no minimum selling price has been fixed, all tenders shall be rejected.

2 Where a minimum selling price has been fixed, the paying agencies shall reject any tender lower than the minimum selling price.

The paying agencies shall only accept tenders that have been notified to the Commission in accordance with Article 31.

3 The paying agencies shall take the decisions referred to in paragraphs 1 and 2 of this Article after the publication of the decision of the Commission referred to in Article 32.

The paying agency shall notify the operators of the outcome of their participation in the tendering procedure within three working days of the entry into force of that decision of the Commission.

Article 34

Specific rules for the allocation of beef, butter and skimmed milk powder

1 For butter and skimmed milk powder, the successful operator shall be the operator offering the highest price. If the full quantity available is not allocated, the remainder shall be awarded to the other operators on the basis of the prices tendered, starting with the highest price.

2 Where acceptance of a tender would result in contracts being awarded in excess of the quantity of beef, butter or skimmed milk powder available at a particular storage place, only the quantity available shall be awarded to the operator in question. However, with the agreement of the operator, the paying agency may allocate product from other storage places to fulfil the tender quantity.

3 Where acceptance of two or more tenders offering the same price at a particular storage place would lead to contracts being awarded in excess of the available quantity of beef, butter or skimmed milk powder, the award shall be made by allocating the quantity available in proportion to the quantities tendered for. However, if such allocation leads to the award of quantities of less than the minimum quantity referred to in Article 28(4)(c), the award shall be made by drawing lots.

4 Where after the acceptance of all successful tenders the quantity of beef, butter or skimmed milk powder left at the storage place is less than the minimum quantity referred to in Article 28(4)(c), the remaining quantity shall be offered by the paying agency to the successful operators starting with the one who offered the highest price. The successful operators shall be offered the option to buy the remaining quantity at the minimum selling price.

5 The paying agency shall allocate the product on the basis of its date of entry into storage, starting with the oldest product of the total quantity available at the storage place designated by the operator or, as the case may be, the oldest of the quantity of butter or sweet cream butter or cut of beef available in the cold storage place designated by the operator.

Status: Point in time view as at 07/02/2018.

Changes to legislation: There are currently no known outstanding effects for the Commission Implementing Regulation (EU) 2016/1240. (See end of Document for details)

Article 35

Payments

Before removing the product and within the period specified in Article 37(2), operators shall pay the paying agency the amount corresponding to their tender for each quantity that they withdraw from the storage place, as notified by the paying agency in accordance with Article 33(3).

Article 36

Sales by Member States

1 In a Member State where no tendering procedure is open in accordance with Article 28, the paying agency may itself open a tendering procedure for the sale of intervention products when the total quantity remaining in all its storage places is less than:

- a for each cereal: 10 000 tonnes;
- b for rice: 2 000 tonnes;
- c for beef, butter or skimmed milk powder: 200 tonnes.

2 Chapter II of Delegated Regulation (EU) 2016/1238 and this Chapter shall apply to a tendering procedure opened by a paying agency in accordance with paragraph 1, with the exception of Articles 28(2), 29(2)(b), 30(1)(a) and (e), 31 and 32(2) of this Regulation. Article 32(1) shall apply *mutatis mutandis* to a respective decision of the Member State.

3 Within the quantities fixed in paragraph 1, paying agencies may put up for direct sale products which, after visual examination in the context of the annual stocktaking in accordance with point (g) of the first subparagraph of Article 3(3) and Article 3(4) of Delegated Regulation (EU) No 907/2014 or during the inspection after taking into intervention, may no longer be repackaged or are deteriorated.

4 The paying agencies shall ensure equality of access for all parties concerned.

Article 37

Removal order

1 On payment of the amount referred to in Article 35, the paying agency shall issue a removal order indicating:

- a the quantity in respect of which the corresponding amount has been paid;
- b the storage place in which the product is stored;
- c the final date for removal of the product.

2 The operators shall remove the product awarded to them within 30 days of the notification referred to in Article 33(3). After that period of time the costs and risks shall be borne by the operator.

Status: Point in time view as at 07/02/2018.

Changes to legislation: There are currently no known outstanding effects for the Commission Implementing Regulation (EU) 2016/1240. (See end of Document for details)

Article 38

Removal of butter and skimmed milk powder

- 1 At the time of removal from the storage place and in the case of delivery outside the storage place, the paying agency shall make the butter and skimmed milk powder available on pallets at the loading bay of the storage place, and loaded onto the means of transport where it is a lorry or a railway wagon. The costs involved shall be borne by the paying agency.
- 2 The operator shall return equivalent quality pallets to the paying agency on removal from the storage place. Alternatively, an equivalent arrangement may be agreed with the paying agency.
- 3 Any stowage and depalletising costs shall be borne by the operator of the butter or skimmed milk powder.

[^{F2}CHAPTER IV

Disposal of products from intervention for the scheme for food distribution to the most deprived in the Union

Article 38a

Making products from intervention available for the scheme

- 1 The Commission may, by way of an Implementing Regulation adopted in accordance with the procedure referred to in Article 229(2) of Regulation (EU) No 1308/2013, make intervention products available for the scheme for food distribution to the most deprived in the Union referred to in Article 16(2) of that Regulation ('the scheme').
- 2 The Implementing Regulation referred to in paragraph 1 shall contain, in particular, the following information:
 - a the type and quantity of the products that are made available for the scheme;
 - b the location of the products made available for the scheme and the criteria for the distribution of the available lots among the Member States concerned on the basis of their location;
 - c the way in which the products are to be disposed of in accordance with the second subparagraph of Article 23(4) of Regulation (EU) No 223/2014 of the European Parliament and of the Council^(d7) (direct use, processing or sale) in order to make them available for the scheme in a way that is economically the most favourable option taking into account the nature and characteristics of the products;
 - d where the products are to be sold in accordance with Article 38b of this Regulation, the level of the security to be lodged in accordance with Article 4(a) of Delegated Regulation (EU) 2016/1238 and the price below which the products shall not be sold.
- 3 Member States interested to be allocated part or all of the quantity referred to in point (a) of paragraph 2 shall submit a request to the Commission within 10 working days after the publication of the Implementing Regulation referred to in paragraph 1. That request shall specify the type and the quantity (expressed in tonnes) of the product requested. The quantity requested by a Member State shall not exceed the quantity referred to in point (a) of paragraph 2.

Status: Point in time view as at 07/02/2018.

Changes to legislation: There are currently no known outstanding effects for the Commission Implementing Regulation (EU) 2016/1240. (See end of Document for details)

- 4 Within 20 working days after the publication of the Implementing Regulation referred to in paragraph 1, the Commission shall adopt an Implementing Regulation without applying the procedure referred to in Article 229(2) or (3) of Regulation (EU) No 1308/2013 by which it:
- a allocates a quantity to each Member State that submitted a request;
 - b specifies the location of the available lots as distributed to the Member States concerned in accordance with the criteria referred to in point (b) of paragraph 2.

For the purposes of point (a) of the first subparagraph, where the total quantity requested by Member States exceeds the quantity referred to in point (a) of paragraph 2, a quantity shall be allocated to the Member States concerned in proportion to the quantity requested by them.

- 5 Where the quantity allocated to a Member State is 50 % lower than the quantity requested, the Member State may renounce the quantity allocated to it by informing the Commission of its decision within 10 working days after the publication of the Implementing Regulation by which the products were allocated. Those products shall no longer be available for the scheme under that specific Implementing Regulation.

Article 38b

Sale of intervention products made available for the scheme

- 1 Where the Implementing Regulation referred to in Article 38a(1) provides that the products made available for the scheme have to be disposed of by sale, paragraphs 2 to 7 of this Article shall apply.

- 2 The paying agency of the Member State that has been allocated products in accordance with Article 38a(4) shall, within 40 working days after the publication of the Implementing Regulation by which the products were allocated, open a tendering procedure for the sale of the products.

Where a Member State has been allocated products held by the paying agency of another Member State, the paying agency holding the products shall provide to the paying agency selling the products the information referred to in Article 29(2)(d) to (g) within 10 working days after the publication of the Implementing Regulation by which the products were allocated.

- 3 Where the paying agency of a Member State that has been allocated products held by the paying agency of another Member State sells all or part of those products, the paying agency selling the products shall pay the paying agency holding them at the accounting value referred to in Article 16(2) of Regulation (EU) No 1308/2013. That payment shall be made within 4 working days after the receipt of the payment from an operator of the amount corresponding to his tender. The paying agency holding the products shall issue the removal order referred to in Article 37 of this Regulation within 5 working days after the receipt of the payment from the paying agency selling the products.

- 4 The paying agency selling the products shall, within 10 working days after the receipt of the payment from an operator of the amount corresponding to his tender, transfer the difference between the selling price and the accounting value of the products, multiplied by the quantity sold, to the body to which payments are made by the Commission under Regulation (EU) No 223/2014. That transferred amount shall be used to finance the purchase and distribution of food for the most deprived in addition to the resources already available in the operational programme.

Status: Point in time view as at 07/02/2018.

Changes to legislation: There are currently no known outstanding effects for the Commission Implementing Regulation (EU) 2016/1240. (See end of Document for details)

5 Any administrative costs related to the sale of the products shall be borne by the paying agency selling the products.

6 Chapter II of Delegated Regulation (EU) 2016/1238 and Chapter III of Title II of this Regulation, with the exception of Article 28(2), Article 29(2)(b), Article 30(1)(a) and (e), Article 31, 32(2), the second subparagraph of Article 33(2) and Article 36 of this Regulation, shall apply to a tendering procedure opened by a paying agency in accordance with paragraph 2 of this Article. Articles 32(1) and 33(3) shall apply *mutatis mutandis* to a respective decision of a Member State. For the purposes of Article 30(1)(g), the amount of the security provided for in the Implementing Regulation opening the sale shall be understood as the amount of the security provided for in the Implementing Regulation referred to in Article 38a(1).

7 Where all or part of the products allocated to a Member State have not been sold within 5 months after the publication of the Implementing Regulation by which the products were allocated, those products shall no longer be available under that specific Implementing Regulation.]

Textual Amendments

- F2** Inserted by [Commission Implementing Regulation \(EU\) 2017/1479 of 16 August 2017 amending Implementing Regulation \(EU\) 2016/1240 as regards the disposal of intervention stocks for the scheme for food distribution to the most deprived.](#)

TITLE III

AID FOR PRIVATE STORAGE

CHAPTER I

Specific rules for aid for private storage

Section I

General provisions

Article 39

Opening of tendering procedures and fixing aid in advance

1 The Implementing Regulation opening the tendering procedure or fixing the amount of aid in advance may contain the following information:

- a the products, or types of products, covered with their relevant CN codes, if applicable;
- b in the case of aid fixed in advance, the amount of aid for storage per unit of measurement for the products covered;
- c the unit of measurement of the quantities;
- d if the tender or aid fixed in advance relates to products that have already been placed in storage;

Status: Point in time view as at 07/02/2018.

*Changes to legislation: There are currently no known outstanding effects for the
 Commission Implementing Regulation (EU) 2016/1240. (See end of Document for details)*

- e in the case of tenders, the period covered ('tendering period') and, if necessary, the different sub-periods during which tenders can be submitted, and in the case of aid fixed in advance the period for submitting an application;
- f the period of storage;
- g the global quantity, if applicable;
- h the minimum quantity per tender or application;
- i the amount of the security per unit of measurement in the case of tenders and, where applicable, for applications;
- j the periods of placing into store and of removal from store;
- k the specifications that have to appear on the packaging, if applicable.

2 Where the granting of aid for private storage is restricted to certain Member States or regions of a Member State as referred to in Article 18(2)(b) of Regulation (EU) No 1308/2013, tenders and applications may be lodged only in the Member State(s) concerned.

3 In the case of tenders, at least six days shall elapse between the entry into force of the Implementing Regulation opening the tendering procedure and the first date for the submission of tenders.

Article 40

Submission and admissibility of tenders and applications for aid for private storage

A tender or application for aid for private storage shall be admissible if it complies with the requirements laid down in Article 2 and the following conditions are met:

- (a) it includes at least the following information:
 - (i) a reference to the Implementing Regulation opening the tendering procedure or fixing the amount of aid for private storage in advance;
 - (ii) the storage period where so required in the Implementing Regulation opening the tendering procedure or fixing the amount of aid for private storage in advance;
 - (iii) the quantity of products covered by the tender or application;
 - (iv) where products are already stored, the name and address of each place of private storage, the location of the storage lots/batches/vats/silos with the corresponding quantities and, where appropriate, the number identifying the approved undertaking;
 - (v) in the case of tenders, the expiry date for the sub-period of submission;
 - (vi) in the case of tenders, the amount of aid in euro proposed per unit of measurement rounded to no more than two decimal places, exclusive of VAT;
- (b) the operator has lodged the amount of the security referred to in the Implementing Regulation opening the tendering procedure or fixing the amount of aid for private storage in advance.

Status: Point in time view as at 07/02/2018.

Changes to legislation: There are currently no known outstanding effects for the Commission Implementing Regulation (EU) 2016/1240. (See end of Document for details)

Article 41

Verification of tenders and applications by the paying agency

1 The paying agency shall decide on the admissibility of tenders and applications on the basis of the conditions set out in Articles 2 and 40.

2 Where the paying agency decides that a tender or application is inadmissible, it shall inform the operator concerned within three working days of the receipt of the tender or application.

Article 42

Notification of tenders and applications to the Commission

1 Member States shall notify the Commission of all admissible tenders and applications within the following time limits:

- a in the case of tenders, the time limits laid down in the Implementing Regulation opening the tendering procedure shall apply;
- b in the case of applications, notifications shall be submitted not later than 12.00 (Brussels time) each Tuesday and shall relate to the quantities of the products which, during the preceding week, have been the subject of an admissible application, and of the related information. The Commission can request that such notifications are made more frequently where such information is necessary for the purposes of managing the scheme.

2 The notifications provided for in points (a) and (b) of paragraph 1 shall not contain the operators' name, address and VAT registration number.

3 Where a Member State does not notify the Commission of an admissible tender or application within the time limits referred to in points (a) and (b) of paragraph 1, it shall be deemed to have notified the Commission of a nil return.

Section II

Fixing the amount of aid for private storage via a tendering procedure

Article 43

Decisions on the maximum amount of aid for private storage

1 On the basis of the tenders notified in accordance with Article 42, the Commission shall decide, as provided for in Article 4(2)(a) of Regulation (EU) No 1370/2013:

- a not to fix a maximum amount of the aid; or
- b to fix a maximum amount of the aid.

2 Where the tender is subject to a global quantity as referred to in Article 39(1)(g), and if the award of the total quantities for which that amount has been offered would lead to the global quantity being exceeded, the Commission shall, in accordance with the procedure referred to in Article 229(2) of Regulation (EU) No 1308/2013, adopt a decision fixing an

Status: Point in time view as at 07/02/2018.

Changes to legislation: There are currently no known outstanding effects for the Commission Implementing Regulation (EU) 2016/1240. (See end of Document for details)

allocation coefficient. The coefficient shall apply to the tenders which have been received at the level of the maximum amount of aid.

By way of derogation from Article 2(6), an operator to whom an allocation coefficient applies may withdraw his tender within 10 working days of the date of entry into force of the decision fixing the allocation coefficient.

3 Decisions on aid referred to in paragraphs 1 and 2 shall be published in the *Official Journal of the European Union*.

Article 44

Individual decisions on tenders

1 Where no maximum amount of aid for private storage has been fixed, all tenders shall be rejected.

2 Where a maximum amount of aid has been fixed, the paying agency shall accept tenders which are equal to, or lower than that amount, without prejudice to Article 43(2). All the other tenders shall be rejected.

The paying agency shall only accept tenders that have been notified in accordance with Article 42.

3 The paying agency shall take the decisions referred to in paragraphs 1 and 2 of this Article after the publication of the decision of the Commission referred to in Article 43(1).

The paying agency shall notify operators of the outcome of their participation in the tendering procedure within three working days of the entry into force of that decision of the Commission.

Section III

Fixing the amount of aid for private storage in advance

Article 45

Decisions on applications for aid for private storage fixed in advance

1 For products already in storage, an admissible application shall be deemed to have been accepted on the eighth working day following the date of receipt of that application, provided that the Commission does not adopt a decision in accordance with paragraph 3 in the interim.

2 For products that are not already stored, decisions on acceptance of an admissible application shall be notified by the paying agency to the operator on the eighth working day following the date of receipt of that application, provided that the Commission does not adopt a decision in accordance with paragraph 3 in the interim.

3 Where an examination of the situation reveals that excessive use has been made of the aid for private storage scheme, or that there is a risk of excessive use or speculation, the Commission may, without applying the procedure referred to in Article 229(2) or (3) of Regulation (EU) No 1308/2013, decide to:

Status: Point in time view as at 07/02/2018.

Changes to legislation: There are currently no known outstanding effects for the Commission Implementing Regulation (EU) 2016/1240. (See end of Document for details)

- a suspend the application of the scheme for not more than five working days; applications submitted during that period shall not be accepted;
- b set a single percentage by which the quantities in the applications are reduced, subject to observance of the minimum contractual quantity where appropriate;
- c reject applications made before the period of suspension the acceptance of which would have been decided during the period of suspension.

By way of derogation from Article 2(6), an operator to whom point (b) of the first subparagraph applies may withdraw his application within 10 working days of the date of entry into force of the decision setting the percentage reduction.

Section IV

Placing of products into private storage

Article 46

Information related to the place of private storage for products not yet in storage

Following receipt of the notification referred to in the second subparagraph of Article 44(3) or the notification of the decision referred to in Article 45(2), the operator shall notify the paying agency of the timeframe for the entry of products into storage, the name and address of each place of private storage and the corresponding quantities. The notification shall be provided to the paying agency at least five working days before the start of the placing lots into storage. The paying agency may decide to accept a shorter period than five working days.

Article 47

Placing into storage of products not yet in storage

1 Products shall be placed into storage within 28 days following the notification referred to in the second paragraph of Article 44(3) in the case of tenders, or the notification of the decision referred to in Article 45(2) in the case of applications.

2 For meat, placing in storage shall begin, for each individual lot of the quantity covered by the tender or application, on the day on which it comes under the control of the competent authority. That day shall be the day on which the net weight of the fresh **or** chilled product is determined:

- a at the place of private storage, where the product is frozen on the premises;
- b at the place of freezing, where the product is frozen in suitable facilities outside the place of private storage.

3 Placing into storage shall be considered completed on the day on which the last individual lot of the quantity covered by the tender or application is placed in storage.

Status: Point in time view as at 07/02/2018.

*Changes to legislation: There are currently no known outstanding effects for the
Commission Implementing Regulation (EU) 2016/1240. (See end of Document for details)*

CHAPTER II

Storage contracts

Section I

Conclusion of contracts

Article 48

Contractual storage period

- 1 The contractual storage period starts on the day following:
 - a the date of the notification referred to in Article 44(3), or the date of receipt of an admissible application without prejudice to Article 45(1), for products already placed in storage;
 - b the date that placing into storage is considered completed in accordance with Article 47(3) for products which are not yet stored.
- 2 The last day of the contractual storage period may be fixed in the Implementing Regulation opening the tendering procedure or fixing the amount of aid for private storage in advance, as referred to in Article 39(1)(f).

By way of derogation from Article 3(4) of Council Regulation (EEC, Euratom) No 1182/71⁽¹⁸⁾, when the last day of the contractual storage period falls on Saturday, Sunday or a public holiday, the contractual storage period shall end with the expiry of the last hour of that day.

Article 49

Conclusion of contracts

Contracts shall be concluded between the paying agency of the Member State in the territory of which the products are stored or will be stored and operators fulfilling the requirements laid down in Article 2 of Delegated Regulation (EU) 2016/1238 from whom a tender or application has been accepted.

Contracts shall be concluded for the quantity actually placed in storage (the 'contractual quantity'), which shall not exceed the quantity referred to the second paragraph of Article 44(3) in the case of tenders, or the quantity in the application in respect of products already in store, or the notification of the decision referred to in Article 45(2) in the case of applications for products not yet in store.

Where the quantity actually placed in storage is less than 95 % of the quantity in the tender or application, or the quantity arising from the application of Article 45(3)(b), no contract shall be concluded.

Contracts shall not be concluded where the eligibility of the products is not confirmed.

Status: Point in time view as at 07/02/2018.

Changes to legislation: There are currently no known outstanding effects for the Commission Implementing Regulation (EU) 2016/1240. (See end of Document for details)

Article 50

Notification of conclusion of contracts

The paying agency shall notify the successful operator of a contract considered as being concluded within five working days of the date of issue of the control report referred to in Article 61(1), subject to receiving all of the documents necessary for concluding the contract.

The date of conclusion of the contract shall be that on which the paying agency notifies the operator.

Section II

Elements of the contract and obligations of the operator

Article 51

Elements of the contract

The contract shall be construed as including, where appropriate, the elements provided for in Article 52, as well as those provided for in:

- (a) the relevant provisions of the Implementing Regulation opening the tendering procedure and in the tender; or
- (b) the relevant provisions of the Implementing Regulation fixing the amount of aid for private storage in advance and in the application.

Article 52

Obligations of the operator

- 1 Contracts shall cover at least the following obligations for the operator:
 - a to place and to keep the contractual quantity in storage, during the contractual storage period, at their own risk and expense under conditions ensuring the maintenance of the characteristics of the products referred to in Article 3 of Delegated Regulation (EU) 2016/1238, without:
 - (i) substituting the stored products, except in the case of sugar in accordance with paragraph 3;
 - (ii) or transferring them to another place of private storage or, in the case of sugar, to another silo;
 - b to retain the weighing-in documents established at the time of entry into the place of private storage;
 - c to send the documents relating to the operations of placing in storage, including the location of the storage lots/batches/vats/silos with the corresponding quantities, to the paying agency not later than five working days after the date of placing into storage referred to in Article 47(3);

Status: Point in time view as at 07/02/2018.

Changes to legislation: There are currently no known outstanding effects for the Commission Implementing Regulation (EU) 2016/1240. (See end of Document for details)

- d to allow the paying agency to check at any time that all the obligations laid down in the contract are being adhered to;
- e to make the products stored easily accessible and individually identifiable by storage lot/batch/vat/silo.

2 By way of derogation from point (a)(ii) of paragraph 1, the paying agency may authorise a relocation of the stored products under the following conditions:

- (i) for cheeses benefiting from a protected designation of origin (PDO) or from a protected geographical indication (PGI), where the operator submits a reasoned request;
- (ii) for other products, in exceptional cases, where the operator submits a reasoned request.

3 By way of derogation from point (e) of paragraph 1 of this Article, sugar subject to a contract may be stored in a silo designated by the operator with other sugar provided that the contractual quantity is kept in storage in the designated silo during the contractual period in accordance with Article 8(1) of Delegated Regulation (EU) 2016/1238.

4 The operator shall, on request, make available to the paying agency responsible for checking all documentation, for each contract, allowing in particular the following information on the products placed in storage to be verified:

- a the number identifying the approved undertaking and, if necessary, the Member State of production;
- b the origin and the date of production of the products, or for sugar the marketing year of production, and for meat the day of slaughtering;
- c the date of placing into storage;
- d the weight and, in the case of meat, the number of cuts packaged;
- e the address of the place of private storage and the means allowing for ready identification of the product within the place of private storage or, for bulk sugar, the identification of the silo designated by the operator;
- f the end date of the contractual storage period and the actual date of removal from contractual storage.

5 The operator or, where applicable, the storekeeper shall keep a register at the warehouse covering, by contract number:

- a the identification of the products placed in storage by lot/batch/vat/silo;
- b the dates of placing in and removal from storage;
- c the quantity of products in storage by lot/batch/vat/silo;
- d the location of the products by storage lot/batch/vat/silo within the store.

Status: Point in time view as at 07/02/2018.

Changes to legislation: There are currently no known outstanding effects for the Commission Implementing Regulation (EU) 2016/1240. (See end of Document for details)

CHAPTER III

Removal of products and payment of aid for private storage

Section I

Removal of products from storage

Article 53

Removal from storage

1 Removal from storage may start on the day following the last day of the contractual storage period or, as the case may be, from the date specified in the Implementing Regulation opening the tendering procedure or fixing the amount of aid for private storage in advance.

2 Removal from storage shall be in whole storage lots unless the paying agency authorises removal in smaller quantities.

However, in the case of sealed products as referred to in Article 60, only a sealed quantity may be removed from store.

3 Where in the Implementing Regulation opening the tendering procedure or fixing the amount of aid for private storage in advance, the contractual storage period is specified as being between a period of days, the operator shall notify the paying agency of the intention to begin removing products from storage, indicating the storage lots/batches/vats/silos involved, at least five working days before the start of removal operations.

The paying agency may decide to accept a shorter period than five working days.

Section II

Payment

Article 54

Application for payment of aid for private storage

The operator shall lodge an application for payment within three months of the end of the contractual storage period.

Article 55

Payment of aid for private storage

Payment of the aid shall be made not later than 120 days following the date on which an application for payment is lodged provided that the obligations of the contract have been met.

However, if an administrative inquiry is under way, payment shall not be made until entitlement has been recognised.

Status: Point in time view as at 07/02/2018.

Changes to legislation: There are currently no known outstanding effects for the Commission Implementing Regulation (EU) 2016/1240. (See end of Document for details)

TITLE IV

CHECKS AND PENALTIES

CHAPTER I

Checks

Article 56

General provisions on checks relating to public intervention and aid for private storage

1 Paying agencies shall take all necessary measures to ensure compliance with the requirements relating to public intervention and the granting of aid for private storage laid down in Delegated Regulation (EU) 2016/1238, this Regulation and the Implementing Regulations referred to in Article 1(2)(a) and (b) of this Regulation.

The measures shall include full administrative checking of offers and tenders for public intervention and tenders and applications for aid for private storage, which shall be supplemented by on-the-spot documentary and physical checks as specified in this Title.

2 The verification of the weight of products delivered to public intervention and, in the case of aid for private storage, of the contractual quantity shall be conducted in the presence of the officials of the paying agency.

3 Physical samples taken for the purposes of verifying the quality and composition of products for public intervention and aid for private storage shall be taken by the officials of the paying agency or in their presence.

4 For the purposes of the audit trail, all stock and financial records and documents checked by the paying agency shall be stamped or initialled during the control visit. Where computer records are verified, a record of the check undertaken shall be included in the inspection file, either in paper or in electronic form. Such records shall be made available to the Commission on request.

Article 57

Specific provisions on checks relating to public intervention

1 Without prejudice to the checks required by this Regulation for the takeover of products, the checks of the intervention stocks shall be carried out in accordance with Article 3 of Delegated Regulation (EU) No 907/2014.

2 Where the storage place referred to in Article 7(1)(a)(ii) is in a Member State other than that where the offer or tender is submitted, the paying agency that received the offer or tender may request assistance from the paying agency responsible for that storage place, including an on-site check. The assistance shall be provided within the period requested by the paying agency that received the offer or tender.

3 For beef, the checks shall be carried out in accordance with Parts I and III of Annex III.

Status: Point in time view as at 07/02/2018.

Changes to legislation: There are currently no known outstanding effects for the Commission Implementing Regulation (EU) 2016/1240. (See end of Document for details)

Article 58

Specific provisions on checks relating to public intervention for cereals and rice

1 Notwithstanding Article 56(2), the quantity delivered shall be weighed in the presence of the operator and a representative of the paying agency who is independent from the operator.

However, if the representative of the paying agency is also the storekeeper, the paying agency shall, within 30 days of the date of delivery, conduct an inspection involving at least a volumetric check. Any difference between the quantity determined by weighing and the quantity estimated in accordance with the volumetric method shall not exceed 5 %.

Where the 5 % tolerance is not exceeded, the storekeeper shall bear all costs relating to any difference observed, at a later weight check, from the weight entered in the accounts on takeover.

Where the 5 % tolerance is exceeded, the cereals or rice shall be weighed forthwith. Where the weight determined is less than that recorded, the costs of weighing shall be borne by the storekeeper. Otherwise, the costs of weighing shall be borne by the paying agency.

2 Where the level of contaminants in cereals is to be checked on the basis of the risk analysis referred to in point 3 of Part I of Annex I to Delegated Regulation (EU) 2016/1238, the paying agency shall be liable for the financial consequences of any failure to comply with the maximum contaminant levels in accordance with the rules set out in Article 3(6) of Delegated Regulation (EU) No 907/2014.

However, in the case of ochratoxin A and aflatoxin, if the paying agency concerned is able to prove to the Commission's satisfaction that the standards were met on entry, that normal storage conditions were observed and that the storekeeper's other commitments were respected, the financial liability shall be borne by the Union budget.

Article 59

Specific provisions for the takeover in storage place of the storekeeper for cereals and rice

1 If the takeover of cereals or rice takes place at the storage place where the products are held at the time the offer or tender is submitted, the quantity taken over shall be established on the basis of the store register, which shall fulfil professional standards which allow to guarantee compliance with Union legislation, in particular with Annex III to Delegated Regulation (EU) No 907/2014, and provided that:

- a the store register shows:
 - (i) the weight recorded on weighing carried out within a period of no more than 10 months before the takeover;
 - (ii) the physical quality characteristics at the time of weighing and, in particular, the moisture content;
 - (iii) trans-silages, if any, and treatments carried out;

Status: Point in time view as at 07/02/2018.

Changes to legislation: There are currently no known outstanding effects for the Commission Implementing Regulation (EU) 2016/1240. (See end of Document for details)

- b the storekeeper declares that the lot offered corresponds in all respects to the details contained in the store register;
- c the quality characteristics established at the time of weighing are the same as those of the representative sample made up from the samples taken by the paying agency or its representative at a rate of one for every 60 tonnes.

2 If paragraph 1 applies, the weight to be recorded in the store register and financial accounts provided for in point (a) of the first subparagraph of Article 3(3) of Delegated Regulation (EU) No 907/2014 shall be that entered in the store register and adjusted, where appropriate, to take account of any difference between the moisture content or the percentage of miscellaneous impurities (Schwarzbesatz) recorded at the moment of weighing and those determined on the basis of the representative sample. A difference between the percentages of miscellaneous impurities may only be taken into account to reduce the weight entered in the store register.

Within 30 days of takeover the paying agency shall make a volumetric check. Any difference between the quantity determined by weighing and the quantity estimated in accordance with the volumetric method shall not exceed 5 %.

Where the 5 % tolerance is not exceeded, the storekeeper shall bear all costs relating to any difference observed, at a later weight check, from the weight entered in the accounts on takeover.

Where the 5 % tolerance is exceeded, the cereals or rice shall be weighed forthwith. Where the weight determined is less than that recorded, account being taken of the tolerance limits provided for in point 1 of Annex IV to Delegated Regulation (EU) No 907/2014, the costs of weighing shall be borne by the storekeeper. Otherwise, the costs of weighing shall be borne by the European Agricultural Guarantee Fund.

Article 60

Specific provisions on checks relating to aid for private storage

1 For all the lots put into storage, the paying agency shall undertake on-the-spot documentary checks within 30 days of the start of the contractual storage period referred to in Article 48(1) in order to verify the contractual quantity referred to in Article 49. Such checks shall include an examination of the store register referred to in Article 52(5) and of supporting documents, such as weigh tickets and delivery docketts, as well as physical verification of the presence of the lots and the identity of the products in the place of private storage.

In the case of meat, the checks shall take place at the time of placing into private storage, and for olive oil, prior to the official sealing of the vats.

In duly justified circumstances, the paying agency may extend the period referred to in the first subparagraph by up to 15 days. In such cases, the paying agency shall inform the affected operators.

2 In addition to the checks required under paragraph 1, a representative statistical sample of at least 5 % of the lots covering at least 5 % of the total quantities placed in storage shall be physically checked to ensure that the quantity, nature and composition, packaging and marking of the products and storage lots conform to the requirements for private storage and to the particulars specified by the operator in their tender or application.

In the case of cheese, physical checks shall be undertaken on all lots in order to verify the contractual quantity.

Status: Point in time view as at 07/02/2018.

Changes to legislation: There are currently no known outstanding effects for the Commission Implementing Regulation (EU) 2016/1240. (See end of Document for details)

3 During the storage period, the paying agency shall also undertake unannounced on-the-spot checks to ensure the presence and identity of the contractual quantity in the place of private storage, and that sugar stored in bulk is present in the silo designated by the operator. The check shall be undertaken on the basis of a random statistical sample of at least 5 % of the lots covering at least 5 % of the total quantities for which contracts have been concluded. This sample shall not include more than 25 % of lots already checked in accordance with paragraph 2, unless it would not be possible to conduct the on-the-spot check of at least 5 % of the lots covering at least 5 % of the total quantities for which contracts have been concluded.

The unannounced check referred in the first subparagraph shall not be necessary where the paying agency, with the agreement of the operator, has sealed the products in such a way that the contractual quantities cannot be removed from the place of storage without breaking seal.

4 At the end of the contractual storage period, or before the start of the removal of products where Article 53(3) applies, the paying agency shall undertake on-the-spot checks to verify that the contractual commitment has been met based on a documentary check of the store register and supporting documents, as well as a verification of the presence of the lots and the identity of the products in the place of private storage.

In addition to the checks referred to in the first subparagraph, a representative statistical sample of at least 5 % of the lots covering at least 5 % of the total quantities for which contracts have been concluded shall be physically checked to verify the quantity, type, packaging and marking and identity of the products in the place of private storage.

5 Where the paying agency, with the agreement of the operator, has sealed the products in such a way that the stored quantity cannot be removed from the individual lot without breaking seal, the checks referred to in paragraphs 3 and 4 may be limited to verifying the presence and integrity of the seals.

F³ Article 60a

Specific provision on checks relating to public intervention and aid for private storage for milk and milk products

1 The eligibility of butter, skimmed milk powder and cheese to receive aid for private storage shall be established in accordance with the methods laid down in Annexes VI, VII and VIII respectively.

Those methods shall be established by reference to the latest versions of the relevant European or international standards, as the case may be, in force at least 6 months before the first day of the public intervention period as defined in Article 12 of Regulation (EU) No 1308/2013.

2 The results of the checks conducted by applying the methods set out in this Regulation shall be evaluated in accordance with Annex IX.]

Textual Amendments

- F3** Inserted by [Commission Implementing Regulation \(EU\) 2018/150 of 30 January 2018 amending Implementing Regulation \(EU\) 2016/1240 as regards methods for the analysis and quality evaluation of milk and milk products eligible for public intervention and aid for private storage.](#)

Status: Point in time view as at 07/02/2018.

Changes to legislation: There are currently no known outstanding effects for the Commission Implementing Regulation (EU) 2016/1240. (See end of Document for details)

Article 61

Reporting of checks

1 The paying agency shall draw up a control report within five working days of the completion of each on-the-spot check undertaken and, if appropriate, of the checks referred to in Article 56(3). The report shall describe precisely the different items checked and shall set out:

- a the date and time of commencement of the check;
- b details of any advance notice given;
- c the duration of the check;
- d the responsible persons present;
- e the nature and extent of the checks carried out, providing, in particular, details of the documents and products examined;
- f the findings and conclusions;
- g whether any follow-up is required.

The report shall be signed by the responsible paying agency official and either countersigned by the operator or, where applicable, by the storekeeper, or sent to the operator by registrable means. The report shall be included in the payment file.

2 In case of non-compliance of products subject to the check, the verification shall be extended to a larger statistical sample to be determined by the paying agency.

3 The paying agency shall record any cases of non-compliance on the basis of the criteria of gravity, extent, duration and repetition that may result in exclusion in accordance with Article 62(1), or in the repayment of unduly paid, aid for private storage, including interest where applicable, in accordance with Article 62(4).

CHAPTER II

Penalties and administrative measures

Article 62

Penalties and administrative measures in relation to aid for private storage

1 Where the paying agency finds that a document presented by an operator, which is required under Delegated Regulation (EU) 2016/1238, this Regulation or an Implementing Regulation referred to in Article 1(2)(b) of this Regulation, provides incorrect information, and where the incorrect information concerned is decisive for the granting of aid for private storage, the paying agency shall exclude the operator from the procedure of granting aid for the product for which the incorrect information has been given for a period of one year from the date of adoption of a final administrative decision establishing the irregularity.

2 The exclusion provided for in paragraph 1 shall not apply if the operator proves, to the satisfaction of the paying agency, that the situation referred to in that paragraph is due to force majeure or obvious error.

Status: Point in time view as at 07/02/2018.

Changes to legislation: There are currently no known outstanding effects for the Commission Implementing Regulation (EU) 2016/1240. (See end of Document for details)

3 Unduly paid aid shall be recovered, with interest, from the operators concerned. The rules laid down in Article 27 of Implementing Regulation (EU) No 908/2014 shall apply *mutatis mutandis*.

4 Implementation of administrative penalties and recovery of unduly paid amounts, as provided for in this Article, are without prejudice to communication of irregularities to the Commission pursuant to Commission Regulation (EC) No 1848/2006⁽¹⁹⁾.

TITLE V

NOTIFICATIONS AND FINAL PROVISIONS

CHAPTER I

Notifications

Section I

General provisions on notifications

Article 63

Method of notification

The notifications referred to in this Regulation, as well as in Implementing Regulations referred to in Article 1, shall be made in accordance with Commission Regulation (EC) No 792/2009⁽²⁰⁾.

Article 64

Notifications concerning paying agencies

1 Member States shall notify the Commission of the approved paying agencies responsible for intervention buying-in and sales and for aid for private storage.

2 The Commission shall make available to the Member States and to the public the list of approved paying agencies, including by way of publication on the internet.

Section II

Notifications as regards public intervention

Article 65

Notifications of information on intervention stocks

1 Member States whose paying agencies hold intervention stocks shall notify the Commission, not later than the 15th of each month, of the following items:

Status: Point in time view as at 07/02/2018.

Changes to legislation: There are currently no known outstanding effects for the Commission Implementing Regulation (EU) 2016/1240. (See end of Document for details)

- a for cereals and rice:
 - (i) the quantities stored from the beginning of the marketing year;
 - (ii) the cumulative quantities taken over since the beginning of the marketing year;
 - (iii) the cumulative quantities which have left the storage places since the beginning of the marketing year, identified where appropriate by type of use or destination, and the cumulative quantities lost;
 - (iv) the cumulative quantities committed, identified where appropriate by type of use or destination;
 - (v) the quantities under offer at the end of the monthly reporting period;
- b for butter and skimmed-milk powder:
 - (i) the quantities for each product in storage at the end of the previous month and the quantities entering and leaving the storage places during that month;
 - (ii) a breakdown of the quantities of each product leaving the storage places during the previous month, according to the Regulation opening the tendering procedure for the sale of the products concerned;
 - (iii) a breakdown by age of the quantities in storage at the end of the previous month;
- c for beef:
 - (i) the quantities for each product in storage at the end of the previous month and the quantities entering and leaving the storage places during that month;
 - (ii) a breakdown of the quantities of each product leaving the storage places during the previous month, according to the Regulation opening the tendering procedure for the sale of the products concerned;
 - (iii) the quantities of each cut covered by contracts of sale concluded in the previous month;
 - (iv) the quantities of each cut covered by removal orders issued in the previous month;
 - (v) the quantities of each cut bought in during the previous month;
 - (vi) the uncommitted stocks and the physical stocks of each cut at the end of the previous month, with details of the length of time the uncommitted stocks have been in storage;
- d for all products:
 - (i) the opening of a tendering procedure, the quantities awarded and the minimum sale prices fixed in the case of application of Article 36;
 - (ii) [F4: information relating to disposals for the scheme for food distribution to the most deprived, including the amount concerned (the difference between the selling price and the accounting value) and the moment at which that amount is transferred to the body to which payments are made by the Commission under Regulation (EU) No 223/2014 in accordance with Article 38b(4) of this Regulation.]

Status: Point in time view as at 07/02/2018.

Changes to legislation: There are currently no known outstanding effects for the Commission Implementing Regulation (EU) 2016/1240. (See end of Document for details)

2 The Commission may request that notifications provided for in paragraph 1 be made with an increased frequency where that is necessary for the purposes of the efficient management of the intervention system.

3 For the purposes of point (b) of paragraph 1:

- a 'quantities entering' means quantities physically placed in storage, whether or not taken over by the paying agency;
- b 'quantities leaving' means quantities which have been removed or, if taken over by the purchaser before removal, quantities taken over.

4 For the purposes of point (c) of paragraph 1:

- a 'uncommitted stocks' means stocks not yet covered by a contract of sale;
- b 'physical stocks' means uncommitted stocks plus stocks covered by a contract of sale but not yet taken over.

Textual Amendments

- F4** Substituted by [Commission Implementing Regulation \(EU\) 2017/1479 of 16 August 2017 amending Implementing Regulation \(EU\) 2016/1240 as regards the disposal of intervention stocks for the scheme for food distribution to the most deprived.](#)

Section III

Notifications as regards aid for private storage

Article 66

Notification of information on private storage

Member States in which the aid for private storage scheme is used shall notify the Commission:

- (a) at least once a week of the products and quantities for which contracts have been concluded during the preceding week, broken down by storage period;
- (b) not later than the 15th of each month for the previous month:
 - (i) of the quantities of products placed into and leaving private storage during the month concerned, where applicable broken down by categories;
 - (ii) of the quantities of products in private storage at the end of the month concerned, where applicable broken down by categories;
 - (iii) of the quantities of products in respect of which the contractual storage period has ended;
 - (iv) if the storage period has been curtailed or extended, as referred to in Article 20(m) of Regulation (EU) No 1308/2013, of the products and quantities in respect of which the storage period has been revised, and of the initial and revised dates for removal from storage;
- (c) by 31 March each year for the preceding calendar year, of the results of the on-the-spot checks carried out pursuant to Title IV.

Status: Point in time view as at 07/02/2018.

Changes to legislation: There are currently no known outstanding effects for the Commission Implementing Regulation (EU) 2016/1240. (See end of Document for details)

CHAPTER II

Final provisions

Article 67

Entry into force and application

This Regulation shall enter into force on the seventh day following that of its publication in the *Official Journal of the European Union*.

It shall apply as from 1 October 2016. However, as regards buying-in to public intervention, Tables III and IV of Part V and Point (b) of Part VI of Annex I shall apply as of 1 July 2017.

This Regulation shall be binding in its entirety and directly applicable in all Member States.

Status: Point in time view as at 07/02/2018.

Changes to legislation: There are currently no known outstanding effects for the Commission Implementing Regulation (EU) 2016/1240. (See end of Document for details)

ANNEX I

CEREALS

PART I

1. DEFINITION OF MATTER OTHER THAN BASIC CEREALS OF UNIMPAIRED QUALITY

1.1. **Broken grains**

For durum wheat, common wheat and barley, the definition of ‘broken grains’ is that contained in standard EN 15587.

For maize, the definition of ‘broken grains’ is that contained in standard EN 16378.

1.2. **Grain impurities**

(a) *Shrivelled grains*

For durum wheat, common wheat and barley, the definition of ‘shrivelled grains’ is that contained in standard EN 15587. However, for barley from Estonia, Latvia, Finland and Sweden, ‘shrivelled grains’ means grains with a specific weight of at least 64 kilograms per hectolitre offered or tendered for, or placed in, intervention in those Member States, grains which, after elimination of all other matter referred to in this Annex, pass through sieves with apertures of 2,0 mm.

‘Shrivelled grains’ does not apply to maize.

(b) *Other cereals*

For durum wheat, common wheat and barley, the definition of ‘other cereals’ is that contained in standard EN 15587.

For maize, the definition of ‘other cereals’ is that contained in standard EN 16378.

(c) *Grains damaged by pests*

For durum wheat, common wheat and barley, the definition of ‘grains damaged by pests’ is that contained in standard EN 15587.

For maize, the definition of ‘grains damaged by pests’ is that contained in standard EN 16378.

(d) *Grains in which the germ is discoloured*

For durum wheat and common wheat, the definition is that contained in standard EN 15587.

‘Grains in which the germ is discoloured’ does not apply to barley or maize.

(e) *Grains overheated during drying*

For durum wheat, common wheat and barley, the definition of ‘grains overheated during drying’ is that contained in standard EN 15587.

For maize, the definition of ‘grains overheated during drying’ is that contained in standard EN 16378..

(f) *Mottled grains*

For durum wheat, the definition of ‘mottled grains’ is that contained in standard EN 15587.

Status: Point in time view as at 07/02/2018.

Changes to legislation: There are currently no known outstanding effects for the Commission Implementing Regulation (EU) 2016/1240. (See end of Document for details)

‘Mottled grains’ does not apply to common wheat, barley or maize.

1.3. **Sprouted grains**

For durum wheat, common wheat and barley, the definition of ‘sprouted grains’ is that contained in standard EN 15587.

For maize, the definition of ‘sprouted grains’ is that contained in standard EN 16378.

1.4. **Miscellaneous impurities**

(a) *Extraneous seeds*

For durum wheat, common wheat and barley, the definition of ‘extraneous seeds’ is that contained in standard EN 15587.

For maize, the definition of ‘extraneous seeds’ is that contained in standard EN 16378.

‘Noxious seeds’ means seeds which are toxic to humans and animals, seeds hampering or complicating the cleaning and milling of cereals and seeds affecting the quality of products processed from cereals.

(b) *Damaged grains*

For durum wheat, common wheat and barley, the definition of ‘damaged grains’ is that contained in standard EN 15587.

For maize, the definition of ‘damaged grains’ is that contained in standard EN 16378.

In standard EN 15587, for durum wheat, common wheat and barley, the definition of ‘grains affected by fusariosis’ is included in that of ‘damaged grains’.

(c) *Extraneous matter*

For durum wheat, common wheat and barley, the definition of ‘extraneous matter’ is that contained in standard EN 15587.

For maize, the definition of ‘extraneous matter’ is that contained in standard EN 16378.

(d) *Husks (cob fragments in the case of maize)*

(e) *Ergots*

(f) *Decayed grains*

For durum wheat and common wheat, the definition of ‘decayed grains’ is that contained in standard EN 15587.

‘Decayed grains’ does not apply to barley or maize.

(g) *Impurities of animal origin.*

1.5. **Live pests**

1.6. **Mitadiné grains**

Mitadiné grains of durum wheat are grains whose kernels cannot be regarded as entirely vitreous. They are defined in standard EN 15585.

2. **SPECIFIC FACTORS TO TAKE INTO CONSIDERATION FOR EACH TYPE OF CEREAL FOR THE DEFINITION OF IMPURITIES**

Status: Point in time view as at 07/02/2018.

Changes to legislation: There are currently no known outstanding effects for the Commission Implementing Regulation (EU) 2016/1240. (See end of Document for details)

2.1. Durum wheat

‘Grain impurities’ means shrivelled grains, grains of other cereals, grains damaged by pests, grains in which the germ is discoloured, mottled grains and grains overheated during drying.

‘Miscellaneous impurities’ means extraneous seeds, damaged grains (including grains affected by fusariosis), extraneous matter, husks, ergot, decayed grains and impurities of animal origin.

2.2. Common wheat

‘Grain impurities’ means shrivelled grains, grains of other cereals, grains damaged by pests, grains in which the germ is discoloured (only where the content exceeds 8 %) and grains overheated during drying.

‘Miscellaneous impurities’ means extraneous seeds, damaged grains (including grains affected by fusariosis), extraneous matter, husks, ergot, decayed grains and impurities of animal origin.

2.3. Barley

‘Grain impurities’ means shrivelled grains, grains of other cereals, grains damaged by pests and grains overheated during drying.

‘Miscellaneous impurities’ means extraneous seeds, damaged grains (including grains affected by fusariosis), extraneous matter, husks and impurities of animal origin.

2.4. Maize

‘Grain impurities’ means grains of other cereals, grains damaged by pests and grains overheated during drying.

‘Miscellaneous impurities’ means extraneous seeds, damaged grains, extraneous matter, cob fragments and impurities of animal origin.

PART II Methods used for determining the quality of cereals offered or tendered for, or placed in, intervention

Pursuant to Article 4, the following methods are to be used to determine the quality of cereals offered or tendered for, or placed in, intervention:

- (a) reference method for determining matter other than basic cereals of unimpaired quality:
 - (i) for common wheat, durum wheat and barley: standard EN 15587,
 - (ii) for maize: standard EN 16378;
- (b) reference method for determining the moisture content:
 - (i) for maize: standard EN ISO 6540,
 - (ii) for cereals other than maize: standard EN ISO 712, or an infrared technology-based method complying with standard EN 15948.

In the event of a dispute, only the results resulting from applying standard EN ISO 6540 for maize and standard EN ISO 712 for cereals other than maize are to be considered valid;

- (c) reference method for determining the non-stickiness and machinability of the dough obtained from common wheat: that set out in Part III of this Annex;

Status: Point in time view as at 07/02/2018.

Changes to legislation: There are currently no known outstanding effects for the Commission Implementing Regulation (EU) 2016/1240. (See end of Document for details)

- (d) reference method for determining the protein content in durum wheat and ground common wheat: that set out in:
 - (i) standard EN ISO 20483, or
 - (ii) standard CEN ISO/TS 16634-2.

In the event of a dispute, only the results obtained from applying standard EN ISO 20483 are to be considered valid;
- (e) reference method for determining the Zeleny index of ground common wheat: that set out in standard EN ISO 5529;
- (f) reference method for determining the Hagberg falling number (amylase activity test): that set out in standard EN ISO 3093;
- (g) reference method for determining the rate of loss of the vitreous aspect of durum wheat: that set out in standard EN 15585;
- (h) reference method for determining the specific weight: that set out in standard EN ISO 7971/3;
- (i) sampling and analysis methods for establishing the rate of mycotoxins: those referred to in the Annex to Commission Regulation (EC) No 1881/2006⁽²¹⁾ and set out in Annexes I and II to Commission Regulation (EC) No 401/2006⁽²²⁾.

PART III Method for determining the non-stickiness and machinability of the dough obtained from common wheat 1. Title

Method for test baking of wheat flour.

2. Scope

The method is applicable to flour, experimentally milled from wheat for the production of yeast-raised bread.

3. Principle

Dough is made from flour, water, yeast, salt and sucrose, in a specified mixer. After dividing and rounding, the pieces are given 30 minutes' rest; they are moulded, placed on baking sheets and baked after a final proof of fixed duration. Dough-handling properties are noted. The loaves are judged by volume and height.

4. Ingredients 4.1. Yeast

Active dry yeast of type *Saccharomyces cerevisiae* DHW-Hamburg-Wansbeck or a product having the same characteristics.

4.2. Tap water 4.3. Sugar-salt-ascorbic acid solution

Dissolve $30 \pm 0,5$ g of sodium chloride (commercial grade), $30 \pm 0,5$ g of sucrose (commercial grade), and $0,040 \pm 0,001$ g ascorbic acid in 800 ± 5 g of water. Prepare fresh daily.

4.4. Sugar solution

Dissolve $5 \pm 0,1$ g sucrose (commercial grade) in 95 ± 1 g of water. Prepare fresh daily.

4.5. Enzyme active malt flour

Commercial grade.

5. Equipment and apparatus 5.1. Baking room

Status: Point in time view as at 07/02/2018.

Changes to legislation: There are currently no known outstanding effects for the Commission Implementing Regulation (EU) 2016/1240. (See end of Document for details)

Controlled to maintain a temperature of 22 to 25 °C.

5.2.Refrigerator

For maintaining a temperature of 4 ± 2 °C.

5.3.Balance

Maximum load 2 kg, accuracy 2 g.

5.4.Balance

Maximum load 0,5 kg, accuracy 0,1 g.

5.5.Analytical balance

Accuracy $0,1 \times 10^{-3}$ g.

5.6.Mixer

Stephan UMTA 10, with mixing arm model 'Detmold' (Stephan Soehne GmbH) or similar equipment having the same characteristics.

5.7.Proving cabinet

Controlled to maintain a temperature of 30 ± 1 °C.

5.8.Open plastic boxes

Made from polymethylmethacrylate (Plexiglas, Perspex). Inside dimensions: 25 × 25 × 15 cm height, wall thickness $0,5 \pm 0,05$ cm.

5.9.Square plastic sheets

Made from polymethylmethacrylate (Plexiglas, Perspex). At least 30 × 30 cm, thickness $0,5 \pm 0,05$ cm.

5.10.Moulder

Brabender ball homogeniser (Brabender OHG) or similar equipment having the same characteristics.

6.Sampling

According to standard EN ISO 24333.

7.Procedure7.1.Determination of water uptake

Determine the water absorption according to ICC Standard No 115/1.

7.2.Determination of malt flour addition

Determine the 'falling number' of the flour according to standard EN ISO 3093. If the 'falling number' is higher than 250, determine the malt flour addition required to bring it within the range 200 to 250, using a series of mixtures of the flour with increasing quantities of malt flour (point 4.5). If the 'falling number' is lower than 250, no malt flour is required.

7.3.Reactivation of active dry yeast

Adjust the temperature of the sugar solution (point 4.4) to 35 ± 1 °C. Pour one part by weight of the active dry yeast into four parts by weight of this tempered sugar solution. Do not stir. Swirl if necessary.

Allow to stand for 10 ± 1 minute, then stir until a homogeneous suspension is obtained. Use this suspension within 10 minutes.

7.4.Temperature adjustment of the flour and the dough liquid

The temperature of the flour and the water must be adjusted to give a dough temperature of 27 ± 1 °C after mixing.

Status: Point in time view as at 07/02/2018.

Changes to legislation: There are currently no known outstanding effects for the Commission Implementing Regulation (EU) 2016/1240. (See end of Document for details)

7.5. Dough composition

Weigh, with a precision of 2 g, 10 y/3 g flour on as-is moisture basis (corresponding to 1 kg flour on a 14 % moisture basis), in which 'y' is the quantity of flour used in the farinograph test (see ICC Standard No 115/1).

Weigh, with a precision of 0,2 g, the quantity of malt flour necessary to bring the 'falling number' within the range 200 to 250 (point 7.2).

Weigh 430 ± 5 g sugar-salt-ascorbic acid solution (point 4.3) and add water to a total mass of $(x - 9) 10 y/3$ g, (see point 10.2) in which 'x' is the quantity of water used in the farinograph test (see ICC Standard No 115/1). This total mass (usually between 450 and 650 g) must be achieved with a precision of 1,5 g.

Weigh 90 ± 1 g yeast suspension (point 7.3).

Note the total mass of the dough (P), which is the sum of the masses of flour, sugar-salt-ascorbic acid solution plus water, yeast suspension and malt flour.

7.6. Mixing

Before starting, bring the mixer to a temperature of 27 ± 1 °C by use of a suitable quantity of tempered water.

Place the liquid dough ingredients in the mixer and place the flour plus malt flour on top.

Start the mixer (speed 1, 1 400 rev/min), and allow to run for 60 seconds. Twenty seconds after the start of mixing, turn the scraper attached to the lid of the mixing bowl two revolutions.

Measure the temperature of the dough. If it is outside the range 26 to 28 °C, discard the dough and mix a new one after adjustment of ingredient temperatures.

Note dough properties using one of the following terms:

- non-sticky and machinable, or
- sticky and non-machinable.

To be considered 'non-sticky and machinable' at the end of mixing, the dough should form a coherent mass which hardly adheres to the sides of the bowl and spindle of the mixer. It should be possible to collect the dough by hand and remove it from the mixing bowl in a single motion without noticeable loss.

7.7. Dividing and rounding

Weigh, with precision of 2 g, three pieces of dough according to the formula:

$$\begin{array}{rcl} p & = & 0,25 P, \text{ where:} \\ p & = & \text{mass of scaled dough piece,} \\ P & = & \text{total mass of dough.} \end{array}$$

Immediately round the pieces for 15 seconds in the moulder (point 5.10) and place them for 30 ± 2 minutes on the square plastic sheets (point 5.9), covered by the inverted plastic boxes (point 5.8) in the proving cabinet (point 5.7).

Do not use dusting flour.

7.8. Moulding

Bring the pieces of dough on the plastic sheets, covered by the inverted boxes, to the moulder (point 5.10), and re-round each piece for 15 seconds. Do not remove cover

Status: Point in time view as at 07/02/2018.

Changes to legislation: There are currently no known outstanding effects for the Commission Implementing Regulation (EU) 2016/1240. (See end of Document for details)

from a piece of dough until immediately before rounding. Note dough properties again, using one of the following terms:

- (a) non-sticky and machinable, or
- (b) sticky and non-machinable.

To be considered as 'non-sticky and machinable' the dough should adhere hardly, or not at all, to the sides of the chamber so that it can freely rotate around itself and form a regular ball during the operation of the machine. At the end of the operation the dough should not stick to the sides of the dough-moulding chamber when the lid of the chamber is raised.

8. Test report

The test report shall mention:

- (a) dough-handling properties at the end of mixing, and at moulding,
- (b) the 'falling number' of the flour without addition of malt flour,
- (c) any anomalies observed.
- (d) the method used,
- (e) all details required for the identification of the sample.

9. General remarks
9.1. The formula for the calculation of the quantity of dough liquid is based on the following considerations:

Addition of x ml water to the equivalent of 300 g flour at 14 % moisture produces the required consistency. As in the baking test 1 kg of flour (14 % moisture basis) is used, whereas x is based on 300 g of flour, for the baking test x divided by three and multiplied by 10 g of water is needed, so $10 x/3$ g.

The 430 g sugar-salt-ascorbic acid solution contains 15 g salt and 15 g sugar. This 430 g solution is included in the dough liquid. So to add $10 x/3$ g water to the dough, $(10 x/3 + 30)$ g dough liquid composed of the 430 g sugar-salt-ascorbic acid solution and an additional quantity of water must be added.

Although part of the water added with the yeast suspension is absorbed by the yeast, this suspension also contains 'free' water. It is arbitrarily supposed that 90 g yeast suspension contains 60 g 'free' water. The quantity of the dough liquid must be corrected for this 60 g of 'free' water in the yeast suspension, so $10 x/3$ plus 30 minus 60 g must finally be added. This can be rearranged as follows: $(10 x/3 + 30) - 60 = 10 x/3 - 30 = (x/3 - 3) 10 = (x - 9) 10/3$, the formula given in point 7.5. If, for example, a water addition x in the farinograph test was found of 165 ml, this value must be substituted in this formula, so to the 430 g sugar-salt-ascorbic acid solution water must be added to a total mass of:

$$(165 - 9) 10/3 = 156 \times 10/3 = 520 \text{ g.}$$

9.2. The method is not directly applicable to wheat. The procedure to be followed for characterising the baking properties of wheat is as follows:

Clean the wheat sample, and determine the moisture content of the cleaned wheat. If the moisture content is within the range 15,0 % to 16,0 %, do not temper the wheat. If the moisture content is outside this range, adjust the moisture content to $15,5 \pm 0,5$ %, at least three hours prior to milling.

Status: Point in time view as at 07/02/2018.

Changes to legislation: There are currently no known outstanding effects for the Commission Implementing Regulation (EU) 2016/1240. (See end of Document for details)

Mill the wheat into flour using a Buehler laboratory mill MLU 202 or a Brabender Quadrumat Senior mill or similar equipment having the same characteristics.

Choose a milling procedure that yields a flour of minimum 72 % extraction, with an ash content of 0,50 to 0,60 % on dry matter basis.

Determine the ash content of the flour according to Annex II to Commission Regulation (EU) No 234/2010⁽²³⁾ and the moisture content according to this Regulation. Calculate the extraction rate by the equation:

$$E = (((100 - f) F) / (100 - w) W) \times 100 \%$$

where:

E	=	extraction rate,
f	=	moisture of the flour,
w	=	moisture content of the wheat,
F	=	mass of flour produced with moisture content f,
W	=	mass of wheat milled with moisture content w.

Note: Information concerning the ingredients and equipment to be used is published in Document T/77,300 of 31 March 1977 from the Instituut voor Graan, Meel en Brood, TNO — Postbus 15, Wageningen, Netherlands.

PART IV Methodology of sampling and analyses for cereals¹.

For each lot of cereals, the quality characteristics shall be established on the basis of a representative sample of the lot offered, consisting of samples taken at the rate of once every delivery for at least every 60 tonnes.

2.

The reference methods to be used for determining the quality of cereals offered or tendered for, or placed in, intervention are those set out in Parts I, II and III of this Annex.

3.

In cases of dispute, the paying agency shall have the necessary tests on the cereals in question carried out again, the cost being met by the losing party.

PART V	Price increases and reductions	Table I	Price increases for moisture content for cereals other than maize	Moisture content(%)	Increases(EUR/tonne)	Less than 12,5 to 120,5	Less than 12 to 11,5	1	Less than 11,5 to 11,51	Price increases for moisture content for maize	Moisture content(%)	Increases(EUR/tonne)	Less than 12 to 11,5	0,5	Less than 11,51	Table II	Price reductions for moisture content for cereals other than maize	Moisture content(%)	Reduction(EUR/tonne)	More than 13,0 to 13,5	0,5	More than 13,5 to 14,0	1,0	More than 14,0 to 14,5	1,5	Price reductions for moisture content for maize	Moisture content(%)	Reduction(EUR/tonne)	More than 12,5 to 13,0	0,5	More than 13,0 to 13,5	1,0
--------	--------------------------------	---------	---	---------------------	----------------------	-------------------------	----------------------	---	-------------------------	--	---------------------	----------------------	----------------------	-----	-----------------	----------	--	---------------------	----------------------	------------------------	-----	------------------------	-----	------------------------	-----	---	---------------------	----------------------	------------------------	-----	------------------------	-----

TABLE III

Price increases for protein content of common wheat

Protein content ^a (N × 5,7)	Price increase(EUR/tonne)
More than 12,0	2,5

a As % of dry matter.

Status: Point in time view as at 07/02/2018.

Changes to legislation: There are currently no known outstanding effects for the Commission Implementing Regulation (EU) 2016/1240. (See end of Document for details)

TABLE IV

Price reductions for protein content for common wheat

Protein content^a(N × 5,7)	Price reduction(EUR/tonne)
Less than 11,5 to 11,0	2,5

a As % of dry matter.

PART VI Calculation of prices increases and reductions

The price adjustments provided for in Article 26(1) shall be expressed in euro per tonne for offers or tenders for intervention by multiplying the price referred to in that Article by the sum of the established percentage increases or reductions, as follows:

- (a) where the moisture content of cereals offered or tendered for intervention is less than 12,0 % for maize and 12,5 % for other cereals, the price increases to be applied shall be those listed in Table I of Part V of this Annex. Where the moisture content of these cereals offered or tendered for intervention is higher than 12,5 % for maize and 13,0 % for other cereals, the price reductions to be applied shall be those listed in Table II of Part V of this Annex;
- (b) where the protein content of common wheat is higher than 12,0 %, the increases to be applied shall be those listed in Table III of Part V of this Annex. Where the protein content of common wheat is less than 11,5 %, the reductions to be applied shall be those listed in Table IV of Part V of this Annex.

ANNEX II

RICE

PART I

Methodology of sampling and analyses for paddy rice

1. With a view to verifying the quality requirements as laid down in Part I of Annex II to Delegated Regulation (EU) 2016/1238, samples shall be taken by the paying agency in the presence of the operator or his/her duly authorised agent.

Three representative samples, each weighing a minimum of one kilogram, shall be collected. One each shall go to:

- (a) the operator;
- (b) the storage place where takeover is to take place;
- (c) the paying agency.

To make up the representative samples, the number of individual samples to be taken shall be obtained by dividing the quantity of the lot by 10 tonnes. Each individual sample shall weigh

Status: Point in time view as at 07/02/2018.

Changes to legislation: There are currently no known outstanding effects for the Commission Implementing Regulation (EU) 2016/1240. (See end of Document for details)

the same. The representative samples shall be made up of the sum of the individual samples, divided by three.

The quality requirements shall be verified using the representative sample intended for the store where takeover is to take place.

2. Representative samples shall be taken of each part-delivery (by lorry, barge, railway wagon) under the conditions laid down in point 1.

Before its entry into the intervention store the examination of each part-delivery can be restricted to a check of the moisture content and impurity level and verification that no live insects are present. However, if it later becomes apparent when the check is finalised that a part-delivery does not satisfy the minimum quality requirements, the concerned quantity shall be refused for takeover. If the paying agency is able to check all the minimum quality requirements for each part-delivery before it enters the store, it shall refuse takeover of any part-delivery that fails to satisfy these requirements.

3. The control of the radioactivity level is performed only if the situation so requires and for a limited period.
4. In cases of dispute, the paying agency shall have the necessary tests on the paddy rice in question carried out again, the cost being met by the losing party.

A new analysis is performed by a laboratory recognised by the paying agency on the basis of a new representative sample made up, in equal parts, by samples preserved by the operator and by the paying agency. In cases where there were part-deliveries of the lot tendered, the result is given by the weighted average of the results of analyses of new representative samples taken for each of the part-deliveries.

PART II

Prices increases and reductions

1. The price adjustments provided for in Article 26(1) shall be expressed in euro per tonne and apply to tenders for intervention by multiplying the price referred to in that Article by the sum of the established percentage increases in Tables I, II and III of this Part.
2. The price increases and decreases shall apply on the basis of the weighted average of the test results on the representative samples as defined in Part I of this Annex.

TABLE I

Price increases for moisture content

Moisture content(%)	Increases(EUR/tonne)
Less than 12,5 to 12	0,75
Less than 12 to 11,5	1,5

TABLE II

Price reductions for moisture content

Moisture content(%)	Reduction(EUR/tonne)
More than 13,5 to 14,0	0,75

Status: Point in time view as at 07/02/2018.

Changes to legislation: There are currently no known outstanding effects for the Commission Implementing Regulation (EU) 2016/1240. (See end of Document for details)

More than 14,0 to 14,5	1,5
------------------------	-----

TABLE III

Price increases relating to milling yield

Yield of whole-grain milled paddy rice	Price increases per yield point^a
Above the basic yield	0,75 % increase
Overall yield of milled paddy rice	Price increases per yield point
Above the basic yield	0,60 % increase

^a To be applied where the milling yield of the rice differs from the basic milling yield for the variety concerned as set out in Part II of Annex II to Delegated Regulation (EU) 2016/1238.

ANNEX III

BEEF

PART I

Conditions and controls for taking over

1. Products delivered shall be taken over subject to verification by the paying agency that they comply with the requirements laid down in Part I of Annex III to Delegated Regulation (EU) 2016/1238. In particular, a systematic check of the presentation, classification, weight and labelling of each carcass, half-carcass and quarter delivered shall be undertaken.
2. The failure to comply with the requirements laid down in Part I of Annex III to Delegated Regulation (EU) 2016/1238 shall result in rejection. Products rejected shall not be presented again for acceptance.
3. The outcome of the checks described in point 1 shall be systematically recorded by the paying agency.

PART II

Conversion coefficients

Conformation class/fat cover	Coefficient
U2	1,058
U3	1,044
U4	1,015
R2	1,015
R3	1,000
R4	0,971

Status: Point in time view as at 07/02/2018.

Changes to legislation: There are currently no known outstanding effects for the Commission Implementing Regulation (EU) 2016/1240. (See end of Document for details)

O2	0,956
O3	0,942
O4	0,914

PART III

Deboning

I. General conditions governing deboning

1. Deboning may only be carried out in cutting plants approved and operating in accordance with the requirements of Regulation (EC) No 853/2004 of the European Parliament and of the Council⁽²⁴⁾.
2. For the purposes of this Regulation ‘deboning operations’ means the physical operations for beef/veal as referred to in Annex II to Delegated Regulation (EU) No 906/2014.
3. Boned cuts must meet the requirements laid down in Part IV of this Annex.

II. Contracts and specifications

1. Deboning shall be carried out under contract on terms laid down by the paying agencies, in accordance with their specifications and in compliance with the requirements of this Regulation.
2. The specifications of the paying agencies shall lay down the requirements to be met by cutting plants, shall specify the plant and equipment required and shall lay down detailed conditions covering deboning operations.

They shall in particular lay down detailed conditions specifying the method of preparation, trimming, packing, freezing and preservation of cuts with a view to their takeover by the paying agency.

III. Control and monitoring of deboning operations

The paying agencies shall take all the necessary measures to ensure that deboning operations are carried out in compliance with the requirements of this Regulation and with the contracts and specifications described in Section II of this Part.

In particular, the paying agencies shall put in place a system to ensure the continuous monitoring and verification of all deboning operations. The outcome of such monitoring and verification shall be recorded.

IV. Storage of cuts

Cuts shall be stored in cold stores located in the territory of the Member State exercising jurisdiction over the paying agency.

V. Costs of deboning operations

Contracts as referred to in Section II of this Part and payments made thereunder shall cover the costs of deboning operations as referred to in point 2 of Section I of this Part.

VI. Time limits for deboning operations

Status: Point in time view as at 07/02/2018.

Changes to legislation: There are currently no known outstanding effects for the Commission Implementing Regulation (EU) 2016/1240. (See end of Document for details)

Deboning, trimming, weighing, packaging and rapid freezing must be completed within 10 calendar days of slaughter. However, the paying agency may set shorter time limits.

VII. Checks and rejection of products

1. When as a result of the checks provided for in Section III of this Part, products are found not to be in compliance with the requirements as laid down in this Regulation and with the contracts and specifications described in Section II of this Part they shall be rejected.
2. Without prejudice to the application of penalties, the paying agencies shall recover payments from the responsible parties for an amount equal to the price shown in Part V of this Annex for the cuts that have been rejected.

PART IV

Specifications for intervention deboning

1. HINDQUARTER CUTS

1.1. Description of cuts

1.1.1. Intervention shank (code INT 11)

Cutting and deboning: remove by a cut passing through the stifle joint and separating from the topside and the silverside by following the natural seam, leaving the heel muscle attached to the shank. Remove shank bones (tibia and hock).

Trimming: trim sinew tips back to the meat.

Wrapping and packing: these cuts must be individually wrapped before packing in cartons.

1.1.2. Intervention thick flank (code INT 12)

Cutting and deboning: separate from the topside by a straight cut down to and along the line of the femur and from the silverside by continuing the cut down in the line of the natural seam; the cap must be left naturally attached.

Trimming: remove the patella, the joint capsule and tendon; the external fat cover must not exceed one centimetre at any point.

1.1.3. Intervention topside (code INT 13)

Cutting and deboning: separate from the silverside and the shank by a cut following the line of the natural seam and detach from the femur; remove the aitchbone.

Trimming: remove the pizzle butt, the adjacent gristle and the scrotal (superficial inguinal) gland; remove the cartilage and connective tissues associated with the pelvic bone; the external fat cover must not exceed one centimetre at any point.

1.1.4. Intervention silverside (code INT 14)

Cutting and deboning: separate from the topside and the shank by a cut following the line of the natural seam; remove the femur.

Trimming: remove the heavy cartilage adjacent to the bone joint, the popliteal lymph node, attached fat and tendon; the external fat cover must not exceed one centimetre at any point.

Status: Point in time view as at 07/02/2018.

Changes to legislation: There are currently no known outstanding effects for the Commission Implementing Regulation (EU) 2016/1240. (See end of Document for details)

1.1.5. Intervention fillet (code INT 15)

Cutting: remove entire length of fillet by freeing the head (butt end) from the hip bone (ilium) and by tracing along the fillet adjacent to the vertebrae, thereby freeing the fillet from the loin.

Trimming: remove gland and de-fat. Leave the silverskin and chain muscle intact and fully attached.

1.1.6. Intervention rump (code INT 16)

Cutting and deboning: separate from the silverside/thick flank by a straight cut from a point approximately five centimetres from the posterior edge of the fifth sacral vertebra, passing approximately five centimetres from the anterior edge of the aitchbone, taking care not to cut through the thick flank.

Separate from the loin by a cut between the last lumbar and first sacral vertebrae, clearing the anterior edge of the pelvic bone. Remove bones and cartilage.

Trimming: remove the pocket of fat on the internal surface below the eye muscle. The external fat cover must not exceed one centimetre at any point.

1.1.7. Intervention striploin (code INT 17)

Cutting and deboning: separate from the rump by a straight cut between the last lumbar and the first sacral vertebrae. Separate from the fore-rib (five bone) by a straight cut between the eleventh and tenth ribs. Remove the backbones cleanly. Remove the ribs and feather bones by sheeting out.

Trimming: remove any species of cartilage left after deboning. The tendon must be removed. The external fat cover must not exceed one centimetre at any point.

1.1.8. Intervention flank (code INT 18)

Cutting and deboning: remove the full flank from the eight-rib straight-cut hindquarter by a cut from the point where the flank has been laid back, following the natural seam down around the surface of the hind muscles to a point which is horizontal to the middle of the last lumbar vertebra.

Continue the cut downwards in a straight line parallel to the fillet, through the thirteenth to the sixth rib inclusive along a line running parallel to the dorsal edge of the vertebral column, so that the entire downward cut is no more than five centimetres from the lateral tip of the eye muscle.

Remove all bones and cartilage by sheeting out. The whole flank must remain in one piece.

Trimming: remove the coarse connective tissue sheath covering the goose skirt, leaving the goose skirt intact. Trim fat so that the overall percentage of visible (external and interstitial) fat does not exceed 30 %.

1.1.9. Intervention fore-rib (five bone) (code INT 19)

Cutting and deboning: this cut must be separated from the striploin by a straight cut between the eleventh and tenth ribs and must include the sixth to tenth ribs inclusive. Remove the intercostal muscles and pleura in a thin sheet with rib bones. Remove backbone and cartilage, including the tip of the scapula.

Trimming: remove the backstrap (ligamentum nuchae). The external fat cover must not exceed one centimetre at any point. The cap must be left attached.

Status: Point in time view as at 07/02/2018.

Changes to legislation: There are currently no known outstanding effects for the Commission Implementing Regulation (EU) 2016/1240. (See end of Document for details)

2. FOREQUARTER CUTS

2.1. Description of cuts

2.1.1. Intervention shin (code INT 21)

Cutting and deboning: remove by a cut around the joint separating the shinbone (radius) and clod-bone (humerus). Remove the shinbone (radius).

Trimming: trim sinew tips back to the meat.

Shins must not be packed with shanks.

2.1.2. Intervention shoulder (code INT 22)

Cutting and deboning: separate the shoulder from the forequarter by cutting in a line following the natural seam around the edge of the shoulder and the cartilage at the tip of the scapula, continuing around the seam so that the shoulder is lifted from its natural pocket. Remove the scapula. The blade muscle under the scapula must be laid back but left attached so as to allow clean removal of the bone. Remove the clod-bone (humerus).

Trimming: remove cartilage, tendons and joint capsules; trim fat so that the overall percentage of visible (external and interstitial) fat does not exceed 10 %.

2.1.3. Intervention brisket (code INT 23)

Cutting and deboning: separate from the forequarter by cutting in a straight line perpendicular to the middle of the first rib. Remove intercostal muscles and pleura by 'sheeting out', with ribs, breastbone and cartilage. Deckle to be left attached to the brisket. Fat underlying the deckle and the sternum must be removed.

Trimming: trim fat so that the overall percentage of visible (external and interstitial) fat does not exceed 30 %.

2.1.4. Intervention forequarter (code INT 24)

Cutting and deboning: the cut remaining after removal of the brisket, shoulder and shin is classed as forequarter.

Remove rib bones by sheeting out. Neck bones must be removed cleanly.

The chain muscle must be left attached to this cut.

Trimming: tendons, joint capsules and cartilage to be removed. Trim fat so that the overall percentage of visible (external and interstitial) fat does not exceed 10 %.

PART V

Individual prices of rejected intervention cuts

<i>(EUR/tonne)</i>	
Intervention fillet	22 000
Intervention striploin	14 000
Intervention topside, Intervention rump	10 000

Status: Point in time view as at 07/02/2018.

Changes to legislation: There are currently no known outstanding effects for the Commission Implementing Regulation (EU) 2016/1240. (See end of Document for details)

Intervention silverside, Intervention thick flank, Intervention forerib (with five ribs)	8 000
Intervention shoulder, Intervention forequarter	6 000
Intervention brisket, Intervention shank, Intervention shin	5 000
Intervention flank	4 000

ANNEX IV

BUTTER

PART I

Sampling for chemical and microbiological analysis and sensory evaluation

1. Chemical and microbiological analysis

Quantity of butter(kg)	Minimum number of samples(> 100 g)
≤ 1 000	2
> 1 000 ≤ 5 000	3
> 5 000 ≤ 10 000	4
> 10 000 ≤ 15 000	5
> 15 000 ≤ 20 000	6
> 20 000 ≤ 25 000	7
> 25 000	7 + 1 per 25 000 kg or part thereof

Sampling for microbiological analysis must be carried out aseptically.

Up to five samples of 100 g may be combined into one sample for analysis after thorough mixing.

The samples must be taken randomly from different parts of each lot before or at the time of entry into the cold store designated by the paying agency.

Preparation of composite butter sample (chemical analysis):

- (a) using a clean, dry butter trier or similar suitable instrument, extract a core of butter of at least 30 g and place in a sample container. The composite sample must then be sealed and forwarded to the laboratory for analysis;
- (b) at the laboratory the composite sample is to be warmed in the original unopened container to 30 °C and shaken frequently until a homogeneous fluid emulsion free of unsoftened pieces is obtained. The container should be one half to two thirds full.

Status: Point in time view as at 07/02/2018.

Changes to legislation: There are currently no known outstanding effects for the Commission Implementing Regulation (EU) 2016/1240. (See end of Document for details)

Two samples per year per producer offering butter for intervention must be analysed for non-milk fat.

2. Sensory evaluation

Quantity of butter(kg)	Minimum number of samples
$1\ 000 \leq 5\ 000$	2
$> 5\ 000 \leq 25\ 000$	3
$> 25\ 000$	3 + 1 per 25 000 kg or part thereof

Following a trial storage period of 30 days, samples are to be taken randomly from different parts of each lot between the 30th and the 45th day following delivery of the butter and graded.

[^{F1}Each sample shall be assessed individually. No resampling or re-evaluation is allowed.]

3. Guidelines to be followed where samples show defects

- (a) chemical and microbiological analysis:
- (i) where individual samples are analysed, one sample showing a single defect out of five to 10 samples or two samples each showing a single defect out of 11 to 15 samples may be allowed. Where a sample shows a defect, two new samples must be taken from either side of the sample showing the defect and checked for the parameter in question. Where neither sample meets the specification, the quantity of butter between the original two samples on either side of the sample showing the defect must be rejected from the quantity offered.

Quantity to be rejected where the new sample shows a defect:

- (ii) where composite samples are analysed and found to show defects in respect of one parameter, the quantity represented by the composite sample concerned is to be rejected from the quantity offered. The quantity represented by one composite sample may be determined by subdividing the quantity before samples are taken randomly from each part thereof;
- (b) sensory evaluation: where a sample fails the sensory evaluation, the quantity of butter between two neighbouring samples on either side of the sample failing is to be rejected from the quantity of the lot,
- (c) where samples show a sensory defect and either a chemical or a microbiological defect, the whole quantity is to be rejected.

[^{F3}PART IA

Methods of analysis of unsalted butter for public intervention

Parameter	Method
Fat ^a	ISO 17189 or ISO 3727 part 3
Water	ISO 3727 part 1

^a The method to be applied shall be approved by the paying agency.

Status: Point in time view as at 07/02/2018.

Changes to legislation: There are currently no known outstanding effects for the Commission Implementing Regulation (EU) 2016/1240. (See end of Document for details)

Non-fat solids	ISO 3727 part 2
Fat acidity	ISO 1740
Peroxide value	ISO 3976
Non-milk fat	ISO 17678
Sensory characteristics	ISO 22935 parts 2 and 3 and scoring table hereafter.

a The method to be applied shall be approved by the paying agency.

Scoring table

Appearance		Consistency		Odour and Flavour	
Points	Remarks	Points	Remarks	Points	Remarks
5	<i>Very good</i> Ideal type Highest quality (equal dry)	5	<i>Very good</i> Ideal type Highest quality (equal spreadable)	5	<i>Very good</i> Ideal type Highest quality (absolutely pure finest odour)
4	<i>Good</i> (no evident defects)	4	<i>Good</i> (no evident defects)	4	<i>Good</i> (no evident defects)
1, 2 or 3	Any defect	1, 2 or 3	Any defect	1, 2 or 3	Any defect]

PART II

Delivery and packaging of butter

1. Butter shall be delivered in blocks and packed in new, strong material in such a way as to ensure it is protected throughout transportation, entry into storage, storage and removal from storage.
2. The packing shall show at least the following particulars, where appropriate in code:
 - (a) the approval number identifying the factory and the Member State of production;
 - (b) the date of production;
 - (c) the production batch number and the package number; the package number may be replaced by a pallet number marked on the pallet;
 - (d) the words 'sweet cream' if the butter has a pH of 6,2 or higher.
3. The storekeeper shall keep a register in which the particulars referred to in point 2 are recorded on the date of entry into storage.

Status: Point in time view as at 07/02/2018.

Changes to legislation: There are currently no known outstanding effects for the Commission Implementing Regulation (EU) 2016/1240. (See end of Document for details)

ANNEX V

SKIMMED MILK POWDER

PART I

Sampling and analysis of skimmed-milk powder offered for intervention

1. Samples per lot shall be taken in accordance with the procedure laid down in International Standard ISO 707. However, paying agencies may use another method of sampling provided that it complies with the principles of that standard.
2. Number of packages to be selected for taking samples for analysis:
 - (a) lots containing up to 800 25-kg bags: at least eight;
 - (b) lots containing more than 800 25-kg bags: at least eight, plus one for each additional 800 bags or fraction thereof.
3. Weight of sample: samples of at least 200 g are to be taken from each package.
4. Grouping of samples: no more than nine samples are to be combined in a global sample.
5. Analysis of samples: each global sample is to undergo an analysis to verify all the quality characteristics laid down in Part II of Annex V to Delegated Regulation (EU) 2016/1238.
6. Where samples show defects:
 - (a) where a composite sample shows a defect with regard to one parameter, the quantity from which the sample came is rejected;
 - (b) where a composite sample shows a defect with regard to more than one parameter, the quantity from which the sample came is rejected and samples are taken from the remaining quantities from the same plant; the analysis of those samples shall be decisive. In that case:
 - the number of samples laid down in point 2 is doubled,
 - where a composite sample shows a defect with regard to one or more parameters, the quantity from which the sample came is rejected.

]^{F3}PART IA

Methods of analysis of skimmed milk powder for public intervention

Parameter	Method
Protein	ISO 8968 part 1
a	Scorched particles' analyses may be conducted systematically. However, such analyses shall always be conducted if no sensory checks are performed.
b	The method to be applied shall be approved by the paying agency (one or both methods).
c	The method to be applied shall be approved by the paying agency.
d	Sensory checks shall be performed where deemed necessary after risk based analysis approved by the paying agency.

Status: Point in time view as at 07/02/2018.

Changes to legislation: There are currently no known outstanding effects for the Commission Implementing Regulation (EU) 2016/1240. (See end of Document for details)

Fat	ISO 1736
Water	ISO 5537
Acidity	ISO 6091
Lactates	ISO 8069
Phosphatase test	ISO 11816 part 1
Insolubility index	ISO 8156
Scorched particles ^a	ADPI
Micro-organisms	ISO 4833-part 1
Buttermilk	Appendix I
Rennet whey ^b	Appendix II and III
Acid whey ^c	ISO 8069 or On-the-spot inspections
Sensory checks ^d	ISO 22935 part 2 and 3

a Scorched particles' analyses may be conducted systematically. However, such analyses shall always be conducted if no sensory checks are performed.

b The method to be applied shall be approved by the paying agency (one or both methods).

c The method to be applied shall be approved by the paying agency.

d Sensory checks shall be performed where deemed necessary after risk based analysis approved by the paying agency.

Appendix I

SKIMMED MILK POWDER: QUANTITATIVE DETERMINATION OF PHOSPHATIDYLSERINE AND PHOSPHATIDYLETHANOLAMINE

Method: reversed-phase HPLC

1. PURPOSE AND FIELD OF APPLICATION

The method describes a procedure for the quantitative determination of phosphatidylserine (PS) and phosphatidylethanolamine (PE) in skimmed milk powder (SMP) and is suitable for detecting buttermilk solids in SMP.

2. DEFINITION

PS + PE content : the mass fraction of substance determined using the procedure here specified. The result is expressed as milligrams of phosphatidylethanolamine dipalmitoyl (PEDP) per 100 g powder.

3. PRINCIPLE OF THE METHOD

Extraction of aminophospholipids by methanol from reconstituted milk powder. Determination of PS and PE as o-phthalaldehyde (OPA) derivatives by reversed-phase (RP) HPLC and fluorescence detection. Quantification of PS and PE content in the test sample by reference to a standard sample containing a known amount of PEDP.

4. REAGENTS

All reagents shall be of recognised analytical grade. Water shall be distilled or water of at least equivalent purity, unless otherwise specified.

4.1. **Standard material: PEDP, at least 99 % pure**

Status: Point in time view as at 07/02/2018.

Changes to legislation: There are currently no known outstanding effects for the Commission Implementing Regulation (EU) 2016/1240. (See end of Document for details)

Note: Standard material shall be stored at – 18 °C.

4.2. Reagents for standard sample and test sample preparation

4.2.1. *HPLC-grade methanol*

4.2.2. *HPLC-grade chloroform*

4.2.3. *Tryptamine-monohydrochloride*

4.3. Reagents for o-phthaldialdehyde derivatisation

4.3.1. *Sodium hydroxide, 12 M water solution*

4.3.2. *Boric acid, 0,4 M water solution adjusted to pH 10,0 with sodium hydroxide (4.3.1)*

4.3.3. *2-mercaptoethanol*

4.3.4. *o-phthaldialdehyde (OPA)*

4.4. HPLC elution solvents

4.4.1. *Elution solvents shall be prepared using HPLC-grade reagents.*

4.4.2. *HPLC-grade water*

4.4.3. *Methanol of tested fluorimetric purity*

4.4.4. *Tetrahydrofuran*

4.4.5. *Sodium dihydrogen phosphate*

4.4.6. *Sodium acetate*

4.4.7. *Acetic acid.*

5. APPARATUS

5.1. **Analytical balance, capable of weighing to the nearest 1 mg, with a readability of 0,1 mg**

5.2. **Beakers, 25 and 100 ml capacity**

5.3. **Pipettes, capable of delivering 1 and 10 ml**

5.4. **Magnetic stirrer**

5.5. **Graduated pipettes, capable of delivering 0,2, 0,5 and 5 ml**

5.6. **Volumetric flasks, 10, 50 and 100 ml capacity**

5.7. **Syringes, 20 and 100 µl capacity**

5.8. **Ultrasonic bath**

5.9. **Centrifuge, capable of operating at 27 000 × g**

5.10. **Glass vials, about 5 ml capacity**

5.11. **Graduated cylinder, 25 ml capacity**

5.12. **pH-meter, accurate to 0,1 pH units**

Status: Point in time view as at 07/02/2018.

Changes to legislation: There are currently no known outstanding effects for the Commission Implementing Regulation (EU) 2016/1240. (See end of Document for details)

5.13. HPLC equipment

- 5.13.1. *Gradient pumping system, capable of operating at 1,0 ml/min at 200 bar*
- 5.13.2. *Autosampler with derivatisation capability*
- 5.13.3. *Column heater, capable of maintaining the column at 30 °C ± 1 °C*
- 5.13.4. *Fluorescence detector, capable of operating at 330 nm excitation wavelength and 440 nm emission wavelength*
- 5.13.5. *Integrator or data processing software capable of peak area measurement*
- 5.13.6. *A LiChrospher®— 100 column (250 × 4,6 mm) or an equivalent column packed with octadecylsilane (C 18), 5 µm particle size.*

6. SAMPLING

Sampling shall be carried out in accordance with ISO Standard 707.

7. PROCEDURE

7.1. Preparation of the internal standard solution

- 7.1.1. *Weigh 30,0 ± 0,1 mg of tryptamine-monohydrochloride (4.2.3) into a 100 ml volumetric flask (5.6) and make up to the mark with methanol (4.2.1)*
- 7.1.2. *Pipette 1 ml (5.3) of this solution into a 10 ml volumetric flask (5.6) and make up to the mark with methanol (4.2.1) in order to obtain a 0,15 mM tryptamine concentration*

7.2. Preparation of the test sample solution

- 7.2.1. *Weigh 1,000 ± 0,001 g of the SMP sample into a 25 ml beaker (5.2). Add 10 ml of distilled water at 40 °C ± 1 °C by a pipette (5.3) and stir with a magnetic stirrer (5.4) for 30 minutes in order to dissolve any lumps*
- 7.2.2. *Pipette 0,2 ml (5.5) of the reconstituted milk into a 10 ml volumetric flask (5.6), add 100 µl of the 0,15 mM tryptamine solution (7.1) using a syringe (5.7) and make up to the volume with methanol (4.2.1). Mix carefully by inversion and sonicate (5.8) for 15 min*
- 7.2.3. *Centrifuge (5.9) at 27 000 g × g for 10 minutes and collect the supernatant in a glass vial (5.10)*

Note: Test sample solution should be stored at 4 °C until the HPLC analysis is performed.

7.3. Preparation of the external standard solution

- 7.3.1. *Weigh 55,4 mg PEDP (4.1) into a 50 ml volumetric flask (5.6) and add about 25 ml of chloroform (4.2.2) using a graduated cylinder (5.11). Heat the stoppered flask to 50 °C ± 1 °C and mix carefully till the PEDP dissolves. Cool the flask to 20 °C, make up to the volume with methanol (4.2.1) and mix by inversion*
- 7.3.2. *Pipette 1 ml (5.3) of this solution into a 100 ml volumetric flask (5.6) and make up to the volume with methanol (4.2.1). Pipette 1 ml (5.3) of this solution into a 10 ml volumetric flask (5.6), add 100 µl (5.7) of 0,15 mM tryptamine solution (7.1) and make up to the volume with methanol (4.2.1). Mix by inversion*

Note: Reference sample solution should be stored at 4 °C until the HPLC analysis is performed.

Status: Point in time view as at 07/02/2018.

Changes to legislation: There are currently no known outstanding effects for the Commission Implementing Regulation (EU) 2016/1240. (See end of Document for details)

7.4. Preparation of the derivatising reagent

Weigh $25,0 \pm 0,1$ mg of OPA (4.3.4) into a 10 ml volumetric flask (5.6), add 0,5 ml (5.5) of methanol (4.2.1) and mix carefully to dissolve the OPA. Make up to the mark with boric acid solution (4.3.2) and add 20 μ l of 2-mercaptoethanol (4.3.3) by syringe (5.7).

Note: The derivatising reagent should be stored at 4 °C in a brown glass vial and is stable for one week.

7.5. Determination by HPLC

7.5.1. Elution solvents (4.4)

Solvent A: Solution of 0,3 mM sodium dihydrogen phosphate and 3 mM sodium acetate solution (adjusted to pH $6,5 \pm 0,1$ with acetic acid): methanol: tetrahydrofuran = 558:440:2 (v/v/v)

Solvent B: methanol

7.5.2. Suggested eluting gradient:

Time (min)	Solvent A (%)	Solvent B (%)	Flow rate (ml/min)
Initial	40	60	0
0,1	40	60	0,1
5,0	40	60	0,1
6,0	40	60	1,0
6,5	40	60	1,0
9,0	36	64	1,0
10,0	20	80	1,0
11,5	16	84	1,0
12,0	16	84	1,0
16,0	10	90	1,0
19,0	0	100	1,0
20,0	0	100	1,0
21,0	40	60	1,0
29,0	40	60	1,0
30,0	40	60	0

Note: The eluting gradient may require slight modification in order to achieve the resolution shown in figure 1.

Column temperature: 30 °C.

7.5.3. Injection volume: 50 μ l derivatising reagent and 50 μ l sample solution

7.5.4. Column equilibration

Status: Point in time view as at 07/02/2018.

Changes to legislation: There are currently no known outstanding effects for the Commission Implementing Regulation (EU) 2016/1240. (See end of Document for details)

Starting up the system on a daily basis, flush the column with 100 % solvent B for 15 minutes, then set at A:B = 40:60 and equilibrate at 1 ml/min for 15 minutes. Perform a blank run by injecting methanol (4.2.1).

Note: Before long-term storage flush the column with methanol: chloroform = 80:20 (v/v) for 30 minutes.

7.5.5. *Determine the PS + PE content in the test sample*

7.5.6. *Perform the sequence of the chromatographic analyses keeping constant the run-to-run time in order to obtain constant retention times. Inject the external standard solution (7.3) every 5-10 test sample solutions in order to calculate the response factor*

Note: The column shall be cleaned by flushing with 100 % solvent B (7.5.1) for at least 30 minutes every 20-25 runs.

7.6. **Integration mode**

7.6.1. *PEDP peak*

PEDP is eluted as a single peak. Determine the peak area by valley-to- valley integration.

7.6.2. *Tryptamine peak*

Tryptamine is eluted as a single peak (Figure 1). Determine the peak area by valley-to-valley integration.

7.6.3. *PS and PE peaks groups*

Under the described conditions (Figure 1), PS elutes as two main partially unresolved peaks preceded by a minor peak. PE elutes as three main partially unresolved peaks. Determine the whole area of each peak cluster setting the baseline as reported in Figure 1.

8. CALCULATION AND EXPRESSION OF RESULTS

PS and PE content in the test sample shall be calculated as follows:

$$C = 55,36 \times ((A_2)/(A_1)) \times ((T_1)/(T_2))$$

where:

C	= PS or PE content (mg/100 g powder) in the test sample
A ₁	= PEDP peak area of the standard sample solution (7.3)
A ₂	= PS or PE peak area of the test sample solution (7.2)
T ₁	= Tryptamine peak area of the standard sample solution (7.3)
T ₂	= Tryptamine peak area of the test sample solution (7.2).

9. ACCURACY OF THE METHOD

Note: The values for repeatability were calculated according to the IDF International Standard (*).

9.1. **Repeatability**

The relative standard deviation of the repeatability, which expresses the variability of independent analytical results obtained by the same operator using the same apparatus under the same conditions on the same test sample and in a short interval of time, should not exceed 2 % relative. If two determinations are obtained under these conditions, the relative difference between the two results should not be greater than 6 % of the arithmetic mean of the results.

Status: Point in time view as at 07/02/2018.

Changes to legislation: There are currently no known outstanding effects for the Commission Implementing Regulation (EU) 2016/1240. (See end of Document for details)

9.2. Reproducibility

If two determinations are obtained by operators in different laboratories using different apparatus under different conditions for the analysis on the same test sample, the relative difference between the two results should not be greater than 11 % of the arithmetic mean of the results.

10. REFERENCES

- 10.1. Resmini P., Pellegrino L., Hogenboom J.A., Sadini V., Rampilli M., 'Detection of buttermilk solids in skim milk powder by HPLC quantification of aminophospholipids'. *Sci. Tecn. Latt.-Cas.*, 39,395 (1988).

Figure 1 HPLC pattern of OPA-derivatives of phosphatidylserine (PS) and phosphatidylethanolamine (PE) in methanol extract of reconstituted skim-milk powder. Integration mode for the peaks of PS, PE and tryptamine (internal standard) is reported

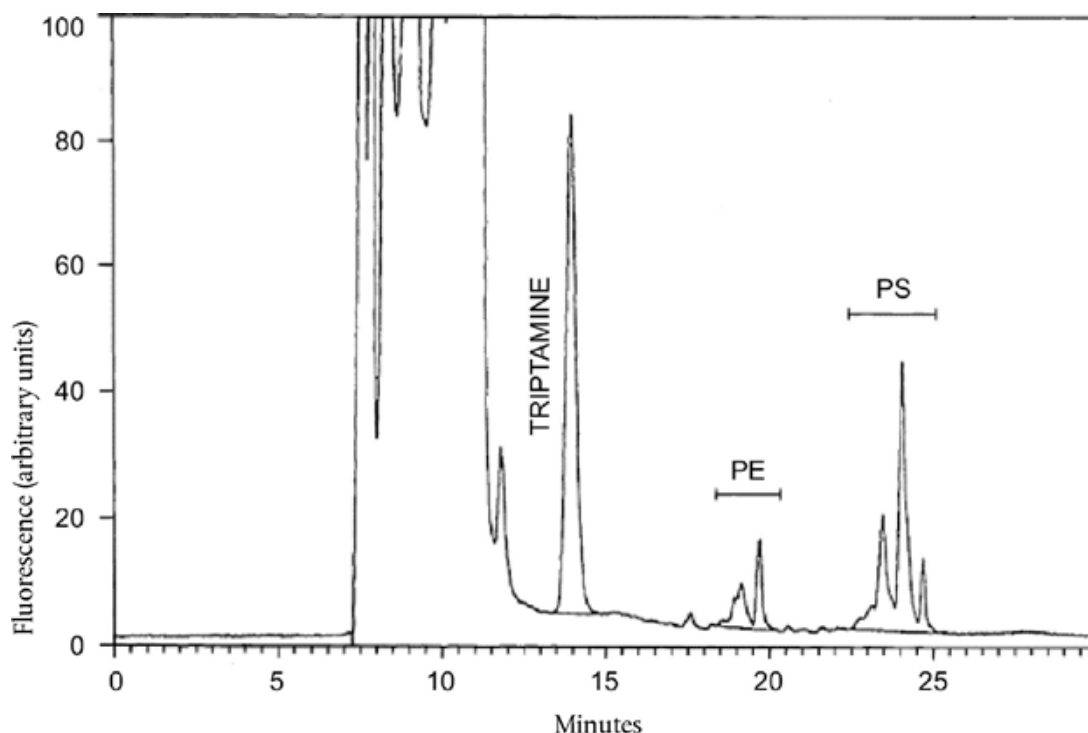

Appendix II

DETECTION OF RENNET WHEY IN SKIMMED MILK POWDER FOR PUBLIC STORAGE BY DETERMINATION OF CASEINOMACROPEPTIDES HIGH-PERFORMANCE LIQUID CHROMATOGRAPHY (HPLC)

1. SCOPE AND FIELD OF APPLICATION

This method allows detection of rennet whey in skimmed milk powder intended for public storage by determination of the caseinomacropeptides.

2. REFERENCE

International Standard ISO 707 - Milk and Milk Products - Guidance on sampling.

3. DEFINITION

Status: Point in time view as at 07/02/2018.

Changes to legislation: There are currently no known outstanding effects for the Commission Implementing Regulation (EU) 2016/1240. (See end of Document for details)

The content of rennet whey solids is defined as the percentage by mass as determined by the caseinomacropptide content by the procedure described.

4. PRINCIPLE

- Reconstitution of the skimmed milk powder, removal of fat and proteins with trichloroacetic acid, followed by centrifugation or filtration;
- Determination of the quantity of caseinomacropptides (CMP) in the supernatant by high-performance liquid chromatography (HPLC);
- Evaluation of the result obtained for the samples by reference to standard samples consisting of skimmed milk powder with or without the addition of a known percentage of whey powder.

5. REAGENTS

All reagents shall be of recognised analytical grade. The water used shall be distilled water or water of at least equivalent purity.

5.1. Trichloroacetic acid solution

Dissolve 240 g of trichloroacetic acid (CCl_3COOH) in water and make up to 1 000 ml. The solution should be clear and colourless.

5.2. Eluent solution, pH 6,0

Dissolve 1,74 g of dipotassium hydrogen phosphate (K_2HPO_4), 12,37 g of potassium dihydrogen phosphate (KH_2PO_4) and 21,41 g of sodium sulphate (Na_2SO_4) in about 700 ml of water. Adjust, if necessary, to pH 6,0, using a solution of phosphoric acid or potassium hydroxide.

Make up to 1 000 ml with water and homogenise.

Note: The composition of the eluent can be updated to comply with the certificate of the standards or the recommendations of the manufacturer of the column packing material.

Filter the eluent solution, prior to use, through a membrane filter with a 0,45 μm pore diameter.

5.3. Flushing solvent

Mix one volume acetonitrile (CH_3CN) with nine volumes water. Filter the mixture prior to use through a membrane filter with a 0,45 μm pore diameter.

Note: Any other flushing solvent with a bactericidal effect which does not impair the columns' resolution efficiency may be used.

5.4. Standard samples

- 5.4.1. *Skimmed milk powder meeting the requirements of this Regulation (i.e. [0])*
- 5.4.2. *The same skimmed milk powder adulterated with 5 % (m/m) rennet-type whey powder of standard composition (i.e. [5])*

6. APPARATUS

6.1. Analytical balance

6.2. Optional centrifuge capable of attaining a centrifugal force of 2 200 g, fitted with stoppered or capped centrifuge tubes of about 50 ml capacity

6.3. Mechanical shaker

Status: Point in time view as at 07/02/2018.

Changes to legislation: There are currently no known outstanding effects for the Commission Implementing Regulation (EU) 2016/1240. (See end of Document for details)

- 6.4. **Magnetic stirrer**
- 6.5. **Glass funnels, diameter about 7 cm**
- 6.6. **Filter papers, medium filtration, diameter about 12,5 cm**
- 6.7. **Glass filtration equipment with 0,45 µm pore diameter membrane filter**
- 6.8. **Graduated pipettes allowing delivery of 10 ml (ISO 648, Class A, or ISO/R 835) or a dispensing system capable of delivering 10,0 ml in two minutes**
- 6.9. **Dispensing system capable of delivering 20,0 ml water at ca. 50 °C**
- 6.10. **Thermostatic water bath, set at 25 ± 0,5 °C**
- 6.11. **HPLC equipment, consisting of:**
 - 6.11.1. *Pump*
 - 6.11.2. *Injector, hand or automatic, with a 15 to 30 µl capacity*
 - 6.11.3. *Two TSK 2 000-SW columns in series (length 30 cm, internal diameter 0,75 cm) or equivalent columns (e.g. single TSK 2 000-SWxl, single Agilent Technologies Zorbax GF 250) and a precolumn (3 cm × 0,3 cm) packed with I 125 or material of equivalent effectiveness*
 - 6.11.4. *Thermostatic column oven, set at 35 ± 1 °C*
 - 6.11.5. *Variable wavelength UV detector, permitting measurements at 205 nm with a sensitivity of 0,008 Å*
 - 6.11.6. *Integrator capable of valley-to-valley integration*

Note: Working with columns kept at room temperature is possible, but their power of resolution is slightly lower. In that case, the temperature should vary by less than ± 5 °C in any one range of analyses.
7. **SAMPLING**
 - 7.1. Samples shall be taken in accordance with the procedure laid down in International Standard ISO 707. However, Member States may use another method of sampling provided that it complies with the principles of the abovementioned standard
 - 7.2. Store the sample in conditions which preclude any deterioration or change in composition
8. **PROCEDURE**
 - 8.1. **Preparation of the test sample**

Transfer the milk powder into a container with a capacity of about twice the volume of the powder, fitted with an airtight lid. Close the container immediately. Mix the milk powder well by means of repeated inversion of the container.
 - 8.2. **Test portion**

Weight 2,000 ± 0,001 g of test sample into a centrifuge tube (6.2) or a suitable stoppered flask (50 ml).
 - 8.3. **Removal of fat and proteins**

Status: Point in time view as at 07/02/2018.

Changes to legislation: There are currently no known outstanding effects for the Commission Implementing Regulation (EU) 2016/1240. (See end of Document for details)

8.3.1. *Add 20,0 ml of warm water (50 °C) to the test portion. Dissolve the powder by shaking for five minutes using a mechanical shaker (6.3). Place the tube into the water bath (6.10) and allow to equilibrate to 25 °C*

8.3.2. *Add 10,0 ml of the trichloroacetic acid solution (5.1) of ca. 25 °C in two minutes, while stirring vigorously with the aid of the magnetic stirrer (6.4). Place the tube in a water bath (6.10) and leave for 60 minutes*

8.3.3. *Centrifuge (6.2) for 10 minutes at 2 200 g, or filter through paper (6.6), discarding the first 5 ml of filtrate*

8.4. **Chromatographic determination**

8.4.1. *Inject 15 to 30 µl of accurately measured supernatant or filtrate (8.3.3) into the HPLC apparatus (6.11) operating at a flow rate of 1,0 ml of eluent solution (5.2) per minute*

Note 1. Another flow rate may be used, dependent of the internal diameter of the columns used or the instructions of the manufacturer of the column.

Note 2. Rinse the columns with water during each interruption. Never leave the eluent solution in them (5.2).

Prior to any interruption of more than 24 hours, rinse the columns with water then wash them with solution (5.3) for at least three hours at a flow rate of 0,2 ml per minute.

8.4.2. *The results of chromatographic analysis of the test sample [E] are obtained in the form of chromatogram in which each peak is identified by its retention time RT as follows:*

Peak II:	The second peak of the chromatogram having an RT of about 12,5 minutes.
Peak III:	The third peak of the chromatogram, corresponding to the CMP, having an RT of 15,5 minutes.

The choice of the column(s) can affect the retention times of the individual peaks considerably.

The integrator (6.11.6) automatically calculates the area A of each peak:

A_{II}:	area of peak II,
A_{III}:	area of peak III,

It is essential to examine the appearance of each chromatogram prior to quantitative interpretation, in order to detect any abnormalities due either to malfunctioning of the apparatus or the columns, or to the origin and nature of the sample analysed.

If in doubt, repeat the analysis.

8.5. **Calibration**

8.5.1. *Apply exactly the procedure described from point 8.2 to point 8.4.2 to the standard samples (5.4)*

Use freshly prepared solutions, because CMP degrade in an 8 % trichloroacetic environment. The loss is estimated at 0,2 % per hour at 30 °C.

Status: Point in time view as at 07/02/2018.

Changes to legislation: There are currently no known outstanding effects for the Commission Implementing Regulation (EU) 2016/1240. (See end of Document for details)

8.5.2. *Prior to chromatographic determination of the samples, condition the columns by repeatedly injecting the standard sample (5.4.2) in solution (8.5.1) until the area and retention time of the peak corresponding to the CMP are constant*

8.5.3. *Determine the response factors R by injecting the same volume of filtrates (8.5.1) as used for the samples*

9. EXPRESSION OF RESULTS

9.1. Method of calculation and formulae

9.1.1. *Calculation of the response factors R:*

Peak II:	$R_{II} = 100/(A_{II}[0])$
----------	----------------------------

where:

R_{II} = the response factors of peaks II,
 $A_{II} [0]$ = the areas of peaks II of the standard sample [0] obtained in 8.5.3.

Peak III:	$R_{III} = W/(A_{III}[5] - A_{III}[0])$
-----------	---

where:

R_{III} = the response factor of peak III,
 $A_{III} [0]$ and $A_{III} [5]$ = the areas of peak III in standard samples [0] and [5] respectively obtained in 8.5.3,
 W = the quantity of whey in standard sample [5], i.e. 5.

9.1.2. *Calculation of the relative area of the peaks in the sample [E]*

$$S_{II}[E] = R_{II} \times A_{II}[E]$$
$$S_{III}[E] = R_{III} \times A_{III}[E]$$
$$S_{IV}[E] = R_{IV} \times A_{IV}[E]$$

where:

$S_{II} [E]$, $S_{III} [E]$, S_{IV} = the relative areas of peaks II, III and IV respectively in the sample [E],
 $A_{II} [E]$, $A_{III} [E]$ = the areas of peaks II and III respectively in the sample [E] obtained in 8.4.2,
 R_{II} , R_{III} = the response factors calculated in 9.1.1.

9.1.3. *Calculation of the relative retention time of peak III in sample [E]:*

$$RRT_{III}[E] = (RT_{III}[E])/(RT_{III}[5])$$

where:

$RRT_{III} [E]$ = the relative retention time of peak III in sample [E],
 $RT_{III} [E]$ = the retention time of peak III in sample [E] obtained in 8.4.2,
 $RT_{III} [5]$ = the retention time of peak III in control sample [5] obtained in 8.5.3.

9.1.4. *Experiments have shown that there is a linear relation between the relative retention time of peak III, i.e. $RRT_{III} [E]$ and the percentage of whey powder added up to 10 %*

Status: Point in time view as at 07/02/2018.

Changes to legislation: There are currently no known outstanding effects for the Commission Implementing Regulation (EU) 2016/1240. (See end of Document for details)

- The RRT_{III} [E] is $< 1,000$ when the whey content is $> 5 \%$;
- The RRT_{III} [E] is $\geq 1,000$ when the whey content is $\leq 5 \%$.

The uncertainty allowed for the values of RRT_{III} is $\pm 0,002$.

Normally the value of RRT_{III} [0] deviates little from 1,034. Depending on the condition of the columns, the value may approach 1,000, but it shall always be greater.

9.2. Calculation of the percentage of rennet whey powder in the sample:

$$W = S_{III}[E] - [1,3 + (S_{III}[0] - 0,9)]$$

where:

- W = the percentage m/m of rennet whey in the sample [E];
- S_{III} [E] = the relative area of peak III of test sample [E] obtained as in 9.1.2;
- 1,3 = represents the relative average area of peak III expressed in grams of rennet whey per 100 g determined in non-adulterated skimmed milk powder of various origins. This figure was obtained experimentally;
- S_{III} [0] = represents the relative area of peak III which is equal to $R_{III} \times A_{III}$ [0]. These values are obtained in 9.1.1 and 8.5.3 respectively;
- $(S_{III} [0] - 0,9)$ = represents the correction to be made to the relative average area 1,3 when S_{III} [0] is not equal to 0,9. Experimentally the relative average area of peak III of the control sample [0] is 0,9.

9.3. Accuracy of the procedure

9.3.1. Repeatability

The difference between the results of two determinations carried out simultaneously or in rapid succession by the same analyst using the same apparatus on identical test material shall not exceed 0,2 % m/m.

9.3.2. Reproducibility

The difference between two single and independent results, obtained in two different laboratories on identical test material shall not exceed 0,4 % m/m.

9.4. Interpretation

- 9.4.1. *Assume the absence of whey if the relative area of peak III, S_{III} [E] expressed in grams of rennet whey per 100 g of the product is $\leq 2,0 + (S_{III}[0] - 0,9)$*

where

2,0	is the maximum value allowed for the relative area of peak III taking into account the relative average area of peak III, i.e. 1,3, the uncertainty due to variations in the composition of skimmed milk powder and the reproducibility of the method (9.3.2),
$(S_{III} [0] - 0,9)$	is the correction to be made when the area S_{III} [0] is different from 0,9 (see point 9.2)

Status: Point in time view as at 07/02/2018.

Changes to legislation: There are currently no known outstanding effects for the Commission Implementing Regulation (EU) 2016/1240. (See end of Document for details)

- 9.4.2. If the relative area of peak III, $S_{III} [E]$ is $> 2,0 + (S_{III}[0] - 0,9)$ and the relative area of peak II, $S_{II} [E] \leq 160$, determine the rennet whey content as indicated in point 9.2.
- 9.4.3. If the relative area of peak III, $S_{III} [E]$ is $> 2,0 + (S_{III}[0] - 0,9)$ and the relative area of peak II, $S_{II} [E] \leq 160$, determine the total protein content (P %); then examine graphs 1 and 2.
- 9.4.3.1. The data obtained after analysis of samples of unadulterated skimmed milk powders with a high total protein content have been assembled in graphs 1 and 2.

The continuous line represents the linear regression, the coefficients of which are calculated by the least squares method.

The dashed straight line fixes the upper limit of the relative area of peak III with a probability of not being exceeded in 90 % of cases.

The equations for the dashed straight lines of graphs 1 and 2 are:

$S_{III} = 0,376 P \% - 10,7$	(graph 1),
$S_{III} = 0,0123 S_{II} [E] + 0,93$	(graph 2),

respectively where:

S_{III}	is the relative area of peak III calculated either according to total protein content or according to the relative area of peak $S_{II} [E]$,
P %	is the total protein content expressed as a percentage, by weight,
$S_{II} [E]$	is the relative area of sample calculated in point 9.1.2.

These equations are equivalent to the figure of 1,3 mentioned in point 9.2.

The discrepancy (T_1 and T_2) between the relative area $S_{III} [E]$ found and the relative area S_{III} is given by means of the following: $T_1 = S_{III}[E] - [(0,376 P\% - 10,7) + (S_{III}[0] - 0,9)]$ $T_2 = S_{III}[E] - [(0,0123 S_{II}[E] + 0,93) + (S_{III}[0] - 0,9)]$

9.4.3.2.	If T_1 and/or T_2	are zero or less, the presence of rennet whey cannot be determined.
	If T_1 and T_2	exceed zero, rennet whey is present.

The rennet whey content is calculated according to the following formula: $W = T_2 + 0,91$

where:

0,91 is the distance on the vertical axis between the continuous and dotted straight lines.

Status: Point in time view as at 07/02/2018.

Changes to legislation: There are currently no known outstanding effects for the Commission Implementing Regulation (EU) 2016/1240. (See end of Document for details)

Skimmed milk powder

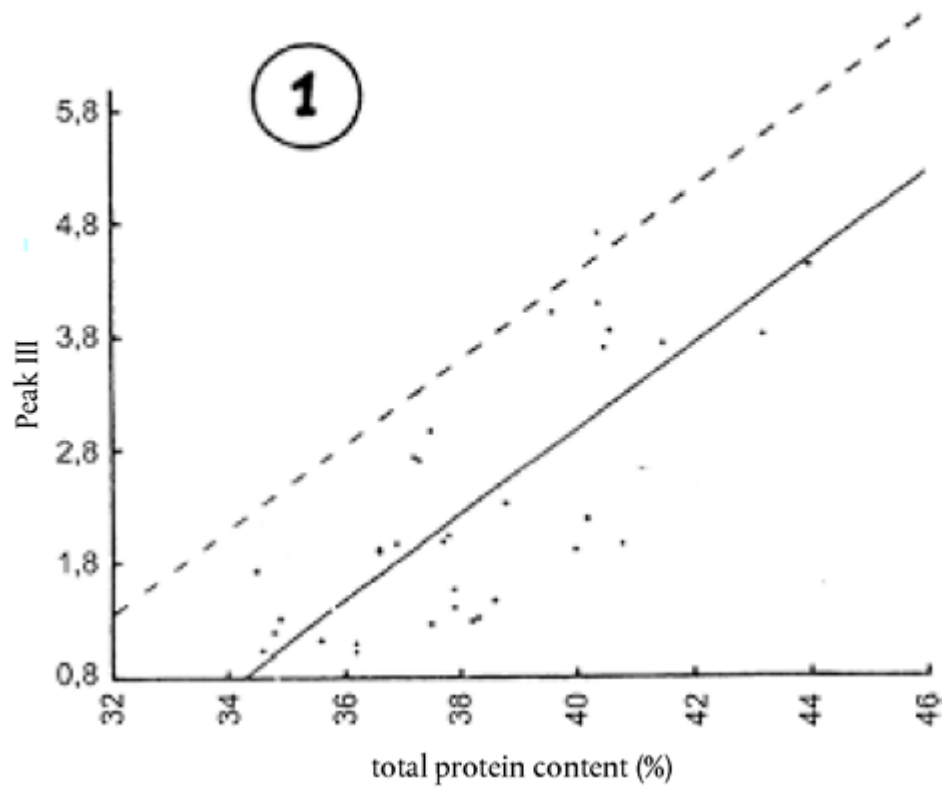

Skimmed milk powder

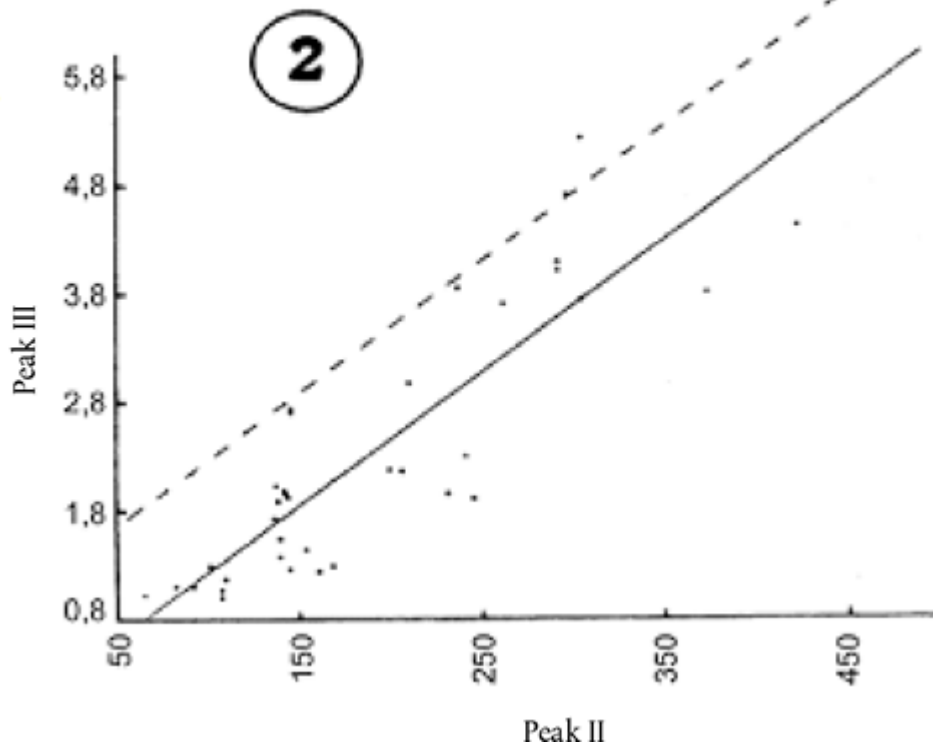

Appendix III

DETERMINING RENNET WHEY SOLIDS IN SKIMMED MILK POWDER

1. PURPOSE: DETECTING THE ADDITION OF RENNET WHEY SOLIDS TO SKIMMED MILK POWDER
2. REFERENCES: INTERNATIONAL STANDARD ISO 707
3. DEFINITION

The content of rennet whey solids is defined as the percentage by mass as determined by caseinomacropptide content by the procedure described.

4. PRINCIPLE

Samples are analysed for caseinomacropptide A by a reversed-phase high-performance liquid chromatography procedure (HPLC procedure). Evaluation of the result is obtained by reference to standard samples consisting of skimmed milk powder with and without a known percentage of whey powder. Results higher than 1 % (m/m) show that rennet whey solids are present.

5. REAGENTS

All reagents shall be of recognised analytical grade. The water used shall be distilled water or water of at least equivalent purity. Acetonitrile should be of spectroscopic or HPLC quality.

- 5.1. **Trichloroacetic acid solution**

Dissolve 240 g of trichloroacetic acid (CCl₃COOH) in water and make up to 1 000 ml. The solution should be clear and colourless.

- 5.2. **Eluents A and B**

Eluent A: 150 ml of acetonitrile (CH₃CN), 20 ml of isopropanol (CH₃CHOHCH₃), and 1,00 ml of trifluoroacetic acid (TFA, CF₃COOH) are placed in a 1 000 ml volumetric flask. Make up to 1 000 ml with water.

Eluent B: 550 ml of acetonitrile, 20 ml of isopropanol and 1,00 ml of TFA are placed in a 1 000 ml volumetric flask. Make up to 1 000 ml with water. Filter the eluent solution, prior to use, through a membrane filter with a 0,45 µm pore diameter.

- 5.3. **Conservation of the column**

After the analyses the column is flushed with eluent B (via a gradient) and subsequently flushed with acetonitrile (via a gradient for 30 minutes). The column is stored in acetonitrile.

- 5.4. **Standard samples**

- 5.4.1. *Skimmed milk powder meeting the requirements for public storage (i.e. [0]).*
 - 5.4.2. *The same skimmed milk powder adulterated with 5 % (m/m) rennet-type whey powder of standard composition (i.e. [5]).*
 - 5.4.3. *The same skimmed milk powder adulterated with 50 % (m/m) rennet-type whey powder of standard composition (i.e. [50]).*

6. APPARATUS

- 6.1. **Analytical balance**

Status: Point in time view as at 07/02/2018.

Changes to legislation: There are currently no known outstanding effects for the Commission Implementing Regulation (EU) 2016/1240. (See end of Document for details)

- 6.2. **Optional centrifuge capable of attaining a centrifugal force of 2 200 g, fitted with stoppered or capped centrifuge tubes of about 50 ml capacity**
- 6.3. **Mechanical shaker**
- 6.4. **Magnetic stirrer**
- 6.5. **Glass funnels, diameter about 7 cm**
- 6.6. **Filter papers, medium filtration, diameter about 12,5 cm**
- 6.7. **Glass filtration equipment with 0,45 µm pore diameter membrane filter**
- 6.8. **Graduated pipettes, allowing delivery of 10 ml (ISO 648, Class A, or ISO/R 835), or a dispensing system capable of delivering 10,0 ml in two minutes**
- 6.9. **Dispensing system capable of delivering 20,0 ml water at ca. 50 °C**
- 6.10. **Thermostatic water bath, set at 25 ± 0,5 °C**
- 6.11. **HPLC equipment, consisting of:**
 - 6.11.1. *Binary gradient pumping system*
 - 6.11.2. *Injector, hand or automatic, with a 100 µl capacity*
 - 6.11.3. *Agilent Technologies Zorbax 300 SB-C3 column (length 25 cm, 0,46 cm internal diameter) or an equivalent wide-pore silica based reversed-phase column*
 - 6.11.4. *Thermostatic column oven, set at 35 ± 1 °C*
 - 6.11.5. *Variable wavelength UV detector, permitting measurements at 210 nm (if necessary, a higher wavelength up to 220 nm may be used) with a sensitivity of 0,02 Å*
 - 6.11.6. *Integrator capable of setting the integration to common baseline or valley-to-valley*

Note: Operation of the column at room temperature is possible, provided that the room temperature does not fluctuate more than 1 °C, otherwise too much variation in the retention time of CMP_A takes place.
7. **SAMPLING**
 - 7.1. **Samples shall be taken in accordance with the procedure laid down in International Standard ISO 707. However, Member States may use another method of sampling provided that it complies with the principles of the abovementioned standard**
 - 7.2. **Store the sample in conditions which preclude any deterioration or change in composition.**
8. **PROCEDURE**
 - 8.1. **Preparation of the test sample**

Transfer the milk powder into a container with a capacity of about twice the volume of the powder, fitted with an airtight lid. Close the container immediately. Mix the milk powder well by means of repeated inversion of the container.
 - 8.2. **Test portion**

Status: Point in time view as at 07/02/2018.

Changes to legislation: There are currently no known outstanding effects for the Commission Implementing Regulation (EU) 2016/1240. (See end of Document for details)

Weigh $2,00 \pm 0,001$ g of test sample into a centrifuge tube (6.2) or suitable stoppered flask (50 ml).

Note: In the case of mixtures, weigh such an amount of the test sample that the defatted sample portion corresponds to 2,00 g.

8.3. Removal of fat and proteins

8.3.1. *Add 20,0 ml of warm water (50 °C) to the test portion. Dissolve the powder by shaking for five minutes using a mechanical shaker (6.3). Place the tube into the water bath (6.10) and allow to equilibrate to 25 °C*

8.3.2. *Add 10,0 ml of the trichloroacetic acid solution of ca. 25 °C (5.1) constantly over two minutes, while stirring vigorously with the aid of the magnetic stirrer (6.4). Place the tube in a water bath (6.10) and leave for 60 minutes*

8.3.3. *Centrifuge (6.2) 2 200 g for 10 minutes, or filter through paper (6.6), discarding the first 5 ml of filtrate*

8.4. Chromatographic determination

8.4.1. *The reversed-phase HPLC method excludes the possibility false-positive results due to the presence of acid buttermilk powder.*

8.4.2. *Before the reversed phase HPLC-analysis is carried out, the gradient conditions should be optimised. A retention time of 26 ± 2 minutes for CMP_A is optimal for gradient systems having a dead volume of about 6 ml (volume from the point where the solvents come together to the volume of the injector loop, inclusive). Gradient systems having a lower dead volume (e.g. 2 ml) should use 22 minutes as an optimal retention time*

Take solutions of the standard samples (5.4) without and with 50 % rennet whey.

Inject 100 µl of supernatant or filtrate (8.3.3) into the HPLC apparatus operating at the scouting gradient conditions given in Table 1.

TABLE 1

Scouting gradient conditions for optimisation of the chromatography

Time(min)	Flow(ml/min)	% A	% B	Curve
Initial	1,0	90	10	*
27	1,0	60	40	linear
32	1,0	10	90	linear
37	1,0	10	90	linear
42	1,0	90	10	linear

Comparison of the two chromatograms should reveal the location of the peak of CMP_A .

Using the formula given below, the initial solvent composition to be used for the normal gradient (see 8.4.3) can be calculated $\% B = 10 - 2,5 + (13,5 + (RT_{cmpA} - 26) / 6) * 30 / 27$ $\% B = 7,5 + (13,5 + (RT_{cmpA} - 26) / 6) * 1,11$

Where:

Status: Point in time view as at 07/02/2018.

Changes to legislation: There are currently no known outstanding effects for the Commission Implementing Regulation (EU) 2016/1240. (See end of Document for details)

RT _{cmpA}	: retention time of CMP _A in the scouting gradient
10	: the initial % B of the scouting gradient
2,5	: % B at midpoint minus % B at initial in the normal gradient
13,5	: midpoint time of the scouting gradient
26	: required retention time of CMP _A
6	: ratio of slopes of the scouting and normal gradient
30	: % B at initial minus % B at 27 minutes in the scouting gradient
27	: run-time of the scouting gradient.

8.4.3. *Take solutions of the test samples*

Inject 100 µl of accurately measured supernatant or filtrate (8.3.3) into the HPLC apparatus operating at a flow rate of 1,0 ml of eluent solution (5.2) per minute.

The composition of the eluent of the start of the analysis is obtained from 8.4.2. It is normally close to A:B = 76:24 (5.2). Immediately after the injection a linear gradient is started, which results in a 5 % higher percentage of B after 27 minutes. Subsequently a linear gradient is started, which brings the eluent composition to 90 % B in five minutes. This composition is maintained for five minutes, after which the composition is changed, via a linear gradient in five minutes to the initial composition. Depending on the internal volume of the pumping system, the next injection can be made 15 minutes after reaching the initial conditions.

Note 1. The retention time of the CMP_A should be 26 ± 2 minutes. This can be achieved by varying the initial and end conditions of the first gradient. However, the difference in the % B for the initial and end conditions of the first gradient shall remain 5 % B.

Note 2. The eluents should be degassed sufficiently and should also remain degassed. This is essential for proper functioning of the gradient pumping system. The standard deviation for the retention time of the CMP_A peak should be smaller than 0,1 minutes (n = 10).

Note 3. Every five samples the reference sample [5] should be injected and used to calculate a new response factor R. (9.1.1).

8.4.4. *The results of the chromatographic analysis of the test sample (E) are obtained in the form of a chromatogram in which the CMP_A peak is identified by its retention time of about 26 minutes*

The integrator (6.11.6) automatically calculates the peak height H of the CMP_A peak. The baseline location should be checked in every chromatogram. The analysis or the integration should be repeated if the baseline was incorrectly located.

Note: If the CMP_A peak is sufficiently separated from other peaks valley-to-valley baseline allocation should be used, otherwise use dropping perpendiculars to a common baseline, which should have starting point close to the CMP_A peak (thus not at t = 0 min!). Use for the standard and the samples the same type integration type and check in case of common baseline its consistency for the samples and the standard.

It is essential to examine the appearance of each chromatogram prior to quantitative interpretation, in order to detect any abnormalities due either to malfunctioning of the apparatus or the column, or to the origin and nature of the sample analysed. If in doubt, repeat the analysis.

8.5. **Calibration**

8.5.1. *Apply exactly the procedure described from point 8.2 to point 8.4.4 to the standard samples (5.4.1 to 5.4.2). Use freshly prepared solutions, because CMP degrades in an 8 % trichloroacetic acid environment at room temperature. At 4 °C the solution*

Status: Point in time view as at 07/02/2018.

Changes to legislation: There are currently no known outstanding effects for the Commission Implementing Regulation (EU) 2016/1240. (See end of Document for details)

remains stable for 24 hours. In the case of long series of analyses the use of a cooled sample tray in the automatic injector is desirable

Note: 8.4.2. may be omitted if the % B at initial conditions is known from previous analyses.

The chromatogram of the reference sample [5] should be analogous to Figure. 1. In this figure the CMP_A peak is preceded by two small peaks. It is essential to obtain a similar separation.

8.5.2. *Prior to chromatographic determination of the samples inject 100 µl of the standard sample without rennet whey [0] (5.4.1)*

The chromatogram should not show a peak at the retention time of the CMP_A peak.

8.5.3. *Determine the response factors R by injecting the same volume of filtrate (8.5.1) as used for the samples.*

9. EXPRESSION OF RESULTS

9.1. Method of calculation and formulae

9.1.1. *Calculation of the response factor R:*

CMP_A peak: $R = W/H$

Where:

R = the response factor of the CMP_A peak
H = the height of the CMP_A peak
W = the quantity of whey in the standard sample [5].

9.2. Calculation of the percentage of rennet whey powder in the sample

$W(E) = R \times H(E)$

Where:

W(E) = the percentage (m/m) of rennet whey in the sample (E).
R = the response factor of the CMP_A peak (9.1.1)
H(E) = the height of the CMP_A peak of the sample (E)

If W(E) is greater than 1 % and the difference between the retention time and that of the standard sample [5] is smaller than 0,2 minutes then rennet whey solids are present.

9.3. Accuracy of the procedure

9.3.1. *Repeatability*

The difference between the results of two determinations carried out simultaneously or in rapid succession by the same analyst using the same apparatus on identical test material shall not exceed 0,2 % m/m.

9.3.2. *Reproducibility*

Not determined.

9.3.3. *Linearity*

From 0 to 16 % of rennet whey a linear relationship should be obtained with a coefficient of correlation > 0,99.

9.4. Interpretation

Status: Point in time view as at 07/02/2018.

Changes to legislation: There are currently no known outstanding effects for the Commission Implementing Regulation (EU) 2016/1240. (See end of Document for details)

The 1 % limit includes the uncertainty due to reproducibility.

Figure 1 Ni—4.6 standard

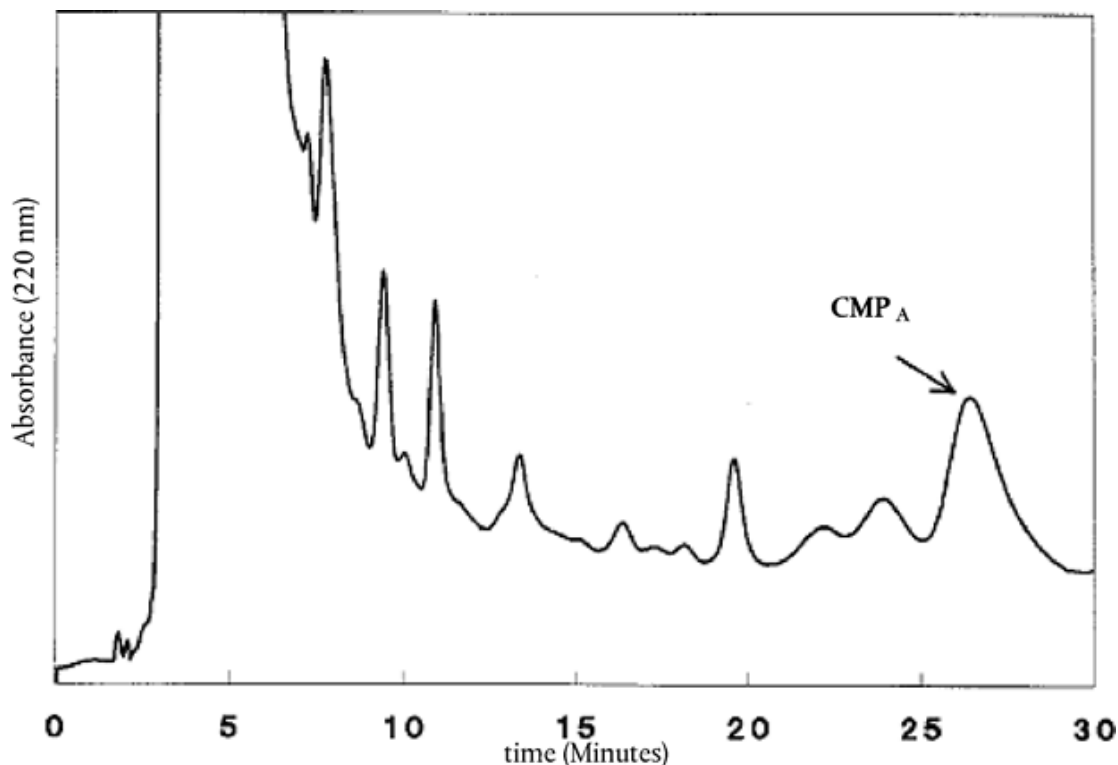

- (*) International IDF Standard 135B/1991. Milk and milk products. Precision characteristics of analytical methods. Outline of collaborative study procedure.]

PART II

Delivery and packaging of skimmed milk powder

1. Skimmed milk powder shall be packed in new, clean, dry and intact bags meeting the following requirements:
 - (a) the bags shall have at least three layers, which together correspond to at least 420 J/m² TEA average;
 - (b) the second layer shall be covered with a layer of polyethylene of at least 15 g/m²;
 - (c) inside the paper layers, a polyethylene bag at least 0,08 mm thick shall be fused to the bottom;
 - (d) bags shall conform to standard EN 770;
 - (e) when filling, the powder should be well pressed down. Loose powder must on no account be allowed to penetrate between the various layers.
2. The bags shall show the following particulars, where appropriate in code:
 - (a) the approval number identifying the factory and the Member State of production;

Status: Point in time view as at 07/02/2018.

Changes to legislation: There are currently no known outstanding effects for the Commission Implementing Regulation (EU) 2016/1240. (See end of Document for details)

- (b) the date or, where appropriate, the week of production;
 - (c) the number of the production batch;
 - (d) the description 'spray skimmed-milk powder'.
3. The storekeeper shall keep a register in which the particulars referred to in point 2 are recorded on the date of entry into storage.

[^{F3}ANNEX VI

Methods of analysis of butter under private storage

Parameter	Method
Fat ^a	ISO 17189 or ISO 3727 part 3
Water	ISO 3727 part 1
Non Fat Solids (excluding salt)	ISO 3727 part 2
Salt	ISO 15648

^a The method to be applied shall be approved by the paying agency.

ANNEX VII

Methods of analysis of skimmed milk powder under private storage

Parameter	Method
Fat	ISO 1736
Protein	ISO 8968 part 1
Water	ISO 5537

ANNEX VIII

Methods of analysis of cheeses under private storage

1. The method of analysis laid down in the Appendix shall be used to ensure that cheese made exclusively from ewe's milk, goat's milk or buffalo milk or from a mixture of ewe's milk, goat's milk and buffalo milk does not contain cow's milk casein.

Cow's milk casein is considered to be present if the cow's milk casein content of the analysed sample is equal to or higher than the content of the reference sample containing 1 % cow's milk as laid down in the Appendix.

2. Methods for detecting cow's milk casein in cheeses referred to in paragraph 1 may be used provided that:
 - (a) the detection limit is maximum 0,5 % and

Status: Point in time view as at 07/02/2018.

Changes to legislation: There are currently no known outstanding effects for the Commission Implementing Regulation (EU) 2016/1240. (See end of Document for details)

- (b) there are no false-positive results and
- (c) cow's milk casein is detectable with the required sensitivity even after long ripening periods, as may occur in usual commercial conditions.

If any of the above mentioned requirements is not met, the methods laid down in the Appendix shall be used.

Appendix

METHOD FOR THE DETECTION OF COW'S MILK AND CASEINATE IN CHEESES FROM EWE'S MILK, GOAT'S MILK OR BUFFALO MILK OR MIXTURES OF EWE'S MILK, GOAT'S MILK AND BUFFALO MILK

1. SCOPE

Detection of cow's milk and caseinate in cheeses made from ewe's milk, goat's milk, buffalo milk or mixtures of ewe's, goat's and buffalo milk by isoelectric focusing of γ -caseins after plasminolysis.

2. FIELD OF APPLICATION

The method is suitable for sensitive and specific detection of native and heat-treated cow's milk and caseinate in fresh and ripened cheeses made from ewe's milk, goat's milk, buffalo milk or mixtures of ewe's, goat's and buffalo milk. It is not suitable for the detection of milk and cheese adulteration by heat-treated bovine whey protein concentrates.

3. PRINCIPLE OF THE METHOD

- 3.1. **Isolation of caseins from cheese and the reference standards**
- 3.2. **Dissolving of the isolated caseins and submitting to plasmin (EC.3.4.21.7) cleavage**
- 3.3. **Isoelectric focusing of plasmin-treated caseins in the presence of urea and staining of proteins**
- 3.4. **Evaluation of stained γ_3 and γ_2 -casein patterns (evidence of cow's milk) by comparison of the pattern obtained from the sample with those obtained in the same gel from the reference standards containing 0 % and 1 % cow's milk.**

4. REAGENTS

Unless otherwise indicated, analytical grade chemicals shall be used. Water shall be double-distilled or of equivalent purity.

Note: The following details apply to laboratory prepared polyacrylamide gels containing urea, of dimensions $265 \times 125 \times 0,25$ mm. Where other sizes and types of gel are used, the separation conditions may have to be adjusted.

Isoelectric focusing

4.1. **Reagents for production of the urea containing polyacrylamide gels**

4.1.1. *Stock gel solution*

Dissolve:

- 4,85 g acrylamide
- 0,15 g N, N'-methylene-bis-acrylamide (BIS)

Status: Point in time view as at 07/02/2018.

*Changes to legislation: There are currently no known outstanding effects for the
Commission Implementing Regulation (EU) 2016/1240. (See end of Document for details)*

48,05 g urea
15,00 g glycerol (87 % w/w),

in water and make up to 100 ml and store in a brown glass bottle in the refrigerator.

Note: A commercially available pre-blended acrylamide/BIS solution may be used in preference to the quoted fixed weights of the neurotoxic acrylamides. Where such a solution contains 30 % w/v acrylamide and 0,8 % w/v BIS, a volume of 16,2 ml shall be used for the formulation instead of the fixed weights. The shelf life of the stock solution is a maximum of 10 days; if its conductivity is more than 5 μ S, de-ionize by stirring with 2 g Amberlite MB-3 for 30 minutes, then filter through a 0,45 μ m membrane.

4.1.2. *Gel solution*

Prepare a gel solution by mixing additives and ampholytes (*) with the stock gel solution (see 4.1.1).

9,0 ml stock solution
24 mg β -alanine
500 μ l ampholyte pH 3,5-9,5
250 μ l ampholyte pH 5-7
250 μ l ampholyte pH 6-8

Mix the gel solution and de-gas for two to three minutes in an ultrasonic bath or in vacuum.

Note: Prepare the gel solution immediately prior to pouring it (see 6.2).

4.1.3. *Catalyst solutions*

4.1.3.1. N, N, N' N' — tetramethylethylenediamine (Temed)

4.1.3.2. 40 % w/v ammonium persulphate (PER):

Dissolve 800 mg PER in water and make up to 2 ml.

Note: Always use freshly prepared PER solution.

4.2. **Contact fluid**

Kerosene or liquid paraffin

4.3. **Anode solution**

Dissolve 5,77 g phosphoric acid (85 % w/w) in water and dilute to 100 ml.

4.4. **Cathode solution**

Dissolve 2,00 g sodium hydroxide in water and dilute to 100 ml with water.

Sample preparation

4.5. **Reagents for protein isolation**

4.5.1. *Dilute acetic acid (25,0 ml of glacial acetic acid made up to 100 ml with water)*

4.5.2. *Dichloromethane*

4.5.3. *Acetone*

4.6. **Protein dissolving buffer**

Status: Point in time view as at 07/02/2018.

Changes to legislation: There are currently no known outstanding effects for the Commission Implementing Regulation (EU) 2016/1240. (See end of Document for details)

Dissolve

5,75 g glycerol (87 % w/w)
24,03 g urea
250 mg dithiothreitol,

in water and make up to 50 ml

Note: Store in a refrigerator, maximum shelf-life one week.

4.7. Reagents for plasmin cleavage of caseins

4.7.1. Ammonium carbonate buffer

Titrate a 0,2 mol/l ammonium hydrogencarbonate solution (1,58 g/100 ml water) containing 0,05 mol/l ethylenediaminetetraacetic acid (EDTA, 1,46 g/100 ml with a 0,2 mol/l ammonium carbonate solution (1,92 g/100 ml water) containing 0,05 mol/l EDTA to pH 8.

4.7.2. Bovine plasmin (EC. 3.4.21.7), activity at least 5 U/ml

4.7.3. ϵ -Aminocaproic acid solution for enzyme inhibition

Dissolve 2,624 g ϵ -aminocaproic acid (6 amino-n-hexanoic acid) in 100 ml of 40 % (v/v) ethanol.

4.8. Standards

4.8.1. *Certified reference standards of a mixture of renneted ewe's and goat's skimmed milk containing 0 % and 1 % of cow's milk are available from the Commission's Institute for Reference Materials and Measurements, B-2440 Geel, Belgium*

4.8.2. *Preparation of laboratory interim-standards of buffalo's renneted milk containing 0 % and 1 % of cow's milk*

Skimmed milk is prepared by centrifuging of either buffalo or bovine raw bulk milk at 37 °C at 2 500 g for 20 minutes. After cooling the tube and contents rapidly to 6 to 8 °C, the upper fat layer is removed completely. For the preparation of the 1 % standard add 5,00 ml of bovine skimmed milk to a 495 ml of buffalo's skimmed milk in a 1 l beaker, adjust the pH to 6,4 by the addition of dilute lactic acid (10 % w/v). Adjust the temperature to 35 °C and add 100 μ l of calf rennet (rennet activity 1: 10 000, c. 3 000 U/ml), stir for 1 minute and then leave the beaker covered with an aluminium foil at 35 °C for one hour to allow formation of the curd. After the curd has formed, the whole renneted milk is freeze-dried without prior homogenization or draining of the whey. After freeze-drying it is finely ground to produce a homogeneous powder. For the preparation of the 0 % standard, carry out the same procedure using genuine buffalo skimmed milk. The standards shall be stored at – 20 °C.

Note: It is advisable to check the purity of the buffalo milk by isoelectric focusing of the plasmin-treated caseins before preparation of the standards.

Reagents for protein staining

4.9. Fixative

Dissolve 150 g trichloroacetic acid in water and make up to 1 000 ml.

4.10. Destaining solution

Dilute 500 ml methanol and 200 ml glacial acetic acid to 2 000 ml with distilled water.

Status: Point in time view as at 07/02/2018.

Changes to legislation: There are currently no known outstanding effects for the Commission Implementing Regulation (EU) 2016/1240. (See end of Document for details)

Note: Prepare the destaining solution fresh every day; it can be prepared by mixing equal volumes of stock solutions of 50 % (v/v) methanol and 20 % (v/v) glacial acetic acid.

4.11. Staining solutions

4.11.1. Staining solution (stock solution 1)

Dissolve 3,0 g Coomassie Brilliant Blue G-250 (C.I. 42655) in 1 000 ml 90 % (v/v) methanol using a magnetic stirrer (approximately 45 minutes), filter through two medium-speed folded filters.

4.11.2. Staining solution (stock solution 2)

Dissolve 5,0 g copper sulphate pentahydrate in 1 000 ml 20 % (v/v) acetic acid.

4.11.3. Staining solution (working solution)

Mix together 125 ml of each of the stock solutions (4.11.1, 4.11.2) immediately prior to staining.

Note: The staining solution should be prepared on the day that it is used.

5. EQUIPMENT

5.1. **Glass plates (265 × 125 × 4 mm); rubber roller (width 15 cm); levelling table**

5.2. **Gel carrier sheet (265 × 125 mm)**

5.3. **Covering sheet (280 × 125 mm). Stick on strip of adhesive tape (280 × 6 × 0,25 mm) to each long edge (see Figure 1)**

5.4. **Electrofocusing chamber with cooling plate (e.g. 265 × 125 mm) and suitable power supply (≥ 2,5 kV) or automatic electrophoresis device**

5.5. **Circulation cryostat, thermostatically controlled at 12 ± 0,5 °C**

5.6. **Centrifuge, adjustable to 3 000 g**

5.7. **Electrode strips (≥ 265 mm long)**

5.8. **Plastic dropping bottles for the anode and cathode solutions**

5.9. **Sample applicators (10 × 5 mm, viscose or low protein-adsorption filter paper)**

5.10. **Stainless steel or glass staining and destaining dishes (e.g. 280 × 150 mm instrument trays)**

5.12. **Adjustable rod homogenizer (10 mm shaft diameter), rpm range 8 000 to 20 000**

5.13. **Magnetic stirrer**

5.14. **Ultrasonic bath**

5.15. **Film welder**

5.16. **25 µl micropipettes**

5.17. **Vacuum concentrator or freeze-dryer**

5.18. **Thermostatically controlled water bath adjustable to 35 and 40 ± 1 °C with shaker**

5.19. **Densitometer equipment reading at $\lambda = 634$ nm**

Status: Point in time view as at 07/02/2018.

Changes to legislation: There are currently no known outstanding effects for the Commission Implementing Regulation (EU) 2016/1240. (See end of Document for details)

6. PROCEDURE

6.1. Sample preparation

6.1.1. Isolation of caseins

Weigh the amount equivalent to 5 g dry mass of cheese or the reference standards into a 100 ml centrifuge tube, add 60 ml distilled water and homogenize with a rod homogenizer (8 000 to 10 000 rpm). Adjust to pH 4,6 with dil. acetic acid (4.5.1) and centrifuge (5 minutes, 3 000 g). Decant the fat and whey, homogenize the residue at 20 000 rpm in 40 ml distilled water adjusted to pH 4,5 with dil. acetic acid (4.5.1), add 20 ml dichloromethane (4.5.2), homogenize again and centrifuge (5 minutes, 3 000 g). Remove the casein layer that lies between the aqueous and organic phases (see Figure 2) with a spatula and decant off both phases. Rehomogenise the casein in 40 ml distilled water (see above) and 20 ml dichloromethane (4.5.2) and centrifuge. Repeat this procedure until both extraction phases are colourless (two to three times). Homogenize the protein residue with 50 ml acetone (4.5.3) and filter through a medium-speed folded filter paper. Wash the residue on the filter with two separate 25 ml portions of acetone each time and allow to dry in the air or a stream of nitrogen, then pulverize finely in a mortar.

Note: Dry casein isolates should be kept at $-20\text{ }^{\circ}\text{C}$.

6.1.2. Plasmin cleavage of β -caseins to intensify γ -caseins

Disperse 25 mg of isolated caseins (6.1.1) in 0,5 ml ammonium carbonate buffer (4.7.1) and homogenize for 20 minutes by e.g. using ultrasonic treatment. Heat to $40\text{ }^{\circ}\text{C}$ and add 10 μl plasmin (4.7.2), mix and incubate for one hour at $40\text{ }^{\circ}\text{C}$ with continuous shaking. To inhibit the enzyme add 20 μl ϵ -aminopropionic acid solution (4.7.3), then add 200 mg of solid urea and 2 mg of dithiothreitol.

Note: To obtain more symmetry in the focused casein bands it is advisable to freeze-dry the solution after adding the ϵ -aminocaproic acid and then dissolving the residues in 0,5 ml protein dissolving buffer (4.6).

6.2. Preparation of the urea containing polyacrylamide gels

With the aid of a few drops of water roll the gel carrier sheet (5.2) onto a glass plate (5.1), removing any extraneous water with paper towel or tissue. Roll the cover sheet (5.3) with spacers (0,25 mm) onto another glass plate in the same way. Lay the plate horizontally on a levelling table.

Add 10 μl Temed (4.1.3.1) to the prepared and de-aerated gel solution (4.1.2), stir and add 10 μl PER-solution (4.1.3.2), mix thoroughly and immediately pour out evenly onto the centre of the cover sheet. Place one edge of the gel carrier plate (sheet side down) on the cover sheet plate and lower it slowly so that a gel film forms between the sheets and spreads out regularly and free of bubbles (Figure 3). Carefully lower the gel carrier plate completely using a thin spatula and place three more glass plates on top of it to act as weights. After polymerization is complete (about 60 minutes) remove the gel polymerized onto the gel carrier sheet along with the cover sheet by tipping the glass plates. Clean the reverse of the carrier sheet carefully to remove gel residues and urea. Weld the gel sandwich into a film tube and store in a refrigerator (maximum six weeks).

Note: The cover sheet with the spacers can be re-used. The polyacrylamide gel can be cut to smaller sizes, recommended when there are few samples or if an automatic electrophoresis device is used (two gels, size $4,5 \times 5\text{ cm}$).

Status: Point in time view as at 07/02/2018.

Changes to legislation: There are currently no known outstanding effects for the Commission Implementing Regulation (EU) 2016/1240. (See end of Document for details)

6.3. Isoelectric focusing

Set the cooling thermostat to 12 °C. Wipe off the reverse of the gel carrier sheet with kerosene, then drip a few drops of kerosene (4.2) onto the centre of the cooling block. Then roll the gel sandwich, carrier side down, onto it, taking care to avoid bubbles. Wipe off any excess kerosene and remove the cover sheet. Soak the electrode strips with the electrode solutions (4.3, 4.4), cut to gel length and place in the positions provided (distance of electrodes 9,5 cm).

Conditions for isoelectric focusing:

6.3.1. Gel size 265 × 125 × 0,25 mm

Step	Time(min.)	Voltage(V)	Current(mA)	Power(W)	Volt-hours(Vh)
1. Pre-focusing	30	maximum 2 500	maximum 15	constant 4	c. 300
2. Sample focusing ^a	60	maximum 2 500	maximum 15	constant 4	c. 1 000
3. Final focusing	60	maximum 2 500	maximum 5	maximum 20	c. 3 000
	40	maximum 2 500	maximum 6	maximum 20	c. 3 000
	30	maximum 2 500	maximum 7	maximum 25	c. 3 000

^a Sample application: After pre-focusing (step 1), pipette 18 µl of the sample and standard solutions onto the sample applicators (10 × 5 mm), place them on the gel at 1 mm intervals from each other and 5 mm longitudinally from the anode and press lightly. Carry out focusing using the above conditions, carefully removing the sample applicators after the 60 minutes of sample focusing.

Note: If thickness or width of the gels are changed, the values for current and power have to be suitably adjusted (e.g. double the values for electric current and power if a 265 × 125 × 0,5 mm gel is used).

6.3.2. Example of a voltage programme for an automatic electrophoresis device (2 gels of 5,0 × 4,5 cm), electrodes without strips applied directly to the gel

Step	Voltage	Current	Power	Temp.	Volt-hours
1. Pre-focusing	1 000 V	10,0 mA	3,5 W	8 °C	85 Vh
2. Sample focusing	250 V	5,0 mA	2,5 W	8 °C	30 Vh
3. Focusing	1 200 V	10,0 mA	3,5 W	8 °C	80 Vh
4. Focusing	1 500 V	5,0 mA	7,0 W	8 °C	570 Vh

Place sample applicator in step 2 at 0 Vh.

Status: Point in time view as at 07/02/2018.

Changes to legislation: There are currently no known outstanding effects for the Commission Implementing Regulation (EU) 2016/1240. (See end of Document for details)

Remove sample applicator in step 2 at 30 Vh.

6.4. Protein staining

6.4.1. Protein fixation

Remove the electrode strips immediately after turning off the power and put the gel immediately into a staining/destaining dish filled with 200 ml fixative (4.9); leave for 15 minutes, shaking continuously.

6.4.2. Washing and staining the gel plate

Thoroughly drain off the fixative and wash the gel plate twice for 30 seconds each time with 100 ml destaining solution (4.10). Pour off the destaining solution and fill the dish with 250 ml staining solution (4.11.3); allow to stain for 45 minutes with gentle shaking.

6.4.3. Destaining the gel plate

Pour off the staining solution, wash the gel plate twice using a 100 ml destaining solution (4.10) each time, then shake with 200 ml destaining solution for 15 minutes and repeat the destaining step at least two or three times until the background is clear and uncoloured. Then rinse the gel plate with distilled water (2 × 2 minutes) and dry in the air (2 to 3 hours) or with a hairdryer (10 to 15 minutes).

Note 1: Carry out fixing, washing, staining and destaining at 20 °C. Do not use elevated temperatures.

Note 2: If more sensitive silver staining (e.g. Silver Staining Kit, Protein, Pharmacia Biotech, Code No 17-1150-01) is preferred, plasmin-treated casein samples have to be diluted to 5 mg/ml.

7. EVALUATION

Evaluation is performed by comparing the protein patterns of the unknown sample with reference standards on the same gel. Detection of cow's milk in cheeses from ewe's milk, goat's milk and buffalo milk and mixtures of ewe's, goat's and buffalo milk is done via the γ_3 - and γ_2 -caseins, whose isoelectric points range between pH 6,5 and pH 7,5 (Figures 4 a, b, Figure 5). The detection limit is less than 0,5 %.

7.1. Visual estimation

For visual evaluation of the amount of bovine milk it is advisable to adjust the concentrations of samples and standards to obtain the same level of intensity of the ovine, caprine and/or buffalo γ_2 - and γ_3 -caseins (see ' γ_2 E,G,B' and ' γ_3 E,G,B' in Figures 4 a, b and Figure 5). After which the amount of bovine milk (less than, equal to or greater than 1 %) in the unknown sample can be judged directly by comparing the intensity of the bovine γ_3 - and γ_2 -caseins (see ' γ_3 C' and ' γ_2 C' in Figures 4 a, b and Figure 5) to those of the 0 % and 1 % reference standards (ewe, goat) or, laboratory interim-standards (buffalo).

7.2. Densitometric estimation

If available, apply densitometry (5.19) for the determination of the peak area ratio of bovine to ovine, caprine and/or buffalo γ_2 - and γ_3 -caseins (see Figure 5). Compare this value to γ_2 - and γ_3 -casein peak area ratio of the 1 % reference standard (ewe, goat) or laboratory interim-standard (buffalo) analysed on the same gel.

Note: The method is operating satisfactorily, if there is a clear positive signal for both bovine γ_2 - and γ_3 -caseins in the 1 % reference standard but not in the 0 % reference standard. If not, optimize the procedure following the details of the method precisely.

Status: Point in time view as at 07/02/2018.

Changes to legislation: There are currently no known outstanding effects for the
Commission Implementing Regulation (EU) 2016/1240. (See end of Document for details)

A sample is judged as being positive, if both bovine γ_2 - and γ_3 -caseins or the corresponding peak area ratios are equal to or greater than the level of the 1 % reference standard.

8. REFERENCES

Addeo F., Moio L., Chianese L., Stingo C., Resmini P., Berner I., Krause I., Di Luccia A., Bocca A.: Use of plasmin to increase the sensitivity of the detection of bovine milk in ovine and/or caprine cheese by gel isoelectric focusing of γ_2 -caseins. *Milchwissenschaft* 45, 708-711 (1990).

Addeo F., Nicolai M.A., Chianese L., Moio L., Spagna Musso S., Bocca A., Del Giovine L.: A control method to detect bovine milk in ewe and water buffalo cheese using immunoblotting. *Milchwissenschaft* 50, 83-85 (1995).

Krause I., Berner I., Klostermeyer H.: Sensitive detection of cow milk in ewe and goat milk and cheese by carrier ampholyte — and carrier ampholyte/immobilized pH gradient — isoelectric focusing of γ -caseins using plasmin as signal amplifier. in: *Electrophoresis-Forum 89* (B. J. Radola, ed.) pp 389-393, Bode-Verlag, München (1989).

Krause I., Belitz H.-D., Kaiser K.-P.: Nachweis von Kuhmilch in Schaf and Ziegenmilch bzw. -käse durch isoelektrische Fokussierung in harnstoffhaltigen Polyacrylamidgelen. *Z. Lebensm. Unters. Forsch.* 174, 195-199 (1982).

Radola B.J.: Ultrathin-layer isoelectric focusing in 50-100 μm polyacrylamide gels on silanised glass plates or polyester films. *Electrophoresis* 1, 43-56 (1980).

Figure 1 Schematic drawing of the covering sheet

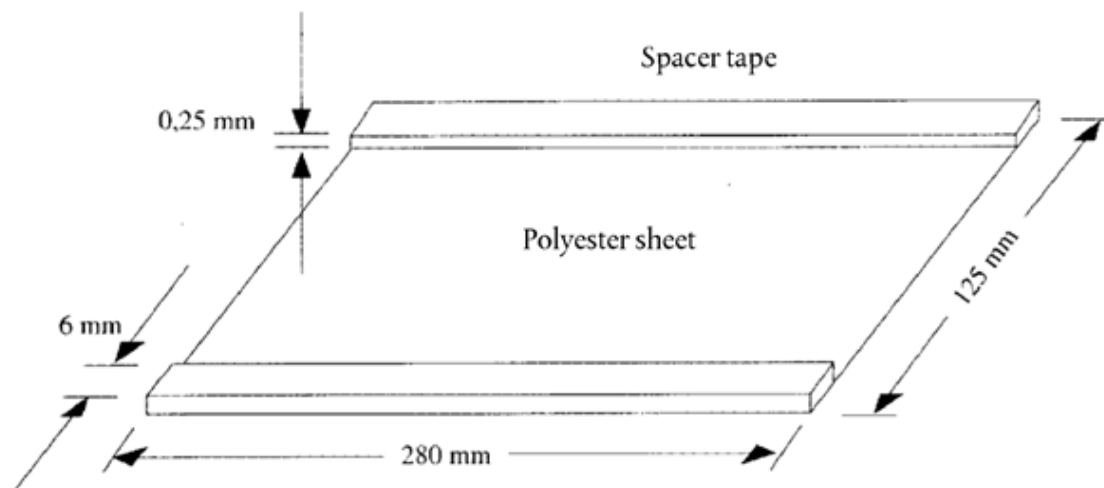

Figure 2 Casein layer floating between aqueous and organic phases after centrifugation

Status: Point in time view as at 07/02/2018.

Changes to legislation: There are currently no known outstanding effects for the Commission Implementing Regulation (EU) 2016/1240. (See end of Document for details)

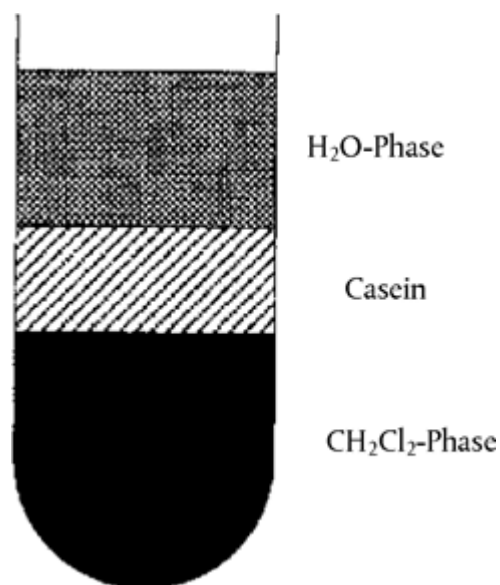
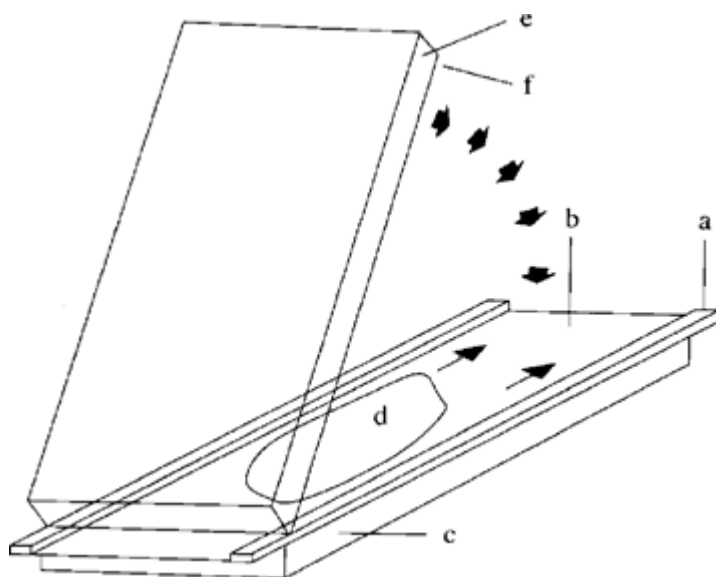

Figure 3 Flapping technique for casting of ultrathin polyacrylamide gels



a = spacer tape (0,25 mm); b = covering sheet (5.3); c, e = glass plates (5.1); d = gel solution (4.1.2); f = gel carrier sheet (5.2)

Figure 4a Isoelectric focusing of plasmin-treated caseins from ewe's and goat's milk cheese containing different amounts of cow's milk.

Status: Point in time view as at 07/02/2018.

Changes to legislation: There are currently no known outstanding effects for the Commission Implementing Regulation (EU) 2016/1240. (See end of Document for details)

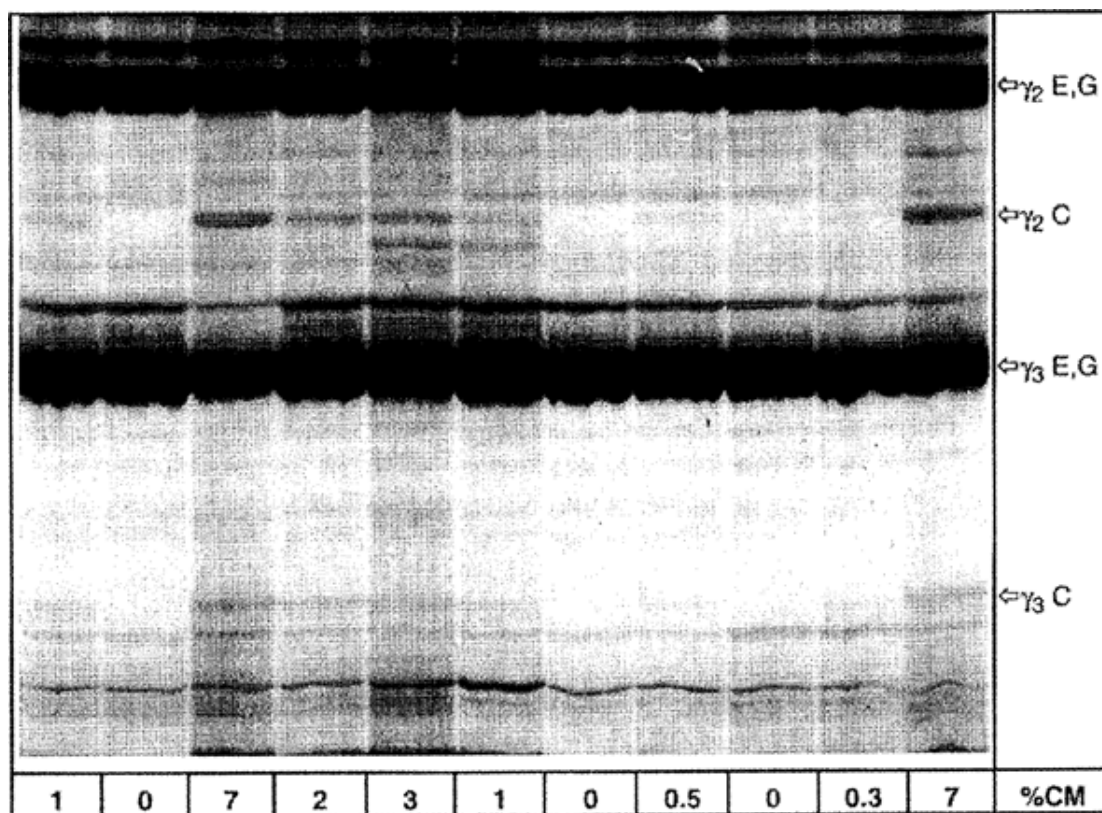

% CM = percentage of cow's milk, C = cow, E = ewe, G = goat

Upper half of the IEF gel is shown.

Figure 4b Isoelectric focusing of plasmin treated caseins from cheese made from mixtures of ewe's, goat's and buffalo milk containing different amounts of cow's milk.

Status: Point in time view as at 07/02/2018.

Changes to legislation: There are currently no known outstanding effects for the Commission Implementing Regulation (EU) 2016/1240. (See end of Document for details)

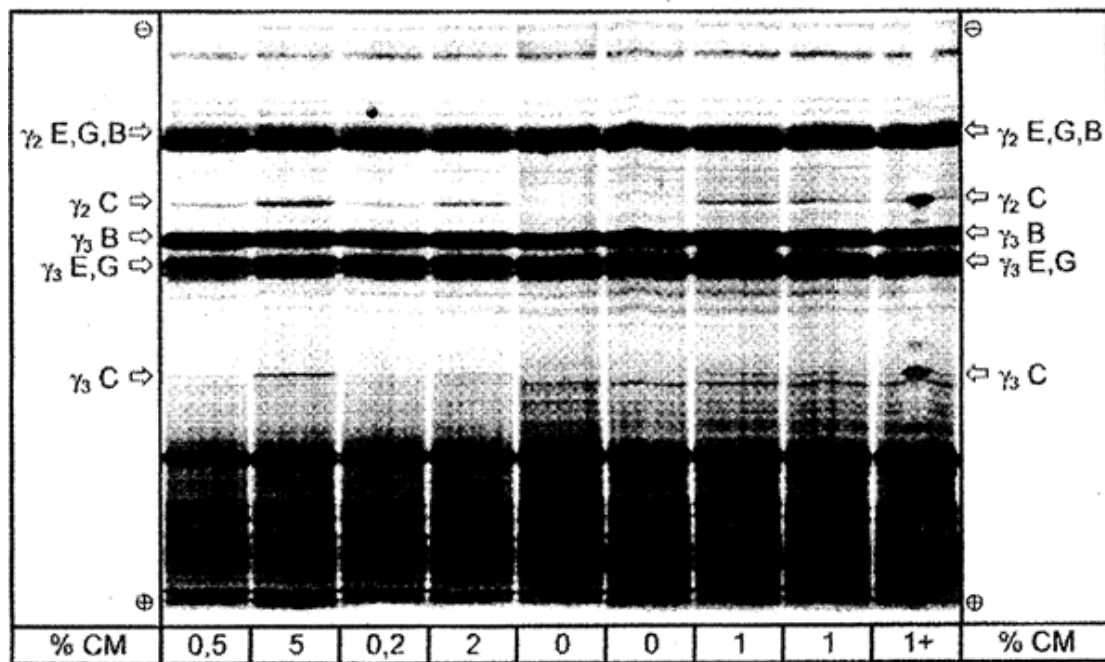

% CM = percentage of cow's milk; 1 + = sample containing 1 % of cow's milk and spiked with pure bovine casein at the middle of the track. C = cow, E = ewe, G = goat, B = buffalo.

Total separation distance of the IEF gel is shown.

Figure 5 Superposition of densitograms of standards (STD) and cheese samples made from a mixture of ewe's and goat's milk after isoelectric focusing.

Status: Point in time view as at 07/02/2018.

Changes to legislation: There are currently no known outstanding effects for the
Commission Implementing Regulation (EU) 2016/1240. (See end of Document for details)

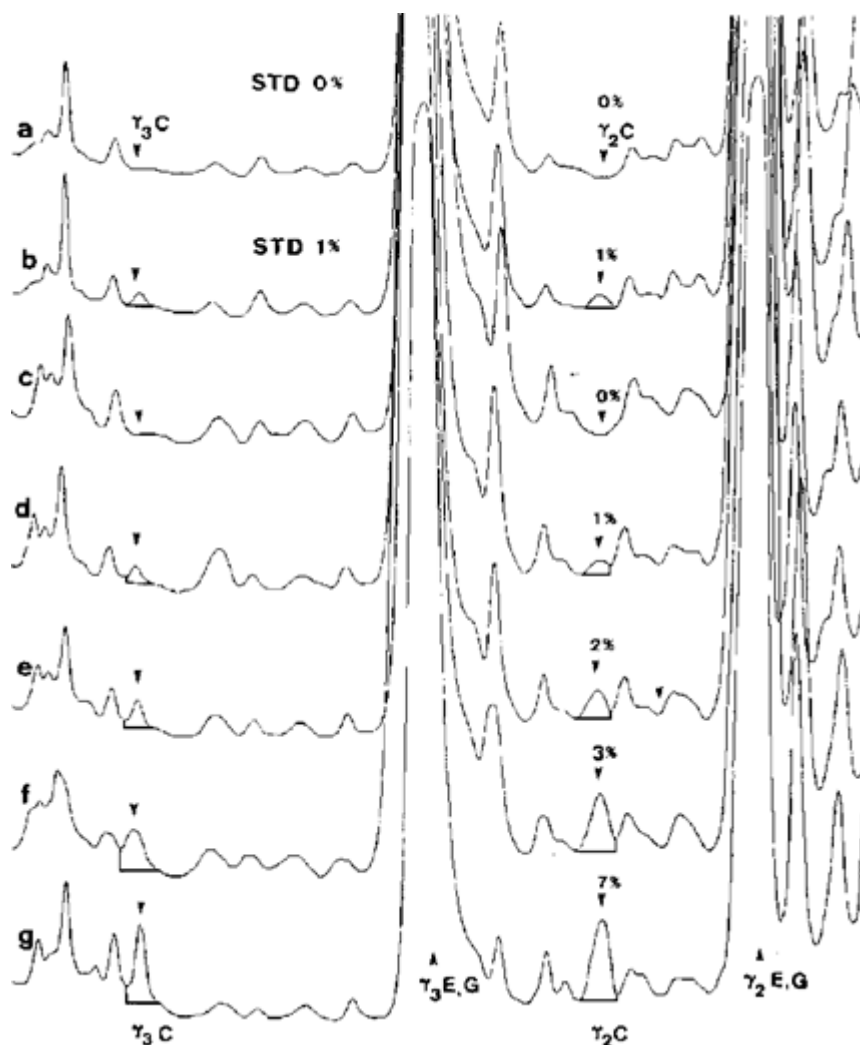

a,b = standards containing 0 and 1 % of cow's milk; c-g = cheese samples containing 0, 1, 2, 3 and 7 % of cow's milk. C = cow, E = ewe, G = goat.

Upper half of the IEF gel was scanned at $\lambda = 634$ nm.

ANNEX IX

Evaluation of the analyses

1. Quality assurance

Analyses shall be performed by laboratories designated in accordance with Article 12 of Regulation (EC) No 882/2004 (**) or designated by the competent authorities of the Member State.

2. Sampling and disputes over the results of analysis

1. Sampling shall be carried out in accordance with the relevant regulation for the product under consideration. If no sampling provisions are expressly provided for, then the provisions laid down in ISO 707, Milk and milk products – Guidance on sampling, shall be used.

Status: Point in time view as at 07/02/2018.

Changes to legislation: There are currently no known outstanding effects for the Commission Implementing Regulation (EU) 2016/1240. (See end of Document for details)

2. Laboratory reports of the results of the analysis shall contain sufficient information to allow an evaluation of the results to be carried out in accordance with the Appendix.
3. Duplicate samples shall be taken for analyses required under Union rules.
4. If a dispute arises over the results, the paying agency shall have the necessary analysis on the product in question carried out again, and the cost shall be met by the losing party.

The above mentioned analysis shall be carried out provided that sealed duplicate samples of the product are available and have been stored appropriately with the competent authority. The manufacturer shall send a request to the paying agency to conduct the analysis within 7 working days following the notification of the results of the first analysis. The analysis shall be carried out by the paying agency within 21 working days following receipt of the request.

5. The appeal result shall be the definitive one.
6. If the manufacturer can prove, within five working days of sampling, that the sampling procedure was not carried out correctly, sampling shall be repeated where possible. If sampling cannot be repeated, the consignment shall be accepted.

Appendix

Evaluation of compliance of a consignment with the legal limit

1. Principle

Where public intervention and private storage legislation lay down detailed sampling procedures then those procedures shall be followed. In all other cases a sample of at least 3 sample units taken randomly from the consignment submitted to control shall be used. A composite sample may be prepared. The result obtained shall be compared with the legal limits by calculation of a 95 % confidence interval as 2 x standard deviation, where the relevant standard deviation depends on whether (1) the method is validated through international collaboration with values for σ_r and σ_R or (2) in the case of in-house validation, an internal reproducibility has been calculated. This confidence interval will then equate to the measurement uncertainty of the result.

2. The method is validated through international collaboration

In this case, the repeatability standard deviation σ_r and the reproducibility standard deviation σ_R have been established and the laboratory can demonstrate compliance with the performance characteristics of the validated method.

Calculate the arithmetic mean

\bar{x}

of the n repeated measurements.

Calculate the expanded uncertainty ($k = 2$) of

\bar{x}

as

$$U = 2\sqrt{\sigma_2^R - \frac{n-1}{n}\sigma_2^r}$$

Status: Point in time view as at 07/02/2018.

*Changes to legislation: There are currently no known outstanding effects for the
Commission Implementing Regulation (EU) 2016/1240. (See end of Document for details)*

If the final result x of measurement is calculated using a formula of the form $x = y_1 + y_2$, $x = y_1 - y_2$, $x = y_1 \cdot y_2$ or $x = y_1/y_2$ the usual procedures for combining standard deviations in such cases shall be followed.

The consignment is judged to be not in compliance with the upper legal limit UL if

$$\bar{x} - U > UL$$

;

otherwise it is judged to be in compliance with UL.

The consignment is judged to be not in compliance with the lower legal limit LL if

$$\bar{x} + U < LL$$

;

otherwise it is judged to be in compliance with LL.

3. **In-house validation with calculation of internal reproducibility standard deviation**

In cases where methods not specified in this Regulation are used and precision measures have not been established, an in-house validation shall be carried out. Internal repeatability standard deviation σ_{ir} and the internal reproducibility standard deviation σ_{iR} shall be used instead of σ_r and σ_R , resp., in the formulae for the computation of the expanded uncertainty U .

The rules to be followed to determine compliance with the legal limit are as set out under point 1. However, if the consignment is judged to be non-compliant with the legal limit, the measurements shall be repeated with the method specified in this Regulation and the result evaluated in accordance to point 1.

- (*) The produce Ampholine® pH 3,5-9,5 (Pharmacia) and Resolyte® pH 5-7 and pH 6-8 (BDH, Merck) have proved particularly suitable for obtaining the required separation of γ -caseins.
- (**) Regulation (EC) No 882/2004 of the European Parliament and of the Council of 29 April 2004 on official controls performed to ensure the verification of compliance with feed and food law, animal health and animal welfare rules ([OJ L 165, 30.4.2004, p. 1](#)).

Status: Point in time view as at 07/02/2018.

*Changes to legislation: There are currently no known outstanding effects for the
Commission Implementing Regulation (EU) 2016/1240. (See end of Document for details)*

- (1) OJ L 347, 20.12.2013, p. 671.
- (2) OJ L 347, 20.12.2013, p. 549.
- (3) OJ L 346, 20.12.2013, p. 12.
- (4) Council Regulation (EC) No 1234/2007 of 22 October 2007 establishing a common organisation of agricultural markets and on specific provisions for certain agricultural products (Single CMO Regulation) (OJ L 299, 16.11.2007, p. 1).
- (5) Commission Regulation (EEC) No 3427/87 of 16 November 1987 laying down detailed rules for intervention on the market in rice (OJ L 326, 17.11.1987, p. 25).
- (6) Commission Regulation (EEC) No 2351/91 of 30 July 1991 laying down detailed rules applicable on the purchase of rice held by an intervention agency for the supply of food aid (OJ L 214, 2.8.1991, p. 51).
- (7) Commission Regulation (EC) No 720/2008 of 25 July 2008 laying down common detailed rules for the application of Council Regulation (EC) No 1234/2007 as regards the storage and movement of products bought in by a paying agency or an intervention agency (OJ L 198, 26.7.2008, p. 17).
- (8) Commission Regulation (EC) No 826/2008 of 20 August 2008 laying down common rules for the granting of private storage aid for certain agricultural products (OJ L 223, 21.8.2008, p. 3).
- (9) Commission Regulation (EC) No 1130/2009 of 24 November 2009 laying down common detailed rules for verifying the use and/or destination of products from intervention (OJ L 310, 25.11.2009, p. 5).
- (10) Commission Regulation (EU) No 1272/2009 of 11 December 2009 laying down common detailed rules for the implementation of Council Regulation (EC) No 1234/2007 as regards buying-in and selling of agricultural products under public intervention (OJ L 349, 29.12.2009, p. 1).
- (11) Commission Delegated Regulation (EU) 2016/1238 of 18 May 2016 supplementing Regulation (EU) No 1308/2013 of the European Parliament and of the Council with regard to public intervention and aid for private storage (see page 15 of this Official Journal).
- (12) Commission Delegated Regulation (EU) No 907/2014 of 11 March 2014 supplementing Regulation (EU) No 1306/2013 of the European Parliament and of the Council with regard to paying agencies and other bodies, financial management, clearance of accounts, securities and use of euro (OJ L 255, 28.8.2014, p. 18).
- (13) Commission Implementing Regulation (EU) No 908/2014 of 6 August 2014 laying down rules for the application of Regulation (EU) No 1306/2013 of the European Parliament and of the Council with regard to paying agencies and other bodies, financial management, clearance of accounts, rules on checks, securities and transparency (OJ L 255, 28.8.2014, p. 59).
- (14) Regulation (EC) No 1107/2009 of the European Parliament and of the Council of 21 October 2009 concerning the placing of plant protection products on the market and repealing Council Directives 79/117/EEC and 91/414/EEC (OJ L 309, 24.11.2009, p. 1).
- (15) Commission Regulation (EC) No 1249/2008 of 10 December 2008 laying down detailed rules on the implementation of the Community scales for the classification of beef, pig and sheep carcasses and the reporting of prices thereof (OJ L 337, 16.12.2008, p. 3).
- (16) Commission Delegated Regulation (EU) No 906/2014 of 11 March 2014 supplementing Regulation (EU) No 1306/2013 of the European Parliament and of the Council with regard to public intervention expenditure (OJ L 255, 28.8.2014, p. 1).
- (17) [F²Regulation (EU) No 223/2014 of the European Parliament and of the Council of 11 March 2014 on the Fund for European Aid to the Most Deprived (OJ L 72, 12.3.2014, p. 1).]
- (18) Council Regulation (EEC, Euratom) No 1182/71 of 3 June 1971 determining the rules applicable to periods, dates and time limits (OJ L 124, 8.6.1971, p. 1).
- (19) Commission Regulation (EC) No 1848/2006 of 14 December 2006 concerning irregularities and the recovery of sums wrongly paid in connection with the financing of the common agricultural policy and the organisation of an information system in this field and repealing Council Regulation (EEC) No 595/91 (OJ L 355, 15.12.2006, p. 56).
- (20) Commission Regulation (EC) No 792/2009 of 31 August 2009 laying down detailed rules for the Member States' notification to the Commission of information and documents in implementation of

Status: Point in time view as at 07/02/2018.

Changes to legislation: There are currently no known outstanding effects for the
Commission Implementing Regulation (EU) 2016/1240. (See end of Document for details)

the common organisation of the markets, the direct payments' regime, the promotion of agricultural products and the regimes applicable to the outermost regions and the smaller Aegean islands (OJ L 228, 1.9.2009, p. 3).

- (21) Commission Regulation (EC) No 1881/2006 of 19 December 2006 setting maximum levels for certain contaminants in foodstuffs (OJ L 364, 20.12.2006, p. 5).
- (22) Commission Regulation (EC) No 401/2006 of 23 February 2006 laying down the methods of sampling and analysis for the official control of the levels of mycotoxins in foodstuffs (OJ L 70, 9.3.2006, p. 12).
- (23) Commission Regulation (EU) No 234/2010 of 19 March 2010 laying down certain detailed rules for the application of Council Regulation (EC) No 1234/2007 on the granting of export refunds on cereals and the measures to be taken in the event of disturbance on the market for cereals (OJ L 72, 20.3.2010, p. 3).
- (24) Regulation (EC) No 853/2004 of the European Parliament and of the Council of 29 April 2004 laying down specific hygiene rules for food of animal origin (OJ L 139, 30.4.2004, p. 55).

Textual Amendments

- F2** Inserted by Commission Implementing Regulation (EU) 2017/1479 of 16 August 2017 amending Implementing Regulation (EU) 2016/1240 as regards the disposal of intervention stocks for the scheme for food distribution to the most deprived.

Status:

Point in time view as at 07/02/2018.

Changes to legislation:

There are currently no known outstanding effects for the Commission Implementing Regulation (EU) 2016/1240.