

Commission Delegated Regulation (EU) 2016/1788 of 14 July 2016 amending Regulation (EU) No 167/2013 of the European Parliament and of the Council as regards the list of requirements for vehicle EU type-approval, and amending and correcting Commission Delegated Regulations (EU) No 1322/2014, (EU) 2015/96, (EU) 2015/68 and (EU) 2015/208 with regard to vehicle construction and general requirements, to environmental and propulsion unit performance requirements, to vehicle braking requirements and to vehicle functional safety requirements (Text with EEA relevance)

COMMISSION DELEGATED REGULATION (EU) 2016/1788
of 14 July 2016

amending Regulation (EU) No 167/2013 of the European Parliament and of the Council as regards the list of requirements for vehicle EU type-approval, and amending and correcting Commission Delegated Regulations (EU) No 1322/2014, (EU) 2015/96, (EU) 2015/68 and (EU) 2015/208 with regard to vehicle construction and general requirements, to environmental and propulsion unit performance requirements, to vehicle braking requirements and to vehicle functional safety requirements

(Text with EEA relevance)

THE EUROPEAN COMMISSION,

Having regard to the Treaty on the Functioning of the European Union,

Having regard to Regulation (EU) No 167/2013 of the European Parliament and of the Council of 5 February 2013 on the approval and market surveillance of agricultural and forestry vehicles⁽¹⁾, and in particular Articles 17(5), 18(4), 19(6), 20(8), 27(6), 28(6), 49(3), 53(12), 60(1) and Articles 61 and 70 thereto,

Whereas:

- (1) As Article 27(3) of Regulation (EU) No 167/2013 allows for the use of virtual testing methods as an alternative to the physical tests performed by designated technical services, and considering that such virtual testing methods reduce considerably the burden on manufacturers and are particularly easy to apply with regard to dimensional checking, further requirements should be added to the list of requirements which may be subject to virtual testing set out in Annex III to Commission Delegated Regulation (EU) No 1322/2014⁽²⁾.
- (2) In order to improve the accuracy, the technical requirements related to the measuring apparatus for the driver-perceived noise level set out in Annex XIII to Delegated Regulation (EU) No 1322/2014 should be updated to technical progress.
- (3) To ensure consistency it is necessary to provide further conditions for EU component type-approval of a seat in Annex XIV to Delegated Regulation (EU) No 1322/2014.

- (4) For the purposes of clarity and accuracy, further requirements on the information to be included in the operator's manual in accordance with Annex XXII to Delegated Regulation (EU) No 1322/2014 should be added, in particular with regard to the information on how to fix the three-point hitch laterally and vertically for road travel, on instructions and specific warnings on the reduced dimensions of the protective device for a power take-off Type 3 and on the greasing intervals.
- (5) Due to their technical design, vehicles of category T or C with a hydrostatic drive controlled by the right foot and vehicles of category C with a maximum design speed of less than 15 km/h referred to in Annex XXIII to Delegated Regulation (EU) No 1322/2014 regarding control devices should be exempted from the requirement of having clutch, brake and accelerator pedals with the same function and arrangement as those of a motor vehicle.
- (6) To improve the accuracy, the requirements for the safe start of the engine set out in Annex XXIII to Delegated Regulation (EU) No 1322/2014 should be improved and adapted to the particularities of certain vehicle designs.
- (7) To ensure consistency with Delegated Regulation (EU) No 1322/2014, requirements for control devices related to virtual terminals, set out in Annex X to Commission Delegated Regulation (EU) 2015/208⁽³⁾ regarding requirements on driver information systems, should be moved to Annex XXIII to Delegated Regulation (EU) No 1322/2014 regarding requirements on control devices.
- (8) For the purposes of consistency and simplification, the marking requirements for the flexible hydraulic hoses set out in Annex XXIV to Delegated Regulation (EU) No 1322/2014 regarding protection against other mechanical hazards should be harmonised with standard ISO 17165-1:2007 currently used by hose manufacturers.
- (9) To ensure consistency it is necessary to include in the scope of Annex XXIX to Delegated Regulation (EU) No 1322/2014 regarding protection against hazardous substances, any tractor fitted with a cab, including those fitted with cabs of level 1, even if they do not provide any protection.
- (10) In order to ensure that the meaning of the term 'cab' is understood in the same way, a definition for 'cab' should be introduced in Delegated Regulation (EU) 2015/208. The definition should be based on the internationally recognised standard EN 15695-1:2009.
- (11) The calculation of tractors' maximum theoretical speed set out in Annex III to Delegated Regulation (EU) 2015/208 should take into account the latest technical developments regarding engine control.
- (12) The conditions for fulfilment of ISO requirements set out in Annex VII to Delegated Regulation (EU) 2015/208 regarding field of vision and windscreen wipers do not expressly include conditions regarding direct and indirect vision. Conditions regarding direct and indirect vision should be expressly stated in that Annex to ensure that the ISO requirements are fulfilled uniformly.
- (13) Lighting installations referred to in Annex XII to Delegated Regulation (EU) 2015/208 should comply with certain stricter requirements for fast tractors, to increase their safety.

- (14) Control devices, providing the driver with haptic information, have protruding edges. In order to protect vehicle occupants while retaining the possibility to provide haptic information, it is necessary to introduce specific requirements for those devices in Annex XIII to Delegated Regulation (EU) 2015/208.
- (15) Specific requirements should be introduced in Annex XIV to Delegated Regulation (EU) 2015/208 for the exterior and accessories of agricultural and forestry vehicles, due to the particular purpose of certain exterior configurations.
- (16) The requirements for cab heating and cooling in Annex XVII to Delegated Regulation (EU) 2015/208 should be compatible with the requirements of Annex XXIX to Delegated Regulation (EU) No 1322/2014 regarding the pressure level and the air flow.
- (17) It is necessary to improve the visibility of the registration plates referred to in Annex XIX to Delegated Regulation (EU) 2015/208.
- (18) Certain requirements for the fuel tanks in Annex XXV to Delegated Regulation (EU) 2015/208 should be aligned with the latest technical developments set out in the United Nations Economic Commission for Europe (UNECE) Regulation No 34.
- (19) Due to particular dimensions of T2 tractors, it is necessary to adapt the length of platform specified in Annex XXVIII to Delegated Regulation (EU) 2015/208.
- (20) The towing device requirements in Annex XXIX to Delegated Regulation (EU) 2015/208 need to be adapted to take into account the latest technical developments.
- (21) Additional definitions are necessary in relation to tracks in Annex XXXIII to Delegated Regulation (EU) 2015/208. It is also necessary to update a number of the existing definitions to take into account the latest technical developments.
- (22) Additional terms and requirements are necessary in relation to mechanical couplings in Annex XXXIV to Delegated Regulation (EU) 2015/208, to ensure the consistency of tests on both towing vehicle (tractor) and towed vehicle (trailer or interchangeable towed equipment). Number of the terms and requirements in relation to mechanical couplings need to be adapted to avoid the use of the same terms in different contexts.
- (23) Certain terms and requirements related to braking of agricultural and forestry vehicles in Annex I to Commission Delegated Regulation (EU) 2015/68⁽⁴⁾ should be aligned with the latest technical developments regarding construction and fitting of brakes.
- (24) Braking tests set out in Annex II to Delegated Regulation (EU) 2015/68 should be aligned with the latest technical developments regarding the braking behaviour and performance and with corresponding requirements of UNECE Regulation No 13.
- (25) Additional definitions in relation to alternative braking tests are necessary and certain terms and requirements concerning alternative braking tests set out in Annex VII to Delegated Regulation (EU) 2015/68 should be clarified to fully align with the requirements laid down in UNECE Regulation No 13.
- (26) Certain terms and requirements related to braking of agricultural and forestry vehicles with hydrostatic drive set out in Annex IX to Delegated Regulation (EU) 2015/68 should

Changes to legislation: There are currently no known outstanding effects for the Commission Delegated Regulation (EU) 2016/1788. (See end of Document for details)

be aligned with the latest technical developments regarding the performance of brakes installed in such vehicles.

- (27) The requirements in Annex XII to Delegated Regulation (EU) 2015/68 for electronically controlled braking systems on certain tractors should be adapted to avoid failures to the greatest possible degree and to increase braking performance.
- (28) The definitions regarding engine pollutant emissions set out in Commission Delegated Regulation (EU) 2015/96⁽⁵⁾ should be aligned with the corresponding definitions used in relation to non-road mobile machinery. It is also necessary to fully align the requirements in relation to non-road mobile machinery set out in that Regulation with the requirements set out in Directive 97/68/EC of the European Parliament and of the Council⁽⁶⁾ and with UNECE Regulation No 96.
- (29) In order to improve the readability and clarity of Delegated Regulation (EU) No 1322/2014, Delegated Regulation (EU) 2015/96, Delegated Regulation (EU) 2015/68 and Delegated Regulation (EU) 2015/208, it is necessary to correct some editorial mistakes, contradictions and wrong references.
- (30) Annex I to Regulation (EU) No 167/2013 regarding requirements for vehicle EU type-approval should allow laying down functional safety requirements for additional vehicle categories where that is necessary.
- (31) Regulation (EU) No 167/2013 should therefore be amended accordingly.
- (32) Delegated Regulation (EU) No 1322/2014, Delegated Regulation (EU) 2015/96, Delegated Regulation (EU) 2015/68 and Delegated Regulation (EU) 2015/208 should therefore be amended and corrected accordingly.
- (33) Given that Regulation (EU) No 167/2013, Delegated Regulation (EU) No 1322/2014, Delegated Regulation (EU) 2015/96, Delegated Regulation (EU) 2015/68 and Delegated Regulation (EU) 2015/208 are already applicable and that the amendments to those acts include number of corrections, this Regulation should enter into force as soon as possible,

HAS ADOPTED THIS REGULATION:

Article 1

Amendments to Regulation (EU) No 167/2013 on the approval and market surveillance of agricultural and forestry vehicles

Annex I to Regulation (EU) No 167/2013 is amended in accordance with Annex I to this Regulation.

Article 2

Amendments to Delegated Regulation (EU) No 1322/2014

Delegated Regulation (EU) No 1322/2014 is amended in accordance with Annex II to this Regulation.

Article 3

Amendments to Delegated Regulation (EU) 2015/96

Delegated Regulation (EU) 2015/96 is amended as follows:

- (1) Article 2 is amended as follows:
 - (a) the first sentence and the introductory sentence are replaced by the following:

For the purposes of this Regulation, the definitions in Annex XXXIII to Commission Delegated Regulation (EU) 2015/208⁽⁷⁾ shall apply. The following definitions shall also apply:
 - (b) point (2) is replaced by the following:
 - (2) “pollutant exhaust emissions after-treatment system” means the passage of exhaust gases through a device or system whose purpose is to chemically or physically alter the emitted pollutants prior to their release to the atmosphere, including catalysts, particulate traps or any other component, system or separate technical unit for the reduction or treatment of the engine gaseous and particulate matter exhaust pollutant emissions;
 - (c) points (4) and (5) are replaced by the following:
 - (4) “pollution control device” means a component, system or separate technical unit which is part of the pollutant exhaust emissions after-treatment system;
 - (5) “replacement pollution control device” means a component, system or separate technical unit intended to replace, partially or fully, a pollutant exhaust emissions after-treatment system on a vehicle type-approved in accordance with Regulation (EU) No 167/2013 and this Regulation;
 - (d) point (12) is replaced by the following:
 - (12) “net power” means the engine power obtained on a test bench at the end of the crankshaft or its equivalent at the corresponding engine speed with the auxiliaries, listed in Table 1 of Annex 4 to UNECE Regulation No 120, 01 series of amendments⁽⁸⁾, determined under reference atmospheric conditions.;
- (2) Article 4 is amended as follows:
 - (a) paragraph 2 is replaced by the following:
 2. The type-approval regarding exhaust pollutant emissions and external sound level requirements may be extended by the type-approval authorities to different vehicle variants, versions and engine types and families, provided that the vehicle variant, version, propulsion unit and pollution control system parameters have an identical performance or remain within the levels specified in Article 19(3) and (4) of Regulation (EU) No 167/2013.

- (b) in paragraph 3, points (a) and (b) are replaced by the following:
- (a) the parameters of the engine type or engine family, as set out in Annex II to Directive 97/68/EC and in point 9.1 of Annex I to this Regulation;
 - (b) the engine's pollutant exhaust emissions after-treatment system, as described in point 6.10 of Annex I to Directive 97/68/EC and point 9.1.10 of Annex I to this Regulation and point 3.3 of Annex II to this Regulation;
- (c) in paragraph 4, points (d), (e) and (f) are replaced by the following:
- (a) as regards the reference fuels, the requirements set out in Annex 7 to UNECE Regulation No 120, 01 series of amendments or Annex V to Directive 97/68/EC;
 - (b) as regards pollution control devices and replacement pollution control devices, the requirements set out in Appendix 5 of Annex III to Directive 97/68/EC;
 - (c) as regards test equipment, the requirements set out in Annex III to Directive 97/68/EC.
- (3) in Article 7, paragraph 2 is replaced by the following:
2. In addition to the requirements referred to in the first paragraph, for an alternative type-approval to be recognised as equivalent to an approval under this Regulation, the manufacturer shall provide non-discriminatory access to vehicle repair and maintenance information as required by Chapter XV of Regulation (EU) No 167/2013 and Article 8 of Commission Delegated Regulation (EU) No 1322/2014⁽⁹⁾.
- (4) Article 9 is replaced by the following:

Article 9

Measurement of the external sound level

- 1 The technical services shall measure the external sound level of agricultural and forestry vehicles of category T equipped with pneumatic tyres and of category C equipped with track belts in motion, for type-approval purposes, in accordance with the test conditions and methods set out in point 1.3.1 of Annex III.
- 2 The test conditions and methods set out in point 1.3.2 of Annex III shall also be carried out for stationary agricultural and forestry vehicles of categories T and C equipped with track belts and the results shall be recorded by the technical services in accordance to the provisions of point 1.3.2.4 of Annex III.
- 3 The technical services shall measure the external sound level of agricultural and forestry vehicles of category C equipped with track chains, for type-approval purposes, in accordance with the stationary test conditions and methods set out in point 1.3.2 of Annex III.
- 4 The test conditions and methods set out in point 1.3.3 of Annex III shall be carried out for agricultural and forestry vehicles of category C equipped with track chains and the results shall be recorded by the technical services.

Changes to legislation: There are currently no known outstanding effects for the
Commission Delegated Regulation (EU) 2016/1788. (See end of Document for details)

- (5) Article 10 is replaced by the following:

Article 10

Requirements on propulsion unit performance

For the evaluation of propulsion unit performance of agricultural and forestry vehicles, measurements of net power, engine torque and specific fuel consumption shall be carried out in accordance with UNECE Regulation No 120, 01 series of amendments.

- (6) in Article 11(4), the first sentence is replaced by the following:

For the purposes of type-approval, the dates set out in Articles 9(3c), 9(3d) and 9(4a) of Directive 97/68/EC shall, for agricultural and forestry vehicles of categories T2, T4.1 and C2, as defined in Article 4(3), (6) and (9) of Regulation (EU) No 167/2013 and equipped with engines of categories L to R, be postponed for 3 years.

- (7) Article 12 is replaced by the following:

Article 12

EU type-approval procedures

Without prejudice to Article 11, if a manufacturer so requests, national authorities may not, on grounds relating to emissions of vehicles, refuse to grant EU type-approval or national type-approval for a new type of vehicle or engine, or prohibit the registration, sale or entry into service of a new vehicle and the sale or use of new engines, where the vehicle or engines concerned comply with Regulation (EU) No 167/2013 and Commission Implementing Regulation (EU) 2015/504⁽¹⁰⁾.

- (8) in Article 14, paragraph 1 is replaced by the following:

1. By way of derogation from Article 4(1), concerning the pollutant emissions, Member States shall allow the placing on the market of a limited number of vehicles fitted with engines meeting the requirements of Article 9 of Directive 97/68/EC under a flexibility scheme, in accordance to the provisions of Annex V to this Regulation, at the request of the manufacturer, and on condition that an approval authority has granted the relevant permit for entry into service.

- (9) Annexes I to IV are amended in accordance with Annex III to this Regulation.

Article 4

Amendments to Delegated Regulation (EU) 2015/68

Delegated Regulation (EU) 2015/68 is amended as follows:

- (1) Article 2 is amended as follows:
 - (a) the first sentence and the introductory sentence are replaced by the following:

Changes to legislation: There are currently no known outstanding effects for the Commission Delegated Regulation (EU) 2016/1788. (See end of Document for details)

For the purposes of this Regulation, the definitions in Article 2 and Annexes XII and XXXIII to Commission Delegated Regulation (EU) 2015/208⁽¹¹⁾ shall apply. The following definitions shall also apply:

- (b) point (5) is replaced by the following:
 - (5) “transmission” means the combination of components comprised between the control device and the brake, excluding the control lines, supply lines and supplementary lines between tractors and towed vehicles, and linking them functionally through mechanical, hydraulic, pneumatic or electric means or through the use of a combination of those means; where the braking power is derived from or assisted by a source of energy independent of the driver, the reserve of energy in the system is likewise part of the transmission;
 - (c) point (17) is deleted;
 - (d) the following points (37) and (38) are added:
 - (37) “energy source” means a device that provides the energy required to actuate the brakes, either directly or indirectly through an energy storage device;
 - (38) “energy storage device” means a device that stores the energy provided by the energy source to apply or release the brakes.
- (2) Annexes I to V, VII, VIII, IX, XI, XII and XIII are amended in accordance with Annex IV to this Regulation.

Article 5

Amendments to Delegated Regulation (EU) 2015/208

Delegated Regulation (EU) 2015/208 is amended as follows:

- (1) Article 2 is amended as follows:
 - (a) point (5) is replaced by the following:
 - (5) “Tyres normally fitted” means the type or types of tyre provided by the manufacturer on the vehicle type in question and specified in the information document the template of which is set out in Article 2 of Commission Implementing Regulation (EU) 2015/504⁽¹²⁾;
 - (b) point (6) is replaced by the following:
 - (6) “Tracks normally fitted” means the type or types of track provided by the manufacturer on the vehicle type in question and specified in the information document the template of which is set out in Article 2 of Implementing Regulation (EU) 2015/504;
 - (c) point (12) is replaced by the following:
 - (12) “Laden vehicle” means a vehicle loaded at its technically permissible maximum laden mass;
 - (d) the following point (13) is added:

Changes to legislation: There are currently no known outstanding effects for the
Commission Delegated Regulation (EU) 2016/1788. (See end of Document for details)

- (13) “cab” means the operator enclosure which surrounds the operator by means of a physical barrier and prevents the free passage of external air into the area of the operator.
- (2) in Article 5, paragraph 3 is replaced by the following:
3. The measurement methods and test results shall be reported to the approval authority in the test report format set out in Article 9 of Implementing Regulation (EU) 2015/504.
- (3) Annexes I, III, V, VII, X, XII to XV, XVII, XIX, XX, XXII, XXV to XXXI, XXXIII and XXXIV are amended in accordance with Annex V to this Regulation.

Article 6

Entry into force

This Regulation shall enter into force on the day following that of its publication in the *Official Journal of the European Union*.

This Regulation shall be binding in its entirety and directly applicable in all Member States.

Done at Brussels, 14 July 2016.

For the Commission

The President

Jean-Claude JUNCKER

ANNEX I

Annex I to Regulation (EU) No 167/2013 is amended as follows:

- (1) in row ‘Nr 6’, in the cell corresponding to the column ‘Regulatory act reference’, the following abbreviation is inserted:
‘RVFSR’;
- (2) in row ‘Nr 9’, the entry corresponding to vehicle category T3a is replaced by ‘X’;
- (3) in row ‘Nr 17’, the entry corresponding to vehicle category T3b is replaced by ‘X’;
- (4) in row ‘Nr 23’, the entries corresponding to vehicle categories T3a and T3b are replaced by ‘X’;
- (5) in row ‘Nr 30’, the entries corresponding to vehicle categories Ca and Cb are replaced by ‘X’;
- (6) in row ‘Nr 34’, in the cell corresponding to vehicle category T3b, the following letter is inserted:
‘X’.

ANNEX II

Annexes III, V, VIII, IX, X, XIII to XVIII, XXI to XXIV, XXVI and XXIX to Delegated Regulation (EU) No 1322/2014 are amended as follows:

- (1) Annex III is amended as follows:
 - (a) in point 5.2, Table 1 is replaced by the following:

TABLE 1

List of requirements which may be subject to virtual testing

Delegated act reference	Annex No	Requirements	Restrictions/ comments
Regulation (EU) No 1322/2014	IX	continuous or interrupted roll over behaviour in case of a laterally overturning narrow track tractor with a protective frame mounted in front of the driver’s seat	Section B4
Regulation (EU) No 1322/2014	XV	Requirements applying to operating space	Only requirements related to

Changes to legislation: There are currently no known outstanding effects for the Commission Delegated Regulation (EU) 2016/1788. (See end of Document for details)

		and to access to the driving position	dimensions and positioning
Regulation (EU) 2015/208	VII	Requirements on the field of vision and windscreen wipers	Only requirements related to dimensions, positioning and visibility
Regulation (EU) 2015/208	IX	Requirements on rear view mirrors	Only requirements related to dimensions, positioning and visibility
Regulation (EU) 2015/208	XII	Requirements on lighting installation	Only requirements related to dimensions, positioning and visibility in point 5 and 6 (with the exception of colorimetric or photometric requirements)
Regulation (EU) 2015/208	XIII	Requirements on vehicle occupant protection, including interior fittings, head restraints, seat belts, vehicle doors	Part 2 Only requirements related to dimensions, including detailed shape, and positioning
Regulation (EU) 2015/208	XIV	Requirements on vehicle exterior and accessories	Only requirements related to dimensions, including detailed shape, and positioning

(b) point 6.2.2 is replaced by the following:

6.2.2. Validation process of the mathematical model

The mathematical model shall be validated in comparison with the actual test conditions. A physical test shall be conducted for the purposes of comparing the results obtained when using the mathematical model with the results of a physical test. Comparability of the test results shall be proven. For that purpose, manufacturers shall provide the technical service with a

Changes to legislation: There are currently no known outstanding effects for the Commission Delegated Regulation (EU) 2016/1788. (See end of Document for details)

correlation report containing the information on the mathematical model and the correlation between the results obtained with such model and those obtained in the physical tests in accordance with the scheme set out in point 6.1. A validation report, confirming the compliance of the mathematical model, shall be drafted by the manufacturer or by the technical service and submitted to the approval authority. Any change made to the mathematical model or to the software likely to invalidate the validation report shall be brought to the attention of the approval authority, which may require that a new validation process is conducted. The flow chart of the validation process is shown in Figure 1 of point 7.

- (c) the following points 6.2.7 and 6.2.8 are inserted:

6.2.7. Approval process when using virtual testing

The compliance with the requirements set out in Table 1 of point 5.2. may be demonstrated by virtual testing procedures only if these are carried out in accordance with a mathematical model validated in accordance with the requirements set out in point 6.2.2. The applicability and restrictions of the model shall be agreed with the technical services and shall be subject to the approval of the approval authority.

6.2.8. Virtual testing test report

A test report of the virtual testing results shall be provided by the technical service. The test report should be coherent with the correlation report and the validation report and shall include at least the following elements: the building of a virtual prototype, the simulation inputs and the simulation results related to the technical requirements.

- (2) Annex V is amended as follows:

- (a) the following point 4.4 is inserted:

4.4. Point 4.1.2 shall apply from 1.7.2021.

However, manufacturers of vehicles of R- and S-category that do not employ diagnostic tools or a physical or wireless communication with the on-board electronic control unit(s) for the purposes of diagnostics or reprogramming of their vehicles are exempted from the obligations set out in point 4.1.2.

- (b) point 6.2 is replaced by the following:

6.2. Vehicles, systems, components and separate technical units covered by point 6.1 shall be listed on the manufacturer's repair and maintenance information website.

- (c) in Appendix 1, point 2.5 and points 2.5.1 to 2.5.4 are replaced by the following:

2.5. Reprogramming and diagnostics of control units for the purposes of recalibration after a repair or loading software to a replacement ECU or recoding or reinitialising replacement parts or components, must allow the use of non-proprietary hardware.

Changes to legislation: There are currently no known outstanding effects for the Commission Delegated Regulation (EU) 2016/1788. (See end of Document for details)

- 2.5.1. Reprogramming and diagnostics (PC-VCI communication interface) shall be conducted in accordance with either ISO 22900-2, SAE J2534 or TMC RP1210 from 1.7.2021;

However, the first paragraph shall apply from 1.7.2023 to the following manufacturers:

- (a) manufacturers of vehicles of R- and S-category;
- (b) manufacturers of vehicles of T- and C-category whose production is below the limits set out in point 6.1 of this Annex;
- (c) manufacturers of systems, components or separate technical units whose production is below the limits set out in point 6.1 of this Annex.

- 2.5.2. Ethernet, serial cable or Local Area Network (LAN) interface and alternative media like Compact Disc (CD), Digital Versatile Disc (DVD) or solid state memory device may also be used, but on the condition that no proprietary communication software (e.g. drivers or plug-ins) and hardware is required. For the validation of the compatibility of the manufacturer-specific application and the vehicle communication interfaces (VCI) complying to ISO 22900-2, SAE J2534 or TMC RP1210, the manufacturer shall offer either a validation of independently developed VCIs or the information, and loan of any special hardware, required for a VCI manufacturer to conduct such validation himself. The conditions set out in Article 55 of Regulation (EU) No 167/2013 shall apply to fees for such validation or information and hardware.

- 2.5.3. Co-existence of vehicle manufacturers' software shall be ensured from 1.7.2021;

However, the first paragraph shall apply from 1.7.2023 to the following manufacturers:

- (a) manufacturers of vehicles of R- and S-category;
- (b) manufacturers of vehicles of T- and C-category whose production is below the limits set out in point 6.1 of this Annex;
- (c) manufacturers of systems, components or separate technical units whose production is below the limits set out in point 6.1 of this Annex.

- 2.5.4. To ensure communication between the vehicle and diagnostic tools, the following standards shall apply for the physical diagnostic connectors between VCI and vehicle: SAE J1939-13, ISO 11783-2, ISO 15031-3 and ISO 13400-4.

- (3) in Annex VIII, figure 4.3.b is replaced by the following:

Figure **Two-post ROPS**
4.3.b

Changes to legislation: There are currently no known outstanding effects for the Commission Delegated Regulation (EU) 2016/1788. (See end of Document for details)

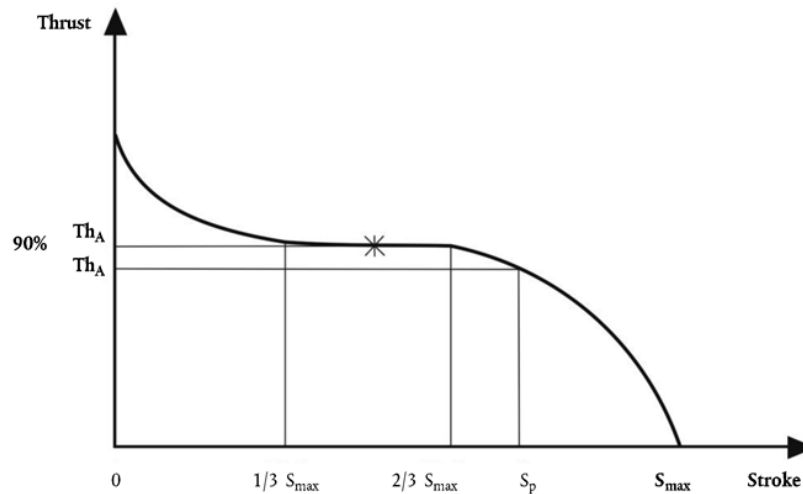

- (4) in section B1 of Annex IX, point 3.1.4.3.3 is replaced by the following:

3.1.4.3.3. The computer programme (BASIC) for determining the continuous or interrupted roll-over behaviour of a laterally overturning narrow-track tractor with a front-mounted roll-over protective structure is described in section B4, with examples 6.1 to 6.11.

- (5) in section B2 of Annex X, point 4.2.1.6 is replaced by the following:

4.2.1.6. Additional impact tests

If cracks or tears which cannot be considered negligible appear during an impact test, a second, similar test, but with a height of fall of:

$$H' = (H \times 10^{-1}) (12 + 4a)(1 + 2a)^{-1}$$

shall be performed immediately after the impact tests causing these tears or cracks to appear, “a” being the ratio of the permanent deformation (Dp) to the elastic deformation (De):

$$a = Dp / De$$

as measured at the point of impact. The additional permanent deformation due to the second impact shall not exceed 30 per cent of the permanent deformation due to the first impact.

In order to be able to carry out the additional test, it is necessary to measure the elastic deformation during all the impact tests.

- (6) Annex XIII is amended as follows:

- (a) point 1.3 is replaced by the following:

1.3. Measuring apparatus

A precision quality sound level meter shall be used meeting the requirements of the International Electrotechnical Commission Standards IEC 61672-1:2013 Electroacoustics - Sound level meters - Part 1:

Specifications. Measurement shall be carried out with a frequency weighting network in conformity with curve A and set to give slow response as is described in the IEC publication.

- (b) the following points 1.3.1, 1.3.2 and 1.3.3 are inserted:
- 1.3.1. The equipment shall be calibrated frequently and, if possible, before each measuring session.
- 1.3.2. An adequate technical description of measuring equipment shall be given in the test report.
- 1.3.3. In the case of variable readings, the average of the maximum values shall be taken.
- (c) in point 2.2.1, the second paragraph is replaced by the following:
- The microphone diaphragm must face forward and the centre of the microphone must be 790 mm above and 150 mm forward of the Seat Reference Point (S) described in Appendix 8 to Annex XIV. Excessive vibration of the microphone must be avoided.
- (d) in point 3.2.1, the second paragraph is replaced by the following:
- The microphone diaphragm must face forward and the centre of the microphone must be 790 mm above and 150 mm forward of the Seat Reference Point (S) described in Appendix 8 to Annex XIV. Excessive vibration of the microphone must be avoided.

(7) Annex XIV is amended as follows:

- (a) in the table of point 1.14, the first row is replaced by the following:

Class I	tractors having an unladen mass of up to 3 600 kg;
---------	--

- (b) in point 2.6.2, the first indent is replaced by the following:
- for length measurements: $\pm 0,5 \%$;
- (c) point 3.5.3.2.7 is replaced by the following:
- 3.5.3.2.7. The measurements at the point of seat attachment and on the seat itself shall be made during the same run.
- For measuring and recording the vibrations, an accelerometer, a measuring amplifier and a magnetic tape recorder, electronic system for data acquisition or direct-reading vibration meter shall be used. The specifications laid down in points 3.5.3.3.2 to 3.5.3.3.6 shall apply to those instruments.
- (d) point 3.5.3.3.4 is replaced by the following:
- 3.5.3.3.4. Magnetic tape recorder or electronic data acquisition system
- If a tape recorder or electronic system for data acquisition is used, it must have a maximum reproduction error of $\pm 3,5 \%$ in a frequency range of 1 to 80 Hz, including change of tape speed during replay for analysis.
- (e) the following section 4 is added:

Changes to legislation: There are currently no known outstanding effects for the Commission Delegated Regulation (EU) 2016/1788. (See end of Document for details)

4. Additional conditions for EU component type-approval of a seat

To be granted EU component type-approval, a seat shall, in addition to fulfilling the requirements set out in sections 2 and 3, satisfy the following conditions:

- (a) the range of adjustment as a function of the driver's mass extends from at least 50 to 120 kg;
 - (b) the change in the angle of inclination measured during the lateral stability test does not exceed 5°;
 - (c) neither of the two values set in point 3.5.3.3.7.2 exceed 1,25 m/s²;
 - (d) the ratio referred to in points 3.5.7.4 and 3.5.7.5 does not exceed the value of 2.
- (f) in Appendix 5, footnote (2) is replaced by the following:
- (2) The rearward inclination of the surface of the fitted seat cushion must be 3° to 12° in relation to the horizontal when measured with the loading device in accordance with Appendix 8. The choice of the angle of inclination within this class depends on the position when seated.
- (g) in Appendix 8, the following point 2.1 is added:

2.1. Positioning of the seat

For the purposes of Annex XV, the seat reference point (S) shall be obtained with the seat set in the rearmost longitudinal position and at the mid-point of the height adjustment range. Seats having a suspension system, whether or not adjustable according to the driver's weight, must be set at the mid-point of the suspension travel.

(8) Annex XV is amended as follows:

- (a) in the table of point 4.2, the third row is replaced by the following:

height clearance:	125 mm minimum,
-------------------	-----------------

- (b) in point 4.2.1, the second sentence is replaced by the following:

The vertical and horizontal distance between consecutive steps shall not be less than 150 mm; however, a tolerance of 20 mm between stages is allowed.

- (c) in Appendix 1, Figure 6 is replaced by the following:

Figure 6 (Source:EN ISO 4254-1 No. 4.7)

Changes to legislation: There are currently no known outstanding effects for the Commission Delegated Regulation (EU) 2016/1788. (See end of Document for details)

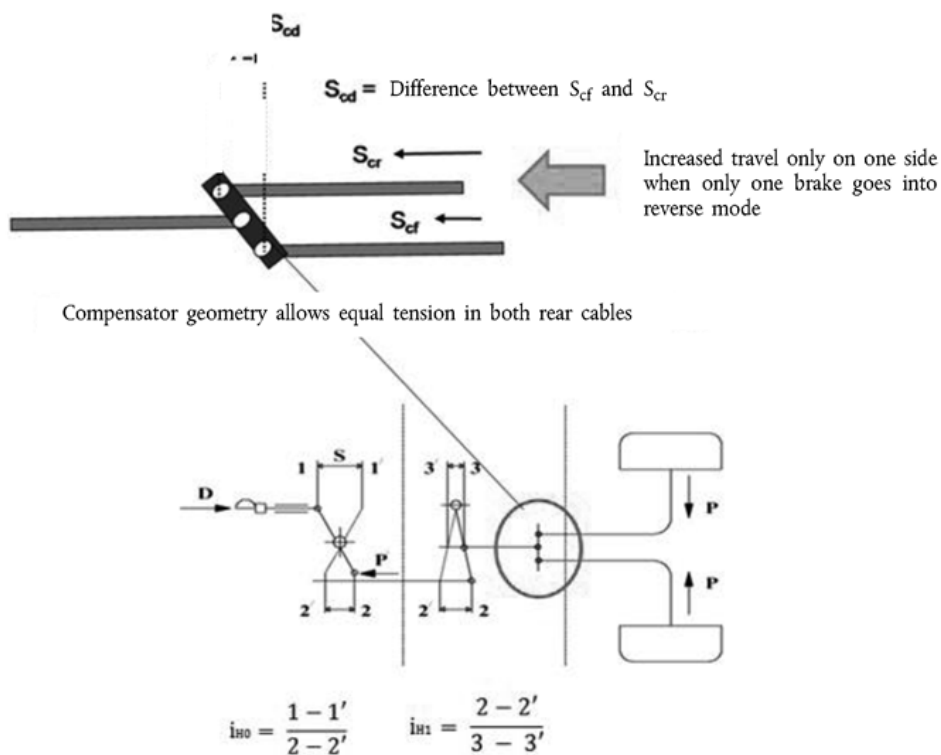

1.2 Control device

1.3 Transmission

1.4 Brakes";

(9) in Annex XVI, in point 1, Table 1 is amended as follows:

(a) the second row is replaced by the following:

ISO 500-1:2014(*)	X	–	X ₁₎	X ₁₎	X ₁₎	X
-------------------	---	---	-----------------	-----------------	-----------------	---

(b) footnote (***) is deleted;

(10) in Annex XVII, point 2.6 is replaced by the following:

2.6. The following securing devices shall be firmly attached either to the tractor mounting or to the protective device:

- (a) devices to secure quick-release mounting components;
- (b) components of protective devices which open without the aid of tools.

(11) in Annex XVIII, point 3.4 is replaced by the following:

3.4. Test result
Condition of acceptance

Changes to legislation: There are currently no known outstanding effects for the Commission Delegated Regulation (EU) 2016/1788. (See end of Document for details)

Permanent deformation of any system component and anchorage area is acceptable under the action of the forces specified in points 3.1 and 3.2. However, there shall be no failure allowing release of the seat belt system, seat assembly, or the seat adjustment locking mechanism.

The seat adjuster or locking device need not be operable after application of the test load.

(12) in Annex XXI, point 2.2 is replaced by the following:

2.2. The parts of the exhaust pipe which can be reached by the operator during normal operation of the tractor, as described in point 6.1 of Annex XVII, must be protected by means of segregation, guards or grids, so as to avoid the possibility of accidental contact with hot surfaces.

(13) Annex XXII is amended as follows:

(a) in point 2, point (ag) is replaced by the following:

(ag) information about the location of the greasing points, the safe greasing process and greasing intervals (daily/monthly/yearly);

(b) in point 3, point (g) is replaced by the following:

(g) information about the maximum lift capacity of the three-point lifting mechanism and information on how to fix the three-point lifting mechanism laterally and vertically for road travel;

(c) in point 3, point (l) is replaced by the following:

(l) information about using implements with power take-off drive shafts and that the technically possible inclination of the shafts depend on the shape and size of the master shield and clearance zone, including instructions and specific warnings relating to:

(i) coupling and releasing the power take-offs,

(ii) use of tools or machines coupled to the rear power take-off,

(iii) if applicable, use of PTO type 3 with reduced dimensions and the consequences and risks caused by the reduced dimension of the protective guard;

(14) Annex XXIII is amended as follows:

(a) in point 1.2, the first sentence is replaced by the following:

Control devices must satisfy the corresponding applicable requirements set out in points 1.2.1 to 1.2.4 as regards the installation, location, operation and identification of control devices.

(b) in point 1.2.3, the second paragraph is replaced by the following:

In order to avoid confusing the driver, the clutch, brake and accelerator pedals shall have the same function and arrangement as those of a motor vehicle, except for:

Changes to legislation: There are currently no known outstanding effects for the Commission Delegated Regulation (EU) 2016/1788. (See end of Document for details)

- (a) vehicles equipped with a straddle seat and handlebars, which are deemed to comply with the requirements of EN 15997:2011 for throttle control and manual clutch control,
 - (b) vehicles of category T or C requiring a sustained activation of the right pedal to keep them in motion (e.g. vehicles fitted with a throttle pedal and a continuous variable transmission, or vehicles fitted with two pedals for forward and reverse direction and a hydrostatic transmission),
 - (c) vehicles of category C with a maximum design speed of less than 15 km/h and fitted with hand-operated levers for controlling differential steering.
- (c) point 2.1 is replaced by the following:
- 2.1. The symbols used for identification of control devices shall comply with the requirements set out in section 1 of Annex XXVI.
- (d) point 3.1.1 is replaced by the following:
- 3.1.1. In the case of a vehicle fitted with hydrostatic transmission or a transmission with a hydrostatic component, the requirement laid down in point 3.1 that the engine cannot be started unless the clutch mechanism is disengaged shall be construed as that the engine cannot be started unless the transmission control is in neutral position or depressurized.
- (e) point 3.2 is replaced by the following:
- 3.2. In case that an operator standing on the ground (e.g. tractor's side), can start the engine and fulfil simultaneously the requirements guaranteeing the safe start of the engine in accordance with point 3.1, one additional control device shall be activated to start the engine.
- (f) the following point 3.3 is inserted:
- 3.3. The terminals of the starter motor shall be protected in order to prevent shunting its solenoid by means of simple tools (e.g. a screwdriver).
- (g) point 7.3 is replaced by the following:
- 7.3. It shall always be possible to shut off the PTO from the driving position. This requirement shall also apply to the associated PTO external control device(s), if fitted. The shut off shall be always an override control device.
- (h) point 7.4 is replaced by the following:
- 7.4. Additional requirements for the PTO external control device(s), if fitted;
- (i) the following point 12 is added:
- 12. **Virtual terminals**

Changes to legislation: There are currently no known outstanding effects for the Commission Delegated Regulation (EU) 2016/1788. (See end of Document for details)

Control devices related to virtual terminals shall meet the requirements set out in Annex B of ISO 15077:2008.

- (15) Annex XXIV is amended as follows:
- (a) point 1.3 is replaced by the following:
 - 1.3. Flexible hydraulic hoses must be clearly identifiable and indelibly marked in accordance with the requirements set out in paragraph 13 of ISO 17165-1:2007.
 - (b) point 4.2 is replaced by the following:
 - 4.2. Greasing points shall be clearly identified on the vehicle with symbols, pictorials, pictograms or colour coding and its location and instructions of use shall be indicated in the operator's manual.
- (16) Annex XXVI is amended as follows:
- (a) section 3 is replaced by the following:
 - 3. **Hydraulic couplings**
 - Hydraulic valves and the couplers on the hydraulic valves at the rear, front or sides of tractors, as well as the flow direction and the mode of operation, shall be identified by colour coding and/or numerals to be stated on durable labels resistant to oil, fuel, wear and chemical agents, such as fertilizers; its location, identification and instructions of use shall be indicated in the operator's manual.
 - (b) section 5 is replaced by the following:
 - 5. **Additional warning signals with regard to braking**
 - Tractors shall be equipped with optical brake failure and defect warning signals, in accordance with points 2.2.1.29.1.1 to 2.2.1.29.2.1 of Annex I to Commission Delegated Regulation (EU) 2015/68⁽¹³⁾
- (17) in Annex XXIX, section 2 is replaced by the following:
- 2. **Requirements for the cabin**
 - 2.1. Vehicles of categories T and C fitted with a cab shall comply with the standard EN 15695-1:2009.
 - 2.2. Vehicles of categories T and C, declared by the manufacturer to provide protection against hazardous substances shall be fitted with a cab of level 2, 3 or 4 according to the definition and complying with the requirements set out in the standard EN 15695-1:2009 (e.g. for a vehicle providing protection against plant protection products that produce vapours which can expose the operator to a risk or harm, the cabin shall be of level 4).

ANNEX III

Annexes I to IV to Delegated Regulation (EU) 2015/96 are amended as follows:

*Changes to legislation: There are currently no known outstanding effects for the
Commission Delegated Regulation (EU) 2016/1788. (See end of Document for details)*

- (1) Annex I is amended as follows:
- (a) points 2.2 and 2.3 are replaced by the following:
- 2.2. The application for type-approval shall be accompanied by the information folder in accordance with Articles 2 and 6 of Implementing Regulation (EU) 2015/504.
- 2.3. An engine conforming to the engine type or parent engine characteristics described in Annexes I and II to Directive 97/68/EC shall be submitted to the technical service responsible for conducting the approval tests.
- (b) in section 4, the third paragraph is replaced by the following:
- Type-approval information documents shall be in accordance with Article 2 of Implementing Regulation (EU) 2015/504.
- (c) section 6 is replaced by the following:
- 6. Conformity of production**
- In addition to the provisions in Article 28 of Regulation (EU) No 167/2013, Article 7 of Delegated Regulation (EU) No 1322/2014 and Annex IV to Delegated Regulation (EU) No 1322/2014 the conformity of production of engines shall be checked in accordance with the provisions of section 5 of Annex I to Directive 97/68/EC.
- (d) section 8 is replaced by the following:
- 8. Market surveillance**
- Having regard to Article 7 of Regulation (EU) No 167/2013, market surveillance shall be performed in accordance with Articles 4, 6 and 10 of Implementing Regulation (EU) 2015/504 and Annexes III, V and IX to Implementing Regulation (EU) 2015/504.
- (e) the Appendix is amended as follows:
- (i) in section 1, point (c) is replaced by the following:
- (c) the EU type-approval mark in accordance with Article 5 of Implementing Regulation (EU) 2015/504.
- (ii) point 6 is replaced by the following:
6. The exact location of the engine marks shall be declared in the information document, in accordance with Article 2 of Implementing Regulation (EU) 2015/504.
- (2) Annex II is amended as follows:
- (a) points 2.1.2 and 2.1.3 are replaced by the following:
- 2.1.2. It shall be accompanied by the information document, in accordance with Article 2 of Implementing Regulation (EU) 2015/504.

Changes to legislation: There are currently no known outstanding effects for the Commission Delegated Regulation (EU) 2016/1788. (See end of Document for details)

2.1.3. The manufacturer shall submit an agricultural and forestry vehicle engine conforming to the engine type or parent engine characteristics in accordance with Annex I to this Regulation and Annex II to Directive 97/68/EC to the technical service responsible for conducting the approval tests.

(b) point 2.2.2 is replaced by the following:

2.2.2. It shall be accompanied by the information document in accordance with Article 2 of Implementing Regulation (EU) 2015/504 and a copy of the EU type-approval certificate for the engine or engine family and, if applicable, for systems, components and separate technical units which are installed in the agricultural and forestry vehicle type.

(c) points 3.2.1 and 3.2.2 are replaced by the following:

3.2.1. intake depression shall not exceed the maximum allowable intake depression specified for the type-approved engine;

3.2.2. exhaust back pressure shall not exceed the maximum allowable back pressure specified for the type-approved engine;

(d) the following point 3.2.3 is inserted:

3.2.3. particular conditions for the installation of the engine in the vehicle according to the type-approval certificate of the engine.

(e) section 4 is replaced by the following:

4. **Approval**

Any agricultural and forestry vehicle type fitted with an engine for which an EU type-approval certificate has been issued in accordance with Annex I to this Regulation or an equivalent type-approval certificate, in accordance with Annex IV to this Regulation, shall be issued with an EU type-approval certificate in accordance with Annex V of Implementing Regulation (EU) 2015/504.

(3) Annex III is amended as follows:

(a) point 1.3.1.1 is replaced by the following:

1.3.1.1. The steady speed before approaching line AA shall be three-quarters of the maximum design speed (v_{max}) as declared by the manufacturer which can be attained in the highest gear used for road movement.

(b) in point 1.3.1.2.3, the second sentence is replaced by the following:

Should that result exceed the maximum permissible sound level for the category of agricultural and forestry vehicle tested by at least 1 dB(A), two further measurements shall be made.

(c) in the first paragraph of point 1.3.2.4, the second and third sentences are replaced by the following:

The engine speed shall be recorded in accordance with the provisions of Article 9. The state of loading of the agricultural and forestry vehicle shall also be recorded.

(d) point 1.3.3 is replaced by the following:

1.3.3. External sound testing provisions for C-category vehicles with track chains in motion

For agricultural and forestry vehicles of C category equipped with track chains, the noise in motion shall be measured with vehicles with their unladen mass in running order travelling at a constant speed of 5 km/h (+/- 0,5 km/h), with the engine at rated speed over a layer of humid sand as specified by paragraph 5.3.2 of ISO 6395:2008. The microphone shall be situated in accordance with the provisions of point 1.3.1. The measured noise value shall be recorded in the test report.

(4) Annex IV is replaced by the following:

ANNEX IV

Recognition of alternative type-approvals

The following type-approvals and, where applicable, the approval marks are recognised as being equivalent to an approval under this Regulation:

1. for engine categories H, I, J and K (stage IIIA) specified in Article 9(3a) and (3b) of Directive 97/68/EC,
 - 1.1. type-approvals in accordance with points 3.1, 3.2 and 3.3 of Annex XII to Directive 97/68/EC;
 - 1.2. Stage IIIA type-approvals in accordance with Directive 97/68/EC;
2. for engine categories L, M, N and P (stage IIIB) specified in Article 9(3c) of Directive 97/68/EC,
 - 2.1. type-approvals in accordance with points 4.1, 4.2 and 4.3 of Annex XII to Directive 97/68/EC;
 - 2.2. Stage IIIB type-approvals in accordance with Directive 97/68/EC;
3. for engine categories Q and R (stage IV) specified in Article 9(3d) of Directive 97/68/EC,
 - 3.1. type-approvals in accordance with points 5.1 and 5.2 of Annex XII to Directive 97/68/EC.
 - 3.2. Stage IV type-approvals in accordance with Directive 97/68/EC;
 - 3.3. type-approvals in accordance with the 04 series of amendments of UNECE Regulation No 96 for power bands Q and R of paragraph 5.2.1 in that UN Regulation.

Changes to legislation: There are currently no known outstanding effects for the Commission Delegated Regulation (EU) 2016/1788. (See end of Document for details)

ANNEX IV

Annexes I to V, VII, VIII, IX, XI, XII and XIII to Delegated Regulation (EU) 2015/68 are amended as follows:

- (1) Annex I is amended as follows:
 - (a) points 1.3, 1.4 and 1.5 are deleted;
 - (b) point 2.1.1 is replaced by the following:
 - 2.1.1. Braking components and parts
 - (c) points 2.1.1.1 and 2.1.1.2 are replaced by the following:
 - 2.1.1.1. The braking components and parts shall be so designed, constructed and fitted as to enable the vehicle in normal use, despite the vibration to which it may be subjected, to comply with the requirements set out in this Annex.
 - 2.1.1.2. In particular, the braking components and parts shall be so designed, constructed and fitted as to be able to resist the corrosion and ageing phenomena to which it is exposed.
 - (d) point 2.1.1.4 is replaced by the following:
 - 2.1.1.4. It is not permitted to fit any adjustable valves that would allow the performance of the braking system to be changed by the user of the vehicle such that, in service, it is not subject to the requirements of this Regulation. An adjustable valve that can only be operated by the manufacturer through the use of special tools or the provision of a tamper proof seal shall be permitted provided that the user of the vehicle is not able to adjust this valve or that any user adjustment is readily identifiable by enforcement authorities.
 - (e) points 2.1.1.5.1, 2.1.1.5.2 and 2.1.1.5.3 are replaced by the following:
 - 2.1.1.5.1. If vehicles of category Ra with a maximum design speed not exceeding 30 km/h and vehicles of category Sa cannot be equipped for technical reasons with an automatic load sensing device, they may be equipped with a device having at least three discrete settings for the control of the braking forces.
 - 2.1.1.5.2. In the special case that a towed vehicle of category Ra with a maximum design speed not exceeding 30 km/h and vehicles of category Sa allows by design that only two discrete loading conditions 'unladen' and 'laden' can be realized then the vehicle may have only two discrete settings for the control of the braking forces.
 - 2.1.1.5.3. S-category vehicles which do not contain any other load, except a payload from consumable material of maximum 10 % of the sum of technically permissible masses per axle.
 - (f) point 2.1.2.3 is replaced by the following:
 - 2.1.2.3. Parking braking system

Changes to legislation: There are currently no known outstanding effects for the Commission Delegated Regulation (EU) 2016/1788. (See end of Document for details)

The parking braking system shall enable the vehicle to be held stationary on an up or down gradient even in the absence of the driver, the working parts of the braking system being then held in the locked position by a purely mechanical device. The driver shall be able to achieve this braking action from his driving seat, subject, in the case of a towed vehicle, to the requirements of point 2.2.2.10.

The towed vehicle service braking system (pneumatic or hydraulic) and the parking braking system of the tractor may be operated simultaneously, provided that the driver is able to check, at any time, that the parking braking system performance of the vehicle combination, obtained by the purely mechanical action of the tractor's parking braking system, is sufficient.

- (g) in the first paragraph of point 2.1.5.1.3, the first sentence is deleted;
- (h) point 2.1.8.1.2 is replaced by the following:

2.1.8.1.2. In a braking system which incorporates a device that modulates the air pressure in the brake transmission as referred to in point 6.2 of Appendix I to Annex II, located in the pressure line upstream and downstream of this device at the closest accessible position. If this device is pneumatically controlled an additional test connection is required to simulate the laden condition. Where no such device is fitted, a single pressure test connection, equivalent to the downstream connector mentioned in point 2.1.5.1 of this Annex, shall be provided. These test connections shall be so located as to be easily accessible from the ground or within the vehicle.
- (i) in point 2.2.1.1, the third paragraph is replaced by the following:

For category Tb tractors: if the differential braking function is activated, it shall not be possible to travel at speeds exceeding 40 km/h or at speeds in excess of 40 km/h the differential braking function shall be disabled. These two operations shall be ensured by automatic means.
- (j) point 2.2.1.2.6.1 is replaced by the following:

2.2.1.2.6.1. Where the service braking system is actuated by the muscular energy of the driver assisted by an energy source or one or more energy reserves, the secondary braking performance shall, in the event of failure of that assistance, be capable of being ensured by the muscular energy of the driver assisted by the energy reserves, if any, which are unaffected by the failure, the force applied to the control device not exceeding the prescribed maxima.
- (k) point 2.2.1.6.1 is replaced by the following:

2.2.1.6.1. Performance of hydraulic lines and hose assemblies in case of vehicles with one braked axle and an automatic engagement of the drive to all other axles during braking

The hydraulic lines of hydraulic transmission shall be capable of a burst pressure at least four times the maximum normal service pressure (T) specified by the vehicle manufacturer. Hose assemblies shall comply with ISO Standards 1402:2009, 6605:2002 and 7751: 1997+A1:2011.

Changes to legislation: There are currently no known outstanding effects for the Commission Delegated Regulation (EU) 2016/1788. (See end of Document for details)

- (l) in point 2.2.1.7, the second sentence is deleted.
- (m) in the first paragraph of point 2.2.1.10, the first sentence is replaced by the following:

It shall be possible for the wear of the service brakes to be compensated by means of a system of manual or automatic adjustment.
- (n) in the first paragraph of point 2.2.1.10.1, the first sentence is replaced by the following:

Automatic wear adjustment devices, if fitted, shall, after heating followed by cooling, be capable of free running as laid down in point 2.3.4 of Annex II following the Type-I test specified in point 2.3 of that Annex.
- (o) in point 2.2.1.11.1, the following second paragraph is added:

In hydraulic braking systems, where the type of fluid used for hydraulic transmission is common with the fluid used in other appliances of the vehicle in a common tank, it is also permitted to detect the correct level of fluid with a device which needs the container to be opened.
- (p) in point 2.2.1.11.2, the following second paragraph is added:

In hydraulic braking systems, where the type of fluid used for hydraulic transmission is common with the fluid used in other appliances of the vehicle in a common tank, detection of a pressure drop in the hydraulic transmission to a certain value as specified by the manufacturer is also permitted.
- (q) in point 2.2.1.11.3, the second sentence is replaced by the following:

The symbol shall be affixed within 100 mm of the filling ports of the fluid reservoirs, in accordance with the requirements laid down in Article 24 of Delegated Regulation (EU) 2015/208.
- (r) point 2.2.1.13 is replaced by the following:

2.2.1.13. Tractors of category Tb with maximum design speed exceeding 60 km/h

Without prejudice to the requirements of point 2.1.2.3, where the use of an auxiliary energy source is essential for the operation of a braking system, the energy reserve shall be such as to ensure that, should the engine stop, or in the event of a failure of the means by which the energy source is driven, the braking performance remains sufficient to bring the vehicle to a halt in the prescribed conditions. In addition, if the muscular energy applied by the driver to the parking braking system is reinforced by some aid, the actuation of the parking braking system shall be ensured in the event of failure of that aid, if necessary by using a reserve of energy independent of that normally supplying such aid. This reserve of energy may be that intended for the service braking system.
- (s) point 2.2.1.17.3 is replaced by the following:

2.2.1.17.3. In the event of a failure in one of the control lines connecting two vehicles equipped according to point 2.1.4.1.2 of this Annex, the

control line not affected by the failure shall automatically ensure the braking performance prescribed for the towed vehicle in point 3.2.1 of Annex II.

- (t) point 2.2.1.18.6 is replaced by the following:
- 2.2.1.18.6 In the case of a failure (e.g. fracture or leak) in the control line, the pressure in the supplementary line shall fall to 1 000 kPa within the following two seconds after the service brake control device has been fully actuated. In addition, when the service brake control device is released, the supplementary line shall be re-pressurised (see also point 2.2.2.15.2).
- (u) in point 2.2.1.18.9, the first sentence is replaced by the following:
- Tractors towing vehicles of categories R or S which can only comply with the braking performance requirements of the service braking system, parking braking system or automatic braking system with the assistance of energy stored in a hydraulic energy storage device shall be equipped with an ISO 7638:2003 connector in order to be able to indicate the low level of stored energy on the towed vehicle, received by the latter, as laid down in point 2.2.2.15.1.1 by the separate warning signal via pin 5 of the electrical connector conforming to ISO 7638:2003 specified in point 2.2.1.29.2.2. (see also point 2.2.2.15.1).
- (v) point 2.2.1.20 is replaced by the following:
- 2.2.1.20. If point 3.1.3.4 of Annex II can only be fulfilled by complying with the conditions specified in point 3.1.3.4.1.1 of Annex II then:
- (w) point 2.2.1.25.1 is deleted;
- (x) point 2.2.1.26.1.2 is replaced by the following:
- 2.2.1.26.1.2 In the case of an electrical failure in the control device or a break in the wiring within the electric control transmission external to the electronic control unit(s), excluding the energy supply, it shall remain possible to apply the parking braking system from the driver's seat and thereby be capable of holding the laden vehicle stationary on an 8 % up or down gradient.
- (y) point 2.2.1.26.3 is replaced by the following:
- 2.2.1.26.3 Alternatively to the parking brake performance requirements according to points 2.2.1.26.1.2 and 2.2.1.26.2.1.2, the alternatives set out in points 2.2.1.26.3.1 and 2.2.1.26.3.2 are also allowed.
- 2.2.1.26.3.1 automatic actuation of the parking braking system is allowed when the vehicle is stationary, provided that the performance referred to in points 2.2.1.26.1.2 and 2.2.1.26.2.1.2 is achieved and, once applied, the parking braking system remains engaged independently of the status of the ignition (start) switch. In this alternative, the parking braking system shall be automatically released as soon as the driver starts to set the vehicle in motion again.

Changes to legislation: There are currently no known outstanding effects for the Commission Delegated Regulation (EU) 2016/1788. (See end of Document for details)

2.2.1.26.3 ~~ap~~ Applying the brakes of the parking braking system from the driver's seat by an auxiliary control device and thereby be capable of holding the laden vehicle stationary on an 8 % up or down gradient. In this case, also the requirements of point 2.2.1.26.7 shall be met.

(z) in point 2.2.1.26.5, the third paragraph is replaced by the following:

Where actuation of the parking braking system is normally indicated by a separate warning signal, satisfying all the requirements of 2.2.1.29.4 this signal shall be used to satisfy the requirement for a red signal set out in the first and the second paragraphs of this point.

(aa) points 2.2.1.29.1.1 and 2.2.1.29.1.2 are replaced by the following:

2.2.1.29.1A red warning signal, in accordance with the requirements laid down in Annex XXVI of Delegated Regulation (EU) No 1322/2014 indicating failures within the vehicle braking equipment, as specified in other points of this Annex and in Annexes V, VII, IX and XIII, which preclude achievement of the prescribed service braking performance or the functioning of at least one of two independent service braking circuits.

2.2.1.29.1 ~~W~~Where applicable, a yellow warning signal, in accordance with the requirements laid down in Article 29 of Delegated Regulation (EU) No 1322/2014 indicating an electrically detected defect within the vehicle braking equipment, which is not indicated by the warning signal mentioned in point 2.2.1.29.1.1.

(bb) in point 2.2.1.29.2, the first sentence is replaced by the following:

Tractors equipped with an electric control line and/or authorized to tow a vehicle equipped with an electric control transmission, shall be capable of providing a separate warning signal, in accordance with the requirements laid down in Article 29 of Delegated Regulation (EU) No 1322/2014 to indicate a defect within the electric control transmission of the braking equipment of the towed vehicle.

(cc) in point 2.2.1.29.2.1, the third sentence is replaced by the following:

Alternatively, instead of utilizing the warning signal specified in point 2.2.1.29.1.1 of this Annex and the accompanying warning signal referred to in this point, a separate red warning signal, in accordance with the requirements laid down in Article 29 of Delegated Regulation (EU) No 1322/2014, may be provided in the tractor to indicate such a failure within the braking equipment of the towed vehicle.

(dd) in point 2.2.2.1, the first sentence is replaced by the following:

Vehicles of categories R1a, S1a do not need to be fitted with a service braking system. Vehicles of categories R1b and S1b, where the sum of the technically permissible masses per axle does not exceed 750 kg, do not need to be fitted with a service braking system.

(ee) in point 2.2.2.2, the first sentence is replaced by the following:

Vehicles of categories R1b and S1b, where the sum of the technically permissible masses per axle exceeds 750 kg, and R2 shall be equipped with a service braking system either of the continuous or semi-continuous or of the inertia type.

(ff) point 2.2.2.3.1.3 is deleted;

(gg) in point 2.2.2.15.1.1, the first paragraph is replaced by the following:

When the pressure in the hydraulic energy storage devices falls below a pressure declared by the vehicle manufacturer in the information folder where the prescribed braking performance(s) is (are) not ensured this low pressure shall be indicated to the driver by the separate warning signal specified in point 2.2.1.29.2.2 via pin 5 of the electrical connector conforming to ISO 7638:2003.

(hh) in point 2.2.2.18, the first sentence of the second paragraph is replaced by the following:

Those vehicles shall be marked in indelible form, in accordance with the requirements laid down in Article 24 of Delegated Regulation (EU) 2015/208, to indicate the functionality of the braking system when the ISO 7638:2003 connector is connected and disconnected.

(2) Annex II is amended as follows:

(a) point 1.2 is replaced by the following:

1.2. 'adhesion utilization curve' means the characteristic curve of the braking force ratio without rolling resistance and normal reaction of road surface on a given axle under braking plotted against the braking rate of the vehicle.

(b) in point 2.1.4.2, the second paragraph is replaced by the following:

The behaviour of vehicles of categories Tb, R2b, R3b, R4b and S2b on a road on which adhesion is reduced, shall meet the relevant requirements of Appendix 1 of this Annex or, if the vehicle is equipped with ABS, the requirements of Annex XI.

(c) point 2.2.2.2 is replaced by the following:

2.2.2.2. To check compliance with the requirements of point 2.2.1.2.4 of Annex I, a Type-0 test shall be carried out with the engine disconnected at the initial speed of 30 km/h.

On application of the control of the parking brake system, the mean fully developed deceleration and the deceleration immediately before the vehicle stops shall not be less than 1,5 m/s². The same requirement applies in case of auxiliary control mentioned in point 2.2.1.2.4 of Annex I.

The test shall be carried out with the laden vehicle. The force exerted on the braking control device shall not exceed the specified values.

(d) in point 2.3.1.4, the following sentence is added:

Changes to legislation: There are currently no known outstanding effects for the Commission Delegated Regulation (EU) 2016/1788. (See end of Document for details)

As an alternative, it is also allowed to perform the test with the engine disconnected, where applicable, during brake applications.

- (e) point 2.3.2.1 is replaced by the following:
- 2.3.2.1. The service braking system of vehicles of categories R1, R2, S1, R3a, R4a and S2a; and of vehicles of categories R3b and S2b, where the sum of the technically permissible masses per axle does not exceed 10 000 kg, shall be tested in such a manner that, the vehicle being laden, the energy input to the brakes is equivalent to that recorded in the same period of time when the laden vehicle being tested is driven at a steady speed of 40 km/h on a 7 % down-gradient for a distance of 1,7 km.
- Alternatively, this requirement is deemed to be fulfilled for vehicles of categories R3a, R4a, S2a and for vehicles of categories R3b and S2b, where the sum of the technically permissible masses per axle does not exceed 10 000 kg, when these vehicles have passed the Type-III test according to point 2.5.
- (f) point 2.3.4.2 is replaced by the following:
- 2.3.4.2. It is ascertained that when the vehicle is driven at a constant speed of $v = 60$ km/h or the maximum design speed of the towed vehicle, whichever is the lower, with the brakes released the asymptotic temperatures shall not exceed a drum/disc temperature increase of 80°C, then the residual brake moments are regarded as acceptable.
- (g) point 2.5.3 is replaced by the following:
- 2.5.3. R3b and S2b where the sum of the technically permissible masses per axle does not exceed 10 000 kg.
- (h) point 3.1.1.2 is amended as follows:
- (i) the first paragraph is replaced by the following:
- In the case of a tractor authorized to tow an unbraked vehicle of categories R or S, the required minimum combination performance, as required in point 3.1.1.2.1, shall be attained with the unbraked towed vehicle coupled to the tractor and with the unbraked towed vehicle laden to the maximum mass declared by the tractor manufacturer.
- (ii) the last sentence in the third paragraph is replaced by the following:
- $$P_{M+R} = \text{combination mass (mass } P_M + \text{ declared unbraked towed vehicle mass } P_R)$$
- (i) in the second paragraph of point 3.1.3.3, the following indent is added:
- During the cooling period, the parking braking system shall not be re-adjusted manually.
- (j) in point 3.1.3.3, the following fourth paragraph is added:

Changes to legislation: There are currently no known outstanding effects for the
Commission Delegated Regulation (EU) 2016/1788. (See end of Document for details)

The hot static parking braking system test may be omitted if the parking braking system acts purely on braking surfaces not used during service braking.

- (k) in point 3.1.3.4, the second paragraph is replaced by the following:

In the case that this requirement cannot be met due to physical limitations (e.g. limited available tyre/road adhesion for the tractor to generate sufficient braking forces or in the case that the purely mechanical parking braking system performance of the tractor as prescribed in point 3.1.3.1 is not sufficient to hold the combination) it is deemed to be fulfilled when the alternative requirement set out in point 3.1.3.4.1 of this Annex in connection with point 2.2.1.20 of Annex I is complied with.

- (l) points 3.1.3.4.1, 3.1.3.4.1.1 and 3.1.3.4.1.2 are replaced by the following:

3.1.3.4.1. The requirement of point 3.1.3.4 is considered to be fulfilled when the conditions set out in point 3.1.3.4.1.1 are met in the case of a towed vehicle with service brake, or when the conditions set out in point 3.1.3.4.1.2 are met in the case of an unbraked or inertia-braked towed vehicle.

3.1.3.4.1.1. Even with the tractor engine not rotating, the combination at the maximum permissible mass remains stationary on the prescribed gradient when the activation of a single control device by the driver, from his driving seat, has applied the tractor parking braking system and the towed vehicle service braking system or only the tractor parking braking system.

3.1.3.4.1.2. The tractor parking braking system can hold stationary the tractor connected to an unbraked or inertia-braked towed vehicle having a mass equal to the highest 'combination mass P_{M+R} ' mentioned in the test report. This mass shall be determined as follows:

- (a) in the case of unbraked towed vehicle: P_{M+R} = combination mass (mass P_M + declared unbraked towed vehicle mass P_R) according to point 3.1.1.2;
- (b) in the case of an inertia braked towed vehicle: P_{M+R} = combination mass (mass P_M + declared inertia-braked towed vehicle mass as specified by the manufacturer).

P_M = mass of the tractor (if applicable, including any ballast or supporting load or both of them).

- (m) in point 3.2.1.3, the fifth paragraph is replaced by the following:

The test speed is 60 km/h or the maximum design speed of the towed vehicle, whichever is the lower.

- (n) point 3.2.3 is replaced by the following:

3.2.3. Automatic braking system

The automatic braking performance in the event of a failure, as described in points 2.2.1.17.1 and 2.2.1.18.5 of Annex I, when testing the laden vehicle

Changes to legislation: There are currently no known outstanding effects for the Commission Delegated Regulation (EU) 2016/1788. (See end of Document for details)

from a speed of 40 km/h or 0,8 v_{max} (whichever is lower), shall not be less than 13,5 % of the maximum stationary wheel load. Wheel-locking at performance levels above 13,5 % is permitted.

(o) Appendix 1 is amended as follows:

(i) point 1.1.3 is replaced by the following:

1.1.3. However, vehicles of the categories mentioned in point 1.1.1 and in point 1.1.2 both equipped with an anti-lock braking system of category 1 or 2 (tractors) and category A or B (towed vehicles) fulfilling the relevant requirements of Annex XI shall also fulfil all the relevant requirements of this Appendix with the following exceptions or conditions:

(ii) the following points 1.1.5 and 1.1.6 are inserted:

1.1.5. The requirements of this Appendix apply to the braking equipment fitted with the largest diameter tyres intended by the manufacturer for that vehicle type.

1.1.6. Compliance with the adhesion utilisation and compatibility requirements associated with diagrams 1, 2 and 3 of this Appendix shall be demonstrated by calculation.

(iii) section 3 is replaced by the following:

3. Requirements for tractors of category T

3.1. Two-axle tractors

3.1.1. For k values between 0,2 and 0,8:

$$z \geq 0,10 + 0,85 (k - 0,20)$$

The provisions laid down in this point do not affect the requirements of Annex II relating to the braking performance. However, if, in tests made under the provisions of this point, braking performances are obtained which are higher than those prescribed in Annex II, the provisions relating to the adhesion utilization curves shall be applied within the areas of diagram 1 defined by the straight lines $k = 0,8$ and $z = 0,8$.

3.1.2. For all braking rates between 0,15 and 0,30:

3.1.2.1. The adhesion utilization curves for each axle are situated between two lines parallel to the line of ideal adhesion utilization given by the equation $k = z \pm 0,08$ as shown in diagram 1 and the adhesion utilization curve for the rear axle for braking rates $z > 0,3$ complies with the relation:

$$z \geq 0,3 + 0,74 (k - 0,38).$$

3.1.3. For tractors authorised to tow vehicles of category R3b, R4b and S2b fitted with compressed-air braking systems:

- 3.1.3.1. When tested with the energy source stopped, the supply line blocked off, a reservoir of 0,5 litre capacity connected to the pneumatic control line and the system at cut-in and cut-out pressures, the pressure at full application of the braking control device shall be between 650 and 850 kPa at the coupling heads of the supply line and the pneumatic control line, irrespective of the load condition of the vehicle.
- 3.1.3.2. For vehicles equipped with an electric control line, a full application of the control device of the service braking system shall provide a digital demand value corresponding to a pressure between 650 and 850 kPa (see ISO 11992:2003 including ISO 11992-2:2003 and its Amd.1:2007).
- 3.1.3.3. These values shall be demonstrably present in the tractor when the latter is uncoupled from the towed vehicle. The compatibility bands in the diagrams specified in points 3.1.6, 4.1 and 4.2, should not be extended beyond 750 kPa and/or the corresponding digital demand value (see ISO 11992:2003 including ISO 11992-2:2003 and its Amd.1:2007).
- 3.1.3.4. It shall be ensured that at the coupling head of the supply line, a pressure of at least 700 kPa is available when the system is at cut-in pressure. This pressure shall be demonstrated without applying the service brakes.
- 3.1.4. For tractors authorised to tow vehicles of category R3b, R4b and S2b fitted with hydraulic braking systems:
- 3.1.4.1. When tested with the energy source at idling speed and of 2/3 of maximum engine speed, a control line of the towed vehicle simulator (point 3.6 of Annex III) connected to the hydraulic control line. At full application of the braking control device the pressures shall be between 11 500 and 15 000 kPa at the hydraulic control and shall be between 1 500 and 3 500 kPa at the supplementary line, irrespective of the load condition of the vehicle.
- 3.1.4.2. These values shall be demonstrably present in the tractor when uncoupled from the towed vehicle. The compatibility bands in the diagrams specified in points 3.1.6, 4.1 and 4.2, should not be extended beyond 13 300 kPa.
- 3.1.5. Verification of the requirements of points 3.1.1 and 3.1.2
- 3.1.5.1. In order to verify the requirements of points 3.1.1 and 3.1.2, the manufacturer shall provide the adhesion utilisation curves for the front and rear axles calculated by the formulae:

$$f_1 = \frac{T_1}{N_1} = \frac{T_1}{F_1 + z \times \frac{h}{R} \times P \times g}$$

Changes to legislation: There are currently no known outstanding effects for the Commission Delegated Regulation (EU) 2016/1788. (See end of Document for details)

$$\Omega = \frac{T_2}{N_2} = \frac{T_2}{F_2 - z \times \frac{h}{r} \times P \times g}$$

The curves shall be plotted for both the following load conditions:

3.1.5.1.1. Unladen, not exceeding the minimum mass declared by the manufacturer in the information document;

3.1.5.1.2. Laden; where provision is made for several possibilities of load distribution, the one whereby the front axle is the most heavily laden shall be the one considered.

3.1.5.2. Special requirements in the case of tractors where all axles are permanently rigidly connected (100 % locking rate) by the all-wheel drive or are automatically connected during braking by the all-wheel drive (100 % locking rate)

3.1.5.2.1. The mathematical verification pursuant to point 3.1.5.1 is not required.

3.1.5.3. Tractors with permanent all-wheel drive other than covered by point 3.1.5.2.

3.1.5.3.1. If it is not possible, for vehicles with permanent all-wheel drive or in the condition when the all-wheel drive is connected during braking, to carry out the mathematical verification pursuant to point 3.1.5.1, the manufacturer may instead verify by means of a wheel lock sequence test that, lockup of the front wheels occurs either simultaneously with or before the lockup of the rear wheels.

3.1.5.4. However, for tractors which automatically apply the all-wheel drive when the braking is initiated above a vehicle speed of 20 km/h but not automatically connect the all-wheel drive when the service braking system is applied at speeds not exceeding 20 km/h, then it is not required to show compliance with point 3.1.5.1 for the condition when the all-wheel drive is not connected during braking.

3.1.5.5. Procedure to verify the requirements set out in point 3.1.5.3

3.1.5.5.1. The wheel lock sequence test shall be conducted with the laden and the unladen vehicle on road surfaces having an adhesion level such that wheel locking on the first axle occurs at braking rates between 0,55 and 0,8 from the initial test speed specified in point 3.1.5.5.2.

3.1.5.5.2. Test speed:

0,9 v_{max}, but not exceeding 60 km/h.

3.1.5.5.3. The pedal force applied may exceed the permissible actuation forces pursuant to point 3.1.1 of Annex II.

3.1.5.5.4. Pedal force is applied and increased such that the second wheel on the vehicle shall reach lockup between 0,5 and 1 s after initiating the brake application, until lockup of both wheels on one axle occurs (additional wheels may also lock during the test, e.g. in the case of simultaneous lockup).

3.1.5.5.4. If it is not possible during the laden test to reach lockup of the second wheel within a period of 1 s, this test may be omitted under the condition that wheel-locking under the conditions as prescribed in point 3.1.5.5.4 can be demonstrated during the unladen test.

If also in the unladen test it is not possible to reach lockup of the second wheel within a period of 1 s, a third, decisive test shall be carried out on road surfaces with a coefficient of adhesion of not more than 0,3 from a test speed of 0,8 v_{max} km/h, but not exceeding 60 km/h.

3.1.5.5.4. For the purpose of the tests according to point 3.1.5.5, a simultaneous lockup of the front and rear wheels refers to the conditions when the time interval between the first occurrence of lockup of the last (second) wheel on the rear axle and the first occurrence of lockup of the last (second) wheel on the front axle does not exceed 0,3 second.

3.1.6. Tractors authorized to draw towed vehicles

3.1.6.1. The permissible relationship between the braking rate T_M/F_M and the pressure p_m shall lie within the areas shown on diagram 2 for all pressures between 20 and 750 kPa (in the case of compressed air braking system) and 350 and 13 300 kPa (in the case of hydraulic braking system).

3.2. Tractors with more than two axles

The requirements of point 3.1 shall apply to vehicles with more than two axles. The requirements of point 3.1.2 with respect to wheel lock sequence shall be considered to be met if, in the case of braking rates between 0,15 and 0,30, the adhesion utilised by at least one of the front axles is greater than that utilised by at least one of the rear axles.

(iv) point 6.1 is replaced by the following:

6.1. Vehicles which meet the requirements of this Appendix by means of a device mechanically controlled by the suspension of the vehicle shall be marked in accordance with the requirements laid down in Article 24 of Delegated Regulation (EU) 2015/208 and with the appropriate data to show the useful travel of the device between the positions corresponding to vehicle unladen and laden states, respectively, and any further

Changes to legislation: There are currently no known outstanding effects for the Commission Delegated Regulation (EU) 2016/1788. (See end of Document for details)

information to enable the setting of the device to be checked.

- (v) in point 6.3, the second sentence is replaced by the following:

An example of the markings for a mechanically controlled device in a vehicle fitted with compressed-air or hydraulic braking system is provided in accordance with the requirements laid down in Article 5 of Commission Implementing Regulation (EU) 2015/504⁽¹⁴⁾.

- (vi) the title of Diagram 2 is replaced by the following:
Permissible relationship between braking rate T_M/F_M and the coupling head pressure p_m for tractors of categories T and C with compressed air or hydraulic braking systems

- (3) Annex III is amended as follows:

- (a) point 3.6.2.1.2.1 is deleted;
- (b) in point 1.1 of Appendix 2, the description of symbol A is replaced by the following:

A = hydraulic accumulator (pre-charge pressure: 1 000 kPa)

- (4) Annex IV is amended as follows:

- (a) in point 1.2.2.1 of part A, the third sentence is replaced by the following:
The initial pressure shall be stated in the information folder.
- (b) part B is amended as follows:
- (i) in point 1.2.2.1, the third sentence is replaced by the following:
The initial energy level shall be stated in the information folder.
- (ii) in point 1.3.2.1, the third sentence is replaced by the following:
The initial energy level shall be stated in the information folder.
- (c) part C is amended as follows:
- (i) in point 1.1.1, the following paragraph is added:
Energy storage devices used as pulsation dampers in hydraulic braking systems where the prescribed service braking performance is achieved by an energy source, are not considered as energy accumulation devices in the sense of this Annex.
- (ii) point 2.1.3 is replaced by the following:
2.1.3. Interpretation of results
The time t shall not exceed 30 s in the case of tractors to which the coupling of a towed vehicle is not authorised.

- (5) in Annex V, point 2.2.1 is replaced by the following:

- 2.2.1. response time requirements as laid down in section 6 of Annex III;

(6) Annex VII is amended as follows:

- (a) the title is replaced by the following:
Alternative test requirements for vehicles for which tests equivalent to Type-I, Type-II or Type-III tests have been carried out
- (b) sections 1 and 2 are replaced by the following:

1. **Definitions**

For the purposes of this Annex:

- 1.1. 'subject towed vehicle' means a towed vehicle representative of the towed vehicle type for which type-approval is sought;
- 1.2. 'identical' means parts having identical geometric and mechanical characteristics and the materials used for the components of the vehicles;
- 1.3. 'reference axle' means an axle for which there is a test report;
- 1.4. 'reference brake' means a brake for which there is a test report;
- 1.5. 'nominal test mass' means the mass of a disc or drum which the manufacturer specifies for the disc or drum, respectively, with which the relevant test is carried out by the Technical Service;
- 1.6. 'actual test mass' means the mass measured by the Technical Service prior to the test;
- 1.7. 'brake input threshold torque' means the input torque necessary to produce a measurable brake torque;
- 1.8. 'declared brake input threshold torque' means the brake input threshold torque declared by the manufacturer and which is representative for the brake;
- 1.9. 'declared external diameter' means the external diameter of a disc declared by the manufacturer which is representative external diameter for the disc;
- 1.10. 'nominal external diameter' means the external diameter which the manufacturer specifies for the disc on which the relevant test is carried out by the Technical Service;
- 1.11. 'actual external diameter' means the external diameter of a disc measured by the Technical Service prior to the test;
- 1.12. 'effective length of the cam shaft' means the distance from the centre line of the S-cam to the centre line of the operating lever;
- 1.13. 'brake factor' means the input to output amplification ratio of the brake.

2. **General requirements**

Type-I and/or Type-II or Type-III tests, set out in Annex II, need not be performed on a vehicle and its systems submitted for approval in the following cases:

Changes to legislation: There are currently no known outstanding effects for the Commission Delegated Regulation (EU) 2016/1788. (See end of Document for details)

- 2.1. The vehicle concerned is a tractor or a towed vehicle which, as regards tyres, braking energy absorbed per axle, and mode of tyre fitting and brake assembly, is identical with respect to braking with a tractor or a towed vehicle which:
 - 2.1.1. Has passed the Type-I and/or Type-II or Type-III test; and
 - 2.1.2. Has been approved, with regard to the braking energy absorbed, for mass per axle not lower than that of the vehicle concerned.
 - 2.2. The vehicle concerned is a tractor or a towed vehicle whose axle or axles are, as regards tyres, braking energy absorbed per axle, and mode of tyre fitting and brake assembly, identical with respect to braking with an axle or axles which have individually passed the Type-I and/or Type-II or Type-III test for masses per axle not lower than that of the vehicle concerned, provided that the braking energy absorbed per axle does not exceed the energy absorbed per axle in the reference test or tests carried out on the individual axle.
 - 2.3. The vehicle concerned is a tractor equipped with an endurance braking system, other than the engine brake, identical with an endurance braking system already tested under the following conditions:
 - 2.3.1. The endurance braking system shall, by itself, in a test carried out on a gradient of at least 6 per cent (Type-II test), have stabilised a vehicle whose maximum mass at the time of the test was not less than the maximum mass of the vehicle submitted for approval;
 - 2.3.2. It shall be verified in the above test that the rotational speed of the rotating parts of the endurance braking system, when the vehicle submitted for approval reaches a road speed of 30 km/h, is such that the retarding torque is not less than that corresponding to the test referred to in point 2.3.1.
 - 2.4. The vehicle concerned is a towed vehicle equipped with air operated S-cam or disc brakes which satisfy the verification requirements of Appendix 1 relative to the control of characteristics compared to the characteristics given in a report for a reference axle as shown in the test report. Other brake designs from air operated S-cam or disc brakes may be approved upon presentation of equivalent information.
- (c) section 4 is replaced by the following:
4. **Type-approval certificate**
- Where the foregoing requirements are applied, the type approval certificate shall include the following particulars:
- 4.1. In the case under point 2.1 of this Annex, the approval number of the vehicle subjected to the Type-I and/or Type-II or Type-III test of reference shall be entered.

Changes to legislation: There are currently no known outstanding effects for the Commission Delegated Regulation (EU) 2016/1788. (See end of Document for details)

- 4.2. In the cases under point 2.2 of this Annex, Table I in the template set out in Annex V to Implementing Regulation (EU) 2015/504 shall be completed.
- 4.3. In the cases under point 2.3 of this Annex, Table II in the template set out in Annex V to Implementing Regulation (EU) 2015/504 shall be completed.
- 4.4. If point 2.4 of this Annex is applicable, Table III in the template set out in Annex V to Implementing Regulation (EU) 2015/504 shall be completed.
- (d) Appendix 1 is amended as follows:
- (i) section 2 is replaced by the following:
2. **Symbols used in this Annex are explained in the following table:**
- 2.1. Symbols
- | | | |
|-------------|---|--|
| P | = | part of the vehicle mass borne by the axle under static conditions |
| F | = | normal reaction of road surface on the axle under static conditions = $P \cdot g$ |
| F_R | = | total normal static reaction of road surface on all wheels of towed vehicle |
| F_e | = | test axle load |
| P_e | = | F_e / g |
| g | = | acceleration due to gravity: $g = 9.81 \text{ m/s}^2$ |
| C | = | brake input torque |
| C_0 | = | brake input threshold torque. This torque may be determined by extrapolation of measurements within a range not exceeding 15 per cent braking rate or other equivalent methods |
| $C_{0,dec}$ | = | declared brake input threshold torque |
| C_{max} | = | maximum brake input torque |

Changes to legislation: There are currently no known outstanding effects for the Commission Delegated Regulation (EU) 2016/1788. (See end of Document for details)

R	=	dynamic tyre rolling radius. As an alternative for vehicles of categories Ra and Sa, the static loaded radius, as specified by the tyre manufacturer, may be used instead of the dynamic tyre rolling radius
T	=	brake force at tyre/road interface
T _R	=	total brake force at tyre/road interface of the towed vehicle
M	=	brake torque = T.R
z	=	braking rate = T/F or M/(R·F)
s	=	actuator stroke (working stroke plus free stroke)
s _p	=	the effective stroke (the stroke at which the output thrust is 90 % of the average thrust Th _A)
Th _A	=	average thrust (the average thrust is determined by integrating the values between 1/3 and 2/3 of the total stroke S _{max})
l	=	lever length
r	=	internal radius of brake drums or effective radius of brake discs
p	=	brake actuation pressure

Note: Symbols with the suffix ‘e’ relate to the parameters associated with the reference brake test and may be added to other symbols as appropriate.

(ii) point 3.1.2 is replaced by the following:

3.1.2. The results of tests on a combination of axles may be used in accordance with point 2.1 of this Annex provided that each axle contributes equal braking energy input during the drag and hot brake tests.

(iii) point 3.7 is replaced by the following:

3.7. Identification

3.7.1. The axle shall carry in a visible position at least the following identification information grouped together, in any order, in a legible and indelible manner:

3.7.1.1. Axle manufacturer and/or make;

3.7.1.2. Axle identifier;

3.7.1.3. Brake identifier

3.7.1.4. Fe identifier;

3.7.1.5. Base part of test report number;

3.7.1.6. Example of the identifiers:

Axle Manufacturer and/or make ABC

ID1-XXXXXX

ID2-YYYYYY

ID3-11111

ID4-ZZZZZZZ

3.7.2. A non-integrated automatic brake adjustment device shall carry in a visible position at least the following identification information grouped together, in a legible and indelible manner:

3.7.2.1. Manufacturer and make or one of the two, as applicable

3.7.2.2. Type

3.7.2.3. Version

3.7.3. The make and type of each brake lining or pad shall be visible when the lining or pad is mounted on the brake shoe or back plate in a legible and indelible manner.

3.7.4. Identifiers

3.7.4.1. Axle identifier

The axle identifier categorizes an axle in terms of its braking force/torque capability as stated by the axle manufacturer.

The axle identifier shall be an alphanumeric number consisting of the four characters 'ID1-' followed by a maximum of 20 characters.

3.7.4.2. Brake identifier

Changes to legislation: There are currently no known outstanding effects for the Commission Delegated Regulation (EU) 2016/1788. (See end of Document for details)

The brake identifier shall be an alphanumeric number consisting of the four characters 'ID2-' followed by a maximum of 20 characters.

A brake with the same identifier is a brake which does not differ with regard to the following criteria:

- (a) type of brake;
- (b) base material with respect to calliper housing, brake carrier, brake disc and brake drum;
- (c) dimensions with the suffix 'e' according to the test report;
- (d) the basic method used within the brake to generate the braking force;
- (e) in the case of disc brakes, the friction ring mounting method: fixed or floating;
- (f) brake factor B_F ;
- (g) different brake characteristics with respect to the requirements of Annex VII which are not covered by point 3.7.4.2.1 of this Appendix.

3.7.4.2.1. Differences allowed within the same brake identifier

The same brake identifier may include different brake characteristics with regard to the following criteria:

- (a) increase in maximum declared brake input torque C_{max} ;
- (b) deviation of declared brake disc and brake drum mass m_{dec} : ± 20 per cent;
- (c) method of attachment of the lining / pad on the brake shoe / back plate;
- (d) in the case of disc brakes, increase of maximum stroke capability of the brake;
- (e) effective length of the cam shaft;
- (f) declared threshold torque $C_{0,dec}$;
- (g) ± 5 mm from the declared external diameter of the disc;
- (h) type of cooling of the disc (ventilated/non-ventilated);
- (i) hub (with or without integrated hub);
- (j) disc with integrated drum – with or without parking brake function;
- (k) geometric relationship between disc friction surfaces and disc mounting;
- (l) brake lining type;

- (m) material variations (excluding changes in base material referred to in point 3.7.4.2.) for which the manufacturer confirms that such a material variation does not change the performance with respect to the required tests;
- (n) back plate and shoes.

3.7.4.3. Fe identifier

The Fe identifier indicates the test axle load. It shall be an alphanumeric number consisting of the four characters 'ID3-' followed by the Fe value in daN, without the daN unit identifier.

3.7.4.4. Test report identifier

The test report identifier shall be an alphanumeric number consisting of the four characters 'ID4-' followed by the base part of the test report number.

3.7.5. Automatic brake adjustment device (integrated and non-integrated)

3.7.5.1. Types of automatic brake adjustment device

The same type of automatic brake adjustment device does not differ with regard to the following criteria:

- (a) body: base material ;
- (b) maximal permitted brake shaft moment;
- (c) adjustment operating principle.

3.7.5.2. Versions of automatic brake adjustment device, with respect to the adjustment behaviour

Automatic brake adjustment devices within a type that have an impact on the running clearance of the brake are considered to be different versions.

- (iv) point 3.8 is replaced by the following:

3.8. Test criteria

In the case that a new test report, or a test report extension, is required for a modified axle or brake within the limits specified in the information document the following criteria are used to determine the necessity for further testing taking into account worst case configurations agreed with the Technical Service.

Abbreviations used in the subsequent table

CT (complete test)	Test:
	3.5.1. : Supplementary cold performance test
	3.5.2. : Fade test (Type-I test) ^a

^a If applicable

Changes to legislation: There are currently no known outstanding effects for the Commission Delegated Regulation (EU) 2016/1788. (See end of Document for details)

	3.5.3. : Fade test (Type-III test) ^a
FT (fade test)	Test: 3.5.1. Supplementary cold performance test 3.5.2. Fade test (Type-I test) ^a 3.5.3. Fade test (Type-III test) ^a

a If applicable

Differences according to point 3.7.4.2.1		Test criteria
(a)	Increase in maximum declared brake input torque C_{\max}	Change allowed without additional testing
(b)	Deviation of declared brake disc and brake drum mass $m_{\text{dec.}} \pm 20$ per cent	CT: The lightest variant shall be tested; if the nominal test mass for a new variant deviates less than 5 per cent from a previously tested variant with a higher nominal value then the test of the lighter version may be dispensed with. The actual test mass of the test specimen may vary ± 5 per cent from the nominal test mass.
(c)	Method of attachment of the lining / pad on the brake shoe / back plate	The worst case specified by the manufacturer and agreed by the Technical Services conducting the test
(d)	In the case of disc brakes, increase of maximum stroke capability of the brake	Change allowed without additional testing
(e)	Effective length of the cam shaft	The worst case is considered to be the lowest cam shaft torsional stiffness and shall be verified by either: (i) FT; or (ii) Change allowed without additional

a No test is required if the manufacturer can demonstrate that a change does not affect the stiffness.

Changes to legislation: There are currently no known outstanding effects for the Commission Delegated Regulation (EU) 2016/1788. (See end of Document for details)

		testing if by calculation the influence with respect to stroke and braking force can be shown. In this case the test report shall indicate the following extrapolated values: $s_e, C_e, T_e, T_e/F_e$.
(f)	Declared threshold torque $C_{0,dec}$	It shall be checked that the brake performance remains within the corridors of Diagram 1
(g)	± 5 mm from the declared external diameter of the disc	The worst case test is considered the smallest diameter The actual external diameter of the test specimen may vary ± 1 mm from the nominal external diameter specified by the axle manufacturer.
(h)	Type of cooling of the disc (ventilated/non-ventilated)	Each type shall be tested
(i)	Hub (with or without integrated hub)	Each type shall be tested
(j)	Disc with integrated drum – with or without parking brake function	Testing is not required for this feature
(k)	Geometric relationship between disc friction surfaces and disc mounting	Testing is not required for this feature
(l)	Brake lining type	Each type of brake lining
(m)	Material variations (excluding changes in base material referred to in point 3.7.4.2.) for which	Test not required for this condition
a	No test is required if the manufacturer can demonstrate that a change does not affect the stiffness.	

Changes to legislation: There are currently no known outstanding effects for the Commission Delegated Regulation (EU) 2016/1788. (See end of Document for details)

	the manufacturer confirms that such a material variation does not change the performance with respect to the required tests	
(n)	Back plate and shoes	Worst case test conditions ^a : Back plate : minimum thickness Shoe : lightest brake shoe
a	No test is required if the manufacturer can demonstrate that a change does not affect the stiffness.	

3.8.1. If an automatic brake adjustment device deviates from a tested one according to points 3.7.5.1 and 3.7.5.2, an additional test according to point 3.6.2 is necessary.

(7) Annex VIII is amended as follows:

- (a) point 2.2.18 is replaced by the following:
- 2.2.18. s': effective (useful) travel of control device in millimetres, determined as required by point 10.4.
- (b) point 2.2.23 is replaced by the following:
- 2.2.23. M*: braking torque as specified by the manufacturer. This braking torque shall produce at least the prescribed braking force B*;
- (c) point 2.2.24 is replaced by the following:
- 2.2.24. R: Dynamic tyre rolling radius. As an alternative for vehicles of categories Ra and Sa, the static loaded radius, as specified by the tyre manufacturer, may be used instead of the dynamic tyre rolling radius;
- (d) point 5.5 is replaced by the following:
- 5.5. In the case of inertia braking system on multi-axled drawbar towed vehicles, the loss of travel so referred to in in point 10.4.1 shall be measured.
- (e) section 9 is replaced by the following:
9. **Test reports**
- Applications for the approval of towed vehicles equipped with inertia braking systems shall be accompanied by the test reports relating to the control device and the brakes and the test report on the compatibility of the inertia type control device, the transmission device and the brakes of the towed vehicle, these reports including at least the particulars prescribed in Article 9 of Implementing Regulation (EU) 2015/504.
- (f) in point 10.3.1, the second paragraph is replaced by the following:

Changes to legislation: There are currently no known outstanding effects for the Commission Delegated Regulation (EU) 2016/1788. (See end of Document for details)

To check whether these conditions are complied with the following inequalities shall be applied:

- (g) point 10.3.1.1 is replaced by the following:

10.3.1.1. In mechanical-transmission inertia braking systems:

$$\left[\frac{B \times R}{\rho} + n P_0 \right] \frac{1}{(D^* - K) \times \eta_H} \leq i_H$$

»

- (h) point 10.3.1.2 is replaced by the following:

10.3.1.2. In hydraulic-transmission inertia braking systems:

$$\left[\frac{B \times R}{n \times \rho} + P_0 \right] \frac{1}{(D^* - K) \times \eta_H} \leq \frac{i_h}{F_{HZ}}$$

»

- (i) point 10.4.3.2 is replaced by the following:

10.4.3.2. in hydraulic-transmission inertia braking systems:

$$\frac{i_h}{F_{HZ}} \leq \frac{s'}{2 s_{B^*} \times n F_{HZ} \times V_f}$$

$$\text{and } \frac{s'}{i_H} \leq s_{Hz}$$

»

- (j) the following points 10.4.4, 10.4.4.1, 10.4.4.1.1, 10.4.4.1.2, 10.4.4.2, 10.4.4.2.1, 10.4.4.2.2, 10.4.5, 10.4.5.1, 10.4.5.2, 10.4.5.3 and 10.4.5.4 are inserted:

10.4.4. When the towed vehicle moves rearward the following inequalities shall be applied:

10.4.4.1. In mechanical-transmission inertia braking systems:

$$10.4.4.1.1. \frac{s'}{i_H} \leq s_r$$

$$10.4.4.1.2. 0,08 \times g \times G_A \times R \leq n \times M_r$$

10.4.4.2. In hydraulic-transmission inertia braking systems:

$$10.4.4.2.1. \frac{s'}{F_{Hz}} \leq V_r$$

$$10.4.4.2.2. 0,08 \times g \times G_A \times R \leq n \times M_r$$

10.4.5. Checks when an overload protector within the meaning of point 3.6. is fitted

The following inequalities shall be applied:

10.4.5.1. where the overload protector is mechanical on the inertia control device:

$$\frac{n \times P^*}{i_{Hz} \times \eta_{Hz} \times P^{\max}} \geq 1.2$$

Changes to legislation: There are currently no known outstanding effects for the Commission Delegated Regulation (EU) 2016/1788. (See end of Document for details)

10.4.5.2. where the overload protector is hydraulic on the inertia control device:

$$\frac{p^*}{p_{\max}^*} \geq 1.2$$

10.4.5.3. if the overload protector is on the inertia control device:

$$\frac{D_{op}}{D^*} \geq 1.2$$

10.4.5.4. if the overload protector is fitted on the brake:

$$\frac{M_{op}}{B \times R} \geq 1.2^{acc}$$

- (k) in Appendix 1, Figure 5A is replaced by the following:
 ‘Figure 5A Mechanical-transmission braking system (See point 2.3 of this Annex)

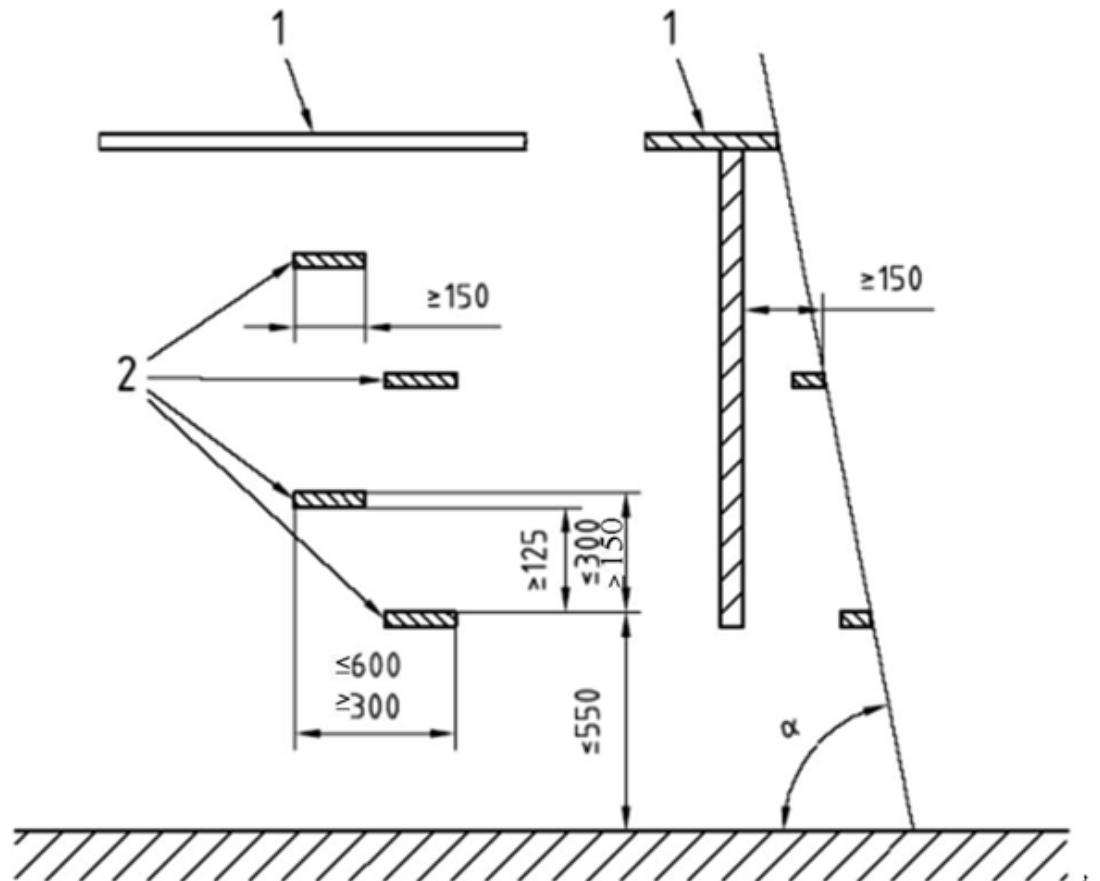

- (8) Annex IX is amended as follows:

- (a) point 5.2.2.2 is deleted;
- (b) the following point 5.2.3.1 is inserted:
- 5.2.3.1. If, in the case of a hydrostatic drive, the vehicle cannot be stopped on a gradient, then it is permissible to operate the parking braking system to stop the vehicle from residual creep speed to standstill.

For this purpose the parking braking system has to be designed such that it is possible for it to be actuated during driving.;

- (c) point 5.3.4 is replaced by the following:
- 5.3.4. The braking force distribution of the service brake system shall be designed in such a way that during braking there is no significant moment around the vertical axis of the vehicle if the limit of adhesion between tyres and road on homogeneous road surfaces is not attained.
- (d) in point 5.3.12, the second sentence is replaced by the following:
- This shall be demonstrated by compliance with the technical requirements laid down in accordance with the relevant provisions of Article 19 of Delegated Regulation (EU) 2015/208.
- (e) in point 6.1.2.2, the first paragraph is replaced by the following:
- Lift-off of an axle is permissible for vehicles of Class I and Class II at a deceleration exceeding $4,5 \text{ m/s}^2$. However, the driving stability shall be preserved.
- (f) in point 6.2.2, the second sentence is replaced by the following:
- In the case of Class III vehicles this sequence shall be automatic, using only the service brake control device.
- (g) in the Table of point 6.4.4.2, the fifth row is replaced by the following:
- | | | |
|-------------------------|----|----|
| Friction braking system | 80 | 60 |
|-------------------------|----|----|
- (h) in the second paragraph of point 6.5.2, the second sentence is replaced by the following:
- In the case of Class III vehicles this sequence shall be automatic, using only the parking brake control device.
- (9) Annex XI is amended as follows:
- (a) in point 4.4, the second sentence is replaced by the following:
- That requirement shall be demonstrated by compliance with the technical requirements laid down in Article 19 of Delegated Regulation (EU) 2015/208.
- (b) in Appendix 3, point 1.1 is replaced by the following:
- 1.1. The prescribed braking rate referred to in point 5.3.5 of this Annex may be calculated by reference to the measured coefficient of adhesion of the two surfaces on which this test is carried out.
- The two surfaces shall satisfy the conditions set out in point 5.3.4. of this Annex.

- (10) Annex XII is amended as follows:

Changes to legislation: There are currently no known outstanding effects for the Commission Delegated Regulation (EU) 2016/1788. (See end of Document for details)

- (a) in point 3.1, the first sentence is replaced by the following:
- The electric control line of the tractor shall provide information as to whether the requirements of point 2.2.1.16.3 of Annex I can be satisfied by the electric control line, without assistance from the pneumatic control line.
- (b) point 3.3.3 is replaced by the following:
- 3.3.3. when the electric control signal has exceeded the equivalent of 100 kPa for more than 1 second, the towed vehicle shall verify that a pneumatic signal is present; should no pneumatic signal be present, the driver shall be warned from the towed vehicle by the separate yellow warning signal specified in point 2.2.1.29.2 of Annex I.
- (c) in point 3.4, the first sentence is replaced by the following:
- A towed vehicle may be equipped as described in point 2.1.4.1.3 of Annex I, provided that it can only be operated in conjunction with a tractor with an electric control line which satisfies the requirements of point 2.2.1.16.3 of Annex I.
- (d) in point 3.5.3, the first sentence is replaced by the following:
- When the tractor is equipped according to point 2.1.4.1.3 of Annex I or, if it satisfies the requirements of point 2.2.1.16.3 of Annex I without assistance from the pneumatic control line, point 2.1.4.1.2 of Annex I, the actuation of the parking braking system on the tractor shall actuate a braking system on the towed vehicle via the electric control line.
- (e) in the first paragraph of point 4.1.3, the second sentence is replaced by the following:
- When the prescribed service braking performance can no longer be achieved (red warning signal), failures resulting from a loss of electrical continuity (e.g. breakage, disconnection) shall be signalled to the driver as soon as they occur, and the prescribed residual braking performance shall be fulfilled by operating the service braking control device in accordance with point 3.1.4 of Annex II.
- (f) in point 4.1.10, the first sentence is replaced by the following:
- In the case of a failure in the electric control transmission of a towed vehicle, electrically connected via an electric control line only, according to point 2.1.4.1.3 of Annex I, braking of the towed vehicle shall be ensured according to point 2.2.1.17.2.1 of Annex I.
- (g) in point 4.2.2, the third paragraph is replaced by the following:
- For towed vehicles, electrically connected via an electric control line only, according to point 2.1.4.1.3 of Annex I, and fulfilling the requirements set out in point 2.2.1.17.2.2 of Annex I with the performance prescribed in point 3.2.3 of Annex II, it is sufficient that the provisions of point 4.1.10 of this Annex are invoked, when a braking performance of at least 30 % of the prescribed performance for the service braking system of the towed vehicle can no longer be ensured, by either providing the ‘supply line

Changes to legislation: There are currently no known outstanding effects for the Commission Delegated Regulation (EU) 2016/1788. (See end of Document for details)

braking request' signal via the data communication part of the electric control line or by the continuous absence of this data communication.

- (h) in point 3.2.2.2.1.4 of Appendix 2, the second sentence is replaced by the following:

After the braking system has checked that no defects that require identification by the red warning signal are present the message referred to in this point shall be set to 00_b.

- (11) Annex XIII is amended as follows:

- (a) point 1.2 is deleted;
- (b) the title and first paragraph of section 3 are replaced by the following:

3. Alternative requirements

As an alternative to the requirements of sections 1 and 2, hydraulic connection of the single line type installed on tractors shall fulfil all the requirements of this section, in addition to the provisions of point 2.1.

- (c) point 3.9 is replaced by the following:

3.9. Braking valve and energy source shall be marked in accordance with the requirements laid down in Article 24 of Delegated Regulation (EU) 2015/208..

ANNEX V

Annexes I, III, V, VII, X, XII to XV, XVII, XIX, XX, XXII, XXV to XXXI, XXXIII and XXXIV to Delegated Regulation (EU) 2015/208 are amended as follows:

- (1) Annex I is amended as follows:

- (a) above the row with Regulation Number 3, the following row is inserted:

1	Lighting installation	Incorporating all valid text up to 02 series of amendments	OJ L 177, 10.7.2010, p. 1	T and C;
---	-----------------------	--	---------------------------	----------

- (b) above the row with Regulation Number 7, the following row is inserted:

6	Lighting, light signalling devices and their light sources	Supplement 18 to the 01 series of amendments Corrigendum 1 to Supplement 18	OJ L 177, 10.7.2010, p. 40	T, C, R and S;
---	--	---	----------------------------	----------------

Changes to legislation: There are currently no known outstanding effects for the
Commission Delegated Regulation (EU) 2016/1788. (See end of Document for details)

		Supplement 19 to the 01 series of amendments		
--	--	---	--	--

(c) above the row with Regulation Number 10, the following row is inserted:

8	Lighting installation	Incorporating all valid text up to 05 series of amendments Corrigendum 1 to Revision 4 of the Regulation	OJ L 177, 10.7.2010, p. 71	T and C;
---	--------------------------	--	--	----------

(d) above the row with Regulation Number 21, the following row is inserted:

20	Lighting installation	Incorporating all valid text up to 03 series of amendments	OJ L 177, 10.7.2010, p. 170	T and C;
----	--------------------------	--	---	----------

(e) above the row with Regulation Number 25, the following row is inserted:

23	Lighting, light signalling devices and their light sources	Supplement 17 to the original version of the Regulation	OJ L 4, 7.1.2012, p. 18	T, C, R and S
----	---	--	---	---------------

(f) above the row with Regulation Number 79, the following row is inserted:

77	Lighting installation	Supplement 14 to the original version of the Regulation	OJ L 4, 7.1.2012, p. 21	T, C, R and S;
----	--------------------------	--	---	-------------------

(2) in Annex III, point 2.6 is replaced by the following:

2.6. In order for approval authorities may calculate their maximum theoretical speed, the manufacturer shall specify as a guide the gear ratio, the actual forward movement of the powered wheels corresponding to one complete revolution, and the rpm at maximum power output or the cut-off initiation speed under full load with the throttle fully open, whichever is higher, and the speed governor, if fitted, adjusted as laid down by the manufacturer.

Changes to legislation: There are currently no known outstanding effects for the Commission Delegated Regulation (EU) 2016/1788. (See end of Document for details)

The maximum theoretical speed shall be calculated without the tolerances referred to in point 2.5.

(3) Annex V is amended as follows:

(a) section 1 is replaced by the following:

1. **Definitions**

For the purposes of this Annex, the definitions in section 1 of Annex XXXIII shall apply. The following definitions shall also apply:

(b) point 2.3 is amended as follows:

(i) the first sentence is replaced by the following:

The requirements set out in point 2.2 are not applicable to C-category tractors with steel track chains equipped with differential steering.

(ii) the third sentence is replaced by the following:

If the steering system is combined with the braking system, the requirements laid down in Commission Delegated Regulation (EU) 2015/68⁽¹⁵⁾ shall apply.

(c) in point 3.4.1.1 the fourth sentence is replaced by the following:

Without prejudice to the requirements laid down in Delegated Regulation (EU) 2015/68, if there is a hydraulic connection between the hydraulic steering equipment and the hydraulic braking equipment, and if both are supplied from the same energy source, the force required to activate the steering equipment shall not exceed 40 daN if either of the systems should fail.

(4) in Annex VII, point 2 is replaced by the following:

2. The part concerning the vision beside the tractor, in ISO 5721-2:2014 on the field of vision to the side and to the rear of agricultural tractors. The requirements of point 5.1.3 of ISO 5721-2:2014 may be fulfilled by a combination of direct and indirect view.

(5) Annex X is replaced by the following:

ANNEX X

Requirements on driver information systems

1. **Definitions**

“Virtual terminals” means electronic on-board information systems with display screens that provide an operator with visual information on the performance of the vehicle and its systems, and that allow the operator to monitor and control various functions via a touch screen or keypad.

2. **Requirements**

*Changes to legislation: There are currently no known outstanding effects for the
Commission Delegated Regulation (EU) 2016/1788. (See end of Document for details)*

- 2.1 Driver information systems shall be designed so as to minimize distraction of the driver whilst conveying the necessary information
- 2.2 Information provided in a non-language format on a digital screen shall meet the requirements of ISO 3767: part 1 (1998 +A2:2012) and part 2 (2008).
- (6) Annex XII is amended as follows:
- (a) section 3 is replaced by the following:
3. **Approval**
- The templates of the documents referred to in points 2.1 to 2.4, to be submitted during the EU type-approval process, shall be those set out in Annex I of Implementing Regulation (EU) 2015/504.
- (b) section 4 is replaced by the following:
4. **Approval number and markings**
- Each vehicle approved in accordance with the requirements set out in this Annex shall be assigned an approval number and marking, in accordance with the model set out in Annex IV of Implementing Regulation (EU) 2015/504.
- (c) points 6.1 and 6.1.1 are replaced by the following:
- 6.1. Main-beam headlamps (UNECE Regulations Nos 1, 8, 20, 98, 112 and 113, as referenced in Annex I to this Regulation)
- 6.1.1. Presence: Mandatory for tractors with maximum design speed exceeding 40 km/h. Optional for other tractors. Main-beam headlamps are prohibited on R- and S-category vehicles. Main-beam head lamps, as prescribed in UNECE Regulation No 1, as referenced in Annex I, are only allowed on tractors with maximum design speed not exceeding 40 km/h. Main-beam head lamps, as prescribed in UNECE Regulations Nos 1, 8 and 20, as referenced in Annex I, are only allowed on new tractor types until 31 December 2020 and are only allowed on new tractors until 31 December 2022.
- (d) point 6.2 is replaced by the following:
- 6.2. Dipped-beam headlamps (UNECE Regulations Nos 1, 8, 20, 98, 112 and 113, as referenced in Annex I to this Regulation);
- (e) point 6.2.1 is replaced by the following:
- 6.2.1. Presence: Tractors shall be equipped with dipped-beam headlamps. Dipped-beam headlamps are prohibited on R- and S-category vehicles. Dipped-beam head lamps, as prescribed in UNECE Regulation No 1, as referenced in Annex I, are only allowed on tractors with maximum design speed not exceeding 40 km/h. Dipped-beam head lamps, as prescribed in UNECE Regulations Nos 1, 8 and 20, as referenced in Annex I, are only allowed on new tractor types until 31 December 2020 and are only allowed on new tractors until 31 December 2022.

Changes to legislation: There are currently no known outstanding effects for the Commission Delegated Regulation (EU) 2016/1788. (See end of Document for details)

- (f) point 6.25.5.1.2 is replaced by the following:
- 6.25.5.1.2 The other two retro-reflectors shall keep within a maximum height of 2 500 mm above the ground and shall comply with point 6.25.5.1.
- (7) Annex XIII is amended as follows:
- (a) in section 1, the second paragraph is replaced by the following:
- Definitions for the protection of drive components, in accordance with the requirements laid down in Article 20 of Commission Delegated Regulation (EU) No 1322/2014⁽¹⁶⁾, are valid for this Annex.
- (b) in Part 2, point 1.1 is replaced by the following:
- 1.1. Interior parts of the passenger compartment excluding the side doors, with all doors, windows and access lids in the closed position;
- (c) in point 1.1.3.2 of Part 2, the following sentence is added:
- This requirement shall not apply to parts of control devices and of casings between their switches, which protrude less than 5 mm, but the outward facing angles of such parts shall be blunted, save where such parts protrude less than 1,5 mm.
- (d) in point 3.1 of Part 2, the second paragraph is replaced by the following:
- If the panels and components, etc., are covered with materials softer than 60 Shore A hardness, the procedure for the measuring of projections described in the first paragraph shall apply only after the removal of such materials.
- (e) in section 4 of Part 2, the heading is replaced by the following:
- Apparatus and procedure for application of points 1.1.3 and 1.1.4;
- (f) Part 4 is replaced by the following:

PART 4

Seat belts

The requirements laid down in Article 21 of Delegated Regulation (EU) No 1322/2014 shall apply.

- (8) Annex XIV is replaced by the following:

ANNEX XIV

Requirements on vehicle exterior and accessories

1. Definitions

*Changes to legislation: There are currently no known outstanding effects for the
Commission Delegated Regulation (EU) 2016/1788. (See end of Document for details)*

For the purposes of this Annex, the definitions in section 1 of Annex XII and in section 1 of Annex XXXIII shall apply. The following definitions shall also apply:

- 1.1. “External surface” means the outside of the vehicle including wheels, tracks, doors, bumpers, bonnet, access means, tanks, mudguards, exhaust system.
- 1.2. “Radius of curvature” means the radius of the arc of a circle which comes closest to the rounded form of the component under consideration.
- 1.3. “Extreme outer edge“ of the vehicle means, in relation to the sides of the vehicle, the plane parallel to the median longitudinal plane of the vehicle coinciding with its outer lateral edge, account not being taken of the projection:
 - (a) of tyres near their point of contact with the ground, and connections for tyre pressure gauges and tyre inflating/deflating devices/ducts;
 - (b) of any anti-skid devices which may be mounted on the wheels;
 - (c) of rear-view mirrors, including their support;
 - (d) of side direction indicator lamps, end outline marker lamps, front and rear position (side) lamps, parking lamps, retro-reflectors, signalling panels and SMV rear marking plates;
 - (e) of articulation structures on foldable ROPS of T2, C2, T3 and C3 category tractors;
 - (f) of mechanical, electrical, pneumatic or hydraulic connections, and their supports on the sides of tractors.

2. Scope

- 2.1. This Annex shall apply to those parts of the external surface which, with the vehicle in the laden condition, equipped with tyres of the highest diameter or set of tracks of the highest vertical dimension, for which it is approved, with all doors, windows and access lids etc., in the closed position, are:
 - 2.1.1. at a height of less than 0,75 m, the parts forming only at the sides of the vehicle the extreme outer edge in each vertical plane perpendicular to the length axis of the vehicle, with the exemption of those parts with distance greater than 80 mm from the side extreme outer edge of the vehicle and towards its median longitudinal plane, when the vehicle is equipped with the tyres or set of tracks, described in point 2.1, giving the least track width; if more than one tyre or set of tracks, described in point 2.1, exist, the one giving the minimum vehicle width shall be considered;
 - 2.1.2. at the sides and at a height between 0,75 and 2 m, all parts, except:
 - 2.1.2.1. the parts that cannot be contacted by a sphere with a diameter of 100 mm, when approaching horizontally in each vertical plane perpendicular to the length axis of the vehicle; the displacement of the sphere shall not exceed 80 mm, starting from the extreme outer edge of each of the left and right side of the vehicle and towards its median longitudinal plane, when the vehicle is equipped with the tyres or set of tracks, described in point 2.1, giving the least track width; if more than one tyre or set of tracks, described in

point 2.1, exist, the one giving the minimum vehicle width shall be considered;

- 2.2. The purpose of these provisions is to reduce the risk or seriousness of bodily injury to a person hit by the exterior of the vehicle or brushing against it in the event of a collision. This is valid both when the vehicle is stationary and in motion.
- 2.3. This annex does not apply to exterior rear-view mirrors, including their support.
- 2.4. This Annex does not apply neither to the track chains nor to the parts of the tracks that are inside of the vertical plane formed by the extreme outer edge of the track belt or track chain of vehicles of category C.
- 2.5. This Annex does not apply to the parts of the wheels and of the wheel guards that are inside of the vertical plane formed by the exterior lateral wall of the tyres.
- 2.6. This Annex does not apply to steps and rungs, including their support, mentioned in points 3.3. and 4.2. of Annex XV to Delegated Regulation (EU) No 1322/2014.
- 2.7. This annex does not apply to mechanical, electrical, pneumatic or hydraulic connections, including their supports, mounted on the sides of tractors.
- 2.8. This annex does not apply to articulation structures on foldable ROPS of T2, C2, T3 and C3 category tractors.

3. **Requirements**

- 3.1. The external surface of the vehicle shall not exhibit, directed outwards, any pointed or sharp parts, rough surfaces, or any projections of such shape, dimensions, direction or hardness as to be likely to increase the risk or seriousness of bodily injury to a person hit by the external surface or brushing against it in the event of a collision.
- 3.2. The external surfaces on each side of the vehicle shall not exhibit, directed outwards, any parts likely to catch on pedestrians, cyclists or motor cyclists.
- 3.3. No protruding part of the external surface shall have a radius of curvature less than 2,5 mm or each external part with edges shall be positioned with respect to the longitudinal axis so that the outside face of such part shall be flat and without edges and on a plane parallel with the vertical plane containing the longitudinal axis. This requirement shall not apply to parts of the external surface which protrude less than 5 mm, but the outward facing angles of such parts shall be blunted, save where such parts protrude less than 1,5 mm.
- 3.4. Protruding parts of the external surface, made of a material of hardness not exceeding 60 shore A, may have a radius of curvature less than 2,5 mm. The hardness measurement by the Shore A procedure may be replaced by a hardness value declaration from the manufacturer of the component.
- 3.5. Vehicles equipped with hydro-pneumatic, hydraulic or pneumatic suspension or a device for automatic levelling according to load shall be tested with the vehicle in the laden condition.

*Changes to legislation: There are currently no known outstanding effects for the
Commission Delegated Regulation (EU) 2016/1788. (See end of Document for details)*

- 3.6. For connecting structures on ROPS of T2, C2, T3 and C3 category tractors only point 3.1 shall apply.
- 3.7. For side direction indicator lamps, end outline marker lamps, front and rear position (side) lamps, parking lamps, retro-reflectors, signalling panels, working lamps, SMV rear marking plates, including their supports, only points 3.1 and 3.2 shall apply.
- 3.8. Exposed implements on vehicles of categories R and S that have sharp edges or teeth when set in road transport mode and that are already covered by Directive 2006/42/EC are exempted from complying with points 3.1 to 3.5. For exposed areas of any other part of vehicles of categories R and S with maximum design speed exceeding 60 km/h, points 3.1 to 3.5 shall apply. For exposed areas of any other part of vehicles of categories R and S with maximum design speed not exceeding 60 km/h, only points 3.1 and 3.2 shall apply.
- (9) in Annex XV, Part 2 is amended as follows:
- (a) points 1.1.1 and 1.1.2 are replaced by the following:
- 1.1.1. The application for approval of a vehicle type, with regard to its electromagnetic compatibility pursuant to Articles 24 and 26 of Regulation (EU) No 167/2013 and Annex I to Implementing Regulation (EU) 2015/504 shall be submitted by the vehicle manufacturer.
- 1.1.2. The vehicle manufacturer shall submit the information document, the model of which is set out in Annex I to Implementing Regulation (EU) 2015/504.
- (b) in point 1.1.4, the second sentence is replaced by the following:
- This vehicle shall represent the vehicle type specified in the information document set out in Article 2 of Implementing Regulation (EU) 2015/504.
- (c) in point 1.2.1, the first sentence is replaced by the following:
- The application for approval of a type of ESA with regard to its electromagnetic compatibility pursuant to Articles 24 and 26 of Regulation (EU) No 167/2013 and Article 2 of Implementing Regulation (EU) 2015/504 shall be submitted by the vehicle manufacturer or by the manufacturer of the ESA.
- (d) point 1.2.2 is replaced by the following:
- 1.2.2. The vehicle manufacturer shall submit the information document, the model of which is set out in Annex I to Implementing Regulation (EU) 2015/504.
- (e) point 1.2.6 is replaced by the following:
- 1.2.6. Where applicable, any restrictions on use shall be identified. Any such restrictions shall be included in the information document referred to in Article 2 of Implementing Regulation (EU) 2015/504 or in the EU type-approval certificate referred to in Annex V of Implementing Regulation (EU) 2015/504.

- (f) point 2.1 is replaced by the following:
- 2.1. Every ESA conforming to a type approved pursuant to this Regulation shall bear an EU type-approval mark in accordance with Article 5 of Implementing Regulation (EU) 2015/504 and Annex XX to this Regulation.
- (g) point 3.3.2.4 is replaced by the following:
- 3.3.2.4. Notwithstanding the limits defined in points 3.3.2.1, 3.3.2.2 and 3.3.2.3, if, during the initial step described in point 1.3 of Part 4, the signal strength measured at the vehicle broadcast radio antenna is less than 20 dB microvolts/m (10 microvolts/m) over the frequency range 88 to 108 MHz, then the vehicle shall be deemed to comply with the limits for narrowband emissions and no further testing shall be required.
- (10) in Annex XVII, points 1.1 and 1.2 are replaced by the following:
- 1.1. Tractors with cab shall be fitted with a heating system which complies with this Annex. Tractors with cab may be fitted with air conditioning systems. Where fitted, such systems shall comply with this Annex.
- 1.2. The heating system, in combination with the cab ventilation, shall be able to defrost and demist the windscreen. Heating and cooling systems shall be tested in accordance with sections 8 and 9, paragraphs 8.1.1 to 8.1.4 and 9.1.1 to 9.1.4 of ISO 14269-2:2001, respectively. During the test, system controls shall be set according to the manufacturer's specifications. The test reports shall be included into the information document.
- (11) Annex XIX is amended as follows:
- (a) point 2.6.1 is replaced by the following:
- 2.6.1. If the height of the upper edge of the plate from the ground surface does not exceed 1,20 m, the plate shall be visible in the whole space included within the following four planes:
- (a) the two vertical planes touching the two lateral edges of the plate and forming an angle measured outwards to the left and to the right of the plate of 30° to the longitudinal median plane of the vehicle;
- (b) the plane touching the upper edge of the plate and forming an angle measured upwards of 15° to the horizontal;
- (c) the horizontal plane through the lower edge of the plate.
- (b) the following point 2.6.1.a is inserted:
- 2.6.1.a. If the height of the upper edge of the plate from the ground surface exceeds 1,20 m, the plate shall be visible in the whole space included within the following four planes:

Changes to legislation: There are currently no known outstanding effects for the Commission Delegated Regulation (EU) 2016/1788. (See end of Document for details)

- (a) the two vertical planes touching the two lateral edges of the plate and forming an angle measured outwards to the left and to the right of the plate of 30° to the longitudinal median plane of the vehicle;
 - (b) the plane touching the upper edge of the plate and forming an angle measured upwards of 15° to the horizontal;
 - (c) the plane touching the lower edge of the plate and forming an angle measured downwards of 15° to the horizontal.
- (c) point 2.6.2 is replaced by the following:
- 2.6.2. No structural element, even when fully transparent, shall be located in the space described in points 2.6.1 and 2.6.1a.
- (12) Annex XX is amended as follows:
- (a) points 2.1 and 2.2 are replaced by the following:
 - 2.1. All agricultural or forestry vehicles shall be provided with the plate and inscriptions described in the following points. The plate and inscriptions shall be attached by the manufacturer.
 - 2.2. All components or separate technical units conforming to a type approved pursuant to Regulation (EU) No 167/2013 shall bear an EU type-approval mark described in point 6 of this Annex or a mark provided in Article 34(2) of that Regulation and set out in Article 5 of Implementing Regulation (EU) 2015/504.
 - (b) points 3.1 and 3.2 are replaced by the following:
 - 3.1. A statutory plate, modelled as set out in Annex IV to Implementing Regulation (EU) 2015/504, shall be firmly attached in a conspicuous and readily accessible position on a part normally not subject to replacement during normal use, regular maintenance or repair (e.g. due to accident damage). It shall show clearly and indelibly the information specified in the model for the EU type-approval mark set out in Annex IV to Implementing Regulation (EU) 2015/504.
 - 3.2. The manufacturer may give additional information below or to the side of the prescribed inscriptions, outside a clearly marked rectangle enclosing only the information required by Annex IV of Implementing Regulation (EU) 2015/504.
 - (c) point 4.3 is replaced by the following:
 - 4.3. It shall be marked on the chassis or other similar structure, where possible on the front right-hand side of the vehicle.
 - (d) section 5 is replaced by the following:

5. Characters

The characters specified in the model for the EU type-approval mark set out Annex IV to Implementing Regulation (EU) 2015/504 shall be used for the markings referred to in sections 3 and 4.

- (e) in section 6, the first sentence is replaced by the following:
- Every separate technical unit or component, conforming to a type in respect of which EU separate technical unit or component type-approval has been granted in accordance with Chapter V of Regulation (EU) No 167/2013, shall bear an EU separate technical unit or component type-approval mark, pursuant to Article 34(2) of that Regulation and in accordance with Article 5 of Implementing Regulation (EU) 2015/504.
- (13) Annex XXII is amended as follows:
- (a) in point 1, the second paragraph is replaced by the following:
- For the purposes of this Annex, definitions of ‘drawbar towed vehicle’ and ‘rigid drawbar towed vehicle’, set out in Article 2 of Delegated Regulation (EU) 2015/68, shall apply.
- The following definitions shall also apply:
- (b) point 1.2 is replaced by the following:
- 1.2. ‘Technically permissible maximum mass per axle’ means the mass corresponding to the maximum permissible static vertical load transmitted to the ground by the wheels of the axle or track undercarriages, on the basis of the construction features of the axle and of the vehicle and their design performances irrespective from the load capacity of the tyres or tracks.
- (c) point 2.3.2 is replaced by the following:
- 2.3.2. For vehicles of categories R and S imposing a significant static vertical load on the tractor (rigid drawbar towed vehicle and centre-axle towed vehicle), the maximum permissible mass of the vehicle shall be considered to be the sum of the maximum permissible masses per axle and shall be applicable for type-approval purposes, instead of the corresponding maximum permissible mass mentioned in the third column of Table 1. The significant static vertical load on the tractor shall be taken into account in the type-approval of the tractor as laid down in point 2.3.1.
- (14) in section 3 of Annex XXV, the second paragraph is replaced by the following:
- If necessary, measure(s) for charge dissipation shall be provided. However, no charge dissipation system is required for fuel tanks designed for containing a fuel with a flash point of at least 55 °C. The flash point shall be determined in accordance with ISO 2719:2002.
- (15) in Annex XXVI, section 1 is replaced by the following:
1. **General**
- Vehicles of category R covered by this Regulation shall be designed so as to provide effective protection against underrunning from the rear by vehicles of categories M₁ and N₁⁽¹⁷⁾. They shall comply with the requirements set out in sections 2 and 3 of this Annex, shall be granted a type-approval certificate set out in Annex V to Implementing Regulation (EU) 2015/504 and the EU type-approval mark, set out in point 5.2 of Annex IV to that Regulation, shall be affixed to the rear protective structure.

*Changes to legislation: There are currently no known outstanding effects for the
Commission Delegated Regulation (EU) 2016/1788. (See end of Document for details)*

- (16) in Annex XXVII, points 2.4.1.1 and 2.4.1.2 are replaced by the following:
- 2.4.1.1. on a drawbar trailer: not more than 500 mm to the rear of the transverse vertical plane tangential to the rearmost part of the tyre on the wheel immediately forward of the guard;
 - 2.4.1.2. on a rigid drawbar trailer or centre-axle trailer: in the area forward of the transverse plane passing through the centre of the front axle but not more than the front of the bodywork, if any, to ensure the normal manoeuvrability of the trailer.
- (17) in Annex XXVIII, section 7 is replaced by the following:
7. **Length of the platform for tractors of categories T4.3 and T2**
- 7.1. For tractors of category T4.3, the length of the platform shall not exceed 2,5 times the maximum front or rear track of the tractor, whichever is the larger.
 - 7.2. For tractors of category T2, the length of the platform shall not exceed 1,8 times the maximum front or rear track of the tractor, whichever is the larger.
- (18) Annex XXIX is amended as follows:
- (a) in section 3, the first paragraph is replaced by the following:

The towing device shall be of the slotted-jaw type or a winch suitable for its application. The opening at the centre of the locking pin shall be 60 mm + 0,5/- 1,5 mm and the depth of the jaw measured from the centre of the pin shall be 62 mm - 0,5 / +5 mm.
 - (b) section 5 is replaced by the following:

5. **Instructions**

The correct use of the towing device shall be explained in the Operator's manual, in accordance with the requirements laid down in Article 25 of Delegated Regulation (EU) No 1322/2014.
- (19) Annex XXX is amended as follows:
- (a) point 2.2.4.3 is replaced by the following:

2.2.4.3. The relevant information concerning load and speed indices as well as the applicable tyre inflation pressures shall be stated clearly in the instruction manual of the vehicle in order to ensure that suitable replacement tyres with an appropriate load capacity shall be fitted when necessary, once the vehicle has been put into service.
 - (b) point 2.2.6.2 is replaced by the following:

2.2.6.2. In case of "Improved Flexion Tyre" or "Very High Flexion Tyre" classified in category of use "Tractor – Drive wheel" (marked with prefix IF or VF) operated at speeds up to a maximum speed of 10 km/h fitted to a vehicle equipped with a "Front end loader", the maximum load on a tyre shall not exceed 1,40 times the load corresponding to the load index marked on the tyre and the relevant reference pressure shall be increased by 80 kPa.
 - (c) point 2.2.6.3 is replaced by the following:

2.2.6.3. Where tyres classified in category of use “Tractor – Drive wheel” are marked with speed symbols D or A8 and fitted to agricultural trailers operating at speeds between 25 km/h and 40 km/h, the maximum load on a tyre shall not exceed 1,20 times the load corresponding to the load index marked on the tyre.

- (20) in Annex XXXI, point 1.1 is replaced by the following:
- 1.1. Tb and Rb category vehicles shall be equipped with wheel guards (parts of the bodywork, mudguards, etc.).
- (21) Annex XXXIII is amended as follows:
- (a) points 1.1, 1.2 and 1.3 are replaced by the following:
- 1.1. “Track undercarriage” means a system comprising at least two of the following items: track rollers, track idler and track driver, with a continuous track chain or track belt running around them.
- 1.2. “Track rollers” means the cylinders in the track undercarriage that transmit the mass of the vehicle and track undercarriage to the ground via the track belt or track chain.
- 1.3. “Track belt” means a continuous flexible rubber like belt, reinforced internally to enable the tractive forces.
- (b) the following points 1.6, 1.7, 1.8 and 1.9 are inserted:
- 1.6. “Track idler” means sprockets or pulleys in the track undercarriage that do not transmit torque to the track belt or track chain, their main function being the tensioning of the track chain or track belt; track idlers may also create the ramp up/down angles in the track geometry.
- 1.7. “Track driver” means the sprocket or cage wheel in the track undercarriage that transmit torque from the vehicle drive system to the track belt or track chain.
- 1.8. “Track chain” means a continuous metallic chain which engages with the track driver and where each link is with a transversal metallic track shoe, the latter optionally padded with a rubber strip for road surface protection.
- 1.9. Figures illustrating definitions set out in points 1.2, 1.6 and 1.7:
;
- (c) points 2.1.1, 2.1.2 and 2.1.3 are replaced by the following:
- 2.1.1. Vehicles with maximum design speed not exceeding 15 km/h shall be equipped either with track chains or with track belts.
- 2.1.2. Vehicles with a maximum design speed exceeding 15 km/h and not exceeding 40 km/h shall be equipped with track belts only.
- 2.1.3. Vehicles with a maximum design speed exceeding 40 km/h shall be equipped with track belts only.

*Changes to legislation: There are currently no known outstanding effects for the
Commission Delegated Regulation (EU) 2016/1788. (See end of Document for details)*

- (d) points 3.1 and 3.2 are replaced by the following:
 - 3.1. Vehicles with a maximum design speed of not less than 15 km/h shall be equipped with track belts.
 - 3.2. Track undercarriages shall be non-damaging to roads. Vehicles with track undercarriages are non-damaging to roads if the limits set out in points 3.3 to 3.5 are not exceeded and the contact surface of the track undercarriage with the road pavement is composed of an elastomeric material (such as rubber, etc.).
- (e) point 3.3.1 is replaced by the following:
 - 3.3.1. Track chains;
- (f) point 3.3.1.2 is replaced by the following:
 - 3.3.1.2. For vehicles with a combination of wheeled axles and tracks, the load acting through the wheeled axles with the vehicle in the laden condition shall be measured using suitable weigh pads and subtracted from the overall maximum permissible mass to calculate P. Alternatively, the manufacturer's declared maximum combined load for the track undercarriages may be substituted for the maximum permissible vehicle mass.
- (g) point 3.3.2 is replaced by the following:
 - 3.3.2. Track belts;
- (h) point 3.3.2.2 is replaced by the following:
 - 3.3.2.2. For vehicles with a combination of wheeled axles and tracks, the load acting through the wheeled axles with the vehicle in the laden condition shall be measured using suitable weigh pads and subtracted from the overall maximum permissible mass to calculate P. Alternatively, the manufacturer's declared maximum combined load for the track undercarriages may be substituted for the maximum permissible vehicle mass.
- (i) points 3.9.1.1 and 3.9.1.2 are replaced by the following:
 - 3.9.1.1. For vehicles with only one track undercarriage at each side, the steering function shall be performed by changing the speed between the left-hand side and right-hand side track undercarriages.
 - 3.9.1.2. For vehicles with two track undercarriages at each side, the steering function shall be performed by articulation of the front and rear part of the vehicle around a central vertical axis or by pivoting of two opposite or all four track undercarriages.
- (j) point 3.9.2.1 is replaced by the following:
 - 3.9.2.1. The steering function shall be performed by articulation of the front and rear part of the vehicle around a central vertical axis or by articulation of all track undercarriages.

- (22) Annex XXXIV is amended as follows:
- (a) point 1.3 is replaced by the following:
 - 1.3. “Reference centre of mechanical coupling on tractor” means the point on the pin axis which is equidistant from the wings in the case of a fork and the point resulting from the intersection of the plane of symmetry of the hook with the generatrix of the concave part of the hook at the level of contact with the ring when this is in the traction position.
 - (b) the following point 1.3.a is inserted:
 - 1.3.a. “Reference centre of mechanical coupling on towed vehicle” means, for coupling devices with a cylindrical or rounded head, the point of intersection between the vertical axis passing through the centre of the device hole and the centreline plane of the cylindrical or rounded device head, and, for coupling devices with spherical head, the point of the geometric centre of the spherical cavity.
 - (c) point 1.4 is replaced by the following:
 - 1.4. “Height above ground of mechanical coupling on tractor” means the distance between the horizontal plane through the reference centre of the mechanical coupling on tractor and the horizontal plane on which the wheels of the tractor are resting.
 - (d) point 2.2 is replaced by the following:
 - 2.2. The mechanical coupling components on the vehicle shall conform to the dimensional and strength requirements in point 3.1 and point 3.2 and the requirements for the vertical load on the coupling point in point 3.3.
 - (e) in point 2.6, the first paragraph is replaced by the following:

For mechanical couplings on tractors, the drawbar ring shall be capable of tilting horizontally at least 60° on both sides of the longitudinal axis of a non-built-in coupling device. In addition, vertical mobility of 20° upwards and downwards is required at all times. (See also Appendix 1.)
 - (f) points 2.7 and 2.8 are replaced by the following:
 - 2.7. For mechanical couplings on tractors, the jaw shall permit the drawbar rings to swivel axially at least 90° to the right or left around the longitudinal axis of the coupling with a fixed braking momentum of between 30 and 150 Nm.

The towing hook, no-swivel clevis coupling, ball coupling and pin (piton) coupling shall allow the drawbar ring to swivel axially at least 20° to the right or left around the longitudinal axis of the coupling.
 - 2.8. For mechanical couplings on tractors, in order to prevent unintentional uncoupling from the hitch ring, the distance between the towing hook or ball head or pin (piton) tip and the keeper

Changes to legislation: There are currently no known outstanding effects for the
Commission Delegated Regulation (EU) 2016/1788. (See end of Document for details)

(clamping device) shall not exceed 10 mm at the maximum design load.

- (g) in point 3.3.1, the second sentence is replaced by the following:
- However, it shall not exceed 3 000 kg, except for the ball coupling, where the maximum value shall not exceed 4 000 kg.
- (h) in point 3.4.1, the first paragraph is replaced by the following:
- For mechanical couplings on tractors, all tractors with a technically permissible maximum laden mass exceeding 2,5 tonnes shall be fitted with a trailer coupling having a ground clearance satisfying one of the following relations:
- (i) points 4.1 and 4.2 are replaced by the following:
- 4.1. A vehicle representative of the vehicle type to be approved, on which a coupling device, duly approved, is mounted is submitted to the technical services responsible for conducting the type-approval tests.
- 4.2. The technical service responsible for conducting the type-approval tests checks whether the approved type of coupling device is suitable for mounting on the type of vehicle for which type-approval is requested. In particular, it ascertains that the attachment of the coupling device corresponds to that which was tested when the EU component type-approval was granted.
- (j) in point 4.3, the second indent is replaced by the following:
- a short technical description of the coupling device specifying the kind of construction and the material used,
- (k) points 4.5.2 and 4.5.3 are replaced by the following:
- 4.5.2. it is suitable for mounting on the type of vehicle for which the extension of the EU type-approval is requested;
- 4.5.3. the attachment of the coupling device on the vehicle corresponds to that which was presented when EU component type-approval was granted.
- (l) point 4.6 is replaced by the following:
- 4.6. A certificate, which template is set out in Annex V of Implementing Regulation (EU) 2015/504, is annexed to the EU type-approval certificate for each type-approval or type-approval extension which has been granted or refused.
- (m) point 4.7 is replaced by the following:
- 4.7. If the application for EU type-approval for a type of vehicle is made at the same time as the request for EU component type-approval for a coupling device on a vehicle for which EU type-approval is requested, then points 4.1 and 4.2 are unnecessary.
- (n) point 5.1.2 is replaced by the following:

- 5.1.2. EU component type-approval mark conforming to the model set out in Annex IV of Implementing Regulation (EU) 2015/504;
- (o) the following section 8 is added:

8. The following vehicles may be fitted with couplings intended to be connected with the three-point hitch or the lower link arms of the tractor:

- (a) vehicles of category Sa;
- (b) interchangeable towed equipment of category Ra intended mainly to process materials in the meaning of Article 3 (9) of Regulation (EU) No 167/2013;
- (c) vehicles of category Ra of a difference of laden and unladen mass of less than 2 tons.

If the vehicles referred to in the first paragraph are fitted with couplings intended to be connected with the three-point hitch or the lower link arms of the tractor, the parts of these systems shall meet the dimensional requirements of section 5 of ISO 730:2009, Amd.1: 2014.

The manufacturer's calculations or test results on the strength of the parts of the couplings, as part of compliance with Directive 2006/42/EC, shall be provided to the technical service, instead of the test results in point 3.2 of this Annex. The technical service shall verify the accuracy of the manufacturer's calculations or test results. Appropriate information with regard to safe coupling and fixing of the lower links vertically and laterally as well as the material quality of the spare parts and the permissible play shall be given in the operator's manual.

- (p) Appendix 1 is amended as follows:

- (i) the parts entitled 'Mechanical coupling types on tractors' and 'Mechanical coupling types on towed vehicles' are replaced by the following:

Mechanical couplings on agricultural and forestry vehicles

Mechanical couplings on tractors

"Clevis mechanical coupling": see Figures 1 and 2.

"No-swivel clevis mechanical coupling": see Figure 1d.

"Towing hook": see Figure 1 – "Hitch-hook dimensions" in ISO 6489-1:2001.

"Tractor drawbar": see Figure 3.

"Ball mechanical coupling": see Figure 4.

"Pin (piton) mechanical coupling": see Figure 5.

Changes to legislation: There are currently no known outstanding effects for the
Commission Delegated Regulation (EU) 2016/1788. (See end of Document for details)

Tractor drawbar dimensions shall comply with those of the following categories of ISO 6489-3:2004:

Category (0) (pin 18); compatible with ISO 5692-3, shape W (22 mm hole).

Category (1) (pin 30); compatible with ISO 5692-3, shape X (35 mm ring); ISO 5692-2:2002 (40 mm hole); ISO 8755:2001 (40 mm hole).

Category (2) (pin 30); compatible with ISO 5692-3, shape X (35 mm ring); ISO 5692-2:2002 (40 mm hole); ISO 8755:2001 (40 mm hole).

Category (3) (pin 38); compatible with ISO 5692-1:2004 (50 mm ring); ISO 5692-3:2011 shape Y (50 mm hole); ISO 20019:2001.

Category (4) (pin 50); compatible with ISO 5692-3:2011 shape Z (68 mm hole).

Mechanical couplings on towed vehicles

“Hitch rings” according to ISO 5692-1:2004 (50 mm hole, 30 mm ring diameter).

“Hitch rings” according to ISO 20019:2001 (50 mm hole centre, 30 to 41 mm ring diameter).

“Swivel hitch rings” according to ISO 5692-3:2011.

“Coupling rings” according to ISO 5692-2:2002 (40 mm socket).

“Drawbar eye” according to ISO 8755:2001 (40 mm hole).

“Drawbar eye” according to ISO 1102:2001 (50 mm hole).

“Coupling device” according to ISO 24347:2005 (80 mm ball diameter).

- (ii) the title of Figure 4 is replaced by the following:
Ball coupling (corresponding to ISO 24347:2005)
- (iii) the title of Figure 5 is replaced by the following:
Pin (piton) coupling (corresponding to ISO 6489-4:2004)
- (iv) Table 2 is replaced by the following:

TABLE 2

Coupling component on the tractor	Coupling component on the towed vehicle
Corresponding to ISO 6489-1:2001 (towing hook)	Corresponding to ISO 5692-1:2004 (hitch ring, 50 mm hole centre, 30 mm ring diameter)

Changes to legislation: There are currently no known outstanding effects for the Commission Delegated Regulation (EU) 2016/1788. (See end of Document for details)

	or to ISO 20019:2001 (hitch ring, 50 mm hole centre, 30 to 41 mm ring diameter) or to ISO 5692-3:2011 (swivel hitch rings; compatible only with shape Y, 50 mm hole)
Corresponding to ISO 6489-5:2011 (no-swivel clevis coupling)	Corresponding to ISO 5692-3:2011 (swivel hitch rings)
Corresponding to ISO 6489-2:2002 (clevis coupling)	Corresponding to ISO 5692-2:2002 (coupling ring, 40 mm socket) or to ISO 8755:2001 (40 mm drawbar eye) or to ISO 1102:2001 (50 mm drawbar eye, compatible only with ISO 6489-2:2002, shape A – non-automatic)
Corresponding to ISO 6489-3:2004 (drawbar)	Appropriate coupling mentioned in this column that fits the drawbar dimensions of the tractor mentioned in this Appendix or corresponding to Sa vehicles' hitch rings and attachment to tractor drawbars according to ISO 21244:2008.
Corresponding to ISO 24347:2005 (ball mechanical coupling)	Corresponding to ISO 24347:2005 (80 mm ball diameter)
Corresponding to ISO 6489-4:2004 (piton coupling)	Corresponding to ISO 5692-1:2004 (hitch ring, 50 mm hole centre, 30 mm ring diameter) or to ISO 5692-3:2011 (swivel hitch rings; compatible only with shape Y, 50 mm hole);

(q) Appendix 2 is amended as follows:

(i) in point 3.1, the first, the second and the third paragraphs are replaced by the following:

The test force shall be applied to the mechanical couplings being tested beneath an angle formed by the position of the vertical test load F_v vis-à-vis the horizontal test load F_h in the direction of the median longitudinal plane passing from top front to bottom rear.

The test force shall be applied at the usual point of contact between the mechanical coupling on the tractor and the corresponding one on the towed vehicle.

Changes to legislation: There are currently no known outstanding effects for the
Commission Delegated Regulation (EU) 2016/1788. (See end of Document for details)

The play between the mechanical coupling on the tractor and the corresponding one on the towed vehicle shall be kept to a minimum.

- (ii) in point 3.1, the fifth paragraph is replaced by the following:

Should the design of the mechanical coupling (e.g. excessive play, towing hook) make it impossible to carry out the test with an alternating test load, the test load may also be applied on a rising basis in the direction of traction or pressure, whichever is the greater.

- (iii) the following point 3.3 is added:

3.3. Load application

For components of the mechanical coupling on tractor or towed vehicle, the load is applied using the components of one corresponding mechanical coupling on respectively towed vehicle or tractor as permitted by the combinations listed in Table 2 of Appendix 1.

- (r) Appendix 3 is amended as follows:

- (i) point 1.2 is replaced by the following:

1.2. Test preparation

The tests shall be carried out on a special machine, with the mechanical coupling and any structure coupling it to the body of the vehicle attached to a rigid structure by means of the same components used to mount it on the vehicle.

- (ii) in point 1.4.2, the first paragraph is replaced by the following:

The data recorded for plotting the load/deformation curve under traction, or the graph of that curve provided by the printer linked to the traction machine, shall be based on the application of increasing loads only, starting from 500 daN, in relation to the reference centre of the mechanical coupling on tractor or towed vehicle.

- (iii) in point 1.5, the first paragraph is replaced by the following:

The test referred to in point 1.4.2 shall be preceded by a test in which a load of three times the maximum permissible vertical force (in daN, equal to $g \cdot S/10$) recommended by the manufacturer is applied in a gradually increasing manner, starting from an initial load of 500 daN, to the reference centre of the mechanical coupling on tractor or towed vehicle..

Changes to legislation: There are currently no known outstanding effects for the
Commission Delegated Regulation (EU) 2016/1788. (See end of Document for details)

- (1) [OJ L 60, 2.3.2013, p. 1.](#)
- (2) Commission Delegated Regulation (EU) No 1322/2014 of 19 September 2014 supplementing and amending Regulation (EU) No 167/2013 of the European Parliament and of the Council with regard to vehicle construction and general requirements for the approval of agricultural and forestry vehicles ([OJ L 364, 18.12.2014, p. 1.](#))
- (3) Commission Delegated Regulation (EU) 2015/208 of 8 December 2014 supplementing Regulation (EU) No 167/2013 of the European Parliament and of the Council with regard to vehicle functional safety requirements for the approval of agricultural and forestry vehicles ([OJ L 42, 17.2.2015, p. 1.](#))
- (4) Commission Delegated Regulation (EU) 2015/68 of 15 October 2014 supplementing Regulation (EU) No 167/2013 of the European Parliament and of the Council with regard to vehicle braking requirements for the approval of agricultural and forestry vehicles ([OJ L 17, 23.1.2015, p. 1.](#))
- (5) Commission Delegated Regulation (EU) 2015/96 of 1 October 2014 supplementing Regulation (EU) No 167/2013 of the European Parliament and of the Council as regards environmental and propulsion unit performance requirements of agricultural and forestry vehicles ([OJ L 16, 23.1.2015, p. 1.](#))
- (6) Directive 97/68/EC of the European Parliament and of the Council of 16 December 1997 on the approximation of the laws of the Member States relating to measures against the emission of gaseous and particulate pollutants from internal combustion engines to be installed in non-road mobile machinery ([OJ L 59, 27.2.1998, p. 1.](#))
- (7) Commission Delegated Regulation (EU) 2015/208 of 8 December 2014 supplementing Regulation (EU) No 167/2013 of the European Parliament and of the Council with regard to vehicle functional safety requirements for the approval of agricultural and forestry vehicles ([OJ L 42, 17.2.2015, p. 1.](#))
- (8) [OJ L 166, 30.6.2015, p. 170](#) ;
- (9) Commission Delegated Regulation (EU) No 1322/2014 of 19 September 2014 supplementing and amending Regulation (EU) No 167/2013 of the European Parliament and of the Council with regard to vehicle construction and general requirements for the approval of agricultural and forestry vehicles ([OJ L 364, 18.12.2014, p. 1.](#))
- (10) Commission Implementing Regulation (EU) 2015/504 of 11 March 2015 implementing Regulation (EU) No 167/2013 of the European Parliament and of the Council with regard to the administrative requirements for the approval and market surveillance of agricultural and forestry vehicles ([OJ L 85, 28.3.2015, p. 1.](#))
- (11) Commission Delegated Regulation (EU) 2015/208 of 8 December 2014 supplementing Regulation (EU) No 167/2013 of the European Parliament and of the Council with regard to vehicle functional safety requirements for the approval of agricultural and forestry vehicles ([OJ L 42, 17.2.2015, p. 1.](#))
- (12) Commission Implementing Regulation (EU) 2015/504 of 11 March 2015 implementing Regulation (EU) No 167/2013 of the European Parliament and of the Council with regard to the administrative requirements for the approval and market surveillance of agricultural and forestry vehicles ([OJ L 85, 28.3.2015, p. 1.](#))
- (13) Commission Delegated Regulation (EU) 2015/68 of 15 October 2014 supplementing Regulation (EU) No 167/2013 of the European Parliament and of the Council with regard to vehicle braking requirements for the approval of agricultural and forestry vehicles ([OJ L 17, 23.1.2015, p. 1.](#))
- (14) Commission Implementing Regulation (EU) 2015/504 of 11 March 2015 implementing Regulation (EU) No 167/2013 of the European Parliament and of the Council with regard to the administrative requirements for the approval and market surveillance of agricultural and forestry vehicles ([OJ L 85, 28.3.2015, p. 1.](#))
- (15) Commission Delegated Regulation (EU) 2015/68 of 15 October 2014 supplementing Regulation (EU) No 167/2013 of the European Parliament and of the Council with regard to vehicle braking requirements for the approval of agricultural and forestry vehicles ([OJ L 17, 23.1.2015, p. 1.](#))
- (16) Commission Delegated Regulation (EU) No 1322/2014 of 19 September 2014 supplementing and amending Regulation (EU) No 167/2013 of the European Parliament and of the Council with regard to vehicle construction and general requirements for the approval of agricultural and forestry vehicles ([OJ L 364, 18.12.2014, p. 1.](#))
- (17) As defined in Part A of Annex II to Directive 2007/46/EC.

Changes to legislation:

There are currently no known outstanding effects for the Commission Delegated Regulation (EU) 2016/1788.