

II

(Non-legislative acts)

REGULATIONS

COMMISSION DELEGATED REGULATION (EU) 2016/1824

of 14 July 2016

amending Delegated Regulation (EU) No 3/2014, Delegated Regulation (EU) No 44/2014 and Delegated Regulation (EU) No 134/2014 with regard, respectively, to vehicle functional safety requirements, to vehicle construction and general requirements and to environmental and propulsion unit performance requirements

(Text with EEA relevance)

THE EUROPEAN COMMISSION,

Having regard to the Treaty on the Functioning of the European Union,

Having regard to Regulation (EU) No 168/2013 of the European Parliament and of the Council of 15 January 2013 on the approval and market surveillance of two- or three-wheel vehicles and quadricycles ⁽¹⁾, and in particular Articles 18(3), 20(2), 21(5), 22(5), 23(12), 24(3), 25(8) and 54(3) thereof,

Whereas:

- (1) The Commission has kept track of issues encountered and pointed out by approval authorities and stakeholders in Regulation (EU) No 168/2013, as well as Commission Delegated Regulation (EU) No 3/2014 ⁽²⁾, Commission Delegated Regulation (EU) No 44/2014 ⁽³⁾ and Commission Delegated Regulation (EU) No 134/2014 ⁽⁴⁾ supplementing Regulation (EU) No 168/2013; in order to ensure accurate application of those Regulations, some of the issues identified should be addressed by way of amendments.
- (2) In order to ensure consistency and effectiveness of the EU type-approval system for L-category vehicles, it is necessary to continuously improve the technical requirements and test procedures set out in those delegated acts and adapt them to technical progress. It is also necessary improve the clarity of those delegated acts.
- (3) The following amendments to Delegated Regulation (EU) No 3/2014 with regard to technical requirements and test procedures in the area of vehicle functional safety should be included in the Annexes to that Delegated Regulation with a view to improving its consistency and clarity: the list set out in Annex I to Delegated Regulation (EU) No 3/2014 containing the applicable UNECE regulations should be updated and its Annex XV on tyre installation should be further clarified by adding the provisions on the manufacturer declaration with respect to the permissibility of the 'category of use' with checks performed accordingly. Further clarifications should be

⁽¹⁾ OJ L 60, 2.3.2013, p. 52.

⁽²⁾ Commission Delegated Regulation (EU) No 3/2014 of 24 October 2013 supplementing Regulation (EU) No 168/2013 of the European Parliament and of the Council with regard to vehicle functional safety requirements for the approval of two- or three-wheel vehicles and quadricycles (OJ L 7, 10.1.2014, p. 1).

⁽³⁾ Commission Delegated Regulation (EU) No 44/2014 of 21 November 2013 supplementing Regulation (EU) No 168/2013 of the European Parliament and of the Council with regard to the vehicle construction and general requirements for the approval of two- or three- wheel vehicles and quadricycles (OJ L 25, 28.1.2014, p. 1).

⁽⁴⁾ Commission Delegated Regulation (EU) No 134/2014 of 16 December 2013 supplementing Regulation (EU) No 168/2013 of the European Parliament and of the Council with regard to environmental and propulsion unit performance requirements and amending Annex V thereof (OJ L 53, 21.2.2014, p. 1).

added to Annex XVII to Delegated Regulation (EU) No 3/2014 regarding interior fittings, to its Annex XVIII with regard to maximum power limitation and to its Annex XIX with respect to structural integrity requirements, in particular those for powered cycles in the scope of Regulation (EU) No 168/2013.

- (4) For the purposes of completeness and accuracy, it is appropriate that the list of UNECE regulations that apply on a compulsory basis set-out in Annex I to Delegated Regulation (EU) No 3/2014 includes UNECE Regulations Nos 1, 3, 6, 7, 8, 16, 19, 20, 28, 37, 38, 39, 43, 46, 50, 53, 56, 57, 60, 72, 74, 75, 78, 81, 82, 87, 90, 98, 99, 112 and 113.
- (5) The following amendments to Delegated Regulation (EU) No 44/2014 should be made in order to improve consistency and accuracy: Annex I to Delegated Regulation (EU) No 44/2014 contains a list of applicable UNECE regulations, which should be updated; Annex II to Regulation (EU) No 44/2014 should be supplemented with respect to marking requirements for parts, equipment and components for the purposes of identification and prevention of tampering; Annex III to that Delegated Regulation should be amended to provide clarifications on the requirements concerning the conversion of vehicles of subcategories L3e/L4e-A2 into A3 motorcycles and vice versa; certain amendments should be made in Annex XI to Delegated Regulation (EU) No 44/2014 on masses and dimensions, in particular relating to the ground clearance definition of subcategories L3e-AxE (Enduro motorcycle) and L3e-AxT (Trial motorcycle); Annex XII to Delegated Regulation (EU) No 44/2014 should be amended as regards the standardised on-board diagnostics connection interface; and certain clarifications should be made in Annex XVI to the same Delegated Regulation on stands for these motorcycle subcategories.
- (6) On-board diagnostics ('OBD') is essential for effective and efficient repair and maintenance of vehicles. Accurate diagnostics allow the repairer to identify fast which smallest exchangeable unit has to be repaired or replaced. In order to address the rapid technical developments in the area of propulsion control systems it is appropriate to review the list of devices monitored for electric circuit malfunctions in 2017. By 31 December 2018, it should be established whether additional devices and malfunctions should be added to the list set out in Appendix 2 to Annex XII to Delegated Regulation (EU) No 44/2014 provide sufficient time to the Member States, vehicle manufacturers, their suppliers and the repair industry to adapt before the entry into force of OBD stage II. PID \$1C on the applicable on-board diagnostic system may be programmed to \$00 or \$FF as long as its value has not been standardised for L-category vehicles. For the purposes of consistency and completeness, as the publication date of the revised standard ISO 15031-5:20xx containing such a standardised value dedicated to L-category vehicles, this standardised value should be programmed as response to the PID \$1C request of a generic scan tool.
- (7) For the purposes of completeness and consistency, certain equations should be adapted in Annexes II and V to Delegated Regulation (EU) No 134/2014; in Annex VI to that Delegated Regulation regarding the durability of pollution control devices, the classification criteria of the SRC-LeCV distance accumulation cycle should be adapted to technical progress; finally, Annex IX to Delegated Regulation (EU) No 134/2014 should be amended to take into account some of the anti-tampering provisions set out in UNECE Regulations Nos 9, 41, 63 and 92 in the area of sound approval, in particular for multi-mode sound systems.
- (8) One of the measures against excessive hydrocarbon emissions from L-category vehicles is to limit the evaporative emissions to the hydrocarbon mass limits laid down in Annex VI(C) to Regulation (EU) No 168/2013. For this purpose, a type IV test has to be conducted at type-approval in order to measure the evaporative emissions of a vehicle. One of the requirements of the type IV Sealed House evaporative Emission Determination (SHED) test is to fit either a rapidly aged carbon canister or alternatively to apply an additive deterioration factor when fitting a degreened carbon canister. It will be investigated in the environmental effect study referred to in Article 23(4) of Regulation (EU) No 168/2013 whether or not it is cost beneficial to maintain this deterioration factor as alternative to fitting a representative and rapidly aged carbon canister. If the result of the study demonstrates that this method is not cost-beneficial a proposal will follow in due course to delete this alternative and should become applicable beyond the Euro 5 step.
- (9) A standardised method for measuring vehicles' energy efficiency (fuel or energy consumption, carbon dioxide emissions as well as electric range) is necessary to ensure that no technical barriers to trade arise between Member States and also to ensure that customers and users are supplied with objective and precise information. Until a harmonised test procedure is agreed upon for category L1e vehicles designed to pedal, referred to in Annex I to Regulation (EU) No 168/2013 and in point 1.1.2 of Annex XIX to Delegated Regulation (EU) No 3/2014, those category L1e vehicles should be exempted from the electric range test.

- (10) Delegated Regulation (EU) No 3/2014, Delegated Regulation (EU) No 44/2014 and Delegated Regulation (EU) No 134/2014 should therefore be amended accordingly.
- (11) Given that Regulation (EU) No 168/2013, Delegated Regulation (EU) No 3/2014, Delegated Regulation (EU) No 44/2014 and Delegated Regulation (EU) No 134/2014 are already applicable and that the amendments to those acts include number of corrections, this Regulation should enter into force as soon as possible,

HAS ADOPTED THIS REGULATION:

Article 1

Delegated Regulation (EU) No 3/2014 is amended as follows:

- (1) in Article 3(2), 'Manufacturers' is replaced by 'Manufacturers of parts and equipment';
- (2) the Annexes are amended in accordance with Annex I to this Regulation.

Article 2

Delegated Regulation (EU) No 44/2014 is amended as follows:

- (1) in Article 3(2), 'Manufacturers' is replaced by 'Manufacturers of parts and equipment';
- (2) the Annexes are amended in accordance with Annex II to this Regulation.

Article 3

Delegated Regulation (EU) No 134/2014 is amended as follows:

- (1) Article 2 is amended as follows
- (a) in point (16), 'ehaust' is replaced by 'exhaust';
- (b) point (42) is replaced by the following:
- '(42) "maximum thirty minutes speed" of a vehicle means the maximum achievable vehicle speed measured during 30 minutes as a result of the 30 minute power set out in UNECE regulation No 85 (*);
- (*) OJ L 326, 24.11.2006, p. 55.;
- (2) in Article 3(4), 'manufacturer' is replaced by 'manufacturer of parts and equipment';
- (3) the Annexes are amended in accordance with Annex III to this Regulation.

Article 4

This Regulation shall enter into force on the first day following that of its publication in the *Official Journal of the European Union*.

This Regulation shall be binding in its entirety and directly applicable in all Member States.

Done at Brussels, 14 July 2016.

For the Commission
The President
Jean-Claude JUNCKER

ANNEX I

Amendments to Delegated Regulation (EU) No 3/2014

The Annexes to Delegated Regulation (EU) No 3/2014 are amended as follows:

- (1) Annex I is replaced by the following:

ANNEX I

List of UNECE regulations which apply on a compulsory basis

UNECE regulation No	Subject	Series of amendments	OJ reference	Applicability
1	Headlamps for motor vehicles (R2, HS1)	02	OJ L 177, 10.7.2010, p. 1.	L1e, L2e, L3e, L4e, L5e, L6e and L7e
3	Retro-reflectors	Supplement 12 to the 02 series of amendments	OJ L 323, 6.12.2011, p. 1.	L1e, L2e, L3e, L4e, L5e, L6e and L7e
6	Direction indicators	Supplement 25 to the 01 series of amendments	OJ L 213, 18.7.2014, p. 1.	L1e, L2e, L3e, L4e, L5e, L6e and L7e
7	Front and rear position lamps and stop lamps	Supplement 23 to the 02 series of amendments	OJ L 285, 30.9.2014, p. 1.	L1e, L2e, L3e, L4e, L5e, L6e and L7e
8	Head lamps for motor vehicles (H1, H2, H3, HB3, HB4, H7, H8, H9, H11, HIR1, HIR2)	05	OJ L 177, 10.7.2010, p. 71.	L1e, L2e, L3e, L4e, L5e, L6e and L7e
16	Safety belts, restraint systems and child restraint systems	Supplement 5 to the 06 series of amendments	OJ L 304, 20.11.2015, p. 1.	L2e, L4e, L5e, L6e and L7e
19	Front fog lamps	Supplement 6 to the 04 series of amendments	OJ L 250, 22.8.2014, p. 1.	L3e, L4e, L5e and L7e
20	Headlamps for motor vehicles (H4)	03	OJ L 177, 10.7.2010, p. 170.	L1e, L2e, L3e, L4e, L5e, L6e and L7e
28	Audible warning devices	Supplement 3 to the 00 series of amendments	OJ L 323, 6.12.2011, p. 33.	L3e, L4e and L5e
37	Filament bulbs	Supplement 42 to the 03 series of amendments	OJ L 213, 18.7.2014, p. 36.	L1e, L2e, L3e, L4e, L5e, L6e and L7e

UNECE regulation No	Subject	Series of amendments	OJ reference	Applicability
38	Rear fog lamps	Supplement 15 to the 00 series of amendments	OJ L 4, 7.1.2012, p. 20.	L3e, L4e, L5e and L7e
39	Uniform provisions concerning the approval of vehicles with regard to the speedometer equipment including its installation	Supplement 5 to the original version of the Regulation	OJ L 120, 13.5.2010, p. 40.	L1e, L2e, L3e, L4e, L5e, L6e and L7e
43	Safety glazing	Supplement 2 to the 01 series of amendments	OJ L 42, 12.2.2014, p. 1.	L1e, L2e, L3e, L4e, L5e, L6e and L7e
46	Devices for indirect vision (rear-view mirrors)	Supplement 1 to the 04 series of amendments	OJ L 237, 8.8.2014, p. 24.	L2e, L5e, L6e and L7e
50	Lighting components for vehicles of category L	Supplement 16 to the 00 series of amendments	OJ L 97, 29.3.2014, p. 1.	L1e, L2e, L3e, L4e, L5e, L6e and L7e
53	Installation of lighting (motorcycle)	Supplement 14 to the 01 series of amendments	OJ L 166, 18.6.2013, p. 55.	L3e
56	Headlamps for mopeds and vehicles treated as such	01	OJ L 89, 25.3.2014, p. 1.	L1e, L2e and L6e
57	Headlamps for motorcycles and vehicles treated as such	02	OJ L 130, 1.5.2014, p. 45.	L3e, L4e, L5e and L7e
60	Identification of controls tell-tales and indicators	Supplement 4 to the 00 series of amendments	OJ L 297, 15.10.2014, p. 23.	L1e and L3e
72	Headlamps for motorcycles and vehicles treated as such (HS1)	01	OJ L 75, 14.3.2014, p. 1.	L3e, L4e, L5e and L7e
74	Installation of lighting (moped)	Supplement 7 to the 00 series of amendments	OJ L 166, 18.6.2013, p. 88.	L1e
75	Tyres	Supplement 13 to the 01 series of amendments	OJ L 84, 30.3.2011, p. 46.	L1e, L2e, L3e, L4e and L5e
78	Braking, including anti-lock and combined brake systems	Corrigendum 2 to the 03 series of amendments	OJ L 24, 30.1.2015, p. 30.	L1e, L2e, L3e, L4e and L5e
81	Rear-view mirrors	Supplement 2 to the 00 series of amendments	OJ L 185, 13.7.2012, p. 1.	L1e, L2e, L3e, L4e, L5e, L6e and L7e

UNECE regulation No	Subject	Series of amendments	OJ reference	Applicability
82	Headlamps for mopeds and vehicles treated as such (HS2)	01	OJ L 89, 25.3.2014, p. 92.	L1e, L2e and L6e
87	Daytime running lamps	Supplement 15 to the 00 series of amendments	OJ L 4, 7.1.2012, p. 24.	L1e, L2e, L3e, L4e, L5e, L6e and L7e
90	Replacement brake lining assemblies and drum brake linings	02	OJ L 185, 13.7.2012, p. 24.	L1e, L2e, L3e, L4e, L5e, L6e and L7e
98	Headlamps with gas-discharge light sources	Supplement 4 to the 01 series of amendments	OJ L 176, 14.6.2014, p. 64.	L3e
99	Gas-discharge light sources	Supplement 9 to the 00 series of amendments	OJ L 285, 30.9.2014, p. 35.	L3e
112	Headlamps with asymmetrical beams	Supplement 4 to the 01 series of amendments	OJ L 250, 22.8.2014, p. 67.	L1e, L2e, L3e, L4e, L5e, L6e and L7e
113	Headlamps with symmetrical beams	Supplement 3 to the 01 series of amendments	OJ L 176, 14.6.2014, p. 128.	L1e, L2e, L3e, L4e, L5e, L6e and L7e

Explanatory note: The fact that a component is included in this list does not make its installation mandatory. For certain components, however, mandatory installation requirements are laid down in other annexes to this Regulation.;

(2) Annex IV is amended as follows:

(a) point 4.1.4. is replaced by the following:

'4.1.4. If the on-board REESS can be externally charged by the driver, vehicle movement by its own propulsion system shall be impossible as long as the connector of the external electric power supply is physically connected to the vehicle inlet. For vehicles of category L1e with a mass in running order \leq 35 kg vehicle movement by its own propulsion system shall be inhibited as long as the connector of the battery charger is physically connected to the external electric power supply. Compliance with this requirement shall be demonstrated by using the connector or battery charger specified by the vehicle manufacturer. In case of permanently connected charge cables, the requirement above is deemed to be met when use of the charge cable obviously prevents the use of the vehicle (e.g. cable is always routed over operator controls, rider's saddle, driver's seat, handle bar or steering wheel, or the seat covering the cable storage space needs to remain in open position).';

(b) point 4.3. is replaced by the following:

'4.3 Driving backwards

It shall not be possible to activate the vehicle reverse control function in an uncontrolled manner whilst the vehicle is in forward motion, insofar as such activation could cause a sudden and strong deceleration or wheel lock. However, it may be possible for the vehicle reverse control function to be activated in such a way that it may slow down the vehicle gradually.;

(3) in Annex VII, in Part 1, point 1.1.1. is replaced by the following:

‘1.1.1. All safety glazing fitted to the vehicle shall be type-approved in accordance with UNECE regulation No 43 (*).

(*) OJ L 42, 12.2.2014, p. 1.’;

(4) Annex VIII is amended as follows:

(a) points 1.1.1.1. and 1.1.1.2. are replaced by the following:

‘1.1.1.1. It shall be ensured that no deviations in the shape and orientation of the provided symbols are permitted, notably that any customised appearance of the provided symbols shall be prohibited.

1.1.1.2. Small irregularities concerning line thickness, the marking application and other relevant production tolerances shall be accepted, as provided in paragraph 4 of ISO 2575:2010/Amd1:2011 (design principles).’;

(b) point 2.1.3. is replaced by the following:

‘2.1.3. It shall be ensured that no deviations in the shape and orientation of the provided symbols are permitted, notably that any customised appearance of the provided symbols shall be prohibited.

Small irregularities concerning line thickness, the marking application and other relevant production tolerances shall be accepted, as provided in paragraph 4 of ISO 2575:2010/Amd1:2011 (design principles).’;

(5) Annex IX is amended as follows:

(a) point 1.12 is replaced by the following:

‘1.12 Where automatically switched-on headlamp or daytime running lamp activation is linked to the running of an engine, this shall be construed, for vehicles with electric or other alternative propulsion unit systems and vehicles equipped with an automatic stop/start system of the propulsion unit, as being linked to the master control switch having been activated with the vehicle in normal operation mode.’;

(b) point 2.3.11.8. is replaced by the following:

‘2.3.11.8. Other requirements:

— in the absence of prescriptions for reversing lamp lighting devices which can be type-approved for vehicles of category L, the reversing lamp shall be type-approved according to UNECE regulation No 23 (*).

(*) OJ L 237, 8.8.2014, p. 1’;

(c) point 2.3.15.8. is replaced by the following:

‘2.3.15.8. Other requirements:

— in the absence of prescriptions for side marker lamp lighting devices which can be type-approved for vehicles of category L, the lamps shall be type-approved according to UNECE regulation No 91 (*).

(*) OJ L 4, 7.1.2012, p. 27’;

(6) Annex XV is amended as follows:

(a) points 1.1. and 1.1.1. are replaced by the following:

‘1.1. Subject to the provisions of points 1.1.1. to 1.1.2., all tyres fitted to vehicles, including any spare tyre, shall be type-approved according to UNECE regulation No 75.

1.1.1. Where a vehicle is designed for conditions of use which are incompatible with the characteristics of tyres type-approved according to UNECE regulation No 75 as applicable in the Union legislation at the time of type-approval testing of the vehicle and it is therefore necessary to fit tyres with different characteristics, the requirements of point 1.1. do not apply, provided that the following conditions are met:

— the tyres are type-approved according to Council Directive 92/23/EEC (*), Regulation (EC) No 661/2009 of the European Parliament and of the Council (**), or UNECE regulation No 106; and

— the approval authority and technical service are satisfied that the tyres fitted are suitable for the operating conditions of the vehicle. The nature of this exemption and reasons for acceptance shall be clearly stated in the test report.

(*) Council Directive 92/23/EEC of 31 March 1992 on tyres for motor vehicles and their trailers (OJ L 129, 14.5.1992, p. 95).

(**) Regulation (EC) No 661/2009 of the European Parliament and of the Council of 13 July 2009 concerning type-approval requirements for the general safety of motor vehicles, their trailers and systems, components and separate technical units intended therefor (OJ L 200, 31.7.2009, p. 1).’;

(b) point 1.2. is deleted;

(c) point 2.2. is replaced by the following:

‘2.2. The vehicle manufacturer may restrict the category of use of original and replacement tyres that may be installed on the vehicle. In this case, the categories of use of tyres that may be fitted to the vehicle shall be clearly stated in the vehicle’s instruction manual.’;

(d) point 2.2.1. is deleted;

(e) point 2.3 is replaced by the following:

‘2.3. The space in which each wheel revolves shall be such as to allow unrestricted movement when using the maximum permissible size of tyres and rim widths, taking into account the minimum and maximum wheel off-sets if applicable, within the minimum and maximum suspension and steering constraints as declared by the vehicle manufacturer. This shall be verified by performing the checks for the largest and the widest tyre in each space, taking into account the applicable rim size and the maximum allowed section width and outer diameter of the tyre, in relation to the tyre size designation as specified in the applicable legislation. The checks shall be performed by rotating a representation of the tyre’s permissible overall dimensions in the form of a maximum envelope, not just the actual tyre, in the space for the wheel in question.’;

(f) the following points 2.3.1., 2.3.2. and 2.4 are inserted:

‘2.3.1. All tyres that may be fitted to the vehicle in accordance with point 2.2. shall be taken into account for the determination of the permissible overall dimensions (i.e. the maximum envelope) of the relevant tyre, as applicable in the Union legislation at the time of type-approval testing of the vehicle. For this purpose, either the specifications as provided for in Annex 5 of UNECE Regulation No 75 or the permitted percentages as provided for sizes not included in that Annex shall be taken into account (e.g. overall width of multiservice tyres (MST) + 25 %, normal and snow service tyres + 10 % in case of rim diameter code 13 and above and + 8 % in case of rim diameter codes up to 12 inclusive).

2.3.2. In addition, the permissible dynamic growth of the height of bias and bias/belted construction tyres which are type-approved according to UNECE regulation No 75 depends on the speed category and the category of use of the tyre. To ensure an appropriate selection of bias and bias/belted replacement tyres for the end-user of the vehicle, the vehicle manufacturer shall take into account both the permitted categories of use as well as the speed category that is compatible with the maximum design vehicle speed, for the determination of the permitted tolerance laid down in point 4.1. of Annex 9 to UNECE regulation No 75 (i.e. $H_{dyn} = H \times 1,10$ up to $H_{dyn} = H \times 1,18$). More stringent categories may be taken into account at the discretion of the vehicle manufacturer.

2.4. The technical service may agree to an alternative test procedure (e.g. virtual testing) to verify that the requirements of point 2.3. to 2.3.2. are met, provided that the clearance between the tyre's maximum envelope and vehicle structure exceeds 10 mm at all points.;

(g) point 4.2.2. is replaced by the following:

‘4.2.2. In the case of vehicles normally equipped with ordinary tyres and occasionally fitted with snow tyres, where the speed category symbol of the snow tyre shall correspond to a speed either greater than the maximum design vehicle speed or not less than 130 km/h (or both). However, if the maximum design vehicle speed is greater than the speed corresponding to the lowest speed category symbol of the fitted snow tyres, a maximum speed warning label, specifying the lowest value of the maximum speed capability of the fitted snow tyres or the manufacturer's recommended speed for the vehicle (whichever is lower), shall be displayed inside the vehicle in a prominent position or, if the vehicle does not have an interior, as close as possible to the instrument cluster, readily and permanently visible to the driver.’;

(7) Annex XVI is amended as follows:

(a) point 2.1 is replaced by the following:

‘2.1. All characters on the plate shall be formed by retro-reflective material type-approved as Class D, E or D/E according to UNECE regulation No 104 (*).

(*) OJ L 75, 14.3.2014, p. 29’;

(b) point 3.3.1. is replaced by the following:

‘3.3.1. The plate shall be perpendicular, $\pm 5^\circ$, to the longitudinal plane of the vehicle.’;

(c) in point 3.6.1, the first indent is replaced by the following:

‘— the two vertical planes touching the two lateral edges of the plate and forming an angle measured outwards to the left and to the right of the plate of 30° in relation to the longitudinal plane, parallel to the longitudinal median plane of the vehicle, passing through the centre of the plate’;

(d) in point 3.6.2, the first indent is replaced by the following:

‘— the two vertical planes touching the two lateral edges of the plate and forming an angle measured outwards to the left and to the right of the plate of 30° in relation to the longitudinal plane, parallel to the longitudinal median plane of the vehicle, passing through the centre of the plate’;

(8) Annex XVII is amended as follows:

(a) the following point 1.1.6.3.1. is inserted:

‘1.1.6.3.1. However, in case the level of the instrument panel is located above the level of the horizontal plane coinciding with the R-point of the seating position of the driver, a knee-form testing apparatus shall be used above the upper horizontal boundary of interior zone 2 to assess contactable edges of the

instrument panel, as well as any elements mounted directly onto it, located below the level of the instrument panel. The technical service shall clearly indicate in the test report which parts of the interior are deemed to be instrument panel and relevant elements, in agreement with the type-approval authority. The steering control shall be disregarded for the determination of the level of the instrument panel.;

(b) the following point 2.1.8. is inserted:

'2.1.8. Contactable edges of type-approved interior rear-view mirrors (Class I) are deemed to comply with the requirements of this Annex.;

(c) point 2.2.1. is replaced by the following:

'2.2.1. In this zone, as well as that covered by point 1.1.6.3.1., a knee-form testing apparatus shall be moved from any given starting location in a horizontal and forward direction, while the orientation of the X-axis of the device may be varied within the specified limits. All contactable edges, except those mentioned below, shall be rounded with a radius of curvature of at least 3.2 mm. Contacts made with the rear face of the device shall be disregarded.;

(d) the following points 2.4., 2.4.1. and 2.4.2. are added:

'2.4. Interior zones 1, 2 and 3

2.4.1. Radii of contactable edges that cannot be determined accurately with the use of conventional measuring tools (e.g. radius gauge) due to oblique corners, limited protrusions, character or style lines, ribs and bumps as well as surface graining, are deemed in compliance with the requirements provided that such edges are at least blunted.

2.4.2. The vehicle manufacturer may as an alternative choose to apply in full all relevant requirements of UNECE regulation No 21 (*) as prescribed for vehicle category M1, covering the entire, not just portions, of the interior.

(*) OJ L 188, 16.7.2008, p. 32.;

(9) Annex XVIII is amended as follows:

(a) point 1.1.2.1.1. is replaced by the following:

'1.1.2.1.1. Adjustment of the spark properties, including timing and/or presence, in order to limit the maximum design vehicle speed and/or maximum power shall be allowed for (sub)categories L3e-A2 (only if maximum net power ≥ 20 kW), L3e-A3, L4e-A, L5e, L6eB and L7eC. It may also be allowed for other (sub)categories provided that the adjustment concept does not negatively affect emission of gaseous pollutants, CO₂ emissions and fuel consumption while at maximum design vehicle speed and/or maximum power conditions which shall be verified by the technical service.;

(b) point 1.1.2.5. is replaced by the following:

'1.1.2.5. At least two of the limitation methods used, as referred to in points 1.1.2.1 to 1.1.2.4., shall operate independently of each other, be different in nature and have different design philosophies, although they may apply similar elements (e.g. both methods based on the notion of rotation speed as a criterion, but one measured inside a motor and the other in the drive-train's transmission). Failure of one method to work as intended (e.g. due to tampering) shall not impair the limitation function of other methods. In this case, the maximum power and/or vehicle speed which can be attained may be lower than under normal conditions. Without prejudice to the conformity of production tolerance set

out in point 4.1.4. of Annex IV to Regulation (EU) No 44/2014, the maximum power and/or vehicle speed may not be higher than demonstrated at type-approval, if one out of the two redundant limitation methods is eliminated.’;

(c) the following points 1.1.2.6. to 1.1.2.9. are inserted:

‘1.1.2.6. The vehicle manufacturer shall be allowed to make use of limitation methods other than those listed in points 1.1.2.1 to 1.1.2.4. if the manufacturer can prove to the technical service and to the satisfaction of the type approval authority that those alternative limitation methods meet the principles of redundancy set out in point 1.1.2.5. and provided that at least one of the parameters listed in points 1.1.2.1., 1.1.2.2. or 1.1.2.3. (e.g. limitation of fuel mass, air mass, spark delivery and drivetrain rotation limitation) is applied in one of the limitation methods.

1.1.2.7. The manufacturer shall be allowed to combine two or more of the individual limitation methods referred to in points 1.1.2.1 to 1.1.2.4. as part of a limitation strategy. Such combination of limitation methods shall be regarded as a single limitation method within the meaning of point 1.1.2.5.

1.1.2.8. Individual limitation methods or combinations of the limitation methods referred to in points 1.1.2.1 to 1.1.2.4. may be applied more than once provided that their multiple uses operate independently of each other, as required by point 1.1.2.5., so that failure of one of the methods to work as intended (e.g. due to tampering) does not impair the functioning in another application, of the same limitation method or combination of methods.

1.1.2.9. A limitation strategy that in case of failure (e.g. due to tampering) includes the activation of a special operating (e.g. ‘limp home’) mode with substantially reduced maximum vehicle speed and/or maximum power not suitable for normal operation or that activates an ignition interlock preventing the engine from running for as long as the failure remains, shall be regarded as one limitation method.’;

(d) point 1.1.4. is replaced by the following:

‘1.1.4. The provision and use of any other means enabling the vehicle operator to directly or indirectly adjust, set, select or alter the maximum propulsion unit performance determined on the basis of the information submitted in accordance with Annex I, Part B, point 2.8., items 1.8.2. to 1.8.9. of Regulation (EU) No 901/2014 (e.g. high performance switch, special encoded recognition transponder in ignition key, physical or electronic jumper setting, selectable option through electronic menu, programmable feature of control unit) resulting in exceedance is prohibited.’;

(e) point 2.1. is replaced by the following:

‘2.1. The vehicle manufacturer shall demonstrate compliance with the specific requirements of points 1.1 to 1.1.2.9 by proving that two or more of the methods implemented, by integrating specific devices and/or functions in the vehicle propulsion system, ensure the required maximum continuous rated or net power and/or maximum vehicle speed limitation and that each method does so in a fully independent manner.’;

(10) Annex XIX is amended as follows:

(a) point 1.1.1. of is replaced by the following:

‘1.1.1. Vehicles of category L1e-A and cycles designed to pedal of vehicle category L1e-B shall be designed and constructed as to conform with all prescriptions regarding requirements and test methods laid down for handlebar stem-assembly, seat-post, front forks and frames as encompassed in standard ISO 4210:2014, irrespective of any scope mismatch in that technical standard. The minimum value of the required test forces shall be in accordance with Table 19-1 in point 1.1.1.1.’;

(b) the following point 1.1.1.1. is inserted:

1.1.1.1.

Table 19-1

Test and minimum forces or number of test cycles for vehicles of category L1e-A and cycles designed to pedal of vehicle category L1e-B

Subject	Name of test	Reference of test which shall be used	Minimum value of the required test force or minimum number of test cycles
Handlebar and stem	Lateral bending test (static test)	ISO 4210-5:2014, test method 4.3	800 N (= Force, F_2)
	Fatigue test (Stage 1 — Out of phase loading)	ISO 4210-5:2014, test method 4.9	270 N (= Force, F_6)
	Fatigue test (Stage 2 — In phase loading)	ISO 4210-5:2014, test method 4.9	2014, test method 4.9 370 N (= Force, F_7)
Frame	Fatigue test with pedalling forces	ISO 4210-6:2014, test method 4.3	1 000 N (= Force, F_1)
	Fatigue test with horizontal forces	ISO 4210-6:2014, test method 4.4	C1 = 100 000 (= Number of test cycles)
	Fatigue test with a vertical force	ISO 4210-6:2014, test method 4.5	1 100 N (= Force, F_4)
Front fork	Static bending test	ISO 4210-6:2014, test method 5.3	1 500 N (= Force, F_3)
Seat-post	Stage 1, fatigue test	ISO 4210-9:2014, test method 4.5.2	1 100 N (= Force, F_3)
	Stage 2, static strength test	ISO 4210-9:2014, test method 4.5.3	2 000 N (= Force, F_4)

(c) in point 1.2, 'drivetrain' is replaced by 'powertrain'.

ANNEX II

Amendments to Delegated Regulation (EU) No 44/2014

The Annexes to Delegated Regulation (EU) No 44/2014 are amended as follows:

- (1) Annex I is replaced by the following:

‘ANNEX I

List of UNECE regulations which apply on a compulsory basis

UNECE regulation No	Subject	Series of amendments	OJ reference	Applicability
10	Electromagnetic compatibility (EMC)	Supplement 1 to the 04 series of amendments	OJ L 254, 20.9.2012, p. 1.	L1e, L2e, L3e, L4e, L5e, L6e and L7e
62	Protection against unauthorised use	Supplement 2 to the 00 series of amendments	OJ L 89, 27.3.2013, p. 37.	L1e, L2e, L3e, L4e, L5e, L6e and L7e

Explanatory note: The fact that a component is included in this list does not make its installation mandatory. For certain components, however, mandatory installation requirements are laid down in other annexes to this Regulation.’;

- (2) Annex II is amended as follows:

(a) in point 2.3.1.1., ‘cylinder/piston combination’ is replaced by ‘cylinder, piston’;

(b) in point 2.3.1.2., ‘cylinder/piston combination’ is replaced by ‘cylinder, piston’;

(c) point 3.2.1.3. is replaced by the following:

‘3.2.1.3. A marking with indication of the vehicle (sub-) category as defined in Articles 2 and 4 of, and Annex I to, Regulation (EU) No 168/2013 shall be legible on the pipes.’;

(d) the following point 3.2.2.5. is inserted:

‘3.2.2.5. For two-stroke engines, the maximum thickness of any gasket between the base of the cylinder and the crankcase, if any, may not exceed 0,5 mm, after mounting.’;

(e) the following points 3.3., 3.3.1. and 3.3.2. are inserted:

‘3.3. Continuous Variable Transmission (CVT)

3.3.1. CVT Transmission covers, if available, shall be fixed by means of at a minimum 2 shear bolts or be disassembled only by using special tools.

3.3.2. The CVT mechanism intended to limit the drive ratio by limitation of the effective distance between two discs shall be fully integrated in one or both discs in such a way that it is impossible to modify the effective distance beyond a limit that would result in an increase of the maximum vehicle speed of more than 10 % of this maximum permissible vehicle speed without destroying the disc system. If the manufacturer employs interchangeable spacer rings in the CVT to adjust the maximum vehicle speed, the complete removal of these rings shall not increase the maximum vehicle speed with more than 10 %.’;

- (f) points 3.5., 3.5.1 and 3.5.2. are deleted;
- (g) points 4. to 4.2.3. are replaced by the following:

4. Additional specific requirements for (sub-) categories L3e-A1 and L4e-A1

4.1 Subcategory L3e-A1 and L4e-A1 vehicles shall comply with the requirements of either points 4.2. to 4.2.3., or points 4.3., 4.3.1. and 4.3.2., or points 4.4., 4.4.1. and 4.4.2., and with points 4.5., 4.6. and 4.7. In addition, they shall comply the requirements of points 3.2.2.1., 3.2.2.3., 3.2.2.4., 3.2.2.5., 3.2.3.1. and 3.2.3.3.

4.2. An irremovable sleeve must be located in the inlet conduit. If such a sleeve is located in the intake pipe, the latter shall be fixed to the engine block by means of shear-bolts or bolts removable only using special tools.

4.2.1. The sleeve shall have a minimum hardness of 60 HRC. In the restricted section it shall not exceed 4 mm in thickness.

4.2.2. Any interference with the sleeve aimed at removing or modifying it shall lead to either the destruction of the sleeve and its support or complete and permanent malfunctioning of the engine until it is restored to its approved condition.

4.2.3. A marking with indication of the vehicle (sub-) category as defined in Articles 2 and 4 of, and Annex I to, Regulation (EU) No 168/2013 shall be legible on the surface of the sleeve or not far from it.;

- (h) points 4.2.4. to 4.2.12. are deleted;

- (i) the following points 4.3. to 4.7. are inserted:

4.3. Each intake pipe shall be fixed with shear-bolts or bolts removable only using special tools. A restricted section, indicated on the outside, shall be located inside the pipes; at that point the wall shall be less than 4 mm in thickness, or 5 mm if composed of a flexible material such as rubber.

4.3.1. Any interference with the pipes aimed at modifying the restricted section shall lead to either the destruction of the pipes or complete and permanent malfunctioning of the engine until they are restored to their approved condition.

4.3.2. A marking with indication of the vehicle (sub-) category as defined in Articles 2 and 4 of, and Annex I to, Regulation (EU) No 168/2013 shall be legible on the pipes.

4.4. The part of the inlet conduit located in the cylinder head shall have a restricted section. In the whole inlet passage, there shall not be a more restricted section (except the valve-seat section).

4.4.1. Any interference with the conduit aimed at modifying the restricted section shall lead to either the destruction of the pipe or complete and permanent malfunctioning of the engine until it is restored to its approved condition.

4.4.2. A marking with indication of the vehicle category as defined in Articles 2 and 4 of, and Annex I to, Regulation (EU) No 168/2013 shall be legible on the cylinder head.

4.5. The diameter of the restricted sections referred to in point 4.2. may vary according to the (sub-) category vehicle concerned.

4.6. The manufacturer shall supply the diameter(s) of the restricted section(s) and demonstrate to the approval authority and technical service that this restricted section is the most critical for the passage of gases, and that there is no other section which, if modified, could increase propulsion unit performance.

4.7. After mounting, the maximum thickness of a cylinder-head gasket shall not exceed 1,6 mm.;

(j) point 5.1. is replaced by the following:

‘5.1 Any variant or version under the same type of vehicle of subcategory L3e-A2 or of subcategory L4e-A2 complying with the conversion requirements set out in point 4 of Annex III, shall not be derived from a L3e-A3 or L4e-A3 type, variant or version with a maximum net engine power and/or maximum continuous rated power more than twice the values set out in the classification of subcategories L3e-A2 or L4e-A2 in Annex I to Regulation (EU) No 168/2013 (e.g. 70 kW to 35 kW or lower, 50 kW to 35 kW or lower).’;

(k) the following point 5.2.2. is inserted:

‘5.2.2. fuel feed and delivery system’;

(l) points 5.2.3. to 5.2.6. are replaced by the following:

‘5.2.3. air intake system including air filter(s) (modification or removal);

5.2.4. the drive train;

5.2.5. the control unit(s) that control(s) the propulsion unit performance of the powertrain;

5.2.6. removal of any component (mechanical, electrical, structural, etc.) which limits full engine load leading to any change in the propulsion unit performance approved in accordance with Annex II(A) to Regulation (EU) No 168/2013.’;

(m) point 5.2.7. is deleted;

(n) the following points 6 to 6.5.2. are added:

‘6. **Additional requirements for (sub)categories L1e, L2e, L3e-A1, L4e-A1 and L6e**

6.1. The parts, equipment and components listed below shall be durably and indelibly marked with code number(s) and symbols assigned for identification purposes either by the vehicle manufacturer or by the manufacturer of such (replacement) parts, equipment or components. Such marking may take the form of a label provided that it remains legible in normal use and cannot be detached without being destroyed.

6.2. The marking referred to in point 6.1. shall in principle be visible without dismantling the part in question or other parts of the vehicle. Where the bodywork or other parts of the vehicle obscure a marking, the vehicle manufacturer shall provide the competent authorities with indications for opening or dismantling the parts in question and the location of the marking.

6.3. The characters, figures or symbols used shall be at least 2,5 mm in height and be easily legible.

6.4. The parts, equipment and components referred to in point 6.1. are the following, for all (sub) categories:

6.4.1. any electrical/electronic device for the purpose of combustion engine or electric propulsion motor management (ECU ignition module, injectors, intake air temperature etc.),

6.4.2. carburettor or equivalent device,

6.4.3. catalytic converter(s) (only if not integrated in the silencer),

6.4.4. crankcase,

6.4.5. cylinder,

6.4.6. cylinder head,

- 6.4.7. exhaust pipe(s) (if separate from the silencer),
 - 6.4.8. inlet pipe (if cast separately from the carburettor or cylinder or crankcase),
 - 6.4.9. intake silencer (air filter),
 - 6.4.10. restricted section (sleeve or other),
 - 6.4.11. noise abatement device (silencer(s)),
 - 6.4.12. transmission driven part (rear chain wheel (sprocket) or pulley),
 - 6.4.13. transmission driving part (front chain wheel (sprocket) or pulley).
- 6.5. In addition, for categories L1e, L2e, and L6e, the following parts, equipment and components shall be marked in accordance with point 6.1.:
- 6.5.1. transmission CVT,
 - 6.5.2. transmission controller.;

(3) Annex III is amended as follows:

(a) points 4.2.5., 4.2.6. and 4.2.7. are replaced by the following:

- 4.2.5. All other type-approval requirements than the ones listed in point 4.2.2., 4.2.3 and 4.2.4. and which are set out in Annex II to Regulation (EU) No 168/2013 shall be regarded as common and equal between the (L3e/L4e)-A2 and (L3e/L4e)-A3 motorcycle configurations and shall therefore only be tested and reported once for both performance configurations. In addition, test reports related to systems, components, separate technical units, and parts or equipment of the vehicle fulfilling the same type-approval requirements on both configurations shall be accepted for the type-approval of any of these configurations.
- 4.2.6. One WVTA shall be issued for the category (L3e/L4e)-A2 configuration motorcycle having a unique type-approval number.
- 4.2.7. One WVTA shall be issued for the category (L3e/L4e)-A3 configuration motorcycle having a unique type-approval number. Both type-approval numbers referred to in point 4.2.6. and in this point shall be stamped into the statutory plate in accordance with Article 39 of Regulation (EU) No 168/2013 and with Annex V to Regulation (EU) No 901/2014. In order to facilitate the conversion of subcategory (L3e/L4e)-A2 into the (L3e/L4e)-A3 configuration motorcycle and vice versa, a template for a corresponding vehicle manufacturer's statement shall be attached to the information folder in accordance with Appendix 24 of part B of Annex I to Regulation (EU) No 901/2014. In addition, the dedicated entries for both the L3e-A2 and L3e-A3 configurations on the certificate of conformity shall be provided by the vehicle manufacturer in accordance with the template set out in Annex IV of Regulation (EU) No 901/2014.;

(b) points 4.2.10. and 4.2.11. are replaced by the following:

- 4.2.10. The Certificate of Conformity (CoC) shall be filled out in accordance with the requirements set out in point 1.7. of Annex IV to Regulation (EU) No 901/2014.
- 4.2.11. Only one vehicle identification number (VIN) of the (L3e/L4e)-A2 and A3 motorcycle configuration shall be assigned to motorcycles which can be converted from subcategories (L3e/L4e)-A2 to (L3e/L4e)-A3 or vice versa. The statutory plate fitted on the vehicle shall contain this VIN and shall bear a clear indication of the stationary noise levels in both configurations as well as the maximum net or maximum continuous rated power in the (L3e/L4e)-A2 configuration.;

(c) point 4.4.2 is deleted;

- (d) in point 6.1., the row relating to the requirement listed in Section (A2) of Annex II of Regulation (EU) No 168/2013 is replaced by the following:

'Section (A2) of Annex II	Self-testing	Testing procedures on maximum design vehicle speed	Only for subcategories L3e, L4e and L5e and does not include any other propulsion unit performance testing.;
---------------------------	--------------	--	--

- (4) Annex IV is amended as follows:

- (a) in point 4.1.1.3.1., 'tailpipe and CO₂ emissions' is replaced by 'tailpipe pollutant and CO₂ emissions';
- (b) in point 4.1.1.3.1.1., 'tailpipe and CO₂ emissions' is replaced by 'tailpipe pollutant and CO₂ emissions';
- (c) point 4.1.1.3.1.1.1.1 is replaced by the following:

'If the durability method set out in Article 23(3a) of Regulation (EU) No 168/2013 is applicable, the deterioration factors shall be calculated from the type I emission test results up to and including full mileage referred to in Annex VII(A) to Regulation (EU) No 168/2013 and in accordance with the linear calculation method referred to in point 4.1.1.3.1.1.1.2. resulting in slope and offset values per emission constituent. The CoP pollutant emission results shall be calculated with the formula:

Equation 4-1:

$$\text{if } x \leq b \text{ then } y = a \cdot x + b;$$

$$\text{if } x > b \text{ then } y = x$$

where:

a = slope value determined according to test type V according to Annex V(A) to Regulation (EU) No 168/2013;

b = offset value determined according to test type V according to Annex V(A) to Regulation (EU) No 168/2013;

x = pollutant emission (HC, CO, NO_x, NMHC and PM if applicable) test result per emission constituent of a degreened vehicle (maximum accumulated 100 km after the first start on the production line) in mg/km.

y = CoP emission result per pollutant emission constituent in mg/km. The average CoP results shall be lower than the pollutant emission limits set out in Annex VI(A) of Regulation (EU) No 168/2013.;

- (d) in point 4.1.1.3.1.1.1.3., 'tailpipe and CO₂ emissions' is replaced by 'tailpipe pollutant and CO₂ emissions';
- (e) in point 4.1.1.3.1.1.2.2., 'tailpipe and CO₂ emissions' is replaced by 'tailpipe pollutant and CO₂ emissions';
- (f) in point 4.1.1.3.1.1.2.3., 'tailpipe and CO₂ emissions' is replaced by 'tailpipe pollutant and CO₂ emissions';
- (g) in point 4.1.1.3.2.1., 'tailpipe and CO₂ emissions' is replaced by 'tailpipe pollutant and CO₂ emissions';
- (h) in point 4.1.1.3.2.3., 'the tailpipe emission limits' is replaced by 'tailpipe pollutant emission limits';

- (i) in point 4.1.1.3.2.4., 'Equation 4-2:' is replaced by 'Equation 4-3:';
 - (j) in point 4.1.1.3.3.1., 'tailpipe and CO₂ emissions' is replaced by 'tailpipe pollutant and CO₂ emissions';
 - (k) in point 4.1.1.3.3.3., 'tailpipe and CO₂ emissions' is replaced by 'tailpipe pollutant and CO₂ emissions';
 - (l) in point 4.1.1.3.3.4., 'Equations 4-3:' is replaced by 'Equations 4-4:';
 - (m) in point 4.1.1.3.3.6., 'Equations 4-4:' is replaced by 'Equations 4-5:';
 - (n) in point 4.1.1.4., in the second, third and fifth subparagraph, 'tailpipe and CO₂ emissions' is replaced by 'tailpipe pollutant and CO₂ emissions';
- (5) Annex VIII is amended as follows:

- (a) the following points 1.1.1., 1.1.1.1. and 1.1.1.2. are inserted:

'1.1.1. Vehicles of categories L1e, L3e and L4e shall meet the following general requirements:

1.1.1.1. Vehicles shall incorporate no pointed, sharp or protruding parts, pointing outwards, of such a shape, dimension, angle of direction and hardness that they increase the risk or seriousness of body lesions and lacerations suffered by any person struck or grazed by the vehicle in the event of an accident. Vehicles shall be designed so that parts and edges with which vulnerable road users such as pedestrians are likely to come into contact in the event of an accident comply with the requirements in points 1 to 1.3.8.

1.1.1.2. All contactable projections or edges which are made of or covered with material such as soft rubber or soft plastic having a hardness of less than 60 Shore (A) are considered to meet the requirements in points 1.3 to 1.3.8. The hardness measurement shall be carried out with the material fitted to the vehicle as intended.';

- (b) Points 1.1.2. to 1.1.3.2. are replaced by the following:

'1.1.2. Specific provisions for vehicles of categories L1e, L3e and L4e

1.1.2.1. Vehicles shall be assessed in accordance with the provisions in points 1.2 to 1.2.4.1.

1.1.2.2. In the case of vehicles fitted with a form of structure or panels intended to partially or fully enclose the rider, passenger or luggage or to cover certain vehicle components, the vehicle manufacturer may as an alternative choose to apply the relevant requirements of UNECE regulation No 26 (*) as prescribed for vehicle category M1, covering either specific external projections or the full external surface of the vehicle. In such cases, particular attention shall be given to the required radii whereas the amount of projection of handles, hinges, push-buttons and aerials do not need to be checked.

The relevant external projections assessed in conformity with this clause shall be clearly identified in the information document and any remaining external surface shall comply with the requirements of points 1. to 1.3.8.

(*) OJ L 215, 14.8.2010, p. 27.

1.1.3. Specific provisions for vehicles of category L4e

1.1.3.1. When the side-car is connected to the motorcycle, either permanently or in a detachable way, the space between the motorcycle and the side-car is exempted from assessment (see Figure 8-1).

Figure 8-1

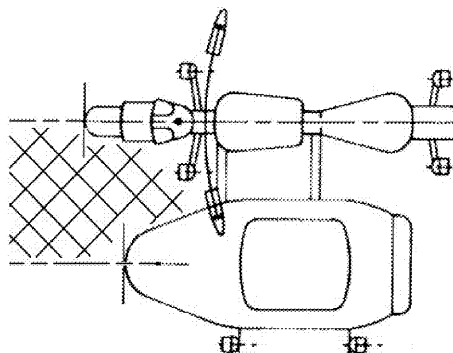
Top-down view of category L4e motorcycle with side-car

1.1.3.2. If the side-car can be detached from the motorcycle so that the motorcycle can be used without it, the motorcycle itself shall fulfil the requirements for solo motorcycles in points 1 to 1.3.8.;

(c) points 1.1.4. to 1.1.4.2. are deleted;

(d) points 1.2.3. to 1.2.3.2. are replaced by the following:

1.2.3. The testing device shall be moved from the front towards the rear of the vehicle, in a smooth motion, on both sides of it. If the testing device contacts the steering control or any parts mounted on it, it shall be rotated away into its fully locked position, during and after which the test continues. The testing device shall remain in contact with the vehicle or rider during the test (see Figure 8-2).

Figure 8-2

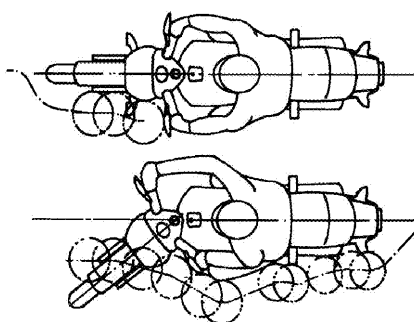
Test device movement zones

1.2.3.1. The front of the vehicle shall be the first point of contact and the testing device shall move sideways in an outward direction following the contour of the vehicle and the rider if applicable. The testing device shall also be allowed to move inward at a rate not exceeding the rate of rearward movement (i.e. at an angle of 45° in relation to the longitudinal median plane of the vehicle).

1.2.3.2. The hands and feet of the rider shall be pushed away by the testing device if it comes into direct contact with them and any relevant supports (e.g. foot supports) shall be allowed to freely rotate, fold, bend or flex as a result of contact with the testing device and assessed in all resulting intermediate positions.;

(e) point 1.3.3.2. is replaced by the following:

'1.3.3.2. If a radius is applied to the upper edge, it shall not be larger than 0,70 times the thickness of the windscreen or fairing, as measured at the upper edge.');

(f) point 1.3.5.2. is replaced by the following:

'1.3.5.2. The radius as applied to the leading edge of the front mudguard shall not be larger than 0,70 times the thickness of the mudguard, as measured at the leading edge (e.g. in case of a round bead on the edge of sheet metal, the diameter of the bead is taken as the relevant thickness).';

(g) in point 2.1.2.1.1., the following second subparagraph is inserted:

'In accordance with the first subparagraph, some portions of the kinds of vehicle concerned may be assessed with the external projections testing device (see Appendix 1) and the remaining portions shall be assessed with the sphere measuring 100 mm in diameter (see UNECE Regulation No 26). In such cases, particular attention shall be given to the required radii whereas the amount of projection of handles, hinges, push-buttons and aerials does not need to be checked.';

(6) Annex IX is amended as follows:

(a) point 2.2.1. is replaced by the following:

'2.2.1. The tank shall be subjected to a hydraulic internal pressure test which shall be carried out on an isolated unit complete with all its accessories. The tank shall be completely filled with a non-flammable liquid having a density and a viscosity close to those of the fuel normally used, or with water. After all communication with the outside has been cut off, the pressure shall be gradually increased, through the pipe connection through which fuel is fed to the engine, to the internal pressure specified in point 1.2.9. and this pressure shall be maintained for at least 60 seconds.';

(b) point 3.2.1. is replaced by the following:

'3.2.1. The permeability test as part of type IV testing referred to in Part A of Annex V to Regulation (EU) No 168/2013 without having to take into account any diffusion measurements for the purpose of the test in accordance with this Annex, shall be carried out on a sufficient number of tanks for the purpose of testing in accordance with points 3.3 to 3.7.5.1. The total duration of the preconditioning procedure shall be composed of a pre-storage period of at least four weeks followed by a subsequent eight-week stabilised condition storage period.';

(c) point 3.3.1. is replaced by the following:

'3.3.1. The fuel tank is filled up to its total rated capacity with a mixture of 50 % water and 50 % ethylene glycol or with any other coolant which does not deteriorate the fuel tank material, the cryoscopic point of which is lower than $243 \pm 2 \text{ K}$ ($-30 \pm 2 \text{ }^\circ\text{C}$).

The temperature of the substances contained in the fuel tank during the test shall be $253 \pm 2 \text{ K}$ ($-20 \pm 2 \text{ }^\circ\text{C}$). The tank is cooled down to a corresponding ambient temperature. The fuel tank may also be filled with a suitably refrigerated liquid provided that it is left at the test temperature for at least an hour.

A pendulum is used for the test. Its impact head shall have the form of an equilateral triangular pyramid with a radius of curvature of 3,0 mm at its peak and edges. The freely moving mass of the pendulum shall have a mass of $15 \text{ kg} \pm 0,5 \text{ kg}$ and the exerted pendulum's energy shall not be less than 30,0 J for each impact on the fuel tank.

The technical service may select any number of points on the fuel tank to be tested and these points shall reflect locations which are considered at risk as a result of the fitting of the tank and its position on the vehicle. Non-metal shielding shall be disregarded and frame tubing or chassis sections may be taken into account for the assessment of risk.

More than one fuel tank may be used for the completion of all impacts, provided that all fuel tanks to be used have undergone the permeability test.

There shall be no leakage of liquid following a single impact at any one of the tested points.;

(d) point 3.4.1. is replaced by the following:

'3.4.1. The fuel tank shall be filled up to its total rated capacity, the test liquid used being water at 326 ± 2 K (53 ± 2 °C). The tank shall then be subjected to an internal pressure equal to twice the relative service pressure (design pressure) or an overpressure of 30 kPa, whichever is higher. The tank shall remain closed and pressurised for a period of not less than five hours at an ambient temperature of 326 ± 2 K (53 ± 2 °C).

The fuel tank shall not show signs of leakage and any temporary or permanent deformation which may arise shall not render it unusable. Account shall be taken of specific fitting conditions if the deformation of the tank is to be assessed.;

(e) point 3.5.1. is replaced by the following:

'3.5.1. Six tensile test-pieces of approximately the same thickness are taken from flat or nearly flat faces of the completely new fuel tank. Their tensile strength and elastic limits are established at 296 ± 2 K (23 ± 2 °C) at an elongation rate of 50 mm/min. The obtained values shall then be compared with the tensile strength and elasticity values obtained from similar tests carried out using a fuel tank which has undergone the permeability test. The material shall be considered to be acceptable if the tensile strength differs by no more than 25 %.;

(f) point 3.6.1. is replaced by the following:

'3.6.1. The fuel tank shall be fitted to a representative part of the vehicle and filled to 50 % of its total rated capacity with water at 293 ± 2 K (20 ± 2 °C). The test setup including the fuel tank shall then be placed in an ambient temperature of 343 ± 2 K (70 ± 2 °C) for 60 minutes, after which the fuel tank shall not display any permanent deformation or leaks and shall be in fully usable condition.;

(g) point 3.7.4.3. is replaced by the following:

'3.7.4.3. The average combustion time (ACT) and average combustion length (ACL) shall be calculated if no sample out of ten or no more than one out of 20 has burnt up to the 100 mm mark.

Equation 9-1:

$$\text{ACT (s)} = \sum_{i=1}^n \cdot ((t_i - 30) / (n))$$

(note: n = number of samples)

The result is rounded up or down to the nearest five-second increment. However, an ACT of 0 seconds shall not be used. (i.e. if the combustion lasts between less than 2 seconds and 7 seconds, the ACT is 5 seconds; if the combustion lasts between 8 and 12 seconds, the ACT is 10 seconds; if the combustion lasts between 13 and 17 seconds, the ACT is 15 seconds, etc.).

Equation 9-2:

$$\text{ACL (mm)} = \sum_{i=1}^n \cdot ((100 - \text{unburnt length}_i) / (n))$$

(note: n = number of samples)

The result is expressed in relation to the nearest 5 mm increment (i.e. 'less than 5 mm' shall be stated if the combustion length is less than 2 mm and thus in no case can an ACL of 0 mm be given).

Where a single sample out of 20 burns up to or beyond the 100 mm mark, the combustion length (i.e. the value of (100 – unburnt length,) for that sample) shall be taken as 100 mm.

Equation 9-3:

$$n_{\text{average_combustion_speed}} = \frac{ACL}{ACT} \text{ in } \frac{mm}{s}$$

This value shall be compared against the requirement as laid down in points 3.7.5. to 3.7.5.1.;

(7) In Annex XI, in Appendix 1, point 1.6. is replaced by the following:

‘1.6. Ground clearance

1.6.1. For the purpose of measuring the ground clearance of an L-category vehicle type, the test vehicle shall be loaded to the actual mass.

1.6.2. As an exception to point 1.6.1., for the purpose of measuring the ground clearance of a subcategory L3e-AxE vehicle type (x = 1, 2 or 3, two-wheel Enduro motorcycle) or a subcategory L3e- AxT vehicle type (x = 1, 2 or 3, two-wheel Trial motorcycle), the test Enduro or Trial motorcycle shall be loaded to its mass in running order.

1.6.3. Any manually or automatically adjustable suspension system fitted to the vehicle, possibly resulting in a variable ground clearance, shall be put to its minimum setting allowing the minimum distance between vehicle and ground plane.

1.6.4. The shortest distance between the ground plane and the lowest fixed point of the vehicle shall be measured between the axles and under the axle(s), if applicable in accordance with Appendix 1 to Annex II to Directive of the European Parliament and of the Council 2007/46/EC (*). That minimum measured distance shall be regarded as the ground clearance of the vehicle.

(*) Directive 2007/46/EC of the European Parliament and of the Council of 5 September 2007 establishing a framework for the approval of motor vehicles and their trailers, and of systems, components and separate technical units intended for such vehicles (Framework Directive) (OJ L 263, 9.10.2007, p. 1).;

(8) Annex XII is amended as follows:

(a) in point 2.2.2., Table 12-1 is replaced by the following:

‘Table 12-1

OBD stage II functions and associated requirements in the points of this Annex and Appendix 1

Topic	Point in this Annex and in Appendix 1
General disable criterion for degradation type of diagnostics in OBD stage II	3.2.1.1.
Catalytic converter monitoring	3.3.2.1.; 3.3.3.1.
EGR efficiency/flow monitoring	3.3.3.4.
In-use performance monitoring	2nd sub point of point 3.3. of Appendix 1, point 4 of Appendix 1
General OBD stage II requirement	3.3. of Appendix 1

Topic	Point in this Annex and in Appendix 1
Misfire detection	3.2.2.; 3.3.2.2.; 3.5.3.; 3.6.2.; 3.7.1.; 3.1.2. of Appendix 1
NOx after-treatment system monitoring	3.3.3.5.; 3.3.3.6.
Oxygen sensor deterioration monitoring	3.3.2.3.
Particulate filter monitoring	3.3.3.2.
Particulate matter (PM) emission monitoring	3.3.2.5.'

(b) points 3.2.2.1. and 3.2.2.1. are replaced by the following:

'3.2.2.1. Manufacturers may adopt higher misfire percentage malfunction criteria than those declared to the authority, under specific engine speed and load conditions where it can be demonstrated to the authority that the detection of lower levels of misfire would be unreliable. In terms of OBD monitoring, it is that percentage of misfires out of a total number of firing events (as declared by the manufacturer) that would result in emissions exceeding the OBD thresholds set out in Section (B) of Annex VI to Regulation (EU) No 168/2013, or that percentage that could lead to an exhaust catalyst, or catalysts, overheating, causing irreversible damage.

3.2.2.2. When a manufacturer can demonstrate to the authority that the detection of higher levels of misfire percentages is still not feasible, or that misfire cannot be distinguished from other effects (e.g. rough roads, transmission shifts, after engine starting, etc.), the misfire monitoring system may be disabled when such conditions exist.;

(c) in point 3.6., the last sentence is replaced by the following:

'A fault code shall also be stored in the cases referred to in points 3.3.5. and 3.3.6.;

(d) point 3.6.1. is replaced by the following:

'The distance travelled by the vehicle while the MI is activated shall be available at any moment through the serial port on the standardised diagnostic connector. By means of derogation for vehicles equipped with a mechanically operating odometer that does not allow input to the electronic control unit including such vehicles equipped with a CVT that does not allow for an accurate input to the electronic control unit, "distance travelled" may be replaced with "engine operation time" and shall be made available at any moment through the serial port on the standardised diagnostic connector.'

(e) points 4.3. and 4.4. are replaced by the following:

'4.3. In the identified order of deficiencies, those relating to points 3.3.2.1, 3.3.2.2 and 3.3.2.3 for positive-ignition engines and points 3.3.3.1, 3.3.3.2 and 3.3.3.3 for compression-ignition engines shall be identified first.

4.4. Prior to, or at the time of, type-approval, no deficiency shall be granted with regard to the requirements set out in point 3. of Appendix 1, except the requirements laid down in point 3.11. of Appendix 1.;

(f) the following point 4.7. is added:

'The vehicle family criteria laid down in table 11-1 in point 3.1. of Annex XI to Regulation (EU) No 134/2014 with regard to test type VIII shall also be applicable for the functional on-board diagnostic requirements set out in this Annex.;

(g) in Appendix 1, point 3.13. is replaced by the following:

'Until a standardised connection interface for L-category vehicles has been adopted and published at ISO or CEN level and the reference of that technical standard is included in this Regulation, an alternative connection interface may be installed at the request of the vehicle manufacturer. Where such an alternative connection interface is installed, the vehicle manufacturer shall make available to test equipment manufacturers the details of the vehicle connector pin configuration free of charge. The vehicle manufacturer shall provide an adapter enabling connection to a generic scan tool. Such an adapter shall be of suitable quality for professional workshop use. It shall be provided upon request to all independent operators in a non-discriminating manner. Manufacturers may charge a reasonable and proportionate price for this adapter, taking into account the additional costs caused for the customer by this choice of the manufacturer. The connection interface and the adapter may not include any specific design elements which would require validation or certification before use, or which would restrict the exchange of vehicle data when using a generic scan tool.'

(h) in Appendix 2, in point 2.1., in Table Ap2-1, 'Device operational/Device present' is replaced by 'Device not operational/Device not present';

(i) in Appendix 2, point 2.6.2. is replaced by the following:

'2.6.2. monitoring of some of the items listed in Table Ap2-1 is physically not possible and a deficiency has been granted for this incomplete monitor. The comprehensive, technical justification why such an OBD monitor cannot run shall be added to the information folder.'

(9) In Annex XIII the following point 1.4. is added:

'1.4. The maximum pressures mentioned in points 1.2.1., 1.2.2., 1.2.3. and 1.3.1. may be exceeded during testing upon agreement with the vehicle manufacturer.'

(10) In Annex XIV, point 1.5.1.5.1. is replaced by the following:

'1.5.1.5.1. The plate shall be visible in the whole space within the following four planes:

- the two vertical planes touching the two lateral edges of the plate and forming an angle measured outwards to the left and to the right of the plate of 30° in relation to the longitudinal plane, parallel to the longitudinal median plane of the vehicle, passing through the centre of the plate;
- the plane touching the upper edge of the plate and forming an angle measured upwards of 15° to the horizontal;
- the horizontal plane through the lower edge of the plate.'

(11) in Annex XVI, the following point 2.3.5.1. is inserted:

'2.3.5.1. However, by way of derogation from points 1.2.1. and 2.3.5. a prop stand fitted to a vehicle of category L3e-A1E, L3e-A2E, L3e-A3E, L3e-A1T, L3e-A2T or L3e-A3T may swing back automatically when the prop stand is not being held or supported by a person.'

—

ANNEX III

Amendments to Delegated Regulation (EU) No 134/2014

The Annexes to Delegated Regulation (EU) No 134/2014 are amended as follows:

(1) Annex II is amended as follows:

(a) points 4.5.5.2.1.1. and 4.5.5.2.1.2. are replaced by the following:

‘4.5.5.2.1.1. Step 1 — Calculation of shift speeds

Upshift speeds ($v_{1 \rightarrow 2}$ and $v_{i \rightarrow i+1}$) in km/h during acceleration phases shall be calculated using the following formulae:

Equation 2-3:

$$v_{1 \rightarrow 2} = \left[\left(0,5753 \times e^{\left(-1,9 \times \frac{P_n}{m_k} \right)} - 0,1 \right) \times (s - n_{idle}) + n_{idle} \right] \times \frac{1}{ndv_1}$$

Equation 2-4:

$$v_{i \rightarrow i-1} = \left[\left(0,5753 \times e^{\left(-1,9 \times \frac{P_n}{m_k} \right)} \right) \times (s - n_{idle}) + n_{idle} \right] \times \frac{1}{ndv_{i-2}}, \quad i = 2 \text{ to } ng - 1$$

where:

‘i’ is the gear number (≥ 2)

‘ng’ is the total number of forward gears

‘ P_n ’ is the rated power in kW

‘ m_k ’ is the reference mass in kg

‘ n_{idle} ’ is the idling speed in min^{-1}

‘s’ is the rated engine speed in min^{-1}

‘ ndv_i ’ is the ratio between engine speed in min^{-1} and vehicle speed in km/h in gear ‘i’

4.5.5.2.1.2. Downshift speeds ($v_{i \rightarrow i-1}$) in km/h during cruise or deceleration phases in gears 4 (4th gear) to ng shall be calculated using the following formula:

Equation 2-5:

$$v_{i \rightarrow i-1} = \left[\left(0,5753 \times e^{\left(-1,9 \times \frac{P_n}{m_k} \right)} \right) \times (s - n_{idle}) + n_{idle} \right] \times \frac{1}{ndv_{i-2}}, \quad i = 4 \text{ to } ng$$

where:

i is the gear number (≥ 4)

ng is the total number of forward gears

P_n is the rated power in kW

m_k is the reference mass in kg

n_{idle} is the idling speed in min^{-1}

s is the rated engine speed in min^{-1}

ndv_{i-2} is the ratio between engine speed in min^{-1} and vehicle speed in km/h in gear $i - 2$

The downshift speed from gear 3 to gear 2 ($v_{3 \rightarrow 2}$) shall be calculated using the following equation:

Equation 2-6:

$$v_{3 \rightarrow 2} = \left[(0,5753 \times e^{(-1,9 \times \frac{P_n}{m_k})} - 0,1) \times (s - n_{idle}) + n_{idle} \right] \times \frac{1}{ndv_1}$$

where:

P_n is the rated power in kW

m_k is the reference mass in kg

n_{idle} is the idling speed in min^{-1}

s is the rated engine speed in min^{-1}

ndv_1 is the ratio between engine speed in min^{-1} and vehicle speed in km/h in gear 1

The downshift speed from gear 2 to gear 1 ($v_{2 \rightarrow 1}$) shall be calculated using the following equation:

Equation 2-7:

$$v_{2 \rightarrow 1} = [0,03 \times (s - n_{idle}) + n_{idle}] \times \frac{1}{ndv_2}$$

where:

ndv_2 is the ratio between engine speed in min^{-1} and vehicle speed in km/h in gear 2

Since the cruise phases are defined by the phase indicator, slight speed increases could occur and it may be appropriate to apply an upshift. The upshift speeds ($v_{1 \rightarrow 2}$, $v_{2 \rightarrow 3}$ and $v_{i \rightarrow i+1}$) in km/h during cruise phases shall be calculated using the following equations:

Equation 2-7a:

$$v_{1 \rightarrow 2} = [0,03 \times (s - n_{idle}) + n_{idle}] \times \frac{1}{ndv_2}$$

Equation 2-8:

$$v_{2 \rightarrow 3} = \left[(0,5753 \times e^{(-1,9 \times \frac{P_n}{m_k})} - 0,1) \times (s - n_{idle}) + n_{idle} \right] \times \frac{1}{ndv_1}$$

Equation 2-9:

$$v_{i \rightarrow i+1} = \left[(0,5753 \times e^{(-1,9 \times \frac{P_n}{m_k})} - 0,1) \times (s - n_{idle}) + n_{idle} \right] \times \frac{1}{ndv_{i-1}}, i = 3 \text{ to } ng'$$

(b) points 6.1.1.4.2. to 6.1.1.4.7. are replaced by the following:

'6.1.1.4.2. Hydrocarbons (HC)

The mass of unburned hydrocarbons emitted by the exhaust of the vehicle during the test shall be calculated using the following formula:

Equation 2-33:

$$HC_m = \frac{1}{S} \cdot V \cdot d_{HC} \cdot \frac{HC_C}{10^6}$$

where:

HC_m is the mass of hydrocarbons emitted during the test part, in mg/km;

S is the distance defined in point 6.1.1.3.;

V is the total volume, defined in point 6.1.1.4.1.;

d_{HC} is the density of the hydrocarbons at reference temperature and pressure (273,2 K and 101,3 kPa);

$$\begin{aligned}
 d_{HC} &= 0,631 \cdot 10^3 \text{ mg/m}^3 \text{ for petrol (E5) (C}_1\text{H}_{1,89}\text{O}_{0,016}\text{);} \\
 &= 932 \cdot 10^3 \text{ mg/m}^3 \text{ for ethanol (E85) (C}_1\text{H}_{2,74}\text{O}_{0,385}\text{);} \\
 &= 622 \cdot 10^3 \text{ mg/m}^3 \text{ for diesel (B5) (C}_1\text{H}_{1,86}\text{O}_{0,005}\text{);} \\
 &= 649 \cdot 10^3 \text{ mg/m}^3 \text{ for LPG (C}_1\text{H}_{2,525}\text{);} \\
 &= 714 \cdot 10^3 \text{ mg/m}^3 \text{ for NG/biogas (C}_1\text{H}_4\text{);} \\
 &= \frac{9,104 \cdot A + 136}{1\,524,152 - 0,583 \cdot A} \cdot 10^6 \text{ mg/m}^3 \text{ for H}_2\text{NG (with A = NG/biomethane quantity within the} \\
 &\quad \text{H}_2\text{NG mixture in (volume \%)).}
 \end{aligned}$$

HC_c is the concentration of diluted gases, expressed in parts per million (ppm) of carbon equivalent (e.g. the concentration in propane multiplied by three), corrected to take account of the dilution air by the following equation:

Equation 2-34:

where:

HC_c is the concentration of hydrocarbons expressed in parts per million (ppm) of carbon equivalent, in the sample of diluted gases collected in bag(s) A;

HC_d is the concentration of hydrocarbons expressed in parts per million (ppm) of carbon equivalent, in the sample of dilution air collected in bag(s) B;

DiF is the coefficient defined in point 6.1.1.4.7.

The non-methane hydrocarbon (NMHC) concentration is calculated as follows:

Equation 2-35:

$$C_{NMHC} = C_{THC} - (Rf_{CH_4} \cdot C_{CH_4})$$

where:

C_{NMHC} = corrected concentration of NMHC in the diluted exhaust gas, expressed in ppm carbon equivalent;

C_{THC} = concentration of total hydrocarbons (THC) in the diluted exhaust gas, expressed in ppm carbon equivalent and corrected by the amount of THC contained in the dilution air;

C_{CH_4} = concentration of methane (CH_4) in the diluted exhaust gas, expressed in ppm carbon equivalent and corrected by the amount of CH_4 contained in the dilution air;

Rf_{CH_4} is the FID response factor to methane as defined in point 5.2.3.4.1.

6.1.1.4.3. Carbon monoxide (CO)

The mass of carbon monoxide emitted by the exhaust of the vehicle during the test shall be calculated using the following formula:

Equation 2-36:

$$CO_m = \frac{1}{S} \cdot V \cdot d_{CO} \cdot \frac{CO_c}{10^6}$$

where:

CO_m is the mass of carbon monoxide emitted during the test part, in mg/km;

S is the distance defined in point 6.1.1.3.;

V is the total volume defined in point 6.1.1.4.1.;

d_{CO} is the density of the carbon monoxide, $d_{CO} = 1,25 \cdot 10^6$ mg/m³ at reference temperature and pressure (273,2 K and 101,3 kPa);

CO_c is the concentration of diluted gases, expressed in parts per million (ppm) of carbon monoxide, corrected to take account of the dilution air by the following equation:

Equation 2-37:

$$CO_c = CO_e - CO_d \cdot \left(1 - \frac{1}{DiF}\right)$$

where:

CO_e is the concentration of carbon monoxide expressed in parts per million (ppm), in the sample of diluted gases collected in bag(s) A;

CO_d is the concentration of carbon monoxide expressed in parts per million (ppm), in the sample of dilution air collected in bag(s) B;

DiF is the coefficient defined in point 6.1.1.4.7.

6.1.1.4.4. Nitrogen oxides (NO_x)

The mass of nitrogen oxides emitted by the exhaust of the vehicle during the test shall be calculated using the following formula:

Equation 2-38:

$$NO_{xm} = \frac{1}{S} \cdot V \cdot d_{NO_2} \cdot \frac{NO_{xe} \cdot K_h}{10^6}$$

where:

NO_{xm} is the mass of nitrogen oxides emitted during the test part, in mg/km;

S is the distance defined in point 6.1.1.3.;

V is the total volume defined in point 6.1.1.4.1.;

d_{NO_2} is the density of the nitrogen oxides in the exhaust gases, assuming that they will be in the form of nitric oxide, $d_{NO_2} = 2,05 \cdot 10^6$ mg/m³ at reference temperature and pressure (273,2 K and 101,3 kPa);

NO_{xc} is the concentration of diluted gases, expressed in parts per million (ppm), corrected to take account of the dilution air by the following equation:

Equation 2-39:

$$NO_{xc} = NO_{xe} - NO_{xd} \cdot \left(1 - \frac{1}{DiF}\right)$$

where:

NO_{xe} is the concentration of nitrogen oxides expressed in parts per million (ppm) of nitrogen oxides, in the sample of diluted gases collected in bag(s) A;

NO_{xd} is the concentration of nitrogen oxides expressed in parts per million (ppm) of nitrogen oxides, in the sample of dilution air collected in bag(s) B;

DiF is the coefficient defined in point 6.1.1.4.7.

K_h is the humidity correction factor, calculated using the following formula:

Equation 2-40:

$$K_h = \frac{1}{1 - 0,0329 \cdot (H - 10,7)}$$

where:

H is the absolute humidity in g of water per kg of dry air:

Equation 2-41:

$$H = \frac{6,2111 \cdot U \cdot P_d}{P_a - P_d \cdot \frac{U}{100}}$$

where:

U is the humidity as a percentage;

P_d is the saturated pressure of water at the test temperature, in kPa;

P_a is the atmospheric pressure in kPa.

6.1.1.4.5. Particulate matter mass

Particulate emission M_p (mg/km) is calculated by means of the following equation:

Equation 2-42:

$$M_p = \frac{(V_{mix} + V_{ep}) \cdot P_e}{V_{ep} \cdot d}$$

where exhaust gases are vented outside the tunnel;

Equation 2-43:

$$M_p = \frac{V_{mix} \cdot P_e}{V_{ep} \cdot S}$$

where exhaust gases are returned to the tunnel;

where:

V_{mix} = volume V of diluted exhaust gases under standard conditions;

V_{ep} = volume of exhaust gas flowing through particulate filter under standard conditions;

P_e = particulate mass collected by filter(s) in mg;

S = is the distance defined in point 6.1.1.3.;

M_p = particulate emission in mg/km.

Where correction for the particulate background level from the dilution system has been used, this shall be determined in accordance with point 5.2.1.5. In this case, the particulate mass (mg/km) shall be calculated as follows:

Equation 2-44:

$$M_p = \left[\frac{P_e}{V_{\text{ep}}} - \left(\frac{P_a}{V_{\text{ap}}} \cdot \left(1 - \frac{1}{\text{DiF}} \right) \right) \right] \cdot \frac{(V_{\text{mix}} + V_{\text{ep}})}{d}$$

where exhaust gases are vented outside the tunnel;

Equation 2-45:

$$M_p = \left[\frac{P_e}{V_{\text{ep}}} - \left(\frac{P_a}{V_{\text{ap}}} \cdot \left(1 - \frac{1}{\text{DiF}} \right) \right) \right] \cdot \frac{V_{\text{mix}}}{d}$$

where exhaust gases are returned to the tunnel;

where:

V_{ap} = volume of tunnel air flowing through the background particulate filter under standard conditions;

P_a = particulate mass collected by background filter;

DiF is the coefficient defined in point 6.1.1.4.7.

Where application of a background correction results in a negative particulate mass (in mg/km), the result shall be considered to be zero mg/km particulate mass.

6.1.1.4.6. Carbon dioxide (CO₂)

The mass of carbon dioxide emitted by the exhaust of the vehicle during the test shall be calculated using the following formula:

Equation 2-46:

$$\text{CO}_{2m} = \frac{1}{S} \cdot V \cdot d_{\text{CO}_2} \cdot \frac{\text{CO}_{2c}}{10^2}$$

where:

CO_{2m} is the mass of carbon dioxide emitted during the test part, in g/km;

S is the distance defined in point 6.1.1.3.;

V is the total volume defined in point 6.1.1.4.1.;

d_{CO_2} is the density of the carbon monoxide, $d_{\text{CO}_2} = 1,964 \cdot 10^3 \text{ g/m}^3$ at reference temperature and pressure (273,2 K and 101,3 kPa);

CO_{2c} is the concentration of diluted gases, expressed as a percentage of carbon dioxide equivalent, corrected to take account of the dilution air by the following equation:

Equation 2-47:

$$\text{CO}_{2c} = \text{CO}_{2e} - \text{CO}_{2d} \times \left(1 - \frac{1}{\text{DiF}}\right)$$

where:

CO_{2e} is the concentration of carbon dioxide expressed as a percentage of the sample of diluted gases collected in bag(s) A;

CO_{2d} is the concentration of carbon dioxide expressed as a percentage of the sample of dilution air collected in bag(s) B;

DiF is the coefficient defined in point 6.1.1.4.7.

6.1.1.4.7. Dilution factor (DiF)

The dilution factor is calculated as follows:

For each reference fuel, except hydrogen:

Equation 2-48:

$$\text{DiF} = \frac{X}{C_{\text{CO}_2} + (C_{\text{HC}} + C_{\text{CO}}) \cdot 10^{-4}}$$

For a fuel of composition $\text{C}_x\text{H}_y\text{O}_z$, the general formula is:

Equation 2-49:

$$X = 100 \cdot \frac{x}{x + \frac{y}{2} + 3,76 \cdot \left(x + \frac{y}{4} - \frac{z}{2}\right)}$$

For H_2NG , the formula is:

Equation 2-50:

$$X = \frac{65,4 \cdot A}{4,922 \cdot A + 195,84}$$

For hydrogen, the dilution factor is calculated as follows:

Equation 2-51:

$$\text{DiF} = \frac{X}{C_{\text{H}_2\text{O}} - C_{\text{H}_2\text{O-DA}} + C_{\text{H}_2} \cdot 10^{-4}}$$

For the reference fuels contained in Appendix x, the values of 'X' are as follows:

Table 1-8

Factor 'X' in formulae to calculate DiF

Fuel	X
Petrol (E5)	13,4
Diesel (B5)	13,5
LPG	11,9
NG/biomethane	9,5
Ethanol (E85)	12,5
Hydrogen	35,03

In these equations:

C_{CO_2} = concentration of CO_2 in the diluted exhaust gas contained in the sampling bag, expressed in percent by volume,

C_{HC} = concentration of HC in the diluted exhaust gas contained in the sampling bag, expressed in ppm carbon equivalent,

C_{CO} = concentration of CO in the diluted exhaust gas contained in the sampling bag, expressed in ppm,

C_{H_2O} = concentration of H_2O in the diluted exhaust gas contained in the sampling bag, expressed in percent by volume,

C_{H_2O-DA} = concentration of H_2O in the air used for dilution, expressed in percent by volume,

C_{H_2} = concentration of hydrogen in the diluted exhaust gas contained in the sampling bag, expressed in ppm,

A = quantity of NG/biomethane in the H_2NG mixture, expressed in percent by volume.;

(c) in point 6.1.1.5.1.1., 'Weighting of results from UNECE regulation No 40 and regulation No 47 test cycles' is replaced by 'Weighting of results from ECE R40 and ECE R47 test cycles';

(d) in Appendix 1, in Table Ap 1-1, the row relating to symbol 'DF' is replaced by the following:

'DiF	Dilution factor	—'
------	-----------------	----

(e) in Appendix 2, in point 1.1., the second sentence is replaced by the following:

'The fuel specifications in this Appendix are consistent with the reference fuel specifications in Annex 10 to UNECE regulation No 83 Revision 4 (*).

(*) OJ L 42, 12.2.2014, p. 1.;

(f) In Appendix 11, point 3.2.1.3. is replaced by the following:

'3.2.1.3. The operating mode switch shall be positioned in accordance with the table Ap11-2.

Table Ap11-2

Look-up table to determine Condition A or B depending on different hybrid vehicle concepts and on the hybrid mode selection switch position

	Hybrid-modes →	— Pure electric — Hybrid	— Pure fuel-consuming — Hybrid	— Pure electric — Pure fuel-consuming — Hybrid	— Hybrid mode n ⁽¹⁾ — Hybrid mode m ⁽¹⁾
Battery state of charge		Switch in position	Switch in position	Switch in position	Switch in position
Condition A Fully charged		Hybrid	Hybrid	Hybrid	Most electric hybrid mode ⁽²⁾
Condition B Min. state of charge		Hybrid	Fuel-consuming	Fuel-consuming	Most fuel-consuming mode ⁽³⁾

⁽¹⁾ For instance: sport, economic, urban, extra-urban position, etc.

⁽²⁾ Most electric hybrid mode: the hybrid mode which can be proven to have the highest electricity consumption of all selectable hybrid modes when tested in accordance with condition A of point 4 of Annex 10 to UNECE Regulation No 101, to be established based on information provided by the manufacturer and in agreement with the technical service.

⁽³⁾ Most fuel-consuming mode: the hybrid mode which can be proven to have the highest fuel consumption of all selectable hybrid modes when tested in accordance with condition B of point 4 of Annex 10 to UNECE regulation No 101, to be established based on information provided by the manufacturer and in agreement with the technical service.'

(2) Annex V is amended as follows:

(a) Appendix 2 is amended as follows:

(i) in point 1.1., the following sentence is added:

'In order to satisfy the evaporative emission test requirements set out in Regulation (EU) No 168/2013, only L-vehicle (sub-)categories L3e, L4e, L5e-A, L6e-A and L7e-A shall be tested.';

(ii) in point 4.4., '301,2 ± 2 K (28 ± 5 °C)' is replaced by '301,2 ± 5 K (28 ± 5 °C)';

(b) Appendix 3 is amended as follows:

(i) in point 4.4.1., the first sentence is replaced by the following:

'The fuel tank heating system shall consist of at least two separate heat sources with two temperature controllers.';

(ii) in point 4.7.2., 'Appendix 1' is replaced by 'Appendix 4';

(iii) point 5.2.3. is replaced by the following:

'5.2.3. The vehicle is parked in the test area for the minimum period stated in Table Ap3-1.

Table Ap3-1

SHED test — minimum and maximum soak periods

Engine capacity	Minimum (hours)	Maximum (hours)
< 170 cm ³	6	36
170 cm ³ ≤ engine capacity < 280 cm ³	8	36
≥ 280 cm ³	12	36'

(iv) points 5.3.1.5. and 5.3.1.6. are replaced by the following:

5.3.1.5. The fuel and vapour may be artificially heated to the starting temperatures of 288,7 K (15,5 °C) and 294,2 K (21,0 °C) ± 1 K respectively. An initial vapour temperature up to 5 °C above 21,0 °C may be used. For this condition, the vapour shall not be heated at the beginning of the diurnal test. When the fuel temperature has been raised to 5,5 °C below the vapour temperature by following the T_f function, the remainder of the vapour heating profile shall be followed.

5.3.1.6. As soon as the fuel temperature reaches 14,0 °C:

- (1) Install the fuel filler cap(s);
- (2) Turn off the purge blowers, if not already off at that time;
- (3) Close and seal enclosure doors.

As soon as the fuel reaches a temperature of 15,5 °C ± 1 °C the test procedure shall continue as follows:

- (a) the hydrocarbon concentration, barometric pressure and the temperature shall be measured to give the initial readings C_{HC} , i , p_i and T_i for the tank heat build test;
- (b) a linear heat build of 13,8 °C or 20 °C ± 0,5 °C over a period of 60 ± 2 minutes shall begin. The temperature of the fuel and fuel vapour during the heating shall conform to the function below to within ± 1,7 °C, or the closest possible function as described in 4.4:

For exposed type of fuel storage tanks:

Equations B.3.3-1

$$T_f = 0,3333 \cdot t + 15,5 \text{ °C}$$

$$T_v = 0,3333 \cdot t + 21,0 \text{ °C}$$

For non-exposed type of fuel storage tanks:

Equations B.3.3-2

$$T_f = 0,2222 \cdot t + 15,5 \text{ °C}$$

$$T_v = 0,2222 \cdot t + 21,0 \text{ °C}$$

where:

T_f = required temperature of fuel (°C);

T_v = required temperature of vapour (°C);

t = time from start of the tank heat build in minutes;'

(c) Appendix 3.2 is amended as follows:

(i) point 2 is replaced by the following:

'2. Carbon canister ageing

Figure Ap3.2-1

Carbon canister gas flow diagram and ports

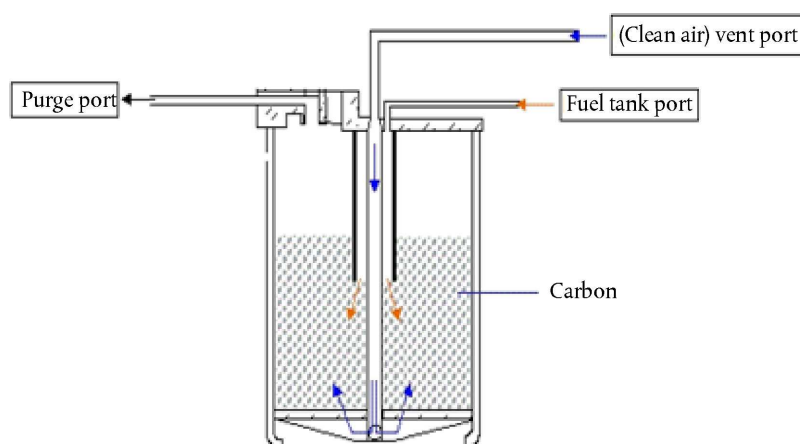

A carbon canister representative of the propulsion family of the vehicle as set out in Annex XI shall be selected as test canister and shall be marked in agreement with the approval authority and the technical service;'

(ii) point 3.1 is replaced by the following:

'3.1 The durability test shall actuate control valves, cables, and linkages, where applicable, and be representative for the operation conditions of these parts during the useful life of the vehicle if used under normal conditions and serviced in accordance with the manufacturer's recommendations. The accumulated distance and operation conditions of the type V durability test may be regarded as representative for the useful life of the vehicle;'

(3) Annex VI is amended as follows:

(a) point 3.1.2 is replaced by the following:

'3.1.2. Multiple type I emission tests shall be conducted during the full distance accumulation phase with a frequency and amount of type I test procedures at the choice of the manufacturer and to the satisfaction of the technical service and approval authority. The type I emission test results shall provide sufficient statistical relevance to identify the deterioration trend, which shall be representative of the vehicle type with regard to environmental performance as placed on the market (see Figure 5-1).

Figure 5-1

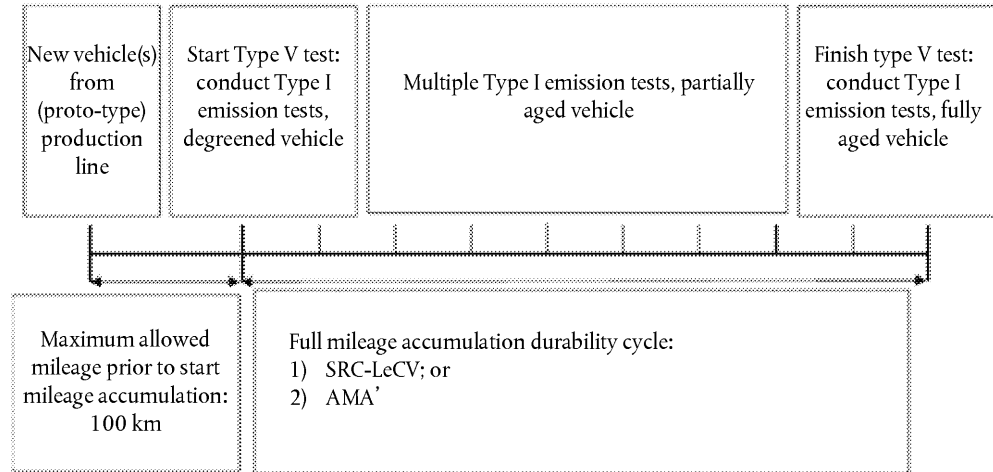
Test type V — durability test procedure with full distance accumulation

(b) point 3.2.2 is replaced by the following:

3.2.2. Multiple type I emission tests shall be conducted during the partial distance accumulation phase, with the frequency and number of type I test procedures chosen by the manufacturer. The type I emission test results shall provide sufficient statistical relevance to identify the deterioration trend, which shall be representative of the vehicle type with regard to the environmental performance placed on the market (see Figure 5-2).

Figure 5-2

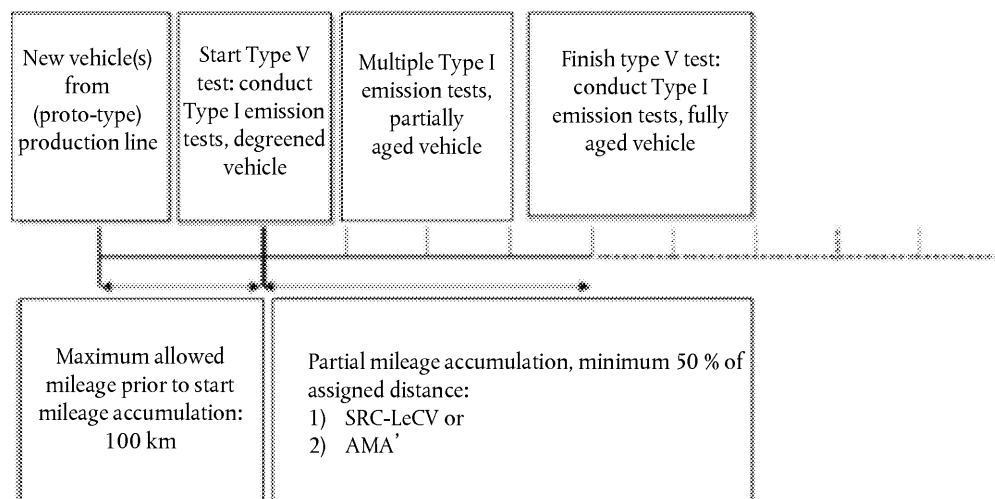
Test type V — accelerated durability test procedure with partial distance accumulation

(c) Appendix 1 is amended as follows:

(i) point 2.6 is replaced by the following:

‘2.6. Vehicle classification for the type V test

2.6.1. For the purpose of accumulating distance in the SRC-LeCV, the L-vehicle categories shall be grouped in accordance with Table Ap1-1.

Table Ap1-1

L-vehicle category groups for the SRC-LeCV

Cycle	WMTC Class	1) Vehicle maximum design speed (km/h)	2) Maximum net or continuous rated power (kW)
1	1	$v_{\max} \leq 50$ km/h	≤ 6 kW
2		50 km/h $< v_{\max} < 100$ km/h	< 14 kW
3	2	100 km/h $\leq v_{\max} < 130$ km/h	≥ 14 kW
4	3	130 km/h $\leq v_{\max}$	—

where:

V_d = engine displacement volume in cm³

v_{\max} = maximum design vehicle speed in km/h

2.6.2. The application of the vehicle classification criteria in Table Ap1-1 shall be performed by applying the following classification criteria hierarchy:

- (1) Maximum design vehicle speed (km/h);
- (2) maximum net or continuous rated power (kW).

2.6.3. If

- (a) the acceleration capability of the L-category vehicle is not sufficient to carry out the acceleration phases within the prescribed distances; or
- (b) the prescribed maximum vehicle speed in the individual cycles cannot be achieved owing to a lack of propulsion power; or
- (c) the maximum design vehicle speed is restricted to a vehicle speed lower than the prescribed SRC-LeCV vehicle speed

the vehicle shall be driven with the accelerator device fully open until the vehicle speed prescribed for the test cycle is reached or until the limited maximum design vehicle speed is reached. Subsequently the test cycle shall be carried out as prescribed for the vehicle category. Significant or frequent deviations from the prescribed vehicle speed tolerance band and the associated justification shall be reported to the approval authority and be included in the type V test report.’;

(ii) point 2.7.3.4. is replaced by the following:

‘2.7.3.4. coast-through deceleration: full let-off of the throttle, clutch engaged and in gear, no foot/hand control actuated, no brakes applied. If the target speed is 0 km/h (idle) and if the actual vehicle speed is ≤ 5 km/h, the clutch may be disengaged, the gear shifted to neutral and the brakes used in order to prevent engine stall and to entirely stop the vehicle. An upshift is not allowed during a coast-through deceleration. The rider may downshift to increase the braking effect of the engine. During gear changes, extra care shall be afforded to ensure that the gear change is performed promptly, with minimum (i.e. < 2 seconds) coasting in neutral gear, clutch and partial clutch use. The vehicle manufacturer may request to extend this time with the agreement of the approval authority if absolutely necessary.’;

(4) Annex VII is amended as follows:

(a) the title is replaced by the following:

‘Test type VII requirements on energy efficiency: CO₂ emissions, fuel consumption, electric energy consumption and electric range’;

(b) in Appendix 1, points 1.4.3.1. and 1.4.3.2. are replaced by the following:

‘1.4.3.1. for vehicles with a positive ignition engine fuelled with petrol (E5):

Equation Ap1-1:

$$FC = (0,118/D) \cdot ((0,848 \cdot HC) + (0,429 \cdot CO) + (0,273 \cdot CO_2))$$

where HC, CO and CO₂ tailpipe emissions in g/km.

1.4.3.2. for vehicles with a positive ignition engine fuelled with LPG:

Equation Ap1-2:

$$FC_{\text{norm}} = (0,1212/0,538) \cdot ((0,825 \cdot HC) + (0,429 \cdot CO) + (0,273 \cdot CO_2))$$

where HC, CO and CO₂ tailpipe emissions in g/km.

If the composition of the fuel used for the test differs from that assumed for the calculation of normalised consumption, a correction factor (cf) may be applied at the manufacturer’s request, as follows:

Equation Ap1-3:

$$FC_{\text{norm}} = (0,1212/0,538) \cdot (cf) \cdot ((0,825 \cdot HC) + (0,429 \cdot CO) + (0,273 \cdot CO_2))$$

where HC, CO and CO₂ tailpipe emissions in g/km.

The correction factor is determined as follows:

Equation Ap1-4:

$$cf = 0,825 + 0,0693 \cdot n_{\text{actual}};$$

where:

n_{actual} = the actual H/C ratio of the fuel used.’;

(c) Appendix 3 is amended as follows:

(i) point 3.4.1. is replaced by the following:

‘3.4.1. The CO₂ values shall be:

Equation Ap3-5:

$$M_1 = m_1/D_{\text{test1}} \text{ (g/km) and}$$

Equation Ap3-6:

$$M_2 = m_2/D_{\text{test}2} \text{ (g/km)}$$

where

$D_{\text{test}1}$ and $D_{\text{test}2}$ = the actual distances driven in the tests performed under Conditions A (point 3.2.) and B (point 3.3.) respectively, and

m_1 and m_2 = test results determined in points 3.2.3.5. and 3.3.2.5. respectively.;

(ii) point 4.4.1. is replaced by the following:

‘The CO₂ values shall be:

Equation Ap3-20:

$$M_1 = m_1/D_{\text{test}1} \text{ (g/km) and}$$

Equation Ap3-21:

$$M_2 = m_2/D_{\text{test}2} \text{ (g/km)}$$

where:

$D_{\text{test}1}$ and $D_{\text{test}2}$ = the actual distances driven in the tests performed under Conditions A (point 4.2.) and B (point 4.3.) respectively, and

m_1 and m_2 = test results determined in points 4.2.4.5. and 4.3.2.5. respectively.;

(d) in Appendix 3.3., point 1 is replaced by the following:

‘1. Measurement of the electric range

1.1. The following test method set out in point 4 shall be used to measure the electric range, expressed in km, of vehicles powered by an electric power train only or the electric range and OVC range of vehicles powered by a hybrid electric powertrain with off-vehicle charging (OVC HEV) as defined in Appendix 3.

1.2. Category L1e vehicles designed to pedal referred to in Annex I to Regulation (EU) No 168/2013 and in point 1.1.2. of Annex XIX to Regulation (EU) No 3/2014 shall be exempted from the electric range test.;

(5) Annex IX is amended as follows:

(a) the following points 2.3. to 2.4.3. are inserted:

‘2.3. Multi-mode noise abatement system

2.3.1. L-category vehicles equipped with a manually or electronically controlled, multiple mode, adjustable exhaust silencer system shall be tested in all modes.

2.3.2 For vehicles equipped with a noise abatement system as referred to in point 2.9.1. the reported sound pressure level shall be for the mode having the highest average sound pressure level.

2.4. Requirements related to anti-tampering and manually or electronically adjustable multi-mode exhaust or silencing systems

2.4.1. All exhaust or silencing systems shall be constructed in a way that does not easily permit removal of baffles, exit-cones and other parts functioning primarily as part of the silencing/expansion chambers. Where incorporation of such a part is unavoidable, its method of attachment shall be such that removal is not facilitated (e.g. with conventional threaded fixings) and shall also be attached so that removal causes permanent/irrecoverable damage to the exhaust silencer assembly.

2.4.2. Exhaust or silencing systems with manually or electronically controlled, multiple adjustable operating modes shall meet all applicable requirements in all operating modes. The reported noise levels at type-approval shall be those resulting from the mode with the highest noise levels.

2.4.3. The manufacturer shall not intentionally alter, adjust, or introduce any device or procedure solely for the purpose of fulfilling the sound requirements to obtain type-approval, which will not be operational during typical on-road operation.;

(b) in Appendix 3, point 2.4.1.1. is replaced by the following:

‘2.4.1.1. Absorbent fibrous material shall be asbestos-free and may be used in the construction of silencers only if it is held securely in place throughout the service life of the silencer and it meets the requirements of either point 2.4.1.2, 2.4.1.3 or 2.4.1.4.’;

(6) Annex X is amended as follows:

(a) Appendix 2.1. is amended as follows:

(i) point 2.1.2. is replaced by the following:

‘2.1.2.

Table Ap2.1-1

Accessories to be fitted during the propulsion unit performance test in order to determine torque and net engine power

No	Accessories	Fitted for the torque and net power test
1	Air intake system — Induction manifold — Air filter — Induction silencer — Crankcase emission-control system — Electrical control device, where fitted	If series-mounted: yes
2	Exhaust system — Manifold — Pipe work ⁽¹⁾ — Silencer ⁽¹⁾ — Exhaust pipe ⁽¹⁾ — Electrical control device, where fitted	If series-mounted: yes
3	Carburettor	If series-mounted: yes
4	Fuel injection system — Upstream filter — Filter — Fuel supply pump and high pressure pump if applicable — Compressed air pump in the case of DI air assist — Pipe work — Injector — Air inlet flap ⁽²⁾ , where fitted — Fuel pressure/flow regulator, where fitted	If series-mounted: yes

No	Accessories	Fitted for the torque and net power test
5	Maximum rotational speed-or power governors	If series-mounted: yes
6	Liquid-cooling equipment — Radiator — Fan ⁽³⁾ — Water Pump — Thermostat ⁽⁴⁾	If series-mounted: yes ⁽⁵⁾
7	Air cooling — Cowl — Blower ⁽³⁾ — Cooling temperature-regulating device(s) — Auxiliary bench blower	If series-mounted: yes
8	Electrical equipment	If series-mounted: yes ⁽⁶⁾
9	Pollution-control devices ⁽⁷⁾	If series-mounted: yes
9	Lubrication system — Oil feeder	If series-mounted: yes

⁽¹⁾ If it is difficult to use the standard exhaust system, an exhaust system causing an equivalent pressure drop may be fitted for the test with the agreement of the manufacturer. In the test laboratory when the engine is in operation, the exhaust gas extraction system shall not cause in the extraction flue at the point where it is connected to the vehicle's exhaust system a pressure differing from atmospheric pressure by ± 740 Pa (7,40 mbar), unless, before the test, the manufacturer accepts a higher back pressure.

⁽²⁾ The air inlet flap shall be that which controls the pneumatic inject pump regulator.

⁽³⁾ Where a fan or blower may be disengaged, the net engine power shall first of all be stated with the fan (or blower) disengaged, followed by the net engine power with the fan (or blower) engaged. Where a fixed electrically or mechanically-operated fan cannot be fitted on the test bench, the power absorbed by that fan shall be determined at the same rotational speeds as those used when the engine power is measured. That power is deducted from the corrected power in order to obtain the net power.

⁽⁴⁾ The thermostat may be locked in the fully open position.

⁽⁵⁾ The radiator, fan, fan nozzle, water pump and thermostat shall, on the test bench, occupy as far as possible the same position relative to each other as if they were on the vehicle. If the radiator, fan, fan nozzle, water pump or thermostat have a position on the test bench which is different from that on the vehicle, this shall be described and noted in the test report. The liquid coolant shall be circulated solely by the water pump for the engine. It may be cooled either by the engine radiator or by an outside circuit, provided that the pressure drops within that circuit remain substantially the same as those in the engine cooling system. If fitted, the engine blind shall be open.

⁽⁶⁾ Minimum generator output: the generator supplies the current that is strictly needed to supply the accessories that are essential to the operation of the engine. The battery shall not receive any charge during the test.

⁽⁷⁾ Anti-pollution provisions may include, for example, exhaust-gas recirculation (EGR) system, catalytic converter, thermal reactor, secondary air-supply system and fuel-evaporation protecting system.

(ii) point 3.4. is replaced by the following:

'3.4. Determination of the correction factor for mechanical efficiency of the transmission α_2

Where:

— the measuring point is the output side of the crankshaft, this factor is equal to 1;

- the measuring point is not the output side of the crankshaft, this factor is calculated using the formula:

Equation Ap2.1-3:

$$\alpha_2 = \frac{1}{n_t}$$

where n_t is the efficiency of the transmission located between the crankshaft and the measuring point.

This transmission efficiency n_t is determined from the product (multiplication) of efficiency n_j of each of the components of the transmission:

Equation Ap2.1-4:

$$n_t = n_1 \cdot n_2 \cdot \dots \cdot n_j;$$

(b) Appendix 4. is amended as follows:

(i) Point 3.3. is replaced by the following:

‘3.3. Test procedure to measure the switch-off distance

After stopping with pedalling, the assistance of the motor shall switch off in a driving distance ≤ 3 m. The testing vehicle speed is 90 % of the maximum assistance speed. The measurements shall be taken in accordance with EN 15194:2009. For vehicles fitted with an assistance modulator, it shall not be activated during the test.’;

(ii) Points 3.3.1. to 3.3.5.10. are deleted;

(iii) Points 3.4. to 3.4.3. are replaced by the following:

‘3.4. Test procedure to measure the maximum assistance factor

3.4.1. The ambient temperature shall be between 278,2 K and 318,2 K.

3.4.2. The test vehicle shall be powered by its corresponding propulsion battery. The propulsion battery with maximum capacity shall be used for this test procedure.

3.4.3. The battery shall be fully charged using the charger to be specified by the vehicle manufacturer.’;

(iv) The following points 3.4.4. to 3.4.9. are inserted:

‘3.4.4. One motor of the test bench shall be attached to the crank or crank axis of the test vehicle. This test bench crank motor shall simulate the driving action of the rider and shall be capable of running variable rotation speeds and torques. It shall reach a rotation frequency of 90 rpm and a maximum continuous rated torque of 50 Nm.

3.4.5. A brake or a motor simulating the losses and inertia of the vehicle shall be attached to a drum below the rear wheel of the test vehicle.

3.4.6. For vehicles equipped with a motor driving the front wheel, an additional brake or an additional motor shall be attached to a drum below the front wheel, simulating the losses and inertia of the vehicle.

3.4.7. If the assistance level of the vehicle is variable, it has to be set to maximum assistance.

3.4.8. The following points of operation shall be tested:

Table Ap4-1

operation points to test the maximum assistance factor

Point of operation	Simulated rider input power (+/- 10 %) in (W)	Target vehicle speed ⁽¹⁾ (+/- 10 %) in (km/h)	Desired pedalling cadence ⁽²⁾ in (rpm)
A	80	20	60
B	120	35	70
C	160	40	80

⁽¹⁾ If the target vehicle speed cannot be reached, the measurement shall be performed at the maximum vehicle speed reached.

⁽²⁾ Select gear closest to required rpm rate for the point of operation.

3.4.9. The maximum assistance factor shall be calculated according to the following formula:

Equation Ap4-1:

$$\text{Assistance factor} = \frac{\text{mechanical motor power of test vehicle}}{\text{simulated rider input power}}$$

where:

The mechanical motor power of the test vehicle shall be calculated from the sum of the mechanical brake motor power minus the mechanical input power of the test bench crank motor (in W).;

(v) Points 3.5. to 3.5.9. are deleted;

(7) Annex XI is amended as follows:

(a) point 3.1. is replaced by the following:

‘3.1. Test types I, II, V, VII and VIII (‘X’ in Table 11-1 means ‘applicable’)

Table 11-1

Classification criteria propulsion family with regard to test types I, II, V, VII and VIII

#	Classification criteria description	Test type I	Test type II	Test type V	Test type VII	Test type VIII ⁽¹⁾	
						Stage I	Stage II
1.	Vehicle						
1.1.	category;	X	X	X	X	X	X
1.2.	sub-category;	X	X	X	X	X	X

#	Classification criteria description	Test type I	Test type II	Test type V	Test type VII	Test type VIII (1)	
						Stage I	Stage II
1.3.	the inertia of a vehicle variant(s) or version(s) within two inertia categories above or below the nominal inertia category;	X		X	X	X	X
1.4.	overall gear ratios (+/- 8 %);	X		X	X	X	X
2.	Propulsion family characteristics						
2.1.	number of engines or electric motors;	X	X	X	X	X	X
2.2.	hybrid operation mode(s) (parallel/sequential/other);	X	X	X	X	X	X
2.3.	number of cylinders of the combustion engine;	X	X	X	X	X	X
2.4.	engine capacity (+/- 2 %) (2) of the combustion engine;	X	X	X	X	X	X
2.5.	number and control (variable cam phasing or lift) of combustion engine valves;	X	X	X	X	X	X
2.6.	monofuel/bifuel/flex fuel H ₂ NG/multifuel;	X	X	X	X	X	X
2.7.	fuel system (carburettor/scavenging port/port fuel injection/direct fuel injection/common rail/pump-injector/other);	X	X	X	X	X	X
2.8.	fuel storage (3);					X	X
2.9.	type of cooling system of combustion engine;	X	X	X	X	X	X
2.10.	combustion cycle (PI/CI/two-stroke/four-stroke/other);	X	X	X	X	X	X
2.11.	intake air system (naturally aspirated/charged (turbo-charger/super-charger)/intercooler/boost control) and air induction control (mechanical throttle/electronic throttle control/no throttle);	X	X	X	X	X	X
3.	Pollution control system characteristics						
3.1.	propulsion exhaust (not) equipped with catalytic converter(s);	X	X	X	X		X
3.2.	catalytic converter(s) type;	X	X	X	X		X
3.2.1.	number and elements of catalytic converters;	X	X	X	X		X
3.2.2.	size of catalytic converters (volume of monolith(s) +/- 15 %);	X	X	X	X		X

#	Classification criteria description	Test type I	Test type II	Test type V	Test type VII	Test type VIII ⁽¹⁾	
						Stage I	Stage II
3.2.3.	operation principle of catalytic activity (oxidising, three-way, heated, SCR, other.);	X	X	X	X		X
3.2.4.	precious metal load (identical or higher);	X	X	X	X		X
3.2.5.	precious metal ratio (+/- 15 %);	X	X	X	X		X
3.2.6.	substrate (structure and material);	X	X	X	X		X
3.2.7.	cell density;	X	X	X	X		X
3.2.8.	type of casing for the catalytic converter(s);	X	X	X	X		X
3.3.	propulsion exhaust (not) equipped with particulate filter (PF);	X	X	X	X		X
3.3.1.	PF types;	X	X	X	X		X
3.3.2.	number and elements of PF;	X	X	X	X		X
3.3.3.	size of PF (volume of filter element +/- 10 %);	X	X	X	X		X
3.3.4.	operation principle of PF (partial/wall-flow/other);	X	X	X	X		X
3.3.5.	active surface of PF;	X	X	X	X		X
3.4.	propulsion (not) equipped with periodically regenerating system;	X	X	X	X		X
3.4.1.	periodically regenerating system type;	X	X	X	X		X
3.4.2.	operation principle of periodically regenerating system;	X	X	X	X		X
3.5.	propulsion (not) equipped with selective catalytic converter reduction (SCR) system;	X	X	X	X		X
3.5.1.	SCR system type;	X	X	X	X		X
3.5.2.	operation principle of periodically regenerating system;	X	X	X	X		X
3.6.	propulsion (not) equipped with lean NO _x trap/absorber;	X	X	X	X		X
3.6.1.	lean NO _x trap/absorber type;	X	X	X	X		X
3.6.2.	operation principle of lean NO _x trap/absorber;	X	X	X	X		X

#	Classification criteria description	Test type I	Test type II	Test type V	Test type VII	Test type VIII ⁽¹⁾	
						Stage I	Stage II
3.7.	propulsion (not) equipped with a cold-start device or starting aid device(s);	X	X	X	X		X
3.7.1.	cold-start or starting aid device type;	X	X	X	X		X
3.7.2.	operation principle of cold start or starting aid device(s);	X	X	X	X	X	X
3.7.3.	Activation time of cold-start or starting aid device(s) and/or duty cycle (only limited time activated after cold start/continuous operation);	X	X	X	X	X	X
3.8.	propulsion (not) equipped with O ₂ sensor for fuel control;	X	X	X	X	X	X
3.8.1.	O ₂ sensor types;	X	X	X	X	X	X
3.8.2.	operation principle of O ₂ sensor (binary/wide range/other);	X	X	X	X	X	X
3.8.3.	O ₂ sensor interaction with closed-loop fuelling system (stoichiometry/lean or rich operation);	X	X	X	X	X	X
3.9.	propulsion (not) equipped with exhaust gas recirculation (EGR) system;	X	X	X	X		X
3.9.1.	EGR system types;	X	X	X	X		X
3.9.2.	operation principle of EGR system (internal/external);	X	X	X	X		X
3.9.3.	maximum EGR rate (+/- 5 %);	X	X	X	X		X

Explanatory notes:

(¹) The same family criteria also apply to functional on-board diagnostics set out in Annex XII of Regulation (EU) No 44/2014.

(²) maximum 30 % acceptable for test type VIII

(³) Only for vehicles equipped with storage for gaseous fuel'

(b) in point 3.2., the heading of Table 11-2 is replaced by the following:

Table 11-2

Classification criteria propulsion family with regard to test types III and IV'