

Regulation (EU) 2019/1009 of the European Parliament and of the Council of 5 June 2019 laying down rules on the making available on the market of EU fertilising products and amending Regulations (EC) No 1069/2009 and (EC) No 1107/2009 and repealing Regulation (EC) No 2003/2003 (Text with EEA relevance)

REGULATION (EU) 2019/1009 OF THE EUROPEAN
PARLIAMENT AND OF THE COUNCIL

of 5 June 2019

laying down rules on the making available on the market of EU fertilising products and amending Regulations (EC) No 1069/2009 and (EC) No 1107/2009 and repealing Regulation (EC) No 2003/2003

(Text with EEA relevance)

THE EUROPEAN PARLIAMENT AND THE COUNCIL OF THE EUROPEAN UNION,

Having regard to the Treaty on the Functioning of the European Union, and in particular Article 114 thereof,

Having regard to the proposal from the European Commission,

After transmission of the draft legislative act to the national parliaments,

Having regard to the opinion of the European Economic and Social Committee⁽¹⁾,

Acting in accordance with the ordinary legislative procedure⁽²⁾,

Whereas:

- (1) The conditions for making fertilisers available on the internal market have been partially harmonised through Regulation (EC) No 2003/2003 of the European Parliament and of the Council⁽³⁾, which almost exclusively covers fertilisers from mined or chemically produced, inorganic materials. There is also a need to make use of recycled or organic materials for fertilising purposes. Harmonised conditions for making fertilisers made from such recycled or organic materials available on the entire internal market should be established in order to provide an important incentive for their further use. Promoting increased use of recycled nutrients would further aid the development of the circular economy and allow a more resource-efficient general use of nutrients, while reducing Union dependency on nutrients from third countries. The scope of the harmonisation should therefore be extended in order to include recycled and organic materials.
- (2) Certain products are being used in combination with fertilisers for the purpose of improving nutrition efficiency, with the beneficial effect of reducing the amount of fertilisers used and hence their environmental impact. In order to facilitate their free movement on the internal market, not only fertilisers, i.e. products intended to provide plants with nutrient, but also products intended to improve plants' nutrition efficiency, should be covered by the harmonisation.

Status: Point in time view as at 05/06/2019.

Changes to legislation: There are currently no known outstanding effects for the Regulation (EU) 2019/1009 of the European Parliament and of the Council. (See end of Document for details)

- (3) Regulation (EC) No 765/2008 of the European Parliament and of the Council⁽⁴⁾ lays down rules on the accreditation of conformity assessment bodies, provides a framework for the market surveillance of products and for controls on products from third countries, and lays down the general principles of the CE marking. That Regulation should be applicable to products covered by this Regulation in order to ensure that products benefiting from the free movement of goods within the Union fulfil requirements providing a high level of protection of public interests such as human, animal and plant health, safety and the environment.
- (4) Decision No 768/2008/EC of the European Parliament and of the Council⁽⁵⁾ lays down common principles and reference provisions intended to apply across sectoral legislation in order to provide a coherent basis for revision or recasts of that legislation. Regulation (EC) No 2003/2003 should therefore be replaced by this Regulation, drafted to the extent possible in accordance with those common principles and reference provisions.
- (5) Contrary to most other product harmonisation measures in Union law, Regulation (EC) No 2003/2003 does not prevent non-harmonised fertilisers from being made available on the internal market in accordance with national law and the general free movement rules of the Treaty on the Functioning of the European Union (TFEU). In view of the very local nature of certain product markets, this possibility should remain. Compliance with harmonised rules should therefore remain optional, and should be required only for products, intended to provide plants with nutrient or improve plants' nutrition efficiency, which are CE marked when made available on the market. This Regulation should therefore not apply to products which are not CE marked when made available on the market.
- (6) Different product functions warrant different product safety and quality requirements adapted to their different intended uses. EU fertilising products should therefore be divided into different product function categories, which should each be subject to specific safety and quality requirements.
- (7) An EU fertilising product might have more than one of the functions described in the product function categories set out in this Regulation. Where only one of those functions is claimed, it should be sufficient for the EU fertilising product to comply with the requirements of the product function category describing that claimed function. By contrast, where more than one of those functions are claimed, the EU fertilising product should be regarded as a blend of two or more component EU fertilising products, and compliance should be required for each of the component EU fertilising products with respect to its function. A specific product function category should therefore cover such blends.
- (8) A manufacturer using one or more EU fertilising products that have already been subject to a conformity assessment, by that manufacturer or another manufacturer, might wish to rely on that conformity assessment. For the purpose of reducing the administrative burden to a minimum, the resulting EU fertilising product should also be regarded as a blend of two or more component EU fertilising products, and the additional conformity

Status: Point in time view as at 05/06/2019.

Changes to legislation: There are currently no known outstanding effects for the Regulation (EU) 2019/1009 of the European Parliament and of the Council. (See end of Document for details)

requirements for the blend should be limited to the aspects that are warranted by the blending.

- (9) Different component materials warrant different process requirements and control mechanisms adapted to their different potential hazardousness and variability. Component materials for EU fertilising products should therefore be divided into different categories, which should each be subject to specific process requirements and control mechanisms. It should be possible to make available on the market an EU fertilising product composed of several component materials from various component material categories, where each material complies with the requirements of the category to which the material belongs.
- (10) Contaminants in EU fertilising products, such as cadmium, could pose a risk to human, animal or plant health, to safety or to the environment as they accumulate in the environment and enter the food chain. Their content should therefore be limited in such products. Furthermore, impurities in EU fertilising products derived from bio-waste, in particular polymers but also metal and glass, should be either prevented or limited to the extent technically feasible by detection of such impurities in separately collected bio-waste before processing.
- (11) Several Member States have in place national provisions limiting cadmium content in phosphate fertilisers on grounds relating to the protection of human health and of the environment. Should a Member State deem it necessary to maintain such national provisions after the adoption of harmonised limit values under this Regulation, and until those harmonised limit values are equal to or lower than the national limit values already in place, it should notify them to the Commission in accordance with Article 114(4) TFEU. Furthermore, in accordance with Article 114(5) TFEU, if a Member State deems it necessary to introduce new national provisions, such as provisions limiting cadmium content in phosphate fertilisers, based on new scientific evidence relating to the protection of the environment or the working environment on grounds of a problem specific to that Member State arising after the adoption of this Regulation, it should notify the Commission of the envisaged provisions as well as the grounds for introducing them. In either case, the Commission should verify in accordance with Article 114(6) TFEU whether or not the notified national provisions are a means of arbitrary discrimination, a disguised restriction on trade or an obstacle to the functioning of the internal market.
- (12) In view of the fact that certain Member States have been granted derogations from Article 5 of Regulation (EC) No 2003/2003 in accordance with TFEU relating to cadmium content in fertilisers on the grounds, inter alia, of the protection of human health and the environment in the context of particular soil and climactic conditions prevailing in those Member States, and since the factual circumstances that led to the granting of those derogations by the Commission remain valid, those Member States should be able to continue to apply their national limit values for cadmium content until such time as harmonised limit values for cadmium content in phosphate fertilisers which are equal to or lower than those limit values are applicable at Union level.

Status: Point in time view as at 05/06/2019.

Changes to legislation: There are currently no known outstanding effects for the Regulation (EU) 2019/1009 of the European Parliament and of the Council. (See end of Document for details)

- (13) In order to facilitate the compliance of phosphate fertilisers with the requirements of this Regulation and to boost innovation, sufficient incentives should be provided for the development of relevant technologies, particularly decadmiation technology, and for the management of cadmium-rich hazardous waste in the form of relevant financial resources such as those available under Horizon Europe, the Circular Economy Finance Support Platform or through the European Investment Bank. Those incentives should target cadmium removal solutions that will be economically viable on an industrial scale and allow appropriate treatment of the waste generated.
- (14) An EU fertilising product complying with the requirements of this Regulation should be allowed to move freely on the internal market. Where one or more of the component materials is a derived product within the meaning of Regulation (EC) No 1069/2009 of the European Parliament and of the Council⁽⁶⁾, but has reached a point in the manufacturing chain beyond which it no longer poses any significant risk to human, animal or plant health, to safety or to the environment (the ‘end point in the manufacturing chain’), to continue subjecting the product to the provisions of that Regulation would represent an unnecessary administrative burden. Such fertilising products should therefore be excluded from the requirements of that Regulation. Regulation (EC) No 1069/2009 should therefore be amended accordingly.
- (15) For each component material category which includes derived products within the meaning of Regulation (EC) No 1069/2009, the end point in the manufacturing chain should be determined in accordance with the procedures laid down in that Regulation. Where such an end point is reached before the EU fertilising product is placed on the market but after the manufacturing process regulated under this Regulation has started, the process requirements of both Regulation (EC) No 1069/2009 and this Regulation should apply cumulatively to EU fertilising products, which means application of the stricter requirement in case both Regulations regulate the same parameter.
- (16) Derived products within the meaning of Regulation (EC) No 1069/2009 which are already placed on the market and used in the Union as organic fertilisers and soil improvers in accordance with that Regulation constitute promising raw materials for the production of innovative fertilising products in a circular economy. As soon as an end point in the manufacturing chain has been determined for the respective derived product, the EU fertilising products containing such derived products in accordance with this Regulation should be granted free movement on the internal market without being subject to the requirements of Regulation (EC) No 1069/2009. For this purpose, the Commission should, without undue delay, carry out a first assessment to check whether an end point in the manufacturing chain can be determined.
- (17) In the event of risks to public or animal health from fertilising products derived from animal by-products, recourse to safeguard measures in accordance with Regulation (EC) No 178/2002 of the European Parliament and of the Council⁽⁷⁾ should be possible, as is the case for other categories of products derived from animal by-products.
- (18) The making available on the market of an animal by-product or a derived product within the meaning of Regulation (EC) No 1069/2009 for which no end point in the manufacturing chain has been determined, or for which the determined end point has

Status: Point in time view as at 05/06/2019.

Changes to legislation: There are currently no known outstanding effects for the Regulation (EU) 2019/1009 of the European Parliament and of the Council. (See end of Document for details)

not been reached at the time of making available on the market, is subject to the requirements of that Regulation. Therefore, it would be misleading to provide for the product's CE marking under this Regulation. Any product containing or consisting of such an animal by-product or derived product should therefore be excluded from the scope of this Regulation. Untreated animal by-products should not be subject to this Regulation.

- (19) For certain recovered wastes, such as struvite, biochar and ash-based products, within the meaning of Directive 2008/98/EC of the European Parliament and of the Council⁽⁸⁾, a market demand for their use as fertilising products has been identified. Furthermore, certain requirements are necessary for the waste used as input in the recovery operation and for the treatment processes and techniques, as well as for fertilising products resulting from the recovery operation, in order to ensure that the use of those fertilising products does not lead to overall adverse environmental or human health impacts. For EU fertilising products, those requirements should be laid down in this Regulation. Therefore, as of the moment of compliance with all the requirements of this Regulation, such products should cease to be regarded as waste within the meaning of Directive 2008/98/EC, and it should, therefore, be possible for fertilising products containing or consisting of such recovered waste materials to access the internal market. To ensure legal certainty, take advantage of technical developments, and further stimulate the incentive among producers to make more use of valuable waste streams, the scientific analyses and the setting of recovery requirements at Union level for such products should start immediately after the entry into force of this Regulation. Accordingly, the power to adopt acts in accordance with Article 290 TFEU should be delegated to the Commission in respect of defining, without unnecessary delay, larger or additional categories of component materials eligible for use in the production of EU fertilising products.
- (20) Certain by-products within the meaning of Directive 2008/98/EC are currently used by manufacturers as components of fertilising products or can be expected to be used in future emerging markets. For such components, specific requirements should be laid down in a separate component material category in Annex II to this Regulation.
- (21) Certain substances and mixtures, commonly referred to as inhibitors, improve the nutrient release pattern of a nutrient in a fertiliser by delaying or stopping the activity of specific groups of micro-organisms or enzymes. For inhibitors made available on the market with the intention of them being added to fertilising products, the manufacturer should be responsible for ensuring that those inhibitors fulfil certain efficacy criteria. Therefore, those inhibitors should be considered as EU fertilising products under this Regulation. Furthermore, EU fertilising products containing such inhibitors should be subject to certain efficacy, safety and environmental criteria. Such inhibitors should therefore also be regulated as component materials for EU fertilising products.
- (22) Certain substances, mixtures and micro-organisms, referred to as plant biostimulants, are not as such inputs of nutrients, but nevertheless stimulate plants' natural nutrition processes. Where such products aim solely at improving the plants' nutrient use efficiency, tolerance to abiotic stress, quality traits or increasing the availability of

Status: Point in time view as at 05/06/2019.

Changes to legislation: *There are currently no known outstanding effects for the Regulation (EU) 2019/1009 of the European Parliament and of the Council. (See end of Document for details)*

confined nutrients in the soil or rhizosphere, they are by nature more similar to fertilising products than to most categories of plant protection products. They act in addition to fertilisers, with the aim of optimising the efficiency of those fertilisers and reducing the nutrient application rates. Such products should therefore be eligible for CE marking under this Regulation and excluded from the scope of Regulation (EC) No 1107/2009 of the European Parliament and of the Council⁽⁹⁾. Regulation (EC) No 1107/2009 should therefore be amended accordingly.

- (23) Products with one or more functions, one of which is covered by the scope of Regulation (EC) No 1107/2009, are plant protection products falling within the scope of that Regulation. Those products should remain under the control developed for such products and provided for by that Regulation. Where such products also have the function of a fertilising product, it would be misleading to provide for their CE marking under this Regulation, since the making available on the market of a plant protection product is contingent on a product authorisation valid in the Member State concerned. Therefore, such products should be excluded from the scope of this Regulation.
- (24) This Regulation should not prevent the application of existing Union legislation relating to aspects of protection of human, animal and plant health, of safety and of the environment not covered by this Regulation. This Regulation should therefore apply without prejudice to Council Directive 86/278/EEC⁽¹⁰⁾, Council Directive 89/391/EEC⁽¹¹⁾, Council Directive 91/676/EEC⁽¹²⁾, Directive 2000/60/EC of the European Parliament and of the Council⁽¹³⁾, Directive 2001/18/EC of the European Parliament and of the Council⁽¹⁴⁾, Regulation (EC) No 852/2004 of the European Parliament and of the Council⁽¹⁵⁾, Regulation (EC) No 882/2004 of the European Parliament and of the Council⁽¹⁶⁾, Regulation (EC) No 1907/2006 of the European Parliament and of the Council⁽¹⁷⁾, Commission Regulation (EC) No 1881/2006⁽¹⁸⁾, Council Regulation (EC) No 834/2007⁽¹⁹⁾, Regulation (EC) No 1272/2008 of the European Parliament and of the Council⁽²⁰⁾, Regulation (EU) No 98/2013 of the European Parliament and of the Council⁽²¹⁾, Regulation (EU) No 1143/2014 of the European Parliament and of the Council⁽²²⁾, Regulation (EU) 2016/2031 of the European Parliament and of the Council⁽²³⁾, Directive (EU) 2016/2284 of the European Parliament and of the Council⁽²⁴⁾ and Regulation (EU) 2017/625 of the European Parliament and of the Council⁽²⁵⁾.
- (25) In line with common practice, nitrogen, phosphorus and potassium should be referred to as ‘primary macronutrients’, and calcium, magnesium, sodium and sulphur should be referred to as ‘secondary macronutrients’. Also in line with common practice, fertilisers should be referred to as ‘straight’ when they contain either only one macronutrient – regardless whether it is primary or secondary – or only one primary macronutrient in combination with one or more secondary macronutrients. In line with the same practice, fertilisers should be referred to as ‘compound’ when they contain either more than one primary macronutrient – regardless whether they also contain one or more secondary macronutrients – or contain no primary macronutrient but more than one secondary macronutrient.
- (26) Where an EU fertilising product contains a substance or mixture within the meaning of Regulation (EC) No 1907/2006, the safety of its constituent substances for the

Status: Point in time view as at 05/06/2019.

Changes to legislation: There are currently no known outstanding effects for the Regulation (EU) 2019/1009 of the European Parliament and of the Council. (See end of Document for details)

intended use should be established through registration pursuant to that Regulation. The information requirements should ensure that the safety of the intended use of the EU fertilising product is demonstrated in a manner comparable to that achieved through other regulatory regimes for products intended for use on arable soil or crops, notably Member States' national fertiliser legislation and Regulation (EC) No 1107/2009. Therefore, where the actual quantities placed on the market are lower than 10 tonnes per company per year, the information requirements determined by Regulation (EC) No 1907/2006 for the registration of substances in quantities of 10 to 100 tonnes should exceptionally apply as a condition for use in EU fertilising products. Those information requirements should apply to the actual substances contained in the EU fertilising product, as opposed to the precursors used for the manufacturing of those substances. The precursors themselves, such as sulphuric acid used as a precursor for the production of single superphosphate, should not be regulated as component materials for the purpose of this Regulation, since chemical safety will be better ensured by regulating as component materials the substances formed from the precursors and actually contained in the EU fertilising product. The obligation to comply with all the requirements of a component material category should therefore apply to those substances.

- (27) Where the actual quantities of substances in EU fertilising products regulated by this Regulation are higher than 100 tonnes, the additional information requirements laid down in Regulation (EC) No 1907/2006 should apply directly by virtue of that Regulation. The application of the other provisions of Regulation (EC) No 1907/2006 should also remain unaffected by this Regulation.
- (28) Economic operators should be responsible for the compliance of EU fertilising products with this Regulation, in relation to their respective roles in the supply chain, so as to ensure a high level of protection of the aspects of public interest covered by this Regulation, and also to guarantee fair competition on the internal market. Whenever appropriate, manufacturers and importers should carry out sample testing of the EU fertilising products that they have made available on the market, in order to protect the health and safety of consumers and the environment.
- (29) It is necessary to provide for a clear and proportionate distribution of obligations which correspond to the role of each economic operator in the supply and distribution chain.
- (30) The manufacturer, having detailed knowledge of the design and production process, is best placed to carry out the conformity assessment procedure. Conformity assessment of EU fertilising products should therefore remain solely the obligation of the manufacturer.
- (31) It is necessary to ensure that EU fertilising products from third countries that enter the internal market comply with this Regulation, and in particular that the appropriate conformity assessment procedures have been carried out by manufacturers with regard to those EU fertilising products. Provision should therefore be made for importers to make sure that EU fertilising products which they place on the market comply with the requirements of this Regulation and that they do not place on the market EU fertilising products which do not comply with such requirements or present a risk to human, animal or plant health, to safety or to the environment. Provision should also be made for such

Status: Point in time view as at 05/06/2019.

Changes to legislation: There are currently no known outstanding effects for the Regulation (EU) 2019/1009 of the European Parliament and of the Council. (See end of Document for details)

importers to make sure that conformity assessment procedures have been carried out and that marking of EU fertilising products and documentation drawn up by manufacturers are available for inspection by the competent national authorities.

- (32) When placing an EU fertilising product on the market, importers should indicate on the packaging of the EU fertilising product their name, registered trade name or registered trade mark and the postal address at which they can be contacted, in order to enable market surveillance.
- (33) Since distributors make an EU fertilising product available on the market after it has been placed on the market by the manufacturer or the importer, they should act with due care to ensure that their handling of the EU fertilising product does not adversely affect the compliance of that EU fertilising product with this Regulation.
- (34) Economic operators who either place an EU fertilising product on the market under their own name or trade mark or modify an EU fertilising product in such a way that compliance with this Regulation may be affected should be considered to be manufacturers and should assume the obligations of manufacturers. In other cases, economic operators who only package or repackage EU fertilising products already placed on the market by other economic operators should be able to prove that compliance with the requirements of this Regulation has not been affected, by indicating their identity on the package and by keeping a copy of the original labelling information.
- (35) Since distributors and importers are close to the market place, they should be involved in market surveillance tasks carried out by competent national authorities, and should be required to participate actively and provide those authorities with all necessary information relating to the EU fertilising product.
- (36) Ensuring traceability of an EU fertilising product throughout the whole supply chain helps to make market surveillance simpler and more efficient. An efficient traceability system facilitates market surveillance authorities' task of tracing economic operators who made non-compliant EU fertilising products available on the market. When keeping the information required for the identification of other economic operators, economic operators should not be required to update such information in respect of other economic operators who have either supplied them with an EU fertilising product or to whom they have supplied an EU fertilising product, since such updated information is normally not available to them.
- (37) In order to facilitate the assessment of conformity with the requirements of this Regulation it is necessary to provide for a presumption of conformity for EU fertilising products which are in conformity with harmonised standards that are adopted in accordance with Regulation (EU) No 1025/2012 of the European Parliament and of the Council⁽²⁶⁾ or with common specifications adopted in accordance with this Regulation.
- (38) In order to enable economic operators to demonstrate and the competent authorities to verify that EU fertilising products made available on the market comply with the requirements of this Regulation, it is necessary to provide for conformity assessment procedures. Decision No 768/2008/EC establishes modules for conformity assessment procedures, from the least stringent to the most stringent, in proportion to the level

Status: Point in time view as at 05/06/2019.

Changes to legislation: There are currently no known outstanding effects for the Regulation (EU) 2019/1009 of the European Parliament and of the Council. (See end of Document for details)

of risk involved and the level of safety required. In order to ensure inter-sectoral coherence and to avoid ad-hoc variants, conformity assessment procedures should be chosen from among those modules. It should be possible for manufacturers to choose a more stringent conformity assessment procedure for the assessment of an EU fertilising product eligible for a less stringent procedure, since this might enable the manufacturers to streamline their administration without jeopardising the conformity of the EU fertilising product. Furthermore, it is necessary to adapt the modules established by Decision No 768/2008/EC in order to reflect specific aspects of fertilising products. In particular, it is necessary to reinforce the quality systems and the involvement of notified bodies for the conformity assessment of certain EU fertilising products derived from recovered waste.

- (39) In order to ensure that ammonium nitrate fertilisers of high nitrogen content do not endanger safety, and that such fertilisers are not used for purposes other than those for which they are intended, for example as explosives, such fertilisers should be subject to specific requirements relating to detonation resistance testing and to traceability.
- (40) To ensure effective access to information for market surveillance purposes, information regarding conformity with all Union acts applicable to EU fertilising products should be given in the form of a single EU declaration of conformity. In order to reduce the administrative burden on economic operators, it should be possible for that single EU declaration of conformity to be a dossier made up of relevant individual declarations of conformity.
- (41) The CE marking, indicating the conformity of an EU fertilising product with this Regulation, is the visible consequence of a whole process comprising conformity assessment in a broad sense. General principles governing the CE marking and its relationship to other markings are set out in Regulation (EC) No 765/2008. Specific rules governing the affixing of the CE marking in the case of EU fertilising products should be laid down.
- (42) Certain conformity assessment procedures set out in this Regulation require the intervention of conformity assessment bodies, which are notified by the Member States to the Commission.
- (43) It is essential that all notified bodies perform their functions to the same level and under conditions of fair competition. That requires the setting of obligatory requirements for conformity assessment bodies wishing to be notified in order to provide conformity assessment services.
- (44) If a conformity assessment body demonstrates conformity with the criteria laid down in harmonised standards it should be presumed to comply with the corresponding requirements set out in this Regulation.
- (45) In order to ensure a consistent level of quality in the performance of conformity assessment of EU fertilising products, it is also necessary to set requirements for notifying authorities and other bodies involved in the assessment, notification and monitoring of notified bodies.

Status: Point in time view as at 05/06/2019.

Changes to legislation: There are currently no known outstanding effects for the Regulation (EU) 2019/1009 of the European Parliament and of the Council. (See end of Document for details)

- (46) The system set out in this Regulation should be complemented by the accreditation system provided for in Regulation (EC) No 765/2008. Since accreditation is an essential means of verifying the competence of conformity assessment bodies, it should also be used for the purposes of notification.
- (47) Due to the variable nature of certain component materials of EU fertilising products, and the potentially irreversible nature of some of the damage to which soil and crop exposure to impurities could lead, transparent accreditation as provided for in Regulation (EC) No 765/2008, ensuring the necessary level of confidence in certificates of conformity of EU fertilising products, should be the only means of demonstrating the technical competence of conformity assessment bodies.
- (48) Conformity assessment bodies frequently subcontract parts of their activities linked to the assessment of conformity or have recourse to a subsidiary. In order to safeguard the level of protection required for EU fertilising products to be placed on the market, it is essential that conformity assessment subcontractors and subsidiaries fulfil the same requirements as notified bodies in relation to the performance of conformity assessment tasks. Therefore, it is important that the assessment of the competence and the performance of bodies to be notified and the monitoring of bodies already notified cover also activities carried out by subcontractors and subsidiaries.
- (49) It is necessary to provide for an efficient and transparent notification procedure and, in particular, to adapt it to new technologies so as to enable online notification.
- (50) Since the services offered by notified bodies in a Member State might relate to EU fertilising products made available on the market throughout the Union, it is appropriate to give the other Member States and the Commission the opportunity to raise objections concerning a notified body. It is therefore important to provide for a period during which any doubts or concerns as to the competence of conformity assessment bodies can be clarified before they start operating as notified bodies.
- (51) In the interests of easing market access, it is crucial that notified bodies apply the conformity assessment procedures without creating unnecessary burdens for economic operators. For the same reason, and to ensure equal treatment of economic operators, consistency in the technical application of the conformity assessment procedures needs to be ensured. That can best be achieved through appropriate coordination and cooperation between notified bodies.
- (52) In order to ensure legal certainty, it is necessary to clarify that rules on internal market surveillance and control of products entering the internal market provided for in Regulation (EC) No 765/2008 apply to EU fertilising products covered by this Regulation. This Regulation should not prevent Member States from choosing the competent authorities to carry out those tasks.
- (53) EU fertilising products should be placed on the market only if they are sufficiently effective and do not present a risk to human, animal or plant health, to safety or to the environment when properly stored and used for their intended purpose, or under conditions of use which can be reasonably foreseen, that is when such use could result from lawful and readily predictable human behaviour.

Status: Point in time view as at 05/06/2019.

Changes to legislation: There are currently no known outstanding effects for the Regulation (EU) 2019/1009 of the European Parliament and of the Council. (See end of Document for details)

- (54) Regulation (EC) No 2003/2003 provides for a safeguard procedure allowing the Commission to examine the justification for a measure taken by a Member State against EC fertilisers considered to constitute a risk. In order to increase transparency and to reduce processing time, it is necessary to improve the existing safeguard procedure, with the view to making it more efficient and drawing on the expertise available in Member States.
- (55) The existing system should be supplemented by a procedure under which interested parties are informed of measures intended to be taken with regard to EU fertilising products presenting a risk to human, animal or plant health, to safety or to the environment. It should also allow market surveillance authorities, in cooperation with the relevant economic operators, to act at an early stage in respect of such EU fertilising products.
- (56) The obligations of market surveillance authorities under this Regulation to require economic operators to take corrective actions should only apply to fertilising products bearing the CE marking when they are made available on the market. Those obligations should therefore be without prejudice to any possibility existing under national law to allow the economic operator to remove the CE marking and to legally place the product on the market as a product not falling within the scope of this Regulation.
- (57) In order to achieve the objectives of this Regulation, the power to adopt acts in accordance with Article 290 TFEU should be delegated to the Commission in respect of adaptation to technical progress, in particular in the field of production of fertilising products derived from animal by-products and in the field of waste recovery, as well as in the agricultural sector and the agro-food industry.
- (58) Promising technical progress is being made in the field of recycling of waste, such as phosphorus recycling from sewage sludge, and fertilising product production from animal by-products, such as biochar. It should be possible for products containing or consisting of such materials to access the internal market without unnecessary delay when the manufacturing processes have been scientifically analysed and process requirements have been established at Union level. For that purpose, the power to adopt acts in accordance with Article 290 TFEU should be delegated to the Commission in respect of defining and introducing additional component materials eligible for use in the production of EU fertilising products and corresponding contaminant limit values in such products. That empowerment should only apply to the extent justified by technical progress established after the adoption of this Regulation, and not for the purpose of amending any elements of this Regulation in the absence of new evidence of such progress. In order to base the introduction of new contaminant limit values in EU fertilising products on full consideration of the direct and indirect impact on food and feed safety and on the environment, scientific opinions of the European Food Safety Authority, the European Chemicals Agency or the Commission's Joint Research Centre, as relevant, should be taken into account prior to the adoption of new contaminant limit values. For derived products within the meaning of the Regulation (EC) No 1069/2009, component material categories should be expanded or added only to the extent that an end point in the manufacturing chain has been determined in accordance with the

Status: Point in time view as at 05/06/2019.

Changes to legislation: There are currently no known outstanding effects for the Regulation (EU) 2019/1009 of the European Parliament and of the Council. (See end of Document for details)

procedures laid down in that Regulation, since derived products for which no such end point has been determined are in any event excluded from the scope of this Regulation.

- (59) Since micro-organisms are not subject to registration under Regulation (EC) No 1907/2006 or any other horizontal Union legislation requiring manufacturers to demonstrate that the intended use is safe, they should be eligible as component materials for EU fertilising products only to the extent that they have been clearly identified and supported by data demonstrating that their use is safe, and indicated in an exhaustive list adopted on that basis. The power to adopt acts in accordance with Article 290 TFEU should be delegated to the Commission in respect of adding new micro-organisms to that exhaustive list on the same basis.
- (60) An EU fertilising product can contain polymers other than nutrient polymers. However, this should be limited to cases where the purpose of the polymer is that of controlling the release of nutrients or increasing the water retention capacity or wettability of the EU fertilising product. It should be possible for innovative products containing such polymers to access the internal market. In order to minimise risks to human health, to safety or to the environment that may be posed by polymers other than nutrient polymers, the criteria for their biodegradability, so that they are capable of undergoing physical and biological decomposition, should be established. For that purpose, the power to adopt acts in accordance with Article 290 TFEU should be delegated to the Commission in respect of defining the criteria for the conversion of polymeric carbon into carbon dioxide and a related testing method. Polymers which do not comply with those criteria should be prohibited after a transitional period.
- (61) Furthermore, it should be possible to react immediately to new scientific evidence and to new risk assessments regarding human, animal or plant health, safety or the environment. For that purpose, the power to adopt acts in accordance with Article 290 TFEU should be delegated to the Commission to amend the requirements applicable to various categories of EU fertilising products.
- (62) When adopting delegated acts under this Regulation, it is of particular importance that the Commission carry out appropriate consultations during its preparatory work, including at expert level, and that those consultations be conducted in accordance with the principles laid down in the Interinstitutional Agreement of 13 April 2016 on Better Law-Making⁽²⁷⁾. In particular, to ensure equal participation in the preparation of delegated acts, the European Parliament and the Council receive all documents at the same time as Member States' experts, and their experts systematically have access to meetings of Commission expert groups dealing with the preparation of delegated acts.
- (63) In order to ensure uniform conditions for the implementation of this Regulation, implementing powers to adopt acts should be conferred on the Commission in order to determine whether measures taken by Member States in respect of non-compliant EU fertilising products are justified or not. Since those acts will relate to the question of whether national measures are justified, such acts should not be subject to control by the Member States.
- (64) In order to further ensure uniform conditions for the implementation of this Regulation, implementing powers should be conferred on the Commission. Those powers should be

Status: Point in time view as at 05/06/2019.

Changes to legislation: There are currently no known outstanding effects for the Regulation (EU) 2019/1009 of the European Parliament and of the Council. (See end of Document for details)

exercised in accordance with Regulation (EU) No 182/2011 of the European Parliament and of the Council⁽²⁸⁾.

- (65) The advisory procedure should be used for the adoption of implementing acts requiring the notifying Member State to take the necessary corrective measures in respect of notified bodies that do not meet or no longer meet the requirements for their notification.
- (66) The examination procedure should be used for the adoption of implementing acts laying down in common specifications uniform conditions for implementing the requirements of this Regulation and tests for verifying the conformity of EU fertilising products where harmonised standards have not been adopted, or do not satisfy the requirements of this Regulation, or where there are undue delays in the process of adopting or updating these standards; amending or repealing common specifications where non-compliance of EU fertilising products can be attributed to shortcomings in those common specifications; determining whether a national measure taken in respect of a compliant EU fertilising product that presents a risk to human, animal or plant health, to safety or to the environment is justified or not.
- (67) The Commission should adopt immediately applicable implementing acts determining whether a national measure taken in respect of a compliant EU fertilising product that presents a risk is justified or not where, in duly justified cases relating to the protection of human, animal or plant health, safety or the environment, imperative grounds of urgency so require.
- (68) Member States should lay down rules on penalties applicable to infringements of this Regulation and ensure that those rules are enforced. The penalties provided for should be effective, proportionate and dissuasive.
- (69) In view of the need to ensure a high level of environmental protection and the need to take into account new developments based on scientific facts, the Commission should submit to the European Parliament and to the Council a report which includes a review of the limit values for cadmium content.
- (70) It is necessary to provide for transitional arrangements that allow the making available on the market of EC fertilisers that have been placed on the market in accordance with Regulation (EC) No 2003/2003 before the date of application of this Regulation without those products having to comply with further product requirements. Distributors should therefore be able to supply EC fertilisers that have been placed on the market, namely stock that is already in the distribution chain, before the date of application of this Regulation.
- (71) It is necessary to provide for sufficient time for economic operators to comply with their obligations under this Regulation, and for Member States to set up the administrative infrastructure necessary for its application. The application should therefore be deferred to a date where those preparations can reasonably be finalised.
- (72) Since the objective of this Regulation, namely to guarantee the functioning of the internal market while ensuring that EU fertilising products on the market fulfil the requirements providing for a high level of protection of human, animal, and plant health, of safety and of the environment, cannot be sufficiently achieved by the Member States

Status: Point in time view as at 05/06/2019.

Changes to legislation: There are currently no known outstanding effects for the Regulation (EU) 2019/1009 of the European Parliament and of the Council. (See end of Document for details)

but can rather, by reason of its scale and effects, be better achieved at Union level, the Union may adopt measures, in accordance with the principle of subsidiarity as set out in Article 5 of the Treaty on European Union. In accordance with the principle of proportionality, as set out in that Article, this Regulation does not go beyond what is necessary in order to achieve that objective,

HAVE ADOPTED THIS REGULATION:

CHAPTER I **U.K.**

GENERAL PROVISIONS

Article 1 **U.K.**

Scope

1 This Regulation applies to EU fertilising products.

This Regulation does not apply to:

- a animal by-products or derived products which are subject to the requirements of Regulation (EC) No 1069/2009 when made available on the market;
- b plant protection products covered by the scope of Regulation (EC) No 1107/2009.

2 This Regulation does not affect the application of the following legal acts:

- a Directive 86/278/EEC;
- b Directive 89/391/EEC;
- c Directive 91/676/EEC;
- d Directive 2000/60/EC;
- e Directive 2001/18/EC;
- f Regulation (EC) No 852/2004;
- g Regulation (EC) No 882/2004;
- h Regulation (EC) No 1881/2006;
- i Regulation (EC) No 1907/2006;
- j Regulation (EC) No 834/2007;
- k Regulation (EC) No 1272/2008;
- l Regulation (EU) No 98/2013;
- m Regulation (EU) No 1143/2014;
- n Regulation (EU) 2016/2031;
- o Directive (EU) 2016/2284;
- p Regulation (EU) 2017/625.

Article 2 **U.K.**

Definitions

For the purposes of this Regulation, the following definitions apply:

- (1) ‘fertilising product’ means a substance, mixture, micro-organism or any other material, applied or intended to be applied on plants or their rhizosphere or on mushrooms or their mycosphere, or intended to constitute the rhizosphere or mycosphere, either on its own or mixed with another material, for the purpose of providing the plants or mushrooms with nutrient or improving their nutrition efficiency;
- (2) ‘EU fertilising product’ means a fertilising product which is CE marked when made available on the market;
- (3) ‘substance’ means a substance as defined in point 1 of Article 3 of Regulation (EC) No 1907/2006;
- (4) ‘mixture’ means a mixture as defined in point 2 of Article 3 of Regulation (EC) No 1907/2006;
- (5) ‘micro-organism’ means a micro-organism as defined in point 15 of Article 3 of Regulation (EC) No 1107/2009;
- (6) ‘liquid form’ means a suspension or a solution, where a suspension is a two-phase dispersion in which solid particles are maintained in suspension in the liquid phase, and a solution is a liquid that is free of solid particles, or a gel and includes pastes;
- (7) ‘solid form’ means form characterised by structural rigidity and resistance to changes of shape or volume and in which the atoms are tightly bound to each other, either in a regular geometric lattice (crystalline solids) or in an irregular manner (an amorphous solid);
- (8) ‘% by mass’ means a percentage of the mass of the entire EU fertilising product in the form in which it is made available on the market;
- (9) ‘making available on the market’ means any supply of an EU fertilising product for distribution or use on the Union market in the course of a commercial activity, whether in return for payment or free of charge;
- (10) ‘placing on the market’ means the first making available of an EU fertilising product on the Union market;
- (11) ‘manufacturer’ means any natural or legal person who manufactures an EU fertilising product or has an EU fertilising product designed or manufactured, and markets that EU fertilising product under his or her name or trademark;
- (12) ‘authorised representative’ means any natural or legal person established within the Union who has received a written mandate from a manufacturer to act on his or her behalf in relation to specified tasks;
- (13) ‘importer’ means any natural or legal person established within the Union who places an EU fertilising product from a third country on the Union market;
- (14) ‘distributor’ means any natural or legal person in the supply chain, other than the manufacturer or the importer, who makes an EU fertilising product available on the market;
- (15) ‘economic operators’ means the manufacturer, the authorised representative, the importer and the distributor;

Status: Point in time view as at 05/06/2019.

Changes to legislation: There are currently no known outstanding effects for the Regulation (EU) 2019/1009 of the European Parliament and of the Council. (See end of Document for details)

- (16) ‘technical specification’ means a document that prescribes technical requirements to be fulfilled by an EU fertilising product, by its production process or by the methods for its sampling and analysis;
- (17) ‘harmonised standard’ means harmonised standard as defined in point 1(c) of Article 2 of Regulation (EU) No 1025/2012;
- (18) ‘accreditation’ means accreditation as defined in point 10 of Article 2 of Regulation (EC) No 765/2008;
- (19) ‘national accreditation body’ means national accreditation body as defined in point 11 of Article 2 of Regulation (EC) No 765/2008;
- (20) ‘conformity assessment’ means the process demonstrating whether the requirements of this Regulation relating to an EU fertilising product have been fulfilled;
- (21) ‘conformity assessment body’ means a body that performs conformity assessment activities including testing, certification and inspection;
- (22) ‘recall’ means any measure aimed at achieving the return of an EU fertilising product that has already been made available to the end-user;
- (23) ‘withdrawal’ means any measure aimed at preventing an EU fertilising product in the supply chain from being made available on the market;
- (24) ‘Union harmonisation legislation’ means any Union legislation harmonising the conditions for the marketing of products;
- (25) ‘CE marking’ means a marking by which the manufacturer indicates that the EU fertilising product is in conformity with the applicable requirements set out in Union harmonisation legislation providing for its affixing.

Article 3 **U.K.**

Free movement

1 Member States shall not impede, for reasons relating to composition, labelling or other aspects covered by this Regulation, the making available on the market of EU fertilising products which comply with this Regulation.

2 By way of derogation from paragraph 1 of this Article, a Member State which, on 14 July 2019 benefits from a derogation from Article 5 of Regulation (EC) No 2003/2003 in relation to cadmium content in fertilisers granted in accordance with Article 114(4) TFEU may continue to apply the national limit values for cadmium content in fertilisers which are applicable in that Member State on 14 July 2019 to EU fertilising products until such time as harmonised limit values for cadmium content in phosphate fertilisers which are equal to or lower than the limit values applicable in the Member State concerned on 14 July 2019 are applicable at Union level.

3 This Regulation shall not prevent Member States from maintaining or adopting provisions for the purpose of protecting human health and the environment which are in compliance with the Treaties, concerning the use of EU fertilising products, provided that those provisions do not require modification of EU fertilising products which are in compliance with this Regulation and do not influence the conditions for making them available on the market.

Status: Point in time view as at 05/06/2019.

Changes to legislation: There are currently no known outstanding effects for the Regulation (EU) 2019/1009 of the European Parliament and of the Council. (See end of Document for details)

Article 4 **U.K.**

Product requirements

- 1 An EU fertilising product shall:
 - a meet the requirements set out in Annex I for the relevant product function category;
 - b meet the requirements set out in Annex II for the relevant component material category or categories; and
 - c be labelled in accordance with the labelling requirements set out in Annex III.
- 2 For any aspects not covered by Annex I or II, EU fertilising products shall not present a risk to human, animal or plant health, to safety or to the environment.
- 3 By 16 July 2020, the Commission shall publish a guidance document for manufacturers and market surveillance authorities with clear information and examples concerning the visual appearance of the label referred to in Annex III.

Article 5 **U.K.**

Making available on the market

EU fertilising products shall only be made available on the market if they comply with this Regulation.

CHAPTER II **U.K.**

OBLIGATIONS OF ECONOMIC OPERATORS

Article 6 **U.K.**

Obligations of manufacturers

- 1 When placing EU fertilising products on the market, manufacturers shall ensure that they have been designed and manufactured in accordance with the requirements set out in Annexes I and II.
- 2 Before placing EU fertilising products on the market, manufacturers shall draw up the technical documentation and carry out the relevant conformity assessment procedure referred to in Article 15, or have it carried out.

Where compliance of an EU fertilising product with the applicable requirements laid down in this Regulation has been demonstrated by that conformity assessment procedure, manufacturers shall draw up an EU declaration of conformity and affix the CE marking.

- 3 Manufacturers shall keep the technical documentation and the EU declaration of conformity for 5 years after the EU fertilising product covered by those documents has been placed on the market.

On request, manufacturers shall make a copy of the EU declaration of conformity available to other economic operators.

Status: Point in time view as at 05/06/2019.

Changes to legislation: There are currently no known outstanding effects for the Regulation (EU) 2019/1009 of the European Parliament and of the Council. (See end of Document for details)

4 Manufacturers shall ensure that procedures are in place for EU fertilising products that are part of a series production to remain in conformity with this Regulation. Changes in the production process or in the characteristics of those EU fertilising products and changes in the harmonised standards, common specifications referred to in Article 14 or other technical specifications by reference to which conformity of an EU fertilising product is declared or by application of which its conformity is verified shall be adequately taken into account.

When deemed appropriate with regard to the performance of, or the risks presented by, an EU fertilising product, manufacturers shall carry out sample testing of such EU fertilising products made available on the market, investigate, and, if necessary, keep a register of complaints, of non-conforming EU fertilising products and recalls of such EU fertilising products, and shall keep distributors informed of any such monitoring.

5 Manufacturers shall ensure that the packaging of the EU fertilising products which they have placed on the market bears a type number, batch number or other element allowing their identification or, where the EU fertilising products are supplied without packaging, that the required information is provided in a document accompanying each fertilising product.

6 Manufacturers shall indicate their name, registered trade name or registered trade mark and the postal address at which they can be contacted on the packaging of the EU fertilising product or, where the EU fertilising product is supplied without packaging, in a document accompanying the EU fertilising product. The postal address shall indicate a single point at which the manufacturer can be contacted. Such information shall be in a language easily understood by end-users and market surveillance authorities and shall be clear, understandable and legible.

7 Manufacturers shall ensure that EU fertilising products are accompanied by the information required under Annex III. Where an EU fertilising product is supplied in a package, the information shall appear on a label which is affixed to that package. Where the package is too small to contain all the information, the information that cannot be provided on the label shall be provided in a separate leaflet accompanying that package. Such a leaflet shall be regarded as part of the label. Where the EU fertilising product is supplied without packaging, all the information shall be provided in a leaflet. The label and the leaflet shall be accessible for inspection purposes when the EU fertilising product is made available on the market. The information shall be in a language which can be easily understood by end-users, as determined by the Member State concerned, and shall be clear, understandable and intelligible.

8 Manufacturers who consider or have reason to believe that an EU fertilising product which they have placed on the market is not in conformity with this Regulation shall immediately take the corrective measures necessary to bring that EU fertilising product into conformity, to withdraw it or to recall it, as appropriate. Furthermore, where manufacturers consider or have reason to believe that an EU fertilising product which they have placed on the market presents a risk to human, animal or plant health, to safety or to the environment, they shall immediately inform the competent national authorities of the Member States in which they made the EU fertilising product available on the market to that effect, giving details, in particular, of any non-compliance and of any corrective measures taken.

9 Manufacturers shall, further to a reasoned request from a competent national authority, provide it with all the information and documentation, in paper or electronic form, necessary to demonstrate the conformity of the EU fertilising product with this Regulation, in a language which can be easily understood by that authority. They shall cooperate with that authority, at its request, on any action taken to eliminate the risks posed by an EU fertilising product which they have placed on the market.

Status: Point in time view as at 05/06/2019.

Changes to legislation: There are currently no known outstanding effects for the Regulation (EU) 2019/1009 of the European Parliament and of the Council. (See end of Document for details)

Article 7 **U.K.**

Authorised representative

1 A manufacturer may, by a written mandate, appoint an authorised representative.

The obligations laid down in Article 6(1) and the obligation to draw up technical documentation referred to in Article 6(2) shall not form part of the authorised representative's mandate.

2 An authorised representative shall perform the tasks specified in the mandate received from the manufacturer. The mandate shall allow the authorised representative to do at least the following:

- a keep the EU declaration of conformity and the technical documentation at the disposal of national market surveillance authorities for 5 years after the EU fertilising product covered by those documents has been placed on the market;
- b further to a reasoned request from a competent national authority, provide that authority with all the information and documentation necessary to demonstrate the conformity of an EU fertilising product;
- c cooperate with the competent national authorities, at their request, on any action taken to eliminate the risks posed by EU fertilising products covered by the authorised representative's mandate.

Article 8 **U.K.**

Obligations of importers

1 Importers shall place only compliant EU fertilising products on the market.

2 Before placing an EU fertilising product on the market, importers shall ensure that the appropriate conformity assessment procedure referred to in Article 15 has been carried out by the manufacturer. They shall ensure that the manufacturer has drawn up the technical documentation, that the EU fertilising product is accompanied by the required documents, and that the manufacturer has complied with the requirements set out in Article 6(5) and (6).

Where an importer considers or has reason to believe that an EU fertilising product is not in conformity with this Regulation, the importer shall not place the EU fertilising product on the market until it has been brought into conformity. Furthermore, where the EU fertilising product presents a risk to human, animal or plant health, to safety or to the environment, the importer shall inform the manufacturer and the market surveillance authorities to that effect.

3 Importers shall indicate their name, registered trade name or registered trade mark and the postal address at which they can be contacted on the packaging of the EU fertilising product or, where the EU fertilising product is supplied without packaging, in a document accompanying the EU fertilising product. The contact details shall be in a language easily understood by end-users and market surveillance authorities.

4 Importers shall ensure that EU fertilising products are accompanied by the information required under Annex III. Where an EU fertilising product is supplied in a package, the information shall appear on a label which is affixed to that package. Where the package is too small to contain all the information, the information that cannot be provided on the label shall be

Status: Point in time view as at 05/06/2019.

Changes to legislation: There are currently no known outstanding effects for the Regulation (EU) 2019/1009 of the European Parliament and of the Council. (See end of Document for details)

provided in a separate leaflet accompanying that package. Such a leaflet shall be regarded as part of the label. Where the EU fertilising product is supplied without packaging, all the information shall be provided in a leaflet. The label and the leaflet shall be accessible for inspection purposes when the EU fertilising product is made available on the market. The information shall be in a language which can be easily understood by end-users, as determined by the Member State concerned.

5 Importers shall ensure that, while an EU fertilising product is under their responsibility, its storage or transport conditions do not jeopardise its compliance with the requirements set out in Annex I or III.

6 When deemed appropriate with regard to the performance of, or the risks presented by an EU fertilising product, importers shall carry out sample testing of such EU fertilising products made available on the market, investigate, and, if necessary, keep a register of complaints, of non-conforming EU fertilising products and recalls of such EU fertilising products, and shall keep distributors informed of any such monitoring.

7 Importers who consider or have reason to believe that an EU fertilising product which they have placed on the market is not in conformity with this Regulation shall immediately take the corrective measures necessary to bring that EU fertilising product into conformity, to withdraw it or to recall it, as appropriate. Furthermore, where importers consider or have reason to believe that an EU fertilising product which they have placed on the market presents a risk to human, animal or plant health, to safety or to the environment, they shall immediately inform the competent national authorities of the Member States in which they made the EU fertilising product available on the market to that effect, giving details, in particular, of any non-compliance and of any corrective measures taken.

8 Importers shall, for 5 years after the EU fertilising product has been placed on the market, keep a copy of the EU declaration of conformity at the disposal of the market surveillance authorities and ensure that the technical documentation can be made available to those authorities, upon request.

On request, importers shall make a copy of the EU declaration of conformity available to other economic operators.

9 Importers shall, further to a reasoned request from a competent national authority, provide it with all the information and documentation, in paper or electronic form, necessary to demonstrate the conformity of the EU fertilising product with this Regulation in a language which can be easily understood by that authority. They shall cooperate with that authority, at its request, on any action taken to eliminate the risks posed by an EU fertilising product which they have placed on the market.

Article 9 **U.K.**

Obligations of distributors

1 When making an EU fertilising product available on the market distributors shall act with due care in relation to the requirements of this Regulation.

2 Before making an EU fertilising product available on the market distributors shall verify that it is accompanied by the required documents, including the information referred to in Article 6(7) or Article 8(4) provided in the manner specified therein, in a language which can be easily understood by end-users in the Member State in which the EU fertilising product is to be made available on the market, and that the manufacturer and the importer have complied with the requirements set out in Article 6(5) and (6) and Article 8(3) respectively.

Status: Point in time view as at 05/06/2019.

Changes to legislation: There are currently no known outstanding effects for the Regulation (EU) 2019/1009 of the European Parliament and of the Council. (See end of Document for details)

Where a distributor considers or has reason to believe that an EU fertilising product is not in conformity with this Regulation, the distributor shall not make the EU fertilising product available on the market until it has been brought into conformity. Furthermore, where the EU fertilising product presents a risk to human, animal or plant health, to safety or to the environment, the distributor shall inform the manufacturer or the importer to that effect as well as the market surveillance authorities.

3 Distributors shall ensure that, while an EU fertilising product is under their responsibility, its storage or transport conditions do not jeopardise its compliance with the requirements set out in Annex I or III.

4 Distributors who consider or have reason to believe that an EU fertilising product which they have made available on the market is not in conformity with this Regulation shall make sure that the corrective measures necessary to bring that EU fertilising product into conformity, to withdraw it or to recall it, as appropriate, are taken. Furthermore, where distributors consider or have reason to believe that an EU fertilising product which they have made available on the market presents a risk to human, animal or plant health, to safety or to the environment, they shall immediately inform the competent national authorities of the Member States in which they made the EU fertilising product available on the market to that effect, giving details, in particular, of any non-compliance and of any corrective measures taken.

5 Distributors shall, further to a reasoned request from a competent national authority, provide it with all the information and documentation, in paper or electronic form, necessary to demonstrate the conformity of the EU fertilising product with this Regulation. They shall cooperate with that authority, at its request, on any action taken to eliminate the risks posed by EU fertilising products which they have made available on the market.

Article 10 **U.K.**

Cases in which obligations of manufacturers apply to importers and distributors

An importer or distributor shall be considered a manufacturer for the purposes of this Regulation, and shall be subject to the obligations of the manufacturer under Article 6, where that importer or distributor places an EU fertilising product on the market under his or her name or trademark or modifies an EU fertilising product already placed on the market in such a way that compliance with this Regulation may be affected.

Article 11 **U.K.**

Packaging and repackaging by importers and distributors

Where an importer or distributor packages or repackages an EU fertilising product and is not considered a manufacturer pursuant to Article 10, that importer or distributor shall:

- (a) ensure that the packaging bears his or her name, registered trade name or registered trade mark and postal address preceded by the words ‘packaged by’ or ‘repackaged by’; and
- (b) keep a specimen of the original information referred to in Article 6(7) or Article 8(4) at the disposal of the market surveillance authorities for 5 years after having made the EU fertilising product available on the market.

Status: Point in time view as at 05/06/2019.

Changes to legislation: There are currently no known outstanding effects for the Regulation (EU) 2019/1009 of the European Parliament and of the Council. (See end of Document for details)

Article 12 U.K.

Identification of economic operators

1 Economic operators shall, on request, identify the following to the market surveillance authorities:

- a any economic operator who has supplied them with an EU fertilising product;
- b any economic operator to whom they have supplied an EU fertilising product.

2 The economic operators shall be able to present the information referred to in the first paragraph for 5 years after they have been supplied with the EU fertilising product and for 5 years after they have supplied the EU fertilising product.

CHAPTER III U.K.

CONFORMITY OF EU FERTILISING PRODUCTS

Article 13 U.K.

Presumption of conformity

1 EU fertilising products which are in conformity with harmonised standards or parts thereof, the references of which have been published in the *Official Journal of the European Union*, shall be presumed to be in conformity with the requirements set out in Annexes I, II and III covered by those standards or parts thereof.

2 Tests for verifying the conformity of EU fertilising products with the requirements set out in Annexes I, II and III shall be performed in a reliable and reproducible manner. Tests which are in conformity with harmonised standards or parts thereof, the references of which have been published in the *Official Journal of the European Union*, shall be presumed to be reliable and reproducible to the extent that the tests are covered by those standards or parts thereof.

Article 14 U.K.

Common specifications

1 The Commission may adopt implementing acts laying down common specifications for the requirements set out in Annex I, II or III or tests referred to in Article 13(2) where:

- a those requirements or tests are not covered by harmonised standards or parts thereof, the references of which have been published in the *Official Journal of the European Union*;
- b the Commission observes undue delays in the adoption of requested harmonised standards; or
- c the Commission has decided in accordance with the procedure referred to in Article 11(5) of Regulation (EU) No 1025/2012 to maintain with restriction or to withdraw the references to the harmonised standards or parts thereof by which those requirements or tests are covered.

Those implementing acts shall be adopted in accordance with the examination procedure referred to in Article 45(3).

Status: Point in time view as at 05/06/2019.

Changes to legislation: There are currently no known outstanding effects for the Regulation (EU) 2019/1009 of the European Parliament and of the Council. (See end of Document for details)

2 EU fertilising products which are in conformity with common specifications or parts thereof shall be presumed to be in conformity with the requirements set out in Annexes I, II and III covered by those common specifications or parts thereof.

3 Tests for verifying the conformity of EU fertilising products with the requirements set out in Annexes I, II and III which are in conformity with common specifications or parts thereof shall be presumed to be reliable and reproducible to the extent that the tests are covered by those common specifications or parts thereof.

Article 15 U.K.

Conformity assessment procedures

1 Conformity assessment of an EU fertilising product with the requirements laid down in this Regulation shall be carried out under the applicable conformity assessment procedure in accordance with Annex IV.

2 Records and correspondence relating to conformity assessment procedures shall be drawn up in the official language or languages of the Member State where the notified body carrying out the conformity assessment procedures is established, or in a language accepted by that body.

Article 16 U.K.

EU declaration of conformity

1 The EU declaration of conformity shall state that the fulfilment of the requirements laid down in this Regulation has been demonstrated.

2 The EU declaration of conformity shall have the model structure set out in Annex V, shall contain the elements specified in the relevant modules set out in Annex IV and shall be continuously updated. It shall be translated into the language or languages required by the Member State in which the EU fertilising product is placed or made available on the market.

3 Where an EU fertilising product is subject to more than one Union act requiring an EU declaration of conformity, a single EU declaration of conformity shall be drawn up in respect of all such Union acts. That declaration shall state the Union acts concerned and their publication references. It may be a dossier made up of relevant individual EU declarations of conformity.

4 By drawing up the EU declaration of conformity, the manufacturer shall assume responsibility for the compliance of the EU fertilising product with the requirements laid down in this Regulation.

Article 17 U.K.

General principles of CE marking

The CE marking shall be subject to the general principles set out in Article 30 of Regulation (EC) No 765/2008.

Status: Point in time view as at 05/06/2019.

Changes to legislation: There are currently no known outstanding effects for the Regulation (EU) 2019/1009 of the European Parliament and of the Council. (See end of Document for details)

Article 18 **U.K.**

Rules and conditions for affixing the CE marking

1 The CE marking shall be affixed visibly, legibly and indelibly to the packaging of the EU fertilising product or, where the EU fertilising product is supplied without packaging, to a document accompanying the EU fertilising product.

2 The CE marking shall be affixed before the EU fertilising product is placed on the market.

3 The CE marking shall be followed by the identification number of the notified body, where required under Annex IV.

The identification number of the notified body shall be affixed by the body itself or, under its instructions, by the manufacturer or his or her authorised representative.

4 Member States shall build upon existing mechanisms to ensure correct application of the regime governing the CE marking and shall take appropriate action in the event of improper use of that marking.

Article 19 **U.K.**

End-of-waste status

This Regulation lays down criteria in accordance with which material that constitutes waste, as defined in Directive 2008/98/EC, can cease to be waste, if it is contained in a compliant EU fertilising product. In such cases, the recovery operation under this Regulation shall be performed before the material ceases to be waste, and the material shall be considered to comply with the conditions laid down in Article 6 of that Directive and therefore to have ceased to be waste from the moment that the EU declaration of conformity was drawn up.

CHAPTER IV **U.K.**

NOTIFICATION OF CONFORMITY ASSESSMENT BODIES

Article 20 **U.K.**

Notification

Member States shall notify the Commission and the other Member States of bodies authorised to carry out third-party conformity assessment tasks under this Regulation.

Status: Point in time view as at 05/06/2019.

Changes to legislation: There are currently no known outstanding effects for the Regulation (EU) 2019/1009 of the European Parliament and of the Council. (See end of Document for details)

Article 21 **U.K.**

Notifying authorities

1 Member States shall designate a notifying authority that shall be responsible for setting up and carrying out the necessary procedures for the assessment and notification of conformity assessment bodies and the monitoring of notified bodies, including compliance with Article 26.

2 Member States may decide that the assessment and monitoring referred to in paragraph 1 of this Article shall be carried out by a national accreditation body within the meaning of and in accordance with Regulation (EC) No 765/2008.

3 Where the notifying authority delegates or otherwise entrusts the assessment, notification or monitoring referred to in paragraph 1 of this Article to a body which is not a governmental entity, that body shall be a legal entity and shall comply *mutatis mutandis* with the requirements laid down in Article 22. In addition that body shall have arrangements to cover liabilities arising out of its activities.

4 The notifying authority shall take full responsibility for the tasks performed by the body referred to in paragraph 3.

Article 22 **U.K.**

Requirements relating to notifying authorities

1 A notifying authority shall be established in such a way that no conflict of interest with conformity assessment bodies occurs.

2 A notifying authority shall be organised and operated so as to safeguard the objectivity and impartiality of its activities.

3 A notifying authority shall be organised in such a way that each decision relating to notification of a conformity assessment body is taken by competent persons different from those who carried out the assessment.

4 A notifying authority shall not offer or provide any activities that conformity assessment bodies perform or consultancy services on a commercial or competitive basis.

5 A notifying authority shall safeguard the confidentiality of the information it obtains.

6 A notifying authority shall have a sufficient number of competent personnel at its disposal for the proper performance of its tasks.

Article 23 **U.K.**

Information obligation on notifying authorities

Member States shall inform the Commission of their procedures for the assessment and notification of conformity assessment bodies and the monitoring of notified bodies, and of any changes thereto.

The Commission shall make that information publicly available.

Status: Point in time view as at 05/06/2019.

Changes to legislation: There are currently no known outstanding effects for the Regulation (EU) 2019/1009 of the European Parliament and of the Council. (See end of Document for details)

Article 24 **U.K.**

Requirements relating to notified bodies

1 For the purposes of notification, a conformity assessment body shall meet the requirements laid down in paragraphs 2 to 11.

2 A conformity assessment body shall be established under the national law of a Member State and have legal personality.

3 A conformity assessment body shall be a third-party body independent of the organisation or the EU fertilising products it assesses.

4 A conformity assessment body, its top level management and the personnel responsible for carrying out the conformity assessment tasks shall not be the designer, manufacturer, supplier, purchaser, owner or user of fertilising products nor the representative of any of those parties. This shall not preclude the use of fertilising products that are necessary for the operations of the conformity assessment body or the use of fertilising products for personal purposes.

A conformity assessment body, its top level management and the personnel responsible for carrying out the conformity assessment tasks shall not be directly involved in the design, manufacture, marketing or use of fertilising products or represent the parties engaged in those activities. They shall not engage in any activity that may conflict with their independence of judgement or integrity in relation to conformity assessment activities for which they are notified. This shall in particular apply to consultancy services.

Conformity assessment bodies shall ensure that the activities of their subsidiaries or subcontractors do not affect the confidentiality, objectivity or impartiality of their conformity assessment activities.

5 Conformity assessment bodies and their personnel shall carry out the conformity assessment activities with the highest degree of professional integrity and the requisite technical competence in the specific field and shall be free from all pressures and inducements, particularly financial, which might influence their judgement or the results of their conformity assessment activities, especially as regards persons or groups of persons with an interest in the results of those activities.

6 A conformity assessment body shall be capable of carrying out all the conformity assessment tasks assigned to it by Annex IV and in relation to which it has been notified, whether those tasks are carried out by the conformity assessment body itself or on its behalf and under its responsibility.

At all times and for each conformity assessment procedure and each kind or category of EU fertilising products in relation to which it has been notified, a conformity assessment body shall have at its disposal the necessary:

- a personnel with technical knowledge and sufficient and appropriate experience to perform the conformity assessment tasks;
- b descriptions of procedures in accordance with which conformity assessment is carried out, ensuring the transparency and the ability of reproduction of those procedures. It shall have appropriate policies and procedures in place that distinguish between tasks it carries out as a notified body and other activities;

Status: Point in time view as at 05/06/2019.

Changes to legislation: There are currently no known outstanding effects for the Regulation (EU) 2019/1009 of the European Parliament and of the Council. (See end of Document for details)

- c procedures for the performance of activities which take due account of the size of an undertaking, the sector in which it operates, its structure, the degree of complexity of the product technology in question and the mass or serial nature of the production process.

A conformity assessment body shall have the means necessary to perform the technical and administrative tasks connected with the conformity assessment activities in an appropriate manner and shall have access to all necessary equipment or facilities.

7 The personnel responsible for carrying out the conformity assessment tasks shall have the following:

- a sound technical and vocational training covering all the conformity assessment activities in relation to which the conformity assessment body has been notified;
- b satisfactory knowledge of the requirements of the assessments they carry out and adequate authority to carry out those assessments;
- c appropriate knowledge and understanding of the requirements set out in Annexes I, II and III, of the applicable harmonised standards referred to in Article 13 and common specifications referred to in Article 14 and of the relevant provisions of Union harmonisation legislation and of national legislation;
- d the ability to draw up certificates, records and reports demonstrating that assessments have been carried out.

8 The impartiality of the conformity assessment bodies, their top level management and of the personnel responsible for carrying out the conformity assessment tasks shall be guaranteed.

The remuneration of the top level management and personnel responsible for carrying out the conformity assessment tasks of a conformity assessment body shall not depend on the number of assessments carried out or on the results of those assessments.

9 Conformity assessment bodies shall take out liability insurance unless liability is assumed by the State in accordance with national law, or the Member State itself is directly responsible for the conformity assessment.

10 The personnel of a conformity assessment body shall observe professional secrecy with regard to all information obtained in carrying out their tasks under Annex IV, except in relation to the competent authorities of the Member State in which its activities are carried out. Proprietary rights shall be protected.

11 Conformity assessment bodies shall participate in, or ensure that their personnel responsible for carrying out the conformity assessment tasks are informed of, the relevant standardisation activities and the activities of the notified body coordination group established under Article 36 and shall apply as general guidance the administrative decisions and documents produced as a result of the work of that group.

Article 25 **U.K.**

Presumption of conformity of notified bodies

Where a conformity assessment body demonstrates its conformity with the criteria laid down in the relevant harmonised standards or parts thereof the references of which have been published in the *Official Journal of the European Union* it shall be presumed to comply with the requirements set out in Article 24 in so far as the applicable harmonised standards cover those requirements.

Status: Point in time view as at 05/06/2019.

Changes to legislation: There are currently no known outstanding effects for the Regulation (EU) 2019/1009 of the European Parliament and of the Council. (See end of Document for details)

Article 26 **U.K.**

Subsidiaries of and subcontracting by notified bodies

1 Where a notified body subcontracts specific tasks connected with conformity assessment or has recourse to a subsidiary, it shall ensure that the subcontractor or the subsidiary meets the requirements set out in Article 24 and shall inform the notifying authority accordingly.

2 Notified bodies shall take full responsibility for the tasks performed by subcontractors or subsidiaries wherever these are established.

3 Activities may be subcontracted or carried out by a subsidiary only with the agreement of the client.

4 Notified bodies shall keep at the disposal of the notifying authority the relevant documents concerning the assessment of the qualifications of the subcontractor or the subsidiary and the work carried out by them under Annex IV.

Article 27 **U.K.**

Application for notification

1 A conformity assessment body shall submit an application for notification to the notifying authority of the Member State in which it is established.

2 The application for notification shall be accompanied by a description of the conformity assessment activities, the conformity assessment module or modules and the EU fertilising product or products for which that body claims to be competent, as well as by an accreditation certificate issued by a national accreditation body attesting that the conformity assessment body fulfils the requirements laid down in Article 24.

Article 28 **U.K.**

Notification procedure

1 Notifying authorities may notify only conformity assessment bodies which have satisfied the requirements laid down in Article 24.

2 They shall notify the Commission and the other Member States using the electronic notification tool developed and managed by the Commission.

3 The notification shall include full details of the conformity assessment activities, the conformity assessment module or modules and EU fertilising product or products concerned and the accreditation certificate referred to in Article 27(2).

4 The body concerned may perform the activities of a notified body only where no objections are raised by the Commission or the other Member States within two weeks of a notification.

Only such a body shall be considered a notified body for the purposes of this Regulation.

5 The notifying authority shall notify the Commission and the other Member States of any subsequent relevant changes to the notification.

Status: Point in time view as at 05/06/2019.

Changes to legislation: There are currently no known outstanding effects for the Regulation (EU) 2019/1009 of the European Parliament and of the Council. (See end of Document for details)

Article 29 **U.K.**

Identification numbers and lists of notified bodies

1 The Commission shall assign an identification number to a notified body.

It shall assign a single such number even where the body is notified under several Union acts.

2 The Commission shall make publicly available the list of the bodies notified under this Regulation, including the identification numbers that have been assigned to them and the activities for which they have been notified.

The Commission shall ensure that the list is kept up to date.

Article 30 **U.K.**

Changes to notifications

1 Where a notifying authority has ascertained or has been informed that a notified body no longer meets the requirements laid down in Article 24 or that it is failing to fulfil its obligations, the notifying authority shall restrict, suspend or withdraw notification as appropriate, depending on the seriousness of the failure to meet those requirements or fulfil those obligations. It shall immediately inform the Commission and the other Member States accordingly.

2 In the event of restriction, suspension or withdrawal of notification, or where the notified body has ceased its activity, the notifying Member State shall take appropriate steps to ensure that the files of that body are either processed by another notified body or kept available for the responsible notifying and market surveillance authorities at their request.

Article 31 **U.K.**

Challenge of the competence of notified bodies

1 The Commission shall investigate all cases where it doubts, or doubt is brought to its attention regarding, the competence of a notified body or the continued fulfilment by a notified body of the requirements and responsibilities to which it is subject.

2 The notifying Member State shall provide the Commission, on request, with all information relating to the basis for the notification or the maintenance of the competence of the notified body concerned.

3 The Commission shall ensure that all sensitive information obtained in the course of its investigations is treated confidentially.

4 Where the Commission ascertains that a notified body does not meet or no longer meets the requirements for its notification, it shall adopt an implementing act requiring the notifying Member State to take the necessary corrective measures, including withdrawal of notification if necessary.

That implementing act shall be adopted in accordance with the advisory procedure referred to in Article 45(2).

Status: Point in time view as at 05/06/2019.

Changes to legislation: There are currently no known outstanding effects for the Regulation (EU) 2019/1009 of the European Parliament and of the Council. (See end of Document for details)

Article 32 **U.K.**

Operational obligations of notified bodies

1 Notified bodies shall carry out conformity assessments in accordance with the conformity assessment procedures provided for in Annex IV.

2 Conformity assessments shall be carried out in a proportionate manner, avoiding unnecessary burdens for economic operators. Notified bodies shall perform their activities taking due account of the size of an undertaking, the sector in which it operates, its structure, the degree of complexity of the product technology in question and the mass or serial nature of the production process.

In so doing they shall nevertheless respect the degree of rigour and the level of protection required for the compliance of the EU fertilising product with this Regulation.

3 Where a notified body finds that the requirements set out in Annex I, II or III, or corresponding harmonised standards, common specifications referred to in Article 14 or other technical specifications, have not been met by a manufacturer, it shall require that manufacturer to take appropriate corrective measures and shall not issue a certificate or approval decision.

4 Where, in the course of the monitoring of conformity following the issue of a certificate or an approval decision, a notified body finds that an EU fertilising product no longer complies, it shall require the manufacturer to take appropriate corrective measures and shall suspend or withdraw the certificate or the approval decision, if necessary.

5 Where corrective measures are not taken or do not have the required effect, the notified body shall restrict, suspend or withdraw any certificates or approval decisions, as appropriate.

Article 33 **U.K.**

Appeal against decisions of notified bodies

Member States shall ensure that an appeal procedure against decisions of the notified bodies is available.

Article 34 **U.K.**

Information obligation on notified bodies

1 Notified bodies shall inform the notifying authority of the following:

- a any refusal, restriction, suspension or withdrawal of a certificate or approval decision;
- b any circumstances, affecting the scope of or conditions for notification;
- c any request for information which they have received from market surveillance authorities regarding conformity assessment activities;
- d on request, conformity assessment activities performed within the scope of their notification and any other activity performed, including cross-border activities and subcontracting.

2 Notified bodies shall provide the other bodies notified under this Regulation carrying out similar conformity assessment activities covering the same EU fertilising products with

Status: Point in time view as at 05/06/2019.

Changes to legislation: There are currently no known outstanding effects for the Regulation (EU) 2019/1009 of the European Parliament and of the Council. (See end of Document for details)

relevant information on issues relating to negative and, on request, positive conformity assessment results.

Article 35 **U.K.**

Exchange of experience

The Commission shall provide for the organisation of exchange of experience between the Member States' national authorities responsible for notification policy.

Article 36 **U.K.**

Coordination of notified bodies

The Commission shall ensure that appropriate coordination and cooperation between bodies notified under this Regulation are put in place and properly operated in the form of a sectoral group of notified bodies.

Notified bodies shall participate in the work of that group, directly or by means of designated representatives.

CHAPTER V **U.K.**

UNION MARKET SURVEILLANCE, CONTROL OF EU FERTILISING PRODUCTS ENTERING THE UNION MARKET AND UNION SAFEGUARD PROCEDURE

Article 37 **U.K.**

Union market surveillance and control of EU fertilising products entering the Union market

Articles 16 to 29 of Regulation (EC) No 765/2008 shall apply to EU fertilising products.

Article 38 **U.K.**

Procedure at national level for dealing with EU fertilising products presenting a risk

1 Where the market surveillance authorities of one Member State have sufficient reason to believe that an EU fertilising product presents a risk to human, animal or plant health, to safety or to the environment, they shall carry out an evaluation in relation to the EU fertilising product concerned covering all relevant requirements laid down in this Regulation. The relevant economic operators shall cooperate as necessary with the market surveillance authorities for that purpose.

Where, in the course of the evaluation referred to in the first subparagraph, the market surveillance authorities find that the EU fertilising product does not comply with the requirements laid down in this Regulation, they shall without delay require the relevant economic operator to take all appropriate corrective action, within a reasonable period prescribed by the market surveillance authorities and commensurate with the nature of

Status: Point in time view as at 05/06/2019.

Changes to legislation: There are currently no known outstanding effects for the Regulation (EU) 2019/1009 of the European Parliament and of the Council. (See end of Document for details)

the risk, to bring the EU fertilising product into compliance with those requirements, to withdraw the EU fertilising product from the market or to recall it.

The market surveillance authorities shall inform the relevant notified body accordingly.

Article 21 of Regulation (EC) No 765/2008 shall apply to the measures referred to in the second subparagraph of this paragraph.

2 Where the market surveillance authorities consider that non-compliance is not restricted to their national territory, they shall inform the Commission and the other Member States of the results of the evaluation and of the actions which they have required the economic operator to take.

3 The economic operator shall ensure that all appropriate corrective action is taken in respect of all the EU fertilising products concerned that the economic operator has made available on the market throughout the Union.

4 Where the relevant economic operator does not take adequate corrective action within the period referred to in the second subparagraph of paragraph 1, the market surveillance authorities shall take all appropriate provisional measures to prohibit or restrict the EU fertilising product being made available on their national market, to withdraw the EU fertilising product from that market or to recall it.

The market surveillance authorities shall inform the Commission and the other Member States, without delay, of those measures.

5 The information referred to in the second subparagraph of paragraph 4 shall include all available details, in particular the data necessary for the identification of the non-compliant EU fertilising product, the origin of that EU fertilising product, the nature of the non-compliance alleged and the risk involved, the nature and duration of the national measures taken and the arguments put forward by the relevant economic operator. In particular, the market surveillance authorities shall indicate whether the non-compliance is due to any of the following:

- a failure of the EU fertilising product to meet the requirements set out in Annex I, II or III;
- b shortcomings in the harmonised standards referred to in Article 13;
- c shortcomings in the common specifications referred to in Article 14.

6 Member States other than the Member State initiating the procedure under this Article shall without delay inform the Commission and the other Member States of any measures adopted and of any additional information at their disposal relating to the non-compliance of the EU fertilising product concerned, and, in the event of disagreement with the adopted national measure, of their objections.

7 Where, within three months of receipt of the information referred to in the second subparagraph of paragraph 4, no objection has been raised by either a Member State or the Commission in respect of a provisional measure taken by a Member State, that measure shall be deemed justified.

8 Member States shall ensure that appropriate restrictive measures, such as withdrawal of the EU fertilising product from the market, are taken without delay in respect of the EU fertilising product concerned.

9 Obligations of the market surveillance authorities under this Article shall be without prejudice to the possibility for Member States to regulate fertilising products which are not EU fertilising products.

Status: Point in time view as at 05/06/2019.

Changes to legislation: There are currently no known outstanding effects for the Regulation (EU) 2019/1009 of the European Parliament and of the Council. (See end of Document for details)

Article 39 **U.K.**

Union safeguard procedure

1 Where, on completion of the procedure set out in Article 38(3) and (4), objections are raised against a measure taken by a Member State, or where the Commission considers a national measure to be contrary to Union law, the Commission shall without delay enter into consultation with the Member States and the relevant economic operator or operators and shall evaluate the national measure. On the basis of the results of that evaluation, the Commission shall adopt an implementing act in the form of a decision determining whether the national measure is justified or not.

If the national measure is considered justified, the decision shall order all Member States to take the necessary measures to ensure that the non-compliant EU fertilising product is withdrawn from their market, and to inform the Commission accordingly.

If the national measure is considered unjustified, the decision shall order the Member State concerned to withdraw that measure.

The Commission shall address its decision to all Member States and shall immediately communicate it to them and the relevant economic operator or operators.

2 Where the national measure is considered justified and the non-compliance of the EU fertilising product is attributed to shortcomings in the harmonised standards referred to in point (b) of Article 38(5) of this Regulation, the Commission shall apply the procedure provided for in Article 11 of Regulation (EU) No 1025/2012.

3 Where the national measure is considered justified and the non-compliance of the EU fertilising product is attributed to shortcomings in the common specifications referred to in point (c) of Article 38(5), the Commission shall, without delay, adopt implementing acts amending or repealing the common specifications concerned.

Those implementing acts shall be adopted in accordance with the examination procedure referred to in Article 45(3).

Article 40 **U.K.**

Compliant EU fertilising products which present a risk

1 Where, having carried out an evaluation under Article 38(1), a Member State finds that although an EU fertilising product is in compliance with this Regulation it presents a risk to human, animal or plant health, to safety or to the environment, it shall without delay require the relevant economic operator to take all appropriate measures, within a reasonable period prescribed by the market surveillance authority and commensurate with the nature of the risk, to ensure that the EU fertilising product concerned, when made available on the market, no longer presents that risk, to withdraw the EU fertilising product from the market or to recall it.

2 The economic operator shall ensure that corrective action is taken in respect of all the EU fertilising products concerned that the economic operator has made available on the market throughout the Union.

3 The Member State shall immediately inform the Commission and the other Member States. That information shall include all available details, in particular the data

Status: Point in time view as at 05/06/2019.

Changes to legislation: There are currently no known outstanding effects for the Regulation (EU) 2019/1009 of the European Parliament and of the Council. (See end of Document for details)

necessary for the identification of the EU fertilising product concerned, the origin and the supply chain of that EU fertilising product, the nature of the risk involved and the nature and duration of the national measures taken.

4 The Commission shall without delay enter into consultation with the Member States and the relevant economic operator or operators and shall evaluate the national measures taken. On the basis of the results of that evaluation, the Commission shall adopt an implementing act in the form of a decision determining whether the national measure is justified or not, and where necessary, ordering appropriate measures.

Those implementing acts shall be adopted in accordance with the examination procedure referred to in Article 45(3).

On duly justified imperative grounds of urgency relating to the protection of human, animal or plant health, safety or the environment, the Commission shall adopt immediately applicable implementing acts in accordance with the procedure referred to in Article 45(4).

5 The Commission shall address its decision to all Member States and shall immediately communicate it to them and the relevant economic operator or operators.

Article 41 **U.K.**

Formal non-compliance

1 Without prejudice to Article 38, where a Member State makes one of the following findings with regard to an EU fertilising product, it shall require the relevant economic operator to put an end to the non-compliance concerned:

- a the CE marking has been affixed in violation of Article 30 of Regulation (EC) No 765/2008 or of Article 18 of this Regulation;
- b the identification number of the notified body has been affixed in violation of Article 18 or has not been affixed, where required by Article 18;
- c the EU declaration of conformity has not been drawn up or has not been drawn up correctly;
- d the technical documentation is either not available or not complete;
- e the information referred to in Article 6(6) or Article 8(3) is absent, false or incomplete;
- f any other administrative requirement provided for in Article 6 or Article 8 is not fulfilled.

2 Where the non-compliance referred to in paragraph 1 persists, the Member State concerned shall take all appropriate measures to restrict or prohibit the EU fertilising product being made available on the market or ensure that it is recalled or withdrawn from the market.

Obligations of Member States in this respect shall be without prejudice to the possibility for them to regulate fertilising products which are not EU fertilising products.

CHAPTER VI **U.K.****DELEGATED POWERS AND COMMITTEE PROCEDURE***Article 42* **U.K.****Amendments of Annexes**

1 The Commission is empowered to adopt delegated acts in accordance with Article 44 amending Annex I, with the exception of cadmium limit values and the definitions, or other elements relating to the scope, of product function categories, and amending Annexes II, III and IV, for the purposes of adapting those Annexes to technical progress and of facilitating internal market access and free movement for EU fertilising products:

- a which have the potential to be the subject of significant trade on the internal market, and
- b for which there is scientific evidence that they:
 - (i) do not present a risk to human, animal or plant health, to safety or to the environment, and
 - (ii) ensure agronomic efficiency.

When adopting delegated acts which introduce new contaminant limit values in Annex I, the Commission shall take into account scientific opinions of the European Food Safety Authority, the European Chemicals Agency or the Commission's Joint Research Centre, as relevant.

Where the Commission adopts delegated acts in order to add or review component material categories so as to include materials that can be considered to be recovered waste or by-products within the meaning of Directive 2008/98/EC, those delegated acts shall explicitly exclude such materials from component material categories 1 and 11 of Annex II to this Regulation.

When adopting delegated acts under this paragraph, the Commission shall prioritise in particular animal by-products, by-products within the meaning of Directive 2008/98/EC, and recovered waste, in particular from the agricultural sector and the agro-food industry, as well as materials and products already lawfully placed on the market in one or more Member States.

2 Without undue delay after 15 July 2019, the Commission shall assess struvite, biochar and ash-based products. If that assessment concludes that the criteria in point (b) of paragraph 1 are fulfilled, the Commission shall adopt delegated acts pursuant to paragraph 1 to include those materials in Annex II.

3 The Commission may only adopt delegated acts pursuant to paragraph 1 amending Annex II to this Regulation to include in the component material categories materials that cease to be waste following a recovery operation if recovery rules in that Annex, adopted no later than the inclusion, ensure that the materials comply with the conditions laid down in Article 6 of Directive 2008/98/EC.

4 The Commission may only adopt delegated acts pursuant to paragraph 1 amending Annex II to add new micro-organisms or strains of micro-organisms, or additional processing methods to the component material category for such organisms after having verified which strains of the additional micro-organism fulfil the criteria in point (b) of paragraph 1, on the basis of the following data:

Status: Point in time view as at 05/06/2019.

Changes to legislation: There are currently no known outstanding effects for the Regulation (EU) 2019/1009 of the European Parliament and of the Council. (See end of Document for details)

- a name of the micro-organism;
- b taxonomic classification of the micro-organism: genus, species, strain and procurement method;
- c scientific literature reporting about safe production, conservation and use of the micro-organism;
- d taxonomic relation to micro-organism species fulfilling the requirements for a Qualified Presumption of Safety as established by the European Food Safety Authority;
- e information on the production process, including, where relevant, processing methods such as spray drying, fluid-bed drying, static drying, centrifugation, deactivation by heat, filtration and grinding;
- f information on the identity and residue levels of residual intermediates, toxins or microbial metabolites in the component material; and
- g natural occurrence, survival and mobility in the environment.

5 The Commission may only adopt delegated acts pursuant to paragraph 1 amending Annex II to this Regulation to add derived products within the meaning of Regulation (EC) No 1069/2009 in the component material categories where an end point in the manufacturing chain has been determined in accordance with Article 5(2) of that Regulation.

The Commission shall assess such derived products with respect to relevant aspects not taken into account for the purpose of determining an end point in the manufacturing chain in accordance with Regulation (EC) No 1069/2009. If that assessment concludes that the criteria in point (b) of paragraph 1 of this Article are fulfilled, the Commission shall adopt delegated acts pursuant to paragraph 1 of this Article to include those materials in the table in component material category 10 in Part II of Annex II to this Regulation without undue delay whenever such an end point is determined.

6 By 16 July 2024, the Commission shall assess biodegradability criteria for polymers referred to in point 2 of component material category 9 in Part II of Annex II and test methods to verify compliance with those criteria and, where appropriate, shall adopt delegated acts pursuant to paragraph 1 which lay down those criteria.

Such criteria shall ensure that:

- a the polymer is capable of undergoing physical and biological decomposition in natural soil conditions and aquatic environments across the Union, so that it ultimately decomposes only into carbon dioxide, biomass and water;
- b the polymer has at least 90 % of the organic carbon converted into carbon dioxide in a maximum period of 48 months after the end of the claimed functionality period of the EU fertilising product indicated on the label, and as compared to an appropriate standard in the biodegradation test; and
- c the use of polymers does not lead to accumulation of plastics in the environment.

7 By 16 July 2022, the Commission shall adopt delegated acts in accordance with Article 44 supplementing point 3 of component material category 11 in Part II of Annex II to this Regulation by laying down criteria on agronomic efficiency and safety for the use of by-products within the meaning of Directive 2008/98/EC in EU fertilising products. Such criteria shall reflect present product manufacturing practices, technological developments and the latest scientific evidence.

8 The Commission is empowered to adopt delegated acts in accordance with Article 44 amending Annex I, with the exception of cadmium limit values, and Annexes II, III and IV in the light of new scientific evidence. The Commission shall use this empowerment where, based on a risk assessment, an amendment proves necessary to ensure that any EU fertilising product

Status: Point in time view as at 05/06/2019.

Changes to legislation: There are currently no known outstanding effects for the Regulation (EU) 2019/1009 of the European Parliament and of the Council. (See end of Document for details)

complying with the requirements of this Regulation does not, under normal conditions of use, present a risk to human, animal, or plant health, to safety or to the environment.

Article 43 **U.K.**

Separate delegated acts for separate component material categories

When exercising its power to adopt delegated acts pursuant to Article 42, the Commission shall adopt a separate delegated act in respect of each component material category in Annex II. Those delegated acts shall include any amendments to Annexes I, III and IV which are necessary as a consequence of amendments to Annex II.

Article 44 **U.K.**

Exercise of the delegation

1 The power to adopt delegated acts is conferred on the Commission subject to the conditions laid down in this Article.

2 The power to adopt delegated acts referred to in Article 42 shall be conferred on the Commission for a period of five years from 15 July 2019. The Commission shall draw up a report in respect of the delegation of power not later than nine months before the end of the five-year period. The delegation of power shall be tacitly extended for periods of an identical duration, unless the European Parliament or the Council opposes such extension not later than three months before the end of each period.

3 The delegation of power referred to in Article 42 may be revoked at any time by the European Parliament or by the Council. A decision to revoke shall put an end to the delegation of the power specified in that decision. It shall take effect the day following the publication of the decision in the *Official Journal of the European Union* or at a later date specified therein. It shall not affect the validity of any delegated acts already in force.

4 Before adopting a delegated act, the Commission shall consult experts designated by each Member State in accordance with the principles laid down in the Interinstitutional Agreement of 13 April 2016 on Better Law-Making.

5 As soon as it adopts a delegated act, the Commission shall notify it simultaneously to the European Parliament and to the Council.

6 A delegated act adopted pursuant to Article 42 shall enter into force only if no objection has been expressed either by the European Parliament or the Council within a period of three months of notification of that act to the European Parliament and the Council or if, before the expiry of that period, the European Parliament and the Council have both informed the Commission that they will not object. That period shall be extended by three months at the initiative of the European Parliament or of the Council.

Article 45 **U.K.**

Committee procedure

1 The Commission shall be assisted by the Committee on fertilising products. That committee shall be a committee within the meaning of Regulation (EU) No 182/2011.

Status: Point in time view as at 05/06/2019.

Changes to legislation: There are currently no known outstanding effects for the Regulation (EU) 2019/1009 of the European Parliament and of the Council. (See end of Document for details)

2 Where reference is made to this paragraph, Article 4 of Regulation (EU) No 182/2011 shall apply.

3 Where reference is made to this paragraph, Article 5 of Regulation (EU) No 182/2011 shall apply.

4 Where reference is made to this paragraph, Article 8 of Regulation (EU) No 182/2011, in conjunction with Article 5 thereof, shall apply.

CHAPTER VII **U.K.**

AMENDMENTS

Article 46 **U.K.**

Amendments to Regulation (EC) No 1069/2009

Regulation (EC) No 1069/2009 is amended as follows:

(1) in Article 5, paragraphs 2 and 3 are replaced by the following:

2. For derived products referred to in Articles 32, 35 and 36 which no longer pose any significant risk to public or animal health, an end point in the manufacturing chain may be determined, beyond which they are no longer subject to the requirements of this Regulation.

Those derived products may subsequently be placed on the market without restrictions under this Regulation and shall no longer be subject to official controls in accordance with this Regulation.

The Commission is empowered to adopt delegated acts in accordance with Article 51a supplementing this Regulation by determining an end point in the manufacturing chain, beyond which derived products referred to in this paragraph are no longer subject to the requirements of this Regulation.

3 In the event of risks to public or animal health, Articles 53 and 54 of Regulation (EC) No 178/2002 concerning emergency health measures shall apply *mutatis mutandis* to the derived products referred to in Articles 32, 33 and 36 of this Regulation.

4 Within six months after 15 July 2019, the Commission shall initiate a first assessment of derived products referred to in Article 32 that are already widely used in the Union as organic fertilisers and soil improvers. This assessment shall cover at least the following products: meat meal, bone meal, meat-and-bone meal, hydrolysed proteins of Category 3 materials, processed manure, compost, biogas digestion residues, feather meal, glycerine and other products of Category 2 or 3 materials derived from the production of biodiesel and renewable fuels, as well as petfood, feed and dog chews that have been refused for commercial reasons or technical failures, and derived products from blood of animals, hides and skins, hoofs and horns, guano of bats and birds, wool and hair, feather and downs, and pig bristles. Where the assessment concludes that those derived products no longer pose any significant risk to public or animal health, the Commission shall determine an end point in the manufacturing chain pursuant to paragraph 2 of this Article without undue delay and in any case no later than six months after the assessment is finalised.;

Status: Point in time view as at 05/06/2019.

Changes to legislation: There are currently no known outstanding effects for the Regulation (EU) 2019/1009 of the European Parliament and of the Council. (See end of Document for details)

- (2) the following Article is inserted:

Article 51a

Exercise of the delegation

- 1 The power to adopt delegated acts is conferred on the Commission subject to the conditions laid down in this Article.
- 2 The power to adopt delegated acts referred to in Article 5(2) shall be conferred on the Commission for a period of five years from 15 July 2019. The Commission shall draw up a report in respect of the delegation of power not later than nine months before the end of the five-year period. The delegation of power shall be tacitly extended for periods of an identical duration, unless the European Parliament or the Council opposes such extension not later than three months before the end of each period.
- 3 The delegation of power referred to in Article 5(2) may be revoked at any time by the European Parliament or by the Council. A decision to revoke shall put an end to the delegation of the power specified in that decision. It shall take effect the day following the publication of the decision in the *Official Journal of the European Union* or at a later date specified therein. It shall not affect the validity of any delegated acts already in force.
- 4 Before adopting a delegated act, the Commission shall consult experts designated by each Member State in accordance with the principles laid down in the Interinstitutional Agreement of 13 April 2016 on Better Law-Making⁽²⁹⁾.
- 5 As soon as it adopts a delegated act, the Commission shall notify it simultaneously to the European Parliament and to the Council.
- 6 A delegated act adopted pursuant to Article 5(2) shall enter into force only if no objection has been expressed either by the European Parliament or by the Council within a period of two months of notification of that act to the European Parliament and the Council or if, before the expiry of that period, the European Parliament and the Council have both informed the Commission that they will not object. That period shall be extended by two months at the initiative of the European Parliament or of the Council.

Article 47 **U.K.**

Amendments to Regulation (EC) No 1107/2009

Regulation (EC) No 1107/2009 is amended as follows:

- (1) in Article 2(1), point (b) is replaced by the following:
- (b) influencing the life processes of plants, such as substances influencing their growth, other than as a nutrient or a plant biostimulant;;
- (2) in Article 3, the following point is added:
34. “plant biostimulant” means a product stimulating plant nutrition processes independently of the product’s nutrient content with the sole aim of

Status: Point in time view as at 05/06/2019.

Changes to legislation: There are currently no known outstanding effects for the Regulation (EU) 2019/1009 of the European Parliament and of the Council. (See end of Document for details)

improving one or more of the following characteristics of the plant or the plant rhizosphere:

- (a) nutrient use efficiency;
- (b) tolerance to abiotic stress;
- (c) quality traits;
- (d) availability of confined nutrients in soil or rhizosphere.;

(3) in Article 80, the following paragraph is added:

8. To a product which was granted an authorisation under Article 32(1) based on an application submitted before 15 July 2019, and which after that date falls under the definition in point 34 of Article 3, this Regulation shall continue to apply for the duration provided in the authorisation.

CHAPTER VIII **U.K.**

TRANSITIONAL AND FINAL PROVISIONS

Article 48 **U.K.**

Penalties

Member States shall lay down rules on penalties applicable to infringements of this Regulation and shall take all measures necessary to ensure that they are implemented. The penalties provided for shall be effective, proportionate and dissuasive. Member States shall, without delay, notify the Commission of those rules and of those measures and shall notify it, without delay, of any subsequent amendment affecting them.

Article 49 **U.K.**

Report

By 16 July 2026, the Commission shall submit to the European Parliament and to the Council a report assessing the application of this Regulation and its overall impact as to the attainment of its objectives, including the impact on small and medium-sized enterprises. That report shall include:

- (a) an assessment of the functioning of the internal market for fertilising products, including conformity assessment and market surveillance effectiveness and an analysis of the effects of optional harmonisation on production, market shares and trade flows of EU fertilising products and fertilising products placed on the market under national rules;
- (b) a review of the limit values for cadmium content in phosphate fertilisers, with a view to assessing the feasibility of reducing these limit values to a lower appropriate level on the basis of available technologies and scientific evidence on cadmium exposure and accumulation in the environment, taking into account environmental factors, in particular in the context of soil and climatic conditions, health factors, as well as socio-economic factors, including considerations of security of supply;

Status: Point in time view as at 05/06/2019.

Changes to legislation: There are currently no known outstanding effects for the Regulation (EU) 2019/1009 of the European Parliament and of the Council. (See end of Document for details)

- (c) an assessment of the application of restrictions on levels of contaminants set out in Annex I and an assessment of any new relevant scientific information as regards the toxicity and carcinogenicity of contaminants that becomes available, including the risks from uranium contamination in fertilising products.

The report shall take due account of technological progress and innovation as well as standardisation processes affecting production and use of fertilising products. It shall be accompanied, if appropriate, by a legislative proposal.

Article 50 **U.K.**

Biodegradability review

By 16 July 2024, the Commission shall carry out a review in order to assess the possibility of determining biodegradability criteria of mulch films, and the possibility of incorporating them into component material category 9 in Part II of Annex II.

Article 51 **U.K.**

Repeal of Regulation (EC) No 2003/2003

Regulation (EC) No 2003/2003 is repealed with effect from 16 July 2022.

References to the repealed Regulation shall be construed as references to this Regulation.

Article 52 **U.K.**

Transitional provisions

Member States shall not impede the making available on the market of products which were placed on the market as fertilisers designated ‘EC fertiliser’ in conformity with Regulation (EC) No 2003/2003 before 16 July 2022. However, Chapter V of this Regulation shall apply *mutatis mutandis* to such products.

Article 53 **U.K.**

Entry into force and application

This Regulation shall enter into force on the twentieth day following that of its publication in the *Official Journal of the European Union*.

It shall apply from 16 July 2022.

However:

- (a) Articles 4(3), 14, 42, 43, 44, 45, 46 and 47 shall apply from 15 July 2019; and
(b) Articles 20 to 36 shall apply from 16 April 2020.

This Regulation shall be binding in its entirety and directly applicable in all Member States.

Status: Point in time view as at 05/06/2019.

Changes to legislation: *There are currently no known outstanding effects for the Regulation (EU) 2019/1009 of the European Parliament and of the Council. (See end of Document for details)*

Done at Brussels, 5 June 2019.

For the European Parliament

The President

A. TAJANI

For the Council

The President

G. CIAMBA

Status: Point in time view as at 05/06/2019.

Changes to legislation: There are currently no known outstanding effects for the Regulation (EU) 2019/1009 of the European Parliament and of the Council. (See end of Document for details)

ANNEX I U.K.

Product Function Categories (PFCs) of EU fertilising products

PART I U.K.

DESIGNATION OF PFCs

1. Fertiliser U.K.
 - A. Organic fertiliser U.K.
 - I. Solid organic fertiliser
 - II. Liquid organic fertiliser
 - B. Organo-mineral fertiliser U.K.
 - I. Solid organo-mineral fertiliser
 - II. Liquid organo-mineral fertiliser
 - C. Inorganic fertiliser U.K.
 - I. Inorganic macronutrient fertiliser U.K.
 - (a) Solid inorganic macronutrient fertiliser
 - (i) Straight solid inorganic macronutrient fertiliser
 - (A) Straight solid inorganic macronutrient ammonium nitrate fertiliser of high nitrogen content
 - (ii) Compound solid inorganic macronutrient fertiliser
 - (A) Compound solid inorganic macronutrient ammonium nitrate fertiliser of high nitrogen content
 - (b) Liquid inorganic macronutrient fertiliser
 - (i) Straight liquid inorganic macronutrient fertiliser
 - (ii) Compound liquid inorganic macronutrient fertiliser
 - II. Inorganic micronutrient fertiliser U.K.
 - (a) Straight inorganic micronutrient fertiliser
 - (b) Compound inorganic micronutrient fertiliser
2. Liming material U.K.
3. Soil improver U.K.
 - A. Organic soil improver
 - B. Inorganic soil improver
4. Growing medium U.K.

Status: Point in time view as at 05/06/2019.

Changes to legislation: There are currently no known outstanding effects for the Regulation (EU) 2019/1009 of the European Parliament and of the Council. (See end of Document for details)

5. Inhibitor **U.K.**
 - A. Nitrification inhibitor
 - B. Denitrification inhibitor
 - C. Urease inhibitor
6. Plant biostimulant **U.K.**
 - A. Microbial plant biostimulant
 - B. Non-microbial plant biostimulant
7. Fertilising product blend **U.K.**

PART II **U.K.**

REQUIREMENTS RELATED TO PFCs

1. This Part sets out the requirements related to the PFCs to which EU fertilising products belong by virtue of their claimed function.
2. The requirements laid down in this Annex for a given PFC apply to EU fertilising products in all subcategories of that PFC.
3. The claim that an EU fertilising product complies with the function set out in this Annex for the relevant PFC shall be supported by the product's mode of action, the relative content of its various components, or any other relevant parameter.
4. Where compliance with a given requirement (such as absence of a given contaminant) follows certainly and uncontestably from the nature or manufacturing process of an EU fertilising product, that compliance can be presumed in the conformity assessment procedure without verification (such as testing), at the responsibility of the manufacturer.
5. Where the EU fertilising product contains a substance for which maximum residue limit values for food and feed have been established in accordance with: **U.K.**
 - (a) Council Regulation (EEC) No 315/93⁽³⁰⁾,
 - (b) Regulation (EC) No 396/2005 of the European Parliament and of the Council⁽³¹⁾,
 - (c) Regulation (EC) No 470/2009 of the European Parliament and of the Council⁽³²⁾, or
 - (d) Directive 2002/32/EC of the European Parliament and of the Council⁽³³⁾

the use of the EU fertilising product as specified in the use instructions must not lead to the exceedance of those limit values in food or feed.

6. Phosphonates shall not be intentionally added to any EU fertilising product. Unintentional presence of phosphonates shall not exceed 0,5 % by mass.
7. The requirements in this Annex are expressed in oxidised form for certain nutrients. Where compliance is assessed based on the presence of the nutrient in question in its elemental form, the following conversion factors shall be used: **U.K.**

Status: Point in time view as at 05/06/2019.

Changes to legislation: There are currently no known outstanding effects for the Regulation (EU) 2019/1009 of the European Parliament and of the Council. (See end of Document for details)

phosphorus (P)	= phosphorus pentoxide (P ₂ O ₅) × 0,436;
potassium (K)	= potassium oxide (K ₂ O) × 0,830;
calcium (Ca)	= calcium oxide (CaO) × 0,715;
magnesium (Mg)	= magnesium oxide (MgO) × 0,603;
sodium (Na)	= sodium oxide (Na ₂ O) × 0,742;
sulphur (S)	= sulphur trioxide (SO ₃) × 0,400.

8. The requirements in this Annex are expressed by reference to organic carbon (C_{org}). Where compliance is assessed based on organic matter the following conversion factor applies: **U.K.**

organic carbon (C_{org}) = organic matter × 0,56.

PFC 1: FERTILISER

A fertiliser shall be an EU fertilising product the function of which is to provide nutrients to plants or mushrooms.

PFC 1(A): ORGANIC FERTILISER

1. An organic fertiliser shall contain: **U.K.**
- organic carbon (C_{org}) and
 - nutrients

of solely biological origin.

An organic fertiliser may contain peat, leonardite and lignite, but no other material which is fossilized or embedded in geological formations.

2. Contaminants in an organic fertiliser must not exceed the following limit values: **U.K.**

- (a) cadmium (Cd) : 1,5 mg/kg dry matter,
- (b) hexavalent chromium (Cr VI) : 2 mg/kg dry matter,
- (c) mercury (Hg) : 1 mg/kg dry matter,
- (d) nickel (Ni) : 50 mg/kg dry matter,
- (e) lead (Pb) : 120 mg/kg dry matter, and
- (f) inorganic arsenic (As) : 40 mg/kg dry matter.

Biuret (C₂H₅N₃O₂) must not be present in an organic fertiliser.

3. The copper (Cu) content in an organic fertiliser must not exceed 300 mg/kg dry matter, and the zinc (Zn) content in an organic fertiliser must not exceed 800 mg/kg dry matter.
4. Pathogens in an organic fertiliser must not exceed the limits set out in the following table: **U.K.**

Micro-organisms to be tested	Sampling plans			Limit
	n	c	m	M
<i>Salmonella</i> spp.	5	0	0	Absence in 25 g or 25 ml

Status: Point in time view as at 05/06/2019.

Changes to legislation: There are currently no known outstanding effects for the Regulation (EU) 2019/1009 of the European Parliament and of the Council. (See end of Document for details)

<i>Escherichia coli</i> or <i>Enterococcaceae</i>	5	5	0	1 000 in 1 g or 1 ml
---	---	---	---	----------------------

Where:

- n = number of samples to be tested,
 c = number of samples where the number of bacteria expressed in colony forming units (CFU) is between m and M,
 m = threshold value for the number of bacteria expressed in CFU that is considered satisfactory,
 M = maximum value of the number of bacteria expressed in CFU.

PFC 1(A)(I): SOLID ORGANIC FERTILISER

1. A solid organic fertiliser shall be in solid form.
2. A solid organic fertiliser shall contain at least one of the following declared primary nutrients: nitrogen (N), phosphorus pentoxide (P₂O₅) or potassium oxide (K₂O). **U.K.**

Where a solid organic fertiliser contains only one declared primary nutrient, that nutrient content shall be at least the following:

- (a) 2,5 % by mass of total nitrogen (N),
- (b) 2 % by mass of total phosphorus pentoxide (P₂O₅), or
- (c) 2 % by mass of total potassium oxide (K₂O).

Where a solid organic fertiliser contains more than one declared primary nutrient, those nutrient contents shall be at least the following:

- (a) 1 % by mass of total nitrogen (N),
- (b) 1 % by mass of total phosphorus pentoxide (P₂O₅), or
- (c) 1 % by mass of total potassium oxide (K₂O).

The sum of those nutrient contents shall be at least 4 % by mass.

3. Organic carbon (C_{org}) content in a solid organic fertiliser shall be at least 15 % by mass.
- PFC 1(A)(II): LIQUID ORGANIC FERTILISER**

1. A liquid organic fertiliser shall be in liquid form.
2. A liquid organic fertiliser shall contain at least one of the following declared primary nutrients: nitrogen (N), phosphorus pentoxide (P₂O₅) or potassium oxide (K₂O). **U.K.**

Where a liquid organic fertiliser contains only one declared primary nutrient, that nutrient content shall be at least the following:

- (a) 2 % by mass of total nitrogen (N),
- (b) 1 % by mass of total phosphorus pentoxide (P₂O₅), or
- (c) 2 % by mass of total potassium oxide (K₂O).

Status: Point in time view as at 05/06/2019.

Changes to legislation: There are currently no known outstanding effects for the Regulation (EU) 2019/1009 of the European Parliament and of the Council. (See end of Document for details)

Where a liquid organic fertiliser contains more than one declared primary nutrient, those nutrient contents shall be at least the following:

- (a) 1 % by mass of total nitrogen (N),
- (b) 1 % by mass of total phosphorus pentoxide (P₂O₅), or
- (c) 1 % by mass of total potassium oxide (K₂O).

The sum of those nutrient contents shall be at least 3 % by mass.

3. Organic carbon (C_{org}) content in a liquid organic fertiliser shall be at least 5 % by mass.
PFC 1(B): ORGANO-MINERAL FERTILISER

1. An organo-mineral fertiliser shall be a co-formulation of: **U.K.**
 - (a) one or more inorganic fertilisers, as specified in PFC 1(C), and
 - (b) one or more materials containing:
 - organic carbon (C_{org}); and
 - nutrients
 of solely biological origin.

An organo-mineral fertiliser may contain peat, leonardite and lignite, but no other material which is fossilized or embedded in geological formations.

2. Where one or more of the inorganic fertilisers in the co-formulation is a straight or compound solid inorganic macronutrient ammonium nitrate fertiliser of high nitrogen content, as specified in PFC 1(C)(I)(a)(i-ii)(A), an organo-mineral fertiliser shall not contain 16 % or more by mass of nitrogen (N) as a result of ammonium nitrate (NH₄NO₃).
3. Contaminants in an organo-mineral fertiliser must not exceed the following limit values: **U.K.**
 - (a) cadmium (Cd) : (i) where an organo-mineral fertiliser has a total phosphorus (P) content of less than 5 % phosphorus pentoxide (P₂O₅)-equivalent by mass: 3 mg/kg dry matter, or
 - (ii) where an organo-mineral fertiliser has a total phosphorus (P) content of 5 % phosphorus pentoxide (P₂O₅)-equivalent or more by mass ('phosphate fertiliser'): 60 mg/kg phosphorus pentoxide (P₂O₅);
 - (b) hexavalent chromium (Cr VI) : 2 mg/kg dry matter;
 - (c) mercury (Hg) : 1 mg/kg dry matter;
 - (d) nickel (Ni) : 50 mg/kg dry matter;
 - (e) lead (Pb) : 120 mg/kg dry matter;
 - (f) inorganic arsenic (As) : 40 mg/kg dry matter; and
 - (g) biuret (C₂H₅N₃O₂) : 12 g/kg dry matter.
4. The copper (Cu) content in an organo-mineral fertiliser must not exceed 600 mg/kg dry matter, and the zinc (Zn) content in an organo-mineral fertiliser must not exceed 1 500 mg/kg dry matter. However, these limit values shall not apply where copper (Cu)

Status: Point in time view as at 05/06/2019.

Changes to legislation: There are currently no known outstanding effects for the Regulation (EU) 2019/1009 of the European Parliament and of the Council. (See end of Document for details)

or zinc (Zn) has been intentionally added to an organo-mineral fertiliser for the purpose of correcting a soil micronutrient deficiency and is declared in accordance with Annex III.

5. Pathogens in an organo-mineral fertiliser must not exceed the limits set out in the following table: **U.K.**

Micro-organisms to be tested	Sampling plans			Limit
	n	c	m	M
<i>Salmonella</i> spp.	5	0	0	Absence in 25 g or 25 ml
<i>Escherichia coli</i> or <i>Enterococcaceae</i>	5	5	0	1 000 in 1 g or 1 ml

Where:

- n = number of samples to be tested,
 c = number of samples where the number of bacteria expressed in CFU is between m and M,
 m = threshold value for the number of bacteria expressed in CFU that is considered satisfactory,
 M = maximum value of the number of bacteria expressed in CFU.

PFC 1(B)(I): SOLID ORGANO-MINERAL FERTILISER

1. A solid organo-mineral fertiliser shall be in solid form.
2. A solid organo-mineral fertiliser shall contain at least one of the following declared primary nutrients: nitrogen (N), phosphorus pentoxide (P₂O₅) or potassium oxide (K₂O). **U.K.**

Where a solid organo-mineral fertiliser contains only one declared primary nutrient, that nutrient content shall be at least the following:

- (a) 2,5 % by mass of total nitrogen (N), out of which 1 % by mass shall be organic nitrogen (N_{org}),
- (b) 2 % by mass of total phosphorus pentoxide (P₂O₅), or
- (c) 2 % by mass of total potassium oxide (K₂O).

Where a solid organo-mineral fertiliser contains more than one declared primary nutrient, those nutrient contents shall be at least the following:

- (a) 2 % by mass of total nitrogen (N), out of which 0,5 % by mass shall be organic nitrogen (N_{org}),
- (b) 2 % by mass of total phosphorus pentoxide (P₂O₅), or
- (c) 2 % by mass of total potassium oxide (K₂O).

The sum of those nutrient contents shall be at least 8 % by mass.

3. Organic carbon (C_{org}) content in a solid organo-mineral fertiliser shall be at least 7,5 % by mass.

Status: Point in time view as at 05/06/2019.

Changes to legislation: There are currently no known outstanding effects for the Regulation (EU) 2019/1009 of the European Parliament and of the Council. (See end of Document for details)

4. In a solid organo-mineral fertiliser, each physical unit shall contain organic carbon (C_{org}) and all the nutrients in their declared content. A physical unit refers to one of the component pieces of a product, such as granules or pellets.

PFC 1(B)(II): LIQUID ORGANO-MINERAL FERTILISER

1. A liquid organo-mineral fertiliser shall be in liquid form.
2. A liquid organo-mineral fertiliser shall contain at least one of the following declared primary nutrients: nitrogen (N), phosphorus pentoxide (P_2O_5) or potassium oxide (K_2O). U.K.

Where a liquid organo-mineral fertiliser contains only one declared primary nutrient, that nutrient content shall be at least the following:

- (a) 2 % by mass of total nitrogen (N), out of which 0,5 % by mass shall be organic nitrogen (N_{org}),
- (b) 2 % by mass of total phosphorus pentoxide (P_2O_5), or
- (c) 2 % by mass of total potassium oxide (K_2O).

Where a liquid organo-mineral fertiliser contains more than one declared primary nutrient, those nutrient contents shall be at least the following:

- (a) 2 % by mass of total nitrogen (N), out of which 0,5 % by mass shall be organic nitrogen (N_{org}),
- (b) 2 % by mass of total phosphorus pentoxide (P_2O_5), or
- (c) 2 % by mass of total potassium oxide (K_2O).

The sum of those nutrient contents shall be at least 6 % by mass.

3. Organic carbon (C_{org}) content in a liquid organo-mineral fertiliser shall be at least 3 % by mass.

PFC 1(C): INORGANIC FERTILISER

1. An inorganic fertiliser shall be a fertiliser containing or releasing nutrients in a mineral form, other than an organic or organo-mineral fertiliser.
2. In addition to the requirements of either PFC 1(C)(I) or PFC 1(C)(II), an inorganic fertiliser which contains more than 1 % by mass of organic carbon (C_{org}), other than organic carbon (C_{org}) from: U.K.
 - chelating or complexing agents referred to in point 3 of component material category (CMC) 1 in Part II of Annex II,
 - nitrification inhibitors, denitrification inhibitors or urease inhibitors referred to in point 4 of CMC 1 in Part II of Annex II,
 - coating agents referred to in point 1(a) of CMC 9 in Part II of Annex II,
 - urea (CH_4N_2O), or
 - calcium cyanamide ($CaCN_2$)

shall meet the requirement that pathogens in an inorganic fertiliser must not exceed the limits set out in the following table:

Status: Point in time view as at 05/06/2019.

Changes to legislation: There are currently no known outstanding effects for the Regulation (EU) 2019/1009 of the European Parliament and of the Council. (See end of Document for details)

Micro-organisms to be tested	Sampling plans			Limit
	n	c	m	M
<i>Salmonella</i> spp.	5	0	0	Absence in 25 g or 25 ml
<i>Escherichia coli</i> or <i>Enterococcaceae</i>	5	5	0	1 000 in 1 g or 1 ml

Where:

- n = number of samples to be tested,
 c = number of samples where the number of bacteria expressed in CFU is between m and M,
 m = threshold value for the number of bacteria expressed in CFU that is considered satisfactory,
 M = maximum value of the number of bacteria expressed in CFU.

PFC 1(C)(I): INORGANIC MACRONUTRIENT FERTILISER

1. An inorganic macronutrient fertiliser shall be aimed at providing plants or mushrooms with one or more of the following macronutrients: **U.K.**
 - (a) primary macronutrients: nitrogen (N), phosphorus (P) or potassium (K),
 - (b) secondary macronutrients: calcium (Ca), magnesium (Mg), sodium (Na) or sulphur (S).
2. Contaminants in an inorganic macronutrient fertiliser must not exceed the following limit values: **U.K.**
 - (a) cadmium (Cd) : (i) where an inorganic macronutrient fertiliser has a total phosphorus (P) content of less than 5 % phosphorus pentoxide (P₂O₅)-equivalent by mass: 3 mg/kg dry matter, or
 - (ii) where an inorganic macronutrient fertiliser has a total phosphorus (P) content of 5 % phosphorus pentoxide (P₂O₅)-equivalent or more by mass ('phosphate fertiliser'): 60 mg/kg phosphorus pentoxide (P₂O₅);
 - (b) hexavalent chromium (Cr VI) : 2 mg/kg dry matter,
 - (c) mercury (Hg) : 1 mg/kg dry matter,
 - (d) nickel (Ni) : 100 mg/kg dry matter,
 - (e) lead (Pb) : 120 mg/kg dry matter,
 - (f) arsenic (As) : 40 mg/kg dry matter,
 - (g) biuret : 12 g/kg dry matter,
(C₂H₅N₃O₂)
 - (h) perchlorate : 50 mg/kg dry matter.
(ClO₄⁻)
3. The copper (Cu) content in an inorganic macronutrient fertiliser must not exceed 600 mg/kg dry matter, and the zinc (Zn) content in an inorganic macronutrient fertiliser must not exceed 1 500 mg/kg dry matter. However, these limit values shall not apply where copper (Cu) or zinc (Zn) has been intentionally added to an inorganic

Status: Point in time view as at 05/06/2019.

Changes to legislation: There are currently no known outstanding effects for the Regulation (EU) 2019/1009 of the European Parliament and of the Council. (See end of Document for details)

macronutrient fertiliser for the purpose of correcting a soil micronutrient deficiency and is declared in accordance with Annex III.

PFC 1(C)(I)(a): SOLID INORGANIC MACRONUTRIENT FERTILISER

A solid inorganic macronutrient fertiliser shall be in solid form.

PFC 1(C)(I)(a)(i): STRAIGHT SOLID INORGANIC MACRONUTRIENT FERTILISER

1. A straight solid inorganic macronutrient fertiliser shall have a declared content of: **U.K.**
 - (a) only one macronutrient (nitrogen (N), phosphorus (P), potassium (K), calcium (Ca), magnesium (Mg), sodium (Na), sulphur (S)), or
 - (b) only one primary macronutrient (nitrogen (N), phosphorus (P), potassium (K)) and one or more secondary macronutrients (calcium (Ca), magnesium (Mg), sodium (Na), sulphur (S)).
2. Where a straight solid inorganic macronutrient fertiliser contains only one declared macronutrient (nitrogen (N), phosphorus (P), potassium (K), calcium (Ca), magnesium (Mg), sodium (Na), sulphur (S)), that macronutrient content shall be at least the following: **U.K.**
 - (a) 10 % by mass of total nitrogen (N),
 - (b) 12 % by mass of total phosphorus pentoxide (P₂O₅),
 - (c) 6 % by mass of total potassium oxide (K₂O),
 - (d) 5 % by mass of total magnesium oxide (MgO),
 - (e) 12 % by mass of total calcium oxide (CaO),
 - (f) 10 % by mass of total sulphur trioxide (SO₃), or
 - (g) 1 % by mass of total sodium oxide (Na₂O).

However, the total sodium oxide (Na₂O) content shall not exceed 40 % by mass.

Where a straight solid inorganic macronutrient fertiliser contains only one declared primary macronutrient (nitrogen (N), phosphorus (P), potassium (K)) and one or more declared secondary macronutrients (calcium (Ca), magnesium (Mg), sodium (Na), sulphur (S)):

- (a) that primary macronutrient content shall be at least the following:
 - (i) 3 % by mass of total nitrogen (N),
 - (ii) 3 % by mass of total phosphorus pentoxide (P₂O₅), or
 - (iii) 3 % by mass of total potassium oxide (K₂O);
- (b) that or those secondary macronutrient contents shall be at least the following:
 - (i) 1,5 % by mass of total magnesium oxide (MgO),
 - (ii) 1,5 % by mass of total calcium oxide (CaO),
 - (iii) 1,5 % by mass of total sulphur trioxide (SO₃), or
 - (iv) 1 % by mass of total sodium oxide (Na₂O).

Status: Point in time view as at 05/06/2019.

Changes to legislation: There are currently no known outstanding effects for the Regulation (EU) 2019/1009 of the European Parliament and of the Council. (See end of Document for details)

However, the total sodium oxide (Na₂O) content shall not exceed 40 % by mass.

The sum of all declared primary and secondary macronutrient contents shall be at least 18 % by mass.

PFC 1(C)(I)(a)(ii): COMPOUND SOLID INORGANIC MACRONUTRIENT FERTILISER

1. A compound solid inorganic macronutrient fertiliser shall have a declared content of: **U.K.**
 - (a) more than one primary macronutrient (nitrogen (N), phosphorus (P), potassium (K)), or
 - (b) more than one secondary macronutrient (calcium (Ca), magnesium (Mg), sodium (Na), sulphur (S)) and no primary macronutrient (nitrogen (N), phosphorus (P), potassium (K)).
2. A compound solid inorganic macronutrient fertiliser shall contain more than one of the following declared macronutrients in at least the following contents: **U.K.**
 - (a) 3 % by mass of total nitrogen (N),
 - (b) 3 % by mass of total phosphorus pentoxide (P₂O₅),
 - (c) 3 % by mass of total potassium oxide (K₂O),
 - (d) 1,5 % by mass of total magnesium oxide (MgO),
 - (e) 1,5 % by mass of total calcium oxide (CaO),
 - (f) 1,5 % by mass of total sulphur trioxide (SO₃), or
 - (g) 1 % by mass of total sodium oxide (Na₂O).

However, the total sodium oxide (Na₂O) content shall not exceed 40 % by mass.

The sum of all declared macronutrient contents shall be at least 18 % by mass.

PFC 1(C)(I)(a)(i-ii)(A): STRAIGHT OR COMPOUND SOLID INORGANIC MACRONUTRIENT AMMONIUM NITRATE FERTILISER OF HIGH NITROGEN CONTENT

1. A straight or compound solid inorganic macronutrient ammonium nitrate fertiliser of high nitrogen content shall be ammonium nitrate (NH₄NO₃)-based and contain 28 % or more by mass of nitrogen (N) as a result of ammonium nitrate (NH₄NO₃).
2. Any matter other than ammonium nitrate (NH₄NO₃) shall be inert towards ammonium nitrate (NH₄NO₃).
3. A straight or compound solid inorganic macronutrient ammonium nitrate fertiliser of high nitrogen content shall be made available to the end-user only in packaged form. The package shall be closed in such a way or by such a device that, when it is opened, the fastening, the fastening seal or the package itself is irreparably damaged. Valve sacks may be used.
4. The oil retention of a straight or compound solid inorganic macronutrient ammonium nitrate fertiliser of high nitrogen content, following two thermal cycles as described under point 4.1 in Module A1 in Part II of Annex IV, must not exceed 4 % by mass.

Status: Point in time view as at 05/06/2019.

Changes to legislation: There are currently no known outstanding effects for the Regulation (EU) 2019/1009 of the European Parliament and of the Council. (See end of Document for details)

5. The detonation resistance of a straight or compound solid inorganic macronutrient ammonium nitrate fertiliser of high nitrogen content shall be such, that: **U.K.**
- following five thermal cycles as described under point 4.3 in Module A1 in Part II of Annex IV,
 - in two detonation resistance tests as described under point 4.4 in Module A1 in Part II of Annex IV,

one or more of the supporting lead cylinders is crushed by less than 5 %.

6. The % by mass of combustible material measured as carbon (C) must not exceed: **U.K.**
- 0,2 % for a straight or compound solid inorganic macronutrient ammonium nitrate fertiliser of high nitrogen content having a nitrogen (N) content of at least 31,5 % by mass, and
 - 0,4 % for a straight or compound solid inorganic macronutrient ammonium nitrate fertiliser of high nitrogen content having a nitrogen (N) content of at least 28 % but less than 31,5 % by mass.
7. A solution of 10 g of a straight or compound solid inorganic macronutrient ammonium nitrate fertiliser of high nitrogen content in 100 ml of water must have a pH of at least 4,5.
8. Not more than 5 % by mass shall pass through a 1 mm mesh sieve, and not more than 3 % by mass shall pass through a 0,5 mm mesh sieve.
9. The copper (Cu) content shall not be higher than 10 mg/kg, and the chlorine (Cl) content shall not be higher than 200 mg/kg.

PFC 1(C)(I)(b): LIQUID INORGANIC MACRONUTRIENT FERTILISER

A liquid inorganic macronutrient fertiliser shall be in liquid form.

PFC 1(C)(I)(b)(i): STRAIGHT LIQUID INORGANIC MACRONUTRIENT FERTILISER

1. A straight liquid inorganic macronutrient fertiliser shall have a declared content of: **U.K.**
- (a) only one macronutrient (nitrogen (N), phosphorus (P), potassium (K), calcium (Ca), magnesium (Mg), sodium (Na), sulphur (S)), or
 - (b) only one primary macronutrient (nitrogen (N), phosphorus (P), potassium (K)) and one or more secondary macronutrients (calcium (Ca), magnesium (Mg), sodium (Na), sulphur (S)).
2. Where a straight liquid inorganic macronutrient fertiliser contains only one declared macronutrient (nitrogen (N), phosphorus (P), potassium (K), calcium (Ca), magnesium (Mg), sodium (Na), sulphur (S)), that macronutrient content shall be at least the following: **U.K.**
- (a) 5 % by mass of total nitrogen (N),
 - (b) 5 % by mass of total phosphorus pentoxide (P₂O₅),
 - (c) 3 % by mass of total potassium oxide (K₂O),
 - (d) 2 % by mass of total magnesium oxide (MgO),
 - (e) 6 % by mass of total calcium oxide (CaO),

Status: Point in time view as at 05/06/2019.

Changes to legislation: There are currently no known outstanding effects for the Regulation (EU) 2019/1009 of the European Parliament and of the Council. (See end of Document for details)

(f) 5 % by mass of total sulphur trioxide (SO₃), or

(g) 1 % by mass of total sodium oxide (Na₂O).

However, the total sodium oxide (Na₂O) content shall not exceed 40 % by mass.

Where a straight liquid inorganic macronutrient fertiliser contains only one declared primary macronutrient (nitrogen (N), phosphorus (P), potassium (K)), and one or more declared secondary macronutrients (calcium (Ca), magnesium (Mg), sodium (Na), sulphur (S)):

(a) that primary macronutrient content shall be at least the following:

(i) 1,5 % by mass of total nitrogen (N),

(ii) 1,5 % by mass of total phosphorus pentoxide (P₂O₅), or

(iii) 1,5 % by mass of total potassium oxide (K₂O); and

(b) that or those secondary macronutrient contents shall be at least the following:

(i) 0,75 % by mass of total magnesium oxide (MgO),

(ii) 0,75 % by mass of total calcium oxide (CaO),

(iii) 0,75 % by mass of total sulphur trioxide (SO₃), or

(iv) 0,5 % by mass of total sodium oxide (Na₂O).

However, the total sodium oxide (Na₂O) content shall not exceed 20 % by mass.

The sum of all declared primary and secondary macronutrient contents shall be at least 7 % by mass.

PFC 1(C)(I)(b)(ii): COMPOUND LIQUID INORGANIC MACRONUTRIENT FERTILISER

1. A compound liquid inorganic macronutrient fertiliser shall have a declared content of: **U.K.**

(a) more than one primary macronutrient (nitrogen (N), phosphorus (P), potassium (K)), or

(b) more than one secondary macronutrient (calcium (Ca), magnesium (Mg), sodium (Na), sulphur (S)), and no primary macronutrient (nitrogen (N), phosphorus (P), potassium (K)).

2. A compound liquid inorganic macronutrient fertiliser shall contain more than one of the following declared nutrients in at least the following contents: **U.K.**

(a) 1,5 % by mass of total nitrogen (N),

(b) 1,5 % by mass of total phosphorus pentoxide (P₂O₅),

(c) 1,5 % by mass of total potassium oxide (K₂O),

(d) 0,75 % by mass of total magnesium oxide (MgO),

(e) 0,75 % by mass of total calcium oxide (CaO),

(f) 0,75 % by mass of total sulphur trioxide (SO₃), or

(g) 0,5 % by mass of total sodium oxide (Na₂O).

Status: Point in time view as at 05/06/2019.

Changes to legislation: There are currently no known outstanding effects for the Regulation (EU) 2019/1009 of the European Parliament and of the Council. (See end of Document for details)

However, the total sodium oxide (Na₂O) content shall not exceed 20 % by mass.

The sum of all declared nutrient contents shall be at least 7 % by mass.

PFC 1(C)(II): INORGANIC MICRONUTRIENT FERTILISER

1. An inorganic micronutrient fertiliser shall be an inorganic fertiliser other than an inorganic macronutrient fertiliser aimed at providing plants or mushrooms with one or more of the following micronutrients: boron (B), cobalt (Co), copper (Cu), iron (Fe), manganese (Mn), molybdenum (Mo) or zinc (Zn).
2. Inorganic micronutrient fertilisers shall be made available to the end-user only in packaged form.
3. Contaminants in an inorganic micronutrient fertiliser must not exceed the following limit values: **U.K.**

Contaminant	Limit values of contaminants expressed in mg, in relation to the total micronutrient content expressed in kg(mg/kg of total micronutrient content, which means boron (B), cobalt (Co), copper (Cu), iron (Fe), manganese (Mn), molybdenum (Mo) and zinc (Zn))
Arsenic (As)	1 000
Cadmium (Cd)	200
Lead (Pb)	600
Mercury (Hg)	100
Nickel (Ni)	2 000

PFC 1(C)(II)(a): STRAIGHT INORGANIC MICRONUTRIENT FERTILISER

1. A straight inorganic micronutrient fertiliser shall have a declared content of not more than one micronutrient.
2. A straight inorganic micronutrient fertiliser shall belong to one of the typologies, and shall comply with the corresponding description and minimum micronutrient content requirements in the following table: **U.K.**

Typology	Description	Minimum micronutrient content
Micronutrient salt fertiliser	A chemically obtained straight solid inorganic micronutrient fertiliser containing a mineral ion salt as its essential ingredient	10 % by mass of micronutrient salt fertiliser shall consist of a water-soluble micronutrient
Micronutrient oxide or hydroxide fertiliser	A chemically obtained straight solid inorganic micronutrient fertiliser containing oxide or	10 % by mass of a micronutrient oxide or hydroxide fertiliser shall consist of a micronutrient

a UVCB: Substance of unknown or variable composition, complex reaction products or biological materials.

Status: Point in time view as at 05/06/2019.

Changes to legislation: There are currently no known outstanding effects for the Regulation (EU) 2019/1009 of the European Parliament and of the Council. (See end of Document for details)

	hydroxide as its essential ingredient	
Micronutrient-based fertiliser	A straight inorganic micronutrient fertiliser combining a micronutrient salt fertiliser with one or more other micronutrient salt fertilisers and/or with a single micronutrient chelate	5 % by mass of a micronutrient-based fertiliser shall consist of a micronutrient
Micronutrient solution fertiliser	An aqueous solution of different forms of a straight inorganic micronutrient fertiliser	2 % by mass of a micronutrient solution fertiliser shall consist of a water-soluble micronutrient
Micronutrient suspension fertiliser	A suspension of different forms of a straight inorganic micronutrient fertiliser	2 % by mass of a micronutrient suspension fertiliser shall consist of a micronutrient
Micronutrient chelate fertiliser	A water-soluble straight inorganic micronutrient fertiliser in which the declared micronutrient is chemically combined with chelating agent(s) fulfilling the requirements of CMC 1 in Part II of Annex II	— 5 % by mass of a micronutrient chelate fertiliser shall consist of a water-soluble micronutrient, and — at least 80 % of the water-soluble micronutrient shall be chelated by a chelating agent fulfilling the requirements of CMC 1 in Part II of Annex II
UVCB ^a iron chelates	A water-soluble straight inorganic micronutrient fertiliser in which the declared iron is chemically combined with chelating agent(s) fulfilling the requirements of CMC 1 in Part II of Annex II	— 5 % by mass of UVCB iron chelates shall consist of water-soluble iron, and — at least 80 % of the water-soluble iron shall be chelated and at least 50 % of the water soluble iron shall be chelated by a chelating agent fulfilling the requirements of CMC 1 in Part II of Annex II

^a UVCB: Substance of unknown or variable composition, complex reaction products or biological materials.

Status: Point in time view as at 05/06/2019.

Changes to legislation: There are currently no known outstanding effects for the Regulation (EU) 2019/1009 of the European Parliament and of the Council. (See end of Document for details)

Micronutrient complex fertiliser	A water-soluble straight inorganic micronutrient fertiliser in which the declared micronutrient is chemically combined with complexing agent(s) fulfilling the requirements of CMC 1 in Part II of Annex II	— 5 % by mass of a micronutrient complex fertiliser shall consist of a water-soluble micronutrient, and at least 80 % of the water-soluble micronutrient shall be complexed by a complexing agent fulfilling the requirements of CMC 1 in Part II of Annex II
----------------------------------	---	---

a UVCB: Substance of unknown or variable composition, complex reaction products or biological materials.

PFC 1(C)(II)(b): COMPOUND INORGANIC MICRONUTRIENT FERTILISER

1. A compound inorganic micronutrient fertiliser shall have a declared content of more than one micronutrient.
2. The sum of all declared micronutrient contents in a compound inorganic micronutrient fertiliser shall be at least: **U.K.**
 - (a) 2 % by mass for fertilisers in liquid form;
 - (b) 5 % by mass for fertilisers in solid form.

PFC 2: LIMING MATERIAL

1. A liming material shall be an EU fertilising product the function of which is to correct soil acidity. **U.K.**

A liming material shall contain oxides, hydroxides, carbonates or silicates of the nutrients calcium (Ca) or magnesium (Mg).

2. Contaminants in a liming material must not exceed the following limit values: **U.K.**
 - (a) cadmium (Cd) : 2 mg/kg dry matter,
 - (b) hexavalent chromium (Cr VI) : 2 mg/kg dry matter,
 - (c) mercury (Hg) : 1 mg/kg dry matter,
 - (d) nickel (Ni) : 90 mg/kg dry matter,
 - (e) lead (Pb) : 120 mg/kg dry matter,
 - (f) arsenic (As) : 40 mg/kg dry matter.
3. The copper (Cu) content in a liming material must not exceed 300 mg/kg dry matter, and the zinc (Zn) content in a liming material must not exceed 800 mg/kg dry matter.
4. The following parameters determined on the basis of the mass of a liming material shall be met: **U.K.**
 - (a) minimum neutralising value: 15 (equivalent CaO) or 9 (equivalent HO-),
 - (b) minimum reactivity: 10 % (hydrochloric acid test) or 50 % after 6 months (incubation test), and

Status: Point in time view as at 05/06/2019.

Changes to legislation: There are currently no known outstanding effects for the Regulation (EU) 2019/1009 of the European Parliament and of the Council. (See end of Document for details)

- (c) minimum grain size: at least 70 % < 1 mm, except for burnt limes, granulated liming material and chalk (at least 70 % of the liming material shall pass through a 1 mm sieve).

PFC 3: SOIL IMPROVER

A soil improver shall be an EU fertilising product the function of which is to maintain, improve or protect the physical or chemical properties, the structure or the biological activity of the soil to which it is added.

PFC 3(A): ORGANIC SOIL IMPROVER

1. An organic soil improver shall consist of material 95 % of which is of solely biological origin. **U.K.**

An organic soil improver may contain peat, leonardite and lignite, but no other material which is fossilized or embedded in geological formations.

2. Contaminants in an organic soil improver must not exceed the following limit values: **U.K.**

- (a) cadmium (Cd) : 2 mg/kg dry matter,
 (b) hexavalent chromium (Cr VI) : 2 mg/kg dry matter,
 (c) mercury (Hg) : 1 mg/kg dry matter,
 (d) nickel (Ni) : 50 mg/kg dry matter,
 (e) lead (Pb) : 120 mg/kg dry matter, and
 (f) inorganic arsenic (As) : 40 mg/kg dry matter.

3. The copper (Cu) content in an organic soil improver must not exceed 300 mg/kg dry matter, and the zinc (Zn) content in an organic soil improver must not exceed 800 mg/kg dry matter.

4. Pathogens in an organic soil improver must not exceed the limits set out in the following table: **U.K.**

Micro-organisms to be tested	Sampling plans			Limit
	n	c	m	M
<i>Salmonella</i> spp.	5	0	0	Absence in 25 g or 25 ml
<i>Escherichia coli</i> or <i>Enterococcaceae</i>	5	5	0	1 000 in 1 g or 1 ml

Where:

- n = number of samples to be tested,
 c = number of samples where the number of bacteria expressed in CFU is between m and M,
 m = threshold value for the number of bacteria expressed in CFU that is considered satisfactory,
 M = maximum value of the number of bacteria expressed in CFU.

5. An organic soil improver shall contain 20 % or more dry matter.

Status: Point in time view as at 05/06/2019.

Changes to legislation: There are currently no known outstanding effects for the Regulation (EU) 2019/1009 of the European Parliament and of the Council. (See end of Document for details)

6. Organic carbon (C_{org}) content in an organic soil improver shall be at least 7,5 % by mass.

PFC 3(B): INORGANIC SOIL IMPROVER

1. An inorganic soil improver shall be a soil improver other than an organic soil improver.
2. Contaminants in an inorganic soil improver must not exceed the following limit values: **U.K.**

- (a) cadmium (Cd) : 1,5 mg/kg dry matter,
 (b) hexavalent chromium (Cr VI) : 2 mg/kg dry matter,
 (c) mercury (Hg) : 1 mg/kg dry matter,
 (d) nickel (Ni) : 100 mg/kg dry matter,
 (e) lead (Pb) : 120 mg/kg dry matter,
 (f) inorganic arsenic (As) : 40 mg/kg dry matter.

3. The copper (Cu) content in an inorganic soil improver must not exceed 300 mg/kg dry matter, and the zinc (Zn) content in an inorganic soil improver must not exceed 800 mg/kg dry matter.

PFC 4: GROWING MEDIUM

1. A growing medium shall be an EU fertilising product other than soil in situ, the function of which is for plants or mushrooms to grow in. **U.K.**

For the purpose of this point, plants include algae.

2. Contaminants in a growing medium must not exceed the following limit values: **U.K.**

- (a) cadmium (Cd) : 1,5 mg/kg dry matter,
 (b) hexavalent chromium (Cr VI) : 2 mg/kg dry matter,
 (c) mercury (Hg) : 1 mg/kg dry matter,
 (d) nickel (Ni) : 50 mg/kg dry matter,
 (e) lead (Pb) : 120 mg/kg dry matter, and
 (f) inorganic arsenic (As) : 40 mg/kg dry matter.

3. The copper (Cu) content in a growing medium must not exceed 200 mg/kg dry matter, and the zinc (Zn) content in a growing medium must not exceed 500 mg/kg dry matter.

4. Pathogens in a growing medium must not exceed the limits set out in the following table: **U.K.**

Micro-organisms to be tested	Sampling plans			Limit M
	n	c	m	
<i>Salmonella</i> spp.	5	0	0	Absence in 25 g or 25 ml
<i>Escherichia coli</i> or <i>Enterococcaceae</i>	5	5	0	1 000 in 1 g or 1 ml

Status: Point in time view as at 05/06/2019.

Changes to legislation: There are currently no known outstanding effects for the Regulation (EU) 2019/1009 of the European Parliament and of the Council. (See end of Document for details)

Where:

- n = number of samples to be tested,
 c = number of samples where the number of bacteria expressed in CFU is between m and M,
 m = threshold value for the number of bacteria expressed in CFU that is considered satisfactory,
 M = maximum value of the number of bacteria expressed in CFU.

PFC 5: INHIBITOR

An inhibitor shall be an EU fertilising product the function of which is to improve the nutrient release patterns of a product providing plants with nutrients by delaying or stopping the activity of specific groups of micro-organisms or enzymes.

PFC 5(A): NITRIFICATION INHIBITOR

1. A nitrification inhibitor shall inhibit the biological oxidation of ammoniacal nitrogen ($\text{NH}_3\text{-N}$) to nitrite nitrogen (NO_2^-), thus slowing the formation of nitrate nitrogen (NO_3^-).
2. The ammoniacal nitrogen ($\text{NH}_3\text{-N}$) oxidation rate shall be measured by: **U.K.**
 - (a) ammoniacal nitrogen ($\text{NH}_3\text{-N}$) disappearance, or
 - (b) the sum of nitrite nitrogen (NO_2^-) and nitrate nitrogen (NO_3^-) production with respect to time.

Compared to a control sample where the nitrification inhibitor has not been added, a soil sample containing the nitrification inhibitor shall show a 20 % reduction in ammoniacal nitrogen ($\text{NH}_3\text{-N}$) oxidation rate based on an analysis carried out 14 days after application at the 95 % confidence level.

PFC 5(B): DENITRIFICATION INHIBITOR

1. A denitrification inhibitor shall inhibit the formation of nitrous oxide (N_2O) by slowing down or blocking the conversion of nitrate (NO_3^-) to dinitrogen (N_2) without influencing the nitrification process as described in PFC 5(A).
2. Compared to a control sample where the denitrification inhibitor has not been added, an *in vitro* test containing the denitrification inhibitor shall show a 20 % reduction in rate of the release of nitrous oxide (N_2O) based on an analysis carried out 14 days after application at the 95 % confidence level.

PFC 5(C): UREASE INHIBITOR

1. A urease inhibitor shall inhibit hydrolytic action on urea ($\text{CH}_4\text{N}_2\text{O}$) by the urease enzyme, primarily targeted to reduce ammonia volatilisation.
2. Compared to a control sample where the urease inhibitor has not been added, an *in vitro* test containing the urease inhibitor shall show a 20 % reduction in the rate of hydrolysis of urea ($\text{CH}_4\text{N}_2\text{O}$) based on an analysis carried out 14 days after application at the 95 % confidence level.

PFC 6: PLANT BIOSTIMULANT

1. A plant biostimulant shall be an EU fertilising product the function of which is to stimulate plant nutrition processes independently of the product's nutrient content with the sole aim of improving one or more of the following characteristics of the plant or the plant rhizosphere: **U.K.**

Status: Point in time view as at 05/06/2019.

Changes to legislation: There are currently no known outstanding effects for the Regulation (EU) 2019/1009 of the European Parliament and of the Council. (See end of Document for details)

- (a) nutrient use efficiency,
 - (b) tolerance to abiotic stress,
 - (c) quality traits, or
 - (d) availability of confined nutrients in the soil or rhizosphere.
2. Contaminants in a plant biostimulant must not exceed the following limit values: **U.K.**
- (a) cadmium (Cd) : 1,5 mg/kg dry matter,
 - (b) hexavalent chromium (Cr VI) : 2 mg/kg dry matter,
 - (c) lead (Pb) : 120 mg/kg dry matter,
 - (d) mercury (Hg) : 1 mg/kg dry matter,
 - (e) nickel (Ni) : 50 mg/kg dry matter, and
 - (f) inorganic arsenic (As) : 40 mg/kg dry matter.
3. The copper (Cu) content in a plant biostimulant must not exceed 600 mg/kg dry matter, and the zinc (Zn) content in a plant biostimulant must not exceed 1 500 mg/kg dry matter.
4. The plant biostimulant shall have the effects that are claimed on the label for the plants specified thereon.

PFC 6(A): MICROBIAL PLANT BIOSTIMULANT

1. A microbial plant biostimulant shall consist of a micro-organism or a consortium of micro-organisms referred to in CMC 7 in Part II of Annex II.
2. Pathogens in a microbial plant biostimulant must not exceed the limits set out in the following table: **U.K.**

Micro-organisms/ their toxins, metabolites	Sampling plans		Limit
	n	c	
<i>Salmonella</i> spp.	5	0	Absence in 25 g or 25 ml
<i>Escherichia coli</i>	5	0	Absence in 1 g or 1 ml
<i>Listeria monocytogenes</i>	5	0	Absence in 25 g or 25 ml
<i>Vibrio</i> spp.	5	0	Absence in 25 g or 25 ml
<i>Shigella</i> spp.	5	0	Absence in 25 g or 25 ml
<i>Staphylococcus aureus</i>	5	0	Absence in 25 g or 25 ml
<i>Enterococcaceae</i>	5	2	10 CFU/g
Anaerobic plate count unless the microbial	5	2	10 ⁵ CFU/g or ml

Status: Point in time view as at 05/06/2019.

Changes to legislation: There are currently no known outstanding effects for the Regulation (EU) 2019/1009 of the European Parliament and of the Council. (See end of Document for details)

plant biostimulant is an aerobic bacterium			
Yeast and mould count unless the microbial plant biostimulant is a fungus	5	2	1 000 CFU/g or ml

Where:

- n = number of units comprising the sample,
c = number of sample units giving values over the defined limit.

3. When the microbial plant biostimulant is in liquid form, the plant biostimulant shall have a pH optimal for contained micro-organisms and for plants.

PFC 6(B): NON-MICROBIAL PLANT BIOSTIMULANT

1. A non-microbial plant biostimulant shall be a plant biostimulant other than a microbial plant biostimulant.
2. Pathogens in a non-microbial plant biostimulant must not exceed the limits set out in the following table: **U.K.**

Micro-organisms to be tested	Sampling plans			Limit
	n	c	m	M
<i>Salmonella</i> spp.	5	0	0	Absence in 25 g or 25 ml
<i>Escherichia coli</i> or <i>Enterococcaceae</i>	5	5	0	1 000 in 1 g or 1 ml

Where:

- n = number of samples to be tested,
c = number of samples where the number of bacteria expressed in CFU is between m and M,
m = threshold value for the number of bacteria expressed in CFU that is considered satisfactory,
M = maximum value of the number of bacteria expressed in CFU.

PFC 7: FERTILISING PRODUCT BLEND

1. A fertilising product blend shall be an EU fertilising product composed of two or more EU fertilising products of PFC 1 to PFC 6 for which the compliance with the requirements of this Regulation of each component EU fertilising product in the blend has been demonstrated in accordance with the conformity assessment procedure applicable to that component EU fertilising product.
2. The blending shall not change the nature of each component EU fertilising product and shall not have an adverse effect on human, animal or plant health, on safety, or on the environment, under reasonably foreseeable conditions of storage or use of the fertilising product blend.

Status: Point in time view as at 05/06/2019.

Changes to legislation: There are currently no known outstanding effects for the Regulation (EU) 2019/1009 of the European Parliament and of the Council. (See end of Document for details)

3. The manufacturer of the blend shall assess the conformity of the blend with the requirements set out in points 1 and 2 of this PFC, ensure the blend's compliance with the labelling requirements laid down in Annex III, and assume responsibility pursuant to Article 16(4) of this Regulation for the compliance of the blend with the requirements of this Regulation by: **U.K.**
 - (a) drawing up an EU declaration of conformity for the fertilising product blend in accordance with Article 6(2) of this Regulation, and
 - (b) being in possession of the EU declaration of conformity of each of the component EU fertilising products.
4. Economic operators making fertilising product blends available on the market shall respect the following provisions of this Regulation with regard to the EU declaration of conformity of each component EU fertilising product as well as of the blend: **U.K.**
 - (a) Article 6(3) (manufacturers' obligation to keep the EU declaration of conformity);
 - (b) point (a) of Article 7(2) (authorised representatives' obligation to keep the EU declaration of conformity);
 - (c) Article 8(8) (importers' obligation to keep a copy of the EU declaration of conformity at the disposal of the market surveillance authorities).

ANNEX II **U.K.**

Component Material Categories (CMCs)

An EU fertilising product shall consist solely of component materials complying with the requirements for one or more of the CMCs listed in this Annex.

The component materials, and the input materials used to produce them, shall not contain any of the substances for which maximum limit values are indicated in Annex I in such quantities as to jeopardise the EU fertilising product's compliance with the applicable requirements of that Annex.

PART I **U.K.**

DESIGNATION OF CMCS

CMC 1: Virgin material substances and mixtures

CMC 2: Plants, plant parts or plant extracts

CMC 3: Compost

CMC 4: Fresh crop digestate

CMC 5: Digestate other than fresh crop digestate

CMC 6: Food industry by-products

CMC 7: Micro-organisms

Status: Point in time view as at 05/06/2019.

Changes to legislation: There are currently no known outstanding effects for the Regulation (EU) 2019/1009 of the European Parliament and of the Council. (See end of Document for details)

CMC 8: Nutrient polymers

CMC 9: Polymers other than nutrient polymers

CMC 10: Derived products within the meaning of Regulation (EC) No 1069/2009

CMC 11: By-products within the meaning of Directive 2008/98/EC

PART II U.K.

REQUIREMENTS RELATED TO CMCS

This Part defines the component materials of which EU fertilising products shall solely consist.

CMC 1: VIRGIN MATERIAL SUBSTANCES AND MIXTURES

1. An EU fertilising product may contain substances and mixtures, except⁽³⁴⁾: U.K.
 - (a) waste within the meaning of Directive 2008/98/EC,
 - (b) substances or mixtures which have ceased to be waste in one or more Member States by virtue of the national measures transposing Article 6 of Directive 2008/98/EC,
 - (c) substances formed from precursors which have ceased to be waste in one or more Member States by virtue of the national measures transposing Article 6 of Directive 2008/98/EC, or mixtures containing such substances,
 - (d) by-products within the meaning of Directive 2008/98/EC,
 - (e) animal by-products or derived products within the meaning of Regulation (EC) No 1069/2009,
 - (f) polymers,
 - (g) compost, or
 - (h) digestate.
2. All substances incorporated into the EU fertilising product, on their own or in a mixture, shall have been registered pursuant to Regulation (EC) No 1907/2006⁽³⁵⁾, with a dossier containing: U.K.
 - (a) the information provided for by Annexes VI, VII and VIII to Regulation (EC) No 1907/2006, and
 - (b) a chemical safety report pursuant to Article 14 of Regulation (EC) No 1907/2006 covering the use as a fertilising product,

unless explicitly covered by one of the registration obligation exemptions provided for by Annex IV to Regulation (EC) No 1907/2006 or by points 6, 7, 8, or 9 of Annex V to that Regulation.

3. Where the substance or one of the substances in the mixture is intended to enhance the long term availability to plants of micronutrients in the EU fertilising product, that substance shall be either a chelating agent or a complexing agent, and the following rules shall apply: U.K.
 - (a) The chelating agent shall be an organic substance consisting in a molecule which:

Status: Point in time view as at 05/06/2019.

Changes to legislation: There are currently no known outstanding effects for the Regulation (EU) 2019/1009 of the European Parliament and of the Council. (See end of Document for details)

- (i) has two or more sites that donate electron pairs to a central transition metal cation (zinc (Zn), copper (Cu), iron (Fe), manganese (Mn), magnesium (Mg), calcium (Ca) or cobalt (Co)), and
- (ii) is large enough to form a five- or six- membered cyclic structure.

The EU fertilising product shall remain stable in standard Hoagland solution at pH 7 and 8 for at least 3 days.

- (b) The complexing agent shall be an organic substance forming a flat or steric structure with one di- or tri- valent transition metal cation (zinc (Zn), copper (Cu), iron (Fe), manganese (Mn) or cobalt (Co)).

The EU fertilising product shall remain stable in water solution at pH 6 and 7 for at least 1 day.

4. Where the substance or one of the substances in the mixture is intended to improve the EU fertilising product's nutrient release patterns by delaying or stopping the activity of specific groups of micro-organisms or enzymes, that substance shall be an a nitrification inhibitor, a denitrification inhibitor or a urease inhibitor, and the following rules shall apply: **U.K.**

- (a) The nitrification inhibitor shall inhibit the biological oxidation of ammoniacal nitrogen ($\text{NH}_3\text{-N}$) to nitrite nitrogen (NO_2^-), thus slowing the formation of nitrate nitrogen (NO_3^-).

The ammoniacal nitrogen ($\text{NH}_3\text{-N}$) oxidation rate shall be measured either by:

- (i) ammoniacal nitrogen ($\text{NH}_3\text{-N}$) disappearance, or
- (ii) the sum of nitrite nitrogen (NO_2^-) and nitrate nitrogen (NO_3^-) production with respect to time.

Compared to a control sample where the nitrification inhibitor has not been added, a soil sample containing the nitrification inhibitor shall show a 20 % reduction in ammoniacal nitrogen ($\text{NH}_3\text{-N}$) oxidation rate based on an analysis carried out 14 days after application at the 95 % confidence level.

At least 50 % of the total nitrogen (N) content of the EU fertilising product shall consist of the nitrogen (N) forms ammonium (NH_4^+) and urea ($\text{CH}_4\text{N}_2\text{O}$).

- (b) The denitrification inhibitor shall inhibit the formation of nitrous oxide (N_2O) by slowing down or blocking the conversion of nitrate (NO_3^-) to dinitrogen (N_2) without influencing the nitrification process as described in PFC 5(A).

Compared to a control sample where the denitrification inhibitor has not been added, an *in vitro* test containing the denitrification inhibitor shall show a 20 % reduction in rate of the release of nitrous oxide (N_2O) based on an analysis carried out 14 days after application at the 95 % confidence level.

- (c) The urease inhibitor shall inhibit hydrolytic action on urea ($\text{CH}_4\text{N}_2\text{O}$) by the urease enzyme, primarily targeted to reduce ammonia volatilisation. Compared to a control sample where the urease inhibitor has not been added, an *in vitro* test containing the urease inhibitor shall show a 20 % reduction in the rate of hydrolysis of urea ($\text{CH}_4\text{N}_2\text{O}$) based on an analysis carried out 14 days after application at the 95 % confidence level.

Status: Point in time view as at 05/06/2019.

Changes to legislation: There are currently no known outstanding effects for the Regulation (EU) 2019/1009 of the European Parliament and of the Council. (See end of Document for details)

At least 50 % of the total nitrogen (N) content of the EU fertilising product shall consist of the nitrogen (N) form urea (CH₄N₂O).

CMC 2: PLANTS, PLANT PARTS OR PLANT EXTRACTS

An EU fertilising product may contain plants, plant parts or plant extracts having undergone no other processing than cutting, grinding, milling, sieving, sifting, centrifugation, pressing, drying, frost treatment, freeze-drying or extraction with water or supercritical CO₂ extraction.

For the purpose of this point, plants include mushrooms and algae and exclude blue-green algae (cyanobacteria).

CMC 3: COMPOST

1. An EU fertilising product may contain compost obtained through aerobic composting of exclusively one or more of the following input materials: **U.K.**
 - (a) bio-waste within the meaning of Directive 2008/98/EC resulting from separate bio-waste collection at source;
 - (b) derived products referred to in Article 32 of Regulation (EC) No 1069/2009 for which the end point in the manufacturing chain has been determined in accordance with the third subparagraph of Article 5(2) of that Regulation;
 - (c) living or dead organisms or parts thereof, which are unprocessed or processed only by manual, mechanical or gravitational means, by dissolution in water, by flotation, by extraction with water, by steam distillation or by heating solely to remove water, or which are extracted from air by any means, except:
 - the organic fraction of mixed municipal household waste separated through mechanical, physicochemical, biological and/or manual treatment,
 - sewage sludge, industrial sludge or dredging sludge, and
 - animal by-products or derived products falling within the scope of Regulation (EC) No 1069/2009 for which no end point in the manufacturing chain has been determined in accordance with the third subparagraph of Article 5(2) of that Regulation;
 - (d) composting additives which are necessary to improve the process performance or the environmental performance of the composting process provided that:
 - (i) the additive is registered pursuant to Regulation (EC) No 1907/2006⁽³⁶⁾, with a dossier containing:
 - the information provided for by Annexes VI, VII and VIII to Regulation (EC) No 1907/2006, and
 - a chemical safety report pursuant to Article 14 of Regulation (EC) No 1907/2006 covering the use as a fertilising product,
 unless explicitly covered by one of the registration obligation exemptions provided for by Annex IV to Regulation (EC) No 1907/2006 or by point 6, 7, 8 or 9 of Annex V to that Regulation, and
 - (ii) the total concentration of all additives does not exceed 5 % of the total input material weight; or
 - (e) any material listed in points (a), (b) or (c) which:
 - (i) has previously been composted or digested, and
 - (ii) contains no more than 6 mg/kg dry matter of PAH₁₆⁽³⁷⁾.

Status: Point in time view as at 05/06/2019.

Changes to legislation: There are currently no known outstanding effects for the Regulation (EU) 2019/1009 of the European Parliament and of the Council. (See end of Document for details)

2. The composting shall take place in a plant: **U.K.**
 - (a) in which production lines for the processing of input materials referred to in point 1 are clearly separated from production lines for the processing of input materials other than those referred to in point 1, and
 - (b) where physical contacts between input and output materials are avoided, including during storage.
3. The aerobic composting shall consist of controlled decomposition of biodegradable materials, which is predominantly aerobic and which allows the development of temperatures suitable for thermophilic bacteria as a result of biologically produced heat. All parts of each batch shall be either regularly and thoroughly moved and turned or subject to forced ventilation in order to ensure the correct sanitation and homogeneity of the material. During the composting process, all parts of each batch shall have one of the following temperature-time profiles: **U.K.**
 - 70 °C or more for at least 3 days,
 - 65 °C or more for at least 5 days,
 - 60 °C or more for at least 7 days, or
 - 55 °C or more for at least 14 days.
4. The compost shall contain: **U.K.**
 - (a) no more than 6 mg/kg dry matter of PAH₁₆⁽³⁸⁾;
 - (b) no more than 3 g/kg dry matter of macroscopic impurities above 2 mm in any of the following forms: glass, metal or plastics; and
 - (c) no more than 5 g/kg dry matter of the sum of the macroscopic impurities referred to in point (b).

From 16 July 2026, the presence of plastics above 2 mm within the maximum limit value referred to in point (b) shall be no more than 2,5 g/kg dry matter. By 16 July 2029 the limit-value of 2,5 g/kg dry matter for plastics above 2 mm shall be re-assessed in order to take into account the progress made with regards to separate collection of bio-waste.

5. The compost shall meet at least one of the following stability criteria: **U.K.**
 - (a) Oxygen uptake rate:
 - Definition: an indicator of the extent to which biodegradable organic matter is being broken down within a specified time period. The method is not suitable for material with a content of particle sizes > 10 mm that exceeds 20 %,
 - Criterion: maximum 25 mmol O₂/kg organic matter/h; or
 - (b) Self heating factor:
 - Definition: the maximum temperature reached by a compost in standardised conditions as an indicator of the state of its aerobic biological activity,
 - Criterion: minimum Rottegrad III.

CMC 4: FRESH CROP DIGESTATE

1. An EU fertilising product may contain digestate obtained through anaerobic digestion of exclusively one or more of the following input materials: **U.K.**

Status: Point in time view as at 05/06/2019.

Changes to legislation: There are currently no known outstanding effects for the Regulation (EU) 2019/1009 of the European Parliament and of the Council. (See end of Document for details)

- (a) plants or plant parts grown for the production of biogas. For the purpose of this point, plants include algae and exclude blue-green algae (cyanobacteria);
 - (b) digestion additives which are needed to improve the process performance or the environmental performance of the digestion process provided that:
 - (i) the additive is registered pursuant to Regulation (EC) No 1907/2006⁽³⁹⁾, with a dossier containing:
 - the information provided for by Annexes VI, VII and VIII to Regulation (EC) No 1907/2006, and
 - a chemical safety report pursuant to Article 14 of Regulation (EC) No 1907/2006 covering the use as a fertilising product,
 unless explicitly covered by one of the registration obligation exemptions provided for by Annex IV to Regulation (EC) No 1907/2006 or by point 6, 7, 8 or 9 of Annex V to that Regulation, and
 - (ii) the total concentration of all additives does not exceed 5 % of the total input material weight; or
 - (c) any material referred to in point (a) that has previously been digested.
2. The anaerobic digestion shall take place in a plant: **U.K.**
- (a) in which production lines for the processing of input materials referred to in point 1 are clearly separated from production lines for the processing of input materials other than those referred to in point 1, and
 - (b) where physical contacts between input and output materials are avoided, including during storage.
3. The anaerobic digestion shall consist of controlled decomposition of biodegradable materials, which is predominantly anaerobic and at temperatures suitable for mesophilic or thermophilic bacteria. All parts of each batch shall be regularly and thoroughly moved and turned in order to ensure the correct sanitation and homogeneity of the material. During the digestion process, all parts of each batch shall have one of the following temperature-time profiles: **U.K.**
- (a) thermophilic anaerobic digestion at 55 °C for at least 24 hours followed by a hydraulic retention time of at least 20 days;
 - (b) thermophilic anaerobic digestion at 55 °C with a treatment process including pasteurisation as described in point 1 of Section 1 of Chapter I of Annex V to Commission Regulation (EU) No 142/2011⁽⁴⁰⁾;
 - (c) thermophilic anaerobic digestion at 55 °C followed by composting in:
 - 70 °C or more for at least 3 days,
 - 65 °C or more for at least 5 days,
 - 60 °C or more for at least 7 days, or
 - 55 °C or more for at least 14 days;
 - (d) mesophilic anaerobic digestion at 37-40 °C with a treatment process including pasteurisation as described in point 1 of Section 1 of Chapter I of Annex V to Regulation (EU) No 142/2011; or
 - (e) mesophilic anaerobic digestion at 37-40 °C followed by composting in:

Status: Point in time view as at 05/06/2019.

Changes to legislation: There are currently no known outstanding effects for the Regulation (EU) 2019/1009 of the European Parliament and of the Council. (See end of Document for details)

- 70 °C or more for at least 3 days,
 - 65 °C or more for at least 5 days,
 - 60 °C or more for at least 7 days, or
 - 55 °C or more for at least 14 days.
4. Both the solid and the liquid part of the digestate shall meet at least one of the following stability criteria: **U.K.**
- (a) Oxygen uptake rate:
- Definition: an indicator of the extent to which biodegradable organic matter is being broken down within a specified time period. The method is not suitable for material with a content of particle sizes > 10 mm that exceeds 20 %;
 - Criterion: maximum 25 mmol O₂/kg organic matter/h; or
- (b) Residual biogas potential:
- Definition: an indicator of the gas released from a digestate in a 28 day period and measured against the volatile solids contained within the sample. The test is run in triplicate, and the average result is used to demonstrate compliance with the criterion. The volatile solids are those solids in a sample of material that are lost on ignition of the dry solids at 550 °C;
 - Criterion: maximum 0,25 l biogas/g volatile solids.
- CMC 5: DIGESTATE OTHER THAN FRESH CROP DIGESTATE
1. An EU fertilising product may contain digestate obtained through anaerobic digestion of exclusively one or more of the following input materials: **U.K.**
- (a) bio-waste within the meaning of Directive 2008/98/EC resulting from separate bio-waste collection at source;
- (b) derived products referred to in Article 32 of Regulation (EC) No 1069/2009 for which the end point in the manufacturing chain has been determined in accordance with the third subparagraph of Article 5(2) of that Regulation;
- (c) living or dead organisms or parts thereof which are unprocessed or processed only by manual, mechanical or gravitational means, by dissolution in water, by flotation, by extraction with water, by steam distillation or by heating solely to remove water, or which are extracted from air by any means, except:
- (i) the organic fraction of mixed municipal household waste separated through mechanical, physicochemical, biological and/or manual treatment,
 - (ii) sewage sludge, industrial sludge or dredging sludge,
 - (iii) animal by-products or derived products falling within the scope of Regulation (EC) No 1069/2009 for which no end point in the manufacturing chain has been determined in accordance with the third subparagraph of Article 5(2) of that Regulation;
- (d) digestion additives which are necessary to improve the process performance or the environmental performance of the digestion process provided that:
- (i) the additive is registered pursuant to Regulation (EC) No 1907/2006⁽⁴¹⁾, with a dossier containing:

Status: Point in time view as at 05/06/2019.

Changes to legislation: There are currently no known outstanding effects for the Regulation (EU) 2019/1009 of the European Parliament and of the Council. (See end of Document for details)

- the information provided for by Annexes VI, VII and VIII to Regulation (EC) No 1907/2006, and
- a chemical safety report pursuant to Article 14 of Regulation (EC) No 1907/2006 covering the use as a fertilising product,
 - unless explicitly covered by one of the registration obligation exemptions provided for by Annex IV to Regulation (EC) No 1907/2006 or by point 6, 7, 8 or 9 of Annex V to that Regulation, and
- (ii) the total concentration of all additives does not exceed 5 % of the total input material weight; or
- (e) any material listed in points (a), (b) or (c) which:
 - (i) has previously been composted or digested, and
 - (ii) contains no more than 6 mg/kg dry matter of PAH₁₆⁽⁴²⁾.
- 2. The anaerobic digestion shall take place in a plant: **U.K.**
 - (a) in which production lines for the processing of input materials referred to in point 1 are clearly separated from production lines for the processing of input materials other than those referred to in point 1, and
 - (b) where physical contacts between input and output materials are avoided, including during storage.
- 3. The anaerobic digestion shall consist of controlled decomposition of biodegradable materials, which is predominantly anaerobic and at temperatures suitable for mesophilic or thermophilic bacteria. All parts of each batch shall be regularly and thoroughly moved and turned in order to ensure the correct sanitation and homogeneity of the material. During the digestion process, all parts of each batch shall have one of the following temperature-time profiles: **U.K.**
 - (a) thermophilic anaerobic digestion at 55 °C for at least 24 hours followed by a hydraulic retention time of at least 20 days;
 - (b) thermophilic anaerobic digestion at 55 °C with a treatment process including pasteurisation as described in point 1 of Section 1 of Chapter I of Annex V to Regulation (EU) No 142/2011;
 - (c) thermophilic anaerobic digestion at 55 °C followed by composting in:
 - 70 °C or more for at least 3 days,
 - 65 °C or more for at least 5 days,
 - 60 °C or more for at least 7 days, or
 - 55 °C or more for at least 14 days;
 - (d) mesophilic anaerobic digestion at 37-40 °C with a treatment process including pasteurisation as described in point 1 of Section 1 of Chapter I of Annex V to Regulation (EU) No 142/2011; or
 - (e) mesophilic anaerobic digestion at 37-40 °C followed by composting in:
 - 70 °C or more for at least 3 days,
 - 65 °C or more for at least 5 days,
 - 60 °C or more for at least 7 days, or
 - 55 °C or more for at least 14 days.

Status: Point in time view as at 05/06/2019.

Changes to legislation: There are currently no known outstanding effects for the Regulation (EU) 2019/1009 of the European Parliament and of the Council. (See end of Document for details)

4. Neither the solid nor the liquid part of the digestate shall contain more than 6 mg/kg dry matter of PAH₁₆⁽⁴³⁾.
5. The digestate shall contain: **U.K.**
 - (a) no more than 3 g/kg dry matter of macroscopic impurities above 2 mm in any of the following forms: glass, metal or plastics; and
 - (b) no more than 5 g/kg dry matter of the sum of the macroscopic impurities referred to in point (a).

From 16 July 2026, the presence of plastics above 2 mm within the maximum limit value referred to in point (a) shall be no more than 2,5 g/kg dry matter. By 16 July 2029 the limit-value of 2,5 g/kg dry matter for plastics above 2 mm shall be re-assessed in order to take into account the progress made with regards to separate collection of bio-waste.

6. Both the solid and the liquid part of the digestate shall meet at least one of the following stability criteria: **U.K.**
 - (a) Oxygen uptake rate:
 - Definition: an indicator of the extent to which biodegradable organic matter is being broken down within a specified time period. The method is not suitable for material with a content of particle sizes > 10 mm that exceeds 20 %.
 - Criterion: maximum 25 mmol O₂/kg organic matter/h; or
 - (b) Residual biogas potential:
 - Definition: an indicator of the gas released from a digestate in a 28 day period and measured against the volatile solids contained within the sample. The test is run in triplicate, and the average result is used to demonstrate compliance with the criterion. The volatile solids are those solids in a sample of material that are lost on ignition of the dry solids at 550 °C.
 - Criterion: maximum 0,25 l biogas/g volatile solids.

CMC 6: FOOD INDUSTRY BY-PRODUCTS

1. An EU fertilising product may contain component material consisting of one of the following substances: **U.K.**
 - (a) food industry factory lime, i.e. a material from the food processing industry obtained by carbonation of organic matter, using exclusively burnt lime from natural sources;
 - (b) molasses, i.e. a viscous by-product of the refining of sugarcane or sugar beets into sugar;
 - (c) vinasse, i.e. a viscous by-product of the fermentation process of molasses into ethanol, ascorbic acid or other products;
 - (d) distillers grains, i.e. by-products resulting from the production of alcoholic beverages;
 - (e) plants, plant parts or plant extracts having undergone only heat treatment or heat treatment in addition to processing methods referred to in CMC 2; or
 - (f) lime from drinking water production, i.e. residue which is released by production of drinking water from groundwater or surface water and consists, mainly, of calcium carbonate.

Status: Point in time view as at 05/06/2019.

Changes to legislation: There are currently no known outstanding effects for the Regulation (EU) 2019/1009 of the European Parliament and of the Council. (See end of Document for details)

2. All substances incorporated into the EU fertilising product, on their own or in a mixture, shall have been registered pursuant to Regulation (EC) No 1907/2006⁽⁴⁴⁾, with a dossier containing: **U.K.**
 - (a) the information provided for by Annexes VI, VII and VIII to Regulation (EC) No 1907/2006, and
 - (b) a chemical safety report pursuant to Article 14 of Regulation (EC) No 1907/2006 covering the use as a fertilising product,

unless explicitly covered by one of the registration obligation exemptions provided for by Annex IV to Regulation (EC) No 1907/2006 or by point 6, 7, 8, or 9 of Annex V to that Regulation.

CMC 7: MICRO-ORGANISMS

An EU fertilising product belonging to PFC 6(A) may contain micro-organisms, including dead or empty-cell micro-organisms and non-harmful residual elements of the media on which they were produced, which:

- have undergone no other processing than drying or freeze-drying; and
- are listed in the following table:

Azotobacter spp.

Mycorrhizal fungi

Rhizobium spp.

Azospirillum spp.

CMC 8: NUTRIENT POLYMERS

1. An EU fertilising product may contain polymers exclusively made up of monomer substances complying with the criteria set out in points 1 and 2 of CMC 1, where the purpose of the polymerisation is to control the release of nutrients from one or more of the monomer substances.
2. At least 60 % of the polymers shall be soluble in a phosphate buffer solution with a pH of 7,5 at 100 °C.
3. The final degradation products shall be only ammonia (NH₃), water and carbon dioxide (CO₂).
4. The polymers shall not contain more than 600 ppm of free formaldehyde.

CMC 9: POLYMERS OTHER THAN NUTRIENT POLYMERS

1. An EU fertilising product may contain polymers other than nutrient polymers only in cases where the purpose of the polymer is: **U.K.**
 - (a) to control the water penetration into nutrient particles and thus the release of nutrients (in which case the polymer is commonly referred to as a ‘coating agent’),
 - (b) to increase the water retention capacity or wettability of the EU fertilising product, or
 - (c) to bind material in an EU fertilising product belonging to PFC 4.
2. From 16 July 2026, the polymers referred to in point 1(a) and (b) shall comply with the biodegradability criteria established by delegated acts referred to in Article 42(6).

Status: Point in time view as at 05/06/2019.

Changes to legislation: There are currently no known outstanding effects for the Regulation (EU) 2019/1009 of the European Parliament and of the Council. (See end of Document for details)

In the absence of such criteria, an EU fertilising product placed on the market after that date shall not contain such polymers.

3. For the polymers referred to in point 1(a) and (b), neither the polymer, nor its degradation by-products, shall show any overall adverse effect on animal or plant health, or on the environment, under reasonably foreseeable conditions of use in the EU fertilising product. The polymer shall pass a plant growth acute toxicity test, an earthworm acute toxicity test and a nitrification inhibition test with soil micro-organisms as follows: **U.K.**

- (a) In the plant growth acute toxicity test, the germination rate and the plant biomass of the tested plant species grown on the soil exposed to the test material shall be more than 90 % of the germination rate and the plant biomass of the same plant species grown on corresponding blank soil not exposed to the test material.

The results shall be considered to be valid only if in the controls (i.e. blank soil):

- the seedling emergence is at least 70 %;
- the seedlings do not exhibit visible phytotoxic effects (e.g. chlorosis, necrosis, wilting, leaf and stem deformations) and the plants exhibit only normal variation in growth and morphology for that particular species;
- the mean survival of emerged control seedlings is at least 90 % for the duration of the study; and
- environmental conditions for a particular species are identical and growing media contain the same amount of soil matrix, support media, or substrate from the same source.

- (b) In the earthworm acute toxicity test, the observed mortality and the biomass of surviving earthworms in a soil exposed to the test material shall not differ by more than 10 % compared to those from the corresponding blank soil not exposed to the test material. The results shall be considered to be valid, if:

- the percent mortality observed in the control (i.e. blank soil) is less than 10 %, and
- the average loss of biomass (mean weight) of the worms in the blank soil does not exceed 20 %.

- (c) In the nitrification inhibition test with soil micro-organisms, the nitrite formation in soil exposed to the test material shall be more than 90 % of those from the corresponding blank soil not exposed to the test material. The results shall be considered to be valid, if the variation between replicate control samples (blank soil) and test samples is less than 20 %.

CMC 10: DERIVED PRODUCTS WITHIN THE MEANING OF REGULATION (EC) NO 1069/2009

An EU fertilising product may contain derived products within the meaning of Regulation (EC) No 1069/2009 having reached the end point in the manufacturing chain as determined in accordance with that Regulation, and which are listed in the following table and as specified therein⁽⁴⁵⁾:

CMC 11: BY-PRODUCTS WITHIN THE MEANING OF DIRECTIVE 2008/98/EC

1. An EU fertilising product may contain by-products within the meaning of Directive 2008/98/EC, except⁽⁴⁶⁾: **U.K.**

- (a) animal by-products or derived products within the meaning of Regulation (EC) No 1069/2009,

Status: Point in time view as at 05/06/2019.

Changes to legislation: There are currently no known outstanding effects for the Regulation (EU) 2019/1009 of the European Parliament and of the Council. (See end of Document for details)

- (b) polymers,
 - (c) compost, or
 - (d) digestate.
2. The by-products shall have been registered pursuant to Regulation (EC) No 1907/2006, with a dossier containing: **U.K.**
- (a) the information provided for by Annexes VI, VII and VIII to Regulation (EC) No 1907/2006, and
 - (b) a chemical safety report pursuant to Article 14 of Regulation (EC) No 1907/2006 covering the use as a fertilising product,

unless explicitly covered by one of the registration obligation exemptions provided for by Annex IV to Regulation (EC) No 1907/2006 or by point 6, 7, 8 or 9 of Annex V to that Regulation.

3. From 16 July 2022, the by-products shall comply with the criteria established by delegated act referred to in Article 42(7). An EU fertilising product placed on the market after that date shall not contain by-products referred to in point 1 which do not comply with such criteria.

ANNEX III **U.K.**

Labelling requirements

This Annex sets out the labelling requirements for EU fertilising products. The requirements laid down in Part II and Part III of this Annex for a given PFC, as specified in Annex I, apply to EU fertilising products in all subcategories of that PFC.

PART I **U.K.**

GENERAL LABELLING REQUIREMENTS

1. The following information shall be provided: **U.K.**
- (a) for EU fertilising products in PFC 1 to PFC 6, the designation as indicated in Part I of Annex I of the PFC corresponding to the product's claimed function;
 - (b) for EU fertilising products in PFC 7, the designations as indicated in Part I of Annex I of all the PFCs corresponding to the claimed functions of the component EU fertilising products;
 - (c) the quantity of the EU fertilising product, indicated by mass or volume;
 - (d) instructions for intended use, including application rates, timing and frequency, and target plants or mushrooms;
 - (e) recommended storage conditions;
 - (f) for products containing a polymer belonging to CMC 9 in Part II of Annex II, the time period following use during which the nutrient release is being controlled or the water retention capacity is being increased (the 'functionality period'), which shall

Status: Point in time view as at 05/06/2019.

Changes to legislation: There are currently no known outstanding effects for the Regulation (EU) 2019/1009 of the European Parliament and of the Council. (See end of Document for details)

- not be longer than the period between two applications in accordance with the use instructions referred to in point (d);
- (g) any relevant information on measures recommended to manage risks to human, animal or plant health, to safety or to the environment; and
- (h) a list of all ingredients above 5 % by product weight in descending order of magnitude by dry weight, including the designations of the relevant CMCs as referred to in Part I of Annex II to this Regulation; where the ingredient is a substance or a mixture, it shall be identified as specified in Article 18 of Regulation (EC) No 1272/2008.
2. Where the EU fertilising product has functions described in two or more of the PFCs laid down in Annex I, only those functions for which the EU fertilising product has been subject to a successful conformity assessment in accordance with this Regulation may be claimed by using the corresponding PFC designations as indicated in Part I of Annex I.
3. Where the EU fertilising product contains a substance for which maximum residue limits for food and feed have been established in accordance with Regulation (EEC) No 315/93, Regulation (EC) No 396/2005, Regulation (EC) No 470/2009 or Directive 2002/32/EC, the instructions referred to in point 1(d) shall ensure that the intended use of the EU fertilising product does not lead to the exceedance of those limits in food or feed.
4. Where the EU fertilising product contains derived products within the meaning of Regulation (EC) No 1069/2009 other than manure, the following instruction shall be provided on the label: ‘Farmed animals shall not be fed, either directly or by grazing, with herbage from land to which the product has been applied unless the cutting or grazing takes place after the expiry of a waiting period of at least 21 days.’.
5. Where the EU fertilising product contains ricin, the following instruction shall be provided on the label: ‘Hazardous to animals in case of ingestion’.
6. Where the EU fertilising product contains unprocessed or processed cocoa shells, the following instruction shall be provided on the label: ‘Toxic to dogs and cats’.
7. Where the EU fertilising product contains a polymer with the purpose of binding material in the product, as referred to in point 1(c) of CMC 9 in Part II of Annex II, the user shall be instructed not to use the product in contact with soil, and in collaboration with the manufacturer, make sure of a sound disposal of the products after end of use.
8. Information other than the information required under points 1 to 6: **U.K.**
- (a) shall not mislead the user, for example by attributing to the product properties that it does not possess, or by suggesting that the product possesses unique characteristics which similar products also have;
- (b) shall relate to verifiable factors;
- (c) shall not make claims such as ‘sustainable’ or ‘environmentally friendly’ unless such claims refer to legislation, or clearly identified guidelines, standards or schemes, with which the EU fertilising product complies; and
- (d) shall not make claims by means of statements or visual representations that the EU fertilising product prevents or treats plant diseases or protects plants against harmful organisms.

Status: Point in time view as at 05/06/2019.

Changes to legislation: There are currently no known outstanding effects for the Regulation (EU) 2019/1009 of the European Parliament and of the Council. (See end of Document for details)

9. The phrase ‘poor in chloride’ or similar may only be used if the chloride (Cl-) content is below 30 g/kg of dry matter.
10. Where the nutrient content information requirements in this Annex are expressed in oxidised form, the nutrient content may be expressed in elemental form instead or in addition to the oxidised form in accordance with the following conversion factors: **U.K.**
- | | | |
|----------------|---|--|
| phosphorus (P) | = | phosphorus pentoxide (P ₂ O ₅) × 0,436; |
| potassium (K) | = | potassium oxide (K ₂ O) × 0,830; |
| calcium (Ca) | = | calcium oxide (CaO) × 0,715; |
| magnesium (Mg) | = | magnesium oxide (MgO) × 0,603; |
| sodium (Na) | = | sodium oxide (Na ₂ O) × 0,742; |
| sulphur (S) | = | sulphur trioxide (SO ₃) × 0,400. |
11. Where the information requirements in this Annex refer to organic carbon (C_{org}), the information may refer to organic matter instead of or in addition to organic carbon (C_{org}), in accordance with the following conversion factor: **U.K.**
- organic carbon (C_{org}) = organic matter × 0,56.

PART II **U.K.**

PRODUCT-SPECIFIC LABELLING REQUIREMENTS

PFC 1: FERTILISER

- The content of nutrients may be declared only where they are present in the EU fertilising product in the minimum quantity specified in Annex I for the relevant PFC.
- If nitrogen (N) or phosphorus (P) are not declared nutrients, the content of nitrogen (N) or phosphorus pentoxide (P₂O₅) shall nevertheless be indicated if above 0,5 % by mass. That indication shall be separate from the nutrient declaration.
- The following rules apply to fertilisers containing inhibitors, as specified in CMC 1 in Part II of Annex II: **U.K.**
 - the label shall state the words ‘nitrification inhibitor’, ‘denitrification inhibitor’ or ‘urease inhibitor’, as relevant;
 - the nitrification inhibitor content shall be expressed as a % by mass of the total nitrogen (N) present as ammonium nitrogen (NH₄⁺) and urea nitrogen (CH₄N₂O);
 - the denitrification inhibitor content shall be expressed as a % by mass of the nitrate (NO₃⁻) present;
 - the urease inhibitor content shall be expressed as a % by mass of the total nitrogen (N) present as urea nitrogen (CH₄N₂O).
- The term ‘mineral fertiliser’ may be used only if the fertiliser belongs to PFC 1(C) and fulfils the following additional conditions: **U.K.**
 - the mineral fertiliser must not contain more than 1 % by mass of organic carbon (C_{org}), other than organic carbon from:

Status: Point in time view as at 05/06/2019.

Changes to legislation: There are currently no known outstanding effects for the Regulation (EU) 2019/1009 of the European Parliament and of the Council. (See end of Document for details)

- (i) chelating or complexing agents referred to in point 3 of CMC 1 in Part II of Annex II,
 - (ii) nitrification inhibitors, denitrification inhibitors or urease inhibitors referred to in point 4 of CMC 1 in Part II of Annex II,
 - (iii) coating agents referred to in point 1(a) of CMC 9 in Part II of Annex II,
 - (iv) urea ($\text{CH}_4\text{N}_2\text{O}$), or
 - (v) calcium cyanamide (CaCN_2);
- (b) where phosphorus (P) is a declared nutrient, the declared phosphorus content shall consist only of phosphorus in the phosphatic form, and the mineral fertiliser shall fulfil at least one of the following solubility criteria:
- (i) water solubility: minimum level 40 % of total phosphorus (P),
 - (ii) solubility in neutral ammonium citrate: minimum level 75 % of total phosphorus (P), or
 - (iii) solubility in formic acid (only for soft rock phosphate): minimum level 55 % of total phosphorus (P);
- (c) where nitrogen (N) is a declared nutrient, the declared nitrogen content shall consist only of the sum of nitric nitrogen, ammoniacal nitrogen, ureic nitrogen, and nitrogen from methylene-urea, from isobutylidenediurea, and from crotonylidenediurea.

PFC 1(A): ORGANIC FERTILISER

The following information shall be provided:

- (a) the declared primary nutrients nitrogen (N), phosphorus (P) or potassium (K), by their chemical symbols in the order N-P-K;
- (b) the declared secondary nutrients calcium (Ca), magnesium (Mg), sodium (Na), or sulphur (S) by their chemical symbols in the order Ca-Mg-Na-S;
- (c) numbers indicating the content of the declared nutrients total nitrogen (N), total phosphorus in the form of phosphorus pentoxide (P_2O_5) or total potassium in the form of potassium oxide (K_2O), followed by numbers in brackets indicating the total content of calcium oxide (CaO), magnesium oxide (MgO), sodium oxide (Na_2O) or sulphur trioxide (SO_3);
- (d) the content of the following declared nutrients and other parameters, in the following order and as % by mass:
 - (i) nitrogen (N):
 - total nitrogen (N);
 - minimum amount of organic nitrogen (N_{org}), followed by a description of the origin of the organic matter used;
 - nitrogen in the form of ammoniacal nitrogen;
 - (ii) total phosphorus pentoxide (P_2O_5);
 - (iii) total potassium oxide (K_2O);

Status: Point in time view as at 05/06/2019.

Changes to legislation: There are currently no known outstanding effects for the Regulation (EU) 2019/1009 of the European Parliament and of the Council. (See end of Document for details)

- (iv) calcium oxide (CaO), magnesium oxide (MgO), sodium oxide (Na₂O) and sulphur trioxide (SO₃), expressed:
 - where those nutrients are totally soluble in water, only as the content soluble in water;
 - where the soluble content of those nutrients is at least a quarter of the total content of those nutrients, as the total content and as the content soluble in water;
 - in other cases, as the total content;
 - (v) organic carbon (C_{org});
 - (vi) dry matter;
 - (e) the ratio of organic carbon to total nitrogen (C_{org}/N);
 - (f) production date;
 - (g) the form of the physical unit of the product, such as powder or pellets, if applicable.
- PFC 1(B): ORGANO-MINERAL FERTILISER
1. The following information shall be provided: **U.K.**
 - (a) the declared primary nutrients nitrogen (N), phosphorus (P) or potassium (K), by their chemical symbols in the order N-P-K;
 - (b) where applicable, the declared secondary nutrients calcium (Ca), magnesium (Mg), sodium (Na) or sulphur (S) by their chemical symbols in the order Ca-Mg-Na-S;
 - (c) numbers indicating the content of the declared nutrients total nitrogen (N), total phosphorus in the form of phosphorus pentoxide (P₂O₅) or total potassium in the form of potassium oxide (K₂O), followed by numbers in brackets indicating the total content of calcium oxide (CaO), magnesium oxide (MgO), sodium oxide (Na₂O) or sulphur trioxide (SO₃);
 - (d) the content of the following declared nutrients and other parameters, in the following order and as % by mass:
 - (i) nitrogen (N):
 - total nitrogen (N);
 - minimum amount of organic nitrogen (N_{org}), followed by a description of the origin of the organic matter used;
 - nitrogen in the form of nitric nitrogen;
 - nitrogen in the form of ammoniacal nitrogen;
 - nitrogen in the form of urea nitrogen;
 - (ii) phosphorus pentoxide (P₂O₅):
 - total phosphorus pentoxide (P₂O₅);
 - water-soluble phosphorus pentoxide (P₂O₅);
 - phosphorus pentoxide (P₂O₅) soluble in neutral ammonium citrate;
 - where soft ground phosphate is present, phosphorus pentoxide (P₂O₅) soluble in formic acid;
 - (iii) potassium oxide (K₂O):

Status: Point in time view as at 05/06/2019.

Changes to legislation: There are currently no known outstanding effects for the Regulation (EU) 2019/1009 of the European Parliament and of the Council. (See end of Document for details)

- total potassium oxide (K₂O);
- water soluble potassium oxide (K₂O);
- (iv) calcium oxide (CaO), magnesium oxide (MgO), sodium oxide (Na₂O) and sulphur trioxide (SO₃), expressed:
 - where those nutrients are totally soluble in water, only as the content soluble in water;
 - where the soluble content of those nutrients is at least a quarter of the total content of those nutrients, as the total content and as the content soluble in water;
 - in other cases, as the total content;
- (v) organic carbon (C_{org});
- (vi) dry matter,
- (e) where urea (CH₄N₂O) is present, information about the possible air quality impacts of the release of ammonia from the fertiliser use, and an invitation to users to apply appropriate remediation measures.
- 2. Where one or more of the micronutrients boron (B), cobalt (Co), iron (Fe), manganese (Mn) and molybdenum (Mo) are present in the minimum content indicated as % by mass in the following table, they: **U.K.**
 - shall be declared if they are intentionally added to an organo-mineral fertiliser, and
 - may be declared in other cases:

Micronutrient	Content of micronutrient (% by mass)		
	Solid organo-mineral fertiliser		Liquid organo-mineral fertiliser
	Intended for use on crops or grassland	Intended for horticultural use	
Boron (B)	0,01	0,01	0,01
Cobalt (Co)	0,002	n.a.	0,002
Iron (Fe)	0,5	0,02	0,02
Manganese (Mn)	0,1	0,01	0,01
Molybdenum (Mo)	0,001	0,001	0,001

3. Where one or both of the micronutrients copper (Cu) and zinc (Zn) are present, without being intentionally added, in the minimum content indicated as % by mass in the following table, they may be declared: **U.K.**

Micronutrient	Content of micronutrient (% by mass)		
	Solid organo-mineral fertiliser		Liquid organo-mineral fertiliser
	Intended for use on crops or grassland	Intended for horticultural use	
Copper (Cu)	0,01	0,002	0,002
Zinc (Zn)	0,01	0,002	0,002

Status: Point in time view as at 05/06/2019.

Changes to legislation: There are currently no known outstanding effects for the Regulation (EU) 2019/1009 of the European Parliament and of the Council. (See end of Document for details)

4. Where copper (Cu) or zinc (Zn) is intentionally added to the organo-mineral fertiliser, the total content of copper (Cu) or zinc (Zn) shall be declared.
5. The micronutrients referred to in points 2, 3 and 4 shall be declared after the information on macronutrients. The following information shall be provided: **U.K.**
 - (a) indication of the names and chemical symbols of the declared micronutrients, listed in the following order: boron (B), cobalt (Co), copper (Cu), iron (Fe), manganese (Mn), molybdenum (Mo) and zinc (Zn), followed by the names of their counter-ions;
 - (b) the total micronutrient content expressed as % by mass:
 - where those micronutrients are totally soluble in water, only as the content soluble in water;
 - where the soluble content of those micronutrients is at least a quarter of the total content of those micronutrients, as the total content and as the content soluble in water;
 - in other cases, as the total content;
 - (c) where the declared micronutrients are chelated by chelating agents, the following qualifier after the name and the chemical identifier of the micronutrient:
 - ‘chelated by ... (name of the chelating agent or its abbreviation)’, and the amount of chelated micronutrient as % by mass;
 - (d) where the organo-mineral fertiliser contains micronutrients complexed by complexing agents the following qualifier after the name and the chemical identifier of the micronutrient:
 - ‘complexed by ... (name of the complexing agent or its abbreviation)’, and the amount of complexed micronutrient as % by mass;
 - (e) where micronutrients are intentionally added, the following statement: ‘To be used only where there is a recognised need. Do not exceed the application rate’.
6. Where an organo-mineral fertiliser has a cadmium (Cd) content equal to or lower than 20 mg/kg phosphorus pentoxide (P₂O₅), the statement ‘Low cadmium (Cd) content’ or similar, or a visual representation to that effect, may be added.

PFC 1(C): INORGANIC FERTILISER

PFC 1(C)(I): INORGANIC MACRONUTRIENT FERTILISER

1. The following information shall be provided: **U.K.**
 - (a) where applicable, the declared primary nutrients nitrogen (N), phosphorus (P) or potassium (K), by their chemical symbols in the order N-P-K;
 - (b) where applicable, the declared secondary nutrients calcium (Ca), magnesium (Mg), sodium (Na) or sulphur (S) by their chemical symbols in the order Ca-Mg-Na-S;
 - (c) numbers indicating the content of the declared nutrients total nitrogen (N), total phosphorus in the form of phosphorus pentoxide (P₂O₅) or total potassium in the form of potassium oxide (K₂O), followed by numbers in brackets indicating the total content of calcium oxide (CaO), magnesium oxide (MgO), sodium oxide (Na₂O) or sulphur trioxide (SO₃);
 - (d) the content of the following declared nutrients, in the following order and as % by mass:

Status: Point in time view as at 05/06/2019.

Changes to legislation: There are currently no known outstanding effects for the Regulation (EU) 2019/1009 of the European Parliament and of the Council. (See end of Document for details)

- (i) nitrogen (N):
 - total nitrogen (N);
 - nitrogen in the form of nitric nitrogen;
 - nitrogen in the form of ammoniacal nitrogen;
 - nitrogen in the form of urea nitrogen;
 - nitrogen from urea formaldehyde, isobutylidenediurea, crotonylidenediurea;
 - nitrogen from cyanamide nitrogen;
 - (ii) phosphorus pentoxide (P₂O₅):
 - total phosphorus pentoxide (P₂O₅);
 - water-soluble phosphorus pentoxide (P₂O₅);
 - phosphorus pentoxide (P₂O₅) soluble in neutral ammonium citrate;
 - where soft ground phosphate is present, phosphorus pentoxide (P₂O₅) soluble in formic acid;
 - (iii) water soluble potassium oxide (K₂O);
 - (iv) calcium oxide (CaO), magnesium oxide (MgO), sodium oxide (Na₂O) and sulphur trioxide (SO₃), expressed:
 - where those nutrients are totally soluble in water, only as the content soluble in water;
 - where the soluble content of those nutrients is at least a quarter of the total content of those nutrients, as the total content and as the content soluble in water;
 - in other cases, as the total content;
- (e) where urea (CH₄N₂O) is present, information about the possible air quality impacts of the release of ammonia from the fertiliser use, and an invitation to users to apply appropriate remediation measures.
2. Where an inorganic macronutrient fertiliser has a cadmium (Cd) content equal to or lower than 20 mg/kg phosphorous pentoxide (P₂O₅), the statement ‘Low cadmium (Cd) content’ or similar, or a visual representation to that effect, may be added.
- PFC 1(C)(I)(a): SOLID INORGANIC MACRONUTRIENT FERTILISER**
1. A solid inorganic macronutrient fertiliser may be labelled ‘complex’ only if each physical unit contains all the declared nutrients in their declared content.
 2. The granulometry of a solid inorganic macronutrient fertiliser shall be indicated, expressed as % by mass of the product passing through a determined sieve.
 3. The form of the physical unit of the product shall be indicated with one of the following mentions: **U.K.**
 - (a) granules,
 - (b) pellets,
 - (c) powder, where at least 90 % by mass of the product can pass through a sieve with a mesh of 1 mm, or
 - (d) prills.

Status: Point in time view as at 05/06/2019.

Changes to legislation: There are currently no known outstanding effects for the Regulation (EU) 2019/1009 of the European Parliament and of the Council. (See end of Document for details)

4. For coated solid inorganic macronutrient fertilisers, the name of the coating agents and the percentage of fertiliser coated by each coating agent shall be indicated and followed by: **U.K.**
- (a) for polymer coated solid inorganic macronutrient fertilisers, the following marking: ‘The rate of nutrient releases can vary according to the temperature of the substrate. An adjustment of fertilisation may be necessary’; and
- (b) for sulphur (S) coated solid inorganic macronutrient fertilisers and sulphur (S)/polymer coated solid inorganic macronutrient fertilisers, the following marking: ‘The rate of nutrient release can vary according to the temperature of the substrate and the biological activity. An adjustment of fertilisation may be necessary’.
5. Where one or more of the micronutrients boron (B), cobalt (Co), iron (Fe), manganese (Mn) and molybdenum (Mo) are present in the minimum content indicated in the following table as % by mass, they: **U.K.**
- shall be declared if they are intentionally added to the solid inorganic macronutrient fertiliser, and
- may be declared in other cases:

Micronutrient	Content of micronutrients (% by mass)	
	Intended for use on crops or grassland	Intended for horticultural use
Boron (B)	0,01	0,01
Cobalt (Co)	0,002	n.a.
Iron (Fe)	0,5	0,02
Manganese (Mn)	0,1	0,01
Molybdenum (Mo)	0,001	0,001

6. Where one or both of the micronutrients copper (Cu) and zinc (Zn) are present, without being intentionally added, in the minimum content indicated as % by mass in the following table, they may be declared: **U.K.**

Micronutrient	Content of micronutrients (% by mass)	
	Intended for use on crops or grassland	Intended for horticultural use
Copper (Cu)	0,01	0,002
Zinc (Zn)	0,01	0,002

7. Where copper (Cu) or zinc (Zn) is intentionally added to the solid inorganic macronutrient fertiliser the total content of copper (Cu) or zinc (Zn) shall be declared.
8. The micronutrients referred to in points 5, 6 and 7 shall be declared after the information on macronutrients. The following information shall be provided: **U.K.**
- (a) indication of the names and chemical symbols of the declared micronutrients, listed in the following order: boron (B), cobalt (Co), copper (Cu), iron (Fe), manganese (Mn), molybdenum (Mo) and zinc (Zn), followed by the names of their counter-ions;

Status: Point in time view as at 05/06/2019.

Changes to legislation: There are currently no known outstanding effects for the Regulation (EU) 2019/1009 of the European Parliament and of the Council. (See end of Document for details)

- (b) the total micronutrient content expressed as % by mass:
- where those micronutrients are totally soluble in water, only as the content soluble in water;
 - where the soluble content of those micronutrients is at least a quarter of the total content of those micronutrients, as the total content and as the content soluble in water;
 - in other cases, as the total content;
- (c) where the declared micronutrients are chelated by chelating agents, the following qualifier after the name and the chemical identifier of the micronutrient:
- ‘chelated by ... (name of the chelating agent or its abbreviation)’, and the amount of chelated micronutrient as % by mass;
- (d) where the solid inorganic macronutrient fertiliser contains micronutrients complexed by complexing agents the following qualifier after the name and the chemical identifier of the micronutrient:
- ‘complexed by ... (name of the complexing agent or its abbreviation)’, and the amount of complexed micronutrient as % by mass;
- (e) where micronutrients are intentionally added, the following statement: ‘To be used only where there is a recognised need. Do not exceed the application rate’.

PFC 1(C)(I)(b): LIQUID INORGANIC MACRONUTRIENT FERTILISER

1. The label shall indicate whether the liquid inorganic macronutrient fertiliser is in suspension or in solution.
2. The nutrient content may be indicated as % by mass or volume.
3. Where one or more of the micronutrients boron (B), cobalt (Co), iron (Fe), manganese (Mn) and molybdenum (Mo) are present in the minimum content indicated in the following table as % by mass, they: **U.K.**
 - shall be declared if they are intentionally added to the liquid inorganic macronutrient fertiliser, and
 - may be declared in other cases:

Micronutrient	Content of micronutrient (% by mass)
Boron (B)	0,01
Cobalt (Co)	0,002
Iron (Fe)	0,02
Manganese (Mn)	0,01
Molybdenum (Mo)	0,001

4. Where one or both of the micronutrients copper (Cu) and zinc (Zn) are present, without being intentionally added, by at least 0,002 % by mass, they may be declared.
5. Where copper (Cu) or zinc (Zn) is intentionally added to the liquid inorganic macronutrient fertiliser the total content of copper (Cu) or zinc (Zn) shall be declared.
6. The micronutrients referred to in points 3, 4 and 5 shall be declared after the information on macronutrients. The following information shall be provided: **U.K.**

Status: Point in time view as at 05/06/2019.

Changes to legislation: There are currently no known outstanding effects for the Regulation (EU) 2019/1009 of the European Parliament and of the Council. (See end of Document for details)

- (a) indication of the names and chemical symbols of the declared micronutrients, listed in the following order: boron (B), cobalt (Co), copper (Cu), iron (Fe), manganese (Mn), molybdenum (Mo) and zinc (Zn), followed by the names of their counter-ions;
- (b) the total micronutrient content expressed as % by mass or volume:
- where those micronutrients are totally soluble in water, only as the content soluble in water;
 - where the soluble content of those micronutrients is at least a quarter of the total content of those micronutrients, as the total content and as the content soluble in water;
 - in other cases, as the total content;
- (c) where the declared micronutrients are chelated by chelating agents, the following qualifier after the name and the chemical identifier of the micronutrient:
- ‘chelated by ... (name of the chelating agent or its abbreviation)’, and the amount of chelated micronutrient as % by mass;
- (d) where the liquid inorganic macronutrient fertiliser contains micronutrients complexed by complexing agents the following qualifier after the name and the chemical identifier of the micronutrient:
- ‘complexed by ... (name of the complexing agent or its abbreviation)’, and the amount of complexed micronutrient as % by mass;
- (e) where micronutrients are intentionally added, the following statement: ‘To be used only where there is a recognised need. Do not exceed the application rate’.

PFC 1(C)(II): INORGANIC MICRONUTRIENT FERTILISER

1. The declared micronutrients in the inorganic micronutrient fertiliser shall be listed by their names and chemical symbols in the following order: boron (B), cobalt (Co), copper (Cu), iron (Fe), manganese (Mn), molybdenum (Mo) and zinc (Zn), followed by the names of their counter-ions.
2. Where the declared micronutrients are chelated by chelating agents, and each chelating agent can be identified and quantified and chelates at least 1 % water-soluble micronutrient, the following qualifier shall be added after the name and the chemical identifier of the micronutrient: **U.K.**
 - ‘chelated by ... (name of the chelating agent or its abbreviation)’, and the amount of chelated micronutrient as % by mass.
3. Where the declared micronutrients are complexed by complexing agents, the following qualifier shall be added after the name and the chemical identifier of the micronutrient: **U.K.**
 - ‘complexed by ... (name of the complexing agent or its abbreviation)’, and the amount of complexed micronutrient as % by mass.
4. The following statement shall appear: ‘To be used only where there is a recognised need. Do not exceed the application rate’.

PFC 1(C)(II)(a): STRAIGHT INORGANIC MICRONUTRIENT FERTILISER

1. The label shall indicate the relevant typology, as referred to in the table under PFC 1(C)(II)(a) in Part II of Annex I.
2. The total micronutrient content shall be expressed as % by mass: **U.K.**
 - where the micronutrient is totally soluble in water, only as the content soluble in water;

Status: Point in time view as at 05/06/2019.

Changes to legislation: There are currently no known outstanding effects for the Regulation (EU) 2019/1009 of the European Parliament and of the Council. (See end of Document for details)

- where the soluble content of the micronutrient is at least a quarter of the total content of that micronutrient, as the total content and as the content soluble in water;
- in other cases, as the total content.

PFC 1(C)(II)(b): COMPOUND INORGANIC MICRONUTRIENT FERTILISER

1. Micronutrients may be declared only if they are present in the minimum content indicated in the following table as % by mass: **U.K.**

Micronutrient	Content of micronutrient (% by mass)	
	Non-chelated, non-complexed	Chelated or complexed
Boron (B)	0,2	n.a.
Cobalt (Co)	0,02	0,02
Copper (Cu)	0,5	0,1
Iron (Fe)	2	0,3
Manganese (Mn)	0,5	0,1
Molybdenum (Mo)	0,02	n.a.
Zinc (Zn)	0,5	0,1

2. If the compound inorganic micronutrient fertiliser is in suspension or in solution, the label shall indicate ‘in suspension’ or ‘in solution’, as relevant.
3. The total micronutrient content shall be expressed as % by mass: **U.K.**
 - where the micronutrients are totally soluble in water, only as the content soluble in water;
 - where the soluble content of the micronutrients is at least half of the total content of those micronutrients, as the total content and as the content soluble in water;
 - in other cases, as the total content.

PFC 2: LIMING MATERIAL

The following parameters shall be declared in the following order:

- neutralising value;
- granulometry, expressed as % by mass of product passing through a sieve of 1,0 mm;
- total calcium oxide (CaO), expressed as % by mass;
- total magnesium oxide (MgO), expressed as % by mass;
- reactivity and method of determination of reactivity, except for oxide and hydroxide limes.

PFC 3: SOIL IMPROVER

1. The dry matter content expressed as % by mass shall be declared.
2. The following nutrients expressed as % by mass shall be declared, if exceeding 0,5 % by mass: nitrogen (N), phosphorus pentoxide (P₂O₅) and potassium oxide (K₂O).

PFC 3(A): ORGANIC SOIL IMPROVER

The following parameters shall be declared:

- pH;
- electrical conductivity, given as mS/m;

Status: Point in time view as at 05/06/2019.

Changes to legislation: There are currently no known outstanding effects for the Regulation (EU) 2019/1009 of the European Parliament and of the Council. (See end of Document for details)

- organic carbon (C_{org}) content, expressed as % by mass;
- minimum amount of organic nitrogen (N_{org}), expressed as % by mass, followed by a description of the origin of the organic matter used;
- the ratio of organic carbon to total nitrogen (C_{org}/N).

PFC 4: GROWING MEDIUM

The following parameters shall be declared in the following order:

- electrical conductivity given as mS/m, except for mineral wool;
- pH;
- quantity:
 - for mineral wool, expressed as number of pieces and the three dimensions length, height, and width;
 - for other pre-shaped growing media, expressed as size in at least two dimensions;
 - for other growing media, expressed as total volume;
 - except for pre-shaped growing media, quantity expressed as volume of materials with a particle size greater than 60 mm, when present;
- nitrogen (N) extractable by $\text{CaCl}_2/\text{DTPA}$ (calcium chloride/diethylenetriaminepentaacetic acid; 'CAT-soluble'), if above 150 mg/l;
- phosphorus pentoxide (P_2O_5) extractable by $\text{CaCl}_2/\text{DTPA}$ (calcium chloride/diethylenetriaminepentaacetic acid; 'CAT-soluble'), if above 20 mg/l;
- potassium oxide (K_2O) extractable by $\text{CaCl}_2/\text{DTPA}$ (calcium chloride/diethylenetriaminepentaacetic acid; 'CAT-soluble'), if above 150 mg/l;
- production date.

PFC 5: INHIBITOR

All ingredients shall be declared by product weight or volume in descending order of magnitude.

PFC 6: PLANT BIOSTIMULANT

The following information shall be provided:

- (a) physical form;
- (b) production and expiry date;
- (c) application method(s);
- (d) effect claimed for each target plant; and
- (e) any relevant instructions related to the efficacy of the product, including soil management practices, chemical fertilisation, incompatibility with plant protection products, recommended spraying nozzles size, sprayer pressure and other anti-drift measures.

PFC 6(A): MICROBIAL PLANT BIOSTIMULANT

All intentionally added micro-organisms shall be indicated. Where the micro-organism has several strains, the intentionally added strains shall be indicated. Their concentration shall be expressed as the number of active units per volume or weight, or in any other manner that is relevant to the micro-organism, e.g. colony forming units per gram (cfu/g).

The label shall contain the following phrase: 'Micro-organisms may have the potential to provoke sensitising reactions'.

PFC 7: FERTILISING PRODUCT BLEND

Status: Point in time view as at 05/06/2019.

Changes to legislation: There are currently no known outstanding effects for the Regulation (EU) 2019/1009 of the European Parliament and of the Council. (See end of Document for details)

All the labelling requirements applicable to all component EU fertilising products apply to the fertilising product blend, and shall be expressed in relation to the final fertilising product blend.

Where the fertilising product blend contains one or more plant biostimulants belonging to PFC 6, the concentration of each plant biostimulant in the blend shall be indicated in g/kg or g/l at 20 °C.

PART III U.K.

TOLERANCE RULES

1. The declared nutrient content or physico-chemical characteristics of an EU fertilising product may deviate from the actual value only in accordance with the tolerances established in this Part for the relevant PFC. The tolerances are intended to allow for deviations in manufacture, in the distribution chain, and during sampling and analysis.
2. The tolerances allowed in respect of the declared parameters indicated in this Part are negative and positive values.
3. By derogation from point 1, the actual content of a component, in an EU fertilising product, for which a minimum or a maximum content is specified in Annex I or Annex II may never be lower than the minimum content or exceed the maximum content.

PFC 1: FERTILISER

The following tolerance rules apply to fertilisers containing nitrification inhibitors, denitrification inhibitors or urease inhibitors, as specified in CMC 1 in Part II of Annex II:

Inhibitors	Permissible tolerance for the declared content of inhibitors
Concentration below or equal to 2 %	± 20 % of the declared value
Concentration of more than 2 %	± 0,3 percentage points in absolute terms

PFC 1(A): ORGANIC FERTILISER

Forms of the declared nutrient and other declared parameters	Permissible tolerance for the declared nutrient content and other declared parameters
Organic carbon (C _{org})	± 20 % relative deviation of the declared value up to a maximum of 2,0 percentage points in absolute terms
Dry matter content	± 5,0 percentage points in absolute terms
Total nitrogen (N)	± 50 % relative deviation of the declared value up to a maximum of 1,0 percentage point in absolute terms
Organic nitrogen (N _{org})	± 50 % relative deviation of the declared value up to a maximum of 1,0 percentage point in absolute terms

Status: Point in time view as at 05/06/2019.

Changes to legislation: There are currently no known outstanding effects for the Regulation (EU) 2019/1009 of the European Parliament and of the Council. (See end of Document for details)

Total phosphorus pentoxide (P ₂ O ₅)	± 50 % relative deviation of the declared value up to a maximum of 1,0 percentage point in absolute terms
Total potassium oxide (K ₂ O)	± 50 % relative deviation of the declared value up to a maximum of 1,0 percentage point in absolute terms
Total and water-soluble magnesium oxide (MgO), calcium oxide (CaO), sulphur trioxide(SO ₃) or sodium oxide (Na ₂ O)	± 25 % of the declared content of those nutrients up to a maximum of 1,5 percentage points in absolute terms
Organic carbon (C _{org})/total nitrogen (N)	± 20 % relative deviation of the declared value up to a maximum of 2,0 percentage points in absolute terms
Quantity	± 1,5 % relative deviation of the declared value

PFC 1(B): ORGANO-MINERAL FERTILISER

Forms of the declared nutrient and other declared parameters	Permissible tolerance for the declared macronutrient content and other declared parameters
Organic carbon (C _{org})	± 20 % relative deviation of the declared value up to a maximum of 2,0 percentage points in absolute terms
Dry matter content	± 5,0 percentage points in absolute terms
Declared forms of inorganic nitrogen (N)	± 25 % relative deviation of the declared value up to a maximum of 2,0 percentage points in absolute terms
Organic nitrogen (N _{org})	± 50 % relative deviation of the declared value up to a maximum of 1,0 percentage point in absolute terms
Declared forms of phosphorus pentoxide (P ₂ O ₅)	± 25 % relative deviation of the declared value up to a maximum of 1,5 percentage points in absolute terms
Declared forms of potassium oxide (K ₂ O)	± 25 % relative deviation of the declared value up to a maximum of 1,5 percentage points in absolute terms
Total and water-soluble magnesium oxide (MgO), calcium oxide (CaO), sulphur trioxide (SO ₃)	± 25 % of the declared content of those nutrients up to a maximum of 1,0 percentage point in absolute terms
Total and water-soluble sodium oxide (Na ₂ O)	± 25 % of the declared content up to a maximum of 0,9 percentage point in absolute terms
Quantity	± 1,5 % relative deviation of the declared value

Status: Point in time view as at 05/06/2019.

Changes to legislation: There are currently no known outstanding effects for the Regulation (EU) 2019/1009 of the European Parliament and of the Council. (See end of Document for details)

Micronutrient	Permissible tolerance for the declared content of forms of micronutrient
Concentration below or equal to 2 %	± 20 % of the declared value
Concentration of more than 2 % and below or equal to 10 %	± 20 % of the declared value up to a maximum of 1,0 percentage point in absolute terms
Concentration of more than 10 %	± 1,0 percentage point in absolute terms

PFC 1(C): INORGANIC FERTILISER

Forms of the declared nutrient and other declared parameters	Permissible tolerance for the declared macronutrient content and other declared parameters
Declared forms of nitrogen (N)	± 20 % relative deviation of the declared value up to a maximum of 1,5 percentage points in absolute terms
Declared forms of phosphorus pentoxide (P ₂ O ₅)	± 20 % relative deviation of the declared value up to a maximum of 1,5 percentage points in absolute terms
Declared forms of potassium oxide (K ₂ O)	± 20 % relative deviation of the declared value up to a maximum of 1,5 percentage points in absolute terms
Declared forms of nitrogen (N), phosphorus pentoxide (P ₂ O ₅) or potassium oxide (K ₂ O) in binary fertilisers	± 1,5 percentage points in absolute terms
Declared forms of nitrogen (N), phosphorus pentoxide (P ₂ O ₅) or potassium oxide (K ₂ O) in tertiary fertilisers	± 1,9 percentage points in absolute terms
Total and water-soluble magnesium oxide (MgO), calcium oxide (CaO), sulphur trioxide (SO ₃)	± 25 % of the declared content of those nutrients up to a maximum of 1,0 percentage point in absolute terms
Total and water soluble sodium oxide (Na ₂ O)	– 25 % of the declared content up to a maximum of 0,9 percentage point in absolute terms + 50 % of the declared content up to a maximum of 1,8 percentage points in absolute terms
Granulometry	± 10 % relative deviation of the declared percentage of material passing a specific sieve
Quantity	± 1 % relative deviation of the declared value

Micronutrient	Permissible tolerance for the declared content of forms of micronutrient
Concentration below or equal to 2 %	± 20 % of the declared value

Status: Point in time view as at 05/06/2019.

Changes to legislation: There are currently no known outstanding effects for the Regulation (EU) 2019/1009 of the European Parliament and of the Council. (See end of Document for details)

Concentration of more than 2 % and below or equal to 10 %	± 20 % of the declared value up to a maximum of 1,0 percentage point in absolute terms
Concentration of more than 10 %	± 1,0 percentage point in absolute terms

Quantity: ± 5 % relative deviation of the declared value

PFC 2: LIMING MATERIAL

Forms of the declared nutrient and other declared parameters	Permissible tolerances for the declared parameter
Neutralising value	± 3
Granulometry	± 10 % relative deviation of the declared percentage of material passing a specific sieve.
Total calcium oxide (CaO)	± 3,0 percentage points in absolute terms
Total magnesium oxide (MgO)	
Concentration below 8 %	± 1,0 percentage point in absolute terms
Concentration between 8 to 16 %	± 2,0 percentage points in absolute terms
Concentration above or equal to 16 %	± 3,0 percentage points in absolute terms
Reactivities (hydrochloric acid test and incubation test)	± 5,0 percentage points in absolute terms
Quantity	± 1 % relative deviation of the declared value

PFC 3: SOIL IMPROVER

Forms of the declared nutrient and other declared parameters	Permissible tolerances for the declared parameter
pH	± 1,0 of the declared value
Organic carbon (C _{org})	± 10 % relative deviation of the declared value up to a maximum of 1,0 percentage point in absolute terms
Organic nitrogen (N _{org})	± 50 % relative deviation of the declared value up to a maximum of 1,0 percentage point in absolute terms
Total nitrogen (N)	± 20 % relative deviation up to a maximum of 1,0 percentage point in absolute terms
Total phosphorus pentoxide (P ₂ O ₅)	± 20 % relative deviation up to a maximum of 1,0 percentage point in absolute terms
Total potassium oxide (K ₂ O)	± 20 % relative deviation up to a maximum of 1,0 percentage point in absolute terms
Dry matter content	± 10 % relative deviation of the declared value

Status: Point in time view as at 05/06/2019.

Changes to legislation: There are currently no known outstanding effects for the Regulation (EU) 2019/1009 of the European Parliament and of the Council. (See end of Document for details)

Quantity	± 5 % relative deviation of the declared value
Electrical conductivity	± 75 % relative deviation of the declared value

PFC 4: GROWING MEDIUM

Forms for the declared nutrient and other declared parameters	Permissible tolerances for the declared parameter
Electrical conductivity	± 75 % relative deviation of the declared value
pH	± 1,0 of the declared value
Quantity by volume (litres or m ³)	± 5 % relative deviation of the declared value
Quantity (volume) determination of materials with particle size greater than 60 mm	± 5 % relative deviation of the declared value
Quantity (volume) determination of pre-shaped growing medium	± 5 % relative deviation of the declared value
Nitrogen (N) extractable by CaCl ₂ /DTPA (calcium chloride/diethylenetriaminepentaacetic acid; 'CAT-soluble')	± 75 % relative deviation of the declared value
Phosphorus pentoxide (P ₂ O ₅) extractable by CaCl ₂ /DTPA (calcium chloride/diethylenetriaminepentaacetic acid; 'CAT-soluble')	± 75 % relative deviation of the declared value
Potassium oxide (K ₂ O) extractable by CaCl ₂ /DTPA (calcium chloride/diethylenetriaminepentaacetic acid; 'CAT-soluble')	± 75 % relative deviation of the declared value

PFC 5: INHIBITOR

Inhibiting compound	Permissible tolerance for the declared content of inhibiting compound
Concentration below or equal to 2 %	± 20 % of the declared value
Concentration of more than 2 %	± 0,3 percentage point in absolute terms

Quantity: ± 5 % relative deviation of the declared value

PFC 6(A): MICROBIAL PLANT BIOSTIMULANT

The actual concentration(s) of micro-organisms may deviate by no more than 15 % from the declared value(s).

PFC 7: FERTILISING PRODUCT BLEND

Where the fertilising product blend contains one or more plant biostimulants belonging to PFC 6, the following tolerances shall apply for the declared concentration of each plant biostimulant:

Status: Point in time view as at 05/06/2019.

Changes to legislation: There are currently no known outstanding effects for the Regulation (EU) 2019/1009 of the European Parliament and of the Council. (See end of Document for details)

Declared concentration in g/kg or g/l at 20 °C	Permissible tolerance
Up to 25	± 15 % relative deviation
More than 25 up to 100	± 10 % relative deviation
More than 100 up to 250	± 6 % relative deviation
More than 250 up to 500	± 5 % relative deviation
More than 500	± 25 g/kg or ± 25 g/l

ANNEX IV U.K.

Conformity assessment procedures

PART I U.K.

APPLICABILITY OF CONFORMITY ASSESSMENT PROCEDURES

This Part sets out the applicability of conformity assessment procedure modules, as specified in Part II of this Annex, to EU fertilising products depending on their CMCs as specified in Annex II, and their PFCs as specified in Annex I.

1. **APPLICABILITY OF INTERNAL PRODUCTION CONTROL (MODULE A) U.K.**
 - 1.1. Module A may be used for an EU fertilising product composed solely of one or more of the following component materials: **U.K.**
 - (a) virgin material substances or mixtures as specified in CMC 1 in Part II of Annex II, except a nitrification inhibitor, a denitrification inhibitor or a urease inhibitor,
 - (b) fresh crop digestates as specified in CMC 4 in Part II of Annex II,
 - (c) food industry by-products as specified in CMC 6 in Part II of Annex II,
 - (d) micro-organisms as specified in CMC 7 in Part II of Annex II,
 - (e) nutrient polymers as specified in CMC 8 in Part II of Annex II,
 - (f) by-products within the meaning of Directive 2008/98/EC as specified in CMC 11 in Part II of Annex II.
 - 1.2. Module A may also be used for a fertilising product blend as specified in PFC 7.
 - 1.3. By derogation from points 1.1 and 1.2, Module A must not be used for: **U.K.**
 - (a) a straight or compound solid inorganic macronutrient ammonium nitrate fertiliser of high nitrogen content, as specified in PFC 1(C)(I)(a)(i-ii)(A), or a fertilising product blend as specified in PFC 7 containing 28 % or more by mass of nitrogen (N) from an EU fertilising product belonging to PFC 1(C)(I)(a)(i-ii)(A),
 - (b) an inhibitor as specified in PFC 5, or
 - (c) a plant biostimulant as specified in PFC 6.

Status: Point in time view as at 05/06/2019.

Changes to legislation: There are currently no known outstanding effects for the Regulation (EU) 2019/1009 of the European Parliament and of the Council. (See end of Document for details)

2. APPLICABILITY OF INTERNAL PRODUCTION CONTROL PLUS SUPERVISED PRODUCT TESTING (MODULE A1) U.K.

Module A1 shall be used for a straight or compound solid inorganic macronutrient ammonium nitrate fertiliser of high nitrogen content, as specified in PFC 1(C)(I)(a)(i-ii)(A), and for a fertilising product blend as specified in PFC 7 containing 28 % or more by mass of nitrogen (N) from an EU fertilising product belonging to PFC 1(C)(I)(a)(i-ii)(A).

3. APPLICABILITY OF EU-TYPE EXAMINATION (MODULE B) FOLLOWED BY CONFORMITY TO TYPE BASED ON INTERNAL PRODUCTION CONTROL (MODULE C) U.K.

3.1. Module B followed by Module C may be used for an EU fertilising product composed solely of one or more of the following component materials: U.K.

- (a) nitrification inhibitor, denitrification inhibitor or urease inhibitor as specified in CMC 1 in Part II of Annex II,
- (b) plants, plant parts or plant extracts as specified in CMC 2 in Part II of Annex II,
- (c) polymers other than nutrient polymers as specified in CMC 9 in Part II of Annex II,
- (d) derived products within the meaning of Regulation (EC) No 1069/2009 as specified in CMC 10 in Part II of Annex II,
- (e) CMCs referred to in point 1.1 of this Part.

3.2. Module B followed by Module C may also be used for: U.K.

- (a) an inhibitor as specified in PFC 5,
- (b) a plant biostimulant as specified in PFC 6, and
- (c) a fertilising product blend as specified in PFC 7.

3.3. By derogation from points 3.1 and 3.2, Module B followed by Module C must not be used for a straight or compound solid inorganic macronutrient ammonium nitrate fertiliser of high nitrogen content, as specified in PFC 1(C)(I)(a)(i-ii)(A), or a fertilising product blend as specified in PFC 7 containing 28 % or more by mass of nitrogen (N) from an EU fertilising product belonging to PFC 1(C)(I)(a)(i-ii)(A).

4. APPLICABILITY OF QUALITY ASSURANCE OF THE PRODUCTION PROCESS (MODULE D1) U.K.

4.1. Module D1 may be used for any EU fertilising product.

4.2. By derogation from point 4.1, Module D1 must not be used for a straight or compound solid inorganic macronutrient ammonium nitrate fertiliser of high nitrogen content, as specified in PFC 1(C)(I)(a)(i-ii)(A), or a fertilising product blend as specified in PFC 7 containing 28 % or more by mass of nitrogen (N) from an EU fertilising product belonging to PFC 1(C)(I)(a)(i-ii)(A).

PART II U.K.

DESCRIPTION OF CONFORMITY ASSESSMENT PROCEDURES MODULE A – INTERNAL PRODUCTION CONTROL

Status: Point in time view as at 05/06/2019.

Changes to legislation: There are currently no known outstanding effects for the Regulation (EU) 2019/1009 of the European Parliament and of the Council. (See end of Document for details)

1. Description of the module **U.K.**

Internal production control is the conformity assessment procedure whereby the manufacturer fulfils the obligations laid down under points 2, 3 and 4, and ensures and declares on his or her sole responsibility that the EU fertilising products concerned satisfy the requirements of this Regulation that apply to them.

2. Technical documentation **U.K.**

2.1. The manufacturer shall establish the technical documentation. The documentation shall make it possible to assess the EU fertilising product's conformity with the relevant requirements, and shall include an adequate analysis and assessment of the risk(s).

2.2. The technical documentation shall specify the applicable requirements and cover, as far as relevant for the assessment, the design, manufacture and intended use of the EU fertilising product. The technical documentation shall contain, where applicable, at least the following elements: **U.K.**

- (a) a general description of the EU fertilising product, the PFC corresponding to the claimed function of the EU fertilising product and description of the intended use,
- (b) a list of component materials used, the CMCs as referred to in Annex II to which they belong and information about their origin or manufacturing process,
- (c) the EU declarations of conformity for the component EU fertilising products of the fertilising product blend,
- (d) drawings, schemes, descriptions and explanations necessary for the understanding of the manufacturing process of the EU fertilising product,
- (e) a specimen of the label or the leaflet, or both, referred to in Article 6(7) containing the information required in accordance with Annex III,
- (f) a list of the harmonised standards referred to in Article 13, common specifications referred to in Article 14 and/or other relevant technical specifications applied. In the event of partly applied harmonised standards or common specifications, the technical documentation shall specify the parts which have been applied,
- (g) results of calculations made, including the calculations to demonstrate conformity with point 5 of Part II of Annex I, examinations carried out, etc.,
- (h) test reports,
- (i) where the EU fertilising product contains or consists of by-products within the meaning of Directive 2008/98/EC, technical and administrative evidence that the by-products comply with the criteria established by delegated act referred to in Article 42(7) of this Regulation, and with the national measures transposing Article 5(1) of Directive 2008/98/EC and, where applicable, implementing acts referred to in Article 5(2) or national measures adopted under Article 5(3) of that Directive,
- (j) where the EU fertilising product contains total chromium (Cr) above 200 mg/kg, information about the maximum quantity and exact source of total chromium (Cr).

3. Manufacturing **U.K.**

Status: Point in time view as at 05/06/2019.

Changes to legislation: There are currently no known outstanding effects for the Regulation (EU) 2019/1009 of the European Parliament and of the Council. (See end of Document for details)

The manufacturer shall take all measures necessary so that the manufacturing process and its monitoring ensure compliance of the manufactured EU fertilising products with the technical documentation referred to under point 2 and with the requirements of this Regulation that apply to them.

4. CE marking and EU declaration of conformity **U.K.**
 - 4.1. The manufacturer shall affix the CE marking to each individual packaging of the EU fertilising product that satisfies the applicable requirements of this Regulation, or, where it is supplied without packaging, in a document accompanying the EU fertilising product.
 - 4.2. The manufacturer shall draw up a written EU declaration of conformity for an EU fertilising product or type and keep it together with the technical documentation at the disposal of the national authorities for 5 years after the EU fertilising product has been placed on the market. The EU declaration of conformity shall identify the EU fertilising product or type for which it has been drawn up.
 - 4.3. A copy of the EU declaration of conformity shall be made available to the relevant authorities upon request.
5. Authorised representative **U.K.**

The manufacturer's obligations set out under point 4 may be fulfilled by his or her authorised representative, on his or her behalf and under his or her responsibility, provided that they are specified in the mandate.

MODULE A1 – INTERNAL PRODUCTION CONTROL PLUS SUPERVISED PRODUCT TESTING

1. Description of the module **U.K.**

Internal production control plus supervised product testing is the conformity assessment procedure whereby the manufacturer fulfils the obligations laid down under points 2, 3, 4, and 5, and ensures and declares on his or her sole responsibility that the EU fertilising products concerned satisfy the requirements of this Regulation that apply to them.

2. Technical documentation **U.K.**
 - 2.1. The manufacturer shall establish the technical documentation. The documentation shall make it possible to assess the EU fertilising product's conformity with the relevant requirements, and shall include an adequate analysis and assessment of the risk(s).
 - 2.2. The technical documentation shall specify the applicable requirements and cover, as far as relevant for the assessment, the design, manufacture and intended use of the EU fertilising product. The technical documentation shall contain, where applicable, at least the following elements: **U.K.**
 - (a) a general description of the EU fertilising product, the PFC corresponding to the claimed function of the EU fertilising product and description of the intended use,
 - (b) a list of component materials used, the CMCs as referred to in Annex II to which they belong and information about their origin or manufacturing process,
 - (c) the EU declarations of conformity for the component EU fertilising products of the fertilising product blend,

Status: Point in time view as at 05/06/2019.

Changes to legislation: There are currently no known outstanding effects for the Regulation (EU) 2019/1009 of the European Parliament and of the Council. (See end of Document for details)

- (d) drawings, schemes, descriptions and explanations necessary for the understanding of the manufacturing process of the EU fertilising product,
- (e) a specimen of the label or the leaflet, or both, referred to in Article 6(7) containing the information required in accordance with Annex III,
- (f) the names and addresses of the sites, and of the operators of the sites, at which the product and its principal components were manufactured,
- (g) a list of the harmonised standards referred to in Article 13, common specifications referred to in Article 14 and/or other relevant technical specifications applied. In the event of partly applied harmonised standards or common specifications, the technical documentation shall specify the parts which have been applied,
- (h) results of calculations made, including the calculations to demonstrate conformity with point 5 of Part II of Annex I, examinations carried out, etc.,
- (i) test reports, including the reports from product checks for oil retention and detonation resistance, referred to in point 4 and
- (j) where the EU fertilising product contains or consists of by-products within the meaning of Directive 2008/98/EC, technical and administrative evidence that the by-products comply with the criteria established by delegated acts referred to in Article 42(7) of this Regulation, and with the national measures transposing Article 5(1) of Directive 2008/98/EC and, where applicable, implementing acts referred to in Article 5(2) or national measures adopted under Article 5(3) of that Directive.

3. Manufacturing **U.K.**

The manufacturer shall take all measures necessary so that the manufacturing process and its monitoring ensure compliance of the manufactured EU fertilising products with the technical documentation referred to in point 2 and with the requirements of this Regulation that apply to them.

4. Product checks for oil retention and detonation resistance **U.K.**

The thermal cycles and tests referred to in points 4.1 to 4.4 shall be carried out on a representative sample of the EU fertilising product every 3 months on behalf of the manufacturer, in order to verify conformity with:

- (a) the oil retention requirement referred to in point 4 under PFC 1(C)(I)(a)(i-ii)(A) in Annex I, and
- (b) the detonation resistance requirement referred to in point 5 under PFC 1(C)(I)(a)(i-ii)(A) in Annex I.

The thermal cycles and tests shall be carried out under the responsibility of a notified body chosen by the manufacturer.

4.1. Thermal cycles prior to a test for compliance with the oil retention requirement referred to in point 4 under PFC 1(C)(I)(a)(i-ii)(A) in Annex I **U.K.**

4.1.1. Principle and definition **U.K.**

In a closed suitable laboratory flask, heat the sample from ambient temperature to 50 °C and maintain at this temperature for a period of two hours (phase at 50 °C). Thereupon cool the sample until a temperature of 25 °C is achieved and maintain at that temperature for two hours

Status: Point in time view as at 05/06/2019.

Changes to legislation: There are currently no known outstanding effects for the Regulation (EU) 2019/1009 of the European Parliament and of the Council. (See end of Document for details)

(phase at 25 °C). The combination of the successive phases at 50 °C and 25 °C forms one thermal cycle. After being subjected to two thermal cycles, the test sample is held at a temperature of 20 (± 3) °C for the determination of the oil retention value.

4.1.2. Apparatus **U.K.**

Normal laboratory apparatus, in particular:

- (a) water baths or ovens thermostated at 25 ± 1 °C and 50 ± 1 °C respectively,
- (b) suitable laboratory flasks with an individual capacity of 150 ml.

4.1.3. Procedure **U.K.**

- 4.1.3.1. Put each test sample of 70 ± 5 g into a suitable laboratory flask which is then closed.
- 4.1.3.2. After attaining the temperature of 50 °C and maintain that temperature for two hours, change the temperature of the flask to the 25 °C bath or oven and proceed as described in 4.1.1.
- 4.1.3.3. If using a water bath maintain the water of each bath at constant temperature and keep in motion by rapid stirring. Ensure the water level comes above the level of the sample. Protect the stopper from condensation by a foam rubber cap.

4.2. Oil retention test referred to in point 4 under PFC 1(C)(I)(a)(i-ii)(A) in Annex I **U.K.**

4.2.1. Description **U.K.**

The oil retention of an EU fertilising product shall be the quantity of oil retained by the EU fertilising product determined under the operating conditions specified and expressed as a % by mass.

The test shall be carried out on a representative sample of the EU fertilising product. Before being tested, the whole mass of the sample shall be thermally cycled two times in accordance with point 4.1.

The method is applicable to both prilled and granular fertilisers which do not contain oil soluble materials.

4.2.2. Principle **U.K.**

Total immersion of the test sample in gas oil for a specified period, followed by the draining away of surplus oil under specified conditions. Measurement of the increase in mass of the test portion.

4.2.3. Reagents **U.K.**

Gas oil with the following characteristics:

- (a) viscosity max.: 5 mPas at 40 °C;
- (b) density: 0,8 g/ml to 0,85 g/ml at 20 °C;
- (c) sulphur content: ≤ 1,0 % (m/m);
- (d) ash: ≤ 0,1 % (m/m).

4.2.4. Apparatus **U.K.**

Ordinary laboratory apparatus, and:

Status: Point in time view as at 05/06/2019.

Changes to legislation: There are currently no known outstanding effects for the Regulation (EU) 2019/1009 of the European Parliament and of the Council. (See end of Document for details)

- (a) balance, capable of weighing to the nearest 0,01 g;
- (b) beakers, of capacity 500 ml;
- (c) funnel, of plastic materials, preferably with a cylindrical wall at the upper end, diameter approximately 200 mm;
- (d) test sieve, aperture 0,5 mm, fitting into the funnel;

Note: The size of the funnel and sieve is such as to ensure that only a few granules lie one above another and the oil is able to drain easily.

- (e) filter paper, rapid filtering grade, creped, soft, mass 150 g/m²;
- (f) absorbent tissue (laboratory grade).

4.2.5. Procedure **U.K.**

4.2.5.1. Two individual determinations are carried out in quick succession on separate portions of the same test sample.

4.2.5.2. Remove particles smaller than 0,5 mm using the test sieve. Weigh to the nearest 0,01 g approximately 50 g of the sample into the beaker. Add sufficient gas oil to cover the prills or granules completely and stir carefully to ensure that the surfaces of all the prills or granules are fully wetted. Cover the beaker with a watch glass and leave to stand for one hour at 25 (± 2) °C.

4.2.5.3. Filter the entire contents of the beaker through the funnel containing the test sieve. Allow the portion retained by the sieve to remain there for one hour so that most of the excess oil can drain away.

4.2.5.4. Lay two sheets of filter paper (about 500 mm x 500 mm) on top of each other on a smooth surface; fold the four edges of both filter papers upwards to a width of about 40 mm to prevent the prills or granules from rolling away. Place two layers of absorbent tissue in the centre of the filter papers. Pour the entire contents of the sieve over the absorbent tissues and spread the prills or granules evenly with a soft, flat brush. After two minutes lift one side of the tissues to transfer the prills or granules to the filter papers beneath and spread them evenly over these with the brush. Lay another sheet of filter paper, similarly with its edges turned upward, on the sample and roll the prills or granules between the filter papers with circular movements while exerting a little pressure. Pause after every eight circular movements to lift the opposite corners of the filter papers and return to the centre the prills or granules that have rolled to the periphery. Keep to the following procedure: make four complete circular movements, first clockwise and then anticlockwise. Then roll the prills or granules back to the centre as described above. This procedure is to be carried out three times (24 circular movements, corners lifted twice). Carefully insert a new sheet of filter paper between the bottom sheet and the one above it and allow the prills or granules to roll onto the new sheet by lifting the edges of the upper sheet. Cover the prills or granules with a new sheet of filter paper and repeat the same procedure as described above. Immediately after rolling, pour the prills or granules into a tared dish and reweigh to the nearest 0,01 g to determine the mass of the quantity of gas oil retained.

4.2.5.5. Repeating the rolling procedure and reweighing **U.K.**

If the quantity of gas oil retained in the portion is found to be greater than 2,00 g, place the portion on a fresh set of filter papers and repeat the rolling procedure, lifting the corners in

Status: Point in time view as at 05/06/2019.

Changes to legislation: There are currently no known outstanding effects for the Regulation (EU) 2019/1009 of the European Parliament and of the Council. (See end of Document for details)

accordance with point 4.2.5.4 (two times eight circular movements, lifting once). Then reweigh the portion.

4.2.5.6. Two oil retention tests per sample are to be carried out.

4.2.6. Test report **U.K.**

4.2.6.1. Expression of the results **U.K.**

4.2.6.1.1. Method of calculation and formula **U.K.**

The oil retention, from each determination (point 4.2.5.1) expressed as a % by mass of the sieved test portion, is given by the equation:

$$\text{Oil retention} = \frac{m_2 - m_1}{m_1} \times 100$$

where:

m_1 is the mass, in grams, of the sieved test portion (point 4.2.5.2),

m_2 is the mass, in grams, of the test portion according to points 4.2.5.4 and 4.2.5.5 respectively as the result of the last weighing.

4.2.6.1.2. Take as the result the arithmetic mean of the two individual determinations.

4.2.6.2. The test report shall form part of the technical documentation.

4.3. Thermal cycles prior to the detonation resistance test referred to in point 5 under PFC 1(C)(I)(a)(i-ii)(A) in Annex I **U.K.**

4.3.1. Principle and definition **U.K.**

In a tight box heat the sample from ambient temperature to 50 °C and maintain at this temperature for a period of one hour (phase at 50 °C). Thereupon cool the sample until a temperature of 25 °C is achieved and maintain at that temperature for one hour (phase at 25 °C). The combination of the successive phases at 50 °C and 25 °C forms one thermal cycle. After being subjected to the required number of thermal cycles, the test sample is held at a temperature of 20 ± 3 °C pending the execution of the detonation resistance test.

4.3.2. Apparatus **U.K.**

Method 1

- (a) A water bath, thermostated in a temperature range of 20 to 51 °C with a minimum heating and cooling rate of 10 °C/h, or two water baths, one thermostated at a temperature of 20 °C, the other at 51 °C. The water in the bath(s) is continuously stirred; the volume of the bath shall be large enough to guarantee ample circulation of the water.
- (b) A stainless steel box, watertight all around and provided with a temperature recording device in the centre. The outside width of the box is 45 ± 2 mm and the wall thickness is 1,5 mm (see Figure 1 as an example). The height and length of the box can be chosen to suit the dimensions of the water bath, e.g. length 600 mm, height 400 mm.

Method 2

- (a) Suitable oven, thermostated in a temperature range of 20 °C to 51 °C with a minimum heating and cooling rate of 10 °C/h.
- (b) Suitable airtight plastics boxes or bags provided with a suitable temperature recording device in the centre of the sample or a stainless steel box as described in point (b) of

Status: Point in time view as at 05/06/2019.

Changes to legislation: There are currently no known outstanding effects for the Regulation (EU) 2019/1009 of the European Parliament and of the Council. (See end of Document for details)

method 1 of point 4.3.2. Once filled, the outside thickness of the box or bag shall be maximum 45 mm.

4.3.3. Procedure **U.K.**

Place a quantity of fertilisers sufficient for the detonation resistance test into the boxes or bags and close them. Place the stainless steel boxes in the water bath (method 1) or the boxes or bags in the oven (method 2). Heat the water or oven to 51 °C and measure the temperature in the centre of the fertiliser. One hour after the temperature at the centre has reached 50 °C start cooling. One hour after the temperature at the centre has reached 25 °C start heating for the second cycle. In the case of two water baths or ovens, transfer the boxes or bags to the other bath or oven after each heating/cooling period.

Figure 1

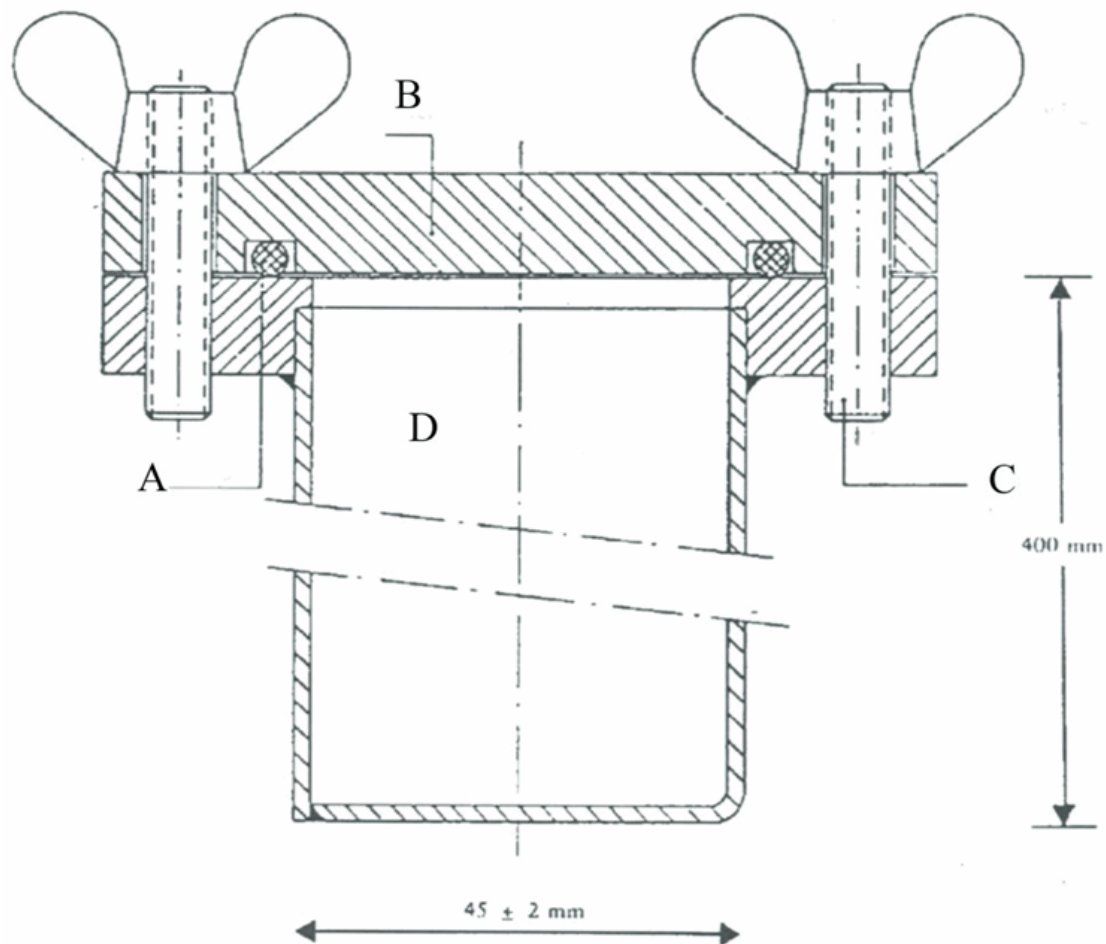

- | | |
|---|----------|
| A | : O-ring |
| B | : Cover |
| C | : Bolt |
| D | : Box |

4.4. Detonation resistance test referred to in point 5 under PFC 1(C)(I)(a)(i-ii)(A) in Annex I **U.K.**

4.4.1. Description **U.K.**

Status: Point in time view as at 05/06/2019.

Changes to legislation: There are currently no known outstanding effects for the Regulation (EU) 2019/1009 of the European Parliament and of the Council. (See end of Document for details)

4.4.1.1. The test shall be carried out on a representative sample of the EU fertilising product. Before being tested for resistance to detonation, the whole mass of the sample is to be thermally cycled five times in accordance with point 4.3.

4.4.1.2. The EU fertilising product shall be subjected to the detonation resistance test in a horizontal steel tube under the following conditions (the details of the materials are in point 4.4.3): **U.K.**

- (a) seamless steel tube:
 - (i) Tube length: 1 000 mm at least,
 - (ii) Nominal external diameter: 114 mm at least,
 - (iii) Nominal wall thickness: 5 mm at least,
- (b) booster: the type and mass of the booster chosen shall be such as to maximise the detonation pressure applied to the sample in order to determine its susceptibility to the transmission of detonation,
- (c) temperature of the sample: 15 °C to 25 °C,
- (d) witness lead cylinders for detecting detonation: 50 mm diameter and 100 mm height,
- (e) placed at 150 mm intervals and supporting the tube horizontally.

NOTE: The test is to be carried out twice. The test is deemed conclusive if in both tests one or more of the supporting lead cylinders is crushed by less than 5 %.

4.4.2. Principle **U.K.**

The test sample is confined in a steel tube and subjected to detonation shock from an explosive booster charge. Propagation of the detonation is determined from the degree of crushing of lead cylinders on which the tube rests horizontally during the test.

4.4.3. Materials **U.K.**

- (a) Plastic explosive containing 83 % to 86 % penthrite
 - density: 1 500 kg/m³ to 1 600 kg/m³
 - detonation velocity: 7 300 m/s to 7 700 m/s
 - mass: (500 ± 1) g;or any other plastic explosive with similar detonation characteristics.
- (b) Seven lengths of flexible detonating cord with non-metallic sleeve
 - filling mass: 11 g/m to 13 g/m
 - length of each cord: (400 ± 2) mm.
- (c) Compressed pellet of secondary explosive, recessed to receive detonator
 - explosive: hexogen/wax 95/5 or similar secondary explosive, with or without added graphite
 - density: 1 500 kg/m³ to 1 600 kg/m³
 - diameter: 19 mm to 21 mm
 - height: 19 mm to 23 mm
 - mass of the compressed pellet: maximum 10 g

Status: Point in time view as at 05/06/2019.

Changes to legislation: There are currently no known outstanding effects for the Regulation (EU) 2019/1009 of the European Parliament and of the Council. (See end of Document for details)

- central recess to receive detonator: maximal diameter 7,0 to 7,3 mm, depth about 12 mm. In case of detonators with large diameters, the diameter of the recess shall be slightly larger (e.g. 0,5 mm) than the diameter of the detonator.
- (d) Seamless steel tube as specified in ISO 65 – 1981 – Heavy Series, with nominal dimensions DN 100 (4")
 - outside diameter: 113,1 mm to 115,0 mm
 - wall thickness: 5,0 mm to 6,5 mm
 - length: $1\ 005 \pm 2$ mm.
- (e) Bottom plate
 - material: steel of good weldable quality
 - dimensions: 160 mm × 160 mm
 - thickness: 5 mm to 6 mm.
- (f) Six lead cylinders
 - diameter: 50 ± 1 mm
 - height: 100 mm to 101 mm
 - materials: soft lead, at least 99,5 % purity.
- (g) Steel block
 - length: at least 1 000 mm
 - width: at least 150 mm
 - height: at least 150 mm (alternatively a stack of several beams can be used to achieve this height)
 - Mass: at least 300 kg if there is no firm base for the steel block.
- (h) Plastic or cardboard cylinder for booster charge
 - wall thickness: 1,5 mm to 2,5 mm
 - diameter: 92 mm to 96 mm
 - height: 64 mm to 67 mm.
- (i) Detonator (electric or non-electric) with initiation force 8 to 10
- (j) Wooden or plastic disc
 - diameter: 92 mm to 96 mm. Diameter to be matched to the internal diameter of the plastic or cardboard cylinder (point (h))
 - thickness: 20 mm.
- (k) Wooden or plastic rod of same dimensions as detonator (point (i))
- (l) Small split pins (maximum length 20 mm)
- (m) Split pins (length about 20 mm)

4.4.4. Procedure **U.K.**

4.4.4.1. Preparation of booster charge for insertion into steel tube **U.K.**

Depending on the availability of equipment, the explosive can be initiated in the booster charge either

- by seven-point simultaneous initiation as referred to in point 4.4.4.1.1, or
- by central initiation by a compressed pellet as referred to in point 4.4.4.1.2.

Status: Point in time view as at 05/06/2019.

Changes to legislation: There are currently no known outstanding effects for the Regulation (EU) 2019/1009 of the European Parliament and of the Council. (See end of Document for details)

4.4.4.1.1. Seven-point simultaneous initiation **U.K.**

The booster charge prepared for use is shown in Figure 2.

4.4.4.1.1.1. Drill holes in the wooden or plastic disc (point (j) under point 4.4.3) parallel to the axis of the disc through the centre and through six points symmetrically distributed around a concentric circle 55 mm in diameter. The diameter of the holes shall be 6 mm to 7 mm (see Section A-B in Figure 2), depending on the diameter of the detonating cord used (point (b) under point 4.4.3).

4.4.4.1.1.2. Cut seven lengths of flexible detonating cord (point (b) under point 4.4.3) each 400 mm long, avoiding any loss of explosive at each end by making a clean cut and immediately sealing the end with adhesive. Push each of the seven lengths through each of the seven holes in the wooden or plastic disc (point (j) under point 4.4.3) until their ends project a few centimetres on the other side of the disc. Then insert a small split pin (point (l) under point 4.4.3) transversally into the textile sleeve of each length of cord 5 mm to 6 mm from the end and apply adhesive around the outside of the lengths of cord in a band 2 cm wide adjacent to the pin. Finally, pull the long piece of each cord to bring the pin into contact with the wooden or plastic disc.

4.4.4.1.1.3. Shape the plastic explosive (point (a) under point 4.4.3) to form a cylinder 92 mm to 96 mm in diameter, depending on the diameter of the cylinder (point (h) under point 4.4.3). Stand this cylinder upright on a level surface and insert the shaped explosive. Then insert the wooden or plastic disc⁽⁴⁷⁾ carrying the seven lengths of detonating cord into the top of the cylinder and press it down onto the explosive. Adjust the height of the cylinder (64 mm to 67 mm) so that its top edge does not extend beyond the level of the wood or plastic. Finally, fix the cylinder to the wooden or plastic disc for instance with staples or small nails, around its entire circumference.

4.4.4.1.1.4. Group the free ends of the seven lengths of detonating cord around the circumference of the wooden or plastic rod (point (k) under point 4.4.3) so that their ends are all level in a plane perpendicular to the rod. Secure them in a bundle around the rod by means of adhesive tape⁽⁴⁸⁾.

4.4.4.1.2. Central initiation by a compressed pellet **U.K.**

The booster charge prepared for use is shown in Figure 3.

4.4.4.1.2.1. Preparing a compressed pellet **U.K.**

Taking the necessary safety precautions, place maximum 10 g of a secondary explosive (point (c) under point 4.4.3) in a mould with an inside diameter of 19 mm to 21 mm and compress to the correct shape and density (the ratio of diameter: height should be roughly 1:1). In the centre of the bottom of the mould there is a peg, 12 mm in height and 7,0 mm to 7,3 mm in diameter (depending on the diameter of the detonator used), which forms a cylindrical recess in the compressed cartridge for subsequent insertion of the detonator.

4.4.4.1.2.2. Preparing the booster charge **U.K.**

Place the explosive (point (a) under point 4.4.3) into the cylinder (point (h) under point 4.4.3) standing upright on a level surface, then press it down with a wooden or plastic die to give the explosive a cylindrical shape with a central recess. Insert the compressed pellet into this recess. Cover the cylindrically shaped explosive containing the compressed pellet with a wooden or plastic disc (point (j) under point 4.4.3) having a central hole 7,0 mm to 7,3 mm in diameter for insertion of a detonator. Fix the wooden or plastic disc and the cylinder together with a cross

Status: Point in time view as at 05/06/2019.

Changes to legislation: There are currently no known outstanding effects for the Regulation (EU) 2019/1009 of the European Parliament and of the Council. (See end of Document for details)

of adhesive tape. Ensure that the hole drilled in the disc and the recess in the compressed pellet are coaxial by inserting the wooden or plastic rod (point (k) under point 4.4.3).

4.4.4.2. Preparing steel tubes for the detonation tests **U.K.**

At one end of the steel tube (point (d) under point 4.4.3), drill two diametrically opposed holes 4 mm in diameter perpendicularly through the side wall at a distance of 4 mm from the edge. Butt weld the bottom plate (point (e) under point 4.4.3) to the opposite end of the tube, completely filling the right angle between the bottom plate and the wall of the tube with weld metal around the entire circumference of the tube.

4.4.4.3. Filling and charging the steel tube **U.K.**

See Figures 2 and 3.

4.4.4.3.1. The test sample, the steel tube and the booster charge shall be conditioned to temperatures of (20 ± 5) °C. About 20 kg of the test sample should be available for two detonation resistance tests.

4.4.4.3.2. Place the tube upright with its square bottom plate resting on a firm, flat surface, preferably concrete. Fill the tube to about one-third of its height with the test sample and drop it 10 cm vertically onto the flat surface five times to compact the prills or granules as densely as possible in the tube. To accelerate compaction, vibrate the tube by striking the side wall with a 750 g to 1 000 g hammer between drops for a total of 10 times.

4.4.4.3.2. Repeat this charging method with another portion of the test sample. Finally, a further addition shall be made such that, after compaction by raising and dropping the tube 10 times and a total of 20 intermittent hammer blows, the charge fills the tube to a distance of 70 mm from its orifice.

4.4.4.3.2. The filling height of the sample shall be adjusted in the steel tube so that the booster charge (referred to in point 4.4.4.1.1 or 4.4.4.1.2) to be inserted later will be in close contact with the sample over its entire surface.

4.4.4.3.3. Insert the booster charge into the tube so that it is in contact with the sample; the top surface of the wooden or plastic disc shall be 6 mm below the end of the tube. Ensure essential close contact between explosive and test sample by taking out the booster charge and adding or removing small quantities of sample. As shown in Figures 2 and 3, split pins should be inserted through the holes near the open end of the tube and their legs opened flat against the tube.

4.4.4.4. Positioning of the steel tube and lead cylinders (see Figure 4) **U.K.**

4.4.4.4.1. Number the bases of the lead cylinders (point (f) under point 4.4.3) 1, 2, 3, 4, 5 and 6. Make six marks 150 mm apart along a line on a steel block (point 4.4.3(g)) lying on a horizontal base, with each mark at least 75 mm from any edge of the block. Place a lead cylinder upright on each of these marks, with the base of each cylinder centred on its mark (see Figure 4).

4.4.4.4.2. Lay the steel tube prepared according to point 4.4.4.3 horizontally on the lead cylinders so that the axis of the tube is parallel to the centre line of the lead cylinders and the welded end of the tube extends 50 mm beyond lead cylinder No 6. To prevent the tube from rolling, insert small wooden or plastic wedges between the tops of the lead cylinders and the tube wall (one on each side) or place a cross of wood between the tube and the steel block or stack of beams. (see Figure 4). **U.K.**

Status: Point in time view as at 05/06/2019.

Changes to legislation: There are currently no known outstanding effects for the Regulation (EU) 2019/1009 of the European Parliament and of the Council. (See end of Document for details)

Note: Make sure that the tube is in contact with all six lead cylinders; a slight curvature of the tube surface can be compensated for by rotating the tube about its longitudinal axis; if any of the lead cylinders is too tall, tap the cylinder in question carefully with a hammer until it is the required height.

4.4.4.5. Preparation for detonation **U.K.**

4.4.4.5.1. Set up the apparatus as described in point 4.4.4.4 in a bunker or suitably prepared underground site or suitable location. Ensure that the temperature of the steel tube is kept at (20 ± 5) °C before detonation. **U.K.**

Note: Detonation can cause steel fragments to be projected with high kinetic energy, therefore, firing shall be carried out at a suitable distance from dwellings or thoroughfares.

4.4.4.5.2. If the booster charge with seven-point initiation is used, ensure that the detonation cords are stretched out as described in the footnote to point 4.4.4.1.1.4 and arranged as horizontally as possible.

4.4.4.5.3. Finally, remove the wooden or plastic rod and replace with the detonator. Do not carry out firing until the danger zone has been evacuated and the test personnel have taken cover.

4.4.4.5.4. Detonate the explosive.

4.4.4.6.1. Allow sufficient time for the fumes (gaseous and sometimes toxic decomposition products such as nitrous gases) to disperse, then collect the lead cylinders and measure their heights with a Vernier caliper.

4.4.4.6.2. Record for each of the marked lead cylinders, the degree of crushing expressed as a percentage of the original height of 100 mm. If the cylinders are crushed obliquely, record the highest and the lowest values and calculate the average.

4.4.4.7. Detonation velocity measurement can also be performed.

4.4.4.8. Two detonation tests per sample are to be carried out.

4.4.5. Test report **U.K.**

Values for the following parameters are to be given in the test report for each of the detonation resistance tests:

- the values actually measured for the outside diameter of the steel tube and for the wall thickness,
- the Brinell hardness of the steel tube,
- the temperature of the tube and the sample shortly before firing,
- the packing density (kg/m^3) of the sample in the steel tube,
- the height of each lead cylinder after firing, specifying the corresponding cylinder number,
- method of initiation employed for the booster charge.

4.4.6. Evaluation of test results **U.K.**

If, in each firing, the crushing of at least one lead cylinder is less than 5 %, the test shall be considered conclusive and it shall be considered that the sample presented is resistant to detonation.

4.4.7. The test report shall form part of the technical documentation. **U.K.**

Figure 2

Status: Point in time view as at 05/06/2019.

Changes to legislation: There are currently no known outstanding effects for the Regulation (EU) 2019/1009 of the European Parliament and of the Council. (See end of Document for details)

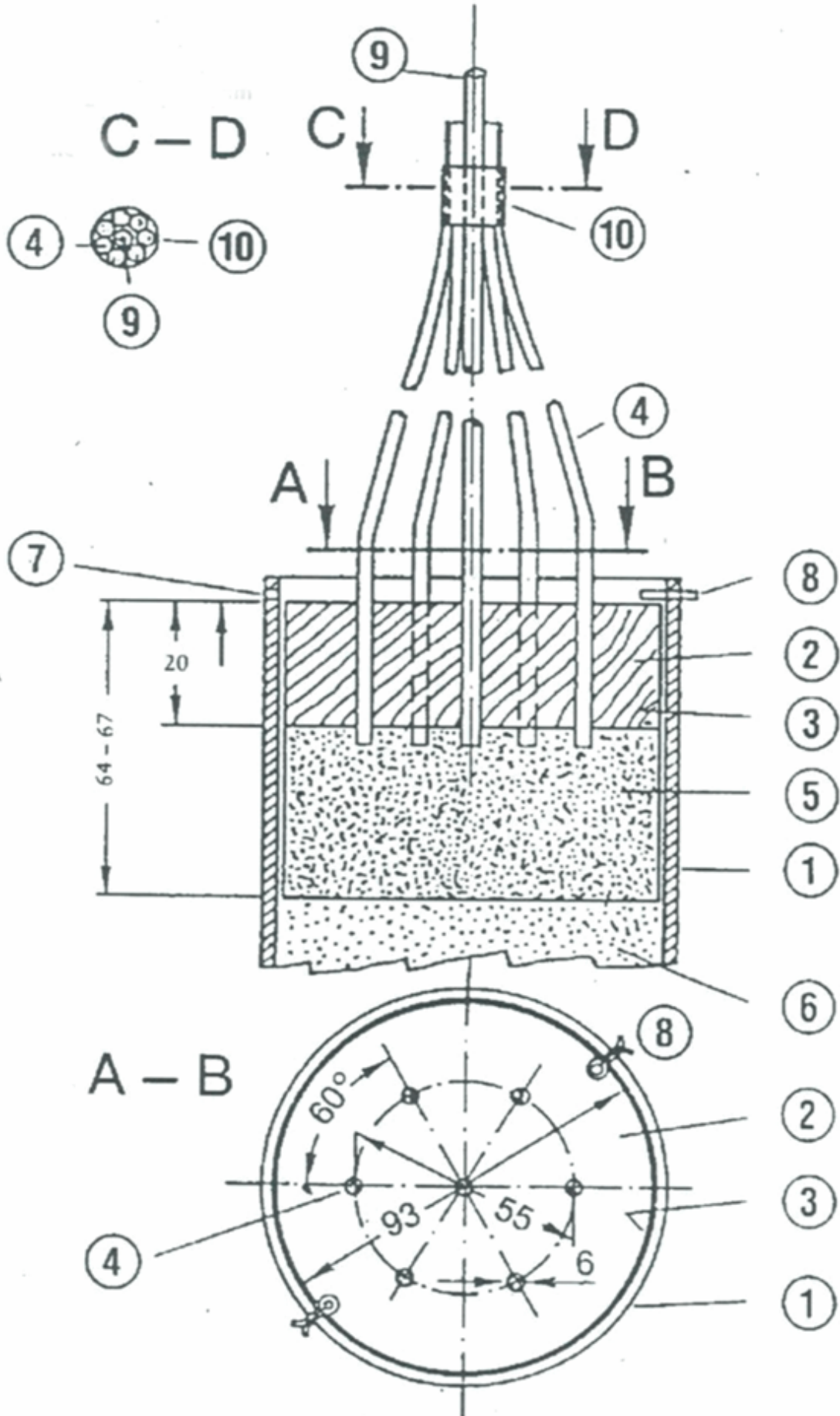

Status: Point in time view as at 05/06/2019.

Changes to legislation: There are currently no known outstanding effects for the Regulation (EU) 2019/1009 of the European Parliament and of the Council. (See end of Document for details)

Booster charge with seven-point initiation

- 1 : Steel tube
- 2 : Wooden or plastic disc with seven holes
- 3 : Plastic or cardboard cylinder
- 4 : Detonating cords
- 5 : Plastic explosive
- 6 : Test sample
- 7 : 4 mm hole drilled to receive split pin
- 8 : Split pin
- 9 : Wooden or plastic rod surrounded by 4
- 10 : Adhesive tape for securing 4 around 9

Figure 3

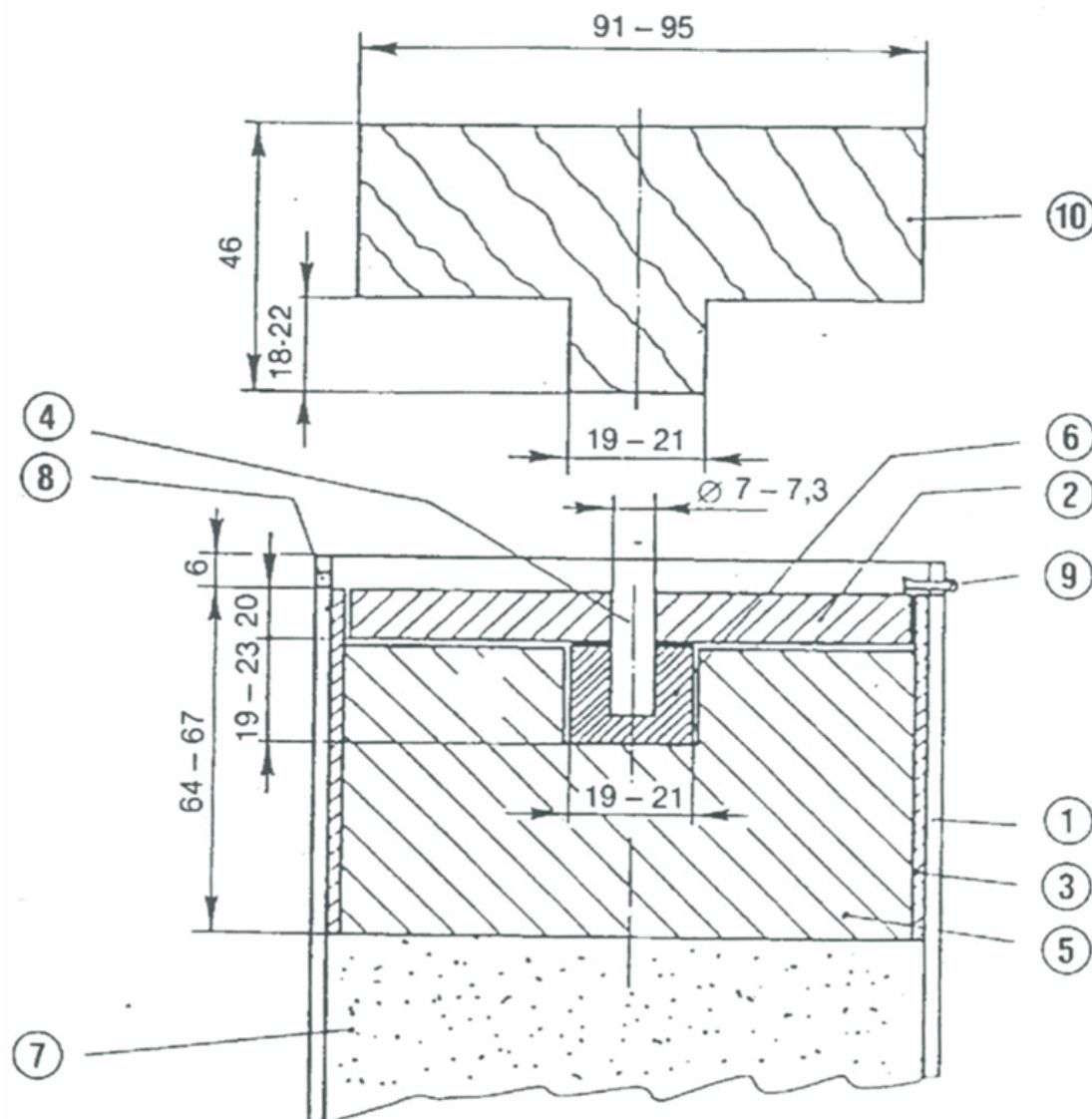

- 1 : Steel tube
- 2 : Wooden or plastic disc
- 3 : Plastic or cardboard cylinder

Status: Point in time view as at 05/06/2019.

Changes to legislation: There are currently no known outstanding effects for the Regulation (EU) 2019/1009 of the European Parliament and of the Council. (See end of Document for details)

- 4 : Wooden or plastic rod
 5 : Plastic explosive
 6 : Compressed pellet
 7 : Test sample
 8 : 4 mm hole drilled to receive split pin
 9 : Split pin
 10 : Wooden or plastic die for 5
- Figure 4

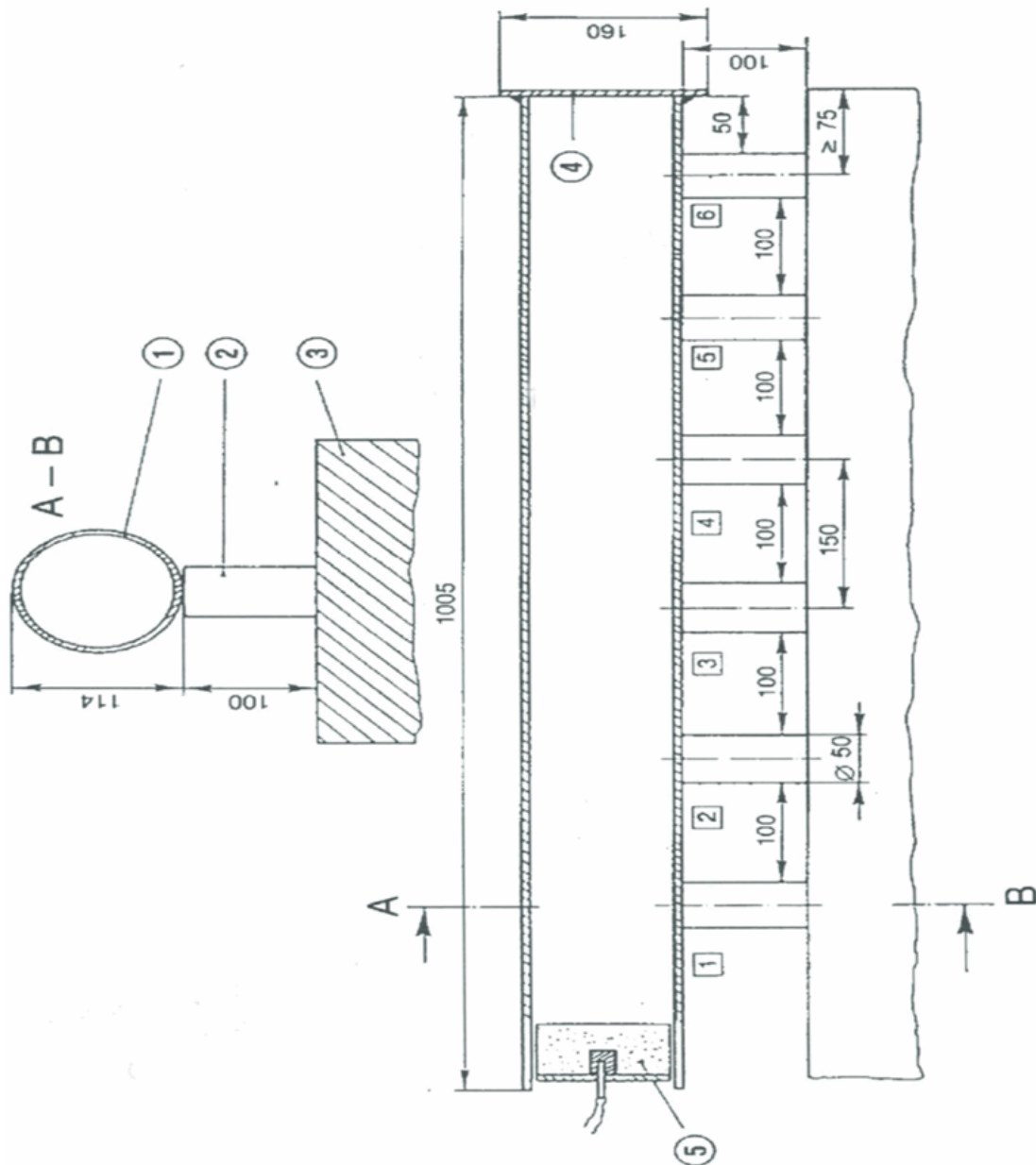

Numbers in circles:

- 1 : Steel tube
 2 : Lead cylinders

Status: Point in time view as at 05/06/2019.

Changes to legislation: There are currently no known outstanding effects for the Regulation (EU) 2019/1009 of the European Parliament and of the Council. (See end of Document for details)

- 3 : Steel block or stack of beams
- 4 : Bottom plate
- 5 : Booster charge

Numbers in squares:

Lead cylinders 1 to 6

- 5. CE marking and EU declaration of conformity **U.K.**
 - 5.1. The manufacturer shall affix the CE marking and, under the responsibility of the notified body referred to in point 4, the latter's identification number to each individual packaging of the EU fertilising product that satisfies the applicable requirements of this Regulation or, where it is supplied without packaging, in a document accompanying the EU fertilising product.
 - 5.2. The manufacturer shall draw up a written EU declaration of conformity for an EU fertilising product type and keep it together with the technical documentation at the disposal of the national authorities for 5 years after the EU fertilising product has been placed on the market. The EU declaration of conformity shall identify the EU fertilising product type for which it has been drawn up.
 - 5.3. A copy of the EU declaration of conformity shall be made available to the relevant authorities upon request.
- 6. Notified bodies' information and operational obligations **U.K.**
 - 6.1. Each notified body shall, without undue delay, inform its notifying authority and other bodies notified under this Regulation carrying out similar conformity assessment activities covering the same EU fertilising products of the following: **U.K.**
 - (a) any case where the manufacturer has not complied with the 3-month period for performing the tests required under point 4;
 - (b) any test results which demonstrate non-conformity with the detonation resistance requirement referred to in point 5 under PFC 1(C)(I)(a)(i-ii)(A) in Annex I.
 - 6.2. In the case referred to in point 6.1(b) the notified body shall request the manufacturer to take the necessary measures in accordance with Article 6(8).
- 7. Authorised representative **U.K.**

The manufacturer's obligations set out in points 4.4.7 and 5 may be fulfilled by his or her authorised representative, on his or her behalf and under his or her responsibility, provided that they are specified in the mandate.

MODULE B – EU-TYPE EXAMINATION

- 1. Description of the module **U.K.**
 - 1.1. EU-type examination is the part of a conformity assessment procedure in which a notified body examines the technical design of an EU fertilising product and verifies and attests that the technical design of the EU fertilising product meets the requirements of this Regulation.
 - 1.2. Assessment of the adequacy of the technical design of the EU fertilising product is carried out through examination of the technical documentation and supporting evidence, plus examination of samples, representative of the production envisaged.

Status: Point in time view as at 05/06/2019.

Changes to legislation: There are currently no known outstanding effects for the Regulation (EU) 2019/1009 of the European Parliament and of the Council. (See end of Document for details)

2. Technical documentation **U.K.**
 - 2.1. The manufacturer shall establish the technical documentation. The documentation shall make it possible to assess the EU fertilising product's conformity with the relevant requirements and shall include an adequate analysis and assessment of the risk(s).
 - 2.2. The technical documentation shall specify the applicable requirements and cover, as far as relevant for the assessment, the design, manufacture and intended use of the EU fertilising product. The technical documentation shall contain, where applicable, at least the following elements: **U.K.**
 - (a) a general description of the EU fertilising product, the PFC corresponding to the claimed function of the EU fertilising product and description of the intended use,
 - (b) a list of component materials used, the CMCs as referred to in Annex II to which they belong and information about their origin or manufacturing process,
 - (c) the EU declarations of conformity for the component EU fertilising products of the fertilising product blend,
 - (d) drawings, schemes, descriptions and explanations necessary for the understanding of the manufacturing process of the EU fertilising product,
 - (e) a specimen of the label or the leaflet, or both, referred to in Article 6(7) containing the information required in accordance with Annex III,
 - (f) a list of the harmonised standards referred to in Article 13, common specifications referred to in Article 14 and/or other relevant technical specifications applied. In the event of partly applied harmonised standards or common specifications, the technical documentation shall specify the parts which have been applied,
 - (g) results of calculations made, including the calculations to demonstrate conformity with point 5 of Part II of Annex I, examinations carried out, etc.,
 - (h) test reports,
 - (i) where the EU fertilising product contains or consists of derived products within the meaning of Regulation (EC) No 1069/2009, the commercial documents or health certificates required pursuant to that Regulation, and evidence that the derived products have reached the end point in the manufacturing chain within the meaning of that Regulation,
 - (j) where the EU fertilising product contains or consists of by-products within the meaning of Directive 2008/98/EC, technical and administrative evidence that the by-products comply with the criteria established by delegated act referred to in Article 42(7) of this Regulation, and with the national measures transposing Article 5(1) of Directive 2008/98/EC and, where applicable, implementing acts referred to in Article 5(2) or national measures adopted under Article 5(3) of that Directive, and
 - (k) where the EU fertilising product contains total chromium (Cr) above 200 mg/kg, information about the maximum quantity and exact source of total chromium (Cr).
3. Application for EU-type examination **U.K.**

Status: Point in time view as at 05/06/2019.

Changes to legislation: There are currently no known outstanding effects for the Regulation (EU) 2019/1009 of the European Parliament and of the Council. (See end of Document for details)

- 3.1. The manufacturer shall lodge an application for EU-type examination with a single notified body of his or her choice.
- 3.2. The application shall include: **U.K.**
 - (a) the name and address of the manufacturer and, if the application is lodged by the authorised representative, his or her name and address as well,
 - (b) a written declaration that the same application has not been lodged with any other notified body,
 - (c) the technical documentation referred to in point 2,
 - (d) the samples representative of the production envisaged. The notified body may request further samples if needed for carrying out the test programme,
 - (e) the supporting evidence for the adequacy of the technical design solution. This supporting evidence shall mention any documents that have been used, in particular where the relevant harmonised standards or common specifications have not been applied in full. The supporting evidence shall include, where necessary, the results of tests carried out in accordance with other relevant technical specifications by the appropriate laboratory of the manufacturer, or by another testing laboratory on his or her behalf and under his or her responsibility.
4. Assessment of the adequacy of the technical design **U.K.**

The notified body shall:

- (a) examine the technical documentation and supporting evidence to assess the adequacy of the technical design of the EU fertilising product;
 - (b) verify that the sample(s) have been manufactured in conformity with the technical documentation, and identify the elements which have been designed in accordance with the applicable provisions of the relevant harmonised standards or common specifications, as well as the elements which have been designed in accordance with other relevant technical specifications;
 - (c) carry out appropriate examinations and tests on the sample(s), or have them carried out, to check whether, where the manufacturer has chosen to apply the solutions in the relevant harmonised standards or common specifications, these have been applied correctly;
 - (d) carry out appropriate examinations and tests on the sample(s), or have them carried out, to check whether, where the solutions in the relevant harmonised standards or common specifications have not been applied, or where relevant harmonised standards or common specifications do not exist, the solutions adopted by the manufacturer meet the corresponding requirements of this Regulation;
 - (e) agree with the manufacturer on a location where the examinations and tests will be carried out.
5. Evaluation report **U.K.**

The notified body shall draw up an evaluation report that records the activities undertaken in accordance with point 4 and their outcomes. Without prejudice to its obligations vis-à-vis the notifying authority, the notified body shall release the content of that report, in full or in part, only with the agreement of the manufacturer.

Status: Point in time view as at 05/06/2019.

Changes to legislation: There are currently no known outstanding effects for the Regulation (EU) 2019/1009 of the European Parliament and of the Council. (See end of Document for details)

6. EU-type examination certificate **U.K.**
 - 6.1. Where the type meets the requirements of this Regulation that apply to the EU fertilising product concerned, the notified body shall issue an EU-type examination certificate to the manufacturer. The certificate shall contain the name and address of the manufacturer, the conclusions of the examination, the conditions (if any) for its validity and the necessary data for identification of the approved type. The EU-type examination certificate may have one or more annexes attached.
 - 6.2. The EU-type examination certificate and its annexes shall contain all relevant information to allow the conformity of manufactured EU fertilising products with the examined type to be evaluated.
 - 6.3. Where the type does not satisfy the requirements of this Regulation, the notified body shall refuse to issue an EU-type examination certificate and shall inform the applicant accordingly, giving detailed reasons for its refusal.
7. Changes which may affect the conformity of the EU fertilising product **U.K.**
 - 7.1. The notified body shall keep itself apprised of any changes in the generally acknowledged state of the art which indicate that the approved type may no longer comply with the requirements of this Regulation and shall determine whether such changes require further investigation. If so, the notified body shall inform the manufacturer accordingly.
 - 7.2. The manufacturer shall inform the notified body that holds the technical documentation relating to the EU-type examination certificate of all modifications to the approved type that may affect the conformity of the EU fertilising product with the requirements of this Regulation or the conditions for validity of the EU-type examination certificate. Such modifications shall require additional approval in the form of an addition to the original EU-type examination certificate.
8. Notified bodies' information obligation **U.K.**
 - 8.1. Each notified body shall inform its notifying authority concerning the EU-type examination certificates and/or any additions thereto which it has issued or withdrawn, and shall, periodically or upon request, make available to its notifying authority the list of EU-type examination certificates and/or any additions thereto refused, suspended or otherwise restricted.
 - 8.2. Each notified body shall inform the other notified bodies concerning the EU-type examination certificates and/or any additions thereto which it has refused, withdrawn, suspended or otherwise restricted, and, upon request, concerning the EU-type examination certificates and/or additions thereto which it has issued.
 - 8.3. The Commission, the Member States and the other notified bodies may, on request, obtain a copy of the EU-type examination certificates and/or additions thereto. On request, the Commission and the Member States may obtain a copy of the technical documentation and the results of the examinations carried out by the notified body.
9. Availability of the EU-type examination certificate **U.K.**
 - 9.1. The notified body shall keep a copy of the EU-type examination certificate, its annexes and additions, as well as the technical file including the documentation submitted by the manufacturer, until the expiry of the validity of the EU-type examination certificate.

Status: Point in time view as at 05/06/2019.

Changes to legislation: There are currently no known outstanding effects for the Regulation (EU) 2019/1009 of the European Parliament and of the Council. (See end of Document for details)

9.2. The manufacturer shall keep a copy of the EU-type examination certificate, its annexes and additions together with the technical documentation at the disposal of the national authorities for 5 years after the EU fertilising product has been placed on the market.

10. Authorised representative **U.K.**

The manufacturer's authorised representative may lodge the application referred to in point 3 and fulfil the obligations set out in points 7 and 9.2, provided that they are specified in the mandate.

MODULE C – CONFORMITY TO TYPE BASED ON INTERNAL PRODUCTION CONTROL

1. Description of the module **U.K.**

Conformity to type based on internal production control is the part of a conformity assessment procedure whereby the manufacturer fulfils the obligations laid down in points 2 and 3, and ensures and declares on his or her sole responsibility that the EU fertilising products concerned are in conformity with the type described in the EU-type examination certificate and satisfy the requirements of this Regulation that apply to them.

2. Manufacturing **U.K.**

The manufacturer shall take all measures necessary so that the manufacturing process and its monitoring ensure conformity of the manufactured EU fertilising products with the approved type described in the EU-type examination certificate and with the requirements of this Regulation that apply to them.

3. CE marking and EU declaration of conformity **U.K.**

3.1 The manufacturer shall affix the CE marking to each individual packaging of the EU fertilising product that is in conformity with the type described in the EU-type examination certificate and satisfies the applicable requirements of this Regulation or, where it is supplied without packaging, in a document accompanying the EU fertilising product.

3.2 The manufacturer shall draw up a written EU declaration of conformity for an EU fertilising product type and keep it together with the technical documentation at the disposal of the national authorities for 5 years after the EU fertilising product has been placed on the market. The EU declaration of conformity shall identify the EU fertilising product type for which it has been drawn up.

3.3. A copy of the EU declaration of conformity shall be made available to the relevant authorities upon request.

4. Authorised representative **U.K.**

The manufacturer's obligations set out in point 3 may be fulfilled by his or her authorised representative, on his or her behalf and under his or her responsibility, provided that they are specified in the mandate.

MODULE D1 – QUALITY ASSURANCE OF THE PRODUCTION PROCESS

1. Description of the module **U.K.**

Quality assurance of the production process is the conformity assessment procedure whereby the manufacturer fulfils the obligations laid down in points 2, 4, and 7, and ensures and declares on his or her sole responsibility that the EU fertilising products concerned satisfy the requirements of this Regulation that apply to them.

Status: Point in time view as at 05/06/2019.

Changes to legislation: There are currently no known outstanding effects for the Regulation (EU) 2019/1009 of the European Parliament and of the Council. (See end of Document for details)

2. Technical documentation **U.K.**
- 2.1. The manufacturer shall establish the technical documentation. The documentation shall make it possible to assess the EU fertilising product's conformity with the relevant requirements, and shall include an adequate analysis and assessment of the risk(s).
- 2.2. The technical documentation shall specify the applicable requirements and cover, as far as relevant for the assessment, the design, manufacture and intended use of the EU fertilising product. The technical documentation shall contain, where applicable, at least the following elements: **U.K.**
- (a) a general description of the EU fertilising product, the PFC corresponding to the claimed function of the EU fertilising product and description of the intended use,
 - (b) a list of component materials used, the CMCs as referred to in Annex II, to which they belong and information about their origin or manufacturing process,
 - (c) the EU declarations of conformity for the component EU fertilising products of the fertilising product blend,
 - (d) drawings, schemes, descriptions and explanations necessary for the understanding of the manufacturing process of the EU fertilising product, and, in relation to compost belonging to CMC 3 or digestate belonging to CMC 5, as defined in Annex II, a written description and a diagram of the production process, where each treatment, storage vessel and area is clearly identified,
 - (e) a specimen of the label or the leaflet, or both, referred to in Article 6(7) containing the information required in accordance with Annex III,
 - (f) a list of the harmonised standards referred to in Article 13, common specifications referred to in Article 14 and/or other relevant technical specifications applied. In the event of partly applied harmonised standards or common specifications, the technical documentation shall specify the parts which have been applied,
 - (g) results of calculations made, including the calculations to demonstrate conformity with point 5 of Part II of Annex I, examinations carried out, etc.,
 - (h) test reports,
 - (i) where the EU fertilising product contains or consists of derived products within the meaning of Regulation (EC) No 1069/2009, the commercial documents or health certificates required pursuant to that Regulation, and evidence that the derived products have reached the end point in the manufacturing chain within the meaning of that Regulation,
 - (j) where the EU fertilising product contains or consists of by-products within the meaning of Directive 2008/98/EC, technical and administrative evidence that the by-products comply with the criteria established by delegated act referred to in Article 42(7) of this Regulation, and with the national measures transposing Article 5(1) of Directive 2008/98/EC and, where applicable, implementing acts referred to in Article 5(2) or national measures adopted under Article 5(3) of that Directive, and
 - (k) where the EU fertilising product contains total chromium (Cr) above 200 mg/kg, information about the maximum quantity and exact source of total chromium (Cr).

Status: Point in time view as at 05/06/2019.

Changes to legislation: There are currently no known outstanding effects for the Regulation (EU) 2019/1009 of the European Parliament and of the Council. (See end of Document for details)

3. Availability of technical documentation **U.K.**

The manufacturer shall keep the technical documentation at the disposal of the relevant national authorities for 5 years after the EU fertilising product has been placed on the market.

4. Manufacturing **U.K.**

The manufacturer shall operate an approved quality system for production, final product inspection and testing of the EU fertilising products concerned as specified in point 5, and shall be subject to surveillance as specified in point 6.

5. Quality system **U.K.**

5.1. The manufacturer shall implement a quality system which shall ensure compliance of the EU fertilising products with the requirements of this Regulation that apply to them.

5.1.1. The quality system shall cover the quality objectives and the organisational structure with responsibilities and powers of the management with regard to product quality.

5.1.1.1. For compost belonging to CMC 3 and digestate belonging to CMC 5, as defined in Annex II, senior management of the manufacturer's organisation shall: **U.K.**

(a) ensure that sufficient resources (people, infrastructure, equipment) are available to create and implement the quality system;

(b) appoint a member of the organisation's management who shall be responsible for:

- ensuring that quality management processes are established, approved, implemented and maintained;
- reporting to senior management of the manufacturer on the performance of the quality management and any need for improvement;
- ensuring the promotion of awareness of customer needs and legal requirements throughout the manufacturer's organisation, and for making the personnel aware of the relevance and importance of the quality management requirements to meet the legal requirements of this Regulation;
- ensuring that each person whose duties affect the product quality is sufficiently trained and instructed; and
- ensuring the classification of the quality management documents mentioned under point 5.1.4;

(c) conduct an internal audit every year, or sooner than scheduled if triggered by any significant change that may affect the quality of the EU fertilising product; and

(d) ensure that appropriate communication processes are established within and outside the organisation and that communication take place regarding the effectiveness of the quality management.

5.1.2. The quality system shall cover the manufacturing, quality control and quality assurance techniques, processes and systematic actions.

5.1.2.1. For compost belonging to CMC 3 and digestate belonging to CMC 5, as defined in Annex II, the quality system shall ensure compliance with the composting and digestion process criteria specified in that Annex.

5.1.3. The quality system shall cover the examinations and tests to be carried out before, during and after manufacture with a specified frequency.

Status: Point in time view as at 05/06/2019.

Changes to legislation: There are currently no known outstanding effects for the Regulation (EU) 2019/1009 of the European Parliament and of the Council. (See end of Document for details)

5.1.3.1. For compost belonging to CMC 3 and digestate belonging to CMC 5, as defined in Annex II, the examinations and tests shall comprise the following elements: **U.K.**

- (a) The following information shall be recorded for each batch of input materials:
- (i) date of delivery;
 - (ii) amount by weight (or estimation based on the volume and density);
 - (iii) identity of the input material supplier;
 - (iv) input material type;
 - (v) identification of each batch and delivery location on site. A unique identification code shall be assigned throughout the production process for quality management purposes; and
 - (vi) in case of refusal, the reasons for the rejection of the batch and where it was sent.
- (b) Qualified staff shall carry out a visual inspection of each consignment of input materials and verify compatibility with the specifications of input materials laid down in CMC 3 and CMC 5 in Annex II.
- (c) The manufacturer shall refuse any consignment of any given input material where visual inspection raises any suspicion of:
- the presence of hazardous or damageable substances for the composting or digestion process or for the quality of the final EU fertilising product, or
 - incompatibility with the specifications laid down in CMC 3 and CMC 5 in Annex II, in particular by presence of plastics leading to exceedence of the limit value for macroscopic impurities.
- (d) The staff shall be trained on:
- potential hazardous properties that may be associated with input materials, and
 - features that allow hazardous properties and the presence of plastics to be recognised.
- (e) Samples shall be taken on output materials, to verify that they comply with the component material specifications for compost and digestate laid down in CMC 3 and CMC 5 in Annex II, and that the properties of the output material do not jeopardise the EU fertilising product's compliance with the relevant requirements in Annex I.
- (f) The output material samples shall be taken on a regular basis with at least the following frequency:

Annual input(tonnes)	Samples / year
≤ 3 000	1
3 001 – 10 000	2
10 001 – 20 000	3
20 001 – 40 000	4
40 001 – 60 000	5

Status: Point in time view as at 05/06/2019.

Changes to legislation: There are currently no known outstanding effects for the Regulation (EU) 2019/1009 of the European Parliament and of the Council. (See end of Document for details)

60 001 – 80 000	6
80 001 – 100 000	7
100 001 – 120 000	8
120 001 – 140 000	9
140 001 – 160 000	10
160 001 – 180 000	11
> 180 000	12

(g) If any tested output material sample fails one or more of the applicable limits specified in the relevant sections of Annexes I and II, the person responsible for quality management referred to in point 5.1.1.1(b) shall:

- (i) clearly identify the non-conforming output materials and their storage place,
- (ii) analyse the reasons of the non-conformity and take any necessary action to avoid its repetition,
- (iii) record in the quality records referred to in point 5.1.4 if reprocessing takes place, or if the output material is eliminated.

5.1.4. The quality system shall cover the manufacturer's quality records, such as inspection reports and test data, calibration data, qualification reports on the personnel concerned, etc.

5.1.4.1. For compost belonging to CMC 3 and digestate belonging to CMC 5, as defined in Annex II, the quality records shall demonstrate effective control of input materials, production, storage and compliance of input- and output materials with the relevant requirements of this Regulation. Each document shall be legible and available at its relevant place(s) of use, and any obsolete version shall be promptly removed from all places where it is used, or at least identified as obsolete. The quality management documentation shall at least contain the following information: **U.K.**

- (a) a title,
- (b) a version number,
- (c) a date of issue,
- (d) the name of the person who issued it,
- (e) records about the effective control of input materials,
- (f) records about the effective control of the production process,
- (g) records about the effective control of the output materials,
- (h) records of non-conformities,
- (i) reports on all accidents and incidents that occur to the site, their known or suspected causes and actions taken,
- (j) records of the complaints expressed by third parties and how they have been addressed,
- (k) a record of the date, type and topic of training followed by the persons responsible for the quality of the product,

Status: Point in time view as at 05/06/2019.

Changes to legislation: There are currently no known outstanding effects for the Regulation (EU) 2019/1009 of the European Parliament and of the Council. (See end of Document for details)

- (l) results of internal audit and actions taken, and
 - (m) results of external audit review and actions taken.
- 5.1.5. The quality system shall cover the means of monitoring the achievement of the required product quality and the effective operation of the quality system.
- 5.1.5.1. For compost belonging to CMC 3 and digestate belonging to CMC 5, as defined in Annex II, the manufacturer shall establish an annual internal audit program in order to verify the compliance of the quality system with the following components: **U.K.**
- (a) a procedure that defines the responsibilities and requirements for planning and conducting internal audits, establishing records and reporting results shall be established and documented. A report identifying the non-conformities to the quality scheme shall be prepared and all corrective actions shall be reported. The records of the internal audit shall be annexed to the quality management documentation;
 - (b) priority shall be given to non-conformities identified by external audits;
 - (c) each auditor shall not audit his or her own work;
 - (d) the management responsible for the area audited shall ensure that the necessary corrective actions are taken without undue delay;
 - (e) internal audit realised in the frame of another quality management system can be taken into account provided that it is completed by an audit of the requirements to this quality system.
- 5.1.6. All the elements, requirements and provisions adopted by the manufacturer shall be documented in a systematic and orderly manner in the form of written policies, procedures and instructions. The quality system documentation shall permit a consistent interpretation of the quality programmes, plans, manuals and records. It shall, in particular, contain an adequate description of all the quality management elements set out in points 5.1.1 to 5.1.5.
- 5.2. The manufacturer shall lodge an application for assessment of his or her quality system with the notified body of his or her choice, for the EU fertilising products concerned. The application shall include: **U.K.**
- the name and address of the manufacturer and, if the application is lodged by the authorised representative, his or her name and address as well,
 - a written declaration that the same application has not been lodged with any other notified body,
 - all relevant information for the EU fertilising product category envisaged,
 - the documentation concerning the quality system containing all the elements set out in point 5.1,
 - the technical documentation referred to in point 2.
- 5.3.1. The notified body shall assess the quality system to determine whether it satisfies the requirements referred to in point 5.1.
- 5.3.2. It shall presume conformity with those requirements in respect of the elements of the quality system that comply with the corresponding specifications of the relevant harmonised standard.
- 5.3.3. In addition to experience in quality management systems, the auditing team shall have at least one member with experience of evaluation in the relevant product field and

Status: Point in time view as at 05/06/2019.

Changes to legislation: There are currently no known outstanding effects for the Regulation (EU) 2019/1009 of the European Parliament and of the Council. (See end of Document for details)

- product technology concerned, and knowledge of the applicable requirements of this Regulation. The audit shall include an assessment visit to the manufacturer's premises. The auditing team shall review the technical documentation referred to in point 2 in order to verify the manufacturer's ability to identify the relevant requirements of this Regulation and to carry out the necessary examinations with a view to ensuring compliance of the EU fertilising product with those requirements.
- 5.3.4. The decision shall be notified to the manufacturer. The notification shall contain the conclusions of the audit and the reasoned assessment decision.
- 5.4. The manufacturer shall undertake to fulfil the obligations arising out of the quality system as approved and to maintain it so that it remains adequate and efficient.
- 5.5.1. The manufacturer shall keep the notified body that has approved the quality system informed of any intended change to the quality system.
- 5.5.2. The notified body shall evaluate any proposed changes and decide whether the modified quality system will continue to satisfy the requirements referred to in point 5.1 or whether reassessment is necessary.
- 5.5.3. It shall notify the manufacturer of its decision. The notification shall contain the conclusions of the examination and the reasoned assessment decision.
6. Surveillance under the responsibility of the notified body **U.K.**
- 6.1. The purpose of surveillance is to make sure that the manufacturer duly fulfils the obligations arising out of the approved quality system.
- 6.2. The manufacturer shall, for assessment purposes, allow the notified body access to the manufacture, inspection, testing and storage sites and shall provide it with all necessary information, in particular: **U.K.**
- the quality system documentation,
 - the technical documentation referred to in point 2,
 - the quality records, such as inspection reports and test data, calibration data, qualification reports on the personnel concerned.
- 6.3.1. The notified body shall carry out periodic audits to make sure that the manufacturer maintains and applies the quality system and shall provide the manufacturer with an audit report.
- 6.3.2. For compost belonging to CMC 3 and digestate belonging to CMC 5, as defined in Annex II, the notified body shall take and analyse output material samples during each audit, and the audits shall be carried out with the following frequency: **U.K.**
- (a) during the notified body's first year of surveillance of the plant in question: the same frequency as the sampling frequency indicated in the table included in point 5.1.3.1(f); and
 - (b) during the following years of surveillance: half the sampling frequency indicated in the table included in point 5.1.3.1(f).
- 6.4. In addition, the notified body may pay unexpected visits to the manufacturer. During such visits the notified body may, if necessary, carry out product tests, or have them carried out, in order to verify that the quality system is functioning correctly. The notified body shall provide the manufacturer with a visit report and, if tests have been carried out, with a test report.

Status: Point in time view as at 05/06/2019.

Changes to legislation: There are currently no known outstanding effects for the Regulation (EU) 2019/1009 of the European Parliament and of the Council. (See end of Document for details)

7. CE marking and EU declaration of conformity **U.K.**
- 7.1. The manufacturer shall affix the CE marking and, under the responsibility of the notified body referred to in point 5.2, the latter's identification number to each individual packaging of the EU fertilising product that satisfies the applicable requirements of this Regulation or, where it is supplied without packaging, in a document accompanying the EU fertilising product.
- 7.2. The manufacturer shall draw up a written EU declaration of conformity for an EU fertilising product or type and keep it, together with the technical documentation at the disposal of the national authorities for 5 years after the EU fertilising product has been placed on the market. The EU declaration of conformity shall identify the EU fertilising product or type for which it has been drawn up.
- 7.3. A copy of the EU declaration of conformity shall be made available to the relevant authorities upon request.

8. Availability of quality system documentation **U.K.**

The manufacturer shall, for 5 years after the EU fertilising product has been placed on the market, keep at the disposal of the national authorities:

- the documentation referred to in point 5.1.6,
- the information on the changes referred to in points 5.5.1 and 5.5.2, as approved,
- the decisions and reports of the notified body referred to in points 5.5.3, 6.3.1 and 6.4.

9. Notified bodies' information obligation **U.K.**

- 9.1. Each notified body shall inform its notifying authority of quality system approvals issued or withdrawn, and shall, periodically or upon request, make available to its notifying authority the list of quality system approvals refused, suspended or otherwise restricted.
- 9.2. Each notified body shall inform the other notified bodies of quality system approvals which it has refused, withdrawn, suspended or otherwise restricted, and, upon request, of quality system approvals which it has issued.

10. Authorised representative **U.K.**

The manufacturer's obligations set out in points 3, 5.2, 5.5.1, 7 and 8 may be fulfilled by his or her authorised representative, on his or her behalf and under his or her responsibility, provided that they are specified in the mandate.

ANNEX V **U.K.**

EU Declaration of conformity (No XXX)⁽⁴⁹⁾

1. EU fertilising product (product-, batch-, or type- number):
2. Name and address of the manufacturer and, where applicable, its authorised representative:
3. This EU declaration of conformity is issued under the sole responsibility of the manufacturer.

Status: Point in time view as at 05/06/2019.

Changes to legislation: *There are currently no known outstanding effects for the Regulation (EU) 2019/1009 of the European Parliament and of the Council. (See end of Document for details)*

4. Object of the declaration (identification of the EU fertilising product allowing traceability; it may, where necessary for the identification of the EU fertilising product, include an image):
 5. The object of the declaration described above is in conformity with: **U.K.**
 - Regulation (EU) 2019/1009⁽⁵⁰⁾,
 - other Union harmonisation legislation where applicable:
 6. References to the relevant harmonised standards or to the common specifications used or references to the other technical specifications in relation to which conformity is declared:
 7. Where applicable, the notified body ... (name, number) performed ... (description of intervention) and issued the certificate or approval decision ... (number):
 8. Where applicable, annexed to this EU declaration of conformity are the EU declarations of conformity for the component EU fertilising products of the fertilising product blend.
 9. Additional information: **U.K.**
- Signed for and on behalf of:
(place and date of issue):
(name, function) (signature):

Status: Point in time view as at 05/06/2019.

Changes to legislation: *There are currently no known outstanding effects for the Regulation (EU) 2019/1009 of the European Parliament and of the Council. (See end of Document for details)*

- (1) [OJ C 389, 21.10.2016, p. 80.](#)
- (2) Position of the European Parliament of 27 March 2019 (not yet published in the Official Journal) and decision of the Council of 21 May 2019.
- (3) Regulation (EC) No 2003/2003 of the European Parliament and of the Council of 13 October 2003 relating to fertilisers ([OJ L 304, 21.11.2003, p. 1.](#))
- (4) Regulation (EC) No 765/2008 of the European Parliament and of the Council of 9 July 2008 setting out the requirements for accreditation and market surveillance relating to the marketing of products and repealing Regulation (EEC) No 339/93 ([OJ L 218, 13.8.2008, p. 30.](#))
- (5) Decision No 768/2008/EC of the European Parliament and of the Council of 9 July 2008 on a common framework for the marketing of products, and repealing Council Decision 93/465/EEC ([OJ L 218, 13.8.2008, p. 82.](#))
- (6) Regulation (EC) No 1069/2009 of the European Parliament and of the Council of 21 October 2009 laying down health rules as regards animal by-products and derived products not intended for human consumption and repealing Regulation (EC) No 1774/2002 (Animal by-products Regulation) ([OJ L 300, 14.11.2009, p. 1.](#))
- (7) Regulation (EC) No 178/2002 of the European Parliament and of the Council of 28 January 2002 laying down the general principles and requirements of food law, establishing the European Food Safety Authority and laying down procedures in matters of food safety ([OJ L 31, 1.2.2002, p. 1.](#))
- (8) Directive 2008/98/EC of the European Parliament and of the Council of 19 November 2008 on waste and repealing certain Directives ([OJ L 312, 22.11.2008, p. 3.](#))
- (9) Regulation (EC) No 1107/2009 of the European Parliament and of the Council of 21 October 2009 concerning the placing of plant protection products on the market and repealing Council Directives 79/117/EEC and 91/414/EEC ([OJ L 309, 24.11.2009, p. 1.](#))
- (10) Council Directive 86/278/EEC of 12 June 1986 on the protection of the environment, and in particular of the soil, when sewage sludge is used in agriculture ([OJ L 181, 4.7.1986, p. 6.](#))
- (11) Council Directive 89/391/EEC of 12 June 1989 on the introduction of measures to encourage improvements in the safety and health of workers at work ([OJ L 183, 29.6.1989, p. 1.](#))
- (12) Council Directive 91/676/EEC of 12 December 1991 concerning the protection of waters against pollution caused by nitrates from agricultural sources ([OJ L 375, 31.12.1991, p. 1.](#))
- (13) Directive 2000/60/EC of the European Parliament and of the Council of 23 October 2000 establishing a framework for Community action in the field of water policy ([OJ L 327, 22.12.2000, p. 1.](#))
- (14) Directive 2001/18/EC of the European Parliament and of the Council of 12 March 2001 on the deliberate release into the environment of genetically modified organisms and repealing Council Directive 90/220/EEC ([OJ L 106, 17.4.2001, p. 1.](#))
- (15) Regulation (EC) No 852/2004 of the European Parliament and of the Council of 29 April 2004 on the hygiene of foodstuffs ([OJ L 139, 30.4.2004, p. 1.](#))
- (16) Regulation (EC) No 882/2004 of the European Parliament and of the Council of 29 April 2004 on official controls performed to ensure the verification of compliance with feed and food law, animal health and animal welfare rules ([OJ L 165, 30.4.2004, p. 1.](#))
- (17) Regulation (EC) No 1907/2006 of the European Parliament and of the Council of 18 December 2006 concerning the Registration, Evaluation, Authorisation and Restriction of Chemicals (REACH), establishing a European Chemicals Agency, amending Directive 1999/45/EC and repealing Council Regulation (EEC) No 793/93 and Commission Regulation (EC) No 1488/94 as well as Council Directive 76/769/EEC and Commission Directives 91/155/EEC, 93/67/EEC, 93/105/EC and 2000/21/EC ([OJ L 396, 30.12.2006, p. 1.](#))
- (18) Commission Regulation (EC) No 1881/2006 of 19 December 2006 setting maximum levels for certain contaminants in foodstuffs ([OJ L 364, 20.12.2006, p. 5.](#))
- (19) Council Regulation (EC) No 834/2007 of 28 June 2007 on organic production and labelling of organic products and repealing Regulation (EEC) No 2092/91 ([OJ L 189, 20.7.2007, p. 1.](#))
- (20) Regulation (EC) No 1272/2008 of the European Parliament and of the Council of 16 December 2008 on classification, labelling and packaging of substances and mixtures, amending and repealing

Status: Point in time view as at 05/06/2019.

Changes to legislation: There are currently no known outstanding effects for the Regulation (EU) 2019/1009 of the European Parliament and of the Council. (See end of Document for details)

- Directives 67/548/EEC and 1999/45/EC, and amending Regulation (EC) No 1907/2006 (OJ L 353, 31.12.2008, p. 1).
- (21) Regulation (EU) No 98/2013 of the European Parliament and of the Council of 15 January 2013 on the marketing and use of explosives precursors (OJ L 39, 9.2.2013, p. 1).
- (22) Regulation (EU) No 1143/2014 of the European Parliament and of the Council of 22 October 2014 on the prevention and management of the introduction and spread of invasive alien species (OJ L 317, 4.11.2014, p. 35).
- (23) Regulation (EU) 2016/2031 of the European Parliament of the Council of 26 October 2016 on protective measures against pests of plants, amending Regulations (EU) No 228/2013, (EU) No 652/2014 and (EU) No 1143/2014 of the European Parliament and of the Council and repealing Council Directives 69/464/EEC, 74/647/EEC, 93/85/EEC, 98/57/EC, 2000/29/EC, 2006/91/EC and 2007/33/EC (OJ L 317, 23.11.2016, p. 4).
- (24) Directive (EU) 2016/2284 of the European Parliament and of the Council of 14 December 2016 on the reduction of national emissions of certain atmospheric pollutants, amending Directive 2003/35/EC and repealing Directive 2001/81/EC (OJ L 344, 17.12.2016, p. 1).
- (25) Regulation (EU) 2017/625 of the European Parliament and of the Council of 15 March 2017 on official controls and other official activities performed to ensure the application of food and feed law, rules on animal health and welfare, plant health and plant protection products, amending Regulations (EC) No 999/2001, (EC) No 396/2005, (EC) No 1069/2009, (EC) No 1107/2009, (EU) No 1151/2012, (EU) No 652/2014, (EU) 2016/429 and (EU) 2016/2031 of the European Parliament and of the Council, Council Regulations (EC) No 1/2005 and (EC) No 1099/2009 and Council Directives 98/58/EC, 1999/74/EC, 2007/43/EC, 2008/119/EC and 2008/120/EC, and repealing Regulations (EC) No 854/2004 and (EC) No 882/2004 of the European Parliament and of the Council, Council Directives 89/608/EEC, 89/662/EEC, 90/425/EEC, 91/496/EEC, 96/23/EC, 96/93/EC and 97/78/EC and Council Decision 92/438/EEC (Official Controls Regulation) (OJ L 95, 7.4.2017, p. 1).
- (26) Regulation (EU) No 1025/2012 of the European Parliament and of the Council of 25 October 2012 on European standardisation, amending Council Directives 89/686/EEC and 93/15/EEC and Directives 94/9/EC, 94/25/EC, 95/16/EC, 97/23/EC, 98/34/EC, 2004/22/EC, 2007/23/EC, 2009/23/EC and 2009/105/EC of the European Parliament and of the Council and repealing Council Decision 87/95/EEC and Decision No 1673/2006/EC of the European Parliament and of the Council (OJ L 316, 14.11.2012, p. 12).
- (27) OJ L 123, 12.5.2016, p. 1.
- (28) Regulation (EU) No 182/2011 of the European Parliament and of the Council of 16 February 2011 laying down the rules and general principles concerning mechanisms for control by Member States of the Commission's exercise of implementing powers (OJ L 55, 28.2.2011, p. 13).
- (29) OJ L 123, 12.5.2016, p. 1.
- (30) Council Regulation (EEC) No 315/93 of 8 February 1993 laying down Community procedures for contaminants in food (OJ L 37, 13.2.1993, p. 1).
- (31) Regulation (EC) No 396/2005 of the European Parliament and of the Council of 23 February 2005 on maximum residue levels of pesticides in or on food and feed of plant and animal origin and amending Council Directive 91/414/EEC (OJ L 70, 16.3.2005, p. 1).
- (32) Regulation (EC) No 470/2009 of the European Parliament and of the Council of 6 May 2009 laying down Community procedures for the establishment of residue limits of pharmacologically active substances in foodstuffs of animal origin, repealing Council Regulation (EEC) No 2377/90 and amending Directive 2001/82/EC of the European Parliament and of the Council and Regulation (EC) No 726/2004 of the European Parliament and of the Council (OJ L 152, 16.6.2009, p. 11).
- (33) Directive 2002/32/EC of the European Parliament and of the Council of 7 May 2002 on undesirable substances in animal feed (OJ L 140, 30.5.2002, p. 10).
- (34) The exclusion of a material from CMC 1 does not prevent it from being an eligible component material by virtue of another CMC stipulating different requirements. See, for instance, CMC 3 on compost, CMCs 4 and 5 on digestate, CMCs 8 and 9 on polymers, CMC 10 on derived products within the meaning of Regulation (EC) No 1069/2009 or CMC 11 on by-products within the meaning of Directive 2008/98/EC.

Status: Point in time view as at 05/06/2019.

Changes to legislation: There are currently no known outstanding effects for the Regulation (EU) 2019/1009 of the European Parliament and of the Council. (See end of Document for details)

- (35) In the case of a substance recovered in the European Union, this condition is fulfilled if the substance is the same, within the meaning of point (d)(i) of Article 2(7) of Regulation (EC) No 1907/2006, as a substance registered with a dossier containing the information here indicated, and if information is available to the fertilising product manufacturer within the meaning of point (d)(ii) of Article 2(7) of Regulation (EC) No 1907/2006.
- (36) In the case of an additive recovered in the European Union, this condition is fulfilled if the additive is the same, within the meaning of point (d)(i) of Article 2(7) of Regulation (EC) No 1907/2006, as a substance registered with a dossier containing the information here indicated, and if information is available to the fertilising product manufacturer within the meaning of point (d)(ii) of Article 2(7) of Regulation (EC) No 1907/2006.
- (37) Sum of naphthalene, acenaphthylene, acenaphthene, fluorene, phenanthrene, anthracene, fluoranthene, pyrene, benzo[a]anthracene, chrysene, benzo[b]fluoranthene, benzo[k]fluoranthene, benzo[a]pyrene, indeno[1,2,3-cd]pyrene, dibenzo[a,h]anthracene and benzo[ghi]perylene.
- (38) Sum of naphthalene, acenaphthylene, acenaphthene, fluorene, phenanthrene, anthracene, fluoranthene, pyrene, benzo[a]anthracene, chrysene, benzo[b]fluoranthene, benzo[k]fluoranthene, benzo[a]pyrene, indeno[1,2,3-cd]pyrene, dibenzo[a,h]anthracene and benzo[ghi]perylene.
- (39) In the case of an additive recovered in the European Union, this condition is fulfilled if the additive is the same, within the meaning of point (d)(i) of Article 2(7) of Regulation (EC) No 1907/2006, as a substance registered with a dossier containing the information here indicated, and if information is available to the fertilising product manufacturer within the meaning of point (d)(ii) of Article 2(7) of Regulation (EC) No 1907/2006.
- (40) Commission Regulation (EU) No 142/2011 of 25 February 2011 implementing Regulation (EC) No 1069/2009 of the European Parliament and of the Council laying down health rules as regards animal by-products and derived products not intended for human consumption and implementing Council Directive 97/78/EC as regards certain samples and items exempt from veterinary checks at the border under that Directive (OJ L 54, 26.2.2011, p. 1).
- (41) In the case of an additive recovered in the European Union, this condition is fulfilled if the additive is the same, within the meaning of point (d)(i) of Article 2(7) of Regulation (EC) No 1907/2006, as a substance registered with a dossier containing the information here indicated, and if information is available to the fertilising product manufacturer within the meaning of point (d)(ii) of Article 2(7) of Regulation (EC) No 1907/2006.
- (42) Sum of naphthalene, acenaphthylene, acenaphthene, fluorene, phenanthrene, anthracene, fluoranthene, pyrene, benzo[a]anthracene, chrysene, benzo[b]fluoranthene, benzo[k]fluoranthene, benzo[a]pyrene, indeno[1,2,3-cd]pyrene, dibenzo[a,h]anthracene and benzo[ghi]perylene.
- (43) Sum of naphthalene, acenaphthylene, acenaphthene, fluorene, phenanthrene, anthracene, fluoranthene, pyrene, benzo[a]anthracene, chrysene, benzo[b]fluoranthene, benzo[k]fluoranthene, benzo[a]pyrene, indeno[1,2,3-cd]pyrene, dibenzo[a,h]anthracene and benzo[ghi]perylene.
- (44) In the case of a substance recovered in the European Union, this condition is fulfilled if the substance is the same, within the meaning of point (d)(i) of Article 2(7) of Regulation (EC) No 1907/2006, as a substance registered with a dossier containing the information here indicated, and if information is available to the fertilising product manufacturer within the meaning of point (d)(ii) of Article 2(7) of Regulation (EC) No 1907/2006.
- (45) The table will be established by delegated acts referred to in Article 42(5).
- (46) The exclusion of a material from CMC 11 does not prevent it from being an eligible component material by virtue of another CMC stipulating different requirements. See, for instance, CMC 3 on compost, CMCs 4 and 5 on digestate, CMCs 8 and 9 on polymers or CMC 10 on derived products within the meaning of Regulation (EC) No 1069/2009.
- (47) The diameter of the disc must always correspond to the inside diameter of the cylinder.
- (48) NB: When the six peripheral lengths of cord are taut after assembly, the central cord must remain slightly slack.
- (49) It is optional for the manufacturer to assign a number to the EU declaration of conformity.
- (50) Regulation (EU) 2019/1009 of the European parliament and the Council of 5 June 2019 laying down rules on the making available on the market of EU fertilising products and amending Regulations

Status: Point in time view as at 05/06/2019.

Changes to legislation: There are currently no known outstanding effects for the Regulation (EU) 2019/1009 of the European Parliament and of the Council. (See end of Document for details)

(EC) No 1069/2009 and (EC) No 1107/2009 and repealing Regulation (EC) No 2003/2003 ([OJ L 170, 25.6.2019, p. 1](#)).

Status:

Point in time view as at 05/06/2019.

Changes to legislation:

There are currently no known outstanding effects for the Regulation (EU) 2019/1009 of the European Parliament and of the Council.