

EGGS : MARKETING OF,

THE MARKETING OF EGGS RULES (NORTHERN IRELAND), 1929,
DATED 23RD FEBRUARY, 1929, MADE BY THE MINISTRY OF
AGRICULTURE FOR NORTHERN IRELAND UNDER THE
MARKETING OF EGGS ACTS (NORTHERN IRELAND); 1924
TO 1928.

1929. No. 24.

The Ministry of Agriculture for Northern Ireland in the exercise of the powers conferred on it by the Marketing of Eggs Acts (Northern Ireland), 1924 to 1928, and of any other power in that behalf enabling it hereby makes the following Rules, that is to say :—

I. *Short Title.*

1. These Rules may be cited as the Marketing of Eggs Rules (Northern Ireland), 1929.

II. *Definitions.*

2. In these Rules unless the context shall require a different construction :—

- (1) The expression " Acts " shall mean the Marketing of Eggs Acts (Northern Ireland), 1924 to 1928.
- (2) The expression " the Ministry " shall mean the Ministry of Agriculture for Northern Ireland.
- (3) The expression " Eggs " shall mean British eggs (that is eggs produced in the United Kingdom of Great Britain and Northern Ireland) in shell of domestic fowl (hens and ducks).

III. *Licences.*

(1) An application for a licence to carry on business as a wholesale dealer in eggs in Northern Ireland shall be made in the form or to the effect stated in the First Schedule to these Rules, and the granting of a licence shall be conditional upon the completion and lodgment with the Ministry by the applicant of the undertaking set out on that form as respects compliance with the conditions of these Rules.

(2) An application for a licence must be accompanied by a statement showing :—

- (a) Whether the applicant intends to test, grade and pack consignments for despatch or to dispose of eggs ungraded to other wholesale dealers in Northern Ireland.
- (b) The facilities available for the conduct of the applicant's trade :—
 - (i) Dimensions and general description of building.
 - (ii) Equipment provided.

- (iii) Nature of supply, *i.e.*, whether by itinerant collection, by purchase at a specified address, by purchase in markets ; or by any combination of these methods.

IV. Premises.

(1) Premises used by a wholesale dealer for the purposes of the preparation of eggs for sale or consignment, shall afford to the satisfaction of the Ministry, sufficient and suitable facilities, having regard to the volume of business transacted thereat, for the proper testing, grading and packing of eggs and the storing of empty cases, packing material and cases of eggs awaiting consignment. Premises shall be adequately lighted and ventilated, be provided with dry floors and be kept in a clean, sanitary condition and free from objectionable odours, likely to contaminate the eggs.

(2) For the purpose of this section two classes of premises shall be recognised by the Ministry as follows :—

Class A. Premises in which eggs are tested, graded and packed in accordance with these Rules. These premises shall be reserved solely for such business.

Class B. Premises used by wholesale dealers for the purposes of their trade other than premises described above as Class A premises.

(3) No eggs sold or intended for sale may be removed from Class A premises unless they have been tested, graded and packed in accordance with these Rules. Eggs intended for preserving or pickling may be removed without being graded to premises registered under Section (2) of the Act of 1924.

(4) Recognition of Class A premises may be withheld, or if granted, may be cancelled by the Ministry where :—

- (a) Any extension, alteration or remodelling of the premises required by the Ministry has not been carried out or,
- (b) Such equipment as may be considered necessary by the Ministry for the proper conduct of the trade in connection with which it is proposed to use the premises has not been provided or,
- (c) The testing grading and packing is not being conducted in accordance with these Rules.

(5) Where recognition of premises as Class A premises is withheld or cancelled, the Ministry may recognise the premises as Class B premises.

(6) No eggs shall be graded in Class B premises, and in the case of a licensed wholesale dealer who is also the occupier of Class A premises, testing in Class B premises shall not relieve him from the obligation to test in Class A premises as prescribed by paragraph (3) of this Article.

(7) Licensed wholesale dealers who are owners of Class B premises only shall not sell eggs by wholesale unless to other wholesale dealers in Northern Ireland.

V. Cases.

(1) Cases used by wholesale dealers for the carriage of graded eggs in consignments of 300 and upwards shall be one or more of three types, viz. :—

No. 1 Standard Case,

No. 2 Standard Case,

No. 3 Standard Case (including No. 3 Standard Case (Special)) and shall be constructed in accordance with the specifications contained in the Second Schedule to these Rules.

Provided that the Ministry may for special classes of trade authorise the use of cases of types other than those specified.

(2) Cases, fillers and flats intended for the carriage of graded eggs to destinations outside Northern Ireland shall not have been used before for any purpose.

Provided that cases and fillers and flats (which were new in the first instance) in which eggs are cold-stored or chemically stored, or in which eggs intended for preserving or pickling have been delivered to premises registered for that purpose, may be used once for the subsequent carriage of such eggs to destinations outside Northern Ireland.

(3) Cases, fillers and flats used for the carriage of eggs within Northern Ireland shall be maintained in a condition of reasonable cleanliness and good order generally.

(4) No. 3 Standard Cases used for itinerant collection shall not subsequently be used for the carriage of eggs unless consigned to Class A premises.

VI. Testing.

(1) During the period commencing on the 1st May and ending 31st December, in each year, eggs intended for sale by wholesale (except a sale by a wholesale dealer who is the owner of Class B premises only, to another wholesale dealer), and eggs intended for deposit for preserving, cold-storing, chemical storing, or pickling at premises registered under the Act of 1924, shall be tested singly by means of an approved artificial light test within 48 hours prior to despatch from the premises of the wholesale dealer or to transference to registered premises.

(2) Such eggs as are found on test not to comply with the requirements in regard to quality laid down in this Article or in Article VIII *Seconds* shall be marked on the shell with the word *Reject* in letters not less than 1/16th inch in height; the word being contained in a half-inch circle.

(3) An egg (not being a preserved, cold-stored, chemically stored, or pickled egg) shall not be regarded as "Fresh" or

“New-Laid” if on being tested any one of the following characteristics is found to be present :—

- (a) The contents are opaque or black ;
- (b) The white is dull, cloudy or streaky, or the yolk cannot be distinguished—this condition usually indicates a broken or spread yolk, and the egg is known as “ spent ” ;
- (c) The yolk is distinctly darkened in appearance, flattened in shape and floating near to the shell ;
- (d) The yolk is anywhere in contact with the shell, under which conditions the egg is known as “ sided ”—contact is denoted by a spot on the inner side of the shell and also by the fact that, when the egg is turned quickly, it is observed that the yolk adheres to the shell ;
- (e) Blood spots or dark or mould spots are present under the shell.

(4) An egg shall be regarded as “ Fresh ” or “ New-Laid ” if on being tested all of the following characteristics are found to be present :—

(a) *Hen Eggs :*

Yolk .. Translucent or faintly visible to visible but not clearly visible and keeping near centre.

White .. Translucent and firm.

(b) *Duck Eggs :*

Yolk .. Visible to clearly visible.

Shell .. Clear.

(5) Notwithstanding the provisions of this Article, preserved, cold-stored, chemically stored or pickled eggs may be sold without testing immediately prior to despatch from registered premises provided, in addition to the markings prescribed in Section 3 of the Act of 1924, the eggs are invoiced “ W.A.F.” (with all faults) and the cases in which they are packed are marked in a legible and indelible manner with the letters “ W.A.F.” not less than 1½ inches long.

(6) Unless it can be shown to the satisfaction of the Ministry that preserved, cold-stored, chemically stored or pickled eggs will be tested prior to sale, cases must be marked “ W.A.F.” *before* withdrawal from registered premises.

VII. *Grading.*

(1) Eggs intended for sale by wholesale (unless to another wholesale dealer in Northern Ireland and despatched from Class B premises) shall be packed according to the following grades :—

Grade Designation.

Conditions as to Size, etc.

Special (18 lb.)

For hen eggs of uniform size weighing 18 lb. per 120. No twelve eggs in any 120 shall weigh less than 28 ozs.

<i>Special</i> (17 lb.)	For hen eggs of uniform size weighing 17 lb. per 120. No twelve eggs in any 120 shall weigh less than $26\frac{1}{2}$ ozs.
<i>Standard</i> ($15\frac{1}{2}$ lb.)	For hen eggs of uniform size weighing $15\frac{1}{2}$ lb. per 120. No twelve eggs in any 120 shall weigh less than 24 ozs.
<i>Selected</i> (14 lb.)	For hen eggs of uniform size weighing 14 lb. per 120. No twelve eggs in any 120 shall weigh less than $21\frac{1}{2}$ ozs.
<i>Smalls</i> ..	For hen eggs too small for inclusion in the <i>Selected</i> (14 lb.) Grade and weighing less than $21\frac{1}{2}$ oz. per doz.
<i>Ducks</i> ..	For duck eggs of reasonably uniform size.

(2) Each egg in a case shall approximate closely to the general average of the eggs in that case. The top layer of eggs in any case shall be fairly representative of the bulk in size, colour and appearance.

(3) Subject to the special provisions in the Acts relating to preserved, cold-stored, chemically stored, or pickled eggs, only "Fresh" or "New-Laid" eggs shall be included in any of the grades specified herein.

(4) Hen eggs and duck eggs shall not be packed in the same case.

(5) Eggs with weak, cracked, chipped, dented or broken shells shall not be included in any of the grades set out in this Article.

VIII. *Seconds.*

Eggs which, on being tested, do not comply with the standards laid down for "Fresh," or "New-Laid" eggs (see Art. VI (4)) but which have the following characteristics :—

White .. Translucent but may be weak ;

Yolk .. Visible, swinging freely but clear of side ;

may be sold by licensed wholesale dealers, provided each egg is stamped on the shell with the word "*Seconds*" in letters not less than $1/16$ th inch in height, the word being contained in a half inch circle. These eggs need not be graded but the cases used for their consignment, which shall be marked with the word "*Seconds*" in letters not less than $\frac{3}{4}$ inch long, shall comply with the requirements of art. V (*Cases*).

IX. *Packing.*

(1) The testing, grading and packing of eggs intended for sale by wholesale shall, without exception, be conducted under cover.

(2) In preparing consignments for despatch the packing material used for Standard Cases Nos. 1 and 2 shall consist of clean dry straw or wood-wool of suitable quality, free from objectionable odour. Sufficient packing material shall be used between the layers and under the lowest and above the uppermost layer of eggs packed in these cases to ensure safety in transit under normal conditions.

(3) Empty egg cases, packing material, and cases of packed eggs shall be stored in premises which afford adequate protection from damp and adverse weather conditions and are free from objectionable odours, likely to contaminate the eggs.

(4) Cases in transit must at all times be protected from adverse weather conditions and if in an open or uncovered vehicle such cases must be protected by effective waterproof covers.

(5) All graded eggs intended for consignment in cases shall be hand packed in such cases.

(6) Grass, hay, musty straw or rushes must not in any circumstances be used for packing when storing eggs or when forwarding eggs to market.

X. *Cold Stored, Chemically Stored, Pickled and Preserved Eggs.*

(1) Eggs which have been preserved by cold storage or chemical storage are hereby exempted from the provisions of Section 3 (1) of the Marketing of Eggs Act (Northern Ireland), 1928.

(2) After 28th February, 1929, any eggs to which Section 3 of the Marketing of Eggs Act, Northern Ireland, 1928, applies, that is to say, eggs preserved by any process other than the processes mentioned in the following paragraph, shall be marked conspicuously and legibly on the shell with the word "*Preserved*" in letters not less than 1/16th inch in height, the word being enclosed in a circle of not less than ½ inch in diameter.

(3) If and so long as any Order in Council under Section 2 of the Merchandise Marks Act, 1926, is in force prohibiting the sale or exposure for sale in the United Kingdom of imported eggs unless they bear an indication of origin, British eggs shall, before deposit in cold storage or chemical storage, in the former case, be marked conspicuously and legibly on the shell with the word "*Chilled*" or with the words "*Cold Stored*," and in the latter case with the word "*Sterilised*," the letters being in each case not less than 1/16th inch in height and the word or words being enclosed in a circle of not less than ½ inch diameter.

Any British eggs in cold storage or chemical storage at the date when this provision comes into force shall be marked in the prescribed manner before removal from the premises.

(4) A *cold-stored* egg showing any of the following characteristics shall not be included in any case of tested cold stored eggs :—

- (a) The contents are opaque or black ;
- (b) The yolk is anywhere in contact with the shell ;
- (c) The white has become tinted.

(5) A *pickled* egg showing any of the following characteristics shall not be included in any case of tested pickled eggs :—

- (a) The contents are opaque or black ;
- (b) Portion of the white is opaque in appearance similar to a slightly boiled egg ;
- (c) The white is cloudy or discoloured.

(6) Eggs intended for cold storage or chemical storage shall be graded in accordance with the terms of Article VII (*Grading*) prior to deposit in registered premises. Such eggs need not be regraded on withdrawal from registered premises, provided the original grading remains unaltered.

(7) Preserved and pickled eggs shall be graded on withdrawal from registered premises unless they were graded prior to deposit in such premises, the grading meantime remaining unaltered.

(8) Preserved, cold stored, chemically stored or pickled eggs shall not be included in any package for sale or consignment along with other eggs not so preserved, cold stored, chemically stored or pickled.

XI. *Registration of Premises.*

(1) An application for the registration of premises where eggs are preserved, cold-stored, chemically stored, or pickled shall be made in the form or to the effect stated in the Third Schedule to these Rules.

(2) The owner or occupier of any such registered premises shall keep a record (showing separately particulars as to preserved eggs, cold-stored eggs, chemically stored eggs, and pickled eggs) of the quantity and ownership of eggs deposited at the registered premises, the date of each deposit and the quantity and ownership of eggs removed from the premises and the date of each removal, together with the name and address of the consignee in the case of all eggs forwarded by the owner or occupier from such premises. Returns of the deposits and removals during any specified period shall be furnished to the Ministry by the owner or occupier within fourteen days from the receipt of a demand, in writing, from the Ministry.

(3) The owner or occupier shall also give notification to the Ministry of any proposed structural alterations in the premises.

XII. *Itinerant Collection of Eggs.*

(1) When itinerant collection is made the eggs shall forthwith be packed in cases of the type known in the trade as "filler" or "section" cases. The cases shall be marked "Collection Only," and the eggs in these cases shall at all times be carefully protected from adverse weather conditions.

(2) This provision shall extend to the itinerant collection of eggs for sale by retail save that the cases need not be marked "Collection Only."

XIII. *Washing of Eggs.*

Eggs intended for sale or consignment shall not be washed or steeped by or on behalf of a wholesale dealer.

XIV. *Marking of Cases.*

(1) All cases prepared for sale or consignment shall, before despatch from the premises of a wholesale dealer, be marked *on each end*, in a legible and indelible manner, with letters and/or numbers, not less than $\frac{3}{4}$ inch long indicating :—

- (a) The grade designation.
- (b) The quantity of eggs in the case.
- (c) The Licence Number of wholesale dealer.
- (d) The invoice reference and, by means of a code approved by the Ministry, the time of dispatch.

(2) In addition, the following words shall be marked in like manner *on the lid* of each case :—“ Eggs.—This Side Up. With Care.”

(3) These marking are additional to those prescribed in the Acts, in the case of preserved, cold-stored, chemically stored or pickled eggs.

(4) On application being made by any wholesale dealer the Ministry may specially approve of marking differing in size and placing from the foregoing.

XV. *Identification of Supplies.*

During the period commencing the 1st May and ending 31st December in each year every wholesale dealer shall maintain such a system of recording the receipt of his supplies of eggs as will enable him to prove to the satisfaction of the Ministry the name of the person from whom any particular lot of eggs was received.

XVI. *Inspections.*

Every wholesale dealer and every owner or occupier of registered premises shall be bound, at all times, to facilitate an Inspector of the Ministry in the discharge of his duty by affording such assistance and by furnishing such information as he may reasonably require for that purpose.

XVII. *Revocation of Previous Rules.*

The Marketing of Eggs (Northern Ireland) Rules, 1926 (Statutory Rules and Orders of Northern Ireland, number 28 of 1926), and the Marketing of Eggs (Northern Ireland) Amendment Rules, 1926 (Statutory Rules and Orders of Northern Ireland, number 64 of 1926), are hereby revoked but such revocation shall not :—

- (1) Affect the previous operation of those Rules or anything duly done or suffered thereunder ; or
- (2) Affect any right, privilege, obligation, or liability acquired, accrued or incurred thereunder ; or
- (3) Affect any penalty incurred in respect of any offence committed against those Rules ; or
- (4) Affect any investigation, legal proceeding or remedy in respect of any such right, privilege, obligation, liability or penalty as aforesaid ; and any such investigation, legal proceeding or remedy may be instituted, continued or enforced, and any such penalty may be imposed, as if these Rules had not been made.

XVIII. *Commencement.*

These Rules shall come into operation on the twenty-eighth day of February, 1929.

XIX. General.

The Ministry may from time to time rescind, amend or vary these Rules or any of them as occasion may require.

In Witness whereof the official seal of the Ministry of Agriculture, Northern Ireland, is hereunto affixed this twenty-third day of February, nineteen hundred and twenty-nine.

(L.S.)

James S. Gordon, Secretary.

FIRST SCHEDULE.

GOVERNMENT OF NORTHERN IRELAND. MINISTRY OF AGRICULTURE.

MARKETING OF EGGS ACTS (NORTHERN IRELAND), 1924 to 1928. FORM OF APPLICATION FOR A LICENCE TO CARRY ON THE BUSINESS OF WHOLESALE DEALER IN EGGS.

Give full Name and Address.

(1) I, We,

hereby apply for a Licence to carry on the business of wholesale dealer(s) in eggs.

Particulars of all premises used by applicant should be fully set out.

(2) The premises used for the purpose of the wholesale dealings in eggs in connection with which a Licence is now sought are situated at.....

Only one licence fee will be charged each applicant irrespective of the number of premises used.

(3) I, We, enclose herewith the sum of £..... being the fees prescribed by the above-mentioned Acts for one Licence (at £1 0s 0d., and.....certified copies thereof (at 2s. 6d. each).

In the case of Companies or Societies this application and undertaking should be signed by the Secretary or other responsible official.

(4) I, We, hereby undertake, in the event of a Licence being granted to me, us, to comply with such regulations as the Ministry may from time to time issue, respecting the conduct of wholesale dealings in eggs.

Signature of Applicant..... Full Postal Address,.....

Witness,..... Date,.....

To THE SECRETARY, MINISTRY OF AGRICULTURE, WELLINGTON PLACE, BELFAST.

SECOND SCHEDULE.

GOVERNMENT OF NORTHERN IRELAND. MINISTRY OF AGRICULTURE.

MARKETING OF EGGS ACTS (NORTHERN IRELAND), 1924 to 1928. SPECIFICATIONS FOR STANDARD CASES.

The internal measurements and the thickness of timber mentioned in the specifications for these cases represent minimum dimensions.

No. 1 STANDARD CASE (DIVISIBLE).

This case is designed for not more than 6 hhd. (720) hen eggs, the grade weight of which is 17 lb. or less, or 5 hhd. (600) hen eggs of the "Special" (18 lb.) grade, or 5 hhd. (600) duck eggs.

The following is a diagram of the case :—

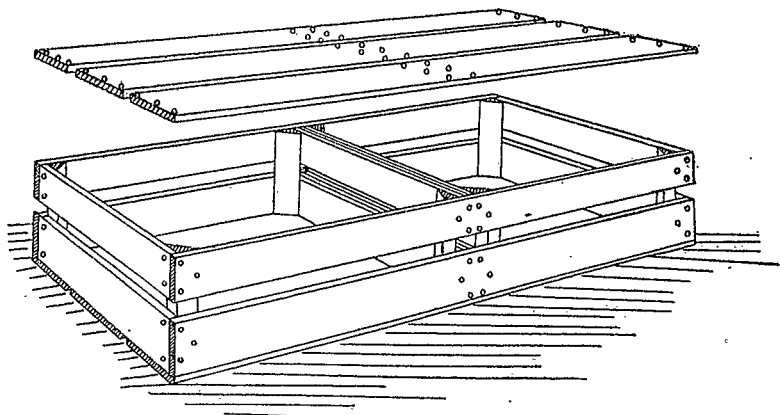

DESCRIPTION.

The case shall be made in two compartments, each compartment to hold 3 hhd. (360) hen eggs, the grade weight of which is 17 lb. or less, packed in three layers, each containing 10 rows of eggs with 12 eggs in each row ; or 2½ hhd. (300) hen eggs of the "Extras" (18 lb.) grade ; or 2½ hhd. (300) duck eggs, packed in three layers each containing 9 rows of eggs with 11 eggs in each row and 1 odd in each layer.

CONSTRUCTION.

The ends and sides of the case shall consist of two boards spaced horizontally and the case shall have eight corner angle posts.

INTERNAL DIMENSIONS. Each compartment to be not less than			TIMBER DIMENSIONS to be not less than			
Length.	Width.	Depth.	Top and Bottom boards. Wide Thick	Side boards. Wide Thick	End and centre boards. Wide Thick	Corner Angle posts 2" square, cut diagonally.
26"	23"	8"	4" ¾"	3" ¾"	3" ¾"	

Spacing between any two adjoining top, bottom, side and end boards nowhere to exceed 1 inch.

Saw space not exceeding ¼ inch must be provided between centre division boards.

ENDS AND CENTRE DIVISIONS.

The case shall have two centre divisions, each centre division and each end consisting of two boards ; no board shall be less than 23 inches by 3 inches by ¾ inch. If end boards of greater thickness than ¾ inch are used, care should be taken to ensure that the internal length of each compartment be not less than the required 26 inches.

SIDES.

The side boards shall be of the full outside length of the case ; no side board shall be less than 3 inches wide nor less than ¾ inch thick.

The side boards shall be so fixed that the top edges of the upper boards, and the bottom edges of the lower boards, will be level with the top and bottom edges, respectively, of the end boards.

TOPS AND BOTTOMS.

$\frac{3}{8}$ Top and bottom boards shall be not less than 4 inches wide and not less than inch thick.

The outer edges of the outside top boards and bottom boards, when nailed on, shall be flush with the outer sides of the side boards. The top and bottom boards shall be of the full outside length of the case, and be nailed into the end boards.

CORNER ANGLE POSTS.

All corner angle posts shall be of the full internal depth of the case, cut diagonally from a post 2 inches square. Square-cut corner posts may not be used.

TIMBER.

The wood used for the construction of the cases shall be of suitable strength, well-seasoned, clean, dry and free from bark, wane, feather and discolouration. All timber thicknesses specified are ACTUAL not nominal.

***NAILS AND NAILING.**

The nails used for making up Case No. 1 shall be of sizes not less than the following:—

For nailing sides to ends.	2 inch nails of 13 gauge.
" " tops and bottoms	
" " to ends and centre	
" " division boards	1 $\frac{1}{2}$ " " " "
For nailing corner posts	
" " to ends.	1 $\frac{1}{2}$ inch nails of 14 gauge.
" " sides to corner	
" " posts.	

Not less than two nails shall be "used" "each" "end" of each board, and an additional nail shall be used at each end of a board for every 3 inches or part of 3 inches by which the board exceeds 5 inches in width. This also applies to the nailing of the centre division boards. Each end of each side board shall be secured by at least two nails driven into the end boards and at least one nail driven into the corner post.

In nailing top and bottom boards to centre division boards, care should be exercised to place the nails in rows with at least $\frac{3}{8}$ inch space between the rows so as to allow for the free working of a saw when the case is being divided.

No. 2 STANDARD CASE.

This Case is designed for not more than 3 hhd. (360) hen eggs the grade weight of which is 17 lb. or less,
or 2 $\frac{1}{2}$ hhd. (300) hen eggs of the "Special" (18 lb.) grade.
or 2 $\frac{1}{2}$ hhd. (300) duck eggs.

The following is a diagram of the case:—

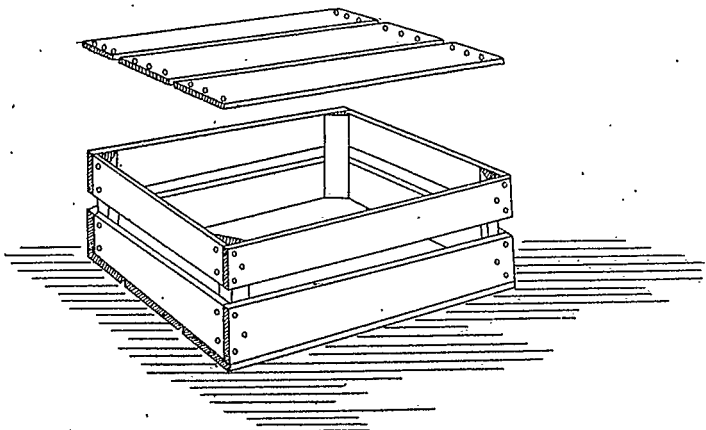

*NOTE.—It is recommended that cement coated wire nails be used and that, so far as possible, nails should be driven askew the grain of the wood.

DESCRIPTION.

The case shall be made in one compartment, to hold 3 hhd. (360) hen eggs, the grade weight of which is 17 lb. or less, packed in three layers, each containing 10 rows of eggs with 12 eggs in each row ; or 2½ hhd. (300) hen eggs of the "Extras" (18 lb.) grade ; or 2½ hhd. (300) duck eggs packed in 3 layers each containing 9 rows of eggs with 11 eggs in each row and 1 odd in each layer.

CONSTRUCTION.

This case, which is one-half of the No. 1 Standard Case, shall be constructed in like manner to that Case, with ends and sides consisting of two boards spaced horizontally, and with four corner angle posts.

All conditions specified for No. 1 Standard Case, with regard to the boards forming the ends, sides, tops and bottoms, as well as to the corner angle posts, spacing and nailing apply to the construction of this case.

INTERNAL DIMENSIONS to be not less than			TIMBER DIMENSIONS to be not less than			
Length.	Width.	Depth.	Top and Bottom boards. Wide Thick	Side boards. Wide Thick	End boards. Wide Thick	Corner Angle posts 2" square, cut diagonally.
26"	23"	8"	4" ¾"	3" ¾"	3" ¾"	

Spacing between any two adjoining top, bottom, side and end boards nowhere to exceed 1 inch.

TIMBER.

The wood used for the construction of the cases shall be of suitable strength, well seasoned, clean, dry, and free from bark, wane, feather and discolouration. All timber thicknesses specified are ACTUAL not nominal.

NO. 3 STANDARD CASE.

This Case which is designed for 3 hhd. (360) graded hen eggs, the grade weight of which is less than 17 lb., is fitted with fillers.

The following is a diagram of the case :—

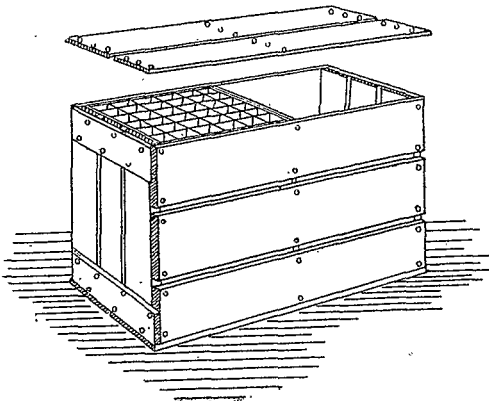

DESCRIPTION.

The case shall be made in two compartments, each compartment to take 180 eggs, packed in fillers with flats between the fillers.

INTERNAL DIMENSIONS. Each compartment to be not less than			TIMBER DIMENSIONS to be not less than			FILLERS. Each division to be	
Length.	Width.	Depth.	Top and bottom boards. Wide Thick	Side boards. Wide Thick	End and centre boards. Wide Thick	Depth.	Square.
11 $\frac{5}{8}$ "	11 $\frac{5}{8}$ "	13 $\frac{1}{2}$ "	3" $\frac{1}{16}$ "	4" $\frac{5}{16}$ "	3" $\frac{1}{16}$ "	2 $\frac{1}{2}$ "	1 $\frac{3}{4}$ "

ENDS.

Each end shall be not less than 13 $\frac{1}{2}$ inches deep by 11 $\frac{5}{8}$ inches wide by $\frac{1}{16}$ inch thick, and shall consist of three boards fixed upright, one of which shall be placed exactly in the middle of the end, and shall be not less than 4 inches wide. The end boards shall be nailed to cross battens measuring not less than 12 $\frac{1}{4}$ inches by 2 inches by $\frac{1}{16}$ inch thick, two on each end, fixed externally, one across the bottoms of the end boards and the other as close to the tops of the end boards as the construction of the lid permits. The battens shall be flush with the outer sides of the side boards.

CENTRE DIVISION.

To be made of boards not less than $\frac{1}{16}$ inch thick, and to be 13 $\frac{1}{2}$ inches deep and 11 $\frac{5}{8}$ inches wide. The division shall be fixed in the centre of the case secured by nails driven through the side and bottom boards.

TOPS AND BOTTOMS.

Each board shall be not less than $\frac{1}{16}$ inch thick and not less than 3 inches in width.

SIDES.

Each board shall be not less than $\frac{3}{16}$ inch thick and not less than 4 inches in width.

*SPACING.

The spacing between any two adjoining boards throughout the case shall nowhere exceed $\frac{3}{8}$ inch. When spacing is provided, between any two side boards, it shall be arranged so as to prevent any of the flats working through and the eggs coming in contact.

FILLERS.

The fillers shall be of wood pulp of calibre not less than .030, or other suitable material, 2 $\frac{1}{2}$ inches in depth, each division shall be 1 $\frac{3}{4}$ inches square; the extreme width of a filler to be 11 $\frac{1}{2}$ inches, a flat of the same material shall be placed between each pair of fillers. A flat shall be placed underneath the bottom filler and another above the top filler, thus using 10 fillers and 12 flats.

A layer of fine wood wool shall be placed underneath each lowest filler and above each uppermost filler. These layers shall be such that each will be not less than $\frac{1}{4}$ inch thick when the case is closed down. Parchment paper envelopes (or pads) containing wood wool may be used instead.

TIMBER.

The wood used for the construction of the cases shall be of suitable strength, well seasoned, clean, dry, and free from bark, wane, feather and discolouration. All timber thicknesses specified are ACTUAL not nominal.

NAILS AND NAILING.

Not less than two nails shall be used in each end of each board, including the cross battens and an additional nail shall be used at each end of a board for every 3 inches or part of 3 inches by which the board exceeds 5 inches in width.

The nails for making up Case No. 3 shall be not less than 1 $\frac{1}{2}$ inches of 14 gauge. It is recommended that cement coated wire nails be used and that, so far as possible, nails be driven askew the grain of the wood.

*NOTE.—When not intended for cold storing, spacing between boards is not essential.

No. 3 STANDARD CASE (SPECIAL).

This Case which is designed for 3 hhd. (360) graded hen eggs, the grade weight of which is 17 lb. or over, is fitted with fillers.

The specifications for this case are the same as for the foregoing (No. 3 Standard Case) with the exception of the following details:—

DESCRIPTION.

The case shall be made in two compartments, each compartment to take 180 eggs, packed in fillers with flats between the fillers.

INTERNAL DIMENSIONS. Each compartment to be not less than			TIMBER DIMENSIONS to be not less than			FILLERS. Each division to be	
Length.	Width.	Depth.	Top and bottom boards. Wide Thick	Side boards. Wide Thick	End and centre boards. Wide Thick	Depth.	Square.
12 $\frac{3}{8}$ "	12 $\frac{3}{8}$ "	13 $\frac{1}{2}$ "	3" $\frac{5}{16}$ "	4" $\frac{5}{16}$ "	3" $\frac{7}{16}$ "	2 $\frac{1}{2}$ "	1 $\frac{7}{8}$ "

ENDS.

Each end shall be not less than 13 $\frac{1}{2}$ inches deep by 12 $\frac{3}{8}$ inches wide by $\frac{7}{16}$ inch thick, and shall consist of three boards fixed upright, one of which shall be placed exactly in the middle of the end, and shall be not less than 4 inches wide. The end boards shall be nailed to cross battens measuring not less than 13 inches by 2 inches by $\frac{7}{16}$ inch thick, two on each end, fixed externally, one across the bottoms of the end boards and the other as close to the tops of the end boards as the construction of the lid permits. The battens shall be flush with the outer sides of the side boards.

CENTRE DIVISION.

To be made of boards not less than $\frac{7}{16}$ inch thick, and to be 13 $\frac{1}{2}$ inches deep, and 12 $\frac{3}{8}$ inches wide. The division shall be fixed in the centre of the case secured by nails driven through the side and bottom boards.

FILLERS.

The fillers shall be of wood pulp of calibre not less than .030, or other suitable material, 2 $\frac{1}{2}$ inches in depth, each division shall be 1 $\frac{7}{8}$ inches square; the extreme width of a filler to be 12 $\frac{1}{4}$ inches, a flat of the same material shall be placed between each pair of fillers. A flat shall be placed underneath the bottom filler and another above the top filler, thus using 10 fillers and 12 flats.

A layer of fine wood wool shall be placed underneath each lowest filler and above each uppermost filler. These layers shall be such that each will be not less than $\frac{1}{4}$ inch thick when the case is closed down. Parchment paper envelopes (or pads) containing wood wool may be used instead.

THIRD SCHEDULE.

GOVERNMENT OF NORTHERN IRELAND.

MINISTRY OF AGRICULTURE.

MARKETING OF EGGS ACTS (NORTHERN IRELAND), 1924 TO 1928.

FORM OF APPLICATION FOR REGISTRATION OF PREMISES ON WHICH EGGS
ARE PRESERVED, COLD-STORED, CHEMICALLY STORED OR PICKLED.

I
We

being the owner(s)
occupier(s) of the premises, particulars of which are set out below
hereby apply for registration of the said premises under Section 2 of the
Marketing of Eggs Act (Northern Ireland), 1924.

PREMISES.		Particulars of trade carried on therein, i.e., Preserving, Cold- Storing, Chemically Storing or Pickling.
No. Street and Town.	Exact location of portions used for trade.	

Signed.....

Address.....

To

The Secretary,
Ministry of Agriculture,
Wellington Place,
Belfast.

Date.....19....

EXCHEQUER AND FINANCIAL PROVISIONS.**Reserve Fund : Capital Liabilities.**

MADE BY THE MINISTRY OF FINANCE UNDER SUB-SECTION 2 OF
SECTION 2 OF THE EXCHEQUER AND FINANCIAL PRO-
VISIONS ACT (NORTHERN IRELAND), 1923 (13 GEO. 5, CAP 4.).

1929. No. 106.

WHEREAS it is provided by Section 2 of the Exchequer and
Financial Provisions Act (Northern Ireland), 1923, that the
annual surplus within the meaning of that section shall be applied
(in priority to its application to other purposes) towards the
reduction, by means of a reserve fund or sinking fund to be
created and applied in accordance with the prescribed Regulations,
of capital liabilities in connection with the public debt of Northern
Ireland.