

Trade Scholarships.

REGULATIONS, DATED 14TH JANUARY, 1930, MADE BY THE MINISTER OF EDUCATION FOR NORTHERN IRELAND, UNDER SECTION 99 OF THE EDUCATION ACT (NORTHERN IRELAND), 1923, AND LAID BEFORE PARLIAMENT IN ACCORDANCE WITH THAT SECTION OF THE ACT AFORESAID."

1930. No. 7.

1. These Regulations may be cited as the "Trade Scholarships Regulations, 1927, Amending Regulations, No. 1, 1930."

2. In paragraph (3) of Regulation 12 of the Trade Scholarships Regulations, 1927, the word "September" is hereby substituted for the word "June."

3. These Amending Regulations shall take and have effect as from 1st February, 1930, and shall thenceforth be construed with and as forming part of the Trade Scholarships Regulations, 1927.

Given under the Seal of the Ministry of Education for Northern Ireland, this 14th day of January, 1930.

(L.S.)

A. N. Bonaparte Wyse,
Secretary.

EGGS : MARKETING OF.

THE MARKETING OF EGGS RULES (NORTHERN IRELAND), 1930, DATED 2ND JUNE, 1930, MADE BY THE MINISTRY OF AGRICULTURE FOR NORTHERN IRELAND UNDER THE MARKETING OF EGGS ACTS (NORTHERN IRELAND), 1924 TO 1928.

1930. No. 72.

The Ministry of Agriculture for Northern Ireland in the exercise of the powers conferred on it by the Marketing of Eggs Acts (Northern Ireland), 1924 to 1928, and of any other power in that behalf enabling it hereby makes the following Rules, that is to say :—

I. *Short Title.*

1. These Rules may be cited as the Marketing of Eggs Rules (Northern Ireland), 1930.

II. *Definitions.*

2. In these Rules unless the context shall require a different construction :—

- (1) The expression "Acts" shall mean the Marketing of Eggs Acts (Northern Ireland), 1924 to 1928.
- (2) The expression "the Ministry" shall mean the Ministry of Agriculture for Northern Ireland.
- (3) The expression "Eggs" shall mean British eggs (that is, eggs produced in the United Kingdom of Great

Britain and Northern Ireland) in shell of domestic fowl (hens and ducks).

- (4) The expression "Carrying Company" shall mean any company, body or person carrying eggs for hire or reward.

III. Licences.

(1) An application for a licence to carry on business as a wholesale dealer in eggs in Northern Ireland shall be made in the form or to the effect stated in the First Schedule to these Rules, and the granting of a licence shall be conditional upon the completion and lodgment with the Ministry by the applicant of the undertaking set out on that form as respects compliance with the conditions of these Rules.

(2) An application for a licence must be accompanied by a statement showing :—

- (a) Whether the applicant intends to test, grade and pack consignments for despatch or to dispose of eggs ungraded to other licensed wholesale dealers in Northern Ireland.
- (b) The facilities available for the conduct of the applicant's trade :—
- (i) Dimensions and general description of building.
 - (ii) Equipment provided.
 - (iii) Nature of supply, *i.e.*, whether by itinerant collection, by purchase at a specified address, by purchase in markets ; or by any combination of these methods.

IV. Premises.

(1) Premises used by a licensed wholesale dealer for the purposes of the preparation of eggs for sale or consignment shall afford to the satisfaction of the Ministry sufficient and suitable facilities, having regard to the volume of business transacted thereat, for the proper testing, grading and packing of eggs and the storing of empty cases, packing material and cases of eggs awaiting consignment. Premises shall be adequately lighted and ventilated, be provided with dry floors and be kept in a clean, sanitary condition and free from objectionable odours likely to contaminate the eggs.

(2) For the purpose of this Article two classes of premises shall be recognised by the Ministry as follows :—

Class A. Premises in which eggs are tested, graded and packed in accordance with these Rules. These premises shall be reserved solely for such business.

Class B. Premises used by licensed wholesale dealers for the purposes of their trade other than premises described above as Class A premises.

(3) Eggs sold or intended for sale may not be removed from Class A premises unless they have been tested, graded and packed in accordance with these Rules. Eggs intended for

preserving or pickling may be removed without being graded to premises registered under Section 2 of the Act of 1924.

Provided that on application being made by a licensed wholesale dealer who is the owner or occupier of Class A premises the Ministry may, during the period commencing 1st January and ending 30th April in each year, specially authorise the applicant to transfer ungraded eggs from one Class A premises to another Class A premises owned or occupied by him, such eggs to be packed in cases marked "Collection Only." These cases may be of any of the types prescribed by these Rules.

(4) Recognition of Class A premises may be withheld or, if granted, may be cancelled by the Ministry where :—

- (a) Any extension, alteration or remodelling of the premises required by the Ministry has not been carried out, or
- (b) Such equipment as may be considered necessary by the Ministry for the proper conduct of the trade in connection with which it is proposed to use the premises has not been provided, or
- (c) The testing, grading and packing is not being conducted in accordance with these Rules.

(5) Where recognition of premises as Class A premises is withheld or cancelled the Ministry may recognise the premises as Class B premises.

(6) Eggs shall not be graded in Class B premises, and in the case of a licensed wholesale dealer who is also the owner or occupier of Class A premises testing in Class B premises shall not relieve him from the obligation to test in Class A premises as prescribed by paragraph (3) of this Article.

Provided that on application being made by a licensed wholesale dealer who is the owner or occupier of both Class A premises and Class B premises the Ministry may, during the period commencing 1st January and ending 30th April in each year, specially authorise the applicant to prepare duck eggs for sale or consignment on his Class B premises.

(7) A licensed wholesale dealer shall not remove eggs from any Class B premises to any Class A premises owned or occupied by him save in cases marked legibly and indelibly with the words "Collection Only" in block letters not less than 2 inches in height. These cases may be of any of the types prescribed by these Rules.

(8) Licensed wholesale dealers who are owners or occupiers of Class B premises only shall not sell eggs by wholesale unless to other licensed wholesale dealers in Northern Ireland.

V. Cases.

(1) Cases used by licensed wholesale dealers for the carriage of graded eggs in consignments of 300 and upwards shall be of one or more of three types, viz. :—

No. 1 Standard Case,

No. 2 Standard Case,

No. 3 Standard Case (including No. 3 Standard Case (Special)), and shall be constructed in accordance with the specifications contained in the Second Schedule to these Rules.

Provided that the Ministry may for special classes of trade authorise the use of cases of types other than those specified.

(2) Cases, fillers and flats intended for the carriage of graded eggs to destinations outside Northern Ireland shall not have been used before for any purpose.

Provided that cases, fillers and flats (which were new in the first instance) in which eggs are cold stored or chemically stored, or in which eggs intended for preserving or pickling have been delivered to premises registered for that purpose, may be used once for the subsequent carriage of such eggs to destinations outside Northern Ireland.

(3) Cases, fillers and flats used for the carriage of eggs within Northern Ireland shall be maintained in a condition of reasonable cleanliness and good order generally.

(4) No. 3 Standard Cases used for itinerant collection shall not subsequently be used for the carriage of eggs unless consigned to Class A premises.

VI. *Testing.*

(1) During the period commencing 1st May and ending 31st December in each year eggs intended for sale by wholesale (except a sale by a licensed wholesale dealer who is the owner or occupier of Class B premises only to another licensed wholesale dealer) and eggs intended for deposit for preserving, cold storing, chemical storing, or pickling at premises registered under the Act of 1924 shall be tested singly by means of an approved artificial light test within 48 hours prior to despatch from the premises of the licensed wholesale dealer or to transference to registered premises.

(2) Such eggs as are found on test not to comply with the requirements in regard to quality laid down in this Article or in Article VIII (*Seconds*) shall be marked on the shell with the word "*Reject*" in letters not less than $\frac{1}{8}$ inch in height, the word being contained in a circle of not less than $\frac{3}{4}$ inch in diameter.

(3) An egg (not being a preserved, cold stored, chemically stored, or pickled egg) shall not be regarded as "Fresh" or "New-Laid" if on being tested any of the following characteristics is found to be present :—

- (a) The contents are opaque or black ;
- (b) The white is dull, cloudy or streaky, or the yolk cannot be distinguished—this condition usually indicates a broken or spread yolk, and the egg is known as “ spent ” ;
- (c) The yolk is distinctly darkened in appearance, flattened in shape and floating near to the shell ;
- (d) The yolk is anywhere in contact with the shell, under which condition the egg is known as “ sided ”—contact is denoted by a spot on the inner side of the shell and also by the yolk adhering to the shell when the egg is turned quickly,
- (e) Blood spots or dark or mould spots are present under the shell.

(4) An egg shall be regarded as “ Fresh ” or “ New-Laid ” if on being tested all of the following characteristics are found to be present :—

(a) *Hen Eggs :*

Yolk .. Translucent or faintly visible to visible but not clearly visible and keeping near centre.

White .. Translucent and firm.

(b) *Duck Eggs :*

Yolk .. Visible to clearly visible.

Shell .. Clear.

(5) Notwithstanding the provisions of this Article, preserved, cold stored, chemically stored, or pickled eggs may be sold without testing immediately prior to despatch from registered premises provided that, in addition to the markings prescribed in Section 3 of the Act of 1924, the eggs are invoiced “ W.A.F.” (with all faults) and the cases in which they are packed are marked in a legible and indelible manner with the letters “ W.A.F.” not less than 1½ inches in height.

(6) Unless it can be shown to the satisfaction of the Ministry that preserved, cold stored, chemically stored, or pickled eggs will be tested prior to sale, cases must be marked “ W.A.F.” before withdrawal from registered premises.

VII. *Grading.*

(1) Eggs intended for sale by wholesale (unless to another licensed wholesale dealer in Northern Ireland and despatched

from Class B premises) shall be packed according to the following grades :—

<i>Grade Designation.</i>	<i>Conditions as to Size, etc.</i>
<i>Special (18 lb.)</i>	For hen eggs of uniform size weighing 18 lb. per 120. Any twelve eggs in any 120 shall weigh not less than 28 oz.
<i>Special (17 lb.)</i>	For hen eggs of uniform size weighing 17 lb. per 120. Any twelve eggs in any 120 shall weigh not less than 26½ oz.
<i>Standard (15½ lb.)</i>	For hen eggs of uniform size weighing 15½ lb. per 120. Any twelve eggs in any 120 shall weigh not less than 24 oz.
<i>Selected (14 lb.)</i>	For hen eggs of uniform size weighing 14 lb. per 120. Any twelve eggs in any 120 shall weigh not less than 21½ oz.
<i>Smalls</i> ..	For hen eggs too small for inclusion in the <i>Selected</i> (14 lb.) Grade and weighing less than 21½ oz. per doz.
<i>Ducks</i> ..	For duck eggs of reasonably uniform size.

(2) Each egg in a case shall approximate closely to the general average of the eggs in that case. The top layer of eggs in any case shall be fairly representative of the bulk in size, colour and appearance.

(3) Subject to the special provisions in the Acts relating to preserved, cold stored, chemically stored, or pickled eggs, only "Fresh" or "New-Laid" eggs shall be included in any of the grades specified herein.

(4) Hen eggs and duck eggs shall not be packed in the same case.

(5) Eggs with weak, cracked, chipped, dented or broken shells shall not be included in any of the grades specified herein.

VIII. *Seconds.*

Eggs which, on being tested, do not comply with the standards laid down for "Fresh" or "New-Laid" eggs (see Article VI (4)) but which have the following characteristics :—

Yolk .. Visible, swinging freely but clear of side ;
 White .. Translucent but may be weak ;

may be sold by licensed wholesale dealers, provided each egg is marked on the shell with the word "*Second*" in letters not less than $\frac{1}{8}$ inch in height, the word being contained in a circle of not less than $\frac{3}{4}$ inch in diameter. These eggs need not be graded but the cases used for their consignment, which shall be marked in a legible and indelible manner with the word "*Seconds*" in letters not less than $\frac{3}{4}$ inch in height, shall comply with the requirements of Article V (*Cases*).

IX. *Packing.*

(1) Where eggs are purchased for resale, whether by wholesale or retail, and the eggs are actually tendered by the vendor the eggs shall not be exposed by the vendor nor packed for removal by the purchaser save under cover.

Provided that this provision shall not apply to the purchase of eggs during itinerant collection.

(2) The testing, grading and packing of eggs intended for sale by wholesale shall, without exception, be conducted under cover.

(3) In preparing consignments for despatch the packing material used for Standard Cases Nos. 1 and 2 shall consist of clean dry straw or wood-wool of suitable quality, free from objectionable odour. Sufficient packing material shall be used between the layers and under the lowest and above the uppermost layer of eggs packed in these cases to ensure safety in transit under normal conditions.

(4) Empty egg cases, packing material, and cases of packed eggs shall be stored in premises which afford adequate protection from damp and adverse weather conditions and are free from objectionable odours likely to contaminate the eggs.

(5) Cases in transit must at all times be protected from adverse weather conditions and, if in an open or uncovered vehicle, such cases must be protected by effective waterproof covers.

(6) All graded eggs intended for consignment in cases shall be hand packed in such cases.

(7) Grass, hay, musty straw or rushes must not in any circumstances be used for packing when storing eggs or when forwarding eggs to market.

X. *Cold Stored, Chemically Stored, Pickled and Preserved Eggs.*

(1) Eggs which have been preserved by cold storage or chemical storage are hereby exempted from the provisions of Section 3 (1) of the Marketing of Eggs Act (Northern Ireland), 1928.

(2) Any eggs to which Section 3 of the Marketing of Eggs Act (Northern Ireland), 1928, applies, that is to say, eggs preserved by any process other than the processes mentioned in the following paragraph, shall be marked conspicuously and legibly on the shell with the word "*Preserved*" in letters not less than 1-16th inch in height, the word being enclosed in a circle of not less than $\frac{1}{2}$ inch in diameter.

(3) If and so long as any Order in Council under Section 2 of the Merchandise Marks Act, 1926, is in force prohibiting the sale or exposure for sale in the United Kingdom of imported eggs unless they bear an indication of origin, British eggs shall, before deposit in cold storage or chemical storage, in the former case, be marked conspicuously and legibly on the shell with the word "*Chilled*" or with the words "*Cold Stored*," and in the latter case

with the word "*Sterilised*," the letters being in each case not less than 1-16th inch in height and the word or words being enclosed in a circle of not less than $\frac{1}{2}$ inch in diameter.

(4) Where any eggs have been deposited in registered premises in contravention of the terms of the foregoing paragraph then, notwithstanding any action taken under the Acts in respect of any such contravention, the said eggs shall be marked in the prescribed manner before removal from the premises.

(5) A *cold stored* egg showing any of the following characteristics shall not be included in any case of tested cold stored eggs :—

- (a) The contents are opaque or black ;
- (b) The yolk is anywhere in contact with the shell ;
- (c) The white has become tinted.

(6) A *pickled* egg showing any of the following characteristics shall not be included in any case of tested pickled eggs :—

- (a) The contents are opaque or black ;
- (b) Portion of the white is opaque in appearance similar to a slightly boiled egg ;
- (c) The white is cloudy or discoloured.

(7) Eggs intended for cold storage or chemical storage shall be graded in accordance with the terms of Article VII (*Grading*) prior to deposit in registered premises. Such eggs need not be regraded on withdrawal from registered premises, provided that the original grading remains unaltered.

(8) Preserved and pickled eggs shall be graded on withdrawal from registered premises unless they were graded prior to deposit in such premises, the grading meantime remaining unaltered.

(9) Preserved, cold stored, chemically stored, or pickled eggs shall not be included in any package for sale or consignment along with other eggs not so preserved, cold stored, chemically stored, or pickled.

XI. *Registration of Premises.*

(1) An application for the registration of premises where eggs are preserved, cold stored, chemically stored, or pickled shall be made in the form or to the effect stated in the Third Schedule to these Rules.

(2) The owner or occupier of any such registered premises shall keep a record (showing separately particulars as to preserved eggs, cold stored eggs, chemically stored eggs, and pickled eggs) of the quantity and ownership of eggs deposited at the registered premises, the date of each deposit and the quantity and ownership of eggs removed from the premises and the date of each removal, together with the name and address of the consignee in the case of all eggs forwarded by the owner or occupier from such premises. Returns of the deposits and removals during any specified period shall be furnished to the Ministry by the owner or occupier within fourteen days from the receipt of a demand, in writing, from the Ministry.

(3) The owner or occupier shall give notification to the Ministry of any proposed structural alterations in the premises.

XII. *Itinerant Collection of Eggs.*

(1) When itinerant collection is made the eggs shall forthwith be packed in cases of the No. 3 Standard type. The cases shall be marked in a legible and indelible manner with the words "Collection Only" in block letters not less than 2 inches in height, and the eggs in these cases shall at all times be carefully protected from adverse weather conditions.

(2) This provision shall extend to the itinerant collection of eggs intended for sale by retail save that the cases need not be marked "Collection Only."

XIII. *Washing of Eggs.*

Eggs intended for sale or consignment shall not be washed or steeped by or on behalf of a licensed wholesale dealer.

XIV. *Marking of Cases.*

(1) All cases prepared for sale or consignment shall, before despatch from the premises of a licensed wholesale dealer, be marked *on each end*, in a legible and indelible manner, with letters and/or numbers, not less than $\frac{3}{4}$ inch in height, indicating:—

- (a) The grade designation.
- (b) The quantity of eggs in the case.
- (c) The Licence Number of wholesale dealer.
- (d) The invoice reference and, by means of a code approved by the Ministry, the date of packing.

These markings shall be shown on the cases in the manner indicated in the Fourth Schedule to these Rules.

(2) In addition, the following words shall be marked in like manner *on the lid* of each case:—"Eggs.—This Side Up. With Care."

(3) The foregoing markings are additional to those prescribed in the Acts in the case of preserved, cold stored, chemically stored, or pickled eggs.

(4) On application being made by any licensed wholesale dealer the Ministry may specially approve of marking differing in size and placing from the foregoing.

(5) In each case of graded eggs packed for despatch there shall be enclosed a docket on which shall be shown the licence number of the wholesale dealer on whose premises the eggs were packed, the initials or other reference which shall identify the person or persons who packed the eggs, the code reference to the date of packing and, during the period commencing 1st May and ending 31st December in each year, the initials or other reference which shall identify the person or persons who tested the eggs.

XV. *Identification of Supplies.*

During the period commencing 1st May and ending 31st December in each year every person who purchases eggs for resale, whether by wholesale or retail, from vendors who are not licensed wholesale dealers shall enclose in each case in which the said eggs are packed after purchase a docket on which shall be shown the name and address or the licence number of the purchaser, the date on which the purchase was made, the quantity

of eggs purchased and the name and address of the vendor. The docket shall be placed with the particular lot of eggs to which it refers in such manner as will enable the said lot to be clearly identified and shall not be removed until the eggs are unpacked for the purpose of testing.

XVI. *Inspections.*

Every licensed wholesale dealer and every owner or occupier of registered premises shall be bound, at all times, to aid an Inspector of the Ministry in the discharge of his duty by affording such assistance and by furnishing such information as he may reasonably require for that purpose.

XVII. *Transit.*

(1) Neither the Ministry nor any of its officers shall be liable for any loss or damage arising from the exercise by any such officer of the powers conferred upon him by the Acts and no action shall lie against the consignor, the carrying company or any other person for or on account of any such loss or damage as aforesaid.

(2) Nothing in the Acts or in these Rules shall be construed as authorising anything to be done to the prejudice of any power of a carrying company to secure payment of freight charges in respect of any consignment carried by it.

(3) Officers of the Ministry shall conform to such reasonable requirements of a carrying company as are necessary to prevent the working of the traffic being obstructed or interfered with.

(4) A licensed wholesale dealer shall not despatch consignments of eggs to Great Britain or the Isle of Man by a route which does not either pass through a Northern Ireland port or include the railway journey from Newry to the port of shipment unless he obtains a permit for the purpose from the Ministry. An application for a permit shall be forwarded by the applicant so as to reach the Ministry's offices at least three days before the date on which it is proposed to despatch the consignment, and shall give particulars of the name and address of the consignee, the number of each type of case in the consignment and the route by which the consignment is proposed to be despatched.

XVIII. *Revocation of Previous Rules.*

The Marketing of Eggs Rules (Northern Ireland), 1929, (Statutory Rules and Orders of Northern Ireland, Number 24 of 1929), are hereby revoked but such revocation shall not :—

- (1) Affect the previous operation of those Rules or anything duly done or suffered thereunder ; or
- (2) Affect any right, privilege, obligation, or liability acquired, accrued or incurred thereunder ; or
- (3) Affect any penalty incurred in respect of any offence committed against those Rules ; or
- (4) Affect any investigation, legal proceeding or remedy in respect of any such right, privilege, obligation,

liability or penalty as aforesaid; and any such investigation, legal proceeding or remedy may be instituted, continued or enforced, and any such penalty may be imposed, as if these Rules had not been made.

XIX. *Commencement.*

These Rules shall come into operation on the second day of June, 1930.

XX. *General.*

The Ministry may from time to time rescind, amend or vary these Rules or any of them as occasion may require.

In Witness whereof the official seal of the Ministry of Agriculture, Northern Ireland, is hereunto affixed this second day of June, nineteen hundred and thirty.

(L.S.)

James S. Gordon,
Secretary.

FIRST SCHEDULE.

GOVERNMENT OF NORTHERN IRELAND.

MINISTRY OF AGRICULTURE.

MARKETING OF EGGS ACTS (NORTHERN IRELAND), 1924 to 1928.

FORM OF APPLICATION FOR A LICENCE TO CARRY ON THE

BUSINESS OF WHOLESALE DEALER IN EGGS.

(1) $\frac{I}{We}$

Give full Name and Address.

hereby apply for a Licence to carry on the business of wholesale dealer(s) in eggs.

(2) The premises used for the purpose of the wholesale dealings in eggs in connection with which a Licence is now sought are situated at.....

Particulars of all premises used by applicant should be fully set out.

(3) $\frac{I}{We}$ enclose herewith the sum of £..... being the fees prescribed by the above-mentioned Acts for one Licence (at £1 0s 0d), and.....certified copies thereof (at 2s. 6d. each).

Only one licence fee will be charged each applicant irrespective of the number of premises used.

(4) $\frac{I}{We}$ hereby undertake, in the event of a Licence being granted to $\frac{me}{us}$, to comply with such regulations as the Ministry may from time to time issue, respecting the conduct of wholesale dealings in eggs.

Signature of Applicant.....

Full Postal Address.....

In the case of Companies or Societies this application and undertaking should be signed by the Secretary or other responsible official.

Witness.....

Date.....

To THE SECRETARY,
MINISTRY OF AGRICULTURE,
WELLINGTON PLACE,
BELFAST.

SECOND SCHEDULE.

GOVERNMENT OF NORTHERN IRELAND.
MINISTRY OF AGRICULTURE.MARKETING OF EGGS ACTS (NORTHERN IRELAND), 1924 TO 1928.
SPECIFICATIONS FOR STANDARD CASES.

The internal measurements and the thickness of timber mentioned in the specifications for these cases represent minimum dimensions.

No. 1 STANDARD CASE (DIVISIBLE).

This case is designed for not more than 6 hd. (720) hen eggs, the grade weight of which is 17 lb. or less,
or 5 hd. (600) hen eggs of the Special (18 lb.) grade,
or 5 hd. (600) duck eggs.

The following is a diagram of the case :—

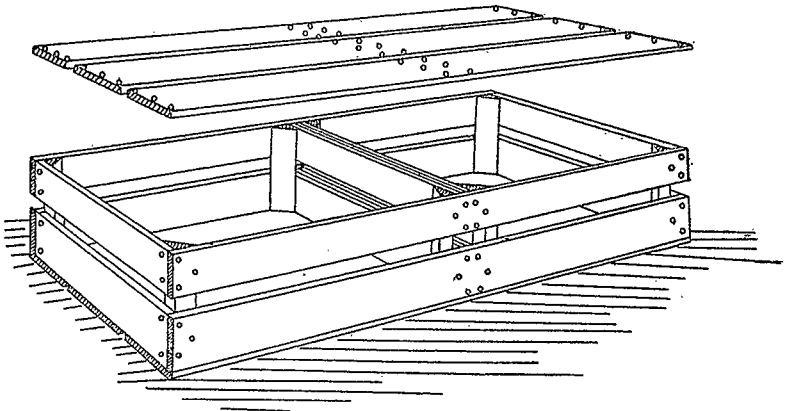

DESCRIPTION.

The case shall be made in two compartments, each compartment to hold 3 hd. (360) hen eggs, the grade weight of which is 17 lb. or less, packed in three layers, each containing 10 rows of eggs with 12 eggs in each row; or 2½ hd. (300) hen eggs of the Special (18 lb.) grade; or 2½ hd. (300) duck eggs, packed in three layers, each containing 9 rows of eggs with 11 eggs in each row and 1 odd in each layer.

CONSTRUCTION.

The ends and sides of the case shall each consist of two boards spaced horizontally and the case shall have eight corner angle posts.

INTERNAL DIMENSIONS. Each compartment to be not less than			TIMBER DIMENSIONS to be not less than			
Length.	Width.	Depth.	Top and Bottom boards. Wide Thick	Side boards. Wide Thick	End and centre boards. Wide Thick	Corner Angle posts 2" square, cut diagonally.
26"	23"	8"	4" ⅜"	3" ⅜"	3" ⅝"	

Spacing between any two adjoining top, bottom, side and end boards nowhere to exceed 1 inch.

Saw space not exceeding ¼ inch must be provided between centre division boards.

ENDS AND CENTRE DIVISIONS.

The case shall have two centre divisions, each centre division and each end consisting of two boards; no board shall be less than 23 inches by 3 inches by ⅝ inch. If end boards of greater thickness than ⅝ inch are used, care should be taken to ensure that the internal length of each compartment be not less than the required 26 inches.

SIDES.

The side boards shall be of the full outside length of the case ; each board shall be not less than 3 inches wide nor less than $\frac{3}{8}$ inch thick.

The side boards shall be so fixed that the top edges of the upper boards and the bottom edges of the lower boards will be level with the top and bottom edges, respectively, of the end boards.

TOPS AND BOTTOMS.

Top and bottom boards shall be not less than 4 inches wide and not less than $\frac{3}{8}$ inch thick.

The outer edges of the outside top boards and bottom boards, when nailed on, shall be flush with the outer sides of the side boards. The top and bottom boards shall be of the full outside length of the case and be nailed into the end boards.

CORNER ANGLE POSTS.

All corner angle posts shall be of the full internal depth of the case, cut diagonally from a post 2 inches square. Square-cut corner posts may not be used.

TIMBER.

The wood used for the construction of the cases shall be of suitable strength, well seasoned, clean, dry and free from bark, wane, feather and discolouration. All timber thicknesses specified are ACTUAL not nominal.

***NAILS AND NAILING.**

The nails used for making up Case No. 1 shall be of sizes not less than the following :—

For nailing sides to ends. 2 inch nails of 13 gauge.

“ “ tops and bottoms
to ends and centre
division boards $1\frac{3}{4}$ “ “ “ “

For nailing corner posts
to ends. $1\frac{1}{2}$ inch nails of 14 gauge.

“ “ sides to corner
posts. “ “ “ “

Not less than two nails shall be used in each end of each board, and an additional nail shall be used at each end of a board for every 3 inches or part of 3 inches by which the board exceeds 5 inches in width. This also applies to the nailing of the centre division boards. Each end of each side board shall be secured by at least two nails driven into the end boards and at least one nail driven into the corner post.

In nailing top and bottom boards to centre division boards care should be exercised to place the nails in rows with at least $\frac{3}{8}$ inch space between the rows so as to allow for the free working of a saw when the case is being divided.

No. 2 STANDARD CASE.

This Case is designed for not more than 3 hd. (360) hen eggs, the grade weight of which is 17 lb. or less,

or $2\frac{1}{2}$ hd. (300) hen eggs of the Special (18 lb.) grade.

or $2\frac{1}{2}$ hd. (300) duck eggs.

The following is a diagram of the case :—

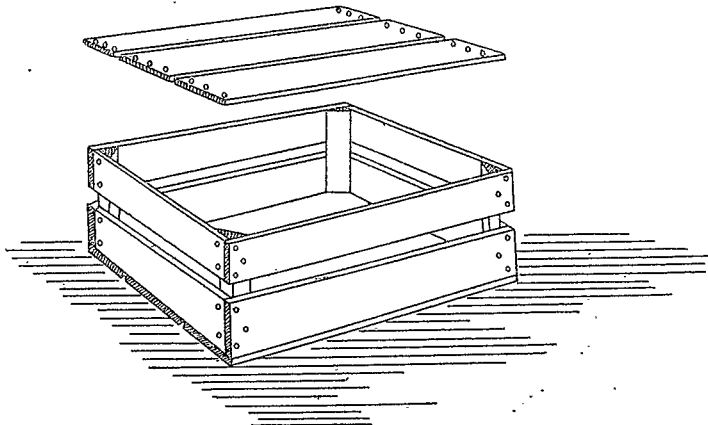

*NOTE.— It is recommended that cement coated wire nails be used and that, so far as possible, nails should be driven askew the grain of the wood.

DESCRIPTION.

The case shall be made in one compartment, to hold 3 hd. (360) hen eggs, the grade weight of which is 17 lb. or less, packed in three layers, each containing 10 rows of eggs with 12 eggs in each row; or 2½ hd. (300) hen eggs of the Special (13 lb.) grade; or 2¼ hd. (300) duck eggs, packed in 3 layers, each containing 9 rows of eggs with 11 eggs in each row and 1 odd in each layer.

CONSTRUCTION.

This case, which is one-half of the No. 1 Standard Case, shall be constructed in like manner to that Case, with ends and sides each consisting of two boards spaced horizontally, and with four corner angle posts.

All conditions specified for No. 1 Standard Case with regard to the boards forming the ends, sides, tops and bottoms, as well as to the corner angle posts, spacing and nailing, apply to the construction of this case.

INTERNAL DIMENSIONS to be not less than			TIMBER DIMENSIONS to be not less than			
Length.	Width.	Depth.	Top and Bottom boards. Wide Thick	Side boards. Wide Thick	End boards. Wide Thick	Corner Angle posts 2" square, cut diagonally.
26"	23"	8"	4" ¾"	3" ¾"	3" ½"	

Spacing between any two adjoining top, bottom, side and end boards nowhere to exceed 1 inch.

TIMBER.

The wood used for the construction of the cases shall be of suitable strength, well seasoned, clean, dry, and free from bark, wane, feather and discolouration. All timber thicknesses specified are ACTUAL not nominal.

No. 3 STANDARD CASE.

This Case which is designed for 3 hd. (360) hen eggs, the grade weight of which is less than 17 lb., is fitted with fillers.

The following is a diagram of the case:—

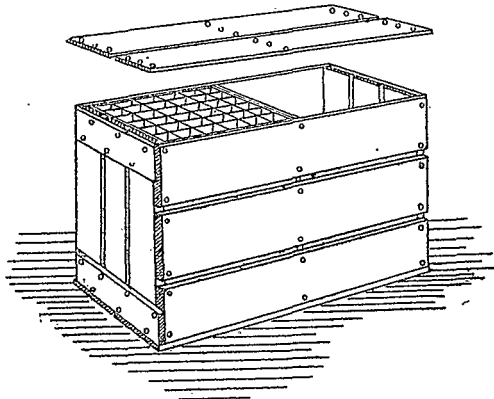

DESCRIPTION.

The case shall be made in two compartments, each compartment to take 180 eggs, packed in fillers with flats between the fillers.

INTERNAL DIMENSIONS. Each compartment to be not less than			TIMBER DIMENSIONS to be not less than					FILLERS. Each division to be	
Length.	Width.	Depth.	Top and bottom boards.	Side boards.	Centre division boards.	End boards.		Depth.	Square.
			Wide Thick	Wide Thick	Wide Thick	Centre board.	Other boards.		
11 $\frac{5}{8}$ "	11 $\frac{5}{8}$ "	13 $\frac{1}{2}$ "	3" 5/16"	4" 5/16"	3" 7/16"	4" 7/16"	3" 7/16"	2 $\frac{1}{2}$ "	1 $\frac{3}{4}$ "

ENDS.

Each end shall be not less than 13 $\frac{1}{2}$ inches deep by 11 $\frac{5}{8}$ inches wide by $\frac{7}{16}$ inch thick, and shall consist of three boards fixed upright, one of which shall be placed exactly in the middle of the end, and shall be not less than 4 inches wide. The end boards shall be nailed to cross battens measuring not less than 12 $\frac{1}{4}$ inches by 2 inches by $\frac{7}{16}$ inch thick, two on each end, fixed externally, one across the bottoms of the end boards and the other as close to the tops of the end boards as the construction of the lid permits. The battens shall be flush with the outer sides of the side boards.

CENTRE DIVISION.

To be made of boards not less than $\frac{7}{16}$ inch thick, and to be 13 $\frac{1}{2}$ inches deep and 11 $\frac{5}{8}$ inches wide. The division shall be fixed in the centre of the case secured by nails driven through the side and bottom boards.

TOPS AND BOTTOMS.

Each board shall be not less than $\frac{5}{16}$ inch thick and not less than 3 inches in width.

SIDES.

Each board shall be not less than $\frac{3}{8}$ inch thick and not less than 4 inches in width.

***SPACING.**

The spacing between any two adjoining boards throughout the case shall nowhere exceed $\frac{3}{8}$ inch. When spacing is provided between any two side boards, it shall be arranged so as to prevent any of the flats working through and the eggs coming in contact.

FILLERS.

The fillers shall be of wood pulp of calibre not less than .030, or such other material as may be approved by the Ministry, and be 2 $\frac{1}{2}$ inches in depth. Each division shall be 1 $\frac{3}{4}$ inches square and the extreme width of a filler shall be 11 $\frac{1}{2}$ inches. A flat of the same material shall be placed between each pair of fillers and also underneath the bottom filler and above the top filler, thus using 10 fillers and 12 flats.

A layer of fine wood wool shall be placed underneath each lowest filler and above each uppermost filler. These layers shall be such that each will be not less than $\frac{1}{4}$ inch thick when the case is closed down. Parchment paper envelopes (or pads) containing wood wool may be used instead.

TIMBER.

The wood used for the construction of the cases shall be of suitable strength, well seasoned, clean, dry, and free from bark, wane, feather and discolouration. All timber thicknesses specified are ACTUAL not nominal.

†NAILS AND NAILING.

Not less than two nails shall be used in each end of each board, including the cross battens, and an additional nail shall be used at each end of a board for every 3 inches or part of 3 inches by which the board exceeds 5 inches in width.

The nails for making up Case No. 3 shall be not less than 1 $\frac{1}{2}$ inches of 14 gauge.

*NOTE.—When not intended for cold storing, spacing between boards is not essential.

†It is recommended that cement coated wire nails be used and that so far as possible, nails be driven askew the grain of the wood.

No. 3 STANDARD CASE (SPECIAL).

This Case which is designed for 3 hd. (360) hen eggs, the grade weight of which is 17 lb. or over, is fitted with fillers.

The specifications for this case are the same as for the foregoing (No. 3 Standard Case) with the exception of the following details:—

DESCRIPTION.

The case shall be made in two compartments, each compartment to take 180 eggs, packed in fillers with flats between the fillers.

INTERNAL DIMENSIONS. Each compartment to be not less than			TIMBER DIMENSIONS to be not less than					FILLERS. Each division to be	
Length.	Width.	Depth.	Top and bottom boards.	Side boards.	Centre division boards.	End boards.		Depth.	Square.
			Wide Thick	Wide Thick	Wide Thick	Centre board. Wide Thick	Other boards. Wide Thick		
12 $\frac{3}{8}$ "	12 $\frac{3}{8}$ "	13 $\frac{1}{2}$ "	3" 5/16"	4" 5/16"	8" 7/16"	4" 7/16"	3" 7/16"	2 $\frac{1}{2}$ "	1 $\frac{7}{8}$ "

ENDS.

Each end shall be not less than 13 $\frac{1}{2}$ inches deep by 12 $\frac{3}{8}$ inches wide by $\frac{1}{4}$ inch thick, and shall consist of three boards fixed upright, one of which shall be placed exactly in the middle of the end, and shall be not less than 4 inches wide. The end boards shall be nailed to cross battens measuring not less than 13 inches by 2 inches by $\frac{1}{4}$ inch thick, two on each end, fixed externally, one across the bottoms of the end boards and the other as close to the tops of the end boards as the construction of the lid permits. The battens shall be flush with the outer sides of the side boards.

CENTRE DIVISION.

To be made of boards not less than $\frac{1}{4}$ inch thick, and to be 13 $\frac{1}{2}$ inches deep, and 12 $\frac{3}{8}$ inches wide. The division shall be fixed in the centre of the case secured by nails driven through the side and bottom boards.

FILLERS.

The fillers shall be of wood pulp of calibre not less than .030, or such other material as may be approved by the Ministry, and be 2 $\frac{1}{2}$ inches in depth. Each division shall be 1 $\frac{7}{8}$ inches square and the extreme width of a filler shall be 12 $\frac{1}{4}$ inches. A flat of the same material shall be placed between each pair of fillers, and also underneath the bottom filler and above the top filler, thus using 10 fillers and 12 flats.

A layer of fine wood wool shall be placed underneath each lowest filler and above each uppermost filler. These layers shall be such that each will be not less than $\frac{1}{4}$ inch thick when the case is closed down. Parchment paper envelopes (or pads) containing wood wool may be used instead.

THIRD SCHEDULE.

GOVERNMENT OF NORTHERN IRELAND.

MINISTRY OF AGRICULTURE.

MARKETING OF EGGS ACTS (NORTHERN IRELAND), 1924 TO 1928.

FORM OF APPLICATION FOR REGISTRATION OF PREMISES ON WHICH EGGS ARE PRESERVED, COLD STORED, CHEMICALLY STORED, OR PICKLED.

I
We

.....
being the owner(s) of the premises particulars of which are set out below
occupier(s)
hereby apply for registration of the said premises under Section 2 of the
Marketing of Eggs Act (Northern Ireland), 1924.

PREMISES.		Particulars of trade carried on therein, i.e., Preserving, Cold Storing, Chemically Storing, or Pickling.
No. Street and Town.	Exact location of portions used for trade.	

Signed.....

Address.....

To Date.....19.....

The Secretary,
Ministry of Agriculture,
Wellington Place,
Belfast.

FOURTH SCHEDULE.

DESIGN TO INDICATE THE MANNER IN WHICH THE MARKINGS PRESCRIBED BY ARTICLE XIV. (MARKING OF CASES) SHALL BE SHOWN ON THE ENDS OF STANDARD CASES.

Nos. 1 & 2 STANDARD CASES.

STANDARD (15½ lb.)	6 HD.
NORTHERN LIC.No.000 IRELAND	B.F. 17.

No. 3 STANDARD CASES.

STANDARD (15½ lb.)
NORTHERN LIC.No. 000 IRELAND
3 HD. B.F. 17.