



Merchant Shipping (Safety and Load Line Conventions) Act 1932

1932 CHAPTER 9

An Act to give effect to an International Convention for the Safety of Life at Sea, signed in London on the thirty-first day of May, nineteen hundred and twenty-nine, to give effect to an International Load Line Convention signed in London on the fifth day of July, nineteen hundred and thirty, and to amend the provisions of the Merchant Shipping Acts, 1894 to 1928, relating to passenger steamers, life-saving appliances, wireless telegraphy, load lines, timber cargoes, and other matters affected by the said Conventions. [17th March 1932]

WHEREAS a Convention (in this Act referred to as " the Safety Convention ") which is set out in the First Schedule to this Act, was signed on behalf of the Government of the United Kingdom in London on the thirty-first day of May, nineteen hundred and twenty-nine, for promoting safety of life at sea by establishing in common agreement uniform principles and rules directed thereto:

And whereas a Convention (in this Act referred to as " the Load Line Convention ") which is set out in the Second Schedule to this Act, was signed on behalf of the Government of the United Kingdom in London on the fifth day of July, nineteen hundred and thirty, for promoting safety of life and property at sea, by establishing in common agreement uniform principles and rules with regard to the limits to which ships on international voyages may be loaded:

And whereas it is expedient to give effect to the said Conventions and to amend the provisions of the Merchant Shipping Acts, 1894 to 1928, relating to passenger steamers, life-saving appliances, wireless telegraphy, load lines, timber cargoes and other matters affected by the said Conventions:

Be it therefore enacted by the King's most Excellent Majesty, by and with the advice and consent of the Lords Spiritual and Temporal, and Commons, in this present Parliament assembled, and by the authority of the same, as follows:—

PART I

SAFETY OF LIFE AT SEA.

Construction and Surveys.

1 Construction and survey regulations to implement Chapter II of Safety Convention.

- (1) The construction regulations applicable to passenger steamers plying on international voyages shall include such requirements as appear to the Board of Trade to implement the provisions relating to construction, machinery, equipment and marking of load lines which are contained in Chapter II of the Safety Convention and the Regulations referred to therein (except in so far as the said provisions are otherwise implemented by the Merchant Shipping Acts):

Provided that—

- (a) the Board may treat any passenger steamer constructed before the first day of July, nineteen hundred and thirty-one, (not being a steamer converted to passenger service on or after that date) as complying with any such requirement, if the Board are satisfied that such steps, if any, as are reasonable and practicable have been taken to make the steamer comply with that requirement;
 - (b) the Board may, as respects passenger steamers plying on any international coasting voyage, modify any such requirement, if and to the extent that they are satisfied that the risks incurred by passenger steamers plying on that voyage are such as to make it unreasonable or unnecessary to require steamers so plying to comply with that requirement;
 - (c) the Board may, as respects steamers for the time being engaged in any passenger trade in which they are employed in the carriage of large numbers of unberthed passengers, modify any such requirement, if they are satisfied that compliance with that requirement by steamers so engaged is impracticable and to the extent that they are satisfied that modifications are required by the conditions of the trade; and
 - (d) the Board may, as respects any steamer plying on short international voyages, modify any of the requirements of the construction regulations which implement the provisions of the Safety Convention contained in Regulations IX, X, XV and XIX thereof, if and to the extent that the Board are satisfied that that requirement is neither reasonable nor practicable in the case of that steamer.
- (2) If it appears to the Board of Trade—
- (a) that passenger steamers plying on any international voyage incur exceptional risks owing to weather and traffic conditions; and
 - (b) that owing to the small proportion of space allotted to cargo in any steamer constructed after the thirtieth day of June, nineteen hundred and thirty-one, or converted to passenger service after that date, the steamer can be sub-divided to a greater extent than is required by the Safety Convention;

the Board shall direct a ship surveyor to satisfy himself, before stating in a declaration of survey that the steamer is fit to ply on that voyage, that the steamer is subdivided to such greater extent as appears to the Board to be practicable and expedient in the interest of safety.

- (3) The survey regulations applicable to passenger steamers plying on international voyages shall include such requirements as appear to the Board of Trade to implement the provisions relating to surveys which are contained in Chapter II of the Safety Convention and the Regulations referred to therein (except in so far as the said provisions are otherwise implemented by the Merchant Shipping Acts).

2 Amendments as to declarations of survey.

- (1) A declaration of survey made by a ship surveyor in respect of a passenger steamer shall, instead of stating the particulars required by paragraph (d) of subsection (3) of section two hundred and seventy-two of the principal Act, state the voyages or class of voyages on which, as regards construction and equipment, the steamer is in the surveyor's judgment fit to ply.
- (2) A declaration of survey made by an engineer surveyor in respect of a passenger steamer shall, instead of stating the particulars required by paragraph (e) of subsection (4) of the said section, state the voyages or class of voyages on which, as regards machinery, the steamer is in the surveyor's judgment fit to ply.
- (3) If in the judgment of any such surveyor a passenger steamer is fit to ply on international voyages while engaged in a special passenger trade only, his declaration of survey shall state that fact.

3 Alteration of ships and additional surveys.

- (1) The owner or master of a passenger steamer to which this section applies shall, as soon as possible after any alteration is made in the steamer's hull, equipments or machinery which affects the efficiency thereof or the seaworthiness of the steamer, give written notice to the Board of Trade containing full particulars of the alteration, and, if notice is not so given, the owner or master of the steamer shall for each offence be liable to a fine not exceeding fifty pounds.
- (2) If the Board of Trade have reason to believe that since the making of the last declaration of survey in respect of a passenger steamer to which this section applies—
 - (a) any such alteration as aforesaid has been made in the hull, equipments or machinery of the steamer; or
 - (b) the hull, equipments or machinery of the steamer have sustained any injury or are otherwise insufficient;the Board may, without prejudice to their powers under section two hundred and seventy-nine of the principal Act, require the steamer to be again surveyed to such extent as they think fit, and, if such requirement is not complied with, may cancel any certificate issued in respect of the steamer under section two hundred and seventy-four of the principal Act or under this Part of this Act.
- (3) This section applies to every passenger steamer, whether British or foreign, in respect of which any such certificate as aforesaid is for the time being in force, and for the purpose of this section the expression "alteration" in relation to the hull, equipments or machinery of a steamer includes the renewal of any part thereof.

Life-Saving Appliances.

4 Rules for life-saving appliances to implement Chapter III of Safety Convention.

The rules for life-saving appliances applicable to passenger steamers plying on international voyages shall include such requirements as appear to the Board of Trade to implement the provisions of Chapter III of the Safety Convention and the Regulations referred to therein (except in so far as the said provisions are otherwise implemented by the Merchant Shipping Acts):

Provided that—

- (a) the Board may, on such conditions as they think fit, exempt any steamer constructed before the first day of July, nineteen hundred and thirty-one, from any such requirement, if and to the extent that they are satisfied that that requirement is either impracticable or unreasonable in the case of that steamer;
- (b) the Board may, as respects passenger steamers plying on any international coasting voyage, modify any such requirement, if and to the extent that they are satisfied that the risks incurred by steamers plying on that voyage are such as to make it unreasonable or unnecessary for such steamers to comply with that requirement;
- (c) the Board may, as respects passenger steamers engaged in any passenger trade in which they are employed in the carriage of large numbers of unberthed passengers, if they are satisfied that it is impracticable for steamers so engaged to comply with the said requirements, modify the said requirements in such manner as may appear to them to be necessary or expedient for the purpose of giving effect to the provisions of sub-paragraphs (a), (b) and (c) of paragraph 5 of Article twelve of the Safety Convention;
- (d) the Board may, as respects any passenger steamer plying on short international voyages, make such modifications of the said requirements as appear to them to be authorised by the provisions of the Safety Convention contained in sub-paragraph (b) of paragraph 2 of Article thirteen, paragraph (4) of Regulation XXXVI, paragraph (11) of Regulation XXXVII, paragraph (2) of Regulation XXXVIII, and Regulation XXXIX.

5 Amendments of Merchant Shipping Acts as to lifesaving appliances.

- (1) The power of the Board of Trade under section four hundred and twenty-seven of the principal Act to make rules for life-saving appliances shall include power to make rules with respect to all or any of the following matters, namely :—
 - (a) the marking of boats, lifeboats, life-rafts and buoyant apparatus so as to show the dimensions thereof and the number of persons authorised to be carried thereon;
 - (b) the manning of boats and lifeboats and the qualifications and certificates of lifeboat men;
 - (c) the provision to be made for mustering the passengers and crew and for embarking them in the boats and lifeboats (including provision as to the lighting of, and as to the means of ingress to, and egress from, different parts of the ship);
 - (d) the practising of boat drills;
 - (e) the assignment of specific duties to each member of the crew in the event of emergency;

Status: This is the original version (as it was originally enacted).

- (f) the methods to be adopted and the appliances to be carried for the prevention, detection and extinction of fire.
- (2) Subsection (1) of section four hundred and thirty of the principal Act (which imposes penalties for failure to comply with the rules for life-saving appliances) shall be amended by inserting after paragraph (d) thereof the following paragraph:—
- “(e) if any provision of the rules for life-saving appliances applicable to the ship is contravened or not complied with.”
- (3) The following section shall be substituted for section four hundred and thirty-one of the principal Act:—
- (1) A surveyor of ships may inspect any ship for the purpose of seeing that the rules for life-saving appliances have been complied with in her case, and for the purpose of any such inspection shall have all the powers of a Board of Trade Inspector under this Act.
- (2) If the surveyor finds that the rules for life-saving appliances have not been complied with, he shall give written notice to the owner or master stating in what respect the said rules have not been complied with, and what, in his opinion, is required to rectify the matter.
- (3) Every notice so given shall be communicated in manner directed by the Board of Trade to the Chief Officer of Customs of any port at which the ship may seek to obtain a clearance or transire, and a clearance or transire shall not be granted to the ship and the ship shall be detained until a certificate under the hand of a surveyor of ships is produced to the effect that the matter has been rectified.”
- (4) Subsection (4) of section two hundred and seventy-two of the principal Act (which relates to the statements to be made in the declaration of survey made by an engineer surveyor) shall be amended by substituting in paragraph (c) thereof the words "appliances for the prevention, detection and extinction of fire" for the words "fire hose", and subsection (2) of section two hundred and eighty-five of the principal Act shall cease to have effect.
- (5) Subsection (1) of section nine of the Merchant Shipping Act, 1906, (which requires the master of every British ship to enter in the official log book a statement of every occasion on which boat drill is practised on board the ship) shall be amended by inserting at the end thereof the words "and if, in the case of a passenger" steamer, boat drill is not practised on board the ship" in any week, the master shall enter a statement of "the reasons why boat drill was not practised in that" week."

Wireless Telegraphy.

6 Wireless telegraphy rules to implement Chapter IV of Safety Convention.

- (1) The wireless telegraphy rules applicable to ships plying on international voyages shall include such requirements as appear to the Board of Trade, after consultation with the Postmaster-General, to implement the provisions of Chapter IV of the Safety Convention (except in so far as the said provisions are otherwise implemented by the Merchant Shipping Acts).
- (2) The wireless telegraphy rules shall further require that the wireless telegraph installation to be provided on passenger steamers of five thousand tons gross

tonnage or upwards shall (after such date not being later than two years after the commencement of this Part of this Act as may be prescribed by the rules) include a wireless direction finding apparatus as required by Article forty-seven and paragraph 17 of Article thirty-one of the Safety Convention.

7 Amendments of 9 and 10 Geo. 5. c. 38.

- (1) The power of the Board of Trade, in consultation with the Postmaster-General, to make rules under subsection (2) of section one of the Merchant Shipping (Wireless Telegraphy) Act, 1919, shall include power to make rules—
 - (a) requiring the master of a ship to enter in the official log book such particulars relating to the operation of the wireless telegraph installation and as to the maintenance of the wireless telegraph service, as may be specified in the rules; and
 - (b) making provision as to the certificates to be held by, and the duties of, operators and watchers.
- (2) If the master of a British ship registered in the United Kingdom fails to comply with any such requirement, or if any operator or watcher on any such ship contravenes the said rules, he shall for each offence be liable to a fine not exceeding ten pounds.
- (3) The Board of Trade shall not, in pursuance of the powers conferred on them by the said Act, exempt from the obligations imposed by that Act any ship plying on international voyages, unless the exemption of the ship appears to the Board to be authorised by paragraph 2 of Article twenty-seven, or by Article twenty-eight, of the Safety Convention.
- (4) For the purposes of subsection (2) of section three of the said Act the expression "passengers" shall have the same meaning as it has for the purpose of Part III of the principal Act.

8 Appointment of wireless telegraphy surveyors.

A person appointed to be a surveyor of ships under section seven hundred and twenty-four of the principal Act may be appointed as a wireless telegraphy surveyor:

Provided that the functions of the Board of Trade under the said section with respect to surveyors of ships shall not be exercised with respect to wireless telegraphy surveyors except with the approval of the Postmaster-General.

9 Survey of passenger steamers by wireless telegraphy surveyors.

- (1) The surveys of a passenger steamer required by the principal Act shall, in the case of every survey made after the commencement of this Part of this Act in respect of a sea-going steamer which is not exempt under the Merchant Shipping (Wireless Telegraphy) Act, 1919, from the obligations imposed by that Act, include a survey by a wireless telegraphy surveyor, and accordingly subsection (1) of section two hundred and seventy-two of that Act shall be amended by inserting after the words "engineer surveyor of ships" the words "and, in the case of a sea-going passenger steamer required to be provided with a wireless telegraph installation, by a wireless telegraphy surveyor."
- (2) The following subsection shall be inserted at the end of the said section two hundred and seventy-two:—

“(5) The declaration of the wireless telegraphy surveyor shall contain statements of the following particulars, namely :—

- (a) the voyages or class of voyages on which, as regards wireless telegraphy, the steamer is fit to ply;
- (b) that, having regard to the tonnage of the steamer and the voyages or class of voyages on which she is declared to be fit to ply, the wireless telegraph installation complies with the wireless telegraphy rules;
- (c) that the certificates of the wireless telegraphy operators and watchers are such as are required by those rules.”

- (3) Section two hundred and seventy-five of the principal Act (which provides for appeals to a court of survey by persons aggrieved by the declaration of survey of a ship or engineer surveyor) shall be amended by inserting the words " or wireless telegraphy surveyor " after the words " engineer surveyor" in both places where they occur.

10 Survey of ships other than passenger steamers by wireless telegraphy surveyors.

The owner of every British ship of sixteen hundred tons gross tonnage or upwards registered in the United Kingdom, not being a passenger steamer or a ship exempt under the Merchant Shipping (Wireless Telegraphy) Act, 1919, from the obligations imposed by that Act, shall, before the ship first proceeds to sea on an international voyage from a port in the United Kingdom after the expiration of twelve months from the commencement of this Part of this Act and once in each year thereafter, cause the ship to be surveyed by a wireless telegraphy surveyor in the same manner as if she were a passenger steamer required to be provided with a wireless telegraph installation, and the provisions of sections two hundred and seventy-two, two hundred and seventy-three and two hundred and seventy-five of the principal Act shall apply accordingly.

Certificates.

11 Issue of safety certificates and passenger steamers' exemption certificates.

- (1) If the Board of Trade, on receipt of declarations of survey in respect of a passenger steamer, are satisfied that the steamer complies with all the construction regulations, rules for life-saving appliances and wireless telegraphy rules applicable to passenger steamers plying on international voyages, the Board shall, on the application of the owner of the steamer, issue in respect of the steamer a safety certificate stating that the steamer complies with the requirements of the Safety Convention, and any certificate issued under this subsection is hereafter in this Part of this Act referred to as " a general safety certificate."
- (2) If, on receipt of declarations of survey in respect of a passenger steamer in the case of which the Board of Trade have modified the construction regulations or the rules for life-saving appliances in pursuance of the foregoing provisions of this Act relating to steamers plying on short international voyages, the Board are satisfied that the steamer complies with the said regulations and rules as so modified, and also complies with the wireless telegraphy rules applicable to steamers plying on international voyages, the Board shall, on the application of the owner of the steamer, issue in respect of the steamer a safety certificate stating that the steamer complies with the requirements of the Safety Convention applicable to a short international voyage, and any certificate

issued under this subsection is hereafter in this Part of this Act referred to as " a short voyage safety certificate."

(3) If the Board of Trade, on receipt of declarations of survey in respect of a passenger steamer, are satisfied that the steamer—

- (a) complies with all the construction regulations and rules for life-saving appliances applicable to passenger steamers plying on international voyages or with those regulations and rules as modified in her case in pursuance of the foregoing provisions of this Act relating to steamers plying on short international voyages, and also is exempt under the Merchant Shipping (Wireless Telegraphy) Act, 1919, from the obligations imposed by that Act; or
- (b) complies with the construction regulations and the rules for life-saving appliances applicable to steamers plying on any international coasting voyage or steamers engaged in any special passenger trade, and also either complies with the wireless telegraphy rules applicable to steamers plying on international voyages or is exempt under the Merchant Shipping (Wireless Telegraphy) Act, 1919, from the obligations imposed by that Act;

the Board shall, on the application of the owner of the steamer, issue in respect of the steamer—

- (i) a safety certificate stating in what respects the steamer complies with the requirements of the Safety Convention; and
- (ii) an exemption certificate stating that so long as the steamer plies on the voyages, and is engaged in the trades, and complies with the conditions (if any) specified in the certificate, the steamer is exempt in other respects from the requirements of the said Convention;

and any safety certificate and exemption certificate issued under this subsection are hereafter in this Part of this Act respectively referred to as " a qualified safety certificate " and " a passenger steamer's exemption certificate. "

(4) For the purposes of this section, the Board of Trade may treat—

- (a) any passenger steamer constructed before the first day of July, nineteen hundred and thirty-one, (not being a steamer converted to passenger service on or after that date) as complying with the construction regulations applicable in the circumstances; and
- (b) any passenger steamer constructed before the first day of July, nineteen hundred and thirty-one, as complying with the rules for life-saving appliances applicable in the circumstances;

if they are satisfied that such steps (if any) as are reasonable and practicable have been taken to make the steamer comply with those regulations or rules, as the case may be.

(5) The provisions of this section shall, subject to the provisions hereafter contained in this Part of this Act, apply only to British passenger steamers registered in the United Kingdom.

12 Modification of safety certificates as respects life saving appliances.

(1) If, on any international voyage, a British passenger steamer registered in the United Kingdom in respect of which a safety certificate is in force has on board a total number of persons less than the number stated in that certificate to be the number for which the life-saving appliances on the steamer provide, the Board of Trade, or any person authorised by them for the purpose, may, at the request of the master of the steamer, issue a memorandum stating the total number of persons carried on the steamer on that

voyage, and the consequent modifications which may be made for the purpose of that voyage in the particulars with respect to life-saving appliances stated in the certificate, and that memorandum shall be annexed to the certificate.

- (2) Every such memorandum shall be returned to the Board of Trade at the end of the voyage to which it relates, and, if it is not so returned, the master of the steamer shall be liable to a fine not exceeding twenty pounds.

13 Issue of wireless telegraphy certificates and wireless telegraphy exemption certificates.

- (1) On receipt of a declaration of survey by a wireless telegraphy surveyor in respect of a British ship registered in the United Kingdom not being a passenger steamer, the Board of Trade shall, if satisfied that the ship complies with the wireless telegraphy rules applicable to ships (other than passenger steamers) plying on international voyages, issue a certificate stating that the ship complies with the requirements of the Safety Convention relating to wireless telegraphy, and any certificate issued under this subsection is hereafter in this Part of this Act referred to as "a wireless telegraphy certificate."
- (2) Where any such ship is exempted under the Merchant Shipping (Wireless Telegraphy) Act, 1919, from the obligations imposed by that Act, the Board of Trade, on the application of the owner of the ship, shall issue an exemption certificate stating that the ship is exempted from the requirements of the Safety Convention relating to wireless telegraphy and specifying the voyages on which, and conditions (if any) on which, the ship is so exempted, and any certificate issued under this subsection is hereafter in this Part of this Act referred to as "a wireless telegraphy exemption certificate."

14 Prohibition on proceeding to sea without certificate.

- (1) No ship to which this section applies shall proceed to sea on an international voyage from a port in the United Kingdom after the expiration of twelve months from the commencement of this Part of this Act, unless there is in force in respect of the ship—
- (a) in the case of a ship being a passenger steamer, either—
- (i) a general safety certificate; or
 - (ii) a short voyage safety certificate; or
 - (iii) a qualified safety certificate and passenger steamer's exemption certificate;
- being a certificate or certificates which by the terms thereof is or are applicable to the voyage on which the ship is about to proceed and to the trade in which she is for the time being engaged;
- (b) in the case of a ship not being a passenger steamer, either—
- (i) such certificate or certificates as would be required in her case by the foregoing provisions of this section if she were a passenger steamer; or
 - (ii) a wireless telegraphy certificate; or
 - (iii) a wireless telegraphy exemption certificate which by the terms thereof is applicable to the voyage on which the ship is about to proceed.
- (2) If any ship to which this section applies proceeds, or attempts to proceed, to sea in contravention of this section—

Status: This is the original version (as it was originally enacted).

- (a) in the case of a ship being a passenger steamer, the master or owner of the steamer shall, without prejudice to any other remedy or penalty under the Merchant Shipping Acts, be liable for each offence to a fine not exceeding ten pounds for every passenger carried on board the steamer, and the master or owner of any tender by means of which passengers are taken on board the steamer shall for each offence be liable to a like penalty for every passenger so taken on board; and
 - (b) in the case of a ship not being a passenger steamer, the master or owner of the ship shall for each offence be liable to a fine not exceeding one hundred pounds.
- (3) The master of every ship to which this section applies shall produce to the officer of customs from whom a clearance for the ship is demanded for an international voyage, the certificate or certificates required by the foregoing provisions of this section to be in force when the ship proceeds to sea, and a clearance shall not be granted, and the ship may be detained, until the said certificate or certificates are so produced.
- (4) Where a passenger steamer's exemption certificate or wireless telegraphy exemption certificate issued in respect of any ship to which this section applies specifies any conditions on which the certificate is issued and those conditions are contravened, the master or owner of the ship shall for each offence be liable to a fine not exceeding one hundred pounds.
- (5) This section applies to British ships registered in the United Kingdom, being passenger steamers or being ships of sixteen hundred tons gross tonnage or upwards.

15 Miscellaneous provisions as to certificates.

- (1) A safety certificate, wireless telegraphy certificate, or exemption certificate issued by the Board of Trade shall not be in force for more than one year from the date of its issue, nor after notice is given by the Board to the owner, agent, or master of the ship in respect of which it has been issued, that the Board have cancelled the certificate.
- (2) If a British ship registered in the United Kingdom, in respect of which any such certificate has been issued, is absent from the United Kingdom at the date when the certificate expires, the Board of Trade, or any person authorised by them for the purpose, may, if it appears proper and reasonable so to do, grant such an extension of the certificate as will allow the ship to return to the United Kingdom, but no such extension shall have effect for a period exceeding five months from the said date.
- (3) Every such certificate shall be in such form as may be prescribed by rules made by the Board of Trade, and those rules shall make such provision as appears to the Board to be necessary for the purpose of giving effect to the provisions of Article fifty-one of the Safety Convention, and may provide for combining a safety certificate in one document with a passenger steamer's certificate.
- (4) Any such certificate, and any passenger steamer's certificate combined in one document with a safety certificate, may be signed on behalf of the Board of Trade by any person authorised by the Board for the purpose, and a certificate purporting to be so signed shall be admissible in evidence in like manner as if it had been signed by one of the persons mentioned in section seven hundred and nineteen of the principal Act.
- (5) The following provisions of the principal Act shall apply to and in relation to every such certificate issued by the Board of Trade in the same manner as they apply to and in relation to a passenger steamer's certificate, namely, section two hundred and seventy-

six (which relates to the transmission of the certificate to the owner of the steamer), section two hundred and seventy-seven (which relates to the fees to be paid for the certificate), section two hundred and seventy-nine (which relates to the cancellation of the certificate), section two hundred and eighty (which relates to the delivery up of the certificate) and section two hundred and eighty-one (which relates to the posting up of the certificate on the ship).

- (6) The Board of Trade may request the Government of a country to which the Safety Convention applies to issue a general safety certificate, a short voyage safety certificate or a wireless telegraphy certificate in respect of a British ship registered in the United Kingdom, and a certificate issued in pursuance of such a request and containing a statement that it has been so issued shall have effect for the purposes of this Act as if it had been issued by the Board.

Provisions as to Safety Convention Ships not registered in the United Kingdom.

16 Certificates of Convention ships not registered in United Kingdom.

- (1) The Board of Trade may, at the request of the Government of a country to which the Safety Convention applies, issue a general safety certificate, a short voyage safety certificate or a wireless telegraphy certificate in respect of a ship of that country if they are satisfied in like manner as in the case of a British ship registered in the United Kingdom that they can properly issue the certificate, and, where a certificate is issued at such a request, it shall contain a statement that it has been so issued.
- (2) With a view to determining the validity in the United Kingdom of certificates purporting to have been issued in accordance with the Safety Convention in respect of Safety Convention ships not registered in the United Kingdom, the Board of Trade shall make such regulations as appear to the Board to be necessary for the purpose of giving effect to Article fifty-five of the Safety Convention, and, for the purpose of the provisions hereafter contained in this Part of this Act relating to Safety Convention ships not registered in the United Kingdom, the expression "a valid Safety Convention certificate" means a certificate or certificates complying with such of those regulations as are applicable in the circumstances.
- (3) Where a valid Safety Convention certificate is produced in respect of a Safety Convention passenger steamer, not registered in the United Kingdom, and there is attached to the certificate a memorandum which—
- (a) has been issued by or under the authority of the Government of the country to which the steamer belongs; and
 - (b) modifies for the purpose of any particular voyage, in view of the number of persons actually carried on that voyage, the particulars stated in the certificate with respect to life-saving appliances;

the certificate shall have effect for the purpose of that voyage as if it were modified in accordance with the memorandum.

17 Modifications as to survey of passenger steamers holding Convention certificate.

- (1) Where a valid Safety Convention certificate is produced in respect of a Safety Convention passenger steamer not registered in the United Kingdom—

Status: This is the original version (as it was originally enacted).

- (a) the provisions of the principal Act and of this Act as to the survey of passenger steamers by engineer and wireless telegraphy surveyors shall be deemed to have been complied with in the case of the steamer;
 - (b) the survey by the ship surveyor shall be limited to ascertaining the number of passengers which the steamer is fit to carry, and it shall not be necessary for the declaration of survey made by that surveyor to contain a statement of any further particulars than those set out in paragraph (e) of subsection (3) of section two hundred and seventy-two of the principal Act (which relates to the said number of passengers);
 - (c) on receipt of such a declaration, the Board of Trade shall issue a certificate under section two hundred and seventy-four of the principal Act containing only a statement of the particulars set out in paragraph (b) of that section (which relates to the said number of passengers), and a certificate so issued shall have effect as a passenger steamer's certificate.
- (2) Where there is produced in respect of any such passenger steamer a valid Safety Convention certificate, and also a certificate issued by or under the authority of the Government of the country to which the steamer belongs, showing the number of passengers which the steamer is fit to carry, and the Board of Trade are satisfied that that number has been determined substantially in the same manner as in the case of a British steamer registered in the United Kingdom, the Board may if they think fit dispense with the survey of the steamer mentioned in the last foregoing subsection and direct that the last mentioned certificate shall have effect as a passenger steamer's certificate.

18 Miscellaneous privileges of passenger steamers holding Convention certificate.

Where a valid Safety Convention certificate is produced in respect of a Safety Convention passenger steamer not registered in the United Kingdom—

- (a) the steamer shall be exempt from the following enactments, namely, paragraphs (d) and (f) of subsection (1) of section two hundred and ninety of the principal Act (which relate to the equipment of emigrant ships), and sections four hundred and twenty-seven to four hundred and thirty-one of that Act (which relate to life-saving appliances); and
- (b) the steamer shall not be deemed to be unsafe for the purposes of sections four hundred and fifty-nine or four hundred and sixty-two of the principal Act by reason of the defective condition of her hull, equipment or machinery, unless it appears that the steamer cannot proceed to sea without danger to the passengers or crew owing to the fact that the actual condition of the steamer does not correspond substantially with the particulars stated in the certificate.

19 Wireless telegraphy provisions applicable to ships holding Convention certificate.

- (1) Where a valid Safety Convention certificate is produced in respect of a Safety Convention ship not registered in the United Kingdom, being a passenger steamer or being a ship of sixteen hundred tons gross tonnage or upwards, then—
- (a) if the certificate shows that the ship is wholly exempt from the provisions of the Safety Convention relating to wireless telegraphy, the ship shall be exempt from the provisions of the Merchant Shipping (Wireless Telegraphy) Act, 1919;

- (b) if the certificate shows that the ship is not wholly exempt from the said provisions of the Safety Convention, the following provisions of this section shall apply to the ship in lieu of the provisions of the said Act.
- (2) A surveyor of ships may inspect the ship for the purpose of seeing that the wireless telegraph installation and the number of certified operators and watchers carried on the ship correspond substantially with the particulars stated in the certificate.
- (3) If it appears to the surveyor that the ship cannot proceed to sea without danger to the passengers or crew owing to the fact that the wireless telegraph installation or the number of operators or watchers does not correspond substantially with the said particulars, the surveyor shall give to the master notice in writing pointing out the deficiency and also pointing out what, in his opinion, is requisite to remedy the deficiency.
- (4) Every notice so given shall be communicated in manner directed by the Board of Trade to the chief officer of customs of any port at which the ship may seek to obtain a clearance or transire and to the consular officer for the country to which the ship belongs at or nearest to the port where the ship is for the time being, and a clearance or transire shall not be granted to the ship, and the ship shall be detained, until a certificate under the hand of a surveyor of ships is produced to the effect that the deficiency has been remedied.

20 Duty to produce Convention certificate.

The master of every Safety Convention ship not registered in the United Kingdom, being a passenger steamer or being a ship of sixteen hundred tons gross tonnage or upwards, shall produce a valid Safety Convention certificate to the officer of customs, from whom a clearance for the ship is demanded in respect of an international voyage from a port in the United Kingdom after the expiration of twelve months from the commencement of this Part of this Act, and a clearance shall not be granted, and the ship may be detained, until such a certificate is so produced.

21 Modification of existing provisions for exemption of ships not registered in United Kingdom.

- (1) The proviso to section four of the Merchant Shipping Act, 1906, (which provides for the exemption, in certain circumstances, of foreign ships from the provisions of the principal Act relating to life-saving appliances) and any Order in Council made thereunder shall, on the expiration of twelve months from the commencement of this Part of this Act, cease to apply to Safety Convention passenger steamers plying on international voyages.
- (2) The Merchant Shipping (Equivalent Provisions) Act, 1925, (which provides for the exemption, in certain circumstances, of foreign ships and British ships registered outside the United Kingdom from certain provisions of the Merchant Shipping Acts) and any Order in Council made thereunder shall, on the expiration of twelve months from the commencement of this Part of this Act, cease to apply to—
 - (a) Safety Convention ships, being passenger steamers plying on international voyages, in respect of the exemption of such ships from any provision of the Merchant Shipping Acts relating to the survey and certification of passenger steamers, to life-saving appliances or to wireless telegraphy ; and

Status: This is the original version (as it was originally enacted).

- (b) other Safety Convention ships so plying, in respect of the exemption of such ships from any provision of the Merchant Shipping Acts relating to wireless telegraphy.
- (3) Section two hundred and eighty-four of the principal Act (which provides for the recognition of colonial passenger steamers' certificates) and any Order in Council made thereunder, and section three hundred and sixty-three of that Act (which provides for the exemption of foreign passenger steamers from survey) shall, on the expiration of twelve months from the commencement of this Part of this Act, cease to apply to Safety Convention passenger steamers plying on international voyages.

Miscellaneous Provisions for furthering Safety of Life at Sea.

22 Duties as to watertight doors and other contrivances.

The rules set out in the Third Schedule to this Act with respect to watertight doors and other contrivances shall be complied with in every British passenger steamer registered in the United Kingdom, and if any of the said rules is contravened in the case of any such steamer, the master thereof shall for each offence be liable to a fine not exceeding one hundred pounds.

23 Submersion of subdivision load lines.

- (1) Where—
- (a) a British passenger steamer registered in the United Kingdom has been marked with subdivision load lines, that is to say, load lines indicating the depth to which the steamer may be loaded having regard to the extent to which she is subdivided and to the space for the time being allotted to passengers; and
 - (b) the appropriate subdivision load line, that is to say, the subdivision load line appropriate to the space for the time being allotted to passengers on the steamer, is lower than the load line indicating the maximum depth to which the steamer is for the time being entitled under Part II of this Act to be loaded;
- the steamer shall not be so loaded as to submerge the appropriate subdivision load line on each side of the steamer when the steamer has no list.
- (2) If any such steamer is loaded in contravention of this section, the owner or master of the steamer shall for each offence be liable to a fine not exceeding one hundred pounds and to such additional fine, not exceeding the amount hereinafter specified, as the court thinks fit to impose, having regard to the extent to which the earning capacity of the ship was, or would have been, increased by reason of the submersion.
- (3) The said additional fine shall not exceed one hundred pounds for every inch or fraction of an inch by which the appropriate subdivision load line on each side of the ship was submerged, or would have been submerged if the ship had had no list.
- (4) Without prejudice to any proceedings under the foregoing provisions of this section, any such steamer which is loaded in contravention of this section may be detained until she ceases to be so loaded.
- (5) The foregoing provisions of this section shall apply to passenger steamers not registered in the United Kingdom, while they are within any port in the United Kingdom, as they apply to British passenger steamers registered in the United Kingdom.

24 Report of dangers to navigation.

- (1) The master of any British ship registered in the United Kingdom, on meeting with dangerous ice, a dangerous derelict, a tropical storm or any other direct danger to navigation, shall send information accordingly, by all means of communication at his disposal and in accordance with rules to be made for the purposes of this section, to ships in the vicinity and to such authorities on shore as may be prescribed by those rules.
- (2) Rules for the purposes of this section shall be made by the Board of Trade and shall make such provision as appears to the Board to be necessary for the purpose of giving effect to the provisions of Article forty-four (so far as it relates to safety signals) and of Regulation XLVI of the Safety Convention.
- (3) If the master of a ship fails to comply with the provisions of this section, he shall for each offence be liable to a fine not exceeding fifty pounds.
- (4) Every person in charge of a wireless telegraph station which is under the control of the Postmaster General, or which is established or installed under licence of the Postmaster General, shall, on receiving the signal prescribed by the said rules for indicating that a message is about to be sent under this section, refrain from sending messages for a time sufficient to allow other stations to receive the message, and, if so required by the Board of Trade, shall transmit the message in such manner as may be required by the Board, and compliance with this subsection shall be deemed to be a condition of every licence granted by the Postmaster General under the Wireless Telegraphy Act, 1904:

Provided that nothing in this subsection shall interfere with the transmission by wireless telegraphy of any signal of distress or urgency prescribed under the next following section of this Act.
- (5) For the purposes of this section, the expression " tropical storm " means a hurricane, typhoon, cyclone, or other storm of a similar nature, and the master of a ship shall be deemed to have met with a tropical storm if he has reason to believe that there is such a storm in his vicinity.
- (6) The Derelict Vessels (Report) Act, 1896, shall cease to have effect.

25 Provisions as to signals.

- (1) His Majesty in Council may prescribe what signals shall be signals of distress and urgency, and the signals so prescribed shall be deemed to be signals of distress and urgency respectively.
- (2) Rules may be made by the Board of Trade prescribing the circumstances in and the purposes for which any signal prescribed by Order in Council under the last foregoing subsection is to be used, the circumstances in which it is to be revoked and the speed at which any message sent by wireless telegraphy in connection with the signal is to be transmitted, and those rules shall make such provision as appears to the Board to be necessary for the purpose of giving effect to Articles forty-two and forty-three of the Safety Convention and to Article forty-four thereof so far as it relates to signals of distress and urgency.
- (3) If the master of a ship uses or displays or causes or permits any person under his authority to use or display—

Status: This is the original version (as it was originally enacted).

- (a) any signal prescribed by Order in Council under this section except in the circumstances and for the purposes prescribed by the rules made under this section; or
- (b) any private signal, whether registered or not, which is liable to be mistaken for any signal so prescribed by Order in Council;

he shall for each offence be liable to a fine not exceeding fifty pounds and shall further be liable to pay compensation for any labour undertaken, risk incurred or loss sustained in consequence of the signal having been supposed to be a signal of distress or urgency, and that compensation may, without prejudice to any other remedy, be recovered in the same manner in which salvage is recoverable.

- (4) Section four hundred and thirty-four of the principal Act shall cease to have effect, but nothing in this Part of this Act shall affect any rules made under that section which are in force at the commencement of this Part of this Act, and any such rules shall, until revoked, have effect as if they had been made under the foregoing provisions of this section.
- (5) In addition to the private signals which the Board of Trade may refuse to register under section seven hundred and thirty-three of the principal Act, the Board may refuse to register any private signal which in their opinion cannot easily be distinguished from signals of urgency or signals prescribed for indicating that a message is about to be sent relating to a danger to navigation, and the Board may revoke the registration of any such signal registered under the said section of the principal Act, if in their opinion it cannot easily be so distinguished.

26 Obligation to render assistance on receiving wireless distress call.

- (1) The master of a British ship registered in the United Kingdom, on receiving on his ship a signal of distress by wireless telegraphy from any other ship, shall proceed with all speed to the assistance of the persons in distress, unless he is unable, or in the special circumstances of the case considers it unreasonable or unnecessary, to do so, or unless he is released under the provisions of subsection (3) or subsection (4) of this section.
- (2) The master of any ship in distress may, after consultation so far as possible with the masters of the ships which answer his signal of distress, requisition such one or more of those ships as he considers best able to render assistance, and it shall be the duty of the master of any British ship registered in the United Kingdom, which is so requisitioned, to comply with the requisition by continuing to proceed with all speed to the assistance of the persons in distress.
- (3) A master shall be released from the obligation imposed by subsection (1) of this section as soon as he is informed by the master of the ship requisitioned, or where more ships than one are requisitioned, all the masters of the ships requisitioned, that he or they are complying with the requisition.
- (4) A master shall be released from the obligation imposed by subsection (1) of this section and, if his ship has been requisitioned, from the obligation imposed by subsection (2) of this section, if he receives information that assistance is no longer required.
- (5) If the master of a British ship registered in the United Kingdom fails to comply with the foregoing provisions of this section, he shall be guilty of a misdemeanour.
- (6) If the master of a British ship registered in the United Kingdom, on receiving on his ship a signal of distress by wireless telegraphy from another ship, is unable or, in the

special circumstances of the case, considers it unreasonable or unnecessary, to go to the assistance of the persons in distress, he shall forthwith send a message by wireless telegraphy informing the master of that other ship accordingly, and enter in the official log-book his reasons for not going to the assistance of those persons, and if he fails to do so he shall be liable to a fine not exceeding one hundred pounds.

- (7) Nothing in this section shall affect the provisions of section six of the Maritime Conventions Act, 1911, and compliance by the master of a ship with the provisions of this section shall not affect his right, or the right of any other person, to salvage.

27 Signalling lamps.

No British ship registered in the United Kingdom, being a ship of over one hundred and fifty tons gross tonnage, shall proceed to sea on an international voyage, unless the ship is provided with a signalling lamp of a type approved by the Board of Trade, and if any ship proceeds or attempts to proceed to sea in contravention of this section, the owner or master thereof shall for each offence be liable to a fine not exceeding twenty pounds.

28 Carriage of dangerous goods.

- (1) The Board of Trade shall make such rules with respect to the carriage of goods on passenger steamers plying on international voyages, as appear to them to be necessary for the purpose of giving effect to the provisions of paragraph 1 of Article twenty-four of the Safety Convention.
- (2) If any of the rules made in pursuance of this section is contravened in the case of any British passenger steamer registered in the United Kingdom, the master or owner of the steamer shall for each offence be liable to a fine not exceeding three hundred pounds, and the steamer shall be deemed for the purposes of section four hundred and fifty-nine of the principal Act to be unsafe by reason of improper loading.
- (3) Any goods declared to be dangerous in their nature by the rules made under this section shall be deemed to be dangerous goods for the purpose of Part V of the principal Act.
- (4) The provisions of this section shall be deemed to be in addition to, and not in substitution for, or in restraint of, any other enactment for the like object, so however that nothing in this section shall be deemed to authorise any person to be sued or prosecuted twice in the same matter.
- (5) The foregoing provisions of this section and the rules made thereunder shall apply to passenger steamers not registered in the United Kingdom, while they are within any port in the United Kingdom, as they apply to British passenger steamers registered in the United Kingdom.

29 Method of giving helm orders.

- (1) No person on any British ship registered in the United Kingdom shall when the ship is going ahead give a helm or steering order containing the word "starboard" or "right" or any equivalent of "starboard" or "right", unless he intends that the head of the ship shall move to the right, or give a helm or steering order containing the word "port" or "left", or any equivalent of "port" or "left", unless he intends that the head of the ship shall move to the left.

- (2) Any person who contravenes the provisions of this section shall for each offence be liable to a fine not exceeding fifty pounds.

30 Careful navigation near ice.

- (1) The master of a British ship registered in the United Kingdom, when ice is reported on or near his course, shall at night either proceed at a moderate speed or change his course so as to keep amply clear of the ice reported and of the area of danger.
- (2) If the master of any such ship fails to comply with this section, he shall for each offence be liable to a fine not exceeding one hundred pounds.

31 Notice of Atlantic routes.

- (1) The owner of any line of passenger steamers crossing the North Atlantic from or to any port in the United Kingdom by regular routes shall give public notice, in such manner as may be directed by the Board of Trade, of the routes which it is proposed that the ships belonging to the line should follow, and of any changes which may be made in those routes.
- (2) If the owner of any such line of passenger steamers fails to comply with this section, he shall for each offence be liable to a fine not exceeding twenty pounds.

32 Contribution towards a service for watching ice and derelicts in the North Atlantic.

Any sums required for the contribution from the United Kingdom towards maintaining, in accordance with Articles thirty-six and thirty-seven of the Safety Convention, a service in the North Atlantic for the destruction or removal of derelicts, for the study and observation of ice conditions, and for ice patrol, shall be paid by the Board of Trade out of moneys provided by Parliament.

Supplemental.

33 Amendment of s. 267 of principal Act.

For the purposes of Part III of the principal Act, the expression " passenger" shall not include any person who is on board a ship either in pursuance of the obligation laid upon the master to carry shipwrecked, distressed or other persons or by reason of any circumstance which neither the master nor the owner nor the charterer (if any) of the ship could have prevented or forestalled, and accordingly section two hundred and sixty-seven of the principal Act shall be amended by inserting after the words " family and servants " the words " and persons on board the ship either in pursuance of the obligation laid upon the master to carry " shipwrecked, distressed or other persons or by reason " of any circumstance which neither the master nor the " owner nor the charterer (if any) could have prevented " or forestalled."

34 Power to amend rules and regulations to correspond with amendments of Safety Convention.

Where the Board of Trade are required by this Part of this Act to give effect to, or implement, any provision of the Safety Convention by any rules or regulations, and that provision is amended in pursuance of Article sixty-one of that Convention, the Board may amend the rules or regulations accordingly.

35 Certain rules and regulations to be laid before Parliament.

- (1) Where any of the construction regulations, survey regulations or rules for life-saving appliances applicable to passenger steamers plying on international voyages, or any of the wireless telegraphy rules applicable to ships plying on international voyages, being a regulation or rule made after the passing of this Act and in force at the commencement of this Part of this Act, contains, in the opinion of the Board of Trade, a requirement which—
 - (a) is at variance with any specific requirement of the Safety Convention; and
 - (b) was not contained in the regulations or rules in force at the passing of this Act;the regulation or rule, as the case may be, shall be laid before each House of Parliament as soon as may be after the commencement of this Part of this Act.
- (2) Where any of the construction regulations, survey regulations or wireless telegraphy rules, being a regulation or rule applicable as aforesaid and made after the commencement of this Part of this Act, contains, in the opinion of the Board of Trade, such a requirement as aforesaid, it shall be laid before each House of Parliament as soon as may be after it is made.
- (3) All rules for life-saving appliances made after the commencement of this Part of this Act shall be laid before each House of Parliament as soon as may be after they are made, together with a report stating whether any, and if so which, of the rules applicable to passenger steamers plying on international voyages contains, in the opinion of the Board of Trade, such a requirement as aforesaid, and all rules for life-saving appliances made before the commencement of this Part of this Act, which have not come into force before the commencement of this Part of this Act, shall be laid before each House of Parliament as soon as may be after the commencement of this Part of this Act, together with such a report as aforesaid.
- (4) If either House within the next subsequent twenty days on which that House has sat after—
 - (a) any regulation or rule is laid before it in pursuance of subsection (1) or subsection (2) of this section; or
 - (b) any rule is laid before it which is reported in pursuance of subsection (3) of this section to contain such a requirement as aforesaid;resolves that the regulation or rule shall be annulled, the regulation or rule shall thenceforth be void, but without prejudice to anything previously done thereunder or to the making of a new regulation or rule.
- (5) Subsection (2) of section four hundred and twenty-seven of the principal Act shall cease to have effect.

36 Application of Part I to British possessions, protectorates and mandated territories.

- (1) His Majesty may by Order in Council direct that the provisions of this Part of this Act and (so far as may appear to His Majesty to be expedient for the purpose of giving effect to the provisions of this Part of this Act) the provisions of any other Act relating to Merchant Shipping, including any enactments for the time being in force amending or substituted for the provisions of this Part of this Act or any other such Act, shall extend, with such exceptions, adaptations or modifications (if any) as may be specified in the Order, to the Isle of Man, any of the Channel Islands and any colony.
- (2) The Foreign Jurisdiction Act, 1890, shall have effect as if the provisions of this Part of this Act were included among the enactments which, by virtue of section five of that Act, may be extended by Order in Council to foreign countries in which for the time being His Majesty has jurisdiction.
- (3) His Majesty may by Order in Council direct—
 - (a) that any provision of this Part of this Act, which is expressed to apply only to British ships or passenger steamers registered in the United Kingdom, shall apply to British ships or passenger steamers, as the case may be, registered in any country or part of His Majesty's dominions to which the provisions of this Part of this Act can be extended by virtue of the foregoing provisions of this section;
 - (b) that any reference in this Part of this Act to a port in the United Kingdom shall be construed as including a reference to a port in any such country or part of His Majesty's dominions as aforesaid.

37 Countries to which Safety Convention applies.

His Majesty, if satisfied—

- (a) that the Government of any country has ratified, acceded to, or denounced, the Safety Convention; or
- (b) that the Safety Convention has been applied or has ceased to apply to any country in pursuance of the provisions of Article sixty-two thereof;

may by Order in Council make a declaration to that effect.

38 Interpretation of Part I.

In this Part of this Act the following expressions have the meanings hereby respectively assigned to them, that is to say:—

" Construction regulations " means such of the regulations made under section seven hundred and twenty-four of the principal Act as prescribe the matters with respect to which a surveyor of ships must be satisfied before he states in a declaration of survey that a passenger steamer is fit to ply on any particular voyages or class of voyages specified in the regulations;

" Country to which the Safety Convention applies " means—

- (a) a country the Government of which has been declared under the last foregoing section to have ratified, or acceded to, the Safety Convention, and has not been so declared to have denounced that Convention;
- (b) a country to which it has been so declared that the Safety Convention has been applied under the provisions of Article sixty-two thereof, not being

Status: This is the original version (as it was originally enacted).

a country to which it has been so declared that that Convention has ceased to apply under the provisions of that Article;

" Declaration of survey " means a declaration made under section two hundred and seventy-two of the principal Act;

" International voyage " means a voyage from a port in one country to a port in another country, either of those countries being a country to which the Safety Convention applies, " short international voyage " means an international voyage in the course of which a ship does not go more than two hundred miles from land, and " international coasting voyage " means an international voyage in the course of which a ship does not go more than twenty miles from land, so however that for the purpose of this provision—

(a) no account shall be taken of any deviation by a ship from her intended voyage due solely to stress of weather or any other circumstance which neither the master nor the owner nor the charterer (if any) of the ship could have prevented or forestalled; and

(b) every colony, overseas territory, protectorate or territory under suzerainty, and every territory in respect of which a mandate has been accepted on behalf of the League of Nations, shall be deemed to be a separate country;

" Rules for life-saving appliances " means the rules made under section four hundred and twenty-seven of the principal Act;

" Safety Convention ship " means a ship belonging to a country to which the Safety Convention applies, and the expression "Safety Convention passenger steamer" shall be construed accordingly;

" Special passenger trade " means a trade in relation to which the Board of Trade have modified the construction regulations or the rules for life-saving appliances in pursuance of this Part of this Act;

" Survey regulations " means such of the regulations made under section seven hundred and twenty-four of the principal Act as prescribe the manner in which surveys of passenger steamers are to be made;

" Wireless telegraphy rules " means the rules made under subsection (2) of section one of the Merchant Shipping (Wireless Telegraphy) Act, 1919.

39 Commencement of Part I and repeal.

- (1) This Part of this Act shall come into operation on such date as His Majesty in Council may appoint.
- (2) The enactments set out in Part I of the Fourth Schedule to this Act shall be repealed, to the extent specified in the third column of that Part of that Schedule, as from the commencement of this Part of this Act.

PART II

LOAD LINE AND LOADING.

Preliminary.

40 Ships exempt from Part II.

- (1) The following ships are exempt from this Part of this Act, namely—

Status: This is the original version (as it was originally enacted).

- (a) sailing ships under eighty tons register engaged solely in the coasting trade;
 - (b) ships exempted from this Part of this Act under subsection (2) of this section;
 - (c) ships solely engaged in fishing;
 - (d) pleasure yachts.
- (2) The Board of Trade may, on such conditions as they think fit, exempt from this Part of this Act—
- (a) any ship plying on international voyages between the near neighbouring ports of two or more countries, if the Board of Trade and the Governments of those countries are satisfied that the sheltered nature and conditions of the voyages between those ports make it unreasonable or impracticable to apply the provisions of this Part of this Act to ships so plying;
 - (b) any ship plying on any other voyage between near neighbouring ports if the Board of Trade are satisfied as aforesaid; and
 - (c) any class of steamers under eighty tons register engaged solely in the coasting trade, so long as they do not carry cargo.

41 Classification of ships for purpose of Part II.

- (1) Ships which are not exempt from this Part of this Act by virtue of the last foregoing section are hereafter in this Act referred to as "load line ships," and for the purposes of this Part of this Act are divided into the following classes, namely—
- (a) international load line ships, that is to say, ships of one hundred and fifty tons gross tonnage or upwards which carry cargo or passengers; and
 - (b) local load line ships, that is to say, ships of one hundred and fifty tons gross tonnage or upwards which do not carry cargo or passengers, and ships of less than that tonnage.
- (2) International load line ships belonging to countries to which the Load Line Convention applies, are hereafter in this Act referred to as "Load Line Convention ships."

Marking and Submersion of Load Lines.

42 Load line rules.

- (1) The Board of Trade shall make such rules (hereafter in this Act referred to as "the load line rules") as appear to them to be necessary for the purpose of giving effect to the provisions of Articles 6 to 10 of the Load Line Convention and Annex I and Annex II thereto.
- (2) Such of the load line rules as are made to give effect to Part II of Annex I to the said Convention are hereafter in this Act referred to as "the conditions of assignment."

43 Marking of deck-line and load lines.

- (1) No British load line ship registered in the United Kingdom, being a ship constructed after the thirtieth day of June, nineteen hundred and thirty-two, shall proceed to sea unless—
- (a) the ship has been surveyed in accordance with the load line rules; and
 - (b) the ship complies with the conditions of assignment ; and

Status: This is the original version (as it was originally enacted).

- (c) the ship is marked on each side with a mark (hereafter in this Act referred to as a "deck-line ") indicating the position of the uppermost complete deck as defined by the load line rules, and with marks (hereafter in this Act referred to as "load lines ") indicating the several maximum depths to which the ship can be safely loaded in various circumstances prescribed by the load line rules; and
 - (d) the deck-line and load lines are of the description required by the load line rules, the deck-line is in the position required by those rules, and the load lines are of the number required by such of those rules as are applicable to the ship; and
 - (e) the load lines are in the position required by such of the load line rules as are applicable to the ship.
- (2) No British load line ship registered in the United Kingdom, being a ship constructed before the first day of July, nineteen hundred and thirty-two, shall proceed to sea unless—
- (a) the ship has been surveyed and marked in accordance with paragraphs (a), (c) and (d) of the last foregoing subsection; and
 - (b) the ship complies with the conditions of assignment in principle and also in detail, so far as, in the opinion of the Board of Trade, is reasonable and practicable having regard to the efficiency of the protection of openings, the guard rails, the freeing ports and the means of access to the crew's quarters provided by the arrangements, fittings and appliances existing on the ship at the time when she is first surveyed under this section; and
 - (c) the load lines are either in the position required by paragraph (e) of the last foregoing sub-section or in the position required by the tables used by the Board of Trade on the thirty-first day of December, nineteen hundred and six, for fixing the position of load lines, subject to such modifications of those tables and of the application thereof, approved by the Board of Trade under section four hundred and thirty-eight of the principal Act, as were in force immediately before the fifth day of July, nineteen hundred and thirty.
- (3) If any ship proceeds or attempts to proceed to sea in contravention of this section, the master or owner thereof shall for each offence be liable to a fine not exceeding one hundred pounds.
- (4) Any ship attempting to proceed to sea without being surveyed and marked as required by this section may be detained until she has been so surveyed and marked, and any ship which does not comply with the conditions of assignment to the extent required in her case by this section shall be deemed to be unsafe for the purpose of section four hundred and fifty-nine of the principal Act.

44 Submersion of load line.

- (1) A British load line ship registered in the United Kingdom shall not be so loaded as to submerge in salt water, when the ship has no list, the appropriate load line on each side of the ship, that is to say, the load line indicating or purporting to indicate the maximum depth to which the ship is for the time being entitled under the load line rules to be loaded,
- (2) If any such ship is loaded in contravention of this section, the owner or master of the ship shall for each offence be liable to a fine not exceeding one hundred pounds and to such additional fine, not exceeding the amount hereinafter specified, as the court

Status: This is the original version (as it was originally enacted).

thinks fit to impose having regard to the extent to which the earning capacity of the ship was, or would have been, increased by reason of the submersion.

- (3) The said additional fine shall not exceed one hundred pounds for every inch or fraction of an inch by which the appropriate load line on each side of the ship was submerged, or would have been submerged if the ship had been in salt water and had had no list.
- (4) In any proceedings against an owner or master in respect of a contravention of this section, it shall be a good defence to prove that the contravention was due solely to deviation or delay, being deviation or delay caused solely by stress of weather or other circumstances which neither the master nor the owner nor the charterer (if any) could have prevented or forestalled.
- (5) Without prejudice to any proceedings under the foregoing provisions of this section, any ship which is loaded in contravention of this section may be detained until she ceases to be so loaded.

45 Miscellaneous offences in relation to marks.

If—

- (a) the owner or master of a British load line ship registered in the United Kingdom, which has been marked in accordance with the foregoing provisions of this Part of this Act, fails without reasonable cause to keep the ship so marked; or
- (b) any person conceals, removes, alters, defaces or obliterates, or suffers any person under his control to conceal, remove, alter, deface or obliterate any mark placed on any such ship in accordance with the foregoing provisions of this Part of this Act, except with the authority of a person entitled under the load line rules to authorise the alteration of the mark or except for the purpose of escaping capture by an enemy;

he shall for each offence be liable to a fine not exceeding one hundred pounds.

46 Inspection of ships with respect to load line.

A ship surveyor or engineer surveyor may inspect any British load line ship registered in the United Kingdom for the purpose of seeing that the provisions of this Part of this Act have been complied with in the case of the ship, and for the purpose of any such inspection any such surveyor shall have all the powers of a Board of Trade inspector under the principal Act.

Certificates.

47 Issue of load line certificates and effect thereof.

- (1) Where a British load line ship registered in the United Kingdom has been surveyed and marked in accordance with the foregoing provisions of this Part of this Act and complies with the conditions of assignment to the extent required in her case by those provisions, there shall be issued to the owner of the ship on his application and on payment of the prescribed fee—
 - (a) in the case of an international load line ship, a load line certificate hereafter in this Act referred to as "a Load Line Convention certificate"; and

Status: This is the original version (as it was originally enacted).

- (b) in the case of a local load line ship, a load line certificate hereafter in this Act referred to as " a United Kingdom load line certificate. "
- (2) Every such certificate shall be issued either by the Board of Trade or by such other person as may be authorised in that behalf by the Board, and shall be issued in such form and manner as may be prescribed by the load line rules, and those rules shall make such provision with respect to Load Line Convention certificates as appears to the Board to be necessary, having regard to the provisions of Rules IV and LXVUI of the Load Line Convention, for the purpose of giving effect to the provisions of Article thirteen of that Convention.
- (3) Any such certificate issued by the Board of Trade may be signed on behalf of the Board by any person authorised by the Board for the purpose, and a certificate purporting to be so signed shall be admissible in evidence in like manner as if it had been signed by one of the persons mentioned in section seven hundred and nineteen of the principal Act.
- (4) The Board of Trade may request the Government of a country to which the Load Line Convention applies to issue a Load Line Convention certificate in respect of a Load Line Convention ship registered in the United Kingdom, and a certificate issued in pursuance of such a request and containing a statement that it has been so issued shall have effect for the purpose of this Part of this Act as if it had been issued by the Board.
- (5) Where a load line certificate, issued in pursuance of this section and for the time being in force, is produced in respect of a ship, the ship shall, for the purpose of the foregoing provisions of this Part of this Act, be deemed to have been surveyed as required by those provisions, and, if the deck-line and load lines on the ship are of the number and description required by the load line rules and the position of the deck-line and load lines corresponds with the position specified in the certificate, the ship shall be deemed to be marked as required by those provisions.

48 Duration, renewal and cancellation of certificates.

- (1) Every load line certificate issued by or under the authority of the Board of Trade shall, unless it is renewed in accordance with the provisions of subsection (2) of this section, expire at the end of such period, not exceeding five years from the date of its issue, as may be specified therein.
- (2) Any such load line certificate may, after a survey not less effective than the survey required by the load line rules before the issue of the certificate, be renewed from time to time by the Board of Trade, or by any person authorised by the Board to issue a load line certificate, for such period (not exceeding five years on any occasion) as the Board of Trade or other person renewing the certificate thinks fit.
- (3) The Board of Trade shall cancel any such load line certificate in force in respect of a ship, if they have reason to believe that—
- (a) material alterations have taken place in the hull or superstructures of the ship which affect the position of the load lines; or
 - (b) the fittings and appliances for the protection of openings, the guard rails, the freeing ports or the means of access to the crew's quarters have not been maintained on the ship in as effective a condition as they were in when the certificate was issued.

Status: This is the original version (as it was originally enacted).

- (4) The owner of every ship in respect of which any such certificate has been issued shall, so long as the certificate remains in force, cause the ship to be surveyed in the prescribed manner once at least in each year after the issue of the certificate for the purpose of seeing whether the certificate should remain in force, having regard to the last foregoing subsection, and if the ship is not so surveyed, the Board of Trade shall cancel the certificate:

Provided that the Board, if they think fit in any particular case, may extend the said period of one year.

- (5) Where any such load line certificate has expired or been cancelled, the Board of Trade may require the owner or master of the ship to which the certificate relates to deliver up the certificate as they direct, and the ship may be detained until such requirement has been complied with, and if the owner or master fails without reasonable cause to comply with such requirement, he shall for each offence be liable to a fine not exceeding ten pounds.
- (6) On the survey of any ship in pursuance of this section there shall be paid by the owner of the ship such fee as may be prescribed.

49 Ships not to proceed to sea without certificate.

- (1) No British ship registered in the United Kingdom, being an international load line ship, shall proceed to sea unless there is in force in respect of the ship a Load Line Convention certificate.
- (2) No British ship registered in the United Kingdom, being a local load line ship, shall proceed to sea unless there is in force in respect of the ship a United Kingdom load line certificate.
- (3) The master of every British load line ship registered in the United Kingdom shall produce to the officer of Customs, from whom a clearance or transire for the ship is demanded, the certificate which is required by the foregoing provisions of this section to be in force when the ship proceeds to sea, and a clearance or transire shall not be granted, and the ship may be detained, until that certificate is so produced.
- (4) The master of every ship which proceeds or attempts to proceed to sea in contravention of this section shall for each offence be liable to a fine not exceeding one hundred pounds.

50 Publication of load line certificate and particulars relating to depth of loading.

- (1) When a load line certificate has been issued in pursuance of the foregoing provisions of this Part of this Act in respect of a British load line ship registered in the United Kingdom—
- (a) the owner of the ship shall forthwith on the receipt of the certificate cause it to be framed and posted up in some conspicuous place on board the ship, and to be kept so framed and posted up and legible so long as the certificate remains in force and the ship is in use; and
 - (b) the master of the ship, before making any other entry in any official log-book, shall enter therein the particulars as to the position of the deck-line and load lines specified in the certificate.

- (2) Before any British load line ship registered in the United Kingdom leaves any dock, wharf, harbour or other place for the purpose of proceeding to sea, the master thereof shall—
- (a) enter in the official log-book such particulars relating to the depth to which the ship is for the time being loaded as the Board of Trade may by regulations prescribe; and
 - (b) cause a notice, in such form and containing such of the said particulars as may be required by the said regulations, to be posted up in some conspicuous place on board the ship and to be kept so posted up and legible until the ship arrives at some other dock, wharf, harbour or place:

Provided that the Board may by the said regulations exempt home trade ships or any class of home trade ships from the requirements of paragraph (b) of this subsection.

- (3) If the master or owner of any British load line ship registered in the United Kingdom fails to comply with the provisions of this section, he shall for each offence be liable to a fine not exceeding twenty pounds.

51 Insertion of particulars as to load line in agreements with crew.

- (1) Before an agreement with the crew of any British load line ship registered in the United Kingdom, in respect of which a load line certificate is in force, is signed by any member of the crew, the master of the ship shall insert in the agreement the particulars as to the position of the deck-line and load lines specified in the certificate, and if he fails to do so, he shall for each offence be liable to a fine not exceeding twenty pounds.
- (2) In the case of a British load line ship registered in the United Kingdom, being a foreign-going ship, a superintendent shall not proceed with the engagement of the crew until—
- (a) there is produced to him a load line certificate for the time being in force in respect of the ship; and
 - (b) he is satisfied that the particulars required by this section have been inserted in the agreement with the crew.

Special Provisions as to Load Line Convention Ships not registered in the United Kingdom.

52 Load line certificates of Convention ships not registered in United Kingdom.

- (1) The Board of Trade may, at the request of the Government of a country to which the Load Line Convention applies, issue a Load Line Convention certificate in respect of an international load line ship of that country if they are satisfied in like manner as in the case of a British ship registered in the United Kingdom that they can properly issue the certificate, and where a certificate is issued at such a request, it shall contain a statement that it has been so issued.
- (2) With a view to determining the validity in the United Kingdom of certificates purporting to have been issued in accordance with the Load Line Convention in respect of Load Line Convention ships not registered in the United Kingdom, the Board of Trade shall make such regulations as appear to the Board to be necessary for the purpose of giving effect to Article seventeen of the Load Line Convention, and, for the purpose of the provisions hereafter contained in this Part of this Act relating to Load Line Convention ships not registered in the United Kingdom, the expression " a

Status: This is the original version (as it was originally enacted).

valid Load Line Convention certificate " means a certificate complying with such of those regulations as are applicable in the circumstances.

53 Inspection and control of Convention ships not registered in United Kingdom.

- (1) A ship surveyor or engineer surveyor may go on board any Load Line Convention ship not registered in the United Kingdom, when within any port in the United Kingdom, for the purpose of demanding the production of any load line certificate for the time being in force in respect of the ship.
- (2) If a valid Load Line Convention certificate is produced to the surveyor on any such demand, the surveyor's powers of inspecting the ship with respect to load line shall be limited to seeing—
 - (a) that the ship is not loaded beyond the limits allowed by the certificate;
 - (b) that the position of the load lines on the ship corresponds with the position specified in the certificate;
 - (c) that no material alterations have taken place in the hull or superstructures of the ship which affect the position of the load lines;
 - (d) that the fittings and appliances for the protection of openings, the guard rails, the freeing ports and the means of access to the crew's quarters have been maintained on the ship in as effective a condition as they were in when the certificate was issued;

and for the purpose of any such inspection the surveyor shall have all the powers of a Board of Trade inspector under the principal Act.

- (3) If it is found on any such inspection that the ship is loaded beyond the limits allowed by the certificate, the ship may be detained and proceedings may be taken against the master or owner thereof under the provisions hereafter contained in this Part of this Act relating to the submersion of load lines on ships not registered in the United Kingdom.
- (4) If it is found on any such inspection that the load lines on the ship are not in the position specified in the certificate, the ship may be detained until the matter has been rectified to the satisfaction of the surveyor.
- (5) If it is found on any such inspection that the ship has been so materially altered in respect of the matters referred to in paragraphs (c) and (d) of subsection (2) of this section that the ship is manifestly unfit to proceed to sea without danger to human life, the ship shall be deemed to be unsafe for the purpose of section four hundred and fifty-nine of the principal Act (in the case of a British ship) or for the purpose of section four hundred and sixty-two of that Act (in the case of a foreign ship):

Provided that where the ship has been detained under either of the last-mentioned sections, the Board of Trade shall order the ship to be released as soon as they are satisfied that the ship is fit to proceed to sea without danger to human life.

- (6) If a valid Load Line Convention certificate is not produced to the surveyor on such demand as aforesaid, the surveyor shall have the same power of inspecting the ship, for the purpose of seeing that the provisions of this Part of this Act have been complied with, as if the ship were a British ship registered in the United Kingdom.
- (7) For the purposes of this section a ship shall be deemed, to be loaded, beyond the limits allowed by the certificate if she is so loaded as to submerge in salt water, when the ship has no list, the appropriate load line on each side of the ship, that is to say, the

load line appearing by the certificate to indicate the maximum depth to which the ship is for the time being entitled under the Load Line Convention to be loaded.

54 Certificates of Convention ships to be produced to Customs.

The master of every Load Line Convention ship not registered in the United Kingdom shall produce to the officer of Customs from whom a clearance or transire for the ship from any port in the United Kingdom is demanded—

- (a) in a case where clearance is demanded in respect of an international voyage, a valid Load Line Convention certificate;
- (b) in a case where clearance or transire is demanded in respect of any other voyage, either a valid Load Line Convention certificate or a United Kingdom load line certificate for the time being in force in respect of the ship;

and a clearance or transire shall not be granted, and the ship may be detained, until the certificate required by this section is so produced.

55 Modification of existing provisions for exemption of ships not registered in United Kingdom.

The Merchant Shipping (Equivalent Provisions) Act, 1925, (which provides for the exemption, in certain circumstances, of foreign ships and British ships registered outside the United Kingdom from certain provisions of the Merchant Shipping Acts) and any Order in Council made thereunder shall cease to apply to Load Line Convention ships plying on international voyages, in respect of the exemption of such ships from any of the provisions of this Part of this Act.

General Provisions as to Ships not registered in the United Kingdom.

56 Survey, marking and conditions of assignment in case of ships not registered in United Kingdom.

The provisions of section forty-three of this Act shall apply to load line ships not registered in the United Kingdom, proceeding or attempting to proceed to sea from ports in the United Kingdom, as they apply to British load line ships registered in the United Kingdom, subject to the following modification, namely:—

- (a) the said section shall not apply to a Load Line Convention ship not registered in the United Kingdom, if a valid Load Line Convention certificate is produced in respect of the ship; and
- (b) subject to the provisions of paragraph (a) of this section, a foreign ship which does not comply with the conditions of assignment to the extent required in her case by the said section forty-three shall be deemed to be unsafe for the purpose of section four hundred and sixty-two of the principal Act.

57 Submersion of load line on ships not registered in United Kingdom.

The provisions of section forty-four of this Act shall apply to load line ships not registered in the United Kingdom, while they are within any port in the United Kingdom, as they apply to British load line ships registered in the United Kingdom, subject to the following modifications, namely:—

- (a) no Load Line Convention ship shall be detained, and no proceedings shall be taken against the owner or master thereof, by virtue of the said section, except

Status: This is the original version (as it was originally enacted).

after an inspection by a ship surveyor or engineer surveyor as hereinbefore provided; and

- (b) the expression " the appropriate load line, " in relation to any ship not registered in the United Kingdom, shall mean—
- (i) in the case of a Load Line Convention ship in respect of which there is produced on such an inspection as aforesaid a valid Load Line Convention certificate, the load line appearing by the certificate to indicate the maximum depth to which the ship is for the time being entitled under the Load Line Convention to be loaded ;
 - (ii) in any other case, the load line which corresponds with the load line indicating the maximum depth to which the ship is for the time being entitled under the load line rules to be loaded or, if no load line on the ship corresponds as aforesaid, the lowest load line thereon.

58 Inspection of ships not registered in United Kingdom.

The provisions of section forty-six of this Act shall apply to load line ships, other than British ships registered in the United Kingdom or Load Line Convention ships not registered in the United Kingdom, while they are within any port in the United Kingdom, as they apply to British load line ships registered in the United Kingdom.

59 Load line certificates of ships not registered in United Kingdom.

- (1) The provisions of this Part of this Act relating to the issue, effect, duration, renewal and cancellation of United Kingdom load line certificates shall apply to load line ships not registered in the United Kingdom as they apply to British load line ships registered in the United Kingdom, subject to the following modifications, namely :—
- (a) any such certificate may be issued in respect of an international load line ship as in respect of a local load line ship, so however that any such certificate issued in respect of a Load Line Convention ship shall only be valid so long as the ship is not plying on international voyages, and shall be endorsed with a statement to that effect, and shall be cancelled by the Board if they have reason to believe that the ship is so plying; and
 - (b) the survey required for the purpose of seeing whether the certificate should remain in force shall take place when required by the Board of Trade.
- (2) Where the Board of Trade certify—
- (a) either—
 - (i) that by the law in force in any part of His Majesty's dominions outside the United Kingdom provision has been made for the fixing, marking and certifying of load lines on British ships (or any class or description of British ships) registered in that part of His Majesty's dominions; or
 - (ii) that provision has been made as aforesaid by the law in force in any foreign country with respect to ships (or any class or description of ships) of that country and has also been so made (or has been agreed to be so made) for recognising United Kingdom load line certificates as having the same effect in ports of that country as certificates issued under the said provision; and
 - (b) that the said provision for the fixing, marking and certifying of load lines is based on the same principles as the corresponding provisions of this Part of this Act and is equally effective;

His Majesty may by Order in Council direct that load line certificates issued in pursuance of the said provision in respect of British ships (or that class or description of British ships) registered in that part of His Majesty's dominions, or in respect of ships (or that class or description of ships) of that foreign country, as the case may be, shall have the same effect for the purpose of this Part of this Act as United Kingdom load line certificates:

Provided that no Order in Council made under this subsection shall apply to Load Line Convention ships plying on international voyages.

- (3) Sub-paragraph (i) of paragraph (a) of the last foregoing subsection shall apply with respect to any foreign country in which for the time being His Majesty has jurisdiction, as if that country was a part of His Majesty's dominions.

60 Certificates to be produced to Customs by ships not registered in United Kingdom.

The master of every load line ship, other than a British ship registered in the United Kingdom or a Load Line Convention ship not registered in the United Kingdom, shall produce to the officer of Customs, from whom a clearance or transire for the ship from any port in the United Kingdom is demanded, either a United Kingdom load line certificate or a certificate having effect under this Act as such a certificate, being a certificate for the time being in force in respect of the ship, and a clearance or transire shall not be granted, and the ship may be detained, until the certificate required by this section is so produced.

Loading of Timber.

61 Carriage of timber deck cargo.

- (1) The Board of Trade shall make regulations (hereafter in this section referred to as the "timber cargo regulations") as to the conditions on which timber may be carried as cargo in any uncovered space on the deck of any load line ship.
- (2) The timber cargo regulations shall contain such regulations as appear to the Board of Trade to be necessary for the purpose of giving effect to paragraph two of Article six of the Load Line Convention.
- (3) Subject to the provisions of the last foregoing subsection, the timber cargo regulations may prescribe generally the conditions on which timber may be carried as aforesaid in any load line ship either on all voyages or on any particular class of voyages and either at all seasons or at any particular season, and in particular may prescribe the manner and position in which the timber is to be stowed and the provision which is to be made on the ship for the safety of the crew.
- (4) If any provision of the timber cargo regulations is contravened in the case of any British load line ship registered in the United Kingdom, the master of the ship shall be liable to a fine not exceeding five hundred pounds:

Provided that in any proceedings against a master in respect of a contravention of the timber cargo regulations, it shall be a good defence to prove that the contravention was due solely to deviation or delay, being deviation or delay caused solely by stress

Status: This is the original version (as it was originally enacted).

of weather or other circumstances which neither the master nor the owner nor the charterer (if any) could have prevented or forestalled.

- (5) For securing the observance of the timber cargo regulations, any officer having authority in that behalf from the Board of Trade, either general or special, shall have power to inspect any load line ship carrying timber cargo in any uncovered space on her deck, and for that purpose shall have all the powers of a Board of Trade inspector under the principal Act.
- (6) The foregoing provisions of this section and the timber cargo regulations shall apply to load line ships not registered in the United Kingdom, while they are within any port in the United Kingdom, as they apply to British load line ships registered in the United Kingdom.

Supplemental.

62 Amendment of ss. 436 and 454 of the principal Act.

- (1) In subsections (1) and (3) of section four hundred and thirty-six and in subsection (1) of section four hundred and fifty-four of the principal Act the expression " freeboard " shall be substituted for the expression " clear side. "
- (2) Subsection (3) of the said section four hundred and thirty-six shall cease to have effect with respect to load line ships.
- (3) The following subsection shall be substituted for subsection (5) of the said section four hundred and thirty-six, namely—
 - “(5) In this section the expression ' freeboard ' means, in the case of any ship which is marked with a deck-line, the height from the water to the upper edge of the deck-line, and, in the case of any other ship, the height amidships from the water to the upper edge of the deck from which the depth of hold as stated in the register is measured.”

63 Power to amend rules to correspond with amendments of Load Line Convention.

If any provision of the Load Line Convention to which the Board of Trade are required by this Part of this Act to give effect by any rules or regulations is amended in pursuance of Article twenty of that Convention, the Board may amend the rules or regulations accordingly.

64 Application of Part II to British possessions, protectorates and mandatory territories.

- (1) His Majesty may by Order in Council direct that the provisions of this Part of this Act, including any enactments for the time being in force amending or substituted for the said provisions, shall extend, with such exceptions, adaptations or modifications (if any) as may be specified in the Order, to the Isle of Man, any of the Channel Islands and any colony.
- (2) The Foreign Jurisdiction Act, 1890, shall have effect as if the provisions of this Part of this Act were included among the enactments which, by virtue of section five of that Act, may be extended by Order in Council to foreign countries in which for the time being His Majesty has jurisdiction.

(3) His Majesty may by Order in Council direct—

- (a) that any provision of this Part of this Act which is expressed to apply only to British ships registered in the United Kingdom shall apply to British ships registered in any country or part of His Majesty's dominions to which the provisions of this Part of this Act can be extended by virtue of the foregoing provisions of this section;
- (b) that any reference in this Part of this Act to a port in the United Kingdom shall be construed as including a reference to a port in any such country or part of His Majesty's dominions as aforesaid.

65 Countries to which the Load Line Convention applies.

His Majesty, if satisfied—

- (a) that the Government of any country has ratified, acceded to, or denounced the Load Line Convention; or
- (b) that the Load Line Convention has been applied or has ceased to apply to any country in pursuance of the provisions of Article twenty-one thereof;

may by Order in Council make a declaration to that effect.

66 Interpretation of Part II.

In this Part of this Act the following expressions have the meanings hereby respectively assigned to them, that is to say :—

" Country to which the Load Line Convention applies, " means—

- (a) a country the Government of which has been declared under the last foregoing section to have ratified, or acceded to, the Load Line Convention, and has not been so declared to have denounced that Convention;
- (b) a country to which it has been so declared that the Load Line Convention has been applied under the provisions of Article twenty-one thereof, not being a country to which it has been so declared that that Convention has ceased to apply under the provisions of that Article;

" International voyage " means a voyage from a port in one country to a port in another country, either of those countries being a country to which the Load Line Convention applies, so however that for the purpose of this definition—

- (a) no account shall be taken of any deviation by a ship from her intended voyage due solely to stress of weather or any other circumstance which neither the master nor the owner nor the charterer (if any) of the ship could have prevented or forestalled; and
- (b) every colony, overseas territory, protectorate or territory under suzerainty, and every territory in respect of which a mandate has been accepted on behalf of the League of Nations, shall be deemed to be a separate country;

" Prescribed " means prescribed by the load line rules.

67 Commencement of Part II and repeal.

(1) Subject to the provisions of this subsection, this Part of this Act shall come into operation on the appointed day:

Provided that—

Status: This is the original version (as it was originally enacted).

- (a) where at the passing of this Act there is in force in respect of any ship a certificate issued under section four hundred and forty-three of the principal Act and that certificate ceases to be in force before the appointed day; or
- (b) where before the appointed day a load line certificate is issued in pursuance of this Part of this Act by or under the authority of the Board of Trade in respect of any ship;

this Part of this Act shall come into operation with respect to that ship as from the date on which the certificate ceases to be in force or is issued, as the case may be.

- (2) The enactments set out in Part II of the Fourth Schedule to this Act shall, to the extent specified in the third column of that Part of that Schedule, cease to have effect with respect to any ship as from the date when this Part of this Act comes into operation with respect to that ship and shall be repealed as from the appointed day:

Provided that any Order in Council in force immediately before the appointed day under section four hundred and forty-four or section four hundred and forty-five of the principal Act shall, until revoked, continue to have effect as if for references in the Order to Part V of the principal Act, or to the provisions of the principal Act relating to overloading or improper loading, as the case may be, there were substituted references to this Part of this Act, so however that no such Order shall continue to have effect with respect to Load Line Convention ships plying on international voyages.

- (3) For the purpose of this section the expression " the appointed day " means such day as His Majesty in Council may appoint.

PART III

GENERAL.

68 Provisions as to rules and regulations.

- (1) Notwithstanding any rules or regulations made in pursuance of this Act for the purpose of giving effect to, or implementing, any provision of the Safety Convention or Load Line Convention which requires a particular fitting, appliance, or apparatus or type thereof, to be fitted or carried in a ship, or any particular provision to be made in a ship, the Board of Trade may allow any other fitting, appliance or apparatus, or type thereof, to be fitted or carried, or any other provision to be made if they are satisfied that that other fitting, appliance or apparatus, or type thereof, or provision, is at least as effective as that required by the Convention.
- (2) Where under this Act the Board of Trade are required to make such regulations or rules as appear to them to be necessary for the purpose of giving effect to any of the provisions of the Safety Convention or Load Line Convention, the requirement shall, in the case of a provision the terms of which are such as to vest in the several Governments who are parties to the Convention a discretion as to whether any or what action should be taken thereunder, be construed as an authority to the Board to make by regulations or rules such provision (if any) with respect to the matter in question as the Board in the exercise of that discretion think proper.

69 Notice to be given to Consular officer where proceedings taken in respect of foreign ships.

Where any foreign ship is detained under this Act, and where any proceedings are taken under this Act against the master or owner of any such ship, notice shall forthwith be served on the Consular officer for the country to which the ship belongs at or nearest to the port where the ship is for the time being, and such notice shall specify the grounds on which the ship has been detained or the proceedings have been taken.

70 Cost of detaining ships.

Where a ship is detained in pursuance of any provision of this Act which provides for the detention of a ship until a certain event occurs, subsection (2) of section four hundred and sixty of the principal Act (which makes provision as to the costs of the Board of Trade of and incidental to the detention and survey of the ship) shall apply as if the ship had been finally detained within the meaning of that subsection.

71 Forgery of certificates.

The provisions of section two hundred and eighty-two of the principal Act (which imposes penalties for the forgery of passenger steamers' certificates) shall apply with respect to any certificate required for the purposes of this Act as they apply with respect to a passenger steamer's certificate.

72 Summary prosecution of offences.

Notwithstanding anything in section six hundred and eighty of the principal Act, any offence whatsoever under Part I or Part II of this Act may be prosecuted summarily.

73 Interpretation and construction.

(1) In this Act the following expressions have the meanings hereby respectively assigned to them, that is to say:—

" Contravention " includes, in relation to any provision, failure to comply with that provision, and the expression " contravenes " shall be construed accordingly;

" The Merchant Shipping Acts " means the Merchant Shipping Acts, 1894 to 1928, and this Act;

" Passenger " has the same meaning as it has for the purpose of Part III of the principal Act ;

" Passenger steamer " means a steamer carrying more than twelve passengers;

" The principal Act " means the Merchant Shipping Act, 1894.

(2) In this Act references to a ship constructed before or after any date shall be construed as references to a ship the keel of which has been laid before or after that date, as the case may be.

(3) For the purpose of any provision of this Act relating to Safety Convention ships, Safety Convention passenger steamers or Load Line Convention ships not registered in the United Kingdom, a passenger steamer or other ship registered in any of the Channel Islands or in the Isle of Man shall be deemed to be registered in the United Kingdom.

Status: This is the original version (as it was originally enacted).

- (4) Any references in this Act to any provision of the Merchant Shipping Acts, 1894 to 1928, which has been amended by any subsequent Act, including this Act, shall be construed as a reference to that provision as so amended.

74 Short title, citation and repeal.

- (1) This Act may be cited as the Merchant Shipping (Safety and Load Line Conventions) Act, 1932, and shall be construed as one with the Merchant Shipping Acts, 1894 to 1928, and those Acts and this Act may be cited together as the Merchant Shipping Acts, 1894 to 1932.
- (2) The enactments set out in Part III of the Fourth Schedule to this Act shall be repealed, to the extent specified in the third column of that Part of that Schedule, as from the passing of this Act.

SCHEDULES.

FIRST SCHEDULE

INTERNATIONAL CONVENTION FOR THE SAFETY OF LIFE AT SEA, 1929.

CHAPTER I

PRELIMINARY.

ARTICLE 1.

The Contracting Governments undertake to give effect to the provisions of the present Convention for the purpose of promoting safety of life at sea, to promulgate all regulations and to take all other steps which may be necessary to give the present Convention full and complete effect.

The provisions of the present Convention are completed by Regulations contained in Annex I, which have the same force and take effect at the same time as the present Convention. Every reference to the present Convention implies at the same time a reference to the Regulations annexed thereto.

ARTICLE 2

Applications and Definitions.

- 1 The provisions of the present Convention shall apply to ships belonging to countries the Governments of which are Contracting Governments, and to ships belonging to territories to which the present Convention is applied under Article 62, as follows :
—
Chapter II—(Construction) to passenger ships (mechanically propelled) on international voyages.
Chapter III—(Life-saving Appliances) to passenger ships (mechanically propelled) on international voyages.
Chapter IV—(Radiotelegraphy) to all ships engaged on international voyages except cargo ships of less than 1,600 tons gross tonnage.
Chapter V—(Safety of Navigation) to all ships on all voyages.
Chapter VI—(Certificates) to all the ships to which Chapters II, III and IV apply.
- 2 The classes of ships to which each Chapter applies are more precisely defined, and the extent of the application is shown in each Chapter.
- 3 In the present Convention, unless expressly provided otherwise—
 - (a) a ship is regarded as belonging to a country if it is registered at a port of that country;

Status: This is the original version (as it was originally enacted).

- (b) the expression " Administration " means the Government of the country in which the ship is registered;
 - (c) an international voyage is a voyage from a country to which the present Convention applies to a port outside such country, or conversely; and for this purpose every colony, overseas territory, protectorate or territory under suzerainty or mandate is regarded as a separate country;
 - (d) a ship is a passenger ship if it carries more than 12 passengers;
 - (e) the expression " Regulations " means the Regulations contained in Annex I.
- 4 The present Convention, unless expressly provided otherwise, does not apply to ships of war.

ARTICLE 3

Cases of Force Majeure.

No ship, which is not subject to the provisions of the present Convention at the time of its departure on any voyage, shall become subject to the provisions of the present Convention on account of any deviation from its intended voyage due to stress of weather or any other cause of force majeure.

Persons who are on board a ship by reason of force majeure or in consequence of the obligation laid upon the master to carry shipwrecked or other persons shall not be taken into account for the purpose of ascertaining the application to a ship of any provisions of the present Convention.

CHAPTER II

CONSTRUCTION.

ARTICLE 4.

Application.

- 1 This Chapter, except where it is otherwise expressly provided, applies to new passenger ships engaged on international voyages.
- 2 A new passenger ship is a ship the keel of which is laid on or after the 1st July, 1931, or a ship which is converted to passenger service on or after that date, all other passenger ships being described as existing passenger ships.
- 3 Each Administration may, if it considers that the route and the conditions of the voyage are such as to render the application of the requirements of this Chapter unreasonable or unnecessary, exempt from the requirements of this Chapter individual ships or classes of ships belonging to its country which, in the course of their voyage, do not proceed more than 20 miles from the nearest land.
- 4 In the case of a passenger ship which, in the course of its voyage, does not proceed more than 200 miles from the nearest land, the Administration of the country to which the ship belongs may allow relaxations from such of the requirements of Regulations IX, X, XV and XIX as may be proved to the satisfaction of the Administration to be neither reasonable nor practicable.
- 5 In the case of existing passenger ships engaged on international voyages which do not already comply with the provisions of this Chapter relating to new passenger ships, the arrangements on each ship shall be considered by the Administration of

Status: This is the original version (as it was originally enacted).

the country to which the ship belongs, with a view to improvements being made to provide increased safety where practicable and reasonable.

6 In the case of passenger ships engaged on international voyages which are employed in the carriage of large numbers of unborthed passengers in special trades, such, for example, as the pilgrim trade, an Administration, if satisfied that it is impracticable to enforce compliance with the requirements of this Chapter, may exempt such ships, when they belong to its country, from those requirements on the following conditions:—

(a) That the fullest provision which the circumstances of the trade will permit shall be made in the matter of construction:

(b) That steps shall be taken to formulate general rules which shall be applicable to the particular circumstances of these trades. Such rules shall be formulated in concert with such other Contracting Governments, if any, as may be directly interested in the carriage of such passengers.

7 This Chapter does not apply to ships which are not mechanically propelled or to wooden ships of primitive build, such as dhows, junks, &c.

ARTICLE 5

Watertight Subdivision of Ships.

1 Ships shall be as efficiently subdivided as is possible having regard to the nature of the service for which they are intended. The requirements respecting subdivision are given in the following Articles and in the Regulations.

2 The degree of subdivision provided for by these requirements varies with the length of the ship and with the service, in such manner that the highest degree of subdivision corresponds with the ships of greatest length primarily engaged in the carriage of passengers.

3 Regulations I to V indicate the method to be followed in order to determine the degree of subdivision applicable to a ship.

4 In order that the required degree of subdivision shall be maintained, a loadline corresponding to the approved subdivision draft shall be assigned and marked on the ship's sides. A ship having spaces which are specially adapted for the accommodation of passengers and the carriage of cargo alternatively may, if the owners desire, have one or more additional loadlines assigned and marked to correspond with the subdivision drafts which the Administration may approve for the alternative service conditions. The freeboard corresponding to each approved subdivision loadline, and the conditions of service for which it is approved, shall be clearly indicated on the Safety Certificate. Subdivision loadlines shall be marked and recorded in the manner provided in Regulation VII.

ARTICLE 6

Peak and Machinery Space Bulkheads, Shaft Tunnels, &c.

All ships shall be fitted with watertight forward and after peak bulkheads and with watertight bulkheads at the extremities of the machinery space, and, in screw ships, with watertight shaft tunnels or equivalent subdivision in accordance with the provisions of Regulation VI.

Status: This is the original version (as it was originally enacted).

ARTICLE 7

Construction, Testing, &c.

Regulations VHI to XIII and XV to XXI prescribe rules for—

- (a) the construction and testing of subdivision bulkheads, inner bottoms, watertight decks, trunks, ventilators, fire-resisting bulkheads, &c.;
- (b) the conditions governing openings in bulkheads, in the ship's sides and in the weather deck, and the character and use of means which shall be provided for closing these openings;
- (c) the tests and the periodical inspections and operation of the means of closing openings in bulkheads and in the ship's side;
- (d) exits from watertight compartments;
- (e) pumping arrangements; and
- (f) power for going astern and auxiliary steering apparatus.

ARTICLE 8

Stability Test.

Every new passenger ship shall be inclined upon its completion and the elements of its stability determined. The operating personnel shall be supplied with such information on this subject as is necessary to permit efficient handling of the ship.

ARTICLE 9

Entries in the Official Log Book.

A record of the closing and opening of watertight doors, &c, and of all inspections and drills, shall be entered in the official log book as required by Regulation XIV.

ARTICLE 10

Initial and Subsequent Surveys of Ships.

The general principles which shall govern the survey of ships, whether new or existing, as regards hull, main and auxiliary boilers and machinery, and equipments, are stated in Regulation XXII. Each Contracting Government undertakes—

- (1) to draw up detailed regulations in accordance with these general principles, or to bring its existing regulations into agreement with these principles;
- (2) to secure that these regulations shall be enforced.

The detailed regulations referred to in the preceding paragraph shall be in all respects such as to secure that, from the point of view of safety of life, the ship is fit for the service for which it is intended.

CHAPTER III

LIFE-SAVING APPLIANCES, &C.

ARTICLE 11.

Interpretation.

For the purposes of this Chapter—

- (a) the expression " new ship " means a ship the keel of which is laid on or after the 1st July, 1931, all other ships being described as existing ships;
- (b) the expression " short international voyage " means an international voyage in the course of which a ship is not more than 200 miles from the nearest land;
- (c) the expression " buoyant apparatus " means buoyant deck seats, or buoyant deck chairs, or any other buoyant apparatus, excepting boats, life-buoys and life-jackets.

ARTICLE 12

Application.

- 1 This Chapter, except where it is otherwise expressly provided, applies to new passenger ships which are mechanically propelled and engaged on international voyages.
- 2 Special provisions are laid down in Articles 13, 14, 19 and 25 with regard to new passenger ships engaged on short international voyages.
- 3 Each Administration, if it considers that the route and the conditions of the voyage are such as to render the application of the full requirements of this Chapter unreasonable or unnecessary, may to that extent exempt from the requirements of this Chapter individual ships or classes of ships belonging to its country which, in the course of their voyage, do not go more than 20 miles from the nearest land.
- 4 In the case of existing passenger ships which are mechanically propelled and engaged on international voyages and which do not already comply with the provisions of this Chapter relating to new passenger ships, the arrangements on each ship shall be considered by the Administration of the country to which the ship belongs, with a view to securing, so far as this is practicable and reasonable, compliance with the general principles set out in Article 13 not later than the 1st July, 1931, and substantial compliance with the other requirements of this Chapter.
- 5 In the case of passenger ships which are mechanically propelled and engaged on international voyages and which are employed in the carriage of large numbers of unberthed passengers in special trades, such, for example, as the pilgrim trade, an Administration, if satisfied that it is impracticable to enforce compliance with the requirements of this Chapter, may exempt such ships, when they belong to its country, from those requirements on the following conditions :—
 - (a) That the fullest provision which the circumstances of the trade will permit shall be made in the matter of lifeboats and other life-saving appliances and fire protection:
 - (b) That all such boats and apparatus shall be readily available within the meaning of Article 13 :
 - (c) That a life-jacket shall be provided for every person on board:

Status: This is the original version (as it was originally enacted).

- (d) That steps shall be taken to formulate general rules which shall be applicable to the particular circumstances of these trades. Such rules shall be formulated in concert with such other Contracting Governments, if any, as may be directly interested in the carriage of such passengers.

ARTICLE 13

Lifeboats and Buoyant Apparatus.

The general principles governing the provision of lifeboats and buoyant apparatus in a ship to which this Chapter applies are that they shall be readily available in case of emergency and shall be adequate.

- 1 To be readily available, the lifeboats and buoyant apparatus must comply with the following conditions :—
 - (a) They must be capable of being got into the water safely and rapidly even under unfavourable conditions of list and trim:
 - (b) It must be possible to embark the passengers in the boats rapidly and in good order;
 - (c) The arrangement of each boat and article of buoyant apparatus must be such that it will not interfere with the operation of other boats and buoyant apparatus.

- 2 To be adequate, the provision of lifeboats and buoyant apparatus must satisfy the following conditions:—
 - (a) Subject to the provisions of sub-paragraph (b) of this paragraph there must be accommodation in boats for all persons on board, and there must, in addition, be buoyant apparatus for 25 per cent. of the persons on board:
 - (b) In the case of passenger ships engaged on short international voyages, the boats must be provided in accordance with the requirements set out in the table in Regulation XXXIX, and there must be, in addition, buoyant apparatus so that the boats and buoyant apparatus together provide accommodation for all on board as set out in Regulation XXXVIII. There must, in addition, be buoyant apparatus for 10 per cent. of the persons on board :
 - (c) No more boats shall be required on any passenger ship than are sufficient to accommodate all persons on board.

ARTICLE 14

Ready Availability and Adequacy.

The arrangements for securing the principles of ready availability and adequacy mentioned in Article 13 shall be in accordance with the provisions of Regulations XXXVII, XXXVIII and XXXIX.

ARTICLE 15

Standard types of Boats. Life Rafts. Buoyant Apparatus.

All the lifeboats, life rafts and buoyant apparatus shall comply with the conditions fixed by this Convention and Regulations XXIV to XXIX.

Status: This is the original version (as it was originally enacted).

ARTICLE 16

Construction of Boats.

All boats must be properly constructed, and shall be of such form and proportions that they shall have ample stability in a seaway, and sufficient freeboard when loaded with their full complement of persons and equipment.

Each boat must be of sufficient strength to enable it to be safely lowered into the water when loaded with its full complement of persons and equipment.

ARTICLE 17

Embarkation of the Passengers in the Boats.

Suitable arrangements shall be made for embarking the passengers in the boats at an embarkation deck. There shall also be a suitable ladder provided at each set of davits.

ARTICLE 18

Capacity of Boats and Life Rafts.

The number of persons that a boat of one of the standard types or an approved life raft or buoyant apparatus can accommodate and the conditions of approval of life rafts and buoyant apparatus shall be ascertained in accordance with the provisions of Regulations XXX to XXXV inclusive.

ARTICLE 19

Equipment of Boats and Life Rafts.

Regulation XXXVI prescribes the equipment for boats and life rafts.

ARTICLE 20

Life-jackets and Life-buoys.

- 1 Every ship to which this Chapter applies shall carry for every person on board a life-jacket of a type approved by the Administration, and in addition, unless these life-jackets can be adapted for use by children, a sufficient number of life-jackets suitable for children.
- 2 Every such ship shall also carry life-buoys of a type approved as aforesaid to the number required by Regulation XL.
- 3 A life-jacket or life-buoy shall not be approved by an Administration unless it satisfies the requirements of Regulation XL applicable to life-jackets and life-buoys respectively.
- 4 In this Article the expression " life-jacket " includes any appliance capable of being fitted on the body, having the same buoyancy as a life-jacket.

ARTICLE 21

Means of Ingress and Egress. Emergency Lighting.

- 1 Proper arrangements shall be made for ingress to and egress from the different compartments, decks, &c.

Status: This is the original version (as it was originally enacted).

- 2 Provision shall be made for an electric or other system of lighting, sufficient for all requirements of safety, in the different parts of the ship, and particularly upon the decks on which the lifeboats are stowed. On ships in which the boat deck is more than 9.15 metres (30 feet) above the waterline at the lightest seagoing draught, provision shall be made for the illumination from the ship of the lifeboats when alongside and in process of or immediately after being launched. There must be a self-contained source capable of supplying, when necessary, this safety lighting system, and placed in the upper parts of the ship above the bulkhead deck.
- 3 The exit from every main compartment occupied by passengers or crew shall be continuously lighted by an emergency lamp. The power for these emergency lamps shall be so arranged that they will be supplied from the independent installation referred to in the preceding paragraph in the event of failure of the main generating plant.

ARTICLE 22

Certificated Lifeboatmen. Manning of the Boats.

- 1 In every ship to which this Chapter applies there must be, for any boat or life raft carried in order to comply with this Chapter, such number of certificated lifeboatmen as is required by Regulation XLI for that boat.
- 2 The allocation of the certificated lifeboatmen to each boat and life raft remains within the discretion of the master, according to the circumstances.
- 3 By " certificated lifeboatman " is meant any member of the crew who holds a certificate of efficiency issued under the authority of the Administration in accordance with the conditions laid down in the afore-mentioned Regulation.
- 4 The manning of the boats shall be as prescribed in Regulation XLII.

ARTICLE 23

Line-throwing Appliances.

Every ship to which this Chapter applies shall carry a line-throwing appliance of a type approved by the Administration.

ARTICLE 24

Dangerous Goods. Fire Protection.

- 1 The carriage, either as cargo or ballast, of goods which by reason of their nature, quantity, or mode of stowage, are, either singly, or collectively, liable to endanger the lives of the passengers or the safety of the ship, is forbidden.

This provision does not apply to the ship's distress signals, nor to the carriage of naval or military stores for the public service of the State under conditions authorised by the

Each Administration shall, from time to time by official notice, determine what goods are to be considered dangerous goods, and shall indicate the precautions which must be taken in the packing and stowage thereof.

- 2 The arrangements to be made for the detection and extinction of fire shall be as prescribed in Regulation XLIII.

ARTICLE 25

Muster Roll and Drills.

Special duties for the event of an emergency shall be allotted to each member of the crew.

The muster list shall show all these special duties and shall indicate, in particular, the station to which each man must go, and the duties that he has to perform.

Before the vessel sails, the muster list shall be drawn up and exhibited, and the proper authority shall be satisfied that the muster list has been prepared for the ship. It shall be posted in several parts of the ship, and in particular in the crew's quarters.

Regulations XLIV and XLV prescribe the conditions under which musters of the crew and drills shall take place.

CHAPTER IV

RADIOTELEGRAPHY.

ARTICLE 26.

Application and Definition.

- 1 This Chapter applies to all ships engaged on international voyages except cargo ships of less than 1,600 tons gross tonnage.
- 2 For the purposes of this Chapter a cargo ship means any ship not being a passenger ship.

ARTICLE 27

Fitting of Radio Installation.

- 1 All ships to which this Chapter applies shall, unless exempted under Article 28, be fitted with a radiotelegraph installation complying with the provisions of Article 31, as follows:—
 - (a) All passenger ships, irrespective of size :
 - (b) All cargo ships of 1,600 tons gross tonnage and upwards.
- 2 Each Administration may delay the application of the provisions of paragraph 1 (b) to cargo ships belonging to its country of less than 2,000 tons gross tonnage for a period not exceeding five years from the date of the coming into force of the present Convention.

ARTICLE 28

Exemptions from the Requirements of Article 27.

- 1 Each Administration may, if it considers that the route and the conditions of the voyage are such as to render a radiotelegraph installation unreasonable or unnecessary, exempt ships belonging to its country from the requirements of Article 27 as follows:—
 - I. —*Passenger Ships.*

Status: This is the original version (as it was originally enacted).

- (a) Individual passenger ships or classes of passenger ships which, in the course of their voyage, do not go more than—
 - (i) 20 miles from the nearest land; or
 - (ii) 200 miles in the open sea between two consecutive ports.
- (b) Passenger ships which make voyages entirely within the restricted areas specified in the Annex to this Article.

II. —*Cargo Ships.*

Individual cargo ships or classes of cargo ships which, in the course of their voyage, do not go more than 150 miles from the nearest land.

2 Each Administration may, in addition, exempt ships belonging to its country of the following classes :—

I. —Barges in tow and existing sailing ships.

An existing sailing ship is one the keel of which is laid before the 1st July, 1931.

- II. —Ships of primitive build, such as dhows, junks, &c, if it is practically impossible to fit them with a radiotelegraph installation.
- III. —Ships which are not normally engaged on international voyages, but which in exceptional circumstances are required to undertake a single voyage of that kind.

Annex to Article 28.

- 1 The Baltic Sea and approaches thereto East of a line drawn from Utsire (Norway) in the North to Texel (Netherlands) in the South, outside the territorial jurisdiction of the Union of Socialist Soviet Republics.
- 2 The portions of the Gulf of Tartary and the Sea of Okhotsk covered in voyages between ports in Hokkaido and ports in Japanese Sakhalin.
- 3 The Chosen (Tyosen) Strait between a line in the North drawn from Kawajiri Misaki (Cape Natsungu) to Pusan, and a line in the South drawn from Nagasaki to Giffard Island (off the South-West point of Quelpart Island) and thence to Tin To (Amherst Island).
- 4 The Yellow Sea North of Parallel 37° North.
- 5 The Formosa Strait between a line in the North drawn from Fuki Kaku (Syauki Point) to Foochow and a line in the South drawn from South Cape (the South point of Formosa) to Hong Kong.
- 6 The area within the following limits :—
 - Parallel 10° N. from long. 94° E. to the coast of Asia, coast of Asia to Saigon (Cape Tiwan), straight lines between Cape Tiwan, lat. 4° 30' N. long. 110° E., south point of Palawan Island, Palmas (Miangas) Island, lat. 0° long. 140° E., lat. 0° long. 148° E., lat. 10° S. long. 148° E., Cape York, north coast of Australia from Cape York to Port Darwin (Cape Charles), straight lines between Cape Charles, Ashmore Reef (East Island), lat. 10° S. long. 109° E., Christmas Island, lat. 2° N. long. 94° E., lat. 10° N. long. 94° E., outside the territorial jurisdiction of Australia and of the United States of America.
- 7 The Caribbean Sea, outside the territorial jurisdiction of the United States of America, in relation to voyages made by sailing ships only.
- 8 The area of the South Pacific Ocean bounded by the Equator, Meridian 130° W., Parallel 34° S., and the coast of Australia, outside the territorial jurisdiction of Australia.

Status: This is the original version (as it was originally enacted).

- 9 The Tong King Gulf and portions of the China Sea lying to the West of a line drawn from Hong Kong to lat. 17° N. long 110° E., thence due South to lat. 10° N., and thence West to Saigon.
- 10 The portions of the Indian Ocean covered in voyages between ports in Madagascar, Reunion and the Mauritius Islands.
- 11 The portions of the North Atlantic Ocean and Mediterranean Sea covered in voyages between Casablanca (Morocco) and Oran (Algeria) and intermediate ports.

ARTICLE 29

Watches.

1 *Passenger Ships.*

Each passenger ship which, in accordance with Article 27, is required to be fitted with a radiotelegraph installation, shall, for safety purposes, carry a qualified operator, and, if not fitted with an auto-alarm, shall, whilst at sea, keep watches by means of a qualified operator or a certified watcher, as under :—

- (a) All passenger ships under 3,000 tons gross tonnage, as determined by the Administration concerned:
- (b) All passenger ships of 3,000 tons gross tonnage and over, continuous watch.

Each Administration is authorised to exempt passenger ships belonging to its country from 3,000 tons to 5,500 tons gross tonnage, both included, from the requirement of a continuous watch for a period not exceeding one year from the date of the coming into force of the present Convention, provided that during the period of such exemption they shall maintain a watch of at least 8 hours per day.

2 *Cargo Ships*

Each cargo ship which, in accordance with Article 27, is required to be fitted with a radiotelegraph installation, shall, for safety purposes, carry a qualified operator, and, if not fitted with an auto-alarm, shall, whilst at sea, keep watches by means of a qualified operator or a certified watcher, as under:—

- (a) All cargo ships under 3,000 tons gross tonnage, as determined by the Administration concerned:
- (b) Cargo ships from 3,000 to 5,500 tons gross tonnage, both included, at least 8 hours' watch per day:
- (c) Cargo ships over 5,500 tons gross tonnage, continuous watch.

Each Administration is authorised to exempt ships belonging to its country included in (c) above from the requirement of a continuous watch for a period not exceeding one year from the date of the coming into force of the present Convention, provided that during the period of such exemption they shall maintain a watch of at least 8 hours per day.

Each Administration is also authorised to exempt ships belonging to its country from 5,500 tons to 8,000 tons gross tonnage from the requirement of a continuous watch for a further period of one year, provided that during this further period of exemption they shall maintain a watch of at least 16 hours per day.

- ##### 3
- On all ships fitted with an auto-alarm this auto-alarm shall, whilst the ship is at sea, always be in operation when the operator or watcher is not on watch.

Status: This is the original version (as it was originally enacted).

On ships for which the hours of watch are to be determined by the Administration concerned, such watch should be maintained preferably at hours prescribed for radiotelegraph service by the International Radiotelegraph Convention in force.

On ships which are required to keep 8 hours' or 16 hours' watch per day, such watch shall be maintained at the hours prescribed for radiotelegraph service by the International Radiotelegraph Convention in force.

- 4 By " auto-alarm " is meant an automatic alarm receiver which complies with the requirements of Article 19, section 21, of the General Regulations annexed to the International Radiotelegraph Convention, 1927.
- 5 By " qualified operator " is meant a person holding a certificate complying with the provisions of the General Regulations annexed to the International Radiotelegraph Convention in force.
- 6 By " certified watcher " is meant any person holding a watcher's certificate issued under the authority of the Administration.

ARTICLE 30

Watchers.

- 1 A watcher's certificate shall not be granted by a Contracting Government unless the applicant proves that he is capable—
- (a) of receiving and understanding the alarm, distress, safety and urgency signals when these signals occur among a series of other signals;
 - (b) of correct reception by ear of code groups (mixed letters, figures and punctuation marks) at a speed of sixteen groups per minute, each group being composed of five characters and each figure or punctuation mark counting as two characters;
 - (c) of regulating the receivers used in the ship's radiotelegraph installation.
- 2 The Contracting Governments undertake to take steps to ensure that certified watchers observe the secrecy of correspondence.

ARTICLE 31

Technical Requirements.

The radiotelegraph installations required by Article 27 above and the direction-finding apparatus required by Article 47 shall comply with the following requirements:—

- 1 The ship's station must be placed in accordance with the detailed Regulations of the Government of the country to which the ship belongs, in the upper part of the ship in a position of the greatest possible safety, as high as practicable above the deepest load water line.
- 2 There shall be provided, between the bridge of the ship and the wireless telegraph room, means of communication either by voice pipe or by telephone or in some other manner equally efficient.
- 3 A reliable clock with a seconds hand must be provided in the wireless telegraph room.
- 4 A reliable emergency light must be provided in the wireless telegraph room.

Status: This is the original version (as it was originally enacted).

- 6 The installation shall comprise a main installation and an emergency (reserve) installation. If, however, the main installation complies with all the requirements of an emergency (reserve) installation the latter is not then obligatory.
- 6 The main and emergency (reserve) installations must be capable of transmitting and receiving on the frequencies (wave lengths) and types of waves assigned by the International Radiotelegraph Convention in force for the purpose of distress and safety of navigation to ships compulsorily fitted with radiotelegraph installations in accordance with the present Convention.
- 7 The main and emergency (reserve) transmitters shall have a note frequency of at least 100.
- 8 The main transmitter shall have a normal range of 100 nautical miles, that is to say, it must be capable of transmitting clearly perceptible signals from ship to ship over a range of at least 100 nautical miles by day under normal conditions and circumstances, the receiver being assumed to be one employing a rectifier of the crystal type without amplification.(1)
- 9 Sufficient power must be available in a ship station at all times to operate the main radiotelegraph installation efficiently under normal conditions over the above range.
- 10 All parts of the emergency (reserve) installation shall be placed in the upper part of the ship in a position of the greatest possible safety, as high above the deepest load water line as practicable. The emergency (reserve) installation must be provided with a source of energy independent of the propelling power of the ship and of the main electricity system and must be capable of being put into operation rapidly and of working for at least six continuous hours.

For the emergency (reserve) installation, the normal range as defined in paragraph 8 above must be at least 80 nautical miles for ships required to maintain a continuous watch and at least 50 nautical miles for all other ships.(1)

- (1) Unless a more precise and practical method is available to determine the range of transmitters it is recommended that, as a guide, the following relations between the range in nautical miles (from ship to ship under normal conditions in daytime) and the power of the ship transmitter in metre amperes for 500 kilocycles per second (600 m.) be used :—

100 nautical miles	60 M A
80 nautical miles	45 M A
50 nautical miles	25 MA

M being the actual height in metres of the aerial from its highest point to the load line.

A being the current in amperes measured at the base of the aerial in case of B, or fully modulated A2, transmitters.

- (1) Unless a more precise and practical method is available to determine the range of transmitters it is recommended that, as a guide, the following relations between the range in nautical miles (from ship to ship under normal conditions in daytime) and the power of the ship transmitter in metre amperes for 500 kilocycles per second (600 m.) be used :—

100 nautical miles	60 M A
80 nautical miles	45 M A
50 nautical miles	25 MA

M being the actual height in metres of the aerial from its highest point to the load line.

A being the current in amperes measured at the base of the aerial in case of B, or fully modulated A2, transmitters.

Status: This is the original version (as it was originally enacted).

- 11 The receiving installation must permit of the reception of such of the waves used for the transmission of time signals and meteorological messages as may be considered necessary by the Administration.
- 12 The receiver must be so arranged as to be capable of maintaining reception by means of a rectifier of the crystal type.
- 13 In ships in which watch is kept by means of an automatic alarm receiver a means of giving audible warning shall be provided in the wireless telegraph room, in the wireless operator's cabin, and on the bridge, which shall operate continuously after the receiver has been operated by the alarm signal or distress call until stopped. Only one switch for stopping the warning shall be provided and this shall be situated in the wireless telegraph room.
- 14 In such ships the wireless operator, when going off watch, shall connect the automatic alarm receiver to the aerial and test its efficiency. He shall report to the master or the officer on watch on the bridge whether it is in working order.
- 15 Whilst the ship is at sea the emergency source of power shall be maintained at its full efficiency and the automatic alarm receiver shall be tested at least once every 24 hours. A statement that both these requirements have been fulfilled must be inserted in the ship's official log daily.
- 16 A wireless log shall be carried by every ship compulsorily equipped with wireless transmitting apparatus. This document shall be kept in the wireless telegraph room, and in it shall be inserted the names of the operators and watchers as well as all incidents and occurrences connected with the wireless service which may appear to be of importance to safety of life at sea, and in particular all distress messages and distress traffic in full.
- 17 The direction-finding apparatus required by Article 47 shall be efficient and capable of receiving clearly perceptible signals and of taking bearings from which the true bearing and direction may be determined. It shall be capable of receiving signals on the frequencies prescribed for distress, direction finding and wireless telegraph beacons by the International Radiotelegraph Convention in force.
- Efficient communication shall be provided between the apparatus and the bridge.

ARTICLE 32

Competence.

The matters governed by the International Radiotelegraph Convention, Washington, 1927, and the Regulations annexed thereto remain, and will continue, subject to the provisions:—

- (1) Of that Convention and of the Regulations annexed thereto, and of any Convention and Regulations which may in the future be substituted therefor;
- (2) Of the present Convention in regard to all the points in which it supplements the aforementioned documents.

CHAPTER V

SAFETY OF NAVIGATION.

ARTICLE 33.

Application.

The provisions of this Chapter referring to ships, unless otherwise expressly provided, apply to all ships on all voyages.

ARTICLE 34

Danger Messages.

The master of every ship which meets with dangerous ice, a dangerous derelict, a dangerous tropical storm or any other direct danger to navigation is bound to communicate the information, by all the means of communication at his disposal, to the ships in the vicinity, and also to the competent authorities at the first point of the coast with which he can communicate. It is desirable that the said information be sent in the manner set out in Regulation XLVI.

Each Administration will take all steps which it thinks necessary to ensure that when intelligence of any of the dangers specified in the previous paragraph is received, it will be promptly brought to the knowledge of those concerned and communicated to other Administrations interested.

The transmission of messages respecting the dangers specified is free of cost to the ships concerned.

ARTICLE 35

Meteorological Services.

The Contracting Governments undertake to encourage the collection of meteorological data by ships at sea, and to arrange for their examination, dissemination and exchange in the manner most suitable for the purpose of aiding navigation.

In particular, the Contracting Governments undertake to co-operate in carrying out, as far as practicable, the following meteorological arrangements:—

- (a) To warn ships of gales, storms and tropical storms, both by the issue of wireless messages and by the display of appropriate signals at coastal points :
- (b) To issue daily, by radio, weather bulletins suitable for shipping, containing data of existing weather conditions and forecasts :
- (c) To arrange for certain selected ships to take meteorological observations at specified hours, and to transmit such observations by wireless telegraphy for the benefit of other ships and of the various official meteorological services; and to provide coast stations for the reception of the messages transmitted:
- (d) To encourage all ship-masters to inform surrounding ships whenever they experience wind force of 10 or above on the Beaufort scale (force 8 or above on the decimal scale).

The information provided for in paragraphs (a) and (b) of this Article will be furnished in form for transmission in accordance with Article 31, sections 1, 3 and 5, and Article 19, section 25, of the General Regulations annexed to the International Radiotelegraph Convention, Washington, 1927, and during transmission " to all stations " of meteorological information, forecasts and

Status: This is the original version (as it was originally enacted).

warnings, all ship stations must conform to the provisions of Article 31, section 2, of those General Regulations.

Weather observations from ships addressed to national meteorological services will be transmitted with the priority specified in Article 3, Additional Regulations, International Radiotelegraph Convention, Washington, 1927.

Forecasts, warnings, synoptic and other meteorological reports intended for ships shall be issued and disseminated by the national service in the best position to serve various zones and areas, in accordance with mutual arrangements made by the countries concerned.

Every endeavour will be made to obtain a uniform procedure in regard to the international meteorological services specified in this Article, and, as far as is practicable, to conform to the recommendations made by the International Meteorological Organization, to which organization the Contracting Governments may refer for study and advice any meteorological questions which may arise in carrying out the present Convention.

ARTICLE 36

Ice Patrol. Derelicts.

The Contracting Governments undertake to continue a service of ice patrol and a service for study and observation of ice conditions in the North Atlantic. Further, they undertake to take all practicable steps to ensure the destruction or removal of derelicts in the northern part of the Atlantic Ocean east of the line drawn from Cape Sable to a point in latitude 34° N. longitude 70° W. if this destruction or removal is considered necessary at the time.

The Contracting Governments undertake to provide not more than three vessels for these three services. During the whole of the ice season they shall be employed in guarding the south-eastern, southern and south-western limits of the regions of icebergs in the vicinity of the Great Bank of Newfoundland for the purpose of informing trans-Atlantic and other passing vessels of the extent of this dangerous region; for the observation and study of ice conditions in general; for the destruction or removal of derelicts; and for the purpose of affording assistance to vessels and crews requiring aid within the limits of operation of the patrol vessels.

During the rest of the year the study and observation of ice conditions shall be maintained as advisable, and one vessel shall always be available for the search for, and destruction or removal of derelicts.

ARTICLE 37

Ice Patrol. Management and Cost.

The Government of the United States is invited to continue the management of these services of ice patrol, study and observation of ice conditions, and derelict destruction and removal. The Contracting Governments specially interested in these services, whose names are given below, undertake to contribute to the expense of maintaining and operating these services in the following proportions :—

		Per cent.
Belgium	2	
Canada	3	
Denmark	2	

Status: This is the original version (as it was originally enacted).

	Per cent.
France	6
Germany	10
Great Britain and Northern Ireland	40
Italy	6
Japan	1
Netherlands	5
Norway	3
Spain	1
Sweden	2
Union of Socialist Soviet Republics	1
United States of America	18

Each of the Contracting Governments has the right to discontinue its contribution to the expense of maintaining and operating these services after the 1st September, 1932. Nevertheless, the Contracting Government which avails itself of this right will continue responsible for the expense of working up to the 1st September following the date of giving notice of intention to discontinue its contribution. To take advantage of the said right it must give notice to the other Contracting Governments at least six months before the said 1st September; so that, to be free from this obligation on the 1st September, 1932, it must give notice on the 1st March, 1932, at the latest, and similarly for each subsequent year.

If, at any time, the United States Government should not desire to continue these services, or if one of the Contracting Governments should express a wish to relinquish responsibility for the pecuniary contribution defined above, or to have its percentage of obligation altered, the Contracting Governments shall settle the question in accordance with their mutual interests.

The Contracting Governments which contribute to the cost of the three above-mentioned services shall have the right by common consent to make from time to time such alterations in the provisions of this Article and of Article 36 as appear desirable.

ARTICLE 38

Speed near Ice.

When ice is reported on, or near, his course, the master of every ship at night is bound to proceed at a moderate speed or to alter his course so as to go well clear of the danger zone.

ARTICLE 39

North Atlantic Routes.

The practice of following recognised routes across the North Atlantic in both directions has contributed to safety of life at sea, but the working of these routes should be further investigated and studied with a view to the introduction of such variations as experience may show to be necessary.

Status: This is the original version (as it was originally enacted).

The selection of the routes and the initiation of action with regard to them is left to the responsibility of the steamship companies concerned. The Contracting Governments will assist the companies, when requested to do so, by placing at their disposal any information bearing on the routes which may be in the possession of the

The Contracting Governments undertake to impose on the companies the obligation to give public notice of the regular routes which they propose their vessels should follow, and of any changes made in these routes; they will also use their influence to induce the owners of all vessels crossing the Atlantic to follow, so far as circumstances will permit, the recognised routes, and to induce the owners of all vessels crossing the Atlantic bound to or from ports of the United States via the vicinity of the Great Bank of Newfoundland to avoid, as far as practicable, the fishing banks of Newfoundland north of latitude 43° N. during the fishing season, and to pass outside regions known or believed to be endangered by ice.

The Administration managing the ice patrol service is requested to report to the Administration concerned any ship which is observed not to be on any regular, recognised or advertised route, or which crosses the above-mentioned fishing banks during the fishing season, or which, when proceeding to or from ports of the United States, passes through regions known or believed to be endangered by ice.

ARTICLE 40

Collision Regulations.

The Contracting Governments agree that the alterations in the International Regulations for Preventing Collisions at Sea shown in Annex II are desirable and ought to be made. The Government of the United Kingdom of Great Britain and Northern Ireland is requested to forward full particulars of the alterations to the other Governments who have accepted the International Regulations for Preventing Collisions at Sea, and ascertain whether they will adopt these alterations; to report the results to the Governments represented at this Conference, and to endeavour to arrange that the revised regulations shall come in force on the 1st July, 1931.

ARTICLE 41

Helm Orders.

The Contracting Governments agree that after midnight on the 30th June, 1931, helm or steering orders, i.e., orders to the steersman, shall on all their ships be given in the direct sense, e.g., when the ship is going ahead an order containing the word "starboard" or "right" or any equivalent of "starboard" or "right" shall only be used when it is intended, on ships as at present generally constructed and arranged, that the wheel, the rudder-blade and the head of the ship, shall all move to the right.

ARTICLE 42

Misuse of Distress Signals.

The use of an international distress signal, except for the purpose of indicating that a vessel is in distress, and the use of any signal which may be confused with an international distress signal, are prohibited on every ship.

Status: This is the original version (as it was originally enacted).

ARTICLE 43

Alarm, Distress and Urgency Signals.

The alarm signal and the distress signal may only be used by ships in serious and imminent danger which require immediate assistance. In all other cases in which assistance is required, or in which a vessel desires to issue a warning that it may become necessary to send out the alarm signal or the distress signal at a later stage, use must be made of the urgency signal (XXX) established by the International Radiotelegraph Convention, Washington, 1927.

If a ship has sent out the alarm or distress signal and subsequently finds that assistance is no longer required such ship shall immediately notify all stations concerned as provided for by the Radiotelegraph Convention in force.

ARTICLE 44

Speed of Distress Messages.

The speed of transmission of messages in connection with cases of distress, urgency or safety, shall not exceed 16 words per minute.

ARTICLE 45

Distress Messages. Procedure.

- 1 The master of a ship on receiving on his ship a wireless distress signal from any other ship, is bound to proceed with all speed to the assistance of the persons in distress, unless he is unable, or in the special circumstances of the case, considers it unreasonable or unnecessary to do so, or unless he is released under the provisions of paragraphs 3 and 4 of this Article.
- 2 The master of a ship in distress, after consultation, so far as may be possible, with the masters of the ships which answer his call for assistance, has the right to requisition such one or more of those ships as he considers best able to render assistance, and it shall be the duty of the master or masters of the ship or ships requisitioned to comply with the requisition by continuing to proceed with all speed to the assistance of the persons in distress.
- 3 A master shall be released from the obligation imposed by paragraph 1 of this Article as soon as he is informed by the master of the ship requisitioned, or, where more ships than one are requisitioned, all the masters of the ships requisitioned, that he or they are complying with the requisition.
- 4 A master shall be released from the obligation imposed by paragraph 1 of this Article, and, if his ship has been requisitioned, from the obligation imposed by paragraph 2 of this Article, if he is informed by a ship which has reached the persons in distress that assistance is no longer necessary.
- 5 If a master of a ship, on receiving a wireless distress call from another ship, is unable, or in the special circumstances of the case considers it unreasonable or unnecessary to go to the assistance of that other ship, he must immediately inform the master of that other ship accordingly, and enter in his log-book his reasons for failing to proceed to the assistance of the persons in distress.
- 6 The provisions of this Article do not prejudice the International Convention for the unification of certain rules with respect to Assistance and Salvage at Sea,

Status: This is the original version (as it was originally enacted).

signed at Brussels on the 23rd September, 1910, particularly the obligation to render assistance imposed by Article 11 of that Convention.

ARTICLE 46

Signalling Lamp.

All ships of over 150 tons gross tonnage, when engaged on international voyages, shall have on board an efficient signalling lamp.

ARTICLE 47

Direction-finding Apparatus.

Every passenger ship of 5,000 tons gross tonnage and upwards shall, within two years from the date on which the present Convention comes in force, be provided with an approved direction-finding apparatus (radio compass), complying with the provisions of Article 31 (17) of the present Convention.

ARTICLE 48

Manning.

The Contracting Governments undertake, each for its national ships, to maintain, or, if it is necessary, to adopt, measures for the purpose of ensuring that, from the point of view of safety of life at sea, all ships shall be sufficiently and efficiently manned.

CHAPTER VI

CERTIFICATES.

ARTICLE 49.

Issue of Certificates.

A certificate called a *Safety Certificate* shall be issued, after inspection and survey, to every passenger ship which complies in an efficient manner with the requirements of Chapters II, III and IV of the Convention.

A certificate called a *Safety Radiotelegraphy Certificate* shall be issued after inspection to every ship other than a passenger ship which complies in an efficient manner with the requirements of Chapter IV of the present Convention.

A certificate called an *Exemption Certificate* shall be issued to every ship to which exemption is granted by a Contracting Government under, and in accordance with, the provisions of Chapters II, III and IV of the present Convention.

The inspection and survey of ships, so far as regards the enforcement of the provisions of the present Convention and the annexed Regulations applicable to such ships and the granting of exemptions therefrom, shall be carried out by officers of the country in which the ship is registered, provided that the Government of each country may entrust the inspection and survey of its ships either to surveyors nominated for this purpose or to organisations recognised by it. In every case the Government concerned fully guarantees the completeness and efficiency of the inspection and survey.

Status: This is the original version (as it was originally enacted).

A Safety Certificate, Safety Radiotelegraphy Certificate, and Exemption Certificate shall be issued either by the Government of the country in which the ship is registered or by any person or organisation duly authorised by that Government. In every case that Government assumes full responsibility for the certificate.

ARTICLE 50

Issue of Certificate by another Government.

A Contracting Government may, at the request of the Government of a country in which a ship coming under the present Convention is registered, cause that ship to be surveyed, and, if satisfied that the requirements of the present Convention are complied with, issue a Safety Certificate or Safety Radio-telegraphy Certificate to such ship, under its own responsibility. Any certificate so issued must contain a statement to the effect that it has been issued at the request of the Government of the country in which the ship is registered, and it shall have the same force and receive the same recognition as a certificate issued under Article 49 of the present Convention.

ARTICLE 51

Form of Certificates.

All certificates shall be drawn up in the official language or languages of the country by which they are issued.

The form of the certificates shall be that of the models given in Regulation XLVII. The arrangement of the printed part of the standard certificates shall be exactly reproduced in the certificates issued, or in certified copies thereof, and the particulars inserted by hand shall in the certificates issued, or in certified copies thereof, be inserted in Roman characters and Arabic figures.

The Contracting Governments undertake to communicate one to another a sufficient number of specimens of their certificates for the information of their officers. This exchange shall be made, so far as possible, before the 1st January, 1932.

ARTICLE 52

Duration of Certificates.

Certificates shall not be issued for a period of more than twelve months.

If a ship at the time when its certificate expires is not in a port of the country in which it is registered the certificate may be extended by a duly authorised officer of the country to which the ship belongs; but such extension shall be granted only for the purpose of allowing the ship to complete its return voyage to its own country, and then only in cases in which it appears proper and reasonable so to do.

No certificate shall be extended for a longer period than five months, and a ship to which such extension is granted shall not, on returning to its own country, be entitled by virtue of such extension to leave the country again without having obtained a new certificate.

Status: This is the original version (as it was originally enacted).

ARTICLE 53

Acceptance of Certificates.

Certificates issued under the authority of a Contracting Government shall be accepted by the other Contracting Governments for all purposes covered by the present Convention. They shall be regarded by the other Contracting Governments as having the same force as the certificates issued by them to their own ships.

ARTICLE 54

Control.

Every ship holding a certificate issued under Article 49 or Article 50 is subject, in the ports of the other Contracting Governments to control by officers duly authorised by such Governments in so far as this control is directed towards verifying that there is on board a valid certificate, and if necessary, that the conditions of the vessel's seaworthiness correspond substantially with the particulars of that certificate, that is to say, so that the ship can proceed to sea without danger to the passengers and the crew.

In the event of this control giving rise to intervention of any kind, the officer carrying out the control shall forthwith inform the Consul of the country in which the ship is registered of all the circumstances in which intervention is deemed to be necessary.

ARTICLE 55

Privileges.

The privileges of the present Convention may not be claimed in favour of any ship unless it holds a proper valid certificate.

ARTICLE 56

Qualification of Certificate.

If in the course of a particular voyage the ship has on board a number of crew and passengers less than the maximum number which the ship is licensed to carry, and is in consequence, in accordance with the provisions of the present Convention, free to carry a smaller number of life-boats and other life-saving appliances than that stated in the certificate, a memorandum may be issued by the officers or other authorised persons referred to in Articles 49 and 52 above.

This memorandum shall state that in the circumstances there is no infringement of the provisions of the present Convention. It shall be annexed to the certificate and shall be substituted for it in so far as the life-saving appliances are concerned. It shall be valid only for the particular voyage in regard to which it is issued.

CHAPTER VII

GENERAL PROVISIONS.

ARTICLE 57.

Equivalents.

Where in the present Convention it is provided that a particular fitting, appliance or apparatus, or type thereof, shall be fitted or carried in a ship, or that any particular arrangement shall be adopted, any Administration may accept in substitution therefor any other fitting, appliance or apparatus, or type thereof, or any other arrangement, provided that such Administration shall have been satisfied by suitable trials that the fitting, appliance or apparatus, or type thereof, or the arrangement substituted is at least as effective as that specified in the present Convention.

Any Administration which so accepts a new fitting, appliance or apparatus, or type thereof, or new arrangement, shall communicate the fact to the other Administrations, and, upon request, the particulars thereof, together with a report on the trials made.

ARTICLE 58

Laws, Regulations, Reports.

The Contracting Governments undertake to communicate to each other—

- (1) the text of laws, decrees and regulations which shall have been promulgated on the various matters within the scope of the present Convention;
- (2) all available official reports or official summaries of reports in so far as they show the results of the provisions of the present Convention, provided always that such reports or summaries are not of a confidential nature.

The Government of the United Kingdom of Great Britain and Northern Ireland is invited to serve as an intermediary for collecting all this information and for bringing it to the knowledge of the other Contracting Governments.

ARTICLE 59

Measures taken after Agreement.

Where the present Convention provides that a measure may be taken after agreement between all or some of the Contracting Governments, the Government of the United Kingdom of Great Britain and Northern Ireland is invited to approach the other Contracting Governments with a view to ascertaining whether they accept such proposals as may be made by any Contracting Government for effecting such a measure, and to inform the other Contracting Governments of the results of the enquiries thus made.

ARTICLE 60

Prior Treaties and Conventions.

- 1 The present Convention replaces and abrogates the Convention for the Safety of Life at Sea, which was signed at London on the 20th January, 1914.
- 2 All other treaties, conventions and arrangements, relating to safety of life at sea, or matters appertaining thereto, at present in force between Governments parties to

Status: This is the original version (as it was originally enacted).

the present Convention, shall continue to have full and complete effect during the terms thereof as regards—

- (a) ships to which the present Convention does not apply;
- (b) ships to which the present Convention applies, in respect of subjects for which it has not expressly provided.

To the extent, however, that such treaties, conventions or arrangements conflict with the provisions of the present Convention, the provisions of the present Convention shall prevail.

- 3 All subjects which are not expressly provided for in the present Convention remain subject to the legislation of the Contracting Governments.

ARTICLE 61

Modifications Future Conferences.

- 1 Modifications of the present Convention which may be deemed useful or necessary improvements may be at any time proposed by any Contracting Government to the Government of the United Kingdom of Great Britain and Northern Ireland, and such proposals shall be communicated by the latter to all the other Contracting Governments, and if any such modifications are accepted by all the Contracting Governments (including Governments which have deposited ratifications or accessions which have not yet become effective) the present Convention shall be modified accordingly.

- 2 Conferences for the purpose of revising the present Convention shall be held at such times and places as may be agreed upon by the Contracting Governments.

A Conference for this purpose shall be convoked by the Government of the United Kingdom of Great Britain and Northern Ireland whenever, after the present Convention has been in force for five years, one-third of the Contracting Governments express a desire to that effect.

CHAPTER VIII

FINAL PROVISIONS.

ARTICLE 62.

Application to Colonies, &c.

- 1 A Contracting Government may, at the time of signature, ratification, accession or thereafter, by a declaration in writing addressed to the Government of the United Kingdom of Great Britain and Northern Ireland, declare its desire that the present Convention shall apply to all or any of its colonies,' overseas territories, protectorates or territories under suzerainty or mandate, and the present Convention shall apply to all the territories named in such declaration, two months after the date of the receipt thereof, but failing such declaration the present Convention will not apply to any such territories.

- 2 A Contracting Government may at any time by a notification in writing addressed to the Government of the United Kingdom of Great Britain and Northern Ireland express its desire that the present Convention shall cease to apply to all or any of its colonics, overseas territories, protectorates or territories under suzerainty or

Status: This is the original version (as it was originally enacted).

mandate to which the present Convention shall have, under the provisions of the preceding paragraph, been applicable for a period of not less than five years, and in such case the present Convention shall cease to apply one year after the date of the receipt of such notification by the Government of the United Kingdom of Great Britain and Northern Ireland to all territories mentioned therein.

- 3 The Government of the United Kingdom of Great Britain and Northern Ireland shall inform all the other Contracting Governments of the application of the present Convention to any colony, overseas territory, protectorate or territory under suzerainty or mandate under the provisions of paragraph 1 of this Article, and of the cessation of any such application under the provisions of paragraph 2, stating in each case the date from which the present Convention has become or will cease to be applicable.

ARTICLE 63

Authentic Texts. Ratification.

The present Convention of which both the English and French texts shall be authentic shall bear this day's date.

The present Convention shall be ratified.

The instruments of ratification shall be deposited in the archives of the Government of the United Kingdom of Great Britain and Northern Ireland which will notify all the other signatory or acceding Governments of all ratifications deposited and the date of their deposit.

ARTICLE 64

Accession.

A Government (other than the Government of a territory to which Article 62 applies) on behalf of which the present Convention has not been signed shall be allowed to accede thereto at any time after the Convention has come into force. Accessions may be effected by means of notifications in writing addressed to the Government of the United Kingdom of Great Britain and Northern Ireland, and shall take effect three months after their receipt.

The Government of the United Kingdom of Great Britain and Northern Ireland shall inform all signatory and acceding Governments of all accessions received and of the date of their receipt.

A Government which intends to accede to the present Convention but desires to add an area to those specified in the Annex to Article 28 shall, before notifying its accession, inform the Government of the United Kingdom of Great Britain and Northern Ireland of its desire for communication to all the other Contracting Governments. If all the Contracting Governments signify their assent thereto, the area shall be added to those mentioned in the aforesaid Annex when such Government notifies its accession.

ARTICLE 65

Date of coming in Force.

The present Convention shall come into force on the 1st July, 1931, as between the Governments which have deposited their ratifications by that date, and provided that at least five ratifications have been deposited with the Government of the United Kingdom of Great Britain and Northern Ireland. Should five ratifications not have been deposited on that date, the present Convention shall come into force three months after the date on which the fifth ratification is deposited.

Status: This is the original version (as it was originally enacted).

Ratifications deposited after the date on which the present Convention has come into force shall take effect three months after the date of their deposit.

ARTICLE 66

Denunciation.

The present Convention may be denounced on behalf of any Contracting Government at any time after the expiration of five years from the date on which the Convention comes into force in so far as that Government is concerned. Denunciation shall be effected by a notification in writing addressed to the Government of the United Kingdom of Great Britain and Northern Ireland, which will notify all the other Contracting Governments of all denunciations received and of the date of their receipt.

A denunciation shall take effect twelve months after the date on which notification thereof is received by the Government of the United Kingdom of Great Britain and Northern Ireland.

ANNEX I

REGULATIONS.

CONSTRUCTION.

REGULATION I

Definitions.

- (1) The *subdivision loadline* is the waterline used in determining the subdivision of the ship.

The *deepest subdivision* loadline is that which corresponds to the greatest draught.

- (2) The *length of the ship* is the length measured between perpendiculars taken at the extremities of the deepest subdivision loadline.

- (3) The *breadth of the ship* is the extreme width from outside of frame to outside of frame at or below the deepest subdivision loadline.

- (4) The *bulkhead deck* is the uppermost deck up to which the transverse watertight bulkheads are carried.

- (5) The *margin line* is a line drawn parallel to the bulkhead deck at side and 3 inches (76 millimetres) below the upper surface of that deck at side.

- (6) The *draught* is the vertical distance from the top of keel amidships to the subdivision loadline in question.

- (7) The *permeability* of a space is the percentage of that space which can be occupied by water.

The volume of a space which extends above the margin line shall be measured only to the height of that line.

- (8) The *machinery space* is to be taken as extending from the top of keel to the margin line and between the extreme main transverse watertight bulkheads bounding the spaces devoted to the main and auxiliary propelling machinery, boilers when installed, and all permanent coal bunkers.

- (9) *Passenger spaces* are those which are provided for the accommodation and use of passengers, excluding baggage, store, provision and mail rooms.

For the purposes of Regulations III and IV, spaces provided below the margin line for the accommodation and use of the crew shall be regarded as passenger spaces.

- (10) In all cases *volumes* shall be calculated to moulded lines.

REGULATION II

Floodable Length.

- (1) The floodable length at any point of the length of a ship shall be determined by a method of calculation which takes into consideration the form, draught and other characteristics of the ship in question.

Status: This is the original version (as it was originally enacted).

- (2) In a ship with a continuous bulkhead deck, the floodable length at a given point is the maximum portion of the length of the ship, having its centre at the point in question, which can be flooded under the definite assumptions hereafter set forth in Regulation III without the ship being submerged beyond the margin line.
- (3) In the case of a ship not having a continuous bulkhead deck, the floodable length at any point may be determined to an assumed continuous margin line, up to which, having regard to sinkage and trim after damage, the sides of the ship and the bulkheads concerned are carried watertight.

REGULATION III

Permeability.

- (1) The definite assumptions referred to in Regulation II relate to the permeabilities of the spaces below the margin line.

In determining the floodable length, a uniform average permeability shall be used throughout the whole length of each of the following portions of the ship below the margin line :—

- (a) the machinery space as defined in Regulation I (8);
 - (b) the portion forward of the machinery space; and
 - (c) the portion abaft the machinery space.
- (2) (a) For steamships the uniform average permeability throughout the machinery space shall be determined from the formula—

$$80 + 12 \cdot 5 \left(\frac{a - c}{v} \right)$$

, where

- a = volume of the passenger spaces, as defined in Regulation I (9), which are situated below the margin line within the limits of the machinery space.
 - c = volume of between deck spaces below the margin line within the limits of the machinery space which are appropriated to cargo, coal or stores.
 - v = whole volume of the machinery space below the margin line.
- (b) For ships propelled by internal combustion engines, the uniform average permeability shall be taken as 5 greater than that given by the above formula.
 - (c) Where it is shown to the satisfaction of the Administration that the average permeability, as determined by detail calculation, is less than that given by the formula, the calculated value may be substituted. For the purposes of such calculation, the permeabilities of passenger spaces, as defined in Regulation I (9), shall be taken as 95, that of all cargo, coal and store spaces as 60, and that of double bottom, oil fuel and other tanks at such values as may be approved in each case by the Administration.
- (3) The uniform average permeability throughout the portion of the ship before (or abaft) the machinery space shall be determined from the formula—

Status: This is the original version (as it was originally enacted).

$$63 + 35 \frac{a}{v}$$

, where

- a = volume of the passenger spaces, as defined in Regulation I (9), which are situated below the margin line, before (or abaft) the machinery space, and
- v = whole volume of the portion of the ship below the margin line before (or abaft) the machinery space.

- (4) If a between deck compartment between two watertight transverse bulkheads contains any passenger or crew space, the whole of that compartment, less any space completely enclosed within permanent steel bulkheads and appropriated to other purposes, shall be regarded as passenger space. If, however, the passenger or crew space in question is completely enclosed within permanent steel bulkheads, only the space so enclosed need be considered as passenger space.

REGULATION IV

Permissible Length of Compartments.

- (1) *Factor of Subdivision.*—The maximum permissible length of a compartment having its centre at any point in the ship's length is obtained from the floodable length by multiplying the latter by an appropriate factor called the factor of subdivision.

The factor of subdivision shall depend on the length of the ship, and for a given length shall vary according to the nature of the service for which the ship is intended. It shall decrease in a regular and continuous manner—

- (a) as the length of the ship increases, and
- (b) from a factor A, applicable to ships primarily engaged in the carriage of cargo, to a factor B, applicable to ships primarily engaged in the carriage of passengers.

The variations of the factors A and B shall be expressed by the following formulae (i) and (ii), where L is the length of the ship as defined in Regulation I (2) :—

L in feet.

$$A = \frac{190}{L - 198} + .18 \text{ (L = 430 and upwards).}$$

L in metres.

$$A = \frac{58.2}{L - 60} + .18 \text{ (L = 131 and upwards).} \dots\dots\dots(i)$$

L in feet.

$$B = \frac{100}{L - 138} + .18 \text{ (L = 260 and upwards).}$$

L in metres.

Status: This is the original version (as it was originally enacted).

$$B = \frac{30 \cdot 3}{L - 42} + \cdot 18 \text{ (L = 79 and upwards).} \dots\dots\dots(ii)$$

(2) *Criterion of Service.*—For a ship of given length the appropriate factor of subdivision shall be determined by the Criterion of Service Numeral (hereinafter called the Criterion Numeral) as given by the following formulae (iii) and (iv), where:—

- C_s = the Criterion Numeral;
- L = length of the ship, as defined in Regulation I (2);
- M = the volume of the machinery space, as defined in Regulation I (8); with the addition thereto of the volume of any permanent oil fuel bunkers which may be situated above the inner bottom and before or abaft the machinery space;
- P = the whole volume of the passenger spaces below the margin line, as defined in Regulation I (9);
- V = the whole volume of the ship below the margin line;
- P₂ = KN, where :—
 - N = number of passengers for which the ship is to be certified, and
 - K has the following values:—

	<i>Value of K.</i>
Length in feet and volumes in cubic feet	.6L.
Length in metres and volumes in cubic metres	.056 L.

Where the value of KN is greater than the sum of P and the whole volume of the actual passenger spaces above the margin line, the lower figure may be taken provided that the value of P₁ used is not less than 2/3 KN.

When P₁ is greater than P

$$C_s = 72 \frac{M + 2P_1}{V + P_1 - P} \dots\dots\dots(iii)$$

and in other cases

$$C_s = 72 \frac{M + 2P}{V} \dots\dots\dots(iv)$$

For ships not having a continuous bulkhead deck the volumes are to be taken up to the actual margin lines used in determining the floodable lengths.

(3) *Rules for Subdivision.*—

- (a) *The subdivision abaft the fore peak* of ships 430 feet (131 metres) in length and upwards having a criterion numeral of 23 or less shall be governed by the factor A given by formula (i); of those having a criterion numeral of 123 or more by the factor B given by formula (ii); and of those having a criterion

Status: This is the original version (as it was originally enacted).

numeral between 23 and 123 by the factor F obtained by linear interpolation between the factors A and B, using the formula :—

$$F = A - \frac{(A - B)(C_s - 23)}{100} \dots\dots\dots(v)$$

Where the factor F is less than .40 and it is shown to the satisfaction of the Administration to be impracticable to comply with the factor F in a machinery compartment of the ship, the subdivision of such compartment may be governed by an increased factor, which, however, shall not exceed .40.

- (b) *The subdivision abaft the fore peak* of ships less than 430 feet (131 metres) but not less than 260 feet (79 metres) in length having a criterion numeral equal to S, where

$$S = \frac{9382 - 20L}{34} \text{ (L in feet)} = \frac{3574 - 25L}{13} \text{ (L in metres)}$$

shall be governed by the factor unity; of those having a criterion numeral of 123 or more by the factor B given by the formula (ii); of those having a criterion numeral between S and 123 by the factor F obtained by linear interpolation between unity and the factor B, using the formula:—

$$F = 1 - \frac{(1 - B)(C_s - S)}{123 - S} \dots\dots\dots(vi)$$

- (c) *The subdivision abaft the fore peak* of ships less than 430 feet (131 metres) but not less than 260 feet (79 metres) in length and having a criterion numeral less than S, and of all ships less than 260 feet (79 metres) in length shall be governed by the factor unity, unless it is shown to the satisfaction of the Administration to be impracticable to comply with this factor in any part of the ship, in which case, the Administration may allow such relaxation as may appear to be justified, having regard to all the circumstances.
- (c) The provisions of sub-paragraph (c) shall apply also to ships of whatever length, which are to be certified to carry a number of passengers exceeding 12 but not exceeding

$$\frac{L^2 \text{ (in feet)}}{7000} \left(\frac{L^2 \text{ (in metres)}}{650} \right) \text{ or } 50, \text{ whichever is the less.}$$

REGULATION V.

Special Rules concerning Subdivision.

- (1) A compartment may exceed the permissible length determined by the rules of Regulation IV provided the combined length of each pair of adjacent compartments to which the compartment in question is common does not exceed either the floodable length or twice the permissible length, whichever is the less.

If one of the two adjacent compartments is situated inside the machinery space, and the second is situated outside the machinery space, and the average permeability of the portion of the ship in which the second is situated differs from that of the

Status: This is the original version (as it was originally enacted).

machinery space, the combined length of the two compartments shall be adjusted to the mean average permeability of the two portions of the ship in which the compartments are situated.

Where the two adjacent compartments have different factors of subdivision, the combined length of the two compartments shall be determined proportionately.

- (2) In ships 430 feet (131 metres) in length and upwards, one of the main transverse bulkheads abaft the fore peak shall be fitted at a distance from the forward perpendicular which is not greater than the permissible length.
- (3) A main transverse bulkhead may be recessed provided that all parts of the recess lie inboard of vertical surfaces on both sides of the ship, situated at a distance from the shell plating equal to one-fifth the breadth of the ship, as defined in Regulation I (3), and measured at right angles to the centreline at the level of the deepest subdivision loadline.

Any part of a recess which lies outside these limits shall be dealt with as a step in accordance with the following paragraph.

- (4) A main transverse bulkhead may be stepped provided that—
 - (a) the combined length of the two compartments, separated by the bulkhead in question, does not exceed 90 per cent. of the floodable length, or
 - (b) additional subdivision is provided in way of the step to maintain the same measure of safety as that secured by a plane bulkhead.
- (5) Where a main transverse bulkhead is recessed or stepped, an equivalent plane bulkhead shall be used in determining the subdivision.
- (6) If the distance between two adjacent main transverse bulkheads, or their equivalent plane bulkheads, or the distance between the transverse planes passing through the nearest stepped portions of the bulkheads, is less than 10 feet (3.05 metres) plus 2 per cent. of the length of the ship, only one of these bulkheads shall be regarded as forming part of the subdivision of the ship in accordance with the provisions of Regulation IV.
- (7) Where a main transverse watertight compartment contains local subdivision and it can be shown to the satisfaction of the Administration that, after any assumed side damage extending over a length of 10 feet (3.05 metres) plus 2 per cent. of the length of the ship, the whole volume of the main compartment will not be flooded, a proportionate allowance may be made in the permissible length otherwise required for such compartment.

In such a case the volume of effective buoyancy assumed on the undamaged side shall not be greater than that assumed on the damaged side.

- (8) Where it is proposed to fit watertight decks, inner skins or longitudinal bulkheads, watertight or non-watertight, the Administration shall be satisfied that the safety of the ship will not be diminished in any respect, particularly having in view the possible listing effect of flooding in way of such structural arrangements.

Status: This is the original version (as it was originally enacted).

REGULATION VI

Peak and Machinery Space Bulkheads, Shaft Tunnels, &c.

- (1) Every ship shall have a forepeak or collision bulkhead, which shall be watertight up to the bulkhead deck. This bulkhead shall be fitted not less than 5 per cent. of the length of the ship, and not more than 10 feet (3.05 metres) plus 5 per cent. of the length of the ship from the forward perpendicular.

If the ship has a long forward superstructure, the forepeak bulkhead shall be extended weathertight to the deck next above the bulkhead deck. The extension need not be fitted directly over the bulkhead below, provided it is at least 5 per cent. of the length of the ship from the forward perpendicular, and the part of the bulkhead deck which forms the step is made effectively weathertight.

- (2) An afterpeak bulkhead, and bulkheads dividing the machinery space, as defined in Regulation I (8), from the cargo and passenger spaces forward and aft, shall also be fitted and made watertight up to the bulkhead deck. The afterpeak bulkhead may, however, be stopped below the bulkhead deck, provided the degree of safety of the ship as regards subdivision is not thereby diminished.
- (3) In all cases stern tubes shall be enclosed in watertight spaces. The stern gland shall be situated within a watertight shaft tunnel or other space of such volume that if flooded by leakage through the stern gland the margin line will not be submerged.

REGULATION VII

Assigning, Marking and Recording of Subdivision Loadlines.

- (1) The subdivision loadlines assigned and marked under the provisions of Article 5 of the Convention shall be recorded in the Safety Certificate, and shall be distinguished by the notation C.I for the principal passenger condition, and C.2, 0.3, &c, for the alternative conditions.
- (2) The freeboard corresponding to each of these loadlines inserted in the Safety Certificate shall be measured at the same position and from the same deck line as the freeboards determined by recognised National Freeboard Regulations.
- (3) In no case shall any subdivision loadline mark be placed above the deepest loadline in salt water as determined by the strength of the ship and/or recognised National Freeboard Regulations.
- (4) Whatever may be the position of the subdivision loadline marks, a ship shall in no case be loaded so as to submerge the loadline mark appropriate to the season and locality as determined by the recognised National Freeboard Regulations.

REGULATION VIII

Construction and Initial Testing of Watertight Bulkheads, &c.

- (1) Watertight subdivision bulkheads, whether transverse or longitudinal, shall be constructed in such a manner that they shall be capable of supporting with a proper margin of resistance, the pressure due to a head of water up to the margin line in way of each bulkhead. The construction of these bulkheads shall be to the satisfaction of the Administration.

Status: This is the original version (as it was originally enacted).

- (2) Steps and recesses in bulkheads shall be watertight and as strong as the bulkhead at the place where each occurs.

Where frames or beams pass through a watertight deck or bulkhead, such deck or bulkhead shall be made structurally watertight without the use of wood or cement.
- (3) Testing main compartments by filling them with water is not compulsory. A complete examination of the bulkheads shall be made by a surveyor; and, in addition, a hose test shall be made in all cases.
- (4) The fore peak shall be tested with water to a head up to the deepest subdivision loadline.
- (5) Double bottoms, including duct keels, and inner skins are to be subjected to a head of water up to the margin line.
- (6) Tanks which are intended to hold liquids, and which form part of the subdivision of the ship, shall be tested for tightness with water to a head up to the deepest subdivision loadline or to a head corresponding to two-thirds of the depth from the top of keel to the margin line in way of the tanks, whichever is the greater; provided that in no case shall the test head be less than 3 feet (.92 metre) above the top of the tank.

REGULATION IX

Openings in Watertight Bulkheads.

- (1) The number of openings in watertight bulkheads shall be reduced to the minimum compatible with the design and proper working of the ship; satisfactory means shall be provided for closing these openings.
- (2) (a) Where pipes, scuppers, electric-light cables, &c, are carried through watertight subdivision bulkheads, arrangements shall be made to ensure the integrity of the watertightness of the bulkheads.
(b) Sluice valves shall not be permitted in the watertight subdivision bulkheads.
- (3) (a) No doors, manholes, or access openings are permitted—
(i) in the collision bulkhead below the margin line;
(ii) in watertight transverse bulkheads dividing a cargo space from an adjoining cargo space or from a permanent or reserve bunker, except as provided in paragraph (7).
(b) The collision bulkhead may be pierced below the margin line by not more than one pipe for dealing with fluid in the fore peak tank, provided that the pipe is fitted with a screwdown valve capable of being operated from above the bulkhead deck, the valve chest being secured inside the fore peak to the collision bulkhead.
- (4) (a) Watertight doors fitted in bulkheads between permanent and reserve bunkers, shall be always accessible, except as provided in sub-paragraph 9(b) for between deck bunker doors.
(b) Satisfactory arrangements shall be made, by means of screens or otherwise, to prevent the coal from interfering with the closing of watertight bunker doors.
- (5) Within the machinery space and apart from bunker and shaft tunnel doors, not more than one door may be fitted in each main transverse bulkhead for

Status: This is the original version (as it was originally enacted).

intercommunication. These doors shall be located so as to have the sills as high as practicable.

- (6)
 - (a) The only types of watertight doors permissible are hinged doors, sliding doors, and doors of other equivalent patterns, excluding plate doors secured only by bolts.
 - (b) A hinged door shall be fitted with catches workable from each side of the bulkhead.
 - (c) A sliding door may have a horizontal or vertical motion. If required to be hand operated only, the gearing shall be capable of being worked at the door itself and also at an accessible position above the bulkhead deck.
 - (d) If a door is required to be closed by dropping or by the action of a dropping weight, it shall be fitted with a suitable arrangement to regulate the closing movement, and the gearing shall be so arranged that the door can be released both at the door itself and at an accessible position above the bulkhead deck. Hand gear shall also be provided, so arranged as to operate at the door itself and above the bulkhead deck, and also, so that after being disengaged for dropping, it can be quickly re-engaged from either the upper or the lower position.
 - (e) If a door is required to be power operated from a central control, the gearing shall be so arranged that the door can be operated by power also at the door itself. The arrangement shall be such that the door will close automatically if opened by the local control after being closed from the central control, and also such that any door can be kept closed by local arrangements, which will prevent that door from being opened from the central control. Such power operated doors shall be provided with hand gear, workable both at the door itself and from an accessible position above the bulkhead desk.
 - (f) In all classes of doors indicators shall be fitted at all operating stations other than at the door itself, showing whether the door is opened or closed.
- (7)
 - (a) Hinged watertight doors in passenger, crew, and working spaces are only permitted above a deck, the underside of which, at its lowest point at side, is at least 7 feet (2-13 metres) above the deepest subdivision loadline, and they are not permitted in those spaces below such deck.
 - (b) Hinged watertight doors of satisfactory construction may be fitted in bulkheads dividing cargo between decks spaces, in levels in which side cargo doors would be permitted under the provisions of Regulation X (11). These doors shall be closed before the voyage commences and shall be kept closed during the voyage, and the time of opening such doors in port and of closing them before the ship leaves port shall be entered in the official log book. Where it is proposed to fit such doors, the number and arrangements shall receive the special consideration of the Administration, and a statement shall be required from the owners certifying as to the absolute necessity of such doors.
- (8) All other watertight doors shall be sliding doors.
- (9)
 - (a) When any watertight doors which may be sometimes opened at sea, excluding those at the entrances of tunnels, are fitted in the main transverse watertight bulkheads at such a height that their sills are below the deepest subdivision loadline, the following rules shall apply :—
 - (I) When the number of such doors exceeds five all the watertight sliding doors shall be power operated and shall be capable of

Status: This is the original version (as it was originally enacted).

being simultaneously closed from a station situated on the bridge, simultaneous closing of these doors being preceded by a warning sound signal.

- (II) When the number of such doors does not exceed five—
- (i) if the criterion numeral does not exceed 30, all the watertight sliding doors may be operated by hand only;
 - (ii) if the criterion numeral exceeds 30, but does not exceed 60, all the watertight sliding doors may be either dropping doors fitted with releasing and hand gear operated at the door and from above the bulkhead deck or doors operated by power;
 - (iii) if the criterion numeral exceeds 60, all the watertight sliding doors shall be operated by power.
- (b) If watertight doors which have sometimes to be open at sea for the purpose of trimming coal are fitted between bunkers in the between-decks below the bulkhead deck, these doors shall be operated by power. The opening and closing of these doors shall be recorded in the official log book.
- (c) When trunkways in connection with refrigerated cargo are carried through more than one main transverse watertight bulkhead, and the sills of the openings are less than 7 feet (2-13 metres) above the deepest subdivision loadline, the watertight doors at such openings shall be operated by power.
- (10) Portable plates on bulkheads shall not be permitted except in machinery spaces. Such plates shall always be in place before the ship leaves port, and shall not be removed at sea except in case of urgent necessity. The necessary precautions shall be taken in replacing them to ensure that the joints shall be watertight.
- (11) All watertight doors shall be kept closed during navigation except when necessarily opened for the working of the ship, and shall always be ready to be immediately closed.
- (12) Where trunkways or tunnels for access from crew's accommodation to the stokehold, for piping, or for any other purpose are carried through main transverse watertight bulkheads, they shall be watertight and in accordance with the requirements of Regulation XII. The access to at least one end of each such tunnel or trunkway, if used as a passage at sea, shall be through a trunk extending watertight to a height sufficient to permit access above the margin line. The access to the other end of the trunkway or tunnel may be through a watertight door of the type required by its location in the ship. Such trunkways or tunnels shall not extend through the first subdivision bulkhead abaft the collision bulkhead.

Where it is proposed to fit tunnels or trunkways for forced draft, piercing main transverse watertight bulkheads, these shall receive the special consideration of the Administration.

REGULATION X

Openings in Ship's Sides below the Margin Line.

- (1) The arrangement and efficiency of the means for closing any opening in the ship's sides shall be consistent with its intended purpose and the position in which it is fitted and generally to the satisfaction of the Administration.
- (2) (a) If in a between decks, the sills of any sidescuttles are below a line drawn parallel to the bulkhead deck at side and having its lowest point 2 ½ per

Status: This is the original version (as it was originally enacted).

cent. of the breadth of the ship above the deepest subdivision loadline, all sidescuttles in that between deck shall be of a non-opening type.

- (b) If in a between decks, the sills of any sidescuttles other than those required to be of a non-opening type by sub-paragraph (a) are below a line drawn parallel to the bulkhead deck at side and having its lowest point at a height of 12 feet (3.66 metres) plus 2 ½ per cent. of the breadth of the ship above the deepest subdivision loadline, all sidescuttles in that between decks shall be of such construction as will effectively prevent any person opening them without the consent of the master of the ship.
- (c) Other sidescuttles may be of any ordinary opening type.
- (d) If in a between decks, the sills of any of the sidescuttles referred to in sub-paragraph (b) are below a line drawn parallel to the bulkhead deck at side and having its lowest point 4 ½ feet (1.37 metres), plus 2 ½ per cent. of the breadth of the ship above the loadline at which the ship is floating on her departure from any port, all the sidescuttles in that between decks shall be closed watertight and locked before the ship leaves port and they shall not be opened during navigation.

The time of opening such sidescuttles in port and of closing and locking them before the ship leaves port shall be entered in the official log book.

The Administration may indicate the limiting mean draught at which these sidescuttles will have their sills above the line defined in this paragraph and at which it will be permissible to open them at sea on the responsibility of the master. In tropical waters in fair weather this limiting draught may be increased by 1 foot (.305 metres).

- (3) Efficient hinged inside deadlights arranged so that they can be easily and effectively closed and secured watertight shall be fitted to all sidescuttles—
 - (a) which are required to be of a non-opening type;
 - (b) which are to be fitted within one-eighth of the ship's length of the forward perpendicular;
 - (c) which are to be fitted in positions defined in sub-paragraph (2)(b);
 - (d) which will not be accessible during navigation;
 - (e) which are to be fitted in spaces intended for the accommodation of sailors and firemen;
 - (f) which are to be fitted in spaces intended for the accommodation of steerage passengers.
- (4) Sidescuttles fitted below the bulkhead deck, other than those referred to in the preceding paragraph, shall be fitted with efficient inside deadlights which may be portable and stowed adjacent to the sidescuttles.
- (5) Sidescuttles and their deadlights, which will not be accessible during navigation, shall be closed and secured before the ship proceeds to sea.
- (6) No sidescuttles shall be fitted in any spaces which are appropriated exclusively to the carriage of cargo or coal.
- (7) Automatic ventilating sidescuttles shall not be fitted in the ship's sides below the margin line without the special sanction of the Administration.
- (8) All machinery and other inlets and discharges in the ship's sides shall be arranged so as to prevent the accidental admission of water into the ship.

Status: This is the original version (as it was originally enacted).

- (9) The number of scuppers, sanitary discharges and other similar openings in the ship's sides shall be reduced to the minimum either by making each discharge serve for as many as possible of the sanitary and other pipes, or in any other satisfactory manner.
- (10) Discharges led through the ship's sides from spaces below the margin line shall be fitted with efficient and accessible means for preventing water from passing inboard. It is permissible to have for each separate discharge either one automatic non-return valve fitted with a positive means of closing it from above the bulkhead deck, or alternatively, two automatic non-return valves without such means, the upper of which valves is so situated above the deepest subdivision loadline as to be always accessible for examination under service conditions.

Where a positive action valve is fitted, the operating position above the bulkhead deck shall always be readily accessible and means shall be provided for indicating whether the valve is open or closed.

- (11) Gangway, cargo and coaling ports fitted below the margin line shall be of sufficient strength. They shall be effectively closed and secured watertight before the ship leaves port, and shall be kept closed during navigation.

Cargo and coaling ports which are to be fitted partly or entirely below the deepest subdivision loadline shall receive the special consideration of the Administration.

- (12) The inboard opening of each ash-shoot, rubbish-shoot, &c, shall be fitted with an efficient cover.

If the inboard opening is situated below the margin line, the cover shall be watertight, and in addition an automatic non-return valve shall be fitted in the shoot in an easily accessible position above the deepest subdivision loadline. When the shoot is not in use both the cover and the valve shall be kept closed and secured.

REGULATION XI

Construction and Initial Tests of Watertight Doors, Sidescuttles, die.

- (1) The design, materials and construction of all watertight doors, sidescuttles, gangway, cargo and coaling ports, valves, pipes, ash-shoots and rubbish-shoots referred to in these Regulations shall be to the satisfaction of the Administration.
- (2) Each watertight door shall be tested by water pressure to a head up to the margin line. The test shall be made before the ship is put in service, either before or after the door is fitted.

REGULATION XII

Construction and Initial Tests of Watertight Decks, Trunks, &c.

- (1) Watertight decks, trunks, tunnels, duct keels and ventilators shall be of the same strength as watertight bulkheads at corresponding levels. The means used for making them watertight, and the arrangements adopted for closing openings in them, shall be to the satisfaction of the Administration. Watertight ventilators and trunks shall be carried at least up to the margin line.
- (2) After completion a hose or flooding test shall be applied to watertight decks and a hose test to watertight trunks, tunnels and ventilators.

Status: This is the original version (as it was originally enacted).

REGULATION XIII

Periodical Operation and Inspection of Watertight Doors, &c.

In all new and existing ships drills for the operating of watertight doors, sidescuttles, valves, and closing mechanisms of scuppers, ash-shoots and rubbish-shoots, shall take place weekly. In ships in which the voyage exceeds one week in duration a complete drill shall be held before leaving port, and others thereafter at least once a week during the voyage, provided that all watertight power doors and hinged doors, in main transverse bulkheads, in use at sea shall be operated daily.

The watertight doors and all mechanisms and indicators connected therewith, and all valves the closing of which is necessary to make a compartment watertight, shall be periodically inspected at sea, at least once a week.

REGULATION XIV

Entries in the Official Log Book.

In all new and existing ships hinged doors, portable plates, sidescuttles, gangway, cargo and coaling ports and other openings, which are required by these Regulations to be kept closed during navigation, shall be closed before the ship leaves port. The time of closing, and the time of opening (if permissible under these Regulations), shall be recorded in the official log book.

A record of all drills and inspections required by Regulation XIII shall be entered in the official log book with an explicit record of any defects which may be disclosed.

REGULATION XV

Double Bottoms.

- (1) In ships 200 feet (61 metres) and under 249 feet (76 metres) in length a double bottom shall be fitted at least from the machinery space to the fore peak bulkhead, or as near thereto as practicable.
- (2) In ships 249 feet (76 metres) and under 330 feet (100 metres) in length a double bottom shall be fitted at least outside the machinery space, and shall extend to the fore and after peak bulkheads, or as near thereto as practicable.
- (3) In ships 330 feet (100 metres) in length and upwards a double bottom shall be fitted amidships, and shall extend to the fore and after peak bulkheads, or as near thereto as practicable.
- (4) Where a double bottom is required to be fitted the inner bottom shall be continued out to the ship's sides in such a manner as to protect the bottom to the turn of bilge.

Such protection will be deemed satisfactory if the line of intersection of the outer edge of the margin plate with the bilge plating is not lower at any part than a horizontal plane passing through the point of intersection with the frame line amidships of a transverse diagonal line inclined at 25 degrees to the base line and cutting it at a point one-half the ship's moulded breadth from the middle line.

- (5) Wells constructed in the double bottom in connection with the drainage arrangements shall not extend downwards more than necessary, nor shall they be less than 18 inches (457 millimetres) from the outer bottom or from the inner edge of the margin plate. A well extending to the outer bottom is, however, permitted at the after end of the shaft tunnel of screw ships.

Status: This is the original version (as it was originally enacted).

REGULATION XVI

Fire-resisting Bulkheads.

Ships shall be fitted above the bulkhead deck with fire-resisting bulkheads which shall be continuous from side to side of the ship and arranged to the satisfaction of the Administration.

They shall be constructed of metal or other fire-resisting material, effective to prevent for one hour, under the conditions for which the bulkheads are to be fitted in the ship, the spread of fire generating a temperature of 1,500° F. (815° C.) at the bulkhead.

Steps and recesses and the means for closing all openings in these bulkheads shall be fire-resisting and flamtight.

The mean distance between any two adjacent fire-resisting bulkheads in any superstructure shall in general not exceed 131 feet (40 metres).

REGULATION XVII

Side and other Openings, &c., above the Margin Line.

- (1) Sidescuttles, gangway, cargo and coaling ports, and other means for closing openings in the ship's sides above the margin line shall be of efficient design and construction and of sufficient strength having regard to the spaces in which they are fitted and their positions relative to the deepest subdivision loadline.
- (2) The bulkhead deck or a deck above it shall be weathertight in the sense that in ordinary sea conditions water will not penetrate in a downward direction. All openings in the exposed weather deck shall have coamings of ample height and strength, and shall be provided with efficient means for expeditiously closing them weathertight.
- (3) Freeing ports and/or scuppers shall be fitted as necessary for rapidly clearing the weather deck of water under all weather conditions.

REGULATION XVIII

Exits from Watertight Compartments.

- (1) In passenger and crew spaces, practicable means of exit to the open deck shall be provided for the occupants from each watertight compartment.
- (2) Practicable means of escape for the crew shall be provided from each engine room, shaft tunnel, stokehold compartment, and other working spaces, independent of watertight doors.

REGULATION XIX

Pumping Arrangements.

Steamships.

- (1) Ships shall be provided with an efficient pumping plant capable of pumping from and chaining any watertight compartment under all practicable conditions after a casualty whether the ship is upright or listed. For this purpose wing suction will generally be necessary except in narrow compartments at the ends of the ship. Where close ceiling is fitted over the bilges, arrangements shall be made whereby water in the

Status: This is the original version (as it was originally enacted).

compartment may find its way to the suction pipes. Efficient means shall be provided for draining water from insulated holds.

- (2) In addition to the ordinary bilge pump, worked by the main engines, or its equivalent engine room pump, two independent power bilge pumps shall be provided, except that in ships less than 300 feet (91.5 metres) in length, having a criterion numeral less than 30, either two efficient hand pumps of the crank type fitted one forward and one aft, or a portable power pump, may be substituted for one of the additional independent power bilge pumps.

Sanitary, ballast and general service pumps may be accepted as independent power bilge pumps if fitted with the necessary connections to the bilge pumping system.

- (3) Where two or more independent power pumps are required, the arrangement shall be such that at least one power pump will be available for use in all ordinary circumstances in which a vessel may be flooded at sea. One of the power pumps shall, therefore, be an emergency pump of a reliable submersible type. A source of power situated above the bulkhead deck shall be available for this pump in any case of emergency.
- (4) Where practicable, the power bilge pumps shall be placed in separate watertight compartments so arranged or situated that these compartments will not readily be flooded by the same damage. If the engines and boilers are in two or more watertight compartments, the pumps available for bilge service shall be distributed through these compartments as far as is possible.
- (5) With the exception of pumps which may be provided for peak compartments only, each bilge pump, whether operated by hand or by power, shall be arranged to draw water from any hold or machinery compartment in the ship.
- (6) Each independent power bilge pump shall be capable of giving a speed of water through the main bilge pipe of not less than 400 feet (122 metres) per minute, and it shall have a separate direct suction, to the compartment in which it is situated of a diameter not less than that of the bilge main. The direct suction from each independent power bilge pump shall be arranged to pump from either side of the ship.
- (7) Main circulating pumps shall have direct suction connections, provided with non-return valves, to the lowest drainage level in the machinery space, and of a diameter at least two-thirds that of the main sea inlet. Where the fuel is, or may be, coal, and there is no watertight bulkhead between the engines and boilers, a direct discharge overboard shall be fitted from at least one circulating pump, or, alternatively, a by-pass may be fitted to the circulating discharge.
- (8) (a) All pipes from the pumps which are required for draining, cargo or machinery spaces shall be entirely distinct from pipes which may be used for filling or emptying spaces where water or oil is carried.
- (b) Lead pipes shall not be used under coal bunkers or oil fuel storage tanks, nor in boiler or machinery spaces, including motor rooms in which oil settling tanks or oil fuel pump units are situated.
- (9) The Administration shall make rules relating to the diameters of the bilge main and branch pipes which shall be proportioned respectively in relation to the size of the ship and the sizes of the compartments to be drained.
- (10) The arrangement of the bilge and ballast pumping system shall be such as to prevent the possibility of water passing from the sea and from water ballast spaces into the

Status: This is the original version (as it was originally enacted).

cargo and machinery spaces, or from one compartment to another. Special provision shall be made to prevent any deep tank having bilge and ballast connections being inadvertently run up from the sea when containing cargo, or pumped out through a bilge pipe when containing water ballast.

- (11) Provision shall be made to prevent the compartment served by any bilge suction pipe being flooded, in the event of the pipe being severed or otherwise damaged, by collision or grounding, in any other compartment. For this purpose, where the pipe is at any part situated near the side of the ship or in a duct keel, there shall be fitted to the pipe in the compartment containing the open end either a non-return valve, or a screw-down valve which can be operated from a position above the bulkhead deck.
- (12) All distribution boxes, cocks, and valves in connection with the bilge pumping arrangement shall be in positions which are accessible at all times under ordinary circumstances. They shall be so arranged that in the event of flooding the emergency bilge pump may be operative on any compartment. If there is only one system of pipes common to all the pumps, the necessary cocks or valves for controlling the bilge suction must be workable from above the bulkhead deck. If in addition to the main bilge pumping system an emergency bilge pumping system is provided, it shall be independent of the main system and so arranged that the emergency pump is capable of operating on any compartment under flooding conditions.

Motor Ships.

- (13) The bilge pumping arrangements in motor ships shall, so far as practicable, be equivalent to those required for steamships of similar size, except as regards main circulating pumps.

REGULATION XX

Power for Going Astern.

Ships shall have sufficient power for going astern to secure proper control of the ship in all circumstances.

REGULATION XXI

Auxiliary Steering Apparatus.

Ships shall be provided with an auxiliary steering apparatus which, however, may be of less power than the main apparatus, and need not be worked by steam or other mechanical power, provided adequate arrangements for manual operation are practicable. A duplicate main steering power plant shall be considered as an auxiliary steering apparatus within the meaning of this Regulation.

REGULATION XXII

Initial and Subsequent Surveys of Ships.

- (1) Every new or existing ship shall be subjected to the surveys specified below :—
 - (a) A survey before the ship is put in service.
 - (b) A periodical survey once every twelve months.
 - (c) Additional surveys, as occasion arises.
- (2) The surveys referred to above shall be carried out as follows:—

Status: This is the original version (as it was originally enacted).

- (a) *The survey before the ship is put in service* shall include a complete inspection of the hull, machinery and equipments, including the outside of the ship's bottom and the inside and outside of the boilers. This survey shall be such as to ensure that the arrangements, material, and scantlings of the hull, boilers, and their appurtenances, main and auxiliary machinery, life-saving appliances, and other equipments, fully comply with the requirements of the present Convention and of the detailed regulations promulgated as a result thereof by the Government of the country to which the ship belongs for ships of the service for which it is intended. The survey shall also be such as to ensure that the workmanship of all parts of the ship and its equipments is in all respects satisfactory.
 - (b) *The periodical survey* shall include an inspection of the whole of the hull, boilers, machinery, and equipments, including the outside of the ship's bottom. The survey shall be such as to ensure that the ship, as regards the hull, boilers, and their appurtenances, main and auxiliary machinery, life-saving appliances, and other equipments, is in satisfactory condition and fit for the service for which it is intended, and that it complies with the requirements of the present Convention, and of the detailed regulations promulgated as a result thereof by the Government of the country to which the ship belongs.
 - (c) *A survey either general or partial*, according to the circumstances, shall be made every time an accident occurs or a defect is discovered which affects the safety of the ship or the efficiency or completeness of its life-saving appliances or other equipments, or whenever any important repairs or renewals are made. The survey shall be such as to ensure that the necessary repairs or renewals have been effectively made, that the material and workmanship of such repairs or renewals are in all respects satisfactory, and that the ship complies in all respects with the provisions of the present Convention and of the detailed regulations promulgated as a result thereof by the Government of the country to which the ship belongs.
- (3) The detailed regulations referred to in sub-paragraph (2) shall prescribe the requirements to be observed as to the initial and subsequent hydraulic tests to which the main and auxiliary boilers, connections, steam-pipes, high-pressure receivers, and fuel tanks for oil motors are to be submitted, including the test pressure to be applied, and the intervals between two consecutive tests.

Main and auxiliary boilers, connections, tanks and receivers, also steam-piping of more than 3 inches (76 millimetres) internal diameter shall be satisfactorily tested by hydraulic pressure when new. Steam pipes of more than 3 inches (76 millimetres) internal diameter shall be tested by hydraulic pressure periodically.

REGULATION XXIII

Maintenance of Conditions after Survey.

After the survey of the ship as provided in Regulation XXII has been completed no change shall be made in the structural arrangements, machinery, equipments, &c, covered by the survey, without the sanction of the Administration.

Status: This is the original version (as it was originally enacted).

LIFE-SAVING APPLIANCES, &C.

REGULATION XXIV

Standard Types of Boats.

The standard types of boats are classified as follow :—

Class I.—Open boats with rigid sides having either (a) internal buoyancy only, or (b) internal and external buoyancy.

Class II.—(a) Open boats with internal and external buoyancy—upper parts of sides collapsible, and (b) decked boats with either fixed or collapsible watertight bulwarks.

No boat may be approved the buoyancy of which depends upon the previous adjustment of one of the principal parts of the , hull, or which has not a cubic capacity of at least 3.5 cubic metres (equivalent to 125 cubic feet).

No boat may be approved the weight of which when fully laden with persons and equipment exceeds 20,300 kilogrammes (equivalent to 20 tons).

REGULATION XXV

Lifeboats of Class I.

Lifeboats of Class I must have a mean sheer at least equal to four per cent. of their length.

The air-cases of lifeboats of Class I shall be so placed as to secure stability when fully laden under adverse weather conditions.

In boats certified to carry 100 or more persons the volume of the buoyancy shall be increased to the satisfaction of the Administration.

Lifeboats of Class I must also satisfy the following conditions:—

Lifeboats with Internal Buoyancy only.

- (a) The buoyancy of a wooden boat of this type shall be provided by watertight air-cases, the total volume of which shall be at least equal to one-tenth of the cubic capacity of the boat.

The buoyancy of a metal boat of this type shall not be less than that required above for a wooden boat of the same cubic capacity, the volume of watertight air-cases being increased accordingly.

Lifeboats with Internal and External Buoyancy.

- (b) The internal buoyancy of a wooden boat of this type shall be provided by watertight air-cases, the total volume of which is at least equal to seven and a half per cent. of the cubic capacity of the boat.

The external buoyancy may be of cork or of any other equally efficient material, but such buoyancy shall not be obtained by the use of rushes, cork shavings, loose granulated cork or any other loose granulated substance, or by any means dependent upon inflation by air.

If the buoyancy is of cork, its volume, for a wooden boat, shall not be less than thirty-three thousandths of the cubic capacity of the boat; if of any material other than cork,

Status: This is the original version (as it was originally enacted).

its volume and distribution shall be such that the buoyancy and stability of the boat are not less than that of a similar boat provided with buoyancy of cork.

The buoyancy of a metal boat shall be not less than that required above for a wooden boat of the same cubic capacity, the volume of the watertight air-cases and that of the external buoyancy being increased accordingly.

REGULATION XXVI

Boats of Class II.

Boats of Class II must satisfy the following conditions:—

Open Boats with Internal and External Buoyancy—Upper Part of Sides collapsible.

- (a) A boat of this type shall be fitted both with watertight air-cases and with external buoyancy the aggregate volume of which, for each person which the boat is able to accommodate, shall be at least equal to the following amounts :—

	Cubic Decimetres.	Cubic Feet.
Air-cases	43	1.5
External buoyancy (if of cork)	6	0.2

The external buoyancy may be of cork or of any other equally efficient material, but such buoyancy shall not be obtained by the use of rushes, cork shavings, loose granulated cork, or any other loose granulated substance, or by any means dependent upon inflation by air.

If of any material other than cork, its volume and distribution shall be such that the buoyancy and stability of the boat are not less than that of a similar boat provided with buoyancy of cork

A metal boat of this type shall be provided with internal and' external buoyancy to ensure that the buoyancy of the boat shall be at least equal to that of a wooden boat.

The minimum freeboard of boats of this type shall be fixed in relation to their length; and it shall be measured vertically to the top of the solid hull at the side amidships, from the water-level, when the boat is loaded.

The freeboard in fresh water shall not be less than the following amounts:—

Length of Lifeboat.		Minimum Freeboard.	
Metres.	Equivalent in Feet to—	Millimetres.	Equivalent in Inches to—
7.90	26	200	8
8.50	28	225	9
9.15	30	250	10

The freeboard of boats of intermediate lengths is to be found by interpolation.

The collapsible sides must be watertight.

Status: This is the original version (as it was originally enacted).

Decked Boats with either Fixed or Collapsible Watertight Bulwarks.

- (b) (i) *Decked Boats having a Well Deck.*—The area of the well deck of a boat of this type shall be at least 30 per cent. of the total deck area. The height of the well deck above the water-line at all points shall be at least equal to one-half per cent. of the length of the boat, this height being increased to one-and-a-half per cent. of the length of the boat at the ends of the well.

The freeboard of a boat of this type shall be such as to provide for a reserve buoyancy of at least 35 per cent.

- (ii) *Decked Boats having a Flush Deck.*—The minimum freeboard of boats of this type is independent of their lengths and depends only upon their depths. The depth of the boat is to be measured vertically from the underside of the garboard strake to the top of the deck at the side amidships and the freeboard is to be measured from the top of the deck at the side amidships to the water-level when the boat is loaded.

The freeboard in fresh water shall not be less than the following amounts, which are applicable without correction to boats having a mean sheer equal to three per cent. of their length:—

Depth of Lifeboat.		Minimum Freeboard.	
Millimetres.	Equivalent in Inches to—	Millimetres.	Equivalent in Inches to—
310	12	70	2 ³ / ₄
460	18	95	3 ³ / ₄
610	24	130	5 ¹ / ₈
760	30	165	6 ¹ / ₂

For intermediate depths the freeboard is obtained by interpolation.

If the sheer is less than the standard sheer defined above, the minimum freeboard is obtained by adding to the figures in the table one-seventh of the difference between the standard sheer and the actual mean sheer measured at the stem and stern post; no deduction is to be made from the freeboard on account of the sheer being greater than the standard sheer or on account of the camber of the deck.

- (iii) All decked lifeboats shall be fitted with efficient means for clearing the deck of water.

REGULATION XXVII

Motor Boats.

A motor boat carried as part of the life-saving appliances of a vessel, whether required by Regulation XXXVI (2) or not, shall comply with the following conditions :—

- (a) It shall comply with the requirements for a lifeboat of Class I, and proper appliances shall be provided for putting it into the water speedily.
- (b) It shall be adequately provided with fuel, and kept so as to be at all times ready for use.
- (c) The motor and its accessories shall be suitably enclosed to ensure operation under adverse weather conditions, and provision shall be made for going astern.

Status: This is the original version (as it was originally enacted).

- (d) The speed shall be at least six knots when fully loaded in smooth water.

The volume of the internal buoyancy and, where fitted, the external buoyancy shall be increased in sufficient proportion to compensate for the difference between the weight of the motor, the searchlight, and the wireless telegraph installation and their accessories, and the weight of the additional persons which the boat could accommodate if the motor, the searchlight and the wireless telegraph installation and their accessories were removed.

REGULATION XXVIII

Life Rafts.

No type of life raft may be approved unless it satisfies the following conditions:—

- (a) It shall be of approved material and construction;
- (b) It shall be effective and stable when floating either way up;
- (c) It shall be fitted with fixed or collapsible bulwarks of wood, canvas or other suitable material on both sides;
- (d) It shall have a line securely becketed round the outside;
- (e) It shall be of such strength that it can be launched or thrown from the vessel's deck without being damaged, and if to be thrown it shall be of such size and weight that it can be easily handled;
- (f) It shall have not less than 85 cubic decimetres (equivalent to three cubic feet) of air-cases or equivalent buoyancy for each person to be carried thereon;
- (g) It shall have a deck area of not less than 3,720 square centimetres (equivalent to four square feet) for each person to be carried thereon, and it shall effectively support the occupants out of the water;
- (h) The air-cases or equivalent buoyancy shall be placed as near as possible to the sides of the life raft, and such buoyancy shall not be by any means dependent on inflation by air.

REGULATION XXIX

Buoyant Apparatus.

Buoyant apparatus, whether buoyant deck seats, buoyant deck chairs or other buoyant apparatus, shall be deemed sufficient, so far as buoyancy is concerned, for a person or number of persons to be ascertained by dividing the number of kilogrammes of iron which it is capable of supporting in fresh water by 14.5 (equivalent to the number of pounds divided by 32), and if the apparatus depends for its buoyancy on air it shall not require to be inflated before use in an emergency.

The number of persons for whom the apparatus is deemed suitable shall be determined by the least of the numbers ascertained either as above or by the number of 30.5 centimetres (equivalent to one foot) in the perimeter.

Such approved buoyant apparatus shall comply with the following conditions :—

- 1. It shall be constructed with proper workmanship and materials.
- 2. It shall be effective and stable when floating either way up.
- 3. It shall be of such size, strength and weight that it can be handled without mechanical appliances and, if necessary, thrown without damage from the vessel's deck on which it is stowed.
- 4. The air-cases or equivalent buoyancy shall be placed as near as possible to the sides of the apparatus.
- 5. It shall have a line securely becketed round the outside of the apparatus.

Status: This is the original version (as it was originally enacted).

REGULATION XXX

Cubic Capacity of Lifeboats of Class I.

- 1 The cubic capacity of a lifeboat of Class I shall be determined by Stirling's (Simpson's) Rule or by any other method giving the same degree of accuracy. The capacity of a square-sterned boat shall be calculated as if the boat had a pointed stern.
- 2 For example, the capacity in cubic metres (or cubic feet) of a boat, calculated by the aid of Stirling's Rule, may be considered as given by the following formula:—

$$\text{Capacity} = \frac{l}{12} (4A + 2B + 4C)$$

l being the length of the boat in metres (or feet) from the inside of the planking or plating at the stem to the corresponding point at the stern post; in the case of a boat with a square stern, the length is measured to the inside of the transom.

A, *B*, *C* denote respectively the areas of the cross-sections at the quarter length forward, amidships, and the quarter length aft, which correspond to the three points obtained by dividing *l* into four equal parts (the areas corresponding to the two ends of the boat are considered negligible).

The areas *A*, *B*, *C* shall be deemed to be given in square metres (or square feet) by the successive application of the following formula to each of the three cross-sections:—

$$\text{Area} = \frac{h}{12} (a + 4b + 2c + 4d + e)$$

h being the depth measured in metres (or in feet) inside the planking or plating from the keel to the level of the gunwale, or, in certain cases, to a lower level, as determined hereafter.

a, *b*, *c*, *d*, *e*, denote the horizontal breadths of the boat measured in metres (or in feet) at the upper and lower points of the depth and at the three points obtained by dividing *h* into four equal parts (*a* and *e* being the breadths at the extreme points, and *c* at the middle point, of *h*).

- 3 If the sheer of the gunwale, measured at the two points situated at a quarter of the length of the boat from the ends, exceeds 1 per cent. of the length of the boat, the depth employed in calculating the area of the cross-sections *A* or *C* shall be deemed to be the depth amidships plus 1 per cent. of the length of the boat.
- 4 If the depth of the boat amidships exceeds 45 per cent. of the breadth, the depth employed in calculating the area of the midship cross-section *B* shall be deemed to be equal to 45 per cent. of the breadth, and the depth employed in calculating the areas of the quarter length sections *A* and *C* is obtained by increasing this last figure by an amount equal to 1 per cent. of the length of the boat, provided that in no case shall the depths employed in the calculation exceed the actual depths at these points.
- 5 If the depth of the boat is greater than 122 centimetres (equivalent to 4 feet) the number of persons given by the application of this rule shall be reduced in proportion to the ratio of 122 centimetres to the actual depth, until the boat has been satisfactorily tested afloat with that number of persons on board, all wearing life-jackets.

Status: This is the original version (as it was originally enacted).

- 6 Each Administration shall impose, by suitable formulae, a limit for the number of persons allowed in boats with very fine ends and in boats very full in form.
- 7 Each Administration reserves the right to assign to a boat a capacity equal to the product of the length, the breadth and the depth multiplied by 0.6 if it is evident that this formula does not give a greater capacity than that obtained by the above method. The dimensions shall then be measured in the following manner:—
- Length.—From the intersection of the outside of the planking with the stem to the corresponding point at the stern post or, in the case of a square sterned boat, to the after side of the transom.
- Breadth.—From the outside of the planking at the point where the breadth of the boat is greatest.
- Depth.—Amidships inside the planking from the keel to the level of the gunwale, but the depth used in calculating the cubic capacity may not in any case exceed 45 per cent. of the breadth.
- In all cases the shipowner has the right to require that the cubic capacity of the boat shall be determined by exact measurement.
- 8 The cubic capacity of a motorboat is obtained from the gross capacity by deducting a volume equal to that occupied by the motor and its accessories, and, when carried, the wireless telegraphy installation and the searchlight with their accessories.

REGULATION XXXI

Deck Area of Boats of Class II.

- 1 The area of the deck of a decked boat shall be determined by the method indicated below or by any other method giving the same degree of accuracy. The same rule is to be applied in determining the area within the fixed bulwarks of a boat of Class II (a).
- 2 For example, the surface in square metres (or square feet) of a boat may be deemed to be given by the following formula :—

$$\text{Area} = \frac{l}{12} (2a + 1.5b + 4c + 1.5d + 2e)$$

l being the length in metres (or in feet) from the intersection of the outside of the planking with the stem to the corresponding point at the stern post.

a, b, c, d, e denote the horizontal breadths in metres (or in feet) outside the planking at the points obtained by dividing l into four equal parts and sub-dividing the foremost and aftermost parts into two equal parts (a and e being the breadths at the extreme sub-divisions, c at the middle point of the length, and b and d at the intermediate points).

REGULATION XXXII

Marking of Boats, Life Rafts and Buoyant Apparatus.

The dimensions of the boat and the number of persons which it is authorised to carry, shall be marked on it in clear permanent characters. These marks shall be specifically approved by the officers appointed to inspect the ship.

Status: This is the original version (as it was originally enacted).

Life rafts and buoyant apparatus shall be marked with the number of persons in the same manner.

REGULATION XXXIII

Carrying Capacity of Boats.

- 1 The number of persons which a boat of one of the standard types can accommodate is equal to the greatest whole number obtained by dividing the capacity in cubic metres (or cubic feet), or the surface in square metres (or square feet), of the boat by the standard unit of capacity, or unit of surface (according to circumstances), denned below for each type.
- 2 The standard units of capacity and surface for determining the number of persons are as follows:—

Unit of Capacity.	Cubic Metres.	Equivalent in Cubic Feet.
Open boats, Class I (a)	0.283	10
Open boats, Class I (b)	0.255	9
Unit of Surface.	Square Metres.	Equivalent in Square Feet.
Class II	0.325	3 ½

- 3 The Administration may accept, in place of 0.325 or 3 ½, as the case may be, a smaller divisor, if it is satisfied after trial that the number of persons for whom there is seating accommodation in the decked boat in question is greater than the number obtained by applying the above divisor, provided always that the divisor adopted in place of 0.325 or 3 ½, as the case may be, may never be less than 0.280 or 3, as the case may

The Administration which accepts a lower divisor in this way shall communicate to the other Administrations particulars of the trial and drawings of the decked boat in question.

REGULATION XXXIV

Capacity Limits.

No boat shall be marked for a greater number of persons than that obtained in the manner specified in these Regulations. This number shall be reduced—

- (1) when it is greater than the number of persons for which there is proper seating accommodation; the latter number shall be determined in such a way that the persons when seated do not interfere in any way with the use of the oars;
- (2) when, in the case of boats other than those of Class I, the freeboard when the boat is fully loaded is less than the freeboard laid down for each type respectively; the number shall be reduced until the freeboard when the boat is fully loaded is at least equal to the standard freeboard laid down above.

In boats of Class II (b) (i), the raised part of the deck at the sides may be regarded as affording seating accommodation.

Status: This is the original version (as it was originally enacted).

REGULATION XXXV

Equivalent for and Weight of the Persons.

In the tests for determining the number of persons which a boat or life raft can accommodate, each person shall be assumed to be an adult person wearing a life-jacket.

In verifications of freeboard the decked boats shall be loaded with a weight of at least 75 kilogrammes (165 lbs.) for each adult person that the decked boat is authorised to carry.

In all cases two children under 12 years Of age shall be reckoned as one person.

REGULATION XXXVI

Equipment of Boats and Life Rafts.

- 1 The normal equipment of every boat shall consist of :—
- (a) A single banked complement of oars, two spare oars and a steering oar; one set and a half of thole pins or crutches; a boat hook.
 - (b) Two plugs for each plug hole (plugs are not required when proper automatic valves are fitted); a bailer and a galvanised iron bucket.
 - (c) A rudder and a tiller or yoke and yoke lines.
 - (d) Two hatchets.
 - (e) A lamp filled with oil and trimmed.
 - (f) A mast or masts with one good sail at least, and proper gear for each.
 - (g) An efficient compass.
 - (h) A life-line becketed round the outside.
 - (i) A sea-anchor.
 - (j) A painter.
 - (k) A vessel containing four and a half litres (equivalent to one gallon) of vegetable or animal oil. The vessel shall be so constructed that the oil can be easily distributed on the water, and so arranged that it can be attached to the sea-anchor.
 - (l) An airtight receptacle containing one kilogramme (equivalent to two pounds) of provisions for each person.
 - (m) A watertight receptacle provided with a dipper with lanyard containing one litre (equivalent to one quart) of fresh water for each person.
 - (n) At least one dozen self-igniting " red lights " and a box of matches in watertight containers.
 - (o) Half a kilogramme (equivalent to one pound) of condensed milk for each person.
 - (p) A suitable locker for the stowage of the small items of the equipment.
 - (q) Any boat which is certified to carry 100 or more persons shall be fitted with a motor and shall comply with the requirements of Regulation XXVII.

A motor lifeboat need not carry a mast or sails or more than half the complement of oars, but it shall carry two boathooks.

Decked lifeboats shall have no plug-hole, but shall be provided with at least two bilge-pumps.

In the case of a ship which carries passengers in the North Atlantic north of 35° North Latitude, only a proportion of the boats, to be fixed by the Administration,

Status: This is the original version (as it was originally enacted).

need be equipped with masts and sails, and only one-half the quantity of condensed milk need be carried.

- 2 Where the number of lifeboats carried on a ship is more than 13, one shall be a motor boat, and where the number is more than 19, two shall be motor boats. These motor lifeboats shall be fitted with a wireless telegraph installation and a searchlight.

The wireless telegraph installation shall comply with conditions as to range and efficiency to be decided by each Administration.

The searchlight shall include a lamp of at least 80 watts, an efficient reflector and a source of power which will give effective illumination of a light coloured object over a width of about 18 metres (60 feet) at a distance of 180 metres (200 yards) for a total period of six hours, and it shall be capable of working for three hours continuously.

Where the power for the wireless equipment and the searchlight are derived from the same source, this shall be sufficient to provide for the adequate working of both appliances.

- 3 The normal equipment of every approved life raft shall consist of—
- (a) Four oars.
 - (b) Five rowlocks.
 - (c) A self-igniting lifebuoy light.
 - (d) A sea-anchor.
 - (e) A painter.
 - (f) A vessel containing four and a half litres (equivalent to one gallon) of vegetable or animal oil. The vessel shall be so constructed that the oil can be easily distributed on the water, and so arranged that it can be attached to the sea-anchor.
 - (g) An airtight receptacle containing one kilogramme (equivalent to two pounds) of provisions for each person.
 - (h) A watertight receptacle provided with a dipper with lanyard containing one litre (equivalent to one quart) of fresh water for each person.
 - (i) At least one dozen self-igniting red lights and a box of matches in watertight containers.

- 4 In the case of a ship which is engaged in short international voyages, the Administration may exempt the boats from carrying the equipment specified under sub-paragraphs (f), (1) and (o) of paragraph 1 and from the requirements of paragraph 2, and may also exempt the life rafts from carrying the equipment specified in paragraph 3 (g).

REGULATION XXXVII

Stowage and Handling of Boats and Life Rafts.

- 1 Subject to the conditions of Regulation XXXVIII, the lifeboats may be stowed one above the other, or they may, subject to such conditions as the Administration may impose, be fitted one within another, but where boats so fitted require lifting before being launched they shall only be permitted if mechanical power appliances for lifting are provided.

Status: This is the original version (as it was originally enacted).

- (2) The lifeboats and life rafts additional to boats stowed under boats attached to davits may be stowed across a deck, bridge or poop and so secured that they will have the best chance of floating free of the ship if there is no time to launch them.
- (3) As large a number as possible of the additional boats referred to in paragraph 2 shall be capable of being launched on either side of the ship by means of approved appliances for transferring them from one side of the deck to the other.
- (4) Boats may only be stowed on more than one deck on condition that proper measures are taken to prevent boats on a lower deck being fouled by those stowed on a deck above.
- (5) Boats shall not be placed in the bows of the ship or in any positions in which they would be brought into dangerous proximity to the propellers at the time of launching.
- (6) Davits shall be of approved form and so disposed on one or more decks that the boats placed under them can be safely lowered without interference from the operation of any other davits.
- (7) The davits, blocks, falls and all other gear shall be of such strength that the boats can be safely lowered with the full complement of persons and equipment, with the ship listed to 15 degrees either way. The falls shall be long enough to reach the water with the vessel at her Ugh test seagoing draught and with a list of 15 degrees.
- (8) The davits shall be fitted with gear of sufficient power to ensure that the boats, fully equipped and manned, but not otherwise loaded with passengers, can be turned out against the maximum list at which the lowering of the boats is possible.
- (9) The boats attached to the davits shall have the falls ready for service, and means shall be provided for speedily, but not necessarily simultaneously, detaching the boats from the falls.
- (10) Where more than one boat is served by the same set of davits, if the falls are of rope, separate falls shall be provided to serve each boat, but where wire falls are used with mechanical appliances for recovering them, separate falls need not be provided. The appliances used must be such as to ensure lowering the boats in turn and rapidly.

Where mechanical appliances are fitted for the recovery of the falls efficient hand gear shall also be provided.
- 11 On short international voyages where the height of the boat deck above the water line when the vessel is at her lightest sea-going draught does not exceed 4-5 metres (15 feet), the requirements as to strength of davits and turning-out gear in subparagraphs 7, 8 and 10 shall not apply.

REGULATION XXXVIII

Number and Capacity of Boats, Life Rafts, die, and Davits.

- (1) A ship shall be provided with sets of davits in accordance with its length as provided in Column A of the Table in Regulation XXXIX, provided that a-number of sets of davits greater than the number of boats necessary for the accommodation of all the persons on board shall not be required.

Each set of davits shall have a boat of Class I attached to it. If the lifeboats attached to davits do not provide sufficient accommodation for all the persons on board,

Status: This is the original version (as it was originally enacted).

additional lifeboats of one of the standard types shall be provided. One additional lifeboat shall, in the first place, be stowed under each of the boats attached to davits. After these have been fitted other boats shall be carried inboard, but an Administration may, if it is of opinion that life rafts will be more readily available and otherwise more satisfactory than these lifeboats in a case of emergency, allow life rafts to be carried provided that the total capacity of the boats on the ship will be at least up to the minimum capacity required by Column C of the Table in Regulation XXXIX

When in the opinion of the Administration it is neither practicable nor reasonable to place on a ship the number of sets of davits required by Column A of the Table in Regulation XXXIX, the Administration may authorise, under exceptional conditions, a smaller number of sets of davits, provided always that this number shall never be less than the minimum number fixed by Column B of the Table and that the total capacity of the boats on the ship will be at least up to the minimum capacity required by Column C.

- (2) A ship engaged on short international voyages shall be provided with sets of davits in accordance with its length as provided in Column A of the Table in Regulation XXXIX. Each set of davits shall have a boat of Class I attached to it. If the lifeboats attached to davits do not provide the minimum cubic capacity specified in Column D of the Table in Regulation XXXIX or provide accommodation for all persons on board, additional lifeboats of one of the standard types, approved life rafts or other approved buoyant apparatus shall be provided, and the accommodation thus provided shall be sufficient for all on board.

When in the opinion of the Administration it is neither practicable nor reasonable to place on a ship engaged in short international voyages, the number of sets of davits required by Column A of the Table in Regulation XXXIX, the Administration may authorise, under exceptional conditions, a smaller number of sets of davits, provided always that this number shall never be less than the minimum number fixed by Column B of the Table, and that the total capacity of the boats on the ship will be at least up to the minimum capacity required by Column D.

REGULATION XXXIX

Table relating to davits and lifeboat capacity.

The following table fixes, according to the length of the ship—

- (A) *The minimum number of sets of davits to be provided to each of which must be attached a boat of Class I in accordance with Regulation XXXVIII above.*
- (B) *The smaller number of sets of davits which may be authorised exceptionally under Regulation XXXVIII.*
- (C) *The minimum life-boat capacity required, including the life-boats attached to davits and the additional boats, in accordance with Regulation XXXVIII.*
- (D) *The minimum life-boat capacity required for a ship engaged in short international voyages.*

Status: This is the original version (as it was originally enacted).

Registered Length of the Ship.		(A.) Minimum Number of Sets of Davits.	(B.) Smaller Number of Sets of Davits authorised exceptionally.	(C.) Minimum Capacity of Lifeboats.		(D.) Minimum Capacity of Lifeboats.	
Metres.	Feet.			Cubic Metres.	Cubic Feet.	Cubic Metres.	Cubic Feet.
31 and under 37	100 and under 120	2	2	28	980	11	400
37 and under 43	120 and under 140	2	2	35	1,220	17	600
43 and under 49	140 and under 160	2	2	44	1,550	24	850
49 and under 53	160 and under 175	3	3	63	1,880	33	1,150
53 and under 58	175 and under 190	3	3	68	2,390	37	1,300
58 and under 63	190 and under 205	4	4	78	2,740	41	1,450
63 and under 67	205 and under 220	4	4	94	3,330	45	1,600
67 and under 70	220 and under 230	6	4	110	3,900	48	1,700
70 and under 75	230 and under 245	5	4	129	4,560	52	1,850
75 and under 78	245 and under 255	6	5	144	5,100	60	2,100
78 and under 82	255 and under 270	6	5	160	5,640	68	2,400
82 and under 87	270 and under 285	7	5	175	6,190	76	2,700
87 and under 91	285 and under 300	7	5	196	6,930	85	3,000
91 and under 96	300 and under 315	8	6	214	7,550	94	3,300

Note on (A) and (B).—When the length of the ship exceeds 314 metres (equivalent to 1,030 feet) the Administration shall determine the minimum number of sets of davits for that ship; full particulars of its decision shall be communicated to the other Administrations.

Note on (C) and (D).—For the purposes of this table the capacity of a boat of Class II is obtained by multiplying the number of persons for which the boat is certified by 0-283 to obtain the capacity in cubic metres and by 10 to obtain the capacity in cubic feet.

Note on (D).—When the length of a ship is under 31 metres (equivalent to 100 feet) or over 168 metres (equivalent to 550 feet) the cubic capacity of the lifeboats shall be prescribed by the Administration.

Status: This is the original version (as it was originally enacted).

Registered Length of the Ship.		(A.) Minimum Number of Sets of Davits.	(B.) Smaller Number of Sets of Davits authorised exceptionally.	(C.) Minimum Capacity of Lifeboats.		(D.) Minimum Capacity of Lifeboats.	
Metres.	Feet.			Cubic Metres.	Cubic Feet.	Cubic Metres.	Cubic Feet.
96 and under 101	315 and under 330	8	6	235	8,290	105	3,700
101 and under 107	330 and under 350	9	7	255	9,000	116	4,100
107 and under 113	350 and under 370	9	7	273	9,630	126	4,400
113 and under 119	370 and under 390	10	7	301	10,650	133	4,700
119 and under 125	390 and under 410	10	7	331	11,700	144	5,100
125 and under 133	410 and under 435	12	9	370	13,060	156	5,500
133 and under 140	435 and under 460	12	9	408	14,430	170	6,000
140 and under 149	460 and under 490	14	10	451	15,920	185	6,550
149 and under 159	490 and under 520	14	10	490	17,310	201	7,100
159 and under 168	520 and under 550	16	12	530	18,720	217	7,650
168 and under 177	550 and under 580	16	12	576	20,350		
177 and under 186	580 and under 610	18	13	620	21,900		
186 and under 195	610 and under 640	18	13	671	23,700		
195 and under 204	640 and under 670	20	14	717	25,350		

Note on (A) and (B).—When the length of the ship exceeds 314 metres (equivalent to 1,030 feet) the Administration shall determine the minimum number of sets of davits for that ship; full particulars of its decision shall be communicated to the other Administrations.

Note on (C) and (D).—For the purposes of this table the capacity of a boat of Class II is obtained by multiplying the number of persons for which the boat is certified by 0.283 to obtain the capacity in cubic metres and by 10 to obtain the capacity in cubic feet.

Note on (D).—When the length of a ship is under 31 metres (equivalent to 100 feet) or over 168 metres (equivalent to 550 feet) the cubic capacity of the lifeboats shall be prescribed by the Administration.

Status: This is the original version (as it was originally enacted).

Registered Length of the Ship.		(A.) Minimum Number of Sets of Davits.	(B.) Smaller Number of Sets of Davits authorised exceptionally.	(C.) Minimum Capacity of Lifeboats.		(D.) Minimum Capacity of Lifeboats.	
Metres.	Feet.			Cubic Metres.	Cubic Feet.	Cubic Metres.	Cubic Feet.
204 and under 213	670 and under 700	20	14	766	27,050		
213 and under 223	700 and under 730	22	15	808	28,560		
223 and under 232	730 and under 760	22	15	854	30,180		
232 and under 241	760 and under 790	24	17	908	32,100		
241 and under 250	790 and under 820	24	17	972	34,350		
250 and under 261	820 and under 855	26	18	1,031	36,450		
261 and under 271	855 and under 890	26	18	1,097	38,750		
271 and under 282	890 and under 925	28	19	1,160	41,000		
282 and under 293	925 and under 960	28	19	1,242	43,880		
293 and under 303	960 and under 996	30	20	1,312	46,350		
303 and under 314	995 and under 1,030	30	20	1,380	48,750		

Note on (A) and (B).—When the length of the ship exceeds 314 metres (equivalent to 1,030 feet) the Administration shall determine the minimum number of sets of davits for that ship; full particulars of its decision shall be communicated to the other Administrations.

Note on (C) and (D).—For the purposes of this table the capacity of a boat of Class II is obtained by multiplying the number of persons for which the boat is certified by 0.283 to obtain the capacity in cubic metres and by 10 to obtain the capacity in cubic feet.

Note on (D).—When the length of a ship is under 31 metres (equivalent to 100 feet) or over 168 metres (equivalent to 550 feet) the cubic capacity of the lifeboats shall be prescribed by the Administration.

REGULATION XL

Life-Jackets and Life-Buoys.

1 A life-jacket shall satisfy the following requirements:—

- (a) It shall be constructed with proper workmanship and materials;

Status: This is the original version (as it was originally enacted).

(b) It shall be capable of supporting in fresh water for 24 hours 7.5 kilogrammes of iron (equivalent to 16 ½ pounds);

(c) It shall be reversible.

Life-jackets the buoyancy of which depends on air compartments are prohibited.

2 A lifebuoy shall satisfy the following requirements :—

(a) It shall be of solid cork or any other equivalent material;

(b) It shall be capable of supporting in fresh water for 24 hours at least 14-6 kilogrammes (equivalent to 32 pounds) of iron.

Life-buoys filled with rushes, cork shavings or granulated cork, or any other loose granulated material, or whose buoyancy depends upon air compartments which require to be inflated, are prohibited.

3 The minimum number of life-buoys with which ships are to be provided is fixed by the following table :—

Length of the Ship. Metres.	Equivalent in Feet.	Minimum Number of Buoys.
Under 61	Under 200	8
61 and under 122	200 and under 400	12
122 and under 183	400 and under 600	18
183 and under 244	600 and under 800	24
244 and over	800 and over	30

4 All the buoys shall be fitted with beackets securely seized. At least one buoy on each side shall be fitted with a life-line of at least 27-6 metres (15 fathoms) in length. Not less than one-half of the total number of life-buoys, and in no case less than six, shall be provided with efficient self-igniting lights which cannot be extinguished in water, and these shall be kept near the buoys to which they belong, with the necessary means of attachment.

5 All the life-buoys and life-jackets shall be so placed as to be readily accessible to the persons on board; their position shall be plainly indicated so as to be known to the persons concerned.

The life-buoys shall always be capable of being rapidly cast loose and shall not be permanently secured in any way.

REGULATION XLI

Certificated Lifeboatmen.

In order to obtain the special lifeboatman's certificate provided for in Article 22 of the present Convention, the applicant must prove that he has been trained in all the operations connected with launching lifeboats and the use of oars; that he is acquainted with the practical handling of the boats themselves; and, further, that he is capable of understanding and answering the orders relative to lifeboat service.

There shall be for each boat or life-raft a number of lifeboat-men at least equal to that specified in the following table :—

Status: This is the original version (as it was originally enacted).

	The Minimum Number of Certificated Life-boatmen shall be :
If the Prescribed Complement is :	
Less than 41 persons	2
From 41 to 61 persons	3
From 62 to 85 persons	4
Above 85 persons	5

REGULATION XLII

Manning of Boats.

A deck officer or certificated lifeboatman shall be placed in charge of each boat or life-raft and a second in command shall also be nominated. The person in charge shall have a list of its crew, and shall see that the men placed under his orders are acquainted with their several duties.

A man capable of working the motor shall be assigned to each motor boat.

A man capable of working the wireless and searchlight installations shall be assigned to boats carrying this equipment.

The duty of seeing that the boats, life-rafts and buoyant apparatus and other lifesaving apparatus are at all times ready for use shall be assigned to one or more officers.

REGULATION XLIII

Fire Detection and Extinction.

- 1 An efficient patrol system shall be maintained, so that any outbreak of fire may be promptly detected. In addition, a fire alarm or fire detecting system shall be provided, which will automatically indicate or register at one or more points or stations where it can be most quickly observed by officers and crew, the presence or indication of fire in any part of the ship not accessible to the patrol system.
- 2 Every ship shall be provided with powerful pumps, operated by steam or other means. On ships of less than 4,000 tons gross there shall be two, and on larger ships three of these pumps. Each of the pumps shall be capable of delivering a sufficient quantity of water in two powerful jets simultaneously in any given part of the ship, and shall be available for immediate use before the ship leaves port.
- 3 The service pipes shall permit of two powerful jets of water being simultaneously directed on any given part of a deck occupied by passengers and crew, when the watertight and fire-resisting doors are closed. The service pipes and hoses shall be of ample size and made of suitable material. The branches of the pipes shall be so placed on each deck that the fire hose can be easily coupled to them.
- 4 Provision shall be made whereby at least two powerful jets of water can be rapidly and simultaneously directed into any space containing cargo. In addition, arrangements shall be made whereby smothering gas sufficient to give a minimum volume of free gas equal to 30 per cent. of the gross volume of the largest hold in the ship can be promptly conveyed by a permanent piping system into each compartment in which cargo is carried. Steam in adequately equivalent proportion may be accepted in place of smothering gas on steam-driven ships. Provision for

Status: This is the original version (as it was originally enacted).

- the supply of smothering gas or steam need not be required in ships of less than 1,000 tons gross.
- 5 A sufficient number of portable fluid fire extinguishers shall be provided, at least two being carried in each machinery space.
- 6 Two equipments, consisting of a smoke helmet or breathing apparatus and a safety lamp, shall be carried on board, and kept in two widely separated places.
- 7 In steamships in which the main boilers are oil fired, there shall be provided in addition to means whereby two powerful jets of water may be rapidly and simultaneously directed into any part of the machinery spaces—
- (a) Suitable conductors for spraying water on oil without undue disturbance of the surface.
 - (b) In each firing space, a receptacle containing 283 cubic decimetres (10 cubic feet) of sand, sawdust impregnated with soda, or other approved dry materials, and scoops for distributing the same.
 - (c) In each boiler room, and in each of the machinery spaces in which a part of the oil fuel installation is situated, two approved portable extinguishers of a type discharging froth or other approved medium suitable for quenching oil fires.
 - (d) Means whereby froth may be rapidly discharged and distributed over the whole of the lower part of the boiler room or of any one boiler room, if there are more than one, or of any machinery space in which oil fuel units or settling tanks are situated. The quantity of froth which can be discharged shall be ample to cover to a depth of 15.24 centimetres (6 inches) the whole area of the plating formed in any one compartment by the inner bottom plating, or by the shell plating of the vessel, if there is no double-bottom tank. If the engine and boiler rooms are not entirely separate, and fuel can drain from the boiler room bilges into the engine room, the combined engine and boiler rooms shall be considered as one compartment. The apparatus shall be operated and controlled from outside the compartment in which the fire may occur.
 - (e) In addition to the foregoing, one extinguisher of the froth type of at least 136 litres (30 gallons) capacity in steamships having one boiler room and two such extinguishers in steamships with more than one boiler room. These extinguishers shall be provided with hoses on reels suitable for reaching any part of the boiler rooms and spaces containing oil-fuel pumping units. Equally efficient apparatus may be accepted in place of the 136 litres (30-gallons) extinguishers.
 - (f) All containers and valves by which they are operated shall be easily accessible and so placed that they will not readily be cut off from use by an outbreak of fire.
- (8) In vessels propelled by internal combustion engines there shall be provided in each of the machinery spaces, in addition to means whereby two powerful jets of water may be rapidly and simultaneously directed into any part of the machinery spaces, together with suitable spraying conductors, froth extinguishers as follows :—
- (a) At least one approved 45 litres (10-gallons) extinguisher with an addition of one approved 9 litres (2-gallons) extinguisher for each 1,000 B.H.P. of the engines, but the total number of 9 litres (2-gallons) extinguishers so supplied shall be not less than two and need not exceed six.

Status: This is the original version (as it was originally enacted).

- (b) When a donkey boiler is situated in the machinery space there shall be provided, in place of the 45 litres (10-gallons) extinguisher mentioned above, one of 136 litres (30 gallons) capacity, fitted with suitable hose attachments or other approved methods for distributing the froth.
- (9) In steamships using oil fuel, if the engine and boiler rooms are not entirely separated by a steel bulkhead, and if fuel oil can drain from the boiler-room bilges into the engine room, one of the fire pumps shall be situated in the tunnel or other space outside the machinery compartment. When more than two pumps are required they shall not all be fitted in the same space.
- (10) Where any special type of appliance, extinguishing medium or arrangement is specified, any other type of appliance, &c, may be allowed, provided that it is not less effective than the specified one. For example—a Carbon Dioxide system may be accepted in place of a froth installation (paragraph (7), sub-paragraphs (d) and (e)), provided that the quantity of carbon dioxide carried is sufficient to give a gas saturation of about 25 per cent. for the gross volume of the stokehold to about the top of the boilers.
- (11) All the fire-extinguishing appliances shall be thoroughly examined at least once each year by a surveyor appointed by the Administration.

REGULATION XLIV

Muster List.

The muster list shall assign duties to the different members of the crew in connexion with—

- (a) The closing of the watertight doors, valves, &c.
- (b) The equipment of the boats, life rafts and buoyant apparatus generally.
- (c) The launching of the boats attached to davits.
- (d) The general preparation of the other boats, the life rafts and buoyant apparatus.
- (e) The muster of the passengers.
- (f) The extinction of fire.

The muster list shall assign to the members of the stewards' department their several duties in relation to the passengers at a time of emergency. These duties shall include :—

- (a) Warning the passengers.
- (b) Seeing that they are dressed and have put on their life-jackets in a proper manner.
- (c) Assembling the passengers at muster stations.
- (d) Keeping order in the passages and on the stairways, and, generally, controlling the movements of the passengers.

The muster list shall specify definite signals for calling all the crew to their boat and fire stations, and shall give full particulars of these signals.

REGULATION XLV

Musters and Drills.

Musters of the crew for boat drill shall take place weekly when practicable, and in vessels in which the voyage exceeds one week, before leaving port. The dates upon which musters are held shall be recorded in the Official Log Book and, if in any week a muster is not held, an entry shall be made stating why a muster was not practicable.

Status: This is the original version (as it was originally enacted).

In ships in which the voyage exceeds one week practice musters of passengers should be held at an early period of each voyage.

Different groups of boats shall be used in turn at successive boat drills. The drills and inspections shall be so arranged that the crew thoroughly understand and are practised in the duties they have to perform, and that all lifesaving appliances with the gear appertaining to them are always ready for immediate use.

The emergency signal for summoning passengers to muster stations shall be a succession of more than six short blasts followed by one long blast on the whistle or syren. This shall be supplemented on all ships except those engaged in short international voyages by other electrically operated signals throughout the ship controlled from the bridge. The meaning of all signals affecting passengers shall be clearly stated in different languages on cards posted in their cabins and in other passenger quarters.

SAFETY OF NAVIGATION.

REGULATION XLVI

Transmission of Information.

The transmission of information regarding ice, derelicts, tropical storms or any other direct danger to navigation is obligatory. The form in which the information is sent is not obligatory. It may be transmitted either in plain language (preferably English) or by means of the International Code of Signals (Wireless Telegraphy Section). It should be issued CQ to all ships, and should also be sent to the first point of the coast to which communication can be made with a request that it be transmitted to the appropriate authority.

All messages issued under Article 34 of the present Convention will be preceded by the safety signal TTT followed by an indication of the nature of the danger, thus : TTT Ice; TTT Derelict; TTT Storm; TTT Navigation.

Information Required.

The following information is desired, the time in all cases being Greenwich Mean Time :—

- (a) *Ice, Derelicts and other Direct Dangers to Navigation.*
 - (1) the kind of ice, derelict or danger observed;
 - (2) the position of the ice, derelict or danger when last observed.
 - (3) the time and date when the observation was made.
- (b) *Tropical Storms.*—(Hurricanes in the West Indies, Typhoons in the China Seas, Cyclones in Indian waters, and storms of a similar nature in other regions.)
 - (1) *A Statement that a Tropical Storm has been Encountered.*—This obligation should be interpreted in a broad spirit, and information transmitted whenever the master has good reason to believe that a tropical storm exists in his neighbourhood.
 - (2) *Meteorological Information.*—In view of the great assistance given by accurate meteorological data in fixing the position and movement of storm centres, each shipmaster should add to his warning message as much of the following meteorological information as he finds practicable:—
 - (a) barometric pressure (millibars, inches or millimetres) ;
 - (b) change in barometric pressure (the change during the previous two to four hours);
 - (c) wind direction (true not magnetic);
 - (d) wind force (Beaufort or decimal scale);

Status: This is the original version (as it was originally enacted).

- (e) state of the sea (smooth, moderate, rough, high) ;
- (f) swell (slight, medium, heavy) and the direction from which it comes.

When barometric pressure is given the word " millibars, " " inches " or " millimetres, " as the case may be, should be added to the reading, and *it should always be stated whether the reading is corrected or uncorrected.*

When changes of the barometer are reported the course and speed of the ship should also be given.

All directions should be true, not magnetic.

- (3) *Time and Date and Position of the Ship.*—These should be for the time and position when the meteorological observations reported were made and not when the message was prepared or despatched. The time used in all cases should be Greenwich Mean Time.
- (4) *Subsequent Observations.*—When a master has reported a tropical storm it is desirable, but not obligatory, that other observations be made and transmitted at intervals of three hours, so long as the ship remains under the influence of the storm.

Examples.

Ice.

TTT Ice. Large berg sighted in 4605 N., 4410 W., at 0800 GMT. May 15.

Derelict.

TTT Derelict. Observed derelict almost submerged in 4006 N., 1243 W., at 1630 GMT. April 21.

Danger to Navigation.

TTT Navigation. Alpha lightship not on station. 1800 GMT. January 3.

Tropical Storm.

TTT Storm. Experiencing tropical storm. Barometer corrected 994 millibars, falling rapidly. Wind NW., force 9, heavy squalls. Swell E. Course ENE., 5 knots. 2204 N., 11354 E. 0030 GMT. August 18.

TTT Storm. Appearances indicate approach of hurricane. Barometer corrected 29.64 inches falling. Wind NE., force 8. Swell medium from NE. Frequent rain squalls. Course 35°, 9 knots. 2200 N., 7236 W. 1300 GMT. September 14.

TTT Storm. Conditions indicate intense cyclone has formed. Wind S. by W. force 5. Barometer uncorrected 753 millimetres, fell 5 millimetres last three hours. Course N. 60 W., 8 knots. 1620 N., 9302 E. 0200 GMT. May 4.

TTT Storm. Typhoon to south-east. Wind increasing from N. and barometer falling rapidly. Position 1812 N., 12605 E. 0300 GMT. June 12.

CERTIFICATES.

REGULATION XLVII

Form of Safety Certificate for Passenger Ships.
SAFETY CERTIFICATE.

Status: This is the original version (as it was originally enacted).

(Official Seal.)

(Country.)

**Issued under the provisions of the
INTERNATIONAL CONVENTION FOR SAFETY OF LIFE AT SEA, 1929.**

Name of Ship.	Distinctive Number or Letters.	Port of Registry.	Gross Tonnage.

The _____ *(Name)* Government certify
I, the undersigned, _____ *(Name)* certify

That the above-mentioned ship complies with the provisions of the International Convention referred to above as regards Radiotelegraphy :—

—	Requirements of Articles.....of the said Convention.	Actual provision.
Hours of watch - - -
Whether approved auto-alarm fitted - - -
Whether separate emergency installation fitted - - -
Minimum number of operators -
Additional operators or watchers
Whether direction-finding apparatus fitted - - -

This certificate is issued under the authority of the Government. It will remain in force until

Issued at _____ the _____ day of _____

Here follows the seal or signature of the authority entitled to issue this certificate.

(Seal.)

If signed, the following paragraph is to be added :—

The undersigned declares that he is duly authorised by the said Government to issue this certificate.

(Signature.)

Form of Exemption Certificate.
EXEMPTION CERTIFICATE.

ANNEX II

INTERNATIONAL REGULATIONS FOR PREVENTING COLLISIONS AT SEA.

FINAL ACT OF THE INTERNATIONAL CONFERENCE ON SAFETY OF LIFE AT SEA.

I

International Regulations for preventing Collisions at Sea Final Act of the International Conference on Safety of Life at Sea I. At the moment of signing the Convention for the Safety of Life at Sea concluded this day, the undersigned Plenipotentiaries have agreed on the following:—

SAFETY OPERATORS.

In order to ensure the coming into force at an early date of the international agreement to make the installation of radio-telegraphy obligatory on all cargo ships of 1,600 tons gross tonnage and upwards, and thereby to promote the general safety of life at sea, the Contracting Governments undertake to use their efforts to promote an amendment to the Radiotelegraph Convention to the effect that the requirements as to the minimum speed of operation to be attained by an operator on board a compulsorily fitted ship should be laid down as follows:—

“Correct transmission and correct reception by ear of code groups (mixed letters, figures and punctuation marks) at a speed of 16 (sixteen) groups per minute. Each code group must comprise 5 (five) characters, each figure or punctuation mark counting as 2 (two) characters.”

Should the International Radiotelegraph Conference find itself unable to approve of the above proposal, the present Conference is of opinion that a new Certificate with operating qualifications as set out above should be established, and that the holders of such Certificate should be authorised to deal with public correspondence in ship stations of the Third Class as defined by the Washington Radiotelegraph Convention.

II

The Conference takes note of the following declarations, made by the undermentioned delegations :—

(A.)

The Plenipotentiaries of the United States of America formally declare that the signing of the International Convention for the Safety of Life at Sea by them, on the part of the United States of America, on this date, is not to be construed to mean that the Government of the United States of America recognizes a regime or entity which signs or accedes to the Convention as the Government of a country when that regime or entity is not recognized by the Government of the United States of America as the Government of that country.

The Plenipotentiaries of the United States of America further declare that the participation of the United States of America in the International Convention for the Safety of Life at Sea signed on this date does not involve any contractual obligation on the part of the United States of America to a country, represented by a regime or entity which the Government of the United

Status: This is the original version (as it was originally enacted).

States of America does not recognize as the Government of that country, until such country has a Government recognized by the Government of the United States of America.

(B.)

The Delegation of the Union of Socialist Soviet Republics declares that the Government of the Union of Socialist Soviet Republics, not being a party to the International Radiotelegraph Convention of 1927, does not consider itself bound by the undertaking embodied in Part I of this Final Act, but will, upon ratification of the International Convention for the Safety of Life at Sea, apply and give full effect to those articles of the last-named Convention and its annexes, where reference is made to provisions of the said Radiotelegraph Convention, as parties to the International Convention for the Safety of Life at Sea only.

III

The Conference also adopts the following recommendations :—

AS REGARDS CONSTRUCTION.

1. Stability.

The necessity for and practicability of adopting stability regulations have been considered by this Conference, and the opinion has been reached that at this time it is practicable to adopt only the general requirement for stability tests on new passenger ships contained in Article 8. The Conference desires, however, to draw the attention of the Contracting Governments to the desirability of a study by each Administration of the subject of stability for the different national types of ships and trades, and of the exchange of information on this subject between these Contracting Governments.

2. Openings in Bulkheads and Ship's Sides.

The objection which attaches to openings, which may sometimes be open at sea, in the sides of ships and in the main transverse watertight bulkheads is recognised by this Conference, but it is the sense of the Conference that it is not at this time practicable to adopt international regulations concerning such openings which are more exacting than those incorporated in the Regulations. The Conference recommends, however, that the various Governments make special effort to assure that the number of such openings, particularly hinged sidescuttles below the margin line and doors low down in the machinery space bulkheads, be kept at the minimum required in each case.

3. Services of Special Risk.

The International Conference on Safety of Life at Sea realises that there are trades, such as the passenger services between England and the nearby Continental ports, in which the sea risks are, owing to weather and traffic conditions, exceptional, and where it is practicable, owing to the absence of general cargo, to adopt a higher standard of subdivision than that prescribed by the Convention. The Conference, therefore, recommends that the Contracting Governments concerned consider the adoption, in the case of ships primarily engaged in the carriage of passengers in such trades, of such improved standards of subdivision as may be found reasonable and practicable.

Status: This is the original version (as it was originally enacted).

AS REGARDS LIFE-SAVING APPLIANCES, &C.

4. Means of Clinging to Boats.

The International Conference on Safety of Life at Sea recommends that the Contracting Governments should consider the practicability of requiring lifeboats carried on ships registered in their ports to be fitted with means to enable persons to cling to the boats if upturned in the water, without increasing the risks incident to the lowering of the boats.

5. Dangerous Goods.

The International Conference on Safety of Life at Sea recommends that every possible effort should be made with a view to attaining an international agreement as to what goods should be considered as "dangerous goods" as mentioned in Article 24 of the Present Convention and of fixing uniform rules for the packing and stowage of such goods.

AS REGARDS RADIOTELEGRAPHY

6. Alarm Signal.

The International Conference on Safety of Life at Sea, having approved of the use of the automatic alarm receiver for watch-keeping purposes, and anticipating that a large number of these receivers will be installed in passenger and cargo ships in the near future, recommends that the next International Radiotelegraph Conference prescribe that " the alarm signal shall, as a general rule, precede the distress signal."

7. Cyclone Warnings.

The International Conference on Safety of Life at Sea, considering that it is of more importance to prevent disaster than to render assistance after a disaster has occurred, and being of the opinion that in certain cases use may be made of the auto-alarm to this end, strongly recommends that the next International Radiotelegraph Conference authorise Governments to permit coast stations under their jurisdiction to precede the broadcasting of emergency cyclone warnings by the alarm signal.

8. Wave Lengths.

The International Conference on Safety of Life at Sea draws the attention of the Governments concerned to the advisability of ensuring that signals of distress utilising waves of Type A 2 shall be effective over a sufficiently wide band of frequencies.

The Conference also desires to draw attention to the provisions of Article 5, § 11, of the Regulations annexed to the International Radiotelegraph Convention, Washington, 1927, and to point out that radiotelephonic transmissions on frequencies in the neighbourhood of the distress wave will render inoperative automatic alarm receivers working on the alarm signal denned in Article 19, § 21 (e), of the above-mentioned Regulations. The Conference desires, therefore, to emphasise the importance, in the interests of safety of life at sea, of avoiding the use of radiotelephonic emissions in the neighbourhood of the distress wave, except in case of emergency.

Status: This is the original version (as it was originally enacted).

AS REGARDS SAFETY OF NAVIGATION.

9. Radio Aids to Navigation.

The International Conference on Safety of Life at Sea recommends that the Contracting Governments should establish and maintain an adequate system of radio aids to navigation, and should take all necessary measures to ensure the efficiency and reliability of such services.

10. Synchronised Radio and Under-Water Signals.

The International Conference on Safety of Life at Sea favours the extension of the installation of distance-finding apparatus capable of emitting synchronised radio and under-water signals, as necessary to meet navigational needs in distance-finding and position finding by vessels.

11. Depth-Sounding Apparatus.

The International Conference on Safety of Life at Sea recommends that the Contracting Governments should encourage the development and use of echo depth-sounding apparatus.

12. Life-Saving Signals.

The International Conference on Safety of Life at Sea considers that the signals for life-saving stations communicating with vessels in distress and signals for vessels in distress communicating with life-saving stations should be international

13. Shore Lights.

The International Conference on Safety of Life at Sea considers that, so far as practicable, steps should be taken by the Administrations concerned to regulate the position and the intensity of lights on land in the vicinity of the entrances to ports so as to ensure that such lights cannot be mistaken for, or do not impair the visibility of, the navigation lights of the port.

14. Collision Regulations,—Aircraft.

Under the International Collision Regulations, aircraft on the surface of the water are within the definition of " steam vessels." As such, they are required to carry lights, make sound signals and manoeuvre, both in respect of surface vessels and of each other, in a manner that is not, in some instances, possible for them, due to the physical limitations of aircraft. At the same time, they can and should take upon themselves some definite measure of responsibility for the avoidance of collisions between surface vessels and aircraft on the surface of the water, and it is necessary that their rights and duties, when on the surface of the water, should be defined.

In order that an international agreement may be reached covering those provisions of the International Collision Regulations which apply to surface vessels and to aircraft on the surface of the high seas and on the waters connected therewith, navigable by sea-going vessels, the Conference recommends, in the interests of safety of life at sea, that this question should be studied by the competent authorities in the countries concerned, so that there may be an exchange of views, and an endeavour made to arrive at an international agreement. The Conference requests the Government of the United Kingdom of Great Britain and Northern Ireland to take the necessary action in the matter.

Status: This is the original version (as it was originally enacted).

AS REGARDS CERTIFICATES.

15. Recognition of Convention Standards.

Recognising the importance of bringing the Convention standards into operation at the earliest possible date, it is recommended that all such steps as may be practicable should be taken by the Contracting Governments to secure the recognition in international trade as from the date of the signing of this Convention of such ships as in fact conform to such standards.

In faith whereof the undersigned have affixed their signatures to the present Act.

Done in London this thirty-first day of May, 1929, in a single copy which shall be deposited in the archives of the Government of the United Kingdom of Great Britain and Northern Ireland, which shall transmit certified true copies thereof to all signatory Governments.

SECOND SCHEDULE

INTERNATIONAL CONVENTION RESPECTING LOAD LINES, 1930.

CHAPTER I

PRELIMINARY.

ARTICLE 1.

General Obligation of Convention.

So that the load lines prescribed by this Convention shall be observed, the Contracting Governments undertake to give effect to the provisions of this Convention, to promulgate all regulations, and to take all other steps which may be necessary to give this Convention full and complete effect.

The provisions of this Convention are completed by Annexes, which have the same force and take effect at the same time as this Convention. Every reference to this Convention implies at the same time a reference to the Rules annexed thereto.

ARTICLE 2

Scope of Convention.

- 1 This Convention applies to all ships engaged on international voyages, which belong to countries the Governments of which are Contracting Governments, or to territories to which this Convention is applied under Article 21, except—
 - (a) ships of war; ships solely engaged in fishing; pleasure yachts and ships not carrying cargo or passengers;
 - (b) ships of less than 150 tons gross.
- 2 Ships when engaged on international voyages between the near neighbouring ports of two or more countries may be exempted by the Administration to which such ships belong from the provisions of this Convention, so long as they shall remain in such trades, if the Governments of the countries in which such ports are situated shall be satisfied that the sheltered nature and conditions of such voyages between

Status: This is the original version (as it was originally enacted).

such ports make it unreasonable or impracticable to apply the provisions of this Convention to ships engaged in such trades.

- 3 All agreements and arrangements relating to load line or matters appertaining thereto at present in force between Contracting Governments shall continue to have full and complete effect during the terms thereof as regards—
- (a) ships to which this Convention does not apply;
 - (b) ships to which this Convention applies in respect of matters for which it has not expressly provided.

To the extent, however, that such agreements or arrangements conflict with the provisions of this Convention, the provisions of this Convention shall prevail.

Subject to any such agreement or arrangement—

- (a) all ships to which this Convention does not apply; and
 - (b) all matters which are not expressly provided for in this Convention;
- shall remain subject to the legislation of each Contracting Government to the same extent as if this Convention had not been made.

ARTICLE 3

Definitions.

In this Convention, unless expressly provided otherwise—

- (a) a ship is regarded as belonging to a country if it is registered by the Government of that country;
- (b) the expression " Administration " means the Government of the country to which the ship belongs;
- (c) an " international voyage " is a voyage from a country to which this Convention applies to a port outside such country, or conversely, and for this purpose, every colony, overseas territory, protectorate or territory under suzerainty or mandate is regarded as a separate country;
- (d) the expression " Rules " means the Rules contained in Annexes I, II and III;
- (e) a " new ship " is a ship, the keel of which is laid on or after the 1st July, 1932, all other ships being regarded as existing ships;
- (f) the expression " steamer " includes any vessel propelled by machinery.

ARTICLE 4

Cases of " Force Majeure. "

No ship, which is not subject to the provisions of this Convention at the time of its departure on any voyage, shall become subject to the provisions of this Convention on account of any deviation from its intended voyage due to stress of weather or any other cause of *force majeure*.

In applying the provisions of this Convention, the Administration shall give due consideration to any deviation or delay caused to any ship owing to stress of weather or to any other cause of *force majeure*.

Status: This is the original version (as it was originally enacted).

CHAPTER II

LOAD LINE : SURVEY AND MARKING.

ARTICLE 5.

General Provisions.

No ship to which this Convention applies shall proceed to sea on an international voyage after the date on which this Convention comes into force, unless the ship, being—

- A —a new ship,
 - (a) has been surveyed in accordance with the provisions of Annex I;
 - (b) complies with the provisions of Part II of Annex I; and
 - (c) has been marked in accordance with the provisions of this Convention.
- B —an existing ship,
 - (a) has been surveyed and marked (whether before or after this Convention comes into force) in accordance with the conditions prescribed either in paragraph A of this Article or in one of the sets of Rules for the Assignment of Load Line particularised in Annex IV; and
 - (b) complies with the provisions of Part II of Annex I in principle, and also in detail, so far as is reasonable and practicable, having regard to the efficiency of (i) the protection of openings; (ii) guard rails; (iii) freeing ports, and (iv) means of access to crews' quarters provided by the existing arrangements, fittings and appliances on the ship.

ARTICLE 6

Provisions for Steamers carrying Timber Deck Cargoes.

- 1 A steamer which has been surveyed and marked under Article 5 shall be entitled to be surveyed and marked with a timber load line under Part V of Annex I if, being—
 - A —a new ship, it complies with the conditions and provisions prescribed in Part V of Annex I;
 - B —an existing ship, it complies with the conditions and provisions of Part V of Annex I other than Rule LXXX, and also in principle, so far as is reasonable and practicable, with the conditions and provisions prescribed by Rule LXXX. provided that in assigning a timber load line to an existing ship the Administration shall make such addition to the freeboard as shall be reasonable, having regard to the extent to which such ship falls short of full compliance with the conditions and provisions prescribed in Rule LXXX.
- 2 A steamer when using the timber load line shall comply with Rules LXXXIV, LXXXV, LXXXVI, LXXXVLU and LXXXIX.

ARTICLE 7

Provisions for Tankers.

A steamer which has been surveyed under Article 5 shall be entitled to be surveyed and marked as a tanker under Part VI of Annex I if, being—

- A —a new ship, it complies with the conditions and provisions prescribed in Part VI of Annex I;

Status: This is the original version (as it was originally enacted).

B —an existing ship, it complies with the conditions and provisions in Rules XCIH, XCVI, XCVH, XCVIII and XCIX, and also in principle so far as is reasonable and practicable with Rules XCIV, XCV and C, provided that in assigning a tanker load line to an existing ship the Administration shall make such addition to the free-board as shall be reasonable having regard to the extent to which such ship falls short of full compliance with the conditions and provisions prescribed in Rules XCIV, XCV and C.

ARTICLE 8

Provisions for Ships of Special Types.

For steamers over 300 feet in length, possessing constructional features similar to those of a tanker which afford extra invulnerability against the sea, a reduction in freeboard may be granted.

The amount of such reduction shall be determined by the Administration in relation to the freeboard assigned to tankers, having regard to the degree of compliance with the conditions of assignment laid down for these ships, and the degree of subdivision provided.

The freeboard assigned to such a ship shall in no case be less than would be assigned to the ship as a tanker.

ARTICLE 9

Survey.

The survey and marking of ships for the purpose of this Convention shall be carried out by officers of the country to which the ships belong, provided that the Government of each country may entrust the survey and marking of its ships either to Surveyors nominated for this purpose, or to organisations recognised by it. In every case the Government concerned fully guarantees the completeness and efficiency of the survey and marking.

ARTICLE 10

Zones and Seasonal Areas.

A ship to which this Convention applies shall conform to the conditions applicable to the zones and seasonal areas described in Annex II to this Convention.

A port standing on the boundary line between two zones shall be regarded as within the zone from or into which the ship arrives or departs.

CHAPTER III

CERTIFICATES.

ARTICLE 11.

Issue of Certificates.

A certificate, called " International Load Line Certificate, " shall be issued to every ship which has been surveyed and marked in accordance with this Convention, but not otherwise.

Status: This is the original version (as it was originally enacted).

An International Load Line Certificate shall be issued either by the Government of the country to which the ship belongs or by any person or organisation duly authorised by that Government, and in every case the Government assumes full responsibility for the certificate.

ARTICLE 12

Issue of Certificates by another Government.

The Government of a country to which this Convention applies may, at the request of the Government of any other country to which this Convention applies, cause any ship which belongs to the last-mentioned country, or (in the case of an unregistered ship) which is to be registered by the Government of that country, to be surveyed and marked, and, if satisfied that the requirements of this Convention are complied with, issue an international Load Line Certificate to such ship, under its own responsibility. Any certificate so issued must contain a statement to the effect that it has been issued at the request of the Government of the country to which the ship belongs, or of the Government by whom the ship is to be registered, as the case may be, and it shall have the same force and receive the same recognition as a certificate issued under Article 11 of this Convention.

ARTICLE 13

Form of Certificate.

The International Load Line Certificates shall be drawn up in the official language or languages of the country by which they are issued.

The form of the certificate shall be that of the model given in Annex III, subject to such modifications as may, in accordance with Rule L)(VIII), be made in the case of ships carrying timber deck cargoes.

ARTICLE 14

Duration of Certificates.

- 1 An International Load Line Certificate shall, unless it is renewed in accordance with the provisions of paragraph 2 of this Article, expire at the end of such period as may be specified therein by the Administration which issues it: but the period so specified shall not exceed five years from the date of issue.
- 2 An International Load Line Certificate may be renewed from time to time by the Administration which issued it for such period (not exceeding five years on any occasion) as the Administration thinks fit, after a survey not less effective than the survey required by this Convention before the issue of the certificate, and any such renewal shall be endorsed on the certificate.
- 3 An Administration shall cancel any International Load Line Certificate issued to a ship belonging to its country :
 - A. If material alterations have taken place in the hull and superstructures of the ship which affect the calculations of freeboard.
 - B. If the fittings and appliances for the (i) protection of openings, (ii) guard rails, (iii) freeing ports and (iv) means of access to crews' quarters are not maintained in as effective a condition as they were in when the certificate was issued.
 - C. If the ship is not inspected periodically at such times and under such conditions as the Administration may think necessary for the purpose of securing that the hull and superstructures referred to in Condition A are not altered and that the

Status: This is the original version (as it was originally enacted).

fittings and appliances referred to in Condition B are maintained as therein provided throughout the duration of the certificate.

ARTICLE 15

Acceptance of Certificates.

International Load Line Certificates issued under the authority of a Contracting Government shall be accepted by the other Contracting Governments as having the same force as the certificates issued by them to ships belonging to their respective countries.

ARTICLE 16

Control.

- 1 A ship to which this Convention applies, when in a port of a country to which it does not belong, is in any case subject to control with respect to load line as follows: An officer duly authorised by the Government of that country may take such steps as may be necessary for the purpose of seeing that there is on board a valid International Load Line Certificate. If there is such a certificate on board the ship, such control shall be limited to the purpose of securing—
 - (a) that the ship is not loaded beyond the limits allowed by the certificate;
 - (b) that the position of the load line on the ship corresponds with the certificate; and
 - (c) that the ship has not been so materially altered in respect to the matters dealt with in conditions A and B (set out in paragraph 3 of Article 14) that the ship is manifestly unfit to proceed to sea without danger to human life.
- 2 Only officers possessing the necessary technical qualifications shall be authorised to exercise control as aforesaid, and if such control is exercised under (c) above, it shall only be exercised in so far as may be necessary to secure that the ship shall be made fit to proceed to sea without danger to human life.
- 3 If control under this Article appears likely to result in legal proceedings being taken against the ship, or in the ship being detained, the consul of the country to which the ship belongs shall be informed as soon as possible of the circumstances of the case.

ARTICLE 17

Privileges.

The privileges of this Convention may not be claimed in favour of any ship unless it holds a valid International Load Line Certificate.

CHAPTER IV

GENERAL PROVISIONS.

ARTICLE 18.

Equivalents.

Where in this Convention it is provided that a particular fitting, or appliance, or type thereof, shall be fitted or carried in a ship, or that any particular arrangement shall be adopted,

Status: This is the original version (as it was originally enacted).

any Administration may accept in substitution therefor any other fitting, or appliance, or type thereof, or any other arrangement, provided that such Administration shall have been satisfied that the fitting, or appliance, or type thereof, or the arrangement substituted is in the circumstances at least as effective as that specified in this Convention.

Any Administration which so accepts a new fitting, or appliance, or type thereof, or new arrangement shall communicate the fact to the other Administrations, and, upon request, the particulars thereof.

ARTICLE 19

Laws, Regulations, Reports.

The Contracting Governments undertake to communicate to each other—

- (1) the text of laws, decrees, regulations and decisions of general application which shall have been promulgated on the various matters within the scope of this Convention;
- (2) all available official reports or official summaries of reports in so far as they show the results of the provisions of this Convention, provided always that such reports or summaries are not of a confidential nature.

The Government of the United Kingdom of Great Britain and Northern Ireland is invited to serve as an intermediary for collecting all this information and for bringing it to the knowledge of the other Contracting Governments.

ARTICLE 20

Modifications, Future Conferences.

1 Modifications of this Convention which may be deemed useful or necessary improvements may at any time be proposed by any Contracting Government to the Government of the United Kingdom of Great Britain and Northern Ireland, and such proposals shall be communicated by the latter to all the other Contracting Governments, and if any such modifications are accepted by all the Contracting Governments (including Governments which have deposited ratifications or accessions which have not yet become effective) this Convention shall be modified accordingly.

2 Conferences for the purpose of revising this Convention shall be held at such times and places as may be agreed upon by the Contracting Governments.

A Conference for this purpose shall be convoked by the Government of the United Kingdom of Great Britain and Northern Ireland whenever, after this Convention has been in force for five years, one-third of the Contracting Governments express a desire to that effect.

CHAPTER V

FINAL PROVISIONS.

ARTICLE 21.

Application to Colonies.

- 1 A Contracting Government may, at the time of signature, ratification, accession or thereafter, by a notification in writing addressed to the Government of the United Kingdom of Great Britain and Northern Ireland, declare its desire that this Convention shall apply to all or any of its Colonies, overseas territories, protectorates or territories under suzerainty or mandate, and this Convention shall apply to all the territories named in such notification, two months after the date of the receipt thereof, but, failing such notification, this Convention will not apply to any such territories.
- 2 A Contracting Government may at any time by a notification in writing addressed to the Government of the United Kingdom of Great Britain and Northern Ireland express its desire that this Convention shall cease to apply to all or any of its colonies, overseas territories, protectorates or territories under suzerainty or mandate to which this Convention shall have, under the provisions of the preceding paragraph, been applicable for a period of not less than five years, and in such case the Convention shall cease to apply twelve months after the date of the receipt of such notification by the Government of the United Kingdom A.D. 1932 of Great Britain and Northern Ireland to all territories mentioned—therein.
- 3 The Government of the United Kingdom of Great Britain and Northern Ireland shall inform all the other Contracting Governments of the application of this Convention to any Colony, overseas territory, protectorate or territory under suzerainty or mandate under the provisions of paragraph 1 of this Article, and of the cessation of any such application under the provisions of paragraph 2, stating in each case the date from which this Convention has become or will cease to be applicable.

ARTICLE 22

Authentic Texts.—Ratification.

This Convention, of which both the English and French texts shall be authentic, shall be ratified.

The instruments of ratification shall be deposited in the archives of the Government of the United Kingdom of Great Britain and Northern Ireland, which will notify all the other signatory or acceding Governments of all ratifications deposited and the date of their deposit.

ARTICLE 23

Accession.

A Government (other than the Government of a territory to which Article 21 applies) on behalf of which this Convention has not been signed, shall be allowed to accede thereto at any time after the Convention has come into force. Accessions shall be effected by means of notifications in writing addressed to the Government of the United Kingdom of Great Britain and Northern Ireland, and shall take effect three months after their receipt.

The Government of the United Kingdom of Great Britain and Northern Ireland shall inform all signatory and acceding Governments of all accessions received and of the date of their receipt.

Status: This is the original version (as it was originally enacted).

ARTICLE 24

Date of Coming in Force.

This Convention shall come into force on the 1st July, 1932, as between the Governments which have deposited their ratifications by that date, and provided that at least five ratifications have been deposited with the Government of the United Kingdom of Great Britain and Northern Ireland. Should five ratifications not have been deposited by that date, this Convention shall come into force three months after the date on which the fifth ratification is deposited. Ratifications deposited after the date on which this Convention has come into force shall take effect three months after the date of their deposit.

ARTICLE 25

Denunciation.

This Convention may be denounced on behalf of any Contracting Government at any time after the expiration of five years from the date on which the Convention comes into force in so far as that Government is concerned. Denunciation shall be effected by a notification in writing addressed to the Government of the United Kingdom of Great Britain and Northern Ireland, which will notify all the other contracting Governments of all denunciations received and of the date of their receipt.

A denunciation shall take effect twelve months after the date on which notification thereof is received by the Government of the United Kingdom of Great Britain and Northern Ireland.

FINAL PROTOCOL.

At the moment of signing the International Load Line Convention concluded this day, the under-mentioned Plenipotentiaries have agreed on the following :—

I

Ships engaged solely on voyages on the Great Lakes of North America and ships engaged in other inland waters are to be regarded as outside the scope of the Convention.

II

This Convention is not applied to the existing ships of the United States of America and of France of the lumber schooner type propelled by power, with or without sails, or by sails alone.

III

The Government of the United Kingdom of Great Britain and Northern Ireland shall convoke a Conference of the Contracting Governments of the countries to which tankers belong, upon request of the United States of America, at any time within the five-year period mentioned in Article 20, for the purpose of discussing matters relating to tanker freeboard.

The Contracting Governments will not raise any objection to the provisions contained in this Convention in regard to tanker load line being altered as may be determined at such Conference, provided that the conclusions then reached are communicated forthwith to the Governments signatory to the present Convention and that no objection is received by the Government of the United Kingdom of Great Britain and Northern Ireland within six months of the despatch of such communication.

Status: This is the original version (as it was originally enacted).

In witness whereof the Plenipotentiaries have drawn up this Final Protocol which shall have the same force and the same validity as if the provisions thereof had been inserted in the text of the Convention to which it belongs.

Done at London this fifth day of July, 1930, in a single copy which shall be deposited in the archives of the Government of the United Kingdom of Great Britain and Northern Ireland, which shall transmit certified true copies thereof to all signatory Governments.

Status: This is the original version (as it was originally enacted).

ANNEX I

Rules for determining Maximum Load Lines of Merchant Ships.

PART I

GENERAL.

The Rules necessarily assume that the nature and stowage of the cargo, ballast, &c, are such as to secure sufficient stability for the ship.

RULE I

Definitions.

Steamer.—The term " steamer " includes all ships having sufficient means for mechanical propulsion, except where provided with sufficient sail area for navigation under sails alone.

A ship fitted with mechanical means of propulsion and with sail area insufficient for navigation under sails alone may be assigned a load line under Part III of these Rules.

A lighter, barge or other ship without independent means of propulsion, when towed, is to be assigned a load line under Part III of these Rules.

Sailing Ship.—The term " sailing ship " includes all ships provided with sufficient sail area for navigation under sails alone, whether or not fitted with mechanical means of propulsion.

Flush Deck Ship.—A flush deck ship is one which has no superstructure on the freeboard deck.

Superstructure.—A superstructure is a decked structure on the freeboard deck extending from side to side of the ship. A raised quarter deck is considered a superstructure.

Freeboard.—The freeboard assigned is the distance measured vertically downwards at the (ride of the ship amidships from the upper edge of the deck line to the upper edge of the load line mark.

Freeboard Deck.—The freeboard deck is the deck from which the freeboard is measured, and is the uppermost complete deck having permanent means of closing all openings in weather portions of the deck in accordance with Rules VIII to)(VI. It is the upper deck in flush deck ships and ships with detached superstructures.

In ships having discontinuous freeboard decks within superstructures which are not intact, or which are not fitted with Class 1 closing appliances, the lowest line of the deck below the superstructure deck is taken as the freeboard deck.

Amidships.—Amidships is the middle of the length of the summer load water-line, as denned in Rule XXXII.

RULE II

Deck Line.

The deck line is a horizontal line twelve inches in length and one inch in breadth. It is to be marked amidships on each side of the ship, and its upper edge is to pass through the point where the continuation outwards of the upper surface of the freeboard deck intersects the outer surface

Status: This is the original version (as it was originally enacted).

of the shell. (See figure 1.) Where the deck is partly sheathed amidships, the upper edge of the deck line is to pass through the point where the continuation outwards of the upper surface of the actual sheathing at amidships intersects the outer surface of the shell.

RULE III

Load Line Disc.

The load line disc is twelve inches in diameter and is intersected by a horizontal line eighteen inches in length and one inch in breadth, the upper edge of which passes through the centre of the disc. The disc is to be marked amidships below the deck line.

RULE IV

Lines to be used in connection with the Disc.

The lines which indicate the maximum load line in different circumstances and in different seasons (*see* Annex II) are to be horizontal lines, nine inches in length and one inch in breadth, which extend from, and are at right angles to, a vertical line marked 21 inches forward of the centre of the disc (*see* figure 1).

The following are the lines to be used :—

Summer Load Line.—The Summer load line is indicated by the upper edge of the line which passes through the centre of the disc and also by a line marked S.

Winter Load Line.—The Winter load line is indicated by the upper edge of a line marked W.

Winter North Atlantic Load Line.—The Winter North Atlantic load line is indicated by the upper edge of a line marked WNA.

Tropical Load Line.—The Tropical Load Line is indicated by the upper edge of a line marked T.

Fresh Water Load Lines.—The Fresh Water load line in Summer is indicated by the upper edge of a line marked F. The difference between the Fresh Water load line in summer and the Summer load line is the allowance to be made for loading in Fresh Water at the other load lines. The Tropical Fresh Water load line is indicated by the upper edge of a line marked T.F.(2)

(2) Where sea-going steamers navigate a river or inland water, deeper loading is permitted corresponding to the weight of fuel, &c, required for consumption between the point of departure and the open sea.

Status: This is the original version (as it was originally enacted).

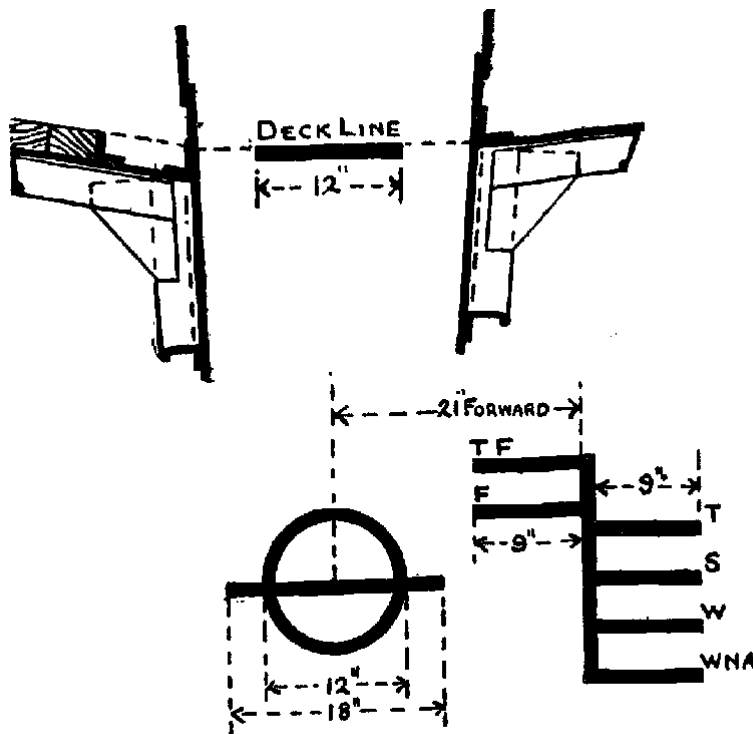

FIGURE 1.

RULE V

Mark of Assigning Authority.

The Authority by whom the load lines are assigned may be indicated by letters measuring about 4½ inches by 3 inches marked alongside the disc and above the centre line.

RULE VI

Details of Marking.

The disc, lines and letters are to be painted in white or yellow on a dark ground or in black on a light ground. They are also to be carefully cut in or centre-punched on the sides of iron and steel ships, and on wood ships they are to be cut into the planking for at least one-eighth of an inch. The marks are to be plainly visible, and, if necessary, special arrangements are to be made for this purpose.

RULE VII

Verification of Marks.

The International Load Line Certificate is not to be delivered to the ship until a surveyor of the Assigning Authority (acting under the provisions of Article 9 of this Convention) has certified that the marks are correctly and permanently indicated on the ship's sides.

PART II

CONDITIONS OF ASSIGNMENT OF LOAD LINES.

The assignment of load lines is conditional upon the ship being structurally efficient and upon the provision of effective protection to ship and crew.

Rules VIII to XXXI apply to ships to which minimum freeboards are assigned. In ships to which greater freeboards than the minimum are assigned, the protection is to be relatively as effective.

OPENINGS IN FREEBOARD AND SUPERSTRUCTURE DECKS.

RULE VIII

Cargo and other Hatchways not protected by Superstructures.

The construction and fitting of cargo and other hatchways in exposed positions on freeboard and superstructure decks are to be at least equivalent to the standards laid down in Rules IX to XVI.

RULE IX

Hatchway Coamings.

The height of hatchway coamings on freeboard decks is to be at least 24 inches above the deck. The height of coamings on superstructure decks is to be at least 24 inches above the deck if situated within a quarter of the ship's length from the stem, and at least 18 inches if situated elsewhere.

Coamings are to be of steel, are to be substantially constructed and, where required to be 24 inches high, are to be fitted with an efficient horizontal stiffener placed not lower than 10 inches below the upper edge, and fitted with efficient brackets or stays from the stiffener to the deck, at intervals of not more than 10 feet. Where end coamings are protected, these requirements may be modified.

RULE X

Hatchway Covers.

Covers to exposed hatchways are to be efficient, and where they are made of wood, the finished thickness is to be at least $2 \frac{3}{8}$ inches in association with a span of not more than 5 feet. The width of each bearing surface for these hatchway covers is to be at least $2 \frac{1}{2}$ inches.

RULE XI

Hatchway Beams and Fore-and-Afters.

Where wood hatchway covers are fitted the hatchway beams and fore-and-afters are to be of the scantlings and spacing given in Table 1 where coamings 24 inches high are required, and as given in Table 2 where coamings 18 inches high are required. Angle bar mountings on the upper edge are to extend continuously for the full length of each beam. Wood fore-and-afters are to be steel shod at all bearing surfaces.

Status: This is the original version (as it was originally enacted).

TABLE 1

(COAMINGS 24 INCHES IN HEIGHT.)

HATCHWAY Beams and Fore-and-Afters for Ships 200 feet or more in length.()

HATCHWAY BEAMS.

Breadth of Hatchway.	Mounting.			Beams with Fore-and-Afters.						Beams without Fore-and-Afters.			
				Spacing Centre to Centre.						Spacing Centre to Centre.			
	ins.	ins.	ins.	6' 0'		8' 0'		10' 0'		4' 0'		5' 0'	
	ins.	ins.	ins.	ins.	ins.	ins.	ins.	ins.	ins.	ins.	ins.	ins.	ins.
10' 0"	3 x	3 x	.40A	11 x	.30P	12 x	.32P	14 x	.34P	9 x	.46BP	10 x	.50BP
12' 0"	3 x	3 x	.40A	12 x	.32P	14 x	.34P	17 x	.36P	11 x	.50BP	12 x	.50BP
14' 0"	3 x	3 x	.42A	14 x	.34P	17 x	.36P	20 x	.38P	12 x	.50BP	12 x	.32P
16' 0"	3x	3 x	.42A	16 x	.36P	19 x	.38P	22 x	.38P	12 x	.32P	14 x	.34P
18' 0'	4 x	3 x	.44A	18 x	.36P	21 x	.38P	25 x	.40P	14 x	.34P	16 x	.36P
20' 0"	4 x	3 x	.44A	20 x	.38P	24 x	.40P	28 x	.42P	15 x	.34P	18 x	.36P
22' 0"	4 x	3 x	.46A	22 x	.38P	26 x	.42P	30 x	.44P	16 x	.36P	19 x	.36P
24' 0"	5 x	3 x	.46A	23 x	.40P	28 x	.42P	32 x	.44P	17 x	.36P	20 x	.38P
26' 0"	5 x	3 x	.48A	24 x	.40P	29 x	.42P	34 x	.46P	18 x	.36P	21 x	.38P
28' 0"	6 x	3 x	.50A	25 x	.40P	31 x	.44P	36 x	.48P	19 x	.38P	22 x	.38P
30' 0"	6 x	3 x	.52A	26 x	.42P	32 x	.44P	38 x	.48P	20 x	.38P	23 x	.40P

FORE-AND-AFTERS.

Length of Fore- and- Afters.	Mounting.			Bulb Plate. Centre Fore-and-Afters.						Bulb Angle. Side Fore-and-Afters.					
				Spacing Centre to Centre.						Spacing Centre to Centre.					
	ins.	ins.	ins.	3' 0"		4' 0"		5' 0"		3' 0"		4' 0"		5' 0"	
	ins.	ins.	ins.	ins.	ins.	ins.	ins.	ins.	ins.	ins.	ins.	ins.	ins.	ins.	ins.

Status: This is the original version (as it was originally enacted).

Length of Fore-and-Afters.	Mounting.			Bulb Plate. Centre Fore-and-Afters.						Bulb Angle. Side Fore-and-Afters.										
				Spacing Centre to Centre.						Spacing Centre to Centre.										
	3' 0"		4' 0"		5' 0"		3' 0"		4' 0"		5' 0"									
6' 0"	2 ½ x	2 ½ x	.36	6 x .36	6 ½ x .38	7 x .38	6 x 3 x .38	6 ½ x .38	3 ½ x .42	7 x 3 x .44	9 x 3 x .50	8 x 3 x .50	9 ½ x .50	11 x .50	8 x 3 x .38	6 ½ x .38	7 x 3 x .44	9 x 3 x .50		
8' 0"	2 ½ x	2 ½ x	.38	7 x .42	8 x .44	9 x .44	7 x 3 x .42	8 x 3 x .44	9 x 3 x .50	7 x 3 x .42	8 x 3 x .44	9 x 3 x .50	8 x 3 x .50	9 ½ x .50	11 x .50	8 x 3 x .38	6 ½ x .38	7 x 3 x .44	9 x 3 x .50	
10' 0"	2 ½ x	2 ½ x	.40	8 x .50	9 ½ x .50	11 x .50	8 x 3 x .50	9 ½ x .50	11 x .50	8 x 3 x .50	9 ½ x .50	11 x .50	8 x 3 x .50	9 ½ x .50	11 x .50	8 x 3 x .38	6 ½ x .38	7 x 3 x .44	9 x 3 x .50	
				Wood Centre Fore-and-Afters.						Wood Side Fore-and-Afters.										
				Spacing Centre to Centre.						Spacing Centre to Centre.										
				3' 0"		4' 0"		5' 0"		3' 0"		4' 0"		5' 0"						
				D	B	D	B	B	D	B	D	B	D	B	D	B				
				ins.	ins.	ins.	ins.	ins.	ins.	ins.	ins.	ins.	ins.	ins.	ins.	ins.				
6' 0"				5 ½	7	6	7	6 ½	7	5 ½	5 ½	6	6	6 ½	6					
8' 0"				6 ½	7	7 ½	7	8	7	6 ½	6 ½	7 ½	7	8	7					
10' 0"				8	7	8 ½	8	9	9	8	7	8 ½	8	9	9					

A = Plain angle. BP = Bulb plate. P = Plate. D = Depth. B = Breadth.

Depths for hatchway beams are at the middle of the length and are measured from the top mounting to the lower edge. Depths for fore-and-afters are measured from the under side of the hatch covers to the lower edge. Sizes for intermediate lengths and spacing are obtained by interpolation. Where plates are specified, two angles, of the size given for mountings, are to be fitted at the upper and at the lower part of the beam. Where bulb plates are specified, two angles, of the size given for mountings, are to be fitted at the upper part of the beam or fore-and-after. Where bulb angles are specified, one angle, of the size given for mountings, is to be fitted at the upper part of the section. Where the specified flanges of an angle are of different dimensions, the larger flange is to be horizontal.

* In ships not exceeding 100 feet in length, the depths of beams which are formed of plates and angles may be 60 per cent. of the depths given above; the depths of beams and steel fore-and-afters formed of bulb angle or bulb plate section may be 80 per cent. of the depths given above; the thickness of plates, bulb angles and bulb plates should correspond to the thickness tabulated for the reduced depths with a minimum thickness of .30 inch; the depths and breadths of wood fore-and-afters may be 80 per cent. of those given in the tables for side fore-and-afters, but the centre fore-and-afters must be not less than 6 ½ inches wide. In ships between 100 feet and 200 feet in length, the sizes of the beams and fore-and-afters are to be determined by linear interpolation.

TABLE 2

(COAMINGS 18 INCHES IN HEIGHT.)

HATCHWAY Beams and Fore-and-Afters for Ships 200 feet or more in length.()

Status: This is the original version (as it was originally enacted).

HATCHWAY BEAMS.

Breadth of Hatchway.	Mounting.			Beams with Fore-and-Afters.						Beams without Fore-and-Afters.			
				Spacing Centre to Centre.						Spacing Centre to Centre.			
	ins.	ins.	ins.	6' 0'		8' 0'		10' 0'		4' 0'		5' 0'	
	ins.	ins.	ins.	ins.	ins.	ins.	ins.	ins.	ins.	ins.	ins.	ins.	ins.
10' 0"	3 x	3 x	.40A	9 ½ x	.46BP	10 ½ x	.50BP	11 ½ x	.52BP	8 x	.40BP	9 x	.44BP
12' 0"	3 x	3 x	.40A	11 x	.50BP	11 x	.30P	13 x	.34P	9 x	.46BP	10 x	.50BP
14' 0"	3 x	3 x	.42A	11 x	.30P	13 x	.32P	15 x	.34P	10 x	.50BP	11 ½ x	.50BP
16' 0"	3 ½ x	3 x	.42A	12 x	.32P	15 x	.34P	17 x	.36P	11 x	.30P	11 x	.30P
18' 0"	4 x	3 x	.44A	14 x	.34P	17 x	.36P	19 x	.38P	11 x	.30P	12 x	.32P
20' 0"	4 x	3 x	.44A	16x	.36P	19 x	.38P	21 x	.38P	12 x	.32P	13 x	.34P
22' 0"	4 ½ x	3 x	.46A	17 x	.36P	20 x	.38P	23 x	.40P	12 ½ x	.32P	14 x	.34P
24' 0"	5 x	3 ½ x	.46A	18 x	.36P	21 x	.38P	25 x	.40P	13 x	.34P	14 ½ x	.34P
26' 0"	5 ½ x	3 ½ x	.48A	19 x	.38P	22 x	.38P	26 x	.42P	13 ½ x	.34P	15 x	.34P
28' 0"	6 x	3 ½ x	.50A	20 x	.38P	23 x	.40P	27 x	.42P	14 x	.34P	16 x	.36P
30' 0"	6 x	3 ½ x	.52A	21 x	.38P	24 x	.40P	28 x	.42P	15 x	.34P	17 x	.36P

FORE-AND-AFTERS.

Length of Fore-and-Afters.	Mounting.			Bulb Plate. Centre Fore-and-Afters.						Bulb Angle. Side Fore-and-Afters.								
				Spacing Centre to Centre.						Spacing Centre to Centre.								
	ins.	ins.	ins.	3' 0"		4' 0"		5' 0"		3' 0"			4' 0"			5' 0"		
	ins.	ins.	ins.	ins.	ins.	ins.	ins.	ins.	ins.	ins.	ins.	ins.	ins.	ins.	ins.	ins.	ins.	ins.
6' 0"	2 ½ x	2 ½ x	.36	5 x	.34	5 ½ x	.34	6 x	.36	5 x	3 x	.34	5 ½ x	3 x	.34	6 x	3 x	.36
8' 0"	2 ½ x	2 ½ x	.38	6 x	.38	7 x	.40	7 ½ x	.42	6 x	3 x	.38	7x	7 x	.40	7 ½ x	3 ½ x	.42

Status: This is the original version (as it was originally enacted).

Length of Fore-and-Afters.	Mounting.			Bulb Plate. Centre Fore-and-Afters.						Bulb Angle. Side Fore-and-Afters.					
				Spacing Centre to Centre.						Spacing Centre to Centre.					
				3' 0"		4' 0"		5' 0"		3' 0"		4' 0"		5' 0"	
10' 0"	2 ½ x	2 ½ x	.40	7 x .44	8 x .46	9 x .50	7 x .44	3 x .44	8 x .56	3 ½ x	9 x .50	3 ½ x			
	Wood Centre Fore-and-Afters.						Wood Side Fore-and-Afters.								
	Spacing Centre to Centre.						Spacing Centre to Centre.								
	3' 0"		4' 0"		5' 0"		3' 0"		4' 0"		5' 0"				
	D	B	D	B	D	B	D	B	D	B	D	B			
	ins.	ins.	ins.	ins.	ins.	ins.	ins.	ins.	ins.	ins.	ins.	ins.			
6' 0"	5	7	5 ½	7	6	7	5	5	5 ½	5	6	5			
8' 0"	6	7	6 ½	7	7	7	6	5	6 ½	6	7	6			
10' 0"	7	7	7 ½	7	8	7	7	6	7 ½	7	8	7			

A = Plain angle. BP = Bulb plate. P = Plate. D = Depth. B—Breadth.

Depths for hatchway beams are at the middle of the length and are measured from the top mounting to the lower edge. Depths for fore-and-afters are measured from the under side of the hatch covers to the lower edge. Sizes for intermediate lengths and spacing are obtained by interpolation. Where plates are specified, two angles, of the sizes given for mountings, are to be fitted at the upper and at the lower part of the beam. Where bulb plates are specified, two angles, of the size given for mountings, are to be fitted at the upper part of the beam or fore-and-after. Where bulb angles are specified, one angle, of the size given for mountings, is to be fitted at the upper part of the section. Where the specified flanges of an angle are of different dimensions, the larger flange is to be horizontal.

* In ships not exceeding 100 feet in length, the depths of beams which are formed of plates and angles may be 60 per cent. of the depths given above; the depths of beams and steel fore-and-afters formed of bulb angle or bulb plate section may be 80 per cent. of the depths given above; the thickness of plates, bulb angles and bulb plates should correspond to the thickness tabulated for the reduced depths with a minimum thickness of .30 inch; the depths and breadths of wood fore-and-afters may be 80 per cent. of those given in the tables for side fore-and-afters, but the centre fore-and-afters must be not less than 6½ inches wide. In ships between 100 feet and 200 feet in length, the sizes of the beams and fore-and-afters are to be determined by linear interpolation.

RULE XII

Carriers or Sockets.

Carriers or sockets for hatchway beams and fore-and-afters are to be of steel at least 1 inch thick, and are to have a width of bearing surface of at least 3 inches.

RULE XIII

Cleats.

Strong cleats at least 2 ½ inches wide are to be fitted at intervals of not more than 2 feet from centre to centre; the end cleats are to be placed not more than 6 inches from each corner of the hatchway.

Status: This is the original version (as it was originally enacted).

RULE XIV

Battens and Wedges.

Battens and wedges are to be efficient and in good condition.

RULE XV

Tarpaulins.

At least two tarpaulins in good condition, thoroughly waterproofed and of ample strength, are to be provided for each hatchway in an exposed position on freeboard and superstructure decks. The material is to be guaranteed free from jute, and of the standard weight and quality laid down by each Administration.

RULE XVI

Security of Hatchway Covers.

At all hatchways in exposed positions on freeboard and superstructure decks ring bolts or other fittings for lashings are to be provided.

Where the breadth of the hatchway exceeds 60 per cent. of the breadth of the deck in way of the hatchway, and the coamings are required to be 24 inches high, fittings for special lashings are to be provided for securing the hatchway covers after the tarpaulins are battened down.

RULE XVII

*Cargo and other Hatchways in the Freeboard Deck within Superstructures
which are fitted with Closing Appliances less efficient than Class 1.*

The construction and fitting of such hatchways, are to be at least equivalent to the standards laid down in Rule XVIII.

RULE XVIII

Hatchway Coamings and Closing Arrangements.

Cargo, coaling and other hatchways in the freeboard deck within superstructures which are fitted with Class 2 closing appliances are to have coamings at least 9 inches in height and closing arrangements as effective as those required for exposed cargo hatchways whose coamings are 18 inches high.

Where the closing appliances are less efficient than Class 2, the hatchways are to have coamings at least 18 inches in height, and are to have fittings and closing arrangements as effective as those required for exposed cargo hatchways.

RULE XIX

Machinery Space Openings in Exposed Positions on Freeboard and Raised Quarter Decks.

Such openings are to be properly framed and efficiently enclosed by steel casings of ample strength, and where the casings are not protected by other structures their strength is to be specially considered. Doors in such casings are to be of steel, efficiently stiffened, permanently attached, and capable of being closed and secured from both sides. The sills of openings are to be at least 24 inches above the freeboard deck and at least 18 inches above the raised quarter deck.

Fiddley, funnel and ventilator coamings are to be as high above the deck as is reasonable and practicable. Fiddley openings are to have strong steel covers permanently attached in their proper positions.

RULE XX

*Machinery Space Openings in Exposed Positions on
Superstructure Decks other than Raised Quarter Decks.*

Such openings are to be properly framed and efficiently enclosed by strong steel casings. Doors in such cases are to be strongly constructed, permanently attached, and capable of being closed and secured from both sides. The sills of the openings are to be at least 15 inches above superstructure decks. Fiddley, funnel and ventilator coamings are to be as high above the deck as is reasonable and practicable. Fiddley openings are to have strong steel covers permanently attached in their proper positions.

RULE XXI

*Machinery Space Openings in the Freeboard Deck within Superstructures
which are fitted with Closing Appliances less efficient than Class I.*

Such openings are to be properly framed and efficiently enclosed by steel casings. Doors in such casings are to be strongly constructed, permanently attached, and capable of being securely closed. The sills of the openings are to be at least 9 inches above the deck where the superstructures are closed by Class 2 closing appliances, and at least 15 inches above the deck where the closing appliances are less efficient than Class 2.

RULE XXII

Flush Bunker Scuttles.

Flush bunker scuttles may be fitted in superstructure decks, and where so fitted are to be of iron or steel, of substantial construction, with screw or bayonet joints. Where a scuttle is not secured by hinges, a permanent chain attachment is to be provided. The position of flush bunker scuttles in small ships in special trades is to be dealt with by each Assigning Authority.

RULE XXIII

Companionways.

Companionways in exposed positions on freeboard decks and on decks of enclosed superstructures are to be of substantial construction. The sills of the doorways are to be of the heights specified for hatchway coamings (*see* Rules IX and XVILI). The doors are to be strongly constructed and capable of being closed and secured from both sides. Where the companionway is situated within a quarter of the ship's length from the stem, it is to be of steel and riveted to the deck plating.

RULE XXIV

Ventilators in Exposed Positions on Freeboard and Superstructure Decks.

Such ventilators to spaces below freeboard decks or decks of superstructures which are intact or fitted with Class 1 closing appliances are to have coamings of steel, substantially constructed, and efficiently connected to the deck by rivets spaced four diameters apart centre to centre,

Status: This is the original version (as it was originally enacted).

or by equally effective means. The deck plating at the base of the coaming is to be efficiently stiffened between the deck beams. The ventilator openings are to be provided with efficient closing arrangements.

Where such ventilators are situated on the freeboard deck, or on the superstructure deck within a quarter of the ship's length from the stem, and the closing arrangements are of a temporary character, the coamings are to be at least 36 inches in height; in other exposed positions on the superstructure deck they are to be at least 30 inches in height. Where the coaming of any ventilator exceeds 36 inches in height, it is to be specially supported and secured.

RULE XXV

Air Pipes.

Where the air pipes to ballast and other tanks extend above freeboard or superstructure decks, the exposed parts of the pipes are to be of substantial construction; the height from the deck to the opening is to be at least 36 inches in wells on freeboard decks, 30 inches on raised quarter decks, and 18 inches on other superstructure decks. Satisfactory means are to be provided for closing the openings of the air pipes.

OPENINGS IN THE SIDES OF SHIPS.

RULE XXVI

Gangway, Cargo and Coaling Ports, &c.

Openings in the sides of ships below the freeboard deck are to be fitted with watertight doors or covers which, with their securing appliances, are to be of sufficient strength.

RULE XXVII

Scuppers and Sanitary Discharge Pipes.

Discharges led through the ship's sides from spaces below the freeboard deck are to be fitted with efficient and accessible means for preventing water from passing inboard. Each separate discharge may have an automatic non-return valve with a positive means of closing it from a position above the freeboard deck, or two automatic non-return valves without positive means of closing, provided the upper valve is situated so that it is always accessible for examination under service conditions. The positive action valve is to be readily accessible and is to be provided with means for showing whether the valve is open or closed. Cast iron is not to be accepted for such valves where attached to the sides of the ship.

Conditional upon the type and the location of the inboard ends of such openings, similar provisions may be prescribed by the Assigning Authority as to discharges from spaces within enclosed superstructures.

Where scuppers are fitted in superstructures not fitted with Class I closing appliances they are to have efficient means for preventing the accidental admission of water below the freeboard deck.

RULE XXVIII

Side Scuttles.

Side scuttles to spaces below the freeboard deck or to spaces below the superstructure deck of superstructures closed by Class 1 or Class 2 closing appliances are to be fitted with efficient

Status: This is the original version (as it was originally enacted).

inside deadlights permanently attached in their proper positions so that they can be effectively closed and secured watertight.

Where, however, such spaces in superstructures are appropriated to passengers other than steerage passengers or to crew, the side scuttles may have portable deadlights stowed adjacent to the side scuttles, provided they are readily accessible at all times on service.

The side scuttles and deadlights are to be of substantial and approved construction.

RULE XXIX

Guard Rails.

Efficient guard rails or bulwarks are to be fitted on all exposed portions of freeboard and superstructure decks.

RULE XXX

Freeing Ports.

Where bulwarks on the weather portions of freeboard or superstructure decks form "wells," ample provision is to be made for rapidly freeing the decks of water and for draining them. The minimum freeing port area on each side of the ship for each well on the freeboard deck and on the raised quarter-deck is to be that given by the following scale; the minimum area for each well on any other superstructure deck is to be one-half the area given by the scale. Where the length of the well exceeds .7 L, the scale may be modified.

SCALE OF FREEING PORT AREA.

Length of Bulwarks in " Well " in Feet.	Freeing Port Area on each side in Square Feet.
15	8.0
20	8.5
25	9.0
30	9.5
35	10.0
40	10.5
45	11.0
50	11.5
55	12.0
60	12.5
65	13.0
Above 65	1 square foot for each additional 5 feet length of bulwark.

The lower edges of the freeing ports are to be as near the deck as practicable and preferably not higher than the upper edge of the gunwale bar. Two-thirds of the freeing port area required

is to be provided in the midship half of the well. In ships with less than the standard sheer the freeing port area is to be suitably increased.

All such openings in the bulwarks are to be protected by rails or bars spaced about 9 inches apart. If shutters are fitted to freeing ports, ample clearance is to be provided to prevent jamming. Hinges are to have brass pins.

RULE XXXI

Protection of Crew.

Gangways, lifelines or other satisfactory means are to be provided for the protection of the crew in getting to and from their quarters. The strength of houses for the accommodation of crew on flush deck steamers is to be equivalent to that required for superstructure bulkheads.

PART III

LOAD LINE FOR STEAMERS.

RULE XXXII

Length (L).

The length used with the Rules and Freeboard Table is the length in feet on the summer load water-line from the foreside of the stem to the afterside of the rudder post. Where there is no rudder post, the length is measured from the foreside of the stem to the axis of the rudder stock. For ships with cruiser stems, the length is to be taken as 96 per cent. of the total length on the designed summer load water-line or as the length from the fore side of the stem to the axis of the rudder stock if that be the greater.

RULE XXXIII

Breadth (B).

The breadth is the maximum breadth in feet amidships to the moulded line of the frame in iron or steel ships, and to the outside of the planking in wood or composite ships.

RULE XXXIV

Moulded Depth.

The moulded depth is the vertical distance in feet, measured amidships, from the top of the keel to the top of the freeboard deck beam at side. In wood and composite ships the distance is measured from the lower edge of the keel rabbet. Where the form at the lower part of the midship section is of a hollow character, or where thick garboards are fitted, the depth is measured from the point where the line of the flat of the bottom continued inwards cuts the side of the keel.

RULE XXXV

Depth for Freeboard (D).

The depth used with the Freeboard Table is the moulded depth plus the thickness of stringer plate, or plus

T (L—S)
L

if that be greater, where—

T is the mean thickness of the exposed deck clear of deck openings, and
S is the total length of superstructures as defined in Rule XL.

Where the topsides are of unusual form, D is the depth of a midship section having vertical topsides, standard round of beam and area of topside section equal to that in the actual midship section. Where there is a step or break in the topsides (e.g., as in the Turret Deck ship) 70 per cent. of the area above the step or break is included in the area used to determine the equivalent section.

In a ship without an enclosed superstructure covering at least .6 L amidships, without a complete trunk or without a combination of intact partial superstructures and trunk extending all fore and aft, where D is less than

$$\frac{L}{15}$$

, the depth used with the Table is not to be taken as less than

$$\frac{L}{15}$$

RULE XXXVI

Coefficient of Fineness (c).

The coefficient of fineness used with the Freeboard Table is given by—

$$c = \frac{35 \Delta}{L.B.d_1}$$

, where Δ is the ship's moulded displacement in tons (excluding bossing) at a mean moulded draught d_1 which is 85 per cent. of the moulded depth.

The coefficient c is not to be taken as less than .68.

RULE XXXVII

Strength.

The Assigning Authority is to be satisfied with the structural strength of ships to which freeboards are assigned.

Ships which comply with the highest standard of the rules of a Classification Society recognised by the Administration, shall be regarded as having sufficient strength for the minimum freeboards allowed under the Rules.

Ships which do not comply with the highest standard of the rules of a Classification Society recognised by the Administration, shall be assigned such increased freeboards as shall be determined by the Assigning Authority, and for guidance the following strength moduli are formulated :—

Material.—The strength moduli are based on the assumption that the structure is built of mild steel, manufactured by the open hearth process (acid or basic), and having a tensile

Status: This is the original version (as it was originally enacted).

strength of 26 to 32 tons per square inch, and an elongation of at least 16 per cent. on a length of 8 inches.

Strength Deck.—The strength deck is the uppermost deck which is incorporated into and forms an integral part of the longitudinal girder within the half-length amidships.

Depth to Strength Deck (Ds).—The depth to strength deck is the vertical distance in feet amidships from the top of the keel to the top of the strength deck beam at side.

Draught (d).—The draught is the vertical distance in feet amidships from the top of the keel to the centre of the disc.

Longitudinal Modulus.—The longitudinal modulus

$$\frac{I}{y}$$

is the moment of inertia I of the midship section about the neutral axis divided by the distance y measured from the neutral axis to the top of the strength deck beam at side, calculated in way of openings but without deductions for rivet holes. Areas are measured in square inches and distances in feet.

Below the strength deck, all continuous longitudinal members other than such parts of under deck girders as are required entirely for supporting purposes, are included. Above the strength deck, the gunwale angle bar and the extension of the sheerstrake are the only members included.

The required longitudinal modulus for effective material is expressed by f.d.B., where f is the factor obtained from the following table :—

L.	f.
100	1.80
120	2.00
140	2.35
160	2.70
180	3.15
200	3.60
220	4.20
240	4.80
260	5.45
280	6.20
300	6.95
320	7.70
340	8.55
360	9.40
380	10.30
400	11.20
420	12.15
440	13.10

Status: This is the original version (as it was originally enacted).

L.	f.
460	14.15
480	15.15
500	16.25
520	17.35
540	18.45
560	19.60
580	20.80
600	22.00

For intermediate lengths, the value of f is determined by interpolation.

This formula applies where L does not exceed 600 feet; B is between

$$\frac{L}{10} + 5$$

and

$$\frac{L}{10} + 20$$

, both inclusive, and

$$\frac{L}{D_s}$$

is between 10 and 13.5, both inclusive.

Frame.—For the purpose of the frame modulus, the frame is regarded as composed of a frame angle and a reverse angle each of the same size and thickness.

Frame Modulus.— The modulus

$$\frac{I}{y}$$

of the midship frame below the lowest tier of beams is the moment of inertia I of the frame section about the neutral axis divided by the distance y measured from the neutral axis to the extremity of the frame section, calculated without deduction for rivet and bolt holes. The modulus is measured in inch units.

The required frame modulus is expressed by

$$\frac{s (d-t) (f_1 + f_2)}{1,000}$$

, where—

s is the frame spacing in inches.

t is the vertical distance in feet measured at amidships from the top of the keel to a point midway between the top of the inner bottom at side and the top of the heel bracket (*see* Figure 2); where there is no double bottom, t is measured to a point midway between the top of the floor at centre and the top of the floor at side.

f₁ is a coefficient depending on H, which, in ships fitted with double bottoms, is the vertical distance in feet from the middle of the beam bracket of the lowest tier of beams at side to a point midway between the top of the inner bottom at side and the top of the heel bracket (*see* Figure 2). Where there is no double bottom, H is measured to a point midway between the top of the floor at centre and the top of the floor at side. Where

Status: This is the original version (as it was originally enacted).

the frame obtains additional strength from the form of the ship, due allowance is made in the value of f_1

f_2 is a coefficient depending on K, which is the vertical distance in feet from the top of the lowest tier of beams at side to a point 7 feet 6 inches above the freeboard deck at side, or, if there is a superstructure, to a point 12 feet 6 inches above the freeboard deck at side (*see* Figure 2). The values of f_1 and f_2 are obtained from the following tables :—

H in feet	0	7	9	11	13	15	17	19	21	23	25
f_1	9	11	12.5	15	19	24	29.5	36	43	51	59
K in feet	0	5	10	15	20	25	30	35	40		
f_2	0	0.5	10	2.0	30	4.5	6.5	90	12.0		

Intermediate values are obtained by interpolation.

This formula applies where D is between 15 feet and 60 feet, both inclusive, B is between

$$\frac{L}{10} + 5$$

and

$$\frac{L}{10} + 20$$

both inclusive,

$$\frac{L}{Ds}$$

is between 10 and 13.5, both inclusive; and the horizontal distance from the outside of the frame to the centre of the first row of pillars does not exceed 20 feet.

In single deck ships of ordinary form, where H does not exceed 18 feet, the frame modulus determined by the preceding method is multiplied by the factor f_3 where

$$f_3 = .50 + .05 (H - 8)$$

Where the horizontal distance from the outside of the frame to the centre of the first row of pillars exceeds 20 feet, the Assigning Authority is to be satisfied that sufficient additional strength is provided.

Status: This is the original version (as it was originally enacted).

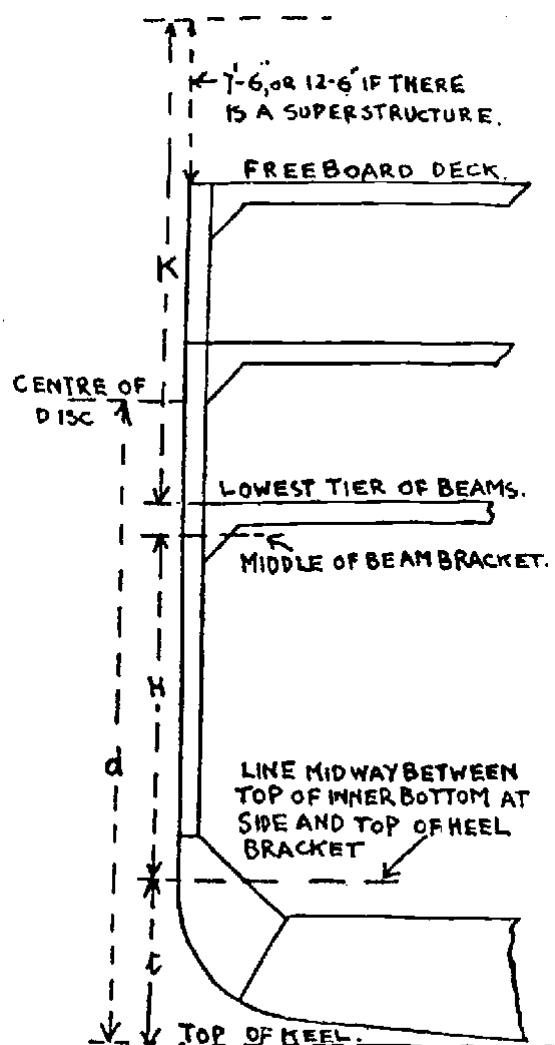

FIGURE 2.

SUPERSTRUCTURES.

RULE XXXVIII

Height of Superstructure.

The height of a superstructure is the least vertical height measured from the top of the superstructure deck to the top of the freeboard deck beams minus the difference between D and the moulded depth (*see*, Rules XXXIV and XXXV).

RULE XXXIX

Standard Height of Superstructure.

The standard height of a raised quarter deck is 3 feet for ships up to and including 100 feet in length, 4 feet for ships 250 feet in length and 6 feet for ships 400 feet in length and above. The standard height of any other superstructure is 6 feet for ships up to and including 250 feet

Status: This is the original version (as it was originally enacted).

in length and 7 feet 6 inches for ships 400 feet in length and above. The standard height at intermediate lengths is obtained by interpolation.

RULE XL

Length of Superstructure (S).

The length of a superstructure is the mean covered length of the parts of the superstructure which extend to the sides of the ship and lie within lines drawn perpendicular to the extremities of the Summer load water-line, as defined in Rule XXXII.

RULE XLI

Enclosed Superstructure.

A detached superstructure is regarded as enclosed only where—

- (a) the enclosing bulkheads are of efficient construction (*see* Rule XLII);
- (b) the access openings in these bulkheads are fitted with Class 1 or Class 2 closing appliances (*see* Rules XLIII and XLIV);
- (c) all other openings in sides or ends of the superstructure are fitted with efficient weathertight means of closing; and
- (d) independent means of access to crew, machinery, bunker and other working spaces within bridges and poops are at all times available when the bulkhead openings are closed.

RULE XLII

Superstructure Bulkheads.

Bulkheads at exposed ends of poops, bridges and forecastles are deemed to be of efficient construction where the Assigning Authority is satisfied that, in the circumstances, they are equivalent to the following standard for ships with minimum freeboards under which standard the stiffness and plating are of the scantlings given in Table 3, the stiffeners are spaced 30 inches apart, the stiffeners on poop and bridge front bulkheads have efficient end connections, and those on after bulkheads of bridges and forecastles extend for the whole distance between the margin angles of the bulkheads.

TABLE 3.

Bridge Front Bulkheads. Unprotected Bulkheads of Poops .4 L or more in Length.		Bulkheads of Poops Partially Protected or less in Length than .4 L.		After Bulkheads of Bridges and Forecastles.	
Length of Ship.	Bulb Angle Stiffeners.	Length of Ship.	Plain Angle Stiffeners.	Length of Ship.	Plain Angle Stiffeners.
Feet.	Inches.	Feet.	Inches.	Feet.	Inches.
Under 160	5 ½ x 3 x .30	Under 150	3 x 2 ½ x .30	Under 150	2 ½ x 2 ½ x .26
160	6 x 3 x .32	150	3 ½ x 2 ½ x .32	150	3 x 2 ½ x .28

Status: This is the original version (as it was originally enacted).

Bridge Front Bulkheads. Unprotected Bulkheads of Poops .4 L or more in Length.		Bulkheads of Poops Partially Protected or less in Length than .4 L.		After Bulkheads of Bridges and Forecastsles.	
Length of Ship.	Bulb Angle Stiffeners.	Length of Ship.	Plain Angle Stiffeners.	Length of Ship.	Plain Angle Stiffeners.
200	6 ½ x 3 x .34	200	4 x 3 x .34	250	3 ½ x 3 x .30
240	7 x 3 x .36	250	4 ½ x 3 x .36	350	4 x 3 x .32
280	7 ½ x 3 x .38	300	5 x 3 x .38		
320	8 x 3 x .40	350	5 ½ x 3 x .42		
360	8 ½ x 3 x .42	400	6 x 3 x .44		
400	9 x 3 x .44	450	6 ½ x 3 ½ x .46		
440	9 ½ x 3 ½ x .46	500	7 x 3 ½ x .48		
480	10 x 3 ½ x .48	550	7 x 3 ½ x .50		
520	10 ½ x 3 ½ x .50				
560	11 x 3 ½ x .52				
Length of Ship. Feet.	Bulkhead Plating. Inch.	Length of Ship. Feet.	Bulkhead Plating. Inch.	Length of Ship. Feet.	Bulkhead Plating. Inch.
200 and under.	.3	160 and under.	.24	160 and under.	.20
380 and above.	.44	400 and above.	.38	400 and above.	.30

For ships intermediate in length the thicknesses of bulkhead plating are obtained by interpolation.

APPLIANCES FOR CLOSING ACCESS OPENINGS IN
 BULKHEADS AT ENDS OF DETACHED SUPERSTRUCTURES.

RULE XLIII

Class 1 Closing Appliances.

These appliances are of iron and steel, are in all cases permanently and strongly attached to the bulkhead, are framed, stiffened and fitted so that the whole structure is of equivalent strength to the unpierced bulkhead, and are weathertight when closed. The means for securing these appliances are permanently attached to the bulkhead or to the appliances and the latter are so arranged that they can be closed and secured from both sides of the bulkhead or from the deck above. The sills of the access openings are at least 15 inches above the deck.

Status: This is the original version (as it was originally enacted).

RULE XLIV

Class 2 Closing Appliances.

These appliances are (a) strongly framed hard wood hinged doors, which are not more than 30 inches wide nor less than 2 inches thick; or (6) shifting boards fitted for the full height of the opening in channels riveted to the bulkhead, the shifting boards being at least 2 inches thick where the width of opening is 30 inches or less, and increased in thickness at the rate of 1 inch for each additional 15 inches of width, or (c) portable plates of equal efficiency.

TEMPORARY APPLIANCES FOR CLOSING OPENINGS IN SUPERSTRUCTURE DECKS.

RULE XLV

Temporary closing appliances for middle line openings in the deck of an enclosed superstructure consist of—

- (a) a steel coaming not less than 9 inches in height efficiently riveted to the deck;
- (b) hatchway covers as required by Rule X, secured by hemp lashings; and
- (c) hatchway supports as required by Rules XI and XII and Table 1 or 2.

EFFECTIVE LENGTH OF DETACHED SUPERSTRUCTURES.

RULE XLVI

General.

Where exposed bulkheads at the ends of poops, bridges, and forecastles are not of efficient construction (*see* Rule XLII) they are considered as non-existent.

Where in the side plating of a superstructure there is an opening not provided with permanent means of closing, the part of the superstructure in way of the opening is regarded as having no effective length.

Where the height of a superstructure is less than the standard its length is reduced in the ratio of the actual to the standard height. Where the height exceeds the standard, no increase is made in the length of the superstructure.

RULE XLVII

Poop.

Where there is an efficient bulkhead and the access openings are fitted with Class 1 closing appliances, the length to the bulkhead is effective. Where the access openings in an efficient bulkhead are fitted with Class 2 closing appliances and the length to the bulkhead is .5 L or less, 100 per cent. of that length is effective; where the length is .7 L or more, 90 per cent. of that length is effective; where the length is between .5 L and .7 L, an intermediate percentage of that length is effective; where an allowance is given for an efficient adjacent trunk (*see* Rule LI), 90 per cent. of the length to the bulkhead is to be taken as effective. 50 per cent. of the length of an open poop or of an open extension beyond an efficient bulkhead is effective.

Status: This is the original version (as it was originally enacted).

RULE XLVIII

Raised Quarter Deck.

Where there is an efficient intact bulkhead, the length to the bulkhead is effective. Where the bulkhead is not intact, the superstructure is considered as a poop of less than standard height.

RULE XLIX

Bridge.

Where there is an efficient bulkhead at each end, and the access openings in the bulkheads are fitted with Class 1 closing appliances, the length between the bulkheads is effective.

Where the access openings in the forward bulkhead are fitted with Class 1 closing appliances and the access openings in the after bulkhead with Class 2 closing appliances, the length between the bulkheads is effective; where an allowance is given for an efficient trunk, adjacent to the after bulkhead (*see* Rule LI), 90 per cent. of the length is effective. Where the access openings in both bulkheads are fitted with Class 2 closing appliances, 90 per cent. of the length between the bulkheads is effective. Where the access openings in the forward bulkhead are fitted with Class 1 or Class 2 closing appliances and the access openings in the after bulkhead have no closing appliances, 75 per cent. of the length between the bulkheads is effective. Where the access openings in both bulkheads have no closing appliances, 50 per cent. of the length is effective. 75 per cent. of the length of an open extension beyond the after bulkhead, and 50 per cent. of that beyond the forward bulkhead, are effective.

RULE L

Forecastle.

Where there is an efficient bulkhead and the access openings are fitted with Class 1 or Class 2 closing appliances, the length to the bulkhead is effective. Where no closing appliances are fitted and the sheer forward of amidships is not less than the standard sheer, 100 per cent. of the length of the forecastle forward of -1 L from the forward perpendicular is effective; where the sheer forward is half the standard sheer or less, 50 per cent. of that length is effective; and where the sheer forward is intermediate between the standard and half the standard sheer, an intermediate percentage of that length is effective. 50 per cent. of the length of an open extension beyond the bulkhead or beyond .1 L from the forward perpendicular is effective.

RULE LI

Trunk.

A trunk or similar structure which does not extend to the sides of the ship is regarded as efficient provided that—

- (a) the trunk is at least as strong as a superstructure;
- (b) the hatchways are in the trunk deck, and comply with the requirements of Rules VIII to XVI, and the width of the trunk deck stringer provides a satisfactory gangway and sufficient lateral stiffness;
- (c) a permanent working platform fore and aft fitted with guard rails is provided by the trunk deck, or by detached trunks connected to other superstructures by efficient permanent gangways;
- (d) ventilators are protected by the trunk, by watertight covers or by equivalent means;

Status: This is the original version (as it was originally enacted).

- (e) open rails are fitted on the weather portions of the free board deck in way of the trunk for at least half their length;
- (f) the machinery casings are protected by the trunk, by a superstructure of standard height, or by a deck house of the same height and of equivalent strength.

Where access openings in poop and bridge bulkheads are fitted with Class 1 closing appliances, 100 per cent. of the length of an efficient trunk reduced in the ratio of its mean breadth to B is added to the effective length of the superstructures. Where the access openings in these bulkheads are not fitted with Class 1 closing appliances 90 per cent. is added.

The standard height of a trunk is the standard height of a bridge.

Where the height of the trunk is less than the standard height of a bridge, the addition is reduced in the ratio of the actual to the standard height; where the height of hatchway coamings on the trunk deck is less than the standard height of coamings (*see* Rule IX), a reduction from the actual height of trunk is to be made which corresponds to the difference between the actual and the standard height of coamings.

EFFECTIVE LENGTH OF ENCLOSED SUPERSTRUCTURES WITH MIDDLE LINE OPENINGS.

RULE LII

Enclosed Superstructure with Middle Line Openings in the deck not Provided with Permanent Means of Closing.

Where there is an enclosed superstructure with one or more middle line openings in the deck not provided with permanent means of closing (*see* Rules VIII to XVI), the effective length of the superstructure is determined as follows :—

- (1) Where efficient temporary closing appliances are not provided for the middle line deck openings (*see* Rule XLV), or the breadth of opening is 80 per cent. or more of the breadth B_1 , of the superstructure deck at the middle of the opening, the ship is considered as having an open well in way of each opening, and freeing ports are to be provided in way of this well. The effective length of superstructure between openings is governed by Rules XLVII, XLIX, and L.
- (2) Where efficient temporary closing appliances are provided for middle line deck openings and the breadth of opening is less than $.8 B_1$, the effective length is governed by Rules XLVII, XLIX, and L, except that where access openings in 'tween deck bulkheads are closed by Class 2 closing appliances, they are regarded as being closed by Class 1 closing appliances in determining the effective length. The total effective length is obtained by adding to the length determined by (1) the difference between this length and the length of the ship modified in the ratio of—

$$\frac{B_1 - b}{B_1}$$

where b = breadth of deck opening;

where

$$\frac{B_1 - b}{B_1}$$

is greater than $.5$ it is taken as $.5$.

Status: This is the original version (as it was originally enacted).

DEDUCTIONS FOR SUPERSTRUCTURES.

RULE LIII

Deductions for Superstructures.

Where the effective length of superstructures is 1.0 L, the deduction from the freeboard is 14 inches at 80 feet length of ship, 34 inches at 280 feet length, and 42 inches at 400 feet length and above; deductions at intermediate lengths are obtained by interpolation. Where the total effective length of superstructures is less than 1.0 L the deduction is a percentage obtained from the following Table :—

Superstructures.	Total Effective Length of Superstructure (E).											Line.
	0L	.1L	.2L	.3L	.4L	.5L	.6L	.7L	.8L	.9L	1.0L	
	Percent	Percent	Percent	Percent	Percent	Percent	Percent	Percent	Percent	Percent	Percent	
All types with forecastle and without detached bridge	0	5	10	15	23.5	32	46	63	75.3	87.7	100	A
All types with forecastle and detached bridge*	0	6.3	12.7	19	27.5	36	46	63	75.3	87.7	100	B

* Where the effective length of a detached bridge is less than .2L the Percentages are obtained by interpolation between lines B and A.

Where no forecastle is fitted the above percentage are reduced by 5.

Percentages for intermediate lengths of superstructures are obtained by interpolation.

SHEER.

RULE LIV

General.

The sheer is measured from the deck at side to a line of reference drawn parallel to the keel through the sheer line at amidships.

In ships designed to trim by the stern in service, the sheer may be measured in relation to the load line, provided an additional mark is placed at .25 L forward of amidships, to indicate the assigned load line. This mark is to be similar to the load line disc amidships.

In flush deck ships and in ships with detached superstructures the sheer is measured at the freeboard deck.

Status: This is the original version (as it was originally enacted).

In ships with topsides of unusual form in which there is a step or break in the topsides, the sheer is considered in relation to the equivalent depth amidships (*see* Rule XXXV).

In ships with a superstructure of standard height which extends over the whole length of the freeboard deck, the sheer is measured at the superstructure deck; where the height exceeds the standard, the sheer may be considered in relation to the standard height.

Where a superstructure is intact or access openings in its enclosing bulkheads are fitted with Class 1 closing appliances, and the superstructure deck has at least the same sheer as the exposed freeboard deck, the sheer of the enclosed portion of the freeboard deck is not taken into account.

RULE LV

Standard Sheer Profile.

The ordinates (in inches) of the standard sheer profile are given in the following Table, where L is the number of feet in the length of the ship :—

Station.	Ordnate.	Factor.
A.P.	.1 L + 10	1
1/6 L from A.P.	.0445 L + 4-45	4
1/3 L from A.P.	.01 L + 1-1	2
Amidships.	0	4
1/3 L from F.P.	.022 L + 2-2	2
1/6 L from F.P.	.089 L + 89	4
F.P.	.2 L + 20	1

A.P. = After end of Summer load water-line. F.P. = Fore end of Summer load water-line.

RULE LVI

Measurement of Variations from Standard Sheer Profile.

Where the sheer profile differs from the standard, the seven ordinates of each profile are multiplied by the appropriate factors given in the table of ordinates. The difference between the sums of the respective products, divided by 18, measures the deficiency or excess of sheer. Where the after half of the sheer profile is greater than the standard and the forward half is less than the standard, no credit is allowed for the part in excess and the deficiency only is measured.

Where the forward half of the sheer profile exceeds the standard, and the after portion of the sheer profile is not less than 75 per cent. of the standard, credit is allowed for the part in excess; where the after part is less than 50 per cent. of the standard no credit is given for the excess sheer forward. Where the after sheer is between 50 per cent. and 75 per cent. of the standard, intermediate allowances may be granted for excess sheer forward.

RULE LVII

Correction for Variations from Standard Sheer Profile

The correction for sheer is the deficiency or excess of sheer (*see* Rule LVI), multiplied by

$$.75 - \frac{S}{2L}$$

, where S is the total length of superstructure, as defined in Rule XL.

RULE LVIII

Addition for Deficiency in Sheer.

Where the sheer is less than the standard, the correction for deficiency in sheer (*see* Rule LVII) is added to the freeboard.

RULE LIX

Deduction for Excess Sheer.

In flush deck ships and in ships where an enclosed superstructure covers .1 L before and .1 L abaft amidships, the correction for excess of sheer (*see* Rule LVII) is deducted from the freeboard; in ships with detached superstructures where no enclosed superstructure covers amidships, no deduction is made from the freeboard; where an enclosed superstructure covers less than .1 L before and .1 L abaft amidships, the deduction is obtained by interpolation. The maximum deduction for excess sheer is 1 ½ inches at 100 feet and increases at the rate of 1 ½ inches for each additional 100 feet in the length of the ship.

HOUND OF BEAM.

RULE LX

Standard Round of Beam.

The standard round of beam of the freeboard deck is one-fiftieth of the breadth of the ship.

RULE LXI

Round of Beam Correction.

Where the round of beam of the freeboard deck is greater or less than the standard, the freeboard is decreased or increased respectively by one-fourth of the difference between the actual and the standard round of beam, multiplied by the proportion of the length of the freeboard deck not covered by enclosed superstructures. Twice the standard round of beam is the maximum for which allowance is given.

MINIMUM FREEBOARD.

RULE LXII

Summer Freeboard.

The minimum freeboard in Summer is the freeboard derived from the Freeboard Table after corrections for departures from the standards and after deduction for superstructures.

The freeboard in salt water measured from the intersection of the upper surface of the freeboard deck with the outer surface of the shell is not to be less than 2 inches.

Status: This is the original version (as it was originally enacted).

RULE LXIII

Tropical Freeboard.

The minimum freeboard in the Tropical Zone is the freeboard obtained by a deduction from the Summer freeboard of J inch per foot of Summer draught measured from the top of the keel to the centre of the

The freeboard in salt water measured from the intersection of the upper surface of the freeboard deck with the outer surface of the shell is not to be less than 2 inches.

RULE LXIV

Winter Freeboard.

The minimum freeboard in Winter is the freeboard obtained by an addition to the Summer freeboard of J inch per foot of Summer draught, measured from the top of the keel to the centre of the disc.

RULE LXV

Winter North Atlantic Freeboard.

The minimum freeboard for ships not exceeding 330 feet in length on voyages across the North Atlantic, North of latitude 36° N., during the winter months, is the Winter freeboard plus two inches; for ships over 330 feet in length it is the Winter freeboard.

RULE LXVI

Fresh Water Freeboard.

The minimum freeboard in fresh water of unit density is the freeboard obtained by deducting from the minimum freeboard in salt water

$$\frac{\Delta}{40 T}$$

inches, where

Δ = displacement in salt water in tons at the Summer load water-line, and

T = tons per inch immersion in salt water at the Summer load water-line.

Where the displacement at the Summer load water-line cannot be certified, the deduction is to be J inch per foot of Summer draught measured from the top of the keel to the centre of the disc.

RULE LXVII

Freeboard Table for Steamers.

Basic Minimum Summer Freeboards for Steamers which Comply with the Standards Laid Down in the Rules.

L.	Freeboard.
(Feet)	(Inches)
80	8.0
90	9.0

Status: This is the original version (as it was originally enacted).

L.	Freeboard.
100	10.0
110	11.0
120	12.0
130	13.0
140	14.2
150	15.5
160	16.9
170	18.3
180	19.8
190	21.4
200	23.1
210	24.8
220	26.6
230	28.5
240	30.3
250	32.3
260	34.4
270	36.5
280	38.7
290	41.0
300	43.4
310	45.9
320	48.4
330	51.0
340	53.7
350	56.5
360	59.4
370	62.4
380	65.4
390	68.4
400	71.5
410	74.6
420	77.8
430	80.9

Status: This is the original version (as it was originally enacted).

L.	Freeboard.
440	84.0
450	87.1
460	90.2
470	93.3
480	96.3
490	99.3
500	102.3
510	105.2
520	108.1
530	110.9
540	113.7
550	116.4
560	119.1
570	121.8
580	124.4
590	127.0
600	129.5
610	132.0
620	134.4
630	136.8
640	139.1
650	141.4
660	143.7
670	145.9
680	148.1
690	150.2
700	152.3
710	154.4
720	156.4
730	158.5
740	160.5
750	162.5

(i) The minimum freeboards for flush deck steamers are obtained by an addition to the above Table at the rate of 1½ inches for every 100 feet of length.

- (ii) The freeboards at intermediate lengths are obtained by interpolation.
(iii) Where c exceeds .68, the freeboard is multiplied by the factor

$$\frac{c + .68}{1.36}$$

- (iv) Where D exceeds

$$\frac{L}{15}$$

the freeboard is increased by

$$\left\{ D - \frac{L}{15} \right\} R$$

inches, where R is

$$\frac{L}{130}$$

at lengths less than 390 feet, and 3 at 390 feet length and above.

In a ship with an enclosed superstructure covering at least .6 L amidships, with a complete trunk, or with a combination of intact partial superstructures and trunk which extends all fore and aft, where D is less than

$$\frac{L}{15}$$

, the freeboard is reduced at the above rate. Where the height of superstructures or trunk is less than the standard height, the reduction is in the ratio of the actual to the standard height.

- (v) Where the actual depth to the surface of the freeboard deck amidships is greater or less than D , the difference between the depths (in inches) is added to or deducted from the freeboard.

PART IV

LOAD LINES FOR SAILING SHIPS.

RULE LXVIII

Lines to be Used in Connection with the Disc.

Winter and Tropical load lines are not marked on sailing ships. The maximum load line to which sailing ships may be laden in salt water in Winter and in the Tropical Zone is the centre of the disc (*see* Figure 3).

Status: This is the original version (as it was originally enacted).

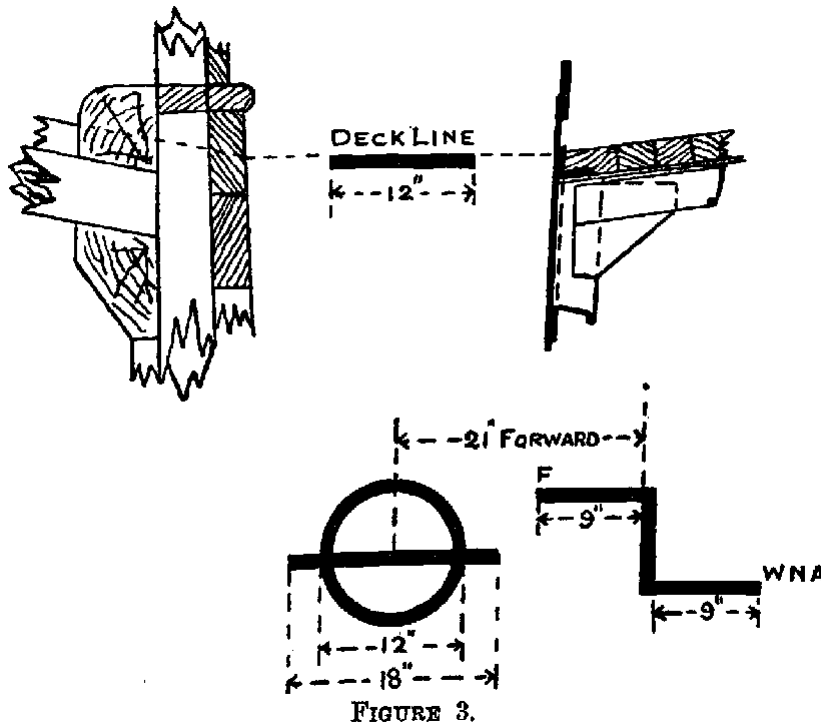

FIGURE 3.

RULE LXIX

Conditions of Assignment of Load Line.

The conditions of assignment are those contained in Part II of these Rules.

RULE LXX

Computation of Freeboard.

Freeboards are computed from the Freeboard Table for Sailing Ships in the same manner as the freeboards for steamers are computed from the Freeboard Table for Steamers, except as follows:—

RULE LXXI

Depth for Freeboard (D).

In sailing ships having a greater rate of rise of floor than $1\frac{1}{2}$ inches per foot, the vertical distance from the top of keel (Rule XXXIV), is reduced by half the difference between the total rise of floor at the half-breadth of the ship and the total rise at $1\frac{1}{2}$ inches per foot. $2\frac{1}{2}$ inches per foot of half-breadth is the maximum rate of rise for which a deduction is made.

Where the form at the lower part of the midship section is of a hollow character, or thick garboards are fitted, the depth is measured from the point where the line of the flat of the bottom continued inwards cuts the side of the keel.

The depth used with the Freeboard Table is to be taken as not less than

Status: This is the original version (as it was originally enacted).

L
12

RULE LXXII

Coefficient of Fineness (c).

The coefficient used with the Freeboard Table is to be taken as not less than .62 and not greater than .72.

RULE LXXIII

Superstructures in Wood Ships.

In wood ships the construction and closing arrangements of superstructures for which deductions are made from the freeboard are to be to the satisfaction of the Assigning Authority Rule LXXIV

Deductions for Superstructures.

Where the effective length, pi superstructures is 1.0 L, the deduction from the freeboard is 8 inches at 80 feet length of ship, and 28 inches at 330 feet length and above; deductions at intermediate lengths are obtained by interpolation. Where the total effective length of superstructures is less than 1.0 L, the deduction is a percentage obtained from the following Table :—

Type of Superstructures.	Total Effective Length of Superstructures (E).											Line.
	0	.1 L	.2 L	.3L	.4L	.5L	.6L	.7 L	.8L	.9L	1.0L	
	%	%	%	%	%	%	%	%	%	%	%	
All types without Bridge	0	7	13	17	23.5	30	47 ½	70	80	90	100	A
All types with Bridge*	0	7	14.7	22	32	42	56	70	80	90	100	B

* Where the effective length of Bridge is less than .2 L, the percentages are obtained by interpolation between lines B and A. Percentages for intermediate lengths of superstructures are obtained by interpolation.

RULE LXXV

Minimum Freeboards.

No addition to the freeboard is required for Winter freeboard, nor is a deduction permitted for Tropical freeboard.

An increase in freeboard of 3 inches is made for voyages across the North Atlantic North of latitude 36° N. during the winter months.

Status: This is the original version (as it was originally enacted).

In computing the fresh water freeboard for a wood ship, the draught is measured from the lower edge of the rabbet of keel to the centre of the disc.

RULE LXXVI

Freeboard Table for Sailing Ships.

Minimum Summer, Winter, and Tropical Freeboards for Iron and Steel Flush Deck Sailing Ships, which comply with the Standards laid down in the Rules.

L.	Freeboard.
Feet.	Inches.
80	9.2
90	11.0
100	12.9
110	14.9
120	17.0
130	19.1
140	21.3
150	23.5
160	25.8
170	28.2
180	30.6
190	33.0
200	35.4
210	37.9
220	40.4
230	42.9
240	45.5
250	48.1
260	50.8
270	53.5
280	56.3
290	59.1
300	61.9
310	64.7
320	67.6
330	70.5

- (i) The freeboards at intermediate lengths are obtained by interpolation.
(ii) Where c exceeds .62, the freeboard is multiplied by the factor

$$\frac{c + .62}{1.24}$$

- (iii) Where D exceeds

$$\frac{L}{12}$$

the freeboard is increased by

$$\left\{ D - \frac{L}{12} \right\} \times \left\{ 1 + \frac{L}{250} \right\}$$

inches.

- (iv) Where the actual depth to the surface of the freeboard deck amidships is greater or less than D , the difference between the depths (in inches) is added to or deducted from the freeboard.

RULE LXXVII

Freeboard for Wood Sailing Ships.

The freeboard for a wood sailing ship is the final freeboard the ship would obtain if she were of iron and steel, with the addition of such penalties as the Assigning Authority may determine, having regard to the classification, construction, age and condition of the ship.

Wood ships of primitive build such as dhows, junks, prahus, &c, are to be dealt with by the Administration so far as is reasonable and practicable under the Rules for Sailing Ships.

PART V

LOAD LINES FOR STEAMERS CARRYING TIMBER DECK CARGOES.

Definitions.

Timber Deck Cargo.—The term "timber deck cargo" means a cargo of timber carried on an uncovered part of a freeboard or superstructure deck. The term does not include wood pulp or similar cargo.

Timber Load Line.—A timber load line is a special load line to be used only when the ship is carrying a timber deck cargo in compliance with the following conditions and regulations:—

RULE LXXVIII

Marks on the Ship's Sides.

Timber Load Lines.—The lines which indicate the maximum timber load lines in different circumstances and at different seasons are to be horizontal lines, 9 inches in length and 1 inch in breadth, which extend from, and are at right angles to, a vertical line marked 21 inches abaft the centre of the disc (*see* Figure 4). They are to be marked and verified similarly to the ordinary load lines (*see* Rules V to VII).

The Summer Timber Load Line is indicated by the upper edge of a line marked LS.

The Winter Timber Load Line is indicated by the upper edge of a line marked LW.

Status: This is the original version (as it was originally enacted).

The Winter North Atlantic Timber Load Line is indicated by the upper edge of a line marked LWNA.

The Tropical Timber Load Line is indicated by the upper edge of a line marked LT.

The Fresh Water Timber Load Line in Summer is indicated by the upper edge of a line marked LF. The difference between the Fresh Water Timber load line in Summer and the Summer Timber load line is the allowance to be made for loading in fresh water at the other Timber load lines. The Fresh Water Timber load line in the Tropical Zone is indicated by the upper edge of a line marked LTF.(3)

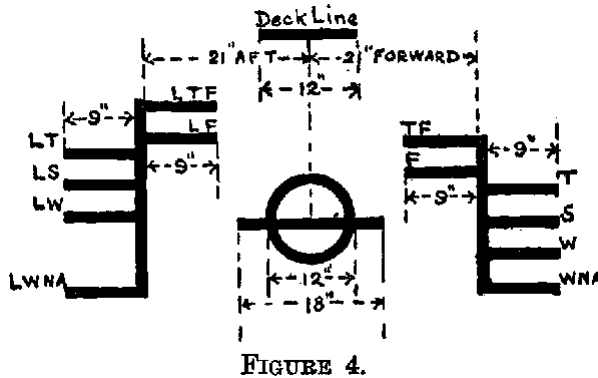

FIGURE 4.

SUPPLEMENTARY CONDITIONS OF ASSIGNMENT AND REGULATIONS FOR DEEPER LOADING.

RULE LXXIX

Construction of Ship.

The structure of the ship is to be of sufficient strength for the deeper draught allowed and for the weight of the deck cargo.

RULE LXXX

Superstructures.

The ship is to have a forecastle of at least standard height and at least 7 per cent. of the length of the ship, and, in addition, a poop, or a raised quarter deck with a strong steel hood or deck house fitted aft.

RULE LXXXI

Machinery Casings.

Machinery casings on the freeboard deck are to be protected by a superstructure of at least standard height, unless the machinery casings are of sufficient strength and height to permit of the carriage of timber alongside.

(3) Where seagoing steamers navigate a river or inland water, deeper loading is permitted corresponding to the weight of fuel, &c, required for consumption between the point of departure and the open sea.

Status: This is the original version (as it was originally enacted).

RULE LXXXII

Double Bottom Tanks.

Double bottom tanks where fitted within the midship half length of the ship are to have adequate longitudinal subdivision.

RULE LXXXIII

Bulwarks.

The ship must be fitted either with permanent bulwarks at least 3 feet 3 inches high, specially stiffened on the upper edge and supported by strong bulwark stays attached to the deck in the way of the beams and provided with necessary freeing ports, or with efficient rails of the same height as the above and of specially strong construction.

RULE LXXXIV

Deck Openings covered by Timber Deck Cargo.

Openings to spaces below the freeboard deck are to be securely closed and battened down. Ah fittings, such as hatchway beams, fore-and-afters, and covers, are to be in place. Where hold ventilation is needed, the ventilators are to be efficiently protected.

RULE LXXXV

Stowage.

The wells on the freeboard deck are to be filled with timber stowed as solidly as possible, to at least the standard height of a bridge.

On a ship within a seasonal winter zone in winter, the height of the deck cargo above the freeboard deck is not to exceed one-third of the extreme breadth of the ship.

All timber deck cargo is to be compactly stowed, lashed and secured, it must not interfere in any way with the navigation and necessary work of the ship or with the provision of a safe margin of stability at all stages of the voyage, regard being given to additions of Weight, such as those due to absorption of water and to losses of weight such as those due to consumption of fuel and stores.

RULE LXXXVI

Protection of Crew, Access to Machinery Space, &C.

Safe and satisfactory access to the quarters of the crew, to the machinery space and to all other parts used in the necessary work of the ship, is to be available at all times. Deck cargo in way of openings which give access to such parts is to be so stowed that the openings can be properly closed and secured against the admission of water. Efficient protection for the crew in the form of guard rails or life lines, spaced not more than 12 inches apart vertically, is to be provided on each side of the deck cargo to a height of at least 4 feet above the cargo. The cargo is to be made sufficiently level for gangway purposes.

Status: This is the original version (as it was originally enacted).

RULE LXXXVII

Steering Arrangements.

Steering arrangements are to be effectively protected from damage by cargo, and, as far as practicable are to be accessible. Efficient provision is to be made for steering in the event of a breakdown in the main steering arrangements.

RULE LXXXVIII

Uprights.

Uprights when required by the nature of the timber are to be of adequate strength and may be of wood or metal; the spacing is to be suitable for the length and character of timber carried, but is not to exceed 10 feet. Strong angles or metal sockets efficiently secured to the stringer plate or equally efficient means are to be provided for securing the uprights.

RULE LXXXIX

Lashings.

Timber deck cargo is to be efficiently secured throughout its length by independent overall lashings spaced not more than 10 feet apart.

Eye plates for these lashings are to be riveted to the sheer-strake at intervals of not more than 10 feet, the distance from an end bulkhead of a superstructure to the first eye plate being not more than 6 feet 6 inches. Additional eye plates may be fitted on the stringer plate.

Overall lashings are to be in good condition and are to be not less than $\frac{3}{4}$ inch close link chain or flexible wire rope of equivalent strength, fitted with sliphooks and stretching screws, which are to be accessible at all times. Wire rope lashings are to have a short length of long link chain to permit the length of lashings to be regulated.

When timber is in lengths less than 12 feet, the spacing of the lashings is to be reduced to suit the length of timber or other suitable provision made.

When the spacing of the lashings is 5 feet or less, the size of the lashing may be reduced, but not less than $\frac{1}{2}$ inch chain or equivalent wire rope is to be used.

All fittings required for securing the lashings are to be of strength corresponding to the strength of the lashings.

On superstructure decks, uprights, where fitted, are to be about 10 feet apart and are to be secured by athwartship lashings of ample strength.

RULE XC

Plans.

Plans showing the fittings and arrangements for stowing and securing timber deck cargoes in compliance with the foregoing conditions and regulations are to be submitted to the Assigning Authority.

Status: This is the original version (as it was originally enacted).

FREEBOARD.

RULE XCI

Computation of Freeboard.

Where the Assigning Authority is satisfied that the ship is suitable and that the conditions and arrangements are at least equal to the foregoing requirements for the carriage of timber deck cargo, the Summer freeboards computed in accordance with the Rules and Tables in Part III may be modified to give special timber freeboards, by substituting the following percentages for those in Rule LIII :—

TOTAL EFFECTIVE LENGTH OF SUPERSTRUCTURES.

	0	.1L	.2L	.3L	.4L	.5L	.6L	.7L	.8L	.9 L	1.0 L
	%	%	%	%	%	%	%	%	%	%	%
All types	20	30.75	41.5	52.25	63	69.25	75.5	81.5	87.5	93.75	100

The Winter Timber freeboard is to be obtained by adding to the Summer Timber freeboard one-third of an inch per foot of the moulded Summer Timber draught.

The Winter North Atlantic Timber freeboards are the Winter North Atlantic freeboards prescribed in Rule LXV.

The Tropical Timber freeboard is to be obtained by deducting from the Summer Timber freeboard one-quarter of an inch per foot of the moulded Summer Timber draught.

PART IV

LOAD LINES FOR TANKERS.

Definition.

Tanker.—The term " tanker " includes all steamers specially constructed for the carriage of liquid cargoes in bulk.

RULE XCII

Marks on the Ship's Sides.

The marks on the ship's sides are to be as provided in the figure in Rule IV.

SUPPLEMENTARY CONDITIONS OF ASSIGNMENT FOR DEEPER LOADING.

RULE XCIII

Construction of Ship.

The structure of the ship is to be of sufficient strength for the increased draught corresponding to the freeboard assigned.

Status: This is the original version (as it was originally enacted).

RULE XCIV

Forecastle.

The ship is to have a forecastle of which the length is not less than 7 per cent. of the length of the ship and the height is not less than the standard height.

RULE XCV

Machinery Casings.

The openings in machinery casings on the freeboard deck are to be fitted with steel doors. The casings are to be protected by an enclosed poop or bridge of at least standard height, or by a deck house of equal height and of equivalent strength. The bulkheads at the ends of these structures are to be of the scantlings required for bridge front bulkheads. All entrances to the structures from the freeboard deck are to be fitted with effective closing appliances and the sills are to be at least 18 inches above the deck. Exposed machinery casings on the superstructure deck are to be of substantial construction, and all openings in them are to be fitted with steel closing appliances permanently attached to the casings and capable of being closed and secured from both sides; the sills of such openings are to be at least 15 inches above the deck. Fiddley openings are to be as high above the superstructure deck as is reasonable and practicable and are to have strong steel covers permanently attached in their proper positions.

RULE XCVI

Gangway.

An efficiently constructed permanent gangway of sufficient strength for its exposed position is to be fitted fore and aft at the level of the superstructure deck between the poop and midship bridge, and when crew are berthed forward, from the bridge to the forecastle, or other equivalent means of access may be provided to carry out the purpose of the gangway, such as passages below deck.

RULE XCVII

Protection of Crew, Access to Machinery Space, &c.

Safe and satisfactory access from the gangway level to the quarters of the crew, the machinery space and all other parts used in the necessary work of the ship, is to be available at all times. This rule does not apply to pump rooms entered from the freeboard deck, when fitted with Class 1 closing appliances.

RULE XCVIII

Hatchways.

All hatchways on the freeboard deck and on the deck of expansion trunks are to be closed watertight by efficient steel covers.

RULE XCIX

Ventilators.

Ventilators to spaces below the freeboard deck are to be of ample strength or are to be protected by superstructures or equally efficient means.

Status: This is the original version (as it was originally enacted).

RULE C

Freeing Arrangements.

Ships with bulwarks are to have open rails fitted for at least half the length of the exposed portion of the weather deck or other effective freeing arrangements. The upper edge of the sheer-strake is to be kept as low as practicable, and preferably not higher than the upper edge of the gunwale bar.

Where superstructures are connected by trunks, open rails are to be fitted for the whole length of the weather portions of the freeboard deck.

RULE CI

Plans.

Plans showing proposed fittings and arrangements are to be submitted to the Assigning Authority for approval.

FREEBOARDS.

RULE CII

Computation of Freeboard.

When the Assigning Authority is satisfied that the foregoing requirements are fulfilled, the Summer freeboard may be computed from the Table for Tankers; all corrections except those for flush-deck steamers, detached superstructures, excess sheer, and winter voyages across the North Atlantic are to be made in accordance with Part III of the Rules.

RULE CIII

Deduction for Detached Superstructures.

When the total effective length of superstructure is less than 1.0 L, the deduction is a percentage of that for a superstructure of length 1.0 L, and is obtained from the following table :—

TOTAL EFFECTIVE LENGTH OF SUPERSTRUCTURES.

	0	.1L	.2L	.3L	.4L	.5L	.6L	.7L	.8L	.9 L	1.0 L
	%	%	%	%	%	%	%	%	%	%	%
All types	0	7	14	21	31	41	52	63	75.3	87.7	100

RULE CIV

Deduction for Excess Sheer.

Where the sheer is greater than the standard, the correction for excess sheer (*see* Rule LVII of Part III, Load Lines for Steamers) is deducted from the freeboard for all tankers. Rule LIX of Part III does not apply except that the maximum deduction for excess sheer is ½ inches at 100 feet and increases at the rate of ½ inches for each additional 100 feet in the length of the ship.

Status: This is the original version (as it was originally enacted).

RULE CV

Winter North Atlantic Freeboard.

The minimum freeboard for voyages across the North Atlantic, north of latitude 36° N., during the winter months, is the Winter Freeboard plus an addition at a rate of 1 inch per 100 feet in length.

RULE CVI

Freeboard Table for Tankers.

L in Feet.	Freeboard in Inches
190	21.5
200	23.1
210	24.7
220	26.3
230	28.0
240	29.7
250	31.5
260	33.3
270	35.2
280	37.1
290	39.1
300	41.1
310	43.1
320	45.1
330	47.1
340	49.2
350	51.3
360	53.5
370	55.7
380	57.9
390	60.2
400	62.5
410	64.9
420	67.4
430	69.9
440	72.5

Ships above 600 feet are to be dealt with by the Administration.

Status: This is the original version (as it was originally enacted).

L in Feet.	Freeboard in Inches
450	75.1
460	77.7
470	80.2
480	82.7
490	85.1
500	87.5
510	89.8
520	92.1
530	94.3
540	96.5
550	98.6
560	100.7
570	102.7
580	104.6
590	106.5
600	108.4

Ships above 600 feet are to be dealt with by the Administration.

Status: This is the original version (as it was originally enacted).

ANNEX II

Boundaries of the Zones and Seasonal Areas

Zones.

The southern boundary of the northern " Winter Seasonal " zone is a line drawn from the east coast of North America along the parallel of lat. 36° N. to Tarifa in Spain; from the east coast of Korea along the parallel of lat. 35° N. to the west coast of Honshiu, Japan; from the east coast of Honshiu along the parallel of lat. 35° N. to long. 150° W., and thence along a rhumb line to the west coast of Vancouver Island at lat. 50° N., Fusan (Korea) and Yokohama to be considered as being on the boundary line of the northern " Winter Seasonal " zone and the " Summer " zone.

The northern boundary of the " Tropical " zone is a line drawn from the east coast of South America at lat. 10° N. along the parallel of lat. 10° N. to long. 20° W., thence north to lat. 20° N. and thence along the parallel of lat. 20° N. to the west coast of Africa; a line from the east coast of Africa along the parallel of lat. 8° N. to the west coast of the Malay Peninsula, following thence the coast of Malay and Siam to the east coast of Cochin China at lat. 10° N., thence along the parallel of lat. 10° N. to long. 145° E., thence north to lat. 13° N. and thence along the parallel of lat. 13° N. to the west coast of Central America, Saigon to be considered as being on the boundary line of the " Tropical " zone and the " Seasonal Tropical" area (4).

The southern boundary of the " Tropical " zone is a line drawn from the east coast of South America along the Tropic of Capricorn to the west coast of Africa; from the east coast of Africa along the parallel of lat. 20° S. to the west coast of Madagascar, thence along the west and north coast of Madagascar to long. 50° E., thence north to lat. 10° S., thence along the parallel of lat. 10° S. to long. 110° E., thence along a rhumb line to Port Darwin, Australia, thence eastwards along the coast of Australia and Wessel Island to Cape Wessel, thence along the parallel of lat. 11° S. to the west side of Cape York, from the east side of Cape York at lat. 11° S. along the parallel of lat. 11° S. to long. 150° W., thence along a rhumb line to the point lat. 26° S. long. 75° W., and thence along a rhumb line to the west coast of South America at lat. 30° S., Coquimbo, Rio de Janeiro and Port Darwin to be considered as being on the boundary line of the " Tropical " and " Summer " zones.

The following regions are to be included in the " Tropical " zone :—

- (1) *The Suez Canal, the Red Sea and the Gulf of Aden*, from Port Said to the meridian of 45° E., Aden and Berbera to be considered as being on the boundary line of the " Tropical " zone and the " Seasonal Tropical " area 2 (b).
- (2) *The Persian Gulf* to the meridian of 59° E.

The northern boundary of the southern " Winter Seasonal " zone is a line drawn from the east coast of South America along the parallel of lat. 40° S. to long. 56° W., thence along a rhumb line to the point lat. 34° S., long. 50° W., thence along the parallel of lat. 34° S. to the west coast of South Africa; from the east coast of South Africa at lat. 30° S. along a rhumb line to the west coast of Australia at lat. 35° S., thence along the south coast of Australia to Cape Arid, thence along a rhumb line to Cape Grim, Tasmania, thence along the north coast of Tasmania to Eddystone Point, thence along a rhumb line to the west coast of South Island, New Zealand, at long. 170° E., thence along the west, south and east coasts of South Island to Cape Saunders, thence along a rhumb line to the point lat. 33° S. long. 170° W.; and thence along the parallel of lat. 33° S. to the west coast of South America, Valparaiso, Cape Town and Durban to be considered as being on the boundary line of the southern " Seasonal Winter" and " Summer " zones.

Summer Zones.

The remaining areas constitute the " Summer " zones.

Seasonal Areas.

The following areas are Seasonal Tropical areas :—

(1) *In the North Atlantic Ocean*

An area bounded on the north by a line from Cape Catoche in Yucatan to Cape San Antonio in Cuba, by the South Cuban Coast to lat. 20° N. and by the parallel of lat. 20° N. to the point lat. 20° N. long. 20° W.; on the west by the coast of Central America; on the south by the north coast of South America and by parallel of lat. 10° N., and on the east by the meridian of 20° W.

Tropical: 1st November to 15th July.

Summer : 16th July to 31st October.

(2) *Arabian Sea.*

(a) *North of lat. 24° N.*

Karachi is to be considered as being on the boundary line of this area and the seasonal Tropical area (b) below.

Tropical : 1st August to 20th May.

Summer : 21st May to 31st July.

(b) *South of lat. 24° N.*

Tropical: 1st December to 20th May and 16th September to 15th October.

Summer: 21st May to 15th September and 16th October to 30th November.

(3) *Bay of Bengal.*

Tropical: 16th December to 15th April.

Summer : 16th April to 15th December.

(4) *In the China Sea.*

An area bounded on the west and north by the coast of Indo-China and China to Hong Kong, on the east by a rhumb line to the port of Sual (Luzon Island), and by the west coast of the Islands of Luzon, Samar and Leyte to the parallel of 10° N., and on the south by the parallel of lat. 10° N.

Hong Kong and Sual to be considered as being on the boundary of the " Seasonal Tropical " and " Summer " zones.

Tropical: 21st January to 30th April.

Summer : 1st May to 20th January.

(5) *In the North Pacific Ocean.*

(a) An area bounded, on the north by the parallel of lat. 25° N., on the west by the meridian of 160° E., on the south by the parallel of lat. 13° N., and on the east by the meridian of 130° W.

Tropical : 1st April to 31st October.

Summer : 1st November to 31st March.

Status: This is the original version (as it was originally enacted).

- (b) An area bounded on the north and east by the coast of California, Mexico and Central America, on the west by the meridian of 120° W. and by a rhumb line from the point lat. 30° N., long. 120° W., to the point lat. 13° N., long. 105° W., and on the south by the parallel of lat. 13° N.

Tropical: 1st March to 30th June and 1st to 30th November.

Summer : 1st July to 31st October and 1st December to 28th/29th February.

(6) *In the South Pacific Ocean.*

- (a) An area bounded on the north by the parallel of lat. 11° S., on the west by the east coast of Australia, on the south by the parallel of lat. 20° S., and on the east by the meridian of 175° E., together with the Gulf of Carpentaria south of lat. 11° S.

Tropical : 1st April to 30th November.

Summer : 1st December to 31st March.

- (b) An area bounded on the west by the meridian of 150° W., on the south by the parallel of lat. 20° S., and on the north and east by the rhumb line forming the southern boundary of the " Tropical " zone.

Tropical: from 1st March to 30th November.

Summer : from 1st December to 28th/29th February.

The following are " Seasonal Winter " areas :—

Northern " Seasonal Winter " Zone (between North America and Europe).

- (a) In the area within and to the Northwards of the following line :—

A line drawn south from the coast of Greenland at long. 50° W. to lat. 45° N., thence along the parallel of lat. 45° N. to the meridian of 15° W., thence north to lat. 60° N., thence along the parallel of lat. 60° N. to the west coast of Norway, Bergen to be considered as being on the boundary line of this area and area (b) below.

Winter from 16th October to 15th April.

Summer from 16th April to 15th October.

- (b) An area outside area (a) above and north of the parallel of lat. 36° N.

Winter from 1st November to 31st March.

Summer from 1st April to 31st October.

Baltic (bounded by the parallel of latitude of the Skaw).

Winter from 1st November to 31st March.

Summer from 1st April to 31st October.

Mediterranean and Black Sea.

Winter from 16th December to 15th March.

Summer from 16th March to 15th December.

Northern " Seasonal Winter " Zone (between Asia and North America, except Sea of Japan, South of 50° N.).

Winter from 16th October to 15th April.

Summer from 16th April to 15th October.

Sea of Japan between the parallels of lat. 35° N. and 50° N.

Winter from 1st December to 28/29th February.

Summer from 1st March to 30th November.

Southern " Seasonal Winter " Zone.

Status: This is the original version (as it was originally enacted).

Winter from 16th April to 15th October.
Summer from 16th October to 15th April.

Status: This is the original version (as it was originally enacted).

ANNEX III

International Load Line Certificate.

ISSUED under the authority of the Government of.....
under the provisions of the International Load Line Convention,
1930.

Distinctive Number
or Letters.....

Ship

Port of Registry.....

Gross Tonnage

*Freeboard
from deck line.*

Load Line.

Tropical(a).....above (b).

Summer(b) Upper edge of line
through centre of
disc.

Winter(c).....below (b).

Winter in North Atlantic.....(d).....below (b).

Allowance for fresh water for all freeboards.....

Status: This is the original version (as it was originally enacted).

The upper edge of the deck line from which these freeboards are measured is.....inches above the top of the..... deck at side

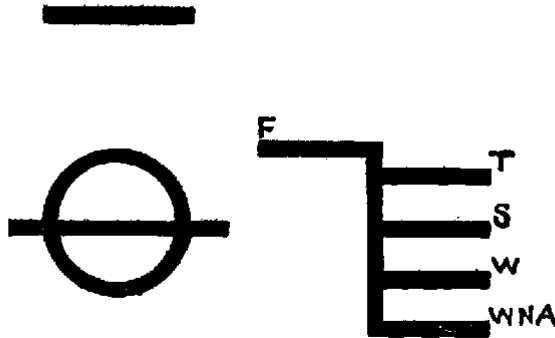

THIS IS TO CERTIFY that this ship has been surveyed and the freeboards and load lines shown above have been assigned in accordance with the Convention.

This certificate remains in force until.....*
Issued at on the
day of

Here follows the signature or seal and the description of the authority issuing the certificate.

* See back.

Note.—Where seagoing steamers navigate a river or inland water, deeper loading is permitted corresponding to the weight of fuel, &c., required for consumption between the point of departure and the open sea.

The provisions of the Convention being fully complied with by this ship, this certificate is renewed till.....
.....

Place Date
Signature or Seal and description of authority.

The provisions of the Convention being fully complied with by this ship, this certificate is renewed till.....
.....

Place Date
Signature or Seal and description of authority.

The provisions of the Convention being fully complied with by this ship, this certificate is renewed till.....
.....

Place Date
Signature or Seal and description of authority.

ANNEX IV

Titles of Load Line Laws and Rules regarded as Equivalent to the British Board of Trade Rules, 1906.

Australia.

Part IV of the Navigation Act, 1912-1920, and Navigation (Load Line) Regulations of the 17th December, 1924.

Belgium.

Loi sur la sécurité des navires (7 décembre 1920).

Chile.

Reglamento para el trazado del disco marcas y linea oficial de carguío de las naves mercantes (Decree No. 1896 of the 12th November, 1919).

Denmark.

Merchant Shipping (Inspection of Ships) Act of the 29th March, 1920, with later amendments.

Rules and Tables of Freeboard for Ships, dated the 30th September, 1909, as amended by Notification of the 25th July, 1918.

France.

Loi du 17 avril 1907. Arrêté du 5 septembre 1908. Décret du 21 septembre 1908. Autre décret du 21 septembre 1908 modifié par le décret du 1er septembre 1925. Décret du 12 mai 1927. Décret du 17 janvier 1928.

Germany.

Vorschriften der See-Berufsgenossenschaft über den Freibord für Dampfer und Segelschiffe, Ausgabe 1908.

Hong Kong.

Merchant Shipping Consolidation Ordinance (No. 10 of 1899), as amended by Ordinances Nos. 31 of 1901, 2 of 1903, 5 of 1905, 16 of 1906, 9 of 1909, and 6 of 1910.

Iceland.

Law No. 58 of the 14th June, 1929, Sections 25-26.

India.

Indian Merchant Shipping Act, 1923.

Italy.

Regole e tavole per assegnazione del " Bordo Libero " approved by decree dated the 1st February, 1929—VII of the Italian Minister for Communications.

Prior to 1929—British Board of Trade Rules, 1906.

Japan.

Ship Load Line Law [Law No. 2 of the 10th year of Taisho (1921)] and the Rules and Regulations relating thereto.

Netherlands.

Decree of the 22nd September, 1909 (Official Journal No. 315).

Netherlands Indies.

Netherlands Decree of the 22nd September, 1909 (Official Journal No. 315).

New Zealand.

British Board of Trade Rules, 1906.

Norway.

Status: This is the original version (as it was originally enacted).

Norwegian Freeboard Rules and Tables of 1909.

Portugal.

Decree No. 11,210 of the 18th July, 1925, and Regulations and Instructions relating thereto.

Spain.

Reglamento para el Trazado del Disco y Marcas de Maxima Carga de los buques mercantes, 1914.

Straits Settlements.

British Board of Trade Rules, 1906.

Sweden.

Rules and Tables of Freeboard approved by decree of the 21st May, 1910.

United Kingdom.

Board of Trade Rules, 1906.

United States of America.

British Board of Trade Rules, 1906.

Union of Soviet Socialist Republics.

Rules and Regulations relating to the Load Lines of seagoing merchant vessels, published by Register of the Union of Soviet Socialist Republics, 1928.

Status: This is the original version (as it was originally enacted).

FINAL ACT OF THE INTERNATIONAL LOAD LINE CONFERENCE, 1930

The Governments of Germany, the Commonwealth of Australia, Belgium, Canada, Chile, Cuba, Denmark, the Free City of Danzig, Spain, the Irish Free State, the United States of America, Finland, France, the United Kingdom of Great Britain and Northern Ireland, Greece, India, Iceland, Italy, Japan, Latvia, Mexico, Norway, New Zealand, Paraguay, the Netherlands, Peru, Poland, Portugal, Sweden and the Union of Soviet Socialist Republics ;

Desiring to promote safety of life and property at sea by establishing in common agreement uniform principles and rules with regard to the limits to which ships on international voyages may be loaded ;

Having decided to participate in an international conference which, upon the invitation of the Government of the United Kingdom of Great Britain and Northern Ireland, was held in London ;

Appointed the following delegations :—

In the course of a series of meetings between the 20th May, 1930, and the 5th July, 1930, a Load Line Convention, dated the 5th July, 1930, was drawn up.

I

The Conference takes note of the following declarations made by the undermentioned delegation :—

The Plenipotentiaries of the United States of America formally declare that the signing of the International Load Line Convention by them, on the part of the United States of America, on this date, is not to be construed to mean that the Government of the United States of America recognizes a regime or entity which signs or accedes to the Convention as the Government of a country when that regime or entity is not recognised by the Government of the United States of America as the Government of that country.

The Plenipotentiaries of the United States of America further declare that the participation of the United States of America in the International Load Line Convention signed on this date does not involve any contractual obligation on the part of the United States of America to a country, represented by a regime or entity which the Government of the United States of America does not recognise as the Government of that country, until such country has a Government recognised by the Government of the United States of America.

II

The Conference also adopts the following recommendations:—

Ships of less than 150 tons gross Engaged on International Voyages.

The Conference recommends that such regulations as may be made by any of the Contracting Governments relating to ships of less than 150 tons gross engaged on international voyages should, so far as practicable and reasonable, be framed in accordance with the principles and rules laid down in this Convention, and should whenever possible be made after consultation and agreement with the Governments of the other countries concerned in such international voyages.

Status: This is the original version (as it was originally enacted).

Strength.

As under the Rules attached to this Convention, ships which comply with the highest standard laid down in the rules of a classification society recognised by the Administration are regarded as having sufficient strength for the minimum freeboards allowed under the rules, the Conference recommends that each Administration should request the Society or Societies which it has recognised to confer from time to time with the Societies recognised by other Administrations, with a view to securing as much uniformity as possible in the application of the standards of strength on which freeboard is based.

Annual Surveys.

The Conference recommends that, if possible, each Administration should make arrangements for the periodical inspections referred to in paragraph (3) (c) of Article 14 to be held at intervals of approximately twelve months so far as concerns the maintenance of the fittings and appliances referred to in Condition B of paragraph 3 of that Article (i.e., the fittings and appliances for the (i) protection of openings, (ii) guard rails, (iii) freeing ports and (iv) means of access to crews' quarters).

Information regarding Damage to Tankers.

The Conference recommends that the Governments of the countries to which tankers belong shall keep records of all structural and deck damage to these ships caused by stress of weather, so that information with regard to these matters may be available.

In faith whereof the undersigned have affixed their signatures to the present Act.

Done in London this fifth day of July, 1930, in a single copy which shall be deposited in the archives of the Government of the United Kingdom of Great Britain and Northern Ireland, which shall transmit certified true copies thereof to all signatory Governments.

THIRD SCHEDULE

Section 22.

RULES WITH RESPECT TO WATERTIGHT DOORS AND OTHER CONTRIVANCES.

- 1 The following contrivances shall be securely closed so as to be watertight before the steamer proceeds to sea, and shall always be kept closed while the steamer is at sea, that is to say:—
- (a) hinged watertight doors below the margin line, which are fitted in main transverse bulkheads dividing cargo between deck spaces;
 - (b) sidescuttles in any between deck space, wherein the sill of any sidescuttle which can be opened is below a line drawn on the side of the steamer parallel to the bulkhead deck and having its lowest point four and a half feet, in addition to two and a half per centum of the breadth of the steamer, above the water at the time when the steamer proceeds to sea;
 - (c) sidescuttles below the margin line which will not be accessible while the steamer is at sea, together with their dead-lights;
 - (d) gangway, cargo and coaling ports below the margin line.

Provided that in fair weather in tropical waters sub-paragraph (b) of this paragraph shall have effect as if " three and a half feet " were substituted for " four and a half feet. "

Status: This is the original version (as it was originally enacted).

- For the purpose of this paragraph, a contrivance shall be deemed to be below the margin line if the sill thereof is below that line, and a sidescuttle mentioned in sub-paragraph (b) of this paragraph shall not be deemed to be closed unless it is locked.
- 2 Every watertight door fitted in a main transverse bulkhead, not being a door mentioned in sub-paragraph (a) of the last foregoing paragraph, shall be kept closed while the steamer is at sea except so far as it is necessary to open it for the working of the steamer, and when open shall be kept ready to be closed forthwith.
- 3 Every portable plate closing an opening in a bulkhead, being an opening which is wholly or partly below the margin line, shall be in place before the steamer proceeds to sea, and no such plate shall be removed at sea except in case of urgent necessity, and in replacing any such plate all reasonable precautions shall be taken to ensure that the joints are watertight.
- 4 The cover and valve of every ash-shoot, rubbish-shoot or other similar contrivance, having its inboard opening below the margin line, shall be kept securely closed when the contrivance is not in use.
- 5 The opening and closing of all such watertight doors and other contrivances as are mentioned in sub-paragraphs (a), (b) and (c) of paragraph 1 and paragraphs 2 and 4 of this Schedule, and of the closing mechanism of all scuppers having their inboard opening below the margin line, shall be practised once a week and also before the steamer proceeds to sea on any voyage which is likely to last more than a week:
- Provided that while the steamer is at sea—
- (a) the opening and closing of all such watertight doors, which are in use and are hinged or operated by power, shall be practised daily;
 - (b) nothing in this paragraph shall be taken to authorise the opening of any watertight door or other contrivance which is required by paragraph 1 of this Schedule to be kept closed.
- 6 Every valve, the closing of which is necessary to make any compartment watertight, and every watertight door in a main transverse bulkhead and the mechanism and indicators connected therewith, shall be inspected at least once a week.
- 7 A record shall be entered in the official logbook—
- (a) of the time of opening and closing every watertight door operated by power which is fitted between bunkers in the between decks below the bulkhead deck, every such portable plate as is mentioned in paragraph 3 of this Schedule and every such watertight door, and other contrivance as is mentioned in paragraph 1 of this Schedule; and
 - (b) of every occasion on which the opening and closing of watertight doors and other contrivances is practised on board the ship in pursuance of this Schedule ; and
 - (c) of every occasion on which watertight doors and other contrivances have been inspected in pursuance of this Schedule.
- 8 In this Schedule the expressions " bulkhead deck " and " margin line " have the same meaning as in the construction regulations.

Status: This is the original version (as it was originally enacted).

FOURTH SCHEDULE

ENACTMENTS REPEALED.

Section 39.

PART I

ENACTMENTS REPEALED AS FROM COMMENCEMENT OF PART I.

Session and Chapter.	Short Title.	Extent of repeal.
57 & 58 Vict. c. 60.	The Merchant Shipping Act, 1894.	In section two hundred and seventy-two, paragraph (d) of subsection (3) and paragraph (e) of subsection (4) ; subsection (2) of section two hundred and eighty five; subsection (2) of section four hundred and twenty-seven ; section four hundred and thirty-four.
59 & 60 Vict. c. 12.	The Derelict Vessels (Report) Act, 1896.	The whole Act.

Section 67.

PART II

ENACTMENTS REPEALED AS FROM THE APPOINTED DAY.

Session and Chapter.	Short title.	Extent of repeal.
57 & 58 Vict. c. 60.	The Merchant Shipping Act, 1894.	Sections four hundred and thirty-seven to four hundred and forty-five.
6 Edw. 7. c. 48	The Merchant Shipping Act, 1906.	Sections one, seven, eight and ten.

Section 74.

PART III

ENACTMENTS REPEALED AS FROM PASSING OF ACT.

Session and Chapter.	Short title.	Extent of repeal.
4 & 5Geo. 5. c. 50.	The Merchant Shipping (Convention) Act, 1914.	The whole Act.

Status: This is the original version (as it was originally enacted).

Session and Chapter.	Short title.	Extent of repeal.
9 & 10 Geo. 5. c. 38.	The Merchant Shipping (Wireless Telegraphy) Act, 1919.	The proviso to subsection (2) of section one; in subsection (4) of section one the words " or a wireless telegraphy " inspector" and the words " or inspector" in both places where those words occur; in subsection (5) of section one the words " or by the Merchant " Shipping (Convention) " Act, 1914"; in subsection (2) of section three the words from " and wireless telegraphy inspector" to the end of that subsection.