

1969 No. 216

CIVIL AVIATION

**The Rules of the Air and Air Traffic Control
Regulations 1969**

Made - - - 20th February 1969

Coming into Operation 3rd March 1969

The Board of Trade, in exercise of their powers under Article 59(1) of the Air Navigation Order 1966(a), as amended (b), (hereinafter referred to as "the Order") and of all other powers enabling them in that behalf, hereby make the following Regulations.

1. These Regulations may be cited as the Rules of the Air and Air Traffic Control Regulations 1969, and shall come into operation on 3rd March 1969.

2. The Rules set forth in the Schedule hereto are hereby prescribed as the Rules of the Air and Air Traffic Control.

3.—(1) Subject to the following provisions of this Regulation, the following Regulations are hereby revoked, that is to say :

The Rules of the Air and Air Traffic Control Regulations 1966(c).

The Rules of the Air and Air Traffic Control (Amendment) Regulations 1966(d).

The Rules of the Air and Air Traffic Control (Second Amendment) Regulations 1967(e).

The Rules of the Air and Air Traffic Control (Third Amendment) Regulations 1967(f).

The Rules of the Air and Air Traffic Control (Fourth Amendment) Regulations 1967(g).

The Rules of the Air and Air Traffic Control (Fifth Amendment) Regulations 1967(h).

The Rules of the Air and Air Traffic Control (Sixth Amendment) Regulations 1968(i).

The Rules of the Air and Air Traffic Control (Seventh Amendment) Regulations 1968(j).

(2) (a) Section 38(2) of the Interpretation Act 1889(k) (which relates to the effect of repeals), shall apply to these Regulations as if these Regulations were an Act of Parliament and as if the Regulations revoked by paragraph (1) of this Regulation were Acts of Parliament thereby repealed.

(a) S.I. 1966/1184 (1966 III, p.3073).

(c) S.I. 1966/1257 (1966 III, p.3431).

(e) S.I. 1967/533 (1967 I, p.1738).

(g) S.I. 1967/1081 (1967 II, p.3213).

(i) S.I. 1968/1837. (1968 III, p.4846).

(k) 1889 c.63.

(b) There is no relevant amending instrument.

(d) S.I. 1966/1377 (1966 III, p.3702).

(f) S.I. 1967/643 (1967 I, p.1983).

(h) S.I. 1967/1556 (1967 III, p.4321).

(j) S.I. 1968/2070 (1968 III, p.5606).

(b) These Regulations shall apply to or in relation to any licence or other document issued or granted under any Regulation revoked by these Regulations, as they apply to a licence or other document issued or granted under these Regulations.

(c) Any licence or other document issued or granted under any Regulations revoked by these Regulations in force at the date of the coming into operation of these Regulations shall, subject to the provisions of Article 56 of the Order, remain in force and shall have effect for the purposes of these Regulations as if it had been issued or granted under the corresponding provisions thereof:

Provided that any such document which is expressed to remain in force for a definite period shall remain in force, unless renewed, only until the expiration of that period.

Robert Burns,
A Second Secretary
of the Board of Trade.

20th February 1969.

THE SCHEDULE
THE RULES OF THE AIR AND AIR TRAFFIC CONTROL
ARRANGEMENT OF RULES

	Rules
Section I INTERPRETATION	1
Section II GENERAL	2 to 7
Section III LIGHTS AND OTHER SIGNALS TO BE SHOWN OR MADE BY AIRCRAFT	8 to 16
Section IV GENERAL FLIGHT RULES	17 to 23
Section V VISUAL FLIGHT RULES	24
Section VI INSTRUMENT FLIGHT RULES	25 to 29
Section VII AERODROME TRAFFIC RULES	30 to 37
Section VIII SPECIAL RULES FOR LOW-LEVEL CROSS-CHANNEL AIR TRAFFIC	38
Section IX AERODROME SIGNALS AND MARKINGS: VISUAL AND AURAL SIGNALS	39 to 47
Section X GROUND LIGHTING	48 to 54
Section XI AIR TRAFFIC CONTROL	55 to 59

SECTION I

INTERPRETATION

1.—(1) In these Rules, unless the context otherwise requires—

“Aerodrome traffic zone” in relation to any aerodrome means the airspace extending from the aerodrome to a height of 2,000 feet above the level of the aerodrome and within a distance of 3,000 yards of its boundaries except any part of that airspace which is within the aerodrome traffic zone of another aerodrome which is notified for the purposes of these Rules as being the controlling aerodrome.

“Air traffic control clearance” means authorisation by an air traffic control unit for an aircraft to proceed under conditions specified by that unit.

“Anti-collision light” means a flashing red light showing in all directions for the purpose of enabling the aircraft to be more readily detected by the pilots of distant aircraft.

“Apron” means the part of an aerodrome provided for the stationing of aircraft for the embarkation and disembarkation of passengers, the loading and unloading of cargo and for parking.

“Cloud ceiling” in relation to an aerodrome means the distance measured vertically from the notified elevation of that aerodrome to the lowest part of any cloud visible from the aerodrome which is sufficient to obscure more than one half of the sky so visible.

“Flight visibility” means the visibility forward from the flight deck of an aircraft in flight.

“Ground visibility” means the horizontal visibility at ground level.

“IFR flight” means a flight conducted in accordance with the Instrument Flight Rules in Section VI of these Rules.

“Instrument Meteorological Conditions” means weather precluding flight in compliance with the Visual Flight Rules.

“Manœuvring area” means the part of an aerodrome provided for the take-off and landing of aircraft and for the movement of aircraft on the surface, excluding the apron and any part of the aerodrome provided for the maintenance of aircraft.

“Night” means the time between half an hour after sunset and half an hour before sunrise, sunset and sunrise being determined at surface level.

“The Order” means the Air Navigation Order 1966, as amended.

“Runway” means an area, whether or not paved, which is provided for the take-off or landing run of aircraft.

“VFR Flight” means a flight conducted in accordance with the Visual Flight Rules in Section V of these Rules.

“Visual Meteorological Conditions” means weather permitting flight in accordance with the Visual Flight Rules.

(2) Subject to the provisions of paragraph (1) of this Rule expressions used in these Rules shall, unless the context otherwise requires, have the same respective meanings as in the Order.

(3) The Interpretation Act 1889 applies for the purpose of the interpretation of these Rules as it applies for the purpose of the interpretation of an Act of Parliament.

SECTION II

GENERAL

Application of Rules to aircraft

2. These Rules, in so far as they are applicable in relation to aircraft, shall, subject to the provisions of Rule 30 of these Rules, apply in relation to—

- (a) all aircraft within the United Kingdom; and
- (b) all aircraft registered in the United Kingdom, wherever they may be.

Misuse of Signals and Markings

3.—(1) A signal or marking to which a meaning is given by these Rules, or which is required by these Rules to be used in circumstances or for a purpose therein specified, shall not be used except with that meaning, or for that purpose.

(2) A person in an aircraft or on an aerodrome or at any place at which an aircraft is taking off or landing shall not make any signal which may be confused with a signal specified in these Rules, and, except with lawful authority, shall not make any signal which he knows or ought reasonably to know to be a signal in use for signalling to or from any of Her Majesty's naval, military or air force aircraft.

Reporting hazardous conditions

4. The commander of an aircraft shall, on meeting with hazardous conditions in the course of a flight, or as soon as possible thereafter, send to the appropriate air traffic control unit by the quickest means available information containing such particulars of the hazardous conditions as may be pertinent to the safety of other aircraft.

Low Flying

5.—(1) Subject to the provisions of paragraphs (2) and (3) of this Rule:

(a) An aircraft other than a helicopter shall not fly over any congested area of a city, town or settlement below—

(i) such height as would enable the aircraft to alight clear of the area and without danger to persons or property on the surface, in the event of failure of a power unit; or

(ii) a height of 1,500 feet above the highest fixed object within 2,000 feet of the aircraft, whichever is the higher.

(b) A helicopter shall not fly below such height as would enable it to alight without danger to persons or property on the surface, in the event of failure of a power unit.

(c) Except with the permission in writing of the Board and in accordance with any conditions therein specified a helicopter shall not fly—

(i) over a congested area of a city, town or settlement below a height of 1,500 feet above the highest fixed object within 2,000 feet of the helicopter; or

(ii) over the area specified, below such height as would enable it to alight clear of the area in the event of failure of a power unit, that is to say the area bounded by straight lines joining the following points:

Kew Bridge (51°29'11"N 00°17'10"W)

The Eastern extremity of Brent Reservoir (51°34'18"N 00°13'55"W)

Gospel Oak Station (B.R.) (51°33'18"N 00°08'58"W)

The South East corner of Springfield Park (51°34'09"N 00°03'17"W)

Bromley (Bow) Station (B.R.) (51°31'20"N 00°00'36"W)

The South West corner of Hither Green (51°26'44"N 00°00'38"W)

Herne Hill Station (B.R.) (51°26'32"N 00°06'04"W)

Wimbledon Station (B.R.) (51°25'17"N 00°12'15"W)

The North West corner of Castelnau Reservoir (51°28'52"N 00°14'02"W)

Kew Bridge (51°29'11"N 00°17'10"W)

excluding so much of the bed of the river Thames as lies within that area between the ordinary high water marks on each of its banks.

(d) An aircraft shall not fly—

(i) over, or within 1,000 yards of, any assembly in the open air of more than 1,000 persons assembled for the purpose of witnessing or participating in any organised event, except with the permission in writing of the Board and in accordance with any conditions therein specified and with the consent in writing of the organisers of the event; or

(ii) below such height as would enable it to alight clear of the assembly in the event of the failure of a power unit:

Provided that where a person is charged with an offence under the Order by reason of a contravention of this sub-paragraph, it shall be a good defence to prove that the flight of the aircraft over, or within 1,000 yards of, the assembly was made at a reasonable height and for a reason not connected with the assembly or with the event which was the occasion for the assembly.

(e) An aircraft shall not fly closer than 500 feet to any person, vessel, vehicle or structure.

(2)(a) The provisions of paragraphs (1)(a)(ii) and (1)(c)(i) of this Rule shall not apply to an aircraft flying—

(i) on a route notified for the purposes of this Rule, or

(ii) on a special VFR flight as defined in Rule 24 of these Rules in accordance with instructions given for the purposes of that Rule by the appropriate air traffic control unit.

(b) Paragraphs (1)(d) and (e) of this Rule shall not apply to an aircraft in the service of the police authority for any area of the United Kingdom.

(c) Paragraphs (1)(d) and (e) of this Rule shall not apply to the flight of an aircraft over or within 1,000 yards of an assembly of persons gathered for the purpose of witnessing an event which consists wholly or principally of an aircraft race or contest or an exhibition of flying, if the aircraft is taking part in such race, contest or exhibition or is engaged on a flight arranged by, or made with the consent in writing of, the organisers of the event.

(d) Paragraph (1)(e) of this Rule shall not apply to:

(i) any aircraft while it is landing or taking off in accordance with normal aviation practice;

(ii) any glider while it is hill-soaring.

(3) Nothing in this Rule shall prohibit any aircraft from—

(a) taking off, landing or practising approaches to landing, or

(b) flying for the purpose of checking navigational aids or procedures in accordance with normal aviation practice at a Government or licensed aerodrome in the United Kingdom or at any aerodrome in any other State, or

(c) flying in such a manner as may be necessary for the purpose of saving life:

Provided that in the case of practising approaches to landing as aforesaid such practising is confined to the airspace customarily used by aircraft when landing or taking off in accordance with normal aviation practice at the aerodrome concerned.

(4) Nothing in this Rule shall apply to any captive balloon or kite.

Simulated instrument flight

6. An aircraft shall not be flown in simulated instrument flight conditions unless—

(a) the aircraft is fitted with dual controls which are functioning properly;

(b) an additional pilot (in this Rule called “a safety pilot”) is carried in a second control seat of the aircraft for the purpose of rendering such assistance as may be necessary to the pilot flying the aircraft; and

(c) if the safety pilot’s field of vision is not adequate both forward and to each side of the aircraft, a third person, being a competent observer, occupies a position in the aircraft from which his field of vision makes good the deficiencies in that of the safety pilot, and from which he can readily communicate with the safety pilot.

For the purposes of this Rule the expression “simulated instrument flight” means a flight during which mechanical or optical devices are used in order to reduce the field of vision or the range of visibility from the cockpit of the aircraft.

Practice Instrument Approaches

7. Within the United Kingdom an aircraft shall not carry out instrument approach practice when flying in Visual Meteorological Conditions unless—

(a) the appropriate air traffic control unit has previously been informed that the flight is to be made for the purpose of instrument approach practice; and

(b) if the flight is not being carried out in simulated instrument flight conditions, a competent observer is carried in such a position in the aircraft that he has an adequate field of vision and can readily communicate with the pilot flying the aircraft.

SECTION III

LIGHTS AND OTHER SIGNALS TO BE SHOWN OR MADE BY AIRCRAFT

General

8.—(1) For the purposes of this Section of these Rules the horizontal plane of a light shown by an aircraft means the plane which would be the horizontal plane passing through the source of that light, if the aircraft were in level flight.

(2) Where by reason of the physical construction of an aircraft it is necessary to fit more than one lamp in order to show a light required by this Section of these Rules,

the lamps shall be so fitted and constructed that, so far as is reasonably practicable, not more than one such lamp is visible from any one point outside the aircraft.

(3) Where in these Rules a light is required to show through specified angles in the horizontal plane, the lamps giving such light shall be so constructed and fitted that the light is visible from any point in any vertical plane within those angles throughout angles of 90° above and below the horizontal plane, but, so far as is reasonably practicable, through no greater angle, either in the horizontal plane or the vertical plane.

(4) Where in these Rules a light is required to show in all directions, the lamps giving such light shall be so constructed and fitted that, so far as is reasonably practicable, the light is visible from any point in the horizontal plane and on any vertical plane passing through the source of that light.

Display of Lights by Aircraft

9.—(1) By night an aircraft shall display such of the lights specified in these Rules as may be appropriate to the circumstances of the case, and shall not display any other lights which might obscure or otherwise impair the visibility of, or be mistaken for, such lights:

Provided that nothing in this paragraph shall prevent the display of an anti-collision light.

(2) A flying machine on a land aerodrome in the United Kingdom at which aircraft normally land or take off at night shall, unless it is stationary on the apron or a part of the aerodrome provided for the maintenance of aircraft, display by night either the lights which it would be required to display if it were flying, or the lights specified in Rule 11(2)(a) or 11(2)(c) of these Rules.

Failure of Navigation Lights

10. In the United Kingdom, in the event of the failure of any light which is required by these Rules to be displayed in flight, if the light cannot be immediately repaired or replaced the aircraft shall land as soon as in the opinion of the commander of the aircraft it can safely do so, unless authorised by the appropriate air traffic control unit to continue its flight.

Flying Machines

11.—(1) A flying machine when flying at night shall display lights as follows:

- (a) in the case of a flying machine registered in the United Kingdom having a maximum total weight authorised of more than 12,500 lb. the system of lights specified in paragraph 2(b) of this Rule;
- (b) in the case of a flying machine registered in the United Kingdom having a maximum total weight authorised of 12,500 lb. or less, any one of the following systems of lights—
 - that specified in paragraph 2(a) of this Rule; or that specified in paragraph 2(b); or
 - that specified in paragraph 2(d), excluding sub-paragraph (ii);
- (c) in the case of any other flying machine one of the systems of lights specified in paragraph 2) of this Rule.

(2) The systems of lights referred to in paragraph (1) of this Rule are as follows:

- (a) (i) a green light of at least five candles showing to the starboard side through an angle of 110° from dead ahead in the horizontal plane;
- (ii) a red light of at least five candles showing to the port side through an angle of 110° from dead ahead in the horizontal plane; and
- (iii) a white light of at least three candles showing through angles of 70° from dead astern to each side in the horizontal plane, all being steady lights;
- (b) (i) the lights specified in sub-paragraph (a) of this paragraph; and
- (ii) an anti-collision light;

- (c) the lights specified in sub-paragraph (a) of this paragraph, but all being flashing lights flashing together;
- (d) the lights specified in sub-paragraph (a) of this paragraph, but all being flashing lights flashing together in alternation with one or both of the following:
 - (i) a flashing white light of at least twenty candles showing in all directions;
 - (ii) a flashing red light of at least twenty candles showing through angles of 70° from dead astern to each side in the horizontal plane.

(3) If the lamp showing either the red or the green light specified in paragraph (2)(a) of this Rule is fitted more than 6 feet from the wing tip, a lamp may, notwithstanding the provisions of Rule 9(1) of these Rules, be fitted at the wing tip to indicate its position, showing a steady light of the same colour through the same angle.

Gliders

12. A glider while flying at night shall display either a steady red light of at least five candles, showing in all directions, or lights in accordance with Rule 11(2) and (3) of these Rules.

Free Balloons

13. A free balloon while flying at night shall display a steady red light, of at least five candles, showing in all directions, suspended not less than 15 feet and not more than 30 feet below the basket, or if there is no basket, below the lowest part of the balloon.

Captive Balloons and Kites

14.—(1) A captive balloon or kite while flying at night at a height exceeding 200 feet above the surface shall display lights as follows:

- (a) a group of two steady lights consisting of a white light placed 12 feet above a red light, both being of at least five candles and showing in all directions, the white light being placed not less than 15 feet or more than 30 feet below the basket, or, if there is no basket, below the lowest part of the balloon or kite;
- (b) on the mooring cable, at intervals of not more than 1,000 feet measured from the group of lights referred to in sub-paragraph (a) of this paragraph, groups of two lights of the colour and power and in the relative positions specified in that sub-paragraph, and, if the lowest group of lights is obscured by cloud, an additional group below the cloud base; and
- (c) on the surface, a group of three flashing lights arranged in a horizontal plane at the apexes of a triangle, approximately equilateral, each side of which measures at least 80 feet; one side of the triangle shall be approximately at right angles to the horizontal projection of the cable and shall be delimited by two red lights; the third light shall be a green light so placed that the triangle encloses the object on the surface to which the balloon or kite is moored.

(2) A captive balloon while flying by day at a height exceeding 200 feet above the surface shall have attached to its mooring cable at intervals of not more than 600 feet measured from the basket, or, if there is no basket, from the lowest part of the balloon, tubular streamers not less than 16 inches in diameter and 6 feet in length, and marked with alternate bands of red and white 20 inches wide.

(3) A kite flown in the circumstances referred to in paragraph (2) of this Rule shall have attached to its mooring cable either:

- (a) tubular streamers as specified in paragraph (2) of this Rule, or
- (b) at intervals of not more than 300 feet measured from the lowest part of the kite, streamers of not less than 32 inches long and one foot wide at their widest part and marked with alternate bands of red and white 4 inches wide.

Airships

15.—(1) Except as provided in paragraph (2) of this Rule, an airship while flying at night shall display the following steady lights:

- (a) a white light of at least five candles showing through angles of 110° from dead ahead to each side in the horizontal plane;

- (b) a green light of at least five candles showing to the starboard side through an angle of 110° from dead ahead in the horizontal plane;
- (c) a red light of at least five candles showing to the port side through an angle of 110° from dead ahead in the horizontal plane; and
- (d) a white light of at least five candles showing through angles of 70° from dead astern to each side in the horizontal plane.

(2) An airship while flying at night shall display, if it is not under command, or has voluntarily stopped its engines, or is being towed, the following steady lights:

- (a) the white lights referred to in paragraph (1)(a) and (d) of this Rule;
- (b) two red lights, each of at least five candles and showing in all directions suspended below the control car so that one is at least 12 feet above the other and at least 25 feet below the control car; and
- (c) if the airship is making way but not otherwise, the green and red lights referred to in paragraph (1)(b) and (c) of this Rule:

Provided that an airship while picking up its moorings, notwithstanding that it is not under command, shall display only the lights specified in paragraph (1) of this Rule.

(3) An airship, while moored within the United Kingdom by night, shall display the following lights:

- (a) when moored to a mooring mast, at or near the rear a white light of at least five candles showing in all directions;
- (b) when moored otherwise than to a mooring mast:
 - (i) a white light of at least five candles showing through angles of 110° from dead ahead to each side in the horizontal plane; and
 - (ii) a white light of at least five candles showing through angles of 70° from dead astern to each side in the horizontal plane.

(4) An airship while flying by day, if it is not under command, or has voluntarily stopped its engines, or is being towed, shall display two black balls suspended below the control car so that one is at least 12 feet above the other and at least 25 feet below the control car.

(5) For the purpose of this Rule:

- (a) an airship shall be deemed not to be under command when it is unable to execute a manoeuvre which it may be required to execute by or under these Rules;
- (b) an airship shall be deemed to be making way when it is not moored and is in motion relative to the air.

Secondary Surveillance Radar Transponders

16. Every aircraft (not being a glider), when flying at or above flight level 250 within such airspace as may be notified as an Upper Information Region of the United Kingdom shall be provided with radio apparatus of a design approved by the Board capable of replying to an interrogation from secondary surveillance radar units on the surface and set in accordance with such instructions as may be given to the aircraft by the appropriate air traffic control unit.

SECTION IV

GENERAL FLIGHT RULES

Weather reports and forecasts

17.—(1) Immediately before an aircraft flies the commander of the aircraft shall examine the current reports and forecasts of the weather conditions on the proposed flight path, being reports and forecasts which it is reasonably practicable for him to obtain, in order to determine whether Instrument Meteorological Conditions prevail or are likely to prevail during any part of the flight.

(2) An aircraft which is unable to communicate by radio with an air traffic control unit at the aerodrome of destination shall not begin a flight to an aerodrome within a control zone if the information which it is reasonably practicable for the commander of the aircraft to obtain indicates that it will arrive at that aerodrome when the ground visibility is less than five nautical miles or the cloud ceiling is less than 1,500 feet, unless the commander of the aircraft has obtained from an air traffic control unit at that aerodrome permission to enter the aerodrome traffic zone.

Rules for avoiding aerial collisions

18.—(1) General

- (a) Notwithstanding that the flight is being made with air traffic control clearance it shall remain the duty of the commander of an aircraft to take all possible measures to ensure that his aircraft does not collide with any other aircraft.
- (b) An aircraft shall not be flown in such proximity to other aircraft as to create a danger of collision.
- (c) Aircraft shall not fly in formation unless the commanders of the aircraft have agreed to do so.
- (d) An aircraft which is obliged by these Rules to give way to another aircraft shall avoid passing over or under the other aircraft, or crossing ahead of it, unless passing well clear of it.
- (e) An aircraft which has the right-of-way under this Rule shall maintain its course and speed.
- (f) For the purposes of this Rule a glider and a flying machine which is towing it shall be considered to be a single aircraft under the command of the commander of the towing flying machine.

(2) Converging

- (a) Subject to the provisions of paragraphs (3) and (4) of this Rule, an aircraft in the air shall give way to other converging aircraft as follows:
 - (i) flying machines shall give way to airships, gliders and balloons;
 - (ii) airships shall give way to gliders and balloons;
 - (iii) gliders shall give way to balloons.
- (b) Subject to the provisions of sub-paragraph (a) of this paragraph, when two aircraft are converging in the air at approximately the same altitude, the aircraft which has the other on its right shall give way:

Provided that mechanically driven aircraft shall give way to aircraft which are towing other aircraft or objects.

(3) Approaching Head-on

When two aircraft are approaching head-on or approximately so in the air and there is danger of collision, each shall alter its course to the right.

(4) Overtaking

An aircraft which is being overtaken in the air shall have the right-of-way and the overtaking aircraft, whether climbing, descending or in horizontal flight, shall keep out of the way of the other aircraft by altering course to the right, and shall not cease to keep out of the way of the other aircraft until that other aircraft has been passed and is clear, notwithstanding any change in the relative positions of the two aircraft:

Provided that a glider overtaking another glider in the United Kingdom may alter its course to the right or to the left.

(5) Landing

An aircraft while landing or on final approach to land shall have the right-of-way over other aircraft in flight or on the ground or water.

(6) Two or more aircraft landing

In the case of two or more flying machines or gliders approaching any place for the purpose of landing, the aircraft at the lower altitude shall have the right-of-way, but

it shall not cut in front of another aircraft which is on final approach to land or overtake that aircraft:

Provided that:

- (a) when an air traffic control unit has communicated to any aircraft an order of priority for landing, the aircraft shall approach to land in that order, and
- (b) when the commander of an aircraft is aware that another aircraft is making an emergency landing, he shall give way to that aircraft, and at night, notwithstanding that he may have received permission to land, shall not attempt to land until he has received further permission to do so.

Aerobatic Manœuvres

19. An aircraft shall not carry out any aerobatic manœuvre—

- (a) over the congested area of any city, town or settlement; or
- (b) within controlled airspace except with the consent of the appropriate air traffic control unit.

Right-hand Traffic Rule

20. An aircraft which is flying within the United Kingdom in sight of the ground and following a road, railway, canal or coastline, or any other line of landmarks, shall keep such line of landmarks on its left:

Provided that this Rule shall not apply to a helicopter following the Motorway M4 on a route from West Drayton to Osterley Lock.

Notification of Arrival

21.—(1) The commander of an aircraft entering or leaving the United Kingdom on any flight for which a flight plan has been submitted shall take all reasonable steps to ensure upon landing that notice of the arrival of the aircraft is given to the aerodrome of departure:

Provided that notice of arrival need not be given upon completion of a flight between the United Kingdom and the Republic of Ireland or any other country in Europe or in or bordering on the Mediterranean Sea, unless an air traffic control unit at the aerodrome of departure has required it to be given, or unless the aircraft lands at an aerodrome other than its intended destination when it began the flight.

(2) The commander of an aircraft who has caused notice of its intended arrival at any aerodrome to be given to the air traffic control unit or other authority at that aerodrome shall ensure that the air traffic control unit or other authority at that aerodrome is informed as quickly as possible of any change of intended destination and any estimated delay in arrival of 45 minutes or more.

Flight in Notified Airspace

22. In relation to flights in Visual Meteorological Conditions in controlled airspace notified for the purposes of this Rule, the commander of an aircraft shall comply with Rules 28 and 29 of these Rules as if the flights were IFR flights:

Provided that the commander of the aircraft shall not elect to continue the flight in compliance with the Visual Flight Rules for the purposes of Rule 28(3).

Choice of VFR or IFR

23. Subject to the provisions of Rule 22 of these Rules an aircraft shall always be flown in accordance with the Visual Flight Rules or the Instrument Flight Rules:

Provided that in the United Kingdom an aircraft flying at night shall be flown in accordance with the Instrument Flight Rules, or, in a control zone, in accordance with the Instrument Flight Rules or the provisions of the proviso to Rule 24(b) of these Rules.

SECTION V

VISUAL FLIGHT RULES

24. The Visual Flight Rules shall be as follows:

(a) *Outside controlled airspace*

An aircraft flying outside controlled airspace shall remain at least one nautical mile horizontally and 1,000 feet vertically away from cloud and in a flight visibility of at least five nautical miles:

Provided that at or below 3,000 feet above mean sea level this paragraph shall be deemed to be complied with if the aircraft is flown clear of cloud and in sight of the surface.

(b) *Within controlled airspace*

An aircraft flying within controlled airspace shall remain at least one nautical mile horizontally and 1,000 feet vertically away from cloud and in a flight visibility of at least five nautical miles:

Provided that in a control zone, in the case of a special VFR flight, the aircraft shall be flown in accordance with any instructions given by the appropriate air traffic control unit.

For the purposes of this Rule "special VFR flight" means a flight made in Instrument Meteorological Conditions or at night or in a control zone notified for the purposes of Rule 22 of these Rules, in respect of which the appropriate air traffic control unit has given permission for the flight to be made in accordance with special instructions given by that unit instead of in accordance with the Instrument Flight Rules.

SECTION VI

INSTRUMENT FLIGHT RULES

25. The Instrument Flight Rules shall be as follows:

(a) *Outside controlled airspace*

In relation to flights outside controlled airspace Rules 26 and 27 of these Rules shall apply.

(b) *Within controlled airspace*

In relation to flights within controlled airspace Rules 26, 28 and 29 of these Rules shall apply.

Minimum Height

26. Without prejudice to the provisions of Rule 5 of these Rules, in order to comply with the Instrument Flight Rules an aircraft shall not fly at a height of less than 1,000 feet above the highest obstacle within a distance of five nautical miles of the aircraft unless flying on a route notified for the purposes of this Rule, or otherwise authorised by the competent authority or unless it is necessary to do so in order to take off or land.

Quadrantal Rule and Semi-Circular Rule

27. In order to comply with the Instrument Flight Rules an aircraft when in level flight above 3,000 feet above mean sea level outside controlled airspace shall be flown at a level appropriate to its magnetic track, in accordance with the appropriate table set forth in this Rule. The level of flight shall be measured by an altimeter set according to the system notified, or in the case of flight over a country other than the United Kingdom, otherwise published by the competent authority, in relation to the area over which the aircraft is flying:

Provided that an aircraft may be flown at a level other than the level required by this Rule if it is flying in conformity with instructions given by an air traffic control unit or in accordance with holding procedures notified in relation to an aerodrome.

TABLE I—*Flights at levels below 25,000 feet*

<i>Magnetic Track</i>			<i>Cruising Level</i>
Less than 90°	Odd thousands of feet.
90° but less than 180°	Odd thousands of feet + 500 feet.
180° but less than 270°	Even thousands of feet.
270° but less than 360°	Even thousands of feet + 500 feet.

TABLE II—*Flights at levels of 25,000 feet and above*

<i>Magnetic Track</i>			<i>Cruising Level</i>
Less than 180°	25,000 feet.
			27,000 feet.
180° but less than 360°	29,000 feet or higher levels at intervals of 4,000 feet.
			26,000 feet.
			28,000 feet.
			31,000 feet or higher levels at intervals of 4,000 feet.

Flight Plan and Air Traffic Control Clearance

28.—(1) In order to comply with the Instrument Flight Rules, before an aircraft either takes off from a point within any controlled airspace or enters any controlled airspace the commander of the aircraft shall cause a flight plan to be communicated to the appropriate air traffic control unit and shall obtain an air traffic control clearance based on such flight plan.

(2) The flight plan shall contain such particulars of the intended flight as may be necessary to enable the air traffic control unit to issue an air traffic control clearance, or for search and rescue purposes.

(3) The commander of the aircraft shall fly in conformity with

- (a) the air traffic control clearance issued for the flight, as amended by any further instructions given by an air traffic control unit; and
- (b) the holding and instrument approach procedures notified in relation to the aerodrome of destination, unless he is otherwise authorised by the air traffic control unit there:

Provided that he shall not be required to comply with the foregoing provisions of this paragraph if:

- (i) he is able to fly in uninterrupted Visual Meteorological Conditions for so long as he remains in controlled airspace, and
- (ii) he has informed the appropriate air traffic control unit of his intention to continue the flight in compliance with Visual Flight Rules and has requested that unit to cancel his flight plan.

(4) If for the purpose of avoiding immediate danger any departure is made from the provisions of paragraph (3) of this Rule (as is permitted by Article 59(3) of the Order) the commander of the aircraft shall, in addition to causing particulars to be given in accordance with Article 59(4) of the Order, as soon as possible inform the appropriate air traffic control unit of the deviation.

(5) The commander of the aircraft after it has flown in controlled airspace shall, unless he has requested the appropriate air traffic control unit to cancel his flight plan, forthwith inform that unit when the aircraft lands within or leaves the controlled airspace.

Position Reports

29. In order to comply with the Instrument Flight Rules the commander of an aircraft in IFR flight who flies in or is intending to enter controlled airspace shall report to the appropriate air traffic control unit the time, and the position and altitude of the aircraft at such reporting points or at such intervals of time as may be notified for this purpose or as may be directed by the air traffic control unit.

SECTION VII

AERODROME TRAFFIC RULES

Application of Aerodrome Traffic Rules

30. The Rules in this Section of these Rules which are expressed to apply to flying machines shall also be observed, so far as is practicable, in relation to all other aircraft.

Visual Signals

31. The commander of a flying machine on, or in the traffic zone of, an aerodrome shall observe such visual signals as may be displayed at, or directed to him from, the aerodrome by the authority of the person in charge of the aerodrome and shall obey any instructions which may be given to him by means of such signals:

Provided that he shall not be required to obey the signals referred to in Rule 45 of these Rules (Marshalling Signals) if in his opinion it is inadvisable to do so in the interests of safety.

Access to and movement on the Manœuvring Area and other parts of the aerodrome used by aircraft

32.—(1) A person or vehicle shall not go on to any part of an aerodrome provided for the use of aircraft and under the control of the person in charge of the aerodrome without the permission of the person in charge of the aerodrome, and except in accordance with any conditions subject to which that permission may have been granted.

(2) A vehicle or person shall not go or move on the manœuvring area of an aerodrome having an air traffic control unit without the permission of that unit, and except in accordance with any conditions subject to which that permission may have been granted.

(3) Any permission granted for the purposes of this Rule may be granted either in respect of persons or vehicles generally, or in respect of any particular person or vehicle or any class of person or vehicle.

Right of Way on the ground

33.—(1) This Rule shall apply to—

- (a) flying machines; and
- (b) vehicles

on any part of a land aerodrome provided for the use of aircraft and under the control of the person in charge of the aerodrome.

(2) Notwithstanding any air traffic control clearance it shall remain the duty of the commander of an aircraft to take all possible measures to ensure that his aircraft does not collide with any other aircraft or with any vehicle.

(3) (a) Flying machines and vehicles shall give way to aircraft which are taking off or landing.

(b) Vehicles, and flying machines which are not taking off or landing, shall give way to vehicles towing aircraft.

(c) Vehicles which are not towing aircraft shall give way to aircraft.

(4) Subject to the provisions of paragraph (3) of this Rule and of Rule 35(3)(b) of these Rules, in case of danger of collision between two flying machines—

(a) when the two flying machines are approaching head-on or approximately so, each shall alter its course to the right;

(b) when the two flying machines are on converging courses, the one which has the other on its right shall give way to the other and shall avoid crossing ahead of the other unless passing well clear of it;

(c) a flying machine which is being overtaken shall have the right-of-way, and the overtaking flying machine shall keep out of the way of the other flying machine by altering its course to the left until that other flying machine has been passed

and is clear, notwithstanding any change in the relative positions of the two flying machines.

(5) Subject to the provisions of paragraph (3)(b) of this Rule a vehicle shall—

- (a) overtake another vehicle so that the other vehicle is on the left of the overtaking vehicle;
- (b) keep to the left when passing another vehicle which is approaching head-on or approximately so.

Dropping of Tow Ropes etc.

34. Tow ropes, banners or similar articles towed by aircraft shall not be dropped from aircraft except at an aerodrome and:

- (a) in accordance with arrangements made with an air traffic control unit at the aerodrome or, if there is no such unit, with the person in charge of the aerodrome; or
- (b) in the area designated by the marking described in Rule 42(7) of these Rules, and the ropes, banners or similar articles shall be dropped when the aircraft is flying in the direction appropriate for landing.

Aerodromes not having Air Traffic Control Units

35.—(1) (a) An aircraft shall not fly within a zone which the commander of the aircraft knows or ought reasonably to know to be the aerodrome traffic zone of an aerodrome where no air traffic control unit is for the time being notified as being on watch, except for the purpose of taking off or landing at that aerodrome or observing the signals in the signals area with a view to landing there, unless he has the permission of the person in charge of the aerodrome.

(b) An aircraft flying within such a zone for the purpose of observing the signals shall remain clear of cloud and at least 500 feet above the level of the aerodrome.

(2) The commander of an aircraft flying in such a zone or moving on such an aerodrome shall:

- (a) conform to the pattern of traffic formed by other aircraft, or keep clear of the airspace in which the pattern is formed;
- (b) make all turns to the left unless ground signals otherwise indicate; and
- (c) take off and land in the direction indicated by the ground signals or, if no such signals are displayed, into the wind, unless good aviation practice demands otherwise.

(3) (a) A flying machine or glider shall not land on a runway at such an aerodrome unless the runway is clear of other aircraft

(b) Where take-offs and landings are not confined to a runway—

- (i) a flying machine or glider when landing shall leave clear on its left any aircraft which has already landed or is already landing or is about to take off; if such a flying machine or glider is obliged to turn, it shall turn to the left after the commander of the aircraft has satisfied himself that such action will not interfere with other traffic movements; and
- (ii) a flying machine about to take off shall take up position and manoeuvre in such a way as to leave clear on its left any aircraft which is already taking off or is about to take off.

(4) A flying machine after landing shall move clear of the landing area in use as soon as it is possible to do so.

Aerodromes having Air Traffic Control Units

36.—(1) An aircraft shall not fly within a zone which the commander of the aircraft knows or ought reasonably to know to be the aerodrome traffic zone of an aerodrome where an air traffic control unit is for the time being notified as being on watch, except for the purpose of observing any signals at that aerodrome with a view to landing there, unless he has the permission of the appropriate air traffic control unit.

(2) The commander of an aircraft flying in the aerodrome traffic zone of an aerodrome where an air traffic control unit is for the time being notified as being on watch, or moving on such an aerodrome shall—

- (a) cause a continuous watch to be maintained on the appropriate radio frequency notified for air traffic control communications at the aerodrome, or, if this is not possible, cause a watch to be kept for such instructions as may be issued by visual means;
- (b) not taxi on the apron or manœuvring area or take off or land anywhere in the zone except with the permission of the air traffic control unit;
- (c) comply with the provisions of Rule 35(1)(b), (2), (3) and (4) of these Rules as if the aerodrome did not have an air traffic control unit, unless he has the permission of the air traffic control unit at the aerodrome, or has been instructed by that unit, to do otherwise.

(3) Without prejudice to the provisions of Rules 21 and 28 of these Rules, the commander of an aircraft shall, immediately upon arrival at, or prior to departure from, an aerodrome within the United Kingdom having an air traffic control unit, ensure that such unit is informed of the flight which he has just made or which he is about to undertake.

Special Rules for certain Aerodromes

37.—(1) The special provisions set out in this Rule shall apply in addition to the other Rules in this Section, in relation to the aerodromes specified in this Rule.

(2) In relation to Glasgow and Prestwick Airports, the following special rules shall apply:

Unless it is otherwise authorised by an air traffic control unit at the aerodrome,

- (a) an aircraft shall not fly at less than 2,000 feet above the notified elevation of the aerodrome within five nautical miles of the notified aerodrome reference point, unless the commander of the aircraft, before so flying, obtains the permission of the air traffic control unit at the aerodrome, and informs the air traffic control unit, on the notified radio frequency appropriate to the circumstances, of the aircraft's position, level and track; and
- (b) while the aircraft is at less than 2,000 feet above the notified elevation of the aerodrome and within five nautical miles of the notified aerodrome reference point, the commander of the aircraft shall cause a continuous watch to be maintained on that frequency and comply with any instructions which the air traffic control unit at the aerodrome may give in the particular case;

Provided that this paragraph shall not apply to flights made outside the notified hours of watch of the air traffic control unit at the aerodrome.

(3) In relation to Blackpool (Squires Gate) Aerodrome the following special rules shall apply:

- (a) an aircraft shall not during the notified hours of watch of the air traffic control unit at the aerodrome fly within the aerodrome traffic zone of Blackpool (Squires Gate) Aerodrome unless the commander of the aircraft, before so flying, obtains the permission of the air traffic control unit at the aerodrome; and
- (b) while the aircraft is flying within the said aerodrome traffic zone at any time during the said hours of watch the commander of the aircraft shall cause a continuous watch to be maintained on the radio frequency required by that air traffic control unit if the aircraft is suitably equipped for that purpose and comply with any instructions which that air traffic control unit may give in the particular case.

(4) In relation to Glamorgan (Rhoose) Airport, the following special rules shall apply:

Unless it is otherwise authorised by the air traffic control unit at the aerodrome,

- (a) an aircraft shall not, during the notified hours of watch of the air traffic control

unit at the aerodrome, fly within the relevant airspace unless the commander of the aircraft, before so flying, obtains the permission of the air traffic control unit at the aerodrome, and informs the air traffic control unit, on the notified radio frequency appropriate to the circumstances, of the aircraft's position, level and track; and

- (b) while the aircraft is within the relevant airspace at any time during the said hours of watch the commander of the aircraft shall cause a continuous watch to be maintained on that frequency and comply with any instructions which the air traffic control unit at the aerodrome may give in the particular case.

For the purposes of this paragraph the "relevant airspace" means the airspace from the surface to flight level 55 within five nautical miles of the notified aerodrome reference point.

- (5) In relation to Liverpool Airport the following special rules shall apply:

Unless it is otherwise authorised by the air traffic control unit at the aerodrome,

- (a) an aircraft shall not fly within the relevant airspace during the notified hours of watch of the air traffic control unit at the aerodrome unless the commander of the aircraft, before so flying, obtains the permission of the air traffic control unit at the aerodrome and informs the air traffic control unit, on the notified radio frequency appropriate to the circumstances, of the aircraft's position, level and track; and
- (b) while the aircraft is within the relevant airspace at any time during the said hours of watch the commander of the aircraft shall cause a continuous watch to be maintained on that frequency and comply with any instructions which the air traffic control unit at the aerodrome may give in the particular case.

For the purposes of this paragraph the "relevant airspace" means the airspace from the surface to 1,250 feet above mean sea level within the area defined by a straight line joining the points 53°19'00"N 02°37'00"W and 53°22'00"N 02°39'00"W and thence by tangents from those points to the circle with radius of six nautical miles centred on 53°20'20"N 02°53'00"W.

- (6) In relation to Southend Airport the following special rules shall apply:

Unless it is otherwise authorised by the air traffic control unit at the aerodrome,

- (a) an aircraft shall not, during the notified hours of watch of the air traffic control unit at the aerodrome, fly within eight nautical miles of the notified aerodrome reference point and at less than 6,500 feet above mean sea level, unless the commander of the aircraft, before so flying, obtains the permission of the air traffic control unit at the aerodrome and informs the air traffic control unit, on the notified radio frequency appropriate to the circumstances, of the aircraft's position, level and track; and
- (b) while the aircraft is within eight nautical miles of the notified aerodrome reference point, and at less than 6,500 feet above mean sea level at any time during the said hours of watch, the commander of the aircraft shall cause a continuous watch to be maintained on that frequency and comply with any instructions which the air traffic control unit at the aerodrome may give in the particular case:

Provided that except at night the special rules (a) and (b) shall not apply in relation to an aircraft which remains at least one nautical mile horizontally and 1,000 feet vertically away from cloud and in a flight visibility of at least five nautical miles.

- (7) In relation to London (Gatwick) Airport, the following special rules shall apply:

Unless it is otherwise authorised by the air traffic control unit at the aerodrome,

- (a) an aircraft shall not fly within the relevant airspace unless the commander of the aircraft, before so flying, obtains the permission of the air traffic control unit at the aerodrome and informs the air traffic control unit, on the notified radio frequency appropriate to the circumstances, of the aircraft's position, level and track; and

- (b) while the aircraft is within the relevant airspace the commander of the aircraft shall cause a continuous watch to be maintained on that frequency and comply with any instructions which the air traffic control unit at the aerodrome may give in the particular case.

For the purposes of this paragraph the "relevant airspace" means the airspace from the surface to 2,000 feet above the notified elevation of the aerodrome within that part of a circle having a radius of eight nautical miles from 51°08'54"N 00°11'25"W, which lies between two straight lines joining respectively the points 51°10'20"N 00°24'00"W to 51°13'15"N 00°00'45"W and 51°02'48"N 00°19'50"W to 51°05'11"N 00°00'05"W.

- (8) In relation to Birmingham Airport, the following special rules shall apply:

Unless it is otherwise authorised by the air traffic control unit at the aerodrome,

- (a) an aircraft shall not, during the notified hours of watch of the air traffic control unit at the aerodrome, fly within the relevant airspace unless the commander of the aircraft, before so flying, obtains the permission of the air traffic control unit at the aerodrome and informs the air traffic control unit, on the notified radio frequency appropriate to the circumstances, of the aircraft's position, level and track; and
- (b) while the aircraft is within the relevant airspace at any time during the said hours of watch the commander of the aircraft shall cause a continuous watch to be maintained on that frequency and comply with any instructions which the air traffic control unit at the aerodrome may give in the particular case.

For the purposes of this paragraph the "relevant airspace" means the airspace within eight nautical miles of the notified aerodrome reference point—

- (i) to the north east of any point on a straight line joining the points 52°35'05"N 01°42'25"W and 52°26'25"N 01°31'55"W from the surface to flight level 35; and
- (ii) in the remainder of that area, from the surface to flight level 110.

(9) (a) In relation to Lyneham Aerodrome, the special rules set forth in subparagraph (b) of this paragraph shall apply to the airspace (in this paragraph called the "relevant airspace")

- (i) from the surface to 3,000 feet above mean sea level within the area defined by straight lines joining successively the following points 51°36'20"N 02°08'38"W to 51°38'12"N 02°03'08"W to 51°37'25"N 01°48'10"W thence by that part of the arc of a circle radius 8 nautical miles centred on 51°31'25"N 01°56'32"W to 51°24'32"N 01°50'05"W thence by a straight line to 51°22'31"N 01°55'40"W and thence by that part of the arc of a circle radius 8 nautical miles centred on 51°29'25"N 02°02'08"W to 51°36'20"N 02°08'38"W; and
- (ii) from 3,000 feet above mean sea level to flight level 65 vertically above the area specified in (i) above; and
- (iii) from flight level 40 to flight level 65 within the area defined by straight lines joining successively the following points 51°37'25"N 01°48'10"W to 51°36'57"N 01°39'19"W to 51°26'57"N 01°40'43"W to 51°27'13"N 01°45'39"W; thence by that part of the arc of a circle radius 8 nautical miles centred on 51°31'25"N 01°56'32"W to 51°37'25"N 01°48'10"W.
- (b) Unless it is otherwise authorised by the air traffic control unit at the aerodrome,
- (i) an aircraft shall not fly within the relevant airspace unless the commander of the aircraft, before so flying, obtains the permission of the air traffic control unit at the aerodrome and informs the air traffic control unit, on the notified radio frequency appropriate to the circumstances, of the aircraft's position, level and track; and
- (ii) while the aircraft is within the relevant airspace the commander of the aircraft shall cause a continuous watch to be maintained on the notified radio frequency appropriate to the circumstances and comply with any instructions which the air traffic control unit at the aerodrome may give in the particular case:

Provided that this subparagraph shall not apply in relation to an aircraft which:

- (a) flies in Visual Meteorological Conditions within that part of the relevant airspace specified in sub-paragraph (a) (ii) and (iii) of this paragraph; or
- (b) remains in sight of the surface clear of cloud and in a flight visibility of at least one nautical mile and which is not equipped with radio capable of operating on the said radio frequency whilst flying within that part of the relevant airspace—

from the surface to 1,900 feet above mean sea level east of a straight line joining 51°37'37"N 01°51'08"W and 51°29'38"N 01°44'00"W; or from the surface to 1,500 feet above mean sea level south of a straight line joining 51°22'57"N 02°09'40"W and 51°21'57"N 01°57'45"W; or

- (c) flies within the airspace from the surface to 1,900 feet above mean sea level within an area comprising a circle of radius 2½ nautical miles centred on 51°30'20"N 01°48'00"W (Wroughton Aerodrome) excluding that part of the circle east of a straight line joining 51°32'42"N 01°46'44"W and 51°29'45"N 01°44'08"W.

(10) In relation to Leeds and Bradford Airport the following special rules shall apply:

Unless it is otherwise authorised by the air traffic control unit at the aerodrome,

- (a) an aircraft shall not, during the notified hours of watch of the air traffic control unit at the aerodrome, fly within the relevant airspace unless the commander of the aircraft, before so flying, obtains the permission of the air traffic control unit at the aerodrome and informs the air traffic control unit, on the notified radio frequency appropriate to the circumstances, of the aircraft's position, level and track; and
- (b) while the aircraft is within the relevant airspace at any time during the said hours of watch, the commander of the aircraft shall cause a continuous watch to be maintained on that frequency and comply with any instructions which the air traffic control unit at that aerodrome may give in the particular case:

Provided that except at night the special rules (a) and (b) shall not apply to an aircraft flying within the relevant airspace which remains at least one nautical mile horizontally and 1,000 feet vertically away from cloud and in a flight visibility of at least five nautical miles.

For the purposes of this paragraph the "relevant airspace" means the airspace from the surface to flight level 85 above the aerodrome within that part of a circle having a radius of eight nautical miles centred on 53°52'00"N 01°39'10"W (Leeds and Bradford Airport) except that part of the circle on the east side of straight lines joining the points 54°00'00"N 01°38'45"W, 53°56'20"N 01°33'20"W, and 53°53'45"N 01°31'00"W, 53°46'45"N 01°29'00"W.

SECTION VIII

SPECIAL RULES FOR LOW-LEVEL CROSS-CHANNEL AIR TRAFFIC

38.—(1) Notwithstanding the provisions of Rule 23, during the notified hours of watch of the Air Traffic Control Unit at Lydd Airport, the following special rules shall apply to the airspace (in this Rule called "the relevant airspace")

over the sea, between 500 feet and 4,500 feet,
elsewhere, between 1,000 feet and 4,500 feet

above mean sea level within the area defined by straight lines joining successively the following points:

51°30'00"N 00°53'10"E; 51°30'00"N 02°00'00"E; 51°07'00"N 02°00'00"E;
51°00'00"N 01°28'00"E; 50°40'00"N 01°28'00"E; 50°36'20"N 01°18'30"E;
50°57'42"N 00°43'34"E; 51°08'30"N 00°52'00"E; 51°18'50"N 00°53'10"E;
51°26'20"N 00°45'50"E; and thence by that part of the arc of a circle radius eight nautical miles centred on Southend Airport (51°34'15"N 00°42'00"E) to 51°30'00"N 00°53'10"E;

from 4,500 feet to 6,000 feet above mean sea level within that part of the aforesaid area which lies north of a line from 51°26'20"N 00°45'50"E to 51°22'28"N 01°26'51"E and thence to 51°16'00"N 02°00'00"E;

and from the surface—

over the sea, to 500 feet above mean sea level,
elsewhere, to 1,000 feet above mean sea level

within—

- (i) an area comprising two circles each with a radius of five nautical miles whose centres are at 50°57'16"N 00°56'22"E (Lydd Airport) and 51°04'50"N 01°01'10"E (Lympne Airport) respectively and the area enclosed between those circles and two parallel lines each forming a tangent to both circles; and
- (ii) an area comprising two circles each with a radius of 5 nautical miles whose centres are at 51°20'30"N 01°20'50"E and 51°19'35"N 01°28'45"E respectively and the area enclosed between those circles and two parallel lines each forming a tangent to both circles and an adjoining area defined by straight lines joining successively the following points:
51°19'35"N 01°13'00"E; 51°20'40"N 01°04'30"E;
51°24'40"N 01°05'45"E; 51°23'30"N 01°14'15"E

but excluding—

- (a) such parts of that airspace as may from time to time be notified as controlled airspace, including that notified for the purpose of Rule 22 of these Rules; and
- (b) the airspace between ground level and 1,000 feet above mean sea level defined by straight lines joining successively the following points—

51°21'18"N 01°28'15"E; 51°25'24"N 01°27'11"E;

51°23'35"N 01°21'59"E; 51°20'44"N 01°24'38"E;

51°20'52"N 01°26'30"E; 51°21'18"N 01°28'15"E.

(2) The commander of an aircraft who intends to fly within the relevant airspace shall before so flying cause to be communicated to the appropriate air traffic control unit a flight plan containing particulars of the time at which and the level and track on which the aircraft is intended to pass through the relevant airspace, and such particulars of the intended flight as may be necessary for search and rescue purposes.

(3) The commander of an aircraft shall, before the aircraft enters the relevant airspace, inform the air traffic control unit serving that part of the relevant airspace which the aircraft is about to enter, on the notified radio frequency appropriate to the circumstances, of the time, position and level at which the aircraft will enter that airspace, and when the aircraft leaves the relevant airspace, shall inform the air traffic control unit serving the area which the aircraft is leaving, on the said frequency, of the time, position and level at which the aircraft is leaving the relevant airspace.

(4) While flying within the relevant airspace, the commander of an aircraft shall—

- (a) cause a continuous watch to be maintained on the notified radio frequency appropriate to the circumstances;
- (b) measure the level of flight by means of an altimeter set according to the system notified for the relevant airspace; and
- (c) comply with any instructions which the appropriate air traffic control unit may give in the particular case.

(5) Paragraphs (3) and (4)(a) of this Rule shall not apply to aircraft which are not equipped with radio capable of operating on the radio frequency therein referred to. Such aircraft shall not fly within the relevant airspace except in accordance with procedures and on a route notified for that purpose or in conformity with an air traffic control clearance issued for the flight by the appropriate air traffic control unit and when flying within the relevant airspace shall remain in sight of the surface, clear of cloud and in a flight visibility of at least three nautical miles.

(6) These special rules shall not apply in relation to any glider which remains at least one nautical mile horizontally and 1,000 feet vertically away from cloud, in a flight visibility of at least five nautical miles and outside those parts of the relevant airspace between the surface and 4,500 feet above mean sea level which fall within the areas specified in paragraph (1)(i) and (ii) of this Rule.

SECTION IX

AERODROME SIGNALS AND MARKINGS: VISUAL AND AURAL SIGNALS

General

39.—(1) Whenever any signal specified in this Section of these Rules is given or displayed, or whenever any marking so specified is displayed, by any person in an aircraft, or at an aerodrome, or at any other place which is being used by aircraft for landing or take-off, it shall, when given or displayed in the United Kingdom, have the meaning assigned to it in this Section.

(2) All dimensions specified in this Section of these Rules shall be subject to a tolerance of 10 per cent, plus or minus.

Signals in the Signals Area

40.—(1) When any signal specified in the following paragraphs of this Rule is displayed it shall be placed in a signals area, which shall be a square visible in all directions bordered by a white strip one foot wide the internal sides measuring 40 feet.

(2) A white landing T, as illustrated in this paragraph,

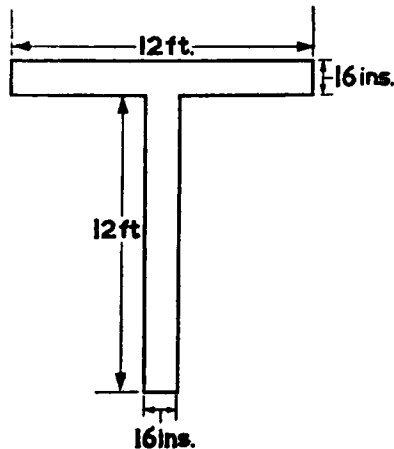

Fig. 1.

signifies that aeroplanes and gliders taking off or landing shall do so in a direction parallel with the shaft of the T and towards the cross arm, unless otherwise authorised by the appropriate air traffic control unit.

(3) A white disc two feet in diameter displayed alongside the cross arm of the T and in line with the shaft of the T, as illustrated in this paragraph,

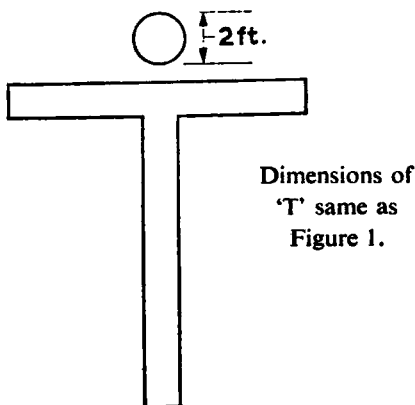

Fig. 2.

signifies that the direction of landing and take-off do not necessarily coincide.

(4) A white dumb-bell, as illustrated in this paragraph,

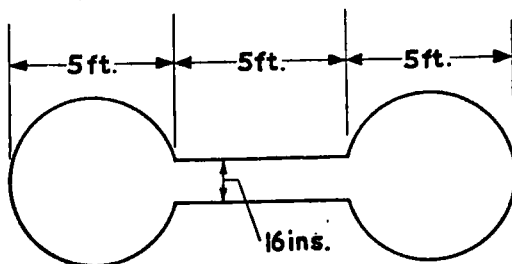

Fig. 3.

signifies that movements of aeroplanes and gliders on the ground shall be confined to paved, metallised or similar hard surfaces.

(5) A white dumb-bell as described in (4) above but with a black strip two feet wide across each disc at right angles to the shaft of the dumb-bell, as illustrated in this paragraph,

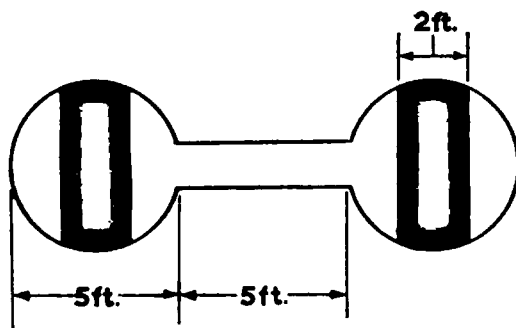

Fig. 4.

signifies that aeroplanes and gliders taking off or landing shall do so on a runway but that movement on the ground is not confined to paved, metallised or similar hard surfaces.

(6) A red and yellow striped arrow, as illustrated in this paragraph,

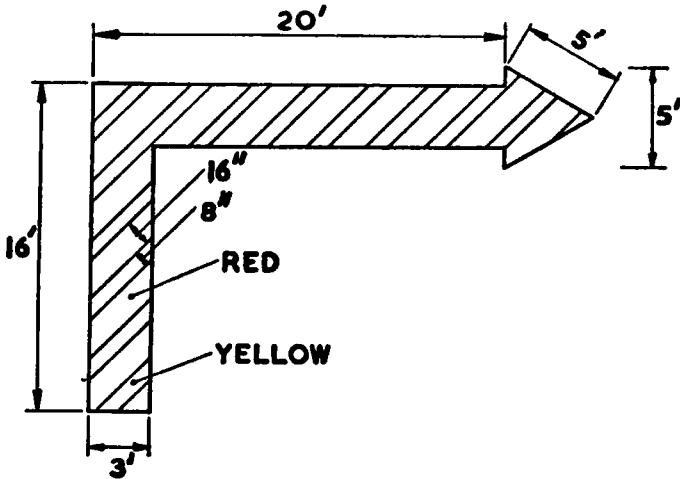

Fig. 5.

the shaft of which is at least three feet wide placed along the whole or not less than a total of 36 feet of two adjacent sides of the signals area and pointing in a clockwise direction signifies that a right-hand circuit is in force.

(7) A red panel 10 feet square with a yellow strip along one diagonal at least 20 inches wide, as illustrated in this paragraph,

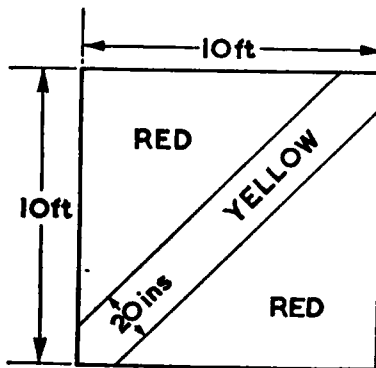
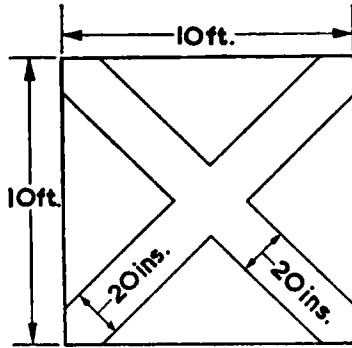

Fig. 6.

signifies that the state of the manœuvring area is poor and that pilots must exercise special care when landing.

(8) A red panel 10 feet square with a yellow strip, at least 20 inches wide, along each diagonal, as illustrated in this paragraph,



Yellow stripes on red background.

Fig. 7.

signifies that the aerodrome is unsafe for the movement of aircraft and that landing on the aerodrome is prohibited.

(9) A white letter H, as illustrated in this paragraph,

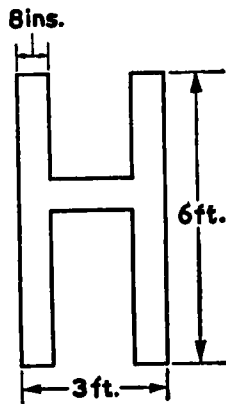

Fig. 8.

signifies that helicopters shall take-off and land only within the area designated by the marking specified in Rule 42(5) of these Rules.

(10) A red letter L displayed on the dumb-bell specified in paragraphs (4) and (5) of this Rule, as illustrated in this paragraph,

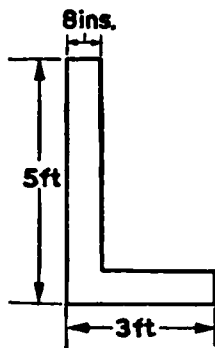

Fig. 9.

signifies that light aircraft are permitted to take off and land either on a runway or on the area designated by the marking specified in Rule 42(6) of these Rules.

(11) A white double cross, as illustrated in this paragraph,

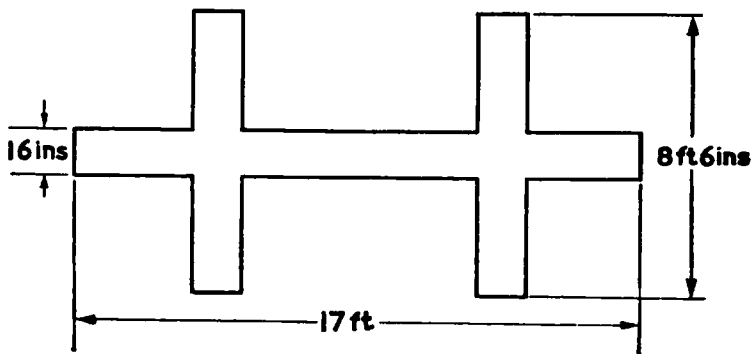

Fig. 10.

signifies that glider flying is in progress.

Markings for Paved Runways and Taxiways

41.—(1) Two or more white crosses, as illustrated in this paragraph,

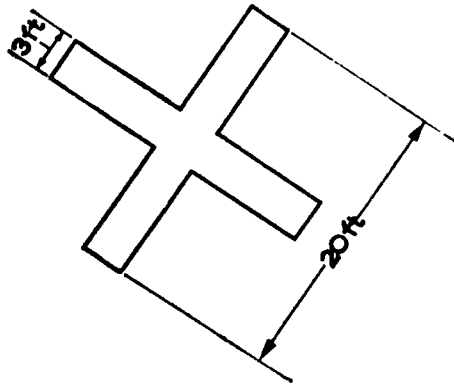

Fig. 11.

displayed on a runway or taxiway, with the arms of the crosses at an angle of 45° to the centre line of the runway, at intervals of not more than 1,000 feet signify that the section of the runway or taxiway marked by them is unfit for the movement of aircraft.

(2) A broken white line and a continuous line, as illustrated in this paragraph,

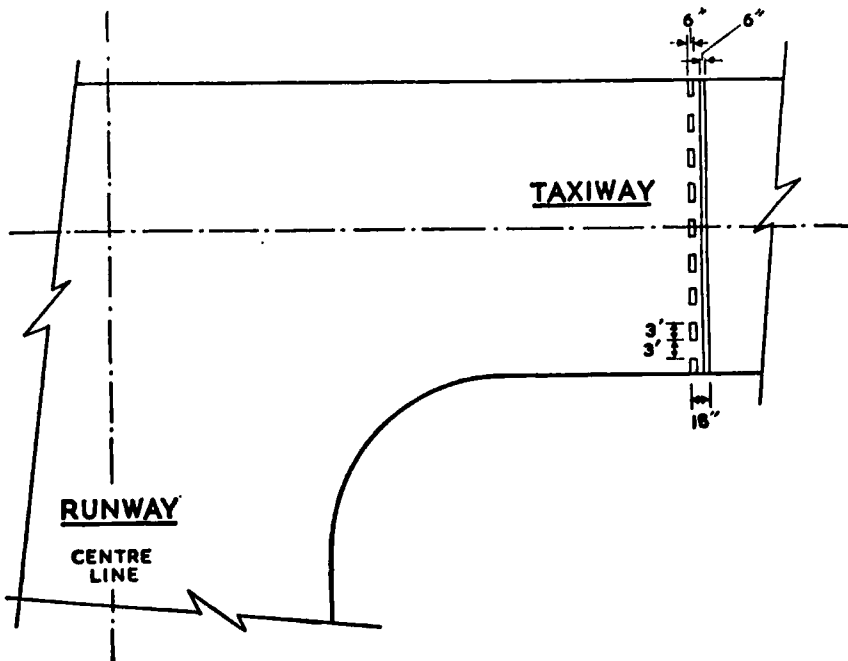

Fig. 12.

signify a holding position beyond which no part of an aircraft or vehicle shall project in the direction of the runway without permission from an air traffic control unit.

(3) Orange and white markers, as illustrated in this paragraph,

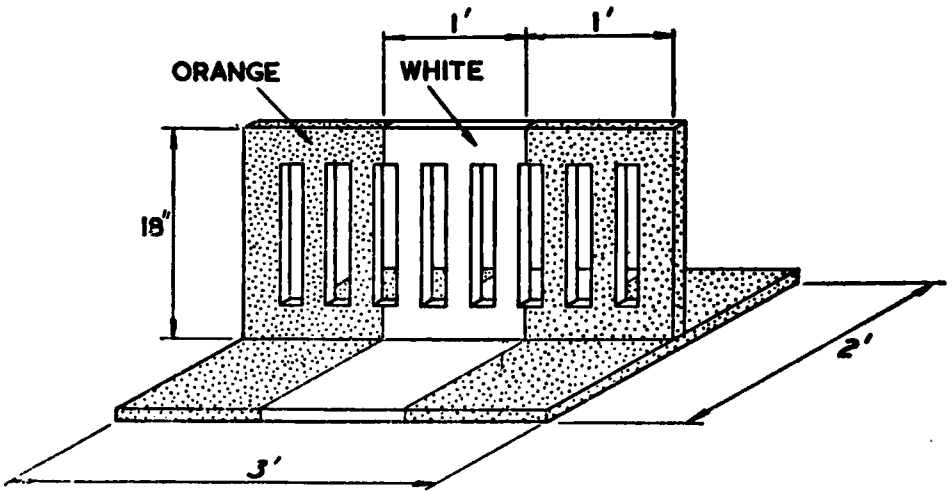

Fig. 13.

spaced not more than 150 feet apart, signify the boundary of that part of a paved runway, taxiway or apron which is unfit for the movement of aircraft.

Markings on Unpaved Manœuvring Areas

42.—(1) Markers with orange and white stripes of an equal width of not less than 1½ feet, with an orange stripe at each end, as illustrated in this paragraph,

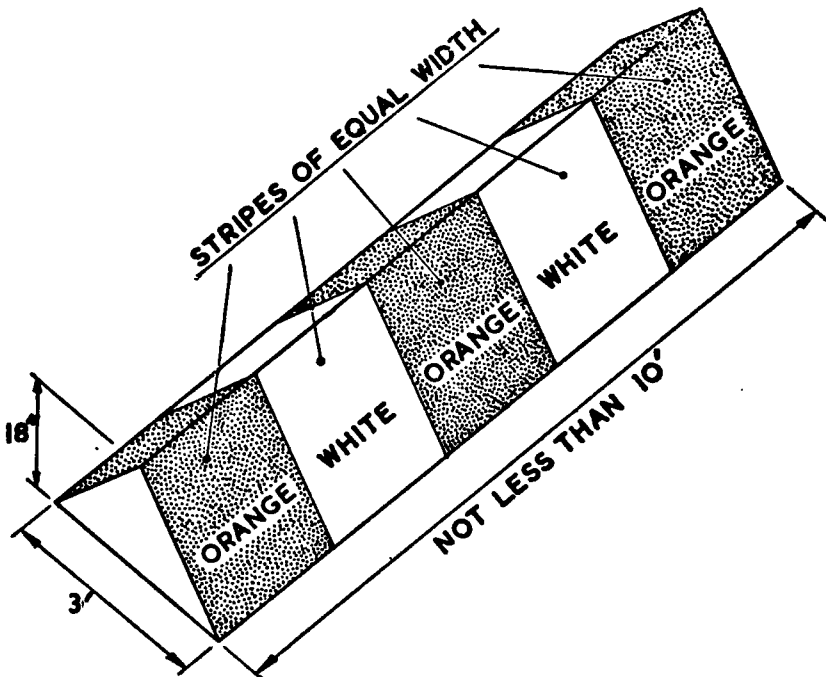

Fig. 14.

alternating with flags not less than 2 feet square showing equal orange and white triangular areas, indicate the boundary of an area unfit for the movement of aircraft and one or more white crosses as specified in Rule 41(1) of these Rules indicate the said area. The distance between any two successive orange and white flags shall not exceed 300 feet.

(2) Striped markers, as specified in paragraph (1) of this Rule, spaced not more than 150 feet apart, indicate the boundary of an aerodrome.

(3) On structures, markers with orange and white vertical stripes, of an equal width of not less than $1\frac{1}{2}$ feet, with an orange stripe at each end, as illustrated in this paragraph,

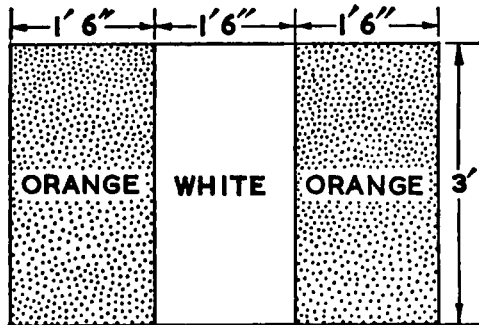

Fig. 15.

spaced not more than 150 feet apart, indicate the boundary of an aerodrome. The pattern of the marker shall be visible from inside and outside the aerodrome and the marker shall be affixed not more than 6 inches from the top of the structure.

(4) White flat rectangular markers 10 feet long and 3 feet wide at intervals not exceeding 300 feet, flush with the surface of the unpaved runway or stopway, as the case may be, indicate the boundary of an unpaved runway or of a stopway.

(5) A white letter H, as illustrated in this paragraph,

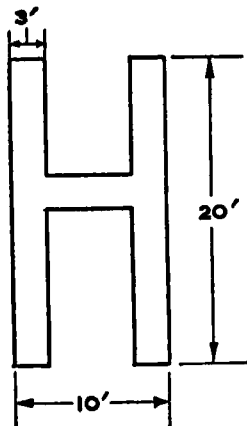

Fig. 16.

indicates an area which shall be used only for the taking off and landing of helicopters.

(6) A white letter L as illustrated in this paragraph,

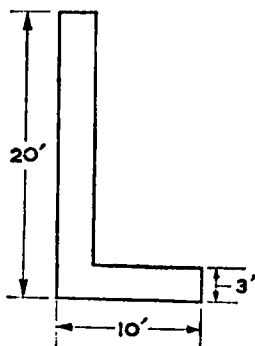

Fig. 17.

indicates a part of the manœuvring area which shall be used only for the taking off and landing of light aircraft.

(7) A yellow cross, with two arms 20 feet long by 3 feet wide at right angles, indicates that tow ropes and similar articles towed by aircraft shall only be dropped in the area in which the cross is placed.

(8) A white double cross as illustrated in this paragraph,

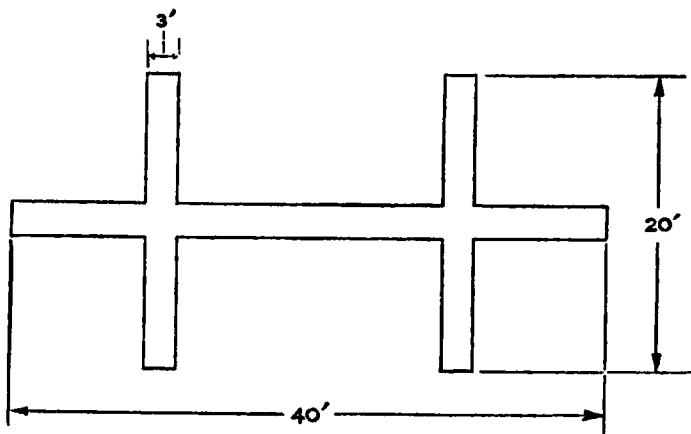

Fig. 18.

indicates an area which shall be used only for the taking off and landing of gliders.

(9) A white landing T as specified in Rule 40(2) of these Rules placed at the left hand side of the runway when viewed from the direction of landing indicates the runway to be used, and at an aerodrome with no runway it indicates the direction for take-off and landing.

Signals Visible from the Ground

43.—(1) A black ball 2 feet in diameter suspended from a mast signifies that the directions of take-off and landing are not necessarily the same.

(2) A checkered flag or board, 4 feet by 3 feet containing twelve equal squares, 4 horizontally and 3 vertically, coloured red and yellow alternately, signifies that aircraft may move on the manoeuvring area and apron only in accordance with the permission of the air traffic control unit at the aerodrome.

(3) Two red balls 2 feet in diameter, disposed vertically one above the other, 2 feet apart and suspended from a mast, signify that glider flying is in progress at the aerodrome.

(4) Black arabic numerals in two-figure groups and, where parallel runways are provided the letter or letters L (left), LC (left centre), C (centre), RC (right centre) and R (right), placed against a yellow background, indicate the direction for take-off or the runway in use.

(5) A black letter C against a yellow background, as illustrated in this paragraph,

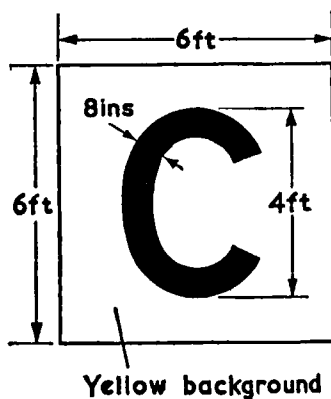

Fig. 19.

indicates the position at which a pilot can report to the air traffic control unit or to the person in charge of the aerodrome.

(6) A rectangular green flag of not less than 2 feet square flown from a mast indicates that a right hand circuit is in force.

Lights and Pyrotechnic Signals for Control of Aerodrome Traffic

44. Each signal described in the first column of Table A, when directed from an aerodrome to an aircraft or to a vehicle, or from an aircraft, shall have the meanings respectively appearing in the second, third and fourth columns of that Table opposite the description of the signal.

TABLE A—MEANING OF LIGHTS AND PYROTECHNIC SIGNALS (RULE 44)

Characteristic and colour of light beam or pyrotechnic	From an aerodrome		From an aircraft in flight to an aerodrome
	to an aircraft in flight	to an aircraft or vehicle on the aerodrome	
(a) Continuous red light	Give way to other aircraft and continue circling.	Stop.	—
(b) Red pyrotechnic light, or	Do not land; wait for permission.	—	Immediate assistance is requested.
(c) Red flare		Do not land; aerodrome not available for landing.	
(d) Green flashes	Return to aerodrome; wait for permission to land.	To an aircraft: You may move on the manoeuvring area and apron; To a vehicle: You may move on the manoeuvring area.	—
(e) Continuous green light	You may land.	You may take off (not applicable to a vehicle).	—
(f) Continuous green light, or	—	—	By night: May I land? By day: May I land in direction different from that indicated by landing T?
(g) White flashes			
(h) White pyrotechnic lights, or	—	—	I am compelled to land.
Switching on and off the navigation lights, or			
Switching on and off the landing lights			

Marshalling Signals

45. Each of the signals for the guidance of aircraft manoeuvring on the ground, described in the first column of Table B, paragraphs (a) to (n), and in relation to helicopters manoeuvring on or off the ground, paragraphs (o) to (s) shall, in the United Kingdom, have the meaning set forth in the second column of that Table opposite the description of the signal. By day any such signals shall be given by hand or by circular bats and by night by torches or illuminated wands.

TABLE B—MEANING OF MARSHALLING SIGNALS (RULE 45)

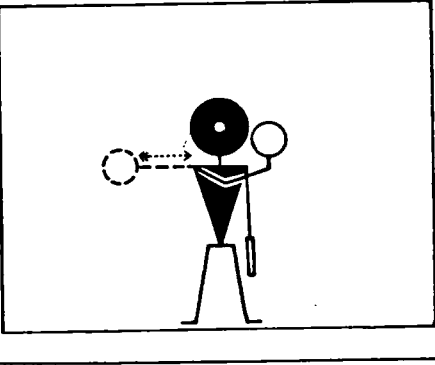
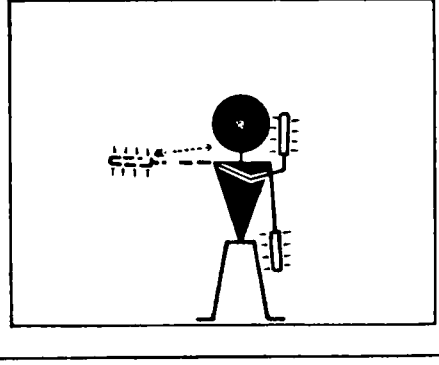
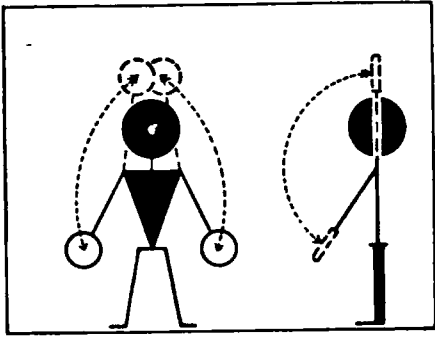
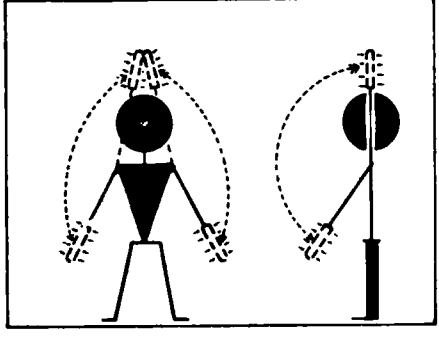
Description of Signal	Meaning of Signal	In Daylight	By Night
(a) Right or left arm down, the other arm moved across body and extended to indicate position of the other marshaller.	Proceed under guidance of another marshaller.		
(b) Arms repeatedly moved upward and backward, beckoning onward.	Move ahead.		

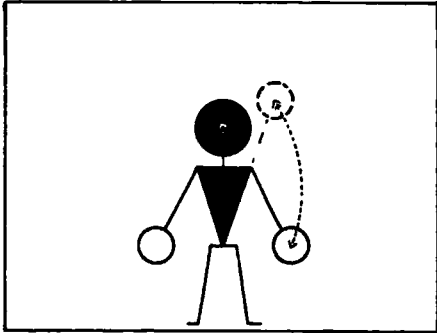
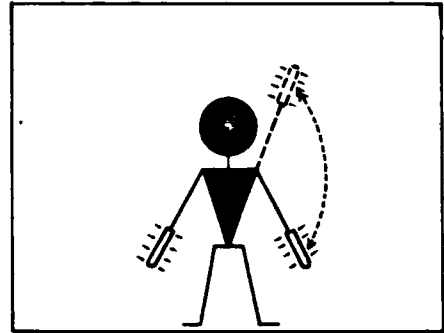
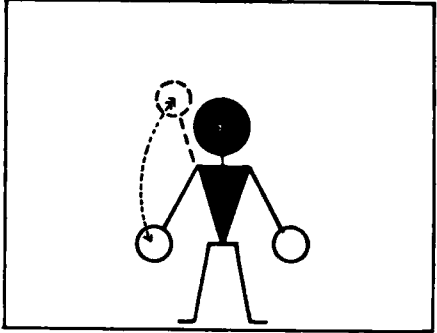
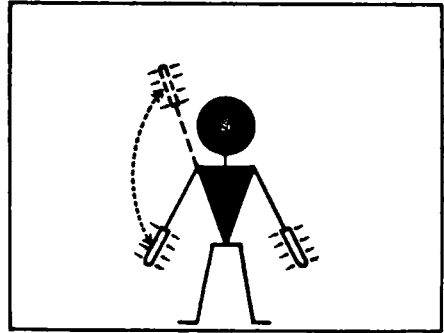
Description of Signal	Meaning of Signal	In Daylight	By Night
<p>(c) Right arm down, left arm repeatedly moved upward and backward. The speed of arm movement indicates the rate of turn.</p>	<p>Open up starboard engine or turn to port.</p>		
<p>(d) Left arm down, the right arm repeatedly moved upward and backward. The speed of arm movement indicates the rate of turn.</p>	<p>Open up port engine or turn to starboard.</p>		

(e) Arms repeatedly crossed above the head. The speed of arm movement indicates the urgency of the stop.

Stop.

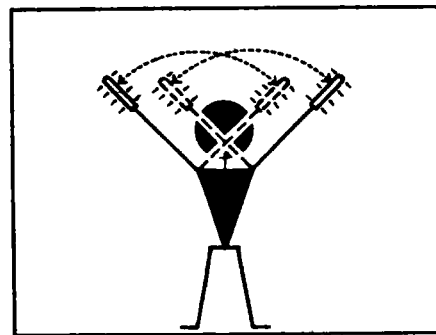
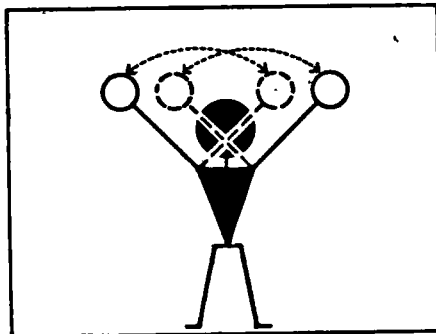

(f) A circular motion of the right hand at head level, with the left arm pointing to the appropriate engine.

Start engines.

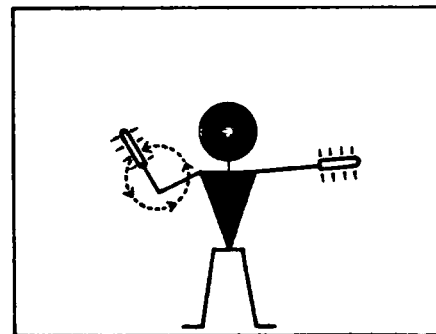
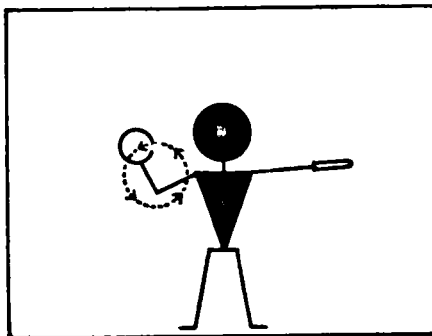

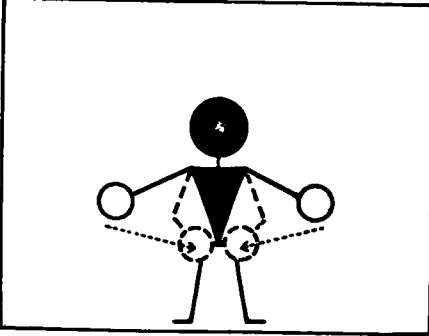
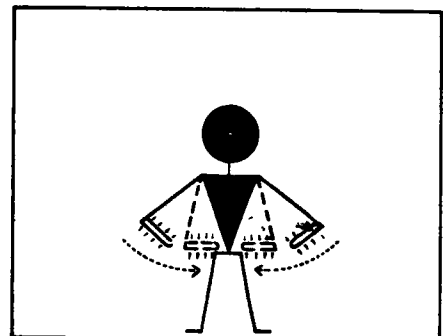
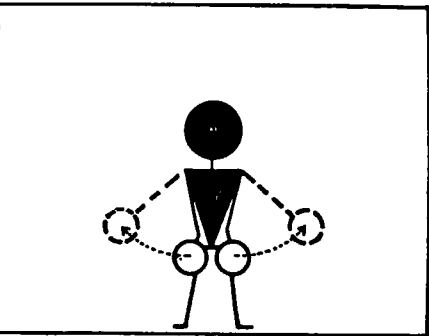
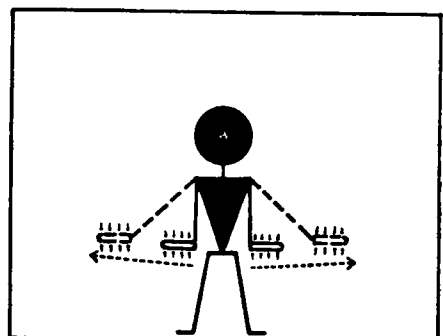
Description of Signal	Meaning of Signal	In Daylight	By Night
(g) Arms extended, the palms facing inwards, then swung from the extended position inwards.	Insert chocks.		
(h) Arms down, the palms facing outwards, then swung outwards.	Chocks away.		

(j) Either arm and hand placed level with the chest, then moved laterally with the palm downwards.

Cut engines.

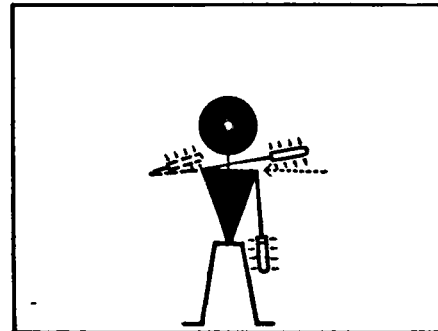
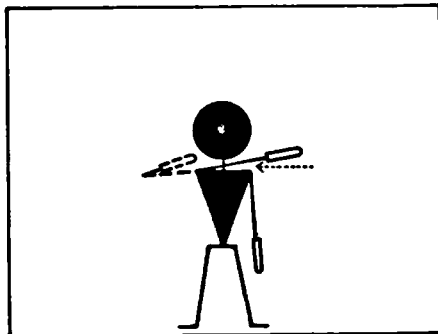

(k) Arms placed down, with the palms towards the ground, then moved up and down several times.

Slow down.

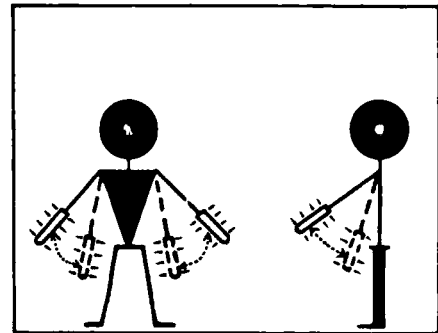
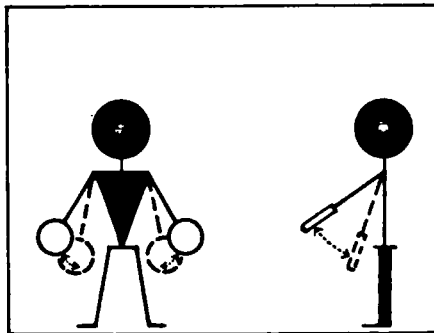

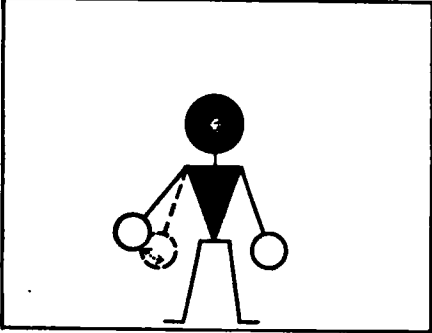
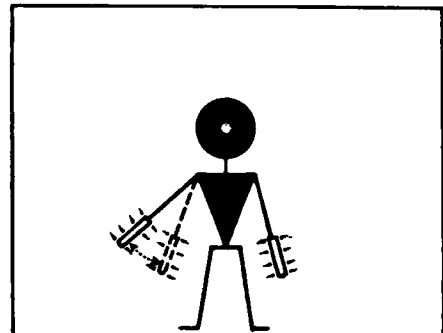
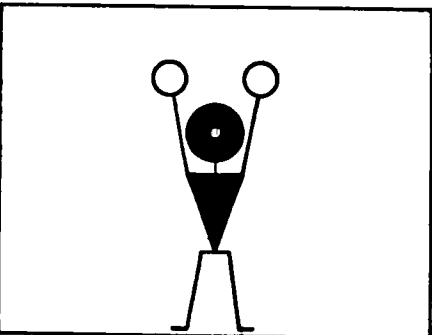
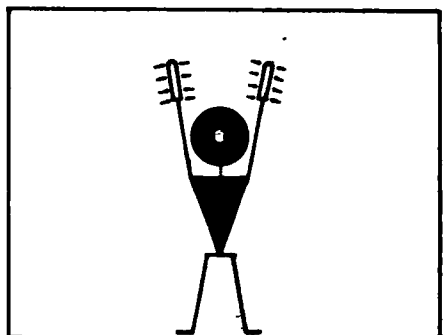
Description of Signal	Meaning of Signal	In Daylight	By Night
<p>(l) Arms placed down, with the palms towards the ground, then either the right or left arm moved up and down indicating that the motors on the left or right side, as the case may be, should be slowed down.</p>	<p>Slow down engines on indicated side.</p>	 <p>A stick figure with a black circular head and a black triangular torso. Its arms are extended downwards, palms facing the ground. The left arm is slightly bent, and a dashed line indicates its movement path. A small circle is attached to the end of the left arm, representing a light.</p>	 <p>A stick figure with a black circular head and a black triangular torso. Its arms are extended downwards, palms facing the ground. The left arm is bent, and a dashed line indicates its movement path. A light with radiating lines is attached to the end of the left arm, representing a flashing light.</p>
<p>(m) Arms placed above the head in a vertical position.</p>	<p>This bay.</p>	 <p>A stick figure with a black circular head and a black triangular torso. Its arms are raised vertically above its head, palms facing forward. Each hand holds a small white circle, representing a light.</p>	 <p>A stick figure with a black circular head and a black triangular torso. Its arms are raised vertically above its head, palms facing forward. Each hand holds a light with radiating lines, representing a flashing light.</p>

(n) The right arm raised at the elbow, with the arm facing forward.

All clear: Marshalling finished.

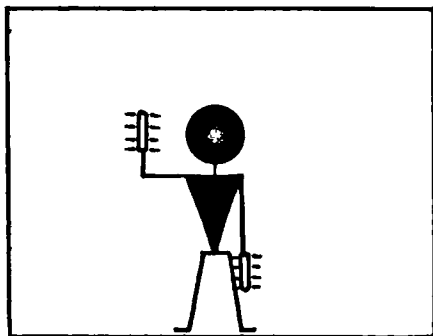
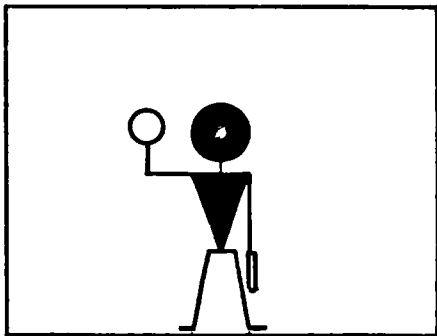

(o) Arms placed horizontally sideways.

Hover.

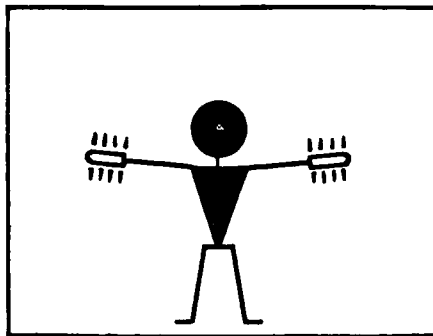
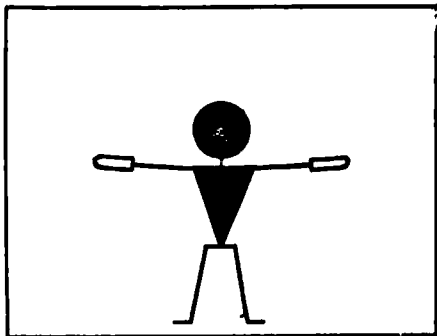

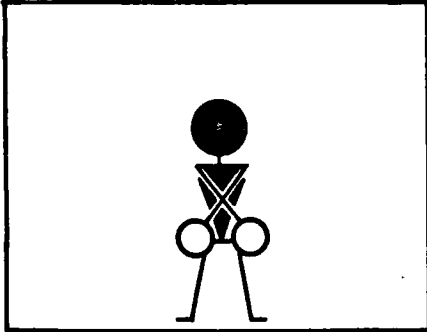
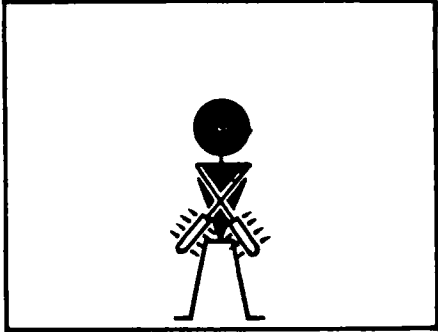
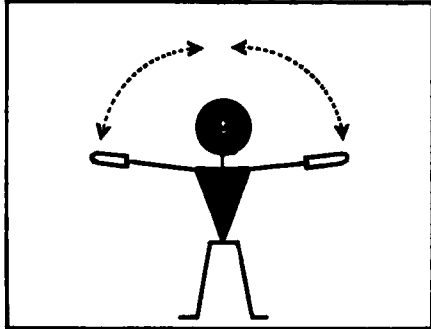
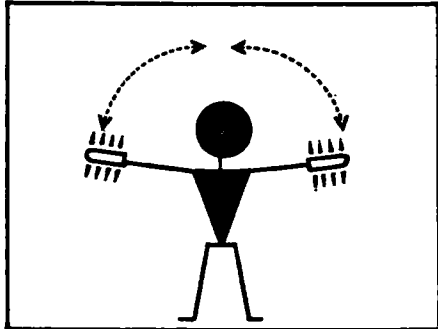
Description of Signal	Meaning of Signal	In Daylight	By Night
<p>(p) Arms placed down and crossed in front of the body.</p>	Land.		
<p>(q) Arms placed horizontally sideways with the palms up beckoning upwards. The speed of arm movement indicates the rate of ascent.</p>	Move upwards.		

(r) Arms placed horizontally sideways with the palms towards the ground beckoning downwards. The speed of arm movement indicates the rate of descent.

Move downwards.

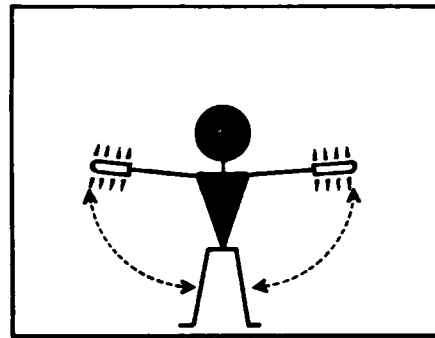
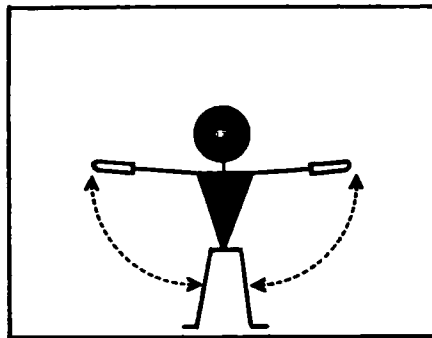

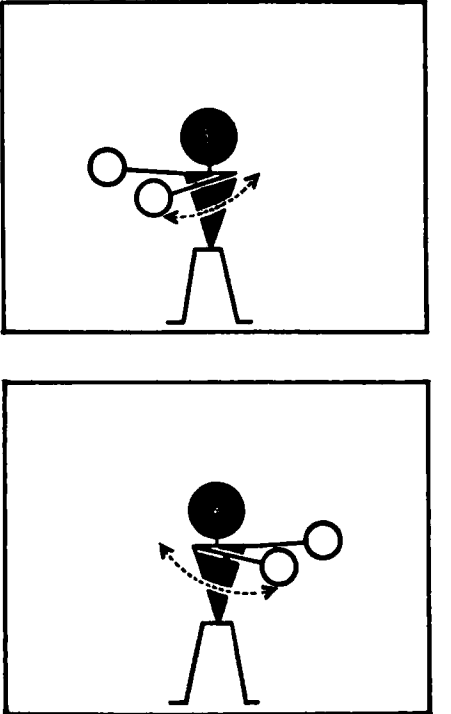
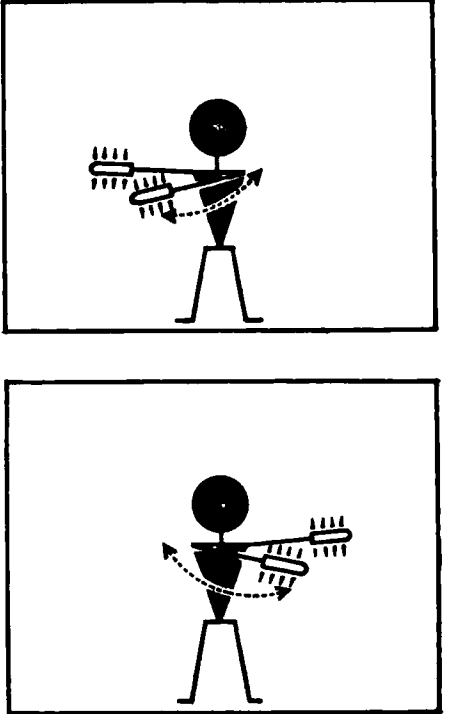
Description of Signal	Meaning of Signal	In Daylight	By Night
<p>(s) Either arm placed horizontally sideways, then the other arm moved in front of the body to that side, in the direction of the movement, indicating that the helicopter should move horizontally to the left or right side, as the case may be; repeated several times.</p>	<p>Move horizontally.</p>		

Distress, Urgency and Safety Signals

46.—(1) The following signals, given either together or separately before the sending of a message, signify that an aircraft is threatened by grave and imminent danger and requests immediate assistance:

- (a) by radiotelephony:
the spoken word "MAYDAY";
- (b) by visual signalling:
 - (i) the signal SOS (··· — — — ···);
 - (ii) a succession of pyrotechnic lights fired at short intervals each showing a single red light;
 - (iii) a parachute flare showing a red light;
- (c) by sound signalling other than radiotelephony:
 - (i) the signal SOS (··· — — — ···);
 - (ii) a continuous sounding with any sound apparatus.

(2) The following signals, given either together or separately, before the sending of a message, signify that the commander of the aircraft wishes to give notice of difficulties which compel it to land but that he does not require immediate assistance:

- (a) a succession of white pyrotechnic lights;
- (b) the repeated switching on and off of the aircraft landing lights;
- (c) the repeated switching on and off of its navigation lights, in such a manner as to be clearly distinguishable from the flashing navigation lights described in Rule 11 of these Rules.

(3) The following signals, given either together or separately, indicate that the commander of the aircraft has an urgent message to transmit concerning the safety of a ship, aircraft, vehicle or other property or of a person on board or within sight of the aircraft from which the signal is given:

- (a) by radiotelephony:
the spoken word "PAN";
- (b) by visual signalling:
the signal XXX (—·— —·— —·—);
- (c) by sound signalling other than radiotelephony:
the signal XXX (—·— —·— —·—).

Warning Signals to Aircraft in Flight

47. In the United Kingdom, the following signals shall respectively have the following meanings:

- (a) (i) by day—a series of projectiles discharged at intervals of ten seconds, each showing on bursting black or white smoke, or
- (ii) by night—a series of projectiles discharged at intervals of ten seconds, each showing on bursting white lights or stars, or an intermittent white luminous beam directed at the aircraft,
indicates that the aircraft to which the signal is directed is in the vicinity of such an area as is referred to in Article 60(1)(c) of the Order and is required to change its course;
- (b) by day or by night, a series of projectiles discharged at intervals of ten seconds, each showing on bursting green lights or stars, indicates that the aircraft is required to land at the nearest aerodrome in accordance with the provisions of Article 60 of the Order.

SECTION X

GROUND LIGHTING

Minimum Ground Lighting

48.—(1) The person in charge of any area to which this Rule applies shall cause the lighting specified in Rules 49 to 54, inclusive, of these Rules to be in operation

whenever a flying machine or glider, flying for the purpose of the public transport of passengers, is taking off or landing at that area by night and during such period before or after the take-off or landing as may be necessary to ensure the safety of the aircraft:

Provided that, if the area is intended for use only by helicopters, there may be in operation in lieu of the lighting specified in Rules 49, 50, 53 and 54 of these Rules, such other lighting as will enable the pilot of a helicopter in flight—

- (i) to identify the area ;
- (ii) to determine the landing direction ; and
- (iii) to make a safe approach and landing.

(2) The requirements of paragraph (1) of this Rule shall be deemed not to have been contravened if neither the person in charge of the area nor any person acting under his instructions knew or ought reasonably to have known that the aircraft was about to take off or land.

(3) This Rule shall apply to any place, whether or not an aerodrome, intended to be used for the taking off, landing of aircraft or the manoeuvring of aircraft on the ground, but shall not apply to any Government aerodrome or to any aerodrome licensed for use by night.

Approach Lighting

49. The lighting required by Rule 48 of these Rules shall include lighting to give approach guidance to the runway or landing area intended to be used, which lighting shall consist of either:

- (a) a line of identical lights each having an intensity of not less than 100 candles of red or white light in the direction of approach, equally spaced at intervals not exceeding 200 feet along the extended centre line of the runway for a distance of not less than 600 feet from the threshold in the direction of approach ; or
- (b) angle of approach lights so arranged as to indicate a sloping path between $2\frac{1}{2}^{\circ}$ and $4\frac{1}{2}^{\circ}$ above the horizontal which will provide, for any aircraft approaching to land, safe clearance above all obstacles within three nautical miles of the threshold of the runway and will give a warning by means of red beams of light if the aircraft is below the path. The lights shall indicate the path throughout an angle in azimuth of not less than 12° symmetrically about a line parallel to the direction of landing :

Provided that if the lights specified in Rule 50(1)(b) are in operation, the lights specified in sub-paragraph (b) of this paragraph shall also be in operation, and not the lights specified in sub-paragraph (a) of this paragraph.

Landing Area Lights

50.—(1) Where a runway is not provided, the lighting required by Rule 48 of these Rules shall include either:

- (a) two lines of white lights parallel to the direction of take-off or landing visible from all directions above the horizontal delineating the landing area intended for use by night, the lights in each line being equally spaced at intervals not exceeding 300 feet. The lines of lights shall not be less than 100 feet nor more than 200 feet apart, and shall be so placed that a line drawn between a light and the opposite light in the parallel line of lights would be at right angles to the direction of use of the landing area ; or
- (b) white lights visible as aforesaid and arranged in the form of a T with the shaft of the T parallel to the direction of use and on the left edge of the area intended for landing when seen from the direction of approach and extending for the whole length of that edge, the lights in the shaft being equally spaced at intervals not exceeding 300 feet, and the cross arm of the T consisting of single lights placed 300 feet on either side of the light in the shaft of the T furthest from the approach end.

(2) Where a runway is provided the lighting required by Rule 48 of these Rules shall include two lines of white lights visible from the direction of approach, placed on the edge of the runway and each extending the whole of the length intended for use, the distance between successive lights in each line being not more than 300 feet, so that, so far as is practicable, a line drawn between a light and the opposite light in the parallel line of lights would be at right angles to the axis of the runway.

(3) The lights required by this Rule shall have an intensity of not less than 50 candles.

Guidance Lights on the Manœuvring Area and other parts of the aerodrome used by aircraft

51. The lighting required by Rule 48 of these Rules shall include either:

(a) the delineation of every taxiway intended for use by night by means of lights along its edges, either blue lights on one side and yellow lights on the other or blue lights on both sides. The lights on each side shall have a brightness sufficient to give adequate guidance to a taxiing aircraft when the lights are spaced not more than 160 feet apart on straight stretches. On curves the lights shall be at reduced spacing to mark the taxiway edge clearly. If the taxiway is unpaved the lines of lights shall be not less than 50 nor more than 100 feet apart; or

(b) where aircraft manœuvring on the ground are not confined to taxiways, white lights visible from all directions above the horizontal and of an intensity of not less than 10 candles at 5° above the horizontal, spaced at intervals not exceeding 300 feet along the boundary of that part of the aerodrome provided for the use of aircraft and under the control of the person in charge of the aerodrome and intended for use by night.

Areas Unfit for Use

52. The lighting required by Rule 48 of these Rules shall include red lights visible from all directions above the horizontal, sufficient to mark adequately any area unfit for the movement of aircraft at night.

Landing Direction Indicator

53. Where neither the lighting specified in Rule 49(a) of these Rules nor that specified in Rule 50(1)(b) of these Rules is provided the lighting required by Rule 48 of these Rules shall include—

(a) adequate illumination of a landing T as specified in Rule 40(2) of these Rules; or

(b) a landing T of the dimensions so specified, consisting of white lights, visible from all directions above the horizontal, of an intensity of not less than 5 nor more than 20 candles placed either in the signals area or between 50 and 100 feet to the left as seen from the direction of approach of the runway at the approach end thereof.

Obstruction Lights

54.—(1) The lighting required by Rule 48 of these Rules shall include the lighting of all obstructions within the area in accordance with the provisions of this Rule.

(2) The lights on an obstruction shall be arranged so as to show not less than 10 candles of red light in all directions in azimuth between 20° below and 60° above the horizontal.

(3) The lights shall be placed at the highest point of the obstruction except that, where the top of a chimney or other obstruction may be obscured by smoke, the lights may be placed instead not more than 10 feet below the top of the obstruction.

(4) If the height of an obstruction is more than 150 feet above ground level lights shall be placed on the obstruction between the top and the ground at vertical intervals not exceeding 150 feet.

(5) On any obstruction of more than 150 feet in horizontal extent lights as specified in paragraph (3) of this Rule shall be placed on the highest point of each length of 150 feet of the obstruction, measuring from one end of the obstruction.

(6) For the purposes of this Rule any object, whether permanent or temporary, shall be deemed to be an obstruction if it is likely to endanger aircraft and if it is situated—

- (a) on that part of the manœuvring area which is intended for use at night ; or
- (b) within an area extending 200 feet on either side of the centre line of the area intended for landing or take-off at night ; or
- (c) within 200 feet of the area so intended, if the height of the object is more than one quarter of the distance of the object from that area ; or
- (d) within 50 feet of a lighted taxiway ; or
- (e) within an area of the dimensions illustrated in this sub-paragraph,

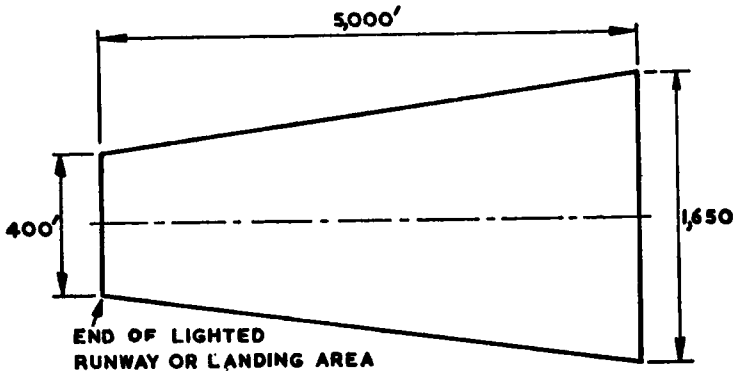

Fig. 20.

being an area at either end of a lighted runway or lighted landing area and if the height of the object, measured above the level of the nearer end of the runway or landing area, is more than one thirtieth of the distance from the object to the nearest end of the runway or landing area :

Provided that a frangible object not more than 3 feet in height above ground shall not be deemed to be an obstruction by reason of this sub-paragraph ; or

- (f) within one nautical mile of the centre of the area intended for use at night for the taking off, landing or manœuvring of aircraft on the ground and more than 300 feet above the highest point of the ground within that area.
- (7) Nothing in this Rule shall be taken to require the lighting of—
 - (a) any aircraft displaying navigation lights in accordance with Section III of these Rules ;
 - (b) in an area set aside for the parking of aircraft, any vehicle which is displaying the lights which are obligatory when it is being driven on a public highway ;
 - (c) any obstruction or part of an obstruction which, by reason of the lighting of other obstructions, is not likely to endanger aircraft in flight.

SECTION XI

AIR TRAFFIC CONTROL

Provision of Air Traffic Control Services

55.—(1) At every aerodrome (other than a Government aerodrome) which is provided with means of two-way radio communication with aircraft and is either situated in a control zone or is an aerodrome in respect of which the Board have

given a direction to the proprietor or person in charge of the aerodrome requiring air traffic control service to be provided there, the person in charge of the aerodrome shall cause air traffic control service to be provided at all times when the aerodrome is open for the take-off and landing of aircraft.

(2) At every aerodrome (other than a Government aerodrome) which is provided with means of two-way radio communication with aircraft and with equipment for providing holding aid, let-down aid or approach aid by radio or radar the person in charge of the aerodrome shall inform the Board in advance of any period during which any of the said equipment will be in operation for the purpose of providing holding aid, let-down aid or approach aid and, without prejudice to paragraph (1) of this Rule, cause air traffic control service to be provided at all times when the said equipment is notified as being in operation for any of those purposes.

Licensing of Air Traffic Controllers and Student Air Traffic Controllers

56.—(1) The Board may grant a licence subject to such conditions as they think fit to any person to act as an air traffic controller, or as a student air traffic controller, upon their being satisfied that the applicant is a fit and proper person to hold the licence and is qualified by reason of his knowledge, experience, competence, skill and physical fitness so to act, and for that purpose the applicant shall furnish such evidence and undergo such examinations and tests (including in particular medical examinations) as the Board may require of him:

Provided that the Board shall not grant a licence to act as an air traffic controller to a person under the age of 21 years or a licence to act as a student air traffic controller to a person under the age of 18 years.

(2) Every licence to act as an air traffic controller shall include ratings of one or more of the classes set forth in Rule 58 of these Rules specifying the type of air traffic control service which the holder of the licence is competent to provide, and a list of the places at which, and the type of radar equipment, if any, with the aid of which he may provide the service. If throughout any period of 90 days the holder of the licence has not at any time provided at a particular place the type of air traffic control service specified in the rating, the rating shall, without prejudice to the Board's powers under Article 56 of the Order, cease to be valid for that place at the end of that period, and upon a rating ceasing to be valid for a place the holder of the licence shall forthwith inform the Board to that effect and shall forward the licence to the Board to enable it to be endorsed accordingly.

(3) Every licence to act as a student air traffic controller shall be valid only for the purpose of authorising the holder to provide air traffic control service under the supervision of another person who is present at the time and is the holder of a valid air traffic controller's licence which includes a rating specifying the type of air traffic control service which is being provided by the student air traffic controller, and valid at the place in question.

(4) A licence as an air traffic controller or as a student air traffic controller shall not be valid unless the holder of the licence has signed his name thereon in ink with his ordinary signature.

(5) Subject to the provisions of Article 56 of the Order, a licence as an air traffic controller or as a student air traffic controller shall remain in force for a period of 12 months and may be renewed by the Board from time to time upon their being satisfied that the applicant is a fit and proper person and is qualified as aforesaid.

Prohibition of Unlicensed Air Traffic Controllers and Student Air Traffic Controllers

57.—(1) A person shall not provide any type of air traffic control service at any aerodrome at which air traffic control service is required to be provided by or under Rule 55 of these Rules or at any Government aerodrome or at any other place (not being an aerodrome) at which air traffic control service is provided

(whether or not under the direction of a Government Department or visiting force) unless he does so under and in accordance with the terms of—

- (a) a valid student air traffic controller's licence granted under these Rules and he is supervised in accordance with Rule 56(3) of these Rules ; or
- (b) a valid air traffic controller's licence so granted authorising him to provide that type of service at that aerodrome or other place ; or
- (c) a valid air traffic controller's licence so granted which does not authorise him to provide that type of service at that aerodrome or other place, but he is supervised by a person who is present at the time and who is the holder of a valid air traffic controller's licence so granted which authorises him to provide at that aerodrome or other place the type of air traffic control service which is being provided ; or
- (d) his appointment by the Board as an air traffic control officer cadet and he is supervised by a person who is present at the time and who is the holder of a valid air traffic controller's licence so granted which authorises him to provide that type of service at a Government aerodrome or at a place at which air traffic control service is provided under the direction of a Government Department :

Provided that a licence shall not be required by any person who acts in the course of his duty as a member of any of Her Majesty's naval, military or air forces or a visiting force.

(2) The holder of a licence shall not be entitled to perform any of the functions specified in Rule 58 of these Rules in respect of a rating at any of the places referred to in paragraph (1) of this Rule unless his licence includes that rating and the rating is valid for the place at which, and the type of radar equipment if any with the aid of which, the functions are performed.

(3) The holder of a licence which includes ratings of two or more of the classes specified in Rule 58 of these Rules shall not at any one time perform the function specified in respect of more than one of those ratings :

Provided that the functions of any one of the following groups of ratings may be exercised at the same time :

- (a) The Aerodrome Control Rating and the Approach Control Rating ;
- (b) The Approach Control Rating and the Approach Radar Control Rating ;
- (c) The Area Control (I) Rating and the Area Radar Control Rating ;
- (d) The Area Control (II) Rating and the Area Radar Control Rating ;
- (e) The Area Control (I) Rating and the Area Control (II) Rating.

(4) Nothing in a licence granted under Rule 56 of these Rules shall permit any person to operate manually any direction-finding equipment for the purpose of providing air traffic control service to an aircraft at a time when he is providing air traffic control service or making signals to that aircraft or to another aircraft.

(5) Nothing in this Rule shall prohibit the holder of a valid air traffic controller's licence from providing, at any place for which the licence includes a valid rating, information to aircraft in flight in the interests of safety.

Air Traffic Controller's Licence—Ratings

58. Ratings of the following classes may be included in an air traffic controller's licence (other than a student air traffic controller's licence) granted under Rule 56 of these Rules and, subject to the provisions of these Regulations and of the licence, the inclusion of a rating in a licence shall have the consequences respectively specified as follows :

(1) *Aerodrome Control Rating* shall entitle the holder of the licence, at any aerodrome for which the rating is valid, to provide air traffic control service (but not with any type of radar equipment for which a radar control rating is required under this Rule) for any aircraft on the manœuvring area or apron of that aero-

drome or which is flying in the vicinity of the aerodrome traffic zone by visual reference to the surface.

(2) *Approach Control Rating* shall entitle the holder of the licence, at any aerodrome for which the rating is valid, to provide air traffic control service (but not with any type of radar equipment for which a radar control rating is required under this Rule) for any aircraft which is flying in the vicinity of the aerodrome traffic zone whether or not it is flying by visual reference to the surface.

(3) *Approach Radar Control Rating* shall entitle the holder of the licence, at any aerodrome for which the rating is valid, to provide air traffic control service with the aid of any type of surveillance radar equipment for which the rating is valid for aircraft flying in circumstances specified in paragraph (2) of this Rule.

(4) *Precision Approach Radar Control Rating* shall entitle the holder of the licence, at any aerodrome for which the rating is valid, to provide air traffic control service with the aid of any type of precision approach radar equipment for which the rating is valid.

(5) *Area Control (I) Rating* shall entitle the holder of the licence, at any place for which the rating is valid, to provide air traffic control service (but not with any type of radar equipment for which a radar control rating is required under this Rule) for aircraft in flight within controlled airspace or within airspace which has been notified as an advisory area or an advisory route.

(6) *Area Control (II) Rating* shall entitle the holder of the licence, at any place for which the rating is valid, to provide air traffic control service (but not with any type of radar equipment for which a radar control rating is required under this Rule) for aircraft in flight outside controlled airspace.

(7) *Area Radar Control Rating* shall entitle the holder of the licence, at any place for which the rating is valid, to provide air traffic control service with the aid of any type of surveillance radar equipment for which the rating is valid.

(8) *Area Control Rating* shall entitle the holder of the licence, at any place for which the rating is valid, to provide air traffic control service with the aid of any type of surveillance radar equipment for which the rating is valid, or without the aid of any surveillance radar equipment.

Incapacity of Air Traffic Controllers

59.—(1) Every holder of an air traffic controller's licence granted under Rule 56 of these Rules who—

(a) suffers any personal injury or illness involving incapacity to undertake the functions to which his licence relates throughout a period of twenty consecutive days ; or

(b) in the case of a woman, has reason to believe that she is pregnant, shall inform the Board in writing of such injury, illness or pregnancy as soon as possible.

(2) An air traffic controller's licence shall be deemed to be suspended upon the elapse of such period of injury or illness as is referred to in paragraph (1) (a) of this Rule. The suspension of the licence shall cease:

(a) upon the holder being medically examined under arrangements made by the Board and pronounced fit to resume his functions under the licence ; or

(b) upon the Board exempting the holder from the requirement of a medical examination subject to such conditions as the Board may think fit.

(3) Upon the pregnancy of the holder of an air traffic controller's licence being confirmed, the licence shall be deemed to be suspended and shall remain suspended until she has been medically examined after the pregnancy has ended and pronounced fit to resume her functions under the licence.

EXPLANATORY NOTE

(This Note is not part of the Regulations.)

These Regulations consolidate the Rules of the Air and Air Traffic Control Regulations 1966, as amended, with minor drafting amendments. The only material amendment is the deletion of the special rules for Bovingdon Airport.

The Rules of the Air and Air Traffic Control, scheduled to the Regulations, make provision, applying to all civil aircraft within the United Kingdom, and all aircraft registered in the United Kingdom wherever they may be, in respect of:—

- (a) The mis-use of signals and markings (Rule 3).
- (b) The reporting of hazardous conditions in flight (Rule 4).
- (c) Low flying (Rule 5).
- (d) Simulated instrument flight (Rule 6).
- (e) Practice instrument approaches (Rule 7).
- (f) Lights and other signals to be shown or made by aircraft (Rules 8 to 15).
- (g) The carriage of secondary surveillance radar transponders (Rule 16).
- (h) The use of weather reports and forecasts (Rule 17).
- (i) Rules for avoiding aerial collisions (Rules 18 to 20).
- (j) Notification of arrival at planned destination (Rule 21).
- (k) Visual and instrument flight rules (Rules 22 to 29).
- (l) Aerodrome traffic rules, including special rules for particular aerodromes (Rules 30 to 37).
- (m) Rules for low-level cross-Channel air traffic (Rule 38).
- (n) Aerodrome signals and markings (Rules 39 to 45).
- (o) Distress, urgency, safety and warning signals (Rules 46 and 47).
- (p) Ground lighting (Rules 48 to 54).
- (q) The provision of air traffic control services, including the licensing of air traffic controllers (Rules 55 to 59).