

---

*Status: Point in time view as at 31/03/2009.*

*Status: This revised version has been created from an electronic version contributed by Westlaw which was originally derived from the printed publication. **Read more** (See end of Document for details)**Changes to legislation:** There are currently no known outstanding effects for the The Road Vehicles (Construction and Use) Regulations 1986. (See end of Document for details)*

---

---

## STATUTORY INSTRUMENTS

---

# 1986 No. 1078

## ROAD TRAFFIC

### The Road Vehicles (Construction and Use) Regulations 1986

<i>Made</i>	- - - -	<i>25th June 1986</i>
<i>Laid before Parliament</i>		<i>18th July 1986</i>
<i>Coming into Operation</i>		<i>11th August 1986</i>

The Secretary of State for Transport (hereinafter referred to as “the Secretary of State”), in exercise of the powers conferred by sections 34(5), 40(1), (2) and (3) and 172 of the Road Traffic Act 1972 now vested in him<sup>(1)</sup> and of all other enabling powers, and after consultation with representative organisations in accordance with the provisions of section 199(2) of that Act, hereby makes the following Regulations:—

## PART I PRELIMINARY

### Commencement and citation

1. These Regulations shall come into operation on 11th August 1986, and may be cited as the Road Vehicles (Construction and Use) Regulations 1986.

---

#### Commencement Information

**I1** [Reg. 1](#) in force at 11.8.1986, see [reg. 1](#)

### Revocation

2. The Regulations specified in Schedule 1 are hereby revoked.

---

#### Commencement Information

**I2** [Reg. 2](#) in force at 11.8.1986, see [reg. 1](#)

---

(1) S.I. 1979/571 and 1981/238.

**Status:** Point in time view as at 31/03/2009.

**Status:** This revised version has been created from an electronic version contributed by Westlaw which was originally derived from the printed publication. **Read more** (See end of Document for details)**Changes to legislation:** There are currently no known outstanding effects for the The Road Vehicles (Construction and Use) Regulations 1986. (See end of Document for details)

## Interpretation

3.—(1) In these Regulations, unless the context otherwise requires—

- (a) any reference to a numbered regulation or a numbered Schedule is a reference to the regulation or Schedule bearing that number in these Regulations,
- (b) any reference to a numbered or lettered paragraph or sub-paragraph is a reference to the paragraph or sub-paragraph bearing that number or letter in the regulation or Schedule or (in the case of a sub-paragraph) paragraph in which the reference occurs, and
- (c) any reference to a Table, or to a numbered Table, is a reference to the Table, or to the Table bearing that number, in the regulation or Schedule in which that reference occurs.

(2) In these Regulations, unless the context otherwise requires, the expressions specified in column 1 of the Table have the meaning, or are to be interpreted in accordance with the provisions, specified for them in column 2 of the Table.

### TABLE

(regulation 3(2))

<i>1</i> <i>Expression</i>	<i>2</i> <i>Meaning</i>
The 1971 Act	The Vehicles (Excise) Act 1971.
The 1972 Act	The Road Traffic Act 1972.
The 1981 Act	The Public Passenger Vehicles Act 1981.
The 1984 Act	The Road Traffic Regulation Act 1984 .
The Approval Marks Regulations	The Motor Vehicles (Designation of Approval Marks) Regulations 1979(2).
[ <sup>F1</sup> The EC Whole Vehicle Type Approval Regulations	The Motor Vehicles (EC Type Approval) Regulations 1998]
The Lighting Regulations	The Road Vehicles Lighting Regulations 1984.
The Plating and Testing Regulations	The Goods Vehicles (Plating and Testing) Regulations 1982(3).
The Type Approval Regulations	The Motor Vehicles (Type Approval) Regulations 1980(4).
The Type Approval (Great Britain) Regulations	The Motor Vehicles (Type Approval) (Great Britain) Regulations 1984 (5).
The Type Approval for Goods Vehicles Regulations	The Motor Vehicles (Type Approval for Goods Vehicles) (Great Britain) Regulations 1982(6).

(2) The amending instruments are S.I. 1980/582 and 2027, 1981/126 and 1732, 1982/1479, 1983/1602 and 1985/113.

(3) The amending instruments are S.I. 1983/239 and 1800, 1984/178, 816 and 1024 and 1985/44.

(4) The amending instruments are S.I. 1982/7 and 1623, 1984/1927 and 1985/1072.

(5) The amending instruments are S.I. 1984/1401 and 1761 and 1985/1651.

(6) The amending instruments are S.I. 1984/697 and 1402 and 1985/46.

**Status:** This revised version has been created from an electronic version contributed by Westlaw which was originally derived from the printed publication. **Read more** (See end of Document for details)**Changes to legislation:** There are currently no known outstanding effects for the The Road Vehicles (Construction and Use) Regulations 1986. (See end of Document for details)

<i>1</i> Expression	<i>2</i> Meaning
The Type Approval for Agricultural Vehicles Regulations	The Agricultural or Forestry Tractors and Tractor Components (Type Approval) Regulations 1979(7).
The Act of Accession	the Treaty concerning the Accession of the Kingdom of Denmark, Ireland, the Kingdom of Norway and the United Kingdom of Great Britain and Northern Ireland to the European Economic Community and the European Atomic Energy Community(8)
[ <sup>F2</sup> agricultural or forestry tractor	an agricultural or forestry tractor within the meaning of Community Directive 82/890.]
agricultural motor vehicle	a motor vehicle which is constructed or adapted for use off roads for the purpose of agriculture, horticulture or forestry and which is primarily used for one or more of those purposes, not being a dual-purpose vehicle.
agricultural trailer	a trailer which is constructed or adapted for the purpose of agriculture, horticulture or forestry and which is only used for one or more of those purposes, not being an agricultural trailed appliance.
agricultural trailed appliance	a trailer— <ul style="list-style-type: none"> <li>(a) which is an implement constructed or adapted— <ul style="list-style-type: none"> <li>(i) for use off roads for the purpose of agriculture, horticulture or forestry and which is only used for one or more of those purposes, and</li> <li>(ii) so that, save in the case of an appliance manufactured before 1st December 1985, or a towed roller, its maximum gross weight is not more than twice its unladen weight; but</li> </ul> </li> <li>(b) which is not— <ul style="list-style-type: none"> <li>(i) a vehicle which is used primarily as living accommodation by one or more persons, and which carries no goods or burden except those needed by such one or more persons for the purpose of their residence in the vehicle; or</li> <li>(ii) an agricultural, horticultural or forestry implement rigidly but not permanently mounted on any vehicle whether or not any of the weight of the implement is supported by one or more of its own wheels; so however that such an implement is an agricultural trailed appliance if <ul style="list-style-type: none"> <li>—part of the weight of the implement is supported by one or more of its own wheels, and</li> <li>—the longitudinal axis of the greater part of the implement is capable of articulating in the horizontal plane in relation to the longitudinal axis of the rear portion of the vehicle on which it is mounted.</li> </ul> </li> </ul> </li> </ul>
agricultural trailed appliance conveyor	an agricultural trailer which— <ul style="list-style-type: none"> <li>(a) has an unladen weight which does not exceed 510 kg;</li> <li>(b) is clearly and indelibly marked with its unladen weight;</li> </ul>

(7) The amending instruments are S.I. 1981/669 and 1983/709.

(8) Cmnd. 5179–1.

**Status:** Point in time view as at 31/03/2009.

**Status:** This revised version has been created from an electronic version contributed by Westlaw which was originally derived from the printed publication. **Read more** (See end of Document for details)**Changes to legislation:** There are currently no known outstanding effects for the The Road Vehicles (Construction and Use) Regulations 1986. (See end of Document for details)

<i>1</i> Expression	<i>2</i> Meaning
	(c) has a pneumatic tyre fitted to each one of its wheels;
	(d) is designed and constructed for the purpose of conveying one agricultural trailed appliance or one agricultural, horticultural or forestry implement.
[ <sup>F3</sup> anti-lock braking system (“ABS”)]	a part of a service braking system which automatically controls the degree of slip, in the direction of rotation of the wheel or wheels, on one or more wheels of the vehicle during braking.]
articulated bus	a bus so constructed that—  (a) it can be divided into two parts, both of which are vehicles and one of which is a motor vehicle, but cannot be so divided without the use of facilities normally available only at a workshop; and  (b) passengers carried by it can at all times pass from either part to the other.
articulated vehicle	a heavy motor car or motor car, not being an articulated bus, with a trailer so attached that part of the trailer is superimposed on the drawing vehicle and, when the trailer is uniformly loaded, not less than 20% of the weight of its load is borne by the drawing vehicle.
axle	any reference to the number of axles of a vehicle is to be interpreted in accordance with paragraph (8).
axle weight	in relation to each axle of a vehicle, the sum of the weights transmitted to the road surface by all the wheels of that axle, having regard to the provisions of paragraph (8).
braking efficiency	the maximum braking force capable of being developed by the brakes of a vehicle, expressed as a percentage of the weight of the vehicle including any persons or load carried in the vehicle.
braking system	is to be interpreted in accordance with paragraph (6).
bus	a motor vehicle which is constructed or adapted to carry more than eight seated passengers in addition to the driver.
[ <sup>F4</sup> car transporter]	a trailer which is constructed and normally used for the purpose of carrying at least two other wheeled vehicles.]
cc	cubic centimetre(s).
close-coupled	in relation to wheels on the same side of a trailer, fitted so that at all times while the trailer is in motion they remain parallel to the longitudinal axis of the trailer, and that the distance between the centres of their respective areas of contact with the road surface does not exceed 1 m.
<sup>F5</sup>	<sup>F5</sup>
...	...
cm	centimetre(s).
cm <sup>2</sup>	square centimetre(s).

**Status:** This revised version has been created from an electronic version contributed by Westlaw which was originally derived from the printed publication. **Read more** (See end of Document for details)**Changes to legislation:** There are currently no known outstanding effects for the The Road Vehicles (Construction and Use) Regulations 1986. (See end of Document for details)

<i>1</i> Expression	<i>2</i> Meaning
[ <sup>F6</sup> coach	means a large bus with a maximum gross weight of more than 7.5 tonnes and with a maximum speed exceeding 60 mph;]
Community Directive, followed by a number	the Directive adopted by the Council or the Commission of the European Communities [ <sup>F7</sup> or the European Parliament and the Council of the European Union] of which identifying particulars are given in the item in column 3 of Table I in Schedule 2 in which that number appears in column 2; where such a Directive amends a previous Directive mentioned in column 3(d) of the Table [ <sup>F8</sup> the reference to the amending Directive includes a reference to] that previous Directive as so amended.  Any reference to a Directive which has been amended by the Act of Accession is a reference to the Directive as so amended.
the Community Recording Equipment Regulation	[ <sup>F9</sup> Council Regulation (EEC) 3821/85 of 20th December 1985 on recording equipment in road transport, as read with the Community Drivers' Hours and Recording Equipment (Exemptions and Supplementary Provisions) Regulations 1986.]
[ <sup>F10</sup> combined transport operation	shall be construed in accordance with paragraph 9 of Schedule 11A.]
composite trailer	a combination of a converter dolly and a semi-trailer.
container	an article of equipment, not being a motor vehicle or trailer, having a volume of at least 8 cubic metres, constructed wholly or mostly of metal and intended for repeated use for the carriage of goods or burden.
converter dolly	(a) [ <sup>F11</sup> a trailer which is— (i) equipped with 2 or more wheels, (ii) designed to be used in combination with a semi-trailer without any part of the weight of the semi-trailer being borne by the drawing vehicle, and (iii) not itself a part either of the semi-trailer or the drawing vehicle when being so used; or (b) a trailer which is— (i) equipped with 2 or more wheels; (ii) designed to be used in combination with a semi-trailer with part of the weight of the semi-trailer being borne by the drawing vehicle; (iii) not itself a part either of the semi-trailer or the drawing vehicle when being so used; and (iv) used solely for the purposes of agriculture, horticulture or forestry, or for any two or for all of those purposes.]
Council Regulation (EEC), followed by a number	the Regulation adopted by the Council of the European Communities.
deck	a floor or platform on which seats are provided for the accommodation of passengers.
design weight	in relation to the gross weight, each axle weight or the train weight of a motor vehicle or trailer, the weight at or below which in the opinion

**Status:** Point in time view as at 31/03/2009.

**Status:** This revised version has been created from an electronic version contributed by Westlaw which was originally derived from the printed publication. **Read more** (See end of Document for details)**Changes to legislation:** There are currently no known outstanding effects for the The Road Vehicles (Construction and Use) Regulations 1986. (See end of Document for details)

<i>1</i> Expression	<i>2</i> Meaning
	of the Secretary of State or of a person authorised in that behalf by the Secretary of State the vehicle could safely be driven on roads.
double-decked vehicle	a vehicle having two decks one of which is wholly or partly above the other and each of which is provided with a gangway serving seats on that deck only.
dual-purpose vehicle	a vehicle constructed or adapted for the carriage both of passengers and of goods or burden of any description, being a vehicle of which the unladen weight does not exceed 2040 kg, and which either— <ul style="list-style-type: none"> <li>(i) is so constructed or adapted that the driving power of the engine is, or by the appropriate use of the controls of the vehicle can be, transmitted to all the wheels of the vehicle; or</li> <li>(ii) satisfies the following conditions as to construction, namely— <ul style="list-style-type: none"> <li>(a) the vehicle must be permanently fitted with a rigid roof, with or without a sliding panel;</li> <li>(b) the area of the vehicle to the rear of the driver's seat must— <ul style="list-style-type: none"> <li>(i) be permanently fitted with at least one row of transverse seats (fixed or folding) for two or more passengers and those seats must be properly sprung or cushioned and provided with upholstered back-rests, attached either to the seats or to a side or the floor of the vehicle; and</li> <li>(ii) be lit on each side and at the rear by a window or windows of glass or other transparent material having an area or aggregate area of not less than 1850 square centimetres on each side and not less than 770 square centimetres at the rear; and</li> </ul> </li> <li>(c) the distance between the rearmost part of the steering wheel and the back-rests of the row of transverse seats satisfying the requirements specified in head (i) of sub-paragraph (b) (or, if there is more than one such row of seats, the distance between the rearmost part of the steering wheel and the back-rests of the rearmost such row) must, when the seats are ready for use, be not less than one-third of the distance between the rearmost part of the steering wheel and the rearmost part of the floor of the vehicle.</li> </ul> </li> </ul>
ECE Regulation, followed by a number	the Regulation, annexed to the Agreement concerning the adoption of uniform conditions of approval for Motor Vehicles Equipment and Parts and reciprocal recognition thereof concluded at Geneva on 20th March 1958 <sup>(9)</sup> as amended <sup>(10)</sup> , to which the United Kingdom is a party <sup>(11)</sup> , of which identifying particulars are given in the item in column (3)(a), (b) and (c) of Table II in Schedule 2 in which that number appears in column (2); and where that number contains more than two digits, it refers to that Regulation with the amendments in force at the date specified in column (3)(d) in that item.

<sup>(9)</sup> Cmnd. 2535.

<sup>(10)</sup> Cmnd. 3562.

<sup>(11)</sup> By instrument of accession dated 14th January 1963 deposited with the Secretary General of the United Nations on 15th January 1963.

<i>1</i> Expression	<i>2</i> Meaning
engine power in kilowatts (kW)	the maximum net power ascertained in accordance with Community Directive 80/1269.
[ <sup>F4</sup> engineering equipment	engineering plant and any other plant or equipment designed and constructed for the purpose of engineering operations.]
engineering plant	(a) movable plant or equipment being a motor vehicle or trailer specially designed and constructed for the special purposes of engineering operations, and which cannot, owing to the requirements of those purposes, comply with all the requirements of these Regulations and which is not constructed primarily to carry a load other than a load being either excavated materials raised from the ground by apparatus on the motor vehicle or trailer or materials which the vehicle or trailer is specially designed to treat while carried thereon; or  (b) a mobile crane which does not comply in all respects with the requirements of these Regulations.
exhaust system	a complete set of components through which the exhaust gases escape from the engine unit of a motor vehicle including those which are necessary to limit the noise caused by the escape of those gases.
first used	is to be interpreted in accordance with paragraph (3).
[ <sup>F12</sup> Framework Directive	Council Directive <a href="#">70/156/EEC</a> as amended by Council Directive <a href="#">87/403/EEC</a> , Council Directive <a href="#">92/53/EEC</a> [ <sup>F13</sup> , Commission Directive <a href="#">93/81/EEC</a> and Commission Directive <a href="#">98/14/EC</a> ].]
gangway	the space provided for obtaining access from any entrance to the passengers' seats or from any such seat to an exit other than an emergency exit, but excluding a staircase and any space in front of a seat which is required only for the use of passengers occupying that seat or a seat in the same row of seats.
gas	any fuel which is wholly gaseous at 17.5°C under a pressure of 1.013 bar absolute.
gas-fired appliance	a device carried on a motor vehicle or trailer when in use on a road, which consumes gas and which is neither—  (a) a device owned or operated by or with the authority of the British Gas Corporation for the purpose of detecting gas, nor  (b) an engine for the propulsion of a motor vehicle, nor  (c) a lamp which consumes acetylene gas.
goods vehicle	a motor vehicle or trailer constructed or adapted for use for the carriage or haulage of goods or burden of any description.
gritting trailer	a trailer which is used on a road for the purpose of spreading grit or other matter so as to avoid or reduce the effect of ice or snow on the road.
gross weight	(a) in relation to a motor vehicle, the sum of the weights transmitted to the road surface by all the wheels of the vehicle.

**Status:** Point in time view as at 31/03/2009.

**Status:** This revised version has been created from an electronic version contributed by Westlaw which was originally derived from the printed publication. **Read more** (See end of Document for details) **Changes to legislation:** There are currently no known outstanding effects for the The Road Vehicles (Construction and Use) Regulations 1986. (See end of Document for details)

<i>1</i> Expression	<i>2</i> Meaning
heavy motor car	(b) in relation to a trailer, the sum of the weights transmitted to the road surface by all the wheels of the trailer and of any weight of the trailer imposed on the drawing vehicle.  a mechanically propelled vehicle, not being a locomotive, a motor tractor, or a motor carry, which is constructed itself to carry a load or passengers and the weight of which unladen exceeds 2540 kg.
indivisible load	a load which cannot without undue expense or risk of damage be divided into two or more loads for the purpose of conveyance on a road.
industrial tractor	a tractor, not being an agricultural motor vehicle, which—  (a) has an unladen weight not exceeding 7370 kg,  (b) is designed and used primarily for work off roads, or for work on roads in connection only with road construction or maintenance (including any such tractor when fitted with an implement or implements designed primarily for use in connection with such work, whether or not any such implement is of itself designed to carry a load), and  (c) has a maximum speed not exceeding 20 mph.
invalid carriage	a mechanically propelled vehicle the weight of which unladen does not exceed 254 kg and which is specially designed and constructed, and not merely adapted, for the use of a person suffering from some physical defect or disability and is solely used by such a person.
[ <sup>F3</sup> ISO	International Organisation for Standardisation.]
[ <sup>F3</sup> ISO 7638 connector	an electrical connector that complies with standard ISO 7638: 1997–1 or ISO 7638: 1997–2 and is used to provide a dedicated power supply and a communication link between the tow vehicle and trailer.]
kerbside weight	the weight of a vehicle when it carries— (a) in the case of a motor vehicle, (i) no person; and (ii) a full supply of fuel in its tank, an adequate supply of other liquids incidental to its propulsion and no load other than the loose tools and equipment with which it is normally equipped; (b) in the case of a trailer, no person and is otherwise unladen.
kg	kilogram(s).
km/h	kilometre(s) per hour.
kW	kilowatt(s).
[ <sup>F6</sup> large bus	means a vehicle constructed or adapted to carry more than 16 seated passengers in addition to the driver;]
[ <sup>F14</sup> light trailer	a trailer with a maximum gross weight which does not exceed 3500 kg.]
living van	a vehicle used primarily as living accommodation by one or more persons, and which is not also used for the carriage of goods or burden



<i>1</i> Expression	<i>2</i> Meaning
	which are not needed by such one or more persons for the purpose of their residence in the vehicle.
locomotive	a mechanically propelled vehicle which is not constructed itself to carry a load other than the following articles, that is to say, water, fuel, accumulators and other equipment used for the purpose of propulsion, loose tools and loose equipment, and the weight of which unladen exceeds 7370 kg.
longitudinal plane	a vertical plane parallel to the longitudinal axis of a vehicle.
[ <sup>F15</sup> low platform trailer	a trailer fitted with tyres with a rim diameter size code of less than 20 and displaying a rectangular plate which— <ul style="list-style-type: none"> <li>(a) is at least 225 mm wide and at least 175 mm high; and</li> <li>(b) bears two black letters “L” on a white ground each at least 125 mm high and 90 mm wide with a stroke width of 12 mm.]</li> </ul>
[ <sup>F4</sup> low loader	a semi-trailer which is constructed and normally used for the carriage of engineering equipment so constructed that the major part of the load platform does not extend over or between the wheels and the upper surface of which is below the height of the top most point of the tyres of those wheels, measured on level ground and when— <ul style="list-style-type: none"> <li>(a) any adjustable suspension is at the normal travelling height,</li> <li>(b) all pneumatic tyres are suitably inflated for use when the vehicle is fully laden, and</li> <li>(c) the semi-trailer is unladen,</li> </ul> (see also the definition of stepframe low loader). ]
m	metre(s).
m <sup>2</sup>	square metre(s).
m <sup>3</sup>	cubic metre(s).
[ <sup>F16</sup> maximum permitted axle weight	in relation to an axle— <ul style="list-style-type: none"> <li>(a) in the case of a vehicle which is equipped with a Ministry plate in accordance with regulation 70, the axle weight shown in column (2) of that plate (where the plate is in the form required by [<sup>F17</sup>Schedule 10 or 10B]) or in column (2) of that plate (where the plate is in the form required by [<sup>F17</sup>Schedule 10A or 10C]) in relation to that axle;</li> <li>(b) in the case of a vehicle which is not equipped with a Ministry plate but which is equipped with a plate in accordance with regulation 66, the maximum axle weight shown for that axle on the plate in respect of item 9 of Part I of Schedule 8 in the case of a motor vehicle and item 7 of Part II of Schedule 8 in the case of a trailer; and</li> <li>(c) in any other case, the weight which the axle is designed or adapted not to exceed when the vehicle is travelling on a road.]</li> </ul>

**Status:** Point in time view as at 31/03/2009.

**Status:** This revised version has been created from an electronic version contributed by Westlaw which was originally derived from the printed publication. **Read more** (See end of Document for details)**Changes to legislation:** There are currently no known outstanding effects for the The Road Vehicles (Construction and Use) Regulations 1986. (See end of Document for details)

<i>1</i> Expression	<i>2</i> Meaning
maximum gross weight	<p>(a) in the case of a vehicle equipped with a Ministry plate in accordance with regulation 70, the design gross weight shown in column (3) of that plate or, if no such weight is shown, the gross weight shown in column (2) of that plate [<sup>F18</sup>(where the plate is in the form required by [<sup>F17</sup>Schedule 10 or 10B]) or in column (4) of that plate (where the plate is in the form required by [<sup>F17</sup>Schedule 10A or 10C)].];</p> <p>(b) in the case of a vehicle not equipped with a Ministry plate, but which is equipped with a plate in accordance with regulation 66, the maximum gross weight shown on the plate in respect of item 7 of Part 1 of Schedule 8 in the case of a motor vehicle and item 6 of Part II of Schedule 8 in the case of a trailer;</p> <p>(c) in any other case, the weight which the vehicle is designed or adapted not to exceed when the vehicle is travelling on a road.</p>
[ <sup>F19</sup> maximum total design axle weight (an expression used only in relation to trailers)	<p>(a) (a) in the case of a trailer equipped with a Ministry plate in accordance with regulation 70, the sum of the relevant axle weights;</p> <p>(b) in the case of a trailer which is not equipped with a Ministry plate, but which is equipped with a plate in accordance with regulation 66, the sum of the maximum axle weights shown on the plate in respect of item 4 of Part II of Schedule 8; or</p> <p>(c) in the case of any other trailer, the sum of the axle weights which the trailer is designed or adapted not to exceed when the vehicle is travelling on a road;</p> <p>and for the purposes of sub-paragraph (a) the relevant axle weight, in respect to an axle, is the design axle weight shown in column (3) of the Ministry plate (where the plate is in the form required by [<sup>F17</sup>Schedule 10 or 10B]) or in column (4) of that plate (where the plate is in the form required by [<sup>F17</sup>Schedule 10A or 10C]) in relation to that axle or if no such weight is shown, the axle weight shown in column (2) of that plate in relation to that axle;]</p>
maximum speed	the speed which a vehicle is incapable, by reason of its construction, of exceeding on the level under its own power when fully laden.
minibus	a motor vehicle which is constructed or adapted to carry more than 8 but not more than 16 seated passengers in addition to the driver.
Ministry plate	[ <sup>F20</sup> is to be interpreted in accordance with regulation 70.]
mm	millimetre(s).
motor ambulance	a motor vehicle which is specially designed and constructed (and not merely adapted) for carrying, as equipment permanently fixed to the vehicle, equipment used for medical, dental, or other health purposes and is used primarily for the carriage of persons suffering from illness, injury or disability.

<i>1</i> Expression	<i>2</i> Meaning
motor car	<p>a mechanically propelled vehicle, not being a motor tractor, a motor cycle or an invalid carriage, which is constructed itself to carry a load or passengers and the weight of which unladen—</p> <p>(a) if it is constructed solely for the carriage of passengers and their effects and is adapted to carry not more than seven passengers exclusive of the driver does not exceed 3050 kg;</p> <p>(b) if it is constructed for use for the conveyance of goods or burden of any description, does not exceed 3050 kg;</p> <p>(c) does not exceed 2540 kg in a case falling within neither of the foregoing paragraphs.</p>
[ <sup>F6</sup> motor caravan	<p>means a motor vehicle which is constructed or adapted for the carriage of passengers and their effects and which contains, as permanently installed equipment, the facilities which are reasonably necessary for enabling the vehicle to provide mobile living accommodation for its users;]</p>
motor cycle	<p>a mechanically propelled vehicle, not being an invalid carriage, having less than four wheels and the weight of which unladen does not exceed 410 kg.</p>
motor tractor	<p>a mechanically propelled vehicle which is not constructed itself to carry a load, other than the following articles, that is to say, water, fuel, accumulators and other equipment used for the purpose of propulsion, loose tools and loose equipment, and the weight of which unladen does not exceed 7370 kg.</p>
motor vehicle	<p>a mechanically propelled vehicle intended or adapted for use on roads.</p>
mph	<p>mile(s) per hour.</p>
N/mm <sup>2</sup>	<p>newton(s) per square millimetre.</p>
[ <sup>F21</sup> off-road vehicle	<p>an off-road vehicle as defined in Annex I to Council Directive <a href="#">70/156/EEC</a> of 6th February 1970(4) as read with Council Directive <a href="#">87/403/EEC</a> of 25th June 1987(5).]</p>
overall height	<p>the vertical distance between the ground and the point on the vehicle which is furthest from the ground, calculated when—</p> <p>(a) the tyres of the vehicle are suitably inflated for the use to which it is being put;</p> <p>(b) the vehicle is at its unladen weight; and</p> <p>(c) the surface of the ground under the vehicle is reasonably flat;</p>

(4) The amending instruments are S.I. 1982/7 and 1623, 1984/1927 and 1985/1072.

(5) The amending instruments are S.I. 1984/1401 and 1761 and 1985/1651.

**Status:** Point in time view as at 31/03/2009.

**Status:** This revised version has been created from an electronic version contributed by Westlaw which was originally derived from the printed publication. **Read more** (See end of Document for details)**Changes to legislation:** There are currently no known outstanding effects for the The Road Vehicles (Construction and Use) Regulations 1986. (See end of Document for details)

<i>1</i> Expression	<i>2</i> Meaning
overall length	<p>but, in the case of a trolley bus, exclusive of the power collection equipment mounted on the roof of the vehicle.</p> <p>in relation to a vehicle, the distance between transverse planes passing through the extreme forward and rearward projecting points of the vehicle inclusive of all parts of the vehicle, of any receptacle which is of a permanent character and accordingly strong enough for repeated use, and any fitting on, or attached to, the vehicle except—</p> <p>(i) for all purposes—</p> <p>(a) any driving mirror;</p> <p>(b) any expanding or extensible contrivance forming part of a turntable fire escape fixed to a vehicle;</p> <p>(c) any snow-plough fixed in front of a vehicle;</p> <p>(d) any receptacle specially designed to hold and keep secure a seal issued for the purposes of customs clearance;</p> <p>(e) any tailboard which is let down while the vehicle is stationary in order to facilitate its loading or unloading;</p> <p>(f) any tailboard which is let down in order to facilitate the carriage of, but which is not essential for the support of, loads which are in themselves so long as to extend at least as far as the tailboard when upright;</p> <p>(g) any fitting attached to a part of, or to a receptacle on, a vehicle which does not increase the carrying capacity of the part or receptacle but which enables it to be</p> <p style="padding-left: 40px;">—transferred from a road vehicle to a railway vehicle or from a railway vehicle to a road vehicle,</p> <p style="padding-left: 40px;">—secured to a railway vehicle by a locking device, and</p> <p style="padding-left: 40px;">—carried on a railway vehicle by the use of stanchions;</p> <p>(h) any plate, whether rigid or movable, fitted to a trailer constructed for the purpose of carrying other vehicles and designed to bridge the gap between that trailer and a motor vehicle constructed for that purpose and to which the trailer is attached so that, while the trailer is attached to the motor vehicle, vehicles which are to be carried by the motor vehicle may be moved from the trailer to the motor vehicle before a journey begins, and vehicles which have been carried on the motor vehicle may be moved from it to the trailer after a journey ends;</p> <p>(i) any sheeting or other readily flexible means of covering or securing a load;</p> <p>(j) <sup>F22</sup> ...</p> <p>(k) any empty receptacle which itself forms a load;</p> <p>(l) any receptacle which contains an indivisible load of exceptional length;</p> <p>(m) <sup>F23</sup> any receptacle manufactured before 30th October 1985, not being a maritime container (namely a container designed primarily for carriage on sea transport without an accompanying road vehicle); ...</p>

<i>1</i> <i>Expression</i>	<i>2</i> <i>Meaning</i>
	<ul style="list-style-type: none"> <li>(n) any special appliance or apparatus as described in regulation 81(c) which does not itself increase the carrying capacity of the vehicle; <sup>F24</sup>or</li> <li>(o) any rearward projecting buffer made of rubber or other resilient material.]</li> </ul>
	<ul style="list-style-type: none"> <li>(ii) for the purposes of <sup>F25</sup>regulations 7, 13A, 13B and 13C]— <ul style="list-style-type: none"> <li>(a) any part of a trailer (not being in the case of an agricultural trailed appliance a drawbar or other thing with which it is equipped for the purpose of being towed) designed primarily for use as a means of attaching it to another vehicle and any fitting designed for use in connection with any such part;</li> <li>(b) the thickness of any front or rear wall on a semi-trailer and of any part forward of such front wall or rearward of such rear wall which does not increase the vehicle's load-carrying space.</li> </ul> </li> </ul>
overall width	<p>the distance between longitudinal planes passing through the extreme lateral projecting points of the vehicle inclusive of all parts of the vehicle, of any receptacle which is of permanent character and accordingly strong enough for repeated use, and any fitting on, or attached to, the vehicle except—</p> <ul style="list-style-type: none"> <li>(a) any driving mirror;</li> <li>(b) any snow-plough fixed in front of the vehicle;</li> <li>(c) so much of the distortion of any tyre as is caused by the weight of the vehicle;</li> <li>(d) any receptacle specially designed to hold and keep secure a seal issued for the purposes of customs clearance;</li> <li>(e) any lamp or reflector fitted to the vehicle in accordance with the Lighting Regulations;</li> <li>(f) any sideboard which is let down while the vehicle is stationary in order to facilitate its loading or unloading;</li> <li>(g) any fitting attached to part of, or to a receptacle on, a vehicle which does not increase the carrying capacity of the part or receptacle but which enables it to be <ul style="list-style-type: none"> <li>—transferred from a road vehicle to a railway vehicle or from a railway vehicle to a road vehicle;</li> <li>—secured to a railway vehicle by a locking device; and</li> <li>—carried on a railway vehicle by the use of stanchions;</li> </ul> </li> <li>(h) any sheeting or other readily flexible means of covering or securing a load;</li> <li>(i) any receptacle with an external width, measured at right angles to the longitudinal axis of the vehicle, which does not exceed 2.5 m;</li> <li>(j) any empty receptacle which itself forms a load;</li> <li>(k) any receptacle which contains an indivisible load of exceptional width;</li> <li>(l) <sup>F26</sup>any receptacle manufactured before 30th October 1985, not being a maritime container (namely a container designed primarily for carriage on sea transport without an accompanying road vehicle); ...</li> </ul>

**Status:** Point in time view as at 31/03/2009.

**Status:** This revised version has been created from an electronic version contributed by Westlaw which was originally derived from the printed publication. **Read more** (See end of Document for details)**Changes to legislation:** There are currently no known outstanding effects for the The Road Vehicles (Construction and Use) Regulations 1986. (See end of Document for details)

<i>1</i> <i>Expression</i>	<i>2</i> <i>Meaning</i>
	<p>(m) any special appliance or apparatus as described in regulation 81(c) which does not itself increase the carrying capacity of the vehicle [F27]; or</p> <p>(n) any apparatus fitted to a bus which enables it to be guided wholly or mainly by means of wheels bearing outwards against fixed apparatus, provided that no part of the apparatus projects more than 75mm beyond the side of the bus when the wheels of the bus are parallel to its longitudinal axis;</p> <p>and the reference in paragraph (n) above to the side of a bus is a reference to the longitudinal plane passing through the extreme lateral projecting points of the vehicle inclusive of all parts of the vehicle, of any receptacle which is of permanent character and accordingly strong enough for repeated use, and any fitting on, or attached to, the vehicle except those items referred to in paragraphs (a) to (n).]</p>
overhang	<p>the distance measured horizontally and parallel to the longitudinal axis of a vehicle between two transverse planes passing through the following two points—</p> <p>(a) the rearmost point of the vehicle exclusive of—</p> <p>(i) any expanding or extensible contrivance forming part of a turntable fire escape fixed to a vehicle;</p> <p>(ii) in the case of a motor car constructed solely for the carriage of passengers and their effects and adapted to carry not more than eight passengers exclusive of the driver, any luggage carrier fitted to the vehicle; and</p> <p>(b) (i) in the case of a motor vehicle having not more than three axles of which only one is not a steering axle, the centre point of that axle;</p> <p>(ii) in the case of a motor vehicle having three axles of which the front axle is the only steering axle and of a motor vehicle having four axles of which the two foremost are the only steering axles, a point 110 mm behind the centre of a straight line joining the centre points of the two rearmost axles; and</p> <p>(iii) in any other case a point situated on the longitudinal axis of the vehicle and such that a line drawn from it at right angles to that axis will pass through the centre of the minimum turning circle of the vehicle.</p>
passenger vehicle	a vehicle constructed solely for the carriage of passengers and their effects.
pedestrian-controlled vehicle	a motor vehicle which is controlled by a pedestrian and not constructed or adapted for use or used for the carriage of a driver or passenger.
pneumatic tyre	<p>a tyre which—</p> <p>(a) is provided with, or together with the wheel upon which it is mounted forms, a continuous closed chamber inflated to a pressure substantially exceeding atmospheric pressure when the tyre is in the condition in which it is normally used, but is not subjected to any load;</p>

**Status:** This revised version has been created from an electronic version contributed by Westlaw which was originally derived from the printed publication. **Read more** (See end of Document for details)**Changes to legislation:** There are currently no known outstanding effects for the The Road Vehicles (Construction and Use) Regulations 1986. (See end of Document for details)

<i>1</i> Expression	<i>2</i> Meaning
	<p>(b) is capable of being inflated and deflated without removal from the wheel or vehicle; and</p> <p>(c) is such that, when it is deflated and is subjected to a normal load, the sides of the tyre collapse.</p>
public works vehicle	<p>[<sup>F28</sup>a mechanically propelled vehicle which is used on a road by or on behalf of—</p> <ul style="list-style-type: none"> <li>(a) the Central Scotland Water Development Board;</li> <li>(b) a ferry undertaking;</li> <li>(c) a highway or roads authority;</li> <li>(d) a local authority;</li> <li>(e) a market undertaking;</li> <li>(f) the National Rivers Authority;</li> <li>(g) an operator of [<sup>F29</sup>an electronic communications code network];</li> <li>(h) a police authority;</li> <li>(i) [<sup>F30</sup>a universal service provider (within the meaning of the Post Services Act 2000) in connection with the provision of a universal postal service (within the meaning of that Act)];</li> <li>(j) a public electricity supplier within the meaning of Part I of the Electricity Act 1989(<b>5</b>);</li> <li>(k) [<sup>F31</sup>a public gas transporter within the meaning of Part I of the Gas Act 1986];</li> <li>(l) a statutory undertaker within the meaning of section 329(1) of the Highways Act 1980(<b>7</b>);</li> <li>(m) an undertaking for the supply of district heating;</li> <li>(n) a water authority within the meaning of the Water (Scotland) Act 1980(<b>8</b>); or</li> <li>(o) a water or sewerage undertaker within the meaning of the Water Act 1989(<b>9</b>);</li> </ul> <p>for the purpose of works which such a body has a duty or power to carry out, and which is used only for the carriage of—</p> <ul style="list-style-type: none"> <li>(i) the crew, and</li> <li>(ii) goods which are needed for works in respect of which the vehicle is used.] </li></ul>
recut pneumatic tyre	a pneumatic tyre in which all or part of its original tread pattern has been cut deeper or burnt deeper or a different tread pattern has been cut deeper or burnt deeper than the original tread pattern.
refuse vehicle	a vehicle designed for use and used solely in connection with street cleansing, the collection or disposal of refuse, or the collection or disposal of the contents of gullies or cesspools.
registered	<p>registered under any of the following enactments—</p> <p>(a) the Roads Act 1920,</p>

(5) The amending instruments are S.I. 1984/1401 and 1761 and 1985/1651.

(7) The amending instruments are S.I. 1981/669 and 1983/709.

(8) Cmnd. 5179-1.

(9) Cmnd. 2535.

**Status:** Point in time view as at 31/03/2009.

**Status:** This revised version has been created from an electronic version contributed by Westlaw which was originally derived from the printed publication. **Read more** (See end of Document for details)**Changes to legislation:** There are currently no known outstanding effects for the The Road Vehicles (Construction and Use) Regulations 1986. (See end of Document for details)

<i>1</i> <i>Expression</i>	<i>2</i> <i>Meaning</i>
	(b) the Vehicles (Excise) Act 1949,  (c) the Vehicles (Excise) Act 1962, or  (d) the 1971 Act  and,  in relation to the date on which a vehicle was registered, the date on which it was first registered under any of those enactments.
relevant braking requirement	a requirement that the brakes of a motor vehicle (as assisted, where a trailer is being drawn, by the brakes on the trailer) comply—  (i) in a case to which item 1 in Table 1 in regulation 18 applies, with the requirements specified in regulation 18(3) for vehicles falling in that item;  (ii) in any other case, with the requirements specified in regulation 18(3) for vehicle classes (a) and (b) in item 2 of that Table (whatever the date of first use of the motor vehicle and the date of manufacture of any trailer drawn by it may be).
resilient tyre	a tyre, not being a pneumatic tyre, which is of soft or elastic material, having regard to paragraph (5).
[ <sup>F32</sup> restricted speed vehicle	a vehicle displaying at its rear a “50” plate in accordance with the requirements of Schedule 13.
retreaded tyre	a tyre which has been reconditioned to extend its useful life by replacement of the tread rubber or by replacement of the tread rubber and renovation of the sidewall rubber.]
rigid vehicle	a motor vehicle which is not constructed or adapted to form part of an articulated vehicle or articulated bus.
[ <sup>F33</sup> rim diameter	is to be interpreted in accordance with the British Standard BS AU 50: Part 2: Section 1: 1980 entitled “British Standard Automobile Series: Specification for Tyres and Wheels Part 2. Wheels and rims Section 1. Rim profiles and dimensions (including openings for valves)” which came into effect on 28th November 1980.
rim diameter size code	is to be interpreted in accordance with the British Standard referred to in the meaning given in this Table to “rim diameter”.]
secondary braking system	a braking system of a vehicle applied by a secondary means of operation independent of the service braking system or by one of the sections comprised in a split braking system.
service braking system	the braking system of a vehicle which is designed and constructed to have the highest braking efficiency of any of the braking systems with which the vehicle is equipped.
semi-trailer	a trailer which is constructed or adapted to form part of an articulated vehicle [ <sup>F34</sup> including (without prejudice to the generality of that) a



**Status:** This revised version has been created from an electronic version contributed by Westlaw which was originally derived from the printed publication. **Read more** (See end of Document for details) **Changes to legislation:** There are currently no known outstanding effects for the The Road Vehicles (Construction and Use) Regulations 1986. (See end of Document for details)

<i>1</i> Expression	<i>2</i> Meaning
silencer	vehicle which is not itself a motor vehicle but which has some or all of its wheels driven by the drawing vehicle].
single-decked vehicle	a contrivance suitable and sufficient for reducing as far as may be reasonable the noise caused by the escape of exhaust gases from the engine of a motor vehicle.
split braking system	a vehicle upon which no part of a deck or gangway is vertically above another deck or gangway.
	in relation to a motor vehicle, a braking system so designed and constructed that—
	(a) it comprises two independent sections of mechanism capable of developing braking force such that, excluding the means of operation, a failure of any part (other than a fixed member or a brake shoe anchor pin) of one of the said sections will not cause a decrease in the braking force capable of being developed by the other section;
	(b) the said two sections are operated by a means of operation which is common to both sections;
	(c) the braking efficiency of either of the said two sections can be readily checked.
[ <sup>F4</sup> stepframe low loader	a semi-trailer (not being a low loader) which is constructed and normally used for the carriage of engineering equipment and is so constructed that the upper surface of the major part of the load platform is at a height of less than 1m above the ground when measured on level ground and when—
	(a) any adjustable suspension is at the normal travelling height,
	(b) all pneumatic tyres are suitably inflated for use when the vehicle is fully laden, and
	(c) the semi-trailer is unladen.]
stored energy	in relation to a braking system of a vehicle, energy (other than the muscular energy of the driver or the mechanical energy of a spring) stored in a reservoir for the purpose of applying the brakes under the control of the driver, either directly or as a supplement to his muscular energy.
straddle carrier	a motor vehicle constructed to straddle and lift its load for the purpose of transportation.
[ <sup>F6</sup> staircase	means a staircase by means of which passengers on a double-decked vehicle may pass to and from the upper deck of the vehicle;]
statutory power of removal	a power conferred by or under any enactment to remove or move a vehicle from any road or from any part of a road.
temporary use spare tyre	a pneumatic tyre which is designed for use on a motor vehicle only—
	(a) in the event of the failure of one of the tyres normally fitted to a wheel of the vehicle, and

**Status:** Point in time view as at 31/03/2009.

**Status:** This revised version has been created from an electronic version contributed by Westlaw which was originally derived from the printed publication. **Read more** (See end of Document for details)**Changes to legislation:** There are currently no known outstanding effects for the The Road Vehicles (Construction and Use) Regulations 1986. (See end of Document for details)

<i>1</i> Expression	<i>2</i> Meaning
	(b) at a speed lower than that for which such normally fitted tyres are designed.
three-wheeled motor cycle	a motor cycle having three wheels, not including a two-wheeled motor cycle with a sidecar attached.
towing implement	a device on wheels designed for the purpose of enabling a motor vehicle to draw another vehicle by the attachment of that device to that other vehicle in such a manner that part of that other vehicle is secured to and either rests on or is suspended from the device and some but not all of the wheels on which that other vehicle normally runs are raised off the ground.
track-laying	in relation to a vehicle, so designed and constructed that the weight thereof is transmitted to the road surface either by means of continuous tracks or by a combination of wheels and continuous tracks in such circumstances that the weight transmitted to the road surface by the tracks is not less than half the weight of the vehicle.
trailer	means a vehicle drawn by a motor vehicle and is to be interpreted in accordance with paragraphs (9) and (11).
train weight	in relation to a motor vehicle which may draw a trailer, the maximum laden weight for the motor vehicle together with any trailer which may be drawn by it.
transverse plane	a vertical plane at right angles to the longitudinal axis of a vehicle.
trolley bus	a bus adapted for use on roads without rails and moved by power transmitted thereto from some external source.
unbraked trailer	any trailer other than one which, whether or not regulation 15 or 16 applies to it, is equipped with a braking system in accordance with one of those regulations.
unladen weight	the weight of a vehicle or trailer inclusive of the body and all parts (the heavier being taken where alternative bodies or parts are used) which are necessary to or ordinarily used with the vehicle or trailer when working on a road, but exclusive of the weight of water, fuel or accumulators used for the purpose of the supply of power for the propulsion of the vehicle or, as the case may be, of any vehicle by which the trailer is drawn, and of loose tools and loose equipment.
vehicle in the service of a visiting force or of a headquarters	a vehicle so described in Article 8(6) of the Visiting Forces and International Headquarters (Application of Law) Order 1965
wheel	a wheel the tyre or rim of which when the vehicle is in motion on a road is in contact with the ground; two wheels are to be regarded as one wheel in the circumstances specified in paragraph (7).
wheeled	in relation to a vehicle, so constructed that the whole weight of the vehicle is transmitted to the road surface by means of wheels.
Wide tyre	a pneumatic tyre of which the area of contact with the road surface is not less than 300mm in width when measured at right angles to the longitudinal axis of the vehicle.

**Status:** This revised version has been created from an electronic version contributed by Westlaw which was originally derived from the printed publication. **Read more** (See end of Document for details)**Changes to legislation:** There are currently no known outstanding effects for the The Road Vehicles (Construction and Use) Regulations 1986. (See end of Document for details)

<i>1</i> Expression	<i>2</i> Meaning
works trailer	a trailer designed for use in private premises and used on a road only in delivering goods from or to such premises to or from a vehicle on a road in the immediate neighbourhood, or in passing from one part of any such premises to another or to other private premises in the immediate neighbourhood or in connection with road works while at or in the immediate neighbourhood of the site of such works.
works truck	a motor vehicle (other than a straddle carrier) designed for use in private premises and used on a road only in delivering goods from or to such premises to or from a vehicle on a road in the immediate neighbourhood, or in passing from one part of any such premises to another or to other private premises in the immediate neighbourhood or in connection with road works while at or in the immediate neighbourhood of the site of such works.

[<sup>F35</sup>(2A) Without prejudice to section 17 of the Interpretation Act 1978(3) and subject to the context, a reference in these Regulations to any enactment comprised in subordinate legislation (within the meaning of that Act) is a reference to that enactment as from time to time amended or re-enacted with or without modification.]

- (3) For the purpose of these Regulations, the date on which a motor vehicle is first used is—
- (a) in the case of a vehicle not falling within sub-paragraph (b) and which is registered, the date on which it was registered;
  - (b) in each of the following cases—
    - (i) a vehicle which is being or has been used under a trade licence as defined in section 16 of the 1971 Act (otherwise than for the purposes of demonstration or testing or of being delivered from premises of the manufacturer by whom it was made or of a distributor of vehicles, or dealer in vehicles, to premises of a distributor of vehicles, dealer in vehicles or purchaser thereof or to premises of a person obtaining possession thereof under a hiring agreement or hire purchase agreement);
    - (ii) a vehicle belonging, or which has belonged, to the Crown and which is or was used or appropriated for use for naval, military or air force purposes;
    - (iii) a vehicle belonging, or which has belonged, to a visiting force or a headquarters or defence organisation to which in each case the Visiting Forces and International Headquarters (Application of Law) Order 1965 applies;
    - (iv) a vehicle which has been used on roads outside Great Britain before being imported into Great Britain; and
    - (v) a vehicle which has been used otherwise than on roads after being sold or supplied by retail and before being registered;

the date of manufacture of the vehicle.

In sub-paragraph (b) (v) of this paragraph “sold or supplied by retail” means sold or supplied otherwise than to a person acquiring it solely for the purpose of resale or re-supply for a valuable consideration .

(4) The date of manufacture of a vehicle to which the Type Approval for Goods Vehicles Regulations apply shall be the date of manufacture described in regulation 2(4)(a) of those Regulations.

(3) The amending instruments are S.I. 1983/239 and 1800, 1984/178, 816 and 1024 and 1985/44.

**Status:** Point in time view as at 31/03/2009.

**Status:** This revised version has been created from an electronic version contributed by Westlaw which was originally derived from the printed publication. **Read more** (See end of Document for details)**Changes to legislation:** There are currently no known outstanding effects for the The Road Vehicles (Construction and Use) Regulations 1986. (See end of Document for details)

(5) Save where otherwise provided in these Regulations a tyre shall not be deemed to be of soft or elastic material unless the said material is either—

- (a) continuous round the circumference of the wheel; or
- (b) fitted in sections so that so far as reasonably practicable no space is left between the ends thereof,

and is of such thickness and design as to minimise, so far as reasonably possible, vibration when the vehicle is in motion and so constructed as to be free from any defect which might in any way cause damage to the surface of a road.

(6) For the purpose of these Regulations a brake drum and a brake disc shall be deemed to form part of the wheel and not of the braking system.

(7) For the purpose of these Regulations other than regulations 26 and 27 any two wheels of a motor vehicle or trailer shall be regarded as one wheel if the distance between the centres of the areas of contact between such wheels and the road surface is less than 460 mm.

(8) For the purpose of these Regulations other than regulations 26 and 27 in counting the number of axles of, and in determining the sum of the weights transmitted to the road surface by any one axle of, a vehicle, all the wheels of which the centres of the areas of contact with the road surface can be included between any two transverse planes less than [<sup>F36</sup>0.5] m apart shall be treated as constituting one axle.

[<sup>F37</sup>(8A) For the purposes of these Regulations, a reference to axles being closely-spaced is a reference to—

- (a) two axles (not being part of a group of axles falling within sub-paragraph (b) or (c)) which are spaced at a distance apart of not more than 2.5m;
- (b) three axles (not being part of a group of axles falling within sub-paragraph (c)) the outermost of which are spaced at a distance apart of not more than 3.25m; or
- (c) four or more axles the outermost of which are spaced at a distance apart of not more than 4.6m;

the number of axles for the purposes of these paragraphs being determined in accordance with paragraph (8); and a reference to any particular number of closely-spaced axles shall be construed accordingly.]

(9) The provisions of these Regulations relating to trailers do not apply to any part of an articulated bus.

(10) For the purpose of [<sup>F38</sup>paragraph (8A) above,] regulations 51, [<sup>F39</sup>76, 77 and 79] and [<sup>F40</sup>Schedules 11 and 11A]<sup>F41</sup> ..., the distance between any two axles shall be obtained by measuring the shortest distance between the line joining the centres of the areas of contact with the road surface of the wheels of one axle and the line joining the centres of the areas of contact with the road surface of the wheels of the other axle.

(11) For the purpose of the following provisions only, a composite trailer shall be treated as one trailer (not being a semi-trailer or a converter dolly)—

- (a) regulations 7, 76 and 83;
- (b) paragraph (2) of, and items 3 and 10 in the Table in, regulation 75;
- (c) item 2 in the Table in regulation 78.

**Status:** This revised version has been created from an electronic version contributed by Westlaw which was originally derived from the printed publication. **Read more** (See end of Document for details)**Changes to legislation:** There are currently no known outstanding effects for the The Road Vehicles (Construction and Use) Regulations 1986. (See end of Document for details)

### Textual Amendments

- F1** Words in reg. 3(2) Table inserted (20.10.2006) by The Road Vehicles (Construction and Use) and Motor Vehicles (Type Approval for Goods Vehicles) (Great Britain) (Amendment) Regulations 2006 (S.I. 2006/2565), regs. 1(2), **3**
- F2** Words in reg. 3(2) Table inserted (1.10.1996) by The Road Vehicles (Construction and Use) (Amendment) (No. 5) Regulations 1996 (S.I. 1996/2329), regs. 1, **3(a)**
- F3** Words in reg. 3(2) Table added (1.5.2002) by The Road Vehicles (Construction and Use) (Amendment) (No. 4) Regulations 2001 (S.I. 2001/3208), regs. 1(2), **3(2)**
- F4** Words in reg. 3(2) Table inserted (19.3.1990) by The Road Vehicles (Construction and Use) (Amendment) Regulations 1990 (S.I. 1990/317), regs. 1, **3(1)**
- F5** Words in reg. 3(2) Table omitted (1.1.1993) by virtue of The Road Vehicles (Construction and Use) (Amendment) (No. 4) Regulations 1992 (S.I. 1992/2016), regs. 1, **3(2)**
- F6** Words in reg. 3(2) Table inserted (31.7.1987) by The Road Vehicles (Construction and Use) (Amendment) (No.2) Regulations 1987 (S.I. 1987/1133), regs. 1, **3**
- F7** Words in reg. 3(2) added (12.12.2005) by The Road Vehicles (Construction and Use) (Amendment) (No. 4) Regulations 2005 (S.I. 2005/3165), regs. 1, **3**
- F8** Words in reg. 3(2) Table substituted (8.11.1989) by The Road Vehicles (Construction and Use) (Amendment) (No. 3) Regulations 1989 (S.I. 1989/1865), regs. 1, **3(a)**
- F9** Words in reg. 3(2) Table substituted (8.11.1989) by The Road Vehicles (Construction and Use) (Amendment) (No. 3) Regulations 1989 (S.I. 1989/1865), regs. 1, **3(b)**
- F10** Words in reg. 3(2) Table inserted (24.3.1994) by The Road Vehicles (Construction and Use) (Amendment) (No. 2) Regulations 1994 (S.I. 1994/329), regs. 1, **3(2)(c)**
- F11** Words in reg. 3(2) Table substituted (1.11.1991) by The Road Vehicles (Construction and Use) (Amendment) (No. 1) Regulations 1991 (S.I. 1991/1526), regs. 1, **3**
- F12** Words in reg. 3(2) Table inserted (1.10.1996) by The Road Vehicles (Construction and Use) (Amendment) (No. 5) Regulations 1996 (S.I. 1996/2329), regs. 1, **3(b)**
- F13** Words in reg. 3(2) Table substituted (1.5.2002) by The Road Vehicles (Construction and Use) (Amendment) (No. 4) Regulations 2001 (S.I. 2001/3208), regs. 1(2), **3(3)**
- F14** Words in reg. 3(2) Table inserted (2.11.1990) by The Road Vehicles (Construction and Use) (Amendment) (No. 4) Regulations 1990 (S.I. 1990/1981), regs. 1, **3(a)** (with reg. 2(2))
- F15** Words in reg. 3(2) Table inserted (2.11.1990) by The Road Vehicles (Construction and Use) (Amendment) (No. 4) Regulations 1990 (S.I. 1990/1981), regs. 1, **3(b)** (with reg. 2(2))
- F16** Words in reg. 3(2) Table inserted (2.11.1990) by The Road Vehicles (Construction and Use) (Amendment) (No. 4) Regulations 1990 (S.I. 1990/1981), regs. 1, **3(c)** (with reg. 2(2))
- F17** Words in reg. 3(2) Table substituted (24.3.1994) by The Road Vehicles (Construction and Use) (Amendment) (No. 2) Regulations 1994 (S.I. 1994/329), regs. 1, **3(2)(a)**
- F18** Words in reg. 3(2) Table inserted (2.11.1990) by The Road Vehicles (Construction and Use) (Amendment) (No. 4) Regulations 1990 (S.I. 1990/1981), regs. 1, **3(d)** (with reg. 2(2))
- F19** Words in reg. 3(2) Table inserted (2.11.1990) by The Road Vehicles (Construction and Use) (Amendment) (No. 4) Regulations 1990 (S.I. 1990/1981), regs. 1, **3(e)** (with reg. 2(2))
- F20** Words in reg. 3(2) Table substituted (1.1.1999) by The Road Vehicles (Construction and Use) (Amendment) (No. 7) Regulations 1998 (S.I. 1998/3112), regs. 1, **3**
- F21** Words in reg. 3(2) Table inserted (26.6.1990) by The Road Vehicles (Construction and Use) (Amendment) (No. 2) Regulations 1990 (S.I. 1990/1131), regs. 1, **3** (with reg. 2(2))
- F22** Words in reg. 3 Table omitted (1.4.2003) by The Road Vehicles (Construction and Use) (Amendment) Regulations 2003 (S.I. 2003/182), regs. 1, **2**
- F23** Word in reg. 3(2) Table omitted (17.10.1991) by virtue of The Road Vehicles (Construction and Use) (Amendment) (No. 4) Regulations 1991 (S.I. 1991/2125), regs. 1, **3(2)**
- F24** Words in reg. 3(2) Table added (17.10.1991) by The Road Vehicles (Construction and Use) (Amendment) (No. 4) Regulations 1991 (S.I. 1991/2125), regs. 1, **3(2)**

**Status:** Point in time view as at 31/03/2009.

**Status:** This revised version has been created from an electronic version contributed by Westlaw which was originally derived from the printed publication. **Read more** (See end of Document for details)**Changes to legislation:** There are currently no known outstanding effects for the The Road Vehicles (Construction and Use) Regulations 1986. (See end of Document for details)

- F25** Words in reg. 3(2) Table substituted (1.6.1998) by The Road Vehicles (Construction and Use) (Amendment) (No. 3) Regulations 1998 (S.I. 1998/1188), regs. 1, **3**
- F26** Word in reg. 3(2) Table omitted (1.1.1996) by virtue of The Road Vehicles (Construction and Use) (Amendment) (No. 6) Regulations 1995 (S.I. 1995/3051), regs. 1, **3(a)**
- F27** Words in reg. 3(2) Table inserted (1.1.1996) by The Road Vehicles (Construction and Use) (Amendment) (No. 6) Regulations 1995 (S.I. 1995/3051), regs. 1, **3(b)**
- F28** Words in reg. 3(2) Table substituted (2.11.1990) by The Road Vehicles (Construction and Use) (Amendment) (No. 4) Regulations 1990 (S.I. 1990/1981), regs. 1, **3(f)** (with reg. 2(2))
- F29** Words in reg. 3 substituted (17.9.2003) by The Communications Act 2003 (Consequential Amendments) Order 2003 (S.I. 2003/2155), art. 1(1), **Sch. 1 para. 27(2)**
- F30** Words in reg. 3(2) Table substituted (26.3.2001) by The Postal Services Act 2000 (Consequential Modifications No. 1) Order 2001 (S.I. 2001/1149), art. 1(2), **Sch. 1 para. 69**
- F31** Words in reg. 3(2) Table substituted (1.3.1996) by The Gas Act 1995 (Consequential Modifications of Subordinate Legislation) Order 1996 (S.I. 1996/252), art. 1, **Sch.**
- F32** Words in reg. 3(2) Table inserted (2.11.1990) by The Road Vehicles (Construction and Use) (Amendment) (No. 4) Regulations 1990 (S.I. 1990/1981), regs. 1, **3(g)** (with reg. 2(2))
- F33** Words in reg. 3(2) Table inserted (2.11.1990) by The Road Vehicles (Construction and Use) (Amendment) (No. 4) Regulations 1990 (S.I. 1990/1981), regs. 1, **3(h)** (with reg. 2(2))
- F34** Words in reg. 3(2) Table added (6.5.1987) by The Road Vehicles (Construction and Use) (Amendment) Regulations 1987 (S.I. 1987/676), regs. 1(2), **5**
- F35** Reg. 3(2A) inserted (1.10.1993) by The Road Vehicles (Construction and Use) (Amendment) (No. 2) Regulations 1993 (S.I. 1993/2199), regs. 1, **3**
- F36** Word in reg. 3(8) substituted (1.1.1993) by The Road Vehicles (Construction and Use) (Amendment) (No. 4) Regulations 1992 (S.I. 1992/2016), regs. 1, **3(3)**
- F37** Reg. 3(8A) inserted (1.1.1993) by The Road Vehicles (Construction and Use) (Amendment) (No. 4) Regulations 1992 (S.I. 1992/2016), regs. 1, **3(4)**
- F38** Words in reg. 3(10) inserted (1.1.1993) by The Road Vehicles (Construction and Use) (Amendment) (No. 4) Regulations 1992 (S.I. 1992/2016), regs. 1, **3(5)**
- F39** Words in reg. 3(10) substituted (1.1.1989) by The Road Vehicles (Construction and Use) (Amendment) (No.5) Regulations 1988 (S.I. 1988/1287), regs. 1, **3** (with reg. 2(2))
- F40** Words in reg. 3(10) substituted (24.3.1994) by The Road Vehicles (Construction and Use) (Amendment) (No. 2) Regulations 1994 (S.I. 1994/329), regs. 1, **3(3)**
- F41** Words in reg. 3(10) omitted (1.1.1993) by virtue of The Road Vehicles (Construction and Use) (Amendment) (No. 4) Regulations 1992 (S.I. 1992/2016), regs. 1, **3(5)**

#### Modifications etc. (not altering text)

- C1** Reg. 3(7)(8) applied (1.7.1997) by The Motor Vehicles (Approval) Regulations 1996 (S.I. 1996/3013), regs. 1, **2(3)**
- C2** Reg. 3(7)(8) applied (1.2.2001) by The Motor Vehicles (Approval) Regulations 2001 (S.I. 2001/25), regs. 1, **3(4)**
- C3** Reg. 3(7)(8) applied (8.8.2003) by The Motor Cycles Etc. (Single Vehicle Approval) Regulations 2003 (S.I. 2003/1959), regs. 1, **2(5)**

#### Commencement Information

- I3** Reg. 3 in force at 11.8.1986, see **reg. 1**

#### [<sup>F42</sup>Modification of Regulations in relation to vehicles for which a Minister's approval certificate has been issued under the Motor Vehicles (Approval) Regulations 1996

**3A.** Schedule 2A shall have effect for the purpose of modifying these Regulations in relation to vehicles in respect of which a Minister's approval certificate has been issued by virtue of the Motor Vehicles (Approval) Regulations 1996.]

**Status:** This revised version has been created from an electronic version contributed by Westlaw which was originally derived from the printed publication. **Read more** (See end of Document for details)**Changes to legislation:** There are currently no known outstanding effects for the The Road Vehicles (Construction and Use) Regulations 1986. (See end of Document for details)

### Textual Amendments

**F42** Reg. 3A inserted (1.7.1997) by The Road Vehicles (Construction And Use) (Amendment) (No. 6) Regulations 1996 (S.I. 1996/3017), regs. 1, 3

### Application and Exemptions

4.—(1) Save where the context otherwise requires, these Regulations apply to both wheeled vehicles and track-laying vehicles.

(2) Where a provision is applied by these Regulations to a motor vehicle first used on or after a specified date it does not apply to that vehicle if it was manufactured at least six months before that date.

(3) Where an exemption from, or relaxation of, a provision is applied by these Regulations to a motor vehicle first used before a specified date it shall also apply to a motor vehicle first used on or after that date if it was manufactured at least six months before that date.

(4) [<sup>F43</sup>Subject to paragraph (7),] the regulations specified in an item in column 3 of the Table do not apply in respect of a vehicle of a class specified in that item in column 2.

### TABLE

(regulation 4(4))

<i>1</i> Item	<i>2</i> Class of Vehicle	<i>3</i> Regulations which do not apply
1	A vehicle proceeding to a port for export.	The regulations in Part II insofar as they relate to construction and equipment, except regulations 16 (insofar as it concerns parking brakes) 20, 30, 34, 37 and 53.  Regulations 66 to 69 and 71.
2	A vehicle brought temporarily into Great Britain by a person resident abroad, provided that the vehicle complies in every respect with the requirements relating to motor vehicles or trailers contained in—  (a) article 21 and paragraph (1) of article 22 of the Convention on Road Traffic concluded at Geneva on 19th September 1949 <sup>(12)</sup> and [ <sup>F44</sup> Part I,] Part II (so far as it relates to direction indicators and stop lights) and Part III of Annex 6 to that Convention; or  (b) paragraphs I, III and VIII of article 3 of the International Convention relative	The regulations in Part II insofar as they relate to construction and equipment except regulations 7, 8, <sup>F45</sup> ... 10, [ <sup>F46</sup> 10A,] 40 [ <sup>F47</sup> and 53][ <sup>F48</sup> , and (a) additionally, in respect of any passenger vehicle with a maximum gross weight exceeding 10 tonnes registered in one or more member States, regulations 36A(2), 36A(7) and 36A(9); (b) additionally, in respect of any goods vehicle with a maximum gross weight exceeding 12 tonnes registered in one or more member States, regulations 36(B)(2), 36B(9) and 36B(11)].

*Status:* Point in time view as at 31/03/2009.

*Status:* This revised version has been created from an electronic version contributed by Westlaw which was originally derived from the printed publication. **Read more** (See end of Document for details)**Changes to legislation:** There are currently no known outstanding effects for the The Road Vehicles (Construction and Use) Regulations 1986. (See end of Document for details)

1 Item	2 Class of Vehicle	3 Regulations which do not apply
	to Motor Traffic concluded at Paris on 24th April 1926 (13)	Regulations 66 to 69 and 71.
3	A vehicle manufactured in Great Britain which complies with the requirements referred to in item 2 above and contained in the Convention of 1949, or, as the case may be, 1926 referred to in that item as if the vehicle had been brought temporarily into Great Britain, and either—  (a) is exempt from car tax by virtue of [F49]section 7(1), (2) and (3) of the Car Tax Act 1983], or  (b) has been zero rated under [F50]regulation 56 or 57 of the Value Added Tax (General) Regulations 1985].	The regulations in Part II insofar as they relate to construction and equipment, except regulations 7, 8, F45... 10, [F5110A,] 40 [F52and 53].  Regulations 66 to 69 and 71.
4	A vehicle in the service of a visiting force or of a headquarters.	The regulations in Part II insofar as they relate to construction and equipment, except regulations F45... 16 (insofar as it concerns parking brakes), 21, 53 F53... and 61.  Regulations 66 to 69, [F5471, 75 to 79 and 93A].
5	A vehicle which has been submitted for an examination under section 43 or [F55]section 45] of the 1972 Act while it is being used on a road in connection with the carrying out of that examination and is being so used by a person who is empowered under that section to carry out that examination, or by a person acting under the direction of a person so empowered.	The regulations in Part II F56 ... Regulations 75 to 79 and 100.
6	A motor car or a motor cycle in respect of which a certificate has been issued by the Officer in Charge of the National Collections of Road Transport, the Science Museum, London SW7. that it was designed before 1st January 1905 and constructed before 31st December 1905.	Regulations 16 (except insofar as it applies requirements 3 and 6 in Schedule 3), 21, 37(4), 63 and 99(4).



*Status: This revised version has been created from an electronic version contributed by Westlaw which was originally derived from the printed publication. Read more (See end of Document for details) Changes to legislation: There are currently no known outstanding effects for the The Road Vehicles (Construction and Use) Regulations 1986. (See end of Document for details)*

<i>1</i>	<i>2</i>	<i>3</i>
<i>Item</i>	<i>Class of Vehicle</i>	<i>Regulations which do not apply</i>
7	(a) A towing implement which is being drawn by a motor vehicle while it is not attached to any vehicle except the one drawing it if — (i) the towing implement is not being so drawn during the hours of darkness, and (ii) the vehicle by which it is being so drawn is not driven at a speed exceeding 20 mph; or (b) a vehicle which is being drawn by a motor vehicle in the exercise of a statutory power of removal.	The regulations in Part II insofar as they relate to the construction and equipment of trailers, except regulation 20.
[ <sup>F578</sup>	Tramcars	The regulations in Parts II, III and IV]
[ <sup>F589</sup>	A public works vehicle which has a maximum design weight of 7500kg and is specifically designed for use and used solely for the purpose of street cleansing.	Regulation 15(1E) and (5B) in respect of the requirements in Community Directive 98/12/EC and ECE Regulation 13.09 which require the fitting of ABS to goods vehicles over 3500kg in weight.]
[ <sup>F58</sup> 10	A vehicle being used by a Police Authority which has been authorised by a Chief Constable to perform accident reconstruction duties.	Regulation 15(1E) and (5B) in respect of the requirements in Community Directive 98/12/EC and ECE Regulation 13.09 which prohibit the use of an isolation switch for the operation of ABS.]
[ <sup>F59</sup> 11	A vehicle being used on a road by a vehicle examiner, who has been authorised in writing by the Secretary of State for the purpose of— (a) submitting the vehicle for an examination under section 45 of the Road Traffic Act 1988 in order to ascertain whether the examination is carried out in accordance with regulations made under that section; or (b) removing the vehicle following that examination.	The regulations in Part 2. Regulations 67, 75 to 79 and 100.]

(5) Any reference to a broken down vehicle shall include a reference to any towing implement which is being used for the drawing of any such vehicle.

(6) The Secretary of State is satisfied that it is requisite that the provisions of regulation 40(2) should apply, as from the date on which these Regulations come into operation, to track-laying vehicles registered before the expiration of one year from the making of these Regulations; and

**Status:** Point in time view as at 31/03/2009.

**Status:** This revised version has been created from an electronic version contributed by Westlaw which was originally derived from the printed publication. **Read more** (See end of Document for details)**Changes to legislation:** There are currently no known outstanding effects for the The Road Vehicles (Construction and Use) Regulations 1986. (See end of Document for details)

that, notwithstanding that those provisions will then apply to these vehicles, no undue hardship or inconvenience will be caused thereby.

[<sup>F60</sup>(7) The exemption provided by item 11 in the Table in paragraph (4) shall only apply to the extent that the vehicle examiner using the vehicle in question reasonably believes that any defects in that vehicle do not give rise to a danger of injury to any person while it is being used by that person for a purpose mentioned in that item.

(8) In item 11 in the Table in paragraph (4) and paragraph (7), “vehicle examiner” means an examiner appointed under section 66A of the Road Traffic Act 1988.]

### Textual Amendments

- F43** Words in reg. 4(4) inserted (12.12.2005) by The Road Vehicles (Construction and Use)(Amendment) (No. 4) Regulations 2005 (S.I. 2005/3165), regs. 1, **4(2)(a)**
- F44** Words in reg. 4(4) Table inserted (18.3.1988) by The Road Vehicles (Construction and Use) (Amendment) Regulations 1988 (S.I. 1988/271), regs. 1, **3(a)**
- F45** Word in reg. 4(4) Table omitted (1.6.1995) by virtue of The Road Vehicles (Construction and Use) (Amendment) (No. 3) Regulations 1995 (S.I. 1995/1201), regs. 1, **5(1)**
- F46** Word in reg. 4 Table Item 2 inserted (1.10.1997) by The Road Vehicles (Construction and Use) (Amendment) Regulations 1997 (S.I. 1997/530), regs. 1(1), **3(2)**
- F47** Words in reg. 4(4) Table Item 2 substituted (1.7.1994) by The Road Vehicles (Construction and Use) (Amendment) Regulations 1994 (S.I. 1994/14), regs. 1(1), **3(1)(a)**
- F48** Words in reg. 4(4) Table inserted (1.9.2003) by The Road Vehicles (Construction and Use) (Amendment) (No. 3) Regulations 2003 (S.I. 2003/1946), regs. 1, **3(2)**
- F49** Words in reg. 4(4) Table substituted (18.3.1988) by The Road Vehicles (Construction and Use) (Amendment) Regulations 1988 (S.I. 1988/271), regs. 1, **3(b)**
- F50** Words in reg. 4(4) Table substituted (18.3.1988) by The Road Vehicles (Construction and Use) (Amendment) Regulations 1988 (S.I. 1988/271), regs. 1, **3(c)**
- F51** Word in reg. 4 Table Item 3 inserted (1.10.1997) by The Road Vehicles (Construction and Use) (Amendment) Regulations 1997 (S.I. 1997/530), regs. 1(1), **3(2)**
- F52** Words in reg. 4(4) Table Item 3 substituted (1.7.1994) by The Road Vehicles (Construction and Use) (Amendment) Regulations 1994 (S.I. 1994/14), regs. 1(1), **3(1)(a)**
- F53** Words in reg. 4(4) Table Item 4 omitted (1.7.1994) by virtue of The Road Vehicles (Construction and Use) (Amendment) Regulations 1994 (S.I. 1994/14), regs. 1(1), **3(1)(b)**
- F54** Words in reg. 4 Table Item 4 substituted (3.1.1997) by The Road Vehicles (Construction and Use) (Amendment) (No. 8) Regulations 1996 (S.I. 1996/3133), regs. 1, **3**
- F55** Words in reg. 4(4) Table substituted (18.3.1988) by The Road Vehicles (Construction and Use) (Amendment) Regulations 1988 (S.I. 1988/271), regs. 1, **3(d)**
- F56** Words in reg. 4(4) Table Item 5 omitted (1.7.1994) by virtue of The Road Vehicles (Construction and Use) (Amendment) Regulations 1994 (S.I. 1994/14), regs. 1(1), **3(1)(c)**
- F57** Reg. 4 Table Item 8 added (1.7.1992) by Tramcars and Trolley Vehicles (Modification of Enactments) Regulations 1992 (S.I. 1992/1217), regs. 1, **13**
- F58** Reg. 4 Table Items 9, 10 inserted (1.5.2002) by The Road Vehicles (Construction and Use) (Amendment) (No. 4) Regulations 2001 (S.I. 2001/3208), regs. 1(2), **4(1)**
- F59** Reg. 4(4) Table Item 11 inserted (12.12.2005) by The Road Vehicles (Construction and Use) (Amendment)(No. 4) Regulations 2005 (S.I. 2005/3165), regs. 1, **4(2)(b)**
- F60** Reg. 4(7)(8) inserted (12.12.2005) by The Road Vehicles (Construction and Use)(Amendment)(No. 4) Regulations 2005 (S.I. 2005/3165), regs. 1, **4(3)**

### Commencement Information

- I4** Reg. 4 in force at 11.8.1986, see **reg. 1**

## Trade Descriptions Act 1968

<sup>F61</sup>5. ....

### Textual Amendments

**F61** Reg. 5 revoked (26.5.2008) by [The Consumer Protection from Unfair Trading Regulations 2008 \(S.I. 2008/1277\)](#), reg. 1, Sch. 2 para. 78, **Sch. 4 Pt. 2** (with reg. 28(2)(3))

## Compliance with Community Directives and ECE Regulations

6.—(1) For the purpose of any regulation which requires or permits a vehicle to comply with the requirements of a Community Directive or an ECE Regulation, a vehicle shall be deemed so to have complied at the date of its first use only if—

- (a) one of the certificates referred to in paragraph (2) has been issued in relation to it; or
- (b) the marking referred to in paragraph (3) has been applied; or
- (c) it was, before it was used on a road, subject to a relevant type approval requirement as specified in paragraph (4).

(2) The certificates mentioned in paragraph (1) are—

- (b) a certificate of conformity issued by the manufacturer of the vehicle under regulation 6 of either of those Regulations; <sup>F62</sup>...
- (c) a certificate issued under a provision of the law of any member state of the European Economic Community which corresponds to the said regulations 5 or 6 <sup>F63</sup>; or
- (d) a sound level measurement certificate issued by the Secretary of State under regulation 4 of the Motorcycles (Sound Level Measurement Certificates) Regulations 1980;]

being in each case a certificate issued by reason of the vehicle's conforming to the requirements of the Community Directive in question.

- (a) a type approval certificate issued by the Secretary of State under regulation 5 of the Type Approval Regulations or of the Type Approval for Agricultural Vehicles Regulations;

(3) The marking mentioned in paragraph (1) is a marking designated as an approval mark by regulation 4 of the Approval Marks Regulations, being in each case a mark shown in column 2 of an item in Schedule 2 to those Regulations which refers, in column 5, to the ECE Regulation in question, applied as indicated in column 4 in that item.

(4) A relevant type approval requirement is a requirement of the Type Approval (Great Britain) Regulations or the Type Approval for Goods Vehicles Regulations which appears—

- (a) in column 4 of Table I in Schedule 2 in the item in which the Community Directive in question appears in column 3, or
- (b) in column 4 of Table II in Schedule 2 in the item in which the ECE Regulation in question appears in column 3.

### Textual Amendments

**F62** Word in reg. 6(2)(b) omitted (8.11.1989) by virtue of [The Road Vehicles \(Construction and Use\) \(Amendment\) \(No. 3\) Regulations 1989 \(S.I. 1989/1865\)](#), regs. 1, 4 (with reg. 2(2))

**F63** Reg. 6(2)(d) and word inserted (8.11.1989) by [The Road Vehicles \(Construction and Use\) \(Amendment\) \(No. 3\) Regulations 1989 \(S.I. 1989/1865\)](#), regs. 1, 4 (with reg. 2(2))

**Status:** Point in time view as at 31/03/2009.

**Status:** This revised version has been created from an electronic version contributed by Westlaw which was originally derived from the printed publication. **Read more** (See end of Document for details)**Changes to legislation:** There are currently no known outstanding effects for the The Road Vehicles (Construction and Use) Regulations 1986. (See end of Document for details)

### Commencement Information

**I5** Reg. 6 in force at 11.8.1986, see [reg. 1](#)

## PART II

### REGULATIONS GOVERNING THE CONSTRUCTION, EQUIPMENT AND MAINTENANCE OF VEHICLES

#### A

#### DIMENSIONS AND MANOEUVRABILITY

#### Length

7.—(1) Subject to paragraphs (2) to (6), the overall length of a vehicle or combination of vehicles of a class specified in an item in column 2 of the Table shall not exceed the maximum length specified in that item in column 3 of the Table, the overall length in the case of a combination of vehicles being calculated in accordance with regulation 81(g) and (h).

**TABLE**

(regulation 7(1))

1	2	3
<i>Item</i>	<i>Class of vehicle</i>	<i>Maximum length (metres)</i>
	<i>Vehicle Combinations</i>	
[ <sup>F64</sup> 1	A motor vehicle (other than a motor vehicle such as is mentioned in item 1A) drawing one trailer which is not a semi-trailer.	18.75
1A	Subject to paragraph (3C), a motor vehicle manufactured before 1st June 1998 and drawing one trailer, where the combination does not meet the requirements of paragraph (5A) and the trailer is not a semi-trailer.	18]
2	An articulated bus.	[ <sup>F65</sup> 18.75]
[ <sup>F66</sup> 2A	A bus drawing a trailer	18.75]
3	An articulated vehicle [ <sup>F67</sup> the semi-trailer of which does not meet the requirements of [ <sup>F68</sup> para-graph (6)] paragraph (6) and is not a low loader.]	15.5
	<i>Motor vehicles</i>	
[ <sup>F69</sup> 3A	An articulated vehicle, the semi-trailer of which meets the requirements of paragraph (6) and is not a low loader.	16.5]
[ <sup>F69</sup> 3B	An articulated vehicle, the semi-trailer of which is a low loader.	18]
4	A wheeled motor vehicle [ <sup>F70</sup> other than a bus].	12

**Status:** This revised version has been created from an electronic version contributed by Westlaw which was originally derived from the printed publication. **Read more** (See end of Document for details)**Changes to legislation:** There are currently no known outstanding effects for the The Road Vehicles (Construction and Use) Regulations 1986. (See end of Document for details)

1	2	3
<i>Item</i>	<i>Class of vehicle</i>	<i>Maximum length (metres)</i>
[ <sup>F71</sup> 4A	A bus with two axles	13.5]
[ <sup>F72</sup> 4B	A bus with more than two axles	15]
5	A track-laying motor vehicle.	9.2
	<i>Trailers</i>	
6	An agricultural trailed appliance manufactured on or after 1st December 1985.	15
7	A semi-trailer manufactured on or after 1st May 1983 [ <sup>F73</sup> which does not meet the requirements of paragraph (6) and is not a low loader].	12.2
[ <sup>F74</sup> 7A	A composite trailer drawn by—	
	(a) a goods vehicle being a motor vehicle having a maximum gross weight exceeding 3500 kg; or	
	(b) an agricultural motor vehicle	14.04]
8	A trailer [ <sup>F75</sup> (not being a semi-trailer or composite trailer)] with at least 4 wheels which is—	
	(a) drawn by a goods vehicle being a motor vehicle having a maximum gross weight exceeding 3500 kg; or	
	(b) an agricultural trailer.	12
9	Any other trailer not being an agricultural trailed appliance or a semi-trailer.	7

(2) In the case of a motor vehicle drawing one trailer where—

- (a) the motor vehicle is a showman's vehicle as defined in paragraph 7 of Schedule 3 to the 1971 Act; and
- (b) the trailer is used primarily as living accommodation by one or more persons and is not also used for the carriage of goods or burden which are not needed for the purpose of such residence in the vehicle,

item 1 in the Table applies with the substitution of 22 m for 18 m [<sup>F76</sup>and item 1A in the Table does not apply].

[<sup>F77</sup>(3) Items 1 [<sup>F78</sup>, 1A], 3, 3A and 3B of the Table do not apply to—

- (a) a vehicle combination which includes a trailer which is constructed and normally used for the conveyance of indivisible loads of exceptional length, or
- (b) a vehicle combination consisting of a broken down vehicle (including an articulated vehicle) being drawn by a motor vehicle in consequence of a breakdown, [<sup>F79</sup>or
- (c) an articulated vehicle, the semi-trailer of which is a low loader manufactured before 1st April 1991.]

**Status:** Point in time view as at 31/03/2009.

**Status:** This revised version has been created from an electronic version contributed by Westlaw which was originally derived from the printed publication. **Read more** (See end of Document for details)**Changes to legislation:** There are currently no known outstanding effects for the The Road Vehicles (Construction and Use) Regulations 1986. (See end of Document for details)

(3A) Items 6, 7, 7A, 8 and 9 of the Table do not apply to—

- (a) a trailer which is constructed and normally used for the conveyance of indivisible loads of exceptional length,
- (b) a broken down vehicle (including an articulated vehicle) which is being drawn by a motor vehicle in consequence of a breakdown, or
- (c) a trailer being a drying or mixing plant designed for the production of asphalt or of bituminous or tar macadam and used mainly for the construction, repair or maintenance of roads, or a road planing machine so used.

(3B) Furthermore item 7 does not apply to—

- (a) a semi-trailer which is a car transporter,
- (b) a semi-trailer which is normally used on international journeys any part of which takes place outside the United Kingdom.]

[<sup>F80</sup>(3C) Item 1A and the words “(other than a motor vehicle such as is mentioned in item 1A)” in item 1 of the Table shall cease to have effect after 31st December 2006.]

(4) Where a motor vehicle is drawing—

- (a) two trailers, then only one of those trailers may exceed an overall length of 7 m;
- (b) three trailers, then none of those trailers shall exceed an overall length of 7 m.

(5) Where a motor vehicle is drawing—

- (a) two or more trailers; or
- (b) one trailer constructed and normally used for the conveyance of indivisible loads of exceptional length—

then—

- (i) the overall length of that motor vehicle shall not exceed 9.2 m; and
- (ii) the overall length of the combination of vehicles, calculated in accordance with regulation 81(g) and (h), shall not exceed 25.9 m, unless the conditions specified in paragraphs 1 and 2 of Schedule 12 have been complied with.

[<sup>F81</sup>(5XA) A motor vehicle drawing a trailer which is not a semi-trailer shall (unless it is a vehicle such as is mentioned in item 1A of the Table in paragraph (1)) comply with the requirements of paragraph (5A).

The words in parenthesis in this paragraph shall cease to have effect after 31st December 2006.]

[<sup>F82</sup>(5A) The requirements of this paragraph, in relation to a combination of vehicles, are that at least one of the vehicles in the combination is not a goods vehicle or, if both vehicles in the combination are goods vehicles that—

- (a) the maximum distance measured parallel to the longitudinal axis of the combination of vehicles from the foremost point of the loading area behind the driver’s cab to the rear of the trailer, less the distance between the rear of the motor vehicle and the front of the trailer, does not exceed 15.65m; and
- (b) the maximum distance measured parallel to the longitudinal axis of the combination of vehicles from the foremost point of the loading area behind the driver’s cab to the rear of the trailer does not exceed [<sup>F83</sup>16.4 m];

but sub-paragraph (a) shall not apply if both vehicles in the combination are car transporters.]

[<sup>F84</sup>(6) The requirements of this paragraph, in relation to a semi-trailer, are that—

- (a) the longitudinal distance from the axis of the king pin <sup>F85</sup>... to the rear of the semi-trailer does not exceed—

- (i) 12.5m in the case of a car transporter, or
- (ii) 12m in any other case; and
- (b) no point in the semi-trailer forward of the transverse plane passing through the axis of the king pin <sup>F85</sup>... is more than—
  - (i) 4.19m from the axis of the king pin, in the case of a car transporter, or
  - (ii) 2.04m from the axis of the king pin, in any other case.

[<sup>F86</sup>(6A) For the purposes of paragraph (5A)—

- (a) where the forward end of the loading area of a motor vehicle is bounded by a wall, the thickness of the wall shall be regarded as part of the loading area; and
- (b) any part of a vehicle designed primarily for use as a means of attaching another vehicle to it and any fitting designed for use in connection with any such part shall be disregarded in determining the distance between the rear of a motor vehicle and the front of a trailer being drawn by it.]

(7) For the purpose of paragraph (6) the longitudinal distance from the axis of the king pin to the rear of a semi-trailer is the distance between a transverse plane passing through the axis of the king pin and [<sup>F87</sup>the rear of the semi-trailer].

[<sup>F88</sup>(7A) Where a semi-trailer has more than one king-pin or is constructed so that it can be used with a king-pin in different positions, references in this regulation to a distance from the king-pin shall be construed

- [<sup>F89</sup>(a) in relation to a vehicle which was manufactured after [<sup>F90</sup>1st January 1999], as a reference to the foremost king-pin or, as the case may be, the foremost king-pin position; and
- (b) in relation to any other vehicle, as a reference to the rearmost king-pin or, as the case may be, the rearmost king-pin position.]]

[<sup>F91</sup>(7B) For the purposes of paragraphs (5A), (6) and (7)—

- (a) a reference to the front of a vehicle is a reference to the transverse plane passing through the extreme forward projecting points of the vehicle; and
- (b) a reference to the rear of a vehicle is a reference to the transverse plane passing through the extreme rearward projecting points of the vehicle,

inclusive (in each case) of all parts of the vehicle, of any receptacle which is of a permanent character and accordingly strong enough for repeated use, and any fitting on, or attached to the vehicle but exclusive of—

- (i) the things set out in sub-paragraph (i) of the definition of “overall length” in the Table in regulation 3(2), and
- (ii) in the case of a semi-trailer, the things set out in sub-paragraph (ii)(a) of that definition.]

(8) Where a broken down articulated vehicle is being towed by a motor vehicle in consequence of a breakdown—

- (a) paragraph (5) shall have effect in relation to the combination of vehicles as if sub-paragraph (b) were omitted, and
- (b) for the purposes of paragraph (4) and of paragraph (5) as so modified, the articulated vehicle shall be regarded as a single trailer.]

[<sup>F92</sup>(9) No person shall use or cause or permit to be used on a road, a trailer with an overall length exceeding 18.65m unless the requirements of paragraphs 1 and 2 of Schedule 12 are complied with.]

**Status:** Point in time view as at 31/03/2009.

**Status:** This revised version has been created from an electronic version contributed by Westlaw which was originally derived from the printed publication. **Read more** (See end of Document for details)**Changes to legislation:** There are currently no known outstanding effects for the The Road Vehicles (Construction and Use) Regulations 1986. (See end of Document for details)

## Textual Amendments

- F64** Reg. 7(1) Table Items 1, 1A substituted (1.6.1998) by The Road Vehicles (Construction and Use) (Amendment) (No. 3) Regulations 1998 (S.I. 1998/1188), regs. 1, **4(2)(a)**
- F65** Word in reg. 7 Table substituted (1.4.2003) by The Road Vehicles (Construction and Use) (Amendment) Regulations 2003 (S.I. 2003/182), regs. 1, **3(a)**
- F66** Reg. 7 Table Item 2A inserted (1.4.2003) by The Road Vehicles (Construction and Use) (Amendment) Regulations 2003 (S.I. 2003/182), regs. 1, **3(c)**
- F67** Words in reg. 7(1) Table inserted (19.3.1990) by The Road Vehicles (Construction and Use) (Amendment) Regulations 1990 (S.I. 1990/317), regs. 1, **4(2)(a)**
- F68** Words in reg. 7(1) Table Item 3 inserted (1.6.1998) by The Road Vehicles (Construction and Use) (Amendment) (No. 3) Regulations 1998 (S.I. 1998/1188), regs. 1, **4(2)(b)**
- F69** Words in reg. 7(1) Table inserted (19.3.1990) by The Road Vehicles (Construction and Use) (Amendment) Regulations 1990 (S.I. 1990/317), regs. 1, **4(2)(b)**
- F70** Words in reg. 7 Table added (1.4.2003) by The Road Vehicles (Construction and Use) (Amendment) Regulations 2003 (S.I. 2003/182), regs. 1, **3(b)**
- F71** Reg. 7 Table Item 4A inserted (1.4.2003) by The Road Vehicles (Construction and Use) (Amendment) Regulations 2003 (S.I. 2003/182), regs. 1, **3(c)**
- F72** Reg. 7 Table Item 4B inserted (1.4.2003) by The Road Vehicles (Construction and Use) (Amendment) Regulations 2003 (S.I. 2003/182), regs. 1, **3(c)**
- F73** Words in reg. 7(1) Table inserted (19.3.1990) by The Road Vehicles (Construction and Use) (Amendment) Regulations 1990 (S.I. 1990/317), regs. 1, **4(2)(c)**
- F74** Reg. 7(1) Table inserted (19.3.1990) by The Road Vehicles (Construction and Use) (Amendment) Regulations 1990 (S.I. 1990/317), regs. 1, **4(2)(d)**
- F75** Words in reg. 7(1) Table inserted (19.3.1990) by The Road Vehicles (Construction and Use) (Amendment) Regulations 1990 (S.I. 1990/317), regs. 1, **4(2)(e)**
- F76** Words in reg. 7(2) added (17.10.1991) by The Road Vehicles (Construction and Use) (Amendment) (No. 4) Regulations 1991 (S.I. 1991/2125), regs. 1, **4(3)**
- F77** Reg. 7(3)-(3B) substituted for reg. 7(3) (19.3.1990) by The Road Vehicles (Construction and Use) (Amendment) Regulations 1990 (S.I. 1990/317), regs. 1, **4(3)**
- F78** Word in reg. 7(3) inserted (17.10.1991) by The Road Vehicles (Construction and Use) (Amendment) (No. 4) Regulations 1991 (S.I. 1991/2125), regs. 1, **4(4)**
- F79** Reg. 7(3)(c) and word added (29.6.1990) by The Road Vehicles (Construction and Use) (Amendment) (No. 3) Regulations 1990 (S.I. 1990/1163), regs. 1, **3(2)** (with reg. 2(2))
- F80** Reg. 7(3C) inserted (1.6.1998) by The Road Vehicles (Construction and Use) (Amendment) (No. 3) Regulations 1998 (S.I. 1998/1188), regs. 1, **4(3)**
- F81** Reg. 7(5XA) inserted (1.6.1998) by The Road Vehicles (Construction and Use) (Amendment) (No. 3) Regulations 1998 (S.I. 1998/1188), regs. 1, **4(4)**
- F82** Reg. 7(5A) inserted (17.10.1991) by The Road Vehicles (Construction and Use) (Amendment) (No. 4) Regulations 1991 (S.I. 1991/2125), regs. 1, **4(5)**
- F83** Word in reg. 7(5A)(b) substituted (1.6.1998) by The Road Vehicles (Construction and Use) (Amendment) (No. 3) Regulations 1998 (S.I. 1998/1188), regs. 1, **4(5)**
- F84** Reg. 7(6)-(8) substituted for reg. 7(6) (19.3.1990) by The Road Vehicles (Construction and Use) (Amendment) Regulations 1990 (S.I. 1990/317), regs. 1, **4(4)**
- F85** Words in reg. 7(6)(a)(b) omitted (29.6.1990) by virtue of The Road Vehicles (Construction and Use) (Amendment) (No. 3) Regulations 1990 (S.I. 1990/1163), regs. 1, **3(3)** (with reg. 2(2))
- F86** Reg. 7(6A) inserted (17.10.1991) by The Road Vehicles (Construction and Use) (Amendment) (No. 4) Regulations 1991 (S.I. 1991/2125), regs. 1, **4(6)**
- F87** Words in reg. 7(7) substituted (17.10.1991) by The Road Vehicles (Construction and Use) (Amendment) (No. 4) Regulations 1991 (S.I. 1991/2125), regs. 1, **4(7)**
- F88** Reg. 7(7A) inserted (29.6.1990) by The Road Vehicles (Construction and Use) (Amendment) (No. 3) Regulations 1990 (S.I. 1990/1163), regs. 1, **3(4)** (with reg. 2(2))



**Status:** This revised version has been created from an electronic version contributed by Westlaw which was originally derived from the printed publication. **Read more** (See end of Document for details)**Changes to legislation:** There are currently no known outstanding effects for the The Road Vehicles (Construction and Use) Regulations 1986. (See end of Document for details)

- F89** Words in reg. 7(7A) substituted (1.6.1998) by The Road Vehicles (Construction and Use) (Amendment) (No. 3) Regulations 1998 (S.I. 1998/1188), regs. 1, 4(6)
- F90** Words in reg. 7(7A)(a) substituted (1.1.1999) by The Road Vehicles (Construction and Use) (Amendment) (No. 7) Regulations 1998 (S.I. 1998/3112), regs. 1, 4
- F91** Reg. 7(7B) inserted (17.10.1991) by The Road Vehicles (Construction and Use) (Amendment) (No. 4) Regulations 1991 (S.I. 1991/2125), regs. 1, 4(8)
- F92** Reg. 7(9) inserted (17.10.1991) by The Road Vehicles (Construction and Use) (Amendment) (No. 4) Regulations 1991 (S.I. 1991/2125), regs. 1, 4(9)

#### Commencement Information

- I6** Reg. 7 in force at 11.8.1986, see [reg. 1](#)

#### Width

8.—(1) Save as provided in paragraph (2), the overall width of a vehicle of a class specified in an item in column 2 of the Table shall not exceed the maximum width specified in column 3 in that item.

**TABLE**

(regulation 8(1))

<i>1</i> <i>Item</i>	<i>2</i> <i>Class of vehicle</i>	<i>3</i> <i>Maximum width (metres)</i>
1	A locomotive, other than an agricultural motor vehicle.	2.75
2	A refrigerated vehicle	[ <sup>F93</sup> 2.60]
3	Any other motor vehicle.	[ <sup>F94</sup> 2.55]
4	A trailer drawn by a motor vehicle having a maximum gross weight (determined as provided in Part I of Schedule 8 to these Regulations) exceeding 3500 kg.	[ <sup>F94</sup> 2.55]
5	An agricultural trailer.	[ <sup>F94</sup> 2.55]
6	An agricultural trailed appliance.	[ <sup>F94</sup> 2.55]
7	Any other trailer drawn by a vehicle other than a motor cycle.	2.3
8	A trailer drawn by a motor cycle.	1.5

(2) Paragraph (1) does not apply to a broken down vehicle which is being drawn in consequence of the breakdown.

(3) No person shall use or cause or permit to be used on a road a wheeled agricultural motor vehicle drawing a wheeled trailer if, when the longitudinal axes of the vehicles are parallel but in different vertical planes, the overall width of the two vehicles, measured as if they were one vehicle, exceeds [<sup>F95</sup>2.55] metres.

(4) In this regulation “refrigerated vehicle” means any vehicle which is specially designed for the carriage of goods at low temperature and of which the thickness of each of the side walls, inclusive of insulation, is at least 45 mm.

**Status:** Point in time view as at 31/03/2009.

**Status:** This revised version has been created from an electronic version contributed by Westlaw which was originally derived from the printed publication. **Read more** (See end of Document for details)**Changes to legislation:** There are currently no known outstanding effects for the The Road Vehicles (Construction and Use) Regulations 1986. (See end of Document for details)

### Textual Amendments

- F93** Word in reg. 8(1) Table substituted (1.1.1989) by The Road Vehicles (Construction and Use) (Amendment) (No. 7) Regulations 1988 (S.I. 1988/1871), regs. 1, **3** (with reg. 2(2))
- F94** Word in reg. 8(1) Table substituted (1.1.1996) by The Road Vehicles (Construction and Use) (Amendment) (No. 6) Regulations 1995 (S.I. 1995/3051), regs. 1, **4(2)**
- F95** Word in reg. 8(3) substituted (1.1.1996) by The Road Vehicles (Construction and Use) (Amendment) (No. 6) Regulations 1995 (S.I. 1995/3051), regs. 1, **4(3)**

### Commencement Information

- I7** Reg. 8 in force at 11.8.1986, see reg. 1

## Height

**9.—(1)** The overall height of a bus shall not exceed 4.57 m.

**F96**(2) .....

**F97**(2A) .....

**F98**(3) .....

### Textual Amendments

- F96** Reg. 9(2) omitted (1.6.1995) by virtue of The Road Vehicles (Construction and Use) (Amendment) (No. 3) Regulations 1995 (S.I. 1995/1201), regs. 1, **3**
- F97** Reg. 9(2A) omitted (1.6.1995) by virtue of The Road Vehicles (Construction and Use) (Amendment) (No. 3) Regulations 1995 (S.I. 1995/1201), regs. 1, **3**
- F98** Reg. 9(3) omitted (1.6.1995) by virtue of The Road Vehicles (Construction and Use) (Amendment) (No. 3) Regulations 1995 (S.I. 1995/1201), regs. 1, **3**

### Commencement Information

- I8** Reg. 9 in force at 11.8.1986, see reg. 1

## Indication of overall travelling height

**[<sup>F99</sup>10.—(1)** Subject to the provisions of this regulation, no person shall drive or cause or permit to be driven on a road a motor vehicle with an overall travelling height exceeding 3m unless a notice is displayed in the cab, in such a manner that it can easily be read by the driver, and the notice meets the requirements of paragraph (3).

(2) Subject to the provisions of this regulation, no person shall use or cause or permit to be used on a road a motor vehicle with an overall travelling height exceeding 3m if any letters or numbers are displayed in the cab, otherwise than in a notice which meets the requirements of paragraph (3)—

- (a) where they could be read by the driver; and
  - (b) which could be understood as indicating a height associated with the vehicle or any trailer drawn by it.
- (3) The requirements of this paragraph in respect of a notice are that—
- (a) the notice gives an indication of vehicle height expressed in feet and inches, or in both feet and inches and in metres;
  - (b) the numbers giving the indication in feet and inches are at least 40mm tall;

- (c) the height expressed in feet and inches and (where applicable) the height expressed in metres are—
    - (i) if the vehicle is a vehicle to which regulation 10A applies, not less than the predetermined height mentioned in regulation 10A (2)(a) or the overall travelling height (whichever is the greater), or
    - (ii) if the vehicle is not a vehicle to which regulation 10A applies, not less than the overall travelling height;
  - (d) if the vehicle is not a relevant vehicle, the height expressed in feet and inches does not exceed the overall travelling height by more than 150mm;
  - (e) if the vehicle is a relevant vehicle, the height expressed in feet and inches does not exceed the overall travelling height by more than 1m;
  - (f) if the height is expressed in both feet and inches and in metres, the height expressed in feet and inches and the height expressed in metres do not differ by more than 50mm; and
  - (g) no other letters or numbers which could be understood as being an indication of any height associated with the vehicle or any trailer drawn by it are displayed in the notice.
- (4) Paragraph (1) shall not apply if, having regard to the lengths of road which the driver might drive along in the course of fulfilling the purpose of the journey taking into account any possibility of unforeseen diversions and the driver having difficulty in finding his way, it is highly unlikely that the driver would during the course of the journey encounter any bridge or other overhead structure which does not exceed by at least 1m—
- (a) in the case of a vehicle to which regulation 10A applies, the maximum travelling height.; or
  - (b) in any other case, the overall travelling height.
- (5) Paragraph (1) shall not apply to a vehicle on a particular journey and at a particular time if—
- (a) one or more documents are being carried in the vehicle which are within the easy reach of the driver and that or those documents describe a route or a choice of routes which the driver must take in order to fulfil the purpose of the journey without risk of the vehicle, its load or equipment or any trailer drawn by the vehicle, its load or equipment, colliding with any bridge or other overhead structure; and
  - (b) the vehicle is on such a route which is so described or is off that route by reason of a diversion that could not reasonably have been foreseen at the beginning of the journey.
- (6) Paragraph (1) shall not apply to a vehicle on a particular journey if—
- (a) one or more documents are being carried in the vehicle which are within the easy reach of the driver and that or those documents contain information as to—
    - (i) the height of bridges and other overhead structures under which the vehicle and any trailer drawn by it could pass, and
    - (ii) the height of bridges and other overhead structures under which the vehicle and any trailer drawn by it could not pass,without the vehicle, its load or equipment or any such trailer, its load or equipment, colliding with any bridge or other overhead structure; and
  - (b) the information is such that, having regard in particular to the matters referred to in paragraph (7), it would enable any driver to fulfil the purpose of the journey without there being any risk of the vehicle, its load or equipment or any trailer, its load or equipment, colliding with any bridge or other overhead structure while on the journey.
- (7) The matters referred to in paragraph (6) are—

**Status:** Point in time view as at 31/03/2009.

**Status:** This revised version has been created from an electronic version contributed by Westlaw which was originally derived from the printed publication. **Read more** (See end of Document for details)**Changes to legislation:** There are currently no known outstanding effects for the The Road Vehicles (Construction and Use) Regulations 1986. (See end of Document for details)

- (a) the roads which the driver might drive along in the course of fulfilling the purpose of the journey taking into account any possibility of unforeseen diversions and of the driver having difficulty in finding his way;
  - (b) the height of bridges and other overhead structures that would be encountered were the vehicle to proceed along any of those roads; and
  - (c) the setting of any device of a description specified in regulation 10A(2).
- (8) Paragraphs (1) and (2) shall not apply to motor vehicle if it has an overall travelling height of not more than 4m and—
- (a) it is a vehicle registered or put into circulation in an EEA State and is being used in international traffic; or
  - (b) it is a motor vehicle drawing a trailer registered or put into circulation in an EEA State and that trailer is being used in international traffic.
- (9) For the purposes of this regulation—
- (a) “EEA State”, and “high level equipment” and “maximum travelling height” have the meanings given in regulation 10C;
  - (b) “overall travelling height” in relation to a motor vehicle means—
    - (i) if it is not drawing a trailer, the overall height for the time being of the vehicle, its equipment and load, or
    - (ii) if it is drawing one or more trailers, the overall height for the time being of the combination of vehicles, their equipment and loads.
  - (c) a motor vehicle is a “relevant vehicle” if at any particular time—
    - (i) the vehicle or any trailer drawn by it is fitted with high level equipment with a maximum, height of more than 3m; and
    - (ii) the overall travelling height is less than the maximum travelling height.
- (10) In paragraph (8), “international traffic” and “registered or put into circulation” have the same meanings as in article 3 of Community Directive 85/3.

#### Textual Amendments

**F99** Regs. 10-10C substituted for reg. 10 (1.10.1997) by [The Road Vehicles \(Construction and Use\) \(Amendment\) Regulations 1997 \(S.I. 1997/530\)](#), reg. 1(1), **Sch.**

#### Warning devices where certain high level equipment is fitted to a vehicle

**10A.—**(1) Subject to the provisions of this regulation and regulations 10B and 10C, no person shall drive or cause or permit to be driven on a road a vehicle to which this regulation applies unless the vehicle is fitted with a warning device and the requirements specified in paragraph (2) are satisfied in respect of the device, the vehicle and any relevant trailer drawn by the vehicle.

- (2) The requirements are—
- (a) that the device, the vehicle and any relevant trailer drawn by it shall be so constructed, maintained and adjusted, and the connections between the vehicle and those trailers are such, that the device would give a visible warning to the driver if, whilst the vehicle was being driven, the height of the highest point of any high level equipment fitted to the vehicle or any of those trailers were to exceed a predetermined height; and
  - (b) the predetermined height referred to in sub-paragraph (a) shall not exceed the overall travelling height by more than 1m.

**Status:** This revised version has been created from an electronic version contributed by Westlaw which was originally derived from the printed publication. **Read more** (See end of Document for details)**Changes to legislation:** There are currently no known outstanding effects for the The Road Vehicles (Construction and Use) Regulations 1986. (See end of Document for details)

- (3) No person shall be taken to have failed to comply with paragraph (1) on the ground that a motor vehicle or a relevant trailer was not fitted with a warning device and the requirements in paragraph (2) were not being satisfied as mentioned in paragraph (1)—
- (a) before 1st October 1998—
- (i) if the motor vehicle was first used before 1st April 1998; or
  - (ii) the relevant trailer was manufactured before that date; or
- (b) before 1st April 1998 in relation to any other motor vehicle or relevant trailer.

(4) Paragraph (1) shall not apply in relation to a particular journey if, having regard to the lengths of road which the driver might drive along in the course of fulfilling the purpose of the journey and taking into account any possibility of unforeseen diversions and the driver having difficulty in finding his way, it is highly unlikely that the driver would during the course of the journey be confronted with any bridge or other overhead structure which does not exceed the maximum travelling height by at least 1m.

#### Textual Amendments

**F99** Regs. 10-10C substituted for reg. 10 (1.10.1997) by [The Road Vehicles \(Construction and Use\) \(Amendment\) Regulations 1997 \(S.I. 1997/530\)](#), reg. 1(1), **Sch.**

#### Vehicles to which regulation 10A applies

- 10B.**—(1) Subject to the provisions of this regulation, regulation 10A applies to—
- (a) a motor vehicle first used on or after 1st April 1993, if the vehicle or any relevant trailer drawn by it, is fitted with high level equipment with a maximum height of more than 3m; and
- (b) a motor vehicle first used before 1st April 1993, if any relevant trailer drawn by it is fitted with such equipment.
- (2) Regulation 10A does not apply to a motor vehicle if it has an overall travelling height of not more than 4m and—
- (a) it is a vehicle registered or put into circulation in an EEA State and is being used in international traffic; or
- (b) it is a motor vehicle drawing a trailer registered or put into circulation in an EEA State and that trailer is being used in international traffic, and
- in this paragraph, “international traffic” and “registered or put into circulation” have the same meanings as in article 3 of Community Directive 85/3.
- (3) Regulation 10A does not apply to—
- (a) an agricultural motor vehicle;
  - (a) an industrial tractor;
  - (c) a works truck;
  - (d) a motor vehicle owned by the Secretary of State for Defence and used for naval, military or air force purposes or a motor vehicle so used while being driven by a person for the time being subject to orders of a member of the armed forces of the Crown;
  - (e) a motor vehicle drawing a trailer owned by the Secretary of State for Defence and used for naval, military or air force purposes or a motor vehicle drawing such a trailer while being driven by a person for the time being subject to orders of a member of the armed forces of the Crown;

**Status:** Point in time view as at 31/03/2009.

**Status:** This revised version has been created from an electronic version contributed by Westlaw which was originally derived from the printed publication. **Read more** (See end of Document for details)**Changes to legislation:** There are currently no known outstanding effects for the The Road Vehicles (Construction and Use) Regulations 1986. (See end of Document for details)

- (f) [<sup>F100</sup>a motor vehicle used by a fire brigade maintained under the Fire Services Act 1947][<sup>F100</sup>a motor vehicle used by employees of a relevant authority (as defined in section 6 of the Fire (Scotland) Act 2005 (asp 5)) for the purposes of that authority under that Act][<sup>F101</sup>or, in England or Wales, a motor vehicle used by employees of a fire and rescue authority for the purposes of that authority under the Fire and Rescue Services Act 2004][<sup>F102</sup>or, in England, a motor vehicle used by employees of a fire and rescue authority for the purposes of that authority under the Fire and Rescue Services Act 2004];
- (g) a motor vehicle that is constructed and normally used for the purpose of carrying at least two other vehicles;
- (h) a motor vehicle drawing a car transporter; or
- (i) a motor vehicle whose maximum travelling height does not exceed its overall travelling height.

#### Textual Amendments

- F99** Regs. 10-10C substituted for reg. 10 (1.10.1997) by [The Road Vehicles \(Construction and Use\) \(Amendment\) Regulations 1997 \(S.I. 1997/530\)](#), reg. 1(1), **Sch.**
- F100** Words in [reg. 10B\(3\)\(f\)](#) substituted (S.) (2.8.2005) by [The Fire \(Scotland\) Act 2005 \(Consequential Modifications and Amendments\) \(No. 2\) Order 2005 \(S.S.I. 2005/344\)](#), art. 1, **sch. para. 5(2)**; S.S.I. 2005/392, **art. 2**
- F101** Words in [reg. 10B\(3\)\(f\)](#) inserted (W.) (25.10.2005) by [The Fire and Rescue Services Act 2004 \(Consequential Amendments\) \(Wales\) Order 2005 \(S.I. 2005/2929\)](#), arts. 1(1), **11(2)**
- F102** Words in [reg. 10B\(3\)\(f\)](#) inserted (E.) (30.12.2004) by [The Fire and Rescue Services Act 2004 \(Consequential Amendments\) \(England\) Order 2004 \(S.I. 2004/3168\)](#), arts. 1(1), **10(2)**

#### Interpretation of regulations 10A and 10B

**10C.**—(1) The following provisions of this regulation apply for the interpretation of this regulation and regulations 10A and 10B.

(2) Subject to paragraphs (4) and (5), a reference to high level equipment, in relation to a motor vehicle, is a reference to equipment which is so fitted to the vehicle that—

- (a) the equipment can be raised by means of a power operated device, and
- (b) the raising or lowering of the equipment is capable of altering the overall travelling height of the motor vehicle when the vehicle and every trailer drawn by it is unladen.

(3) Subject to paragraph (4) and (5), a reference to high level equipment, in relation to a trailer drawn by a motor vehicle, is a reference to equipment which is so fitted to the trailer that—

- (a) the equipment can be raised by means of a power operated device, and
- (b) the raising or lowering of the equipment is capable of altering the overall travelling height of the motor vehicle when the vehicle and every trailer drawn by it is unladen.

(4) A reference to high level equipment in relation to a tipper which is—

- (a) a motor vehicle first used before 1st April 1998, or
- (b) a trailer manufactured before that date,

shall be construed as not including the relevant part of the tipper.

(5) Where equipment fitted to a vehicle would otherwise be high level equipment, that equipment shall not be regarded as high level equipment if—

- (a) the equipment is so designed and constructed that—

- (i) it can be fixed in a stowed position by a locking device when travelling; and
  - (ii) it is not possible for a person in the cab to interfere with the locking device; and
  - (b) the equipment is fixed in that position by the locking device.
- (6) The following expressions shall bear the following meanings—
- (a) “EEA State” means a state which is a contracting party to the EEA Agreement; and
  - (b) “EEA Agreement” means the Agreement on the European Economic Area signed at Oporto on 2 May 1992 as adjusted by the Protocol signed at Brussels on 17 March 1993;
  - (c) “maximum height”, in relation to any high level equipment fitted to a vehicle, means the height of the highest point of that equipment above the ground when it is raised as far as possible by means of that device and the vehicle is unladen;
  - (d) “maximum travelling height”, in relation to a motor vehicle to which regulation 10A applies, means—
    - (i) if the overall travelling height could be increased by raising any high level equipment fitted to the vehicle or to any relevant trailer drawn by <sup>F103</sup>it that is not for the time being at its maximum height, the greatest overall travelling height that could be achieved by raising such equipment (without making any other changes to the vehicle, its load or equipment or to any trailer drawn by it, its load or equipment); or
    - (ii) in any other case, the overall travelling height;
  - (e) “overall travelling height” has the meaning given by regulation 10(9)(b);
  - (f) “relevant part”, in relation to a tipper, shall be construed in accordance with subparagraph (g);
  - (g) “tipper” means a vehicle that is so constructed that it can be unloaded by part of the vehicle (in this regulation referred to as the “relevant part”) being tipped sideways or rearwards, and
- a reference to equipment fitted to a vehicle includes part of the vehicle.
- (7) “Relevant trailer” means a trailer manufactured on or after 1st April 1993 not being—
- (a) an agricultural trailer;
  - (b) an agricultural trailed appliance;
  - (c) a works trailer;
  - (d) a trailer used by <sup>F104</sup>a fire brigade maintained under the Fire Services Act 1947]<sup>F104</sup>employees of a relevant authority (as defined in section 6 of the Fire (Scotland) Act 2005 (asp 5)) for the purposes of that authority under that Act]<sup>F105</sup>or, in England or Wales, a trailer used by employees of a fire and rescue authority for the purposes of that authority under the Fire and Rescue Services Act 2004]<sup>F106</sup>or, in England, a trailer used by employees of a fire and rescue authority for the purposes of that authority under the Fire and Rescue Services Act 2004];
  - (e) a broken down vehicle (including an articulated vehicle) being drawn by a motor vehicle in consequence of a breakdown.]

#### Textual Amendments

**F99** Regs. 10-10C substituted for reg. 10 (1.10.1997) by [The Road Vehicles \(Construction and Use\) \(Amendment\) Regulations 1997 \(S.I. 1997/530\)](#), reg. 1(1), [Sch.](#)

**F103** Word in reg. 10C(6)(d)(i) inserted (1.6.1998) by [The Road Vehicles \(Construction and Use\) \(Amendment\) \(No. 3\) Regulations 1998 \(S.I. 1998/1188\)](#), regs. 1, 5

**Status:** Point in time view as at 31/03/2009.

**Status:** This revised version has been created from an electronic version contributed by Westlaw which was originally derived from the printed publication. **Read more** (See end of Document for details)**Changes to legislation:** There are currently no known outstanding effects for the The Road Vehicles (Construction and Use) Regulations 1986. (See end of Document for details)

- F104** Words in reg. 10C(7)(d) substituted (S.) (2.8.2005) by The Fire (Scotland) Act 2005 (Consequential Modifications and Amendments) (No. 2) Order 2005 (S.S.I. 2005/344), art. 1, **sch. para. 5(3)**; S.S.I. 2005/392, **art. 2**
- F105** Words in reg. 10C(7)(d) inserted (W.) (25.10.2005) by The Fire and Rescue Services Act 2004 (Consequential Amendments) (Wales) Order 2005 (S.I. 2005/2929), arts. 1(1), **11(3)**
- F106** Words in reg. 10C(7)(d) inserted (E.) (30.12.2004) by The Fire and Rescue Services Act 2004 (Consequential Amendments) (England) Order 2004 (S.I. 2004/3168), arts. 1(1), **10(3)**

## Overhang

**11.—(1)** The overhang of a wheeled vehicle of a class specified in an item in column 2 of the Table shall not, subject to any exemption specified in that item in column 4, exceed the distance specified in that item in column 3.

### TABLE

(regulation 11(1))

<i>1</i> <i>Item</i>	<i>2</i> <i>Class of vehicle</i>	<i>3</i> <i>Maximum overhang</i>	<i>4</i> <i>Exemptions</i>
1	Motor tractor	1.83 m.	(a) a track-laying vehicle  (b) an agricultural motor vehicle
2	Heavy motor car and motor car	60% of the distance between the transverse plane which passes through the centre or centres of the foremost wheel or wheels and the transverse plane which passes through the foremost point from which the overhang is to be measured as provided in regulation 3(2).	(a) a bus (b) a refuse vehicle (c) a works truck (d) a track-laying vehicle (e) an agricultural motor vehicle (f) a motor car which is an ambulance (g) a vehicle designed to dispose of its load to the rear, if the overhang does not exceed 1.15 m (h) a vehicle first used before 2nd January 1933 (i) a vehicle first used before 1st January 1966 if— (i) the distance between the centres of the rearmost and foremost axles does not exceed 2.29 m, and (ii) the distance specified in column 3 is not exceeded by more than 76 mm



**Status:** This revised version has been created from an electronic version contributed by Westlaw which was originally derived from the printed publication. **Read more** (See end of Document for details)**Changes to legislation:** There are currently no known outstanding effects for the The Road Vehicles (Construction and Use) Regulations 1986. (See end of Document for details)

1 Item	2 Class of vehicle	3 Maximum overhang	4 Exemptions
			(j) heating plant on a vehicle designed and mainly used to heat the surface of a road or other similar surface in the process of construction, repair or maintenance shall be disregarded.

(2) In the case of an agricultural motor vehicle the distance measured horizontally and parallel to the longitudinal axis of the rear portion of the vehicle between the transverse planes passing through the rearmost point of the vehicle and through the centre of the rear or the rearmost axle shall not exceed 3 m.

[<sup>F107</sup>(3) A heavy motor car shall be taken to comply with the requirements of paragraph (1) if it meets the requirements of paragraph 7.6.2 of Annex I of Community Directive 97/27.]

#### Textual Amendments

**F107** [Reg. 11\(3\)](#) inserted (1.6.1998) by [The Road Vehicles \(Construction and Use\) \(Amendment\) \(No. 3\) Regulations 1998 \(S.I. 1998/1188\)](#), regs. 1, 6

#### Commencement Information

**I9** [Reg. 11](#) in force at 11.8.1986, see [reg. 1](#)

### Minimum ground clearance

12.—(1) Save as provided in paragraph (2), a wheeled trailer which is—

- (a) a goods vehicle; and
- (b) manufactured on or after 1st April 1984,

shall have a minimum ground clearance of not less than 160 mm if the trailer has an axle interspace of more than 6 m but less than 11.5 m, and a minimum ground clearance of not less than 190 mm if the trailer has an axle interspace of 11.5 m or more.

(2) Paragraph (1) shall not apply in the case of a trailer—

- (a) which is fitted with a suspension system with which, by the operation of a control, the trailer may be lowered or raised, while that system is being operated to enable the trailer to pass under a bridge or other obstruction over a road provided that at such times the system is operated so that no part of the trailer (excluding any wheel) touches the ground or is likely to do so; or
- (b) while it is being loaded or unloaded.

(3) In this regulation—

“axle interspace” means—

- (a) in the case of a semi-trailer, the distance between the point of support of the semi-trailer at its forward end and, if it has only one axle, the centre of that axle or, if it has more than one axle, the point halfway between the centres of the foremost and rearmost of those axles; and

**Status:** Point in time view as at 31/03/2009.

**Status:** This revised version has been created from an electronic version contributed by Westlaw which was originally derived from the printed publication. **Read more** (See end of Document for details)**Changes to legislation:** There are currently no known outstanding effects for the The Road Vehicles (Construction and Use) Regulations 1986. (See end of Document for details)

- (b) in the case of any other trailer, the distance between the centre of its front axle or, if it has more than one axle at the front, the point halfway between the centres of the foremost and rearmost of those axles, and the centre of its rear axle or, if it has more than one axle at the rear, the point halfway between the centre of the foremost and rearmost of those axles; and

“ground clearance” means the shortest distance between the ground and the lowest part of that portion of the trailer (excluding any part of a suspension, steering or braking system attached to any axle, any wheel and any air skirt) which lies within the area formed by the overall width of the trailer and the middle 70% of the axle interspace, such distance being ascertained when the trailer—

- (a) is fitted with suitable tyres which are inflated to a pressure recommended by the manufacturer, and
- (b) is reasonably horizontal and standing on ground which is reasonably flat.

#### Commencement Information

**I10** Reg. 12 in force at 11.8.1986, see [reg. 1](#)

#### [<sup>F108</sup>Turning circle—buses]

**13.—(1)** This regulation applies to a bus first used on or after 1st April 1982.

(2) Every vehicle to which this regulation applies shall be able to move on either lock so that [<sup>F109</sup>, both with and without all its wheels in contact with the ground,] no part of it projects outside the area contained between concentric circles with radii of [<sup>F110</sup>12.5 m] and 5.3 m.

[<sup>F111</sup>(2A) In relation to a vehicle manufactured before 1st June 1998 paragraph (2) shall have effect as if the words “, both with and without all its wheels in contact with the ground,” were omitted.]

(3) When a vehicle to which this regulation applies moves forward from rest, on either lock, so that its outermost point describes a circle of [<sup>F112</sup>12.5 m] radius, no part of the vehicle shall project beyond the longitudinal plane which, at the beginning of the manoeuvre, defines the overall width of the vehicle on the side opposite to the direction in which it is turning by more than—

- (a) 0.8 m if it is a rigid vehicle [<sup>F113</sup>of 12m or less in overall length]; or
- (b) 1.2 m if it is [<sup>F114</sup>a rigid bus of over 12m in overall length or] an articulated bus.

(4) For the purpose of paragraph (3) the two rigid portions of an articulated bus shall be in line at the beginning of the manoeuvre.

#### Textual Amendments

**F108** Reg. 13 heading substituted (19.3.1990) by The Road Vehicles (Construction and Use) (Amendment) Regulations 1990 (S.I. 1990/317), regs. 1, **5(1)** (with reg. 2(a))

**F109** Words in reg. 13(2) inserted (1.6.1998) by The Road Vehicles (Construction and Use) (Amendment) (No. 3) Regulations 1998 (S.I. 1998/1188), regs. 1, **7(2)(a)**

**F110** Word in reg. 13(2) substituted (1.6.1998) by The Road Vehicles (Construction and Use) (Amendment) (No. 3) Regulations 1998 (S.I. 1998/1188), regs. 1, **7(2)(b)**

**F111** Reg. 13(2A) inserted (1.6.1998) by The Road Vehicles (Construction and Use) (Amendment) (No. 3) Regulations 1998 (S.I. 1998/1188), regs. 1, **7(3)**

**F112** Word in reg. 13(3) substituted (1.6.1998) by The Road Vehicles (Construction and Use) (Amendment) (No. 3) Regulations 1998 (S.I. 1998/1188), regs. 1, **7(4)**

**Status:** This revised version has been created from an electronic version contributed by Westlaw which was originally derived from the printed publication. **Read more** (See end of Document for details)**Changes to legislation:** There are currently no known outstanding effects for the The Road Vehicles (Construction and Use) Regulations 1986. (See end of Document for details)

**F113** Words in reg. 13(3)(a) inserted (1.4.2003) by The Road Vehicles (Construction and Use) (Amendment) Regulations 2003 (S.I. 2003/182), regs. 1, **4(1)**

**F114** Words in reg. 13(3)(b) inserted (1.4.2003) by The Road Vehicles (Construction and Use) (Amendment) Regulations 2003 (S.I. 2003/182), regs. 1, **4(1)**

#### Commencement Information

**I11** Reg. 13 in force at 11.8.1986, see **reg. 1**

### [<sup>F115</sup>Turning circle—articulated vehicles other than those incorporating a car transporter

[<sup>F116</sup>**13A.**—(1) Every vehicle to which this regulation applies shall be able to move on either lock so that, both with and without all its wheels in contact with the surface of the road and disregarding the things set out in paragraphs (a) to (m) in the definition of “overall width” and in paragraph (i)(a) to (o) in the definition of “overall length” in the Table in regulation 3, no part of it projects outside the area contained between concentric circles with radii of 12.5m and 5.3m.

(2) This regulation applies to all articulated vehicles except the following:

- (a) an articulated vehicle, the semi-trailer of which—
  - (i) was manufactured before 1st April 1990 and has an overall length that does not exceed the overall length it had on that date,
  - (ii) is a car transporter,
  - (iii) is a low loader,
  - (iv) is a stepframe low loader, or
  - (v) is constructed and normally used for the conveyance of indivisible loads of exceptional length;
- (b) an articulated vehicle having an overall length not exceeding 15.5m and of which the drawing vehicle was first used before 1st June 1998 or the trailer was first used before that date; or
- (c) an articulated vehicle when an axle of the trailer is raised to aid traction.

(3) In relation to a vehicle manufactured before 1st June 1998, paragraph (1) shall have effect as if the words “both with and without all its wheels in contact with the surface of the road and” were omitted.

(4) An articulated vehicle shall be taken to comply with paragraph (1) if the semi-trailer comprised in it is, by virtue of paragraph 7.6.1.2 of Annex 1 of Community Directive 97/27/EC, deemed to comply with paragraph 7.6.1 of that Annex.]

#### Textual Amendments

**F115** Regs. 13A, 13B inserted (19.3.1990) by The Road Vehicles (Construction and Use) (Amendment) Regulations 1990 (S.I. 1990/317), regs. 1, **5(2)** (with reg. 2(a))

**F116** Reg. 13A substituted (1.1.2001) by The Road Vehicles (Construction and Use) (Amendment) (No. 3) Regulations 2000 (S.I. 2000/3197), regs. 1, **3**

### Turning circle—articulated vehicles incorporating a car transporter

**13B.**—(1) Subject to paragraphs (2) and (3) this regulation applies to an articulated vehicle having an overall length exceeding 15.

5m, the semi-trailer of which is a car transporter.

**Status:** Point in time view as at 31/03/2009.

**Status:** This revised version has been created from an electronic version contributed by Westlaw which was originally derived from the printed publication. **Read more** (See end of Document for details)**Changes to legislation:** There are currently no known outstanding effects for the The Road Vehicles (Construction and Use) Regulations 1986. (See end of Document for details)

(2) This regulation does not apply to an articulated vehicle, the semi-trailer of which satisfied the following conditions—

- (a) it was manufactured before the 1st April 1990, and
- (b) the distance from the front of the trailer to the rearmost axle is no greater than it was on that date.

(3) This regulation does not apply to an articulated vehicle the semi-trailer of which is—

- (a) a low loader, or
- (b) a stepframe low loader.

(4) Every articulated vehicle to which this regulation applies shall be able to move on either lock so that, [F117 both with and without all its wheels in contact with the surface of the road and] disregarding the things set out in [F118 paragraphs (a) to (m) in the definition of “overall width” and in paragraph (i)(a) to (o) in the definition of “overall length”] in the Table in regulation 3(2), no part of—

- (a) the motor vehicle drawing the car transporter, or
- (b) the car transporter to the rear of the transverse plane passing through the king pin,

projects outside the area between concentric circles with radii of 12.5m and 5.3m.

[F119] (5) In relation to a vehicle manufactured before 1st June 1998 paragraph (4) shall have effect as if the words “both with and without all its wheels in contact with the surface of the road” were omitted.

(6) An articulated vehicle shall be taken to comply with paragraph (4) if the semi-trailer comprised in it is, by virtue of paragraph 7.6.1.2 of Annex 1 of Community Directive 97/27/EC, deemed to comply with paragraph 7.6.1 of that Annex.]]

#### Textual Amendments

- F115** Regs. 13A, 13B inserted (19.3.1990) by [The Road Vehicles \(Construction and Use\) \(Amendment\) Regulations 1990 \(S.I. 1990/317\)](#), regs. 1, **5(2)** (with reg. 2(a))
- F117** Words in reg. 13B(4) inserted (1.6.1998) by [The Road Vehicles \(Construction and Use\) \(Amendment\) \(No. 3\) Regulations 1998 \(S.I. 1998/1188\)](#), regs. 1, **9(2)(a)**
- F118** Words in reg. 13B(4) substituted (1.6.1998) by [The Road Vehicles \(Construction and Use\) \(Amendment\) \(No. 3\) Regulations 1998 \(S.I. 1998/1188\)](#), regs. 1, **9(2)(b)**
- F119** Reg. 13B(5)(6) inserted (1.6.1998) by [The Road Vehicles \(Construction and Use\) \(Amendment\) \(No. 3\) Regulations 1998 \(S.I. 1998/1188\)](#), regs. 1, **9(3)**

#### [F120] Turning circle—heavy motor car

**13C.—**(1) This regulation applies to a vehicle which—

- (a) is a heavy motor car or a vehicle combination which consists of a heavy motor car drawing one trailer which is not a semi-trailer;
- (b) was manufactured or, in the case of a vehicle combination, the part consisting of a heavy motor car, was manufactured after 31st May 1998; and
- (c) is not a vehicle falling within any of the descriptions specified in paragraph (2).

(2) The descriptions of vehicle referred to in paragraph (1)(c) are—

- (a) a vehicle having 4 or more axles where the distance between the foremost and rearmost axles exceeds 6.4 metres;
- (b) a vehicle or a vehicle combination to which regulation 13, 13A or 13B applies;

(c) a vehicle constructed and normally used for the carriage of indivisible loads of abnormal length.

(3) Every vehicle to which this regulation applies shall be able to move on either lock so that, both with and without all its wheels in contact with the surface of the road and disregarding the things set out in paragraphs (a) to (m) in the definition of “overall width” and in paragraph (i)(a) to (o) in the definition of “overall length” in the Table in regulation 3(2), no part of it projects outside the area contained between concentric circles with radii of 12.5 m and 5.3 m.]

#### Textual Amendments

**F120** Reg. 13C inserted (1.6.1998) by The Road Vehicles (Construction and Use) (Amendment) (No. 3) Regulations 1998 (S.I. 1998/1188), regs. 1, 10

### Connecting sections and direction-holding of articulated buses

14.—(1) This regulation applies to every articulated bus first used on or after 1st April 1982.

(2) The connecting section of the two parts of every articulated bus to which this regulation applies shall be constructed so as to comply with the provisions relating to such a section specified in paragraph 5.9 in ECE Regulation 36 as regards vehicles within the scope of that Regulation.

(3) Every articulated bus to which this regulation applies shall be constructed so that when the vehicle is moving in a straight line the longitudinal median planes of its two parts coincide and form a continuous plane without any deflection.

#### Commencement Information

**I12** Reg. 14 in force at 11.8.1986, see reg. 1

## B

### BRAKES

### Braking systems of certain vehicles first used on or after 1st April 1983

[<sup>F121</sup>15.—(1) Save as provided in paragraphs (2), (3) and (4), the braking system of every wheeled vehicle of a class specified in an item in column 2 of the Table which, in the case of a motor vehicle, is first used on or after 1st April 1983 or which, in the case of a trailer, is manufactured on or after 1st October 1982 shall comply with the construction, fitting and performance requirements specified in Annexes I, II and VII to Community Directive 79/489, and if relevant, Annexes III, IV, V, VI and VIII to that Directive in relation to the category of vehicles specified in that item in column 3.

Provided that it shall be lawful for any vehicle of such a class which, in the case of a motor vehicle, was first used before 1st April 1983 or which, in the case of a trailer, was manufactured before 1st October 1982 to comply with the said requirements instead of complying with regulations 16 and 17.

(1A) Save as provided in paragraphs (2),(3), (3A) and (5), the braking system of every wheeled vehicle of a class specified in an item in column 2 of the Table which, in the case of a motor vehicle, is first used on or after the relevant date or which, in the case of a trailer, is manufactured on or after the relevant date shall comply with the construction, fitting and performance requirements specified in Annexes I, II and VII to Community Directive 85/647, and if relevant, Annexes III, IV, V, VI, VIII, X, XI and XII to that Directive in relation to the category of vehicles specified in that item in column 3.

**Status:** Point in time view as at 31/03/2009.

**Status:** This revised version has been created from an electronic version contributed by Westlaw which was originally derived from the printed publication. **Read more** (See end of Document for details) **Changes to legislation:** There are currently no known outstanding effects for the The Road Vehicles (Construction and Use) Regulations 1986. (See end of Document for details)

Provided that it shall be lawful for any vehicle of such a class which, in the case of a motor vehicle, was first used before the relevant date or which, in the case of a trailer, was manufactured before the relevant date to comply with the said requirements instead of complying with paragraph (1) or with regulations 16 and 17.

(1B) In paragraph (1A), the relevant date in relation to a vehicle of a class specified in item 1 or 2 of the Table is 1st April 1990, in relation to a vehicle specified in item 4 of that Table is 1st April 1992, in relation to a vehicle in items 7, 8, 9 or 10 of that Table is 1st October 1988 and in relation to a vehicle of any other class is 1st April 1989.

(1C) Save as provided in paragraphs (2), (3), (3A) and (5A), the braking system of every wheeled vehicle of a class specified in an item in column 2 of the Table which, in the case of a motor vehicle, is first used on or after 1st April 1992 or which, in the case of a trailer, is manufactured on or after 1st October 1991 shall comply with the construction, fitting and performance requirements specified in Annexes I, II and VII to Community Directive 88/194, and if relevant, Annexes III, IV, V, VI, VIII, X, XI and XII to that Directive in relation to the category of vehicles specified in that item in column 3.

Provided that it shall be lawful for any vehicle of such a class which, in the case of a motor vehicle, was first used before 1st April 1992 or which, in the case of a trailer, was manufactured before 1st October 1991 to comply with the said requirements instead of complying with paragraph (1) or (1A) or with regulations 16 and 17.

(1D) Save as provided in paragraphs (2), (3), (3A) and (5A), the braking system of every wheeled vehicle of a class specified in an item in column 2 of the Table which, in the case of a motor vehicle, is first used on or after 1st April 1995 or which, in the case of a trailer, is manufactured on or after that date shall comply with the construction, fitting and performance requirements specified in Annexes I, II, and VII to Community Directive 91/422, and if relevant, Annexes III, IV, V, VI, VIII, X, XI and XII to that Directive in relation to the category of vehicles specified in that item in column 3.

Provided that it shall be lawful for any vehicle of such a class which, in the case of a motor vehicle, was first used before 1st April 1995 or which, in the case of a trailer, was manufactured before that date to comply with the said requirements instead of complying with paragraph (1), (1A) or (1C) or with regulations 16 and 17.

[<sup>F122</sup>(1E) Save as provided in paragraphs (2), (3), (3A), (5A) and (5B) the braking system of every wheeled vehicle of a class specified in an item in column 2 of the Table which, in the case of a motor vehicle, is first used on or after 1st May 2002 or which, in the case of a trailer, is manufactured on or after 1st May 2002 shall comply with the construction, fitting and performance requirements of Annexes I, II and VII to Community Directive 98/12/EC and if relevant, Annexes III, IV, V, VI, VIII, X, XI, XII, XIII and XIV to that Directive in relation to the category of vehicles specified in that item in column 3.

Provided that it shall be lawful for any vehicle of such a class which, in the case of a motor vehicle, was first used before 1st May 2002 or which, in the case of a trailer, was manufactured before 1st [<sup>F123</sup>May] 2002 to comply with the said requirements instead of complying with paragraphs (1), (1A), (1C) or (1D) or with regulations 16 and 17.]

- (2) The requirements specified in paragraphs (1), (1A), [<sup>F124</sup>(1C), (1D) and (1E)] do not apply to—
- (a) an agricultural trailer or agricultural trailed appliance that is not, in either case, drawn at a speed exceeding 20 mph;
  - (b) a locomotive;
  - (c) a motor tractor;
  - (d) an agricultural motor vehicle unless it is first used after 1st June 1986 and is driven at more than 20 mph;
  - (e) a vehicle which has a maximum speed not exceeding 25 km/h;

- (f) a works trailer;
  - (g) a works truck;
  - (h) a public works vehicle;
  - (i) a trailer designed and constructed, or adapted, to be drawn exclusively by a vehicle to which sub-paragraph (b), (c), (e), (g) or (h) of this paragraph applies;
  - [<sup>F125</sup>(j) a trailer falling within regulation 16(3)(b), (bb), (bc), (d), (e), (f) or (g);
  - (ja) a trailer which is manufactured before 1st January 1997 and has a maximum total design axle weight that does not exceed 750 kg; or]
  - (k) a vehicle manufactured by Leyland Vehicles Limited and known as the Atlantean Bus, if first used before 1st October 1984.
- (3) The requirements specified in paragraphs (1), (1A), [<sup>F126</sup>(1C), (1D) and (1E)] shall apply to the classes of vehicles specified in the Table so that—
- (a) in item 3, the testing requirement specified in paragraph 1.5.1 and 1.5.2 of Annex II to Community Directives 79/489, 85/647, [<sup>F127</sup>88/194, 91/422 and 98/12] shall apply to every vehicle specified in that item other than—
    - (i) a double-decked vehicle first used before 1st October 1983, or
    - (ii) a vehicle of a type in respect of which a member state of the European Economic Community has issued a type approval certificate in accordance with Community Directive 79/489, 85/647, [<sup>F128</sup>88/194, 91/422 or 98/12];
  - (b) in items 2 and 3—
    - (i) the requirements specified in paragraph 1.1.4.2 of Annex II to Community Directive 79/489, 85/647, [<sup>F129</sup>88/194, 91/422 and 98/12] shall not apply in relation to any vehicle first used before 1st April 1996;
    - (ii) those requirements shall not apply in relation to any relevant bus first used on or after that date;
    - (iii) sub-note (2) to paragraph 1.17.2 of Annex I to Community Directive 85/647, [<sup>F130</sup>88/194, 91/422 and 98/12] shall not apply in relation to any vehicle, and for the purposes of this sub-paragraph “relevant bus” means a bus that is not a coach;
  - (c) in items 1, 2, 3, 4, 5 and 6, in the case of vehicles constructed or adapted for use by physically handicapped drivers, the requirement in paragraph 2.1.2.1 of Annex I to Community Directive 79/489 that the driver must be able to achieve the braking action mentioned in that paragraph from his driving seat without removing his hands from the steering control shall be modified so as to require that the driver is able to achieve that action while continuing to steer the vehicle; and
  - (d) in items 1, 4, 5, 6, 7, 8, 9 and 10, the requirement specified in paragraph 1.1.4.2 of Annex II to Community Directive 79/489 shall not apply to a vehicle first used (in the case of a motor vehicle) or manufactured (in the case of a trailer) before the relevant date as defined in paragraph (1B) if either—
    - (i) following a test in respect of which the fee numbered 26024/26250 to 26257, prescribed in Schedule 1 to the Motor Vehicles (Type Approval and Approval Marks) (Fees) Regulations 1990, or the corresponding fee prescribed under any corresponding previous enactment is payable, a document is issued by the Secretary of State indicating that, at the date of manufacture of the vehicle, the type to which it belonged complied with the requirements specified in Annex 13 to ECE Regulation 13.03, 13.04, [<sup>F131</sup>13.05, 13.06, 13.07, 13.08 or 13.09]; or

**Status:** Point in time view as at 31/03/2009.

**Status:** This revised version has been created from an electronic version contributed by Westlaw which was originally derived from the printed publication. **Read more** (See end of Document for details) **Changes to legislation:** There are currently no known outstanding effects for the The Road Vehicles (Construction and Use) Regulations 1986. (See end of Document for details)

(ii) as a result of a notifiable alteration to the vehicle within the meaning of regulation 3 of the Plating and Testing Regulations, a fitment has been approved as complying with the requirements mentioned in sub-paragraph (i).

(3A) The requirements specified in paragraphs (1A), [F132(1C), (1D) and (1E)] shall apply to a road tanker subject to the exclusion of paragraph 4.3 of Annex X to Community Directive 85/647.

(3B) No motor vehicle to which [F133 paragraph (1D) or (1E)] applies and which is first used on or after 1st April 1996 shall be fitted with an integrated retarder unless either—

(a) the motor vehicle is fitted with an anti-lock device which acts on the retarder and which complies with the requirements specified in Annex X to Community Directive 91/422 [F134 or Community Directive 98/12]; or

(b) the retarder is fitted with a cut-out device which allows the combined control to apply the service braking system alone and which can be operated by the driver from the driving seat; and expressions (other than the word “vehicle”) used in this paragraph which are also used in Annex I to Community Directive 85/647 shall, for the purposes of this paragraph, have the same meanings as in that Annex save that “retarder” shall not in any circumstances include a regenerative braking system.

(4) Instead of complying with paragraph (1) of this regulation, a vehicle to which this regulation applies may comply with ECE Regulation 13.03, 13.04, [F135 13.05, 13.06, 13.07, 13.08 or 13.09].

(5) Instead of complying with paragraph (1A) of this regulation, a vehicle to which this regulation applies may comply with ECE Regulation [F136 13.05, 13.06, 13.07, 13.08 or 13.09].

(5A) Instead of complying with paragraph (1C) or (1D) of this regulation, a vehicle to which this regulation applies may comply—

(a) in the case of a trailer manufactured before 1st April 1992, with ECE Regulation 13.05 or 13.06; or

(b) in the case of any vehicle not falling within sub-paragraph (a), with ECE Regulation 13.06 [F137 13.07, 13.08 or 13.09].

[F138(5B) Instead of complying with paragraph (1E) of this regulation, a vehicle to which this regulation applies may comply with ECE Regulation 13.09.]

(6) In paragraph (3A), the expression “road tanker” means any vehicle or trailer which carries liquid fuel in a tank forming part of the vehicle or trailer other than that containing the fuel which is used to propel the vehicle, and also includes any tank with a capacity exceeding 3m<sup>3</sup> carried on a vehicle.

(7) In this regulation, and in relation to the application to any vehicle of any provision of Community Directive 85/647, [F139 88/194, 91/422 or 98/12], the definitions of “semi-trailer”, “full trailer” and “centre-axle trailer” set out in that Directive shall apply and the meaning of “semi-trailer” in column 2 of the Table in regulation 3(2) shall not apply.

[F140(8) For the purposes of the preceding provisions of this regulation the date on which a trailer was manufactured shall be taken to be the date on which its manufacture was completed except that, in the case of a trailer whose manufacture has been completed for more than 8 years and which has been the subject of a notifiable alteration under regulation 30 of the Goods Vehicles (Plating and Testing) Regulations 1988, it shall be taken to be the date on which the notifiable alteration was completed.

(9) A trailer, whose manufacture has been completed for more than eight years and which has been the subject of a notifiable alteration under regulation 30 of the Goods Vehicles (Plating and Testing) Regulations 1988, shall comply with all requirements of Community Directives relating to braking systems which applied to the trailer at the date when the notifiable alteration was completed.]



**TABLE**

(regulation 15(1))

1 <i>Item</i>	2 <i>Class of Vehicle</i>	3 <i>Vehicle Category in the Community Directive</i>
1	Passenger vehicles and dual-purpose vehicles which have 3 or more wheels except— (a) dual-purpose vehicles constructed or adapted to carry not more than 2 passengers exclusive of the driver; (b) motor cycles with sidecar attached; (c) vehicles with three wheels, an unladen weight not exceeding 410kg, a maximum design speed not exceeding 50 km/h and an engine capacity not exceeding 50 cc; (d) buses.	M1
2	Buses having a maximum gross weight which does not exceed 5000 kg.	M2
3	Buses having a maximum gross weight which exceeds 5000 kg.	M3
4	Dual-purpose vehicles not within item 1; and goods vehicles, having a maximum gross weight which does not exceed 3500 kg, and not being motor cycles with a sidecar attached.  Goods vehicles with a maximum gross weight which—	N1
5	exceeds 3500 kg but does not exceed 12,000 kg;	N2
6	exceeds 12,000 kg.  Trailers with a maximum total design axle weight which—	N3
7	does not exceed 750 kg;	01

**Status:** Point in time view as at 31/03/2009.

**Status:** This revised version has been created from an electronic version contributed by Westlaw which was originally derived from the printed publication. **Read more** (See end of Document for details)**Changes to legislation:** There are currently no known outstanding effects for the The Road Vehicles (Construction and Use) Regulations 1986. (See end of Document for details)

1 <i>Item</i>	2 <i>Class of Vehicle</i>	3 <i>Vehicle Category in the Community Directive</i>
8	exceeds 750 kg but does not exceed 3500 kg;	02
9	exceeds 3500 kg but does not exceed 10,000 kg;	03
10	exceeds 10,000 kg.	04]

### Textual Amendments

- F121** Reg. 15 set out as amended by [The Road Vehicles \(Construction and Use\) \(Amendment\) Regulations 1995 \(S.I. 1995/551\)](#), reg. 3 and previous regulations with minor adjustments to the punctuation and spelling, see S.I. 1995/551, reg. 3(13), Sch.
- F122** Reg. 15(1E) inserted (1.5.2002) by [The Road Vehicles \(Construction and Use\) \(Amendment\) \(No. 4\) Regulations 2001 \(S.I. 2001/3208\)](#), regs. 1(2), **5(2)**
- F123** Word in reg. 15(1E) substituted (1.7.2002) by [The Road Vehicles \(Construction and Use\) \(Amendment\) \(No. 2\) Regulations 2002 \(S.I. 2002/1474\)](#), regs. 1, **5**
- F124** Words in reg. 15(2) substituted (1.5.2002) by [The Road Vehicles \(Construction and Use\) \(Amendment\) \(No. 4\) Regulations 2001 \(S.I. 2001/3208\)](#), regs. 1(2), **5(3)**
- F125** Reg. 15(2)(j)(ja) substituted for reg. 15(2)(j) (1.1.1997) by [The Road Vehicles \(Construction and Use\) \(Amendment\) \(No. 7\) Regulations 1996 \(S.I. 1996/3033\)](#), regs. 1, **3**
- F126** Words in reg. 15(3) substituted (1.5.2002) by [The Road Vehicles \(Construction and Use\) \(Amendment\) \(No. 4\) Regulations 2001 \(S.I. 2001/3208\)](#), regs. 1(2), **5(4)**
- F127** Words in reg. 15(3)(a) substituted (1.5.2002) by [The Road Vehicles \(Construction and Use\) \(Amendment\) \(No. 4\) Regulations 2001 \(S.I. 2001/3208\)](#), regs. 1(2), **5(5)**
- F128** Words in reg. 15(3)(a)(ii) substituted (1.5.2002) by [The Road Vehicles \(Construction and Use\) \(Amendment\) \(No. 4\) Regulations 2001 \(S.I. 2001/3208\)](#), regs. 1(2), **5(6)**
- F129** Words in reg. 15(3)(b)(i) substituted (1.5.2002) by [The Road Vehicles \(Construction and Use\) \(Amendment\) \(No. 4\) Regulations 2001 \(S.I. 2001/3208\)](#), regs. 1(2), **5(7)**
- F130** Words in reg. 15(3)(b)(iii) substituted (1.5.2002) by [The Road Vehicles \(Construction and Use\) \(Amendment\) \(No. 4\) Regulations 2001 \(S.I. 2001/3208\)](#), regs. 1(2), **5(8)**
- F131** Words in reg. 15(3)(d)(i) substituted (1.5.2002) by [The Road Vehicles \(Construction and Use\) \(Amendment\) \(No. 4\) Regulations 2001 \(S.I. 2001/3208\)](#), regs. 1(2), **5(9)**
- F132** Words in reg. 15(3A) substituted (1.5.2002) by [The Road Vehicles \(Construction and Use\) \(Amendment\) \(No. 4\) Regulations 2001 \(S.I. 2001/3208\)](#), regs. 1(2), **5(10)**
- F133** Words in reg. 15(3B) substituted (1.5.2002) by [The Road Vehicles \(Construction and Use\) \(Amendment\) \(No. 4\) Regulations 2001 \(S.I. 2001/3208\)](#), regs. 1(2), **5(11)**
- F134** Words in reg. 15(3B)(a) inserted (1.5.2002) by [The Road Vehicles \(Construction and Use\) \(Amendment\) \(No. 4\) Regulations 2001 \(S.I. 2001/3208\)](#), regs. 1(2), **5(12)**
- F135** Words in reg. 15(4) substituted (1.5.2002) by [The Road Vehicles \(Construction and Use\) \(Amendment\) \(No. 4\) Regulations 2001 \(S.I. 2001/3208\)](#), regs. 1(2), **5(13)**
- F136** Words in reg. 15(5) substituted (1.5.2002) by [The Road Vehicles \(Construction and Use\) \(Amendment\) \(No. 4\) Regulations 2001 \(S.I. 2001/3208\)](#), regs. 1(2), **5(14)**
- F137** Words in reg. 15(5A)(b) inserted (1.5.2002) by [The Road Vehicles \(Construction and Use\) \(Amendment\) \(No. 4\) Regulations 2001 \(S.I. 2001/3208\)](#), regs. 1(2), **5(15)**
- F138** Reg. 15(5B) inserted (1.5.2002) by [The Road Vehicles \(Construction and Use\) \(Amendment\) \(No. 4\) Regulations 2001 \(S.I. 2001/3208\)](#), regs. 1(2), **5(16)**
- F139** Words in reg. 15(7) substituted (1.5.2002) by [The Road Vehicles \(Construction and Use\) \(Amendment\) \(No. 4\) Regulations 2001 \(S.I. 2001/3208\)](#), regs. 1(2), **5(17)**

**Status:** This revised version has been created from an electronic version contributed by Westlaw which was originally derived from the printed publication. **Read more** (See end of Document for details)**Changes to legislation:** There are currently no known outstanding effects for the The Road Vehicles (Construction and Use) Regulations 1986. (See end of Document for details)

**F140** Reg. 15(8)(9) inserted (1.5.2002) by The Road Vehicles (Construction and Use) (Amendment) (No. 4) Regulations 2001 (S.I. 2001/3208), regs. 1(2), **5(18)**

**Commencement Information**

**I13** Reg. 15 in force at 11.8.1986, see **reg. 1**

**Braking systems of vehicles to which regulation 15 does not apply**

**16.**—(1) Save as provided in paragraphs (2) and (3), this regulation applies to every vehicle to which regulation 15 does not apply.

[<sup>F141</sup>(2) Paragraph (4) of this regulation does not apply to a vehicle which complies with regulation 15 by virtue of the proviso to regulation 15(1), (1A), (1C), (1D) or (1E), or which complies with Community Directive 79/489, 85/647, 88/194, 91/422 or 98/12 or ECE Regulation 13.03, 13.04, 13.05, 13.06, 13.07, 13.08 or 13.09.]

(3) This regulation does not apply to the following vehicles, except in the case of a vehicle referred to in (a) insofar as the regulation concerns parking brakes (requirements 16 to 18 in Schedule 3)—

- (a) a locomotive first used before 2nd January 1933, propelled by steam, and with an engine which is capable of being reversed;
- [<sup>F142</sup>(b) a trailer which is designed for use and used for street cleansing and does not carry any load other than its necessary gear and equipment;
- (ba) a trailer which has a maximum total design axle weight that does not exceed 750 kg;
- (bb) a trailer which—
  - (i) is an agricultural trailer manufactured before 1st July 1947;
  - (ii) is being drawn by a motor tractor or an agricultural motor vehicle at a speed not exceeding 10 mph;
  - (iii) has a laden weight not exceeding 4070 kg; and
  - (iv) is the only trailer being drawn;
- (bc) a trailer which is being drawn by a motor cycle in accordance with regulation 84;]
- (c) an agricultural trailed appliance;
- (d) an agricultural trailed appliance conveyor;
- (e) a broken down vehicle;
- (f) before 1st October 1986—
  - (i) a trailer with an unladen weight not exceeding 102 kg which was manufactured before 1st October 1982; and
  - (ii) a gritting trailer; or
- (g) on or after 1st October 1986, a gritting trailer with a maximum gross weight not exceeding 2000 kg.

(4) Save as provided in paragraph (7), a vehicle of a class specified in an item in column 2 of the Table shall comply with the requirements shown in column 3 in that item, subject to any exemptions or modifications shown in column 4 in that item, reference to numbers in column 3 being references to the requirements so numbered in Schedule 3.

**TABLE**

(regulation 16(4))

**Status:** Point in time view as at 31/03/2009.

**Status:** This revised version has been created from an electronic version contributed by Westlaw which was originally derived from the printed publication. **Read more** (See end of Document for details)**Changes to legislation:** There are currently no known outstanding effects for the The Road Vehicles (Construction and Use) Regulations 1986. (See end of Document for details)

<i>1</i> <i>Item</i>	<i>2</i> <i>Class of vehicle</i>	<i>3</i> <i>Requirements in Schedule 3</i>	<i>4</i> <i>Exemptions or modifications</i>
<i>Motor cars</i>			
1	First used before 1st January 1915.	3, 6, 7, 13, 16	Requirements 13 and 16 do not apply to a motor car with less than 4 wheels.
2	First used on or after 1st January 1915 but before 1st April 1938.	1, 4, 6, 7, 9, 16	A works truck within items 1 to 11 is not subject to requirements 1, 2, 3 or 4 if it is equipped with one braking system with one means of operation.
3	First used on or after 1st April 1938 and being either a track-laying vehicle or a vehicle first used before 1st January 1968.	1, 4, 6, 7, 8, 9, 16	
4	Wheeled vehicles first used on or after 1st January 1968.	1, 4, 6, 7, 8, 9, [F14315,] 18	
<i>Heavy motor cars</i>			
5	First used before 15th August 1928.	1, 6, 16	
6	First used on or after 15th August 1928 but before 1st April 1938.	1, 4, 6, 7, 8, 16	
7	First used on or after 1st April 1938 and being either a track-laying vehicle or a vehicle first used before 1st January 1968.	1, 4, 6, 7, 8, 9, 16	
8	Wheeled vehicles first used on or after 1st January 1968.	1, 4, 6, 7, 8, 9, [F14315,] 18	
<i>Motor cycles</i>			
9	First used before 1st January 1927.	3, and, in the case of three-wheeled vehicles, 16	
10	First used on or after 1st January 1927 but before 1st January 1968.	2, 7, and, in the case of three-wheeled vehicles, 16	
11	First used on or after 1st January 1968 and not being a motor cycle to which paragraph (5) applies.	2, 7, and, in the case of three-wheeled vehicles, 18	
<i>Locomotives</i>			

**Status:** This revised version has been created from an electronic version contributed by Westlaw which was originally derived from the printed publication. **Read more** (See end of Document for details)**Changes to legislation:** There are currently no known outstanding effects for the The Road Vehicles (Construction and Use) Regulations 1986. (See end of Document for details)

<i>1</i> <i>Item</i>	<i>2</i> <i>Class of vehicle</i>	<i>3</i> <i>Requirements in Schedule 3</i>	<i>4</i> <i>Exemptions or modifications</i>
12	Wheeled vehicles first used before 1st June 1955.	3, 6, 12, 16	
13	Wheeled vehicles first used on or after 1st June 1955 but before 1st January 1968.	3, 4, 6, 7, 8, 9, 18	
14	Wheeled vehicles first used on or after 1st January 1968.	3, 4, 6, 7, 8, 9, 18	
15	Track-laying vehicles. <i>Motor tractors</i>	3, 6, 16	
16	Wheeled vehicles first used before 14th January 1931 and track-laying vehicles first used before 1st April 1938.	3, 4, 6, 7, 16	Industrial tractors within items 16 to 19 are subject to requirement 5 instead of requirement 4.
17	Wheeled vehicles first used on or after 14th January 1931 but before 1st April 1938.	3, 4, 6, 7, 9, 16	
18	Wheeled vehicles first used on or after 1st April 1938 but before 1st January 1968.	3, 4, 6, 7, 8, 9, 16	
19	Wheeled vehicles first used on or after 1st January 1968.	3, 4, 6, 7, 8, 9, 18	
20	Track-laying vehicles first used on or after 1st April 1938. <i>Wheeled agricultural motor vehicles not driven at more than 20 mph</i>	3, 4, 6, 7, 8, 16	
21	First used before 1st January 1968.	3, 4, 6, 7, 8, 16	
22	First used on or after 1st January 1968 but before 9th February 1980.	3, 4, 6, 7, 8, 18	
23	First used on or after 9th February 1980. <i>Invalid carriages</i>	3, 5, 6, 7, 8, 18	
24	Whenever first used. <i>Trailers</i>	3, 13	
25	Manufactured before 1st April 1938.	3, 10, 14, 17	
26	Manufactured on or after 1st April 1938 and being either a track-laying vehicle, an agricultural	3, 8, 10, 14, 17	Agricultural trailers are not subject to requirement 8.

**Status:** Point in time view as at 31/03/2009.

**Status:** This revised version has been created from an electronic version contributed by Westlaw which was originally derived from the printed publication. **Read more** (See end of Document for details)**Changes to legislation:** There are currently no known outstanding effects for the The Road Vehicles (Construction and Use) Regulations 1986. (See end of Document for details)

<i>1</i> <i>Item</i>	<i>2</i> <i>Class of vehicle</i>	<i>3</i> <i>Requirements in Schedule 3</i>	<i>4</i> <i>Exemptions or modifications</i>
27	trailer or a vehicle manufactured before 1st January 1968. Wheeled vehicles manufactured on or after 1st January 1968, not being an agricultural trailer.	3, 4, 8, 11, 15, 18	Trailers equipped with brakes which come into operation on the overrun of the vehicle are not subject to requirement 15.

Provided that wheeled agricultural motor vehicles not driven at more than 20 mph are excluded from all items other than items 21 to 23.

[<sup>F144</sup>(5) Subject to paragraphs (5B) and (6), the braking system of a motor cycle to which this regulation applies and which is—

- (a) of a class specified in an item in column 2 of the Table below; and
- (b) first used on or after 1st April 1987 and before 22nd May 1995;

shall comply with ECE Regulation 13.05, 78 or 78.01 [<sup>F145</sup>or Community Directive 93/14] in relation to the category of vehicles specified in that item in column 3.

(5A) Subject to paragraph (6), the braking system of a motor cycle to which this regulation applies and which is—

- (a) of a class specified in an item in column 2 of the Table below; and
- (b) first used on or after 22nd May 1995;

shall comply with ECE Regulation 78.01 [<sup>F146</sup>or Community Directive 93/14] in relation to the category of vehicles specified in that item in column 3.

#### TABLE

(Regulation 16(5) and (5A))

<i>1</i> <i>Item</i>	<i>2</i> <i>Class of Vehicle</i>	<i>3</i> <i>[<sup>F147</sup>Vehicle Category in ECE Regulations or Community Directive 93/14 (as the case may be)]</i>
1	Vehicles (without a sidecar attached) with two wheels, an engine capacity not exceeding 50 cc and a maximum design speed not exceeding 50 km/h.	L1
2	Vehicles with three wheels (including two-wheeled vehicles with a sidecar attached) and with an engine capacity not exceeding 50 cc	L2

**Status:** This revised version has been created from an electronic version contributed by Westlaw which was originally derived from the printed publication. **Read more** (See end of Document for details)**Changes to legislation:** There are currently no known outstanding effects for the The Road Vehicles (Construction and Use) Regulations 1986. (See end of Document for details)

1 Item	2 Class of Vehicle	3 [ <sup>F147</sup> Vehicle Category in ECE Regulations or Community Directive 93/14 (as the case may be)]
3	and a maximum design speed not exceeding 50 km/h. Vehicles with two wheels (without a sidecar attached) and with— (a) an engine capacity exceeding 50 cc, or (b) a maximum design speed exceeding 50 km/h.	L3
4	Vehicles with two wheels, a sidecar attached and— (a) an engine capacity exceeding 50 cc, or (b) a maximum design speed exceeding 50 km/h.	L4
[ <sup>F148</sup> 5	Vehicles with three wheels (excluding two-wheeled vehicles with a sidecar attached) and with— (a) an engine capacity exceeding 50cc, or (b) a maximum design speed exceeding 50km/h.	L5 ]]

[<sup>F149</sup>[<sup>F150</sup>(5B)] In relation to a motor cycle with two wheels manufactured by Piaggio Veicoli Europei Societa per Azione and known as the Cosa 125, the Cosa 125E, the Cosa L125, the Cosa LX125, the Cosa 200, the Cosa 200E, the Cosa L200 or the Cosa LX200, paragraph (5) shall have effect as if ECE Regulation 13.05 were modified by—

- (a) the omission of paragraph 4.4 (approval marks), and
- (b) in paragraph 5.3.1.1, (independent braking devices and controls), the omission of the word “independent” in the first place where it appears,

but this paragraph shall not apply to a motor cycle first used on or after 1st July 1991.]

(6) Paragraph (5) does not apply to a works truck or to a vehicle constructed or assembled by a person not ordinarily engaged in the business of manufacturing vehicles of that description.

[<sup>F151</sup>(6A) Paragraph (5A) does not apply to—

- (a) a vehicle with a maximum speed not exceeding 25 km/h; or
- (b) a vehicle fitted for an invalid driver.]

(7) Instead of complying with the provisions of paragraph (4) of this Regulation an agricultural motor vehicle may comply with Community Directive 76/432 [<sup>F152</sup>or 96/63].

**Status:** Point in time view as at 31/03/2009.

**Status:** This revised version has been created from an electronic version contributed by Westlaw which was originally derived from the printed publication. **Read more** (See end of Document for details)**Changes to legislation:** There are currently no known outstanding effects for the The Road Vehicles (Construction and Use) Regulations 1986. (See end of Document for details)

### Textual Amendments

- F141** Reg. 16(2) substituted (1.5.2002) by The Road Vehicles (Construction and Use) (Amendment) (No. 4) Regulations 2001 (S.I. 2001/3208), regs. 1(2), **6(2)**
- F142** Reg. 16(3)(b)-(bc) substituted for reg. 16(3)(b) (1.1.1997) by The Road Vehicles (Construction and Use) (Amendment) (No. 7) Regulations 1996 (S.I. 1996/3033), regs. 1, **4(2)**
- F143** Word in reg. 16 Table inserted (2.11.1990) by The Road Vehicles (Construction and Use) (Amendment) (No. 4) Regulations 1990 (S.I. 1990/1981), regs. 1, **5(3)**
- F144** Reg. 16(5)(5A) and Table substituted for reg. 16(5) (1.4.1992) by The Road Vehicles (Construction and Use) (Amendment) Regulations 1992 (S.I. 1992/352), regs. 1, **4(3)**
- F145** Words in reg. 16(5) inserted (1.1.1997) by The Road Vehicles (Construction and Use) (Amendment) (No. 7) Regulations 1996 (S.I. 1996/3033), regs. 1, **4(3)**
- F146** Words in reg. 16(5A) inserted (1.1.1997) by The Road Vehicles (Construction and Use) (Amendment) (No. 7) Regulations 1996 (S.I. 1996/3033), regs. 1, **4(3)**
- F147** Words in reg. 16(5A) Table substituted (1.1.1997) by The Road Vehicles (Construction and Use) (Amendment) (No. 7) Regulations 1996 (S.I. 1996/3033), regs. 1, **4(4)**
- F148** Words in reg. 16(5A) Table inserted (1.5.2002) by The Road Vehicles (Construction and Use) (Amendment) (No. 4) Regulations 2001 (S.I. 2001/3208), regs. 1(2), **6(3)**
- F149** Reg. 16(5A) inserted (2.11.1990) by The Road Vehicles (Construction and Use) (Amendment) (No. 4) Regulations 1990 (S.I. 1990/1981), regs. 1, **5(5)**
- F150** Reg. 16(5A) renumbered as reg. 16(5B) (1.4.1992) by The Road Vehicles (Construction and Use) (Amendment) Regulations 1992 (S.I. 1992/352), regs. 1, **4(4)**
- F151** Reg. 16(6A) inserted (1.4.1995) by The Road Vehicles (Construction and Use) (Amendment) Regulations 1995 (S.I. 1995/551), regs. 1, **4(3)**
- F152** Words in reg. 16(7) inserted (1.11.1998) by The Road Vehicles (Construction and Use) (Amendment) (No. 6) Regulations 1998 (S.I. 1998/2429), regs. 1, **3**

### Commencement Information

- I14** Reg. 16 in force at 11.8.1986, see **reg. 1**

### Vacuum or pressure brake warning devices

17.—(1) Save as provided in paragraph (2), every motor vehicle which is equipped with a braking system which embodies a vacuum or pressure reservoir or reservoirs shall be equipped with a device so placed as to be readily visible to the driver of the vehicle and which is capable of indicating any impending failure of, or deficiency in, the vacuum or pressure system.

(2) The requirement specified in paragraph (1) does not apply in respect of—

- [<sup>F153</sup>(a) a vehicle to which paragraph (1), (1A), (1C), (1D) or (1E) of regulation 15 applies, or which complies with the requirements of that regulation, of Community Directives 79/489, 85/647, 88/194, 91/422 or 98/12 or of ECE Regulation 13.03, 13.04, 13.05, 13.06, 13.07, 13.08 or 13.09;]
- (b) an agricultural motor vehicle which complies with Community Directive 76/432 [<sup>F154</sup>or 96/63];
- (c) a vehicle with an unladen weight not exceeding 3050 kg propelled by an internal combustion engine, if the vacuum in the reservoir or reservoirs is derived directly from the induction system of the engine, and if, in the event of a failure of, or deficiency in, the vacuum system, the brakes of that braking system are sufficient under the most adverse conditions to bring the vehicle to rest within a reasonable distance; or
- (d) a vehicle first used before 1st October 1937.



**Status:** This revised version has been created from an electronic version contributed by Westlaw which was originally derived from the printed publication. **Read more** (See end of Document for details)**Changes to legislation:** There are currently no known outstanding effects for the The Road Vehicles (Construction and Use) Regulations 1986. (See end of Document for details)

### Textual Amendments

- F153** Reg. 17(2)(a) substituted (1.5.2002) by [The Road Vehicles \(Construction and Use\) \(Amendment\) \(No. 4\) Regulations 2001](#) (S.I. 2001/3208), regs. 1(2), **7(2)**
- F154** Words in reg. 17(2)(b) inserted (1.11.1998) by [The Road Vehicles \(Construction and Use\) \(Amendment\) \(No. 6\) Regulations 1998](#) (S.I. 1998/2429), regs. 1, **4**

### Commencement Information

- I15** [Reg. 17](#) in force at 11.8.1986, see [reg. 1](#)

## [<sup>F155</sup>Couplings on trailer pneumatic braking systems

**17A.**—(1) In this regulation—

[<sup>F156</sup>“BS coupling” means a coupling which—

- (a) is of the type, shown in figure 1, 4 or 5 of the British Standard specification BS AU 138a: 1980 or figure 1, 2 or 3 of the British Standard specification BS AU 138b: 2000; and
- (b) complies with the dimensions shown in figure 1, 4 or 5 of the British Standard specification BS AU 138a: 1980 or figure 1, 2 or 3 of the British Standard specification BS AU 138b:2000;]

“the British Standard specification” means the British Standard specification for dimensions of ‘contact’ type couplings for air pressure braking systems on trailers and semi-trailers and their towing vehicles, and the arrangements of these couplings on articulated and drawbar combinations, published by the British Standards Institution under reference number BS AU 138a: 1980 [<sup>F157</sup>or BS AU 138b: 2000];

“coupling”, “emergency line”, “secondary line” and “service line” have the same meanings as in the British Standard specification;

“EEA Agreement” means the Agreement on the European Economic Area signed at Oporto on the 2nd May 1992 as adjusted by the Protocol signed at Brussels on 17th March 1993; and

“EEA State” means a state which is a Contracting Party to the EEA Agreement.

(2) For the purposes of this regulation, a relevant coupling is a coupling that is physically capable of being connected to a BS coupling.

(3) Subject to paragraphs (6) and (7), no service line comprised in a pneumatic braking system fitted to a trailer shall be equipped with a relevant coupling unless that coupling—

- [<sup>F158</sup>(a) is of the type shown in figure 2 of the British Standard specification BS AU 138a:1980 or figure 4 of the British Standard specification BS AU 138b:2000;]
- (b) complies with the dimensions shown in that figure; and
- (c) complies with paragraph 3.4.3 of that specification (except so far as it requires it to be of a type shown in that figure).

(4) Subject to paragraphs (6), (7) and (8) no emergency line comprised in a pneumatic braking system fitted to a trailer shall be equipped with a relevant coupling unless that coupling—

- [<sup>F159</sup>(a) is of the type shown in figure 3 of the British Standard specification BS AU 138a:1980 or figure 5 of the British Standard specification 138b:2000;] and
- (b) complies with the dimensions shown in that figure.

(5) Subject to paragraphs (6), (7) and (8) no secondary line comprised in a pneumatic braking system fitted to a trailer shall be equipped with a relevant coupling unless that coupling—

**Status:** Point in time view as at 31/03/2009.

**Status:** This revised version has been created from an electronic version contributed by Westlaw which was originally derived from the printed publication. **Read more** (See end of Document for details)**Changes to legislation:** There are currently no known outstanding effects for the The Road Vehicles (Construction and Use) Regulations 1986. (See end of Document for details)

[<sup>F160</sup>(a) is of the type shown in figure 6 of the British Standard specification BS AU 138a:1980 or figure 6 of the British Standard specification BS AU 138b:2000;] and

(b) complies with the dimensions shown in that figure.

(6) For the purposes of paragraphs (3), (4) and (5), a reference to the dimensions shown in a figure in the British Standard specification does not include any dimension marked “M22×1.5”.

[<sup>F161</sup>(7) Paragraph (3) does not prevent a line being equipped with a relevant coupling which fulfils the requirements of—

- (a) a standard or code of practice of a national standards body or equivalent body of any EEA State;
- (b) any international standard recognised for use as a standard by any EEA State; or
- (c) a technical specification or code of practice which, whether mandatory or not, is recognised for use as a standard by a public authority of any EEA State,

where the standard, code of practice, international standard or technical specification provides, in relation to couplings, a level of safety and compatibility with BS couplings of the type shown in figure 1 of the British Standard specification BS AU 138a:1980 or figure 1 of the British Standard specification BS AU 138b:2000 equivalent to that provided by those specifications as modified in accordance with paragraph (6).]

[<sup>F162</sup>(8) Paragraph (7) shall have effect—

- (a) in relation to paragraph (4), as if for the words “paragraph (3)” there were substituted the words “paragraph (4)” and for the words “figure 1” in the first and second places in which they occur there were substituted the words “figure 4” and “figure 2” respectively; and
- (b) in relation to paragraph (5), as if for the words “paragraph (3)” there were substituted the words “paragraph (5)” and for the words “figure 1” in the first and second places in which they occur there were substituted the words “figure 5” and “figure 3” respectively.]]

#### Textual Amendments

- F155** Reg. 17A inserted (1.1.1997) by The Road Vehicles (Construction and Use) (Amendment) (No. 7) Regulations 1996 (S.I. 1996/3033), regs. 1, **5**
- F156** Words in reg. 17A(1) substituted (16.10.2001) by The Road Vehicles (Construction and Use) (Amendment) (No. 4) Regulations 2001 (S.I. 2001/3208), regs. 1(2), **8(2)**
- F157** Words in reg. 17A(1) inserted (16.10.2001) by The Road Vehicles (Construction and Use) (Amendment) (No. 4) Regulations 2001 (S.I. 2001/3208), regs. 1(2), **8(3)**
- F158** Reg. 17A(3)(a) substituted (16.10.2001) by The Road Vehicles (Construction and Use) (Amendment) (No. 4) Regulations 2001 (S.I. 2001/3208), regs. 1(2), **8(4)**
- F159** Reg. 17A(4)(a) substituted (16.10.2001) by The Road Vehicles (Construction and Use) (Amendment) (No. 4) Regulations 2001 (S.I. 2001/3208), regs. 1(2), **8(5)**
- F160** Reg. 17A(5)(a) substituted (16.10.2001) by The Road Vehicles (Construction and Use) (Amendment) (No. 4) Regulations 2001 (S.I. 2001/3208), regs. 1(2), **8(6)**
- F161** Reg. 17A(7) substituted (16.10.2001) by The Road Vehicles (Construction and Use) (Amendment) (No. 4) Regulations 2001 (S.I. 2001/3208), regs. 1(2), **8(7)**
- F162** Reg. 17A(8) substituted (16.10.2001) by The Road Vehicles (Construction and Use) (Amendment) (No. 4) Regulations 2001 (S.I. 2001/3208), regs. 1(2), **8(8)**

#### Maintenance and efficiency of brakes

**18.**—(1) Every part of every braking system and of the means of operation thereof fitted to a vehicle shall be maintained in good and efficient working order and be properly adjusted.

**Status:** This revised version has been created from an electronic version contributed by Westlaw which was originally derived from the printed publication. **Read more** (See end of Document for details)**Changes to legislation:** There are currently no known outstanding effects for the The Road Vehicles (Construction and Use) Regulations 1986. (See end of Document for details)

<sup>F163</sup>(1A) Without prejudice to paragraph (3), where a vehicle is fitted with an anti-lock braking system (“the ABS”), then while the condition specified in paragraph (1B) is fulfilled, any fault in the ABS shall be disregarded for the purposes of paragraph (1).

(1B) The condition is fulfilled while the vehicle is completing a journey at the beginning of which the ABS was operating correctly or is being driven to a place where the ABS is to undergo repairs.]

<sup>F164</sup>(1C) Where a goods vehicle of category N<sub>2</sub> or N<sub>3</sub> is being used to tow a trailer of category O<sub>3</sub> or O<sub>4</sub> and both vehicles are fitted with an ISO 7638 connector to provide a dedicated power supply to the ABS, then these connectors shall be used regardless of any alternative method available on the vehicles to provide such power.]

(2) Paragraph (3) applies to every wheeled motor vehicle except—

- (a) an agricultural motor vehicle which is not driven at more than 20 mph;
- (b) a works truck; <sup>F165</sup>...
- (c) a pedestrian-controlled vehicle; <sup>F166</sup>and
- (d) an industrial tractor.]

(3) Every vehicle to which this paragraph applies and which is of a class specified in an item in column 2 of Table I shall, subject to any exemption shown for that item in column 4, be so maintained that—

- (a) its service braking system has a total braking efficiency not less than that shown in column 3(a) for that item; and
- (b) if the vehicle is a heavy motor car, a motor car first used on or after 1st January 1915 or a motor-cycle first used on or after 1st January 1927, its secondary braking system has a total braking efficiency not less than that shown in column 3(b) for those items.

Provided that a reference in Table I to a trailer is a reference to a trailer required by regulation 15 or 16 to be equipped with brakes.

**TABLE I**

(regulation 18(3))

<i>I</i> <i>Item</i>	<i>2</i> <i>Class of vehicle</i>	<i>3</i> <i>Efficiencies (%)</i> <i>(a) (b)</i>	<i>4</i> <i>Exemptions</i>
1	A vehicle to which regulation 15 applies or which complies in all respects other than its braking efficiency with the requirements of that regulation or with <sup>F167</sup> Community Directives 79/489, 85/647, 88/194, 91/422 or 98/12 or with ECE Regulation 13.03, 13.04, 13.05, 13.06, 13.07, 13.08 or 13.09]—		A motor cycle.
	(a) when not drawing a trailer;	50 25	
	(b) when drawing a trailer	45 25	
2	A vehicle, not included in item 1 and not being a motor cycle, which		

**Status:** Point in time view as at 31/03/2009.

**Status:** This revised version has been created from an electronic version contributed by Westlaw which was originally derived from the printed publication. **Read more** (See end of Document for details)**Changes to legislation:** There are currently no known outstanding effects for the The Road Vehicles (Construction and Use) Regulations 1986. (See end of Document for details)

1 Item	2 Class of vehicle	3 Efficiencies (%) (a) (b)	4 Exemptions
	is first used on or after 1st January 1968—		
	(a) when not drawing a trailer;	50 25	
	(b) when not drawing a trailer manufactured on or after 1st January 1968;	50 25	
	(c) when drawing a trailer manufactured before 1st January 1968	40 15	
3	Goods vehicles [ <sup>F168</sup> and buses (in each case)] first used on or after 15th August 1928 but before 1st January 1968 having an unladen weight exceeding 1525 kg being—		
	(a) rigid vehicles with 2 axles not constructed to form part of an articulated vehicle—		
	(i) when not drawing a trailer	45 20	
	(ii) when drawing a trailer	40 15	
	(b) other vehicles, including vehicles constructed to form part of an articulated vehicle, whether or not drawing a trailer	40 15	
4	Vehicles not included in items 1 to 3—		(a) a bus;
	(a) having at least one means of operation applying to at least 4 wheels;	50 25	(b) an articulated vehicle;
	(b) having 3 wheels and at least one means of operation applying to all 3 wheels and not being a motor cycle with sidecar attached—		(c) a vehicle constructed or adapted to form part of an articulated vehicle;
	(i) when not drawing a trailer	40 25	(d) a heavy motor car which is a goods vehicle first used before 15th August 1928.
	(ii) in the case of a motor cycle when drawing a trailer	40 25	
	(c) other		
	(i) when not drawing a trailer	30 25	

1 <i>Item</i>	2 <i>Class of vehicle</i>	3 <i>Efficiencies (%)</i> <i>(a) (b)</i>	4 <i>Exemptions</i>
	(ii) in the case of a motor cycle when drawing a trailer.	30 25	

(4) A goods vehicle shall not be deemed to comply with the requirements of paragraph (3) unless it is capable of complying with those requirements both at the laden weight at which it is operating at any time and when its laden weight is equal to—

- (a) if a plating certificate has been issued and is in force for the vehicle, the design gross weight shown in column (3) of that certificate or, if no such weight is so shown, the gross weight shown in column (2) of that certificate; and
- (b) in any other case, the design gross weight of the vehicle.

Provided that in the case of a goods vehicle drawing a trailer, references in this paragraph to laden weight refer to the combined laden weight of the drawing vehicle and the trailer and references to gross weight and design gross weight are to be taken as references to train weight and design train weight respectively.

[<sup>F169</sup>(4A) A bus shall be deemed not to comply with the requirements of paragraph (3) unless it is capable of complying with those requirements both at its laden weight for the time being and at its relevant weight.

(4B) For the purposes of paragraph (4A), the relevant weight,—

- (a) in relation to a bus first used on or after 1st April 1982, is its maximum gross weight; and
- (b) in relation to a bus first used before that date, is the weight specified in paragraph (4C).

(4C) The weight referred to in paragraph (4B)(b) is—

$$X+63.5(Y+Z)\text{kg}$$

where—

X is the unladen weight of that bus in kilograms;

Y is the number of passengers that the bus is constructed or adapted to carry seated in addition to the driver; and

Z is—

- (a) in the case of a PSV which is not an articulated bus and has a standing capacity exceeding 8 persons, the standing capacity minus 8;
- (b) in the case of a PSV which is an articulated bus, the standing capacity; or
- (c) in any other case, nil.]

(5) The brakes of every agricultural motor vehicle which is first used on or after 1st June 1986 and is not driven at more than 20 mph, and of every agricultural trailer manufactured on or after 1st December 1985 shall be capable of achieving a braking efficiency of not less than 25% when the weight of the vehicle is equal to the total maximum axle weights which the vehicle is designed to have.

(6) Every vehicle or combination of vehicles specified in an item in column 2 of Table II shall be so maintained that its brakes are capable, without the assistance of stored energy, of holding it stationary on a gradient of at least the percentage specified in column 3 in that item.

**TABLE II**

(regulation 18(6))

**Status:** Point in time view as at 31/03/2009.

**Status:** This revised version has been created from an electronic version contributed by Westlaw which was originally derived from the printed publication. **Read more** (See end of Document for details) **Changes to legislation:** There are currently no known outstanding effects for the The Road Vehicles (Construction and Use) Regulations 1986. (See end of Document for details)

<i>1</i>	<i>2</i>	<i>3</i>
<i>Item</i>	<i>Class of vehicle or combination</i>	<i>Percentage gradient</i>
1	A vehicle specified in item 1 of Table I—	
	(a) when not drawing a trailer	16
	(b) when drawing a trailer	12
2	A vehicle to which requirement 18 in Schedule 3 applies by virtue of regulation 16.	16
3	A vehicle, not included in item 1, drawing a trailer manufactured on or after 1st January 1968 and required, by regulation 15 or 16, to be fitted with brakes.	16

(7) For the purpose of this regulation the date of manufacture of a trailer which is a composite trailer shall be deemed to be the same as the date of manufacture of the semi-trailer which forms part of the composite trailer.

(8) A vehicle which is subject to, and which complies with the requirements in, item 1 in Tables I and II shall not be treated as failing, by reason of its braking efficiency, to comply with regulation 15 or with [F170 Community Directives 79/489, 85/647, 88/194, 91/422 or 98/12 or with ECE Regulation 13.03, 13.04, 13.05, 13.06, 13.07, 13.08 or 13.09].

[F171(9) In this regulation—

“PSV” means a public service vehicle within the meaning of section 1 of the Public Passenger Vehicles Act 1981;

“standing capacity”, in relation to a PSV, means the number of persons that can be carried standing without an offence being committed under section 26 of the Public Passenger Vehicles Act 1981.]

#### **Textual Amendments**

**F163** Reg. 18(1A)(1B) inserted (1.4.1992) by The Road Vehicles (Construction and Use) (Amendment) Regulations 1992 (S.I. 1992/352), regs. 1, **6(2)**

**F164** Reg. 18(1C) inserted (1.5.2002) by The Road Vehicles (Construction and Use) (Amendment) (No. 4) Regulations 2001 (S.I. 2001/3208), regs. 1(2), **9(2)**

**F165** Word in reg. 18(2)(b) omitted (1.4.1995) by virtue of The Road Vehicles (Construction and Use) (Amendment) Regulations 1995 (S.I. 1995/551), regs. 1, **6(2)**

**F166** Reg. 18(2)(d) and word inserted (1.4.1995) by The Road Vehicles (Construction and Use) (Amendment) Regulations 1995 (S.I. 1995/551), regs. 1, **6(2)**

**F167** Words in reg. 18 Table 1 substituted (1.5.2002) by The Road Vehicles (Construction and Use) (Amendment) (No. 4) Regulations 2001 (S.I. 2001/3208), regs. 1(2), **9(3)**

**F168** Words in reg. 18(3) Table 1 Item 3 inserted (1.4.1995) by The Road Vehicles (Construction and Use) (Amendment) Regulations 1995 (S.I. 1995/551), regs. 1, **6(3)(b)**

**F169** Reg. 18(4A)(4B)(4C) inserted (1.4.1995) by The Road Vehicles (Construction and Use) (Amendment) Regulations 1995 (S.I. 1995/551), regs. 1, **6(4)**

**F170** Words in reg. 18(8) substituted (1.5.2002) by The Road Vehicles (Construction and Use) (Amendment) (No. 4) Regulations 2001 (S.I. 2001/3208), regs. 1(2), **9(4)**

**F171** Reg. 18(9) inserted (1.4.1995) by The Road Vehicles (Construction and Use) (Amendment) Regulations 1995 (S.I. 1995/551), regs. 1, **6(6)**

Status: This revised version has been created from an electronic version contributed by Westlaw which was originally derived from the printed publication. Read more (See end of Document for details) Changes to legislation: There are currently no known outstanding effects for the The Road Vehicles (Construction and Use) Regulations 1986. (See end of Document for details)

**Commencement Information**

I16 Reg. 18 in force at 11.8.1986, see reg. 1

**Application of brakes of trailers**

19. Where a trailer is drawn by a motor vehicle the driver (or in the case of a locomotive one of the persons employed in driving or tending the locomotive) shall be in a position readily to operate any brakes required by these Regulations to be fitted to the trailer as well as the brakes of the motor vehicle unless a person other than the driver [F172(or in the case of a locomotive a person other than one of the persons employed in driving or tending the locomotive)] is in a position and competent efficiently to apply the brakes of the trailer.

Provided that this regulation shall not apply to a trailer which—

- (a) in compliance with these Regulations, is fitted with brakes which automatically come into operation on the overrun of the trailer; or
- (b) F173... is a broken down vehicle being drawn, whether or not in consequence of a breakdown, in such a manner that it cannot be steered by its own steering gear.

**Textual Amendments**

F172 Words in reg. 19 inserted (2.11.1990) by The Road Vehicles (Construction and Use) (Amendment) (No. 4) Regulations 1990 (S.I. 1990/1981), regs. 1, 12(1)

F173 Word in reg. 19(b) omitted (2.11.1990) by virtue of The Road Vehicles (Construction and Use) (Amendment) (No. 4) Regulations 1990 (S.I. 1990/1981), regs. 1, 12(1)

**Commencement Information**

I17 Reg. 19 in force at 11.8.1986, see reg. 1

C

WHEELS, SPRINGS, TYRES AND TRACKS

**General requirement as to wheels and tracks**

20. Every motor cycle and invalid carriage shall be a wheeled vehicle, and every other motor vehicle and every trailer shall be either a wheeled vehicle or a track-laying vehicle.

**Commencement Information**

I18 Reg. 20 in force at 11.8.1986, see reg. 1

**Diameter of wheels**

F174 21. ....

**Textual Amendments**

F174 Reg. 21 omitted (1.6.1995) by virtue of The Road Vehicles (Construction and Use) (Amendment) (No. 3) Regulations 1995 (S.I. 1995/1201), regs. 1, 4

**Status:** Point in time view as at 31/03/2009.

**Status:** This revised version has been created from an electronic version contributed by Westlaw which was originally derived from the printed publication. **Read more** (See end of Document for details)**Changes to legislation:** There are currently no known outstanding effects for the The Road Vehicles (Construction and Use) Regulations 1986. (See end of Document for details)

## Springs and resilient material

**22.**—(1) Save as provided in paragraphs (3) and (4), every motor vehicle and every trailer shall be equipped with suitable and sufficient springs between each wheel and the frame of the vehicle.

(2) Save as provided in paragraphs (3) and (4) in the case of a track-laying vehicle—

- (a) resilient material shall be interposed between the rims of the weight-carrying rollers and the road surface so that the weight of the vehicle, other than that borne by any wheel, is supported by the resilient material; and
- (b) where the vehicle is a heavy motor car, motor car, or trailer it shall have suitable springs between the frame of the vehicle and the weight-carrying rollers.

(3) This regulation does not apply to—

- (a) a wheeled vehicle with an unladen weight not exceeding 4070 kg and which is—
  - (i) a motor tractor any unsprung wheel of which is fitted with a pneumatic tyre;
  - (ii) a motor tractor used in connection with railway shunting and which is used on a road only when passing from one railway track to another in connection with such use;
  - (iii) a vehicle specially designed, and mainly used, for work on rough ground or unmade roads and every wheel of which is fitted with a pneumatic tyre and which is not driven at more than 20 mph;
  - (iv) a vehicle constructed or adapted for, and being used for, road sweeping and every wheel of which is fitted with either a pneumatic tyre or a resilient tyre and which is not driven at more than 20 mph;
- (b) an agricultural motor vehicle which is not driven at more than 20 mph;
- (c) an agricultural trailer, or an agricultural trailed appliance;
- (d) a trailer used solely for the haulage of felled trees;
- (e) a motor cycle;
- (f) a mobile crane;
- (g) a pedestrian-controlled vehicle all the wheels of which are equipped with pneumatic tyres;
- (h) a road roller;
- (i) a broken down vehicle; or
- (j) a vehicle first used on or before 1st January 1932.

(4) Paragraphs (1) and (2)(b) do not apply to a works truck or a works trailer.

### Commencement Information

**I19** [Reg. 22](#) in force at 11.8.1986, see [reg. 1](#)

## Wheel loads

**23.**—(1) Subject to paragraph (2) this regulation applies to—

- (a) a semi-trailer with more than 2 wheels;
- (b) a track-laying vehicle with more than 2 wheels; and
- (c) any other vehicle with more than 4 wheels.

(2) This regulation does not apply to a road roller.

(3) Save as provided in paragraphs (4) and (5), every vehicle to which this regulation applies shall be fitted with a compensating arrangement which will ensure that under the most adverse conditions



**Status:** This revised version has been created from an electronic version contributed by Westlaw which was originally derived from the printed publication. **Read more** (See end of Document for details)**Changes to legislation:** There are currently no known outstanding effects for the The Road Vehicles (Construction and Use) Regulations 1986. (See end of Document for details)

every wheel will remain in contact with the road and will not be subject to abnormal variations of load.

(4) Paragraph (3) does not apply in respect of a steerable wheel on which the load does not exceed—

- (a) if it is a wheeled vehicle, [<sup>F175</sup>4250 kg]; and
- (b) if it is a track-laying vehicle, 2540 kg.

(5) In the application of paragraph (3) to an agricultural motor vehicle, wheels which are in line transversely on one side of the longitudinal axis of the vehicle shall be regarded as one wheel.

**Textual Amendments**

**F175** Word in reg. 23(4)(a) substituted (1.1.1999) by [The Road Vehicles \(Construction and Use\) \(Amendment\) \(No. 7\) Regulations 1998](#) (S.I. 1998/3112), regs. 1, 5

**Commencement Information**

**I20** [Reg. 23](#) in force at 11.8.1986, see [reg. 1](#)

**Tyres**

24.—(1) Save as provided in paragraph (2), every wheel of a vehicle of a class specified in an item in column 2 of the Table shall be fitted with a tyre of a type specified in that item in column 3 which complies with any conditions specified in that item in column 4.

(2) The requirements referred to in paragraph (1) do not apply to a road roller and are subject, in the case of any item in the Table, to the exemptions specified in that item in column 5.

**TABLE**

(regulation 24(1))

<i>1</i> <i>Item</i>	<i>2</i> <i>Class of vehicle</i>	<i>3</i> <i>Type of tyre</i>	<i>4</i> <i>Conditions</i>	<i>5</i> <i>Exemptions</i>
1	Locomotives not falling in item 6	Pneumatic or resilient		
2	Motor tractors not falling in item 6	Pneumatic or resilient	No re-cut pneumatic tyre shall be fitted to any wheel of a vehicle with an unladen weight of less than 2540 kg unless the diameter of the rim of the wheel is at least 405 mm	
3	Heavy motor cars not falling in item 6	Pneumatic		The following, if every wheel not fitted with a pneumatic tyre is fitted with a resilient tyre—  (a) a vehicle mainly used for work on rough ground;

**Status:** Point in time view as at 31/03/2009.

**Status:** This revised version has been created from an electronic version contributed by Westlaw which was originally derived from the printed publication. **Read more** (See end of Document for details)**Changes to legislation:** There are currently no known outstanding effects for the The Road Vehicles (Construction and Use) Regulations 1986. (See end of Document for details)

1 Item	2 Class of vehicle	3 Type of tyre	4 Conditions	5 Exemptions
4	Motor cars not falling in item 6	Pneumatic	<p>No re-cut tyre shall be fitted to any wheel of a vehicle unless it is—</p> <p>(a) an electrically propelled goods vehicle or,</p> <p>(b) a goods vehicle with an unladen weight of at least 2540 kg and the diameter of the rim of the wheel is at least 405 mm.</p>	<p>(b) a tower wagon;</p> <p>(c) a vehicle fitted with a turn-table fire escape;</p> <p>(d) a refuse vehicle;</p> <p>(e) a works truck;</p> <p>(f) a vehicle first used before 3rd January 1933.</p> <p>The following, if every wheel not fitted with a pneumatic tyre is fitted with a resilient tyre—</p> <p>(a) a vehicle mainly used for work on rough ground;</p> <p>(b) a refuse vehicle;</p> <p>(c) a works truck;</p> <p>(d) a vehicle with an unladen weight not exceeding—</p> <p>(i) 1270 kg if electrically propelled;</p> <p>(ii) 1020 kg in any other case;</p> <p>(e) a tower wagon;</p> <p>(f) a vehicle fitted with a turn-table fire escape;</p> <p>(g) a vehicle first used before 3rd January 1933.</p>
5	Motor cycles	Pneumatic	No re-cut tyre shall be fitted	<p>The following, if every wheel not fitted with a pneumatic tyre is fitted with a resilient tyre—</p> <p>(a) a works truck;</p> <p>(b) a pedestrian-controlled vehicle</p>
6	Agricultural motor vehicles which are not	Pneumatic or resilient	The same as for item 2	The requirement in column 3 does not

**Status:** This revised version has been created from an electronic version contributed by Westlaw which was originally derived from the printed publication. **Read more** (See end of Document for details)**Changes to legislation:** There are currently no known outstanding effects for the The Road Vehicles (Construction and Use) Regulations 1986. (See end of Document for details)

1 Item	2 Class of vehicle driven at more than 20 mph	3 Type of tyre	4 Conditions	5 Exemptions apply to a vehicle of which— (a) every steering wheel is fitted with a smooth- soled tyre which is not less than 60 mm wide where it touches the road; and (b) in the case of a wheeled vehicle, every driving wheel is fitted with a smooth- soled tyre which — (i) is not less than 150 mm wide if the unladen weight of the vehicle exceeds 3050 kg, or 76 mm wide in any other case, and either (ii) is shod with diagonal cross-bars not less than 76 mm wide or more than 20 mm thick extending the full breadth of the tyre and so arranged that the space between adjacent bars is not more than 76 mm; or
-----------	--	-------------------	-----------------	---

**Status:** Point in time view as at 31/03/2009.

**Status:** This revised version has been created from an electronic version contributed by Westlaw which was originally derived from the printed publication. **Read more** (See end of Document for details)**Changes to legislation:** There are currently no known outstanding effects for the The Road Vehicles (Construction and Use) Regulations 1986. (See end of Document for details)

1 Item	2 Class of vehicle	3 Type of tyre	4 Conditions	5 Exemptions (iii) is shod with diagonal cross-bars of resilient material not less than 60 mm wide extending the full breadth of the tyre and so arranged that the space between adjacent bars is not more than 76 mm.
7	Trailers	Pneumatic	<p>Except in the case of a trailer mentioned in paragraph (d) of column 5, no re-cut tyre shall be fitted to any wheel of a trailer drawn by a heavy motor car or a motor car if the trailer—</p> <p>(a) has an unladen weight not exceeding—</p> <p>(i) if it is a living van, 2040 kg; or</p> <p>(ii) in any other case, 1020 kg; or</p> <p>(b) is not constructed or adapted to carry any load, other than plant or other special appliance which is a permanent or essentially permanent fixture and has a</p>	<p>(a) an agricultural trailer manufactured before 1st December 1985;</p> <p>(b) an agricultural trailed appliance;</p> <p>(c) a trailer used to carry water for a road roller being used in connection with road works;</p> <p>(d) the following if every wheel which is not fitted with a pneumatic tyre is fitted with a resilient tyre—</p> <p>(i) a works trailer;</p> <p>(ii) a refuse vehicle;</p> <p>(iii) a trailer drawn by a heavy motor car every</p>

**Status:** This revised version has been created from an electronic version contributed by Westlaw which was originally derived from the printed publication. **Read more** (See end of Document for details)**Changes to legislation:** There are currently no known outstanding effects for the The Road Vehicles (Construction and Use) Regulations 1986. (See end of Document for details)

<i>1</i> <i>Item</i>	<i>2</i> <i>Class of vehicle</i>	<i>3</i> <i>Type of tyre</i>	<i>4</i> <i>Conditions</i> gross weight not exceeding 2290 kg	<i>5</i> <i>Exemptions</i> wheel of which is not required to be fitted with a pneumatic tyre; (iv) a broken down vehicle; or (v) a trailer drawn by a vehicle which is not a heavy motor car or a motor car.
-------------------------	-------------------------------------	---------------------------------	---	--

(3) Save as provided in paragraph (4) a wheel of a vehicle may not be fitted with a temporary use spare tyre unless either—

- (a) the vehicle is a passenger vehicle (not being a bus) first used before 1st April 1987; or
- (b) the vehicle complies at the time of its first use with ECE Regulation 64 <sup>F176</sup> or Community Directive 92/23].

(4) Paragraph (3) does not apply to a vehicle constructed or assembled by a person not ordinarily engaged in the trade or business of manufacturing vehicles of that description.

#### Textual Amendments

**F176** Words in [reg. 24\(3\)\(b\)](#) inserted (1.1.1993) by [The Road Vehicles \(Construction and Use\) \(Amendment\) \(No. 7\) Regulations 1992 \(S.I. 1992/3088\)](#), regs. 1, 3

#### Commencement Information

**I21** [Reg. 24](#) in force at 11.8.1986, see [reg. 1](#)

### Tyre Loads and Speed Ratings

<sup>F177</sup>**25.**—(1) Save as provided in [<sup>F178</sup>paragraphs (3), (4), (7A) and (7B)] any tyre fitted to the axle of a vehicle—

- (a) which is a class of vehicle specified in an item in column 2 of Table I; and
  - (b) in relation to which the date of first use is as specified in that item in column 3 of that Table;
- shall comply with the requirements specified in that item in column 4 of that Table.

**Status:** Point in time view as at 31/03/2009.

**Status:** This revised version has been created from an electronic version contributed by Westlaw which was originally derived from the printed publication. **Read more** (See end of Document for details)**Changes to legislation:** There are currently no known outstanding effects for the The Road Vehicles (Construction and Use) Regulations 1986. (See end of Document for details)

[<sup>F179</sup>TABLE I

(regulation 25(1))

<i>1</i> <i>Item</i>	<i>2</i> <i>Class of vehicle</i>	<i>3</i> <i>Date of first use</i>	<i>4</i> <i>Requirements</i>
1	Vehicles which are of one or more of the following descriptions, namely— (a) goods vehicles, (b) trailers, (c) buses, (d) vehicles of a class mentioned in column 2 in Table III	Before 1st April 1991	The requirements of paragraphs (5) and (6)
2	Vehicles which are of one or more of the following descriptions— (a) goods vehicles, (b) trailers, (c) buses, (d) vehicles of a class mentioned in column 2 in Table III, and do not fall within item 3 below	On or after 1st April 1991	The requirements of paragraphs (5), (6) and (7)
3	Vehicles of a class mentioned in paragraph (2)	On or after 1st April 1991	The requirements of paragraph (5)]

[<sup>F180</sup>(2) The classes of vehicle referred to in item 3 in column 2 of Table I are—

- (a) engineering plant;
- (b) track-laying vehicles;
- (c) vehicles equipped with tyres of speed category Q;
- (d) works trucks; and
- (e) motor vehicles with a maximum speed not exceeding 30 mph, not being vehicles of a class specified in—
  - (i) items 2 and 3 of Table II; or
  - (ii) paragraph (7A) or sub-paragraphs (a) to (d) of this paragraph; or trailers while being drawn by such vehicles.]

(3) Paragraph (1) shall not apply to any tyre fitted to the axle of a vehicle if the vehicle is—

- (a) broken down or proceeding to a place where it is to be broken up; and
- (b) being drawn by a motor vehicle at a speed not exceeding 20 mph.

**Status:** This revised version has been created from an electronic version contributed by Westlaw which was originally derived from the printed publication. **Read more** (See end of Document for details)**Changes to legislation:** There are currently no known outstanding effects for the The Road Vehicles (Construction and Use) Regulations 1986. (See end of Document for details)

(4) Where in relation to any vehicle first used on or after 1st April 1991 a tyre supplied by a manufacturer for the purposes of tests or trials of that tyre is fitted to an axle of that vehicle, <sup>F181</sup>paragraph (7) shall not apply to that tyre while it is being used for those purposes.]

(5) The requirements of this paragraph are that the tyre, as respects strength, shall be designed and manufactured adequately to support the maximum permitted axle weight for the axle.

(6) The requirements of this paragraph are that the tyre shall be designed and <sup>F182</sup>manufactured] adequately to support the maximum permitted axle weight for the axle when the vehicle is driven at the speed shown in column 3 in Table II in the item in which the vehicle is described in column 2 (the lowest relevant speed being applicable to a vehicle which is described in more than one item).

TABLE II

(regulation 25(6))

1 Item	2 Class of vehicle	3 Speed (mph)	4 Variation to the <sup>F183</sup> load-capacity index] expressed as a percentage <i>[<sup>F183</sup>Tyres marked in accordance with ECE Regulation 30, 30.01 or 30.02][<sup>F184</sup>and relevant car tyres]</i>	
1	A vehicle of a class for which maximum speeds are prescribed by Schedule 6 to the 1984 Act <sup>F186</sup> other than an agricultural motor vehicle]	The highest speed so prescribed	Single wheels: none	None
			Dual wheels: 95.5%	
2	An electrically propelled vehicle used as a multi-stop local collection and delivery vehicle and having a maximum speed of not more than 25 mph	<sup>F187</sup> The maximum speed of the vehicle]	None	150%
3	An electrically propelled vehicle used as a multi-	<sup>F188</sup> The maximum speed of the vehicle]	None	130%

**Status:** Point in time view as at 31/03/2009.

**Status:** This revised version has been created from an electronic version contributed by Westlaw which was originally derived from the printed publication. **Read more** (See end of Document for details)**Changes to legislation:** There are currently no known outstanding effects for the The Road Vehicles (Construction and Use) Regulations 1986. (See end of Document for details)

1 Item	2 Class of vehicle	3 Speed (mph)	4 Variation to the [ <sup>F183</sup> load-capacity index] expressed as a percentage <i>[<sup>F183</sup>Tyres marked in accordance with ECE Regulation 30, 30.01 or 30.02][<sup>F184</sup>and relevant car tyres]</i>	
	stop local collection and delivery vehicle and having a maximum speed of more than 25 mph and not more than 40 mph			
4	An electrically propelled vehicle used only within a radius of 25 miles from the permanent base at which it is normally kept and having a maximum speed of more than 40 mph and not more than 50 mph	[ <sup>F189</sup> The maximum speed of the vehicle]	None	115%
5	A local service bus	50	None	110%
6	A restricted speed vehicle	50	None	The relevant % variation specified in Annex 8 to ECE Regulation 54 [ <sup>F190</sup> or Appendix 8 to Annex II to Community Directive 92/23]
7	A low platform trailer [ <sup>F191</sup> , an agricultural motor vehicle, an agricultural trailer, an agricultural	40	None	The relevant % variation specified in Annex 8 to ECE Regulation 54 [ <sup>F190</sup> or Appendix 8 to Annex II



**Status:** This revised version has been created from an electronic version contributed by Westlaw which was originally derived from the printed publication. **Read more** (See end of Document for details)**Changes to legislation:** There are currently no known outstanding effects for the The Road Vehicles (Construction and Use) Regulations 1986. (See end of Document for details)

1 Item	2 Class of vehicle	3 Speed (mph)	4 Variation to the [ <sup>F183</sup> load-capacity index] expressed as a percentage <i>[<sup>F183</sup>Tyres marked in accordance with ECE Regulation 30, 30.01 or 30.02][<sup>F184</sup>and relevant car tyres]</i>	
	trailed appliance or an agricultural trailed appliance conveyor]			to Community Directive 92/23]
8	A municipal vehicle	40	None	115%
9	A multi-stop local collection and delivery vehicle if not falling within the class of vehicle described in items 2 or 3 above	40	None	115%
10	A light trailer or any trailer equipped with tyres of speed category F or G	60	Single wheels: 110%  Dual wheels: 105%	The relevant variation specified in Annex 8 to ECE Regulation 54 [ <sup>F190</sup> or Appendix 8 to Annex II to Community Directive 92/23]
11	A trailer not falling in items 6–10	60	Single wheels: none  Dual wheels: 95.5%	None
12	A [ <sup>F192</sup> motor] vehicle not falling in items 1–11	70	Single wheels: none  Dual wheels: 95.5%	None

**Status:** Point in time view as at 31/03/2009.

**Status:** This revised version has been created from an electronic version contributed by Westlaw which was originally derived from the printed publication. **Read more** (See end of Document for details)**Changes to legislation:** There are currently no known outstanding effects for the The Road Vehicles (Construction and Use) Regulations 1986. (See end of Document for details)

(7) The requirement of this paragraph is that the tyre when first fitted to the vehicle [<sup>F193</sup>was marked with a designated approval mark or] complied with the requirements of [<sup>F194</sup>ECE Regulation 30, 30.01, 30.02] or 54, but this requirement shall not apply to a retreaded tyre.

[<sup>F195</sup>(7A) The requirements of paragraphs (6) and (7) shall not apply to [<sup>F196</sup>any tyre fitted to the axle of] a vehicle of a class specified in an item in column 2 of Table III while [<sup>F197</sup>the vehicle] is being driven or drawn at a speed not exceeding that specified in that item in column 3 of that Table.

**TABLE III**

(regulation 25(7A))

<i>1</i> <i>Item</i>	<i>2</i> <i>Class of vehicle</i>	<i>3</i> <i>Speed (mph)</i>
1	Agricultural motor vehicles	20
2	Agricultural trailers	20
3	Agricultural trailed appliances	20
4	Agricultural trailed appliance conveyors	20
5	Works trailers	18]

[<sup>F198</sup>(7B) Paragraph (7C) applies where a tyre fitted to the axle of a vehicle—

- (a) bears a speed category symbol and load–capacity index, being marks that were moulded on to or into the tyre at the time that it was manufactured;
- (b) is designed and manufactured so as to be capable of operating safely at the speed and load indicated by those marks; and
- (c) is designed so as to be capable of being fitted to the axle of a vehicle of a class specified in item 1, 2, 3 or 4 in column 2 of Table III above.

(7C) In the circumstances mentioned in paragraph (7B), paragraph (7) shall not apply to the tyre if—

- (a) the vehicle is being driven or drawn at a speed that does not exceed the speed indicated by the speed category symbol or 50 mph (whichever is the less), and
- (b) the load on the tyre does not exceed the load indicated by the load–capacity index.]

(8) A vehicle of a class described in column 2 in Table II first used on or after 1st April 1991 shall not be used on a road—

- (a) in the case where there is no entry in column 4 specifying a variation to the [<sup>F199</sup>load-capacity index] expressed as a percentage, if the load applied to any tyre fitted to the axle of the vehicle exceeds that indicated by the [<sup>F199</sup>load-capacity index]; or
- (b) in the case where there is such an entry in column 4, if the load applied to any tyre fitted to the axle of the vehicle exceeds the variation to the [<sup>F199</sup>load-capacity index] expressed as a percentage.

(9) In this regulation—

[<sup>F200</sup>“designated approval mark” means the marking designated as an approval mark by regulation 5 of the Approval Marks Regulations and shown at item 33 in Schedule 4 to those Regulations (that item being a marking relating to Community Directive 92/23);]

**Status:** This revised version has been created from an electronic version contributed by Westlaw which was originally derived from the printed publication. **Read more** (See end of Document for details)**Changes to legislation:** There are currently no known outstanding effects for the The Road Vehicles (Construction and Use) Regulations 1986. (See end of Document for details)

“dual wheels” means two or more wheels which are to be regarded as one wheel by virtue of paragraph 7 of regulation 3 in the circumstances specified in that paragraph;

“load-capacity index” has the same meaning as in [<sup>F201</sup>paragraph 2.28 of Annex II to Community Directive 92/23 or] paragraph 2.29 of ECE Regulation 30.02 or [<sup>F202</sup>paragraph 2.27] of ECE Regulation 54;

“local service bus” means a bus being used in the provision of a local service as defined in section 2 of the Transport Act 1985;

“municipal vehicle” means a motor vehicle or trailer limited at all times to use by a local authority, or a person acting in pursuance of a contract with a local authority, for road cleansing, road watering or the collection and disposal of refuse, night soil or the contents of cesspools, or the purposes of the enactments relating to weights and measures or the sale of food and drugs;

“multi-stop local collection and delivery vehicle” means a motor vehicle or trailer used for multi-stop collection and delivery services to be used only within a radius of 25 miles from the permanent base at which it is normally kept;

“single wheels” means wheels which are not dual wheels; and

“speed category” has the same meaning as in [<sup>F203</sup>paragraph 2.29 of Annex II to Community Directive 92/23 or][<sup>F204</sup>paragraph 2.28] of ECE Regulation 54.

[<sup>F205</sup>(9A) For the purposes of this regulation, a tyre is a “relevant car tyre” if—

- (a) it has been marked with a designated approval mark, and
- (b) the first two digits of the approval number comprised in the mark are “02”.

(9B) For the purposes of this regulation, a tyre is a “relevant commercial vehicle tyre” if—

- (a) it has been marked with a designated approval mark, and
- (b) the first two digits of the approval number comprised in the mark are “00”.]

(10) In this regulation any reference to the first use shall, in relation to a trailer, be construed as a reference to the date which is 6 months after the date of manufacture of the trailer.]

#### Textual Amendments

- F177** Reg. 25 substituted (2.11.1990) by [The Road Vehicles \(Construction and Use\) \(Amendment\) \(No. 4\) Regulations 1990 \(S.I. 1990/1981\)](#), regs. 1, **7** (with reg. 2(2))
- F178** Words in reg. 25(1) substituted (1.4.1995) by [The Road Vehicles \(Construction and Use\) \(Amendment\) Regulations 1995 \(S.I. 1995/551\)](#), regs. 1, **7(2)**
- F179** Reg. 25 Table 1 substituted (1.1.1992) by [The Road Vehicles \(Construction and Use\) \(Amendment\) \(No. 5\) Regulations 1991 \(S.I. 1991/2710\)](#), regs. 1, **3(3)**
- F180** Reg. 25(2) substituted (1.1.1992) by [The Road Vehicles \(Construction and Use\) \(Amendment\) \(No. 5\) Regulations 1991 \(S.I. 1991/2710\)](#), regs. 1, **3(4)**
- F181** Words in reg. 25(4) substituted (1.1.1992) by [The Road Vehicles \(Construction and Use\) \(Amendment\) \(No. 5\) Regulations 1991 \(S.I. 1991/2710\)](#), regs. 1, **3(5)**
- F182** Word in reg. 25(6) substituted (1.1.1992) by [The Road Vehicles \(Construction and Use\) \(Amendment\) \(No. 5\) Regulations 1991 \(S.I. 1991/2710\)](#), regs. 1, **3(6)**
- F183** Words in reg. 25 Table 2 substituted (1.1.1992) by [The Road Vehicles \(Construction and Use\) \(Amendment\) \(No. 5\) Regulations 1991 \(S.I. 1991/2710\)](#), regs. 1, **3(7)(a)**
- F184** Words in reg. 25 Table 2 inserted (1.1.1993) by [The Road Vehicles \(Construction and Use\) \(Amendment\) \(No. 7\) Regulations 1992 \(S.I. 1992/3088\)](#), regs. 1, **4(2)(a)**
- F185** Words in reg. 25 Table 2 inserted (1.1.1993) by [The Road Vehicles \(Construction and Use\) \(Amendment\) \(No. 7\) Regulations 1992 \(S.I. 1992/3088\)](#), regs. 1, **4(2)(b)**

**Status:** Point in time view as at 31/03/2009.

**Status:** This revised version has been created from an electronic version contributed by Westlaw which was originally derived from the printed publication. **Read more** (See end of Document for details)**Changes to legislation:** There are currently no known outstanding effects for the The Road Vehicles (Construction and Use) Regulations 1986. (See end of Document for details)

- F186** Words in reg. 25 Table 2 added (1.1.1992) by The Road Vehicles (Construction and Use) (Amendment) (No. 5) Regulations 1991 (S.I. 1991/2710), regs. 1, **3(7)(b)**
- F187** Words in reg. 25 Table 2 substituted (1.1.1992) by The Road Vehicles (Construction and Use) (Amendment) (No. 5) Regulations 1991 (S.I. 1991/2710), regs. 1, **3(7)(c)**
- F188** Words in reg. 25 Table 2 substituted (1.1.1992) by The Road Vehicles (Construction and Use) (Amendment) (No. 5) Regulations 1991 (S.I. 1991/2710), regs. 1, **3(7)(d)**
- F189** Words in reg. 25 Table 2 substituted (1.1.1992) by The Road Vehicles (Construction and Use) (Amendment) (No. 5) Regulations 1991 (S.I. 1991/2710), regs. 1, **3(7)(e)**
- F190** Words in reg. 25 Table 2 inserted (1.1.1993) by The Road Vehicles (Construction and Use) (Amendment) (No. 7) Regulations 1992 (S.I. 1992/3088), regs. 1, **4(2)(c)**
- F191** Words in reg. 25 Table 2 added (1.1.1992) by The Road Vehicles (Construction and Use) (Amendment) (No. 5) Regulations 1991 (S.I. 1991/2710), regs. 1, **3(7)(f)**
- F192** Word in reg. 25 Table 2 Item 12 inserted (1.1.1993) by The Road Vehicles (Construction and Use) (Amendment) (No. 7) Regulations 1992 (S.I. 1992/3088), regs. 1, **4(2)(d)**
- F193** Words in reg. 25(7) inserted (1.1.1993) by The Road Vehicles (Construction and Use) (Amendment) (No. 7) Regulations 1992 (S.I. 1992/3088), regs. 1, **4(3)**
- F194** Words in reg. 25(7) substituted (1.1.1992) by The Road Vehicles (Construction and Use) (Amendment) (No. 5) Regulations 1991 (S.I. 1991/2710), regs. 1, **3(8)**
- F195** Reg. 25(7A) inserted (1.1.1992) by The Road Vehicles (Construction and Use) (Amendment) (No. 5) Regulations 1991 (S.I. 1991/2710), regs. 1, **3(9)**
- F196** Words in reg. 25(7A) inserted (1.4.1995) by The Road Vehicles (Construction and Use) (Amendment) Regulations 1995 (S.I. 1995/551), regs. 1, **7(3)**
- F197** Words in reg. 25(7A) substituted (1.4.1995) by The Road Vehicles (Construction and Use) (Amendment) Regulations 1995 (S.I. 1995/551), regs. 1, **7(3)**
- F198** Reg. 25(7B)(7C) inserted (1.4.1995) by The Road Vehicles (Construction and Use) (Amendment) Regulations 1995 (S.I. 1995/551), regs. 1, **7(4)**
- F199** Words in reg. 25(8) substituted (1.1.1992) by The Road Vehicles (Construction and Use) (Amendment) (No. 5) Regulations 1991 (S.I. 1991/2710), regs. 1, **3(10)**
- F200** Words in reg. 25(9) inserted (1.1.1993) by The Road Vehicles (Construction and Use) (Amendment) (No. 7) Regulations 1992 (S.I. 1992/3088), regs. 1, **4(4)(a)**
- F201** Words in reg. 25(9) inserted (1.1.1993) by The Road Vehicles (Construction and Use) (Amendment) (No. 7) Regulations 1992 (S.I. 1992/3088), regs. 1, **4(4)(b)**
- F202** Words in reg. 25(9) substituted (1.1.1992) by The Road Vehicles (Construction and Use) (Amendment) (No. 5) Regulations 1991 (S.I. 1991/2710), regs. 1, **3(11)(a)**
- F203** Words in reg. 25(9) inserted (1.1.1993) by The Road Vehicles (Construction and Use) (Amendment) (No. 7) Regulations 1992 (S.I. 1992/3088), regs. 1, **4(4)(c)**
- F204** Words in reg. 25(9) substituted (1.1.1992) by The Road Vehicles (Construction and Use) (Amendment) (No. 5) Regulations 1991 (S.I. 1991/2710), regs. 1, **3(11)(b)**
- F205** Reg. 25(9A)(9B) inserted (1.1.1993) by The Road Vehicles (Construction and Use) (Amendment) (No. 7) Regulations 1992 (S.I. 1992/3088), regs. 1, **4(5)**

## Mixing of tyres

26.—(1) Save as provided in paragraph (5) pneumatic tyres of different types of structure shall not be fitted to the same axle of a wheeled vehicle.

(2) Save as provided in paragraphs (3) or (5), a wheeled motor vehicle having only two axles each of which is equipped with one or two single wheels shall not be fitted with—

- (a) a diagonal-ply tyre or a bias-belted tyre on its rear axle if a radial-ply tyre is fitted on its front axle; or
- (b) a diagonal-ply tyre on its rear axle if a bias-belted tyre is fitted on the front axle.

(3) Paragraph (2) does not apply to a vehicle to an axle of which there are fitted wide tyres not specially constructed for use on engineering plant or to a vehicle which has a maximum speed not exceeding 30 mph.

(4) Save as provided in paragraph (5) pneumatic tyres fitted to—

- (a) the steerable axles of a wheeled vehicle; [<sup>F206</sup>or]
- (b) the driven axles of a wheeled vehicle, not being steerable axles,

shall all be of the same type of structure.

(5) Paragraphs (1), (2), and (4) do not prohibit the fitting of a temporary use spare tyre to a wheel of a passenger vehicle (not being a bus) unless it is driven at a speed exceeding 50 mph.

(6) In this regulation—

“axle” includes—

- (i) two or more stub axles which are fitted on opposite sides of the longitudinal axis of the vehicle so as to form—
  - (a) a pair in the case of two stub axles; and
  - (b) pairs in the case of more than two stub axles; and
- (ii) a single stub axle which is not one of a pair;

“a bias-belted tyre” means a pneumatic tyre, the structure of which is such that the ply cords extend to the bead so as to be laid at alternate angles of substantially less than 90 degrees to the peripheral line of the tread, and are constrained by a circumferential belt comprising two or more layers of substantially inextensible cord material laid at alternate angles smaller than those of the ply cord structure;

“a diagonal-ply tyre” means a pneumatic tyre, the structure of which is such that the ply cords extend to the bead so as to be laid at alternate angles of substantially less than 90 degrees to the peripheral line of the tread, but not being a bias-belted tyre;

“a driven axle” means an axle through which power is transmitted from the engine of a vehicle to the wheels on that axle;

“a radial-ply tyre” means a pneumatic tyre, the structure of which is such that the ply cords extend to the bead so as to be laid at an angle of substantially 90 degrees to the peripheral line of the tread, the ply cord structure being stabilised by a substantially inextensible circumferential belt;

“stub axle” means an axle on which only one wheel is mounted; and

“type of structure”, in relation to a tyre, means a type of structure of a tyre of a kind defined in the foregoing provisions of this paragraph.

#### Textual Amendments

**F206** Word in [reg. 26\(4\)](#) substituted (2.11.1990) by [The Road Vehicles \(Construction and Use\) \(Amendment\) \(No. 4\) Regulations 1990 \(S.I. 1990/1981\)](#), [regs. 1, 8](#)

#### Commencement Information

**I22** [Reg. 26](#) in force at 11.8.1986, see [reg. 1](#)

### Condition and maintenance of tyres

27.—(1) Save as provided in paragraphs (2), (3) and (4), a wheeled motor vehicle or trailer a wheel of which is fitted with a pneumatic tyre shall not be used on a road, if—

**Status:** Point in time view as at 31/03/2009.

**Status:** This revised version has been created from an electronic version contributed by Westlaw which was originally derived from the printed publication. **Read more** (See end of Document for details) **Changes to legislation:** There are currently no known outstanding effects for the The Road Vehicles (Construction and Use) Regulations 1986. (See end of Document for details)

- (a) the tyre is unsuitable having regard to the use to which the motor vehicle or trailer is being put or to the types of tyres fitted to its other wheels;
- (b) the tyre is not so inflated as to make it fit for the use to which the motor vehicle or trailer is being put;
- (c) the tyre has a cut in excess of 25 mm or 10% of the section width of the tyre, whichever is the greater, measured in any direction on the outside of the tyre and deep enough to reach the ply or cord;
- (d) the tyre has any lump, bulge or tear caused by separation or partial failure of its structure;
- (e) the tyre has any of the ply or cord exposed;
- (f) the base of any groove which showed in the original tread pattern of the tyre is not clearly visible;
- (g) either—
  - (i) the grooves of the tread pattern of the tyre do not have a depth of at least 1 mm throughout a continuous band measuring at least three-quarters of the breadth of the tread and round the entire outer circumference of the tyre; or
  - (ii) if the grooves of the original tread pattern of the tyre did not extend beyond three-quarters of the breadth of the tread, any groove which showed in the original tread pattern does not have a depth of at least 1 mm; or
- (h) the tyre is not maintained in such condition as to be fit for the use to which the vehicle or trailer is being put or has a defect which might in any way cause damage to the surface of the road or damage to persons on or in the vehicle or to other persons using the road.

(2) Paragraph (1) does not prohibit the use on a road of a motor vehicle or trailer by reason only of the fact that a wheel of the vehicle or trailer is fitted with a tyre which is deflated or not fully inflated and which has any of the defects described in sub-paragraph (c), (d) or (e) of paragraph (1), if the tyre and the wheel to which it is fitted are so constructed as to make the tyre in that condition fit for the use to which the motor vehicle or trailer is being put and the outer sides of the wall of the tyre are so marked as to enable the tyre to be identified as having been constructed to comply with the requirements of this paragraph.

(3) Paragraph (1)(a) does not prohibit the use on a road of a passenger vehicle (not being a bus) by reason only of the fact that a wheel of the vehicle is fitted with a temporary use spare tyre, unless the vehicle is driven at a speed exceeding 50 mph.

- (a) (4) (a) Nothing in paragraph (1)(a) to (g) applies to—
  - (i) an agricultural motor vehicle that is not driven at more than 20 mph;
  - (ii) an agricultural trailer;
  - (iii) an agricultural trailed appliance; or
  - (iv) a broken down vehicle or a vehicle proceeding to a place where it is to be broken up, being drawn, in either case, by a motor vehicle at a speed not exceeding 20 mph.
- (b) Nothing in paragraph (1)(f) and (g) applies to—
  - (i) a three-wheeled motor cycle the unladen weight of which does not exceed 102 kg and which has a maximum speed of 12 mph; or
  - (ii) a pedestrian-controlled works truck.
- (c) Nothing in paragraph (1)(g) applies to a motorcycle with an engine capacity which does not exceed 50 cc.

[<sup>F207</sup>(d) With effect from 1st January 1992, paragraph 1(f) and (g) shall not apply to the vehicles specified in sub-paragraph (e) of this paragraph but such vehicles shall comply with the requirements specified in sub-paragraph (f) of this paragraph.

- (e) The vehicles mentioned in sub-paragraph (d) are—
- (i) passenger vehicles other than motor cycles constructed or adapted to carry no more than 8 seated passengers in addition to the driver;
  - (ii) goods vehicles with a maximum gross weight which [<sup>F208</sup>does] not exceed 3500 kg; and
  - (iii) light trailers not falling within sub-paragraph (ii);
- first used on or after 3rd January 1933.
- (f) The requirements referred to in sub-paragraph (d) are that the grooves of the tread pattern of every tyre fitted to the wheels of a vehicle mentioned in sub-paragraph (e) shall be of a depth of at least 1.6 mm throughout a continuous band [<sup>F209</sup>comprising] the central three-quarters of the breadth of tread and round the entire outer circumference of the tyre.]
- (5) A recut pneumatic tyre shall not be fitted to any wheel of a motor vehicle or trailer if—
- (a) its ply or cord has been cut or exposed by the recutting process; or
  - (b) it has been wholly or partially recut in a pattern other than the manufacturer's recut tread pattern.
- (a) (6) (a) In this regulation—
- “breadth of tread” means the breadth of that part of the tyre which can contact the road under normal conditions of use measured at 90 degrees to the peripheral line of the tread;
- “original tread pattern” means in the case of—
- a re-treaded tyre, the tread pattern of the tyre immediately after the tyre was re-treaded;
  - a wholly recut tyre, the manufacturer's recut tread pattern;
  - a partially recut tyre, on that part of the tyre which has been recut, the manufacturer's recut tread pattern, and on the other part, the tread pattern of the tyre when new, and
  - any other tyre, the tread pattern of the tyre when the tyre was new.
- “tie-bar” means any part of a tyre moulded in the tread pattern of the tyre for the purpose of bracing two or more features of such tread pattern;
- “tread pattern” means the combination of plain surfaces and grooves extending across the breadth of the tread and round the entire outer circumference of the tyre but excludes any—
- (i) tie bars or tread wear indicators;
  - (ii) features which are designed to wear out substantially before the rest of the pattern under normal conditions of use; and
  - (iii) other minor features; and
- “tread wear indicator” means any bar, not being a tie-bar, projecting from the base of a groove of the tread pattern of a tyre and moulded between two or more features of the tread pattern of a tyre for the purpose of indicating the extent of the wear of such tread pattern.
- (b) The references in [<sup>F210</sup>this regulation] to grooves are references—
- if a tyre has been recut, to the grooves of the manufacturer's recut tread pattern; and
  - if a tyre has not been recut, to the grooves which showed when the tyre was new.

**Status:** Point in time view as at 31/03/2009.

**Status:** This revised version has been created from an electronic version contributed by Westlaw which was originally derived from the printed publication. **Read more** (See end of Document for details)**Changes to legislation:** There are currently no known outstanding effects for the The Road Vehicles (Construction and Use) Regulations 1986. (See end of Document for details)

[<sup>F211</sup>(c) A reference in this regulation to first use shall, in relation to a trailer, be construed as a reference to the date which is 6 months after the date of manufacture of the trailer.]

#### Textual Amendments

- F207** Reg. 27(4)(d)-(f) added (2.11.1990) by The Road Vehicles (Construction and Use) (Amendment) (No. 4) Regulations 1990 (S.I. 1990/1981), regs. 1, **9(2)**
- F208** Word in reg. 27(4)(e)(ii) substituted (1.1.1992) by The Road Vehicles (Construction and Use) (Amendment) (No. 5) Regulations 1991 (S.I. 1991/2710), regs. 1, **4(a)**
- F209** Word in reg. 27(4)(f) substituted (1.1.1992) by The Road Vehicles (Construction and Use) (Amendment) (No. 5) Regulations 1991 (S.I. 1991/2710), regs. 1, **4(b)**
- F210** Words in reg. 27(6)(b) substituted (2.11.1990) by The Road Vehicles (Construction and Use) (Amendment) (No. 4) Regulations 1990 (S.I. 1990/1981), regs. 1, **9(3)**
- F211** Reg. 27(6)(c) added (2.11.1990) by The Road Vehicles (Construction and Use) (Amendment) (No. 4) Regulations 1990 (S.I. 1990/1981), regs. 1, **9(4)**

#### Commencement Information

- I23** Reg. 27 in force at 11.8.1986, see **reg. 1**

#### Tracks

**28.**—(1) Every part of every track of a track-laying vehicle which comes into contact with the road shall be flat and have a width of not less than 12.5 mm.

(2) The area of the track which is in contact with the road shall not at any time be less than 225 cm<sup>2</sup> in respect of every 1000 kg of the total weight which is transferred to the road by the tracks.

(3) The tracks of a vehicle shall not have any defect which might damage the road or cause danger to any person on or in the vehicle or using the road, and shall be properly adjusted and maintained in good and efficient working order.

#### Commencement Information

- I24** Reg. 28 in force at 11.8.1986, see **reg. 1**

## D

### STEERING

#### Maintenance of steering gear

**29.** All steering gear fitted to a motor vehicle shall at all times while the vehicle is used on a road be maintained in good and efficient working order and be properly adjusted.

#### Commencement Information

- I25** Reg. 29 in force at 11.8.1986, see **reg. 1**



**Status:** This revised version has been created from an electronic version contributed by Westlaw which was originally derived from the printed publication. **Read more** (See end of Document for details)**Changes to legislation:** There are currently no known outstanding effects for the The Road Vehicles (Construction and Use) Regulations 1986. (See end of Document for details)

## E VISION

### *View to the front*

**30.**—(1) Every motor vehicle shall be so designed and constructed that the driver thereof while controlling the vehicle can at all times have a full view of the road and traffic ahead of the motor vehicle.

(2) Instead of complying with the requirement of paragraph (1) a vehicle may comply with Community Directive 77/649, 81/643 [<sup>F212</sup>, 88/366, 90/630] or, in the case of an agricultural motor vehicle, 79/1073.

(3) All glass or other transparent material fitted to a motor vehicle shall be maintained in such condition that it does not obscure the vision of the driver while the vehicle is being driven on a road.

#### **Textual Amendments**

**F212** Words in [reg. 30\(2\)](#) inserted (7.10.1991) by [The Road Vehicles \(Construction and Use\) \(Amendment\) \(No. 3\) Regulations 1991 \(S.I. 1991/2003\)](#), [regs. 1, 3](#)

#### **Commencement Information**

**I26** [Reg. 30](#) in force at 11.8.1986, see [reg. 1](#)

### *Glass*

**31.**—(1) This regulation applies to a motor vehicle which is—

- (a) a wheeled vehicle, not being a caravan, first used before 1st June 1978;
- (b) a caravan first used before 1st September 1978; or
- (c) a track-laying vehicle.

(2) The glass fitted to any window specified in an item in column 3 of the Table of a vehicle of a class specified in that item in column 2 shall be safety glass.

### **TABLE**

(regulation 31(2))

<i>1</i> <i>Item</i>	<i>2</i> <i>Class of vehicle</i>	<i>3</i> <i>Windows</i>
1	Wheeled vehicles first used on or after 1st January 1959, being passenger vehicles or dual-purpose vehicles.	Wind screens and all outside windows.
2	Wheeled vehicles first used on or after 1st January 1959, being goods vehicles (other than dual-purpose vehicles), locomotives or motor tractors.	Windscreens and all windows in front of and on either side of the driver's seat.
3	Wheeled vehicles not mentioned in item 1 or 2.	Windscreens and windows facing to the front on the outside, except glass fitted

**Status:** Point in time view as at 31/03/2009.

**Status:** This revised version has been created from an electronic version contributed by Westlaw which was originally derived from the printed publication. **Read more** (See end of Document for details)**Changes to legislation:** There are currently no known outstanding effects for the The Road Vehicles (Construction and Use) Regulations 1986. (See end of Document for details)

<i>1</i> Item	<i>2</i> Class of vehicle	<i>3</i> Windows
4	Track-laying vehicles.	to the upper decks of a double-decked vehicle.  Windscreens and windows facing to the front.

(3) For the purposes of this regulation any windscreen or window at the front of the vehicle the inner surface of which is at an angle exceeding 30 degrees to the longitudinal axis of the vehicle shall be deemed to face to the front.

[<sup>F213</sup>(4) In this regulation and in regulation 32—

“caravan” means a trailer which is constructed (and not merely adapted) for human habitation; and

[<sup>F214</sup>“designated approval mark” means the marking designated as an approval mark by Regulation 5 of the Approval Marks Regulations and shown at item 31 or 32 in Schedule 4 to those Regulations (those items being markings relating to Community Directive 92/22); and]

“safety glass” means glass so constructed or treated that if fractured it does not fly into fragments likely to cause severe cuts.]

[<sup>F215</sup>(5) Paragraph (2) does not apply to glass which is legibly and permanently marked with a designated approval mark.]

#### Textual Amendments

**F213** Reg. 31(4) substituted (6.5.1987) by [The Road Vehicles \(Construction and Use\) \(Amendment\) Regulations 1987 \(S.I. 1987/676\)](#), regs. 1(2), **15(1)**

**F214** Words in reg. 31(4) inserted (1.1.1993) by [The Road Vehicles \(Construction and Use\) \(Amendment\) \(No. 7\) Regulations 1992 \(S.I. 1992/3088\)](#), regs. 1, **5(2)**

**F215** Reg. 31(5) inserted (1.1.1993) by [The Road Vehicles \(Construction and Use\) \(Amendment\) \(No. 7\) Regulations 1992 \(S.I. 1992/3088\)](#), regs. 1, **5(3)**

#### Commencement Information

**I27** [Reg. 31](#) in force at 11.8.1986, see [reg. 1](#)

**32.—**(1) This regulation applies to—

- (a) a caravan first used on or after 1st September 1978, and
- (b) a wheeled motor vehicle and a wheeled trailer, not being a caravan, first used on or after 1st June 1978.

(2) Save as provided in paragraphs (3) to (9) the windows specified in column 2 of Table I in relation to a vehicle of a class specified in that column shall be constructed of the material specified in column 3 of that Table.

#### TABLE I

(regulation 32(2))

*Status: This revised version has been created from an electronic version contributed by Westlaw which was originally derived from the printed publication. Read more (See end of Document for details) Changes to legislation: There are currently no known outstanding effects for the The Road Vehicles (Construction and Use) Regulations 1986. (See end of Document for details)*

<i>1</i> <i>Item</i>	<i>2</i> <i>Window</i>	<i>3</i> <i>Material</i>
1	Windscreens and other windows wholly or partly on either side of the driver's seat fitted to motor vehicles first used on or after 1st April 1985.	Specified safety glass (1980).
2	Windscreens and other windows wholly or partly on either side of the driver's seat fitted to a motor vehicles first used before 1st April 1985.	Specified safety glass, or specified safety glass (1980).
3	All other windows.	Specified safety glass, specified safety glass (1980), or safety glazing.

(3) The windscreens and all other windows of security vehicles or vehicles being used for police purposes shall not be subject to the requirements specified in paragraph (2), but shall be constructed of either safety glass or safety glazing.

(4) The windscreens of motorcycles not equipped with an enclosed compartment for the driver or for a passenger shall not be subject to the requirements specified in paragraph (2), but shall be constructed of safety glazing.

(5) Any windscreens or other windows which are wholly or partly in front of or on either side of the driver's seat, and which are temporarily fitted to motor vehicles to replace any windscreens or other windows which have broken, shall—

- (a) be constructed of safety glazing; and
- (b) be fitted only while the vehicles are being driven or towed either to premises where new windscreens or other windows are to be permanently fitted to replace the windscreens or other windows which have broken, or to complete the journey in the course of which the breakage occurred.

(6) Windows forming all or part of a screen or door in the interior of a bus first used on or after 1st April 1988, shall be constructed either of safety glazing or of specified safety glass (1980).

(7) Windows being—

- (a) windows (other than windscreens) of motor vehicles being engineering plant, industrial tractors, agricultural motor vehicles (other than agricultural motor vehicles first used on or after 1st June 1986 and driven at more than 20 mph) which are wholly or partly in front of or on either side of the driver's seat;
- (b) windows of the upper deck of a double-decked bus; or
- (c) windows in the roof of a vehicle,

shall be constructed of either specified safety glass, specified safety glass (1980) or safety glazing.

(8) In the case of motor vehicles and trailers which have not at any time been fitted with permanent windows and which are being driven or towed to a place where permanent windows are to be fitted, any temporary windscreens and any other temporary windows shall be constructed of either specified safety glass, specified safety glass (1980) or safety glazing.

(9) No requirement in this regulation that a windscreen or other window shall be constructed of specified safety glass or of specified safety glass (1980) shall apply to a windscreen or other window which is—

- (a) manufactured in France;
- (b) marked with a marking consisting of the letters “TP GS” or “TP GS E”; and

**Status:** Point in time view as at 31/03/2009.

**Status:** This revised version has been created from an electronic version contributed by Westlaw which was originally derived from the printed publication. **Read more** (See end of Document for details)**Changes to legislation:** There are currently no known outstanding effects for the The Road Vehicles (Construction and Use) Regulations 1986. (See end of Document for details)

(c) fitted to a vehicle first used before 1st October 1986.

(10) Save as provided in paragraph (11), the windscreens or other windows constructed in accordance with the foregoing provisions of this regulation of specified safety glass, specified safety glass (1980) or safety glazing and specified in column 3 of Table II in relation to a vehicle of a class specified in column 2 of that Table shall have a visual transmission for light of not less than the percentage specified in relation to those windows in column 4 when measured perpendicular to the surface in accordance with the procedure specified in a document specified in relation to those windows in column 5.

**TABLE II**

(regulation 32(10))

<i>1</i> <i>Item</i>	<i>2</i> <i>Class of Vehicles</i>	<i>3</i> <i>Windows</i>	<i>4</i> <i>Percentage</i>	<i>5</i> <i>Documents specifying procedure</i>
1	Motor vehicles first used before 1st April 1985	All windows	70	British Standard Specification No. 857 or No. 5282
2	Motor vehicles first used on or after 1st April 1985 and trailers	(a) Windscreens	75	The documents mentioned in subparagraph (i), (ii) or (iii) of the definition in paragraph (13) of "specified safety glass (1980)."
		(b) All other windows	70	

(11) Paragraph (10) does not apply to—

- (a) any part of any windscreen which is outside the vision reference zone;
- (b) windows through which the driver when in the driver's seat is unable at any time to see any part of the road on which the vehicle is waiting or proceeding;
- (c) windows in any motor ambulance which are not wholly or partly in front of or on either side of any part of the driver's seat; or
- (d) windows in any bus, goods vehicle, locomotive, or motor tractor other than windows which—
  - (i) are wholly or partly in front of or on either side of any part of the driver's seat;
  - (ii) face the rear of the vehicle; or
  - (iii) form the whole or part of a door giving access to or from the exterior of the vehicle.

[<sup>F216</sup>(11A) Paragraphs (10) and (11) have effect in relation to any tint, film or other substance or material applied to a windscreen or window as they have effect in relation to the windscreen or window itself.]

(12) For the purposes of this regulation any window at the rear of the vehicle is deemed to face the rear of the vehicle if the inner surface of such window is at an angle exceeding 30 degrees to the longitudinal axis of the vehicle.

[<sup>F217</sup>(12A) Paragraphs (2), (6), (7) and (8) do not apply to a window which is legibly and permanently marked with a designated approval mark.

(12B) Paragraph (10) does not apply to a window if—

- (a) it is a window to which paragraph 12C applies and is legibly and permanently marked with a designated approval mark which does not comprise the Roman numeral “V” (other than as part of the combination “VI”); or
- (b) it is not a window to which paragraph 12C applies and is legibly and permanently marked with a designated approval mark.

(12C) This paragraph applies to a side or rear window if—

- (a) any part of it is on either side of or forward of the driver’s seat; or
- (b) any part of it is within the driver’s indirect field of view obtained by means of the mirror or mirrors which are required to be fitted by regulation 33 when such mirrors are properly adjusted;

and for the purposes of this paragraph a mirror shall not be regarded as being required to be fitted by regulation 33 if, were it to be removed, the vehicle would nevertheless meet the requirements of regulation 33.]

(13) In this regulation, unless the context otherwise requires—

“British Standard Specification No. 857” means the British Standard Specification for Safety Glass for Land Transport published on 30th June 1967 under the number BS 857 as amended by Amendment Slip No. 1 published on 15th January 1973 under the number AMD 1088;

“British Standard Specification No. 5282” means the British Standard Specification for Road Vehicle Safety Glass published in December 1975 under the number BS 5282 as amended by Amendment Slip No. 1 published on 31st March 1976 under the number AMD 1927, and as amended by Amendment Slip No. 2 published on 31st January 1977 under the number AMD 2185;

“British Standard Specification BS AU 178” means the British Standard Specification for Road Vehicle Safety Glass published on 28th November 1980 under the number BS AU 178;

F218 ...

F218 ...

[<sup>F219</sup>“designated approval mark” means—

- (a) in relation to a windscreen, the marking designated as an approval mark by regulation 5 of the Approval Marks Regulations and shown at item 31 in Schedule 4 to those Regulations, and
- (b) in relation to a window other than a windscreen, the markings designated as approval marks by regulation 5 of those Regulations and shown at item 32 in Schedule 4 to those Regulations.]

“safety glazing” means material (other than glass) which is so constructed or treated that if fractured it does not fly into fragments likely to cause severe cuts;

“security vehicle” means a motor vehicle which is constructed (and not merely adapted) for the carriage of either—

- (i) persons who are likely to require protection from any criminal offence involving violence; or
- (ii) dangerous substances, bullion, money, jewellery, documents or other goods or burden which, by reason of their nature or value, are likely to require protection from any criminal offence;

**Status:** Point in time view as at 31/03/2009.

**Status:** This revised version has been created from an electronic version contributed by Westlaw which was originally derived from the printed publication. **Read more** (See end of Document for details)**Changes to legislation:** There are currently no known outstanding effects for the The Road Vehicles (Construction and Use) Regulations 1986. (See end of Document for details)

“specified safety glass” means glass complying with the requirements of either—

- (i) British Standard Specification No. 857 (including the requirements as to marking); or
- (ii) British Standard Specification No. 5282 (including the requirements as to marking);

“specified safety glass (1980)” means glass complying with the requirements of either—

- (i) the British Standard Specification for Safety Glass for Land Transport published on 30th June 1967 under the number BS 857 as amended by Amendment Slip No. 1 published on 15th January 1973 under the number AMD 1088, Amendment Slip No. 2 published on 30th September 1980 under the number AMD 3402, and Amendment Slip No. 4 published on 15th February 1981 under the number AMD 3548 (including the requirements as to marking); or
- (ii) British Standard Specification BS AU 178 (including the requirements as to marking); or
- (iii) ECE Regulation 43 (including the requirements as to marking).

“vision reference zone” means either—

- (i) the primary vision area as defined in British Standard Specification No. 857;
- (ii) Zone 1, as defined in British Standard Specification No. 5282;
- (iii) Zone B (as regards passenger vehicles other than buses) and Zone 1 (as regards all other vehicles) as defined in British Standard Specification BS AU 178 and in ECE Regulation 43; and

“windscreen” includes a windshield;

#### Textual Amendments

- F216** Reg. 32(11A) inserted (1.1.2004) by The Road Vehicles (Construction and Use) (Amendment) (No. 5) Regulations 2003 (S.I. 2003/3145), regs. 1, 3
- F217** Reg. 32(12A)-(12C) inserted (1.1.1993) by The Road Vehicles (Construction and Use) (Amendment) (No. 7) Regulations 1992 (S.I. 1992/3088), regs. 1, 6(2)
- F218** Words in reg. 32(13) omitted (6.5.1987) by virtue of The Road Vehicles (Construction and Use) (Amendment) Regulations 1987 (S.I. 1987/676), regs. 1(2), 15(2)
- F219** Words in reg. 32(13) inserted (1.1.1993) by The Road Vehicles (Construction and Use) (Amendment) (No. 7) Regulations 1992 (S.I. 1992/3088), regs. 1, 7

#### Commencement Information

- I28** Reg. 32 in force at 11.8.1986, see reg. 1

#### <sup>F220</sup>Mirrors and other devices for indirect vision

**33.**—(1) Save as provided in [<sup>F221</sup>paragraphs (5) to (6H)], a motor vehicle (not being a road roller) which is of a class specified in an item in column 2 of the Table shall be fitted with such mirror or mirrors or other device for indirect vision, if any, as are specified in that item in column 3; and any mirror or other device for indirect vision which is fitted to such a vehicle shall, whether or not it is required to be fitted, comply with the requirements, if any, specified in that item in columns 4 and 5.

(2) Save as provided in paragraph (5), each exterior mirror with which a vehicle is required to be fitted in accordance with item 2 or 8 of the Table shall, if the vehicle has a technically permissible maximum weight (as mentioned in Annex 1 to Community Directive 71/127) exceeding 3500 kg, be a Class II mirror (as described in that Annex) and shall in any other case be a Class II or a Class III mirror (as described in that Annex).

**Status:** This revised version has been created from an electronic version contributed by Westlaw which was originally derived from the printed publication. **Read more** (See end of Document for details) **Changes to legislation:** There are currently no known outstanding effects for the The Road Vehicles (Construction and Use) Regulations 1986. (See end of Document for details)

(3) Save as provided in paragraph (5), in the case of a wheeled motor vehicle described in item 1, 2, 10 or 11 of the Table which is first used on or after 1st April 1969 the edges of any interior mirror shall be surrounded by some material such as will render it unlikely that severe cuts would be caused if the mirror or that material were struck by any occupant of the vehicle.

(4) Save as provided in paragraph (5), in the case of a motor vehicle falling within paragraph (a) in column 4 of items 1 and 7, or within item 8, of the Table—

- (a) each mirror shall be fixed to the vehicle in such a way that it remains steady under normal driving conditions;
- (b) each exterior mirror on a vehicle fitted with windows and a windscreen shall be visible to the driver, when in his driving position, through a side window or through the portion of the windscreen which is swept by the windscreen wiper;
- (c) where the bottom edge of an exterior mirror is less than 2 m above the road surface when the vehicle is laden, that mirror shall not project more than 20 cm beyond the overall width of the vehicle or, in a case where the vehicle is drawing a trailer which has an overall width greater than that of the drawing vehicle, more than 20 cm beyond the overall width of the trailer;
- (d) where the bottom edge of an exterior mirror, which complies with the requirements of Community Directive 2003/97 or 2005/27 or ECE Regulation 46.02, is less than 2 m above the road surface when the vehicle is laden, that mirror shall not project more than 25 cm beyond the overall width of the vehicle or, in the case where the vehicle is drawing a trailer which has an overall width greater than that of the drawing vehicle, more than 25 cm beyond the overall width of the trailer;
- (e) each interior mirror shall be capable of being adjusted by the driver when in his driving position; and
- (f) except in the case of a mirror which, if knocked out of its alignment, can be returned to its former position without needing to be adjusted, each exterior mirror on the driver's side of the vehicle shall be capable of being adjusted by the driver when in his driving position, but this requirement shall not prevent such a mirror from being locked into position from the outside of the vehicle.

(5) Instead of complying with paragraphs (1) to (4) a vehicle may comply—

- (a) if it is a goods vehicle with a maximum gross weight exceeding 3500 kg first used on or after 1st April 1985 and before 1st August 1989, with Community Directive 79/795, 85/205, 86/562 or 88/321 or ECE Regulation 46.01;
- (b) if it is a goods vehicle first used on or after 1st August 1989 and before 26th January 2007—
  - (i) in the case of a vehicle with a maximum gross weight exceeding 3500 kg but not exceeding 12,000 kg, with Community Directive 79/795, 85/205, 86/562 or 88/321 or ECE Regulation 46.01; and
  - (ii) in the case of a vehicle with a maximum gross weight exceeding 12,000 kg, with Community Directive 85/205, 86/562 or 88/321 or ECE Regulation 46.01;
- (c) if it is an agricultural motor vehicle, with Community Directive 71/127, 74/346, 79/795, 85/205, 86/562 or 88/321 or ECE Regulation 46.01;
- (d) if it is a two-wheeled motor cycle with or without a side-car, with Community Directive 71/127, 79/795, 80/780, 85/205, 86/562 or 88/321 or ECE Regulation 46.01; and
- (e) if it is any other vehicle, with Community Directive 71/127, 79/795, 85/205, 86/562 or 88/321 or ECE Regulation 46.01.

**Status:** Point in time view as at 31/03/2009.

**Status:** This revised version has been created from an electronic version contributed by Westlaw which was originally derived from the printed publication. **Read more** (See end of Document for details) **Changes to legislation:** There are currently no known outstanding effects for the The Road Vehicles (Construction and Use) Regulations 1986. (See end of Document for details)

(6) Instead of complying with the provisions of column 4 in items 3, 4, 7 or 8 of the Table a mirror may comply with the requirements as to construction and testing set out in—

- (a) Annex I to Community Directive 71/127, excluding paragraphs 2.3.4 and 2.6;
- (b) Annex I to Community Directive 79/795, excluding paragraphs 2.3.3 and 2.6;
- (c) Annex II to Community Directive 2003/97, excluding paragraph 3.4; or
- (d) Annex II to Community Directive 2005/27, excluding paragraph 3.4.

[<sup>F222</sup>(6A) The requirements set out in paragraph (1) and the Table are modified as set out in paragraphs (6C) and (6D) in so far as those requirements relate to a relevant vehicle and to the fitting of class IV and class V mirrors on the passenger’s side of that vehicle.

(6B) The alternative requirements set out in paragraph (5) do not apply in so far as those requirements relate to a relevant vehicle and to the fitting of class IV and class V mirrors on the passenger’s side of the vehicle.

(6C) Subject to paragraph (6F), a relevant vehicle which would otherwise be required to meet the requirements set out in item 3 of the Table shall instead meet the requirements set out in item 4 which are applicable to a vehicle of the same maximum gross weight.

(6D) Subject to paragraph (6F), a relevant vehicle which would otherwise be required to meet the requirements set out in item 5 of the Table shall instead meet the requirements set out in item 6.

(6E) For the purposes of paragraphs (6C) and (6D)—

- (a) the words “and other devices for indirect vision” are omitted from item 4; and
- (b) the words “or other devices for indirect vision” are omitted from items 4 and 6.

(6F) A relevant vehicle does not have to comply with paragraph (6C) or (6D) (whichever is applicable to the vehicle) in the circumstances set out in paragraph (6G) or (6H).

(6G) The first set of circumstances is where the vehicle is equipped in the manner described in article 3(2) of Community Directive 2007/38.

(6H) The second set of circumstances is where the vehicle cannot, for want of available, economically viable, technical solutions—

- (a) comply with paragraph (6C) or (6D) (whichever is applicable to the vehicle); or
- (b) be equipped in the manner described in article 3(2) of Community Directive 2007/38,

but is equipped in the manner described in article 3(3) of Community Directive 2007/38.]

(7) In this regulation—

- (a) “devices for indirect vision” mean devices to observe the traffic area adjacent to the vehicle which cannot be observed by direct vision and may include conventional mirrors, camera-monitors or other devices able to present information about the indirect field of vision to the driver;
- (b) “mirror” means any device with a reflecting surface, excluding devices such as periscopes, intended to give a clear view to the rear, side or front of the vehicle;
- (c) “interior mirror” means a device defined in sub-paragraph (a), which can be fitted in the passenger compartment of a vehicle;
- (d) “exterior mirror” means a device defined in sub-paragraph (a), which can be fitted on the external surface of a vehicle;

[<sup>F223</sup>(e) “class IV” and “class V”, in relation to mirrors, have the meanings given in point 1.1.1.14 of Annex I to Community Directive 2003/97; and

- (f) “a relevant vehicle” means a vehicle which—



**Status:** This revised version has been created from an electronic version contributed by Westlaw which was originally derived from the printed publication. **Read more** (See end of Document for details) **Changes to legislation:** There are currently no known outstanding effects for the The Road Vehicles (Construction and Use) Regulations 1986. (See end of Document for details)

- (i) would be a goods vehicle of a class referred to in column 2 of item 4 or 6 of the Table if “1st January 2000” were substituted for “26th January 2007”; and
- (ii) is not outside the scope of Community Directive 2007/38 by virtue of article 2(2) (b) or (c) of that Directive.]

(8) In the case of—

- (a) an agricultural motor vehicle, or
- (b) a vehicle described in items 2 or 8 in the Table,

when drawing a trailer the references to a vehicle in the definitions in paragraph (7) shall be construed as including references to that trailer.

[<sup>F224</sup>(9) Where a provision is applied by paragraph (6C) or (6D) to a vehicle which was first used on or after 1st January 2000, that provision applies to the vehicle whatever the date of manufacture of the vehicle, and regulation 4(2) is disapplied accordingly.]

#### TABLE

(regulation 33(1))

1 Item	2 Class of vehicle	3 Mirrors or other devices for indirect vision to be fitted	4 Requirements to be complied with by any mirrors fitted	5 Requirements to be complied with by any other devices for indirect vision where fitted
1	A motor vehicle which is— (a) drawing a trailer, if a person is carried on the trailer so that he has an uninterrupted view to the rear and has an efficient means of communicating to the driver the effect of signals given by the drivers of other vehicles to the rear; (b) (i) a works truck;	No requirement.	(a)	(a) If None the vehicle is a wheeled vehicle first used on or after 1st June 1978, Item 2 of Annex I to Community Directive 71/127 or 79/795 or Annex II to Community Directive 86/562

**Status:** Point in time view as at 31/03/2009.

**Status:** This revised version has been created from an electronic version contributed by Westlaw which was originally derived from the printed publication. **Read more** (See end of Document for details)**Changes to legislation:** There are currently no known outstanding effects for the The Road Vehicles (Construction and Use) Regulations 1986. (See end of Document for details)

1 Item	2 Class of vehicle	3 Mirrors or other devices for indirect vision to be fitted	4 Requirements to be complied with by any mirrors fitted	5 Requirements to be complied with by any other devices for indirect vision where fitted
	(ii) a track-laying agricultural motor vehicle; and		or 88/321 or paragraphs 4 to 8 of ECE Regulation 46.01	
	(iii) a wheeled agricultural motor vehicle first used before 1st June 1978, if, in each case, the driver can easily obtain a view to the rear;		(b) In other cases, none, except as specified in paragraph (3).	
	(c) a pedestrian-controlled vehicle;			
	(d) a chassis being driven from the place where it has been manufactured to the place where it is to receive a vehicle body; or			

1 Item	2 Class of vehicle	3 Mirrors or other devices for indirect vision to be fitted	4 Requirements to be complied with by any mirrors fitted	5 Requirements to be complied with by any other devices for indirect vision where fitted
	(e) an agricultural motor vehicle which has an unladen weight exceeding 7370 kg and which— (i) is a track-laying vehicle or (ii) is a wheeled vehicle first used before 1st June 1978.			
2.	A motor vehicle not included in item 1, which is— (a) a wheeled locomotive or a wheeled motor tractor first used in either case on or after 1st June 1978; (b) an agricultural motor vehicle, not being a	At least one exterior mirror fitted on the offside.	None, except as specified in paragraphs (2) and (3).	None.

**Status:** Point in time view as at 31/03/2009.

**Status:** This revised version has been created from an electronic version contributed by Westlaw which was originally derived from the printed publication. **Read more** (See end of Document for details)**Changes to legislation:** There are currently no known outstanding effects for the The Road Vehicles (Construction and Use) Regulations 1986. (See end of Document for details)

1 Item	2 Class of vehicle	3 Mirrors or other devices for indirect vision to be fitted	4 Requirements to be complied with by any mirrors fitted	5 Requirements to be complied with by any other devices for indirect vision where fitted
	track-laying vehicle with an unladen weight not exceeding 7370 kg (which falls in item 11) or a wheeled agricultural motor vehicle first used after 1st June 1986 which is driven at more than 20 mph (which falls in item 8); or (c) a works truck.			
3.	A wheeled motor vehicle not included in items 1 or 4 first used on or after 1st April 1983 which is— (a) a bus; or (b) a goods vehicle with a maximum gross weight exceeding 3500 kg (not being	Mirrors complying with item 3 of Annex I to Community Directive 79/795 or with paragraph 2.1 of Annex III to Community Directive 86/562 or 88/321 or paragraph 16.2.1 of ECE Regulation 46.01 or, except in the case of a goods vehicle first used on or after 1st April 1985, mirrors as required in	Item 2 of Annex I to Community Directive 71/127 or 79/795 or Annex II to Community Directive 86/562 or 88/321 or paragraphs 4 to 8 of ECE Regulation 46.01.	None.

1 Item	2 Class of vehicle	3 Mirrors or other devices for indirect vision to be fitted	4 Requirements to be complied with by any mirrors fitted	5 Requirements to be complied with by any other devices for indirect vision where fitted
	<p>an agricultural motor vehicle or one which is not driven at more than 20 mph) other than a vehicle described in item 5.</p>	<p>the entry in this column in item 8.</p>		
4.	<p>A wheeled motor vehicle not included in item 1 first used on or after 26th January 2007 which is—</p> <p>(a) a bus;</p> <p>(b) a goods vehicle with a maximum gross weight—</p> <p>(i) exceeding 3500 kg but not exceeding 7500 kg;</p> <p>or</p> <p>(ii) exceeding 7500 kg but</p>	<p>(a) and (b)(ii) Mirrors and other devices for indirect vision complying with Annex III to Community Directive 2003/97 or 2005/27 or paragraph 15 of ECE Regulation 46.02.</p> <p>(b)(i) Mirrors or other devices for indirect vision complying with Community Directive 2003/97 or 2005/27.</p>	<p>Paragraph 6 of Annex I and Annex II to Community Directive 2003/97 or 2005/27 or paragraphs 4, 5 and 6.1 of ECE Regulation 46.02.</p>	<p>Part B of Annex II to Community Directive 2003/97 or paragraph 4, 5 and 6.2 of ECE Regulation 46.02.</p>

**Status:** Point in time view as at 31/03/2009.

**Status:** This revised version has been created from an electronic version contributed by Westlaw which was originally derived from the printed publication. **Read more** (See end of Document for details)**Changes to legislation:** There are currently no known outstanding effects for the The Road Vehicles (Construction and Use) Regulations 1986. (See end of Document for details)

1 Item	2 Class of vehicle	3 Mirrors or other devices for indirect vision to be fitted	4 Requirements to be complied with by any mirrors fitted	5 Requirements to be complied with by any other devices for indirect vision where fitted
		not exceeding 12,000 kg;		
	(not being an agricultural motor vehicle or one which is not driven at more than 20 mph).			
5.	A goods vehicle not being an agricultural motor vehicle with a maximum gross weight exceeding 12,000 kg which is first used on or after 1st October 1988 and before 26th January 2007.	Mirrors complying with paragraph 2.1 of Annex III to Community Directive 86/562 or 88/321 or paragraph 16.2.1 of ECE Regulation 46.01.	Annex II to Community Directive 86/562 or 88/321 or paragraphs 4 to 8 of ECE Regulation 46.01.	None
6.	A goods vehicle not being an agricultural motor vehicle with a maximum gross weight exceeding 12,000 kg which is first used on or after 26th January 2007.	Mirrors or other devices for indirect vision complying with Annex III to Community Directive 2003/97 or 2005/27 or paragraph 15 of ECE Regulation 46.02.	Paragraph 6 of Annex I and Annex II to Community Directive 2003/97 or 2005/27 or paragraphs 4, 5 and 6.1 of ECE Regulation 46.02.	Part B of Annex II to Community Directive 2003/97 or paragraph 4, 5 and 6.2 of ECE Regulation 46.02.
7.	A two-wheeled motor cycle with or without a sidecar attached.	No requirement.	(a) (a) If the vehicle is first used on or after 1st October 1978,	None.

**Status:** Point in time view as at 31/03/2009.

**Status:** This revised version has been created from an electronic version contributed by Westlaw which was originally derived from the printed publication. **Read more** (See end of Document for details)**Changes to legislation:** There are currently no known outstanding effects for the The Road Vehicles (Construction and Use) Regulations 1986. (See end of Document for details)

1 Item	2 Class of vehicle	3 Mirrors or other devices for indirect vision to be fitted	4 Requirements to be complied with by any mirrors fitted	5 Requirements to be complied with by any other devices for indirect vision where fitted
			Item 2 of Annex I to Community Directive 71/127, 79/795 or 80/780 or Annex II to Community Directive 86/562 or 88/321 or paragraphs 4 to 8 of ECE Regulation 46.01 and paragraph (4) of this regulation. (b) In other cases, none.	
8.	A wheeled motor vehicle not in items 1 to 7, which is first used on or after 1st June 1978 (or, in the case of a Ford Transit motor car, 10th July 1978) and before 26th January 2010.	(i) At least one exterior mirror fitted on the offside of the vehicle; and (ii) at least one interior mirror, unless a mirror so	Item 2 of Annex I to Community Directive 71/127 or 79/795 or Annex II to Community Directive 86/562 or 88/321 or paragraphs 4 to 8 of ECE Regulation 46.01 and paragraphs	None.

**Status:** Point in time view as at 31/03/2009.

**Status:** This revised version has been created from an electronic version contributed by Westlaw which was originally derived from the printed publication. **Read more** (See end of Document for details)**Changes to legislation:** There are currently no known outstanding effects for the The Road Vehicles (Construction and Use) Regulations 1986. (See end of Document for details)

1 Item	2 Class of vehicle	3 Mirrors or other devices for indirect vision to be fitted	4 Requirements to be complied with by any mirrors fitted	5 Requirements to be complied with by any other devices for indirect vision where fitted
		<p>fitted would give the driver no view to the rear of the vehicle; and</p> <p>(iii) at least one exterior mirror fitted on the nearside of the vehicle unless an interior mirror gives the driver an adequate view to the rear.</p>	(2) and (4) of this regulation.	
9.	A wheeled motor vehicle not in items 1 to 7, which is first used on or after 26th January 2010.	Mirrors complying with Annex III to Community Directive 2003/97 or 2005/27 or paragraph 15 of ECE Regulation 46.02.	Paragraph 6 of Annex I and Annex II to Community Directive 2003/97 or 2005/27 or paragraphs 4, 5 and 6.1 of ECE Regulation 46.02.	If fitted to comply with Part B of Annex II to Community Directive 2003/97 or paragraphs 4, 5 and 6.2 of ECE Regulation 46.02.
10.	A wheeled motor vehicle, not in items 1 to 7, first used before 1st June 1978 (or in the case of a Ford Transit motor car, 10th July 1978) and a track-laying motor vehicle which is not an agricultural motor vehicle first used on or after 1st January 1958,	At least one exterior mirror fitted on the offside of the vehicle and either one interior mirror or one exterior mirror fitted on the near-side of the vehicle.	None, except as specified in paragraph (3).	None.



**Status:** This revised version has been created from an electronic version contributed by Westlaw which was originally derived from the printed publication. **Read more** (See end of Document for details)**Changes to legislation:** There are currently no known outstanding effects for the The Road Vehicles (Construction and Use) Regulations 1986. (See end of Document for details)

1 Item	2 Class of vehicle	3 Mirrors or other devices for indirect vision to be fitted	4 Requirements to be complied with by any mirrors fitted	5 Requirements to be complied with by any other devices for indirect vision where fitted
	which in either case is— (a) a bus; (b) a dual-purpose vehicle; or (c) a goods vehicle.			
11.	A motor vehicle, whether wheeled or track-laying, not in items 1 to 10.	At least one interior or exterior mirror.	None, except as specified in paragraph (3).	None.]

#### Textual Amendments

**F220** Reg. 33 substituted (12.12.2005) by The Road Vehicles (Construction and Use)(Amendment)(No. 4) Regulations 2005 (S.I. 2005/3165), reg. 1, **Sch.**

**F221** Words in reg. 33(1) substituted (31.3.2009) by The Road Vehicles (Construction and Use) (Amendment) Regulations 2009 (S.I. 2009/142), regs. 1(2), **3(2)**

**F222** Reg. 33(6A)-(6H) inserted (31.3.2009) by The Road Vehicles (Construction and Use) (Amendment) Regulations 2009 (S.I. 2009/142), regs. 1(2), **3(3)**

**F223** Reg. 33(7)(e)(f) added (31.3.2009) by The Road Vehicles (Construction and Use) (Amendment) Regulations 2009 (S.I. 2009/142), regs. 1(2), **3(4)**

**F224** Reg. 33(9) added (31.3.2009) by The Road Vehicles (Construction and Use) (Amendment) Regulations 2009 (S.I. 2009/142), regs. 1(2), **3(5)**

#### Commencement Information

**I29** Reg. 33 in force at 11.8.1986, see **reg. 1**

### Windscreen wipers and washers

**34.**—(1) Subject to paragraphs (4) and (5), every vehicle fitted with a windscreen shall, unless the driver can obtain an adequate view to the front of the vehicle without looking through the windscreen, be fitted with one or more efficient automatic windscreen wipers capable of clearing the windscreen so that the driver has an adequate view of the road in front of both sides of the vehicle and to the front of the vehicle.

(2) Save as provided in paragraphs (3), (4) and (5), every wheeled vehicle required by paragraph (1) to be fitted with a wiper or wipers shall also be fitted with a windscreen washer capable of cleaning, in conjunction with the windscreen wiper, the area of the windscreen swept by the wiper of mud or similar deposit.

(3) The requirement specified in paragraph (2) does not apply in respect of—

**Status:** Point in time view as at 31/03/2009.

**Status:** This revised version has been created from an electronic version contributed by Westlaw which was originally derived from the printed publication. **Read more** (See end of Document for details)**Changes to legislation:** There are currently no known outstanding effects for the The Road Vehicles (Construction and Use) Regulations 1986. (See end of Document for details)

- (a) an agricultural motor vehicle (other than a vehicle first used on or after 1st June 1986 which is driven at more than 20 mph);
  - (b) a track-laying vehicle;
  - (c) a vehicle having a maximum speed not exceeding 20 mph; or
  - (d) a vehicle being used to provide a local service, as defined in the Transport Act 1985.
- (4) Instead of complying with paragraphs (1) and (2), a vehicle may comply with Community Directive 78/318.
- (5) Instead of complying with paragraph (1) an agricultural motor vehicle may comply with Community Directive 79/1073.
- (6) Every wiper and washer fitted in accordance with this regulation shall at all times while a vehicle is being used on a road be maintained in efficient working order and be properly adjusted.

#### Commencement Information

**I30** Reg. 34 in force at 11.8.1986, see [reg. 1](#)

## F

### INSTRUMENTS AND EQUIPMENT

#### Speedometers

**35.**—(1) Save as provided in paragraphs (2) and (3), every motor vehicle shall be fitted with a speedometer which, if the vehicle is first used on or after 1st April 1984, shall be capable of indicating speed in both miles per hour and kilometres per hour, either simultaneously or, by the operation of a switch, separately.

(2) Paragraph (1) does not apply to—

- (a) a vehicle having a maximum speed not exceeding 25 mph;
- (b) a vehicle which it is at all times unlawful to drive at more than 25 mph;
- (c) an agricultural motor vehicle which is not driven at more than 20 mph;
- (d) a motor cycle first used before 1st April 1984 the engine of which has a cylinder capacity not exceeding 100 cc;
- (e) an invalid carriage first used before 1st April 1984;
- (f) a works truck first used before 1st April 1984;
- (g) a vehicle first used before 1st October 1937; or
- (h) a vehicle equipped with recording equipment marked with a marking designated as an approval mark by regulation 5 of the Approval Marks Regulations and shown at item 3 in Schedule 4 to those Regulations (whether or not the vehicle is required to be equipped with that equipment) and which, as regards the visual indications given by that equipment of the speed of the vehicle, complies with the requirements relating to the said indications and installations specified in the Community Recording Equipment Regulation.

(3) Instead of complying with paragraph (1) a vehicle may comply with <sup>F225</sup>Community Directive 97/39] or with ECE Regulation 39.

**Status:** This revised version has been created from an electronic version contributed by Westlaw which was originally derived from the printed publication. **Read more** (See end of Document for details)**Changes to legislation:** There are currently no known outstanding effects for the The Road Vehicles (Construction and Use) Regulations 1986. (See end of Document for details)

#### Textual Amendments

**F225** Words in [reg. 35\(3\)](#) substituted (1.6.1998) by [The Road Vehicles \(Construction and Use\) \(Amendment\) \(No. 3\) Regulations 1998 \(S.I. 1998/1188\)](#), regs. 1, **11**

#### Commencement Information

**I31** [Reg. 35](#) in force at 11.8.1986, see [reg. 1](#)

### Maintenance of speedometers

**36.**—(1) Every instrument for indicating speed fitted to a motor vehicle—

- (a) in compliance with the requirements of regulation 35(1) or (3); or
- (b) to which regulation 35(2)(h) relates and which is not, under the Community Recording Equipment Regulation, required to be equipped with the recording equipment mentioned in that paragraph,

shall be kept free from any obstruction which might prevent its being easily read and shall at all material times be maintained in good working order.

(2) In this regulation “all material times” means all times when the motor vehicle is in use on a road except when—

- (a) the vehicle is being used on a journey during which, as a result of a defect, the instrument ceased to be in good working order; or
- (b) as a result of a defect, the instrument has ceased to be in good working order and steps have been taken to have the vehicle equipped with all reasonable expedition, by means of repairs or replacement, with an instrument which is in good working order.

#### Commencement Information

**I32** [Reg. 36](#) in force at 11.8.1986, see [reg. 1](#)

### Speed limiters

<sup>F226</sup>**36A.**—(1) Subject to paragraph (13), this regulation applies to every coach which—

- (a) was first used on or after 1st April 1974 and before 1st January 1988; and
- (b) has, or if a speed limiter were not fitted to it would have, a maximum speed exceeding <sup>F227</sup>112.65 km/h; and a reference to this regulation to a paragraph (1) vehicle is a reference to a vehicle to which this regulation applies by virtue of this paragraph.

(2) Subject to paragraph (13), this regulation also applies to every bus which—

- (a) is first used on or after 1st January 1988;
- (b) has a maximum gross weight exceeding 7.5 tonnes; and
- (c) has, or if a speed limiter were not fitted to it would have, a maximum speed exceeding <sup>F228</sup>100 km/h; and a reference in this regulation to a paragraph (2) vehicle is a reference to a vehicle to which this regulation applies by virtue of this paragraph.

<sup>F229</sup>(2A) Subject to paragraph (13), this regulation also applies to every bus, not being a bus to which paragraph (2) applies, which—

- (a) is first used on or after 1st January 2005;

**Status:** Point in time view as at 31/03/2009.

**Status:** This revised version has been created from an electronic version contributed by Westlaw which was originally derived from the printed publication. **Read more** (See end of Document for details)**Changes to legislation:** There are currently no known outstanding effects for the The Road Vehicles (Construction and Use) Regulations 1986. (See end of Document for details)

- (b) has a maximum gross weight exceeding 5 tonnes but not exceeding 10 tonnes; and
- (c) has, or if a speed limiter were not fitted to it would have, a maximum speed exceeding 100 km/h;

and a reference in this regulation to a paragraph (2A) vehicle is a reference to a vehicle to which this regulation applies by virtue of this paragraph.

(2B) Subject to <sup>F230</sup>paragraph (13)], this regulation also applies to every bus which—

- (a) is first used on or after 1st January 2005;
- (b) has a maximum gross weight not exceeding 5 tonnes; and
- (c) has, or if a speed limiter were not fitted to it would have, a maximum speed exceeding 100 km/h;

and a reference in this regulation to a paragraph (2B) vehicle is a reference to a vehicle to which this regulation applies by virtue of this paragraph.

(2C) Subject to <sup>F231</sup>paragraph (13)], this regulation also applies to every bus, not being a bus to which paragraph (2) applies, which—

- (a) was first used on or after 1st October 2001 and before 1st January 2005;
- <sup>F232</sup>(b) complies with the limit values in respect of Euro III emission standards set out in Council Directive 88/77/EEC, as amended by amendments up to and including those effected by Commission Directive 2001/27/EC;]
- (c) has a maximum gross weight not exceeding 10 tonnes; and
- (d) has, or if a speed limiter were not fitted to it would have, a maximum speed exceeding 100 km/h;

and a reference in this regulation to a paragraph (2C) vehicle is a reference to a vehicle to which this regulation applies by virtue of this paragraph.]

<sup>F233</sup>(2D) .....

<sup>F233</sup>(2E) .....

<sup>F234</sup>(3) .....

(4) Every vehicle to which this regulation applies shall be fitted with a speed limiter in respect of which such of the requirements of paragraphs (5) to (9) are met as apply to that speed limiter.

(5) Subject to paragraph (10), the requirements of this paragraph are that a speed limiter fitted to any vehicle must—

- (a) be sealed by an authorised sealer in such a manner as to protect the limiter against any improper interference or adjustment and against any interruption of its power supply; and
- (b) be maintained in good and efficient working order.

(6) The requirements of this paragraph are that a speed limiter fitted to a paragraph (1) vehicle must be calibrated to a set speed not exceeding <sup>F235</sup>112.65 km/h].

<sup>F236</sup>(7) Subject to paragraph (7A), the requirements of this paragraph are that a speed limiter fitted to a paragraph (2) vehicle, a paragraph (2A) vehicle, a paragraph (2B) vehicle or a paragraph 2(C) vehicle, must be set so that the speed of the vehicle cannot exceed 100 km/h.]

<sup>F237</sup>(7A) A speed limiter fitted to a paragraph (2) vehicle which—

- (a) was first used before 1st January 2005 and has a maximum gross weight exceeding 10 tonnes; or
- (b) was first used before 1st October 2001 and has a maximum gross weight exceeding 7.5 tonnes but not exceeding 10 tonnes;

may be set at a maximum speed of 100 km/h.]

(8) Subject to paragraphs (11) and (12), the requirements of this paragraph are that a speed limiter fitted at any time to any paragraph (1) vehicle or a speed limiter fitted before 1st October 1994 to a paragraph (2) vehicle first used before that date must comply with—

- (a) Part 1 of the British Standard; or
- (b) the Annexes to Community Directive 92/24 [F238] as amended by Directive 2004/11/EC of the European Parliament and of the Council].

(9) The requirements of this paragraph are that a speed limiter (not being a speed limiter to which paragraph (8) applies) fitted to a paragraph (2) vehicle [F239], a paragraph (2A) vehicle, a paragraph (2B) vehicle and a paragraph (2C) vehicle] must comply with the Annexes to Community Directive 92/24 [F240] as amended by Directive 2004/11/EC of the European Parliament and of the Council].

[F241] (9A) .....

(10) Paragraph (5)(a) shall have effect in relation to—

- (a) a speed limiter fitted before 1st August 1992 to a vehicle first used before that date; or
- (b) a speed limiter sealed outside the United Kingdom, as if the words “by an authorised sealer” were omitted.

(11) Paragraph (8) does not apply to a speed limiter fitted before 1st October 1988.

(12) Paragraph (8) does not apply to a speed limiter fitted to a vehicle if the speed limiter complies with an equivalent standard.

(13) This regulation does not apply to a vehicle—

- (a) being taken to a place where a speed limiter is to be installed, calibrated, repaired or replaced; [F242] ...
- (b) completing a journey in the course of which the speed limiter has accidentally ceased to function;
- [F243] (c) which is owned by the Secretary of State for Defence and used for naval, military or air force purposes;
- (d) which is used for naval, military or air force purposes while being driven by a person for the time being subject to the orders of a member of the armed forces of the Crown; [F244] ...
- (e) while it is being used for fire and rescue authority purposes or for or in connection with the exercise of any function of a relevant authority as defined in section 6 of the Fire (Scotland) Act 2005, for ambulance purposes or police purposes [F245]; or
- (f) which is operated by or on behalf of Her Majesty’s Prison Service and used primarily for the purpose of moving Category A prisoners.]

(14) In this regulation

“authorised sealer” has the meaning given in Schedule 3B;

[F246] “Category A prisoners” means that prison security category which is applied to prisoners whose escape would be highly dangerous to the public or the police or to the security of the state, no matter how unlikely that escape might be, and for whom the aim must be to make escape impossible;]

“equivalent standard” means—

- (a) a standard or code of practice of a national standards body or equivalent body of any member State;
- (b) any international standard recognised for use as a standard by any member State; or

**Status:** Point in time view as at 31/03/2009.

**Status:** This revised version has been created from an electronic version contributed by Westlaw which was originally derived from the printed publication. **Read more** (See end of Document for details)**Changes to legislation:** There are currently no known outstanding effects for the The Road Vehicles (Construction and Use) Regulations 1986. (See end of Document for details)

- (c) a technical specification or code of practice which, whether mandatory or not, is recognised for use as a standard by a public authority of any member State, where the standard, code of practice, international standard or technical specification provides, in relation to speed limiters, a level of speed control equivalent to that provided by Part 1 of the British Standard;

[<sup>F247</sup>“Euro III emission standards” means the emission limits given in rows A of the tables in section 6.2.1 of Annex 1 to Directive 1999/96/EC of the European Parliament and of the Council (amending Council Directive 88/77/EEC);]

[<sup>F248</sup>“international transport operations” means transport operations outside the United Kingdom;]

[<sup>F248</sup>“national transport operations” means transport operations within the United Kingdom;]

“Part 1 of the British Standard” means the British Standard for Maximum Road Speed Limiters for Motor Vehicles which was published by the British Standards Institution under the number BS AU 217: Part 1: 1987 and which came into effect on 29th May 1987; as amended by Amendment Slip No.1 under the number AMD 5969 which was published and came into effect on 30th June 1988;

“set speed”, in relation to a calibrated speed limiter fitted to a vehicle, means the speed intended by the person who calibrated the speed limiter to be the mean speed of the vehicle when operating in a stabilised condition;

“speed limiter” means a device designed to limit the maximum speed of a motor vehicle by controlling the power output from the engine of the vehicle

<sup>F249</sup> ...

[<sup>F248</sup>“transport operations” means the transportation of passengers in vehicles designed for such a purpose and to which this regulation applies.]]

### Textual Amendments

- F226** Regs. 36A, 36B substituted (1.1.1994) by The Road Vehicles (Construction and Use) (Amendment) (No. 3) Regulations 1993 (S.I. 1993/3048), regs. 1, 3(1), **Sch. Pt. I**
- F227** Word in reg. 36A(1)(b) substituted (1.7.1998) by The Road Vehicles (Construction and Use) (Amendment) (No. 3) Regulations 1997 (S.I. 1997/1340), regs. 1, **3(2)**
- F228** Word in reg. 36A(2)(c) substituted (1.7.1998) by The Road Vehicles (Construction and Use) (Amendment) (No. 3) Regulations 1997 (S.I. 1997/1340), regs. 1, **3(3)**
- F229** Reg. 36A(2A)-(2E) added (1.1.2005) by The Road Vehicles (Construction and Use) (Amendment) (No.2) Regulations 2004 (S.I. 2004/2102), regs. 1, **3(2)**
- F230** Words in reg. 36A(2B) substituted (3.3.2009) by The Road Vehicles (Construction and Use) (Amendment) Regulations 2009 (S.I. 2009/142), regs. 1(2), **4(2)**
- F231** Words in reg. 36A(2C) substituted (3.3.2009) by The Road Vehicles (Construction and Use) (Amendment) Regulations 2009 (S.I. 2009/142), regs. 1(2), **4(3)**
- F232** Reg. 36A(2C)(b) substituted (12.12.2005) by The Road Vehicles (Construction and Use)(Amendment) (No. 5) Regulations 2005 (S.I. 2005/3170), regs. 1, **3(2)**
- F233** Reg. 36A(2D)(2E) omitted (3.3.2009) by virtue of The Road Vehicles (Construction and Use) (Amendment) Regulations 2009 (S.I. 2009/142), regs. 1(2), **4(4)**
- F234** Reg. 36A(3) omitted (1.7.1998) by virtue of The Road Vehicles (Construction and Use) (Amendment) (No. 3) Regulations 1997 (S.I. 1997/1340), regs. 1, **3(4)**
- F235** Word in reg. 36A(6) substituted (1.7.1998) by The Road Vehicles (Construction and Use) (Amendment) (No. 3) Regulations 1997 (S.I. 1997/1340), regs. 1, **3(5)**
- F236** Reg. 36A(7) substituted (1.1.2005) by The Road Vehicles (Construction and Use) (Amendment) (No.2) Regulations 2004 (S.I. 2004/2102), regs. 1, **3(3)**

**Status:** This revised version has been created from an electronic version contributed by Westlaw which was originally derived from the printed publication. **Read more** (See end of Document for details)**Changes to legislation:** There are currently no known outstanding effects for the The Road Vehicles (Construction and Use) Regulations 1986. (See end of Document for details)

- F237** Reg. 36A(7A) substituted (12.12.2005) by The Road Vehicles (Construction and Use)(Amendment) (No. 5) Regulations 2005 (S.I. 2005/3170), regs. 1, **3(3)**
- F238** Words in reg. 36A(8)(b) added (1.1.2005) by The Road Vehicles (Construction and Use) (Amendment) (No.2) Regulations 2004 (S.I. 2004/2102), regs. 1, **3(5)**
- F239** Words in reg. 36A(9) added (1.1.2005) by The Road Vehicles (Construction and Use) (Amendment) (No.2) Regulations 2004 (S.I. 2004/2102), regs. 1, **3(6)(a)**
- F240** Words in reg. 36A(9) added (1.1.2005) by The Road Vehicles (Construction and Use) (Amendment) (No.2) Regulations 2004 (S.I. 2004/2102), regs. 1, **3(6)(b)**
- F241** Reg. 36A(9A) omitted (1.9.2003) by virtue of The Road Vehicles (Construction and Use) (Amendment) (No. 3) Regulations 2003 (S.I. 2003/1946), regs. 1, **4**
- F242** Word in reg. 36A(13) omitted (12.12.2005) by virtue of The Road Vehicles (Construction and Use) (Amendment)(No. 5) Regulations 2005 (S.I. 2005/3170), regs. 1, **3(4)(a)**
- F243** Reg. 36A(13)(c)-(e) added (12.12.2005) by The Road Vehicles (Construction and Use)(Amendment) (No. 5) Regulations 2005 (S.I. 2005/3170), regs. 1, **3(4)(b)**
- F244** Word in reg. 36A(13) omitted (3.3.2009) by virtue of The Road Vehicles (Construction and Use) (Amendment) Regulations 2009 (S.I. 2009/142), regs. 1(2), **4(5)(a)**
- F245** Reg. 36A(13)(f) and word inserted (3.3.2009) by The Road Vehicles (Construction and Use) (Amendment) Regulations 2009 (S.I. 2009/142), regs. 1(2), **4(5)(b)**
- F246** Words in reg. 36A(14) inserted (3.3.2009) by The Road Vehicles (Construction and Use) (Amendment) Regulations 2009 (S.I. 2009/142), regs. 1(2), **4(6)**
- F247** Words in reg. 36A(14) added (12.12.2005) by The Road Vehicles (Construction and Use)(Amendment) (No. 5) Regulations 2005 (S.I. 2005/3170), regs. 1, **3(5)**
- F248** Words in reg. 36A(14) added (1.1.2005) by The Road Vehicles (Construction and Use) (Amendment) (No.2) Regulations 2004 (S.I. 2004/2102), regs. 1, **3(7)**
- F249** Words in reg. 36A(14) omitted (1.7.1998) by virtue of The Road Vehicles (Construction and Use) (Amendment) (No. 3) Regulations 1997 (S.I. 1997/1340), regs. 1, **3(8)**

**[<sup>F226</sup>36B.**—(1) Subject to [<sup>F250</sup>paragraph (14)], this regulation applies to every motor vehicle [<sup>F251</sup>, not being a motor vehicle to which paragraph (1B) applies,] which—

- (a) is a goods vehicle;
- (b) has a maximum gross weight exceeding 7,500 kg but not exceeding 12,000 kg;
- (c) is first used on or after 1st August 1992 [<sup>F252</sup>and before 1st January 2005]; and
- (d) has, or if a speed limiter were not fitted to it would have, a relevant speed exceeding 60 mph; and a reference in this regulation to a paragraph (1) vehicle is a reference to a vehicle to which this regulation applies by virtue of this paragraph.

**[<sup>F253</sup>(1A)** Subject to [<sup>F254</sup>paragraph (14)], this regulation also applies to every motor vehicle which—

- (a) is a goods vehicle;
- (b) has a maximum gross weight exceeding 3,500 kg but not exceeding 12,000 kg;
- (c) is first used on or after 1st January 2005; and
- (d) has, or if a speed limiter were not fitted to it would have, a relevant speed exceeding 90 km/h;

and a reference in this regulation to a paragraph (1A) vehicle is a reference to a vehicle to which this regulation applies by virtue of this paragraph.

**[<sup>F255</sup>(1B)** Subject to [<sup>F256</sup>paragraph (14)], this regulation also applies to every motor vehicle, <sup>F257</sup>... which—

- (a) is a goods vehicle;

**Status:** Point in time view as at 31/03/2009.

**Status:** This revised version has been created from an electronic version contributed by Westlaw which was originally derived from the printed publication. **Read more** (See end of Document for details)**Changes to legislation:** There are currently no known outstanding effects for the The Road Vehicles (Construction and Use) Regulations 1986. (See end of Document for details)

- (b) has a maximum gross weight exceeding 3,500 kg but not exceeding 12,000 kg;
- (c) was first used on or after 1st October 2001 and before 1st January 2005;
- (d) complies with the limit values in respect of Euro III emission standards set out in Council Directive 88/77/EEC, as amended by amendments up to and including those effected by Commission Directive 2001/27/EC; and
- (e) has, or if a speed limiter were not fitted to it would have, a relevant speed exceeding 90km/h;

and a reference in this regulation to a paragraph (1B) vehicle is a reference to a vehicle to which this regulation applies by virtue of this paragraph.]]

<sup>F258</sup>(1C) .....

<sup>F258</sup>(1D) .....

(2) Subject to [<sup>F259</sup>paragraph (14)], this regulation also applies to every vehicle which—

- (a) is a goods vehicle;
- (b) has a maximum gross weight exceeding 12,000 kg;
- (c) is first used on or after 1st January 1988; and
- (d) has, or if a speed limiter were not fitted to it would have, a relevant speed exceeding [<sup>F260</sup>90 km/h]; and a reference in this regulation to a paragraph (2) vehicle is a reference to a vehicle to which this regulation applies by virtue of this paragraph.

<sup>F261</sup>(3) .....

<sup>F261</sup>(4) .....

<sup>F261</sup>(5) .....

(6) Every vehicle to which this regulation applies shall be fitted with a speed limiter in respect of which such of the requirements of paragraphs (7) to (11) are met as apply to that speed limiter.

(7) Subject to paragraph (12), the requirements of this paragraph are that a speed limiter fitted to any vehicle must—

- (a) be sealed by an authorised sealer in such a manner as to protect the limiter against any improper interference or adjustment or against any interruption of its power supply; and
- (b) be maintained in good and efficient working order.

(8) The requirements of this paragraph are that a speed limiter fitted to a paragraph (1) vehicle <sup>F262</sup>... must be calibrated to a set speed not exceeding 60 mph.

[<sup>F263</sup>(9) <sup>F264</sup>... the requirements of this paragraph are that a speed limiter fitted to [<sup>F265</sup>a paragraph (1A) vehicle, a paragraph (1B) vehicle or] a paragraph (2) vehicle must be set [<sup>F266</sup>so that] the stabilised speed of the vehicle must not exceed 90 km/h.]

(10) Subject to paragraph (13), the requirements of this paragraph are that a speed limiter fitted at any time to a paragraph (1) vehicle, a speed limiter fitted before 1st October 1994 to a paragraph (2) vehicle first used before that date <sup>F267</sup>... must comply with—

- (a) Part 1 of the British Standard; or
- (b) the Annexes to Community Directive 92/24 [<sup>F268</sup>as amended by Directive 2004/11/EC of the European Parliament and of the Council].

(11) The requirements of this paragraph are that a speed limiter (not being a speed limiter to which paragraph (10) applies) fitted to [<sup>F269</sup>a paragraph (1A) vehicle, a paragraph (1B) vehicle and] a paragraph (2) vehicle must comply with the Annexes to Community Directive 92/24 [<sup>F270</sup>as amended by Directive 2004/11/EC of the European Parliament and of the Council].



<sup>F271</sup>(11A) .....

(12) Paragraph (7)(a) shall have effect in relation to—

- (a) a speed limiter fitted before 1st August 1992 to a vehicle first used before that date; or
- (b) a speed limiter sealed outside the United Kingdom, as if the words “by an authorised sealer” were omitted.

<sup>F272</sup>(12A) .....

(13) Paragraph (10) does not apply to a speed limiter fitted to a vehicle if the speed limiter complies with an equivalent standard.

(14) This regulation does not apply to a vehicle—

- (a) which is being taken to a place where a speed limiter is to be installed, calibrated, repaired or replaced;
- (b) which is completing a journey in the course of which the speed limiter has accidentally ceased to function;
- (c) is owned by the Secretary of State for Defence and used for naval, military or air force purposes;
- (d) is used for naval, military or air force purposes while being driven by a person for the time being subject to the orders of a member of the armed forces of the Crown;
- (e) while it is being used for [<sup>F273</sup>fire brigade][<sup>F273</sup>relevant authority (as defined in section 6 of the Fire (Scotland) Act 2005 (asp 5))][<sup>F274</sup>or, in England or Wales, fire and rescue authority][<sup>F275</sup>or, in England, fire and rescue authority], ambulance or police purposes;  
<sup>F276</sup> ...

[<sup>F277</sup>(f) at a time when it is being used on a public road during any calendar week if—

- (i) it is being used only in passing from land in the occupation of the person keeping the vehicle to other land in his occupation, and
- (ii) it has not been used on public roads for distances exceeding an aggregate of six miles in that calendar week,

and for the purposes of this paragraph “public road” has the meaning given in section 62(1) the Vehicle Excise and Registration Act 1994[<sup>F278</sup>], or

- (g) which is an emergency tactical response vehicle operated by or on behalf of Her Majesty’s Prison Service and used primarily for the purpose of transporting people or equipment (or both) to restore order within Her Majesty’s prisons or immigration detention centres.]

(15) In this regulation

“equivalent standard”, “Part 1 of the British Standard”, <sup>F279</sup>... “speed limiter” and “stabilised speed” have the same meanings as in regulation 36A;

[<sup>F280</sup>“Euro III emission standards” means the emission limits given in rows A of the tables in section 6.2.1 of Annex 1 to Directive 1999/96/EC of the European Parliament and of the Council (amending Council Directive 88/77/EEC);]

[<sup>F281</sup>“international transport operations” means transport operations outside the United Kingdom;]

[<sup>F281</sup>“national transport operations” means transport operations within the United Kingdom;]

<sup>F282</sup> ... “relevant speed” means a speed which a vehicle is incapable, by means of its construction, of exceeding on the level under its own power when unladen

**Status:** Point in time view as at 31/03/2009.

**Status:** This revised version has been created from an electronic version contributed by Westlaw which was originally derived from the printed publication. **Read more** (See end of Document for details)**Changes to legislation:** There are currently no known outstanding effects for the The Road Vehicles (Construction and Use) Regulations 1986. (See end of Document for details)

[<sup>F283</sup>“set speed”, in relation to a paragraph (1) vehicle, has the same meaning as in regulation 36A; and

<sup>F284</sup> ... “set” in relation to a speed limiter fitted to [<sup>F285</sup>a paragraph (1A) vehicle, a paragraph (1B) vehicle and] a paragraph (2) vehicle, has the same meaning as in Community Directive 92/6; and references to the speed at which a speed limiter is set shall be construed accordingly];

[<sup>F281</sup>“transport operations” means the transportation of goods in vehicles designed for such a purpose and to which this regulation applies.]

(16) For the purposes of this regulation, a motor vehicle has a maximum gross trailer weight exceeding 5,000 kg if—

- (a) in the case of a vehicle equipped with a Ministry plate in accordance with regulation 70, the difference between its maximum gross weight and the relevant train weight exceeds 5,000 kg;
- (b) in the case of a vehicle not equipped with a Ministry plate, but which is equipped with a plate in accordance with regulation 66, the difference between its maximum gross weight and the weight shown on the plate in respect of item 8 of Part I of Schedule 8 exceeds 5,000 kg; and
- (c) in the case of any other vehicle, the vehicle is designed or adapted to be capable of drawing a trailer with a laden weight exceeding 5,000 kg when travelling on a road; and in subparagraph (a) “the relevant train weight” is the train weight shown in column (3) of the plate or, if no such weight is shown, the train weight shown in column (2) of the plate (where the plate is in the form required by [<sup>F286</sup>Schedule 10 or 10B]) or in column (4) of the plate (where the plate is in the form required by [<sup>F286</sup>Schedule 10A or 10C]).]

#### Textual Amendments

- F226** Regs. 36A, 36B substituted (1.1.1994) by The Road Vehicles (Construction and Use) (Amendment) (No. 3) Regulations 1993 (S.I. 1993/3048), regs. 1, 3(1), **Sch. Pt. I**
- F250** Words in reg. 36B(1) substituted (3.3.2009) by The Road Vehicles (Construction and Use) (Amendment) Regulations 2009 (S.I. 2009/142), regs. 1(2), **5(2)(i)**
- F251** Words in reg. 36B(1) inserted (3.3.2009) by The Road Vehicles (Construction and Use) (Amendment) Regulations 2009 (S.I. 2009/142), regs. 1(2), **5(2)(ii)**
- F252** Words in reg. 36B(1)(c) added (1.1.2005) by The Road Vehicles (Construction and Use) (Amendment) (No.2) Regulations 2004 (S.I. 2004/2102), regs. 1, **4(2)**
- F253** Reg. 36B(1A)-(1D) added (1.1.2005) by The Road Vehicles (Construction and Use) (Amendment) (No.2) Regulations 2004 (S.I. 2004/2102), regs. 1, **4(3)**
- F254** Words in reg. 36B(1A) substituted (3.3.2009) by The Road Vehicles (Construction and Use) (Amendment) Regulations 2009 (S.I. 2009/142), regs. 1(2), **5(3)**
- F255** Reg. 36B(1B) substituted (12.12.2005) by The Road Vehicles (Construction and Use)(Amendment) (No. 5) Regulations 2005 (S.I. 2005/3170), regs. 1, **4(2)**
- F256** Words in reg. 36B(1B) substituted (3.3.2009) by The Road Vehicles (Construction and Use) (Amendment) Regulations 2009 (S.I. 2009/142), regs. 1(2), **5(4)(a)**
- F257** Word in reg. 36B(1B) omitted (3.3.2009) by virtue of The Road Vehicles (Construction and Use) (Amendment) Regulations 2009 (S.I. 2009/142), regs. 1(2), **5(4)(b)**
- F258** Reg. 36B(1C)(1D) omitted (3.3.2009) by virtue of The Road Vehicles (Construction and Use) (Amendment) Regulations 2009 (S.I. 2009/142), regs. 1(2), **5(5)**
- F259** Words in reg. 36B(2) substituted (1.9.2003) by The Road Vehicles (Construction and Use) (Amendment) (No. 3) Regulations 2003 (S.I. 2003/1946), regs. 1, **5(2)**
- F260** Words in reg. 36B(2)(d) substituted (1.1.2005) by The Road Vehicles (Construction and Use) (Amendment) (No.2) Regulations 2004 (S.I. 2004/2102), regs. 1, **4(4)**

*Status: This revised version has been created from an electronic version contributed by Westlaw which was originally derived from the printed publication. **Read more** (See end of Document for details)**Changes to legislation: There are currently no known outstanding effects for the The Road Vehicles (Construction and Use) Regulations 1986. (See end of Document for details)***

- F261** Reg. 36B(3)-(5) omitted (1.9.1996) by virtue of The Road Vehicles (Construction and Use) (Amendment) (No. 3) Regulations 1996 (S.I. 1996/2064), regs. 1(2), **3(2)**
- F262** Words in reg. 36B(8) omitted (1.9.2003) by virtue of The Road Vehicles (Construction and Use) (Amendment) (No. 3) Regulations 2003 (S.I. 2003/1946), regs. 1, **5(3)**
- F263** Reg. 36B(9) substituted (1.9.1996) by The Road Vehicles (Construction and Use) (Amendment) (No. 3) Regulations 1996 (S.I. 1996/2064), regs. 1(2), **3(3)**
- F264** Words in reg. 36B(9) omitted (1.1.2005) by virtue of The Road Vehicles (Construction and Use) (Amendment) (No.2) Regulations 2004 (S.I. 2004/2102), regs. 1, **4(5)(a)**
- F265** Words in reg. 36B(9) added (1.1.2005) by The Road Vehicles (Construction and Use) (Amendment) (No.2) Regulations 2004 (S.I. 2004/2102), regs. 1, **4(5)(b)**
- F266** Words in reg. 36B(9) substituted (1.1.2005) by The Road Vehicles (Construction and Use) (Amendment) (No.2) Regulations 2004 (S.I. 2004/2102), regs. 1, **4(5)(c)**
- F267** Words in reg. 36B(10) omitted (1.9.2003) by virtue of The Road Vehicles (Construction and Use) (Amendment) (No. 3) Regulations 2003 (S.I. 2003/1946), regs. 1, **5(4)**
- F268** Words in reg. 36B(10)(b) added (1.1.2005) by The Road Vehicles (Construction and Use) (Amendment) (No.2) Regulations 2004 (S.I. 2004/2102), regs. 1, **4(6)**
- F269** Words in reg. 36B(11) added (1.1.2005) by The Road Vehicles (Construction and Use) (Amendment) (No.2) Regulations 2004 (S.I. 2004/2102), regs. 1, **4(7)(a)**
- F270** Words in reg. 36B(11) added (1.1.2005) by The Road Vehicles (Construction and Use) (Amendment) (No.2) Regulations 2004 (S.I. 2004/2102), regs. 1, **4(7)(b)**
- F271** Reg. 36B(11A) omitted (1.1.2005) by virtue of The Road Vehicles (Construction and Use) (Amendment) (No.2) Regulations 2004 (S.I. 2004/2102), regs. 1, **4(8)**
- F272** Reg. 36B(12A) omitted (1.1.2005) by virtue of The Road Vehicles (Construction and Use) (Amendment) (No.2) Regulations 2004 (S.I. 2004/2102), regs. 1, **4(9)**
- F273** Words in reg. 36B(14)(e) substituted (S.) (2.8.2005) by The Fire (Scotland) Act 2005 (Consequential Modifications and Amendments) (No. 2) Order 2005 (S.S.I. 2005/344), art. 1, **sch. para. 5(4)(a); S.S.I. 2005/392, art. 2**
- F274** Words in reg. 36B(14)(e) inserted (W.) (25.10.2005) by The Fire and Rescue Services Act 2004 (Consequential Amendments) (Wales) Order 2005 (S.I. 2005/2929), arts. 1(1), **11(4)(a)**
- F275** Words in reg. 36B(14)(e) inserted (E.) (30.12.2004) by The Fire and Rescue Services Act 2004 (Consequential Amendments) (England) Order 2004 (S.I. 2004/3168), arts. 1(1), **10(4)(a)**
- F276** Word in reg. 36B(14) omitted (3.3.2009) by virtue of The Road Vehicles (Construction and Use) (Amendment) Regulations 2009 (S.I. 2009/142), regs. 1(2), **5(6)(a)**
- F277** Reg. 36B(14)(f) substituted (1.7.1995) by Road Vehicles (Construction and Use) (Amendment) (No. 4) Regulations 1995 (S.I. 1995/1458), regs. 1, **2**
- F278** Reg. 36B(14)(g) and word inserted (3.3.2009) by The Road Vehicles (Construction and Use) (Amendment) Regulations 2009 (S.I. 2009/142), regs. 1(2), **5(6)(b)**
- F279** Words in reg. 36B(15) omitted (1.9.1996) by virtue of The Road Vehicles (Construction and Use) (Amendment) (No. 3) Regulations 1996 (S.I. 1996/2064), regs. 1(2), **3(6)(a)**
- F280** Words in reg. 36B(15) added (12.12.2005) by The Road Vehicles (Construction and Use)(Amendment) (No. 5) Regulations 2005 (S.I. 2005/3170), regs. 1, **4(3)**
- F281** Words in reg. 36B(15) added (1.1.2005) by The Road Vehicles (Construction and Use) (Amendment) (No.2) Regulations 2004 (S.I. 2004/2102), regs. 1, **4(11)**
- F282** Word in reg. 36B(15) omitted (1.9.1996) by virtue of The Road Vehicles (Construction and Use) (Amendment) (No. 3) Regulations 1996 (S.I. 1996/2064), regs. 1(2), **3(6)(b)**
- F283** Words in reg. 36B(15) inserted (1.9.1996) by The Road Vehicles (Construction and Use) (Amendment) (No. 3) Regulations 1996 (S.I. 1996/2064), regs. 1(2), **3(6)(b)**
- F284** Words in reg. 36B(15) omitted (1.1.2005) by virtue of The Road Vehicles (Construction and Use) (Amendment) (No.2) Regulations 2004 (S.I. 2004/2102), regs. 1, **4(10)(a)**
- F285** Words in reg. 36B(15) inserted (1.1.2005) by The Road Vehicles (Construction and Use) (Amendment) (No.2) Regulations 2004 (S.I. 2004/2102), regs. 1, **4(10)(b)**

**Status:** Point in time view as at 31/03/2009.

**Status:** This revised version has been created from an electronic version contributed by Westlaw which was originally derived from the printed publication. **Read more** (See end of Document for details)**Changes to legislation:** There are currently no known outstanding effects for the The Road Vehicles (Construction and Use) Regulations 1986. (See end of Document for details)

**F286** Words in reg. 36B(16) substituted (24.3.1994) by The Road Vehicles (Construction and Use) (Amendment) (No. 2) Regulations 1994 (S.I. 1994/329), regs. 1, 5

### **[<sup>F287</sup>Speed limiters — authorised sealers**

**36C.** Schedule 3B (authorised sealers) shall have effect.]

#### **Textual Amendments**

**F287** Reg. 36C inserted (1.8.1992) by The Road Vehicles (Construction and Use) (Amendment) (No. 2) Regulations 1992 (S.I. 1992/422), regs. 1(2), 5(1)

### **Audible warning instruments**

- (a) **37.** (1) (a) Subject to sub-paragraph (b), every motor vehicle which has a maximum speed of more than 20 mph shall be fitted with a horn, not being a reversing alarm or a two-tone horn.
- (b) Sub-paragraph (a) shall not apply to an agricultural motor vehicle, unless it is being driven at more than 20 mph.
- (2) Subject to paragraph (6), the sound emitted by any horn, other than a reversing alarm or a two-tone horn, fitted to a wheeled vehicle first used on or after 1st August 1973 shall be continuous and uniform and not strident.
- (3) A reversing alarm fitted to a wheeled vehicle shall not be strident.
- (4) Subject to paragraphs (5), (6) and (7) no motor vehicle shall be fitted with a bell, gong, siren or two-tone horn.
- (5) The provisions of paragraph (4) shall not apply to motor vehicles—
- (a) used for [<sup>F288</sup>fire brigade][<sup>F288</sup>relevant authority (as defined in section 6 of the Fire (Scotland) Act 2005 (asp 5))][<sup>F289</sup>or, in England or Wales, fire and rescue authority][<sup>F290</sup>or, in England, fire and rescue authority], ambulance or police purposes;
- [<sup>F291</sup>(aa) as regards England and Wales, and so far as relating to the functions of the Serious Organised Crime Agency which are exercisable in or as regards Scotland and which relate to reserved matters (within the meaning of the Scotland Act 1998), used for Serious Organised Crime Agency purposes;]
- [<sup>F292</sup>(ab) so far as relating to the functions of the Serious Organised Crime Agency which are exercisable in or as regards Scotland and which do not (within the meaning of the Scotland Act 1998) relate to reserved matters, used for Serious Organised Crime Agency purposes;]
- (b) owned by a body formed primarily for the purposes of fire salvage and used for those or similar purposes;
- (c) owned by the Forestry Commission or by local authorities and used from time to time for the purposes of fighting fires;
- (d) owned by the Secretary of State for Defence and used for the purposes of the disposal of bombs or explosives;
- (e) used for the purposes of the Blood Transfusion Service provided under the National Health Service Act 1977 or under the National Health Service (Scotland) Act 1947;
- (f) used by Her Majesty's Coastguard or the Coastguard Auxiliary Service to aid persons in danger or vessels in distress on or near the coast;

- [<sup>F293</sup>(g) used for the purposes of rescue operations at mines;]
- (h) owned by the Secretary of State for Defence and used by the Royal Air Force Mountain Rescue Service for the purposes of rescue operations in connection with crashed aircraft or any other emergencies; <sup>F294</sup> ...
- (i) owned by the Royal National Lifeboat Institution and used for the purposes of launching lifeboats;
- [<sup>F295</sup>(j) a vehicle under the lawful control of the Commissioners for Her Majesty's Revenue and Customs and used from time to time for the purposes of investigation of serious crime (which, save for the omission of the words "and, where the authorising officer is within subsection (5)(h), it relates to an assigned matter within the meaning of section 1(1) of the Customs and Excise Management Act 1979", has the meaning given by section 93(4) of the Police Act 1997); or
- (k) owned or operated by the Secretary of State for Defence and used for the purpose of any activity—
  - (i) which prevents or decreases the exposure of persons to radiation arising from a radiation accident or radiation emergency; or
  - (ii) in connection with an event which could lead to a radiation accident or radiation emergency.]

(6) The provisions of paragraphs (2) and (4) shall not apply so as to make it unlawful for a motor vehicle to be fitted with an instrument or apparatus (not being a two-tone horn) designed to emit a sound for the purpose of informing members of the public that goods are on the vehicle for sale.

(7) Subject to paragraph (8), the provisions of paragraph (4) shall not apply so as to make it unlawful for a vehicle to be fitted with a bell, gong or siren—

- (a) if the purpose thereof is to prevent theft or attempted theft of the vehicle or its contents; or
- (b) in the case of a bus, if the purpose thereof is to summon help for the driver, the conductor or an inspector.

(8) Every bell, gong or siren fitted to a vehicle by virtue of paragraph (7)(a), and every device fitted to a motor vehicle first used on or after 1st October 1982 so as to cause a horn to sound for the purpose mentioned in paragraph (7)(a), shall be fitted with a device designed to stop the bell, gong, siren or horn emitting noise for a continuous period of more than five minutes; and every such device shall at all times be maintained in good working order.

(9) Instead of complying with paragraphs (1), (2) and (4) to (8), a vehicle may comply with Community Directive 70/388 or ECE Regulation 28 or, if the vehicle is an agricultural motor vehicle, with Community Directive 74/151.

[<sup>F296</sup>(9A) In this regulation "radiation accident" and "radiation emergency" shall have the same meaning as in the Radiation (Emergency Preparedness and Public Information) Regulations 2001.]

(10) In this regulation and in regulation 99—

- (a) "horn" means an instrument, not being a bell, gong or siren, capable of giving audible and sufficient warning of the approach or position of the vehicle to which it is fitted;
- (b) references to a bell, gong or siren include references to any instrument or apparatus capable of emitting a sound similar to that emitted by a bell, gong or siren;
- (c) "reversing alarm" means a device fitted to a motor vehicle and designed to warn persons that the vehicle is reversing or is about to reverse; and
- (d) "two-tone horn" means an instrument which, when operated, automatically produces a sound which alternates at regular intervals between two fixed notes.

**Status:** Point in time view as at 31/03/2009.

**Status:** This revised version has been created from an electronic version contributed by Westlaw which was originally derived from the printed publication. **Read more** (See end of Document for details)**Changes to legislation:** There are currently no known outstanding effects for the The Road Vehicles (Construction and Use) Regulations 1986. (See end of Document for details)

### Textual Amendments

- F288** Words in reg. 37(5)(a) substituted (S.) (2.8.2005) by The Fire (Scotland) Act 2005 (Consequential Modifications and Amendments) (No. 2) Order 2005 (S.S.I. 2005/344), art. 1, **sch. 1 para. 5(4)(b)**; S.S.I. 2005/392, art. 2
- F289** Words in reg. 37(5)(a) inserted (W.) (25.10.2005) by The Fire and Rescue Services Act 2004 (Consequential Amendments) (Wales) Order 2005 (S.I. 2005/2929), arts. 1(1), **11(4)(b)**
- F290** Words in reg. 37(5)(a) inserted (E.) (30.12.2004) by The Fire and Rescue Services Act 2004 (Consequential Amendments) (England) Order 2004 (S.I. 2004/3168), arts. 1(1), **10(4)(b)**
- F291** Reg. 37(5)(aa) inserted (1.4.2006) by The Serious Organised Crime and Police Act 2005 (Consequential and Supplementary Amendments to Secondary Legislation) Order 2006 (S.I. 2006/594), art. 1, **Sch. para. 8**
- F292** Reg. 37(5)(ab) inserted (S.) (1.4.2006) by The Serious Organised Crime and Police Act 2005 (Consequential and Supplementary Amendments) (Scotland) Order 2006 (S.S.I. 2006/129), art. 1, **sch. para. 1**
- F293** Reg. 37(5)(g) substituted (31.10.1994) by The Coal Industry Act 1994 (Consequential Modifications of Subordinate Legislation) Order 1994 (S.I. 1994/2567), reg. 1, **Sch.**
- F294** Word in reg. 37(5) omitted (21.10.2005) by virtue of The Road Vehicles (Construction and Use) (Amendment) (No.2) Regulations 2005 (S.I. 2005/2560), regs. 1, **2(2)(a)**
- F295** Reg. 37(5)(j)(k) added (21.10.2005) by The Road Vehicles (Construction and Use) (Amendment) (No.2) Regulations 2005 (S.I. 2005/2560), regs. 1, **2(2)(b)**
- F296** Reg. 37(9A) added (21.10.2005) by The Road Vehicles (Construction and Use) (Amendment) (No.2) Regulations 2005 (S.I. 2005/2560), regs. 1, **2(3)**

### Commencement Information

- I33** Reg. 37 in force at 11.8.1986, see **reg. 1**

### Motor cycle sidestands

**38.**—(1) No motor cycle first used on or after 1st April 1986 shall be fitted with any sidestand which is capable of—

- (a) disturbing the stability or direction of the motor cycle when it is in motion under its own power; or
- (b) closing automatically if the angle of the inclination of the motor cycle is inadvertently altered when it is stationary.

(2) In this regulation “sidestand” means a device fitted to a motor cycle which, when fully extended or pivoted to its open position, supports the vehicle from one side only and so that both the wheels of the motor cycle are on the ground.

### Commencement Information

- I34** Reg. 38 in force at 11.8.1986, see **reg. 1**

## G

### FUEL

#### [<sup>F297</sup>Fuel tanks]

**39.**—[<sup>F298</sup>(1) This regulation applies to every fuel tank which is fitted to a wheeled vehicle for the purpose of supplying fuel to the propulsion unit or to an ancillary engine or to any other equipment forming part of the vehicle.

- (2) Subject to paragraphs (3) [<sup>F299</sup>, (3A)] and (4), every fuel tank to which this regulation applies—
- (a) shall be constructed and maintained so that the leakage of any liquid from the tank is adequately prevented;
  - (b) shall be constructed and maintained so that the leakage of vapour from the tank is adequately prevented; and
  - (c) if it contains petroleum spirit (as defined in section 23 of the Petroleum (Consolidation) Act 1928) and is fitted to a vehicle first used on or after 1st July 1973, shall be—
    - (i) made only of metal; and
    - (ii) fixed in such a position and so maintained as to be reasonably secure from damage.

(3) Notwithstanding the requirement of paragraph (2)(b), the fuel tank may be fitted with a device which, by the intake of air or the emission of vapour, relieves changes of pressure in the tank.]

[<sup>F300</sup>(3A) Sub-paragraph (i) of paragraph 2(c) shall not have effect in relation to a two-wheeled motor cycle (with or without a side-car) first used on or after 1st February 1993.]

[<sup>F301</sup>(4)] Instead of complying with the requirements of [<sup>F302</sup>paragraphs (2) and (3)] as to construction, a vehicle may comply with the requirements of Community Directive 70/221 (insofar as they relate to fuel tanks) or ECE Regulation 34 or 34.01 or, if the vehicle is an agricultural motor vehicle, of Community Directive 74/151.

#### Textual Amendments

- F297** Reg. 39 crossheading substituted (10.12.1990) by [The Road Vehicles \(Construction and Use\) \(Amendment\) \(No. 5\) Regulations 1990](#) (S.I. 1990/2212), regs. 1, **3** (with reg. 2(2))
- F298** Reg. 39(1)-(3) substituted for reg. 39(1) (10.12.1990) by [The Road Vehicles \(Construction and Use\) \(Amendment\) \(No. 5\) Regulations 1990](#) (S.I. 1990/2212), regs. 1, **4** (with reg. 2(2))
- F299** Word in reg. 39(2) inserted (1.2.1993) by [The Road Vehicles \(Construction and Use\) \(Amendment\) \(No. 8\) Regulations 1992](#) (S.I. 1992/3285), regs. 1, **3(a)**
- F300** Reg. 39(3A) inserted (1.2.1993) by [The Road Vehicles \(Construction and Use\) \(Amendment\) \(No. 8\) Regulations 1992](#) (S.I. 1992/3285), regs. 1, **3(b)**
- F301** Reg. 39(2) renumbered as reg. 39(4) (10.12.1990) by [The Road Vehicles \(Construction and Use\) \(Amendment\) \(No. 5\) Regulations 1990](#) (S.I. 1990/2212), regs. 1, **5** (with reg. 2(2))
- F302** Words in reg. 39(4) substituted (10.12.1990) by [The Road Vehicles \(Construction and Use\) \(Amendment\) \(No. 5\) Regulations 1990](#) (S.I. 1990/2212), regs. 1, **5** (with reg. 2(2))

#### Commencement Information

- I35** Reg. 39 in force at 11.8.1986, see [reg. 1](#)

[<sup>F303</sup>**39A.**—(1) Every vehicle to which this regulation applies shall be designed and constructed for running on unleaded petrol.

**Status:** Point in time view as at 31/03/2009.

**Status:** This revised version has been created from an electronic version contributed by Westlaw which was originally derived from the printed publication. **Read more** (See end of Document for details)**Changes to legislation:** There are currently no known outstanding effects for the The Road Vehicles (Construction and Use) Regulations 1986. (See end of Document for details)

(2) No person shall use or cause or permit to be used a vehicle to which this regulation applies on a road if it —

- (a) has been deliberately altered or adjusted for running on leaded petrol, and
- (b) as a direct result of such alteration or adjustment it is incapable of running on unleaded petrol.

(3) Subject to paragraph (4) this regulation applies to every motor vehicle which is —

- (a) propelled by a spark ignition engine which is capable of running on petrol, and
- (b) is first used on or after the 1st April 1991.

(4) Part I of Schedule 3A shall have effect for the purpose of excluding certain vehicles first used before specified dates from the application of this regulation.

(5) In this regulation “petrol”, “leaded petrol” and “unleaded petrol” have the same meaning as in Community Directive 85/210.

(6) A vehicle shall be regarded for the purposes of this regulation as incapable of running on unleaded petrol at any particular time if and only if in its state of adjustment at that time prolonged continuous running on such petrol would damage the engine.

#### Textual Amendments

**F303** Regs. 39A, 39B inserted (1.10.1988) by [The Road Vehicles \(Construction and Use\) \(Amendment\) \(No. 6\) Regulations 1988 \(S.I. 1988/1524\)](#), regs. 1, 5

**39B.**—(1) Subject to paragraph (2), every fuel tank fitted to a vehicle to which regulation 39A applies shall be so constructed and fitted that it cannot readily be filled from a petrol pump delivery nozzle which has an external diameter of 23.6mm or greater without the aid of a device (such as a funnel) not fitted to the vehicle.

(2) Paragraph (1) does not apply to a vehicle in respect of which both of the following conditions are satisfied, that is to say —

- (a) that at the time of its first use the vehicle is so designed and constructed that prolonged continuous running on leaded petrol would not cause any device designed to control the emission of carbon monoxide, hydrocarbons or nitrogen oxides to malfunction, and
- (b) that it is conspicuously and legibly marked in a position immediately visible to a person filling the fuel tank with —
  - (i) the word “UNLEADED”, or
  - (ii) the symbol shown in Part II of Schedule 3A.

(3) In this regulation “fuel tank”, in relation to a vehicle, means a fuel tank used in connection with the propulsion of the vehicle.]

#### Textual Amendments

**F303** Regs. 39A, 39B inserted (1.10.1988) by [The Road Vehicles \(Construction and Use\) \(Amendment\) \(No. 6\) Regulations 1988 \(S.I. 1988/1524\)](#), regs. 1, 5

### Gas propulsion systems and gas-fired appliances

**40.**—(1) A vehicle which is—



**Status:** This revised version has been created from an electronic version contributed by Westlaw which was originally derived from the printed publication. **Read more** (See end of Document for details)**Changes to legislation:** There are currently no known outstanding effects for the The Road Vehicles (Construction and Use) Regulations 1986. (See end of Document for details)

(a) a motor vehicle which first used gas as a fuel for its propulsion before 19th November 1982; or  
(b) a trailer manufactured before 19th November 1982 to which there is fitted a gas container,  
shall be so constructed that it complies either with the provisions of Schedule 4 or with the provisions of Schedule 5.

(2) [<sup>F304</sup>Subject to paragraph (2A), a vehicle which is]—

- (a) a motor vehicle which first used gas as a fuel for its propulsion on or after 19th November 1982; or  
(b) a motor vehicle first used on or after 1st May 1984 or a trailer manufactured on or after 19th November 1982 which is in either case equipped with a gas container or a gas-fired appliance,

shall comply with the provisions of Schedule 5 [<sup>F305</sup>or with ECE Regulation 67 or 67.01].

[<sup>F306</sup>(2A) A vehicle which first used gas as a fuel for its propulsion on or after 13th November 1999 shall comply with the provisions of Schedule 5 or ECE Regulation 67.01].

(3) The requirements of this regulation are in addition to, and not in derogation from, the requirements of any regulations made under powers conferred by the petroleum (Consolidation) Act 1928, the Health and Safety at Work etc. Act 1974, the Control of Pollution Act 1974 or any other Act or of any codes of practice issued under the Health and Safety at Work etc. Act 1974.

(4) In this regulation “gas container” has the meaning given in Schedule 4 where compliance with the provisions of that Schedule is concerned and otherwise has the meaning given in Schedule 5.

#### Textual Amendments

- F304** Words in [reg. 40\(2\)](#) substituted (1.8.2003) by [The Road Vehicles \(Construction and Use\) \(Amendment\) \(No. 2\) Regulations 2003 \(S.I. 2003/1690\)](#), regs. 1, **3(2)(a)**  
**F305** Words in [reg. 40\(2\)](#) inserted (1.8.2003) by [The Road Vehicles \(Construction and Use\) \(Amendment\) \(No. 2\) Regulations 2003 \(S.I. 2003/1690\)](#), regs. 1, **3(2)(b)**  
**F306** [Reg. 40\(2A\)](#) inserted (1.8.2003) by [The Road Vehicles \(Construction and Use\) \(Amendment\) \(No. 2\) Regulations 2003 \(S.I. 2003/1690\)](#), regs. 1, **3(3)**

#### Commencement Information

- I36** [Reg. 40](#) in force at 11.8.1986, see [reg. 1](#)

## H

### MINIBUSES

#### Minibuses

**41.** The requirements specified in Schedule 6 shall apply to every minibus first used on or after 1st April 1988 except a vehicle—

- (a) manufactured by Land Rover U.K. Limited and known as the Land Rover; or  
(b) constructed or adapted for the secure transport of prisoners.

#### Commencement Information

- I37** [Reg. 41](#) in force at 11.8.1986, see [reg. 1](#)

**Status:** Point in time view as at 31/03/2009.

**Status:** This revised version has been created from an electronic version contributed by Westlaw which was originally derived from the printed publication. **Read more** (See end of Document for details)**Changes to legislation:** There are currently no known outstanding effects for the The Road Vehicles (Construction and Use) Regulations 1986. (See end of Document for details)

## [<sup>F307</sup> Alternative means of compliance

### 41A.—[

<sup>F308</sup>(1)] A minibus which is required by regulation 41 to meet the requirements specified in Schedule 6 need not meet them if it meets the requirements of such of the Annexes to Directive 2001/85/EC of the European Parliament and of the Council of 20 November 2001, relating to special provisions for vehicles used for the carriage of passengers comprising more than eight seats in addition to the driver's seat, and amending Directives 70/156/EEC and 97/27/EC, as apply to that minibus.

[

<sup>F309</sup>(2) A minibus which is required by regulation 41 to meet the requirements specified in Schedule 6 need not meet the requirements set out in items 2 to 4 and 7 to 12 of that Schedule if it meets such requirements of ECE Regulation 52.01 or 107.01 or 107.02 as apply to that minibus.]]

#### Textual Amendments

**F307** Reg. 41A added (12.12.2005) by The Road Vehicles (Construction and Use) (Amendment) (No.3) Regulations 2005 (S.I. 2005/2987), regs. 1, 3

**F308** Reg. 41A renumbered as reg. 41A(1) (3.3.2009) by The Road Vehicles (Construction and Use) (Amendment) Regulations 2009 (S.I. 2009/142), regs. 1(2), 6(2)(a)

**F309** Reg. 41A(2) added (3.3.2009) by The Road Vehicles (Construction and Use) (Amendment) Regulations 2009 (S.I. 2009/142), regs. 1(2), 6(2)(b)

## Fire extinguishing apparatus

42.—(1) No person shall use, or cause or permit to be used, on a road a minibus first used on or after 1st April 1988 unless it carries suitable and efficient apparatus for extinguishing fire which is of a type specified in Part I of Schedule 7.

(2) The apparatus referred to in paragraph (1) above shall be—

- (a) readily available for use;
- (b) clearly marked with the appropriate British Standards Institution specification number; and
- (c) maintained in good and efficient working order.

(3) This regulation does not apply to a vehicle manufactured by Land Rover U.K. Limited and known as the Land Rover.

#### Commencement Information

**I38** Reg. 42 in force at 11.8.1986, see [reg. 1](#)

## First aid equipment

43.—(1) No person shall use, or cause or permit to be used, on a road a minibus first used on or after 1st April 1988 unless it carries a receptacle which contains the items specified in Part II of Schedule 7.

(2) The receptacle referred to in paragraph (1) above shall be—

- (a) maintained in a good condition;
- (b) suitable for the purpose of keeping the items referred to in the said paragraph in good condition;

Status: This revised version has been created from an electronic version contributed by Westlaw which was originally derived from the printed publication. Read more (See end of Document for details) Changes to legislation: There are currently no known outstanding effects for the The Road Vehicles (Construction and Use) Regulations 1986. (See end of Document for details)

- (c) readily available for use; and
- (d) prominently marked as a first aid receptacle.

(3) The items referred to in paragraph (1) above shall be maintained in good condition and shall be of a good and reliable quality and of a suitable design.

(4) This regulation does not apply to a vehicle manufactured by Land Rover U.K. Limited and known as the Land Rover.

**Commencement Information**

I39 Reg. 43 in force at 11.8.1986, see reg. 1

**Carriage of dangerous substances**

44.—(1) Save as provided in paragraph (2), no person shall use or cause or permit to be used on a road a minibus by which any highly inflammable or otherwise dangerous substance is carried unless that substance is carried in containers so designed and constructed, and unless the substance is so packed, that, notwithstanding an accident to the vehicle, it is unlikely that damage to the vehicle or injury to passengers in the vehicle will be caused by the substance.

(2) Paragraph (1) shall not apply in relation to the electrolyte of a battery installed in an electric wheelchair provided that the wheelchair is securely fixed to the vehicle.

(3) This regulation does not apply to a vehicle manufactured by Land Rover U.K. Limited and known as the Land Rover.

**Commencement Information**

I40 Reg. 44 in force at 11.8.1986, see reg. 1

I

POWER TO WEIGHT RATIO

**Power to weight ratio**

<sup>F310</sup>45. ....

**Textual Amendments**

F310 Reg. 45 omitted (1.6.1995) by virtue of The Road Vehicles (Construction and Use) (Amendment) (No. 3) Regulations 1995 (S.I. 1995/1201), regs. 1, 4

J

PROTECTIVE SYSTEMS

**Seat belt anchorage points**

[<sup>F311</sup>46.—(1) This regulation applies to a motor vehicle which is not an excepted vehicle and is—

- (a) a bus first used on or after 1st April 1982;
- (b) a wheeled motor car first used on or after 1st January 1965;

**Status:** Point in time view as at 31/03/2009.

**Status:** This revised version has been created from an electronic version contributed by Westlaw which was originally derived from the printed publication. **Read more** (See end of Document for details) **Changes to legislation:** There are currently no known outstanding effects for the The Road Vehicles (Construction and Use) Regulations 1986. (See end of Document for details)

- (c) a three-wheeled motor cycle which has an unladen weight exceeding 255 kg and which was first used on or after 1st September 1970; or
- (d) a heavy motor car first used on or after 1st October 1988.
- (2) Each of the following is an excepted vehicle—
- (a) a goods vehicle (other than a dual-purpose vehicle)—
- (i) first used before 1st April 1967;
- (ii) first used on or after 1st April 1980 and before 1st October 1988 and having a maximum gross weight exceeding 3500 kg; or
- (iii) first used before 1st April 1980 or, if the vehicle is of a model manufactured before 1st October 1979, first used before 1st April 1982 and, in either case, having an unladen weight exceeding 1525 kg;
- (b) an agricultural motor vehicle;
- (c) a motor tractor;
- (d) a works truck;
- (e) an electrically propelled goods vehicle first used before 1st October 1988;
- (f) a pedestrian-controlled vehicle;
- (g) a vehicle which has been used on roads outside Great Britain, whilst it is being driven from the place at which it arrived in Great Britain to a place of residence of the owner or driver of the vehicle, or from any such place to a place where, by previous arrangement, it will be provided with such anchorage points as are required by this regulation and with such seat belts as are required by regulation 47;
- (h) a vehicle having a maximum speed not exceeding 16 mph;
- (i) a motor cycle equipped with a driver's seat of a type requiring the driver to sit astride it, and which is constructed or assembled by a person not ordinarily engaged in the trade or business of manufacturing vehicles of that description;
- (j) a locomotive.

(3) A vehicle which falls within a description specified in column (2) of an item in the Table below shall be equipped with anchorage points for seat belts for the use of persons sitting in the seats specified in column (3) of that item and those anchorage points (“mandatory anchorage points”) shall comply with the requirements specified in column (4).

**TABLE**

<i>(1)</i> <i>Item</i>	<i>(2)</i> <i>Description of vehicle</i>	<i>(3)</i> <i>Seats for which mandatory anchorage points are to be provided</i>	<i>(4)</i> <i>Technical and installation requirements</i>
1.	Any vehicle first used before 1st April 1982	The driver's seat and specified passenger seat (if any)	Anchorage points must be designed to hold seat belts securely in position on the vehicle
2.	Minibus constructed or adapted to carry not more than 12 seated passengers in addition to the driver, motor	The driver's seat and specified passenger seat (if any)	The technical and installation (but not the testing) requirements of Community Directive 76/115,

*Status: This revised version has been created from an electronic version contributed by Westlaw which was originally derived from the printed publication. Read more (See end of Document for details) Changes to legislation: There are currently no known outstanding effects for the The Road Vehicles (Construction and Use) Regulations 1986. (See end of Document for details)*

<i>(1) Item</i>	<i>(2) Description of vehicle</i>	<i>(3) Seats for which mandatory anchorage points are to be provided</i>	<i>(4) Technical and installation requirements</i>
	ambulance or motor caravan which, in any such case, was first used on or after 1st April 1982 but before 1st October 1988		81/575, 82/318, 90/629 or 96/38 or ECE Regulation 14, 14.01, 14.02, 14.03, 14.04 or 14.05 whether or not those instruments apply to the vehicle
3.	Minibus (not being a vehicle falling within item 7 or 8) having a gross weight not exceeding 3500 kg, motor ambulance or motor caravan which, in any such case, was first used on or after 1st October 1988	The driver's seat and each forward-facing front seat	The requirements specified in column (4) of item 2
4.	Goods vehicle first used on or after 1st October 1988 but before 1st October 2001 and having a maximum gross weight exceeding 3500 kg	The driver's seat and each forward-facing front seat	2 or 3 anchorage points designed to hold seat belts securely in position
5.	Goods vehicle first used on or after 1st October 2001 and having a maximum gross weight exceeding 3500 kg	All forward-facing front seats	The technical and installation requirements of Community Directive 96/38 or ECE Regulation 14.04 or 14.05
6.	Coach first used on or after 1st October 1988 but before 1st October 2001	All exposed forward-facing seats	The requirements specified in column (4) of item 2 or, if the anchorage points were fitted before 1st October 2001 and form part of a seat, a requirement that they do not, when a forward horizontal force is applied to them, become detached from the seat before the seat

**Status:** Point in time view as at 31/03/2009.

**Status:** This revised version has been created from an electronic version contributed by Westlaw which was originally derived from the printed publication. **Read more** (See end of Document for details)**Changes to legislation:** There are currently no known outstanding effects for the The Road Vehicles (Construction and Use) Regulations 1986. (See end of Document for details)

(1) Item	(2) Description of vehicle	(3) Seats for which mandatory anchorage points are to be provided	(4) Technical and installation requirements
			becomes detached from the vehicle
7.	Bus (other than an urban bus) having a gross vehicle weight exceeding 3500 kg and first used on or after 1st October 2001	Anchorage points for every forward-facing and every rearward-facing seat	The requirements specified in column (4) of item 5
8.	Bus (other than an urban bus) having a gross vehicle weight not exceeding 3500 kg and first used on or after 1st October 2001	Every forward-facing and every rearward-facing seat	The requirements specified in column (4) of item 5
9.	Passenger or dual-purpose vehicle (other than a bus) first used on or after 1st April 1982 and not falling within any of items 2 to 8	Every forward-facing seat constructed or adapted to accommodate no more than one adult	The requirements specified in column (4) of item 2
10.	Vehicle (other than a bus) first used on or after 1st April 1982 and not falling within any of items 2 to 9	Every forward-facing front seat and every non-protected seat	The requirements specified in column (4) of item 2

(4) Any anchorage fitted after 1st October 2001 to a bus not falling within item 7 or 8 of the Table in paragraph (3) must comply with the technical and installation (but not the testing) requirements of Community Directive 76/115, 81/575, 82/318, 90/629 or 96/38 or ECE Regulation 14, 14.01, 14.02, 14.03, 14.04 or 14.05 whether or not those instruments apply to the vehicle.

(5) Subject to paragraph (6), where a vehicle to which this regulation applies and which falls within a class specified in an item of the Table in paragraph (3) is fitted with non-mandatory anchorage points, those anchorage points shall comply with the requirements applicable to the mandatory anchorage points specified for that item.

(6) Paragraph (5) does not apply to non-mandatory anchorage points fitted to—

- (a) a minibus before 1st April 1986; or
- (b) any other vehicle before 1st October 1988.

(7) For the purposes of this regulation—

- (a) the expressions “exposed forward-facing seat”, “forward-facing front seat”, “lap belt”, “seat belt” and “specified passenger’s seat” have the same meaning as in regulation 47(8);

**Status:** This revised version has been created from an electronic version contributed by Westlaw which was originally derived from the printed publication. **Read more** (See end of Document for details) **Changes to legislation:** There are currently no known outstanding effects for the The Road Vehicles (Construction and Use) Regulations 1986. (See end of Document for details)

- (b) “mandatory anchorage points” has the meaning given in paragraph (3) and “non-mandatory anchorage points” means anchorage points which are not mandatory anchorage points;
- (c) a seat is a “non-protected seat” if it is not a front seat and the screen zones within the protected area have a combined surface of less than 800 cm<sup>2</sup>;
- (d) “screen zone” and “protected area” in relation to a seat shall be construed in accordance with paragraph 4.3.3 of Annex I to Community Directive 81/575; and
- (e) “urban bus” means a bus designed for urban use with standing passengers and includes a vehicle which is—
  - (i) a Class I vehicle as defined by paragraph 2.1.2.1.3.1.1 of Annex I of Community Directive 97/27/EC;
  - (ii) a Class II vehicle as defined by paragraph 2.1.2.1.3.1.2 of that Annex; or
  - (iii) a Class A vehicle as defined by paragraph 2.1.2.1.3.2.1 of that Annex.

(8) A vehicle which is not required by this regulation to comply with the technical and installation requirements of Community Directive 76/115, 81/575, 82/318, 90/629 or 96/38 or ECE Regulation 14, 14.01, 14.02, 14.03, 14.04 or 14.05 shall nevertheless be taken to comply with the provisions of this regulation if it does comply with those requirements.]

#### Textual Amendments

**F311** Reg. 46 substituted (1.10.2001) by [The Road Vehicles \(Construction and Use\) \(Amendment\) \(No. 2\) Regulations 2001 \(S.I. 2001/1043\)](#), reg. 1, [Sch.](#)

#### Seat belts

- 47.**—(1) This regulation applies to every vehicle to which regulation 46 applies.
- (2) Save as provided in paragraph (4) a vehicle to which—
- (a) this regulation applies which was first used before 1st April 1981 shall be provided with—
    - (i) a body-restraining <sup>F312</sup>... belt, designed for use by an adult, for the driver's seat; and
    - (ii) a body-restraining <sup>F312</sup>... belt for the specified passenger's seat (if any);
  - (b) this regulation applies which is first used on or after 1st April 1981 shall be provided with three-point <sup>F313</sup>... belts for the driver's seat and for the specified passenger's seat (if any);
  - (c) [<sup>F314</sup>item 9 or 10 of the Table in regulation 46(3)] applies which is first used on or after 1st April 1987 shall be fitted with seat belts additional to those required by sub-paragraph (b) as follows—
    - (i) for any forward-facing front seat alongside the driver's seat, not being a specified passenger's seat, a seat belt which is a three-point belt, or a lap belt installed in accordance with paragraph 3.1.2.1 of Annex 1 to Community Directive 77/541 or a disabled person's belt;
    - (ii) in the case of a passenger or dual-purpose vehicle having not more than two forward-facing seats behind the driver's seat with either—
      - (A) an inertia reel belt for at least one of those seats, or
      - (B) a three-point belt, a lap belt, a disabled person's belt or a child restraint for each of those seats;

**Status:** Point in time view as at 31/03/2009.

**Status:** This revised version has been created from an electronic version contributed by Westlaw which was originally derived from the printed publication. **Read more** (See end of Document for details)**Changes to legislation:** There are currently no known outstanding effects for the The Road Vehicles (Construction and Use) Regulations 1986. (See end of Document for details)

- (iii) in the case of a passenger or dual-purpose vehicle having more than two forward-facing seats behind the driver's seat, with either—
  - (A) an inertia reel belt for one of those seats being an outboard seat and a three-point belt, a lap belt, a disabled person's belt or a child restraint for at least one other of those seats;
  - (B) a three-point belt for one of those seats and either a child restraint or a disabled person's belt for at least one other of those seats; or
  - (C) a three-point belt, a lap belt, a disabled person's belt or a child restraint for each of those seats.
- <sup>F315</sup>(d) <sup>F316</sup>item 3 of the Table in regulation 46(3)] applies shall be fitted with seat belts as follows—
  - (i) for the driver's seat and the specified passenger's seat (if any) a three-point belt; and
  - (ii) for any forward-facing front seat which is not a specified passenger's seat, a three-point belt or a lap belt installed in accordance with the provisions of subparagraph (c)(i);
- (e) <sup>F317</sup>item 4 of the Table in regulation 46(3)] applies shall be equipped with seat belts which shall be three-point belts, lap belts or disabled person's belts<sup>F318</sup>;
- (f) item 5 of the Table in regulation 46(3) applies shall be fitted—
  - (i) as respects the driver's seat with a three-point belt or a lap belt; and
  - (ii) as respects every other forward-facing front seat with a three-point belt, a lap belt installed in accordance with paragraph 3.1.2.1 of Annex I to Community Directive 77/541 or a disabled person's belt;
- (g) item 7 of the Table in regulation 46(3) applies shall be fitted, as respects every forward-facing seat, with—
  - (i) an inertia reel belt;
  - (ii) a retractable lap belt installed in compliance with paragraph 3.1.10 of Annex I to Community Directive 96/36 or 2000/3;
  - (iii) a disabled person's belt; or
  - (iv) a child restraint;
- (h) item 7 of the Table in regulation 46(3) applies shall be fitted, as respects every rearward-facing seat, with—
  - (i) an inertia reel belt;
  - (ii) a retractable lap belt;
  - (iii) a disabled person's belt; or
  - (iv) a child restraint;
- (i) item 8 of the Table in regulation 46(3), as respects every forward-facing seat, with—
  - (i) an inertia reel belt;
  - (ii) a disabled person's belt; or
  - (iii) a child restraint;
- (j) item 8 of the Table in regulation 46(3), as respects every rearward-facing seat, with—
  - (i) an inertia reel belt;
  - (ii) a retractable lap belt;
  - (iii) a disabled person's belt; or



(iv) a child restraint.]

[<sup>F319</sup>Where a lap belt is fitted to a forward-facing front seat of a minibus, a motor ambulance or a motor caravan, or to an exposed forward-facing seat [<sup>F320</sup>(other than the driver's seat or any crew seat) of a coach either—

- (i) there shall be provided padding to a depth of not less than 50mm, on that part of the surface or edge of any bar, or the top or edge of any screen or partition, which would be likely to be struck by the head of a passenger wearing the lap belt in the event of an accident; or
- (ii) the technical and installation requirements of Annex 4 to ECE Regulation 21 shall be met, in respect of any such bar, screen or partition,

but nothing in sub-paragraph (i) above shall require padding to be provided on any surface more than 1m from the centre of the line of intersection of the seat cushion and the back rest or more than 150mm on either side of the longitudinal vertical plane which passes through the centre of that line, nor shall it require padding to be provided on any instrument panel of a minibus.]]

(3) Every seat belt for an adult, other than a disabled person's belt, provided for a vehicle in accordance with [<sup>F321</sup>any of paragraphs (2)(b) to (j)] shall, except as provided in paragraph (6), comply with the installation requirements specified in paragraph 3.2.2 to 3.3.4 of Annex I to Community Directive 77/541 [<sup>F321</sup>, 82/319, 90/628, 96/36 or 2000/3] whether or not [<sup>F322</sup>those Directives apply] to the vehicle.

(4) The requirements specified in paragraph (2) do not apply—

- (a) to a vehicle while it is being used under a trade licence within the meaning of [<sup>F323</sup>section 11 of the Vehicle Excise and Registration Act 1994];
- (b) to a vehicle, not being a vehicle to which the Type Approval (Great Britain) Regulations apply, while it is being driven from premises of the manufacturer by whom it was made, or of a distributor of vehicles or dealer in vehicles—
  - (i) to premises of a distributor of or dealer in vehicles or of the purchaser of the vehicle, or
  - (ii) to premises of a person obtaining possession of the vehicle under a hiring agreement or hire-purchase agreement;
- (c) in relation to any seat for which there is provided—
  - (i) a seat belt which bears a mark including the specification number of the British Standard for Passive Belt Systems, namely BS AU 183:1983 and including the registered certification trade mark of the British Standards Institution; <sup>F324</sup>...
  - (ii) a seat belt designed for use by an adult which is a harness belt comprising a lap belt and shoulder straps which bears a British Standard mark or a mark including the specification number for the British Standard for Seat Belt Assemblies for Motor Vehicles, namely BS 3254:1960 [<sup>F325</sup>or [<sup>F326</sup>BS 3254: Part 1: 1988]] and including the registered certification trade mark of the British Standards Institution, or [<sup>F327</sup>the marking designated as an approval mark by regulation 4 of the Approval Marks Regulations and shown at item 16 or 16A in Schedule 2 to those Regulations];
  - [<sup>F328</sup>(iii) a seat belt which satisfies the requirements of a standard corresponding to the British Standard referred to in sub-paragraph (i); or
  - (iv) a seat belt designed for use by an adult which is a harness belt comprising a lap belt and shoulder straps and which satisfies the requirements of a standard corresponding to any of the British Standards referred to in sub-paragraph (ii).]
- (d) in relation to the driver's seat or the specified passenger's seat (if any) of a vehicle which has been specially designed and constructed, or specially adapted, for the use of a person

**Status:** Point in time view as at 31/03/2009.

**Status:** This revised version has been created from an electronic version contributed by Westlaw which was originally derived from the printed publication. **Read more** (See end of Document for details)**Changes to legislation:** There are currently no known outstanding effects for the The Road Vehicles (Construction and Use) Regulations 1986. (See end of Document for details)

suffering from some physical defect or disability, in a case where a disabled person's belt for an adult person is provided for use for that seat.

[<sup>F329</sup>(e) to a vehicle to which [<sup>F330</sup>item 4 of the Table in regulation 46(3)] applies.]

[<sup>F331</sup>(4A) Vehicles constructed or adapted for the secure transport of prisoners shall not be required to comply with the requirements of paragraph (2) in relation to seats for persons other than the driver and any front seat passenger provided that those seats shall have seat belt anchorage points provided for them in accordance with regulation 46.]

(5) Every seat belt provided in pursuance of paragraph (2) shall be properly secured to the anchorage points provided for it in accordance with regulation 46; or, in the case of a child restraint, to anchorages specially provided for it or, in the case of a disabled person's belt [<sup>F332</sup>first fitted before 1st October 2001], secured to the vehicle or to the seat which is being occupied by the person wearing the belt.

(6) Paragraph (3), in so far as it relates to the second paragraph of paragraph 3.3.2 of the Annex there mentioned (which concerns the locking or releasing of a seat belt by a single movement) does not apply in respect of a seat belt fitted for—

- (a) a seat which is treated as a specified passenger's seat by virtue of the provisions of sub-paragraph (ii) in the definition of “specified passenger's seat” in paragraph (8); or
- (b) any forward-facing seat for a passenger alongside the driver's seat of a goods vehicle which has an unladen weight of more than 915 kg and has more than one such seat, any such seats for passengers being joined together in a single structure.

[<sup>F333</sup>(c) any seat (other than the driver's seat) fitted to a coach.]

(7) Every seat belt, other than a disabled person's belt or a seat belt of a kind mentioned in paragraph [<sup>F334</sup>(4)(c)] above, provided for any person in a vehicle to which this regulation applies shall be legibly and permanently marked—

- (a) <sup>F335</sup>... with a British Standard mark or a designated approval mark [<sup>F336</sup>; or
- (b) with an EC Component Type-Approval Mark complying with Annex III to Community Directive 2000/3].

Provided this paragraph shall not operate so as to invalidate the exception permitted in paragraph (6).

[<sup>F337</sup>(7A) Paragraph (7) does not apply to—

- (a) a seat belt for an adult <sup>F338</sup>... that satisfies the requirements of a standard corresponding to either of the British Standards referred to in sub-paragraph (i)(a) of the definition of “British Standard mark” in paragraph (8); or
- (b) a child restraint that satisfies the requirements of a standard corresponding to any of the British Standards referred to in sub-paragraph (i)(b) of that definition.

(7B) For the purposes of this regulation a reference to a standard corresponding to a specified British Standard is a reference to—

- (a) a standard or code of practice of a national standards body or equivalent body of any EEA State;
- (b) any international standard recognised for use as a standard by any EEA State; or
- (c) a technical specification recognised for use as a standard by a public authority of any EEA State,

where the standard, code of practice, international standard or technical specification provides in relation to seat belts, a level of safety equivalent to that provided by the British Standard and contains a requirement as respects the marking of seat belts equivalent to that provided by the British Standard.

(7C) For the purposes of paragraph (7B)—

**Status:** This revised version has been created from an electronic version contributed by Westlaw which was originally derived from the printed publication. **Read more** (See end of Document for details)**Changes to legislation:** There are currently no known outstanding effects for the The Road Vehicles (Construction and Use) Regulations 1986. (See end of Document for details)

- (a) “EEA State” means a State which is a contracting Party to the EEA Agreement but, until the EEA Agreement comes into force in relation to Liechtenstein, does not include the state of Liechtenstein; and
- (b) “EEA Agreement” means the Agreement on the European Economic Area signed at Oporto on 2nd May 1992 as adjusted by the Protocol signed at Brussels on 17th March 1993.]
- (8) In this regulation—
- “body-restraining<sup>F339</sup> ... belt” means a seat belt designed to provide restraint for both the upper and lower parts of the trunk of the wearer in the event of an accident to the vehicle;
- “British Standard mark” means a mark consisting of—
- (i) the specification number of one of the following British Standards for Seat Belt Assemblies for Motor Vehicles, namely—
- (a) if it is a seat belt for an adult, BS 3254; 1960 [<sup>F340</sup>or BS 3254: Part 1: 1988]; or
- (b) if it is a child restraint, BS 3254:1960 [<sup>F341</sup>or BS 3254: 1960 as amended by Amendment No. 16 published on 31st July 1986 under the number AMD 5210], [<sup>F342</sup>BS 3254: Part 2: 1988][<sup>F343</sup>or BS 3254: Part 2: 1991], BS AU 185, BS AU 186 or 186a, BS AU 202 [<sup>F344</sup>, BS AU 202a or BS AU 202b]; and, in either case,
- (ii) the registered certification trade mark of the British Standards Institution;
- “child restraint” means a seat belt for the use of a young person which is designed either to be fitted directly to a suitable anchorage or to be used in conjunction with a seat belt for an adult and held in place by the restraining action of that belt: Provided that for the purposes of paragraph (2) (c)(ii)(B) and (2)(c)(iii) it means only such seat belts fitted directly to a suitable anchorage and excludes belts marked with the specification numbers BS AU 185 and BS AU 186 or 186a.
- [<sup>F345</sup>“crew seat” has the same meaning as in regulation 3(1) of the Public Service Vehicles (Conditions of Fitness, Equipment, Use and Certification) Regulations 1981;]
- “designated approval mark” means
- (a) if it is a seat belt other than a child restraint, the marking designated as an approval mark by regulation 4 of the Approval Marks Regulations and shown at [<sup>F346</sup>items 16 and 16A] of Schedule 2 to those Regulations or the marking designated as an approval mark by regulation 5 of those Regulations and shown at item 23 [<sup>F347</sup>, 23A and 23B] in Schedule 4 to those Regulations, and
- (b) if it is a child restraint, [<sup>F348</sup>any] of the markings designated as approval marks by regulation 4 of those Regulations and shown at [<sup>F348</sup>items 44, 44A [<sup>F349</sup>, 44B and 44C]] in Schedule 2 to those Regulations.
- “disabled person's belt” means a seat belt which has been specially designed or adapted for use by an adult or young person suffering from some physical defect or disability and which is intended for use solely by such a person;
- [<sup>F345</sup>“exposed forward-facing seat” means—
- (i) a forward-facing front seat (including any crew seat) and the driver’s seat; and
- (ii) any other forward-facing seat which is not immediately behind and on the same horizontal plane as a forward-facing high-backed seat;]
- [<sup>F345</sup>“forward-facing front seat” means—
- (i) any forward-facing seat alongside the driver’s seat; or

**Status:** Point in time view as at 31/03/2009.

**Status:** This revised version has been created from an electronic version contributed by Westlaw which was originally derived from the printed publication. **Read more** (See end of Document for details) **Changes to legislation:** There are currently no known outstanding effects for the The Road Vehicles (Construction and Use) Regulations 1986. (See end of Document for details)

- (ii) if the vehicle normally has no seat which is a forward-facing front seat under subparagraph (i) of this definition, each forward-facing seat for a passenger which is foremost in the vehicle;]

“forward-facing seat” means a seat which is attached to a vehicle so that it faces towards the front of the vehicle in such a manner that a line passing through the centre of both the front and the back of the seat is at an angle of 30° or less to the longitudinal axis of the vehicle;

[<sup>F345</sup>“forward-facing high-backed seat” means a forward-facing seat which is also a high-backed seat;]

[<sup>F345</sup>“high-backed seat” means a seat the highest part of which is at least 1 metre above the deck of the vehicle.]

“inertia reel belt” means a three-point belt of either of the types required for a front outboard seating position by paragraph 3.1.1. of Annex 1 to Community Directive 77/541;

“lap belt” means a seat belt which passes across the front of the wearer’s pelvic region<sup>F350</sup> and which is designed for use by an adult];

[<sup>F351</sup>“retractable lap belt” means a lap belt with either an automatically locking retractor (as defined in paragraph 1.8.3 of Annex I to Community Directive 77/541) or an emergency locking retractor (as defined in paragraph 1.8.4 of Annex I to Community Directive 77/541)];

“seat” includes any part designed for the accommodation of one adult of a continuous seat designed for the accommodation of more than one adult;

“seat belt” means a belt intended to be worn by a person in a vehicle and designed to prevent or lessen injury to its wearer in the event of an accident to the vehicle and includes, in the case of a child restraint, any special chair to which the belt is attached;

“specified passenger’s seat” means—

- (i) in the case of a vehicle which has one forward-facing front seat alongside the driver’s seat, that seat, and in the case of a vehicle which has more than one such seat, the one furthest from the driver’s seat; or
- (ii) if the vehicle normally has no seat which is the specified passenger’s seat under subparagraph (i) of this definition the forward-facing front seat for a passenger which is foremost in the vehicle and furthest from the driver’s seat, unless there is a fixed partition separating that seat from the space in front of it alongside the driver’s seat;

and

“three-point belt” means a seat belt which—

- (i) restrains the upper and lower parts of the torso;
- (ii) includes a lap belt;
- (iii) is anchored at not less than three points; and
- (iv) is designed for use by an adult.

#### Textual Amendments

**F312** Word in reg. 47(2)(a) omitted (31.7.1987) by virtue of [The Road Vehicles \(Construction and Use\) \(Amendment\) \(No.2\) Regulations 1987 \(S.I. 1987/1133\)](#), regs. 1, **6(a)(i)**

**F313** Word in reg. 47(2)(b) omitted (31.7.1987) by virtue of [The Road Vehicles \(Construction and Use\) \(Amendment\) \(No.2\) Regulations 1987 \(S.I. 1987/1133\)](#), regs. 1, **6(a)(ii)**

**F314** Words in reg. 47(2)(c) substituted (1.10.2001) by [The Road Vehicles \(Construction and Use\) \(Amendment\) \(No. 2\) Regulations 2001 \(S.I. 2001/1043\)](#), regs. 1, **4(2)(a)**

**Status:** This revised version has been created from an electronic version contributed by Westlaw which was originally derived from the printed publication. **Read more** (See end of Document for details)**Changes to legislation:** There are currently no known outstanding effects for the The Road Vehicles (Construction and Use) Regulations 1986. (See end of Document for details)

- F315** Reg. 47(2)(d)(e) inserted (31.7.1987) by The Road Vehicles (Construction and Use) (Amendment) (No.2) Regulations 1987 (S.I. 1987/1133), regs. 1, **6(a)(iv)**
- F316** Words in reg. 47(2)(d) substituted (1.10.2001) by The Road Vehicles (Construction and Use) (Amendment) (No. 2) Regulations 2001 (S.I. 2001/1043), regs. 1, **4(2)(b)**
- F317** Words in reg. 47(2)(e) substituted (1.10.2001) by The Road Vehicles (Construction and Use) (Amendment) (No. 2) Regulations 2001 (S.I. 2001/1043), regs. 1, **4(2)(d)**
- F318** Reg. 47(2)(f)-(j) inserted (1.10.2001) by The Road Vehicles (Construction and Use) (Amendment) (No. 2) Regulations 2001 (S.I. 2001/1043), regs. 1, **4(2)(e)**
- F319** Words in reg. 47(2) inserted (31.7.1987) by The Road Vehicles (Construction and Use) (Amendment) (No.2) Regulations 1987 (S.I. 1987/1133), regs. 1, **6(a)(v)**
- F320** Words in reg. 47(2) substituted (7.9.1989) by The Road Vehicles (Construction and Use) (Amendment) Regulations 1989 (S.I. 1989/1478), regs. 1, **4(2)** (with reg. 2(2))
- F321** Words in reg. 47(3) substituted (1.10.2001) by The Road Vehicles (Construction and Use) (Amendment) (No. 2) Regulations 2001 (S.I. 2001/1043), regs. 1, **4(3)**
- F322** Words in reg. 47(3) substituted (7.10.1991) by The Road Vehicles (Construction and Use) (Amendment) (No. 3) Regulations 1991 (S.I. 1991/2003), regs. 1, **5(2)**
- F323** Words in reg. 47(4)(a) substituted (1.10.2001) by The Road Vehicles (Construction and Use) (Amendment) (No. 2) Regulations 2001 (S.I. 2001/1043), regs. 1, **4(4)(a)**
- F324** Word in reg. 47(4)(c) omitted (1.2.1995) by virtue of The Road Vehicles (Construction and Use) (Amendment) (No.3) Regulations 1994 (S.I. 1994/3270), regs. 1, **4(2)(b)**
- F325** Words in reg. 47(4)(c)(ii) inserted (31.7.1987) by The Road Vehicles (Construction and Use) (Amendment) (No.2) Regulations 1987 (S.I. 1987/1133), regs. 1, **6(c)(i)**
- F326** Words in reg. 47(4)(c)(ii) substituted (7.9.1989) by The Road Vehicles (Construction and Use) (Amendment) Regulations 1989 (S.I. 1989/1478), regs. 1, **4(3)** (with reg. 2(2))
- F327** Words in reg. 47(4)(c)(ii) substituted (1.2.1995) by The Road Vehicles (Construction and Use) (Amendment) (No.3) Regulations 1994 (S.I. 1994/3270), regs. 1, **4(2)(a)**
- F328** Reg. 47(4)(c)(iii)(iv) added (1.2.1995) by The Road Vehicles (Construction and Use) (Amendment) (No.3) Regulations 1994 (S.I. 1994/3270), regs. 1, **4(2)(b)**
- F329** Reg. 47(4)(e) inserted (31.7.1987) by The Road Vehicles (Construction and Use) (Amendment) (No.2) Regulations 1987 (S.I. 1987/1133), regs. 1, **6(c)(ii)**
- F330** Words in reg. 47(4)(e) substituted (1.10.2001) by The Road Vehicles (Construction and Use) (Amendment) (No. 2) Regulations 2001 (S.I. 2001/1043), regs. 1, **4(4)**
- F331** Reg. 47(4A) inserted (1.10.2001) by The Road Vehicles (Construction and Use) (Amendment) (No. 2) Regulations 2001 (S.I. 2001/1043), regs. 1, **4(5)**
- F332** Words in reg. 47(5) substituted (1.10.2001) by The Road Vehicles (Construction and Use) (Amendment) (No. 2) Regulations 2001 (S.I. 2001/1043), regs. 1, **4(6)**
- F333** Reg. 47(6)(c) added (31.7.1987) by The Road Vehicles (Construction and Use) (Amendment) (No.2) Regulations 1987 (S.I. 1987/1133), regs. 1, **6(d)**
- F334** Word in reg. 47(7) substituted (1.2.1995) by The Road Vehicles (Construction and Use) (Amendment) (No.3) Regulations 1994 (S.I. 1994/3270), regs. 1, **4(3)**
- F335** Words in reg. 47(7)(a) omitted (6.3.1996) by virtue of The Road Vehicles (Construction and Use) (Amendment) (No.2) Regulations 1996 (S.I. 1996/163), regs. 2, **4(2)(a)**
- F336** Reg. 47(7)(b) and word inserted (1.10.2001) by The Road Vehicles (Construction and Use) (Amendment) (No. 2) Regulations 2001 (S.I. 2001/1043), regs. 1, **4(7)**
- F337** Reg. 47(7A)-(7C) inserted (1.2.1995) by The Road Vehicles (Construction and Use) (Amendment) (No.3) Regulations 1994 (S.I. 1994/3270), regs. 1, **4(4)**
- F338** Words in reg. 47(7A)(a) omitted (6.3.1996) by virtue of The Road Vehicles (Construction and Use) (Amendment) (No.2) Regulations 1996 (S.I. 1996/163), regs. 2, **4(3)**
- F339** Word in reg. 47(8) omitted (31.7.1987) by virtue of The Road Vehicles (Construction and Use) (Amendment) (No.2) Regulations 1987 (S.I. 1987/1133), regs. 1, **6(e)(i)**
- F340** Words in reg. 47(8) substituted (7.9.1989) by The Road Vehicles (Construction and Use) (Amendment) Regulations 1989 (S.I. 1989/1478), regs. 1, **4(4)(a)** (with reg. 2(2))

**Status:** Point in time view as at 31/03/2009.

**Status:** This revised version has been created from an electronic version contributed by Westlaw which was originally derived from the printed publication. **Read more** (See end of Document for details)**Changes to legislation:** There are currently no known outstanding effects for the The Road Vehicles (Construction and Use) Regulations 1986. (See end of Document for details)

- F341** Words in reg. 47(8) inserted (31.7.1987) by The Road Vehicles (Construction and Use) (Amendment) (No.2) Regulations 1987 (S.I. 1987/1133), regs. 1, **6(e)(ii)**
- F342** Words in reg. 47(8) substituted (7.9.1989) by The Road Vehicles (Construction and Use) (Amendment) Regulations 1989 (S.I. 1989/1478), regs. 1, **4(4)(b)** (with reg. 2(2))
- F343** Words in reg. 47(8) inserted (1.2.1995) by The Road Vehicles (Construction and Use) (Amendment) (No.3) Regulations 1994 (S.I. 1994/3270), regs. 1, **4(5)**
- F344** Words in reg. 47(8) substituted (1.11.1998) by The Road Vehicles (Construction and Use) (Amendment) (No. 6) Regulations 1998 (S.I. 1998/2429), regs. 1, **6(3)(a)**
- F345** Words in reg. 47(8) inserted (31.7.1987) by The Road Vehicles (Construction and Use) (Amendment) (No.2) Regulations 1987 (S.I. 1987/1133), regs. 1, **6(e)(iv)**
- F346** Words in reg. 47(8) substituted (7.9.1989) by The Road Vehicles (Construction and Use) (Amendment) Regulations 1989 (S.I. 1989/1478), regs. 1, **4(4)(c)(i)** (with reg. 2(2))
- F347** Words in reg. 47(8) substituted (7.10.1991) by The Road Vehicles (Construction and Use) (Amendment) (No. 3) Regulations 1991 (S.I. 1991/2003), regs. 1, **5(3)**
- F348** Words in reg. 47(8) substituted (7.9.1989) by The Road Vehicles (Construction and Use) (Amendment) Regulations 1989 (S.I. 1989/1478), regs. 1, **4(4)(c)(ii)** (with reg. 2(2))
- F349** Words in reg. 47(8) substituted (1.11.1998) by The Road Vehicles (Construction and Use) (Amendment) (No. 6) Regulations 1998 (S.I. 1998/2429), regs.1, **6(3)(b)**
- F350** Words in reg. 47(8) added (31.7.1987) by The Road Vehicles (Construction and Use) (Amendment) (No.2) Regulations 1987 (S.I. 1987/1133), regs. 1, **6(e)(iii)**
- F351** Words in reg. 47(8) substituted (1.10.2001) by The Road Vehicles (Construction and Use) (Amendment) (No. 2) Regulations 2001 (S.I. 2001/1043), regs. 1, **4(8)**

#### Commencement Information

- I41** Reg. 47 in force at 11.8.1986, see [reg. 1](#)

### Maintenance of seat belts and anchorage points

**48.**—(1) This regulation applies to every seat belt with which a motor vehicle is required to be provided in accordance with regulation 47 and to the anchorages, fastenings, adjusting device and retracting mechanism (if any) of every such seat belt [<sup>F352</sup>and also to every anchorage with which a goods vehicle is required to be provided in accordance with [<sup>F353</sup>regulation 46(3) and item 4 in the Table in that regulation]].

(2) For the purposes of this regulation the anchorages and anchorage points of a seat belt shall, in the case of a seat which incorporates integral seat belt anchorages, include the system by which the seat assembly itself is secured to the vehicle structure.

(3) The anchorage points provided for seat belts shall be used only as anchorages for the seat belts for which they are intended to be used or capable of being used.

(4) Save as provided in paragraph (5) below—

- (a) all load-bearing members of the vehicle structure or panelling within 30 cms of each anchorage point shall be maintained in a sound condition and free from serious corrosion, distortion or fracture;
- (b) the adjusting device and (if fitted) the retracting mechanism of the seat belt shall be so maintained that the belt may be readily adjusted to the body of the wearer, either automatically or manually, according to the design of the device and (if fitted) the retracting mechanism;
- (c) the seat belt and its anchorages, fastenings and adjusting device shall be maintained free from any obvious defect which would be likely to affect adversely the performance by the seat belt of the function of restraining the body of the wearer in the event of an accident to the vehicle;

- (d) the buckle or other fastening of the seat belt shall—
    - (i) be so maintained that the belt can be readily fastened or unfastened;
    - (ii) be kept free from any temporary or permanent obstruction; and
    - (iii) except in the case of a disabled person's seat belt, be readily accessible to a person sitting in the seat for which the seat belt is provided;
  - (e) the webbing or other material which forms the seat belt shall be maintained free from cuts or other visible faults (as, for example, extensive fraying) which would be likely to affect adversely the performance of the belt when under stress;
  - (f) the ends of every seat belt, other than a disabled person's seat belt, shall be securely fastened to the anchorage points provided for them; and
  - (g) the ends of every disabled person's seat belt shall, when the seat belt is being used for the purpose for which it was designed and constructed, be securely fastened either to some part of the structure of the vehicle or to the seat which is being occupied by the person wearing the belt so that the body of the person wearing the belt would be restrained in the event of an accident to the vehicle.
- (5) No requirement specified in paragraph (4) above applies if the vehicle is being used—
- (a) on a journey after the start of which the requirement ceased to be complied with; or
  - (b) after the requirement ceased to be complied with and steps have been taken for such compliance to be restored with all reasonable expedition.
- (6) Expressions which are used in this regulation and are defined in regulation 47 have the same meaning in this regulation as they have in regulation 47.

#### Textual Amendments

**F352** Words in [reg. 48\(1\)](#) added (31.7.1987) by [The Road Vehicles \(Construction and Use\) \(Amendment\) \(No.2\) Regulations 1987 \(S.I. 1987/1133\)](#), regs. 1, 7

**F353** Words in [reg. 48\(1\)](#) substituted (1.10.2001) by [The Road Vehicles \(Construction and Use\) \(Amendment\) \(No. 2\) Regulations 2001 \(S.I. 2001/1043\)](#), regs. 1, **5(2)**

#### Commencement Information

**I42** [Reg. 48](#) in force at 11.8.1986, see [reg. 1](#)

### <sup>F354</sup> **Minibuses and coaches to be fitted with additional seat belts when used in certain circumstances**

**48A.**—(1) No person shall use or cause or permit to be used on a road a coach or minibus wholly or mainly for the purpose of carrying a group of 3 or more children in the following circumstances unless the appropriate number of forward-facing passenger seats fitted to the vehicle meet the requirements of this regulation.

(2) The circumstances are that—

- (a) the group of children are on an organised trip; and
- (b) the journey is being made for the purposes of the trip.

(3) In paragraph (1), the reference to the appropriate number is a reference to the number of children being carried in the vehicle (excluding disabled children in wheelchairs).

<sup>F355</sup> (3A) For the purposes of this regulation a rearward-facing seat shall be treated as a forward-facing seat which meets the requirements of this regulation if the coach or minibus concerned was

**Status:** Point in time view as at 31/03/2009.

**Status:** This revised version has been created from an electronic version contributed by Westlaw which was originally derived from the printed publication. **Read more** (See end of Document for details)**Changes to legislation:** There are currently no known outstanding effects for the The Road Vehicles (Construction and Use) Regulations 1986. (See end of Document for details)

first used on or after 1st October 2001, and the rearward-facing seat complies with the requirements of regulations 46 and 47.]

(4) Without prejudice to the generality of paragraph (2)(a), a group of children shall, for the purposes of this regulation, be regarded as being on an organised trip if they are being carried to or from their school or from one part of their school premises to another.

(5) Without prejudice to the meaning of paragraph (2)(b), paragraph (1) shall not apply to a vehicle if it is being used in the provision of a bus service of a description specified in paragraph 2 of the Schedule to the Fuel Duty Grant (Eligible Bus Services) Regulations 1985 or if it is otherwise being used wholly or mainly for the purpose of providing a transport service for the general public.

(6) For a forward-facing passenger seat to meet the requirements of this regulation a seat belt must be provided for it, and —

- (a) if paragraph (3) of regulation 47 does not (in whole or part) apply to the seat belt and the seat belt was first fitted to the vehicle after 10th February 1997, the seat belt must comply with that paragraph to the extent (if any) that it would have to so comply were—
  - (i) that regulation to apply to all motor vehicles, and
  - (ii) there substituted for the words “provided” to “or (e)”, in that paragraph, the words “provided for any person in a vehicle to which this regulation applies”;
- (b) if paragraph (5) of regulation 47 does not apply to the seat belt and the seat belt is a seat belt for an adult (not being a disabled person’s belt) that was first fitted to the vehicle after 10th February 1997, the seat belt must comply with the requirements specified in paragraph (7) below;
- (c) if paragraph (5) of regulation 47 does not apply to the seat belt and the seat belt is a child restraint that was first fitted to the vehicle after 10th February 1997, the seat belt must be properly secured to anchorages provided for it;
- (d) if paragraph (5) of regulation 47 does not apply to the seat belt and the seat belt is a disabled person’s belt that was first fitted to the vehicle after 10th February 1997, the seat belt must be properly secured to the vehicle or to the seat;
- (e) if regulation 47 does not apply to the vehicle and the seat belt was first fitted to the vehicle after 10th February 1997, the seat belt must comply with paragraph (7) of that regulation to the extent (if any) that it would have to so comply were that regulation to apply to all motor vehicles; and
- (f) if regulation 48 does not apply to the seat belt and the seat belt was first fitted to the vehicle after 10th February 1997, the requirements of paragraph (4) of that regulation must be met in relation to the anchorages, fastenings, adjusting device and retracting mechanism (if any) of the seat belt to the extent (if any) that those requirements would have to be met were that paragraph to apply to all anchorages, fastenings, adjusting devices and retracting mechanisms of seat belts fitted to motor vehicles,

and paragraph (2) of regulation 48 shall apply for the purposes of sub-paragraph (f) above as it applies for the purposes of that regulation.

(7) The requirements referred to in paragraph (6)(b) are that the seat belt must be properly secured to the anchorage points provided for it and, in a case where any of those anchorage points is first fitted to the vehicle after 10th February 1997 the anchorage points to which it is secured must comply—

- (a) if the vehicle is a coach, with the requirements specified in regulation 46(4)(b) or (4A)(b)(ii); or
- (b) in any other case, with the requirements specified in regulation 46(4)(b).

(8) Until 10th February 1998, this regulation shall not apply to a coach first used before 1st October 1988.



**Status:** This revised version has been created from an electronic version contributed by Westlaw which was originally derived from the printed publication. **Read more** (See end of Document for details)**Changes to legislation:** There are currently no known outstanding effects for the The Road Vehicles (Construction and Use) Regulations 1986. (See end of Document for details)

(9) In this regulation—

“school” has the meaning given by section 14(5) of the Further and Higher Education Act 1992;  
“forward-facing passenger seat” means a forward-facing seat which is not the driver’s seat; and  
“child restraint”, “disabled person’s belt”, “forward-facing seat”, “seat”, and “seat belt” have the meanings given in regulation 47.

(10) For the purpose of this regulation, a child is a person who is aged 3 years or more but is under the age of 16 years.]

#### Textual Amendments

**F354** Reg. 48A inserted (10.2.1997) by [The Road Vehicles \(Construction and Use\) \(Amendment\) \(No.2\) Regulations 1996 \(S.I. 1996/163\)](#), regs. 2, 5

**F355** Reg. 48A(3A) inserted (1.10.2001) by [The Road Vehicles \(Construction and Use\) \(Amendment\) \(No. 2\) Regulations 2001 \(S.I. 2001/1043\)](#), regs. 1, 6(2)

#### Rear under-run protection

**49.**—(1) Save as provided in paragraph (2), this regulation applies to a wheeled goods vehicle being either—

- (a) a motor vehicle with a maximum gross weight which exceeds 3500 kg and which was first used on or after 1st April 1984; or
- (b) a trailer manufactured on or after 1st May 1983 with an unladen weight which exceeds 1020 kg.

(2) This regulation does not apply to—

- (a) a motor vehicle which has a maximum speed not exceeding 15 mph;
- (b) a motor car or a heavy motor car constructed or adapted to form part of an articulated vehicle;
- (c) an agricultural trailer;
- (d) engineering plant;
- (e) a fire engine;
- (f) an agricultural motor vehicle;
- (g) a vehicle fitted at the rear with apparatus specially designed for spreading material on a road;
- (h) a vehicle so constructed that it can be unloaded by part of the vehicle being tipped rearwards;
- (i) a vehicle owned by the Secretary of State for Defence and used for naval, military or air force purposes;
- (j) a vehicle to which no bodywork has been fitted and which is being driven or towed—
  - (i) for the purpose of a quality or safety check by its manufacturer or a dealer in, or distributor of, such vehicles; or
  - (ii) to a place where, by previous arrangement, bodywork is to be fitted or work preparatory to the fitting of bodywork is to be carried out; or
  - (iii) by previous arrangement to premises of a dealer in, or distributor of, such vehicles;
- (k) a vehicle which is being driven or towed to a place where by previous arrangement a device is to be fitted so that it complies with this regulation;

**Status:** Point in time view as at 31/03/2009.

**Status:** This revised version has been created from an electronic version contributed by Westlaw which was originally derived from the printed publication. **Read more** (See end of Document for details) **Changes to legislation:** There are currently no known outstanding effects for the The Road Vehicles (Construction and Use) Regulations 1986. (See end of Document for details)

- (l) a vehicle specially designed and constructed, and not merely adapted, to carry other vehicles loaded onto it from the rear;
- (m) a trailer specially designed and constructed, and not merely adapted, to carry round timber, beams or girders, being items of exceptional length;
- (n) a vehicle fitted with a tail lift so constructed that the lift platform forms part of the floor of the vehicle and this part has a length of at least 1 m measured parallel to the longitudinal axis of the vehicle;
- (o) a trailer having a base or centre in a country outside Great Britain from which it normally starts its journeys, provided that a period of not more than 12 months has elapsed since the vehicle was last brought into Great Britain;
- (p) a vehicle specially designed, and not merely adapted, for the carriage and mixing of liquid concrete;
- (q) a vehicle designed and used solely for the delivery of coal by means of a special conveyor which is carried on the vehicle and when in use is fitted to the rear of the vehicle so as to render its being equipped with a rear under-run protective device impracticable; or
- (r) an agricultural trailed appliance.

(3) Subject to the provisions of paragraphs (4), (5) and (6), every vehicle to which this regulation applies shall be equipped with a rear under-run protective device.

(4) A vehicle to which this regulation applies and which is fitted with a tail lift, bodywork or other part which renders its being equipped with a rear under-run protective device impracticable shall instead be equipped with one or more devices which do not protrude beyond the overall width of the vehicle (excluding any part of the device or the devices) and which comply with the following requirements—

- (a) where more than one device is fitted, not more than 50 cm shall lie between one device and the device next to it;
- (b) not more than 30 cm shall lie between the outermost end of a device nearest to the outermost part of the vehicle to which it is fitted and a longitudinal plane passing through the outer end of the rear axle of the vehicle on the same side of the vehicle or, in a case where the vehicle is fitted with more than one rear axle, through the outer end of the widest rear axle on the same side of the vehicle, and paragraph II.5.4.2 in the Annex to Community Directive 79/490 shall not have effect in a case where this requirement is met; and
- (c) the device or, where more than one device is fitted, all the devices together, shall have the characteristics specified in paragraphs [F<sup>356</sup>II.5.4.1] to II.5.4.5.5.2 in the Annex to the said Directive save—
  - (i) as provided in sub-paragraphs (a) and (b) above;
  - (ii) that for the reference in paragraph II.5.4.5.1 in that Annex to 30 cm there is substituted a reference to 35 cm; and
  - (iii) that the distance of 40 cm specified in paragraph II.5.4.5 in that Annex may be measured exclusive of the said tail-lift, bodywork or other part.

(5) The provisions of paragraph (3) shall have effect so that in the case of—

- (a) a vehicle which is fitted with a demountable body, the characteristics specified in paragraph II.5.4.2 in the Annex to the said Directive have effect as if the reference to 10 cm were a reference to 30 cm and as if in paragraph II.5.4.5.1 the reference to 30 cm were a reference to 35 cm; and
- (b) a trailer with a single axle or two close-coupled axles, the height of 55 cm referred to in paragraph II.5.4.5.1 in that Annex is measured when the coupling of the trailer to the

vehicle by which it is drawn is at the height recommended by the manufacturer of the trailer.

(6) Instead of complying with paragraphs (3) to (5) a vehicle may comply with [F357 Community Directive 97/19].

(7) In this regulation—

“rear under-run protective device” means a device within the description given in paragraph II.5.4 in the Annex to Community Directive 79/490.

#### Textual Amendments

**F356** Word in reg. 49(4)(c) substituted (6.5.1987) by [The Road Vehicles \(Construction and Use\) \(Amendment\) Regulations 1987 \(S.I. 1987/676\)](#), regs. 1(2), **15(3)**

**F357** Words in reg. 49(6) substituted (1.6.1998) by [The Road Vehicles \(Construction and Use\) \(Amendment\) \(No. 3\) Regulations 1998 \(S.I. 1998/1188\)](#), regs. 1, **12**

#### Commencement Information

**I43** [Reg. 49](#) in force at 11.8.1986, see [reg. 1](#)

### Maintenance of rear under-run protective device

**50.** Every device fitted to a vehicle in compliance with the requirements of regulation 49 shall at all times when the vehicle is on a road be maintained free from any obvious defect which would be likely to affect adversely the performance of the device in the function of giving resistance in the event of an impact from the rear.

#### Commencement Information

**I44** [Reg. 50](#) in force at 11.8.1986, see [reg. 1](#)

### Sideguards

**51.**—(1) Save as provided in paragraph (2), this regulation applies to a wheeled goods vehicle being—

- (a) a motor vehicle first used on or after 1st April 1984 with a maximum gross weight which exceeds 3500 kg; or
- (b) a trailer manufactured on or after 1st May 1983 with an unladen weight which exceeds 1020 kg; or
- (c) a semi-trailer manufactured before 1st May 1983 which has a relevant plate showing a gross weight exceeding 26,000 kg and which forms part of an articulated vehicle with a relevant train weight exceeding 32,520 kg.

(2) This regulation does not apply to—

- (a) a motor vehicle which has a maximum speed not exceeding 15 mph;
- (b) an agricultural trailer;
- (c) engineering plant;
- (d) a fire engine;
- (e) an agricultural motor vehicle;

**Status:** Point in time view as at 31/03/2009.

**Status:** This revised version has been created from an electronic version contributed by Westlaw which was originally derived from the printed publication. **Read more** (See end of Document for details) **Changes to legislation:** There are currently no known outstanding effects for the The Road Vehicles (Construction and Use) Regulations 1986. (See end of Document for details)

- (f) a vehicle so constructed that it can be unloaded by part of the vehicle being tipped sideways or rearwards;
- (g) a vehicle owned by the Secretary of State for Defence and used for naval, military or air force purposes;
- (h) a vehicle to which no bodywork has been fitted and which is being driven or towed—
  - (i) for the purpose of a quality or safety check by its manufacturer or a dealer in, or distributor of, such vehicles;
  - (ii) to a place where, by previous arrangement, bodywork is to be fitted or work preparatory to the fitting of bodywork is to be carried out; or
  - (iii) by previous arrangement to premises of a dealer in, or distributor of, such vehicles;
- (i) a vehicle which is being driven or towed to a place where by previous arrangement a sideguard is to be fitted so that it complies with this regulation;
- (j) a refuse vehicle;
- (k) a trailer specially designed and constructed, and not merely adapted, to carry round timber, beams or girders, being items of exceptional length;
- (l) a motor car or a heavy motor car constructed or adapted to form part of an articulated vehicle;
- (m) a vehicle specially designed and constructed, and not merely adapted, to carry other vehicles loaded onto it from the front or the rear;
- (n) a trailer with a load platform—
  - (i) no part of any edge of which is more than 60 mm inboard from the tangential plane; and
  - (ii) the upper surface of which is not more than 750 mm from the ground throughout that part of its length under which a sideguard would have to be fitted in accordance with paragraph (5)(d) to (g) if this exemption did not apply to it;
- (o) a trailer having a base or centre in a country outside Great Britain from which it normally starts its journeys, provided that a period of not more than 12 months has elapsed since the vehicle was last brought into Great Britain; or
- (p) an agricultural trailed appliance.

[<sup>F358</sup>(2A) This regulation also applies to a wheeled goods vehicle, whether of a description falling within paragraph (2) or not, which is a semi-trailer some or all of the wheels of which are driven by the drawing vehicle.]

(3) Every vehicle to which this regulation applies shall be securely fitted with a sideguard to give protection on any side of the vehicle where—

- (a) if it is a semi-trailer, the distance between the transverse planes passing through the centre of its foremost axle and through the centre of its king pin or, in the case of a vehicle having more than one king pin, the rearmost one, exceeds 4.5 m; or
- (b) if it is any other vehicle, the distance between the centres of any two consecutive axles exceeds 3 m.

(4) Save as provided in paragraphs (6) and (7), a sideguard with which a vehicle is by this regulation required to be fitted shall comply with all the specifications listed in paragraph (5).

(5) Those specifications are—

- (a) the outermost surface of every sideguard shall be smooth, essentially rigid and either flat or horizontally corrugated, save that—

- (i) any part of the surface may overlap another provided that the overlapping edges face rearwards or downwards;
- (ii) a gap not exceeding 25 mm measured longitudinally may exist between any two adjacent parts of the surface provided that the foremost edge of the rearward part does not protrude outboard of the rearmost edge of the forward part; and
- (iii) domed heads of bolts or rivets may protrude beyond the surface to a distance not exceeding 10 mm;
- (b) no part of the lowest edge of a sideguard shall be more than 550 mm above the ground when the vehicle to which it is fitted is on level ground and, in the case of a semi-trailer, when its load platform is horizontal;
- (c) in a case specified in an item in column 2 of the Table the highest edge of a sideguard shall be as specified in that item in column 3;
- (d) the distance between the rearmost edge of a sideguard and the transverse plane passing through the foremost part of the tyre fitted to the wheel of the vehicle nearest to it shall not exceed 300 mm;
- (e) the distance between the foremost edge of a sideguard fitted to a semi-trailer and a transverse plane passing through the centre of the vehicle's king pin or, if the vehicle has more than one king pin, the rearmost one, shall not exceed 3 m;
- (f) the foremost edge of a sideguard fitted to a semi-trailer with landing legs shall, as well as complying with sub-paragraph (e), not be more than 250 mm to the rear of a transverse plane passing through the centre of the leg nearest to that edge;
- (g) the distance between the foremost edge of a sideguard fitted to a vehicle other than a semi-trailer and a transverse plane passing through the rearmost part of the tyre fitted to the wheel of the vehicle nearest to it shall not exceed 300 mm if the vehicle is a motor vehicle and 500 mm if the vehicle is a trailer;
- (h) the external edges of a sideguard shall be rounded at a radius of at least 2.5 mm;
- (i) no sideguard shall be more than 30 mm inboard from the tangential plane;
- (j) no sideguard shall project beyond the longitudinal plane from which, in the absence of a sideguard, the vehicle's overall width would fall to be measured;
- (k) every sideguard shall cover an area extending to at least 100 mm upwards from its lowest edge 100 mm downwards from its highest edge, and 100 mm rearwards and inwards from its foremost edge, and no sideguard shall have a vertical gap measuring more than 300 mm nor any vertical surface measuring less than 100 mm; and
- (l) except in the case of a vehicle described in paragraph (1) (c) every sideguard shall be capable of withstanding a force of 2 kilonewtons applied perpendicularly to any part of its surface by the centre of a ram the face of which is circular and not more than 220 mm in diameter, and during such application—
  - (i) no part of the sideguard shall be deflected by more than 150 mm, and
  - (ii) no part of the sideguard which is less than 250 mm from its rearmost part shall be deflected by more than 30 mm.

## TABLE

(regulation 51(5))

**Status:** Point in time view as at 31/03/2009.

**Status:** This revised version has been created from an electronic version contributed by Westlaw which was originally derived from the printed publication. **Read more** (See end of Document for details)**Changes to legislation:** There are currently no known outstanding effects for the The Road Vehicles (Construction and Use) Regulations 1986. (See end of Document for details)

<i>1</i> <i>Item</i>	<i>2</i> <i>Case</i>	<i>3</i> <i>Requirement about</i> <i>highest edge of sideguard</i>
1	Where the floor of the vehicle to which the sideguard is fitted—  (i) extends laterally outside the tangential plane;  (ii) is not more than 1.85 m from the ground;  (iii) extends laterally over the whole of the length of the sideguard with which the vehicle is required by this regulation to be fitted; and  (iv) is wholly covered at its edge by a side-rave the lower edge of which is not more than 150 mm below the underside of the floor.	Not more than 350 mm below the lower edge of the side-rave.
2	Where the floor of the vehicle to which the sideguard is fitted—  (i) extends laterally outside the tangential plane; and  (ii) does not comply with all of the provisions specified in sub-paragraphs (ii), (iii) and (iv) in item 1 above,  and any part of the structure of the vehicle is cut within 1.85 m of the ground by the tangential plane.	Not more than 350 mm below the structure of the vehicle where it is cut by the tangential plane.
3	Where—  (i) no part of the structure of the vehicle is cut within 1.85 m of the ground by the tangential plane; and  (ii) the upper surface of the load carrying structure of the vehicle is less than 1.5 m from the ground.	Not less than the height of the upper surface of the load carrying structure of the vehicle.
4	A vehicle specially designed, and not merely adapted, for the carriage and mixing of liquid concrete.	Not less than 1 m from the ground.
5	Any other case.	Not less than 1.5 m from the ground.

(6) The provisions of paragraph (4) apply—

- (a) in the case of an extendible trailer when it is, by virtue of the extending mechanism, extended to a length greater than its minimum, so as not to require, in respect of any

- additional distance solely attributable to the extension, compliance with the specifications mentioned in paragraph (5) (d) to (g);
- (b) in the case of a vehicle designed and constructed, and not merely adapted, to be fitted with a demountable body or to carry a container, when it is not fitted with a demountable body or carrying such a container as if it were fitted with such a body or carrying such a container; and
- (c) only so far as it is practicable in the case of—
- (i) a vehicle designed solely for the carriage of a fluid substance in a closed tank which is permanently fitted to the vehicle and provided with valves and hose or pipe connections for loading or unloading; and
- (ii) a vehicle which requires additional stability during loading or unloading or while being used for operations for which it is designed or adapted and is fitted on one or both sides with an extendible device to provide such stability.
- (7) In the case of a motor vehicle to which this regulation applies and which is of a type which was required to be approved by the Type Approval for Goods Vehicles Regulations before 1st October 1983—
- (a) if the bodywork of the vehicle covers the whole of the area specified as regards a sideguard in paragraph (5)(b), (c), (d) and (g) above the other provisions of that paragraph do not apply to that vehicle; and
- (b) if the bodywork of the vehicle covers only part of that area the part of that area which is not so covered shall be fitted with a sideguard which complies with the provisions of paragraph (5) above save that there shall not be a gap between—
- (i) the rearmost edge of the sideguard or the rearmost part of the bodywork (whichever is furthest to the rear) and the transverse plane mentioned in paragraph (5)(d) of more than 300 mm;
- (ii) the foremost edge of the sideguard or the foremost part of the bodywork (whichever is furthest to the front) and the transverse plane mentioned in paragraph (5)(g) of more than 300 mm; or
- (iii) any vertical or sloping edge of any part of the bodywork in question and the edge of the sideguard immediately forwards or rearwards thereof of more than 25 mm measured horizontally.
- (8) In this regulation
- “relevant plate” means a Ministry plate, where fitted, and in other cases a plate fitted in accordance with regulation 66;
- “relevant train weight” means the train weight shown in column 2 of the Ministry plate, where fitted, and in other cases the maximum train weight shown at item 8 of the plate fitted in accordance with regulation 66; and
- “tangential plane”, in relation to a sideguard, means the vertical plane tangential to the external face of the outermost part of the tyre (excluding any distortion caused by the weight of the vehicle) fitted to the outermost wheel at the rear and on the same side of the vehicle.
- [<sup>F359</sup>(9) Instead of complying with the foregoing provisions of this regulation a vehicle may comply with Community Directive 89/297.]

#### Textual Amendments

**F358** Reg. 51(2A) inserted (6.5.1987) by [The Road Vehicles \(Construction and Use\) \(Amendment\) Regulations 1987 \(S.I. 1987/676\)](#), regs. 1(2), 6

**Status:** Point in time view as at 31/03/2009.

**Status:** This revised version has been created from an electronic version contributed by Westlaw which was originally derived from the printed publication. **Read more** (See end of Document for details)**Changes to legislation:** There are currently no known outstanding effects for the The Road Vehicles (Construction and Use) Regulations 1986. (See end of Document for details)

**F359** Reg. 51(9) inserted (30.10.1989) by The Road Vehicles (Construction and Use) (Amendment) (No. 2) Regulations 1989 (S.I. 1989/1695), regs. 1, 3 (with reg. 2(2))

#### Commencement Information

**I45** Reg. 51 in force at 11.8.1986, see **reg. 1**

### Maintenance of sideguards

**52.** Every sideguard fitted to a vehicle in compliance with the requirements of regulation 51 shall at all times when the vehicle is on a road be maintained free from any obvious defect which would be likely to affect adversely its effectiveness.

#### Commencement Information

**I46** Reg. 52 in force at 11.8.1986, see **reg. 1**

### Mascots

**53.**—(1) Subject to paragraph (2), no mascot, emblem or other ornamental object shall be carried by a motor vehicle first used on or after 1st October 1937 in any position where it is likely to strike any person with whom the vehicle may collide unless the mascot is not liable to cause injury to such person by reason of any projection thereon.

(2) Instead of complying with the requirements of paragraph (1) a vehicle may comply with Community Directive 74/483 or 79/488 or ECE Regulation 26.01.

#### Commencement Information

**I47** Reg. 53 in force at 11.8.1986, see **reg. 1**

### [<sup>F360</sup>Strength of superstructure

**53A.**—(1) This regulation applies to every coach which is—

- (a) a single decked vehicle;
- (b) equipped with a compartment below the deck for the luggage of passengers; and
- (c) first used on or after [<sup>F361</sup>1st April 1993].

(2) Every vehicle to which this regulation applies shall comply with the requirements of ECE Regulation 66.

#### Textual Amendments

**F360** Regs. 53A, 53B inserted (31.7.1987) by The Road Vehicles (Construction and Use) (Amendment) (No.2) Regulations 1987 (S.I. 1987/1133), regs. 1, 4

**F361** Words in reg. 53A(1)(c) substituted (11.1.1990) by The Road Vehicles (Construction and Use) (Amendment) (No. 4) Regulations 1989 (S.I. 1989/2360), regs. 1, 3

### Additional exits from double-decked coaches

**53B.**—(1) This regulation applies to every coach which is—



**Status:** This revised version has been created from an electronic version contributed by Westlaw which was originally derived from the printed publication. **Read more** (See end of Document for details)**Changes to legislation:** There are currently no known outstanding effects for the The Road Vehicles (Construction and Use) Regulations 1986. (See end of Document for details)

- (a) a double-decked vehicle; and
- (b) first used on or after 1st April 1990.

(2) Subject to the following provisions of this regulation, every vehicle to which this regulation applies shall be equipped with two staircases, one of which shall be located in one half of the vehicle and the other in the other half of the vehicle.

(3) Instead of being equipped with two staircases in accordance with paragraph (2), a vehicle to which this regulation applies may be equipped in accordance with the following provisions of this regulation with a hammer or other similar device with which in case of emergency any side window of the vehicle may be broken.

(4) Where a vehicle is equipped with—

- (a) a staircase located in one half of the vehicle; and
- (b) an emergency exit complying with regulation 21(8) of the Public Service Vehicles (Conditions of Fitness, Equipment, Use and Certification) Regulations 1981 located in the same half of the upper deck of the vehicle;

the hammer or the similar device shall be located in the other half of that deck.

(5) Any hammer or other similar device with which a vehicle is equipped pursuant to this regulation shall be located in a conspicuous and readily accessible position in the upper deck of the vehicle.

(6) There shall be displayed, in a conspicuous position in close proximity to the hammer or other similar device, a notice which shall contain in clear and indelible lettering—

- (a) in letters not less than 25 mm high, the heading “IN EMERGENCY”; and
- (b) in letters not less than 10 mm high, instructions that in case of emergency the hammer or device is to be used first to break any side window by striking the glass near the edge of the window and then to clear any remaining glass from the window aperture.

(7) For the purposes of this regulation a staircase, emergency exit, hammer or other similar device (as the case may be) shall be considered to be located in the other half of the vehicle if the shortest distance between any part of that staircase, exit, hammer or device (as the case may be) and any part of any other staircase, emergency exit, hammer or device is not less than one half of the overall length of the vehicle.]

#### Textual Amendments

**F360** Regs. 53A, 53B inserted (31.7.1987) by [The Road Vehicles \(Construction and Use\) \(Amendment\) \(No.2\) Regulations 1987 \(S.I. 1987/1133\)](#), regs. 1, 4

#### [<sup>F362</sup> Alternative means of compliance

**53C.**—[

<sup>F363</sup>(1)] A coach which is required by either regulation 53A or 53B, as the case may be, to meet the requirements specified in that particular provision, need not meet them if it meets the requirements of such of the Annexes to Directive 2001/85/EC of the European Parliament and of the Council of 20 November 2001, relating to special provisions for vehicles used for the carriage of passengers comprising more than eight seats in addition to the driver’s seat, and amending Directives 70/156/EEC and 97/27/EC, as apply to that coach..

[

**Status:** Point in time view as at 31/03/2009.

**Status:** This revised version has been created from an electronic version contributed by Westlaw which was originally derived from the printed publication. **Read more** (See end of Document for details)**Changes to legislation:** There are currently no known outstanding effects for the The Road Vehicles (Construction and Use) Regulations 1986. (See end of Document for details)

<sup>F364</sup>(2) A coach which is required by either regulation 53A or 53B, as the case may be, to meet the requirements specified in that particular provision, need not meet them if it meets such requirements of ECE Regulation 107.01 or 107.02 as apply to that coach.]]

#### Textual Amendments

- F362** Reg. 53C added (12.12.2005) by The Road Vehicles (Construction and Use) (Amendment) (No.3) Regulations 2005 (S.I. 2005/2987), regs. 1, 4
- F363** Reg. 53C renumbered as reg. 53C(1) (3.3.2009) by The Road Vehicles (Construction and Use) (Amendment) Regulations 2009 (S.I. 2009/142), regs. 1(2), **7(2)(a)**
- F364** Reg. 53C(2) added (3.3.2009) by The Road Vehicles (Construction and Use) (Amendment) Regulations 2009 (S.I. 2009/142), regs. 1(2), **7(2)(b)**

## K

### CONTROL OF EMISSIONS

#### <sup>F365</sup>Silencers-general]

54.—(1) Every vehicle propelled by an internal combustion engine shall be fitted with an exhaust system including a silencer and the exhaust gases from the engine shall not escape into the atmosphere without first passing through the silencer.

(2) Every exhaust system and silencer shall be maintained in good and efficient working order and <sup>F366</sup>shall not after the date of manufacture be altered] so as to increase the noise made by the escape of exhaust gases.

(3) Instead of complying with paragraph (1) a vehicle may comply with Community Directive 77/212, 81/334, 84/372 <sup>F367</sup>, 84/424 or 92/97 or ECE Regulation 51.02] or, in the case of a motor cycle other than a moped, 78/1015 <sup>F368</sup>, 87/56 or 89/235.]

(4) In this regulation “moped” has the meaning given to it in paragraph (5) of Schedule 9.

#### Textual Amendments

- F365** Reg. 54 heading substituted (1.7.1994) by The Road Vehicles (Construction and Use) (Amendment) Regulations 1994 (S.I. 1994/14), regs. 1(1), **3(2)**
- F366** Words in reg. 54(2) substituted (1.7.1994) by The Road Vehicles (Construction and Use) (Amendment) Regulations 1994 (S.I. 1994/14), regs. 1(1), **3(3)**
- F367** Words in reg. 54(3) substituted (1.10.1996) by The Road Vehicles (Construction and Use) (Amendment) (No. 5) Regulations 1996 (S.I. 1996/2329), regs. 1, **4(2)(a)**
- F368** Words in reg. 54(3) inserted (1.10.1996) by The Road Vehicles (Construction and Use) (Amendment) (No. 5) Regulations 1996 (S.I. 1996/2329), regs. 1, **4(2)(b)**

#### Commencement Information

- I48** Reg. 54 in force at 11.8.1986, see **reg. 1**

#### <sup>F369</sup>Noise limits—certain vehicles with 3 or more wheels—general]

55.—(1) Save as provided in <sup>F370</sup>paragraphs (1A) and (2)] and regulation 59, this regulation applies to every wheeled motor vehicle having at least three wheels and first used on or after 1st October 1983 which is—

- (a) a vehicle, not falling within sub-paragraph (b) or (c), with or without bodywork;

- (b) a vehicle not falling within sub-paragraph (c) which is—
  - (i) engineering plant;
  - (ii) a locomotive other than an agricultural motor vehicle;
  - (iii) a motor tractor other than an industrial tractor or an agricultural motor vehicle;
  - (iv) a public works vehicle;
  - (v) a works truck; or
  - (vi) a refuse vehicle; or
- (c) a vehicle which—
  - (i) has a compression ignition engine;
  - (ii) is so constructed or adapted that the driving power of the engine is, or by appropriate use of the controls can be, transmitted to all wheels of the vehicle; and
  - (iii) falls within category I.1.1., I.1.2, or I.1.3 specified in Article 1 of Community Directive 77/212.

[<sup>F371</sup>(1A) This regulation does not apply to a vehicle to which an item in the Table in regulation 55A applies.]

- (2) This regulation does not apply to—
  - (a) a motorcycle with a sidecar attached;
  - (b) an agricultural motor vehicle which is first used before 1st June 1986 or which is not driven at more than 20 mph;
  - (c) an industrial tractor;
  - (d) a road roller;
  - (e) a vehicle specially constructed, and not merely adapted, for the purposes of fighting fires or salvage from fires at or in the vicinity of airports, and having an engine power exceeding 220 kW;
  - (f) a vehicle which runs on rails; or
  - (g) a vehicle manufactured by Leyland Vehicles Ltd. and known as the Atlantean Bus, if first used before 1st October 1984.

(3) Save as provided in paragraphs (4) and (5), every vehicle to which this regulation applies shall be so constructed that it complies with the requirements set out in item 1, 2, 3 or 4 of the Table; a vehicle complies with those requirements if—

- (a) its sound level does not exceed the relevant limit specified in column 2(a), (b) or (c), as the case may be, in the relevant item when measured under the conditions specified in column 3 in that item and by the method specified in column 4 in that item using the apparatus prescribed in paragraph (6); and
- (b) in the case of a vehicle referred to in paragraph 1(a) (other than one having less than four wheels or a maximum speed not exceeding 25 km/h) or 1(c), the device designed to reduce the exhaust noise meets the requirements specified in column 5 in that item.

## TABLE

(regulation 55(3))

**Status:** Point in time view as at 31/03/2009.

**Status:** This revised version has been created from an electronic version contributed by Westlaw which was originally derived from the printed publication. **Read more** (See end of Document for details)**Changes to legislation:** There are currently no known outstanding effects for the The Road Vehicles (Construction and Use) Regulations 1986. (See end of Document for details)

1	2			3	4	5
Item	<i>Limits of sound level</i>			<i>Conditions of measurement</i>	<i>Method of measurement</i>	<i>Requirements for exhaust device</i>
	<i>(a)</i> <i>Vehicle referred to in paragraph (a)</i>	<i>(b)</i> <i>Vehicle referred to in paragraph (b)</i>	<i>(c)</i> <i>Vehicle referred to in paragraph (c)</i>			
1	Limits specified in paragraph I.1 of the Annex to Community Directive 77/212.	89dB(A)	82dB(A)	Conditions specified in paragraph I.3 of the Annex to Community Directive 77/212	Method specified in paragraph I.4.1 of the Annex to Community Directive 77/212	Requirements specified in heading II of the Annex to Community Directive 77/212 (except paragraphs II.2 and II.5).
2	Limits specified in paragraph 5.2.2.1 of Annex I to Community Directive 81/334.	89dB(A)	82dB(A)	Conditions specified in paragraph 5.2.2.3 of Annex I to Community Directive 81/334.	Method specified in paragraph 5.2.2.4 of Annex I to Community Directive 81/334. Interpretation of results as specified in paragraph 5.2.2.5 of that Annex.	Requirements specified in section 3 and paragraphs 5.1 and 5.3.1 of Annex 1 to Community Directive 81/334.
3	Limits specified in paragraph 5.2.2.1 of Annex I to Community Directive 84/372	89dB(A)	82dB(A)	Conditions specified in paragraph 5.2.2.3 of Annex I to Community Directive 84/372	Method specified in paragraph 5.2.2.4 of Annex I to Community Directive 84/372, except that vehicles with 5 or more forward gears and a maximum power to maximum gross weight ratio not less than 75 kW per 1000 kg may be tested in	Requirements specified in section 3 and paragraphs 5.1 and 5.3.1 of Annex I to Community Directive 84/372.

Status: This revised version has been created from an electronic version contributed by Westlaw which was originally derived from the printed publication. **Read more** (See end of Document for details) **Changes to legislation:** There are currently no known outstanding effects for the The Road Vehicles (Construction and Use) Regulations 1986. (See end of Document for details)

1	2			3	4	5
Item	(a)	(b)	(c)	Conditions of measurement	Method of measurement	Requirements for exhaust device
	<i>Limits of sound level</i>					
	Vehicle referred to in paragraph (a)	Vehicle referred to in paragraph (b)	Vehicle referred to in paragraph (c)			
4	Limits specified in paragraph 5.2.2.1 of the Annex I to Community Directive 84/424	Vehicles with engine power— –less than 75kW  – 84dB(A)  –not less than 75kW  –86dB(A)	Limits specified in paragraph 5.2.2.1 of Annex I to Community Directive 84/424.	Conditions specified in paragraph 5.2.2.3 of Annex I to Community Directive 84/424	Method specified in paragraph 5.2.2.4 of Annex I to Community Directive 84/424, except that vehicles with 5 or more forward gears and a maximum power to maximum gross weight ratio not less than 75 kW per 1000 kg may be tested in 3rd gear only. Interpretation of results as specified in paragraph 5.2.2.5 of that Annex.	Requirements specified in section 3 and paragraphs 5.1 and 5.3.1 of Annex I to Community Directive 84/424.

(4) Save as provided in paragraph (5), paragraph (3) applies to every vehicle to which this regulation applies and which is first used on or after 1st April 1990, unless it is equipped with 5 or more forward gears and has a maximum power to maximum gross weight ratio not less than 75 kW per 1000 kg, and is of a type in respect of which a type approval certificate has been issued under the Type Approval (Great Britain) Regulations as if, for the reference to items 1, 2, 3 or 4 of the Table there were substituted a reference to item 4 of the Table.

(5) Paragraph (4) does not apply to a vehicle in category 5.2.2.1.3 as defined in Annex I to Directive 84/424 and equipped with a compression ignition engine, a vehicle in category 5.2.2.1.4

**Status:** Point in time view as at 31/03/2009.

**Status:** This revised version has been created from an electronic version contributed by Westlaw which was originally derived from the printed publication. **Read more** (See end of Document for details)**Changes to legislation:** There are currently no known outstanding effects for the The Road Vehicles (Construction and Use) Regulations 1986. (See end of Document for details)

as defined in that Annex, or a vehicle referred to in paragraph 1(b) unless it is first used on or after 1st April 1991.

(6) The apparatus prescribed for the purposes of paragraph 3(a) and [<sup>F372</sup>regulation 56(2)(a) and Schedule 7A] is a sound level meter of the type described in Publication No. 179 of the International Electrotechnical Commission, in either its first or second edition, a sound level meter complying with the specification for Type 0 or Type 1 in Publication No. 651 (1979) “Sound Level Meters” of the International Electrotechnical Commission, or a sound level meter complying with the specifications of the British Standard Number BS 5969:1981 which came into effect on 29th May 1981.

[<sup>F373</sup>(6A) A vehicle shall be deemed to satisfy the requirements of this regulation if it is so constructed that it complies with the requirements specified in column 4 of item 2 in the Table in regulation 55A as they apply to a vehicle first used on or after the date specified in column 3 of that item.]

(7) Instead of complying with the preceding provisions of this regulation a vehicle may comply at the time of its first use with Community Directive 77/212, 81/334, 84/372 [<sup>F374</sup>, 84/424, 92/97 or 96/20 or ECE Regulation 51.02].

#### Textual Amendments

- F369** Reg. 55 heading substituted (1.10.1996) by [The Road Vehicles \(Construction and Use\) \(Amendment\) \(No. 5\) Regulations 1996 \(S.I. 1996/2329\)](#), regs. 1, **5(2)**
- F370** Words in reg. 55(1) substituted (1.10.1996) by [The Road Vehicles \(Construction and Use\) \(Amendment\) \(No. 5\) Regulations 1996 \(S.I. 1996/2329\)](#), regs. 1, **5(3)**
- F371** Reg. 55(1A) inserted (1.10.1996) by [The Road Vehicles \(Construction and Use\) \(Amendment\) \(No. 5\) Regulations 1996 \(S.I. 1996/2329\)](#), regs. 1, **5(4)**
- F372** Words in reg. 55(6) substituted (1.7.1994) by [The Road Vehicles \(Construction and Use\) \(Amendment\) Regulations 1994 \(S.I. 1994/14\)](#), regs. 1(1), **3(4)**
- F373** Reg. 55(6A) inserted (1.10.1996) by [The Road Vehicles \(Construction and Use\) \(Amendment\) \(No. 5\) Regulations 1996 \(S.I. 1996/2329\)](#), regs. 1, **5(5)**
- F374** Words in reg. 55(7) substituted (1.10.1996) by [The Road Vehicles \(Construction and Use\) \(Amendment\) \(No. 5\) Regulations 1996 \(S.I. 1996/2329\)](#), regs. 1, **5(6)**

#### Commencement Information

- I49** Reg. 55 in force at 11.8.1986, see [reg. 1](#)

#### [<sup>F375</sup>Noise limits—certain vehicles first used on or after 1st October 1996—general

**55A.**—(1) A motor vehicle to which an item in the Table below applies shall be so constructed that it meets the requirements specified in column 4 of that item; and an item in that Table applies to a vehicle if it is of the description specified in column 2 of that item.

This paragraph has effect subject to the following provisions of this regulation, regulation 59 and Schedule 7XA.

**Status:** This revised version has been created from an electronic version contributed by Westlaw which was originally derived from the printed publication. **Read more** (See end of Document for details) **Changes to legislation:** There are currently no known outstanding effects for the The Road Vehicles (Construction and Use) Regulations 1986. (See end of Document for details)

## THE TABLE

(1) <i>Item</i>	(2) <i>Vehicles to which the item applies</i>	(3) <i>Earliest date of first use (see column 2)</i>	(4) <i>The requirements</i>	(5) <i>Modification of Community Directives in relation to special vehicles (See paragraph (4) (c))</i>
1	<p>1. All motor vehicles with less than 4 wheels and first used on or after the date specified in column 3 of this item.</p> <p>2. All special vehicles first used on or after the date specified in column 3 of this item.</p> <p>3. All motor vehicles first used on or after the date specified in column 3 of this item with a maximum speed not exceeding 25 km/h.</p>	1st October 1996	<p>The requirements of—</p> <p>(a) regulation 55 as they would apply to the vehicle but for paragraph (1A) of that regulation; or</p> <p>(b) paragraphs 3 and 5.2 of Annex I to Community Directive 92/97 or 96/20.</p>	<p>For paragraph 5.2.2.1 of Annex I, substitute—</p> <p>“The sound level measured in accordance with 5.2.2.2 to 5.2.2.5 of this Annex shall not exceed—</p> <p>(a) in the case of vehicles with engine power of less than 75 kW, 84 dB(A)</p> <p>(b) in the case of vehicles with engine power not less than 75 kW, 86 dB(A).”</p>
2	All motor vehicles first used on or after the date specified in column 3 of this item, not being a vehicle to which item 1 applies.	1st October 1996	The requirements of paragraphs 3 and 5 of Annex I to Community Directive 92/97 or 96/20.	

(2) Paragraph (1) does not apply to—

- (a) a vehicle with fewer than 3 wheels; or
- (b) a vehicle of a description mentioned in regulation 55(2).

(3) In this regulation, “special vehicle” means a vehicle which is—

- (a) engineering plant;
- (b) a locomotive other than an agricultural motor vehicle;

**Status:** Point in time view as at 31/03/2009.

**Status:** This revised version has been created from an electronic version contributed by Westlaw which was originally derived from the printed publication. **Read more** (See end of Document for details)**Changes to legislation:** There are currently no known outstanding effects for the The Road Vehicles (Construction and Use) Regulations 1986. (See end of Document for details)

- (c) a motor tractor other than an industrial tractor or an agricultural motor vehicle;
  - (d) a public works vehicle; or
  - (e) a works truck.
- (4) For the purposes of this regulation—
- (a) subject to paragraphs (b), (c), (d) and (e), the Community Directives referred to in this regulation shall have effect in relation to a vehicle that is not a “vehicle” within the meaning of the Framework Directive but is of a class of a description specified in column 2 of an item in the Table in regulation 15 (whether or not regulation 15 applies to the vehicle) as it has effect in relation to a vehicle of the category specified in column 3 of that item;
  - (b) subject to paragraphs (c), (d) and (e), a vehicle that does not fall within sub-paragraph (a) and is not a “vehicle” within the meaning of the Framework Directive shall be regarded as meeting the requirements of paragraph 5 of a Community Directive mentioned in the Table if it meets—
    - (i) the requirements of that paragraph as it applies to a vehicle in category M<sub>1</sub> or N<sub>1</sub> within the meaning of the Community Directive, or
    - (ii) the requirements of that paragraph as it applies to a vehicle that is not in either of those categories;
  - (c) subject to sub-paragraphs (d) and (e), in relation to a special vehicle the Community Directives mentioned in column 4 of an item in the Table shall have effect with the modifications (if any) specified in column 5 of the item;
  - (d) a requirement in paragraph 5.2.2.1 of Annex 1 to Community Directive 92/97 for a sound level not to exceed a specified limit in specified circumstances shall be read as a requirement for the sound level not to exceed that limit by more than the amount mentioned in paragraph 4.1 of Annex V to the Community Directive in those circumstances;
  - (e) a requirement in paragraph 5.2.2.1 of Annex 1 to Community Directive 96/20 for a sound level not to exceed a specified limit in specified circumstances shall be read as a requirement for the sound level not to exceed that limit by more than the amount mentioned in paragraph 4.1 of Annex III to the Directive in those circumstances.
- (5) Instead of complying with paragraph (1) a vehicle may comply at the time of its first use—
- (a) in the case of a vehicle to which item 1 of the Table applies, with Community Directive 77/212, 81/334, 84/424, 92/97 or 96/20 or ECE Regulation 51.02; or
  - (b) in the case of a vehicle to which item 2 of the Table applies, with Community Directive 92/97 or 96/20 or ECE Regulation 51.02.]

#### Textual Amendments

**F375** Reg. 55A inserted (1.10.1996) by [The Road Vehicles \(Construction and Use\) \(Amendment\) \(No. 5\) Regulations 1996 \(S.I. 1996/2329\)](#), regs. 1, 6

#### Noise limits—agricultural motor vehicles and industrial tractors

**56.**—(1) Save as provided in regulation 59, this regulation applies to every wheeled vehicle first used on or after 1st April 1983 being an agricultural motor vehicle or an industrial tractor, other than—

- (a) an agricultural motor vehicle which is first used on or after 1st June 1986 and which is driven at more than 20 mph; or
- (b) a road roller.



**Status:** This revised version has been created from an electronic version contributed by Westlaw which was originally derived from the printed publication. **Read more** (See end of Document for details)**Changes to legislation:** There are currently no known outstanding effects for the The Road Vehicles (Construction and Use) Regulations 1986. (See end of Document for details)

- (2) Every vehicle to which this regulation applies shall be so constructed—
- (a) that its sound level does not exceed—
- (i) if it is a vehicle with engine power of less than 65kW, 89 dB(A);
  - (ii) if it is a vehicle with engine power of 65kW or more, and first used before 1st October 1991, 92 dB(A); or
  - (iii) if it is a vehicle with engine power of 65kW or more, and first used on or after 1st October 1991, 89 dB(A),
- when measured under the conditions specified in paragraph I.3 of Annex VI of Community Directive 74/151 by the method specified in paragraph I.4.1 of that Annex using the apparatus prescribed in regulation 55(6); and
- (b) that the device designed to reduce the exhaust noise meets the requirements specified in paragraph II.1 of that Annex and, if fibrous absorbent material is used, the requirements specified in paragraphs II.4.1 to II.4.3 of that Annex.

**Commencement Information**

**I50** Reg. 56 in force at 11.8.1986, see [reg. 1](#)

**[<sup>F376</sup>Noise limits construction requirements relating to motor cycles**

**57.**—(1) Subject to regulation 59, this regulation applies to every motor vehicle first used on or after 1st April 1983 which is—

- (a) a moped; or
  - (b) a two-wheeled motor cycle, whether or not with sidecar attached, which is not a moped.
- (2) A vehicle to which this regulation applies shall be so constructed that it meets,—
- (a) if it is first used before 1st April 1991, the requirements of item 1 or 2 of the Table in Part I of Schedule 7A;
  - (b) if it is first used on or after that date, the requirements of item 2 of that Table.
- (3) Instead of complying with paragraph (2), a vehicle first used before 1st April 1991 may comply at the time of its first use with Community Directive 78/1015, 87/56 or 89/235.
- (4) Instead of complying with paragraph (2), a vehicle first used on or after 1st April 1991 may comply at the time of its first use with Community Directive 87/56 or 89/235.
- (5) In this regulation “moped” has the meaning given to it in paragraph 5 of Schedule 9.]

**Textual Amendments**

**F376** Regs. 57-57B substituted for reg. 57 (1.7.1994) by [The Road Vehicles \(Construction and Use\) \(Amendment\) Regulations 1994 \(S.I. 1994/14\)](#), regs. 1(1), 3(5), [Sch. 1](#)

**Commencement Information**

**I51** Reg. 57 in force at 11.8.1986, see [reg. 1](#)

**[<sup>F376</sup>Exhaust systems motor cycles**

**57A.**—(1) Any original silencer forming part of the exhaust system of a vehicle to which regulation 57 applies, being a vehicle first used before 1st February 1996, shall—

**Status:** Point in time view as at 31/03/2009.

**Status:** This revised version has been created from an electronic version contributed by Westlaw which was originally derived from the printed publication. **Read more** (See end of Document for details)**Changes to legislation:** There are currently no known outstanding effects for the The Road Vehicles (Construction and Use) Regulations 1986. (See end of Document for details)

- (a) be so constructed that the vehicle meets the requirements specified in paragraph 3 (other than sub-paragraphs 3.2 and 3.3) of Annex I to Community Directive 78/1015 and be marked in accordance with sub-paragraph 3.3 of that Annex; or
  - (b) be so constructed that the vehicle meets the requirements specified in paragraph 3 (other than sub-paragraphs 3.2 and 3.3) of Annex I to Community Directive 89/235 and be marked in accordance with sub-paragraph 3.3 of that Annex.
- (2) Any original silencer forming part of the exhaust system of a vehicle to which regulation 57 applies, being a vehicle first used on or after 1st February 1996, shall be so constructed that the vehicle meets the requirements specified in paragraph 3 (other than sub-paragraphs 3.2 and 3.3) of Annex I to Community Directive 89/235 and be marked in accordance with sub-paragraph 3.3 of that Annex.
- (3) A vehicle fitted with an original silencer may,—
- (a) if the vehicle is first used before 1st February 1996, instead of complying with paragraph (1), comply at the time of first use with Community Directive 78/1015, 87/56 or 89/235; or
  - (b) if the vehicle is first used on or after that date, instead of complying with paragraph (2), comply at the time of first use with Community Directive 89/235.
- (4) Where any replacement silencer forms part of the exhaust system of a vehicle to which regulation 57 applies, being a vehicle first used on or after 1st January 1985, the first requirement or the second requirement as set out below must be met in respect of the silencer.
- (5) In order for the first requirement to be met in respect of a silencer forming part of the exhaust system of a vehicle (in this paragraph referred to as “the vehicle in question”),—
- (a) if the vehicle in question is first used before 1st April 1991, the silencer must be so constructed that, were it to be fitted to an unused vehicle of the same model as the vehicle in question, the unused vehicle would meet—
    - (i) the requirements of item 1 or 3 of the Table in Part I of Schedule 7A; and
    - (ii) the requirements specified in paragraph 3 (other than sub-paragraphs 3.2 and 3.3) of Annex I to Community Directive 78/1015 or 89/235,
 and the silencer must be marked in accordance with sub-paragraph 3.3 of Annex I to Community Directive 78/1015 or 89/235;
  - (b) if the vehicle in question is first used on or after the 1st April 1991 but before 1st February 1996, the silencer must be so constructed that, were it to be fitted to an unused vehicle of the same model as the vehicle in question, the unused vehicle would meet—
    - (i) the requirements of item 3 of the Table in Part I of Schedule 7A; and
    - (ii) the requirements specified in paragraph 3 (other than sub-paragraphs 3.2 and 3.3) of Annex I to Community Directive 78/1015 or 89/235,
 and the silencer must be marked in accordance with sub-paragraph 3.3 of Annex I to Community Directive 78/1015 or 89/235;
  - (c) if the vehicle in question is first used on or after 1st February 1996, the silencer must be so constructed that, were it to be fitted to an unused vehicle of the same model as the vehicle in question, the unused vehicle would meet—
    - (i) the requirements of item 3 of the Table in Part I of Schedule 7A; and
    - (ii) the requirements specified in paragraph 3 (other than sub-paragraphs 3.2 and 3.3) of Annex I to Community Directive 89/235,
 and the silencer must be marked in accordance with sub-paragraph 3.3 of Annex I to that Directive.

(6) In order for the second requirement to be met in respect of a silencer forming part of the exhaust system of a vehicle (in Part II of Schedule 7A referred to as “the vehicle in question”),—

- (a) if the vehicle is first used before 1st April 1991, the silencer must meet the requirements of paragraph 2, 3 or 4 of Part II of Schedule 7A; or
- (b) if the vehicle is first used on or after that date, the silencer must meet the requirements of paragraph 4 of Part II of Schedule 7A.

(7) Any requirements specified in paragraph (5) or in Part II of Schedule 7A relating to the silencer were it to be fitted to an unused vehicle of the same model as the vehicle in question (as defined in that paragraph or in paragraph (6) for the purposes of that Part, as the case may be) shall be deemed to be met if they are met by the silencer as fitted to the vehicle in question at the time that it is first fitted.

(8) For the purposes of this regulation, Community Directive 89/235 shall have effect as if—

- (a) in Annex I, for sub-paragraph 3.4.1, there were substituted—
  - “(3.4.1) After removal of the fibrous material, the vehicle must meet the relevant requirements.”; and
  - for sub-paragraph 3.4.3 there were substituted—
    - “(3.4.3) After the exhaust system has been put into a normal state for road use by one of the following conditioning methods, the vehicle must meet the relevant requirements.”;
- (b) references in Annex I as so modified to a vehicle meeting the relevant requirements were,
  - 
  - (i) in relation to an original silencer, references to a vehicle meeting the requirements of item 2 of the Table in Part I of Schedule 7A; and
  - (ii) in relation to a replacement silencer, references to a vehicle meeting the requirements of item 3 of that Table;
- (c) in Annex II there were omitted sub-paragraphs 3.1.2, 3.4 and 3.5 and in sub-paragraph 3.2—
  - (i) the words “and the name referred to in 3.1.2”, and
  - (ii) the words after “legible”.

I  
F377(8A) For the purposes of paragraphs (1)(b) and (2) in their application to vehicles with a design speed not exceeding 50km/h, Community Directive 89/235/EEC shall have effect as if it were not only modified in accordance with paragraph (8) but were further modified by the omission of—

- (a) sub-paragraph 3.1.3 of Annex II; and
- (b) in sub-paragraph 3.2 of that Annex, the words “and 3.1.3”.]

(9) In relation to a replacement silencer which is—

- (a) fitted to a vehicle before 1st February 1997; and
- (b) clearly and indelibly marked with the name or trade mark of the manufacturer of the silencer and with that manufacturer’s part number relating to it,

paragraphs (5) and (6) of this regulation and Parts II and III of Schedule 7A shall have effect as if they contained no reference to a silencer being marked.

(10) For the purposes of this regulation, a silencer forming part of the exhaust system of a vehicle shall not be regarded as being marked in accordance with sub-paragraph 3.3 of Annex I to Community Directive 78/1015 or 89/235, paragraph (9) of this regulation or any paragraph of Part II of Schedule 7A if the marking is so obscured by any part of the vehicle that it cannot easily be read.

**Status:** Point in time view as at 31/03/2009.

**Status:** This revised version has been created from an electronic version contributed by Westlaw which was originally derived from the printed publication. **Read more** (See end of Document for details)**Changes to legislation:** There are currently no known outstanding effects for the The Road Vehicles (Construction and Use) Regulations 1986. (See end of Document for details)

(11) Until 1st February 1996, for the purposes of paragraph (6), a vehicle first used on or after 1st April 1991 shall be treated as a vehicle first used before 1st April 1991.

(12) Part III of Schedule 7A shall have effect for the purpose of exempting certain silencers from the provisions of paragraph (4).

(13) No person shall use a motor cycle on a road or cause or permit such a vehicle to be so used if any part of the exhaust system has been indelibly marked by the manufacturer of that part with the words “NOT FOR ROAD USE” or words to that effect.

(14) In this regulation—

“original silencer”, in relation to a vehicle, means a silencer which was fitted to the vehicle when it was manufactured;

“replacement silencer”, in relation to a vehicle, means a silencer fitted to the vehicle, not being an original silencer; and

“trade mark” has the same meaning as in the Trade Marks Act 1938.]

#### Textual Amendments

**F376** Regs. 57-57B substituted for reg. 57 (1.7.1994) by [The Road Vehicles \(Construction and Use\) \(Amendment\) Regulations 1994 \(S.I. 1994/14\)](#), regs. 1(1), 3(5), [Sch. 1](#)

**F377** Reg. 57A(8A) inserted (1.2.1996) by [The Road Vehicles \(Construction and Use\) \(Amendment\) Regulations 1996 \(S.I. 1996/16\)](#), regs. 1, [2\(2\)](#)

#### [<sup>F376</sup> **Noise limits maintenance requirements relating to motor cycles**

**57B.**—(1) No person shall use or cause or permit to be used on a road a motor cycle to which regulation 57 applies if the three conditions specified below are all fulfilled.

(2) The first condition is fulfilled if the vehicle does not meet the noise limit requirements.

(3) The second condition is fulfilled if—

- (a) any part of the vehicle is not in good and efficient working order, or
- (b) the vehicle has been altered.

(4) The third condition is fulfilled if the noise made by the vehicle would have been materially less (so far as applicable)—

- (a) were all parts of the vehicle in good and efficient working order, or
- (b) had the vehicle not been altered.

(5) For the purposes of this regulation, a vehicle meets the noise limit requirements if,—

- (a) in the case of a vehicle first used before 1st April 1991 and not fitted with a replacement silencer, it meets the requirements of item 1 or 2 of the Table in Part I of Schedule 7A;
- (b) in the case of a vehicle first used before 1st April 1991 and fitted with a replacement silencer, it meets the requirements of item 1 or 3 of that Table;
- (c) in the case of a vehicle first used on or after 1st April 1991 and not fitted with a replacement silencer, it meets the requirements of item 2 of that Table;
- (d) in the case of a vehicle first used on or after 1st April 1991 and fitted with a replacement silencer, it meets the requirements of item 3 of that Table.

(6) In this regulation, “replacement silencer” has the same meaning as in regulation 57A.]

**Status:** This revised version has been created from an electronic version contributed by Westlaw which was originally derived from the printed publication. **Read more** (See end of Document for details)**Changes to legislation:** There are currently no known outstanding effects for the The Road Vehicles (Construction and Use) Regulations 1986. (See end of Document for details)

**Textual Amendments**

**F376** Regs. 57-57B substituted for reg. 57 (1.7.1994) by [The Road Vehicles \(Construction and Use\) \(Amendment\) Regulations 1994 \(S.I. 1994/14\)](#), regs. 1(1), 3(5), **Sch. 1**

**Noise limits—vehicles not subject to regulations 55 to 57, first used on or after 1st April 1970**

<sup>F378</sup>**58.** . . . . .

**Textual Amendments**

**F378** Reg. 58 omitted (1.6.1995) by virtue of [The Road Vehicles \(Construction and Use\) \(Amendment\) \(No. 3\) Regulations 1995 \(S.I. 1995/1201\)](#), regs. 1, 4

**[<sup>F379</sup>Exceptions to regulations 55 to 57B]**

**59.** Regulations 55, [<sup>F380</sup>55A,] 56, [<sup>F381</sup>57,][<sup>F382</sup>57A and 57B] do not apply to a motor vehicle which is—

- (a) proceeding to a place where, by previous arrangement—
  - (i) noise emitted by it is about to be measured for the purpose of ascertaining whether or not the vehicle complies with such of those provisions as apply to it; or
  - (ii) the vehicle is about to be mechanically adjusted, modified or equipped for the purpose of securing that it so complies; or
- (b) returning from such a place immediately after the noise has been so measured.

**Textual Amendments**

**F379** Reg. 59 heading substituted (1.6.1995) by [The Road Vehicles \(Construction and Use\) \(Amendment\) \(No. 3\) Regulations 1995 \(S.I. 1995/1201\)](#), regs. 1, **5(2)**

**F380** Word in reg. 59 inserted (1.10.1996) by [The Road Vehicles \(Construction and Use\) \(Amendment\) \(No. 5\) Regulations 1996 \(S.I. 1996/2329\)](#), regs. 1, 7

**F381** Words in reg. 59 substituted (1.7.1994) by [The Road Vehicles \(Construction and Use\) \(Amendment\) Regulations 1994 \(S.I. 1994/14\)](#), regs. 1(1), **3(7)**

**F382** Words in reg. 59 substituted (1.6.1995) by [The Road Vehicles \(Construction and Use\) \(Amendment\) \(No. 3\) Regulations 1995 \(S.I. 1995/1201\)](#), regs. 1, **5(3)**

**Commencement Information**

**I52** [Reg. 59](#) in force at 11.8.1986, see [reg. 1](#)

**Radio interference suppression**

**60.**—[<sup>F383</sup>(1) Subject to paragraphs (1B), (1D), (1E) and (2)—

- (a) every vehicle to which this sub-paragraph applies shall be so constructed that it complies with the requirements of paragraph 6 of Annex 1 to Community Directive 72/245 or paragraph 6 (as read with paragraph 8) of Annex 1 to Community Directive 95/54 (whether or not those Community Directives apply to the vehicle); and

**Status:** Point in time view as at 31/03/2009.

**Status:** This revised version has been created from an electronic version contributed by Westlaw which was originally derived from the printed publication. **Read more** (See end of Document for details)**Changes to legislation:** There are currently no known outstanding effects for the The Road Vehicles (Construction and Use) Regulations 1986. (See end of Document for details)

- (b) every agricultural and forestry tractor which is propelled by a spark ignition engine and is first used on or after 1st April 1974 shall be so constructed that it meets the requirements of paragraph 6 of Community Directive 72/245, 75/322 or 95/54.
- (1A) Paragraph (1)(a) applies to every wheeled vehicle which is propelled by a spark ignition engine and—
- (a) is first used on or after 1st April 1974 and before 1st January 1996; or
- (b) is first used on or after 1st January 1996 and is a “vehicle” within the meaning of the Framework Directive.
- (1B) For the purposes of paragraph (1)—
- (a) a requirement in paragraph 6.2.2 of Community Directive 72/245 or 75/322 for any description of radiation level not to exceed a specified limit when measured in specified circumstances shall be read as a requirement for that description of radiation level not to exceed that limit by more than the amount mentioned in paragraph 9.2 of those Community Directives when measured in those circumstances; and
- (b) a requirement in paragraph 6.2.2 or 6.3.2 of Community Directive 95/54 for any description of radiation level not to exceed a specified limit when measured in specified circumstances shall be read as a requirement for that description of radiation level not to exceed that limit by more than the amount mentioned in paragraph 7.3.1 of the Community Directive when measured in those circumstances.
- [<sup>F384</sup>(1C) Subject to paragraph (1F), the requirements of Community Directive 72/245/EC as amended by Community Directive 95/54/EC shall be met by electrical/electronic sub-assemblies as components or separate technical units first used on or after 1 October 2002.]
- (1D) Instead of complying with paragraph (1)(a) a vehicle may comply at the time of first use with Community Directive 72/245 or 95/54 or [<sup>F385</sup>ECE Regulations 10, 10.01 or 10.02].
- (1E) Instead of complying with paragraph (1)(b) a vehicle may comply at the time of first use with Community Directive 75/322.
- [<sup>F386</sup>(1F) The requirements of paragraph (1C) shall not apply to electrical/electronic sub-assemblies of the following descriptions—
- (a) replacement parts intended for use on vehicles manufactured in accordance with type approvals granted before 1 January 1996 in compliance with Community Directive 72/245/EEC or Community Directive 72/306/EEC including any subsequent extension that may have been granted to such type approvals;
- (b) electrical/electronic sub-assemblies fitted to any vehicle under an authorisation having effect under Part III of the Police Act 1997 or Part II of the Regulation of Investigatory Powers Act 2000.]]
- (2) This regulation does not apply to a vehicle constructed or assembled by a person not ordinarily engaged in the trade or business of manufacturing vehicles of that description, but nothing in this paragraph affects the application to such vehicles of the Wireless Telegraphy (Control of Interference from Ignition Apparatus) Regulations 1973.
- [<sup>F387</sup>(3) In this regulation “electrical/electronic sub-assembly” has the same meaning as in Community Directive 95/54.]

#### Textual Amendments

**F383** Reg. 60(1)-(1F) substituted for reg. 60(1) (1.10.1996) by [The Road Vehicles \(Construction and Use\) \(Amendment\) \(No. 5\) Regulations 1996](#) (S.I. 1996/2329), regs. 1, **8(2)**

**Status:** This revised version has been created from an electronic version contributed by Westlaw which was originally derived from the printed publication. **Read more** (See end of Document for details)**Changes to legislation:** There are currently no known outstanding effects for the The Road Vehicles (Construction and Use) Regulations 1986. (See end of Document for details)

- F384** Reg. 60(1C) substituted (4.9.2002) by [The Road Vehicles \(Construction and Use\) \(Amendment\) \(No. 3\) Regulations 2002 \(S.I. 2002/2126\)](#), regs. 1, **2(2)**
- F385** Words in reg. 60(1D) substituted (4.9.2002) by [The Road Vehicles \(Construction and Use\) \(Amendment\) \(No. 3\) Regulations 2002 \(S.I. 2002/2126\)](#), regs. 1, **2(3)**
- F386** Reg. 60(1F) substituted (4.9.2002) by [The Road Vehicles \(Construction and Use\) \(Amendment\) \(No. 3\) Regulations 2002 \(S.I. 2002/2126\)](#), regs. 1, **2(4)**
- F387** Reg. 60(3) inserted (1.10.1996) by [The Road Vehicles \(Construction and Use\) \(Amendment\) \(No. 5\) Regulations 1996 \(S.I. 1996/2329\)](#), regs. 1, **8(3)**

#### Commencement Information

- I53** Reg. 60 in force at 11.8.1986, see [reg. 1](#)

### Emission of smoke, vapour, gases, oily substances etc

**61.**—(1) Subject to <sup>F388</sup>paragraph (3B)], every vehicle shall be constructed <sup>F389</sup>and maintained] so as not to emit any avoidable smoke or avoidable visible vapour.

(2) Every motor vehicle using solid fuel shall be fitted with—

- (a) a tray or shield to prevent ashes and cinders from falling onto the road; and
- (b) an efficient appliance to prevent any emission of sparks or grit.

<sup>F390</sup>(2A) Paragraphs (3), (3A), (3C), (4A), (5)(b), (5)(c), (6), (7), (8), (9), (10) and (11) shall not apply to motor vehicles first used on or after 1st January 2001.]

(3) Subject to paragraph (4) and to the exemptions specified in an item in column 4 of <sup>F391</sup>Table I], every wheeled vehicle of a class specified in that item in column 2 shall be constructed so as to comply with the requirements specified in that item in column 3.

<sup>F392</sup>(3A) A motor vehicle to which an item in Table II applies shall be so constructed as to comply with the requirements relating to conformity of production models set out in the provisions specified in that item in column (4) of that Table.]

<sup>F393</sup>(3B) Instead of complying with paragraph (1) a vehicle may comply with a relevant instrument.

(3C) Instead of complying with such provisions of items 1, 2 and 3 in Table I as apply to it, a vehicle may at the time of its first use comply with a relevant instrument.]

(4) <sup>F394</sup>For the purposes of paragraphs (3B) and (3C), a reference to a vehicle complying with a relevant instrument is a reference to a vehicle complying]—

<sup>F395</sup>(a) if it is propelled by a compression ignition engine—

- (i) in the case of an agricultural vehicle first used before 1st January 2001, with Community Directive 77/537, or
- (ii) in the case of any other vehicle, either—
  - (aa) Community Directive 72/306, as last amended by Community Directive 2005/21, or
  - (bb) ECE Regulation 24.01, 24.02 or 24.03;] or

<sup>F396</sup>(b) if it is propelled by a spark ignition engine, with any instrument mentioned in column (4) (a) of Table II.]

<sup>F397</sup>(4A) In relation to a vehicle which—

- (a) has an engine the cylinder capacity of which is less than 700 cc and has a rated power speed of more than 3,000 revolutions per minute;

Status: Point in time view as at 31/03/2009.

Status: This revised version has been created from an electronic version contributed by Westlaw which was originally derived from the printed publication. Read more (See end of Document for details) Changes to legislation: There are currently no known outstanding effects for the The Road Vehicles (Construction and Use) Regulations 1986. (See end of Document for details)

(b) is first used before 1st October 1998,

Community Directive 91/542 shall have effect for the purposes of this regulation as if for the figure “0.15” in the Table in paragraph 6.2.1 and 8.3.1.1 there were substituted “0.25”.

For the purposes of this paragraph, “rated power speed” has the same meaning as in Community Directive 96/1.]

- (5) No person shall use, or cause or permit to be used, on a road any motor vehicle—
  - (a) from which any smoke, visible vapour, grit, sparks, ashes, cinders or oily substance is emitted if that emission causes, or is likely to cause, damage to any property or injury or danger to any person who is, or who may reasonably be expected to be, on the road;
  - (b) which is subject to the requirement in item 2 of [F391Table I] (whether or not it is deemed to comply with that requirement by virtue of paragraph (4)), if the fuel injection equipment, the engine speed governor or any other parts of the engine by which it is propelled have been altered or adjusted so as to increase the emission of smoke; or
  - (c) which is subject to the requirement in item 1 of the Table if the device mentioned in column 2 in that item is used while the vehicle is in motion.

(6) No person shall use, or cause or permit to be used, on a road a motor vehicle to which item 3 of [F391Table I] applies unless it is so maintained that the means specified in column 3 of that item are in good working order.

[F398(7) Subject to paragraphs F399 ... (8), (9) and (10), no person shall use, or cause or permit to be used, on a road a motor vehicle to which an item in Table II applies if, in relation to the emission of the substances specified in column (6) of the item, the vehicle does not comply with the requirements relating to conformity of production models specified in column (4) unless the following conditions are satisfied in respect to it—

- (a) the failure to meet those requirements in relation to the emission of those substances does not result from an alteration to the propulsion unit or exhaust system of the vehicle,
- (b) [F400neither would those requirements] be met in relation to the emission of those substances nor would such emissions be materially reduced if maintenance work of a kind which would fall within the scope of a normal periodic service of the vehicle were to be carried out on the vehicle, and
- (c) the failure to meet those requirements in relation to such emissions does not result from any device designed to control the emission of carbon monoxide, hydrocarbons, oxides of nitrogen or particulates fitted to the vehicle being other than in good and efficient working order.

- F401(7A) .....
- F401(7B) .....
- F401(7C) .....
- F401(7D) .....
- F401(7E) .....
- F401(7F) .....
- F401(7G) .....
- F401(7H) .....

(8) Paragraph (7) shall not apply to a vehicle first used before 26th June 1990.

- (9) Where—
  - (a) a vehicle is fitted with a device of the kind referred to in sub-paragraph (c) of paragraph (7),



**Status:** This revised version has been created from an electronic version contributed by Westlaw which was originally derived from the printed publication. **Read more** (See end of Document for details)**Changes to legislation:** There are currently no known outstanding effects for the The Road Vehicles (Construction and Use) Regulations 1986. (See end of Document for details)

- (b) the vehicle does not comply with the requirements specified in that paragraph in respect to it, and
- (c) the conditions specified in sub-paragraphs (a) and (b) of that paragraph are satisfied in respect to the vehicle,

nothing in paragraph (7) shall prevent the vehicle being driven to a place where the device is to be repaired or replaced.

[<sup>F402</sup>(10) Where a vehicle is constructed or assembled by a person not ordinarily engaged in the business of manufacturing motor vehicles of that description [<sup>F403</sup>and is first used before [<sup>F404</sup>1st July 1998]], the date on which it is first used shall, for the purposes of paragraphs (3A), (7), (8) and (9), be regarded as being the 1st January immediately preceding the date of manufacture of the engine by which it is propelled.

However, the date on which a vehicle is first used shall not, by virtue of the foregoing provisions of this paragraph, be regarded in any circumstances as being later than the date on which it would otherwise have been regarded as being first used had those provisions been omitted.]

[<sup>F405</sup>[<sup>F406</sup>(10A) Without prejudice to paragraphs (1) and (7) and subject to the following provisions of this regulation, no person shall use, or cause or permit to be used on a road, a vehicle first used on or after 1st August 1975 and propelled by a four-stroke spark ignition engine, if the vehicle is in such a condition and running on such fuel that—

- (a) when the engine is idling the carbon monoxide content of the exhaust emissions from the engine exceeds—
  - (i) in the case of a vehicle first used before 1st August 1986, 4.5%; or
  - (ii) in the case of a vehicle first used on or after 1st August 1986, 3.5%;of the total exhaust emissions from the engine by volume; and
- (b) when the engine is running without load at a rotational speed of 2,000 revolutions per minute, the hydrocarbon content of those emissions exceeds 0.12% of the total exhaust emissions from the engine by volume.]

[<sup>F407</sup>(10AA) Without prejudice to paragraphs (1) and (7) and subject to the following provisions of this regulation, no person shall use, or cause or permit to be used on a road, a vehicle to which this paragraph applies and which is propelled by a spark ignition engine, if the vehicle is in such a condition and running on such fuel that Part I of Schedule 7B applies to the vehicle.

(10AB) [<sup>F408</sup>Subject to paragraph (10B)], paragraph (10AA) applies to—

- (a) a passenger car which—
  - (i) is first used on or after 1st August 1992 and before [<sup>F409</sup>1st August 1995], and
  - (ii) is of a description mentioned in the Annex to the emissions publication;
- (b) a vehicle which—
  - (i) is not a passenger car,
  - (ii) is first used on or after 1st August 1994 <sup>F410</sup> ..., and
  - (iii) is of a description mentioned in the Annex to the emissions publication; <sup>F411</sup> ...
- (c) a passenger car which is first used on or after [<sup>F412</sup>1st August 1995]; <sup>F413</sup> ... [<sup>F414</sup> or]

- [ a vehicle which—  
<sup>F415</sup>(ca) (i) is not a passenger car,  
(ii) is first used on or after 1st July 2002, and

**Status:** Point in time view as at 31/03/2009.

**Status:** This revised version has been created from an electronic version contributed by Westlaw which was originally derived from the printed publication. **Read more** (See end of Document for details)**Changes to legislation:** There are currently no known outstanding effects for the The Road Vehicles (Construction and Use) Regulations 1986. (See end of Document for details)

(iii) has a maximum gross weight not exceeding 3,500kg];

<sup>F416</sup>(d) .....

and in this paragraph, “emissions publication” has the meaning given in Part I of Schedule 7B.

<sup>F417</sup>(10AC) .....

[<sup>F418</sup>(10AD) Paragraph (10A) does not apply to—

- (a) a vehicle to which paragraph (10AA) applies; or
- (b) a vehicle if, at the date that the engine was manufactured, that engine was incapable of meeting the requirements specified in that paragraph.]]

[<sup>F419</sup>(10AE) Paragraph (10AA) does not apply to a vehicle if, at the date that the engine was manufactured, that engine was incapable of meeting the requirements specified in that paragraph.]

(10B) [<sup>F420</sup>Paragraphs (10A) and (10AA) do not] apply to—

- <sup>F421</sup>(a) .....
- (b) a vehicle being driven to a place where it is to undergo repairs;
- (c) a vehicle which was constructed or assembled by a person not ordinarily engaged in the business of manufacturing motor vehicles of that description [<sup>F422</sup>and is first used before [<sup>F423</sup>1st July 1998]];
- (d) an exempt vehicle within the meaning given by paragraph (12)(a) <sup>F424</sup> ...;
- (e) a goods vehicle with a maximum gross weight exceeding 3,500 kg;
- (f) engineering plant, an industrial tractor, or a works truck; <sup>F425</sup> ...
- <sup>F426</sup>(g) ..... [<sup>F427</sup>or
- (h) a vehicle first used before 1st August 1987 if the engine is a rotary piston engine; and for the purposes of this paragraph “the engine”, in relation to a vehicle, means the engine by which it is propelled.]]

[<sup>F428</sup>(10BA) Without prejudice to paragraphs (1) and (7), no person shall use, or cause or permit to be used on a road, a vehicle propelled by a compression ignition engine, if the vehicle is in such a condition and running on such fuel that Part II of Schedule 7B applies to the vehicle.

(10BB) Paragraph (10BA) shall not apply to—

- (a) a vehicle if, at the date that the engine was manufactured, that engine was incapable of meeting the requirements specified in that paragraph;
- (b) a vehicle being driven to a place where it is to undergo repairs;
- (c) an exempt vehicle within the meaning given by paragraph (12)(a);
- (d) engineering plant, an industrial tractor or a works truck; and
- (e) a vehicle in Class III, IV, V [<sup>F429</sup>, VI] or VII within the meaning of the Motor Vehicles (Tests) Regulations 1981 and first used before 1st August 1979.

<sup>F430</sup>(10BC) .....

[<sup>F431</sup>(10C) For the purposes of this regulation—

- (a) any rotary piston engine shall be deemed to be a four-stroke engine; and

**Status:** This revised version has been created from an electronic version contributed by Westlaw which was originally derived from the printed publication. **Read more** (See end of Document for details)**Changes to legislation:** There are currently no known outstanding effects for the The Road Vehicles (Construction and Use) Regulations 1986. (See end of Document for details)

(b) “rotary piston engine” means an engine in which the torque is provided by means of one or more rotary pistons and not by any reciprocating piston.]

(11) [<sup>F432</sup>Subject to Schedule 7XA,] in this regulation, a reference to a vehicle to which an item in Table II applies is a reference to a vehicle which—

- (a) is of a class specified in that item in column (2) of that Table,
- (b) is first used on or after the date specified in that item in column (3) of that Table, and
- (c) is not exempted by the entry in that item in column (5) of that Table.

[<sup>F433</sup>and for the purposes of determining whether a vehicle is a vehicle to which [<sup>F434</sup>any item numbered 8 or more] in that Table applies, regulation 4(2) shall be disregarded]

[<sup>F435</sup>(11A) In this regulation, “passenger car” means a motor vehicle which—

- (a) is constructed or adapted for use for the carriage of passengers and is not a goods vehicle;
- (b) has no more than five seats in addition to the driver’s seat; and
- (c) has a maximum gross weight not exceeding 2,500kg.]

(12) In Table II [<sup>F436</sup>and paragraphs (10B) and (10BB)]—

- (a) “exempt vehicle” means—
  - (i) a vehicle with less than 4 wheels,
  - (ii) a vehicle with a maximum gross weight of less than 400 kg,
  - (iii) a vehicle with a maximum speed of less than 25 km/h, or
  - (iv) an agricultural motor vehicle;
- (b) “direct injection” means a fuel injection system in which the injector communicates with an open combustion chamber or the main part of a divided combustion chamber.
- (c) “indirect injection” means a fuel injection system in which the injector communicates with the subsidiary part of a divided combustion chamber.
- (d) a reference in column (5) to a vehicle complying with an item is a reference to a vehicle that complies with the provisions specified in that item in column (4) whether the vehicle is or is not within the class of vehicles to which that item applies and any instrument mentioned in that item shall for the purposes of the reference have effect as if it applied to the vehicle in question (whether it would otherwise have done so or not).]

[<sup>F437</sup>Table I]

(regulation 61(3))

<i>1</i> <i>Item</i>	<i>2</i> <i>Class of vehicle</i>	<i>3</i> <i>Requirements</i>	<i>4</i> <i>Exemptions</i>
1	Vehicles propelled by a compression ignition engine and equipped with a device designed to facilitate starting the engine by causing it to be supplied with excess fuel.	Provision shall be made to ensure the device cannot readily be operated by a person inside the vehicle.	(a) a work truck; (b) a vehicle on which the device is so designed and maintained that— <ul style="list-style-type: none"> <li>(i) its use after the engine has started cannot cause the engine to be supplied with excess fuel, or</li> <li>(ii) it does not cause any increase in the smoke</li> </ul>

**Status:** Point in time view as at 31/03/2009.

**Status:** This revised version has been created from an electronic version contributed by Westlaw which was originally derived from the printed publication. **Read more** (See end of Document for details) **Changes to legislation:** There are currently no known outstanding effects for the The Road Vehicles (Construction and Use) Regulations 1986. (See end of Document for details)

1 Item	2 Class of vehicle	3 Requirements	4 Exemptions or visible vapour emitted from the vehicle.
2	Vehicles first used on or after 1st April 1973 and propelled by a compression ignition engine.	The engine of the vehicle shall be of a type for which there has been issued by a person authorised by the Secretary of State a type test certificate in accordance with the British Standard Specification for the Performance of Diesel Engines for Road Vehicles published on 19th May 1971 under number BS AU 141a: 1971. In the case of an agricultural motor vehicle (other than one which is first used after 1st June 1986 and is driven at more than 20 mph), an industrial tractor, a works truck or engineering plant, for the purposes of that Specification as to the exhaust gas opacity, measurements shall be made with the engine running at 80% of its full load over the speed range from maximum speed down to the speed at which maximum torque occurs as declared by the manufacturer of the vehicle for those purposes.	<p>(a) a vehicle manufactured before 1st April 1973 and propelled by an engine known as the Perkins 6.354 engine;</p> <p>(b) a vehicle propelled by an engine having not more than 2 cylinders and being an agricultural motor vehicle (other than one which is first used on or after 1st June 1986 and which is driven at more than 20 mph), an industrial tractor, a works truck or engineering plant.</p>
3	Vehicles first used on or after 1st January 1972 and propelled by a spark ignition engine other than a 2-stroke engine.	The engine shall be equipped with means sufficient to ensure that, while the engine is running, any vapours or gases in the engine crank case, or in any other part of the engine to which vapours or gases may	<p>(a) a two-wheeled motor cycle with or without a sidecar attached;</p> <p><sup>F438</sup> ...</p> <p>(c) [<sup>F439</sup> a vehicle to which any item in Table II applies.]</p>

**Status:** Point in time view as at 31/03/2009.

**Status:** This revised version has been created from an electronic version contributed by Westlaw which was originally derived from the printed publication. **Read more** (See end of Document for details)**Changes to legislation:** There are currently no known outstanding effects for the The Road Vehicles (Construction and Use) Regulations 1986. (See end of Document for details)

1 <i>Item</i>	2 <i>Class of vehicle</i>	3 <i>Requirements</i>	4 <i>Exemptions</i>
F440 ...		pass from that case, are prevented, so far as is reasonably practicable, from escaping into the atmosphere otherwise than through the combustion chamber of the engine.	

[<sup>F441</sup>TABLE II

(regulation 61(3A), (3C), (7), (11) and (12))

(1) <i>Item</i>	(2) <i>Class of Vehicle</i>	(3) <i>Date of First Use</i>	(4) <i>Design, construction and equipment requirements</i>		(5) <i>Vehicles exempted from requirements</i>	(6) <i>Emitted substances</i>
			(a) <i>Instrument</i>	(b) <i>Place in instrument where requirements are stated</i>		
1	Vehicles propelled by a spark ignition engine.	1st October 1982	Community Directive 78/665  or  ECE Regulation 15.03	Annex I, paragraphs 3 and 5.  Paragraphs 5, 8 and 11.	(a) A carbon monoxide, hydrocarbons and oxides of nitrogen weight exceeds 3,500 kg;	(b) A vehicle which complies with the requirements of item 2, 4, 5,

**Status:** Point in time view as at 31/03/2009.

**Status:** This revised version has been created from an electronic version contributed by Westlaw which was originally derived from the printed publication. **Read more** (See end of Document for details)**Changes to legislation:** There are currently no known outstanding effects for the The Road Vehicles (Construction and Use) Regulations 1986. (See end of Document for details)

(1) Item	(2) Class of Vehicle	(3) Date of First Use	(4) Design, construction and equipment requirements	(a) Instrument	(b) Place in instrument where requirements are stated	(5) Vehicles exempted from requirements	(6) Emitted substances
2	All vehicles.	1st April 1991	Community Directive 83/351 or ECE Regulation 15.04	Annex I, paragraphs 5, 7 and 8. Paragraphs 5, 8 and 12.	<p>(c) A vehicle whose maximum speed is less than 50 km/h;</p> <p>(d) An exempt vehicle.</p>	8, 11, 12 or 13;	<p>(a) Carbon monoxide, hydrocarbons and oxides of nitrogen.</p> <p>(b) A vehicle</p>

**Status:** Point in time view as at 31/03/2009.

**Status:** This revised version has been created from an electronic version contributed by Westlaw which was originally derived from the printed publication. **Read more** (See end of Document for details)**Changes to legislation:** There are currently no known outstanding effects for the The Road Vehicles (Construction and Use) Regulations 1986. (See end of Document for details)

(1) Item	(2) Class of Vehicle	(3) Date of First Use	(4) Design, construction and equipment requirements (a) Instrument (b) Place in instrument where requirements are stated	(5) Vehicles exempted from requirements	(6) Emitted substances
					<p>which complies with the requirements of item 4, 5, 8, 11, 12 or 13;</p> <p>(c) A vehicle within the meaning given by Article 1 of Community Directive 88/77 and which complies with the requirements of item 6, 9,</p>

**Status:** Point in time view as at 31/03/2009.

**Status:** This revised version has been created from an electronic version contributed by Westlaw which was originally derived from the printed publication. **Read more** (See end of Document for details)**Changes to legislation:** There are currently no known outstanding effects for the The Road Vehicles (Construction and Use) Regulations 1986. (See end of Document for details)

(1) Item	(2) Class of Vehicle	(3) Date of First Use	(4) Design, construction and equipment requirements		(5) Vehicles exempted from requirements	(6) Emitted substances
			(a) Instrument	(b) Place in instrument where requirements are stated		
3	Industrial tractors, works trucks and engineering plant propelled in each case by a compression ignition engine.	1st April 1993	ECE Regulation 49	Paragraphs 5 and 7.	A vehicle which complies with the requirements of item 6, 9, 10, 11, 12 or 13.	Carbon monoxide, hydrocarbons and oxides of nitrogen.



Status: This revised version has been created from an electronic version contributed by Westlaw which was originally derived from the printed publication. Read more (See end of Document for details) Changes to legislation: There are currently no known outstanding effects for the The Road Vehicles (Construction and Use) Regulations 1986. (See end of Document for details)

(1) Item	(2) Class of Vehicle	(3) Date of First Use	(4) Design, construction and equipment requirements	(a) Instrument (b) Place in instrument where requirements are stated	(5) Vehicles exempted from requirements	(6) Emitted substances
4	Passenger vehicles which— (a) are constructed or adapted to carry not more than 5 passengers excluding the driver, and (b) have a maximum gross weight of not more than 2,500 kg, not being off-road vehicles.	1st April 1991	Community Directive 88/76 or Community Directive 89/458 or ECE Regulation 83	Annex I, paragraphs 5, 7 and 8. Annex I, paragraphs 5, 7 and 8. Paragraphs 5, 8 and 13.	(a) A carbon vehicle which complies with the requirements of item 2, 8, 11, 12 or 13; (b) A vehicle whose maximum speed is less than 50 km/h; (c) An exempt vehicle.	(a) Carbon monoxide, hydrocarbons and oxides of nitrogen.
5	Vehicles which are not of a description specified in item 4 but which—	1st April 1992 1st April 1991	Community Directive 88/76 or	Annex I, paragraphs 5, 7 and 8. Paragraphs 5, 8 and 13.	(a) A carbon vehicle which complies with the meaning given by Article	(a) Carbon monoxide, hydrocarbons and oxides of nitrogen.

**Status:** Point in time view as at 31/03/2009.

**Status:** This revised version has been created from an electronic version contributed by Westlaw which was originally derived from the printed publication. **Read more** (See end of Document for details)**Changes to legislation:** There are currently no known outstanding effects for the The Road Vehicles (Construction and Use) Regulations 1986. (See end of Document for details)

(1) Item	(2) Class of Vehicle	(3) Date of First Use	(4) Design, construction and equipment requirements (a) Instrument (b) Place in instrument where requirements are stated	(5) Vehicles exempted from requirements	(6) Emitted substances
	(a) are propelled by a spark ignition engine and have a maximum gross weight of not more than 2,000 kg,	ECE Regulation 83		1 of Community Directive 88/77 and which complies with the requirements of item 6, 9, 10, 11, 12 or 13;	
	or (b) are propelled by a compression ignition engine and have a maximum gross weight of more than 3,500 kg.			(b) An industrial tractor, works truck or engineering plant;	
				(c) A vehicle whose maximum speed is less than 50	

**Status:** Point in time view as at 31/03/2009.

**Status:** This revised version has been created from an electronic version contributed by Westlaw which was originally derived from the printed publication. **Read more** (See end of Document for details)**Changes to legislation:** There are currently no known outstanding effects for the The Road Vehicles (Construction and Use) Regulations 1986. (See end of Document for details)

(1) Item	(2) Class of Vehicle	(3) Date of First Use	(4) Design, construction and equipment requirements		(5) Vehicles exempted from requirements	(6) Emitted substances
			(a) Instrument	(b) Place in instrument where requirements are stated		
						km/h;
					(d)	A vehicle which complies with the requirements of item 8;
					(e)	An exempt vehicle.
6	All vehicles propelled by compression ignition engines.	1st April 1991	Community Directive 88/77 or ECE Regulation 49.01	Annex I, paragraphs 6, 7 and 8. Paragraphs 5, 6 and 7.	(a)	A (a) Carbon monoxide, hydrocarbons and oxides of nitrogen. gross weight is less than 3,500 kg and which complies with the requirements of item 2;
					(b)	A vehicle

**Status:** Point in time view as at 31/03/2009.

**Status:** This revised version has been created from an electronic version contributed by Westlaw which was originally derived from the printed publication. **Read more** (See end of Document for details)**Changes to legislation:** There are currently no known outstanding effects for the The Road Vehicles (Construction and Use) Regulations 1986. (See end of Document for details)

(1) Item	(2) Class of Vehicle	(3) Date of First Use	(4) Design, construction and equipment requirements (a) Instrument (b) Place in instrument where requirements are stated	(5) Vehicles exempted from requirements	(6) Emitted substances
					<p>which complies with the requirements of item 4, 5, 8, 9, 10, 11, 12 or 13;</p> <p>(c) A fire appliance which is first used before 1st October 1992;</p> <p>(d) An industrial tractor, works truck or engineering plant;</p>

Status: This revised version has been created from an electronic version contributed by Westlaw which was originally derived from the printed publication. **Read more** (See end of Document for details) **Changes to legislation:** There are currently no known outstanding effects for the The Road Vehicles (Construction and Use) Regulations 1986. (See end of Document for details)

(1) Item	(2) Class of Vehicle	(3) Date of First Use	(4) Design, construction and equipment requirements	(a) Instrument	(b) Place in instrument where requirements are stated	(5) Vehicles exempted from requirements	(6) Emitted substances
7	Passenger vehicles which— (a) are constructed or adapted to carry not more than 5 passengers excluding the driver, (b) have a maximum gross weight of not more than 2,500 kg, and (c) are propelled by a compression ignition engine of the indirect	1st April 1991	Community Directive 88/436	Annex I, paragraphs 5, 7 and 8 as far as they relate to particulate emissions.	(e) An exempt vehicle. (a) A (d) particulates vehicle which complies with the requirements of item 8, 11, 12 or 13; (b) A vehicle whose maximum speed is less than 50 km/h; (c) An off-road vehicle; (d) An exempt vehicle.		

**Status:** Point in time view as at 31/03/2009.

**Status:** This revised version has been created from an electronic version contributed by Westlaw which was originally derived from the printed publication. **Read more** (See end of Document for details)**Changes to legislation:** There are currently no known outstanding effects for the The Road Vehicles (Construction and Use) Regulations 1986. (See end of Document for details)

(1) Item	(2) Class of Vehicle	(3) Date of First Use	(4) Design, construction and equipment requirements		(5) Vehicles exempted from requirements	(6) Emitted substances
			(a) Instrument	(b) Place in instrument where requirements are stated		
8	All vehicles.	31st December 1992	Community Directive 91/441  or  ECE Regulation 83.01	Annex I, paragraphs 5, 7 and 8.  Paragraphs 5, 8 and 13.	(a)	<p data-bbox="1161 887 1369 1357">A carbon vehicle, with hydrocarbons, the oxides of mean nitrogen and particulates. by Article 1 of Community Directive 88/77 and which—</p> <p data-bbox="1193 1368 1369 1872">(i) complies with the requirements of item 6 and is first used before 1st October 1993, or</p> <p data-bbox="1193 1883 1369 2016">(ii) complies with the requirements</p>

**Status:** Point in time view as at 31/03/2009.

**Status:** This revised version has been created from an electronic version contributed by Westlaw which was originally derived from the printed publication. **Read more** (See end of Document for details)**Changes to legislation:** There are currently no known outstanding effects for the The Road Vehicles (Construction and Use) Regulations 1986. (See end of Document for details)

(1) Item	(2) Class of Vehicle	(3) Date of First Use	(4) Design, construction and equipment requirements	(a) Instrument	(b) Place in instrument where requirements are stated	(5) Vehicles exempted from requirements	(6) Emitted substances
							of item 9, 10, 11, 12 or 13;
						(b) An industrial tractor, works truck or engineering plant;	
						(c) A vehicle whose maximum speed is less than 50 km/h;	
						(d) An exempt vehicle.	
9	All vehicles propelled by a compression ignition engine.	1st October 1993	Community Directive 91/542	or	Annex I, paragraphs 6, 7 and 8 (excluding line B in the Tables in sub-	(a) A carbon monoxide, hydrocarbons, particulates of nitrogen and the particulates requirements	

**Status:** Point in time view as at 31/03/2009.

**Status:** This revised version has been created from an electronic version contributed by Westlaw which was originally derived from the printed publication. **Read more** (See end of Document for details)**Changes to legislation:** There are currently no known outstanding effects for the The Road Vehicles (Construction and Use) Regulations 1986. (See end of Document for details)

(1) Item	(2) Class of Vehicle	(3) Date of First Use	(4) Design, construction and equipment requirements	(a) Instrument	(b) Place in instrument where requirements are stated	(5) Vehicles exempted from requirements	(6) Emitted substances
			ECE Regulation 49.02	paragraphs 6.2.1 and 8.3.1.1). Paragraphs 5, 6 and 7 (excluding line B in the Tables in sub-paragraphs 5.2.1 and 7.4.2.1).		of item 8, 10, 11, 12 or 13; (b) An industrial tractor, works truck or engineering plant; (c) An exempt vehicle.	
10	All vehicles propelled by a compression ignition engine.	1st October 1996	Community Directive 91/542 or ECE Regulation 49.02	Annex I, paragraphs 6, 7 and 8 (excluding line A in the Tables in sub-paragraphs 6.2.1 and 8.3.1.1). Paragraphs 5, 6 and 7 (excluding line A in the Tables in sub-paragraphs		(a) A carbon monoxide, hydrocarbons, particulates of nitrogen and the particulates. requirements of item 8, 11, 12 or 13; (b) An industrial tractor, works	



**Status:** Point in time view as at 31/03/2009.

**Status:** This revised version has been created from an electronic version contributed by Westlaw which was originally derived from the printed publication. **Read more** (See end of Document for details)**Changes to legislation:** There are currently no known outstanding effects for the The Road Vehicles (Construction and Use) Regulations 1986. (See end of Document for details)

(1) Item	(2) Class of Vehicle	(3) Date of First Use	(4) Design, construction and equipment requirements	(a) Instrument	(b) Place in instrument where requirements are stated	(5) Vehicles exempted from requirements	(6) Emitted substances
						5.2.1 and 7.4.2.1).	truck or engineering plant;
							(c) An exempt vehicle.
11	All vehicles.	1st October 1994	Community Directive 93/59 [F442 or ECE Regulation 83.02]		Annex I, paragraphs 5, 7 and 8.		(a) A carbon monoxide, hydrocarbons, the oxides of meanitrogen and giveparticulates. by Article 1 of Community Directive 88/77 and which complies with the requirements of items 9, 10, 12 or 13;
							(b) An industrial tractor, works

**Status:** Point in time view as at 31/03/2009.

**Status:** This revised version has been created from an electronic version contributed by Westlaw which was originally derived from the printed publication. **Read more** (See end of Document for details)**Changes to legislation:** There are currently no known outstanding effects for the The Road Vehicles (Construction and Use) Regulations 1986. (See end of Document for details)

(1) Item	(2) Class of Vehicle	(3) Date of First Use	(4) Design, construction and equipment requirements	(a) Instrument	(b) Place in instrument where requirements are stated	(5) Vehicles exempted from requirements	(6) Emitted substances
12	All vehicles.	1st January 1997	Community Directive 94/12 [F443 or ECE Regulation 83.03]	Annex I, paragraphs 5, 7 and 8.	<p>truck or engineering plant;</p> <p>(c) Vehicles whose maximum speed is less than 50 km/h;</p> <p>(d) An exempt vehicle.</p>	<p>(a) A Carbon monoxide, hydrocarbons, the oxides of meanitrogen and giveparticulates. by Article 1 of Community Directive 88/77 and which complies with the requirements of</p>	

Status: This revised version has been created from an electronic version contributed by Westlaw which was originally derived from the printed publication. **Read more** (See end of Document for details) **Changes to legislation:** There are currently no known outstanding effects for the The Road Vehicles (Construction and Use) Regulations 1986. (See end of Document for details)

(1) Item	(2) Class of Vehicle	(3) Date of First Use	(4) Design, construction and equipment requirements	(a) Instrument	(b) Place in instrument where requirements are stated	(5) Vehicles exempted from requirements	(6) Emitted substances
13	All vehicles.	1st October 1997	Community Directive 96/69 [F444 or ECE Regulation 83.04]	Annex I, paragraphs 5, 7 and 8.	<ul style="list-style-type: none"> <li>(b) An industrial tractor, works truck or engineering plant;</li> <li>(c) Vehicles whose maximum speed is less than 50 km/h;</li> <li>(d) An exempt vehicle.</li> </ul>	<ul style="list-style-type: none"> <li>(a) Carbon monoxide, hydrocarbons, the oxides of nitrogen and particulates.</li> </ul>	

**Status:** Point in time view as at 31/03/2009.

**Status:** This revised version has been created from an electronic version contributed by Westlaw which was originally derived from the printed publication. **Read more** (See end of Document for details)**Changes to legislation:** There are currently no known outstanding effects for the The Road Vehicles (Construction and Use) Regulations 1986. (See end of Document for details)

(1) Item	(2) Class of Vehicle	(3) Date of First Use	(4) Design, construction and equipment requirements (a) Instrument (b) Place in instrument where requirements are stated	(5) Vehicles exempted from requirements	(6) Emitted substances
					Community Directive 88/77 and which complies with the requirements of items 9, 10, or 12;
				(b) A vehicle as defined in column 2 of item 14;	
				(c) An industrial tractor, works truck or engineering plant;	
				(d) Vehicles whose maximum speed is	

**Status:** Point in time view as at 31/03/2009.

**Status:** This revised version has been created from an electronic version contributed by Westlaw which was originally derived from the printed publication. **Read more** (See end of Document for details)**Changes to legislation:** There are currently no known outstanding effects for the The Road Vehicles (Construction and Use) Regulations 1986. (See end of Document for details)

(1) Item	(2) Class of Vehicle	(3) Date of First Use	(4) Design, construction and equipment requirements		(5) Vehicles exempted from requirements	(6) Emitted substances
			(a) Instrument	(b) Place in instrument where requirements are stated		
14	Vehicles falling within (a) Class II or III, as specified in the Annex to Community Directive 96/69, of category N1, or (b) Category M and specified in footnote <sup>(2)</sup> of that Annex.	1st October 1998	Community Directive 96/69 [ <sup>F444</sup> or ECE Regulation 83.04]	Annex 1, paragraphs 5, 7 and 8.	less than 50 km/h; (e) An exempt vehicle.	Carbon monoxide, hydrocarbons, oxides of nitrogen and particulates.]

Note:  
 references to categories M and N1

**Status:** Point in time view as at 31/03/2009.

**Status:** This revised version has been created from an electronic version contributed by Westlaw which was originally derived from the printed publication. **Read more** (See end of Document for details)**Changes to legislation:** There are currently no known outstanding effects for the The Road Vehicles (Construction and Use) Regulations 1986. (See end of Document for details)

(1) Item	(2) Class of Vehicle	(3) Date of First Use	(4) Design, construction and equipment requirements (a) Instrument (b) Place in instrument where requirements are stated	(5) Vehicles exempted from requirements	(6) Emitted substances
	are to those categories as specified in Annex II of the Framework Directive.				

### Textual Amendments

- F388** Words in reg. 61(1) substituted (25.9.1995) by [The Road Vehicles \(Construction and Use\) \(Amendment\) \(No. 5\) Regulations 1995](#) (S.I. 1995/2210), regs. 1(2), **3(2)**
- F389** Words in reg. 61(1) inserted (1.11.1991) by [The Road Vehicles \(Construction and Use\) \(Amendment\) \(No. 1\) Regulations 1991](#) (S.I. 1991/1526), regs. 1, **5(2)**
- F390** Reg. 61(2A) inserted (1.1.2001) by [The Road Vehicles \(Construction and Use\) \(Amendment\) \(No. 3\) Regulations 2000](#) (S.I. 2000/3197), regs. 1, **4(2)**
- F391** Words in reg. 61(3)-(6) substituted (26.6.1990) by [The Road Vehicles \(Construction and Use\) \(Amendment\) \(No. 2\) Regulations 1990](#) (S.I. 1990/1131), regs. 1, **4(2)** (with reg. 2(2))
- F392** Reg. 61(3A) inserted (26.6.1990) by [The Road Vehicles \(Construction and Use\) \(Amendment\) \(No. 2\) Regulations 1990](#) (S.I. 1990/1131), regs. 1, **4(3)** (with reg. 2(2))
- F393** Reg. 61(3B)(3C) inserted (1.11.1991) by [The Road Vehicles \(Construction and Use\) \(Amendment\) \(No. 1\) Regulations 1991](#) (S.I. 1991/1526), regs. 1, **5(3)**
- F394** Words in reg. 61(4) substituted (1.11.1991) by [The Road Vehicles \(Construction and Use\) \(Amendment\) \(No. 1\) Regulations 1991](#) (S.I. 1991/1526), regs. 1, **5(4)**
- F395** Reg. 61(4)(a) substituted (1.12.2007) by [The Road Vehicles \(Construction and Use\) \(Amendment\) \(No. 3\) Regulations 2007](#) (S.I. 2007/3132), regs. 1(1), **2(2)**
- F396** Reg. 61(4)(b) substituted (1.10.1993) by [The Road Vehicles \(Construction and Use\) \(Amendment\) \(No. 2\) Regulations 1993](#) (S.I. 1993/2199), regs. 1, **4(2)**
- F397** Reg. 61(4A) inserted (1.10.1996) by [The Road Vehicles \(Construction and Use\) \(Amendment\) \(No. 5\) Regulations 1996](#) (S.I. 1996/2329), regs. 1, **9(2)**
- F398** Reg. 61(7)-(12) inserted (26.6.1990) by [The Road Vehicles \(Construction and Use\) \(Amendment\) \(No. 2\) Regulations 1990](#) (S.I. 1990/1131), regs. 1, **4(4)** (with reg. 2(2))
- F399** Words in reg. 61(7) omitted (1.10.1996) by virtue of [The Road Vehicles \(Construction and Use\) \(Amendment\) \(No. 5\) Regulations 1996](#) (S.I. 1996/2329), regs. 1, **9(3)**
- F400** Words in reg. 61(7)(b) substituted (31.12.1992) by [The Road Vehicles \(Construction and Use\) \(Amendment\) \(No. 5\) Regulations 1992](#) (S.I. 1992/2137), regs. 1, **3(3)**
- F401** Reg. 61(7A)-(7H) omitted (1.10.1996) by virtue of [The Road Vehicles \(Construction and Use\) \(Amendment\) \(No. 5\) Regulations 1996](#) (S.I. 1996/2329), regs. 1, **9(4)**

**Status:** This revised version has been created from an electronic version contributed by Westlaw which was originally derived from the printed publication. **Read more** (See end of Document for details)**Changes to legislation:** There are currently no known outstanding effects for the The Road Vehicles (Construction and Use) Regulations 1986. (See end of Document for details)

- F402** Reg. 61(10) substituted (31.12.1992) by The Road Vehicles (Construction and Use) (Amendment) (No. 5) Regulations 1992 (S.I. 1992/2137), regs. 1, **3(4)**
- F403** Words in reg. 61(10) inserted (1.7.1997) by The Road Vehicles (Construction And Use) (Amendment) (No. 6) Regulations 1996 (S.I. 1996/3017), regs. 1, **4(2)** (as amended by The Road Vehicles (Construction and Use) (Amendment) (No. 4) Regulations 1997 (S.I. 1997/1458), regs. 1, **2(2)**)
- F404** Words in reg. 61(10) substituted (30.4.1998) by The Road Vehicles (Construction and Use) (Amendment No. 2) Regulations 1998 (S.I. 1998/1000), regs. 1, **2(2)**
- F405** Reg. 61(10A)(10B) inserted (1.11.1991) by The Road Vehicles (Construction and Use) (Amendment) (No. 1) Regulations 1991 (S.I. 1991/1526), regs. 1, **5(5)**
- F406** Reg. 61(10A) substituted (25.9.1995) by The Road Vehicles (Construction and Use) (Amendment) (No. 5) Regulations 1995 (S.I. 1995/2210), regs. 1(2), **3(3)**
- F407** Reg. 61(10AA)-(10AD) inserted (1.1.1996) by The Road Vehicles (Construction and Use) (Amendment) (No. 5) Regulations 1995 (S.I. 1995/2210), regs. 1(2), **3(4)**
- F408** Words in reg. 61(10AB) substituted (1.8.1998) by The Road Vehicles (Construction and Use) (Amendment) (No. 5) Regulations 1998 (S.I. 1998/1563), regs. 1, **3(2)(a)**
- F409** Words in reg. 61(10AB)(a) substituted (1.8.1998) by The Road Vehicles (Construction and Use) (Amendment) (No. 5) Regulations 1998 (S.I. 1998/1563), regs. 1, **3(2)(b)**
- F410** Words in reg. 61(10AB)(b) omitted (2.9.1996) by virtue of The Road Vehicles (Construction And Use) (Amendment) (No. 4) Regulations 1996 (S.I. 1996/2085), regs. 1, **3(2)(a)**
- F411** Word in reg. 61(10AB) omitted (1.1.2004) by virtue of The Road Vehicles (Construction and Use) (Amendment) (No. 5) Regulations 2003 (S.I. 2003/3145), regs. 1, **4(a)**
- F412** Words in reg. 61(10AB)(c) substituted (1.8.1998) by The Road Vehicles (Construction and Use) (Amendment) (No. 5) Regulations 1998 (S.I. 1998/1563), regs. 1, **3(2)(b)**
- F413** Word in reg. 61(10AB)(c) omitted (2.9.1996) by virtue of The Road Vehicles (Construction And Use) (Amendment) (No. 4) Regulations 1996 (S.I. 1996/2085), regs. 1, **3(2)(b)**
- F414** Word in reg. 61(10AB) inserted (1.1.2004) by The Road Vehicles (Construction and Use) (Amendment) (No. 5) Regulations 2003 (S.I. 2003/3145), regs. 1, **4(b)**
- F415** Reg. 61(10AB)(ca) added (1.1.2004) by The Road Vehicles (Construction and Use) (Amendment) (No. 5) Regulations 2003 (S.I. 2003/3145), regs. 1, **4(c)**
- F416** Reg. 61(10AB)(d) omitted (2.9.1996) by virtue of The Road Vehicles (Construction And Use) (Amendment) (No. 4) Regulations 1996 (S.I. 1996/2085), regs. 1, **3(2)(c)**
- F417** Reg. 61(10AC) omitted (1.8.1998) by virtue of The Road Vehicles (Construction and Use) (Amendment) (No. 5) Regulations 1998 (S.I. 1998/1563), regs. 1, **3(3)**
- F418** Reg. 61(10AD) substituted (2.9.1996) by The Road Vehicles (Construction And Use) (Amendment) (No. 4) Regulations 1996 (S.I. 1996/2085), regs. 1, **3(3)**
- F419** Reg. 61(10AE) inserted (2.9.1996) by The Road Vehicles (Construction And Use) (Amendment) (No. 4) Regulations 1996 (S.I. 1996/2085), regs. 1, **3(4)**
- F420** Words in reg. 61(10B) substituted (1.1.1996) by The Road Vehicles (Construction and Use) (Amendment) (No. 5) Regulations 1995 (S.I. 1995/2210), regs. 1(2), **3(5)**
- F421** Reg. 61(10B)(a) omitted (2.9.1996) by virtue of The Road Vehicles (Construction And Use) (Amendment) (No. 4) Regulations 1996 (S.I. 1996/2085), regs. 1, **3(5)**
- F422** Words in reg. 61(10B)(c) inserted (1.7.1997) by The Road Vehicles (Construction And Use) (Amendment) (No. 6) Regulations 1996 (S.I. 1996/3017), regs. 1, **4(3)** (as amended by The Road Vehicles (Construction and Use) (Amendment) (No. 4) Regulations 1997 (S.I. 1997/1458), regs. 1, **2(2)**)
- F423** Words in reg. 61(10B)(c) substituted (30.4.1998) by The Road Vehicles (Construction and Use) (Amendment No. 2) Regulations 1998 (S.I. 1998/1000), regs. 1, **2(2)**
- F424** Word in reg. 61(10B)(d) omitted (1.1.1996) by The Road Vehicles (Construction and Use) (Amendment) (No. 5) Regulations 1995 (S.I. 1995/2210), regs. 1(2), **3(5)**
- F425** Word in reg. 61(10B)(f) omitted (31.12.1992) by virtue of The Road Vehicles (Construction and Use) (Amendment) (No. 5) Regulations 1992 (S.I. 1992/2137), regs. 1, **3(5)**
- F426** Reg. 61(10B)(g) omitted (1.2.1993) by virtue of The Road Vehicles (Construction and Use) (Amendment) (No. 8) Regulations 1992 (S.I. 1992/3285), regs. 1, **4**

**Status:** Point in time view as at 31/03/2009.

**Status:** This revised version has been created from an electronic version contributed by Westlaw which was originally derived from the printed publication. **Read more** (See end of Document for details)**Changes to legislation:** There are currently no known outstanding effects for the The Road Vehicles (Construction and Use) Regulations 1986. (See end of Document for details)

- F427** Reg. 61(10B)(h) and word inserted (31.12.1992) by The Road Vehicles (Construction and Use) (Amendment) (No. 5) Regulations 1992 (S.I. 1992/2137), regs. 1, **3(5)**
- F428** Reg. 61(10BA)-(10BC) inserted (25.9.1995) by The Road Vehicles (Construction and Use) (Amendment) (No. 5) Regulations 1995 (S.I. 1995/2210), regs. 1(2), **3(6)**
- F429** Word in reg. 61(10BB)(e) added (1.12.2007) by The Road Vehicles (Construction and Use) (Amendment) (No. 3) Regulations 2007 (S.I. 2007/3132), regs. 1(1), **2(3)**
- F430** Reg. 61(10BC) omitted (1.8.1998) by virtue of The Road Vehicles (Construction and Use) (Amendment) (No. 5) Regulations 1998 (S.I. 1998/1563), regs. 1, **3(3)**
- F431** Reg. 61(10C) inserted (31.12.1992) by The Road Vehicles (Construction and Use) (Amendment) (No. 5) Regulations 1992 (S.I. 1992/2137), regs. 1, **3(6)**
- F432** Words in reg. 61(11) inserted (1.10.1996) by The Road Vehicles (Construction and Use) (Amendment) (No. 5) Regulations 1996 (S.I. 1996/2329), regs. 1, **9(5)**
- F433** Words in reg. 61(11) inserted (31.12.1992) by The Road Vehicles (Construction and Use) (Amendment) (No. 5) Regulations 1992 (S.I. 1992/2137), regs. 1, **3(7)**
- F434** Words in reg. 61(11) substituted (25.9.1995) by The Road Vehicles (Construction and Use) (Amendment) (No. 5) Regulations 1995 (S.I. 1995/2210), regs. 1(2), **3(7)**
- F435** Reg. 61(11A) inserted (1.1.1996) by The Road Vehicles (Construction and Use) (Amendment) (No. 5) Regulations 1995 (S.I. 1995/2210), regs. 1(2), **3(8)**
- F436** Words in reg. 61(12) inserted (1.1.2001) by The Road Vehicles (Construction and Use) (Amendment) (No. 3) Regulations 2000 (S.I. 2000/3197), regs. 1, **4(4)**
- F437** Table renumbered as Table 1 (26.6.1990) by The Road Vehicles (Construction and Use) (Amendment) (No. 2) Regulations 1990 (S.I. 1990/1131), regs. 1, **4(5)** (with reg. 2(2))
- F438** Words in reg. 61 Table 1 Item 3 omitted (1.10.1993) by virtue of The Road Vehicles (Construction and Use) (Amendment) (No. 2) Regulations 1993 (S.I. 1993/2199), regs. 1, **4(6)**
- F439** Reg. 61 Table 1 words inserted (26.6.1990) by The Road Vehicles (Construction and Use) (Amendment) (No. 2) Regulations 1990 (S.I. 1990/1131), regs. 1, **4(5)(a)** (with reg. 2(2))
- F440** Reg. 61 Table 1 words omitted (26.6.1990) by virtue of The Road Vehicles (Construction and Use) (Amendment) (No. 2) Regulations 1990 (S.I. 1990/1131), regs. 1, **4(5)(b)** (with reg. 2(2))
- F441** Reg. 61 Table 2 substituted (1.8.1997) by The Road Vehicles (Construction and Use) (Amendment) (No. 5) Regulations 1997 (S.I. 1997/1544), regs. 1, 3(2), **Sch.**
- F442** Words in reg. 61 Table 2 inserted (1.1.2001) by The Road Vehicles (Construction and Use) (Amendment) (No. 3) Regulations 2000 (S.I. 2000/3197), regs. 1, **4(5)(a)**
- F443** Words in reg. 61 Table 2 inserted (1.1.2001) by The Road Vehicles (Construction and Use) (Amendment) (No. 3) Regulations 2000 (S.I. 2000/3197), regs. 1, **4(5)(b)**
- F444** Words in reg. 61 Table 2 inserted (1.1.2001) by The Road Vehicles (Construction and Use) (Amendment) (No. 3) Regulations 2000 (S.I. 2000/3197), regs. 1, **4(5)(c)**

#### Commencement Information

- I54** Reg. 61 in force at 11.8.1986, see **reg. 1**

#### [<sup>F445</sup>Emission of smoke, vapour, gases, oily substances etc—further requirements for certain motor vehicles first used on or after 1st January 2001

**61A.—(1)** This regulation shall apply to motor vehicles first used on or after 1st January 2001.

(2) Subject to paragraphs (5) to (7) and Schedule 7XA, a motor vehicle in any category shall comply with such design, construction and equipment requirements and such limit values as may be specified for a motor vehicle of that category and weight by any Community Directive specified in item 1 or 2 of the Table and from such date as is specified by that Community Directive.

(3) Subject to paragraphs (4) to (7) and Schedule 7XA, no person shall use, or cause or permit to be used, on a road a motor vehicle if the motor vehicle does not comply with such limit values as may apply to it by virtue of any Community Directive specified in item 1 or 2 of the Table, and from



**Status:** This revised version has been created from an electronic version contributed by Westlaw which was originally derived from the printed publication. **Read more** (See end of Document for details)**Changes to legislation:** There are currently no known outstanding effects for the The Road Vehicles (Construction and Use) Regulations 1986. (See end of Document for details)

such date as is specified by that Community Directive, unless the following conditions are satisfied with respect to it—

- (a) the failure to meet the limit values does not result from an alteration to the propulsion unit or exhaust system of the motor vehicle;
  - (b) neither would those limit values be met nor the emissions of gaseous and particulate pollutants and smoke and evaporative emissions be materially reduced if maintenance work of a kind which would fall within the scope of a normal periodic service of the vehicle were carried out on the motor vehicle; and
  - (c) the failure to meet those limit values does not result from any device designed to control the emission of gaseous and particulate pollutants and smoke and evaporative emissions which is fitted to the motor vehicle being other than in good and efficient working order.
- (4) [<sup>F446</sup>Where]—
- (a) a motor vehicle is fitted with a device of the kind referred to in sub-paragraph (c) of paragraph (3);
  - (b) the motor vehicle does not comply with the limit values applying to it which are referred to in that paragraph; and
  - (c) the conditions specified in sub-paragraphs (a) and (b) of paragraph (3) are satisfied in respect of the motor vehicle

nothing in [<sup>F447</sup>paragraph (3)] shall prevent the motor vehicle being driven to a place where the device is to be repaired or replaced.

(5) Subject to paragraph (6), if the Secretary of State has exempted any motor vehicle produced in a small series from one or more of the provisions of a Community Directive specified in item 1 of the Table in accordance with the procedure in Article 8(2)(a) of the Framework Directive then paragraphs (2) to (4) shall not apply to that motor vehicle insofar as it has been so exempted.

(6) If any motor vehicle has been exempted from one or more of the provisions of a Community Directive specified in item 1 of the Table in accordance with paragraph (5), then in the Table as it applies to that motor vehicle there shall be deemed to be substituted, for the reference to Community Directive 96/69/EC or ECE Regulation 83.04, Community Directive 98/69/EC and 1999/102/EC—

- (a) in the case of passenger cars as defined in regulations 61(11A), a reference to Community Directive 94/12/EC or ECE Regulation 83.03; and
- (b) in the case of other motor vehicles of category M, a reference to Community Directive 93/59/EEC or ECE Regulation 83.02

and in any such case paragraphs (2) to (4) shall apply to the motor vehicle as if they referred to the substituted Community Directives or ECE Regulations.

[<sup>F448</sup>(7) If a vehicle has, in accordance with Schedule 7XA, been exempted from the need to comply with any provision of a Community Directive specified in item 1 or 2 in the Table (“the exempted provision”), it shall, in substitution for the exempted provision, comply with the equivalent provision (if any) that would have applied by virtue of this regulation in relation to such a vehicle immediately before the coming into force of the requirement to comply with the exempted provision; and in relation to that equivalent provision paragraphs 2 to 4 shall apply as if they referred to the Community Directive under which that equivalent provision arose.]

(8) In this regulation—

- (a) “category” means a category for the purpose of Annex II of the Framework Directive;

[<sup>F449</sup>(b) “date as is specified” means, in relation to any vehicle and—

- (i) in relation to limit values set by a Community Directive specified in item 1 or 2 in the Table, the date specified by that Community Directive as that from which Member

**Status:** Point in time view as at 31/03/2009.

**Status:** This revised version has been created from an electronic version contributed by Westlaw which was originally derived from the printed publication. **Read more** (See end of Document for details) **Changes to legislation:** There are currently no known outstanding effects for the The Road Vehicles (Construction and Use) Regulations 1986. (See end of Document for details)

States are required to prohibit the registration or the entry into service of that vehicle if it does not comply with those limit values; or

- (ii) in relation to emission control and monitoring systems and devices, the date specified by a Community Directive specified in item 1 or 2 in the Table as that from which Member States are required to ensure that such equipment is fitted to that vehicle, provided that, where a Community Directive specified in item 2 in the Table re-enacts a requirement imposed by a Community Directive that had been specified in that item immediately before 9th November 2006, the date as is specified shall be the date that had been specified by that previous Directive;]
- (c) “limit values” means the permitted amounts of gaseous and particulate pollutants and smoke and evaporative emissions;
- (d) “small series” means the motor vehicles within a family of types as defined in Annex XII of the Framework Directive which are registered or enter into service in a period of twelve months beginning on 1st January in any year where the total number of motor vehicles does not exceed the small series limits specified in that Annex.

[<sup>F450</sup>(9) Regulation 4(2) does not apply to any requirement imposed on a vehicle by or under this Regulation.]

**TABLE**

(Regulation 61A)

<i>Item</i>	<i>Community Directive or ECE Regulation</i>	<i>Amending Community Directive or ECE Regulation</i>
1.	70/220/EEC	96/69/EC or ECE Regulation 83.04  98/69/EC  1999/102/EC  [ <sup>F451</sup> 2001/1/EC]
[ <sup>F452</sup> 2.	2005/55/EC or ECE Regulation 49.02	2005/78/EC  2006/51/EC]]

#### Textual Amendments

- F445** Reg. 61A inserted (1.1.2001) by The Road Vehicles (Construction and Use) (Amendment) (No. 3) Regulations 2000 (S.I. 2000/3197), regs. 1, **5(1)**
- F446** Word in reg. 61A(4) substituted (16.10.2001) by The Road Vehicles (Construction and Use) (Amendment) (No. 4) Regulations 2001 (S.I. 2001/3208), regs. 1(2), **10**
- F447** Words in reg. 61A(4) substituted (1.3.2001) by The Road Vehicles (Construction and Use) (Amendment) Regulations 2001 (S.I. 2001/306), regs. 1, **3**
- F448** Reg. 61A(7) substituted (20.10.2006) by The Road Vehicles (Construction and Use) and Motor Vehicles (Type Approval for Goods Vehicles) (Great Britain) (Amendment) Regulations 2006 (S.I. 2006/2565), regs. 1(2), **4(2)**

**Status:** This revised version has been created from an electronic version contributed by Westlaw which was originally derived from the printed publication. **Read more** (See end of Document for details)**Changes to legislation:** There are currently no known outstanding effects for the The Road Vehicles (Construction and Use) Regulations 1986. (See end of Document for details)

- F449** Reg. 61A(8)(b) substituted (20.10.2006) by The Road Vehicles (Construction and Use) and Motor Vehicles (Type Approval for Goods Vehicles) (Great Britain) (Amendment) Regulations 2006 (S.I. 2006/2565), regs. 1(2), **4(3)**
- F450** Reg. 61A(9) added (20.10.2006) by The Road Vehicles (Construction and Use) and Motor Vehicles (Type Approval for Goods Vehicles) (Great Britain) (Amendment) Regulations 2006 (S.I. 2006/2565), regs. 1(2), **4(4)**
- F451** Words in reg. 61A Table inserted (1.8.2001) by The Road Vehicles (Construction and Use) (Amendment) (No. 3) Regulations 2001 (S.I. 2001/1825), regs. 1, **3**
- F452** Reg. 61A Table Item 2 substituted (9.11.2006) by The Road Vehicles (Construction and Use) and Motor Vehicles (Type Approval for Goods Vehicles) (Great Britain) (Amendment) Regulations 2006 (S.I. 2006/2565), regs. 1(2), **4(5)**

### Closets etc

**62.**—(1) No wheeled vehicle first used after 15th January 1931 shall be equipped with any closet or urinal which can discharge directly on to a road.

(2) Every tank into which a closet or urinal with which a vehicle is equipped empties, and every closet or urinal which does not empty into a tank, shall contain chemicals which are non-inflammable and non-irritant and provide an efficient germicide.

#### Commencement Information

**I55** Reg. 62 in force at 11.8.1986, see **reg. 1**

### Wings

**63.**—(1) Save as provided in paragraph (4), this regulation applies to—

- (a) invalid carriages;
- (b) heavy motor cars, motor cars and motor cycles, not being agricultural motor vehicles or pedestrian-controlled vehicles;
- (c) agricultural motor vehicles driven at more than 20 mph; and
- (d) trailers.

(2) Subject to paragraphs (3) and (5), every vehicle to which this regulation applies shall be equipped with wings or other similar fittings to catch, so far as practicable, mud or water thrown up by the rotation of its wheels or tracks.

(3) The requirements specified in paragraph (2) apply, in the case of a trailer with more than two wheels, only in respect of the rearmost two wheels.

(4) Those requirements do not apply in respect of—

- (a) a works truck;
- (b) a living van;
- (c) a water cart;
- (d) an agricultural trailer drawn by a motor vehicle which is not driven at a speed in excess of 20 mph;
- (e) an agricultural trailed appliance;
- (f) an agricultural trailed appliance conveyor;
- (g) a broken down vehicle;

**Status:** Point in time view as at 31/03/2009.

**Status:** This revised version has been created from an electronic version contributed by Westlaw which was originally derived from the printed publication. **Read more** (See end of Document for details)**Changes to legislation:** There are currently no known outstanding effects for the The Road Vehicles (Construction and Use) Regulations 1986. (See end of Document for details)

- (h) a heavy motor car, motor car or trailer in an unfinished condition which is proceeding to a workshop for completion;
  - (i) a trailer used for or in connection with the carriage of round timber and the rear wheels of any heavy motor car or motor car drawing a semi-trailer so used; or
  - (j) a trailer drawn by a motor vehicle the maximum speed of which is restricted to 20 mph or less under Schedule 6 to the 1984 Act.
- (5) Instead of complying with paragraph (2) a vehicle may comply with Community Directive 78/549.

#### Commencement Information

**I56** Reg. 63 in force at 11.8.1986, see [reg. 1](#)

### Spray suppression devices

**64.**—(1) Save as provided in paragraph (2), this regulation applies to every wheeled goods vehicle which is—

- (a) a motor vehicle first used on or after 1st April 1986 having a maximum gross weight exceeding 12,000 kg;
- (b) a trailer manufactured on or after 1st May 1985 having a maximum gross weight exceeding 3500 kg; or
- (c) a trailer, whenever manufactured, having a maximum gross weight exceeding 16,000 kg and 2 or more axles.

(2) This regulation does not apply to—

- (a) a motor vehicle so constructed that the driving power of its engine is, or can by use of its controls be, transmitted to all the wheels on at least one front axle and on at least one rear axle;
- (b) a motor vehicle of which no part which lies within the specified area is less than 400 mm vertically above the ground when the vehicle is standing on reasonably flat ground;
- (c) a works truck;
- (d) a works trailer;
- (e) a broken down vehicle;
- (f) a motor vehicle which has a maximum speed not exceeding 30 mph;
- (g) a vehicle of a kind specified in sub-paragraphs (b), (c), (d), (e), (f), (g), (h), (j), (k), (o) or (p) of regulation 51(2);
- (h) a vehicle specially designed, and not merely adapted, for the carriage and mixing of liquid concrete; or
- (i) a vehicle which is being driven or towed to a place where by previous arrangement a device is to be fitted so that it complies with the requirements specified in paragraph (3).

[<sup>F453</sup>(2A) This regulation shall not apply to a vehicle fitted with a spray-suppression system in accordance with the requirements of Annex III of Community Directive 91/226(3) if the spray suppression devices with which the vehicle is equipped are legibly and permanently marked with a designated approval mark.]

(3) A vehicle to which this regulation applies and which is of a class specified in an item in column 2 of the Table shall not be used on a road on or after the date specified in column 3 in that item, unless it is fitted in relation to the wheels on each of its axles, with such containment devices

**Status:** This revised version has been created from an electronic version contributed by Westlaw which was originally derived from the printed publication. **Read more** (See end of Document for details) **Changes to legislation:** There are currently no known outstanding effects for the The Road Vehicles (Construction and Use) Regulations 1986. (See end of Document for details)

as satisfy the technical requirements and other provisions about containment devices specified in the British Standard Specification, provided that in the case of a containment device fitted before 1st January 1985 the said requirements shall be deemed to be complied with if that containment device substantially conforms to those requirements.

TABLE

(regulation 64(3))

<i>1</i> <i>Item</i>	<i>2</i> <i>Class of Vehicle</i>	<i>3</i> <i>Date</i>
1	A trailer manufactured before 1st January 1975	1st October 1987
2	A trailer manufactured on or after 1st January 1975 but before 1st May 1985	1st October 1986
3	A trailer manufactured on or after 1st May 1985	1st May 1985
4	A motor vehicle	1st April 1986

(4) In this regulation—

[<sup>F454</sup>“the British Standard Specification” means—

- (a) in relation to a containment device fitted before 1st May 1987, Part 1a of the amended Specification and Part 2 of the original Specification; and
- (b) in relation to a containment device fitted on or after 1st May 1987, Part 1a and Part 2a of the amended Specification;

[<sup>F455</sup>“designated approval mark” means the marking designated as an approval mark by regulation 5 of the Approval Marks Regulations and shown at item 30 in Schedule 4 to those Regulations;]

“the original Specification” means the British Standard Specification for Spray Reducing Devices for Heavy Goods Vehicles published under the reference BS AU 200: Part 1: 1984 and BS AU 200: Part 2: 1984;

“the amended Specification” means the original Specification as amended and published under the reference BS AU 200: Part 1a: 1986 and BS AU 200: Part 2a: 1986;

“containment device” means any device so described in the original Specification or the amended Specification;]

“the specified area” means the area formed by the overall length of the vehicle and the middle 80% of the shortest distance between the inner edges of any two wheels on opposite sides of the vehicle (such distance being ascertained when the vehicle is fitted with suitable tyres inflated to a pressure recommended by the manufacturer, but excluding any bulging of the tyres near the ground) .

(5) Nothing in this regulation derogates from any requirement specified in regulation 63.

#### Textual Amendments

**F453** Reg. 64(2A) inserted (1.4.1992) by [The Road Vehicles \(Construction and Use\) \(Amendment\) \(No. 3\) Regulations 1992 \(S.I. 1992/646\)](#), regs. 1, **2(2)**

**F454** Words in reg. 64(4) substituted (10.10.1986) by [The Road Vehicles \(Construction and Use\) \(Amendment\) Regulations 1986 \(S.I. 1986/1597\)](#), regs. 1, **4** (with reg. 3)

**F455** Words in reg. 64(4) inserted (1.4.1992) by [The Road Vehicles \(Construction and Use\) \(Amendment\) \(No. 3\) Regulations 1992 \(S.I. 1992/646\)](#), regs. 1, **2(3)**

**Status:** Point in time view as at 31/03/2009.

**Status:** This revised version has been created from an electronic version contributed by Westlaw which was originally derived from the printed publication. **Read more** (See end of Document for details)**Changes to legislation:** There are currently no known outstanding effects for the The Road Vehicles (Construction and Use) Regulations 1986. (See end of Document for details)

#### Commencement Information

**I57** Reg. 64 in force at 11.8.1986, see [reg. 1](#)

#### Maintenance of spray suppression devices

**65.** Every part of every containment device with which a vehicle is required to be fitted by the provisions of regulation 64 shall at all times when the vehicle is on a road be maintained free from any obvious defect which would be likely to affect adversely the effectiveness of the device.

#### Commencement Information

**I58** [Reg. 65](#) in force at 11.8.1986, see [reg. 1](#)

## PART III

### PLATES, MARKINGS, TESTING AND INSPECTION

#### Plates for goods vehicles and buses

- 66.**—(1) This regulation applies to—
- (a) a wheeled heavy motor car or motor car first used on or after 1st January 1968 not being—
    - (i) a dual-purpose vehicle;
    - (ii) an agricultural motor vehicle;
    - (iii) a works truck;
    - (iv) a pedestrian-controlled vehicle; <sup>F456</sup> ...
    - (v) save as provided in sub-paragraph (b) below, a passenger vehicle; <sup>F457</sup> or
    - (vi) a vehicle which is exempt from section 63(1) of the Road Traffic Act 1988 by virtue of regulation 14(6) of the Motor Vehicles (Approval) Regulations 1996.]
  - (b) a bus (whether or not it is an articulated bus) first used on or after 1st April 1982;
  - (c) a wheeled locomotive or motor tractor first used on or after 1st April 1973 not being—
    - (i) an agricultural motor vehicle;
    - (ii) an industrial tractor;
    - (iii) a works truck;
    - (iv) engineering plant; or
    - (v) a pedestrian-controlled vehicle;
  - (d) a wheeled trailer manufactured on or after 1st January 1968 which exceeds 1020 kg in weight unladen not being—
    - (i) a trailer not constructed or adapted to carry any load, other than plant or special appliances or apparatus which is a permanent or essentially permanent fixture, and not exceeding 2290 kg in total weight;
    - (ii) a living van not exceeding 2040 kg in weight unladen and fitted with pneumatic tyres;
    - (iii) a works trailer;
    - (iv) a trailer mentioned in regulation 16(3)(b) to (g); or

**Status:** This revised version has been created from an electronic version contributed by Westlaw which was originally derived from the printed publication. **Read more** (See end of Document for details)**Changes to legislation:** There are currently no known outstanding effects for the The Road Vehicles (Construction and Use) Regulations 1986. (See end of Document for details)

- (v) a trailer which was manufactured and used outside Great Britain before it was first used in Great Britain; and
- (e) a converter dolly manufactured on or after 1st January 1979.
- (2) Every vehicle to which this regulation applies shall be equipped with a plate securely attached to the vehicle in a conspicuous and readily accessible position which either—
- (a) contains the particulars required, in the case of a motor vehicle by Part I of Schedule 8 or, in the case of a trailer, by Part II of that Schedule, and complies with the provisions of Part III of that Schedule; or
- (b) complies with the requirements specified in the Annex to Community Directive 78/507 or, in the case of a vehicle first used before 1st October 1982, in the Annex to Community Directive 76/114, such requirements being in any case modified as provided in paragraph (3).
- (3) Instead of the particulars required by items 2.1.4 to 2.1.7 of that Annex, the plate required by paragraph (2)(b) shall show, for a vehicle of a class specified in column 2 of the Table against an item of that Annex so specified in column 1, the following particulars—
- (a) the maximum permitted weight for that class, if any, shown in column 3 of the Table;
- (b) where the maximum weight shown in column 4 of the Table exceeds the maximum permitted weight, the maximum weight in a column on the plate to the right of the maximum permitted weight; and
- (c) if no weight is shown in column 3 of the Table, the maximum weight shown in column 4 of the Table, in the right hand column of the plate.

**TABLE**

(regulation 66(3))

<i>1</i> <i>Item in Annex to Directive</i>	<i>2</i> <i>Class of vehicle</i>	<i>3</i> <i>Maximum permitted weight</i>	<i>4</i> <i>Maximum weight</i>
2.1.4 (Laden weight of vehicle)	(i) Motor vehicles	The maximum gross weight in Great Britain referred to in item 10 in Part I of Schedule 8.	The maximum gross weight referred to in item 7 in Part I of Schedule 8 .
	(ii) Trailers, other than semi-trailers	The maximum gross weight in Great Britain referred to in item 8 in Part II of Schedule 8.	The maximum gross weight referred to in item 6 in Part II of Schedule 8.
	(iii) Semi-trailers		The maximum gross weight referred to in item 6 in Part II of Schedule 8.
2.1.5 (Train weight of motor vehicle)	Motor vehicles constructed to draw a trailer	The lower of— (a) the maximum train weight referred to in item 8 in Part I of Schedule 8; and	The maximum train weight referred to in item 8 in Part I of Schedule 8.

**Status:** Point in time view as at 31/03/2009.

**Status:** This revised version has been created from an electronic version contributed by Westlaw which was originally derived from the printed publication. **Read more** (See end of Document for details)**Changes to legislation:** There are currently no known outstanding effects for the The Road Vehicles (Construction and Use) Regulations 1986. (See end of Document for details)

<i>1</i> <i>Item in Annex to Directive</i>	<i>2</i> <i>Class of vehicle</i>	<i>3</i> <i>Maximum permitted weight</i>	<i>4</i> <i>Maximum weight</i>
		(b) the maximum laden weight specified, in the case of vehicles constructed to form part of an articulated vehicle, in regulation 77, and, in other cases, in regulation 76.	
2.1.6 (Axle weight of vehicle)	(i) Motor vehicles	The maximum weight in Great Britain for each axle referred to in item 9 in Part I of Schedule 8 .	The maximum weight for each axle referred to in item 6 in Part I of Schedule 8 .
	(ii) Trailers	The maximum weight in Great Britain for each axle referred to in item 7 in Part II of Schedule 8.	The maximum weight for each axle referred to in item 4 in Part II of Schedule 8.
2.1.7 (Load imposed by semi-trailer)	Semi-trailers		The maximum load imposed on the drawing vehicle referred to in item 5 in Part II of Schedule 8.

(4) Part III of Schedule 8 applies for determining the relevant weights to be shown on a plate in accordance with this regulation.

[<sup>F458</sup>(5) Where, in accordance with the provisions of this regulation and of Schedule 8, a motor vehicle first used, or a trailer manufactured, after 31st December 1998, is required to be equipped with a plate showing the maximum gross weight in Great Britain or the maximum weight in Great Britain for each axle of the vehicle, the plate may instead show particulars of the maximum authorised weight for the vehicle or, as the case may be, the maximum authorised weight for each axle of the vehicle.

(6) In paragraph (5) the references to the maximum authorised weight for a vehicle and maximum authorised for each axle of a vehicle mean those weights determined in accordance with the Motor Vehicles (Authorised Weight) Regulations 1998.

(7) The plate for a vehicle which falls within paragraph (1)(a) and which is a motor vehicle first used after 31st December 1998 need not include the particulars referred to in paragraph 9 or 10 of Part I of Schedule 8.]

#### Textual Amendments

**F456** Word in reg. 66(1)(a) omitted (1.7.1997) by virtue of [The Road Vehicles \(Construction And Use\) \(Amendment\) \(No. 6\) Regulations 1996 \(S.I. 1996/3017\)](#), regs. 1, 5

**F457** Reg. 66(1)(a)(vi) and word inserted (1.7.1997) by [The Road Vehicles \(Construction And Use\) \(Amendment\) \(No. 6\) Regulations 1996 \(S.I. 1996/3017\)](#), regs. 1, 5

**F458** Reg. 66(5)-(7) inserted (1.1.1999) by [The Road Vehicles \(Construction and Use\) \(Amendment\) \(No. 7\) Regulations 1998 \(S.I. 1998/3112\)](#), regs. 1, 6



**Commencement Information**

**I59** Reg. 66 in force at 11.8.1986, see [reg. 1](#)

**Vehicle identification numbers**

**67.**—(1) This regulation applies to a wheeled vehicle which is first used on or after 1st April 1980 and to which the Type Approval (Great Britain) Regulations apply.

(2) A vehicle to which this regulation applies shall be equipped with a plate which is in a conspicuous and readily accessible position, is affixed to a vehicle part which is not normally subject to replacement and shows clearly and indelibly—

- (a) the vehicle identification number in accordance with the requirements specified—
  - (i) in the case of a vehicle first used before 1st April 1987, in paragraphs 3.1.1 and 3.1.2 of the Annex to Community Directive [76/114/EEC](#) ; or
  - (ii) in any case, in sections 3 and 4 of the Annex to Community Directive [78/507/EEC](#);
- (b) the name of the manufacturer; and
- (c) the approval reference number of either—
  - (i) the type approval certificate which relates to the vehicle model or the model variant of the vehicle model, as the case may be, issued in accordance with the provisions of regulation 9(1) of, and Part I of Schedule 3 to, the Type Approval (Great Britain) Regulations; or
  - (ii) the Minister's approval certificate which relates to the vehicle, issued in accordance with the provisions of regulation 9(2) of, and Part 1A of Schedule 4 to, the said Regulations.

Provided that the information required under sub-paragraph (c) above may be shown clearly and indelibly on an additional plate which is fitted in a conspicuous and readily accessible position and which is affixed to a vehicle part which is not normally subject to replacement.

(3) The vehicle identification number of every vehicle to which this regulation applies shall be marked on the chassis, frame or other similar structure, on the off side of the vehicle, in a clearly visible and accessible position, and by a method such as hammering or stamping, in such a way that it cannot be obliterated or deteriorate.

**Commencement Information**

**I60** Reg. 67 in force at 11.8.1986, see [reg. 1](#)

**Plates—agricultural trailed appliances**

**68.**—(1) Save as provided in paragraph (3) below, every wheeled agricultural trailed appliance manufactured on or after 1st December 1985 shall be equipped with a plate affixed to the vehicle in a conspicuous and readily accessible position and which is clearly and indelibly marked with the particulars specified in paragraph (2) below.

- (2) Those particulars are—
  - (a) the name of the manufacturer of the appliance;
  - (b) the year in which the appliance was manufactured;
  - (c) the maximum gross weight;
  - (d) the unladen weight; and

**Status:** Point in time view as at 31/03/2009.

**Status:** This revised version has been created from an electronic version contributed by Westlaw which was originally derived from the printed publication. **Read more** (See end of Document for details)**Changes to legislation:** There are currently no known outstanding effects for the The Road Vehicles (Construction and Use) Regulations 1986. (See end of Document for details)

(e) the maximum load which would be imposed by the appliance on the drawing vehicle.

(3) In the case of a towed roller consisting of several separate rollers used in combination, a single plate shall satisfy the requirement specified in paragraph (2) above.

#### Commencement Information

**I61** Reg. 68 in force at 11.8.1986, see [reg. 1](#)

#### Plates—motor cycles

**69.**—(1) This regulation applies to every motor cycle first used on or after 1st August 1977 which is not—

- (a) propelled by an internal combustion engine with a cylinder capacity exceeding 150 cc if the vehicle was first used before 1st January 1982 or 125 cc if it was first used on or after 1st January 1982;
- (b) a mowing machine; or
- (c) a pedestrian-controlled vehicle.

(2) Every vehicle to which this regulation applies shall be equipped with a plate which is securely affixed to the vehicle in a conspicuous and readily accessible position and which complies with the requirements of Schedule 9.

#### Commencement Information

**I62** Reg. 69 in force at 11.8.1986, see [reg. 1](#)

#### Ministry plates

**70.**—(1) Every goods vehicle to which the Plating and Testing Regulations apply and in respect of which a plating certificate has been issued shall, from the date specified in paragraph (2), be equipped with a Ministry plate securely affixed, so as to be legible at all times, in a conspicuous and readily accessible position, and in the cab of the vehicle if it has one.

(2) That date is in the case of—

- (a) a vehicle to which the Type Approval for Goods Vehicles Regulations apply, the date of the fourteenth day after the plate was issued; or
- (b) any other vehicle, the date by which it is required, by the said Regulations, to be submitted for examination for plating.

[<sup>F459</sup>(3) In these Regulations “Ministry plate” means a plate which—

- (a) is issued by the Secretary of State following the issue or amendment of a plating certificate; and
- (b) subject to paragraph (4), contains the particulars required by Schedule 10, 10A, 10B or 10C.

(4) Instead of particulars of the gross weight, train weight and axle weights of the vehicle to which it relates, a Ministry plate may contain particulars of the maximum authorised weight for the vehicle, maximum authorised weight for a combination of which the vehicle forms part and maximum authorised axle weights for the vehicle, determined in accordance with the Road Vehicles (Authorised Weight) Regulations 1998 and the form of the plate shall be amended accordingly.]

**Status:** This revised version has been created from an electronic version contributed by Westlaw which was originally derived from the printed publication. **Read more** (See end of Document for details)**Changes to legislation:** There are currently no known outstanding effects for the The Road Vehicles (Construction and Use) Regulations 1986. (See end of Document for details)

**Textual Amendments**

**F459** Reg. 70(3)(4) inserted (1.1.1999) by [The Road Vehicles \(Construction and Use\) \(Amendment\) \(No. 7\) Regulations 1998 \(S.I. 1998/3112\)](#), regs. 1, 7

**Commencement Information**

**I63** [Reg. 70](#) in force at 11.8.1986, see [reg. 1](#)

**Speed limiters—plates**

[<sup>F460</sup>**70A.**—(1) This regulation applies to every vehicle to which regulation 36A or 36B applies and which is fitted with a speed limiter.

(2) Every vehicle to which this regulation applies shall be equipped with a plate which meets the requirements specified in paragraph (3).

(3) <sup>F461</sup>... the requirements are that the plate is in conspicuous position in the driving compartment of the vehicle and is clearly and indelibly marked with the speed at which the speed limiter has been set.]

**Textual Amendments**

**F460** [Reg. 70A](#) substituted (1.1.1994) by [The Road Vehicles \(Construction and Use\) \(Amendment\) \(No. 3\) Regulations 1993 \(S.I. 1993/3048\)](#), regs. 1, 3(2), **Sch. Pt. II**

**F461** Words in [reg. 70A\(3\)](#) omitted (1.1.2005) by virtue of [The Road Vehicles \(Construction and Use\) \(Amendment\) \(No.2\) Regulations 2004 \(S.I. 2004/2102\)](#), regs. 1, 5

[<sup>F462</sup>**Plate relating to dimensions**

**70B.**—(1) This regulation applies to a vehicle which is not a goods vehicle fitted in accordance with regulation 70 with a Ministry plate containing the particulars required by Schedule 10A or 10C and which is either—

- (a) a bus or a heavy motor car and which was manufactured after 31st May 1998; or
- (b) a trailer used in combination with a vehicle falling within paragraph (a) and manufactured after 31st May 1998.

(2) A vehicle to which this regulation applies shall not be used unless—

- (a) the vehicle is equipped with a plate securely attached to the vehicle in a conspicuous and readily accessible position and containing the particulars as to the dimensions of the vehicle specified in Annex III of Community Directive [96/53/EC](#); or
- (b) those particulars are included in the particulars shown on the plate with which the vehicle is equipped in accordance with regulation 66.]

**Textual Amendments**

**F462** [Reg. 70B](#) inserted (1.6.1998) by [The Road Vehicles \(Construction and Use\) \(Amendment\) \(No. 3\) Regulations 1998 \(S.I. 1998/1188\)](#), regs. 1, 13

**Status:** Point in time view as at 31/03/2009.

**Status:** This revised version has been created from an electronic version contributed by Westlaw which was originally derived from the printed publication. **Read more** (See end of Document for details) **Changes to legislation:** There are currently no known outstanding effects for the The Road Vehicles (Construction and Use) Regulations 1986. (See end of Document for details)

## Marking of weights on certain vehicles

**71.**—(1) This regulation applies to a vehicle (other than an agricultural motor vehicle which is either a track-laying vehicle not exceeding 3050 kg in unladen weight or a wheeled vehicle) which is—

- (a) a locomotive;
- (b) a motor tractor;
- (c) [<sup>F463</sup>a bus] which is registered under the 1971 Act (or any enactment repealed thereby) <sup>F464</sup>...; or
- (d) an unbraked wheeled trailer, other than one mentioned in [<sup>F465</sup>regulation 16(3)(b), (bb), (bc), (c), (d), (e), (f), or (g)].

(2) There shall be plainly marked in a conspicuous place on the outside of a vehicle to which this regulation applies, on its near side—

- (a) if it is a vehicle falling in paragraph (1)(a), (b), or (c), its unladen weight; and
- (b) if it is a vehicle falling in paragraph (1)(d), its maximum gross weight.

### Textual Amendments

**F463** Words in reg. 71(1)(c) substituted (24.3.1994) by The Road Vehicles (Construction and Use) (Amendment) (No. 2) Regulations 1994 (S.I. 1994/329), regs. 1, 6

**F464** Words in reg. 71(1)(c) omitted (24.3.1994) by virtue of The Road Vehicles (Construction and Use) (Amendment) (No. 2) Regulations 1994 (S.I. 1994/329), regs. 1, 6

**F465** Words in reg. 71(1)(d) substituted (1.1.1997) by The Road Vehicles (Construction and Use) (Amendment) (No. 7) Regulations 1996 (S.I. 1996/3033), regs. 1, 6

### Commencement Information

**I64** Reg. 71 in force at 11.8.1986, see reg. 1

## [<sup>F466</sup>Marking of date of manufacture of trailers

**71A.**—(1) This regulation applies to a trailer that—

- (a) is not a motor vehicle;
- (b) is manufactured on or after 1st January 1997; and
- (c) has a maximum total design axle weight not exceeding 750 kg.

(2) The year of manufacture of every trailer to which this regulation applies shall be marked on the chassis, frame or other similar structure on the nearside of the vehicle, in a clearly visible and accessible position, and by a method such as hammering or stamping, in such a way that it cannot be obliterated or deteriorate.]

### Textual Amendments

**F466** Reg. 71A inserted (1.1.1997) by The Road Vehicles (Construction and Use) (Amendment) (No. 7) Regulations 1996 (S.I. 1996/3033), regs. 1, 7

## Additional markings

**72.**—(1) This regulation applies to every goods vehicle to which the Plating and Testing Regulations apply and for which a plating certificate has been issued.

**Status:** This revised version has been created from an electronic version contributed by Westlaw which was originally derived from the printed publication. **Read more** (See end of Document for details)**Changes to legislation:** There are currently no known outstanding effects for the The Road Vehicles (Construction and Use) Regulations 1986. (See end of Document for details)

(2) Without prejudice to the provisions of regulation 70, any weight which by virtue of regulation 80 may not be exceeded in the case of a goods vehicle to which this regulation applies may be marked on either side, or on both sides, of the vehicle.

(3) Where at any time by virtue of any provision contained in regulation 75 a goods vehicle to which this regulation applies may not be used in excess of a weight which is less than the gross weight which may not be exceeded by that vehicle by virtue of regulation 80, the first mentioned weight may be marked on either side, or on both sides, of the vehicle.

(4) Where at any time by virtue of any provision contained in regulation 76 and 77 a goods vehicle to which this regulation applies is drawing, or being drawn by, another vehicle and those vehicles may not be used together in excess of a laden weight applicable to those vehicles by virtue of any such provision, that weight may be marked on either side, or on both sides, of that goods vehicle.

#### Commencement Information

**I65** [Reg. 72](#) in force at 11.8.1986, see [reg. 1](#)

#### Test date discs

**73.**—(1) Every Ministry test date disc which is issued, following the issue of a goods vehicle test certificate, in respect of a trailer to which the Plating and Testing Regulations apply and for which a plating certificate has been issued shall be carried on the trailer in a legible condition and in a conspicuous and readily accessible position in which it is clearly visible by daylight from the near side of the road, from the date of its issue until but not beyond the date of expiry of that test certificate or the date of issue of a further test certificate for that trailer, whichever date is the earlier.

(2) In this regulation “Ministry test date disc” means a plate issued by the Secretary of State for a goods vehicle, being a trailer, following the issue of a goods vehicle test certificate for that trailer under the Plating and Testing Regulations and containing the following particulars—

- (a) the identification mark allotted to that trailer and shown in that certificate;
- (b) the date until which that certificate is valid; and
- (c) the number of the vehicle testing station shown in that certificate.

#### Commencement Information

**I66** [Reg. 73](#) in force at 11.8.1986, see [reg. 1](#)

#### Testing and Inspection

**74.**—(1) Subject to the conditions specified in paragraph (2), the following persons are hereby empowered to test and inspect the brakes, silencers, steering gear and tyres of any vehicle, on any premises where that vehicle is located—

- (a) a police constable in uniform;
- (b) a person appointed by the Commissioner of Police of the Metropolis to inspect public carriages for the purpose of the Metropolitan Public Carriage Act 1869;
- (c) a person appointed by the police authority for a police area to act for the purposes of section 53 of the 1972 Act;
- (d) a goods vehicle examiner as defined in section 56 of the 1972 Act;
- (e) a certifying officer as defined in section 7(1) of the 1981 Act; and

**Status:** Point in time view as at 31/03/2009.

**Status:** This revised version has been created from an electronic version contributed by Westlaw which was originally derived from the printed publication. **Read more** (See end of Document for details)**Changes to legislation:** There are currently no known outstanding effects for the The Road Vehicles (Construction and Use) Regulations 1986. (See end of Document for details)

- (f) a public service vehicle examiner appointed as mentioned in section 7(2) of the 1981 Act.
- (2) Those conditions are—
- (a) any person empowered as there mentioned shall produce his authorisation if required to do so;
- (b) no such person shall enter any premises unless the consent of the owner of those premises has first been obtained;
- (c) no such person shall test or inspect any vehicle on any premises unless—
- (i) the owner of the vehicle consents thereto;
- (ii) notice has been given to that owner personally or left at his address not less than 48 hours before the time of the proposed test or inspection, or has been sent to him at least 72 hours before that time by the recorded delivery service to his address last known to the person giving the notice; or
- (iii) the test or inspection is made within 48 hours of an accident to which section 25 of the 1972 Act applies and in which the vehicle was involved.
- (3) For the purposes of this regulation, the owner of the vehicle shall be deemed to be in the case of a vehicle—
- (a) which is for the time being registered under the 1971 Act, and is not being used under a trade licence under that Act the person appearing as the owner of the vehicle in the register kept by the Secretary of State under that Act;
- (b) used under a trade licence, the holder of the licence; or
- (c) exempt from excise duty by virtue of the Motor Vehicles (International Circulation) Order 1975, the person resident outside the United Kingdom who has brought the vehicle into Great Britain;

and in cases (a) and (b) the address of the owner as shown on the said register or, as the case may be, on the licence may be treated as his address.

**Modifications etc. (not altering text)**

**C4** [Reg. 74](#) applied (1.11.1989) by [The Road Vehicles Lighting Regulations 1989 \(S.I. 1989/1796\)](#), regs. 1(1), **28** (with [reg. 4\(3\)](#))

**Commencement Information**

**I67** [Reg. 74](#) in force at 11.8.1986, see [reg. 1](#)

## PART IV

### CONDITIONS RELATING TO USE

#### A

#### LADEN WEIGHT

##### Maximum permitted laden weight of a vehicle

**75.**—(1) Save as provided in paragraph (2), the laden weight of a vehicle of a class specified in an item in column 2 of the Table shall not exceed the maximum permitted laden weight specified in that item in column 3.

**Status:** This revised version has been created from an electronic version contributed by Westlaw which was originally derived from the printed publication. **Read more** (See end of Document for details) **Changes to legislation:** There are currently no known outstanding effects for the The Road Vehicles (Construction and Use) Regulations 1986. (See end of Document for details)

(2) The maximum permitted laden weight of a vehicle first used before 1st June 1973 which falls in item 1 or 2 shall not be less than would be the case if the vehicle fell in item 9.

TABLE

(regulation 75(1))

<i>1</i> <i>Item</i>	<i>2</i> <i>Class of vehicle</i>	<i>3</i> <i>Maximum permitted laden weight</i> <i>(kg)</i>
1	A wheeled heavy motor car or motor car which is not described in items [F467 1A, 2,] 4 or 5 and which complies with the relevant braking requirement [F468 (see regulation 78(3) to (6) in relation to buses)]	[F469] The weight determined in accordance with Part I of Schedule 11]
[F470 1A	A wheeled heavy motor car or motor car which is not described in item 2, 4, or 5, which complies with the relevant braking requirement and in which— (a) every driving axle not being a steering axle is fitted with twin tyres; and (b) either every driving axle is fitted with road friendly suspension or no axle has an axle weight exceeding 9,500kg.	The weight determined in accordance with Part IA of Schedule 11]
2	A wheeled heavy motor car or motor car (not being an agricultural motor vehicle) which forms part of an articulated vehicle and which complies with the relevant braking requirement	The weight specified in column (5) in Part II of Schedule 11 in the item which is appropriate having regard to columns (2), (3) and (4) in that Part
3	A wheeled trailer, including a composite trailer, but not including a semi-trailer, which is drawn by a motor tractor, heavy motor car or motor car which complies with the relevant braking requirement, other than a trailer described in items 6, 7, 8 or 11	As for item 1
[F471 4	An articulated bus (see regulation 78(3) to (5))	27,000]
5	A wheeled agricultural motor vehicle	As for item 1, but subject to a maximum of 24,390
6	A balanced agricultural trailer, as defined in paragraph (4), which is not described in items 8, 11 or 16	As for item 1, but subject to a maximum of 18,290
7	An unbalanced agricultural trailer, as defined in paragraph (4) which is not described in items 8, 11 or 16	18,290 inclusive of the weight imposed by the trailer on the drawing vehicle

**Status:** Point in time view as at 31/03/2009.

**Status:** This revised version has been created from an electronic version contributed by Westlaw which was originally derived from the printed publication. **Read more** (See end of Document for details)**Changes to legislation:** There are currently no known outstanding effects for the The Road Vehicles (Construction and Use) Regulations 1986. (See end of Document for details)

1 Item	2 Class of vehicle	3 Maximum permitted laden weight (kg)
8	A wheeled trailer manufactured on or after 27th February 1977 and fitted with brakes which automatically come into operation on the over-run of the trailer (whether or not it is fitted with any other brake), except an agricultural trailer which is being drawn by an agricultural motor vehicle, which complies with the requirements specified in items 3, 14 and 17 of Schedule 3 and of which the brakes can be applied either by the driver of the drawing vehicle or by some other person on that vehicle or on the trailer	3,500
9	A wheeled heavy motor car or motor car not described in items 1, 2, 4 or 5—	
	(a) with not more than 4 wheels	14,230
	(b) with more than 4 but not more than 6 wheels	20,330
	(c) with more than 6 wheels	24,390
10	A wheeled trailer not described in items 3, 6, 7, 8 or 11 having less than 6 wheels, and not forming part of an articulated vehicle; and an agricultural trailed appliance	14,230
11	A trailer manufactured before 27th February 1977 and having no brakes other than—	
	(i) a parking brake and	
	(ii) brakes which come into operation on the overrun of the trailer	3,560
12	A wheeled locomotive, not described in item 5, which is equipped with suitable and sufficient springs between each wheel and the vehicle's frame and with a pneumatic tyre or a tyre of soft or elastic material fitted to each wheel—	
	(a) if having less than 6 wheels	22,360
	(b) if having 6 wheels	26,420
	(c) if having more than 6 wheels	30,490
13	A track-laying locomotive with resilient material interposed between the rims	22,360



**Status:** This revised version has been created from an electronic version contributed by Westlaw which was originally derived from the printed publication. **Read more** (See end of Document for details) **Changes to legislation:** There are currently no known outstanding effects for the The Road Vehicles (Construction and Use) Regulations 1986. (See end of Document for details)

1 Item	2 Class of vehicle	3 Maximum permitted laden weight (kg)
	of the weight-carrying rollers and the road so that the weight of the vehicle (other than that borne by any wheels and the portion of the track in contact with the road) is supported by the resilient material.	
14	A locomotive not described in items 5, 12 or 13	20,830
15	A track-laying heavy motor car or motor car	22,360
16	A track-laying trailer	13,210

(3) The maximum total weight of all trailers, whether laden or unladen, drawn at any one time by a locomotive shall not exceed [<sup>F472</sup>44,000 kg].

[<sup>F473</sup>(3A) Nothing in item 1 or 1A of the Table shall prevent a vehicle being used on a road if—

- (a) a plating certificate in respect of the vehicle was in force immediately before the 1st January 1993; and
- (b) the laden weight of the vehicle does not exceed the weight shown in that certificate as being the weight not to be exceeded in Great Britain.]

(4) [<sup>F474</sup>In this Part of these Regulations and in Schedule 11—]

[<sup>F475</sup>“air spring” means a spring operated by means of air or other compressible fluid under pressure;

“air suspension” means a suspension system in which at least 75 per cent of the spring effect is caused by an air spring.]

“balanced agricultural trailer” means an agricultural trailer the whole of the weight of which is borne by its own wheels; and

“unbalanced agricultural trailer” means an agricultural trailer of which some, but not more than 35%, of the weight is borne by the drawing vehicle and the rest of the weight is borne by its own wheels.

[<sup>F476</sup>(5) For the purposes of this Part of these Regulations and Schedule 11, an axle shall be regarded as fitted with a road friendly suspension if its suspension is—

- (a) an air suspension, or
- (b) a suspension, not being an air suspension, which is regarded as being equivalent to an air suspension for the purposes of Community Directive 92/7.

(6) For the purposes of this Part of these Regulations and Schedule 11, an axle shall be regarded as fitted with twin tyres if it would be regarded as fitted with twin tyres for the purposes of Community Directive 92/7.]

#### Textual Amendments

**F467** Words in reg. 75 Table Item 1 substituted (1.1.1993) by [The Road Vehicles \(Construction and Use\) \(Amendment\) \(No. 4\) Regulations 1992 \(S.I. 1992/2016\)](#), regs. 1, **4(2)(a)(i)**

**Status:** Point in time view as at 31/03/2009.

**Status:** This revised version has been created from an electronic version contributed by Westlaw which was originally derived from the printed publication. **Read more** (See end of Document for details)**Changes to legislation:** There are currently no known outstanding effects for the The Road Vehicles (Construction and Use) Regulations 1986. (See end of Document for details)

- F468** Words in reg. 75 Table Item 1 added (1.1.1993) by The Road Vehicles (Construction and Use) (Amendment) (No. 4) Regulations 1992 (S.I. 1992/2016), regs. 1, **4(2)(a)(i)**
- F469** Words in reg. 75 Table Item 1 substituted (1.1.1993) by The Road Vehicles (Construction and Use) (Amendment) (No. 4) Regulations 1992 (S.I. 1992/2016), regs. 1, **4(2)(a)(ii)**
- F470** Reg. 75 Table Item 1A inserted (1.1.1993) by The Road Vehicles (Construction and Use) (Amendment) (No. 4) Regulations 1992 (S.I. 1992/2016), regs. 1, **4(2)(b)**
- F471** Reg. 75 Table Item 4 substituted (1.1.1993) by The Road Vehicles (Construction and Use) (Amendment) (No. 4) Regulations 1992 (S.I. 1992/2016), regs. 1, **4(2)(c)**
- F472** Word in reg. 75(3) substituted (1.1.1999) by The Road Vehicles (Construction and Use) (Amendment) (No. 7) Regulations 1998 (S.I. 1998/3112), regs. 1, **8**
- F473** Reg. 75(3A) inserted (1.1.1993) by The Road Vehicles (Construction and Use) (Amendment) (No. 4) Regulations 1992 (S.I. 1992/2016), regs. 1, **4(3)**
- F474** Words in reg. 75(4) substituted (1.1.1993) by The Road Vehicles (Construction and Use) (Amendment) (No. 4) Regulations 1992 (S.I. 1992/2016), regs. 1, **4(4)(a)**
- F475** Words in reg. 75(4) inserted (1.1.1993) by The Road Vehicles (Construction and Use) (Amendment) (No. 4) Regulations 1992 (S.I. 1992/2016), regs. 1, **4(4)(b)**
- F476** Reg. 75(5)(6) inserted (1.1.1993) by The Road Vehicles (Construction and Use) (Amendment) (No. 4) Regulations 1992 (S.I. 1992/2016), regs. 1, **4(5)**

**Commencement Information**

**I68** Reg. 75 in force at 11.8.1986, see **reg. 1**

**Maximum permitted laden weight of a vehicle and trailer, other than an articulated vehicle**

76.—(1) The total laden weight of a motor vehicle and the trailer or trailers (other than semi-trailers) drawn by it shall not, in a case specified in an item in column 2 of the Table, exceed the maximum permitted train weight specified in that item in column 3.

[<sup>F477</sup>(1A) This regulation is subject to Schedule 11A (exemptions relating to combined transport operations).]

[<sup>F478</sup>(2) In this regulation, the expressions “road friendly suspension”, “twin tyres” and “unbalanced agricultural trailer” shall be construed in accordance with regulation 75(4), (5) and (6).]

**TABLE**

(regulation 76(1))

<i>1</i> Item	<i>2</i> Vehicle Combination	<i>3</i> Maximum permitted train weight (kg)
<sup>F479</sup> 1	A wheeled trailer which is drawn by a wheeled motor tractor, heavy motor car (not being in any case an agricultural motor vehicle), where— (a) the combination has a total of 4 axles and is being used for international transport; and (b) the drawing vehicle is a vehicle which was first used on or after 1st April 1973 and complies with the relevant braking requirement	35,000]

**Status:** This revised version has been created from an electronic version contributed by Westlaw which was originally derived from the printed publication. **Read more** (See end of Document for details)**Changes to legislation:** There are currently no known outstanding effects for the The Road Vehicles (Construction and Use) Regulations 1986. (See end of Document for details)

1 Item	2 Vehicle Combination	3 Maximum permitted train weight (kg)
[ <sup>F479</sup> 1A	<p>A wheeled trailer which is drawn by a wheeled motor tractor, heavy motor car or motor car (not being in any case an agricultural motor vehicle), where the combination has a total of 4 axles and the following conditions are satisfied in relation to the drawing vehicle, namely—</p> <p>(a) it was first used on or after 1st April 1973;</p> <p>(b) it complies with the relevant braking requirement;</p> <p>(c) every driving axle not being a steering axle is fitted with twin tyres; and</p> <p>(d) every driving axle is fitted with road friendly suspension</p>	35,000]
[ <sup>F479</sup> 1AA	<p>A wheeled trailer which is drawn by a wheeled motor tractor, heavy motor car or motor car (not being in any case an agricultural motor vehicle), where the combination has a total of 5 or more axles and the following conditions are satisfied in relation to the drawing vehicle, namely—</p> <p>(a) it was first used on or after 1st April 1973;</p> <p>(b) it complies with the relevant braking requirement;</p> <p>(c) every driving axle not being a steering axle is fitted with twin tyres; and</p> <p>(d) either every driving axle is fitted with road friendly suspension or no axle has an axle weight exceeding 8,500kg</p>	38,000]
[ <sup>F479</sup> 1B	<p>A wheeled trailer, not being part of a combination described in items 1, 1A or 1AA which is drawn by a wheeled motor tractor, heavy motor car or motor car (not being in any case an agricultural motor vehicle), where—</p> <p>(a) the trailer is fitted with power-assisted brakes which can be operated by the driver of the drawing vehicle and are not rendered ineffective by the non-rotation of its engine; and</p>	32,520]

**Status:** Point in time view as at 31/03/2009.

**Status:** This revised version has been created from an electronic version contributed by Westlaw which was originally derived from the printed publication. **Read more** (See end of Document for details)**Changes to legislation:** There are currently no known outstanding effects for the The Road Vehicles (Construction and Use) Regulations 1986. (See end of Document for details)

1 Item	2 Vehicle Combination	3 Maximum permitted train weight (kg)
	(b) the drawing vehicle is equipped with a warning device so placed as to be readily visible to the driver of the vehicle and which is capable of indicating any impending failure of, or deficiency in, the vacuum or pressure system	
1C	A wheeled trailer which is of a description specified in item 8 in the Table of regulation 75 drawn by a wheeled motor tractor, heavy motor car or motor car (not being in any case an agricultural motor vehicle), the drawing vehicle being a vehicle which—  (a) was first used on or after 1st April 1973; and  (b) complies with the relevant braking requirement	29,500
2	A wheeled agricultural motor vehicle drawing a wheeled unbalanced agricultural trailer, if the distance between the rearmost axle of the trailer and the rearmost axle of the drawing vehicle does not exceed 2.9 m	20,000
3	A wheeled trailer or trailers drawn by a wheeled motor tractor, heavy motor car, motor car or agricultural motor vehicle, not being a combination of vehicles mentioned in items 1 [ <sup>F480</sup> , 1A, [ <sup>F481</sup> 1AA,] 1B, 1C] or 2	24,390
4	A track-laying trailer drawn by a motor tractor, heavy motor car or motor car, whether wheeled or track-laying and a wheeled trailer, drawn by a track-laying vehicle being a motor tractor, heavy motor car or motor car	22,360

#### Textual Amendments

**F477** Reg. 76(1A) inserted (24.3.1994) by The Road Vehicles (Construction and Use) (Amendment) (No. 2) Regulations 1994 (S.I. 1994/329), regs. 1, 7(2)

**F478** Reg. 76(2) substituted (1.1.1993) by The Road Vehicles (Construction and Use) (Amendment) (No. 4) Regulations 1992 (S.I. 1992/2016), regs. 1, 5(2)

**Status:** This revised version has been created from an electronic version contributed by Westlaw which was originally derived from the printed publication. **Read more** (See end of Document for details)**Changes to legislation:** There are currently no known outstanding effects for the The Road Vehicles (Construction and Use) Regulations 1986. (See end of Document for details)

- F479** Words in reg. 76 Table substituted (24.3.1994) by The Road Vehicles (Construction and Use) (Amendment) (No. 2) Regulations 1994 (S.I. 1994/329), regs. 1, **7(3)**
- F480** Words in reg. 76 Table inserted (1.1.1993) by The Road Vehicles (Construction and Use) (Amendment) (No. 4) Regulations 1992 (S.I. 1992/2016), regs. 1, **5(3)(b)**
- F481** Word in reg. 76 Table inserted (24.3.1994) by The Road Vehicles (Construction and Use) (Amendment) (No. 2) Regulations 1994 (S.I. 1994/329), regs. 1, **7(4)**

**Commencement Information**

**169** Reg. 76 in force at 11.8.1986, see **reg. 1**

**Maximum permitted laden weight of an articulated vehicle**

77.—(1) Except as provided in paragraph (2), the laden weight of an articulated vehicle of a class specified in an item in column 2 of the Table shall not exceed the weight specified in column 3 in that item.

**TABLE**

(regulation 77(1))

<i>1</i> Item	<i>2</i> Class of vehicle	<i>3</i> Maximum permitted laden weight (kg)
1	An articulated vehicle which complies with the relevant braking requirement.	Whichever is the lower of—  (a) the weight specified in column (3) of Part III of Schedule 11 in the item in which the spacing between the rearmost axles of the motor vehicle and the semi-trailer is specified in column (2), <sup>F482</sup> ...; and  (b) if the vehicle is of a description specified in an item in column (2) of Part IV of Schedule 11, the weight specified in column (3) of that item
2	An articulated vehicle which does not comply with the relevant braking requirement if the trailer has—	
	(a) less than 4 wheels	20,330
	(b) 4 wheels or more	24,390

(2) This regulation does not apply to an agricultural motor vehicle, an agricultural trailer or an agricultural trailed appliance.

[<sup>F483</sup>(2A) This regulation is subject to Schedule 11A (exemptions relating to combined transport operations).]

[<sup>F484</sup>(3) In Part IV of Schedule 11, “road friendly suspension” and “twin tyres” shall be construed in accordance with regulation 75(5) and (6).]

**Status:** Point in time view as at 31/03/2009.

**Status:** This revised version has been created from an electronic version contributed by Westlaw which was originally derived from the printed publication. **Read more** (See end of Document for details) **Changes to legislation:** There are currently no known outstanding effects for the The Road Vehicles (Construction and Use) Regulations 1986. (See end of Document for details)

### Textual Amendments

- F482** Words in [reg. 77](#) Table Item 1 omitted (24.3.1994) by virtue of [The Road Vehicles \(Construction and Use\) \(Amendment\) \(No. 2\) Regulations 1994](#) (S.I. 1994/329), regs. 1, **8(3)**
- F483** [Reg. 77\(2A\)](#) inserted (24.3.1994) by [The Road Vehicles \(Construction and Use\) \(Amendment\) \(No. 2\) Regulations 1994](#) (S.I. 1994/329), regs. 1, **8(2)**
- F484** [Reg. 77\(3\)](#) inserted (1.1.1993) by [The Road Vehicles \(Construction and Use\) \(Amendment\) \(No. 4\) Regulations 1992](#) (S.I. 1992/2016), regs. 1, **6**

### Commencement Information

- I70** [Reg. 77](#) in force at 11.8.1986, see [reg. 1](#)

## Maximum permitted wheel and axle weights

**78.**—(1) The weight transmitted to the road by one or more wheels of a vehicle as mentioned in an item in column 2 of the Table shall not exceed the maximum permitted weight specified in that item in column 3.

(2) The Parts of the Table have the following application—

- (a) Part I applies to wheeled heavy motor cars, motor cars and trailers which comply with the relevant braking requirement and to wheeled agricultural motor vehicles, agricultural trailers and agricultural trailed appliances; items 1(b) and 2 also apply to buses;
- (b) Part II applies to wheeled heavy motor cars, motor cars and trailers which do not fall in Part I;
- (c) Part III applies to wheeled locomotives; and
- (d) Part IV applies to track-laying vehicles.

#### PART I

(wheeled heavy motor cars, motor cars and trailers which comply with the relevant braking requirement and wheeled agricultural motor vehicles, agricultural trailers and agricultural trailed appliances; and, in respect of items 1(b) and 2, buses)

### TABLE

(regulation 78(1))

1 Item	2 Wheel criteria	3 Maximum permitted weight (kg)
1	Two wheels in line transversely each of which is fitted with a wide tyre or with two pneumatic tyres having the centres of their areas of contact with the road not less than 300 mm apart, measured at right angles to the longitudinal axis of the vehicle—	
	(a) if the wheels are on the sole driving axle of a motor vehicle [ <sup>F485</sup> not being a bus],	10,500
	(b) if the vehicle is a bus which has 2 axles and of which the weight	10,500

**Status:** This revised version has been created from an electronic version contributed by Westlaw which was originally derived from the printed publication. **Read more** (See end of Document for details)**Changes to legislation:** There are currently no known outstanding effects for the The Road Vehicles (Construction and Use) Regulations 1986. (See end of Document for details)

<i>1</i> Item	<i>2</i> Wheel criteria	<i>3</i> Maximum permitted weight (kg)
	transmitted to the road surface by its wheels is calculated in accordance with regulation 78(5),	
	(c) in any other case	10,170
2	Two wheels in line transversely otherwise than as mentioned in item 1	9,200
3	More than two wheels in line transversely—	
	(a) in the case of a vehicle manufactured before 1st May 1983 [ <sup>F486</sup> where] the wheels are on one axle of a group of <sup>F487</sup>	
	... closely spaced axles <sup>F488</sup>	
	...,	10,170
	(b) in the case of a vehicle manufactured on or after 1st May 1983,	10,170
	(c) in any other case	11,180
4	One wheel not transversely in line with any other wheel—	
	(a) if the wheel is fitted as described in item 1,	5,090
	(b) in any other case	4,600

## PART II

(wheeled heavy motor cars, motor cars and trailers not failing in Part I)

<i>1</i> Item	<i>2</i> Wheel criteria	<i>3</i> Maximum permitted weight (kg)
5	More than two wheels transmitting weight to a strip of the road surface on which the vehicle rests contained between two parallel lines at right angles to the longitudinal axis of the vehicle—	
	(a) less than 1.02 m apart,	11,180
	(b) 1.02 m or more apart but less than 1.22 m apart,	16,260
	(c) 1.22 m or more apart but less than 2.13 m apart	18,300
6	Two wheels in line transversely	9,200

**Status:** Point in time view as at 31/03/2009.

**Status:** This revised version has been created from an electronic version contributed by Westlaw which was originally derived from the printed publication. **Read more** (See end of Document for details)**Changes to legislation:** There are currently no known outstanding effects for the The Road Vehicles (Construction and Use) Regulations 1986. (See end of Document for details)

<i>1</i> Item	<i>2</i> Wheel criteria	<i>3</i> Maximum permitted weight (kg)
7	One wheel, where no other wheel is in the same line transversely.	4,600

PART III  
(wheeled locomotives)

<i>1</i> Item	<i>2</i> Wheel criteria	<i>3</i> Maximum permitted weight (kg)
8	Two wheels in line transversely (except in the case of a road roller, or a vehicle with not more than four wheels first used before 1st June 1955)	11,180
9	Any two wheels in the case of a wheeled locomotive having not more than four wheels first used before 1st June 1955 (not being a road roller or an agricultural motor vehicle which is not driven at more than 20 mph)	Three quarters of the total weight of the locomotive.

PART IV  
(track-laying vehicles)

<i>1</i> Item	<i>2</i> Wheel criteria	<i>3</i> Maximum permitted weight (kg)
10	The weight of a heavy motor car, motor car or trailer transmitted to any strip of the road surface on which the vehicle rests contained between two parallel lines 0.6 m apart at right angles to the longitudinal axis of the vehicle	10,170
11	Two wheels in line— (a) heavy motor cars or motor cars with 2 wheels, (b) heavy motor cars or motor cars with more than 2 wheels	8,130 7,630
12	One wheel, where no other wheel is in the same line transversely, on a heavy motor car or a motor car	4,070

(3) In the case of an articulated bus, or, subject to paragraph (4), of a bus first used before 1st April 1988, the laden weight, for the purposes of <sup>F489</sup>... regulation 75, and the weight transmitted to the road surface by wheels of the vehicle, for the purposes of items 1 and 2 of the Table in this



**Status:** This revised version has been created from an electronic version contributed by Westlaw which was originally derived from the printed publication. **Read more** (See end of Document for details)**Changes to legislation:** There are currently no known outstanding effects for the The Road Vehicles (Construction and Use) Regulations 1986. (See end of Document for details)

regulation, shall be calculated with reference to the vehicle when it is complete and fully equipped for service with—

- (a) a full supply of water, oil and fuel; and
- (b) weights of 63.5 kg for each person (including crew)—
  - (i) for whom a seat is provided in the position in which he may be seated; and
  - (ii) who may by or under any enactment be carried standing, the total of such weights being reasonably distributed in the space in which such persons may be carried, save that in the case of a bus (not being an articulated bus) only the number of such persons exceeding 8 shall be taken into account.

(4) The weights for the purposes referred to in paragraph (3) may, in the case of a bus to which that paragraph applies, be calculated in accordance with paragraph (5) instead of paragraph (3).

(5) In the case of a bus first used on or after 1st April 1988, the weights for the purposes referred to in paragraph (3) shall be calculated with reference to the vehicle when it is complete and fully equipped for service with—

- (a) a full supply of water, oil and fuel;
- (b) a weight of 65 kg for each person (including crew)—
  - (i) for whom a seat is provided, in the position in which he may be seated; and
  - (ii) who may by or under any enactment be carried standing, the total of such weights being reasonably distributed in the space in which such persons may be so carried, save that in the case of a bus (not being an articulated bus) only the number of such persons exceeding 4 shall be taken into account;
- (c) all luggage space within the vehicle but not within the passenger compartment loaded at the rate of 100 kg per m<sup>3</sup> or 10 kg per person mentioned in sub-paragraph (b) above, whichever is the less; and
- (d) any area of the roof of the vehicle constructed or adapted for the storage of luggage loaded with a uniformly distributed load at the rate of 75 kg per m<sup>2</sup>.

[<sup>F490</sup>(6) Regulation 75 shall not apply to a two axle bus if—

- (a) its laden weight as calculated in accordance with paragraph (5) does not exceed 17,000kg; and
- (b) the distance between the two axles is at least 3.0m.]

#### Textual Amendments

- F485** Words in [reg. 78 Table Item 1](#) substituted (1.4.1988) by [The Road Vehicles \(Construction and Use\) \(Amendment\) Regulations 1987 \(S.I. 1987/676\)](#), regs. 1(2), **13(1)**
- F486** Word in [reg. 78 Table Item 3\(a\)](#) substituted (1.1.1993) by [The Road Vehicles \(Construction and Use\) \(Amendment\) \(No. 4\) Regulations 1992 \(S.I. 1992/2016\)](#), regs. 1, **7(a)(i)**
- F487** Word in [reg. 78 Table Item 3\(a\)](#) omitted (1.1.1993) by virtue of [The Road Vehicles \(Construction and Use\) \(Amendment\) \(No. 4\) Regulations 1992 \(S.I. 1992/2016\)](#), regs. 1, **7(a)(ii)**
- F488** Words in [reg. 78 Table Item 3\(a\)](#) omitted (1.1.1993) by virtue of [The Road Vehicles \(Construction and Use\) \(Amendment\) \(No. 4\) Regulations 1992 \(S.I. 1992/2016\)](#), regs. 1, **7(a)(iii)**
- F489** Words in [reg. 78\(3\)](#) omitted (1.1.1993) by virtue of [The Road Vehicles \(Construction and Use\) \(Amendment\) \(No. 4\) Regulations 1992 \(S.I. 1992/2016\)](#), regs. 1, **7(b)**
- F490** [Reg. 78\(6\)](#) inserted (1.1.1993) by [The Road Vehicles \(Construction and Use\) \(Amendment\) \(No. 4\) Regulations 1992 \(S.I. 1992/2016\)](#), regs. 1, **7(c)**

**Status:** Point in time view as at 31/03/2009.

**Status:** This revised version has been created from an electronic version contributed by Westlaw which was originally derived from the printed publication. **Read more** (See end of Document for details)**Changes to legislation:** There are currently no known outstanding effects for the The Road Vehicles (Construction and Use) Regulations 1986. (See end of Document for details)

### Commencement Information

**I71** Reg. 78 in force at 11.8.1986, see [reg. 1](#)

## Maximum permitted weights for certain closely-spaced axles etc

**79.**—(1) This regulation applies to—

- (a) a wheeled motor vehicle which complies with the relevant braking requirement;
- (b) a wheeled trailer which is drawn by such a motor vehicle; and
- (c) an agricultural motor vehicle, an agricultural trailer and an agricultural trailed appliance.

<sup>[F491]</sup>(2) Save as provided in paragraph (5), where a vehicle to which this regulation applies is of a description specified in an item in column 2 of Part V of Schedule 11 and has two closely-spaced axles, the total weight transmitted to the road surface by all the wheels of those axles shall not exceed the maximum permitted weight specified in column 3 of that item.

(3) Save as provided in paragraph (5), where a vehicle to which this regulation applies is of a description specified in an item in column 2 of Part VI of Schedule 11 and has three closely-spaced axles, the total weight transmitted to the road surface by all the wheels of those axles shall not exceed the weight specified in column 3.

(4) Save as provided by paragraph (5), where a vehicle is fitted with four or more closely-spaced axles, the weight transmitted to the road surface by all the wheels of those axles shall not exceed 24,000kg.]

(5) Nothing in paragraphs (2), (3) or (4) of this regulation shall apply so as to prevent a vehicle first used before 1st June 1973 from being used on a road at a weight as respects those axles at which it could be used if it fell within item 5 in the Table in regulation 78 <sup>[F492]</sup>and nothing in those paragraphs shall prevent a vehicle being used on a road if—

- (a) a plating certificate in respect of the vehicle was in force immediately before the 1st January 1993; and
- (b) no axle has an axle weight exceeding the weight shown in that certificate as being the weight not to be exceeded in Great Britain for that axle.]

<sup>[F493]</sup>(6) In Parts V and VI of Schedule 11, “air-suspension” “road friendly suspension” and “twin tyres” shall be construed in accordance with regulation 75(4), (5) and (6).]

### Textual Amendments

**F491** Reg. 79(2)-(4) substituted (1.1.1993) by [The Road Vehicles \(Construction and Use\) \(Amendment\) \(No. 4\) Regulations 1992 \(S.I. 1992/2016\)](#), regs. 1, **8(2)**

**F492** Words in reg. 79(5) substituted (1.1.1993) by [The Road Vehicles \(Construction and Use\) \(Amendment\) \(No. 4\) Regulations 1992 \(S.I. 1992/2016\)](#), regs. 1, **8(3)**

**F493** Reg. 79(6) substituted for reg. 79(6)-(8) (1.1.1993) by [The Road Vehicles \(Construction and Use\) \(Amendment\) \(No. 4\) Regulations 1992 \(S.I. 1992/2016\)](#), regs. 1, **8(4)**

### Commencement Information

**I72** Reg. 79 in force at 11.8.1986, see [reg. 1](#)

## <sup>[F494]</sup>Saving for the Road Vehicles (Authorised Weight) Regulations 1998

**79A.** Nothing in regulations 75 to 79 shall be taken to prohibit the use of a vehicle in circumstances where the maximum authorised weight for the vehicle, for any vehicle combination

**Status:** This revised version has been created from an electronic version contributed by Westlaw which was originally derived from the printed publication. **Read more** (See end of Document for details)**Changes to legislation:** There are currently no known outstanding effects for the The Road Vehicles (Construction and Use) Regulations 1986. (See end of Document for details)

of which the vehicle forms part and for any axle of the vehicle, as determined in accordance with the Road Vehicles (Authorised Weight) Regulations 1998, is not exceeded.]

#### Textual Amendments

**F494** Reg. 79A inserted (1.1.1999) by [The Road Vehicles \(Construction and Use\) \(Amendment\) \(No. 7\) Regulations 1998 \(S.I. 1998/3112\)](#), regs. 1, **9**

#### Over-riding weight restrictions

**80.**—(1) Subject to [<sup>F495</sup>paragraphs (2), [<sup>F496</sup>(2B), (2C) and (4)]] , no person shall use, or cause or permit to be used, on a road a vehicle—

- (a) fitted with a plate in accordance with regulation 66, but for which no plating certificate has been issued, if any of the weights shown on the plate is exceeded;
- (b) for which a plating certificate has been issued, if any of the weights shown in column (2) of the plating certificate is exceeded; or
- (c) required by regulation 68 to be fitted with a plate, if the maximum gross weight referred to in paragraph (2)(c) of that regulation is exceeded.

(2) Where any two or more axles are fitted with a compensating arrangement in accordance with regulation 23 the sum of the weights shown for them in the plating certificate shall not be exceeded. In a case where a plating certificate has not been issued the sum of the weights referred to shall be that shown for the said axles in the plate fitted in accordance with regulation 66.

[<sup>F497</sup>(2A) Paragraph (1) shall not apply to a vehicle for which a plating certificate has been issued in the form set out in Schedule 10A or 10C where—

- (a) the vehicle is being used for international transport; and
- (b) none of the weights shown in column (3) of the plating certificate is exceeded.

(2B) Where both a train weight and a maximum train weight are shown in column (2) of a plating certificate issued for a motor vehicle, paragraph (1)(b) in so far as it relates to train weights shall not apply to the motor vehicle if—

- (a) the motor vehicle is a wheeled heavy motor car drawing a wheeled trailer and the requirements set out in Part II of Schedule 11A are for the time being fulfilled; or
- (b) the motor vehicle is comprised in an articulated vehicle and the requirements set out in Part III of Schedule 11A are for the time being fulfilled,

and the train weight of the motor vehicle does not exceed the maximum train weight shown in column (2) of the certificate.]

(3) Nothing in regulations 75 to 79 [<sup>F498</sup>or in the Road Vehicles (Authorised Weight) Regulations 1998] shall permit any such weight as is mentioned in the preceding provisions of this regulation to be exceeded and nothing in this regulation shall permit any weight prescribed by regulations 75 to 79 [<sup>F498</sup>or in the Road Vehicles (Authorised Weight) Regulations 1998] in relation to the vehicle in question to be exceeded.

[<sup>F499</sup>(4) Paragraph (1) shall not apply where a vehicle is used on a road before 1st January 2000 if—

- (a) the vehicle is fitted with a plate in accordance with regulation 66(1)(b) and the maximum gross weight and the maximum weight for any axle of the vehicle are not exceeded; or
- (b) there is in force a plating certificate for the vehicle that was issued before 1st January 1999 and the design weight of the vehicle is not exceeded; and

**Status:** Point in time view as at 31/03/2009.

**Status:** This revised version has been created from an electronic version contributed by Westlaw which was originally derived from the printed publication. **Read more** (See end of Document for details)**Changes to legislation:** There are currently no known outstanding effects for the The Road Vehicles (Construction and Use) Regulations 1986. (See end of Document for details)

- (c) in either case the maximum authorised weight for the vehicle, maximum authorised weight for a combination of which the vehicle forms part and maximum authorised weight for any axle of the vehicle, determined in accordance with the Road Vehicles (Authorised Weight) Regulations 1998, are not exceeded.]

#### Textual Amendments

- F495** Words in reg. 80(1) substituted (22.4.1997) by [The Road Vehicles \(Construction and Use\) \(Amendment\) \(No. 2\) Regulations 1997 \(S.I. 1997/1096\)](#), regs. 1, **3**
- F496** Words in reg. 80(1) substituted (1.1.1999) by [The Road Vehicles \(Construction and Use\) \(Amendment\) \(No. 7\) Regulations 1998 \(S.I. 1998/3112\)](#), regs. 1, **10(2)**
- F497** Reg. 80(2A)(2B) inserted (24.3.1994) by [The Road Vehicles \(Construction and Use\) \(Amendment\) \(No. 2\) Regulations 1994 \(S.I. 1994/329\)](#), regs. 1, **9(3)**
- F498** Words in reg. 80(3) inserted (1.1.1999) by [The Road Vehicles \(Construction and Use\) \(Amendment\) \(No. 7\) Regulations 1998 \(S.I. 1998/3112\)](#), regs. 1, **10(3)**
- F499** Reg. 80(4) inserted (1.1.1999) by [The Road Vehicles \(Construction and Use\) \(Amendment\) \(No. 7\) Regulations 1998 \(S.I. 1998/3112\)](#), regs. 1, **10(4)**

#### Commencement Information

- I73** Reg. 80 in force at 11.8.1986, see [reg. 1](#)

## B

### DIMENSIONS OF LADEN VEHICLES

*Restrictions on use of vehicles carrying wide or long loads or having fixed appliances or apparatus*

- 81.** For the purposes of this regulation, regulation 82 and Schedule 12—
- (a) “lateral projection”, in relation to a load carried by a vehicle, means that part of the load which extends beyond a side of the vehicle;
- (b) the width of any lateral projection shall be measured between longitudinal planes passing through the extreme projecting point of the vehicle on that side on which the projection lies and that part of the projection furthest from that point;
- (c) references to a special appliance or apparatus, in relation to a vehicle, are references to any crane or other special appliance or apparatus fitted to the vehicle which is a permanent or essentially permanent fixture;
- (d) “forward projection” and “rearward projection”—
- (i) in relation to a load carried in such a manner that its weight [<sup>F500</sup>is borne by] only one vehicle, mean respectively that part of the load which extends beyond the foremost point of the vehicle and that part which extends beyond the rearmost point of the vehicle;
- (ii) in relation to a load carried in such a manner that part of its weight [<sup>F501</sup>is borne by] more than one vehicle, mean respectively that part of the load which extends beyond the foremost point of the foremost vehicle by which the load is carried except where the context otherwise requires and that part of the load which extends beyond the rearmost point of the rearmost vehicle by which the load is carried; and
- (iii) in relation to any special appliance or apparatus, mean respectively that part of the appliance or apparatus which, if it were deemed to be a load carried by the vehicle,

would be a part of a load extending beyond the foremost point of the vehicle and that part which would be a part of a load extending beyond the rearmost point of the vehicle,

and references in regulation 82 and Schedule 12 to a forward projection or to a rearward projection in relation to a vehicle shall be construed accordingly;

- (e) the length of any forward projection or of any rearward projection shall be measured between transverse planes passing—
- (i) in the case of a forward projection, through the foremost point of the vehicle and that part of the projection furthest from that point; and
  - (ii) in the case of a rearward projection, through the rearmost point of the vehicle and that part of the projection furthest from that point;

In this and the foregoing sub-paragraph “vehicle” does not include any special appliance or apparatus or any part thereof which is a forward projection or a rearward projection;

- (f) references to the distance between vehicles, in relation to vehicles carrying a load, are references to the distance between the nearest points of any two adjacent vehicles by which the load is carried, measured when the longitudinal axis of each vehicle lies in the same vertical plane.

For the purposes of this sub-paragraph, in determining the nearest point of two vehicles any part of either vehicle designed primarily for use as a means of attaching the one vehicle to the other and any fitting designed for use in connection with any such part shall be disregarded;

- (g) references to a combination of vehicles, in relation to a motor vehicle which is drawing one or more trailers, are references to the motor vehicle and the trailer or trailers drawn thereby, including any other motor vehicle which is used for the purpose of assisting in the propulsion of the trailer or the trailers on the road;
- (h) the overall length of a combination of vehicles shall be taken as the distance between the foremost point of the drawing vehicle comprised in the combination and the rearmost point of the rearmost vehicle comprised therein, measured when the longitudinal axis of each vehicle comprised in the combination lies in the same vertical plane;
- (i) the extreme projecting point of a vehicle is the point from which the overall width of the vehicle is calculated in accordance with the definition of overall width contained in regulation 3(2);
- (j) without prejudice to sub-paragraph (e) the foremost or, as the case may be, the rearmost point of a vehicle is the foremost or rearmost point from which the overall length of the vehicle is calculated in accordance with the definition of overall length contained in regulation 3(2); and
- (k) an agricultural, horticultural or forestry implement rigidly but not permanently mounted on an agricultural motor vehicle, agricultural trailer or agricultural trailed appliance, whether or not part of its weight is supported by one or more of its own wheels, shall not be treated as a load, or special appliance, on that vehicle.

#### Textual Amendments

**F500** Words in reg. 81(d)(i) substituted (17.10.1991) by [The Road Vehicles \(Construction and Use\) \(Amendment\) \(No. 4\) Regulations 1991 \(S.I. 1991/2125\)](#), regs. 1, 7

**F501** Words in reg. 81(d)(ii) substituted (17.10.1991) by [The Road Vehicles \(Construction and Use\) \(Amendment\) \(No. 4\) Regulations 1991 \(S.I. 1991/2125\)](#), regs. 1, 7

**Status:** Point in time view as at 31/03/2009.

**Status:** This revised version has been created from an electronic version contributed by Westlaw which was originally derived from the printed publication. **Read more** (See end of Document for details)**Changes to legislation:** There are currently no known outstanding effects for the The Road Vehicles (Construction and Use) Regulations 1986. (See end of Document for details)

### Commencement Information

**I74** Reg. 81 in force at 11.8.1986, see **reg. 1**

**82.**—(1) No load shall be carried on a vehicle so that the overall width of the vehicle together with the width of any lateral projection or projections of its load exceeds 4.3m.

(2) Subject to the following provisions of this regulation, no load shall be carried on a vehicle so that—

- (a) the load has a lateral projection or projections on either side exceeding 305mm; or
- (b) the overall width of the vehicle and of any lateral projection or projections of its load exceeds 2.9m.

Provided that this paragraph does not apply to the carriage of—

- (i) loose agricultural produce not baled or crated; or
- (ii) an indivisible load if—
  - (A) it is not reasonably practicable to comply with this paragraph and the conditions specified in [F502 paragraphs 1 and 5] of Schedule 12 are complied with; and
  - (B) where the overall width of the vehicle together with the width of any lateral projection or projections of its load exceeds 3.5m, the conditions specified in paragraph 2 of Schedule 12 are complied with.

(3) Where a load is carried so that its weight rests on a vehicle or vehicles, the length specified in paragraph (5) shall not exceed 27.4m.

- [F503(4) A load shall not be carried so that its weight is borne by a vehicle or vehicles if either—
- (a) the length specified in paragraph (5) exceeds 18.65m; or
  - (b) the load is borne by a trailer or trailers and the length specified in paragraph (6) exceeds 25.9m,

unless the conditions specified in paragraphs 1 and 2 of Part I of Schedule 12 are complied with.]

- (5) The length referred to in paragraphs (3) and (4)(a) is—
- (a) where the [F504 weight of the load is borne by] a single vehicle, the overall length of the vehicle together with the length of any forward and rearward projection of the load;
  - (b) where the [F504 weight of the load is borne by] a motor vehicle and one trailer, whether or not forming an articulated vehicle, the overall length of the trailer together with the length of any projection of the load in front of the foremost point of the trailer and of any rearward projection of the load; and
  - (c) in any other case, the overall length of all the vehicles [F505 which bear the weight of the load], together with the length of any distance between them and of any forward or rearward projection of the load.

(6) The length referred to in paragraph (4)(b) is the overall length of the combination of vehicles, together with the length of any forward or rearward projection of the load.

(7) Subject to the following provisions of this regulation no person shall use, or cause or permit to be used, on a road a vehicle, not being a straddle carrier, carrying a load or fitted with a special appliance or apparatus if the load, appliance or apparatus has a forward projection of a length specified in an item in column 2 of the Table, or rearward projection of a length specified in an item in column 3, unless the conditions specified in that item in column 4 are complied with.

**Status:** This revised version has been created from an electronic version contributed by Westlaw which was originally derived from the printed publication. **Read more** (See end of Document for details)**Changes to legislation:** There are currently no known outstanding effects for the The Road Vehicles (Construction and Use) Regulations 1986. (See end of Document for details)

TABLE

(regulation 82(7))

1 Item	2 Length of forward projection	3 Length of rearward projection	4 Conditions to be complied with	
			(a)	(b)
			if the load consists of a racing boat propelled solely by oars.	in any other case
1	Exceeding 1 m but not exceeding 2 m	—	Para 4 of Schedule 12	—
2	Exceeding 2 m but not exceeding 3.05 m	—	Para 4 of Schedule 12	Paras 2 and 3 of Schedule 12
3	Exceeding 3.05 m	—	Paras 1 and 4 of Schedule 12	Paras 1, 2 and 3 of Schedule 12
4	—	Exceeding 1 m but not exceeding 2 m	Para 4 of Schedule 12	Para 4 of Schedule 12
5	—	Exceeding 2 m but not exceeding 3.05 m	Para 4 of Schedule 12	Para 3 of Schedule 12
6	—	Exceeding 3.05 m	Paras 1 and 4 of Schedule 12	Paras 1, 2 and 3 of Schedule 12

(8) Subject to the following provisions of this regulation, no person shall use, or cause or permit to be used, on a road a straddle carrier carrying a load if—

- (a) the load has a rearward projection exceeding 1 m unless the conditions specified in paragraph 4 of Schedule 12 are met;
- (b) the load has a forward projection exceeding 2 m or a rearward projection exceeding 3m; or
- (c) the overall length of the vehicle together with the length of any forward projection and of any rearward projection of its load exceeds 12.2m

Provided that—

- (i) sub-paragraph (a) does not apply to a vehicle being used in passing from one part of private premises to another part thereof or to other private premises in the immediate neighbourhood;
- (ii) sub-paragraphs (b) and (c) do not apply to a vehicle being used as in proviso (i) above if—
  - (A) the vehicle is not being driven at a speed exceeding 12 mph; and
  - (B) where the overall length of the vehicle together with the length of any forward projection and of any rearward projection of its load exceeds 12.2m, the conditions specified in paragraphs 1 and 2 of Schedule 12 are complied with.

(9) Where another vehicle is attached to that end of a vehicle from which a projection extends, then for the purposes of any requirement in this regulation to comply with paragraph 3 or 4 of Schedule 12, that projection shall be treated as a forward or rearward projection only if, and to the

**Status:** Point in time view as at 31/03/2009.

**Status:** This revised version has been created from an electronic version contributed by Westlaw which was originally derived from the printed publication. **Read more** (See end of Document for details)**Changes to legislation:** There are currently no known outstanding effects for the The Road Vehicles (Construction and Use) Regulations 1986. (See end of Document for details)

extent that it extends beyond the foremost point or, as the case may be, the rearmost point, of that other vehicle, measured when the longitudinal axis of each vehicle lies in the same vertical plane.

(10) In the case of a vehicle being used—

(a) for [<sup>F506</sup>fire brigade][<sup>F506</sup>relevant authority (as defined in section 6 of the Fire (Scotland) Act 2005 (asp 5))][<sup>F507</sup>or, in England or Wales, fire and rescue authority][<sup>F508</sup>or, in England, fire and rescue authority], ambulance or police purposes or for defence purposes (including civil defence purposes); or

(b) in connection with the removal of any obstruction to traffic,

if compliance with any provision of this regulation would hinder or be likely to hinder the use of the vehicle for the purpose for which it is being used, that provision does not apply to that vehicle while it is being so used.

(11) No person shall use, or cause or permit to be used, on a road an agricultural, horticultural or forestry implement rigidly, but not permanently, mounted on a wheeled agricultural motor vehicle, agricultural trailer, or agricultural trailed appliance, whether or not part of its weight is supported by one or more of its own wheels if—

(a) the overall width of the vehicle together with the lateral projection of the implement exceeds [<sup>F509</sup>2.55]m; or

(b) the implement projects more than 1m forwards or rearwards of the vehicle,

so however, that this restriction shall not apply in a case where—

(i) part of the weight of the implement is supported by one or more of its own wheels; and

(ii) the longitudinal axis of the greater part of the implement is capable of articulating in the horizontal plane in relation to the longitudinal axis of the rear portion of the vehicle.

### Textual Amendments

**F502** Words in reg. 82(2)(b)(ii)(A) substituted (17.10.1991) by [The Road Vehicles \(Construction and Use\) \(Amendment\) \(No. 4\) Regulations 1991 \(S.I. 1991/2125\)](#), regs. 1, **8(2)**

**F503** Reg. 82(4) substituted (17.10.1991) by [The Road Vehicles \(Construction and Use\) \(Amendment\) \(No. 4\) Regulations 1991 \(S.I. 1991/2125\)](#), regs. 1, **8(3)**

**F504** Words in reg. 82(5)(a)(b) substituted (17.10.1991) by [The Road Vehicles \(Construction and Use\) \(Amendment\) \(No. 4\) Regulations 1991 \(S.I. 1991/2125\)](#), regs. 1, **8(4)**

**F505** Words in reg. 82(5)(c) substituted (17.10.1991) by [The Road Vehicles \(Construction and Use\) \(Amendment\) \(No. 4\) Regulations 1991 \(S.I. 1991/2125\)](#), regs. 1, **8(4)**

**F506** Words in reg. 82(10)(a) substituted (S.) (2.8.2005) by [The Fire \(Scotland\) Act 2005 \(Consequential Modifications and Amendments\) \(No. 2\) Order 2005 \(S.S.I. 2005/344\)](#), art. 1, **sch. para. 5(4)(c)**; S.S.I. 2005/392, **art. 2**

**F507** Words in reg. 82(10)(a) inserted (W.) (25.10.2005) by [The Fire and Rescue Services Act 2004 \(Consequential Amendments\) \(Wales\) Order 2005 \(S.I. 2005/2929\)](#), arts. 1(1), **11(4)(c)**

**F508** Words in reg. 82(10)(a) inserted (E.) (30.12.2004) by [The Fire and Rescue Services Act 2004 \(Consequential Amendments\) \(England\) Order 2004 \(S.I. 2004/3168\)](#), arts. 1(1), **10(4)(c)**

**F509** Word in reg. 82(11)(a) substituted (1.1.1996) by [The Road Vehicles \(Construction and Use\) \(Amendment\) \(No. 6\) Regulations 1995 \(S.I. 1995/3051\)](#), regs. 1, **5**

### Commencement Information

**I75** Reg. 82 in force at 11.8.1986, see [reg. 1](#)



**Status:** This revised version has been created from an electronic version contributed by Westlaw which was originally derived from the printed publication. **Read more** (See end of Document for details) **Changes to legislation:** There are currently no known outstanding effects for the The Road Vehicles (Construction and Use) Regulations 1986. (See end of Document for details)

## C

## TRAILERS AND SIDECARS

**Number of trailers**

**83.**—(1) No person shall use, or cause or permit to be used, on a road a wheeled vehicle of a class specified in an item in column 2 of the Table drawing a trailer, subject to any exceptions which may be specified in that item in column 3.

**TABLE**

(regulation 83(1))

<i>1</i> Item	<i>2</i> Class of vehicles	<i>3</i> Exceptions
1	A straddle carrier	—
2	An invalid carriage	—
3	An articulated bus	—
4	A bus not being an articulated bus or a minibus	(a) 1 broken down bus where no person other than the driver is carried in either vehicle or  (b) [ <sup>F510</sup> 1 trailer]
5	A locomotive	3 trailers
6	A motor tractor	[ <sup>F511</sup> 1 trailer],  2 trailers if neither is laden
7	A heavy motor car or a motor car not described in item 1, 3 or 4	2 trailers if one of them is a towing implement and part of the other is secured to and either rests on or is suspended from that implement  1 trailer in any other case
8	An agricultural motor vehicle	(a) in respect of trailers other than agricultural trailers and agricultural trailed appliances, such trailers as are permitted under items 5, 6, or 7 above, as the case may be; or  (b) in respect of agricultural trailers and agricultural trailed appliances— (i) 2 unladen agricultural trailers, or (ii) 1 agricultural trailer and 1 agricultural trailed appliance, or (iii) 2 agricultural trailed appliances

(2) For the purposes of items 5, 6 and 7 of the Table—

- (a) an unladen articulated vehicle, when being drawn by another motor vehicle because it has broken down, shall be treated as a single trailer; and
- (b) a towed roller used for the purposes of agriculture, horticulture or forestry and consisting of several separate rollers shall be treated as one agricultural trailed appliance.

**Status:** Point in time view as at 31/03/2009.

**Status:** This revised version has been created from an electronic version contributed by Westlaw which was originally derived from the printed publication. **Read more** (See end of Document for details)**Changes to legislation:** There are currently no known outstanding effects for the The Road Vehicles (Construction and Use) Regulations 1986. (See end of Document for details)

(3) No track-laying motor vehicle which exceeds 8 m in overall length shall draw a trailer other than a broken down vehicle which is being drawn in consequence of the breakdown.

[<sup>F512</sup>(4) For the purpose of this regulation, the word “trailer” does not include a vehicle which is drawn by a steam powered vehicle and which is used solely for carrying water for the purpose of the drawing vehicle.]

#### Textual Amendments

- F510** Words in [reg. 83 Table](#) substituted (11.1.1990) by [The Road Vehicles \(Construction and Use\) \(Amendment\) \(No. 4\) Regulations 1989 \(S.I. 1989/2360\)](#), regs. 1, **4(a)**
- F511** Words in [reg. 83 Table](#) substituted (11.1.1990) by [The Road Vehicles \(Construction and Use\) \(Amendment\) \(No. 4\) Regulations 1989 \(S.I. 1989/2360\)](#), regs. 1, **4(b)**
- F512** [Reg. 83\(4\)](#) added (6.5.1987) by [The Road Vehicles \(Construction and Use\) \(Amendment\) Regulations 1987 \(S.I. 1987/676\)](#), regs. 1(2), **14**

#### Commencement Information

**I76** [Reg. 83](#) in force at 11.8.1986, see [reg. 1](#)

### Trailers drawn by motor cycles

**84.**—(1) Save as provided in paragraph (2), no person shall use, or cause or permit to be used, on a road a motor cycle—

- (a) drawing behind it more than one trailer;
- (b) drawing behind it any trailer carrying a passenger;
- (c) drawing behind it a trailer with an unladen weight exceeding 254 kg;
- (d) with not more than 2 wheels, without a sidecar, and with an engine capacity which does not exceed 125 cc, drawing behind it any trailer; or
- (e) with not more than 2 wheels, without a sidecar and with an engine capacity exceeding 125 cc, drawing behind it any trailer unless—
  - (i) the trailer has an overall width not exceeding 1 m;
  - (ii) the distance between the rear axle of the motor cycle and the rearmost part of the trailer does not exceed 2.5 m;
  - (iii) the motor cycle is clearly and indelibly marked in a conspicuous and readily accessible position with its kerbside weight;
  - (iv) the trailer is clearly and indelibly marked in a conspicuous and readily accessible position with its unladen weight; and
  - (v) the laden weight of the trailer does not exceed 150 kg or two thirds of the kerbside weight of the motor cycle, whichever is the less.

(2) The provisions of paragraph (1)(b), (d) and (e) do not apply if the trailer is a broken down motorcycle and one passenger is riding it.

#### Commencement Information

**I77** [Reg. 84](#) in force at 11.8.1986, see [reg. 1](#)

### Trailers drawn by agricultural motor vehicles

**85.**—(1) No person shall use, or cause or permit to be used, on a road a wheeled agricultural motor vehicle drawing one or more wheeled trailers if the weight of the drawing vehicle is less than a quarter of the weight of the trailer or trailers, unless the brakes fitted to each trailer in compliance with regulation 15 or 16 are operated directly by the service braking system fitted to the motor vehicle.

(2) No person shall use, or cause or permit to be used, on a road, any motor vehicle drawing an agricultural trailer of which—

- (a) more than 35% of the weight is borne by the drawing vehicle; or
- (b) the gross weight exceeds 14,230 kg, unless it is fitted with brakes as mentioned in paragraph (1).

(3) No person shall use, or cause or permit to be used, on a road an agricultural trailer manufactured on or after 1st December 1985 which is drawn by a motor vehicle first used on or after 1st June 1986 unless the brakes fitted to the trailer—

- (a) in accordance with regulation 15 can be applied progressively by the driver of the drawing vehicle, from his normal driving position and while keeping proper control of that vehicle, using a means of operation mounted on the drawing vehicle; or
- (b) automatically come into operation on the over-run of the trailer.

#### Commencement Information

**I78** Reg. 85 in force at 11.8.1986, see [reg. 1](#)

### Distance between motor vehicles and trailers

**86.**—(1) Where a trailer is attached to the vehicle immediately in front of it solely by means of a rope or chain, the distance between the trailer and that vehicle shall not in any case exceed 4.5 m, and shall not exceed 1.5 m unless the rope or chain is made clearly visible to any other person using the road within a reasonable distance from either side.

(2) For the purpose of determining the said distance any part of either vehicle designed primarily for use as a means of attaching the one vehicle to the other and any fitting designed for use in connection with any such part shall be disregarded.

#### Commencement Information

**I79** Reg. 86 in force at 11.8.1986, see [reg. 1](#)

### <sup>F513</sup>Use of secondary coupling on trailers

**86A.**—(1) No person shall use or cause or permit to be used on a road a motor vehicle drawing one trailer if the trailer—

- (a) is a trailer to which regulation 15 applies; and
- (b) is not fitted with a device which is designed to stop the trailer automatically in the event of the separation of the main coupling while the trailer is in motion,

unless the requirements of paragraph (2) are met in relation to the motor vehicle and trailer.

(2) The requirements of this paragraph, in relation to a motor vehicle drawing a trailer, are that a secondary coupling is attached to the motor vehicle and trailer in such a way that, in the event of the separation of the main coupling while the trailer is in motion,—

**Status:** Point in time view as at 31/03/2009.

**Status:** This revised version has been created from an electronic version contributed by Westlaw which was originally derived from the printed publication. **Read more** (See end of Document for details)**Changes to legislation:** There are currently no known outstanding effects for the The Road Vehicles (Construction and Use) Regulations 1986. (See end of Document for details)

- (a) the drawbar of the trailer would be prevented from touching the ground; and
  - (b) there would be some residual steering of the trailer.
- (3) No person shall use or cause or permit to be used on a road a motor vehicle drawing one trailer if—
- (a) the trailer is a trailer to which regulation 15 applies;
  - (b) the trailer is fitted with a device which is designed to stop the trailer automatically in the event of the separation of the main coupling while the trailer is in motion;
  - (c) the operation of the device in those circumstances depends upon a secondary coupling linking the device to the motor vehicle; and
  - (d) the trailer is not also fitted with a device which is designed to stop the trailer automatically in those circumstances in the absence of such a secondary coupling,
- unless the requirements of paragraph (4) are met in relation to the motor vehicle and trailer.
- (4) The requirements of this paragraph, in relation to a motor vehicle drawing a trailer, are that the secondary coupling is attached to the motor vehicle and trailer in such a way that, in the event of the separation of the main coupling while the trailer is in motion, the device of the kind referred to in paragraph (3)(b) and (c) fitted to the trailer would stop the trailer.
- (5) This regulation is without prejudice to any other provision in these Regulations.]

#### Textual Amendments

**F513** Reg. 86A inserted (1.4.1995) by [The Road Vehicles \(Construction and Use\) \(Amendment\) Regulations 1995 \(S.I. 1995/551\)](#), regs. 1, 8

#### [<sup>F514</sup>Use of mechanical coupling devices

**86B.**—(1) This regulation applies to every light passenger vehicle first used on or after 1st August 1998 in respect of which an EC certificate of conformity has effect.

(2) No person shall use or cause or permit to be used on a road any vehicle to which this regulation applies unless any mechanical coupling device which is attached to it complies with the relevant technical and installation requirements of Annexes I, V, VI and VII of Community Directive 94/20 and is marked in accordance with sub-paragraphs 3.3.4 to 3.3.5 of Annex I to that Directive.

(3) For the purposes of this regulation, in a case where a vehicle is drawing a trailer a mechanical coupling device shall not be regarded as being attached to that vehicle if it forms part of the trailer.

(4) In this regulation “mechanical coupling device” shall be construed in accordance with paragraph 2.1 of Annex I to Community Directive 94/20.]

#### Textual Amendments

**F514** Reg. 86B inserted (1.8.1998) by [The Road Vehicles \(Construction and Use\) \(Amendment\) \(No. 4\) Regulations 1998 \(S.I. 1998/1281\)](#), regs. 1, 3

#### Unbraked trailers

**87.**—(1) Save as provided in paragraph (2), no person shall use, or cause or permit to be used, on a road an unbraked wheeled trailer if—

- (a) its laden weight exceeds its maximum gross weight; or

**Status:** This revised version has been created from an electronic version contributed by Westlaw which was originally derived from the printed publication. **Read more** (See end of Document for details)**Changes to legislation:** There are currently no known outstanding effects for the The Road Vehicles (Construction and Use) Regulations 1986. (See end of Document for details)

- (b) it is drawn by a vehicle of which the kerbside weight is less than twice the sum of the unladen weight of the trailer and the weight of any load which the trailer is carrying.
- (2) This regulation does not apply to—
  - (a) an agricultural trailer; or
  - (b) a trailer mentioned in [<sup>F515</sup>paragraph (b), (bb), (bc), (c), (d), (e), (f) or (g) of regulation 16(3)].

**Textual Amendments**

**F515** Words in [reg. 87\(2\)\(b\)](#) substituted (1.1.1997) by [The Road Vehicles \(Construction and Use\) \(Amendment\) \(No. 7\) Regulations 1996 \(S.I. 1996/3033\)](#), regs. 1, **8**

**Commencement Information**

**I80** [Reg. 87](#) in force at 11.8.1986, see [reg. 1](#)

**Use of bridging plates between motor vehicle and trailer**

<sup>F516</sup>**88.** . . . . .

**Textual Amendments**

**F516** [Reg. 88](#) revoked (1.11.1998) by [The Road Vehicles \(Construction and Use\) \(Amendment\) \(No. 6\) Regulations 1998 \(S.I. 1998/2429\)](#), regs. 1, **7**

**Leaving trailers at rest**

**89.** No person in charge of a motor vehicle, or trailer drawn thereby, shall cause or permit such trailer to stand on a road when detached from the drawing vehicle unless one at least of the wheels of the trailer is (or, in the case of a track-laying trailer, its tracks are) prevented from revolving by the setting of [<sup>F517</sup>a parking brake] or the use of a chain, chock or other efficient device.

**Textual Amendments**

**F517** Words in [reg. 89](#) substituted (1.1.1997) by [The Road Vehicles \(Construction and Use\) \(Amendment\) \(No. 7\) Regulations 1996 \(S.I. 1996/3033\)](#), regs. 1, **9**

**Commencement Information**

**I81** [Reg. 89](#) in force at 11.8.1986, see [reg. 1](#)

**Passengers in trailers**

**90.**—(1) Save as provided in paragraph (2), no person shall use, or cause or permit to be used, on a road any trailer for the carriage of passengers for hire or reward.

(2) The provisions of paragraph (1) do not apply in respect of a wheeled trailer which is, or is carrying, a broken down motor vehicle if—

- (a) the trailer is drawn at a speed not exceeding 30 mph; and
- (b) where the trailer is, or is carrying, a broken down bus, it is attached to the drawing vehicle by a rigid draw bar.

**Status:** Point in time view as at 31/03/2009.

**Status:** This revised version has been created from an electronic version contributed by Westlaw which was originally derived from the printed publication. **Read more** (See end of Document for details)**Changes to legislation:** There are currently no known outstanding effects for the The Road Vehicles (Construction and Use) Regulations 1986. (See end of Document for details)

- (3) Save as provided in paragraph (4), no person shall use, or cause or permit to be used, on a road a wheeled trailer in which any person is carried and which is a living van having either—
- (a) less than 4 wheels; or
  - (b) 4 wheels consisting of two close-coupled wheels on each side.
- (4) The provisions of paragraph (3) do not apply in respect of a trailer which is being tested by—
- (a) its manufacturer;
  - (b) a person by whom it has been, or is being, repaired; or
  - (c) a distributor of, or dealer in, trailers.

#### Commencement Information

**182** Reg. 90 in force at 11.8.1986, see [reg. 1](#)

#### Attendants on trailers and certain other vehicles

**91.**—(1) The requirements of section 34 of the 1972 Act with regard to the employment of drivers and attendants shall not apply in respect of the following vehicles—

- (a) an articulated vehicle;
- (b) an agricultural motor vehicle which is drawing an agricultural trailer or an agricultural trailed appliance;
- (c) a trailer with not more than two wheels drawn by a motor car or a motor cycle or a four-wheeled trailer having two close-coupled wheels on each side drawn by a motor car;
- (d) a motor tractor drawing any—
  - (i) closed trailer specially constructed and used for the conveyance of meat between docks and railway stations or between wholesale markets and docks or railway stations;
  - (ii) machine or implement used for the purpose of the maintenance, repair or cleansing of roads; or
  - (iii) refuse vehicle;
- (e) a works truck drawing any works trailer where the unladen weight of each vehicle does not exceed 1525 kg;
- (f) a motor vehicle drawing a trailer which has no brakes other than a parking brake and brakes which automatically come into operation on the overrun of the trailer;
- (g) a road roller;
- (h) a motor vehicle belonging to the Secretary of State for Defence and being used for naval, military or air force purposes drawing a trailer fitted with brakes which can be applied by the driver of the drawing vehicle;
- (i) a motor vehicle drawing a broken down vehicle, whether or not in consequence of a breakdown, in such a manner that the broken down vehicle cannot be steered by its own steering gear;
- (j) a motor vehicle drawing another vehicle in the exercise of a statutory power of removal in such a manner that the vehicle being so drawn cannot be steered by its own steering gear;
- (k) a motor vehicle which is drawing a towing implement not attached to any other vehicle; or
- (l) a motor vehicle drawing a trailer or trailers where every such trailer is fitted with power-assisted or power-operated brakes which can be operated by the driver of the drawing

**Status:** This revised version has been created from an electronic version contributed by Westlaw which was originally derived from the printed publication. **Read more** (See end of Document for details)**Changes to legislation:** There are currently no known outstanding effects for the The Road Vehicles (Construction and Use) Regulations 1986. (See end of Document for details)

vehicle and are not rendered ineffective by the non-rotation of the engine of the drawing vehicle—

- (i) where one such trailer is drawn; or
- (ii) where two or more such trailers are drawn, if one attendant is carried on either the drawing vehicle or a trailer for the purpose of attending to the trailers.

(2) The requirements of the said section 34 with regard to the employment of persons to drive or attend a locomotive whilst being driven on a highway shall not apply in the case of a locomotive propelled by the combustion of liquid fuel or by electrical power, whether or not the locomotive is drawing a trailer or trailers.

(3) The provisions of this regulation shall not be treated as prejudicing the operation of any provision of regulation 82 in so far as it provides, in relation to the use of a vehicle on a road, for compliance with the conditions specified in paragraph 2 of Schedule 12 (which relates to the employment of persons in attending to vehicles and their load).

**Commencement Information**

**I83** [Reg. 91](#) in force at 11.8.1986, see [reg. 1](#)

**Attachment of sidecars**

**92.** Every sidecar fitted to a motor cycle shall be so attached that the wheel thereof is not wholly outside the space between transverse planes passing through the extreme projecting points at the front and at the rear of the motor cycle.

**Commencement Information**

**I84** [Reg. 92](#) in force at 11.8.1986, see [reg. 1](#)

**Use of sidecars**

**93.** No person shall use or cause or permit to be used on a road any two-wheeled motor cycle registered on or after 1st August 1981, not being a motor cycle brought temporarily into Great Britain by a person resident abroad, if there is a sidecar attached to the right (or off) side of the motor cycle.

**Commencement Information**

**I85** [Reg. 93](#) in force at 11.8.1986, see [reg. 1](#)

[<sup>F518</sup>CA

USE OF MOTOR VEHICLES FOR THE CARRIAGE  
OR HAULAGE OF DANGEROUS GOODS

**Textual Amendments**

**F518** [Reg. 93A](#) and heading inserted (3.1.1997) by [The Road Vehicles \(Construction and Use\) \(Amendment\) \(No. 8\) Regulations 1996 \(S.I. 1996/3133\)](#), [regs. 1, 4](#), [Sch.](#)

**Status:** Point in time view as at 31/03/2009.

**Status:** This revised version has been created from an electronic version contributed by Westlaw which was originally derived from the printed publication. **Read more** (See end of Document for details)**Changes to legislation:** There are currently no known outstanding effects for the The Road Vehicles (Construction and Use) Regulations 1986. (See end of Document for details)

### **Additional braking requirements for motor vehicles carrying or hauling dangerous goods**

**93A.**—(1) Subject to paragraph (5), no person shall use or cause or permit to be used a motor vehicle for the carriage or haulage of dangerous goods on a road if it is a vehicle within the meaning of the Framework Directive and—

- (a) its maximum gross weight exceeds 16,000 kg; or
- (b) it is drawing a trailer which has a maximum total design axle weight exceeding 10,000 kg,

unless the vehicle meets the requirements of paragraph (2).

(2) Subject to paragraph (6), in order for a motor vehicle to meet the requirements of this paragraph—

- (a) it must not be drawing more than one trailer;
- (b) without prejudice to regulation 15, it must be fitted with an anti-lock braking system that meets the requirements of paragraph (1) of marginal 220 521 of Appendix B.2 to Annex B to the ADR;
- (c) it must be fitted with an endurance braking system (which may consist of one device or a combination of several devices) that meets the requirements of sub-paragraphs (a) to (d) of paragraph (2) of marginal 220 522 of Appendix B.2 to Annex B to the ADR;
- (d) if it is not drawing a trailer, it must meet the requirements of the 4th, 5th, 6th and 7th sub-paragraphs of paragraph (2) of marginal 10 221 of Annex B to the ADR;
- (e) without prejudice to regulation 15, if it is drawing a trailer with a maximum total design axle weight exceeding 10,000 kg—
  - (i) the trailer must be fitted with an anti-lock braking system that meets the requirements of paragraph (2) of marginal 220 521 of Appendix B.2 to Annex B to the ADR, and
  - (ii) the electrical connections between the motor vehicle and the trailer must meet the requirements of paragraph (3) of marginal 220 521 of Appendix B.2 to Annex B to the ADR;
- (f) if it is drawing a trailer, the combination of vehicles must meet the requirements of the 4th, 5th, 6th and 7th sub-paragraphs of paragraph (2) of marginal 10 221 of Annex B to the ADR;
- (g) if it is drawing a trailer fitted with an endurance braking system, the trailer must meet the requirements of paragraph (3) of marginal 220 522 of Appendix B.2 to Annex B to the ADR; and
- (h) if it is drawing a trailer, the requirements of either paragraph (3) or (4) must be met.

(3) The requirements of this paragraph are that the motor vehicle meets the requirements of paragraph (2)(e) of marginal 220 522 of Appendix B.2 to Annex B to the ADR.

(4) The requirements of this paragraph are that the motor vehicle—

- (a) does not contravene the restriction mentioned in sub-paragraph (f) of paragraph (2) of marginal 220 522 of Appendix B.2 to Annex B to the ADR; and
- (b) meets the requirements of the second sentence of that sub-paragraph in relation to the trailer.

(5) Paragraph (1) does not apply to a motor vehicle manufactured before 1st January 1997.

(6) Sub-paragraph (e) of paragraph (2) does not apply to a trailer manufactured before 1st January 1997.

(7) For the purposes of this regulation, Annex B to the ADR (including the Appendices to that Annex) shall have effect as if—



**Status:** This revised version has been created from an electronic version contributed by Westlaw which was originally derived from the printed publication. **Read more** (See end of Document for details)**Changes to legislation:** There are currently no known outstanding effects for the The Road Vehicles (Construction and Use) Regulations 1986. (See end of Document for details)

- (a) references to ECE Regulation 13 (however expressed) were references to ECE Regulation 13.06 or 13.07;
  - (b) references to Directive [71/320/EEC](#) were references to Community Directive 91/422;
  - (c) references to the corresponding EEC Directive, in relation to Annex 5 to ECE Regulation 13, were references to paragraph 1.5 of Annex II to Community Directive 91/422.
- (8) Subject to paragraph (9), a reference in this regulation to dangerous goods is a reference to a load comprising explosives of such type and in such quantity that it could not be carried by road in a single transport unit of Type I and II without there being a contravention of the restrictions set out in marginal 11 401 of Annex B to the ADR as read with marginal 11 402 of that Annex.
- (9) For the purposes of paragraph (8)—
- (a) marginal 11 402 of Annex B to the ADR shall have effect with the omission of the words “in conformity with the prohibitions of mixed loading contained in 11 403”; and
  - (b) “transport unit of Type I or II” means a transport unit of Type I or a transport unit of Type II as defined in marginal 11 204 of that Annex.
- (10) In this regulation, “ADR” means the 1995 edition of the “European Agreement concerning the International Carriage of Dangerous Goods by Road (ADR)” produced by the Department of Transport and published by Her Majesty’s Stationery Office (ISBN 0-11-551265-9).]

## D

### USE OF GAS PROPULSION SYSTEMS AND GAS-FIRED APPLIANCES

#### Use of gas propulsion systems

- 94.**—(1) No person shall use, or cause or permit to be used, on a road a vehicle with a gas propulsion system unless the whole of such system is in a safe condition.
- (2) No person shall use, or cause or permit to be used, in any gas supply system for the propulsion of a vehicle when the vehicle is on a road any fuel except liquefied petroleum gas.
- (3) No person shall use, or cause or permit to be used, on a road a vehicle which is propelled by gas unless the gas container in which such fuel is stored is on the motor vehicle, and not on any trailer, and in the case of an articulated vehicle on the portion of the vehicle to which the engine is fitted.
- (4) In this regulation and in regulation 95 “liquefied petroleum gas” means—
- (a) butane gas in any phase which meets the requirements contained in the specification of commercial butane and propane issued by the British Standards Institution under the number BS4250: 1975 and published on 29th August 1975; or
  - (b) propane gas in any phase which meets the requirements contained in the said specification; or
  - (c) any mixture of such butane gas and such propane gas.

#### Commencement Information

**186** [Reg. 94](#) in force at 11.8.1986, see [reg. 1](#)

#### Use of gas-fired appliances—general

- 95.**—(1) No person shall use, or cause or permit to be used, in or on a vehicle on a road any gas-fired appliance unless the whole of such appliance and the gas system attached thereto is in an efficient and safe condition.

**Status:** Point in time view as at 31/03/2009.

**Status:** This revised version has been created from an electronic version contributed by Westlaw which was originally derived from the printed publication. **Read more** (See end of Document for details)**Changes to legislation:** There are currently no known outstanding effects for the The Road Vehicles (Construction and Use) Regulations 1986. (See end of Document for details)

(2) No person shall use, or cause or permit to be used, in any gas-fired appliance in or on a vehicle on a road any fuel except liquefied petroleum gas as defined in regulation 94(4).

(3) No person shall use, or cause or permit to be used, in or on a vehicle on a road any gas-fired appliance unless the vehicle is so ventilated that—

- (a) an ample supply of air is available for the operation of the appliance;
- (b) the use of the appliance does not adversely affect the health or comfort of any person using the vehicle; and
- (c) any unburnt gas is safely disposed of to the outside of the vehicle.

(4) No person shall use, or cause or permit to be used, on a road a vehicle in or on which there is—

- (a) one gas-fired appliance unless the gas supply for such appliance is shut off at the point where it leaves the container of containers at all times when the appliance is not in use;
- (b) more than one gas-fired appliance each of which has the same supply of gas unless the gas supply for such appliances is shut off at the point where it leaves the container or containers at all times when none of such appliances is in use; or
- (c) more than one gas-fired appliance each of which does not have the same supply of gas unless each gas supply for such appliances is shut off at the point where it leaves the container or containers at all times when none of such appliances which it supplies is in use.

#### Commencement Information

**I87** Reg. 95 in force at 11.8.1986, see [reg. 1](#)

#### Use of gas-fired appliances when a vehicle is in motion

**96.**—(1) Subject to paragraph (2), this regulation applies to every motor vehicle and trailer.

(2) Paragraphs (3) and (4) do not apply to a vehicle constructed or adapted for the conveyance of goods under controlled temperatures.

(3) No person shall use, or cause or permit to be used, in any vehicle to which this paragraph applies, while the vehicle is in motion on a road, any gas-fired appliance except—

- (a) a gas-fired appliance which is fitted to engineering plant while the plant is being used for the purposes of the engineering operations for which it was designed;
- (b) a gas-fired appliance which is permanently attached to a bus, provided that any appliance for heating or cooling the interior of the bus for the comfort of the driver and any passengers does not expose a naked flame on the outside of the appliance; or
- (c) in any other vehicle, a refrigerating appliance or an appliance which does not expose a naked flame on the outside of the appliance and which is permanently attached to the vehicle and designed for the purpose of heating any part of the interior of the vehicle for the comfort of the driver and any passengers.

(4) No person shall use, or cause or permit to be used, in any vehicle to which this paragraph applies, while the vehicle is in motion on a road, any gas-fired appliance to which—

- (a) sub-paragraph (3)(a) refers, unless the appliance complies with the requirements specified in paragraphs 12 and 13 of Schedule 5 and the gas system to which it is attached complies with the requirements specified in paragraphs 2 to 9 and 15 of Schedule 5; or
- (b) sub-paragraph (3)(b) refers, unless the appliance complies with the requirements specified in paragraphs 12, 13 and 14 of Schedule 5 and the gas system to which it is attached complies with the requirements specified in paragraphs 2 to 9, 11 and 15 of Schedule 5; or

**Status:** This revised version has been created from an electronic version contributed by Westlaw which was originally derived from the printed publication. **Read more** (See end of Document for details)**Changes to legislation:** There are currently no known outstanding effects for the The Road Vehicles (Construction and Use) Regulations 1986. (See end of Document for details)

- (c) sub-paragraph (3)(c) refers, unless the appliance complies—
- (i) if it is fitted to a motor vehicle, with the requirements specified in paragraphs 12, 13 and 14 of Schedule 5; and
  - (ii) in any other case, with the requirements specified in paragraphs 12 and 13 of Schedule 5;
- and the gas system to which the appliance is attached complies with the requirements specified in paragraphs 2 to 9 and 15 of Schedule 5.

(5) No person shall use, or cause or permit to be used, in a vehicle to which this regulation applies which is in motion on a road any gas-fired appliance unless it is fitted with a valve which stops the supply of gas to the appliance if the appliance fails to perform its function and causes gas to be emitted.

#### Commencement Information

**188** Reg. 96 in force at 11.8.1986, see [reg. 1](#)

## E

### CONTROL OF NOISE

#### Avoidance of excessive noise

**97.** No motor vehicle shall be used on a road in such manner as to cause any excessive noise which could have been avoided by the exercise of reasonable care on the part of the driver.

#### Commencement Information

**189** Reg. 97 in force at 11.8.1986, see [reg. 1](#)

#### Stopping of engine when stationary

**98.**—(1) Save as provided in paragraph (2), the driver of a vehicle shall, when the vehicle is stationary, stop the action of any machinery attached to or forming part of the vehicle so far as may be necessary for the prevention of noise [<sup>F519</sup>or of exhaust emissions].

- (2) The provisions of paragraph (1) do not apply—
- (a) when the vehicle is stationary owing to the necessities of traffic;
  - (b) so as to prevent the examination or working of the machinery where the examination is necessitated by any failure or derangement of the machinery or where the machinery is required to be worked for a purpose other than driving the vehicle; or
  - (c) in respect of a vehicle propelled by gas produced in plant carried on the vehicle, to such plant.

#### Textual Amendments

**F519** Words in [reg. 98\(1\)](#) inserted (2.2.1998) by [The Road Vehicles \(Construction and Use\) \(Amendment\) Regulations 1998 \(S.I. 1998/1\)](#), [regs. 1, 3](#)

#### Commencement Information

**190** Reg. 98 in force at 11.8.1986, see [reg. 1](#)

**Status:** Point in time view as at 31/03/2009.

**Status:** This revised version has been created from an electronic version contributed by Westlaw which was originally derived from the printed publication. **Read more** (See end of Document for details)**Changes to legislation:** There are currently no known outstanding effects for the The Road Vehicles (Construction and Use) Regulations 1986. (See end of Document for details)

## Use of audible warning instruments

**99.**—(1) Subject to the following paragraphs, no person shall sound, or cause or permit to be sounded, any horn, gong, bell or siren fitted to or carried on a vehicle which is—

- (a) stationary on a road, at any time, other than at times of danger due to another moving vehicle on or near the road; or
- (b) in motion on a restricted road, between 23.30 hours and 07.00 hours in the following morning.

(2) The provisions of paragraph (1)(a) do not apply in respect of the sounding of a reversing alarm when the vehicle to which it is fitted is about to move backwards and its engine is running.

(3) No person shall sound, or cause or permit to be sounded, on a road any reversing alarm fitted to a vehicle—

- (a) unless the vehicle is a goods vehicle which has a maximum gross weight not less than 2000 kg, a bus, engineering plant, [<sup>F520</sup>a refuse vehicle,] or a works truck; or
- (b) if the sound of the alarm is likely to be confused with a sound emitted in the operation of a pedestrian crossing established, or having effect as if established, under Part III of the 1984 Act.

(4) Subject to the provisions of the following paragraphs, no person shall sound, or cause or permit to be sounded a gong, bell, siren or two-tone horn, fitted to or otherwise carried on a vehicle (whether it is stationary or not).

(5) Nothing in paragraph (1) or (4) shall prevent the sounding of—

- (a) an instrument or apparatus fitted to, or otherwise carried on, a vehicle at a time when the vehicle is being used for one of the purposes specified in regulation 37(5) and it is necessary or desirable to do so either to indicate to other road users the urgency of the purposes for which the vehicle is being used, or to warn other road users of the presence of the vehicle on the road; or
- (b) a horn (not being a two-tone horn), bell, gong or siren—
  - (i) to raise alarm as to the theft or attempted theft of the vehicle or its contents; or
  - (ii) in the case of a bus, to summon help for the driver, the conductor or an inspector.

(6) Subject to the provisions of section 62 of the Control of Pollution Act 1974 and notwithstanding the provisions of paragraphs (1) and (4) above, a person may, between 12.00 hours and 19.00 hours, sound or cause or permit to be sounded an instrument or apparatus, other than a two-tone horn, fitted to or otherwise carried on a vehicle, being an instrument or apparatus designed to emit a sound for the purpose of informing members of the public that the vehicle is conveying goods for sale, if, when the apparatus or instrument is sounded, it is sounded only for that purpose.

(7) For the purposes of this regulation the expressions which are referred to in regulation 37(10) have the meanings there given to them and the expression “restricted road” in paragraph (1) means a road which is a restricted road for the purpose of section 81 of the 1984 Act.

### Textual Amendments

**F520** Words in reg. 99(3)(a) inserted (6.5.1987) by [The Road Vehicles \(Construction and Use\) \(Amendment\) Regulations 1987 \(S.I. 1987/676\)](#), regs. 1(2), **15(5)**

### Commencement Information

**I91** [Reg. 99](#) in force at 11.8.1986, see [reg. 1](#)

## F

### AVOIDANCE OF DANGER

#### Maintenance and use of vehicle so as not to be a danger, etc

**100.**—(1) A motor vehicle, every trailer drawn thereby and all parts and accessories of such vehicle and trailer shall at all times be in such condition, and the number of passengers carried by such vehicle or trailer, the manner in which any passengers are carried in or on such vehicle or trailer, and the weight, distribution, packing and adjustment of the load of such vehicle or trailer shall at all times be such, that no danger is caused or is likely to be caused to any person in or on the vehicle or trailer or on a road.

Provided that the provisions of this regulation with regard to the number of passengers carried shall not apply to a vehicle to which the Public Service Vehicles (Carrying Capacity) Regulations 1984 apply.

(2) The load carried by a motor vehicle or trailer shall at all times be so secured, if necessary by physical restraint other than its own weight, and be in such a position, that neither danger nor nuisance is likely to be caused to any person or property by reason of the load or any part thereof falling or being blown from the vehicle or by reason of any other movement of the load or any part thereof in relation to the vehicle.

(3) No motor vehicle or trailer shall be used for any purpose for which it is so unsuitable as to cause or be likely to cause danger or nuisance to any person in or on the vehicle or trailer or on a road.

#### Commencement Information

**192** Reg. 100 in force at 11.8.1986, see [reg. 1](#)

**[<sup>F521</sup>100A.**—(1) No person shall use, or cause or permit to be used, on a road a vehicle displaying the rectangular plate described in the definition of “low platform trailer” in the Table in regulation 3(2) or anything resembling such a plate at a speed exceeding 40 mph.

(2) No person shall use, or cause or permit to be used on a road a vehicle displaying the rectangular plate described in Schedule 13 (Plate for restricted speed vehicle) or anything resembling such a plate at a speed exceeding 50 mph.]

#### Textual Amendments

**F521** Reg. 100A inserted (2.11.1990) by [The Road Vehicles \(Construction and Use\) \(Amendment\) \(No. 4\) Regulations 1990 \(S.I. 1990/1981\)](#), regs. 1, **10**

#### Parking in darkness

**101.**—(1) Save as provided in paragraph (2) no person shall, except with the permission of a police officer in a uniform, cause or permit any motor vehicle to stand on a road at any time between <sup>F522</sup>... sunset and <sup>F522</sup>... sunrise unless the near side of the vehicle is as close as may be to the edge of the carriageway.

(2) The provisions of paragraph (1) do not apply in respect of any motor vehicle—

- (a) being used for [<sup>F523</sup>fire brigade][<sup>F523</sup>relevant authority (as defined in section 6 of the Fire (Scotland) Act 2005 (asp 5))][<sup>F524</sup>or, in England or Wales, fire and rescue authority][<sup>F525</sup>or, in England, fire and rescue authority], ambulance or police purposes or for defence

**Status:** Point in time view as at 31/03/2009.

**Status:** This revised version has been created from an electronic version contributed by Westlaw which was originally derived from the printed publication. **Read more** (See end of Document for details) **Changes to legislation:** There are currently no known outstanding effects for the The Road Vehicles (Construction and Use) Regulations 1986. (See end of Document for details)

purposes (including civil defence purposes) if compliance with those provisions would hinder or be likely to hinder the use of the vehicle for the purpose for which it is being used on that occasion;

- (b) being used in connection with—
- (i) any building operation or demolition;
  - (ii) the repair of any other vehicle;
  - (iii) the removal of any obstruction to traffic;
  - (iv) the maintenance, repair or reconstruction of any road; or
  - (v) the laying, erection, alteration or repair in or near to any road of any sewer, main, pipe or apparatus for the supply of gas, water or electricity, of any [<sup>F526</sup>electronic communications apparatus] as defined in Schedule 2 to the Telecommunication Act 1984 or of the apparatus of any electric transport undertaking,
- if, in any such case, compliance with those provisions would hinder or be likely to hinder the use of the vehicle for the purpose for which it is being used on that occasion;
- (c) on any road in which vehicles are allowed to proceed in one direction only;
- (d) standing on a part of a road set aside for the parking of vehicles or as a stand for hackney carriages or as a stand for buses or as a place at which such vehicles may stop for a longer time than is necessary for the taking up and setting down of passengers where compliance with those provisions would conflict with the provisions of any order, regulations or byelaws governing the use of such part of a road for that purpose; or
- (e) waiting to set down or pick up passengers in accordance with regulations made or directions given by a chief officer of police in regard to such setting down or picking up.

#### Textual Amendments

- F522** Words in reg. 101(1) omitted (17.10.1991) by virtue of [The Road Vehicles \(Construction and Use\) \(Amendment\) \(No. 4\) Regulations 1991](#) (S.I. 1991/2125), regs. 1, **10**
- F523** Words in reg. 101(2)(a) substituted (S.) (2.8.2005) by [The Fire \(Scotland\) Act 2005 \(Consequential Modifications and Amendments\) \(No. 2\) Order 2005](#) (S.S.I. 2005/344), art. 1, **sch. para. 5(4)(d)**; S.S.I. 2005/392, **art. 2**
- F524** Words in reg. 101(2)(a) inserted (W.) (25.10.2005) by [The Fire and Rescue Services Act 2004 \(Consequential Amendments\) \(Wales\) Order 2005](#) (S.I. 2005/2929), arts. 1(1), **11(4)(d)**
- F525** Words in reg. 101(2)(a) inserted (E.) (30.12.2004) by [The Fire and Rescue Services Act 2004 \(Consequential Amendments\) \(England\) Order 2004](#) (S.I. 2004/3168), arts. 1(1), **10(4)(d)**
- F526** Words in reg. 101(2)(b)(v) substituted (17.9.2003) by [The Communications Act 2003 \(Consequential Amendments\) Order 2003](#) (S.I. 2003/2155), art. 1(1), **Sch. 1 para. 27(3)**

#### Commencement Information

- I93** Reg. 101 in force at 11.8.1986, see [reg. 1](#)

### Passengers on motor cycles

**102.** If any person in addition to the driver is carried astride a two-wheeled motor cycle on a road (whether a sidecar is attached to it or not) suitable supports or rests for the feet shall be available on the motor cycle for that person.

**Status:** This revised version has been created from an electronic version contributed by Westlaw which was originally derived from the printed publication. **Read more** (See end of Document for details)**Changes to legislation:** There are currently no known outstanding effects for the The Road Vehicles (Construction and Use) Regulations 1986. (See end of Document for details)

**Commencement Information**

**194** [Reg. 102](#) in force at 11.8.1986, see [reg. 1](#)

**Obstruction**

**103.** No person in charge of a motor vehicle or trailer shall cause or permit the vehicle to stand on a road so as to cause any unnecessary obstruction of the road.

**Commencement Information**

**195** [Reg. 103](#) in force at 11.8.1986, see [reg. 1](#)

**Driver's control**

**104.** No person shall drive or cause or permit any other person to drive, a motor vehicle on a road if he is in such a position that he cannot have proper control of the vehicle or have a full view of the road and traffic ahead.

**Commencement Information**

**196** [Reg. 104](#) in force at 11.8.1986, see [reg. 1](#)

**Opening of doors**

**105.** No person shall open, or cause or permit to be opened, any door of a vehicle on a road so as to injure or endanger any person.

**Commencement Information**

**197** [Reg. 105](#) in force at 11.8.1986, see [reg. 1](#)

**Reversing**

**106.** No person shall drive, or cause or permit to be driven, a motor vehicle backwards on a road further than may be requisite for the safety or reasonable convenience of the occupants of the vehicle or other traffic, unless it is a road roller or is engaged in the construction, maintenance or repair of the road.

**Commencement Information**

**198** [Reg. 106](#) in force at 11.8.1986, see [reg. 1](#)

**Leaving motor vehicles unattended**

**107.—(1)** Save as provided in paragraph (2), no person shall leave, or cause or permit to be left, on a road a motor vehicle which is not attended by a person licensed to drive it unless the engine is stopped and any parking brake with which the vehicle is required to be equipped is effectively set.

**Status:** Point in time view as at 31/03/2009.

**Status:** This revised version has been created from an electronic version contributed by Westlaw which was originally derived from the printed publication. **Read more** (See end of Document for details)**Changes to legislation:** There are currently no known outstanding effects for the The Road Vehicles (Construction and Use) Regulations 1986. (See end of Document for details)

(2) The requirement specified in paragraph (1) as to the stopping of the engine shall not apply in respect of a vehicle—

- (a) being used for ambulance, [<sup>F527</sup>fire brigade][<sup>F527</sup>relevant authority (as defined in section 6 of the Fire (Scotland) Act 2005 (asp 5))][<sup>F528</sup>or, in England or Wales, fire and rescue authority][<sup>F529</sup>or, in England, fire and rescue authority] or police purposes; or
- (b) in such a position and condition as not to be likely to endanger any person or property and engaged in an operation which requires its engine to be used to—
  - (i) drive machinery forming part of, or mounted on, the vehicle and used for purposes other than driving the vehicle; or
  - (ii) maintain the electrical power of the batteries of the vehicle at a level required for driving that machinery or apparatus.

(3) In this regulation “parking brake” means a brake fitted to a vehicle in accordance with requirement 16 or 18 in Schedule 3.

#### Textual Amendments

**F527** Words in [reg. 107\(2\)\(a\)](#) substituted (S.) (2.8.2005) by [The Fire \(Scotland\) Act 2005 \(Consequential Modifications and Amendments\) \(No. 2\) Order 2005 \(S.S.I. 2005/344\)](#), art. 1, [sch. para. 5\(4\)\(e\)](#); S.S.I. 2005/392, [art. 2](#)

**F528** Words in [reg. 107\(2\)\(a\)](#) inserted (W.) (25.10.2005) by [The Fire and Rescue Services Act 2004 \(Consequential Amendments\) \(Wales\) Order 2005 \(S.I. 2005/2929\)](#), arts. 1(1), [11\(4\)\(e\)](#)

**F529** Words in [reg. 107\(2\)\(a\)](#) inserted (E.) (30.12.2004) by [The Fire and Rescue Services Act 2004 \(Consequential Amendments\) \(England\) Order 2004 \(S.I. 2004/3168\)](#), arts. 1(1), [10\(4\)\(e\)](#)

#### Commencement Information

**I99** [Reg. 107](#) in force at 11.8.1986, see [reg. 1](#)

### Securing of suspended implements

**108.** Where a vehicle is fitted with any apparatus or appliance designed for lifting and part of the apparatus or appliance consists of a suspended implement, the implement shall at all times while the vehicle is in motion on a road and when the implement is not attached to any load supported by the appliance or apparatus be so secured either to the appliance or apparatus or to some part of the vehicle that no danger is caused or is likely to be caused to any person on the vehicle or on the road.

#### Commencement Information

**I100** [Reg. 108](#) in force at 11.8.1986, see [reg. 1](#)

### Television sets

**109.**—(1) No person shall drive, or cause or permit to be driven, a motor vehicle on a road, if the driver is in such a position as to be able to see, whether directly or by reflection, a television receiving apparatus or other cinematographic apparatus used to display anything other than information—

- (a) about the state of the vehicle or its equipment;
- (b) about the location of the vehicle and the road on which it is located;
- (c) to assist the driver to see the road adjacent to the vehicle; or
- (d) to assist the driver to reach his destination.



(2) In this regulation “television receiving apparatus” means any cathode ray tube carried on a vehicle and on which there can be displayed an image derived from a television broadcast, a recording or a camera or computer.

**Commencement Information**

**1101** Reg. 109 in force at 11.8.1986, see [reg. 1](#)

**[<sup>F530</sup> Mobile telephones**

**110.**—(1) No person shall drive a motor vehicle on a road if he is using—

- (a) a hand-held mobile telephone; or
- (b) a hand-held device of a kind specified in paragraph (4).

(2) No person shall cause or permit any other person to drive a motor vehicle on a road while that other person is using—

- (a) a hand-held mobile telephone; or
- (b) a hand-held device of a kind specified in paragraph (4).

(3) No person shall supervise a holder of a provisional licence if the person supervising is using—

- (a) a hand-held mobile telephone; or
- (b) a hand-held device of a kind specified in paragraph (4),

at a time when the provisional licence holder is driving a motor vehicle on a road.

(4) A device referred to in paragraphs (1)(b), (2)(b) and (3)(b) is a device, other than a two-way radio, which performs an interactive communication function by transmitting and receiving data.

(5) A person does not contravene a provision of this regulation if, at the time of the alleged contravention—

- (a) he is using the telephone or other device to call the police, fire, ambulance or other emergency service on 112 or 999;
- (b) he is acting in response to a genuine emergency; and
- (c) it is unsafe or impracticable for him to cease driving in order to make the call (or, in the case of an alleged contravention of paragraph (3)(b), for the provisional licence holder to cease driving while the call was being made).

(6) For the purposes of this regulation—

- (a) a mobile telephone or other device is to be treated as hand-held if it is, or must be, held at some point during the course of making or receiving a call or performing any other interactive communication function;
- (b) a person supervises the holder of a provisional licence if he does so pursuant to a condition imposed on that licence holder prescribed under section 97(3)(a) of the Road Traffic Act 1988 (grant of provisional licence);
- (c) “interactive communication function” includes the following:
  - (i) sending or receiving oral or written messages;
  - (ii) sending or receiving facsimile documents;
  - (iii) sending or receiving still or moving images; and
  - (iv) providing access to the internet;
- (d) “two-way radio” means any wireless telegraphy apparatus which is designed or adapted—

**Status:** Point in time view as at 31/03/2009.

**Status:** This revised version has been created from an electronic version contributed by Westlaw which was originally derived from the printed publication. **Read more** (See end of Document for details)**Changes to legislation:** There are currently no known outstanding effects for the The Road Vehicles (Construction and Use) Regulations 1986. (See end of Document for details)

- (i) for the purpose of transmitting and receiving spoken messages; and
- (ii) to operate on any frequency other than 880 MHz to 915 MHz, 925 MHz to 960 MHz, 1710 MHz to 1785 MHz, 1805 MHz to 1880 MHz, 1900 MHz to 1980 MHz or 2110 MHz to 2170 MHz; and
- (e) “wireless telegraphy” has the same meaning as in section 19(1) of the Wireless Telegraphy Act 1949.]

**Textual Amendments**

**F530** Reg. 110 inserted (1.12.2003) by The Road Vehicles (Construction and Use) (Amendment) (No. 4) Regulations 2003 (S.I. 2003/2695), regs. 1, 2

25th June 1986

*John Moore*  
Secretary of State for Transport

**Status:** This revised version has been created from an electronic version contributed by Westlaw which was originally derived from the printed publication. **Read more** (See end of Document for details)**Changes to legislation:** There are currently no known outstanding effects for the The Road Vehicles (Construction and Use) Regulations 1986. (See end of Document for details)

## SCHEDULE 1

## REGULATIONS REVOKED BY REGULATION 2

**Commencement Information**

**I102** Sch. 1 in force at 11.8.1986, see [reg. 1](#)

<i>Title</i>	<i>Year and Number</i>
The Motor Vehicles (Construction and Use) (Track Laying Vehicles) Regulations 1955	S.I. 1955/990
The Motor Vehicles (Construction and Use) (Track Laying Vehicles) (Amendment) Regulations 1957	S.I. 1957/439
The Motor Vehicles (Construction and Use) (Track Laying Vehicles) (Amendment) (No. 2) Regulations 1957	S.I. 1957/972
The Motor Vehicles (Construction and Use) (Track Laying Vehicles) (Amendment) Regulations 1959	S.I. 1959/2053
The Motor Vehicles (Construction and Use) (Track Laying Vehicles) (Amendment) Regulations 1984	S.I. 1984/817
The Motor Vehicles (Construction and Use) (Track Laying Vehicles) (Amendment) (No. 2) Regulations 1984	S.I. 1984/1811
The Motor Vehicles (Construction and Use) Regulations 1978	S.I. 1978/1017
The Motor Vehicles (Construction and Use) (Amendment) Regulations 1978	S.I. 1978/1233
The Motor Vehicles (Construction and Use) (Amendment) (No. 3) Regulations 1978	S.I. 1978/1235
The Motor Vehicles (Construction and Use) (Amendment) (No. 4) Regulations 1978	S.I. 1978/1263
The Motor Vehicles (Construction and Use) (Amendment) (No. 5) Regulations 1978	S.I. 1978/1317
The Motor Vehicles (Construction and Use) (Amendment) Regulations 1979	S.I. 1979/138
The Motor Vehicles (Construction and Use) (Amendment) (No. 2) Regulations 1979	S.I. 1979/843
The Motor Vehicles (Construction and Use) (Amendment) (No. 3) Regulations 1979	S.I. 1979/1062
The Motor Vehicles (Construction and Use) (Amendment) Regulations 1980	S.I. 1980/140
The Motor Vehicles (Construction and Use) (Amendment) (No. 2) Regulations 1980	S.I. 1980/139
The Motor Vehicles (Construction and Use) (Amendment) (No. 3) Regulations 1980	S.I. 1980/287

**Status:** Point in time view as at 31/03/2009.

**Status:** This revised version has been created from an electronic version contributed by Westlaw which was originally derived from the printed publication. **Read more** (See end of Document for details)**Changes to legislation:** There are currently no known outstanding effects for the The Road Vehicles (Construction and Use) Regulations 1986. (See end of Document for details)

<i>Title</i>	<i>Year and Number</i>
The Motor Vehicles (Construction and Use) (Amendment) (No. 4) Regulations 1980	S.I. 1980/610
The Motor Vehicles (Construction and Use) (Amendment) (No. 5) Regulations 1980	S.I. 1980/880
The Motor Vehicles (Construction and Use) (Amendment) (No. 6) Regulations 1980	S.I. 1980/1166
The Motor Vehicles (Construction and Use) (Amendment) (No. 7) Regulations 1980	S.I. 1980/1789
The Motor Vehicles (Construction and Use) (Amendment) Regulations 1981	S.I. 1981/261
The Motor Vehicles (Construction and Use) (Amendment) (No. 2) Regulations 1981	S.I. 1981/697
The Motor Vehicles (Construction and Use) (Amendment) (No. 3) Regulations 1981	S.I. 1981/915
The Motor Vehicles (Construction and Use) (Amendment) (No. 4) Regulations 1981	S.I. 1981/1189
The Motor Vehicles (Construction and Use) (Amendment) (No. 5) Regulations 1981	S.I. 1981/1580
The Motor Vehicles (Construction and Use) (Amendment) (No. 6) Regulations 1981	S.I. 1981/1663
The Motor Vehicles (Construction and Use) (Amendment) (No. 7) Regulations 1981	S.I. 1981/1688
The Motor Vehicles (Construction and Use) (Amendment) Regulations 1982	S.I. 1982/1057
The Motor Vehicles (Construction and Use) (Amendment) (No. 2) Regulations 1982	S.I. 1982/1132
The Motor Vehicles (Construction and Use) (Amendment) (No. 3) Regulations 1982	S.I. 1982/1223
The Motor Vehicles (Construction and Use) (Amendment) (No. 4) Regulations 1982	S.I. 1982/1272
The Motor Vehicles (Construction and Use) (Amendment) (No. 5) Regulations 1982	S.I. 1982/1422
The Motor Vehicles (Construction and Use) (Amendment) (No. 6) Regulations 1982	S.I. 1982/1480
The Motor Vehicles (Construction and Use) (Amendment) (No. 7) Regulations 1982	S.I. 1982/1576
The Motor Vehicles (Construction and Use) (Amendment) Regulations 1983	S.I. 1983/112
The Motor Vehicles (Construction and Use) (Amendment) (No. 2) Regulations 1983	S.I. 1983/471

**Status:** Point in time view as at 31/03/2009.

**Status:** This revised version has been created from an electronic version contributed by Westlaw which was originally derived from the printed publication. **Read more** (See end of Document for details)**Changes to legislation:** There are currently no known outstanding effects for the The Road Vehicles (Construction and Use) Regulations 1986. (See end of Document for details)

<i>Title</i>	<i>Year and Number</i>
The Motor Vehicles (Construction and Use) (Amendment) (No. 3) Regulations 1983	S.I. 1983/932
The Motor Vehicles (Construction and Use) (Amendment) Regulations 1984	S.I. 1984/195
The Motor Vehicles (Construction and Use) (Amendment) (No. 2) Regulations 1984	S.I. 1984/331
The Motor Vehicles (Construction and Use) (Amendment) (No. 3) Regulations 1984	S.I. 1984/386
The Motor Vehicles (Construction and Use) (Amendment) (No. 4) Regulations 1984	S.I. 1984/679
The Motor Vehicles (Construction and Use) (Amendment) (No. 5) Regulations 1984	S.I. 1984/813
The Motor Vehicles (Construction and Use) (Amendment) (No. 6) Regulations 1984	S.I. 1984/1543
The Motor Vehicles (Construction and Use) (Amendment) (No. 7) Regulations 1984	S.I. 1984/1809
The Motor Vehicles (Construction and Use) (Amendment) Regulations 1985	S.I. 1985/91
The Motor Vehicles (Construction and Use) (Amendment) (No. 2) Regulations 1985	S.I. 1985/730
The Motor Vehicles (Construction and Use) (Amendment) (No. 3) Regulations 1985	S.I. 1985/1363
The Motor Vehicles (Construction and Use) (Amendment) (No. 4) Regulations 1985	S.I. 1985/2039
The Motor Vehicles (Construction and Use) (Amendment) (No. 5) Regulations 1985	S.I. 1985/2051

## SCHEDULE 2

(see regulation 3)

## COMMUNITY DIRECTIVES AND ECE REGULATIONS

**Commencement Information**

**I103** Sch. 2 in force at 11.8.1986, see [reg. 1](#)

**Status:** Point in time view as at 31/03/2009.

**Status:** This revised version has been created from an electronic version contributed by Westlaw which was originally derived from the printed publication. **Read more** (See end of Document for details)**Changes to legislation:** There are currently no known outstanding effects for the The Road Vehicles (Construction and Use) Regulations 1986. (See end of Document for details)

**TABLE I**  
**Community Directives**

1 Item	2 Reference No.	3 Community Directives				4 Item No. in Schedule 1 to—	
		(a) Date	(b) Official Journal Reference	(c) Subject matter	(d) Previous Directives included	(a) The Type Approval (Great Britain) Regulations	(b) The Type Approval for Goods Vehicles Regulations
1	70/157	6.2.70	L42, 23.2.70, p.16	The permissible sound level and the exhaust system of motor vehicles			
2	70/220	20.3.70	L76, 6.4.70, p.1	Measures to be taken against air pollution by gases from spark ignition engines of motor vehicles			
3	70/221	20.3.70	L76, 6.4.70, p. 23	Liquid fuel tanks and rear protective devices for motor vehicles and their trailers			
4	70/388	27.7.70	L176, 10.8.70, p. 12	Audible warning devices for motor vehicles			
5	71/127	1.3.71	L68, 22.3.71, p. 1	The rear-view mirrors of motor vehicles		10	
6	71/320 <sup>31</sup>	26.7.71	L202, 6.9.71, p. 37	The braking devices of certain categories of motor vehicles and their trailers			
7	72/245	20.6.72	L152, 6.7.72, p. 15	The suppression of radio interference produced by spark ignition engines fitted to motor vehicles		2A	5A
8	72/306	2.8.72	L190, 20.8.72, p. 1	The emission of pollutants from diesel engines for use in vehicles		5	3
9	73/350	7.11.73	L321, 22.11.73, p. 33	The permissible sound level and the exhaust	70/157		4A

**Status:** Point in time view as at 31/03/2009.

**Status:** This revised version has been created from an electronic version contributed by Westlaw which was originally derived from the printed publication. **Read more** (See end of Document for details) **Changes to legislation:** There are currently no known outstanding effects for the The Road Vehicles (Construction and Use) Regulations 1986. (See end of Document for details)

1 Item	2 Reference No.	3 Community Directives				4 Item No. in Schedule 1 to—	
		(a) Date	(b) Official Journal Reference	(c) Subject matter	(d) Previous The Type Directives included	(a) The Type Approval (Great Britain) Regulations	(b) The Type Approval for Goods Vehicles Regulations
				system of motor vehicles			
10	74/132	11.2.74	L74, 19.3.74, p. 7	The braking devices of certain categories of motor vehicles and their trailers	71/320		
11	74/151	4.3.74	L84, 28.3.74, p. 25	Parts and characteristics of agricultural motor vehicles (see Note 1)			
12	74/290	28.5.74	L159, 15.6.74, p. 61	Measures to be taken against air pollution by gases from spark ignition engines for motor vehicles	70/220		
13	74/346	25.6.74	L191, 15.7.74, p. 1	Rear view mirrors for agricultural motor vehicles (see Note 1)			
14	74/347	25.6.74	L191, 15.7.74, p. 5	Field of vision and windscreen wipers for agricultural motor vehicles (see Note 1)			
15	74/483	17.9.74	L266, 2.10.74, p. 4	External projections of motor vehicles		19	
16	75/322	20.5.75	L147, 9.6.75, p. 28	Suppression of radio interference from spark ignition engines of agricultural motor vehicles (see Note 1)			
17	75/443	26.6.75	L196, 26.7.75, p. 1	Reverse and speedometer equipment of motor vehicles		20	
18	75/524	25.7.75	L236, 8.9.75, p. 3	The braking devices of certain categories of motor vehicles and their trailers	71/320 as amended by 74/132	13A	

**Status:** Point in time view as at 31/03/2009.

**Status:** This revised version has been created from an electronic version contributed by Westlaw which was originally derived from the printed publication. **Read more** (See end of Document for details)**Changes to legislation:** There are currently no known outstanding effects for the The Road Vehicles (Construction and Use) Regulations 1986. (See end of Document for details)

1 Item	2 Reference No.	3 Community Directives				4 Item No. in Schedule 1 to—	
		(a) Date	(b) Official Journal Reference	(c) Subject matter	(d) Previous The Type Directives included	(a) Approval (Great Britain) Regulations	(b) The Type Approval for Goods Vehicles Regulations
19	76/114	18.12.75	L24, 30.1.76, p. 1	Statutory plates and inscriptions for motor vehicles and trailers			
20	76/115	18.12.75	L24, 30.1.76, p. 6	Anchorage for motor vehicle seat belts		12A	
21	76/432	6.4.76	L122, 8.5.76, p. 1	Braking devices of agricultural vehicles (see Note 1)			
22	77/102	30.11.76	L32, 3.2.77, p. 32	Measures to be taken against air pollution by gases from spark ignition engines of motor vehicles	70/220 as amended by 74/290		
23	77/212	8.3.77	L66, 12.3.77, p. 33	The permissible sound level and the exhaust system of motor vehicles	70/157 as amended by 73/350	14B	4B, 4C, 4D
24	77/537	28.6.77	L220, 29.8.77, p. 38	Emission of pollution from diesel engines for agricultural motor vehicles (see Note 1)			
25	77/541	28.6.77	L220, 29.8.77, p. 95	Seat belts and restraint systems for motor vehicles		12A	
26	77/649	27.9.77	L267, 19.10.77, p. 1	Field of vision of motor vehicle drivers			
27	78/318	21.12.77	L81, 28.3.78, p. 49	Wiper and washer systems of motor vehicles		22	
28	78/507	19.5.78	L155, 13.6.78, p. 31	Statutory plates and inscriptions for motor vehicles and trailers	76/114		
29	78/549	12.6.78	L168, 26.6.78, p. 45	Wheel guards of motor vehicles			
30	78/665	14.7.78	L223, 14.8.78, p. 48	Measures to be taken against air pollution	70/220 as	4B, 4C	2



**Status:** Point in time view as at 31/03/2009.

**Status:** This revised version has been created from an electronic version contributed by Westlaw which was originally derived from the printed publication. **Read more** (See end of Document for details)**Changes to legislation:** There are currently no known outstanding effects for the The Road Vehicles (Construction and Use) Regulations 1986. (See end of Document for details)

1 Item	2 Reference No.	3 Community Directives				4 Item No. in Schedule 1 to—	
		(a) Date	(b) Official Journal Reference	(c) Subject matter	(d) Previous The Type Directives included	(a) Approval (Great Britain) Regulations	(b) The Type Approval for Goods Vehicles Regulations
				by gases from spark ignition engines of motor vehicles	amended by 74/290 and 77/102		
31	78/1015	23.11.78	L349, 13.12.78, p. 21	The permissible sound level and exhaust system of motorcycles			
32	79/488	18.4.79	L128, 26.5.79, p. 1	External projections of motor vehicles	74/483	19A	
33	79/489	18.4.79	L128, 26.5.79, p. 12	The braking devices of certain categories of motor vehicles and their trailers	71/320 as amended by 74/132 and 75/524	13B	6, 6C
34	79/490	18.4.79	L128, 26.5.79, p. 22	Liquid fuel tanks and rear under-run protection	70/221		
35	79/795	20.7.79	L239, 22.9.79, p. 1	The rear-view mirrors of motor vehicles	71/127	10A	
36	79/1073	22.11.79	L331, 27.12.79, p. 20	Field of vision and windscreen wipers for agricultural motor vehicles	74/347		
37	80/780	22.7.80	L229, 30.8.80, p. 49	Rear view mirrors for motor cycles			
38	80/1269	16.12.80	L375, 31.12.80, p. 46	The engine power of motor vehicles			
39	81/334	13.4.81	L131, 18.5.81, p. 6	The permissible sound level and exhaust system of motor vehicles	70/157 as amended by 73/350 and 77/212	14C	4B, 4C, 4D

**Status:** Point in time view as at 31/03/2009.

**Status:** This revised version has been created from an electronic version contributed by Westlaw which was originally derived from the printed publication. **Read more** (See end of Document for details)**Changes to legislation:** There are currently no known outstanding effects for the The Road Vehicles (Construction and Use) Regulations 1986. (See end of Document for details)

1 Item	2 Reference No.	3 Community Directives				4 Item No. in Schedule 1 to—	
		(a) Date	(b) Official Journal Reference	(c) Subject matter	(d) Previous The Type Directives included	(a) Approval (Great Britain) Regulations	(b) The Type Approval for Goods Vehicles Regulations
40	81/575	29.7.81	L209, 29.7.81, p. 30	Anchorage for motor vehicle seat belts	76/115	12A	
41	81/576	29.7.81	L209, 29.7.81, p. 32	Seat belts and restraint systems for motor vehicles	77/541	12A	
42	81/643	29.7.81	L231, 15.8.81, p. 41	Field of vision of motor vehicles drivers	77/649		
43	82/318	2.4.82	L139, 19.5.82, p. 9	Anchorage for motor vehicle seat belts	76/115 as amended by 81/575	12A	
44	82/319	2.4.82	L139, 19.5.82, p. 17	Seat belts and restraint systems for motor vehicles	77/541 as amended by 81/576	12A	
45	82/890	17.12.82	L378, 31.12.82, p. 45	Agricultural motor vehicles			
46	83/351	16.6.83	L197, 20.7.83, p. 1	Air pollution by gases from positive ignition engines of motor vehicles	70/220 as amended by 74/290, 77/102 and 78/665	4C	
47	84/372	3.7.84	L196, 26.7.84, p. 47	The permissible sound level and exhaust system of motor vehicles	70/157 as amended by 73/350, 77/212 and 81/334		
48	84/424	3.9.84	L238, 6.9.84, p. 31	The permissible sound level and exhaust	70/157 as amended		

**Status:** Point in time view as at 31/03/2009.

**Status:** This revised version has been created from an electronic version contributed by Westlaw which was originally derived from the printed publication. **Read more** (See end of Document for details)**Changes to legislation:** There are currently no known outstanding effects for the The Road Vehicles (Construction and Use) Regulations 1986. (See end of Document for details)

1 Item	2 Reference No.	3 Community Directives				4 Item No. in Schedule 1 to—	
		(a) Date	(b) Official Journal Reference	(c) Subject matter	(d) Previous Directives included	(a) The Type Approval (Great Britain) Regulations	(b) The Type Approval for Goods Vehicles Regulations
				system of motor vehicles	by 73/350, 77/212, 81/334 and 84/372		
[ <sup>F532</sup> 48A	85/3	19.12.84	L2, 3.1.85, p.14	The weights dimensions and other technical characteristics of certain road vehicles]			
49	85/205	18.2.85	L90, 29.3.85, p.1	Mirrors	71/127 as amended by 79/795	10B	
[ <sup>F533</sup> 49A	85/210	20.3.85	L96, 3.4.85, p.25	The lead content of petrol]			
[ <sup>F534</sup> 50][ <sup>F535</sup> 50A	[ <sup>F536</sup> 85/247][ <sup>F537</sup> 85/247]	[2.85]	[ <sup>F537</sup> L380, 31.12.85, p.1]	[ <sup>F538</sup> The braking devices of certain motor vehicles and their trailers]	[ <sup>F539</sup> 71/320 as amended by 74/132, 75/524 and 79/489]		
[ <sup>F540</sup> 50A	86/360	24.7.86	L217, 5.8.86, p.19	The weights dimensions and other technical characteristics of certain road vehicles	85/3]		
[ <sup>F541</sup> 51	86/56	26.11.86	L327, 27.11.86, p.49	Mirrors	71/127 as amended by 79/795 and 85/205]		

**Status:** Point in time view as at 31/03/2009.

**Status:** This revised version has been created from an electronic version contributed by Westlaw which was originally derived from the printed publication. **Read more** (See end of Document for details)**Changes to legislation:** There are currently no known outstanding effects for the The Road Vehicles (Construction and Use) Regulations 1986. (See end of Document for details)

1 Item	2 Reference No.	3 Community Directives				4 Item No. in Schedule 1 to—	
		(a) Date	(b) Official Journal Reference	(c) Subject matter	(d) Previous The Type Directives included	(a) Approval (Great Britain) Regulations	(b) Approval for Goods Vehicles Regulations
[F542]51A	87/56	18.12.86	L24, 27.1.87, p.42.	The permissible sound level and exhaust system of motorcycles	78/1015]		
[F543]52	88/76	3.12.87	L36, 9.2.88, p.1	Measures to be taken against air pollution by gases from the engines of motor vehicles	70/220 as amended by 74/290, 77/102, 78/665, and 83/351	4D	2B]
[F544]53	89/297	13.4.89	L124, 5.5.89,p.1.	Lateral protection (side guards) of certain motor vehicles and their trailers]			
[F545]54	88/77	3.12.87	L36, 9.2.88, p.33	Measures to be taken against the emission of gaseous pollutants from diesel engines for use in vehicles		4E	2D
[F546]54A	88/194	24.3.88	L92, 9.4.88 p.47	The braking devices of certain categories of motor vehicles and their trailers	71/320 as amended by 74/132, 75/524, 79/489 and 85/647]		
[F547]55	88/195	24.3.88	L92, 9.4.88, p.50	Engine power of motor vehicles	80/1269		
55A	88/218	11.4.88	L98, 15.4.88, p.48	The weights dimensions and other technical characteristics of certain road vehicles	85/3 as amended by 86/360		
55B	88/321	16.5.88	L147, 14.6.88, p.77	Mirrors	71/127 as	10C	

**Status:** Point in time view as at 31/03/2009.

**Status:** This revised version has been created from an electronic version contributed by Westlaw which was originally derived from the printed publication. **Read more** (See end of Document for details)**Changes to legislation:** There are currently no known outstanding effects for the The Road Vehicles (Construction and Use) Regulations 1986. (See end of Document for details)

1 Item	2 Reference No.	3 Community Directives				4 Item No. in Schedule 1 to—	
		(a) Date	(b) Official Journal Reference	(c) Subject matter	(d) Previous The Type Directives included	(a) Approval (Great Britain) Regulations	(b) Approval for Goods Vehicles Regulations
55C	88/366	17.5.88	L181, 12.7.88, p.40	Field of vision of motor vehicle drivers	amended by 79/795, 85/205 and 86/562 77/649 as amended by 81/643		
56	88/436	16.6.88	L124, 6.8.88, p.1	Measures to be taken against air pollution by gases from engines of motor vehicles (restriction of particulate pollution emissions from diesel engines)	70/220 as amended by 74/290, 77/102, 78/665, 83/351 and 88/76	4D	2C]
[ <sup>F548</sup> 56A	89/235	13.3.89	L98, 11.4.89. p.1	The permissible sound level and exhaust systems of motor cycles	78/1015 amended by 87/56	—	—]
[ <sup>F549</sup> 56AA]	[ <sup>F550</sup> 89/338	17.4.89	L142, 25.5.89, p.3	The weights dimensions and other technical characteristics of certain road vehicles	85/3 as amended by 86/360 and 88/218]		
57	89/458	18.7.89	L226, 3.8.89, p. 1	Measures to be taken against air pollution by emissions from motor vehicles	70/220 as amended by 74/290, 77/102, 78/665, 83/351,		

**Status:** Point in time view as at 31/03/2009.

**Status:** This revised version has been created from an electronic version contributed by Westlaw which was originally derived from the printed publication. **Read more** (See end of Document for details)**Changes to legislation:** There are currently no known outstanding effects for the The Road Vehicles (Construction and Use) Regulations 1986. (See end of Document for details)

1 Item	2 Reference No.	3 Community Directives				4 Item No. in Schedule 1 to—	
		(a) Date	(b) Official Journal Reference	(c) Subject matter	(d) Previous Directives included	(a) The Type Approval (Great Britain) Regulations	(b) The Type Approval for Goods Vehicles Regulations
[ <sup>F551</sup> 57A89/460]	18.7.89	L226, 3.8.89, p.5	The weights dimensions and other technical characteristics of certain road vehicles	88/76 and 88/436]	85/3 as amended by 86/360, 88/218 and 89/338]		
[ <sup>F551</sup> 57B89/461]	18.7.89	L226, 3.8.89, p.7	The weights dimensions and other technical characteristics of certain road vehicles	85/3 as amended by 86/360, 88/218, 89/338 and 89/460]			
[ <sup>F552</sup> 57C89/491]	17.07.89	L238, 15.08.89 p.43	Motor Vehicles	72/306]			
[ <sup>F553</sup> 58 90/628]	30.10.90	L341, 6.12.90, p.1	Safety belts and restraint systems of motor vehicles	77/541 as amended by 81/576 and 82/319	12A		
59 [ <sup>F554</sup> 90/629]	30.10.90	L341, 6.12.90, p.14	Anchorage for motor vehicle safety belts	76/115 as amended by 81/575 and 82/318	12A		
60	90/360	30.10.90 L341, 6.12.90, p.20	Field of vision of motor vehicle drivers	77/649 as amended			

**Status:** Point in time view as at 31/03/2009.

**Status:** This revised version has been created from an electronic version contributed by Westlaw which was originally derived from the printed publication. **Read more** (See end of Document for details)**Changes to legislation:** There are currently no known outstanding effects for the The Road Vehicles (Construction and Use) Regulations 1986. (See end of Document for details)

1 Item	2 Reference No.	3 Community Directives			4 Item No. in Schedule 1 to—	
		(a) Date	(b) Official Journal Reference	(c) Subject matter	(d) Previous The Type Directives included	(a) The Type Approval (Great Britain) Regulations
[ <sup>F555</sup> 60A	91/60	4.2.91	L37, 9.2.91, p.37	The weights dimensions and other technical characteristics of certain vehicles	85/3 as amended by 86/360, 88/218, 89/338, 89/460 and 89/641]	
[ <sup>F556</sup> 61	91/226	27.3.91	L103, 23.4.91, p.5	Spray-suppression systems of certain categories of motor vehicles and their trailers]		
[ <sup>F557</sup> 61A	91/422	15.7.91	L233, 22.8.91, p.21	The braking devices of certain categories of motor vehicles and their trailers	71/320 as amended by 74/132, 75/524, 79/489, 85/647 and 88/194]	
[ <sup>F558</sup> 62	92/7	10.2.91	L57, 2.3.92, p.29	The weights dimensions and other technical characteristics of certain road vehicles	85/3 as amended by 86/360, 88/218, 89/338, 89/460 and 89/641]	

**Status:** Point in time view as at 31/03/2009.

**Status:** This revised version has been created from an electronic version contributed by Westlaw which was originally derived from the printed publication. **Read more** (See end of Document for details)**Changes to legislation:** There are currently no known outstanding effects for the The Road Vehicles (Construction and Use) Regulations 1986. (See end of Document for details)

1 Item	2 Reference No.	3 Community Directives				4 Item No. in Schedule 1 to—	
		(a) Date	(b) Official Journal Reference	(c) Subject matter	(d) Previous The Type Directives included	(a) Approval (Great Britain) Regulations	(b) Approval for Goods Vehicles Regulations
[F559]63	91/441	26.6.91	L242, 30.8.91, p.1	Measures to be taken against air pollution by emissions from motor vehicles	70/220 as amended by 74/290, 77,102, 78/665, 83/351, 88/76, 88/436 and 89/458	4G	2F]
[F559]64	91/542	1.10.91	L295, 25.10.91, p.1	Measures to be taken against the emission of gaseous pollutants from diesel engines for use in vehicles	88/77	4H	2G]
[F560]64A	92/6	10.2.92	L57, 2.3.92, p.27	The installation and use of speed limitation devices]			
[F561]65	92/22	31.3.92	L129, 14.5.92, p. 11	Safety glazing and glazing materials on motor vehicles and their trailers	—	—	—]
[F561]66	92/23	31.3.92	L129, 14.5.92, p.95	Tyres of motor vehicles and their trailers and their fitting	—	—	—]
[F562]67	92/24	31.3.92	L129, 14.5.92, p154	Speed limitation devices or similar speed limitation onboard certain categories of motor vehicles	—	—	—]
[F563]67A	93/14	5.4.93	L121, 15.5.93, p.1	The braking of two or three-wheel motor vehicles]			
[F564]68	93/59	28.6.93		Measures to be taken against air pollution by	70/220 as amended	4K	2I]



**Status:** Point in time view as at 31/03/2009.

**Status:** This revised version has been created from an electronic version contributed by Westlaw which was originally derived from the printed publication. **Read more** (See end of Document for details)**Changes to legislation:** There are currently no known outstanding effects for the The Road Vehicles (Construction and Use) Regulations 1986. (See end of Document for details)

1 Item	2 Reference No.	3 Community Directives				4 Item No. in Schedule 1 to—	
		(a) Date	(b) Official Journal Reference	(c) Subject matter	(d) Previous The Type Directives included	(a) Approval (Great Britain) Regulations	(b) The Type Approval for Goods Vehicles Regulations
				emissions from motor vehicles	by 74/290, 77/102, 78/665, 83/351, 88/76, 88/436, 89/458 and 91/441		
[F565	69 94/12	23.3.94.	L100, 19.4.94, p.42	Measures to be taken against air pollution by emissions from motor vehicles	70/220 as amended by 74/290, 77/102, 78/665, 83/351, 88/76, 88/436, 89/458, 91/441 and 93/59	4L	2J]
[F566	69A94/20	30.5.94	L195, 29.7.94, p.1	Mechanical coupling devices of motor vehicles and their trailers]			
[F567	70 92/97	10.11.92	L371, 19.12.92, p.1	Permissible sound level and the exhaust system of motor vehicles	70/157 as amended by 73/350, 77/212, 81/334, 84/372 and 84/424	14G	4F

**Status:** Point in time view as at 31/03/2009.

**Status:** This revised version has been created from an electronic version contributed by Westlaw which was originally derived from the printed publication. **Read more** (See end of Document for details)**Changes to legislation:** There are currently no known outstanding effects for the The Road Vehicles (Construction and Use) Regulations 1986. (See end of Document for details)

1 Item	2 Reference No.	3 Community Directives				4 Item No. in Schedule 1 to—	
		(a) Date	(b) Official Journal Reference	(c) Subject matter	(d) Previous Directives included	(a) The Type Approval (Great Britain) Regulations	(b) The Type Approval for Goods Vehicles Regulations
71	95/54	31.10.95	L266, 8.11.95, p.1	The suppression of radio interference of motor vehicles	72/245	2B	5B
72	96/1	22.1.96	L40, 17.2.96, p.1	Measures to be taken against the emission of gaseous pollutants from diesel engines for use in vehicles	88/77 as amended by 91/542	4N	2L
73	96/20	27.3.96	L92, 13.4.96, p.23	Permissible sound level and the exhaust system of motor vehicles	70/157 as amended by 73/350, 77/212, 81/334, 84/372, 84/424 and 92/97	141	4G]
[ <sup>F568</sup> 73A	96/36	17.6.96	L178, 17.7.96, p.15	Safety belts and restraint systems of motor vehicles	77/541 as amended by 81/576, 82/319 and 90/628		
73B	96/38	17.6.96	L187, 26.7.96, p.95	Anchorage for motor vehicle safety belts	76/115 as amended by 81/575, 82/318 and 90/629]		
[ <sup>F569</sup> 74	96/53	25.7.96	L 234, 17.9.96, p.59	Maximum dimensions in national and international traffic			

**Status:** Point in time view as at 31/03/2009.

**Status:** This revised version has been created from an electronic version contributed by Westlaw which was originally derived from the printed publication. **Read more** (See end of Document for details) **Changes to legislation:** There are currently no known outstanding effects for the The Road Vehicles (Construction and Use) Regulations 1986. (See end of Document for details)

1 Item	2 Reference No.	3 Community Directives				4 Item No. in Schedule 1 to—	
		(a) Date	(b) Official Journal Reference	(c) Subject matter	(d) Previous The Type Directives included	(a) The Type Approval (Great Britain) Regulations	(b) The Type Approval for Goods Vehicles Regulations
				and maximum weights in international traffic			
[ <sup>F570</sup>	74A96/63	30.9.96	L253, 5.10.96, p.13	Braking devices of wheeled agricultural or forestry tractors	76/432]		
[ <sup>F571</sup>	74B96/69	08.10.96	L282, 1.11.96, p.64	Measures to be taken against air pollution by emissions from motor vehicles	70/220 as amended by 74/290, 77/102, 78/665, 83/351, 88/76, 88/436, 89/491, 91/441, 93/59, 94/12, and 96/44]		
[ <sup>F572</sup>	74C96/96	20.12.96	L46, 17.2.97, p.1	Roadworthiness tests for motor vehicles and their trailers]			
	75 97/19	18.4.97	L 125, 16.5.97, p.1	Liquid fuel tanks and rear under-run protection of motor vehicles and their trailers	70/221 as amended by 79/490 and 81/333		
[ <sup>F573</sup>	75A97/20	18.04.97	L125, 16.05.97, p.21	The measures to be taken against the emission of pollutants from diesel engines for use in vehicles	72/306, as amended by 89/491]		
	76 97/27	22.7.97	L 233, 25.8.97, p.1	Masses and dimensions of certain			

**Status:** Point in time view as at 31/03/2009.

**Status:** This revised version has been created from an electronic version contributed by Westlaw which was originally derived from the printed publication. **Read more** (See end of Document for details)**Changes to legislation:** There are currently no known outstanding effects for the The Road Vehicles (Construction and Use) Regulations 1986. (See end of Document for details)

1 Item	2 Reference No.	3 Community Directives				4 Item No. in Schedule 1 to—	
		(a) Date	(b) Official Journal Reference	(c) Subject matter	(d) Previous Directives included	(a) The Type Approval (Great Britain) Regulations	(b) The Type Approval for Goods Vehicles Regulations
				categories of vehicle and their trailers			
77	97/39	27.4.97	L 177, 5.7.97, p.15	Reverse and speedometer equipment of motor vehicles	75/443]		
[ <sup>F574</sup> 77A	98/12	27.1.98	L81,18.3.98, p.1	The braking devices of certain vehicles and their trailers	71/320 as amended by 74/132, 75/524, 79/489, 85/647, 88/184, 91/422 and 98/12]		
[ <sup>F575</sup> 78	98/69	13.10.98	L350, 28.12.98, p.1	Measures to be taken against air pollution by emissions from motor vehicles	70/220 as amended by 74/290, 77/102, 78/665, 83/351, 88/76, 88/436, 89/491, 91/441, 93/59, 94/12, 96/44 and 96/69		
79	1999/96	13.12.99	L44, 16.2.2000, p.1	Measures to be taken against the emission of gaseous and particulate pollutants from compression	88/77 as amended by 91/542		

**Status:** Point in time view as at 31/03/2009.

**Status:** This revised version has been created from an electronic version contributed by Westlaw which was originally derived from the printed publication. **Read more** (See end of Document for details)**Changes to legislation:** There are currently no known outstanding effects for the The Road Vehicles (Construction and Use) Regulations 1986. (See end of Document for details)

1 Item	2 Reference No.	3 Community Directives				4 Item No. in Schedule 1 to—	
		(a) Date	(b) Official Journal Reference	(c) Subject matter	(d) Previous The Type Directives included	(a) The Type Approval (Great Britain) Regulations	(b) The Type Approval for Goods Vehicles Regulations
80	1999/1025.12.99	L334, 28.12.99, p.43	Measures to be taken against air pollution by emissions from motor vehicles	ignition engines for use in vehicles and the emission of gaseous pollutants from positive ignition engines fuelled with natural gas or liquefied petroleum gas for use in vehicles	70/220 as amended by 74/290, 77/102, 78/665, 83/351, 88/76, 88/436, 89/491, 91/441, 93/59, 94/12, 96/44, 96/69 and 98/69]		
F57681	2001/12.01.2001	L35, 06.2.2001, p. 34	Measures to be taken against air pollution by emissions from motor vehicles	ignition engines for use in vehicles and the emission of gaseous pollutants from positive ignition engines fuelled with natural gas or liquefied petroleum gas for use in vehicles	70/220 as amended by 74/290, 77/102, 78/665, 83/351, 88/76, 88/436, 89/491, 91/441, 93/59, 94/12,		

**Status:** Point in time view as at 31/03/2009.

**Status:** This revised version has been created from an electronic version contributed by Westlaw which was originally derived from the printed publication. **Read more** (See end of Document for details)**Changes to legislation:** There are currently no known outstanding effects for the The Road Vehicles (Construction and Use) Regulations 1986. (See end of Document for details)

1 Item	2 Reference No.	3 Community Directives			4 Item No. in Schedule 1 to—	
		(a) Date	(b) Official Journal Reference	(c) Subject matter	(d) Previous The Type Directives included	(a) The Type Approval (Great Britain) Regulations
					96/44, 96/69, 98/69, and 1999/102]	
F57782	2001/27	10.4.01	L107, 18.4.2001 p.10	Measures to be taken against the emission of gaseous and particulate pollutants from compression- ignition engines for use in vehicles, and the emission of gaseous pollutants from positive-ignition engines fuelled with natural gas or liquefied petroleum gas for use in vehicles	88/77 as amended by 91/542 and 1999/96]	
F57283	2000/306	6.2000	L203, 10.8.2000, p.1	Technical roadside inspection of the roadworthiness of commercial vehicles circulating in the Community]		
F57284	2002/85	11.2002	L57, 4.12.2002, p.327	Installation and use of speed limitation devices for certain categories of motor vehicles in the Community	92/6]	
F57285	2003/263	4.2003	L90, 8.4.2003, p.37	Speed limiters and exhaust emissions of commercial vehicles	2000/30]	
F57286	2003/273	4.2003	L90, 8.4.2003, p.41	Testing of exhaust emissions from motor vehicles	96/96]	
F57287	2003/90	11.2003	L25, 29.1.2004, p.1	Devices for indirect vision	71/127 as	

**Status:** Point in time view as at 31/03/2009.

**Status:** This revised version has been created from an electronic version contributed by Westlaw which was originally derived from the printed publication. **Read more** (See end of Document for details)**Changes to legislation:** There are currently no known outstanding effects for the The Road Vehicles (Construction and Use) Regulations 1986. (See end of Document for details)

1 Item	2 Reference No.	3 Community Directives				4 Item No. in Schedule 1 to—	
		(a) Date	(b) Official Journal Reference	(c) Subject matter	(d) Previous The Type Directives included	(a) The Type Approval (Great Britain) Regulations	(b) The Type Approval for Goods Vehicles Regulations
					amended by 79/795, 85/205, 86/562 and 88/321]		
[ <sup>F572</sup> 88	2004/111.2.2004	L44, 14.2.2004,p.19	Speed limitation devices or similar speed limitation on- board systems of certain categories of motor vehicles	92/24		9A]	
[ <sup>F578</sup> 88A	2005/07.03.2005	L61, 08.03.2005, p.25	The measures to be taken against the emission of pollutants from diesel engines for use in vehicles	72/306, as amended by 89/491, 97/20]			
[ <sup>F572</sup> 89	2005/230.3.2005	L81, 30.3.2005, p.44	Devices for indirect vision	71/127 as replaced by 2003/97]			
[ <sup>F579</sup> 90.	2005/5528.09.05	L275, 20.10.05, p1	The measures to be taken against the emission of gaseous and particulate pollutants from compression-ignition engines for use in vehicles, and the emission of gaseous pollutants from positive-ignition engines fuelled with natural gas or liquefied petroleum gas for use in vehicles]				

**Status:** Point in time view as at 31/03/2009.

**Status:** This revised version has been created from an electronic version contributed by Westlaw which was originally derived from the printed publication. **Read more** (See end of Document for details)**Changes to legislation:** There are currently no known outstanding effects for the The Road Vehicles (Construction and Use) Regulations 1986. (See end of Document for details)

1 Item	2 Reference No.	3 Community Directives			4 Item No. in Schedule 1 to—	
		(a) Date	(b) Official Journal Reference	(c) Subject matter	(d) Previous The Type Directives included	(a) The Type Approval (Great Britain) Regulations
F579	91.2005/78	14.11.05	L31, 29.11.05, p1	The measures to be taken against the emission of gaseous and particulate pollutants from compression-ignition engines for use in vehicles, and the emission of gaseous pollutants from positive ignition engines fuelled with natural gas or liquefied petroleum gas for use in vehicles	2005/55]	
F579	92.2006/51	6.6.06	L152. 7.6.2006, p11	The measures to be taken against the emission of gaseous and particulate pollutants from compression-ignition engines for use in vehicles, and the emission of gaseous pollutants from positive ignition engines fuelled with natural gas or liquefied petroleum gas for use in vehicles	2005/55, 2005/78]	
F580	93.2007/38	11.07.07	L184, 14.7.2007, p.25	Retrofitting of mirrors to certain heavy goods vehicles]		

#### Textual Amendments

**F531** Word in Sch. 2 Table 1 substituted (2.11.1990) by [The Road Vehicles \(Construction and Use\) \(Amendment\) \(No. 4\) Regulations 1990 \(S.I. 1990/1981\)](#), regs. 1, **12(3)(a)**

**F532** Sch. 2 Table 1 Item 48A inserted (1.1.1993) by [The Road Vehicles \(Construction and Use\) \(Amendment\) \(No. 4\) Regulations 1992 \(S.I. 1992/2016\)](#), regs. 1, **9(1)(a)**



**Status:** This revised version has been created from an electronic version contributed by Westlaw which was originally derived from the printed publication. **Read more** (See end of Document for details)**Changes to legislation:** There are currently no known outstanding effects for the The Road Vehicles (Construction and Use) Regulations 1986. (See end of Document for details)

- F533** Sch. 2 Table 1 Item 49A inserted (1.10.1988) by The Road Vehicles (Construction and Use) (Amendment) (No. 6) Regulations 1988 (S.I. 1988/1524), regs. 1, **8(a)**
- F534** Word in Sch. 2 Table 1 inserted (6.5.1987) by The Road Vehicles (Construction and Use) (Amendment) Regulations 1987 (S.I. 1987/676), regs. 1(2), **11(a)**
- F535** Word in Sch. 2 Table 1 inserted (6.5.1987) by The Road Vehicles (Construction and Use) (Amendment) Regulations 1987 (S.I. 1987/676), regs. 1(2), **11(b)**
- F536** Word in Sch. 2 Table 1 inserted (6.5.1987) by The Road Vehicles (Construction and Use) (Amendment) Regulations 1987 (S.I. 1987/676), regs. 1(2), **11(c)**
- F537** Words in Sch. 2 Table 1 inserted (6.5.1987) by The Road Vehicles (Construction and Use) (Amendment) Regulations 1987 (S.I. 1987/676), regs. 1(2), **11(d)**
- F538** Words in Sch. 2 Table 1 inserted (6.5.1987) by The Road Vehicles (Construction and Use) (Amendment) Regulations 1987 (S.I. 1987/676), regs. 1(2), **11(e)**
- F539** Words in Sch. 2 Table 1 inserted (6.5.1987) by The Road Vehicles (Construction and Use) (Amendment) Regulations 1987 (S.I. 1987/676), regs. 1(2), **11(f)**
- F540** Sch. 2 Table 1 Item 50A inserted (1.1.1993) by The Road Vehicles (Construction and Use) (Amendment) (No. 4) Regulations 1992 (S.I. 1992/2016), regs. 1, **9(1)(b)**
- F541** Sch. 2 Table 1 Item 51 inserted (25.7.1988) by The Road Vehicles (Construction and Use) (Amendment) (No. 4) Regulations 1988 (S.I. 1988/1178), regs. 1, **4**
- F542** Sch. 2 Table 1 Item 51A inserted (8.11.1989) by The Road Vehicles (Construction and Use) (Amendment) (No. 3) Regulations 1989 (S.I. 1989/1865), regs. 1, **9** (with reg. 2(2))
- F543** Sch. 2 Table 1 Item 52 inserted (1.10.1988) by The Road Vehicles (Construction and Use) (Amendment) (No. 6) Regulations 1988 (S.I. 1988/1524), regs. 1, **8(b)**
- F544** Sch. 2 Table 1 Item 53 inserted (30.10.1989) by The Road Vehicles (Construction and Use) (Amendment) (No. 2) Regulations 1989 (S.I. 1989/1695), regs. 1, **4** (with reg. 2(2))
- F545** Sch. 2 Table 1 Items 53-57 inserted (26.6.1990) by The Road Vehicles (Construction and Use) (Amendment) (No. 2) Regulations 1990 (S.I. 1990/1131), regs. 1, **6(1)**
- F546** Words in Sch. 2 Table 1 inserted (2.11.1990) by The Road Vehicles (Construction and Use) (Amendment) (No. 4) Regulations 1990 (S.I. 1990/1981), regs. 1, **12(3)(b)**
- F547** Sch. 2 Table 1 Items 54B-56 substituted for Items 55-56 (1.10.1996) by The Road Vehicles (Construction and Use) (Amendment) (No. 5) Regulations 1996 (S.I. 1996/2329), regs. 1, **10(1)**
- F548** Sch. 2 Table 1 Item 56A inserted (1.7.1994) by The Road Vehicles (Construction and Use) (Amendment) Regulations 1994 (S.I. 1994/14), regs. 1(1), **4**
- F549** Sch. 2: Table 1 Item 56A renumbered as Item 56AA (1.7.1994) by The Road Vehicles (Construction and Use) (Amendment) Regulations 1994 (S.I. 1994/14), regs. 1(1), **4**
- F550** Sch. 2 Table 1 Item 56A inserted (1.1.1993) by The Road Vehicles (Construction and Use) (Amendment) (No. 4) Regulations 1992 (S.I. 1992/2016), regs. 1, **9(1)(d)**
- F551** Sch. 2 Table 1 Items 57A, 57B inserted (1.1.1993) by The Road Vehicles (Construction and Use) (Amendment) (No. 4) Regulations 1992 (S.I. 1992/2016), regs. 1, **9(1)(e)**
- F552** Sch. 2 Table 1 Item 57C added (1.12.2007) by The Road Vehicles (Construction and Use) (Amendment) (No. 3) Regulations 2007 (S.I. 2007/3132), regs. 1(1), **3(a)**
- F553** Sch. 2 Table 1 Items 58-60 inserted (7.10.1991) by The Road Vehicles (Construction and Use) (Amendment) (No. 3) Regulations 1991 (S.I. 1991/2003), regs. 1, **6(3)**
- F554** Word in Sch. 2 Table 1 item 59 substituted (1.10.2001) by The Road Vehicles (Construction and Use) (Amendment) (No. 2) Regulations 2001 (S.I. 2001/1043), regs. 1, **7**
- F555** Sch. 2 Table 1 Item 60A inserted (1.1.1993) by The Road Vehicles (Construction and Use) (Amendment) (No. 4) Regulations 1992 (S.I. 1992/2016), regs. 1, **9(1)(f)**
- F556** Sch. 2 Table 1 Item 61 inserted (1.4.1992) by The Road Vehicles (Construction and Use) (Amendment) (No. 3) Regulations 1992 (S.I. 1992/646), regs. 1, **3**
- F557** Sch. 2 Table 1 Item 61A inserted (1.4.1995) by The Road Vehicles (Construction and Use) (Amendment) Regulations 1995 (S.I. 1995/551), regs. 1, **9(2)**
- F558** Sch. 2 Table 1 Item 62 inserted (1.1.1993) by The Road Vehicles (Construction and Use) (Amendment) (No. 4) Regulations 1992 (S.I. 1992/2016), regs. 1, **9(1)(g)**

**Status:** Point in time view as at 31/03/2009.

**Status:** This revised version has been created from an electronic version contributed by Westlaw which was originally derived from the printed publication. **Read more** (See end of Document for details)**Changes to legislation:** There are currently no known outstanding effects for the The Road Vehicles (Construction and Use) Regulations 1986. (See end of Document for details)

- F559** Sch. 2 Table 1 Items 63, 64 inserted (31.12.1992) by The Road Vehicles (Construction and Use) (Amendment) (No. 5) Regulations 1992 (S.I. 1992/2137), regs. 1, **4(1)**
- F560** Sch. 2 Table 1 Item 64A inserted (1.9.1996) by The Road Vehicles (Construction and Use) (Amendment) (No. 3) Regulations 1996 (S.I. 1996/2064), regs. 1(2), **5**
- F561** Sch. 2 Table 1 Items 65, 66 inserted (1.1.1993) by The Road Vehicles (Construction and Use) (Amendment) (No. 7) Regulations 1992 (S.I. 1992/3088), regs. 1, **9(3)**
- F562** Sch. 2 Table 1 Item 67 inserted (1.9.1993) by The Road Vehicles (Construction and Use) (Amendment) (No. 1) Regulations 1993 (S.I. 1993/1946), regs. 1, **3(3)**
- F563** Sch. 2 Table 1 Item 67A inserted (1.1.1997) by The Road Vehicles (Construction and Use) (Amendment) (No. 7) Regulations 1996 (S.I. 1996/3033), regs. 1, **10**
- F564** Sch. 2 Table 1 Item 68 inserted (1.10.1993) by The Road Vehicles (Construction and Use) (Amendment) (No. 2) Regulations 1993 (S.I. 1993/2199), regs. 1, **5(1)**
- F565** Sch. 2 Table 1 Item 69 inserted (25.9.1995) by The Road Vehicles (Construction and Use) (Amendment) (No. 5) Regulations 1995 (S.I. 1995/2210), regs. 1(2), **5**
- F566** Sch. 2 Table 1 Item 69A inserted (1.8.1998) by The Road Vehicles (Construction and Use) (Amendment) (No. 4) Regulations 1998 (S.I. 1998/1281), regs. 1, **4**
- F567** Sch. 2 Table 1 Items 70-73 inserted (1.10.1996) by The Road Vehicles (Construction and Use) (Amendment) (No. 5) Regulations 1996 (S.I. 1996/2329), regs. 1, **10(2)**
- F568** Sch. 2 Table 1 Items 73A, 73B inserted (1.11.1998) by The Road Vehicles (Construction and Use) (Amendment) (No. 6) Regulations 1998 (S.I. 1998/2429), regs. 1, **8(2)**
- F569** Sch. 2 Table 1 Items 74-77 inserted (1.6.1998) by The Road Vehicles (Construction and Use) (Amendment) (No. 3) Regulations 1998 (S.I. 1998/1188), regs. 1, **14(2)**
- F570** Sch. 2 Table 1 Item 74A inserted (1.11.1998) by The Road Vehicles (Construction and Use) (Amendment) (No. 6) Regulations 1998 (S.I. 1998/2429), regs. 1, **8(3)**
- F571** Sch. 2 Table 1 item 74B inserted (1.1.2001) by The Road Vehicles (Construction and Use) (Amendment) (No. 3) Regulations 2000 (S.I. 2000/3197), regs. 1, **6(1)**
- F572** Sch. 2 Table 1 Items 74C, 83-89 added (12.12.2005) by The Road Vehicles (Construction and Use) (Amendment) (No. 4) Regulations 2005 (S.I. 2005/3165), regs. 1, **6(1)**
- F573** Sch. 2 Table 1 Item 75A added (1.12.2007) by The Road Vehicles (Construction and Use) (Amendment) (No. 3) Regulations 2007 (S.I. 2007/3132), regs. 1(1), **3(b)**
- F574** Sch. 2 Table 1 Item 77A inserted (1.5.2002) by The Road Vehicles (Construction and Use) (Amendment) (No. 4) Regulations 2001 (S.I. 2001/3208), regs. 1(2), **11(2)**
- F575** Sch. 2 Table 1 items 78-80 inserted (1.1.2001) by The Road Vehicles (Construction and Use) (Amendment) (No. 3) Regulations 2000 (S.I. 2000/3197), regs. 1, **6(2)**
- F576** Sch. 2 Table 1 item 81 inserted (1.8.2001) by The Road Vehicles (Construction and Use) (Amendment) (No. 3) Regulations 2001 (S.I. 2001/1825), regs. 1, **4**
- F577** Sch. 2 Table 1 item 82 inserted (1.7.2002) by The Road Vehicles (Construction and Use) (Amendment) (No. 2) Regulations 2002 (S.I. 2002/1474), regs. 1, **3**
- F578** Sch. 2 Table 1 Item 88A added (1.12.2007) by The Road Vehicles (Construction and Use) (Amendment) (No. 3) Regulations 2007 (S.I. 2007/3132), regs. 1(1), **3(c)**
- F579** Sch. 2 Table 1 Items 90-92 added (20.10.2006) by The Road Vehicles (Construction and Use) and Motor Vehicles (Type Approval for Goods Vehicles) (Great Britain) (Amendment) Regulations 2006 (S.I. 2006/2565), regs. 1(2), **5**
- F580** Sch. 2 Table 1 Item 93 added (31.3.2009) by The Road Vehicles (Construction and Use) (Amendment) Regulations 2009 (S.I. 2009/142), regs. 1(2), **8(2)**

NOTE 1. This item is to be interpreted as including reference to the amendments made by Community Directive 82/890 (item 45).

**Status:** Point in time view as at 31/03/2009.

**Status:** This revised version has been created from an electronic version contributed by Westlaw which was originally derived from the printed publication. **Read more** (See end of Document for details)**Changes to legislation:** There are currently no known outstanding effects for the The Road Vehicles (Construction and Use) Regulations 1986. (See end of Document for details)

**TABLE II**  
**ECE REGULATIONS**

1 Item Reference	2 No.	3 ECE Regulations			4 Item No. in Schedule 1 to—		
		(a) Number	(b) Date	(c) Subject matter	(d) Date of amendment	(a) The Type Approval (Great Britain) Regulations	(b) The Type Approval for Goods Vehicles Regulations
1	10	10	17.12.68	Radio interference suppression	—	2	5
2	10.01	10	17.12.68	Radio interference suppression	19.3.78	2A	5A
[ <sup>F581</sup> 2A	10.02		8.12.97	Radio interference suppression]			
[ <sup>F581</sup> 2B	10.02	Amend. 1	9.7.99	Radio interference suppression]			
[ <sup>F581</sup> 2C	10.02	Corr. 1	11.2.00	Radio interference suppression]			
3	13.03	13	29.5.69	Brakes	4.1.79	13C, 13D	6A, 6B, 6D
4	13.04	13	29.5.69	Brakes	11.8.81	13C, 13D	6A, 6B, 6D
[ <sup>F582</sup> 4A]	13.05	13	29.5.69	Brakes	26.11.84	—	—
[ <sup>F583</sup> 4B	13.06	13	29.5.69	Brakes	22.11.90	—	—]
[ <sup>F584</sup> 4C	13.07	13	29.5.69	Brakes	18.9.94	—	—]
[ <sup>F585</sup> 4D	13.08	13	29.5.69	Brakes	26.3.95	—	—]
[ <sup>F585</sup> 4E	13.09	13	29.5.69	Brakes	28.8.96	—	—]
[ <sup>F586</sup> 5A	14	14	30.1.70	Anchorage for seat belts	—	—	—]
6	14.01	14	30.1.70	Anchorage for seat belts	28.4.76	12A	—
[ <sup>F587</sup> 6A	14.02	14	30.1.70	Anchorage for seat belts	22.11.84	12A	—]
[ <sup>F588</sup> 6B	14.03	14	30.1.70	Anchorage for seat belts	29.1.92	—	—
6C	14.04	14	30.1.70	Anchorage for seat belts	18.1.98	—	—
6D	14.05	14	30.1.70	Anchorage for seat belts	4.2.99	—	—]
[ <sup>F589</sup> 6C	14.03		30.1.70	Anchorage for seat belts	29.1.92	12A	—]

**Status:** Point in time view as at 31/03/2009.

**Status:** This revised version has been created from an electronic version contributed by Westlaw which was originally derived from the printed publication. **Read more** (See end of Document for details) **Changes to legislation:** There are currently no known outstanding effects for the The Road Vehicles (Construction and Use) Regulations 1986. (See end of Document for details)

1 Item Reference	2 No.	3 ECE Regulations			4 Item No. in Schedule 1 to—		
		(a) Number	(b) Date	(c) Subject matter	(d) Date of amendment	(a) The Type Approval (Great Britain) Regulations	(b) The Type Approval for Goods Vehicles Regulations
7	15.03	15	11.3.70	Emission of gaseous pollutants	6.3.78	4B	2
8	15.04	15	11.3.70	Emission of gaseous pollutants	20.10.81	4C	2
9	16.03	16	14.8.70	Seat belts and restraint systems	9.12.79	12A	—
10	24.01	24	23.8.71	Emission of pollutants by a diesel engine	11.9.73	5	3
11	24.02	24	23.8.71	Emission of pollutants by a diesel engine	11.2.80	5A	3A
12	24.03	24	23.8.71	Emission of pollutants by a diesel engine	20.4.86	—	—
13	26.01	26	28.4.72	External projections	11.9.73	19	—
[ <sup>F590</sup> 13A0]		30	1.4.75	Pneumatic tyres for motor vehicles and their trailers	—	17,17A	—]
[ <sup>F590</sup> 13B0]		30.01	1.4.75	Pneumatic tyres for motor vehicles and their trailers	25.9.77	17,17A	—]
[ <sup>F591</sup> 13C02]		30	1.4.75	Pneumatic tyres for motor vehicles and their trailers	5.10.87	17,	17A]
14	34	34	25.7.75	Prevention of fire risks	—	—	—
15	34.01	34	25.7.75	Prevention of fire risks	18.1.79	—	—
16	36	36	12.11.75	Construction of public service vehicles	—	—	—
17	39	39	11.7.78	Speedometers	—	20	—
18	43	43	15.9.80	Safety glass and glazing materials	—	15B	—
19	43.01	43	15.9.80	Safety glass and glazing materials	12.11.82	15B	—
20	44	44	1.2.81	Child restraints	—	—	—
21	44.01	44	1.2.81	Child restraints	1.2.84	—	—
[ <sup>F593</sup> 21A6.01]		46.	21.10.84	Mirrors	30.5.88	—	—]

**Status:** Point in time view as at 31/03/2009.

**Status:** This revised version has been created from an electronic version contributed by Westlaw which was originally derived from the printed publication. **Read more** (See end of Document for details)**Changes to legislation:** There are currently no known outstanding effects for the The Road Vehicles (Construction and Use) Regulations 1986. (See end of Document for details)

1 Item Reference No.	2	3 ECE Regulations			4 Item No. in Schedule 1 to—	
		(a) Number	(b) Date	(c) Subject matter	(d) Date of amendment	(a) The Type Approval (Great Britain) Regulations
[F594] 21A(46).02	46	21.10.84.	Mirrors	23.06.05]		
[F595] 21A(49).01	49	14.5.90	emissions of gaseous pollutants	—	—]	
[F596] 21A(49).02	49	15.4.82	Emissions of gaseous pollutants	30.12.92]		
[F597] 21B(51).02	51	18.4.95	Noise emissions from motor vehicles having at least 4 wheels	—	14E	4D(4) or 4E]
[F598] 21B(52).01	52	1.11.1982	Construction of small buses and coaches (M2 and M3)	12.9.1995	—	—]
[F599] [F600] 21B(49)	49	15.4.82.	Emissions of gaseous pollutants	—	—	—]
[F601] [F602] 21C(4)	54	1.3.83	Pneumatic tyres for commercial vehicles and their trailers	—	17A	—]
22 64	64	1.8.85	Vehicles with temporary-use spare wheels/tyres	—	—	—
[F603] 22(67)	67	27.04.90	Vehicles using liquefied petroleum gas	—	—	—
22B 67.01	67	13.11.99	Vehicles using liquefied petroleum gas	—	—	—]
[F604] [F605] 23(78)	78	15.10.88	Brakes	—	—	—]
[F604] [F605] 23(78).01	78	15.10.88	Brakes	22.11.90	—	—]
[F606] 25(83)	83	5.11.89	Emissions of gaseous pollutants	—	4F	2H]
[F606] 26(83).01	83	5.11.89	Emissions of gaseous pollutants	30.12.92	4K	2F]
[F607] 27(107).01	107	18.6.1998	Construction of small buses and coaches (M2 and M3)	12.8.2004	—	—]
[F607] 28(107).02	107	18.6.1998	(Construction of small buses and coaches (M2 and M3)	10.11.2007	—	—]

**Status:** Point in time view as at 31/03/2009.

**Status:** This revised version has been created from an electronic version contributed by Westlaw which was originally derived from the printed publication. **Read more** (See end of Document for details)**Changes to legislation:** There are currently no known outstanding effects for the The Road Vehicles (Construction and Use) Regulations 1986. (See end of Document for details)

## Textual Amendments

- F581** Sch. 2 Table 2 Items 2A-2C inserted (4.9.2002) by The Road Vehicles (Construction and Use) (Amendment) (No. 3) Regulations 2002 (S.I. 2002/2126), regs. 1, **3(1)**
- F582** Sch. 2 Table 2 Item 5 renumbered as Sch. 2 Table 2 Item 4A (1.4.1992) by The Road Vehicles (Construction and Use) (Amendment) Regulations 1992 (S.I. 1992/352), regs. 1, **8(a)**
- F583** Sch. 2 Table 2 Item 4B inserted (1.4.1992) by The Road Vehicles (Construction and Use) (Amendment) Regulations 1992 (S.I. 1992/352), regs. 1, **8(b)**
- F584** Sch. 2 Table 2 Item 4C inserted (3.1.1997) by The Road Vehicles (Construction and Use) (Amendment) (No. 8) Regulations 1996 (S.I. 1996/3133), regs. 1, **5**
- F585** Sch. 2 Table 2 Items 4D, 4E inserted (1.5.2002) by The Road Vehicles (Construction and Use) (Amendment) (No. 4) Regulations 2001 (S.I. 2001/3208), regs. 1(2), **11(3)**
- F586** Sch. 2 Table 2 Item 5A inserted (7.9.1989) by The Road Vehicles (Construction and Use) (Amendment) Regulations 1989 (S.I. 1989/1478), regs. 1, **5(2)**
- F587** Sch. 2 Table 2 Item 6A inserted (7.9.1989) by The Road Vehicles (Construction and Use) (Amendment) Regulations 1989 (S.I. 1989/1478), regs. 1, **5(3)**
- F588** Sch. 2 Table 2 items 6B-6D inserted (1.10.2001) by The Road Vehicles (Construction and Use) (Amendment) (No. 2) Regulations 2001 (S.I. 2001/1043), regs. 1, **8**
- F589** Sch. 2 Table 2 Item 6C inserted (1.2.1995) by The Road Vehicles (Construction and Use) (Amendment) (No.3) Regulations 1994 (S.I. 1994/3270), regs. 1, **5**
- F590** Sch. 2 Table 2 Items 13A, 13B inserted (1.1.1992) by The Road Vehicles (Construction and Use) (Amendment) (No. 5) Regulations 1991 (S.I. 1991/2710), regs. 1, **5(a)**
- F591** Sch. 2 Table 2 Item 13A inserted (2.11.1990) by The Road Vehicles (Construction and Use) (Amendment) (No. 4) Regulations 1990 (S.I. 1990/1981), regs. 1, **12(3)(c)**
- F592** Sch. 2 Table 2 Item 13A renumbered as Item 13C (1.1.1992) by The Road Vehicles (Construction and Use) (Amendment) (No. 5) Regulations 1991 (S.I. 1991/2710), regs. 1, **5(b)**
- F593** Sch. 2 Table 2 Item 21A inserted (1.1.1993) by The Road Vehicles (Construction and Use) (Amendment) (No. 7) Regulations 1992 (S.I. 1992/3088), regs. 1, **9(4)**
- F594** Sch. 2 Table 2 Item 21A(1) added (12.12.2005) by The Road Vehicles (Construction and Use) (Amendment)(No. 4) Regulations 2005 (S.I. 2005/3165), regs. 1, 6(2)
- F595** Sch. 2 Table 2 Item 21AA inserted (31.12.1992) by The Road Vehicles (Construction and Use) (Amendment) (No. 5) Regulations 1992 (S.I. 1992/2137), regs. 1, **4(2)**
- F596** Sch. 2 Table 2 Item 21AB inserted (1.10.1993) by The Road Vehicles (Construction and Use) (Amendment) (No. 2) Regulations 1993 (S.I. 1993/2199), regs. 1, **5(2)(a)**
- F597** Sch. 2 Table 2 Item 21BA inserted (1.10.1996) by The Road Vehicles (Construction and Use) (Amendment) (No. 5) Regulations 1996 (S.I. 1996/2329), regs. 1, **10(3)**
- F598** Sch. 2 Table 2 Item 21BB inserted (3.3.2009) by The Road Vehicles (Construction and Use) (Amendment) Regulations 2009 (S.I. 2009/142), regs. 1(2), **8(3)(a)**
- F599** Sch. 2 Table 2 Item 21A inserted (26.6.1990) by The Road Vehicles (Construction and Use) (Amendment) (No. 2) Regulations 1990 (S.I. 1990/1131), regs. 1, **6(2)**
- F600** Sch. 2 Table 2 Item 21A renumbered as Item 21B (1.1.1993) by The Road Vehicles (Construction and Use) (Amendment) (No. 7) Regulations 1992 (S.I. 1992/3088), regs. 1, **9(4)**
- F601** Sch. 2 Table 2 Item 21B inserted (2.11.1990) by The Road Vehicles (Construction and Use) (Amendment) (No. 4) Regulations 1990 (S.I. 1990/1981), regs. 1, **12(3)(d)**
- F602** Sch. 2 Table 2 Item 21B renumbered as Item 21C (1.1.1993) by The Road Vehicles (Construction and Use) (Amendment) (No. 7) Regulations 1992 (S.I. 1992/3088), regs. 1, **9(4)**
- F603** Sch. 2 Table 2 Items 22A, 22B inserted (1.8.2003) by The Road Vehicles (Construction and Use) (Amendment) (No. 2) Regulations 2003 (S.I. 2003/1690), regs. 1, **4**
- F604** Sch. 2 Table 2 Items 9A, 9B inserted (1.4.1992) by The Road Vehicles (Construction and Use) (Amendment) Regulations 1992 (S.I. 1992/352), regs. 1, **8(c)**
- F605** Sch. 2 Table 2 Items 9A, 9B renumbered as Items 23, 24 (1.1.1993) by The Road Vehicles (Construction and Use) (Amendment) (No. 4) Regulations 1992 (S.I. 1992/2016), regs. 1, **9(2)**

**F606** Sch. 2 Table 2 Items 25, 26 inserted (1.10.1993) by The Road Vehicles (Construction and Use) (Amendment) (No. 2) Regulations 1993 (S.I. 1993/2199), regs. 1, **5(2)(b)**

**F607** Sch. 2 Table 2 Items 27, 28 added (3.3.2009) by The Road Vehicles (Construction and Use) (Amendment) Regulations 2009 (S.I. 2009/142), regs. 1(2), **8(3)(b)**

**[F608] SCHEDULE 2A**

Regulation 3A

**VEHICLES FOR WHICH A MINISTER'S APPROVAL CERTIFICATE HAS BEEN  
ISSUED UNDER THE MOTOR VEHICLES (APPROVAL) REGULATIONS 1996**

**Textual Amendments**

**F608** Sch. 2A inserted (1.7.1997) by The Road Vehicles (Construction And Use) (Amendment) (No. 6) Regulations 1996 (S.I. 1996/3017), regs. 1, 6, **Sch.**

**PART I  
INTERPRETATION**

**General Interpretation**

**1.—(1)** In this Schedule—

“the Approval Regulations” means the Motor Vehicles (Approval) Regulations 1996;

“approval certificate” means a Minister’s approval certificate in the form prescribed by the Approval Regulations;

“approval date”, in relation to a vehicle in respect of which an approval certificate has been issued, is the date that the certificate was issued;

“goods vehicle approval certificate” means an approval certificate which appears to have been issued on the basis that the vehicle is a vehicle to which Part III of the Approval Regulations applies;

“passenger vehicle approval certificate” means an approval certificate which appears to have been issued on the basis that the vehicle is a vehicle to which Part II of the Approval Regulations applies.

**Interpretation of references to a vehicle complying with the approval requirements and to a vehicle exempt from the approval requirements**

**2.—(1)** Subject to paragraph 3, references in this Schedule to a vehicle complying with or being exempt from the approval requirements shall be construed in accordance with the following provisions of this paragraph.

(2) Subject to sub-paragraphs (4) and (5), a vehicle in respect of which a goods vehicle approval certificate has been issued shall be regarded as complying with or exempt from the approval requirements in relation to a specified subject matter if and only if it for the time being satisfies at least one of the conditions in regulation 6(5) of the Approval Regulations in relation to that subject matter.

**Status:** Point in time view as at 31/03/2009.

**Status:** This revised version has been created from an electronic version contributed by Westlaw which was originally derived from the printed publication. **Read more** (See end of Document for details)**Changes to legislation:** There are currently no known outstanding effects for the The Road Vehicles (Construction and Use) Regulations 1986. (See end of Document for details)

(3) Subject to sub-paragraphs (4) and (5), a vehicle in respect of which a passenger vehicle approval certificate has been issued shall be regarded as complying with or exempt from the approval requirements in relation to a specified subject matter if and only if it for the time being satisfies at least one of the conditions in regulation 4(5) of the Approval Regulations in relation to that subject matter.

(4) A vehicle in respect of which an approval certificate has been issued shall be regarded as neither complying with nor being exempt from the approval requirements in relation to any subject matter if—

- (a) the certificate is a goods vehicle approval certificate and the vehicle is not for the time being a vehicle to which Part III of the Approval Regulations applies; or
- (b) the certificate is a passenger vehicle approval certificate and the vehicle is not for the time being a vehicle to which Part II of the Approval Regulations applies.

(5) For the purposes of this paragraph, the Approval Regulations shall have effect with the omission of regulations 4(8) and 6(7).

## PART II

### MODIFICATION OF THE REGULATIONS

#### **Part exemption from regulation 32 (glazing)**

3. Regulation 32(2), (7) and (10) shall not apply to a vehicle in respect of which a passenger vehicle approval certificate has been issued, if it complies with or is exempt from the approval requirements relating to glazing.

#### **Exemption from regulation 33 (mirrors)**

4. Regulation 33 shall not apply to a vehicle in respect of which a passenger vehicle approval certificate has been issued, if it complies with or is exempt from the approval requirements relating to rear view mirrors.

#### **Exemption from regulation 35 (speedometers)**

5. Regulation 35 shall not apply to a vehicle in respect of which a passenger approval certificate has been issued, if it complies with or is exempt from the approval requirements relating to speedometers.

#### **Exemption from regulation 39(2)(c)(i) (fuel tanks to be made of metal)**

6. Regulation 39(2)(c)(i) shall not apply to a vehicle in respect of which either a passenger vehicle approval certificate or a goods vehicle approval certificate has been issued, if it complies with the approval requirements relating to general vehicle construction.

#### **Exemption from regulation 46 (seat belt anchorages)**

7. Regulation 46 shall not apply to a vehicle in respect of which a passenger vehicle approval certificate has been issued, if it complies with or is exempt from the approval requirements relating to anchorage points.



**Status:** Point in time view as at 31/03/2009.

**Status:** This revised version has been created from an electronic version contributed by Westlaw which was originally derived from the printed publication. **Read more** (See end of Document for details)**Changes to legislation:** There are currently no known outstanding effects for the The Road Vehicles (Construction and Use) Regulations 1986. (See end of Document for details)

### Part exemption from regulation 47 (seat belts)

8. Regulation 47, so far as it relates to seat belts for adults, shall not apply to a vehicle in respect of which a passenger vehicle approval certificate has been issued, if it complies with or is exempt from the approval requirements relating to seat belts (including the requirements relating to the installation of seat belts).

### Modifications to regulation 61 (emissions)

9.—(1) Regulation 61 shall have effect with the following modifications in relation to a vehicle in respect of which there has been issued an approval certificate containing the letter “A” pursuant to regulation 12(2)(c) of the Approval Regulations.

(2) For the purposes of paragraphs (3A), (7), (8) and (9), the date of first use of the vehicle shall be regarded as being 1st January immediately preceding the date of manufacture of the engine by which it is propelled.

However, the date on which the vehicle is first used shall not, by virtue of this paragraph, be regarded in any circumstances as being later than the date on which it would otherwise have been regarded as being first used had this paragraph been omitted.

(3) Paragraphs 10(A) and 10(AA) shall not apply to the vehicle if it complies with or is exempt from the approval requirements relating to exhaust emissions.

[  
F609] 9A. Paragraphs (10A), (10AA) and (10BA) of regulation 61 shall not apply to a vehicle in respect of which either a passenger vehicle approval certificate or a goods vehicle approval certificate has been issued, if it complies with, or is exempt from, the approval requirements relating to exhaust or smoke emissions.

#### Textual Amendments

F609 Sch. 2A paras. 9A, 9B inserted (1.1.2001) by [The Road Vehicles \(Construction and Use\) \(Amendment\) \(No. 3\) Regulations 2000 \(S.I. 2000/3197\)](#), regs. 1, 7

### Modifications to regulation 61A (emissions)

9B.—(1) Regulation 61A shall not apply to a vehicle in respect of which either a passenger vehicle approval certificate or a goods vehicle approval certificate has been issued, if it complies with or is exempt from the approval requirements relating to exhaust or smoke emissions.

(2) Regulation 61A shall have effect with the following modifications in relation to a vehicle in respect of which there has been issued an approval certificate containing the letter “A” pursuant to regulation 12(2)(c) of the Approval Regulations.

(3) For the purposes of paragraphs (2) and (3) of regulation 61A, the date as is specified (as defined in regulation 61A) shall be regarded as being the 1st January immediately preceding the date of manufacture of the engine by which the vehicle is propelled; provided that the date as is specified shall not in any circumstances be regarded as being later than the date on which the motor vehicle would otherwise have been regarded as being first used.]

#### Textual Amendments

F609 Sch. 2A paras. 9A, 9B inserted (1.1.2001) by [The Road Vehicles \(Construction and Use\) \(Amendment\) \(No. 3\) Regulations 2000 \(S.I. 2000/3197\)](#), regs. 1, 7

**Status:** Point in time view as at 31/03/2009.

**Status:** This revised version has been created from an electronic version contributed by Westlaw which was originally derived from the printed publication. **Read more** (See end of Document for details)**Changes to legislation:** There are currently no known outstanding effects for the The Road Vehicles (Construction and Use) Regulations 1986. (See end of Document for details)

**Modification to regulation 67 (vehicle identification numbers)**

10. Regulation 67 shall not apply to a vehicle in respect of which an approval certificate has been issued if—

- (a) the vehicle is equipped with a plate which is in a conspicuous and readily accessible position, is affixed to a vehicle part which is not normally subject to replacement and shows clearly and indelibly the identification number shown on the certificate and the name of the manufacturer; and
- (b) that number is marked on the chassis, frame or other similar structure, on the offside of the vehicle, in a clearly visible and accessible position, and by a method such as hammering or stamping, in such a way that it cannot be obliterated or deteriorate.]

SCHEDULE 3

(see regulation 16)

BRAKING REQUIREMENTS

1. The braking requirements referred to in regulation 16(4) are set out in the Table and are to be interpreted in accordance with paragraphs 2 to 5 of this Schedule.

**TABLE**

(Schedule 3)

<i>Number</i>	<i>Requirement</i>
1	<p>The vehicle shall be equipped with—</p> <p>(a) one efficient braking system having two means of operation;</p> <p>(b) one efficient split braking system having one means of operation; or</p> <p>(c) two efficient braking systems each having a separate means of operation.</p> <p>and in the case of a vehicle first used on or after 1st January 1968, no account shall be taken of a multi-pull means of operation unless, at first application, it operates a hydraulic, electric or pneumatic device which causes the application of brakes with total braking efficiency not less than 25%.</p>
2	<p>The vehicle shall be equipped with—</p> <p>(a) one efficient braking system having two means of operation; or</p> <p>(b) two efficient braking systems each having a separate means of operation.</p>
3	<p>The vehicle shall be equipped with an efficient braking system.</p>
4	<p>The braking system shall be so designed that in the event of failure of any part (other than a fixed member or a brake shoe anchor pin) through or by means of which the force necessary to apply the brakes is transmitted, there shall still be available for application by the driver brakes sufficient under the most adverse conditions to bring the vehicle to rest within a reasonable distance. The brakes so available shall be applied to—</p>

**Status:** Point in time view as at 31/03/2009.

**Status:** This revised version has been created from an electronic version contributed by Westlaw which was originally derived from the printed publication. **Read more** (See end of Document for details)**Changes to legislation:** There are currently no known outstanding effects for the The Road Vehicles (Construction and Use) Regulations 1986. (See end of Document for details)

<i>Number</i>	<i>Requirement</i>
	<p>(a) in the case of a track-laying vehicle, one track on each side of the vehicle;</p> <p>(b) in the case of a wheeled motor vehicle, one wheel if the vehicle has 3 wheels and otherwise to at least half the wheels; and</p> <p>(c) in the case of a wheeled trailer, at least one wheel if it has only 2 wheels and otherwise at least 2 wheels.</p> <p>This requirement applies to the braking systems of both a trailer and the vehicle by which it is being drawn except that if the drawing vehicle complies with regulation 15, [F610Community Directive [F61179/489, 85/647, 88/194, 91/422 or 98/12 or ECE Regulation 13.03, 13.04, 13.05, 13.06, 13.07, 13.08 or 13.09]], the requirements applies only to the braking system of the drawing vehicle. It does not apply to vehicles having split braking systems (which are subject to regulation 18(3)(b)) or to road rollers. (The expressions `part' and `half the wheels' are to be interpreted in accordance with paragraphs (3) and (4) respectively).</p>
5	The braking system shall be so designed and constructed that, in the event of the failure of any part thereof, there shall still be available for application by the driver a brake sufficient under the most adverse conditions to bring the vehicle to rest within a reasonable distance.
6	<p>The braking system of a vehicle, when drawing a trailer which complies with regulation 15, [F610Community Directive [F61279/489, 85/647, 88/194, 91/422 or 98/12 or ECE Regulation 13.03, 13.04, 13.05, 13.06, 13.07, 13.08 or 13.09]], shall be so constructed that, in the event of a failure of any part (other than a fixed member or brake shoe anchor pin) of the service braking system of the drawing vehicle (excluding the means of operation of a split braking system) the driver can still apply brakes to at least one wheel of the trailer, if it has only 2 wheels, and otherwise to at least 2 wheels, by using the secondary braking system of the drawing vehicle.</p> <p>(The expression “part” is to be interpreted in accordance with paragraph 3).</p>
7	The application of any means of operation of a braking system shall not affect or operate the pedal or hand lever of any other means of operation.
8	The braking system shall not be rendered ineffective by the non-rotation of the engine of the vehicle or, in the case of a trailer, the engine of the drawing vehicle (steam-propelled vehicles, other than locomotives and buses, are excluded from this requirement).
9	<p>At least one means of operation shall be capable of causing brakes to be applied directly, and not through the transmission gear, to at least half the wheels of the vehicle. This requirement does not apply to a works truck with an unladen weight not exceeding 7370 kg, or to an industrial tractor; and it does not apply to a vehicle with more than 4 wheels if—</p> <p>(a) the drive is transmitted to all wheels other than the steering wheels without the interposition of a differential driving gear or similar mechanism between the axles carrying the driving wheels; and</p>

**Status:** Point in time view as at 31/03/2009.

**Status:** This revised version has been created from an electronic version contributed by Westlaw which was originally derived from the printed publication. **Read more** (See end of Document for details)**Changes to legislation:** There are currently no known outstanding effects for the The Road Vehicles (Construction and Use) Regulations 1986. (See end of Document for details)

Number	Requirement
	(b) the brakes applied by one means of operation apply directly to 2 driving wheels on opposite sides of the vehicle; and
	(c) the brakes applied by another means of operation act directly on all the other driving wheels.
	(The expression “half the wheels” is to be interpreted in accordance with paragraph (4)).
10	The brakes of a trailer shall come into operation automatically on its overrun or, in the case of a track-laying trailer drawn by a vehicle having steerable wheels at the front or a wheeled trailer, the driver of, or some other person on, the drawing vehicle or on the trailer shall be able to apply the brakes on the trailer.
11	The brakes of a trailer shall come into operation automatically on its overrun or the driver of the drawing vehicle shall be able to apply brakes to all the wheels of the trailer, using the means of operation which applies the service brakes of the drawing vehicle.
12	The brakes of the vehicle shall apply to all wheels other than the steering wheels.
13	The brakes of the vehicle shall apply to at least 2 wheels.
14	The brakes of the vehicle shall apply in the case of a wheeled vehicle to at least 2 wheels if the vehicle has no more than 4 wheels and to at least half the wheels if the vehicle has more than 4 wheels; and in the case of a track-laying vehicle to all the tracks.
15	The brakes shall apply to all the wheels.
16	<p>The parking brake shall be so designed and constructed that—</p> <p>(a) in the case of a wheeled heavy motor car or motor car, its means of operation is independent of the means of operation of any split braking system with which the vehicle is fitted;</p> <p>(b) in the case of a motor vehicle other than a motor cycle or an invalid carriage, either—</p> <p>(i) it is capable of being applied by direct mechanical action without the intervention of any hydraulic, electric or pneumatic device; or</p> <p>(ii) the vehicle complies with requirement 15; and</p> <p>(c) it can at all times when the vehicle is not being driven or is left unattended be set so as—</p> <p>(i) in the case of a track-laying vehicle, to lock the tracks; and</p> <p>(ii) in the case of a wheeled vehicle, to prevent the rotation of at least one wheel in the case of a three wheeled vehicle and at least two wheels in the case of a vehicle with more than three wheels.</p>
17	The parking brake shall be capable of being set so as effectively to prevent two at least of the wheels from revolving when the trailer is not being drawn.
18	<p>The parking brake shall be so designed and constructed that—</p> <p>(a) in the case of a motor vehicle, its means of operation (whether multi-pull or not) is independent of the means of operation of any braking system</p>

**Status:** Point in time view as at 31/03/2009.

**Status:** This revised version has been created from an electronic version contributed by Westlaw which was originally derived from the printed publication. **Read more** (See end of Document for details)**Changes to legislation:** There are currently no known outstanding effects for the The Road Vehicles (Construction and Use) Regulations 1986. (See end of Document for details)

<i>Number</i>	<i>Requirement</i>
	required by regulation 18 to have a total braking efficiency of not less than 50%; and
	(b) in the case of a trailer, its brakes can be applied and released by a person standing on the ground by a means of operation fitted to the trailer; and
	(c) in either case, its braking force, when the vehicle is not being driven or is left unattended (and in the case of a trailer, whether the braking force is applied by the driver using the service brakes of the drawing vehicle or by a person standing on the ground in the manner indicated in sub-paragraph (b)) can at all times be maintained in operation by direct mechanical action without the intervention of any hydraulic, electric or pneumatic device and, when so maintained, can hold the vehicle stationary on a gradient of at least 16% without the assistance of stored energy.

#### Textual Amendments

**F610** Words in Sch. 3 Table substituted (2.11.1990) by The Road Vehicles (Construction and Use) (Amendment) (No. 4) Regulations 1990 (S.I. 1990/1981), regs. 1, **6(d)**

**F611** Words in Sch. 3 Table Item 4 substituted (1.5.2002) by The Road Vehicles (Construction and Use) (Amendment) (No. 4) Regulations 2001 (S.I. 2001/3208), regs. 1(2), **12(3)**

**F612** Words in Sch. 3 Table Item 6 substituted (1.5.2002) by The Road Vehicles (Construction and Use) (Amendment) (No. 4) Regulations 2001 (S.I. 2001/3208), regs. 1(2), **12(2)**

#### Commencement Information

**I104** Sch. 3 para. 1 in force at 11.8.1986, see **reg. 1**

2. For the purposes of requirement 3 in the Table, in the case of a motor car or heavy motor car propelled by steam and not used as a bus, the engine shall be deemed to be an efficient braking system with one means of operation if the engine is capable of being reversed and, in the case of a vehicle first used on or after 1st January 1927, is incapable of being disconnected from any of the driving wheels of the vehicle except by the sustained effort of the driver.

#### Commencement Information

**I105** Sch. 3 para. 2 in force at 11.8.1986, see **reg. 1**

3. For the purpose of requirements 4 and 6 in the Table, in the case of a wheeled motor car and of a vehicle first used on or after 1st October 1938 which is a locomotive, a motor tractor, a heavy motor car or a track-laying motor car, every moving shaft which is connected to or supports any part of a braking system shall be deemed to be part of the system.

#### Commencement Information

**I106** Sch. 3 para. 3 in force at 11.8.1986, see **reg. 1**

4. For the purpose of [<sup>F613</sup>requirements 4, 9 and 14] in the Table, in determining whether brakes apply to at least half the wheels of a vehicle, not more than one front wheel shall be treated as a wheel to which brakes apply unless the vehicle is—

- (a) a locomotive or motor tractor with more than 4 wheels;

**Status:** Point in time view as at 31/03/2009.

**Status:** This revised version has been created from an electronic version contributed by Westlaw which was originally derived from the printed publication. **Read more** (See end of Document for details)**Changes to legislation:** There are currently no known outstanding effects for the The Road Vehicles (Construction and Use) Regulations 1986. (See end of Document for details)

- (b) a heavy motor car or motor car first used before 1st October 1938;
- (c) a motor car with an unladen weight not exceeding 1020 kg;
- (d) a motor car which is a passenger vehicle but is not a bus;
- (e) a works truck;
- (f) a heavy motor car or motor car with more than 3 wheels which is equipped in respect of all its wheels with brakes which are operated by one means of operation; or
- (g) a track-laying vehicle.

#### Textual Amendments

**F613** Words in [Sch. 3 para. 4](#) substituted (6.5.1987) by [The Road Vehicles \(Construction and Use\) \(Amendment\) Regulations 1987 \(S.I. 1987/676\)](#), regs. 1(2), **15(6)**

#### Commencement Information

**I107** [Sch. 3 para. 4](#) in force at 11.8.1986, see [reg. 1](#)

5. In this Schedule a “multi-pull means of operation” means a device forming part of a braking system which causes the muscular energy of the driver to apply the brakes of that system progressively as a result of successive applications of that device by the driver.

#### Commencement Information

**I108** [Sch. 3 para. 5](#) in force at 11.8.1986, see [reg. 1](#)

## [<sup>F614</sup>SCHEDULE 3A

(see regulations 39A and 39B)

### EXCLUSION OF CERTAIN VEHICLES FROM THE APPLICATION OF REGULATION 39A

#### Textual Amendments

**F614** [Sch. 3A](#) inserted (1.10.1988) by [The Road Vehicles \(Construction and Use\) \(Amendment\) \(No. 6\) Regulations 1988 \(S.I. 1988/1524\)](#), reg. 1, [Sch.](#)

## PART I

### 1.—(1) In this Part —

“EEC type approval certificate” means a certificate issued by a member state of the European Economic Community in accordance with Community Directive 70/220 as originally made or with any amendments which have from time to time been made before 5th September 1988;

“engine capacity” means in the case of a reciprocating engine, the nominal swept volume and, in the case of a rotary engine, double the nominal swept volume;

<sup>F615</sup> ...

“relevant authority” means —

**Status:** Point in time view as at 31/03/2009.

**Status:** This revised version has been created from an electronic version contributed by Westlaw which was originally derived from the printed publication. **Read more** (See end of Document for details)**Changes to legislation:** There are currently no known outstanding effects for the The Road Vehicles (Construction and Use) Regulations 1986. (See end of Document for details)

- (a) in relation to an EEC type approval certificate issued by the United Kingdom, the Secretary of State, and
- (b) in relation to an EEC type approval certificate issued by any other member state of the European Economic Community, the authority having power under the law of that state to issue that certificate.

(2) The reference in this Schedule to a M1 category vehicle is a reference to a vehicle described as M1 in Council Directive 70/156/EEC of 6th February 1970 as amended at 5th September 1988.

**Textual Amendments**

**F615** Words in Sch. 3A para. 1 omitted (26.6.1990) by virtue of [The Road Vehicles \(Construction and Use\) \(Amendment\) \(No. 2\) Regulations 1990 \(S.I. 1990/1131\)](#), regs. 1, **6(3)(a)**

<sup>F616</sup>**2.** A vehicle of a description specified in column 2 of the Table below is excluded from the application of regulation 39A if it is first used before the date specified in column 3 and the conditions specified in paragraph 3 are satisfied in respect to it on that date.

**Textual Amendments**

**F616** Sch. 3A para. 3 renumbered as Sch. 3A para. 2 (26.6.1990) by [The Road Vehicles \(Construction and Use\) \(Amendment\) \(No. 2\) Regulations 1990 \(S.I. 1990/1131\)](#), regs. 1, **6(3)(b)**

<sup>F617</sup>**3.** The conditions referred to in paragraph 2 are —

- (a) that the vehicle is a model in relation to which there is in force an EEC type approval certificate issued before 1st October 1989;
- (b) that the manufacturer of the vehicle has supplied to the relevant authority which issued the EEC type approval certificate, a certificate stating that adapting vehicles of that model to the fuel requirements specified in the Annexes to Community Directive 88/76 would entail a change in material specification of the inlet or exhaust valve seats or a reduction in the compression ratio or an increase in the engine capacity to compensate for loss of power; and
- (c) that the relevant authority has accepted the certificate referred to in sub-paragraph (b).

**Table**

Item	Description of vehicle	Date before which vehicle must be first used
(1)	(2)	(3)
1.	Vehicles with an engine capacity of less than 1400cc.	1.4.92
2.	Vehicles with an engine capacity of not less than 1400cc and not more than 2000cc.	1.4.94
3.	M1 category vehicles with an engine capacity of more than 2000cc and which —	1.4.93

**Status:** Point in time view as at 31/03/2009.

**Status:** This revised version has been created from an electronic version contributed by Westlaw which was originally derived from the printed publication. **Read more** (See end of Document for details)**Changes to legislation:** There are currently no known outstanding effects for the The Road Vehicles (Construction and Use) Regulations 1986. (See end of Document for details)

Item	Description of vehicle	Date before which vehicle must be first used
(1)	(2)	(3)
	(a) are constructed or adapted to carry not more than 5 passengers excluding the driver, or (b) have a maximum gross weight of not more than 2500kg. not being in either case, an off-road vehicle.	

**Textual Amendments**

**F617** Sch. 3A para. 4 renumbered as Sch. 3A para. 3 (26.6.1990) by [The Road Vehicles \(Construction and Use\) \(Amendment\) \(No. 2\) Regulations 1990 \(S.I. 1990/1131\)](#), regs. 1, **6(3)(b)**



## PART II

### SYMBOL INDICATING THAT VEHICLE CAN RUN ON UNLEADED PETROL<sup>1</sup>

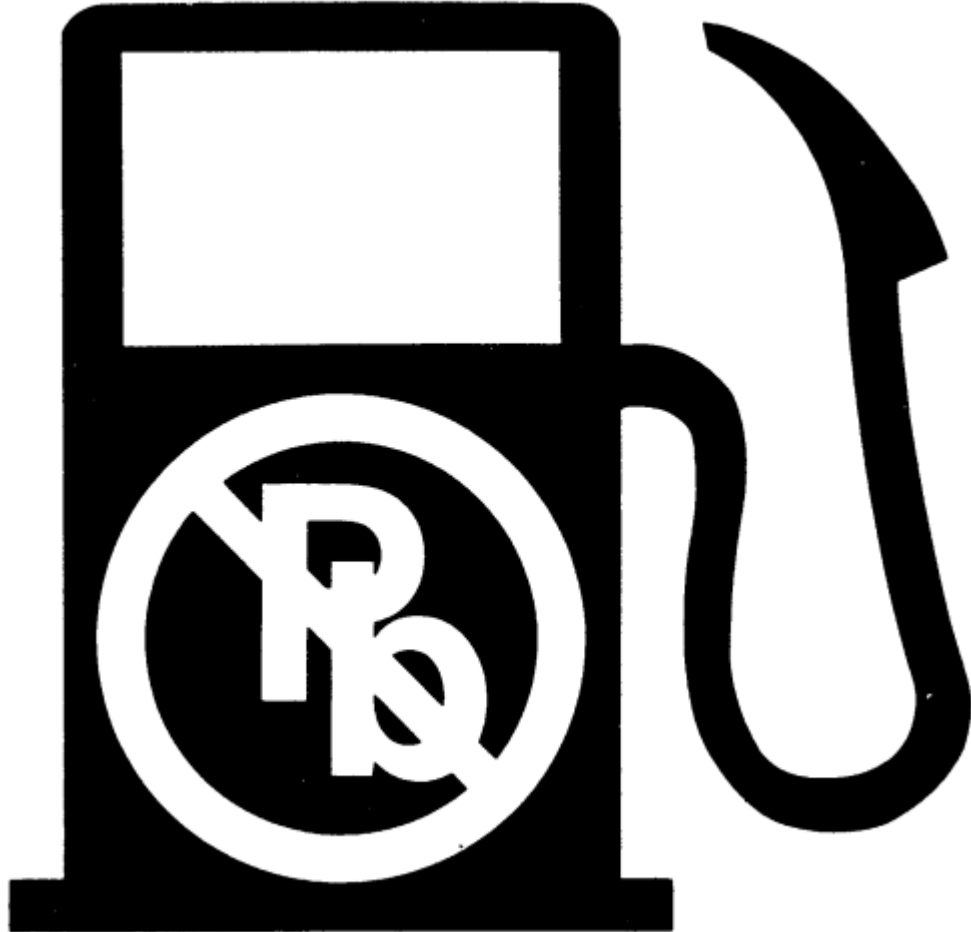

<sup>1</sup>F618 SCHEDULE 3B

Regulation 36C

#### AUTHORISED SEALERS

##### Textual Amendments

**F618** Sch. 3B inserted (1.8.1992) by [The Road Vehicles \(Construction and Use\) \(Amendment\) \(No. 2\) Regulations 1992 \(S.I. 1992/422\)](#), regs. 1(2), 5(2), **Sch.**

**Status:** Point in time view as at 31/03/2009.

**Status:** This revised version has been created from an electronic version contributed by Westlaw which was originally derived from the printed publication. **Read more** (See end of Document for details)**Changes to legislation:** There are currently no known outstanding effects for the The Road Vehicles (Construction and Use) Regulations 1986. (See end of Document for details)

## PART I

### general

1. The Secretary of State may authorise—
  - (a) an individual proposing to seal speed limiters other than on behalf of another person;
  - (b) a firm; or
  - (c) a corporation; and a person or body so authorised is referred to in this Schedule as an “authorised sealer”.
2. An authorised sealer shall comply with the conditions set out in Part II of this Schedule and with such other conditions as may from time to time be imposed by the Secretary of State.
3. An authorised sealer may charge for sealing a speed limiter.
4. The Secretary of State may at any time withdraw an authorisation granted under this Schedule.
- 5.—(1) An authorisation under this Schedule in respect of an individual shall terminate if—
  - (a) he dies;
  - (b) is adjudged bankrupt or, in Scotland, has his estate sequestrated; or
  - (c) becomes a <sup>F619</sup>person who lacks capacity (within the meaning of the Mental Capacity Act 2005 (c.9)) to carry on the activities covered by the authorisation] or, in Scotland, becomes incapable of managing his own affairs.

(2) An authorisation under this Schedule in respect of a firm shall terminate if the firm is dissolved or if all the partners are adjudged bankrupt.

(3) An authorisation under this Schedule in respect of a company shall terminate if—

  - (a) the company goes into liquidation or <sup>F620</sup>enters administration];
  - (b) a receiver or manager of the trade or business of the company is appointed; or
  - (c) possession is taken by or on behalf of the holders of any debenture secured by a floating charge, or any property of the company comprised in or subject to the charge, occurs.

#### Textual Amendments

**F619** Words in Sch. 3B para. 5(1)(c) substituted (E.W.) (1.10.2007) by The Mental Capacity Act 2005 (Transitional and Consequential Provisions) Order 2007 (S.I. 2007/1898), art. 1, Sch. 1 para. 10

**F620** Words in Sch. 3B para. 5(3)(a) substituted (15.9.2003) by The Enterprise Act 2002 (Insolvency) Order 2003 (S.I. 2003/2096), art. 1(1), Sch. para. 43 (with art. 6)

## PART II

### the conditions

- <sup>F621</sup>6. An authorised sealer shall not—
  - (a) seal a speed limiter fitted to a vehicle to which regulation 36A applies unless he is satisfied that the speed limiter fulfils the requirements of—
    - (i) paragraph (5)(b);
    - (ii) paragraph (6), (7) or (7A); and
    - (iii) paragraph (8) or (9),

**Status:** This revised version has been created from an electronic version contributed by Westlaw which was originally derived from the printed publication. **Read more** (See end of Document for details)**Changes to legislation:** There are currently no known outstanding effects for the The Road Vehicles (Construction and Use) Regulations 1986. (See end of Document for details)

of that regulation, or

- (b) seal a speed limiter fitted to a vehicle to which regulation 36B applies unless he is satisfied that the speed limiter fulfils the requirements of—
- (i) paragraph (7)(b);
  - (ii) paragraph (8) or (9); and
  - (iii) paragraph (10) or (11),
- of that regulation.]

**Textual Amendments**

**F621** Sch. 3B para. 6 substituted (1.12.2007) by [The Road Vehicles \(Construction and Use\) \(Amendment\) \(No. 3\) Regulations 2007 \(S.I. 2007/3132\)](#), regs. 1(1), 4

7. When sealing a speed limiter fitted to a vehicle to which regulation 36A applies, an authorised sealer shall do so in such a manner that the speed limiter fulfils the requirements of [<sup>F622</sup>paragraph (5) (a)] of that regulation.

**Textual Amendments**

**F622** Words in Sch. 3B para. 7 substituted (1.9.2003) by [The Road Vehicles \(Construction and Use\) \(Amendment\) \(No. 3\) Regulations 2003 \(S.I. 2003/1946\)](#), regs. 1, 6(4)

8. When sealing a speed limiter fitted to a vehicle to which regulation 36B applies, an authorised sealer shall do so in such a manner that the speed limiter fulfils the requirements of [<sup>F623</sup>paragraph (7) (a)] of that regulation.

**Textual Amendments**

**F623** Words in Sch. 3B para. 8 substituted (1.9.2003) by [The Road Vehicles \(Construction and Use\) \(Amendment\) \(No. 3\) Regulations 2003 \(S.I. 2003/1946\)](#), regs. 1, 6(5)

9. When an authorised sealer has sealed a speed limiter fitted to a vehicle to which section 36A applies he shall supply the owner with a plate which fulfils the requirements of regulation 70A.

10. When an authorised sealer has sealed a speed limiter fitted to a vehicle to which section 36B applies he shall supply the owner with a plate which fulfils the requirements of [<sup>F624</sup>regulation 70A]]

**Textual Amendments**

**F624** Words in Sch. 3B para. 10 substituted (1.9.2003) by [The Road Vehicles \(Construction and Use\) \(Amendment\) \(No. 3\) Regulations 2003 \(S.I. 2003/1946\)](#), regs. 1, 6(6)

**Status:** Point in time view as at 31/03/2009.

**Status:** This revised version has been created from an electronic version contributed by Westlaw which was originally derived from the printed publication. **Read more** (See end of Document for details)**Changes to legislation:** There are currently no known outstanding effects for the The Road Vehicles (Construction and Use) Regulations 1986. (See end of Document for details)

## SCHEDULE 4

(see regulation 40)

### GAS CONTAINERS

#### PART I

##### Definitions relating to gas containers

1. In this Schedule, unless the context otherwise requires, the following expressions have the meanings hereby assigned to them respectively, that is to say—

“gas container” means a container fitted to a motor vehicle or a trailer and intended for the storage of gaseous fuel for the purpose of the propulsion of the vehicle or the drawing vehicle as the case may be;

“gas cylinder” means a container fitted to a motor vehicle or a trailer and intended for the storage of compressed gas for the purpose of the propulsion of the vehicle or the drawing vehicle as the case may be;

“compressed gas” means gaseous fuel under a pressure exceeding 1.0325 bar above atmospheric pressure;

“pipe line” means all pipes connecting a gas container or containers—

- (a) to the engine or the mixing device for the supply of a mixture of gas and air to the engine; and
- (b) to the filling point on the vehicle;

“pressure pipe line” means any part of a pipe line intended for the conveyance of compressed gas; and

“reducing valve” means an apparatus which automatically reduces the pressure of the gas passing through it.

##### Commencement Information

**I109** Sch. 4 Pt. I para. 1 in force at 11.8.1986, see [reg. 1](#)

##### Gas containers

2. Every gas container shall—

- (a) be securely attached to the vehicle in such manner as not to be liable to displacement or damage due to vibration or other cause; and
- (b) be so placed or insulated as not to be adversely affected by the heat from the exhaust system.

##### Commencement Information

**I110** Sch. 4 Pt. I para. 2 in force at 11.8.1986, see [reg. 1](#)

##### Pipe lines

3.—(1) Every pipe line shall be supported in such manner as to be protected from excessive vibration and strain.

(2) No part of a pipe line shall be in such a position that it may be subjected to undue heat from the exhaust system.

(3) Every pressure pipe line shall be made of steel solid drawn.

(4) The maximum unsupported length of a pressure pipe line shall not exceed 920 mm.

**Commencement Information**

**I111** Sch. 4 Pt. I para. 3 in force at 11.8.1986, see [reg. 1](#)

**Unions**

4.—(1) Every union shall be so constructed and fitted that it will—

(a) not be liable to work loose or develop leakage when in use; and

(b) be readily accessible for inspection and adjustment.

(2) No union on a pressure pipe line or on a gas cylinder shall contain a joint other than a metal to metal joint.

**Commencement Information**

**I112** Sch. 4 Pt. I para. 4 in force at 11.8.1986, see [reg. 1](#)

**Reducing valves**

5. Every reducing valve shall be—

(a) so fitted as to be readily accessible; and

(b) so constructed that there can be no escape of gas when the engine is not running.

**Commencement Information**

**I113** Sch. 4 Pt. I para. 5 in force at 11.8.1986, see [reg. 1](#)

**Valves and cocks**

6.—(1) Every valve or cock intended to be subjected to a pressure exceeding 6.8948 bar shall be of forged steel or of brass or bronze complying with the specification contained in Part II of this Schedule.

(2) A valve or cock shall be fitted to the pipe line to enable the supply of gas from the container or containers to the mixing device to be shut off.

(a) (3) (a) In the case of a pressure pipe line the valve or cock shall be placed between the reducing valve and the container or containers and shall be readily visible and accessible from the outside of the vehicle and a notice indicating its position and method of operation shall be affixed in a conspicuous position on the outside of the vehicle carrying the gas container or containers.

(b) In other cases, if the valve or cock is not so visible and accessible as aforesaid, a notice indicating its position shall be affixed in a conspicuous position on the outside of the vehicle carrying the container or containers.

**Status:** Point in time view as at 31/03/2009.

**Status:** This revised version has been created from an electronic version contributed by Westlaw which was originally derived from the printed publication. **Read more** (See end of Document for details)**Changes to legislation:** There are currently no known outstanding effects for the The Road Vehicles (Construction and Use) Regulations 1986. (See end of Document for details)

**Commencement Information**

**I114** Sch. 4 Pt. 1 para. 6 in force at 11.8.1986, see [reg. 1](#)

**Pressure gauges**

7. Every pressure gauge connected to a pressure pipe line shall be so constructed as not to be liable to deterioration under the action of the particular gases employed and shall be so constructed and fitted that—

- (a) in the event of failure of such pressure gauge no gas can escape into any part of the vehicle;
- (b) it is not possible owing to leakage of gas into the casing of the pressure gauge for pressure to increase therein to such extent as to be liable to cause a breakage of the glass thereof; and
- (c) in the event of failure of such pressure gauge the supply of gas thereto may be readily cut off.

**Commencement Information**

**I115** Sch. 4 Pt. 1 para. 7 in force at 11.8.1986, see [reg. 1](#)

**Charging connections**

8.—(1) Every connection for charging a gas container shall be outside the vehicle and in the case of a public service vehicle no such connection shall be within 610 mm of any entrance or exit.

(2) An efficient shut-off valve shall be fitted as near as practicable to the filling point.

Provided that in cases where compressed gas is not used a cock or an efficient non-return valve may be fitted in lieu thereof.

(3) Where compressed gas is used an additional emergency shut-off valve shall be fitted adjacent to the valve referred to in sub-paragraph (2) of this paragraph.

(4) A cap shall be fitted to the gas filling point on the vehicle and where compressed gas is used this cap shall be made of steel with a metal to metal joint.

**Commencement Information**

**I116** Sch. 4 Pt. 1 para. 8 in force at 11.8.1986, see [reg. 1](#)

**Trailers**

9.—(1) Where a trailer is used for the carriage of a gas cylinder, a reducing valve shall be fitted on the trailer.

(2) No pipe used for conveying gas from a trailer to the engine of a vehicle shall contain compressed gas.

**Commencement Information**

**I117** Sch. 4 Pt. 1 para. 9 in force at 11.8.1986, see [reg. 1](#)

### Construction, etc., of system

10. Every part of a gas container propulsion system shall be—
- (a) so placed or protected as not to be exposed to accidental damage and shall be soundly and properly constructed of suitable and well-finished materials capable of withstanding the loads and stresses likely to be met with in operation and shall be maintained in an efficient, safe and clean condition; and
  - (b) so designed and constructed that leakage of gas is not likely to occur under normal working conditions, whether or not the engine is running.

#### Commencement Information

I118 Sch. 4 Pt. I para. 10 in force at 11.8.1986, see [reg. 1](#)

## PART II

### SPECIFICATION FOR BRASS OR BRONZE VALVES

#### Manufacture of valves

1. The stamping or pressing from which each valve is manufactured shall be made from bars produced by (a) extrusion, (b) rolling, (c) forging, (d) extrusion and drawing, or (e) rolling and drawing.

#### Commencement Information

I119 Sch. 4 Pt. II para. 1 in force at 11.8.1986, see [reg. 1](#)

#### Heat treatment

2. Each stamping or pressing shall be heat treated so as to produce an equiaxed microstructure in the material.

#### Commencement Information

I120 Sch. 4 Pt. II para. 2 in force at 11.8.1986, see [reg. 1](#)

#### Freedom from defects

3. All stampings or pressings and the bars from which they are made shall be free from cracks, laminations, hard spots, segregated materials and variations in composition.

#### Commencement Information

I121 Sch. 4 Pt. II para. 3 in force at 11.8.1986, see [reg. 1](#)

**Status:** Point in time view as at 31/03/2009.

**Status:** This revised version has been created from an electronic version contributed by Westlaw which was originally derived from the printed publication. **Read more** (See end of Document for details)**Changes to legislation:** There are currently no known outstanding effects for the The Road Vehicles (Construction and Use) Regulations 1986. (See end of Document for details)

## Tensile test

4. Tensile tests shall be made on samples of stampings or pressings taken at random from any consignment. The result of the tensile test shall conform to the following conditions—

Yield Stress.—Not less than 231.6 N/mm<sup>2</sup>.

Ultimate Tensile Stress.—Not less than 463.3 N/mm<sup>2</sup>.

Elongation on 50 mm gauge length.—Not less than 25%.

*Note.*—When the gauge length is less than 50 mm the required elongation shall be proportionately reduced.

The fractured test piece shall be free from piping and other defects (see paragraph 3 of this Part of this Schedule).

### Commencement Information

**I122** Sch. 4 Pt. II para. 4 in force at 11.8.1986, see [reg. 1](#)

## SCHEDULE 5

(see regulations 40 and 96)

### GAS SYSTEMS

#### Definitions

1. In this Schedule—

“check valve” means a device which permits the flow of gas in one direction and prevents the flow of gas in the opposite direction;

“design pressure” means the pressure which a part of a gas system has been designed and constructed safely to withstand;

“double-check valve” means a device which consists of two check valves in series and which permits the flow of gas in one direction and prevents the flow of gas in the opposite direction;

[<sup>F625</sup>“electrically operated valve” means a device which is electrically operated and opens when the ignition is switched on and closes when the ignition is switched off or the power is otherwise cut off;]

“excess flow valve” means a device which automatically and instantaneously reduces to a minimum the flow of gas through the valve when the flow rate exceeds a set value;

“fixed gas container” means a gas container which is attached to a vehicle permanently and in such a manner that the container can be filled without being moved;

“gas container” means any container, not being a container for the carriage of gas as goods, which is fitted to or carried on a motor vehicle or trailer and is intended for the storage of gas for either—

- (a) the propulsion of the motor vehicle, or
- (b) the operation of a gas-fired appliance;

“high pressure” means a pressure exceeding 1.0325 bar absolute;

“high pressure pipeline” means a pipeline intended to contain gas at high pressure;



“pipeline” means any pipe or passage connecting any two parts of a gas propulsion system of a vehicle or of a gas-fired appliance supply system on a vehicle or any two points on the same part of any such system;

“portable gas container” means a gas container which may be attached to a vehicle but which can readily be removed;

“pressure relief valve” means a device which opens automatically when the pressure in the part of the gas system to which it is fitted exceeds a set value, reaches its maximum flow capacity when the set valve is exceeded by 10% and closes automatically when the pressure falls below a set value ; and

“reducing valve” means a device which automatically reduces the pressure of the gas passing through it, and includes regulator devices.

#### Textual Amendments

**F625** Words in [Sch. 5 para. 1](#) inserted (1.8.2003) by [The Road Vehicles \(Construction and Use\) \(Amendment\) \(No. 2\) Regulations 2003 \(S.I. 2003/1690\)](#), regs. 1, **5(2)**

#### Commencement Information

**I123** [Sch. 5 para. 1](#) in force at 11.8.1986, see [reg. 1](#)

### *Gas containers*

- 2.—(1) Every gas container shall—
- (a) be capable of withstanding the pressure of the gas which may be stored in the container at the highest temperature which the gas is likely to reach,
  - (b) if fitted inside the vehicle be so arranged as to prevent so far as is practicable the possibility of gas entering the engine, passenger or living compartments due to leaks or venting from the container or valves, connections and gauges immediately adjacent to it, and the space containing these components shall be so ventilated and drained as to prevent the accumulation of gas,
  - (c) be securely attached to the vehicle in such a manner as not to be liable to displacement or damage due to vibration or other cause, and
  - (d) be so placed and so insulated or shielded as not to suffer any adverse effect from the heat of the exhaust system of any engine or any other source of heat.
- (2) Every portable gas container shall be either—
- (a) hermetically sealed, or
  - (b) fitted with a valve or cock to enable the flow of gas from the container to be stopped.
- (3) Every fixed gas container shall—
- (a) be fitted with—
    - (i) at least one pressure relief valve, and
    - (ii) at least one manually operated valve which may be extended by an internal dip tube inside the gas container so as to indicate when the container has been filled to the level corresponding to the filling ratio specified in the British Standards Institution Specification for Filling Ratios and Developed Pressure for Liquefiable and Permanent Gases (as defined, respectively, in paragraphs 3.2 and 3.5 of the said Specification) published in May 1976 under the number BS 5355, and

**Status:** Point in time view as at 31/03/2009.

**Status:** This revised version has been created from an electronic version contributed by Westlaw which was originally derived from the printed publication. **Read more** (See end of Document for details)**Changes to legislation:** There are currently no known outstanding effects for the The Road Vehicles (Construction and Use) Regulations 1986. (See end of Document for details)

(b) be conspicuously and permanently marked with its design pressure.

(4) If any fixed gas container is required to be fitted in a particular attitude or location, or if any device referred to in sub-paragraph (3) above requires the container to be fitted in such a manner, then it shall be conspicuously and permanently marked to indicate that requirement.

(5) If the operation of any pressure relief valve or other device referred to in sub-paragraph (3) above may cause gas to be released from the gas container, an outlet shall be provided to lead such gas to the outside of the vehicle so as not to suffer any adverse effect from the heat of the exhaust system of any engine or any other source of heat, and that outlet from the pressure relief valve shall not be fitted with any other valve or cock.

#### Commencement Information

**I124** Sch. 5 para. 2 in force at 11.8.1986, see [reg. 1](#)

#### *Filling systems for fixed gas containers*

**3.—**(1) Every connection for filling a fixed gas container shall be on the outside of the vehicle.

(2) There shall be fitted to every fixed gas container either—

- (a) a manually operated shut-off valve and an excess flow valve, or
- (b) a manually operated shut-off valve and a single check valve, or
- (c) a double-check valve.

and all parts of these valves in contact with gas shall be made entirely of suitable metal except that they may contain non-metal washers and seals provided that such washers and seals are supported and constrained by metal components.

(3) In every case where a pipe is attached to a gas container for the purpose of filling the gas container there shall be fitted to the end of the pipe furthest from the gas container a check valve or a double-check valve.

(4) There shall be fitted over every gas filling point on a vehicle a cap which shall—

- (a) prevent any leakage of gas from the gas filling point,
- (b) be secured to the vehicle by a chain or some other suitable means,
- (c) be made of suitable material, and
- (d) be fastened to the gas filling point by either a screw thread or other suitable means.

#### Commencement Information

**I125** Sch. 5 para. 3 in force at 11.8.1986, see [reg. 1](#)

#### *Pipelines*

**4.—**(1) Every pipeline shall be fixed in such a manner and position that—

- (a) it will not be adversely affected by the heat of the exhaust system of any engine or any other source of heat,
- (b) it is protected from vibration and strain in excess of that which it can reasonably be expected to withstand, and
- (c) in the case of a high pressure pipeline it is so far as is practicable accessible for inspection.

**Status:** Point in time view as at 31/03/2009.

**Status:** This revised version has been created from an electronic version contributed by Westlaw which was originally derived from the printed publication. **Read more** (See end of Document for details)**Changes to legislation:** There are currently no known outstanding effects for the The Road Vehicles (Construction and Use) Regulations 1986. (See end of Document for details)

- (2) Save as provided in sub-paragraph (4) below, every high pressure pipeline shall be—
- (a) a rigid line of steel, copper or copper alloy of high pressure hydraulic grade, suitable for service on road vehicles and designed for a minimum service pressure rating of not less than 75 bar absolute, and
  - (b) effectively protected against, or shielded from, or treated so as to be resistant to, external corrosion throughout its length unless it is made from material which is corrosion resistant under the conditions which it is likely to encounter in service.
- (3) No unsupported length of any high pressure pipeline shall exceed 600 mm.
- <sup>F626</sup>(4) Flexible hose may be used in a high pressure pipeline either if—
- (a) (i) it is reinforced either by stainless steel wire braid or by textile braid,  
(ii) its length does not exceed 500mm, and  
(iii) save in the case of a pipeline attached to a gas container for the purpose of filling that container the flexibility which it provides is necessary for the construction or operation of the gas system of which it forms a part, or
  - (b) its length exceeds 500mm and it complies with Annex 8 of ECE Regulation 67.01 and is approved and marked in accordance with that Regulation.
- (4A) In the case of a motor vehicle which first used gas as a fuel for its propulsion on or after 1st January 2004 a flexible hose of any length used in a high pressure pipe line shall comply with the requirements of Annex 8 of ECE Regulation 67.01 shall be approved and marked in accordance with that Regulation and shall be no longer than is reasonably necessary.]
- (5) If a high pressure pipeline or part of such a pipeline is so constructed or located that it may, in the course of its normal use (excluding the supply of fuel from a gas container), contain liquid which is prevented from flowing, a relief valve shall be incorporated in that pipeline.

#### Textual Amendments

**F626** Sch. 5 para. 4(4)(4A) substituted for Sch. 5 para. 4(4) (1.8.2003) by [The Road Vehicles \(Construction and Use\) \(Amendment\) \(No. 2\) Regulations 2003 \(S.I. 2003/1690\)](#), regs. 1, **5(3)**

#### Commencement Information

**I126** Sch. 5 para. 4 in force at 11.8.1986, see [reg. 1](#)

### *Unions and joints*

- 5.—**(1) Every union and joint on a pipeline or gas container shall be so constructed and fitted that it will—
- (a) not be liable to work loose or leak when in use, and
  - (b) be readily accessible for inspection and maintenance.
- (2) Every union on a high pressure pipeline or on a gas container shall be made of suitable metal but such a union may contain non-metal washers and seals provided that such washers and seals are supported and constrained by metal components.

#### Commencement Information

**I127** Sch. 5 para. 5 in force at 11.8.1986, see [reg. 1](#)

**Status:** Point in time view as at 31/03/2009.

**Status:** This revised version has been created from an electronic version contributed by Westlaw which was originally derived from the printed publication. **Read more** (See end of Document for details)**Changes to legislation:** There are currently no known outstanding effects for the The Road Vehicles (Construction and Use) Regulations 1986. (See end of Document for details)

### *Reducing valves*

6. Every reducing valve shall be made of suitable materials and be so fitted as to be readily accessible for inspection and maintenance.

#### **Commencement Information**

**I128** Sch. 5 para. 6 in force at 11.8.1986, see **reg. 1**

### *Pressure relief valves*

7.—(1) Every pressure relief valve which is fitted to any part of a gas system (including a gas container) shall—

- (a) be made entirely of suitable metal and so constructed and fitted as to ensure that the cooling effect of the gas during discharge shall not prevent its effective operation,
- (b) be capable, under the most extreme temperatures likely to be met (including exposure to fire), of a discharge rate which prevents the pressure of the contents of the gas system from exceeding its design pressure,
- (c) have a maximum discharge pressure not greater than the design pressure of the gas container,
- (d) be so designed and constructed as to prevent unauthorised interference with the relief pressure setting during service, and
- (e) have outlets which are—
  - (i) so sited that so far as is reasonably practicable in the event of an accident the valve and its outlets are protected from damage and the free discharge from such outlets is not impaired, and
  - (ii) so designed and constructed as to prevent the collection of moisture and other foreign matter which could adversely affect their performance.

(2) The pressure at which a pressure relief valve is designed to start lifting shall be clearly and permanently marked on every such valve.

(3) Every pressure relief valve which is fitted to a gas container shall communicate with the vapour space in the gas container and not with any liquefied gas.

#### **Commencement Information**

**I129** Sch. 5 para. 7 in force at 11.8.1986, see **reg. 1**

### *Valves and cocks*

8.—(1) A valve or cock shall be fitted to every supply pipeline as near as practicable to every fixed gas container and such valve or cock shall by manual operation enable the supply of gas from the gas container to the gas system to be stopped, and save as provided in sub-paragraph (2) below, shall—

- (a) if fitted on the outside of the vehicle, be readily visible and accessible from the outside of the vehicle, or
- (b) if fitted inside the vehicle be readily accessible for operation and be so arranged as to prevent so far as is practicable the possibility of gas entering the engine, passenger or

living compartments due to leaks, and the space containing the valve or cock shall be so ventilated and drained as to prevent the accumulation of gas in that space.

[<sup>F627</sup>(2) Where a fixed gas container supplies no gas system other than a gas propulsion system—

- (a) an electrically operated valve may be fitted in place of the valve or cock referred to in sub-paragraph (1) above; and
- (b) either—
  - (i) it shall be fitted as near as practicable to the gas container; or
  - (ii) if fitted in addition to the valve or cock referred to in sub-paragraph (1) above it shall either be incorporated into that valve or cock or be fitted immediately downstream from it; and
- (c) it shall if fitted inside the vehicle be so arranged as to prevent as far as is practicable the possibility of gas entering the engine, passenger or living compartments due to leaks, and the space containing the valve shall be so ventilated and drained as to prevent the accumulation of gas in that space.]

(3) A notice clearly indicating the position, purpose and method of operating every valve or cock referred to in sub-paragraphs (1) and (2) above shall be fixed—

- (a) in all cases, in a conspicuous position on the outside of the vehicle, and
- (b) in every case where the valve or cock is located inside the vehicle in a conspicuous position adjacent to the gas container.

(4) In the case of a high pressure pipeline for the conveyance of gas from the gas container an excess flow valve shall be fitted as near as practicable to the gas container and such valve shall operate in the event of a fracture of the pipeline or other similar failure.

(5) All parts of every valve or cock referred to in this paragraph which are in contact with gas shall be made of suitable metal, save that they may contain non-metal washers and seals provided that such washers and seals are supported and constrained by metal components.

**Textual Amendments**

**F627** Sch. 5 para. 8(2) substituted (1.8.2003) by [The Road Vehicles \(Construction and Use\) \(Amendment\) \(No. 2\) Regulations 2003 \(S.I. 2003/1690\)](#), regs. 1, **5(4)**

**Commencement Information**

**I130** Sch. 5 para. 8 in force at 11.8.1986, see [reg. 1](#)

*Gauges*

**9.** Every gauge connected to a gas container or to a pipeline shall be so constructed as to be unlikely to deteriorate under the action of the gas used or to be used and shall be so constructed and fitted that—

- (a) no gas can escape into any part of the vehicle as a result of any failure of the gauge, and
- (b) in the event of any failure of the gauge the supply of gas to the gauge can be readily stopped.

Provided that the requirement specified in sub-paragraph (b) above shall not apply in respect of a gauge fitted as an integral part of a gas container.

**Status:** Point in time view as at 31/03/2009.

**Status:** This revised version has been created from an electronic version contributed by Westlaw which was originally derived from the printed publication. **Read more** (See end of Document for details)**Changes to legislation:** There are currently no known outstanding effects for the The Road Vehicles (Construction and Use) Regulations 1986. (See end of Document for details)

**Commencement Information**

**I131** Sch. 5 para. 9 in force at 11.8.1986, see **reg. 1**

*Propulsion systems*

- 10.**—(1) Every gas propulsion system shall be so designed and constructed that—
- (a) the supply of gas to the engine is automatically stopped by the operation of a valve when the engine is not running at all or is not running on the supply of gas, and
  - (b) where a reducing valve is relied on to comply with sub-paragraph (a) above, the supply of gas to the engine is automatically stopped by the operation of an additional valve when the engine is switched off.
- (2) Where the engine of a vehicle is constructed or adapted to run on one or more fuels as alternatives to gas, the safety and efficiency of the engine and any fuel system shall not be impaired by the presence of any other fuel system.

**Commencement Information**

**I132** Sch. 5 para. 10 in force at 11.8.1986, see **reg. 1**

*Special requirements for buses*

- 11.** In the case of a bus there shall be fitted as near as practicable to the gas container a valve which shall stop the flow of gas into the gas supply pipeline in the event of—
- (a) the angle of tilt of the vehicle exceeding that referred to in regulation 6 of the Public Service Vehicles (Conditions of Fitness, Equipment, Use and Certification) Regulations 1981(14), and
  - (b) the deceleration of the vehicle exceeding 5g.

**Commencement Information**

**I133** Sch. 5 para. 11 in force at 11.8.1986, see **reg. 1**

*Gas-fired appliances*

- 12.** Every part of a gas-fired appliance shall be—
- (a) so designed and constructed that leakage of gas is unlikely to occur, and
  - (b) constructed of materials which are compatible both with each other and with the gas used.

**Commencement Information**

**I134** Sch. 5 para. 12 in force at 11.8.1986, see **reg. 1**

- 13.** Every gas-fired appliance shall be—

(14) To which there are no relevant amending instruments.

**Status:** Point in time view as at 31/03/2009.

**Status:** This revised version has been created from an electronic version contributed by Westlaw which was originally derived from the printed publication. **Read more** (See end of Document for details)**Changes to legislation:** There are currently no known outstanding effects for the The Road Vehicles (Construction and Use) Regulations 1986. (See end of Document for details)

- (a) so located as to be easily inspected and maintained,
- (b) so located and either insulated or shielded that its use shall not cause or be likely to cause danger due to the presence of any flammable material,
- (c) so constructed and located as not to impose undue stress on any pipe or fitting, and
- (d) so fastened or located as not to work loose or move in relation to the vehicle.

**Commencement Information**

**I135** Sch. 5 para. 13 in force at 11.8.1986, see [reg. 1](#)

**14.** With the exception of catalytic heating appliances, every appliance of the kind described in regulation 96(3)(b) or (c) which is fitted to a motor vehicle shall be fitted with a flue which shall be—

- (a) connected to an outlet which is on the outside of the vehicle,
- (b) constructed and located so as to prevent any expelled matter from entering the vehicle, and
- (c) located so that it will not cause any adverse effect to, or suffer any adverse effect from, the exhaust outlet of any engine or any other source of heat.

**Commencement Information**

**I136** Sch. 5 para. 14 in force at 11.8.1986, see [reg. 1](#)

*General requirements*

**15.** Every part of a gas propulsion system or a gas-fired appliance system, excluding the appliance itself, shall be—

- (a) so far as is practicable so located or protected as not to be exposed to accidental damage,
- (b) soundly and properly constructed of materials which are compatible with one another and with the gas used or to be used and which are capable of withstanding the loads and stresses likely to be met in operation, and
- (c) so designed and constructed that leakage of gas is unlikely to occur.

**Commencement Information**

**I137** Sch. 5 para. 15 in force at 11.8.1986, see [reg. 1](#)

SCHEDULE 6

(see regulation 41)

CONSTRUCTION OF MINIBUSES

The requirements referred to in regulation 41 are as follows—

**Exhaust pipes**

**1.** The outlet of every exhaust pipe fitted to a minibus shall be either at the rear or on the off side of the vehicle.

**Status:** Point in time view as at 31/03/2009.

**Status:** This revised version has been created from an electronic version contributed by Westlaw which was originally derived from the printed publication. **Read more** (See end of Document for details)**Changes to legislation:** There are currently no known outstanding effects for the The Road Vehicles (Construction and Use) Regulations 1986. (See end of Document for details)

#### Commencement Information

**I138** Sch. 6 para. 1 in force at 11.8.1986, see [reg. 1](#)

#### Doors—number and position

- 2.—(1) Every minibus shall be fitted with at least—
- (a) one service door on the near side of the vehicle; and
  - (b) one emergency door either at the rear or on the off side of the vehicle so, however, that any emergency door fitted on the off side of the vehicle shall be in addition to the driver's door and there shall be no requirement for an emergency door on a minibus if it has a service door at the rear in addition to the service door on the near side.
- (2) No minibus shall be fitted with any door on its off side other than a driver's door and an emergency door.

#### Commencement Information

**I139** Sch. 6 para. 2 in force at 11.8.1986, see [reg. 1](#)

#### Emergency Doors

3. Every emergency door fitted to a minibus, whether or not required pursuant to these Regulations, shall—
- (a) be clearly marked, in letters not less than 25 mm high, on both the inside and the outside, “EMERGENCY DOOR” or “FOR EMERGENCY USE ONLY”, and the means of its operation shall be clearly indicated on or near the door;
  - (b) if hinged, open outwards;
  - (c) be capable of being operated manually; and
  - (d) when fully opened, give an aperture in the body of the vehicle not less than 1210 mm high nor less than 530 mm wide.

#### Commencement Information

**I140** Sch. 6 para. 3 in force at 11.8.1986, see [reg. 1](#)

#### Power-operated doors

- 4.—(1) Every power-operated door fitted to a minibus shall—
- (a) incorporate transparent panels so as to enable a person immediately inside the door to see any person immediately outside the door;
  - (b) be capable of being operated by a mechanism controlled by the driver of the vehicle when in the driving seat;
  - (c) be capable, in the event of an emergency or a failure of the supply of power for the operation of the door, of being opened from both inside and outside the vehicle by controls which—
    - (i) over-ride all other controls,



**Status:** Point in time view as at 31/03/2009.

**Status:** This revised version has been created from an electronic version contributed by Westlaw which was originally derived from the printed publication. **Read more** (See end of Document for details)**Changes to legislation:** There are currently no known outstanding effects for the The Road Vehicles (Construction and Use) Regulations 1986. (See end of Document for details)

- (ii) are placed on, or adjacent to, the door, and
- (iii) are accompanied by markings which clearly indicate their position and method of operation and state that they may not be used by passengers except in an emergency;
- (d) have a soft edge so that a trapped finger is unlikely to be injured; and
- (e) be controlled by a mechanism by virtue of which if the door, when closing, meets a resistance exceeding 150 Newtons, either
  - the door will cease to close and begin to open, or
  - the closing force will cease and the door will become capable of being opened manually.

(2) No minibus shall be equipped with a system for the storage or transmission of energy in respect of the opening or closing of any door which, either in normal operation or if the system fails, is capable of adversely affecting the operation of the vehicle's braking system.

#### Commencement Information

**I141** Sch. 6 para. 4 in force at 11.8.1986, see [reg. 1](#)

### Locks, handles and hinges of doors

5. No minibus shall be fitted with—
- (a) a door which can be locked from the outside unless, when so locked, it is capable of being opened from inside the vehicle when stationary;
  - (b) a handle or other device for opening any door, other than the driver's door, from inside the vehicle unless the handle or other device is designed so as to prevent, so far as is reasonably practicable, the accidental opening of the door, and is fitted with a guard or transparent cover or so designed that it must be raised to open the door;
  - (c) a door which is not capable of being opened, when not locked, from inside and outside the vehicle by a single movement of the handle or other device for opening the door;
  - (d) a door in respect of which there is not a device capable of holding the door closed so as to prevent any passenger falling through the doorway;
  - (e) a side door which opens outwards and is hinged at the edge nearest the rear of the vehicle except in the case of a door having more than one rigid panel;
  - (f) a door, other than a power-operated door, in respect of which there is not either—
    - (i) a slam lock of the two-stage type; or
    - (ii) a device by means of which the driver, when occupying the driver's seat, is informed if the door is not securely closed, such device being operated by movement of the handle or other device for opening the door or, in the case of a handle or other device with a spring-return mechanism, by movement of the door as well as of the handle or other device.

Provided that the provisions of sub-paragraphs (a), (c), (d) and (f) of this paragraph shall not apply in respect of a near side rear door forming part of a pair of doors fitted at the rear of a vehicle if that door is capable of being held securely closed by the other door of that pair.

#### Commencement Information

**I142** Sch. 6 para. 5 in force at 11.8.1986, see [reg. 1](#)

**Status:** Point in time view as at 31/03/2009.

**Status:** This revised version has been created from an electronic version contributed by Westlaw which was originally derived from the printed publication. **Read more** (See end of Document for details)**Changes to legislation:** There are currently no known outstanding effects for the The Road Vehicles (Construction and Use) Regulations 1986. (See end of Document for details)

## View of doors

6.—(1) Save as provided in sub-paragraph (2), every minibus shall be fitted with mirrors or other means so that the driver, when occupying the driver's seat, can see clearly the area immediately inside and outside every service door of the vehicle.

(2) The provisions of sub-paragraph (1) shall be deemed to be satisfied in respect of a rear service door if a person 1.3 metres tall standing 1 metre behind the vehicle is visible to the driver when occupying the driver's seat.

### Commencement Information

**I143** Sch. 6 para. 6 in force at 11.8.1986, see [reg. 1](#)

## Access to doors

7.—(1) Save as provided in sub-paragraph (2), there shall be unobstructed access from every passenger seat in a minibus to at least two doors one of which must be on the nearside of the vehicle and one of which must be either at the rear or on the offside of the vehicle.

(2) Access to one only of the doors referred to in sub-paragraph (1) may be obstructed by either or both of—

- (a) a seat which when tilted or folded does not obstruct access to that door; and
- (b) a lifting platform or ramp which—
  - (i) does not obstruct the handle or other device on the inside for opening the door with which the platform or ramp is associated, and
  - (ii) when the door is open, can be pushed or pulled out of the way from the inside so as to leave the doorway clear for use in an emergency.

### Commencement Information

**I144** Sch. 6 para. 7 in force at 11.8.1986, see [reg. 1](#)

## Grab handles and hand rails

8. Every minibus shall be fitted as respects every side service door with a grab handle or a hand rail to assist passengers to get on or off the vehicle.

### Commencement Information

**I145** Sch. 6 para. 8 in force at 11.8.1986, see [reg. 1](#)

## Seats

9.—(1) No seat shall be fitted to any door of a minibus.

(2) Every seat and every wheelchair anchorage fitted to a minibus shall be fixed to the vehicle.

(3) No seat, other than a wheelchair, fitted to a minibus shall be less than 400 mm wide, and in ascertaining the width of a seat no account shall be taken of any arm-rests, whether or not they are folded back or otherwise put out of use.

**Status:** Point in time view as at 31/03/2009.

**Status:** This revised version has been created from an electronic version contributed by Westlaw which was originally derived from the printed publication. **Read more** (See end of Document for details)**Changes to legislation:** There are currently no known outstanding effects for the The Road Vehicles (Construction and Use) Regulations 1986. (See end of Document for details)

(4) No minibus shall be fitted with an anchorage for a wheelchair in such a manner that a wheelchair secured to the anchorage would face either side of the vehicle.

(5) No minibus shall be fitted with a seat—

- (a) facing either side of the vehicle and immediately forward of a rear door unless the seat is fitted with an arm-rest or similar device to guard against a passenger on that seat falling through the doorway; or
- (b) so placed that a passenger on it would, without protection, be liable to be thrown through any doorway which is provided with a power-operated door or down any steps, unless the vehicle is fitted with a screen or guard which affords adequate protection against that occurrence.

**Commencement Information**

**I146** Sch. 6 para. 9 in force at 11.8.1986, see [reg. 1](#)

**Electrical equipment and wiring**

**10.**—(1) Save as provided in sub-paragraph (2) no minibus shall be fitted with any—

- (a) electrical circuit which is liable to carry a current exceeding that for which it was designed;
- (b) cable for the conduct of electricity unless it is suitably insulated and protected from damage;
- (c) electrical circuit, other than a charging circuit, which includes any equipment other than—
  - (i) a starter motor,
  - (ii) a glow plug,
  - (iii) an ignition circuit, and
  - (iv) a device to stop the vehicle's engine,unless it includes a fuse or circuit breaker so, however, that one fuse or circuit breaker may serve more than one circuit; or
- (d) electrical circuit with a voltage exceeding 100 volts unless there is connected in each pole of the main supply of electricity which is not connected to earth a manually-operated switch which is—
  - (i) capable of disconnecting the circuit, or, if there is more than one, every circuit, from the main supply,
  - (ii) not capable of disconnecting any circuit supplying any lamp with which the vehicle is required to be fitted, and
  - (iii) located inside the vehicle in a position readily accessible to the driver.

(2) The provisions of sub-paragraph (1) do not apply in respect of a high tension ignition circuit or a circuit within a unit of equipment.

**Commencement Information**

**I147** Sch. 6 para. 10 in force at 11.8.1986, see [reg. 1](#)

**Status:** Point in time view as at 31/03/2009.

**Status:** This revised version has been created from an electronic version contributed by Westlaw which was originally derived from the printed publication. **Read more** (See end of Document for details)**Changes to legislation:** There are currently no known outstanding effects for the The Road Vehicles (Construction and Use) Regulations 1986. (See end of Document for details)

## Fuel tanks

11. No minibus shall be fitted with a fuel tank or any apparatus for the supply of fuel which is in the compartments or other spaces provided for the accommodation of the driver or passengers.

### Commencement Information

I148 Sch. 6 para. 11 in force at 11.8.1986, see [reg. 1](#)

## Lighting of steps

12. Every minibus shall be provided with lamps to illuminate every step at a passenger exit or in a gangway.

### Commencement Information

I149 Sch. 6 para. 12 in force at 11.8.1986, see [reg. 1](#)

## General construction and maintenance

13. Every minibus, including all bodywork and fittings, shall be soundly and properly constructed of suitable materials and maintained in good and serviceable condition, and shall be of such design as to be capable of withstanding the loads and stresses likely to be met in the normal operation of the vehicle.

### Commencement Information

I150 Sch. 6 para. 13 in force at 11.8.1986, see [reg. 1](#)

## Definitions

14. In this Schedule—

“driver's door” means a door fitted to a minibus for use by the driver;

“emergency door” means a door fitted to a minibus for use by passengers in an emergency ; and

“service door” means a door fitted to a minibus for use by passengers in normal circumstances .

### Commencement Information

I151 Sch. 6 para. 14 in force at 11.8.1986, see [reg. 1](#)

## SCHEDULE 7

FIRE EXTINGUISHING APPARATUS AND FIRST AID EQUIPMENT FOR MINIBUSES  
(see regulation 42)

## [<sup>F628</sup>PART I

### FIRE EXTINGUISHING APPARATUS

#### Textual Amendments

**F628** Sch. 7 Pt. 1 substituted (11.1.1990) by [The Road Vehicles \(Construction and Use\) \(Amendment\) \(No. 4\) Regulations 1989 \(S.I. 1989/2360\)](#), regs. 1, 5

A fire extinguisher which complies in all respects with the specification for portable fire extinguishers issued by the British Standards Institution numbered BS 5423: 1977 or BS 5423: 1980 or BS 5423:1987 and which\_

- (a) has a minimum test fire rating of 8A or 21B, and
  - (b) contains water or foam or contains, and is marked to indicate that it contains, halon 1211 or halon 1301.]
- (see regulation 43)

## PART II

### FIRST AID EQUIPMENT

#### Commencement Information

**I152** Sch. 7 Pt. II in force at 11.8.1986, see [reg. 1](#)

- (i) Ten antiseptic wipes, foil packed;
- (ii) One conforming disposable bandage (not less than 7.5 cm wide);
- (iii) Two triangular bandages;
- (iv) One packet of 24 assorted adhesive dressings;
- (v) Three large sterile unmedicated ambulance dressings (not less than 15.0 cm × 20.0 cm);
- (vi) Two sterile eye pads, with attachments;
- (vii) Twelve assorted safety pins; and
- (viii) One pair of rustless blunt-ended scissors.

## [<sup>F629</sup>SCHEDULE 7XA

Regulations 55A(1) and 61(11)

### END OF SERIES EXEMPTIONS

#### Textual Amendments

**F629** Sch. 7XA inserted (1.10.1996) by [The Road Vehicles \(Construction and Use\) \(Amendment\) \(No. 5\) Regulations 1996 \(S.I. 1996/2329\)](#), regs. 1, 11, [Sch.](#)

**Status:** Point in time view as at 31/03/2009.

**Status:** This revised version has been created from an electronic version contributed by Westlaw which was originally derived from the printed publication. **Read more** (See end of Document for details)**Changes to legislation:** There are currently no known outstanding effects for the The Road Vehicles (Construction and Use) Regulations 1986. (See end of Document for details)

## PART I

### MODIFICATION OF [F<sup>630</sup>REGULATIONS 55A, 61 AND 61A] IN RELATION TO END OF SERIES VEHICLES

#### Textual Amendments

**F630** Words in Sch. 7XA Pt 1 heading substituted (1.1.2001) by [The Road Vehicles \(Construction and Use\) \(Amendment\) \(No. 3\) Regulations 2000](#) (S.I. 2000/3197), regs. 1, **8(2)**

#### Modification of [F<sup>631</sup>regulations 55A, 61 and 61A]

- 1.—(1) An item numbered 2 or higher in the Table in regulation 55A shall not apply to—
- (a) a type approval end of series vehicle;
  - (b) a non-type approval end of series vehicle; or
  - (c) a late entry into service vehicle,

if it is first used before the first anniversary of the date specified in column 3 of the item.

(2) An item numbered 8, 9 or 11 in Table II of regulation 61 shall not apply to a type approval end of series vehicle if it is first used before the first anniversary of the date specified in column 3 of the item.

(3) An item numbered 9 or 11 in Table II of regulation 61 shall not apply to a non-type approval end of series vehicle if it is first used before the first anniversary of the date specified in column 3 of the item.

- (4) An item numbered 10 or higher (other than 11) in Table II of regulation 61 shall not apply to—
- (a) a type approval end of series vehicle;
  - (b) a non-type approval end of series vehicle; or
  - (c) a late entry into service vehicle,

if it is first used before the first anniversary of the date specified in column 3 of the item.

[F<sup>632</sup>(4A) No provision of any Community Directive specified in an item numbered 1 or 2 in the Table in regulation 61A shall be deemed to be a design, construction or equipment requirement applying to, or to impose limit values in relation to, a vehicle by virtue of paragraphs (2) and (3) of regulation 61A, if the vehicle is—

- (a) a type approval end of series vehicle,
- (b) a non-type-approval end of series vehicle, or
- (c) a late entry into service vehicle,

in relation to such a provision, and the vehicle is first used before the first anniversary of the date as is specified (as defined in regulation 61A) by the relevant Community Directive in item 1 or 2 in the Table in regulation 61A.]

(5) Parts II, III and IV of this Schedule shall have effect for the purpose of interpreting the expressions “type approval end of series vehicle”, “non-type approval end of series vehicle” and “late entry into service vehicle” respectively for the purposes of this paragraph.

### Textual Amendments

- F631** Words in Sch. 7XA para. 1 heading substituted (1.1.2001) by The Road Vehicles (Construction and Use) (Amendment) (No. 3) Regulations 2000 (S.I. 2000/3197), regs. 1, **8(2)**
- F632** Sch. 7XA para. 1(4A) substituted (20.10.2006) by The Road Vehicles (Construction and Use) and Motor Vehicles (Type Approval for Goods Vehicles) (Great Britain) (Amendment) Regulations 2006 (S.I. 2006/2565), regs. 1(2), **6(2)**

## PART II

### MEANING OF “TYPE APPROVAL END OF SERIES VEHICLE” IN PART I

#### Meaning of “type approval end of series vehicle” for the purposes of paragraph 1

2.—(1) For the purposes of paragraph 1, a vehicle is a type approval end of series vehicle, in relation to item 8, 9 or 11 in Table II in regulation 61, if it meets the requirements of sub-paragraph (3) in relation to the item.

(2) For the purposes of paragraph 1 [<sup>F633</sup>, and subject to regulation 3 of the Motor Vehicles (Type Approval for Goods Vehicles) (Great Britain) (Amendment) Regulations 2007], a vehicle is a type approval end of series vehicle, in relation to an item numbered 2 or higher in the Table in regulation 55A or an item numbered 10 or higher (other than item 11) in Table II in regulation 61 [<sup>F634</sup> or any provision of any Community Directive specified in item 1 or 2 in the Table in regulation 61A] if—

- (a) by virtue of [<sup>F635</sup> either item 2J of Schedule 1 or] Schedule 1C to the Type Approval for Goods Vehicles Regulations, <sup>F636</sup> ...
- (b) by virtue of Schedule 1C to the Type Approval (Great Britain) Regulations, [<sup>F637</sup> or
- (c) by virtue of regulations 12 and 13 of, and Schedule 2 to, the EC Whole Vehicle Type Approval Regulations,]

( [<sup>F638</sup> which] [<sup>F639</sup>, other than item 2J of Schedule 1,] in certain circumstances defer the date on which certain requirements relating to exhaust emissions, noise and silencers cease to apply) the type approval requirements that applied to the vehicle on the date specified in column 3 of the item [<sup>F640</sup> or, in relation to any provision of any Community Directive specified in item 1 or 2 in the Table in regulation 61A, on the date as is specified (as defined in regulation 61A) by the relevant Community Directive] are the same as the type approval requirements that applied to the vehicle immediately before the date so specified in that column of that item [<sup>F641</sup> or in relation to any provision of any Community Directive specified in item 1 or 2 in the Table in regulation 61A, the date as is specified by the relevant Community Directive].

[<sup>F642</sup>(2A) For the purposes of paragraph 1, a vehicle is a type-approval end of series vehicle in relation to an item in the Table in regulation 55A, or in Table II in regulation 61, or any provision in any Community Directive specified in item 1 or 2 in the Table in regulation 61A, if it has been exempted from that item or provision under—

- (a) the laws of a relevant State (as defined by paragraph 5(1)(c)) other than the United Kingdom, or
  - (b) the laws applicable in Northern Ireland,
- pursuant to Article 8(2)(b) of the Framework Directive.]

**Status:** Point in time view as at 31/03/2009.

**Status:** This revised version has been created from an electronic version contributed by Westlaw which was originally derived from the printed publication. **Read more** (See end of Document for details)**Changes to legislation:** There are currently no known outstanding effects for the The Road Vehicles (Construction and Use) Regulations 1986. (See end of Document for details)

- (3) A vehicle meets the requirements of this sub-paragraph, in relation to the item, if—
- (a) it was manufactured during the relevant period;
  - (b) one of the following conditions is satisfied—
    - (i) a certificate of conformity was issued in respect of the vehicle before the date specified in column 3 of the item by virtue of a TAC issued before the date specified in column 4 of the Table in paragraph 6 in relation to the item, or
    - (ii) a sub-MAC was issued in respect of the vehicle before the date specified in column 3 of the item by virtue of a MAC issued before the date specified in column 4 of that Table;
  - (c) it was in the territory of a relevant state at some time before the date specified in column 3 of the item; and
  - (d) the number of relevant vehicles which were—
    - (i) manufactured before that vehicle was manufactured, and
    - (ii) still in existence on the date specified in column 3 of that item, was less than the specified number of 50 (whichever is the greater).
- (4) For the purposes of sub-paragraph (3)—
- (a) “MAC” means a Minister’s approval certificate issued under section 58(1) of the Road Traffic Act 1988;
  - (b) “sub-MAC” means a Minister’s approval certificate issued under section 58(4) of the Road Traffic Act 1988; and
  - (c) “TAC” means a type approval certificate.

#### Textual Amendments

- F633** Words in Sch. 7XA para. 2(2) inserted (14.3.2007) by [The Motor Vehicles \(Type Approval for Goods Vehicles\) \(Great Britain\) \(Amendment\) Regulations 2007 \(S.I. 2007/361\)](#), regs. 1(2), **3(2)**
- F634** Words in Sch. 7XA para. 2(2) substituted (20.10.2006) by [The Road Vehicles \(Construction and Use\) and Motor Vehicles \(Type Approval for Goods Vehicles\) \(Great Britain\) \(Amendment\) Regulations 2006 \(S.I. 2006/2565\)](#), regs. 1(2), **6(3)(a)**
- F635** Words in Sch. 7XA para. 2(2)(a) inserted (1.10.2007) by [The Road Vehicles \(Construction and Use\) \(Amendment\) \(No.2\) Regulations 2007 \(S.I. 2007/2544\)](#), regs. 1, **2(a)**
- F636** Word in Sch. 7XA para. 2(2) omitted (20.10.2006) by virtue of [The Road Vehicles \(Construction and Use\) and Motor Vehicles \(Type Approval for Goods Vehicles\) \(Great Britain\) \(Amendment\) Regulations 2006 \(S.I. 2006/2565\)](#), regs. 1(2), **6(3)(d)**
- F637** Sch. 7XA para. 2(2)(c) and word inserted (20.10.2006) by [The Road Vehicles \(Construction and Use\) and Motor Vehicles \(Type Approval for Goods Vehicles\) \(Great Britain\) \(Amendment\) Regulations 2006 \(S.I. 2006/2565\)](#), regs. 1(2), **6(3)(e)**
- F638** Word in Sch. 7XA para. 2(2) substituted (20.10.2006) by [The Road Vehicles \(Construction and Use\) and Motor Vehicles \(Type Approval for Goods Vehicles\) \(Great Britain\) \(Amendment\) Regulations 2006 \(S.I. 2006/2565\)](#), regs. 1(2), **6(3)(f)**
- F639** Words in Sch. 7XA para. 2(2)(a) inserted (1.10.2007) by [The Road Vehicles \(Construction and Use\) \(Amendment\) \(No.2\) Regulations 2007 \(S.I. 2007/2544\)](#), regs. 1, **2(b)**
- F640** Words in Sch. 7XA para. 2(2) substituted (20.10.2006) by [The Road Vehicles \(Construction and Use\) and Motor Vehicles \(Type Approval for Goods Vehicles\) \(Great Britain\) \(Amendment\) Regulations 2006 \(S.I. 2006/2565\)](#), regs. 1(2), **6(3)(b)**
- F641** Words in Sch. 7XA para. 2(2) substituted (20.10.2006) by [The Road Vehicles \(Construction and Use\) and Motor Vehicles \(Type Approval for Goods Vehicles\) \(Great Britain\) \(Amendment\) Regulations 2006 \(S.I. 2006/2565\)](#), regs. 1(2), **6(3)(c)**



**Status:** This revised version has been created from an electronic version contributed by Westlaw which was originally derived from the printed publication. **Read more** (See end of Document for details)**Changes to legislation:** There are currently no known outstanding effects for the The Road Vehicles (Construction and Use) Regulations 1986. (See end of Document for details)

**F642** Sch. 7XA para. 2(2A) inserted (20.10.2006) by [The Road Vehicles \(Construction and Use\) and Motor Vehicles \(Type Approval for Goods Vehicles\) \(Great Britain\) \(Amendment\) Regulations 2006 \(S.I. 2006/2565\)](#), regs. 1(2), **6(4)**

**Modifications etc. (not altering text)**

**C5** Sch. 7XA para. 2(2) modified (14.3.2007) by [The Motor Vehicles \(Type Approval for Goods Vehicles\) \(Great Britain\) \(Amendment\) Regulations 2007 \(S.I. 2007/361\)](#), regs. 1(2), **3**

**Meaning of “relevant vehicle” for the purposes of this Part**

**3.—(1)** For the purposes of paragraph 2(3)(d), in relation to a particular vehicle to which Type Approval for Goods Vehicles Regulations apply (in this paragraph referred to as “the vehicle in question”) and a particular item, a “relevant vehicle” is a vehicle (other than the vehicle in question) which—

- (a) is a vehicle to which those Regulations apply;
- (b) meets the requirements specified in paragraphs (a) to (c) of paragraph 2(3);
- (c) was manufactured by the manufacturer of the vehicle in question; and
- (d) had not been registered under the Vehicles (Excise) Act 1971 or the Vehicle Excise and Registration Act 1994 before the date specified in column 3 of the item.

(2) For the purposes of paragraph 2(3)(d) in relation to a particular vehicle to which the Type Approval (Great Britain) Regulations apply (in this paragraph referred to as “the vehicle in question”) and a particular item, a “relevant vehicle” is a vehicle (other than the vehicle in question) which—

- (a) is a vehicle to which those Regulations apply;
- (b) meets the requirements specified in paragraphs (a) to (c) of paragraph 2(3);
- (c) was manufactured by the manufacturer of the vehicle in question; and
- (d) had not been registered under the Vehicle Excise and Registration Act 1994 before the date specified in column 3 of the item.

**Meaning of “specified number” for the purposes of this Part**

**4.—(1)** For the purposes of paragraph 2(3)(d), in relation to a particular vehicle to which the Type Approval (Great Britain) Regulations apply (in this paragraph referred to as “the vehicle in question”) and a particular item, “the specified number” is 10% of the total number of vehicles to which those Regulations apply that were both—

- (a) manufactured by the manufacturer of the vehicle in question; and
- (b) registered under the Vehicles Excise Act 1971 or the Vehicle Excise and Registration Act 1994 during the one year period ending immediately before the date specified in column 3 of the item.

(2) For the purposes of paragraph 2(3)(d), in relation to a particular vehicle to which the Type Approval for Goods Vehicles Regulations apply (in this paragraph referred to as “the vehicle in question”) and a particular item, “the specified number” is 10% of the total number of vehicles to which those Regulations apply that were both—

- (a) manufactured by the manufacturer of the vehicle in question, and
- (b) registered under the Vehicles Excise Act 1971 or the Vehicle Excise and Registration Act 1994 during the one year period ending immediately before the date specified in column 3 of the item.

**Status:** Point in time view as at 31/03/2009.

**Status:** This revised version has been created from an electronic version contributed by Westlaw which was originally derived from the printed publication. **Read more** (See end of Document for details)**Changes to legislation:** There are currently no known outstanding effects for the The Road Vehicles (Construction and Use) Regulations 1986. (See end of Document for details)

### **Circumstances in which a vehicle is to be regarded as having been in the territory of a relevant state for the purposes of this Part**

- 5.—(1) For the purposes of paragraph 2(3)(c)—
- (a) at any material time before the 5th November 1993, “relevant state” means a member State;
  - (b) in relation to any time on or after 5th November 1993 but before 1st May 1995, “relevant state” means an EEA State other than Liechtenstein; and
  - (c) in relation to any time on or after 1st May 1995, “relevant state” means any EEA State.
- (2) For the purposes of this paragraph—
- “EEA agreement” means the Agreement on the European Economic Area signed at Oporto on the 2nd May 1992 as adjusted by the protocol signed at Brussels on the 17th March 1993; and
- “EEA State” means a State which is a contracting party to the EEA agreement.

### **Meaning of “relevant period” for the purposes of this Part**

6. For the purposes of this Part, “the relevant period” in relation to an item numbered 8, 9 or 11 in Table II in regulation 61 is the period—
- (a) beginning on the date specified in column 2 of the Table below against that item; and
  - (b) ending immediately before the date specified in column 3 of the Table below against that item.

**THE TABLE**

1	2	3	4	5
Item in Table II in regulation 61	Date on which the relevant period begins:	Date immediately before which the relevant period ends.	Date before which type approval etc. needs to be granted	Date in column 3 of Table II in regulation 61
8	1st August 1990	1st September 1992	1st July 1992	31st December 1992
9	1st April 1991	1st October 1993	1st October 1993	1st October 1993
11	1st August 1992	1st August 1994	1st October 1993	1st October 1994

## **PART III**

### **MEANING OF “NON-TYPE APPROVAL END OF SERIES VEHICLE” IN PART I**

#### **Meaning of “non-type approval end of series vehicle” in paragraph 1**

7.—<sup>[F643]</sup>(1) For the purposes of paragraph 1, a vehicle is a non-type approval end of series vehicle in relation to an item or provision if it meets the requirements of sub-paragraph (2) in relation to the item or provision.]

<sup>[F644]</sup>(2) A vehicle meets the requirements of this sub-paragraph in relation to an item or provision if—]

**Status:** Point in time view as at 31/03/2009.

**Status:** This revised version has been created from an electronic version contributed by Westlaw which was originally derived from the printed publication. **Read more** (See end of Document for details)**Changes to legislation:** There are currently no known outstanding effects for the The Road Vehicles (Construction and Use) Regulations 1986. (See end of Document for details)

- (a) it is a vehicle to which neither the Type Approval (Great Britain) Regulations nor the Type Approval for Goods Vehicles Regulations [<sup>F645</sup>nor the EC Whole Vehicle Type Approval Regulations] apply;
- (b) it was manufactured during the relevant period;
- (c) no EC certificate of conformity has been issued in respect of the vehicle;
- (d) it was in the territory of a relevant state at some time before the end of the relevant period; and
- (e) the number of relevant vehicles which were both—
  - (i) manufactured before that vehicle was manufactured, and
  - (ii) still in existence on the date specified in column 3 in the item [<sup>F646</sup>or in relation to any provision of any Community Directive specified in item 1 or 2 in the Table in regulation 61A, on the date as is specified (as defined in regulation 61A) by the relevant Community Directive, is less than the specified number, or 100, whichever is the greater.]

#### Textual Amendments

**F643** Sch. 7XA para. 7(1) substituted (20.10.2006) by The Road Vehicles (Construction and Use) and Motor Vehicles (Type Approval for Goods Vehicles) (Great Britain) (Amendment) Regulations 2006 (S.I. 2006/2565), regs. 1(2), **6(5)**

**F644** Words in Sch. 7XA para. 7(2) substituted (20.10.2006) by The Road Vehicles (Construction and Use) and Motor Vehicles (Type Approval for Goods Vehicles) (Great Britain) (Amendment) Regulations 2006 (S.I. 2006/2565), regs. 1(2), **6(6)**

**F645** Words in Sch. 7XA para. 7(2)(a) inserted (20.10.2006) by The Road Vehicles (Construction and Use) and Motor Vehicles (Type Approval for Goods Vehicles) (Great Britain) (Amendment) Regulations 2006 (S.I. 2006/2565), regs. 1(2), **6(7)**

**F646** Words in Sch. 7XA para. 7(2)(e)(ii) replaced (20.10.2006) by The Road Vehicles (Construction and Use) and Motor Vehicles (Type Approval for Goods Vehicles) (Great Britain) (Amendment) Regulations 2006 (S.I. 2006/2565), regs. 1(2), **6(8)**

#### Meaning of “relevant vehicle” for the purposes of this Part

**8.** For the purposes of paragraph 7(2)(e), in relation to a particular vehicle (in this paragraph referred to as “the vehicle in question”) and a particular item [<sup>F647</sup>, or provision], a “relevant vehicle” is a vehicle (other than the vehicle in question) which—

- (a) meets the requirements specified in paragraphs (a) to (d) of paragraph 7(2);
- [<sup>F648</sup>(b) is a “vehicle” within the meaning of Community Directive 70/220 (as amended by Community Directive 83/351) or Community Directive 2005/55 (as amended by Community Directives 2005/78 and 2006/51);]
- (c) was manufactured by the manufacturer of the vehicle in question;
- (d) had not been registered under the Vehicles (Excise) Act 1971 or the Vehicle Excise and Registration Act 1994 during the relevant period.

#### Textual Amendments

**F647** Words in Sch. 7XA para. 8 inserted (20.10.2006) by The Road Vehicles (Construction and Use) and Motor Vehicles (Type Approval for Goods Vehicles) (Great Britain) (Amendment) Regulations 2006 (S.I. 2006/2565), regs. 1(2), **6(9)**

**Status:** Point in time view as at 31/03/2009.

**Status:** This revised version has been created from an electronic version contributed by Westlaw which was originally derived from the printed publication. **Read more** (See end of Document for details)**Changes to legislation:** There are currently no known outstanding effects for the The Road Vehicles (Construction and Use) Regulations 1986. (See end of Document for details)

**F648** Sch. 7XA para. 8(b) substituted (9.11.2006) by The Road Vehicles (Construction and Use) and Motor Vehicles (Type Approval for Goods Vehicles) (Great Britain) (Amendment) Regulations 2006 (S.I. 2006/2565), regs. 1(2), **6(10)**

### Meaning of “specified number” for the purposes of this Part

9.—(1) For the purposes of paragraph 7(2)(e), in relation to a particular vehicle (in this paragraph referred to as “the vehicle in question”) and a particular item [<sup>F649</sup>or provision], “the specified number” is [<sup>F650</sup>30%] of the total number of vehicles that—

- (a) are vehicles to which neither the Type Approval (Great Britain) Regulations nor the Type Approval for Goods Vehicles Regulations [<sup>F651</sup>nor the EC Whole Vehicle Type Approval Regulations] apply; and
  - (b) meet the requirements of sub-paragraph (2).
- (2) A vehicle meets the requirements of this paragraph if it—
- [<sup>F652</sup>(a) is a “vehicle” within the meaning of Community Directive 70/220 (as amended by Community Directive 83/351) or Community Directive 2005/55 (as amended by Community Directives 2005/78 and 2006/51);]
  - (b) was manufactured by the manufacturer of the vehicle in question; and
  - (c) was registered under the Vehicles (Excise) Act 1971 or the Vehicle Excise and Registration Act 1994 during the one year period ending immediately before the date specified in column 3 of that item [<sup>F653</sup>or, in relation to [<sup>F654</sup>any provision of any Community Directive specified in] item 1 or 2 of the Table in regulation 61A, before the date as is specified (as defined in regulation 61A) by the relevant Community Directive].

### Textual Amendments

- F649** Words in Sch. 7XA para. 9(1) inserted (20.10.2006) by The Road Vehicles (Construction and Use) and Motor Vehicles (Type Approval for Goods Vehicles) (Great Britain) (Amendment) Regulations 2006 (S.I. 2006/2565), regs. 1(2), **6(11)**
- F650** Figure in Sch. 7XA para. 9(1) replaced (20.10.2006) by The Road Vehicles (Construction and Use) and Motor Vehicles (Type Approval for Goods Vehicles) (Great Britain) (Amendment) Regulations 2006 (S.I. 2006/2565), regs. 1(2), **6(11)**
- F651** Words in Sch. 7XA para. 9(1)(a) inserted (20.10.2006) by The Road Vehicles (Construction and Use) and Motor Vehicles (Type Approval for Goods Vehicles) (Great Britain) (Amendment) Regulations 2006 (S.I. 2006/2565), regs. 1(2), **6(12)**
- F652** Sch. 7XA para. 9(2)(a) substituted (9.11.2006) by The Road Vehicles (Construction and Use) and Motor Vehicles (Type Approval for Goods Vehicles) (Great Britain) (Amendment) Regulations 2006 (S.I. 2006/2565), regs. 1(2), **6(13)**
- F653** Words in Sch. 7XA para. 9(2)(c) inserted (1.1.2001) by The Road Vehicles (Construction and Use) (Amendment) (No. 3) Regulations 2000 (S.I. 2000/3197), regs. 1, **8(8)**
- F654** Words in Sch. 7XA para. 9(2)(c) inserted (20.10.2006) by The Road Vehicles (Construction and Use) and Motor Vehicles (Type Approval for Goods Vehicles) (Great Britain) (Amendment) Regulations 2006 (S.I. 2006/2565), regs. 1(2), **6(14)**

### Circumstances in which a vehicle is to be regarded as having been in the territory of a relevant state for the purposes of this Part

10. Paragraph 5 in Part II of this Schedule shall have effect for the purposes of paragraph 7(2)(d) as it has effect for the purposes of paragraph 2(3)(c).

**Status:** This revised version has been created from an electronic version contributed by Westlaw which was originally derived from the printed publication. **Read more** (See end of Document for details)**Changes to legislation:** There are currently no known outstanding effects for the The Road Vehicles (Construction and Use) Regulations 1986. (See end of Document for details)

## Meaning of “relevant period” for the purposes of this Part

11. For the purposes of paragraphs 7(2)(d), “the relevant period”—
- (a) in relation to an item numbered 9 or 11 in Table II in regulation 61 is the period—
    - (i) beginning on the date specified in column 2 of the Table below against the item, and
    - (ii) ending immediately before the date specified in column 3 of the Table below against the item; and
  - (b) in relation to any item in the Table in regulation 55A or any item numbered 10 or higher (other than 11) in the said Table II is the two year period ending immediately before the date specified in column 3 of that item <sup>F655</sup>; and
  - (c) in relation to <sup>F656</sup>any provision of any Community Directive specified in] an item numbered 1 or 2 in the Table in regulation 61A is the two year period ending immediately before the date as is specified (as defined in regulation 61A) by the relevant Community Directive in the Table.]

**THE TABLE**

1	2	3	4
Item in Table II in regulation 61	Date on which relevant period begins	Date immediately before which the relevant period ends	Date in column 3 of Table II in regulation 61
9	1st April 1991	1st October 1993	1st October 1993
11	1st August 1992	1st August 1994	1st October 1994

### Textual Amendments

**F655** Sch. 7XA para. 11(c) and word inserted (1.1.2001) by [The Road Vehicles \(Construction and Use\) \(Amendment\) \(No. 3\) Regulations 2000 \(S.I. 2000/3197\)](#), regs. 1, **8(9)**

**F656** Words in Sch. 7XA para. 11(c) inserted (20.10.2006) by [The Road Vehicles \(Construction and Use\) and Motor Vehicles \(Type Approval for Goods Vehicles\) \(Great Britain\) \(Amendment\) Regulations 2006 \(S.I. 2006/2565\)](#), regs. 1(2), **6(15)**

## PART IV

### MEANING OF “LATE ENTRY INTO SERVICE VEHICLE” IN PART I

#### Meaning of “late entry into service vehicle” in paragraph 1

12. For the purposes of paragraph 1, a vehicle is a late entry into service vehicle, in relation to an item <sup>F657</sup>or provision], if—

- (a) no EC certificate of conformity has been issued in respect of the vehicle;
- (b) it was in the territory of a relevant state at some time before the date specified in column 3 of the item <sup>F658</sup>or, in relation to <sup>F659</sup>any provision of any Community Directive specified in] item 1 or 2 of the Table in regulation 61A, before the date as is specified (as defined in regulation 61A) by the relevant Community Directive];
- (c) it was manufactured at least two years before that date.

**Status:** Point in time view as at 31/03/2009.

**Status:** This revised version has been created from an electronic version contributed by Westlaw which was originally derived from the printed publication. **Read more** (See end of Document for details)**Changes to legislation:** There are currently no known outstanding effects for the The Road Vehicles (Construction and Use) Regulations 1986. (See end of Document for details)

**Textual Amendments**

- F657** Words in Sch. 7XA para. 12 inserted (20.10.2006) by The Road Vehicles (Construction and Use) and Motor Vehicles (Type Approval for Goods Vehicles) (Great Britain) (Amendment) Regulations 2006 (S.I. 2006/2565), regs. 1(2), **6(16)**
- F658** Words in Sch. 7XA para. 12(b) inserted (1.1.2001) by The Road Vehicles (Construction and Use) (Amendment) (No. 3) Regulations 2000 (S.I. 2000/3197), regs. 1, **8(10)**
- F659** Words in Sch. 7XA para. 12(b) inserted (20.10.2006) by The Road Vehicles (Construction and Use) and Motor Vehicles (Type Approval for Goods Vehicles) (Great Britain) (Amendment) Regulations 2006 (S.I. 2006/2565), regs. 1(2), **6(17)**

**Circumstances in which a vehicle is to be regarded as having been in the territory of a relevant state for the purposes of this Part**

**13.** Paragraph 5 in Part II of this Schedule shall have effect for the purposes of paragraph 12(b) as it has effect for the purposes of paragraph 2(3)(c).]

[<sup>F660</sup>SCHEDULE 7A

Regulations 57, 57A and 57B

MOTOR CYCLE NOISE AND MOTOR CYCLE SILENCERS

**Textual Amendments**

- F660** Sch. 7A inserted (1.7.1994) by The Road Vehicles (Construction and Use) (Amendment) Regulations 1994 (S.I. 1994/14), regs. 1(1), 3(8), **Sch. 2**

**PART I**

**1.—(1)** For the purposes of these Regulations a vehicle meets the requirements of an item in the Table below if its sound level does not exceed by more than 1 dB(A) the relevant limit specified in column 2 in that item when measured under the conditions specified in column 3 in that item by the method specified in column 4 in that item using the apparatus prescribed in regulation 55(6).

(2) In this Part of this Schedule, “moped” has the same meaning as in regulation 57.

**TABLE**

1	2	3	4
Item	Limits of sound level	Conditions of measurement	Methods of measurement
	Mopeds	Vehicles other than mopeds	
1	73 dB(A)	Limit determined in accordance with paragraph 2.1.1 of Annex I to Community Directive 78/1015 by reference to	Conditions specified in paragraph 2.1.3 of Annex I to Community Directive 78/1015
			Methods specified in paragraph 2.1.4 of Annex I to Community Directive 78/1015

**Status:** Point in time view as at 31/03/2009.

**Status:** This revised version has been created from an electronic version contributed by Westlaw which was originally derived from the printed publication. **Read more** (See end of Document for details)**Changes to legislation:** There are currently no known outstanding effects for the The Road Vehicles (Construction and Use) Regulations 1986. (See end of Document for details)

1	2	3	4
Item	Limits of sound level	Conditions of measurement	Methods of measurement
	Mopeds	Vehicles other than mopeds	
		the cubic capacity of the vehicle	
2	73 dB(A)	First stage limit determined in accordance with paragraph 2.1.1 of Annex I to Community Directive 87/56 by reference to the cubic capacity of the vehicle	Conditions specified in paragraph 2.1.3 of Annex I to Community Directive 87/56
			Methods specified in paragraph 2.1.4 of Annex I to Community Directive 87/56
3	74 dB(A)	The limit specified in item 2 plus 1 dB(A)	As in item 2

## PART II

2. The requirements of this paragraph are that the silencer—
  - (a) is so constructed that—
    - (i) it meets the requirements of paragraphs 3 and 4 of British Standard BS AU 193: 1983;
    - (ii) were it to be fitted to an unused vehicle of the same model as the vehicle in question, the unused vehicle would meet the requirements of paragraph 5.2 of that Standard; and
  - (b) is clearly and indelibly marked “BS AU 193/T2”.
3. The requirements of this paragraph are that the silencer—
  - (a) is so constructed that—
    - (i) it meets the requirements of paragraphs 3 and 4 of British Standard BS AU 193a: 1990;
    - (ii) were it to be fitted to an unused vehicle of the same model as the vehicle in question, the unused vehicle would meet the requirements of paragraph 5.2 of that Standard; and
  - (b) is clearly and indelibly marked “BS AU 193a: 1990/T2”
4. The requirements of this paragraph are that the silencer—
  - (a) is so constructed that—
    - (i) it meets the requirements of paragraphs 3 and 4 of British Standard BS AU 193a: 1990;
    - (ii) were it to be fitted to an unused vehicle of the same model as the vehicle in question, the unused vehicle would meet the requirements of paragraph 5.3 of that Standard; and

**Status:** Point in time view as at 31/03/2009.

**Status:** This revised version has been created from an electronic version contributed by Westlaw which was originally derived from the printed publication. **Read more** (See end of Document for details)**Changes to legislation:** There are currently no known outstanding effects for the The Road Vehicles (Construction and Use) Regulations 1986. (See end of Document for details)

(b) is clearly and indelibly marked “BS AU 193a: 1990/T3”.

5. In this Part of this Schedule—

- (a) “British Standard BS AU 193: 1983” means the British Standard Specification for replacement motor cycle and moped exhaust systems published by the British Standards Institution under reference number BS AU 193: 1983;
- (b) “British Standard BS AU 193a: 1990” means the British Standard Specification for replacement motor cycle and moped exhaust systems published by the British Standards Institution under reference number BS AU 193a: 1990.

### PART III

6. Paragraph (4) of regulation 57A shall not apply to a replacement silencer if the second requirement referred to in that regulation would be met were there substituted in Part II of this Schedule,—

- (a) for the references to provisions in either of the British Standard Specifications, references to equivalent provisions in a corresponding standard; and
- (b) for the references to a mark, references to a mark made pursuant to that corresponding standard indicating that the silencer complies with those equivalent provisions.

7. In this Part of this Schedule, “corresponding standard”, in relation to a British Standard Specification, means—

- (a) a standard or code of practice of a national standards body or equivalent body of any member State;
- (b) any international standard recognised for use as a standard by any member State; or
- (c) a technical specification or code of practice which, whether mandatory or not, is recognised for use as a standard by a public authority of any member State,

where the standard, code of practice, international standard or technical specification provides, in relation to motor cycles, a level of noise limitation and safety equivalent to that provided by the British Standard Specification and contains a requirement as respects the marking of silencers equivalent to that provided by that instrument.

8. A reference in this part of this Schedule to a British Standard Specification is a reference to British Standard BS AU 193: 1983 or British Standard BS AU 193a: 1990; and “either of the British Standard Specifications” shall be construed accordingly.

9. In this Part of this Schedule, “British Standard BS AU 193: 1983” and “British Standard BS AU 193a: 1990” have the same meanings as in Part II of this Schedule.]

[<sup>F661</sup>SCHEDULE 7B Regulation 61(10AA), (10AB) and (10BA)

### EMISSIONS FROM CERTAIN MOTOR VEHICLES

#### Textual Amendments

**F661** Sch. 7B inserted (25.9.1995) by The Road Vehicles (Construction and Use) (Amendment) (No. 5) Regulations 1995 (S.I. 1995/2210), regs. 1(2), 4, Sch. 2



**Status:** This revised version has been created from an electronic version contributed by Westlaw which was originally derived from the printed publication. **Read more** (See end of Document for details)**Changes to legislation:** There are currently no known outstanding effects for the The Road Vehicles (Construction and Use) Regulations 1986. (See end of Document for details)

## PART I

### VEHICLES PROPELLED BY SPARK IGNITION ENGINES

1. This Part of this Schedule applies to a vehicle if, when the engine is running without load at a normal idling speed, the carbon monoxide content of the exhaust emissions from the engine exceeds the relevant percentage of the total exhaust emissions from the engine by volume.

2. This Part of this Schedule also applies to a vehicle if, when the engine is running without load at a fast idling speed,—

- (a) the carbon monoxide content of the exhaust emissions from the engine exceeds [<sup>F662</sup>the relevant percentage] of the total exhaust emissions from the engine by volume;
- (b) the hydrocarbon content of those emissions exceeds 0.02% of the total exhaust emissions from the engine by volume; or
- (c) the lambda value is not within the relevant limits.

#### Textual Amendments

**F662** Words in Sch. 7B para. 2(a) substituted (1.3.2002) by The Road Vehicles (Construction and Use) (Amendment) Regulations 2002 (S.I. 2002/227), regs. 1, **2(2)**

3. For the purposes of [<sup>F663</sup>paragraph 1 of] this Part of this Schedule the relevant percentage, in respect of a vehicle, is—

- (a) if the vehicle is of a description specified in the Annex to the emissions publication, the percentage shown against that description of vehicle in column 2(a) of that Annex; <sup>F664</sup> ...
- [<sup>F665</sup>(b) if the vehicle is not of such a description and is first used before 1st July 2002, 0.5%; or
- (c) if the vehicle is not of such a description and is first used on or after 1st July 2002, 0.3%.]

#### Textual Amendments

**F663** Words in Sch. 7B para. 3 inserted (1.3.2002) by The Road Vehicles (Construction and Use) (Amendment) Regulations 2002 (S.I. 2002/227), regs. 1, **2(3)**

**F664** Word in Sch. 7B para. 3 omitted (1.1.2004) by virtue of The Road Vehicles (Construction and Use) (Amendment) (No. 5) Regulations 2003 (S.I. 2003/3145), regs. 1, **5(2)(a)**

**F665** Sch. 7B para. 3(b)(c) substituted for Sch. 7B para. 3(b) (1.1.2004) by The Road Vehicles (Construction and Use) (Amendment) (No. 5) Regulations 2003 (S.I. 2003/3145), regs. 1, **5(2)(b)**

[<sup>F666</sup>**3A.** For the purposes of paragraph 2(a) of this Part of this Schedule the relevant percentage, in respect of a vehicle, is, when the engine is running without load at a fast idling speed—

- (a) if the vehicle is of a description specified in the Annex to the emissions publication, the percentage shown against that description of vehicle in column 3(a) of that Annex; <sup>F667</sup> ...
- [<sup>F668</sup>(b) if the vehicle is not of such a description and is first used before 1st July 2002, 0.3%; or
- (c) if the vehicle is not of such a description and is first used on or after 1st July 2002, 0.2%.]

#### Textual Amendments

**F666** Sch. 7B para. 3A inserted (1.3.2002) by The Road Vehicles (Construction and Use) (Amendment) Regulations 2002 (S.I. 2002/227), regs. 1, **2(4)**

**Status:** Point in time view as at 31/03/2009.

**Status:** This revised version has been created from an electronic version contributed by Westlaw which was originally derived from the printed publication. **Read more** (See end of Document for details)**Changes to legislation:** There are currently no known outstanding effects for the The Road Vehicles (Construction and Use) Regulations 1986. (See end of Document for details)

**F667** Word in Sch. 7B para. 3A omitted (1.1.2004) by virtue of [The Road Vehicles \(Construction and Use\) \(Amendment\) \(No. 5\) Regulations 2003 \(S.I. 2003/3145\)](#), regs. 1, **5(3)(a)**

**F668** Sch. 7B para. 3A(b)(c) substituted for Sch. 7B para. 3A(b) (1.1.2004) by [The Road Vehicles \(Construction and Use\) \(Amendment\) \(No. 5\) Regulations 2003 \(S.I. 2003/3145\)](#), regs. 1, **5(3)(b)**

4. For the purposes of this Part of this Schedule, in the case of a vehicle of a description specified in the Annex to the emissions publication, the engine shall be regarded as running at a normal idling speed if and only if the engine is running at a rotational speed between the minimum and maximum limits shown against that description of vehicle in columns 2(b) and (c) respectively of that Annex.

5. For the purposes of this Part of this Schedule an engine shall be regarded as running at a fast idling speed if—

- (a) the vehicle is of a description specified in the Annex to the emissions publication and the engine is running at a rotational speed between the minimum and maximum limits shown against that description of vehicle in columns 3(e) and (f) respectively of that Annex; or
- (b) the vehicle is not of such a description and the engine is running at a rotational speed between 2,500 and 3,000 revolutions per minute.

6. For the purposes of this Part of this Schedule, the lambda value, in respect of a vehicle, shall be regarded as being within relevant limits, if and only if—

- (a) the vehicle is of a description specified in the Annex to the emissions publication and the lambda value is between the minimum and maximum limits shown against that description of vehicle in columns 3(c) and (d) respectively of that Annex; or
- (b) the vehicle is not of such a description and the lambda value is between 0.97 and 1.03.

7. In this Part of this Schedule—

- (a) a reference to the lambda value, in relation to a vehicle at any particular time, is a reference to the ratio by mass of air to petrol vapour in the mixture entering the combustion chambers divided by 14.7; and

[<sup>F669</sup>(b) “the emissions publication” is the publication entitled “In Service Exhaust Emission Standards for Road Vehicles – Twelfth Edition” (ISBN 0-9549352-1-7 on or before 31st December 2006 and from 1st January 2007 ISBN 978-09549352-1-4) published by the Department for Transport.]

#### Textual Amendments

**F669** Sch. 7B para. 7(b) substituted (1.8.2006) by [The Road Vehicles \(Construction and Use\) \(Amendment\) Regulations 2006 \(S.I. 2006/1756\)](#), regs. 1, **2(2)**

## PART II

### VEHICLES PROPELLED BY COMPRESSION IGNITION ENGINES

[<sup>F670</sup>8.—(1) This Part of this Schedule applies to a vehicle if, when subjected to a relevant test, the coefficient of absorption of the exhaust emissions from the engine of the vehicle immediately after leaving the exhaust system exceeds—

- (a) if the vehicle is first used before 1st July 2008 and the engine of that vehicle is turbo-charged, 3.0 per metre;

**Status:** Point in time view as at 31/03/2009.

**Status:** This revised version has been created from an electronic version contributed by Westlaw which was originally derived from the printed publication. **Read more** (See end of Document for details)**Changes to legislation:** There are currently no known outstanding effects for the The Road Vehicles (Construction and Use) Regulations 1986. (See end of Document for details)

- (b) if the vehicle is first used before 1st July 2008 and the engine of that vehicle is not turbo-charged, 2.5 per metre; or
  - (c) if the vehicle is first used on or after 1st July 2008, 1.5 per metre.
- (2) In paragraph (1) “a relevant test” means a test conducted in accordance with—
- (a) point 8.2.2 of Annex II of Council Directive 96/96/EC as replaced by Article 1 of Commission Directive 2003/27/EC; or
  - (b) point 2.2 of Annex II of Directive 2000/30/EC of the European Parliament and the Council as replaced by Article 1 of Commission Directive 2003/26/EC.]

**Textual Amendments**

**F670** Sch. 7B para. 8 substituted (1.1.2004) by [The Road Vehicles \(Construction and Use\) \(Amendment\) \(No. 5\) Regulations 2003 \(S.I. 2003/3145\)](#), regs. 1, **5(4)**

9. In this Part of this Schedule—

- (a) “coefficient of absorption” shall be construed in accordance with paragraph 3.5 of Annex VII to Community Directive 72/306; <sup>F671</sup>...
- <sup>F672</sup>(b) .....]

**Textual Amendments**

**F671** Word in Sch. 7B para. 9(a) omitted (1.10.2000) by virtue of [The Road Vehicles \(Construction and Use\) \(Amendment\) Regulations 2000 \(S.I. 2000/1434\)](#), regs. 1, **4(2)**

**F672** Sch. 7B para. 9(b) omitted (1.10.2000) by virtue of [The Road Vehicles \(Construction and Use\) \(Amendment\) Regulations 2000 \(S.I. 2000/1434\)](#), regs. 1, **4(2)**

SCHEDULE 8

(see regulation 66)

PLATES FOR CERTAIN VEHICLES

PART I

**Commencement Information**

**I153** Sch. 8 Pt. I in force at 11.8.1986, see [reg. 1](#)

Particulars to be shown on plate for motor vehicles (including motor vehicles forming part of articulated vehicles)

1. Manufacturer's name.
2. Vehicle type.
3. Engine type and power (a).
4. Chassis or serial number.
5. Number of axles.
6. Maximum axle weight for each axle (b).

**Status:** Point in time view as at 31/03/2009.

**Status:** This revised version has been created from an electronic version contributed by Westlaw which was originally derived from the printed publication. **Read more** (See end of Document for details) **Changes to legislation:** There are currently no known outstanding effects for the The Road Vehicles (Construction and Use) Regulations 1986. (See end of Document for details)

7. Maximum gross weight (c).
8. Maximum train weight (d).
9. Maximum weight in Great Britain for each axle (b) (e).
10. Maximum gross weight in Great Britain (c) (e).
  - (a) The power need not be shown in the case of a motor vehicle manufactured before 1st October 1972 (hereinafter in this Schedule referred to as “an excepted vehicle”) and shall not be shown in the case of any motor vehicle which is propelled otherwise than by a compression ignition engine.
  - (b) This weight as respects each axle is the sum of the weights to be transmitted to the road surface by all the wheels of that axle.
  - (c) This weight is the sum of the weights to be transmitted to the road surface by all the wheels of the motor vehicle (including any load imposed by a trailer, whether forming part of an articulated vehicle or not, on the motor vehicle).
  - (d) This weight is the sum of the weights to be transmitted to the road surface by all the wheels of the motor vehicle and of any trailer drawn, but this item need not be completed where the motor vehicle is not constructed to draw a trailer.
  - (b), (c), (d) References to the weights to be transmitted to the road surface by all or any of the wheels of the vehicle or of any trailer drawn are references to the weights so to be transmitted both of the vehicle or trailer and of any load or persons carried by it.
  - (e) This item need not be completed in the case of an excepted vehicle or in the case of a vehicle which is a locomotive or motor tractor.

## PART II

### Commencement Information

**I154** Sch. 8 Pt. II in force at 11.8.1986, see [reg. 1](#)

Particulars to be shown on plate for trailers (including trailers forming part of articulated vehicles)

1. Manufacturer's name.
2. Chassis or serial number.
3. Number of axles.
4. Maximum weight for each axle (a).
5. Maximum load imposed on drawing vehicle (b).
6. Maximum gross weight (c).
7. Maximum weight in Great Britain for each axle (a) (e).
8. Maximum gross weight in Great Britain (c) (f).
9. Year of manufacture (d).
  - (a) This weight as respects each axle is the sum of the weights to be transmitted to the road surface by all the wheels of that axle.
  - (b) Only for trailers forming part of articulated vehicles or where some of the weight of the trailer or its load is to be imposed on the drawing vehicle. This item need not be completed in the case of a converter dolly [<sup>F673</sup>manufactured before 1st February 1992]

**Status:** Point in time view as at 31/03/2009.

**Status:** This revised version has been created from an electronic version contributed by Westlaw which was originally derived from the printed publication. **Read more** (See end of Document for details)**Changes to legislation:** There are currently no known outstanding effects for the The Road Vehicles (Construction and Use) Regulations 1986. (See end of Document for details)

- (c) This weight is the sum of the weights to be transmitted to the road surface by all the wheels of the trailer, including any weight of the trailer to be imposed on the drawing vehicle.
- (a), (b), (c) References to the weights to be transmitted to the road surface by all or any of the wheels of the trailer are references to the weight so to be transmitted both of the trailer and of any load or persons carried by it and references to the weights to be imposed on the drawing vehicle are references to the weights so to be imposed both of the trailer and of any load or persons carried by it except where only the load of the trailer is imposed on the drawing vehicle.
- (d) This item need not be completed in the case of a trailer manufactured before 1st April 1970.
- (e) This item need not be completed in the case of a trailer manufactured before 1st October 1972.
- (f) This item need not be completed in the case of a trailer manufactured before 1st October 1972 or which forms part of an articulated vehicle.

#### Textual Amendments

**F673** Words in *Sch. 8 Pt. 2* added (1.11.1991) by *The Road Vehicles (Construction and Use) (Amendment) (No. 1) Regulations 1991 (S.I. 1991/1526)*, regs. 1, 4

### PART III

1. The power of an engine, which is to be shown only in the case of a compression ignition engine on the plate in respect of item 3 in Part I of this Schedule, shall be the amount in kilowatts equivalent to the installed power output shown in a type test certificate issued—

- (a) by a person authorised by the Secretary of State for the type of engine to which the engine conforms; and
- (b) in accordance with either—
  - (i) the provisions relating to the installed brake power output specified in the British Standard Specification for the Performance of Diesel Engines for Road Vehicles published on 19th May 1971 under the number BS AU 141a: 1971;
  - (ii) the provisions relating to the net power specified in Community Directive 80/1269 but after allowance has been made for the power absorbed by such equipment, at its minimum power setting, driven by the engine of the vehicle as is fitted for the operation of the vehicle (other than its propulsion) such power being measured at the speed corresponding to the engine speed at which maximum engine power is developed; or
  - (iii) the provisions of Annex 10 of ECE Regulation 24.02 as further amended with effect from 15th February 1984 [<sup>F674</sup>or Annex 10 of ECE Regulation 24.03 or Community Directive 88/195] relating to the method of measuring internal combustion engine net power, but after allowance has been made for the power absorbed by any disconnectable or progressive cooling fan, at its maximum setting, and by any other such equipment, at its minimum power setting, driven by the engine of the vehicle as is fitted for the operation of the vehicle (other than its propulsion), such power being measured at the speed corresponding to the engine speed at which maximum engine power is developed.

**Status:** Point in time view as at 31/03/2009.

**Status:** This revised version has been created from an electronic version contributed by Westlaw which was originally derived from the printed publication. **Read more** (See end of Document for details)**Changes to legislation:** There are currently no known outstanding effects for the The Road Vehicles (Construction and Use) Regulations 1986. (See end of Document for details)

### Textual Amendments

**F674** Words in Sch. 8 Pt. 3 para. 1(b)(iii) inserted (26.6.1990) by [The Road Vehicles \(Construction and Use\) \(Amendment\) \(No. 2\) Regulations 1990 \(S.I. 1990/1131\)](#), regs. 1, 5

### Commencement Information

**I155** Sch. 8 Pt. 3 para. 1 in force at 11.8.1986, see [reg. 1](#)

2.—(1) [<sup>F675</sup>Subject to paragraph 3A,] the weights to be shown on the plate in relation to items 6, 7 and 8 in Part I and in relation to items 4, 5 and 6 in Part II shall be the weight limits at or below which the vehicle is considered fit for use, having regard to its design, construction and equipment and the stresses to which it is likely to be subject in use, by the Secretary of State if the vehicle is one to which the Type Approval for Goods Vehicles Regulations [<sup>F676</sup>or the Motor Vehicles (Approval) Regulations 2001] apply, and by the manufacturer if the vehicle is one to which those Regulations do not apply.

Provided that, where alterations are made to a vehicle which may render the vehicle fit for use at weights which exceed those referred to above in this paragraph and shown on the plate—

- (a) there may be shown on the plate, in place of any of those weights, such new weights as the manufacturer of the vehicle or any person carrying on business as a manufacturer of motor vehicles or trailers (or a person duly authorised on behalf of that manufacturer or any such person) or a person authorised by the Secretary of State considers to represent the weight limits at or below which the vehicle will then be fit for use, having regard to its design, construction and equipment and to those alterations and to the stresses to which it is likely to be subject in use; and
- (b) the name of the person who has determined the new weights shall be shown on the plate as having made that determination and, where he is a person authorised by the Secretary of State, his appointment shall be so shown.

(2) In relation to a vehicle manufactured on or after 1st October 1972, in the foregoing paragraph

- (a) the references to equipment shall not be treated as including a reference to the type of tyres with which the vehicle is equipped; and
- (b) for the words “weight limits at or below” in both places where they occur there shall be substituted the words “maximum weights at”.

### Textual Amendments

**F675** Words in Sch. 8 Pt. 3 para. 2(1) inserted (1.3.2001) by [The Road Vehicles \(Construction and Use\) \(Amendment\) Regulations 2001 \(S.I. 2001/306\)](#), regs. 1, **4(1)(a)**

**F676** Words in Sch. 8 Pt. 3 para. 2(1) inserted (1.3.2001) by [The Road Vehicles \(Construction and Use\) \(Amendment\) Regulations 2001 \(S.I. 2001/306\)](#), regs. 1, **4(1)(b)**

### Commencement Information

**I156** Sch. 8 Pt. III para. 2 in force at 11.8.1986, see [reg. 1](#)

3. [<sup>F677</sup>Subject to paragraph 3A,] the weights to be shown on the plate in respect of—

- (a) item 9 in Part I of this Schedule shall be the weights shown at item 6 in that Part and in respect of item 7 in Part II of this Schedule shall be the weights shown at item 4 in that Part, in each case reduced so far as necessary to indicate the maximum weight applicable to each

**Status:** Point in time view as at 31/03/2009.

**Status:** This revised version has been created from an electronic version contributed by Westlaw which was originally derived from the printed publication. **Read more** (See end of Document for details)**Changes to legislation:** There are currently no known outstanding effects for the The Road Vehicles (Construction and Use) Regulations 1986. (See end of Document for details)

axle of the vehicle, if the vehicle is not to be used in contravention of regulations 23, 75, 78 or 79, and if the tyres with which the vehicle is equipped are not, as respects strength, to be inadequate to support the weights to be so shown at item 9 and item 7;

- (b) item 10 in the said Part I shall be the weight shown at item 7 in that Part and in respect of item 8 in the said Part II shall be the weight shown at item 6 in that Part, in each case reduced so far as necessary to indicate the maximum permissible weight applicable if the vehicle is not to be used in contravention of regulation 75 if the tyres with which the vehicle is equipped are not, as respects strength, to be inadequate to support the weights to be so shown at item 10 and item 8.

#### Textual Amendments

**F677** Words in Sch. 8 Pt. 3 para. 3 inserted (1.3.2001) by [The Road Vehicles \(Construction and Use\) \(Amendment\) Regulations 2001 \(S.I. 2001/306\)](#), regs. 1, **4(2)**

#### Commencement Information

**I157** [Sch. 8 Pt. III para. 3](#) in force at 11.8.1986, see [reg. 1](#)

[<sup>F678</sup>**3A.** In the case of a vehicle—

- (a) which complies with the requirements specified in regulation 4(2) of the Motor Vehicles (Approval) Regulations 2001;
- (b) in respect of which a Minister’s approval certificate has been issued under section 58 of the 1988 Act for the purposes of the type approval requirements prescribed by those Regulations; and
- (c) in respect of which a Minister’s approval certificate has not subsequently been issued under that section for the purposes of the type approval requirements prescribed by the Type Approval for Goods Vehicles Regulations,

the weight shown on the plate in relation to items 7 and 10 in Part I of this Schedule shall be 3,500 kg.]

#### Textual Amendments

**F678** [Sch. 8 Pt. 3 para. 3A](#) inserted (1.3.2001) by [The Road Vehicles \(Construction and Use\) \(Amendment\) Regulations 2001 \(S.I. 2001/306\)](#), regs. 1, **4(3)**

**4.—**(1) Subject to sub-paragraph (2) of this paragraph weights on plates first affixed to a vehicle on or after 1st October 1972 shall be shown in kilograms and weights on plates first so affixed before that date shall be shown in tons and decimals thereof.

(2) Where a new weight is first shown on a plate by virtue of the proviso to paragraph 2(1) the weight shall be shown as if it was on a plate first affixed to a vehicle on the date it was first shown.

#### Commencement Information

**I158** [Sch. 8 Pt. III para. 4](#) in force at 11.8.1986, see [reg. 1](#)

**5.** All letters and figures shown on the plate shall be not less than 6mm in height.

**Status:** Point in time view as at 31/03/2009.

**Status:** This revised version has been created from an electronic version contributed by Westlaw which was originally derived from the printed publication. **Read more** (See end of Document for details)**Changes to legislation:** There are currently no known outstanding effects for the The Road Vehicles (Construction and Use) Regulations 1986. (See end of Document for details)

**Commencement Information**  
**I159** Sch. 8 Pt. III para. 5 in force at 11.8.1986, see reg. 1

6. In this Schedule references to the manufacturer of a motor vehicle or trailer are in relation to—
- (a) a vehicle constructed with a chassis which has not previously formed part of another vehicle, references to the person by whom that chassis was made;
  - (b) any other vehicle, references to the person by whom that vehicle was constructed.

**Commencement Information**  
**I160** Sch. 8 Pt. III para. 6 in force at 11.8.1986, see reg. 1

SCHEDULE 9

(see regulation 69)

PLATES FOR MOTOR CYCLES

1. The plate required by regulation 69 shall be firmly attached to a part of the motor cycle which is not normally subject to replacement during the life of the motor cycle.

**Commencement Information**  
**I161** Sch. 9 para. 1 in force at 11.8.1986, see reg. 1

2. The plate shall be in the form shown in the diagram in this paragraph, shall have dimensions not less than those shown in that diagram and shall show the information provided for in that diagram and detailed in the Notes below.

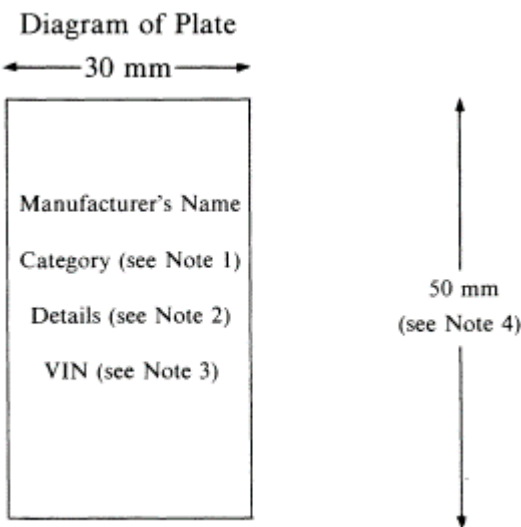

Notes:

1. The categories are “standard motor cycle” and “moped”.



**Status:** Point in time view as at 31/03/2009.

**Status:** This revised version has been created from an electronic version contributed by Westlaw which was originally derived from the printed publication. **Read more** (See end of Document for details)**Changes to legislation:** There are currently no known outstanding effects for the The Road Vehicles (Construction and Use) Regulations 1986. (See end of Document for details)

2. The details are—
  - (a) for standard motor cycles—
    - (i) the engine capacity,
    - (ii) the maximum engine power, and
    - (iii) the power to weight ratio,
  - (b) provided that the details under (ii) and (iii) need not be shown for a vehicle first used before 1st January 1982;
  - (b) for mopeds—
    - (i) the engine capacity,
    - (ii) the kerbside weight, and
    - (iii) the maximum speed.
3. The vehicle identification number (VIN) shall be marked in the form used by the manufacturer to identify any one individual vehicle.
4. In the case of a plate fitted to a vehicle first used before 1st January 1982 or to a moped this dimension shall be 40 mm.

**Commencement Information**

**I162** Sch. 9 para. 2 in force at 11.8.1986, see [reg. 1](#)

3. The information on the plate shall be shown in characters not less than 4 mm in height and in the positions on the plate indicated in the diagram above.

**Commencement Information**

**I163** Sch. 9 para. 3 in force at 11.8.1986, see [reg. 1](#)

4. No information, other than that provided for in the diagram above, shall be marked within the rectangle which is shown in that diagram.

**Commencement Information**

**I164** Sch. 9 para. 4 in force at 11.8.1986, see [reg. 1](#)

5. In this Schedule and, in respect of the definition of “moped”, in regulations 54 and 57—

“maximum engine power” means the maximum net power the motor cycle engine will develop, in kilowatts, when measured in accordance with the test conditions specified in the International Standard number ISO 4106 developed by the technical committee of the International Organisation for Standardisation, and approved by member bodies, including the United Kingdom, and published under the reference ISO 1978 4106–09–01;

“moped” means a motor cycle which—

  - (a) has a kerbside weight not exceeding 250 kg, and
  - (b) if propelled by an internal combustion engine, has an engine with a cylinder capacity which does not exceed 50 cc, and
  - (c) is designed to have a maximum speed not exceeding 30 mph when driven under the conditions set out in paragraph 6.

**Status:** Point in time view as at 31/03/2009.

**Status:** This revised version has been created from an electronic version contributed by Westlaw which was originally derived from the printed publication. **Read more** (See end of Document for details)**Changes to legislation:** There are currently no known outstanding effects for the The Road Vehicles (Construction and Use) Regulations 1986. (See end of Document for details)

“power to weight ratio” means the ratio of the maximum engine power to the kerbside weight of the vehicle measured, as regards the maximum engine power, in kilowatts and, as regards the kerbside weight, in 1000 kg;

“standard motor cycle” means a motor cycle which is not a moped.

**Commencement Information**

**I165** Sch. 9 para. 5 in force at 11.8.1986, see **reg. 1**

**6.** A motor cycle shall regarded as complying with paragraph (c) of the definition of “moped” in paragraph 5 if it cannot exceed 35 mph when tested under the following conditions—

- (a) the surface on which it is tested shall be dry asphalt or concrete;
- (b) the rider shall be a person not exceeding 75 kg in weight;
- (c) no passenger or load shall be carried;
- (d) the test route shall be so located that acceleration to, and deceleration from, maximum speed can take place elsewhere than on the test route itself;
- (e) the test route shall not have a gradient exceeding 5%;
- (f) the motor cycle shall be ridden in opposite directions along the test route and the speed recorded for the purpose of the test shall (in order to minimise the effect of wind resistance and gradient) be the average of speeds shown for each direction;
- (g) when being driven along the test route, the motor cycle shall be driven in such manner and in such gear as to achieve the maximum speed of which it is capable; and
- (h) if the motor cycle is fitted with a device which can, without the use of specialist tools or equipment, be readily modified or removed so as to increase its maximum speed, the test shall be carried out with the device in the modified condition or, as the case may be, without the device.

**Commencement Information**

**I166** Sch. 9 para. 6 in force at 11.8.1986, see **reg. 1**

SCHEDULE 10

(see regulation 70)

MINISTRY PLATE

**Commencement Information**

**I167** Sch. 10 in force at 11.8.1986, see **reg. 1**

**Status:** Point in time view as at 31/03/2009.

**Status:** This revised version has been created from an electronic version contributed by Westlaw which was originally derived from the printed publication. **Read more** (See end of Document for details)**Changes to legislation:** There are currently no known outstanding effects for the The Road Vehicles (Construction and Use) Regulations 1986. (See end of Document for details)

**SCHEDULE 10 (see regulation 70)  
MINISTRY PLATE**

DEPARTMENT OF TRANSPORT Road Traffic Act 1972, Sections 40 and 47 Examination of Goods Vehicles				Serial No.
PLATE				DTP REF. NO.
REGISTRATION/IDENTIFICATION MARK	YEAR OF ORIGINAL REGISTRATION	YEAR OF MANUFACTURE	FUNCTION	MAKE AND MODEL
CHASSIS/SERIAL No.		UNLADEN WEIGHT		
(1) DESCRIPTION OF WEIGHTS APPLICABLE TO VEHICLE	(2) WEIGHTS NOT TO BE EXCEEDED IN GREAT BRITAIN		(3) DESIGN WEIGHTS (if higher than shown in col (2))	
	KILOGRAMS		KILOGRAMS	
	AXLE 1			
	AXLE 2			
	AXLE 3			
GROSS WEIGHT (see warning opposite)				DATE OF ISSUE
TRAIN WEIGHT (see warning opposite)				WARNING

Notes: 1. A Ministry plate may contain the words "MINISTRY OF TRANSPORT" or "DEPARTMENT OF THE ENVIRONMENT" instead of the words "DEPARTMENT OF TRANSPORT", and may contain the words "Road Safety Act 1967, Sections 8 and 9" or of the words "Road Traffic Act 1972, Sections 40 and 45", (in a case where the Type Approval For Goods Vehicles Regulations do not apply). It may also contain additional columns in Columns (2) and (3) showing the weights in tons.  
 2. Entries in respect of train weight are required in the case of— (a) a motor vehicle constructed or adapted to form part of an articulated vehicle; and (b) a rigid vehicle which is constructed or adapted to draw a trailer and is first used on or after 1st April 1983.  
 3. A Ministry plate shows the unladen weight and function of the vehicle in a case where the Type Approval for Goods Vehicles Regulations apply.  
 4. A Ministry plate may have separate spaces for the "make" and "model" of the vehicle.  
 5. A Ministry plate may have no "Reference Number" or may refer to the "Department of the Environment Reference No."

**Status:** Point in time view as at 31/03/2009.

**Status:** This revised version has been created from an electronic version contributed by Westlaw which was originally derived from the printed publication. **Read more** (See end of Document for details)**Changes to legislation:** There are currently no known outstanding effects for the The Road Vehicles (Construction and Use) Regulations 1986. (See end of Document for details)

[<sup>F679</sup>SCHEDULE 10A

MINISTRY PLATE]

**Textual Amendments**

**F679** Sch. 10A inserted (6.5.1987) by The Road Vehicles (Construction and Use) (Amendment) Regulations 1987 (S.I. 1987/676), reg. 1(2), **Sch.**

**Status:** Point in time view as at 31/03/2009.

**Status:** This revised version has been created from an electronic version contributed by Westlaw which was originally derived from the printed publication. **Read more** (See end of Document for details)**Changes to legislation:** There are currently no known outstanding effects for the The Road Vehicles (Construction and Use) Regulations 1986. (See end of Document for details)

SCHEDULE 10A (see regulation 70)  
MINISTRY PLATE

PLATE VTG 6A		DEPARTMENT OF TRANSPORT Road Traffic Act 1972. Sections 40, 45 and 47 Examination of Goods Vehicles		SERIAL NUMBER		
				UNLADEN WEIGHT	DTp REF No	
				5. VEHICLE DIMENSIONS		
REGISTRATION/ IDENTIFICATION MARK	YEAR OF ORIGINAL REG	YEAR OF MANUFACTURE	FUNCTION	LENGTH (L)		
				WIDTH (W)		
MANUFACTURER/MODEL				a. (See Note 1) COUPLING CENTRE TO VEHICLE FOREMOST PART	MAXIMUM	MINIMUM
TYPE APPROVAL/ VARIANT No				b. (See Note 2) COUPLING CENTRE TO VEHICLE REARMOST PART		
VEHICLE IDENTIFICATION No						
(1) DESCRIPTION OF WEIGHTS APPLICABLE TO VEHICLE	(2) WEIGHT NOT TO BE EXCEEDED IN Gt. BRITAIN	(3) EEC MAXIMUM PERMITTED WEIGHTS (See Note 4)	(4) DESIGN WEIGHTS (if higher than shown in column 2)		MAXIMUM	MINIMUM
GROSS WEIGHT (See warning below)						
TRAIN WEIGHT (See warning below)				DATE OF ISSUE		
MAXIMUM TRAIN WEIGHT (See Note 3)						
AXLE WEIGHTS (Axles numbered from front to rear)						
Axle 1						
Axle 2						
Axle 3						
Axle 4						
MAXIMUM KINGPIN LOAD (Semi-trailers only)						
N.B. ALL WEIGHTS IN KILOGRAMS/ALL DIMENSIONS IN MILLIMETRES.						
<b>WARNING</b>						
a. A reduced gross weight may apply in certain cases to a vehicle towing or being towed by another.						
b. A reduced train weight may apply depending on the type of trailer drawn.						
c. All weights shown are subject to the fitting of correct tyres.						
<b>NOTES</b>						
1. This dimension only applies to drawing vehicles of trailers and semi-trailers.						
2. This dimension only applies to trailers and semi-trailers.						
3. This weight only applies to a 3 axle tractor with a 2 or 3 axle semi-trailer carrying a 40 foot ISO container as a combined transport operation.						
4. Where there is no weight shown in the EEC maximum permitted weights column this is because there is no EEC standard relating to that weight.						

**NOTES**

- Entries in respect of train weight are required in the case of – (a) a motor vehicle constructed or adapted to form an articulated vehicle; and (b) a rigid vehicle which is constructed or adapted to draw a trailer and is first used on or after 1st April 1983.
- A Ministry plate shows the unladen weight and function of the vehicle in a case where the Type Approval for Goods Vehicles Regulations apply.
- A Ministry plate may have no 'Reference Number'.

Status: Point in time view as at 31/03/2009.

Status: This revised version has been created from an electronic version contributed by Westlaw which was originally derived from the printed publication. **Read more** (See end of Document for details)**Changes to legislation:** There are currently no known outstanding effects for the The Road Vehicles (Construction and Use) Regulations 1986. (See end of Document for details)

[F680] SCHEDULE 10B

(see Regulation 3(2))

**Textual Amendments**

F680 Sch. 10B inserted (24.3.1994) by The Road Vehicles (Construction and Use) (Amendment) (No. 2) Regulations 1994 (S.I. 1994/329), regs. 1, 10, Sch. 1

Department of Transport ROAD TRAFFIC ACT 1986 SECTIONS 41, 49, 57 & 58 EXAMINATION OF GOODS VEHICLES		Serial No. <b>V</b>	
Plate <b>VTG 6T</b> Rev. 92		DTp Ref. No.	
Reg./Ident. Mark	Vehicle Identification No.		Type Approval No./Variant
Manufacturer/Model			Speed Limiter Exempt
Function <i>(See note 3 below)</i>		Year of Original Registration	Year of Manufacture
(1) Description of Weights applicable to vehicle	(2) Weights not to be exceeded in G.I. Britain	(3) Design Weights <i>(If higher than shown in column 2)</i>	Date of Issue 
Gross Weight <i>(See notes 1 &amp; 4 below)</i>			
Train Weight <i>(See note 2 below)</i>			
Max. Train Weight <i>(See note 5 below)</i>			
Axle Weights <i>(Axes numbered from front to rear) (See note 1 overleaf)</i>	Axle 1		
	Axle 2		
	Axle 3		
	Axle 4		
<b>NOTES</b> 1. A reduced gross weight and/or axle weight may apply in certain cases to a vehicle towing or being towed by another. 2. The MAXIMUM permissible train weight can vary depending on the type of suspension and trailer drawn. 3. If the last letter in the function box is 'R' road friendly suspension is fitted. 4. All weights shown are subject to the fitting of correct tyres. 5. This weight applies to combined transport operations.			Tyre use conditions applicable to vehicle  N.B. All Weights in Kilograms

Note: A weight is not required in the box for Maximum Train Weight unless the vehicle is capable of being lawfully used on a road in Great Britain, having regard to Schedule 11A, at a greater train weight than the train weight at which it could lawfully be used ignoring that Schedule.]

Status: Point in time view as at 31/03/2009.

Status: This revised version has been created from an electronic version contributed by Westlaw which was originally derived from the printed publication. Read more (See end of Document for details) Changes to legislation: There are currently no known outstanding effects for the The Road Vehicles (Construction and Use) Regulations 1986. (See end of Document for details)

[F681] SCHEDULE 10C

(see Regulation 3(2))

Textual Amendments

F681 Sch. 10C inserted (24.3.1994) by The Road Vehicles (Construction and Use) (Amendment) (No. 2) Regulations 1994 (S.I. 1994/329), regs. 1, 10, Sch. 2

Department of Transport ROAD TRAFFIC ACT 1986 SECTIONS 41, 49, 57 & 58 EXAMINATION OF GOODS VEHICLES This is issued as proof of compliance with the Weights and Dimensions Directive 86/253/EEC		Serial No. <b>B</b>	
Plate <b>VTG 6A</b>		DTp Ref. No.	
Reg./Ident. Mark		Vehicle Identification No.	
Manufacturer/Model		Type Approval No./Variant	
Function (See note 3 below)		Year of Original Registration	
Year of Manufacture		Speed Limiter Exempt	
(1) Description of Weights applicable to vehicle	(2) Weights not to be exceeded in Gt. Britain	(3) EEC Maximum permitted weights (See note 8 below)	(4) Design Weights (If higher than shown in column 2)
Gross Weight (See notes 1 & 4 below)		Length	
Train Weight (See note 2 below)		Width	
Max Train Weight (See note 5 below)		Date of Issue	
Axle Weights (Axles numbered from front to rear) (See note 7 below)		DEPARTMENT OF TRANSPORT GREAT BRITAIN	
Maximum Kingpin Load (Semi-trailers only)		Tyre use conditions applicable to vehicle	
NOTES (Cont'd)			
5. This weight applies to combined transport operations. 6. This dimension only applies to drawing vehicles of trailers and semi-trailers. 7. This dimension only applies to trailers and semi-trailers. 8. Where there is no weight shown in the EEC maximum permitted weights column this is because there is no EEC standard relating to that weight. N.B. All Weights in Kilograms-All Dimensions in Millimetres			
NOTES 1. A reduced gross weight and/or axle weight may apply in certain cases to a vehicle towing or being towed by another. 2. The maximum permissible train weight can vary depending on the type of suspension and trailer design. 3. If the last letter in the function box is 'R' road friendly suspension is fitted. 4. All weights shown are subject to the fitting of correct tyres.			

Note: A weight is not required in the box for Maximum Train Weight unless the vehicle is capable of being lawfully used on a road in Great Britain, having regard to Schedule 11A, at a greater train weight than the train weight at which it could lawfully be used ignoring that Schedule.]

**Status:** Point in time view as at 31/03/2009.

**Status:** This revised version has been created from an electronic version contributed by Westlaw which was originally derived from the printed publication. **Read more** (See end of Document for details)**Changes to legislation:** There are currently no known outstanding effects for the The Road Vehicles (Construction and Use) Regulations 1986. (See end of Document for details)

SCHEDULE 11

(see regulations 75, 77 and 79)

MAXIMUM PERMITTED WEIGHTS, ETC

<sup>F682</sup>PART I (see regulation 75)

MAXIMUM PERMITTED LADEN WEIGHTS OF (1) TRAILERS AND (2) HEAVY MOTOR CARS AND MOTOR CARS NOT FITTED WITH ROAD FRIENDLY SUSPENSION; IN EACH CASE NOT FORMING PART OF AN ARTICULATED VEHICLE

**Textual Amendments**

**F682** Sch. 11 Pt. 1 substituted (1.1.1993) by [The Road Vehicles \(Construction and Use\) \(Amendment\) \(No. 4\) Regulations 1992 \(S.I. 1992/2016\)](#), regs. 1, 10(a), **Sch. 2 Pt. I**

1. The maximum permitted laden weight of a two or three axle vehicle to which this Part applies of a description specified in column 2 of Table I below shall, for the purposes of regulation 75, be the weight specified in column 3 of that item.

2. In the case of a vehicle to which this Part applies and which is not of a description specified in an item in column 2 of Table I below, the maximum permitted laden weight shall, for the purposes of regulation 75, be the weight specified in column 4 of Table II below in the item which is appropriate having regard to columns 2 and 3 of that Table.

**TABLE I**

MAXIMUM PERMITTED LADEN WEIGHTS OF CERTAIN TWO AND THREE AXLE VEHICLES

(1) Item	(2) Description of Vehicle	(3) Maximum permitted laden weight (kg)
1	A two axle trailer in which— (a) the two axles are closely spaced, and (b) the distance between the foremost axle of the trailer and the rearmost axle of the drawing vehicle is at least 4.2m	18,000
2	A three axle trailer in which— (a) the three axles are closely spaced, and (b) the distance between the foremost axle of the trailer and the rearmost axle of the drawing vehicle is at least 4.2m	24,000



**Status:** Point in time view as at 31/03/2009.

**Status:** This revised version has been created from an electronic version contributed by Westlaw which was originally derived from the printed publication. **Read more** (See end of Document for details)**Changes to legislation:** There are currently no known outstanding effects for the The Road Vehicles (Construction and Use) Regulations 1986. (See end of Document for details)

(1) Item	(2) Description of Vehicle	(3) Maximum permitted laden weight (kg)
3	A two axle motor vehicle which is a goods vehicle in which the distance between the foremost and rearmost axles is at least 3.0m	17,000
4	A two axle trailer in which the distance between the foremost axle and the rearmost axle is at least 3.0m	18,000

**TABLE II**

MAXIMUM PERMITTED LADEN WEIGHTS OF  
VEHICLES NOT FALLING WITHIN TABLE I

(1) Item	(2) No. of axles	(3) Distance between foremost and rearmost axles (metres)	(4) Maximum permitted laden weight (kg)
1	2	Less than 2.65	14,230
2	2	At least 2.65	16,260
3	3 or more	Less than 3.0	16,260
4	3 or more	At least 3.0 but less than 3.2	18,290
5	3 or more	At least 3.2 but less than 3.9	20,330
6	3 or more	At least 3.9 but less than 4.9	22,360
7	3	At least 4.9	25,000
8	4 or more	At least 4.9 but less than 5.6	25,000
9	4 or more	At least 5.6 but less than 5.9	26,420
10	4 or more	At least 5.9 but less than 6.3	28,450
11	4 or more	At least 6.3	30,000]

**Status:** Point in time view as at 31/03/2009.

**Status:** This revised version has been created from an electronic version contributed by Westlaw which was originally derived from the printed publication. **Read more** (See end of Document for details)**Changes to legislation:** There are currently no known outstanding effects for the The Road Vehicles (Construction and Use) Regulations 1986. (See end of Document for details)

## [<sup>F683</sup>PART IA (see regulation 75)

### MAXIMUM PERMITTED GROSS WEIGHTS FOR HEAVY CARS AND MOTOR CARS IF THE DRIVING AXLES ARE FITTED WITH ROAD FRIENDLY SUSPENSION ETC AND IN EACH CASE NOT FORMING PART OF AN ARTICULATED VEHICLE

#### Textual Amendments

**F683** Sch. 11 Pt. 1A inserted (1.1.1993) by [The Road Vehicles \(Construction and Use\) \(Amendment\) \(No. 4\) Regulations 1992 \(S.I. 1992/2016\)](#), regs. 1, 10(b), **Sch. 2 Pt. II**

1. Subject to paragraph 2, the maximum permitted gross weight of a vehicle to which this Part applies shall, for the purposes of regulation 75, be the weight shown in column 4 of the Table below in the item which is appropriate, having regard to columns 2 and 3 in that Table.

2. In the case of a vehicle to which this Part applies being a two axle goods vehicle which has a distance between its axles of at least 3.0m, the maximum permitted laden weight for the purposes of regulation 75 shall be 17,000 kg.

#### TABLE

##### MAXIMUM PERMITTED LADEN WEIGHT

(1) Item	(2) No. of axles	(3) Distance between foremost and rearmost axles (metres)	(4) Maximum permitted laden weight (kg)
1	2	Less than 2.65	14,230
2	2	At least 2.65	16,260
3	3 or more	Less than 3.0	16,260
4	3 or more	At least 3.0 but less than 3.2	18,290
5	3 or more	At least 3.2 but less than 3.9	20,330
6	3 or more	At least 3.9 but less than 4.9	22,360
7	3 or more	At least 4.9 but less than 5.2	25,000
8	3	At least 5.2	26,000
9	4 or more	At least 5.2 but less than 6.4	The distance in metres between the foremost and rearmost axles multiplied by 5,000, rounded up to the next 10 kg

**Status:** Point in time view as at 31/03/2009.

**Status:** This revised version has been created from an electronic version contributed by Westlaw which was originally derived from the printed publication. **Read more** (See end of Document for details)**Changes to legislation:** There are currently no known outstanding effects for the The Road Vehicles (Construction and Use) Regulations 1986. (See end of Document for details)

(1) Item	(2) No. of axles	(3) Distance between foremost and rearmost axles (metres)	(4) Maximum permitted laden weight (kg)
10	4 or more	At least 6.4	32,000]

(see regulation 75)

## PART II

### Maximum permitted laden weights for heavy motor cars and motor cars forming part of articulated vehicles

#### Commencement Information

**I168** Sch. 11 Pt. II in force at 11.8.1986, see [reg. 1](#)

<i>1</i> Item	<i>2</i> No. of axles	<i>3</i> Distance between foremost and rearmost axles (metres)	<i>4</i> Weight not exceeded by any axle not being the foremost or rearmost (kg)	<i>5</i> Maximum permitted laden weight (kg)
1	2	At least 2.0	—	14,230
2	2	At least 2.4	—	16,260
3	2	At least 2.7	—	17,000 F684
				...
4	3 or more	At least 3.0	8,390	20,330
5	3 or more	At least 3.8	8,640	22,360
6	3 or more	At least 4.0	10,500	22,500
7	3 or more	At least 4.3	9,150	24,390
8	3 or more	At least 4.9	10,500	24,390

#### Textual Amendments

**F684** Words in [Sch. 11 Pt. II](#) omitted (1.4.1988) by virtue of [The Road Vehicles \(Construction and Use\) \(Amendment\) Regulations 1987 \(S.I. 1987/676\)](#), regs. 1(2), **13(2)(b)**

(see regulation 77)

**Status:** Point in time view as at 31/03/2009.

**Status:** This revised version has been created from an electronic version contributed by Westlaw which was originally derived from the printed publication. **Read more** (See end of Document for details)**Changes to legislation:** There are currently no known outstanding effects for the The Road Vehicles (Construction and Use) Regulations 1986. (See end of Document for details)

## PART III

### Maximum permitted laden weight of articulated vehicles

#### Commencement Information

**I169** Sch. 11 Pt. III in force at 11.8.1986, see **reg. 1**

<i>1</i>	<i>2</i>		<i>3</i>	<i>F685</i>
<i>Item</i>	<i>Relevant axle spacing (metres)</i>		<i>Maximum weight (kg)</i>	...
	<i>(a) Where motor vehicle has 2 axles</i>	<i>(b) Where motor vehicle has more than 2 axles</i>		
1	At least 2.0	At least 2.0	20,330	
2	At least 2.2	At least 2.2	22,360	
3	At least 2.6	At least 2.6	23,370	
4	At least 2.9	At least 2.9	24,390	
5	At least 3.2	At least 3.2	25,410	
6	At least 3.5	At least 3.5	26,420	
7	At least 3.8	At least 3.8	27,440	
8	At least 4.1	At least 4.1	28,450	
9	At least 4.4	At least 4.4	29,470	
10	At least 4.7	At least 4.7	30,490	
11	At least 5.0	At least 5.0	31,500	
12	At least 5.3	At least 5.3	32,520	
13	At least 5.5	At least 5.4	33,000	
14	At least 5.8	At least 5.6	34,000	
15	At least 6.2	At least 5.8	35,000	
16	At least 6.5	At least 6.0	36,000	
17	At least 6.7	At least 6.2	37,000	
18	At least 6.9	At least 6.3	38,000	

#### Textual Amendments

**F685** Words in Sch. 11 Pt. III omitted (24.3.1994) by virtue of The Road Vehicles (Construction and Use) (Amendment) (No. 2) Regulations 1994 (S.I. 1994/329), regs. 1, **11(2)**

**Status:** This revised version has been created from an electronic version contributed by Westlaw which was originally derived from the printed publication. **Read more** (See end of Document for details)**Changes to legislation:** There are currently no known outstanding effects for the The Road Vehicles (Construction and Use) Regulations 1986. (See end of Document for details)

## [<sup>F686</sup>PART IV (see regulation 77)

### MAXIMUM PERMITTED LADEN WEIGHT OF ARTICULATED VEHICLES

#### Textual Amendments

**F686** Sch. 11 Pt. 4 substituted (1.1.1993) by The Road Vehicles (Construction and Use) (Amendment) (No. 4) Regulations 1992 (S.I. 1992/2016), regs. 1, 10(c), **Sch. 2 Pt. III**

(1) Item	(2) Type of articulated vehicle	(3) Maximum permitted weight (kg)
1	Motor vehicle first used on or after 1st April 1973 and semi-trailer having a total of 5 or more axles	38,000
2	Motor vehicle with 2 axles first used on or after 1st April 1973 and semi-trailer with 2 axles while being used for international transport	35,000
3	Motor vehicle with 2 axles first used on or after 1st April 1973 in which— (a) every driving axle not being a steering axle is fitted with twin tyres; and (b) every driving axle is fitted with road friendly suspension; and a semi-trailer with 2 axles	35,000
4	[ <sup>F687</sup> Motor vehicle and semi-trailer having a total of 4 or more axles and not described in item 1, 2 or 3.]	32,520
5	Motor vehicle with 2 axles first used on or after 1st April 1973 in which— (a) every driving axle not being a steering axle is fitted with twin tyres; and (b) every driving axle is fitted with road friendly suspension; and a semi-trailer with 1 axle	26,000
6	Motor vehicle with 2 axles and a semi-trailer with 1 axle being	25,000]

**Status:** Point in time view as at 31/03/2009.

**Status:** This revised version has been created from an electronic version contributed by Westlaw which was originally derived from the printed publication. **Read more** (See end of Document for details)**Changes to legislation:** There are currently no known outstanding effects for the The Road Vehicles (Construction and Use) Regulations 1986. (See end of Document for details)

(1) Item	(2) Type of articulated vehicle	(3) Maximum permitted weight (kg)
	a combination not described in item 5	

**Textual Amendments**

**F687** Words in Sch. 11 Pt. IV substituted (24.3.1994) by The Road Vehicles (Construction and Use) (Amendment) (No. 2) Regulations 1994 (S.I. 1994/329), regs. 1, 11(3)

**[F688] PART V Regulation 79(2)**

**VEHICLES WITH TWO CLOSELY-SPACED AXLES**

**Textual Amendments**

**F688** Sch. 11 Pt. 5 substituted (1.1.1993) by The Road Vehicles (Construction and Use) (Amendment) (No. 4) Regulations 1992 (S.I. 1992/2016), regs. 1, 10(d), Sch. 2 Pt. IV

(1) Item	(2) Description of vehicle	(3) Maximum permitted weight of the two closely spaced axles (kg)
1	A motor vehicle or trailer in which (in either case) the distance between the two closely-spaced axles is less than 1.3 metres	16,000
2	A vehicle being— (a) a motor vehicle in which the distance between the two closely-spaced axles is at least 1.3m, or (b) a trailer in which that distance is at least 1.3m and less than 1.5m, not being a vehicle described in item 3 or 4	18,000
3	A motor vehicle in which the distance between the two closely-spaced axles is at least 1.3m and— (a) every driving axle not being a steering axle is fitted with twin tyres; and (b) either every driving axle is fitted with road	19,000

**Status:** Point in time view as at 31/03/2009.

**Status:** This revised version has been created from an electronic version contributed by Westlaw which was originally derived from the printed publication. **Read more** (See end of Document for details)**Changes to legislation:** There are currently no known outstanding effects for the The Road Vehicles (Construction and Use) Regulations 1986. (See end of Document for details)

(1) Item	(2) Description of vehicle	(3) Maximum permitted weight of the two closely spaced axles (kg)
	friendly suspension or neither of the two closely-spaced axles has an axle weight exceeding 9,500 kg	
4	A trailer in which— (a) the two closely-spaced axles are driven from the motor vehicle drawing the trailer and are fitted with twin tyres; and (b) either those axles are fitted with road friendly suspension or neither of them has an axle weight exceeding 9,500 kg	19,000
5	A trailer in which the distance between the two closely-spaced axles is at least 1.5m and less than 1.8m	19,320
6	A trailer in which the distance between the two closely-spaced axles is at least 1.8m	20,000]

## [<sup>F689</sup>PART VI Regulation 79(3)

### VEHICLES WITH THREE CLOSELY-SPACED AXLES

#### Textual Amendments

**F689** Sch. 11 Pt. 6 substituted (1.1.1993) by The Road Vehicles (Construction and Use) (Amendment) (No. 4) Regulations 1992 (S.I. 1992/2016), regs. 1, 10(e), **Sch. 2 Pt. V**

(1) Item	(2) Description of vehicle	(3) Maximum permitted weight of the three closely-spaced axles (kg)
1	A vehicle in which the smallest distance between any two of the three closely-spaced axles is less than 1.3m	21,000
2	A vehicle in which the smallest distance between any two of the three closely-spaced axles	22,500

**Status:** Point in time view as at 31/03/2009.

**Status:** This revised version has been created from an electronic version contributed by Westlaw which was originally derived from the printed publication. **Read more** (See end of Document for details)**Changes to legislation:** There are currently no known outstanding effects for the The Road Vehicles (Construction and Use) Regulations 1986. (See end of Document for details)

(1) Item	(2) Description of vehicle	(3) Maximum permitted weight of the three closely-spaced axles (kg)
3	<p>is at least 1.3m and at least one of those axles does not have air suspension</p> <p>A vehicle in which the smallest distance between any two of the three closely-spaced axles is at least 1.3m and all three axles are fitted with air suspension</p>	24,000]

(see regulation 79(4))

## F<sup>690</sup>PART VII

### Maximum permitted weight of three adjacent axles

#### Textual Amendments

**F690** Sch. 11 Pt. 7 omitted (1.1.1993) by virtue of The Road Vehicles (Construction and Use) (Amendment) (No. 4) Regulations 1992 (S.I. 1992/2016), regs. 1, **10(f)**

F<sup>690</sup> ...

[<sup>F691</sup>SCHEDULE 11A  
(see regulations 76(1A),  
77(2A) and [<sup>F692</sup>80(2B)])]

### EXEMPTIONS RELATING TO COMBINED TRANSPORT OPERATIONS

#### Textual Amendments

**F691** Sch. 11A inserted (24.3.1994) by The Road Vehicles (Construction and Use) (Amendment) (No. 2) Regulations 1994 (S.I. 1994/329), regs. 1, 12, **Sch. 3**

**F692** Word in Sch. 11A heading substituted (22.4.1997) by The Road Vehicles (Construction and Use) (Amendment) (No. 2) Regulations 1997 (S.I. 1997/1096), regs. 1, **4(2)**

## PART I

### GENERAL

1. Regulation 76 does not apply to a wheeled heavy motor car drawing one wheeled trailer if the requirements set out in Part II of this Schedule are for the time being fulfilled.



2. Regulation 77 does not apply to an articulated vehicle if the requirements set out in Part III of this Schedule are for the time being fulfilled.

[  
F693 2A. Regulations 75, 76, 77 and 78 do not apply to an articulated vehicle if the requirements set out in Part IIIA of this Schedule are for the time being fulfilled.]

#### Textual Amendments

**F693** Sch. 11A para. 2A inserted (1.1.1999) by The Road Vehicles (Construction and Use) (Amendment) (No. 7) Regulations 1998 (S.I. 1998/3112), regs. 1, 11(2)

## PART II

### DRAWBAR COMBINATIONS

3.—(1) The drawing vehicle and trailer must each be carrying a relevant receptacle as part of a combined transport operation, each such receptacle being on a journey—

- (a) to a railhead from which the relevant receptacle is, as part of the operation, to be transported in a relevant manner by railway pursuant to a relevant contract made before the journey began; or
- (b) from a railhead to which the relevant receptacle has, as part of the operation, been transported in a relevant manner by railway.

(2) There must be carried in the cab of the drawing vehicle a document or documents—

- (a) if the vehicle is on a journey to a railhead, specifying the railhead, the date the relevant contract was made and the parties thereto;
- (b) if the vehicle is on a journey from a railhead, specifying the railhead and the date and time at which the receptacles were collected from that railhead.

4. The following conditions must be satisfied in relation to the drawing vehicle, namely—

- (a) it complies with the relevant braking requirement;
- (b) every driving axle not being a steering axle is fitted with twin tyres; and
- (c) either every driving axle is fitted with road friendly suspension or no axle has an axle weight exceeding 8,500kg.

5.—(1) The motor vehicle and trailer must have a total of at least 6 axles.

(2) The total laden weight of the motor vehicle and trailer must not exceed 44,000kg.

## PART III

### ARTICULATED VEHICLES

6.—(1) The motor vehicle comprised in the articulated vehicle must be being used for the conveyance of a loading unit as part of a combined transport operation, the loading unit being on a journey—

**Status:** Point in time view as at 31/03/2009.

**Status:** This revised version has been created from an electronic version contributed by Westlaw which was originally derived from the printed publication. **Read more** (See end of Document for details)**Changes to legislation:** There are currently no known outstanding effects for the The Road Vehicles (Construction and Use) Regulations 1998. (See end of Document for details)

- (a) to a railhead from which the loading unit is, as part of the operation, to be transported in a relevant manner by railway pursuant to a relevant contract made before the journey began; or
  - (b) from a railhead to which the loading unit has, as part of the operation, been transported in a relevant manner by railway.
- (2) If the loading unit is a bi-modal vehicle, the semi-trailer comprised in the articulated vehicle must be the bi-modal vehicle in its semi-trailer mode.
- (3) If the loading unit is a relevant receptacle, the relevant receptacle must be being carried on the semi-trailer comprised in the articulated vehicle.
- (4) There must be carried in the cab of the motor vehicle a document or documents—
- (a) if the vehicle is on a journey to a railhead, specifying the railhead, the date the contract was made and the parties thereto;
  - (b) if the vehicle is on a journey from a railhead, specifying the railhead and the date and time at which the loading unit was collected from that railhead.
7. The following conditions must be satisfied in relation to the motor vehicle, namely—
- (a) it complies with the relevant braking requirements;
  - (b) it has at least three axles;
  - (c) every driving axle not being a steering axle is fitted with twin tyres; and
  - (d) either every driving axle is fitted with road friendly suspension or no axle has an axle weight exceeding 8,500kg.

<sup>F694</sup>8.—(1) The articulated vehicle must have a total of at least 6 axles.

(2) The laden weight of the articulated vehicle must not exceed the weight determined in accordance with sub-paragraph (3).

(3) The weight for the purposes of sub-paragraph (2) is the number of kilograms equal to the product of the distance measured in metres between the king-pin and the centre of the rearmost axle of the semi-trailer multiplied by 5500 and rounded up to the nearest 10 kg, if that number is less than 44000 kg.]

#### Textual Amendments

**F694** Sch. 11A para. 8 substituted (1.1.1999) by [The Road Vehicles \(Construction and Use\) \(Amendment\) \(No. 7\) Regulations 1998 \(S.I. 1998/3112\)](#), regs. 1, **11(3)**

## <sup>F695</sup>PART IIIA

### ARTICULATED VEHICLES (ALTERNATIVE REQUIREMENTS)

#### Textual Amendments

**F695** Sch. 11A Pt. 3A inserted (1.1.1999) by [The Road Vehicles \(Construction and Use\) \(Amendment\) \(No. 7\) Regulations 1998 \(S.I. 1998/3112\)](#), regs. 1, **11(4)**

**8A.**—(1) The requirements of paragraph 6 are fulfilled.

(2) The vehicle is one which falls within the first indent of paragraph 1 of Article 3 of Community Directive 96/53 (vehicles used in international traffic or put into circulation in any other Member State) and complies with the limit values specified in paragraph 2.2.2 of Annex I and the other relevant requirements of that Directive.]

## PART IV INTERPRETATION

9.—(1) In this Schedule—

“bi-modal vehicle” means a semi-trailer which can be adapted for use as a railway vehicle;

“journey”, except in sub-paragraph (3), means a journey by road;

“loading unit” means a bi-modal vehicle [<sup>F696</sup>, road-rail semi-trailer] or a relevant receptacle;

“railhead” means a facility for the transhipment of—

- (a) bi-modal vehicles from the ground onto the track of a railway, or
- (b) relevant receptacles from road vehicles onto railway vehicles situated on the track of a railway, [<sup>F697</sup> or,
- (c) road-rail semi-trailers from the ground onto railway vehicles on the track of a railway,] or vice versa;

“relevant contract” means a contract for the transport of a loading unit by railway;

“relevant receptacle” means a receptacle (not being a vehicle) having a length of at least 6.1m designed and constructed for repeated use for the carriage of goods on, and for transfer between, road vehicles and railway vehicles;

[<sup>F698</sup>“road-rail semi-trailer” means a semi-trailer constructed or adapted so as to be capable of being both used as a semi-trailer on roads and carried on a railway vehicle;]

“road friendly suspension” and “twin tyres” have the meanings given by regulation 75; and

“network”, “network licence”, “railway vehicle”, “track” and “train” have the meanings given by section 83 of the Railways Act 1993.

(2) The definition of “railway” in section 67(1) of the Transport and Works Act 1992 shall have effect for the purposes of this Schedule as it has effect for the purposes of that Act, and cognate expressions shall be construed accordingly.

(3) In these Regulations, a reference to a combined transport operation is a reference to the transport of a loading unit on a journey where—

- (a) part of the journey is by railway on a network operated by the British Railways Board or under a network licence;
- (b) part of the journey is by road; and
- (c) no goods are added to or removed from the loading unit between the time when the journey begins and the time when it ends.

(4) Subject to sub-paragraph (5), for the purposes of this Schedule—

- (a) a bi-modal vehicle shall be regarded as being transported by railway in a relevant manner if and only if the vehicle in its railway vehicle mode is travelling by railway as part of a train; <sup>F699</sup> ...
- (b) a relevant receptacle shall be regarded as being transported by railway in a relevant manner if and only if it is being carried on a railway vehicle which forms part of a train, [<sup>F700</sup> and

**Status:** Point in time view as at 31/03/2009.

**Status:** This revised version has been created from an electronic version contributed by Westlaw which was originally derived from the printed publication. **Read more** (See end of Document for details)**Changes to legislation:** There are currently no known outstanding effects for the The Road Vehicles (Construction and Use) Regulations 1986. (See end of Document for details)

- (c) a road-rail semi-trailer shall be regarded as being transported by railway in a relevant manner if and only if it is being carried on a railway vehicle which forms part of a train.]
- (5) A relevant receptacle shall be regarded, for the purposes of this Schedule, as not being transported by railway in a relevant manner at any time when—
- (a) the relevant receptacle is in or on a motor vehicle or trailer; and
  - (b) the motor vehicle or trailer is being carried on a railway vehicle.

[<sup>F701</sup>(6) A road-rail semi-trailer shall be regarded, for the purposes of this Schedule, as not being transported by railway in a relevant manner at any time when it is being carried on a railway vehicle as part of an articulated vehicle.]]

#### Textual Amendments

- F696** Words in Sch. 11A para. 9(1) inserted (22.4.1997) by The Road Vehicles (Construction and Use) (Amendment) (No. 2) Regulations 1997 (S.I. 1997/1096), regs. 1, 4(3)(a)
- F697** Words in Sch. 11A para. 9(1) inserted (22.4.1997) by The Road Vehicles (Construction and Use) (Amendment) (No. 2) Regulations 1997 (S.I. 1997/1096), regs. 1, 4(3)(b)
- F698** Words in Sch. 11A para. 9(1) inserted (22.4.1997) by The Road Vehicles (Construction and Use) (Amendment) (No. 2) Regulations 1997 (S.I. 1997/1096), regs. 1, 4(3)(c)
- F699** Word in Sch. 11A para. 9(4) omitted (22.4.1997) by virtue of The Road Vehicles (Construction and Use) (Amendment) (No. 2) Regulations 1997 (S.I. 1997/1096), regs. 1, 4(5)(a)
- F700** Sch. 11A para. 9(4)(c) and word inserted (22.4.1997) by The Road Vehicles (Construction and Use) (Amendment) (No. 2) Regulations 1997 (S.I. 1997/1096), regs. 1, 4(5)(b)
- F701** Sch. 11A para. 9(6) inserted (22.4.1997) by The Road Vehicles (Construction and Use) (Amendment) (No. 2) Regulations 1997 (S.I. 1997/1096), regs. 1, 4(6)

## SCHEDULE 12

(see regulations 81 and 82)

CONDITIONS TO BE COMPLIED WITH IN RELATION TO THE USE OF  
VEHICLES CARRYING WIDE OR LONG LOADS OR VEHICLES CARRYING  
LOADS OR HAVING FIXED APPLIANCES OR APPARATUS WHICH PROJECT

## PART I

### Advance notice to Police

- (a) (a) Before using on a road a vehicle or vehicles to which this paragraph applies, the owner shall give notice of the intended use to the Chief Officer of Police for any area in which he proposes to use the vehicle or vehicles. The notice shall be given so that it is received by the date after which there are at least two working days before the date on which the use of the vehicle or vehicles is to begin, and shall include the following details—
- (i) time, date and route of the proposed journey, and
- [<sup>F702</sup>(ia) in a case to which regulation 7(9) applies, the overall length of the trailer,]

**Status:** Point in time view as at 31/03/2009.

**Status:** This revised version has been created from an electronic version contributed by Westlaw which was originally derived from the printed publication. **Read more** (See end of Document for details)**Changes to legislation:** There are currently no known outstanding effects for the The Road Vehicles (Construction and Use) Regulations 1986. (See end of Document for details)

- (ii) in a case to which regulation 82(2) applies, the overall length and width of the vehicle by which the load is carried and the width of the lateral projection or projections of its load,
- (iii) in a case to which regulation 82(4)(a) applies, the overall length and width of each vehicle by which the load is carried, the length of any forward or rearward projection and, where the load rests on more than one vehicle, the distance between the vehicles,
- (iv) in a case to which regulation 82(4)(b) applies, the overall length of the combination of vehicles and the length of any forward or rearward projection of the load, and
- (v) in a case to which regulation 82(7) and (8) applies, the overall length of the vehicle and the length of any forward or rearward projection of the load or special appliance or apparatus.

The Chief Officer of Police for any police area may, at his discretion, accept a shorter period of notice or fewer details.

- (b) The vehicle or vehicles shall be used only in accordance with the details at (a) subject to any variation in the time, date or route which may be directed by—
  - (i) any such Chief Officer of Police to the owner of the vehicle or vehicles, or
  - (ii) a police constable to the driver in the interests of road safety or in order to avoid undue traffic congestion by halting the vehicle or vehicles in a place on or adjacent to the road on which the vehicle or vehicles are travelling.
- (c) In this paragraph—
  - (i) “Chief Officer of Police” has, in relation to England and Wales, the same meaning as in the Police Act 1964, and in relation to Scotland, the same meaning as in the Police (Scotland) Act 1967,
  - (ii) “working day” means a day which is not a Sunday, a bank holiday, Christmas Day or Good Friday, and
  - (iii) “bank holiday” means a day which is a bank holiday by or under the Banking and Financial Dealings Act 1971, either generally or in the locality in which the road is situated.

#### Textual Amendments

**F702** Sch. 12 para. 1(a)(ia) inserted (17.10.1991) by [The Road Vehicles \(Construction and Use\) \(Amendment\) \(No. 4\) Regulations 1991 \(S.I. 1991/2125\)](#), regs. 1, 6

#### Commencement Information

**I170** Sch. 12 para. 1 in force at 11.8.1986, see [reg. 1](#)

### Attendants

2. At least one person in addition to the person or persons employed in driving a motor vehicle to which this paragraph applies shall be employed—

- (a) in attending to that vehicle and its load and any other vehicle or vehicles drawn by that vehicle and the load or loads carried on the vehicle or vehicles so drawn, and
- (b) to give warning to the driver of the said motor vehicle and to any person of any danger likely to be caused to any such other person by reason of the presence of the said vehicle or vehicles on the road.

**Status:** Point in time view as at 31/03/2009.

**Status:** This revised version has been created from an electronic version contributed by Westlaw which was originally derived from the printed publication. **Read more** (See end of Document for details)**Changes to legislation:** There are currently no known outstanding effects for the The Road Vehicles (Construction and Use) Regulations 1986. (See end of Document for details)

Provided that, where three or more vehicles as respects which the conditions in this paragraph are applicable are travelling together in convoy, it shall be a sufficient compliance with this paragraph if only the foremost and rearmost vehicles in the convoy are attended in the manner prescribed in this paragraph.

For the purpose of this paragraph when a motor vehicle is drawing a trailer or trailers—

- (i) any person employed in pursuance of section 34 of the 1972 Act in attending that vehicle or any such trailer shall be treated as being an attendant required by this paragraph so long as he is also employed to discharge the duties mentioned in this paragraph; and
- (ii) when another motor vehicle is used for the purpose of assisting in their propulsion on the road, the person or persons employed in driving that other motor vehicle shall not be treated as a person or persons employed in attending to the first-mentioned vehicle or any vehicle or vehicles drawn thereby.

#### Commencement Information

**I171** Sch. 12 para. 2 in force at 11.8.1986, see [reg. 1](#)

#### Marking of longer projections

- (a) (a) Every forward and rearward projection to which this paragraph applies shall be fitted with—
  - (i) an end marker, except in the case of a rearward projection which is fitted with a rear marking in accordance with the Lighting Regulations, and
  - (ii) where required by sub-paragraphs (c) and (d) of this paragraph, two or more side markers;
 which shall be of the size, shape and colour described in Part II of this Schedule.
- (b) the end marker shall be so fitted that—
  - (i) it is as near as is practicable in a transverse plane,
  - (ii) it is not more than 0.5 m from the extreme end of the projection,
  - (iii) the vertical distance between the lowest point of the marker and the road surface is not more than 2.5 m,
  - (iv) it, and any means by which it is fitted to the projection, impedes the view of the driver as little as possible, and
  - (v) it is clearly visible within a reasonable distance to a person using the road at the end of the vehicle from which the projection extends;
- (c) where the forward projection exceeds 2 m or the rearward projection exceeds 3 m, one side marker shall be fitted on the right hand side and one on the left hand side of the projection so that—
  - (i) each marker is as near as is practicable in a longitudinal plane,
  - (ii) no part extends beyond the end of the projection,
  - (iii) the vertical distance between the lowest part of each marker and the surface of the road is not more than 2.5 m,
  - (iv) the horizontal distance between each marker and the end marker or, as the case may be, the rear marking carried in accordance with the Lighting Regulations does not exceed 1 m, and

**Status:** Point in time view as at 31/03/2009.

**Status:** This revised version has been created from an electronic version contributed by Westlaw which was originally derived from the printed publication. **Read more** (See end of Document for details)**Changes to legislation:** There are currently no known outstanding effects for the The Road Vehicles (Construction and Use) Regulations 1986. (See end of Document for details)

- (v) each marker is clearly visible within a reasonable distance to a person using the road on that side of the projection;
- (d) where—
  - (i) a forward projection exceeds 4.5 m, or
  - (ii) a rearward projection exceeds 5 mextra side markers shall be fitted on either side of the projection so that the horizontal distance between the extreme projecting point of the vehicle from which the projection extends and the nearest point on any side marker from that point, and between the nearest points of any adjacent side markers on the same side does not exceed—
  - 2.5 m in the case of a forward projection, or
  - 3.5 m in the case of a rearward projection.For the purposes of this sub-paragraph the expression “the vehicle” shall not include any special appliance or apparatus or any part thereof which is a forward projection or a rearward projection within the meaning of regulation 81;
- (e) the extra side markers required by this sub-paragraph shall also meet the requirements of (i), (iii) and (v) of sub-paragraph (c);
- (f) every marker fitted in accordance with this paragraph shall be kept clean and unobscured and [<sup>F703</sup>between sunset and sunrise] be illuminated by a lamp which renders it readily visible from a reasonable distance and which is so shielded that its light, except as reflected from the marker, is not visible to other persons using the road.

#### Textual Amendments

**F703** Words in [Sch. 12 para. 3\(f\)](#) substituted (17.10.1991) by [The Road Vehicles \(Construction and Use\) \(Amendment\) \(No. 4\) Regulations 1991 \(S.I. 1991/2125\)](#), regs. 1, **9(2)**

#### Commencement Information

**I172** [Sch. 12 para. 3](#) in force at 11.8.1986, see [reg. 1](#)

### Marking of shorter projections

4. A projection to which this paragraph applies shall be rendered clearly visible to other persons using the road within a reasonable distance, in the case of a forward projection, from the front thereof or, in the case of a rearward projection, from the rear thereof and, in either case, from either side thereof.

#### Commencement Information

**I173** [Sch. 12 para. 4](#) in force at 11.8.1986, see [reg. 1](#)

### [<sup>F704</sup>Marking of wide loads

5

- (a) Subject to sub-paragraph (d), every load carried on a vehicle in circumstances where this paragraph applies shall be fitted on each side and in the prescribed manner, with—
  - (i) a prescribed marker in such a position that it is visible from the front of the vehicle, and

**Status:** Point in time view as at 31/03/2009.

**Status:** This revised version has been created from an electronic version contributed by Westlaw which was originally derived from the printed publication. **Read more** (See end of Document for details)**Changes to legislation:** There are currently no known outstanding effects for the The Road Vehicles (Construction and Use) Regulations 1986. (See end of Document for details)

- (ii) a prescribed marker in such a position that it is visible from the rear of the vehicle,
- (b) For the purposes of sub-paragraph (a)—
  - (i) a marker on a side of the load is fitted in the prescribed manner if at least part of it is within 50mm of a longitudinal plane passing through the point on that side of the load which is furthest from the axis of the vehicle; and
  - (ii) a prescribed marker is a marker of the size, shape and colour described in Part II of this Schedule.
- (c) Every marker fitted pursuant to this paragraph shall be kept clean and between sunset and sunrise be illuminated by a lamp which renders it readily visible from a reasonable distance and which is so shielded that its light, except as reflected from the marker, is not visible to other persons using the road.
- (d) If the load does not extend beyond the longitudinal plane passing through the extreme projecting point on one side of the vehicle, it shall not be necessary for a marker to be fitted to the load on that side.]

**Textual Amendments**

**F704** Sch. 12 para. 5 inserted (17.10.1991) by [The Road Vehicles \(Construction and Use\) \(Amendment\) \(No. 4\) Regulations 1991 \(S.I. 1991/2125\)](#), regs. 1, **9(1)**

[<sup>F705</sup>(see paragraph 3(a) and 5(b) of this Schedule)]

**PART II**

**PROJECTION MARKERS<sup>F705</sup>**

**Textual Amendments**

**F705** Sch. 12 Pt. 2 shoulder note substituted (17.10.1991) by [The Road Vehicles \(Construction and Use\) \(Amendment\) \(No. 4\) Regulations 1991 \(S.I. 1991/2125\)](#), regs. 1, **9(3)**

**Commencement Information**

**I174** Sch. 12 Pt. 2I in force at 11.8.1986, see [reg. 1](#)

DIAGRAM OF END MARKER SURFACE

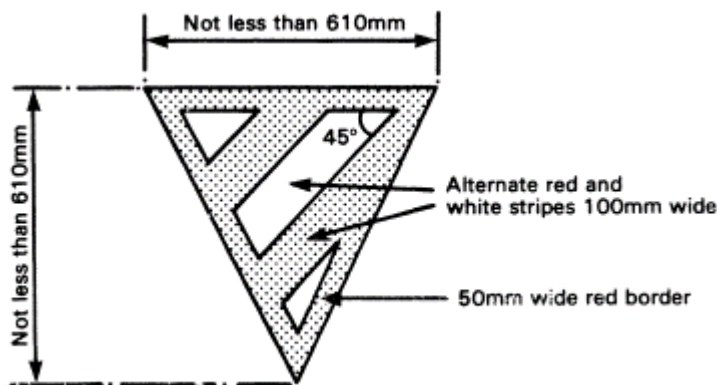



## DIAGRAM OF SIDE MARKER SURFACE

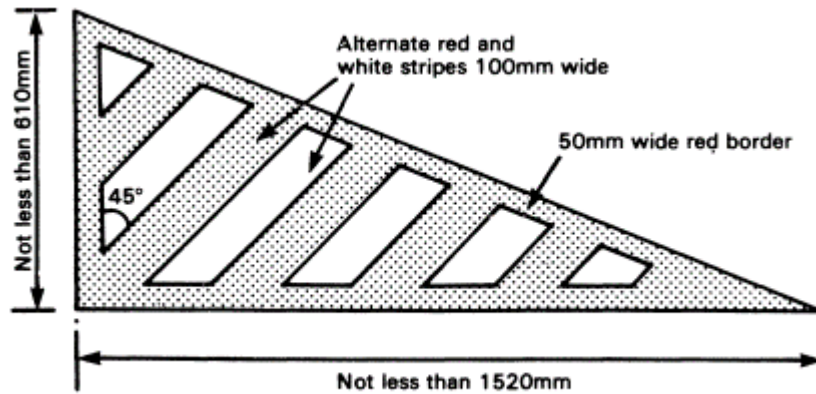

[<sup>F706</sup>SCHEDULE 13

(see regulation 3(2))

## PLATE FOR RESTRICTED SPEED VEHICLE

### Textual Amendments

**F706** Sch. 13 inserted (2.11.1990) by [The Road Vehicles \(Construction and Use\) \(Amendment\) \(No. 4\) Regulations 1990 \(S.I. 1990/1981\)](#), reg. 1, **Sch.**

1. A vehicle displays a plate in accordance with the requirements of this Schedule if a plate in respect of which the following conditions are satisfied is displayed on the vehicle in a prominent position.

(2) The conditions are—

- (a) the plate must be in the form shown in the diagram below;
- (b) the plate must be at least 150mm wide and at least 120mm high;
- (c) the figures “5” and “0” must be at least 100mm high and 50mm wide with a stroke width of at least 12mm, the figures being black on a white background; and
- (d) the border must be black and between 3mm and 5mm wide.]

**Status:** Point in time view as at 31/03/2009.

**Status:** This revised version has been created from an electronic version contributed by Westlaw which was originally derived from the printed publication. **Read more** (See end of Document for details)**Changes to legislation:** There are currently no known outstanding effects for the The Road Vehicles (Construction and Use) Regulations 1986. (See end of Document for details)



---

## EXPLANATORY NOTE

1. These Regulations consolidate (with amendments) the Motor Vehicles (Construction and Use) Regulations 1978 as amended and the Motor Vehicles (Construction and Use) (Track Laying Vehicles) Regulations 1955 as amended. The Statutory Instruments specified in Schedule 1 are revoked and re-enacted in a new presentation with more extensive use of tabulations, more logical arrangement of material and, as far as possible, simplified language.

### Substantive changes in the requirements

2. The principal new requirements (including withdrawals of exemptions) are listed and explained in sub-paragraphs (i) to (xxvi) below—

- (i) regulation 7 to conform to the requirements of EC Directive 85/3, vehicles normally used on international journeys are exempted from the semi-trailer length limit of 12.2 metres;
- (ii) regulation 8 an increase in the maximum permitted width of refrigerated lorries is incorporated in recognition of the need for good thermal efficiency;
- (iii) regulation 9 the height limit in paragraph (1), applicable to public service vehicles whenever first used and to large passenger-carrying vehicles first used on or after

**Status:** This revised version has been created from an electronic version contributed by Westlaw which was originally derived from the printed publication. **Read more** (See end of Document for details)**Changes to legislation:** There are currently no known outstanding effects for the The Road Vehicles (Construction and Use) Regulations 1986. (See end of Document for details)

- 1st April 1982, is extended to all buses (the term “bus” replaces “large passenger-carrying vehicle”);
- (iv) regulation 10 the requirement for height notices in cabs, since it is easily complied with and does not require modification of the vehicle, is extended to track-laying vehicles;
  - (v) regulation 13 the exclusions for buses first used before 1 April 1982, for minibuses and for vehicles not exceeding 7m in length are omitted;
  - (vi) regulation 18(4)(b) the interpretation of the requirements as to braking efficiency in the sense that they must be met by a goods vehicle when operated at its maximum design weight, which was explicit in the case of plated vehicles, is also made explicit in relation to goods vehicles which are not plated;
  - (vii) regulations 24 and 26 the use of temporary use spare tyres on passenger cars is permitted in certain circumstances;
  - (viii) regulation 26 goods vehicles and buses are required to be fitted with tyres designed and maintained to support the vehicle's maximum axle weights at the vehicle's maximum permitted speed;
  - (ix) regulation 28 the separate provision for agricultural motor vehicles first used before 1st January 1936 is omitted, as being out of date;
  - (x) regulation 32(6) this provision, previously proposed for minibuses, is extended to all buses;
  - (xi) regulation 32(9) the special provision in relation to French approved glass is limited to vehicles first used before 1 October 1986;
  - (xii) regulation 33 new provisions recognising the requirements of EC Directive 85/205 for heavy goods vehicles are introduced;
  - (xiii) regulations 40 and 94-96 in the interests of safety the requirements of Schedule 5 as to gas systems are extended to track-laying vehicles. The necessary statement by the Secretary of State is included in regulation 4(4);
  - (xiv) regulations 41-44 and Schedules 6 and 7 new construction requirements are introduced for vehicles with between 9 and 16 passenger seats first used on or after 1st April 1988;
  - (xv) regulation 54 the inadvertent effect of amendments to the revoked Regulations was that vehicles first used before 1st April 1970 were not subject to any requirement not to make alterations resulting in increased noise. In view of this the earlier provision (which continued to apply to track-laying vehicles) is restored;
  - (xvi) regulations 55 and 56 an error in S.I. 1984/1809, under which agricultural motor vehicles first used on or after 1st June 1986 and driven at more than 20 mph were excluded from certain noise requirements, but not included in others, is corrected, and new provisions concerning noise limits are introduced to comply with the requirements of EC Directive 84/424, and to set new limits for some vehicles outside the scope of the Directive;
  - (xvii) regulation 63 the exemption for trailer pumps used for fire brigade purposes has been omitted;
  - (xviii) regulation 67 the option for vehicles fitted with plates complying with Directive 76/114 is limited to vehicles first used before 1 April 1987; vehicles first used on or after that date are required to comply with Directive 78/507;

**Status:** Point in time view as at 31/03/2009.

**Status:** This revised version has been created from an electronic version contributed by Westlaw which was originally derived from the printed publication. **Read more** (See end of Document for details) **Changes to legislation:** There are currently no known outstanding effects for the The Road Vehicles (Construction and Use) Regulations 1986. (See end of Document for details)

- (xix) regulation 75 Table, sub3s 13 to 15, regulation 76 Table, sub3 4, and regulation 78 Table, sub3 11 special provisions, in the case of track-laying vehicles, for winding gear and for gas equipment, are omitted as being out of date;
- (xx) regulation 79 and Schedule 11 to conform to the requirements of EC Directive 85/3 triaxle spacing for a 22.5 tonnes load is reduced from 1.35 metres to 1.30 metres;
- (xxi) regulation 82 the previous dimensions of 1.07 and 1.83 metres are for convenience rounded to 1 and 2 metres. The treatment of track-laying vehicles is brought into line with that of wheeled vehicles;
- (xxii) regulation 83 the provision under which water-carrying trailers were disregarded has been omitted, as out of date;
- (xxiii) regulation 105 is extended to track-laying vehicles;
- (xxiv) regulation 107 the exclusion for gas-propelled vehicles is omitted, as being out of date;
- (xxv) regulation 108 the provision concerning suspension of implements is extended to track-laying vehicles;
- (xxvi) regulation 109 revised provisions governing the use of television sets in motor vehicles in use on the road are introduced.

**3.** Recognition of compliance with European vehicle standards as an alternative to national standards has been made more comprehensive by the insertion of appropriate references in Part II, which are interpreted in accordance with regulations 3 and 6. This system supersedes the provisions of former regulations 5, 5A, 5AA and 5B. In the former regulations the fact that a vehicle had been marked or certificated when new to show that it complied with a European standard for a particular system or component meant that it was totally exempted from the substantive regulation dealing with that system or component. Now, in the case of regulations dealing with systems or components which are liable to deteriorate or be replaced while the vehicle is in use, only continued compliance with the European standard is accepted as an alternative to compliance with the national standard.

**4.** In regulation 7 the maximum permitted length of motor vehicles having at least 4 wheels is increased from 11m to 12m in accordance with Community Directive 85/3, and, in consequence, the previous turning circle requirements for articulated buses are dropped.

**5.** References to public service vehicles are replaced by references to buses.

**6.** Other relaxations in the 1978 and 1955 (TLV) Regulations are referred to in the Table of Derivations at Annex A following; regulations which have been omitted entirely are listed, with appropriate explanations, in sub-paragraphs (i) to (xi) below—

- (i) regulations 5-5B see above (para 3);
- (ii) regulation 6 no longer necessary as relevant provisions appear in individual regulations;
- (iii) regulations 15 and 16 the coverage of these regulations is generally confined to vehicles subject to National Type Approval, and the systems concerned are not likely to be modified or to deteriorate;
- (iv) regulations 21 and 40 and TLV regulation 13 no longer considered necessary;
- (v) regulation 99 this maintenance requirement for power-weight ratio is implicit in the corresponding construction requirement, in that some maintenance is necessary to ensure continued compliance;
- (vi) regulation 114 and TLV regulation 59 it is doubted whether the proviso to these regulations was *intra vires*; new regulation 97 is considered sufficient;

**Status:** Point in time view as at 31/03/2009.

**Status:** This revised version has been created from an electronic version contributed by Westlaw which was originally derived from the printed publication. **Read more** (See end of Document for details)**Changes to legislation:** There are currently no known outstanding effects for the The Road Vehicles (Construction and Use) Regulations 1986. (See end of Document for details)

- (vii) regulation 116 the in-use noise limits were not, in practice, enforceable and have therefore been omitted;
- (viii) regulation 116B as the construction requirements referred to apply throughout the life of the vehicle on the road and cannot be complied with unless the parts necessary to comply with it are fitted, this regulation is considered to be superfluous;
- (ix) regulation 121 (TLV66) no longer considered necessary;
- (x) regulations 146 and 147 these are dropped as Part V is not retained as a separate Part. Where necessary definitions are transferred to regulation 3;
- (xi) TLV regulation 77 this is no longer appropriate to the Regulations.

7. Changes which do not affect the substance of the requirements are very numerous, but are not listed separately.

8. Annex B lists these regulations and shows where their content was to be found in the revoked Regulations.

## ANNEX A

### DERIVATION OF REGULATIONS AND SCHEDULES

<i>NEW REGULATION NO</i>	<i>OLD REGULATION NO</i>		<i>SUBJECT MATTER AND DESCRIPTION OF SUBSTANTIVE CHANGES(changes mentioned in paragraphs 2–5 above are not repeated in this Annex)</i>
	<i>C&amp;U</i>	<i>TLV</i>	
1	1	1	<i>Commencement and citation</i>
2	2	2	<i>Revocations</i>
3	3	3	<i>Interpretation</i>
			Paragraph (1) provides for a simplified system of cross-references within the Regulations and Schedules.
			paragraph (2) introduces the following changes in the set of definitions contained in old regulation 3(2) as amended—
			The following definitions are omitted—
			“the 1960 Act”
			“the 1967 Act”
			“direction indicator”
			“half-decked vehicle”
			“H.P. Din”
			“hours of darkness” (the effect of this is now contained in regulation 97(1))
			“large passenger-carrying vehicle” (now appears under “bus”)
			“liquified petroleum gas” (transferred to regulation 94)
			“multi-pull means of operation” (transferred to Schedule 3)
			“safety glass” (transferred to regulation 30(4))

**Status:** Point in time view as at 31/03/2009.

**Status:** This revised version has been created from an electronic version contributed by Westlaw which was originally derived from the printed publication. **Read more** (See end of Document for details)**Changes to legislation:** There are currently no known outstanding effects for the The Road Vehicles (Construction and Use) Regulations 1986. (See end of Document for details)

<i>NEW REGULATION NO</i>	<i>OLD REGULATION NO</i>	<i>C&amp;U</i>	<i>TLV</i>	<i>SUBJECT MATTER AND DESCRIPTION OF SUBSTANTIVE CHANGES(changes mentioned in paragraphs 2–5 above are not repeated in this Annex)</i>
				<p>“two-tone horn” (transferred to regulation 37(10))” (transferred to regulation 37(10))</p> <p>The following definitions are introduced—</p> <p>“The 1981 Act”</p> <p>“The 1984 Act”</p> <p>“The Type Approval for Goods Vehicles Regulations”</p> <p>“axle weight” (previously in regulation 146)</p> <p>“bus”</p> <p>“Community Directive”</p> <p>“container” (previously in regulation 80A)</p> <p>“design weight” (previously in regulation 146)</p> <p>“ECE Regulation”</p> <p>“engine power in kilowatts (kW) (replacing H.P. Din)</p> <p>“exhaust system” (previously defined, for a motorcycle in regulation 116C)</p> <p>“gross weight” (previously in regulation 146)</p> <p>“kerbside weight” (previously in regulation 136A)</p> <p>“longitudinal plane”</p> <p>“minibus”</p> <p>“maximum gross weight” (previously defined in various ways and also appearing without definition)</p> <p>“motor ambulance” (previously in regulations 17 and 26 in slightly different form)</p> <p>“overall height” (previously in regulation 10)</p> <p>“refuse vehicle”</p> <p>“relevant braking requirement”</p> <p>“resilient tyre”</p> <p>“secondary braking system”</p> <p>“service braking system”</p> <p>“silencer” (based upon revoked regulation 30)</p> <p>“temporary use spare tyre”</p> <p>“three-wheeled motor cycle”</p> <p>“transverse plane”</p> <p>“unbraked trailer” (previously in regulation 46A)” (previously in regulation 46A)</p> <p>The following definitions which repeat or are based on definitions appearing in sections 190 and 196 of the Road Traffic Act 1972 are included—</p> <p>“goods vehicle” (incorporating the definition in section 196 of “carriage”)</p> <p>“heavy motor car” (with modification to indicate that for the purposes of these Regulations locomotives and motor tractors are excluded)</p>

**Status:** Point in time view as at 31/03/2009.

**Status:** This revised version has been created from an electronic version contributed by Westlaw which was originally derived from the printed publication. **Read more** (See end of Document for details)**Changes to legislation:** There are currently no known outstanding effects for the The Road Vehicles (Construction and Use) Regulations 1986. (See end of Document for details)

<i>NEW REGULATION NO</i>	<i>OLD REGULATION NO</i>	<i>C&amp;U</i>	<i>TLV</i>	<i>SUBJECT MATTER AND DESCRIPTION OF SUBSTANTIVE CHANGES(changes mentioned in paragraphs 2–5 above are not repeated in this Annex)</i>
				<p>“invalid carriage”</p> <p>“locomotive” (incorporating the definitions in section 190 of “light locomotive” and “heavy locomotive”)</p> <p>“motor car” (with a modification to indicate that for the purpose of these Regulations motor tractors are excluded)</p> <p>“motor cycle”</p> <p>“motor vehicle”</p> <p>“trolley bus”</p> <p>“unladen weight”</p> <p>The following amended definitions are introduced—</p> <p>“The Approval Marks Regulations“ (replacing the previous definition of “The Designation of Approval Marks Regulations“)</p> <p>“ The Plating and Testing Regulations”</p> <p>“The Type Approval (Great Britain) Regulations”</p> <p>“agricultural trailed appliance” (inclusion of horticultural and forestry implements in (b)(ii))</p> <p>“overall length”</p> <p>“overall width”</p> <p>(the last two are based on the previous definitions as amended by S.I.1985/1363 but a number of out of date items of equipment are omitted and a simpler presentation is adopted).</p> <p>“recut pneumatic tyre”</p> <p>References are included in the list in respect of the following in order to draw attention to provisions appearing in subsequent paragraphs of the regulation—</p> <p>“axle”</p> <p>“axle weight”</p> <p>“braking system”</p> <p>“closely spaced”</p> <p>“first used”</p> <p>“resilient tyre”</p> <p>“trailer”</p> <p>“wheel”</p> <p>Regulation 3(6) (previously 3(4)) has been extended to apply also to brake discs.</p> <p>Regulations 3(7) and (8) (previously 3(5) and (6)) have been modified so as to exclude regulation 27 as well as regulation 26.</p>

**Status:** Point in time view as at 31/03/2009.

**Status:** This revised version has been created from an electronic version contributed by Westlaw which was originally derived from the printed publication. **Read more** (See end of Document for details)**Changes to legislation:** There are currently no known outstanding effects for the The Road Vehicles (Construction and Use) Regulations 1986. (See end of Document for details)

NEW REGULATION NO	OLD REGULATION NO		SUBJECT MATTER AND DESCRIPTION OF SUBSTANTIVE CHANGES(changes mentioned in paragraphs 2–5 above are not repeated in this Annex)
	C&U	TLV	
4	4	4	<p>Previous regulations 3(10) and (11) are no longer required as their effect is secured by the provisions of the Interpretation Act.</p> <p><i>Application and Exemptions</i></p> <p>Paragraph (1) embraces the scope of the previous Construction and Use Regulations and Track Laying Vehicles Regulations.</p> <p>Paragraphs 2 and 3 introduce new provisions making it unnecessary to define classes of motor vehicles by date of manufacture as well as by date of first use. Such definitions in the revoked Regulations appear in these Regulations as definitions referring solely to date of first use, the effect of the revoked references to date of manufacture being preserved by the new provisions.</p> <p><i>The Table</i> reproduces the effect of previous regulations 4(2) to (13) except as follows—</p> <p>Previous paragraphs (2) and (4) have been embodied in the regulations concerned;</p> <p>Previous paragraph (5) is omitted because the scope of the Regulations generally is use of vehicles on roads and the concept of limiting certain regulations to highways and thus theoretically exempting from them vehicles used only on roads which are not highways is considered to be of no practical significance;</p> <p>Previous paragraph (6) is no longer required (but see paragraph 2(viii) above).</p> <p>The exemption for having implements in item 7 of the Table (previous regulation 4(12)) is extended to cover previous regulations 80A and 95A. Previous paragraph (13) is considered to be implicit in any reference to the drawing of a breakdown vehicle and is therefore omitted.</p>
5	7	—	<p><i>Provisions as respects Trade Descriptions Act 1968</i></p> <p>A reference to treating marks as evidence of compliance with a standard is added, in consequence of regulation 6. This provision is extended to track-laying vehicles.</p>
6	—	—	<p><i>Compliance with Community Directives and ECE Regulations</i></p> <p>This Regulation explains what constitutes compliance with an EC Directive or an ECE Regulation.</p>



**Status:** This revised version has been created from an electronic version contributed by Westlaw which was originally derived from the printed publication. **Read more** (See end of Document for details) **Changes to legislation:** There are currently no known outstanding effects for the The Road Vehicles (Construction and Use) Regulations 1986. (See end of Document for details)

NEW REGULATION NO	OLD REGULATION NO		SUBJECT MATTER AND DESCRIPTION OF SUBSTANTIVE CHANGES (changes mentioned in paragraphs 2–5 above are not repeated in this Annex)
	C&U	TLV	
7	9	5, 34	<i>Length</i>  The following changes are embodied— (a) items 1 and 6 in the Table, and paragraphs (4) and (5) are applied to track-laying vehicles; (b) item 8(a) in the Table is based on maximum gross weight instead of unladen weight and the conditions are otherwise simplified; (c) item 8(b) increases the limit for agricultural trailers to 12m; (d) the exemption for trolley vehicles in the course of construction or delivery is omitted.
8	48, 53, 57, 62, 70, 74, 79A, 80 (part)	25, 30, 35	<i>Width</i> The previous width limits for wheeled vehicles are extended to track-laying vehicles in place of the lower limits for the latter, and the special lower limit for invalid carriages is omitted. The detailed provisions of previous regulations 74(1)(b) and (c) exempting certain trailers manufactured before 1st January 1933 are omitted, as is the exemption for trolley vehicles in the course of construction or delivery; Item 3 in the Table is based on maximum gross weight instead of unladen weight and the conditions are otherwise simplified. Item 4 extends the width limit for agricultural trailers to 2.5m.
9	10, 95A	—	<i>Height</i>
10	80A	—	<i>Indication of overall travelling height</i>
11	54, 58, 63, 79B	—	<i>Overhang</i> The exemption for heavy motor cars first used before 15.8.1928 is extended to those first used before 2.1.1933, in line with the exemption for motor cars.  The exemption for articulated buses is extended to cover all buses.
12	74A	—	<i>Minimum ground clearance</i>
13	9A	—	<i>Turning circle</i> The previous reference to compliance with provisions of ECE Regulation 36 is replaced by new paragraphs (2) to (5) which state directly the effect of those provisions.
14	9B	—	<i>Connecting sections and direction-holding of articulated buses</i>
15	14A	—	<i>Braking systems of certain vehicles first used on or after 1 April 1983</i>  ECE Regulation 13.05 is recognised as an additional option.

**Status:** Point in time view as at 31/03/2009.

**Status:** This revised version has been created from an electronic version contributed by Westlaw which was originally derived from the printed publication. **Read more** (See end of Document for details)**Changes to legislation:** There are currently no known outstanding effects for the The Road Vehicles (Construction and Use) Regulations 1986. (See end of Document for details)

NEW REGULATION NO	OLD REGULATION NO		SUBJECT MATTER AND DESCRIPTION OF SUBSTANTIVE CHANGES(changes mentioned in paragraphs 2–5 above are not repeated in this Annex)
	C&U	TLV	
16 with Schedule 3	13, 50, 51, 55, 59, 64, 67, 71, 75, 76, 79C & Sch 4A except as shown against Reg. 17	8, 28, 29, 30	An exemption is added for broken down vehicles being drawn in consequence of the breakdown.  <i>Braking systems of vehicle to which regulation 15 does not apply</i>  The previous provisions are substantially simplified, notably by— (a) the omission of the requirement to have two means of operation; (b) the omission of the requirements in previous regulations 51(6), 55(5), 59(13) and 64(13); (c) the replacement of provisions relating to determining whether brakes apply to at least half the wheels of a vehicle by less complex provisions, in paragraph (4) of Schedule 3. (d) the extension to track-laying vehicles of certain exemptions applying only to wheeled vehicles. The reference to 7 passengers in former regulation 64(5) is effectively altered to 8 passengers (Sch. 3 para 4(d)).
17	14	10	<i>Vacuum or pressure brakes</i>
18	59(4) to (7), 64(4) to (7), 67(3), 75(4A), 79C(2), 101 101A 152, 153 & Sch 4	54	<i>Maintenance and efficiency of brakes</i>
19	126	70	<i>Application of brakes of trailers</i>
20	8	—	<i>General requirement as to wheels and tracks</i>
21	20	—	<i>Diameter of wheels</i>
22	12	7	<i>Springs and resilient material</i> Paragraph (3)(a)(iii) is extended to cover work on unmade roads.
23	11	6	<i>Wheel loads</i>
24	52, 56, 60, 65,	27, 31, 32, 37, 38	<i>Tyres</i> By item 1 in the Table, track-laying locomotives are permitted to use pneumatic tyres.

**Status:** Point in time view as at 31/03/2009.

**Status:** This revised version has been created from an electronic version contributed by Westlaw which was originally derived from the printed publication. **Read more** (See end of Document for details) **Changes to legislation:** There are currently no known outstanding effects for the The Road Vehicles (Construction and Use) Regulations 1986. (See end of Document for details)

NEW REGULATION NO	C&U 68, 77, 78, 79D	TLV	OLD REGULATION NO	SUBJECT MATTER AND DESCRIPTION OF SUBSTANTIVE CHANGES (changes mentioned in paragraphs 2–5 above are not repeated in this Annex)
				<p>In item 3 the maximum weight for the exemption of vehicles used for work on rough ground is omitted, as is the maximum weight limit for the exemption of track-laying works trucks.</p> <p>In item 4 tower wagons and vehicles fitted with fire escapes are added to the exemptions and the maximum weight limit on truck-laying works trucks is omitted.</p> <p>It is made clear in items 3, 4, 5 and 7, column 5 that the mixing of pneumatic and resilient tyres on the wheels of vehicle is not prohibited; it was previously prohibited for motor cycles and possibly also for motor cars but not for heavy motor cars or trailers.</p>
25	154	—		<i>Tyres loads and speed ratings</i>
26	108	—		<i>Mixing of tyres</i>
27	107	57		<i>Condition and maintenance of tyres</i>
28	—	9, 56		<i>Tracks</i>
29	102	54		<i>Maintenance of steering gear</i>
30	22, 100	14, 53		<i>View to the front</i>
31	25	16		<i>Glass</i>
32	26	—		<i>Glass</i>
33	23, 24, 24A	15		<p><i>Mirrors</i> Reference is made to Community Directive 85/196 as a permitted alternative (paragraph (5)). The reference to 7 passengers in former regulation 24(1) is altered to 8 passengers.</p> <p>A new uniform definition of “mirror” replaces various descriptions and definitions.</p> <p>The treatment of track-laying vehicles is assimilated to that of wheeled vehicles in Table I, item 1, class (d) and item 6, class (b).</p>
34	27, 28, 103	17, 54		<i>Windscreen wipers and washers</i>
35	18	11		<p><i>Speedometers</i> The requirements as to accuracy are omitted, as is the requirement, for vehicles first used before 1 April 1984, to indicate speed in either miles or kilometres per hour. Track-laying vehicles are effectively exempted from the requirement by virtue of the extension to them of the exemption for wheeled</p>

**Status:** Point in time view as at 31/03/2009.

**Status:** This revised version has been created from an electronic version contributed by Westlaw which was originally derived from the printed publication. **Read more** (See end of Document for details) **Changes to legislation:** There are currently no known outstanding effects for the The Road Vehicles (Construction and Use) Regulations 1986. (See end of Document for details)

NEW REGULATION NO	OLD REGULATION NO		SUBJECT MATTER AND DESCRIPTION OF SUBSTANTIVE CHANGES (changes mentioned in paragraphs 2–5 above are not repeated in this Annex) vehicles with a legal maximum speed of not more than 25 mph (no tracklaying vehicle is permitted to be driven at more than 20 mph).
	C&U	TLV	
36	98	52	<i>Maintenance of speedometers</i>
37	29	18	<i>Audible warning instruments</i> The previous exclusions have been simplified to a single exclusion of vehicles not driven at more than 20 mph. Two-tone horns are excepted from the requirement that any horn fitted to a vehicle shall be continuous and uniform and not strident.  The exemptions in revoked regulations 5 and 5AA, for vehicles complying with Community Directives, are withdrawn in respect of reversing alarms as the Directives do not cover reversing alarms.
38	—	—	<i>Motor cycle sidestands</i>
39	19	—	<i>Petrol tanks</i>
40	47	24	<i>Gas propulsion systems and gas-fired appliances</i>
41	—	—	<i>Construction of minibuses</i>
42	—	—	<i>Fire extinguishing apparatus for minibuses</i>
43	—	—	<i>First aid equipment for minibuses</i>
44	—	—	<i>Carriage of dangerous substances in minibuses</i>
45	44, 45	—	<i>Power-to-weight ratio</i> The definition of “relevant weight” is simplified.
46	17 (part)	—	<i>Seat belt anchorage points</i>
47	17 (part)	—	<i>Seat belts</i>
48	102A	—	<i>Maintenance of seat belts and anchorage points</i>
49	46B	—	<i>Rear under-run protection</i> The previous definition of “outermost part” is superfluous and has been omitted.
50	105A	—	<i>Maintenance of rear under-run protective device</i>
51	46C, 46D	—	<i>Sideguards</i>
52	105B	—	<i>Maintenance of Sideguards</i>
53	142	76	<i>Mascots</i> The reference to a mascot is extended to “mascot, emblem or other ornamental object” in order to remove any suggestion that the provision is limited to objects intended or considered to be lucky.

**Status:** Point in time view as at 31/03/2009.

**Status:** This revised version has been created from an electronic version contributed by Westlaw which was originally derived from the printed publication. **Read more** (See end of Document for details)**Changes to legislation:** There are currently no known outstanding effects for the The Road Vehicles (Construction and Use) Regulations 1986. (See end of Document for details)

NEW REGULATION NO	OLD REGULATION NO		SUBJECT MATTER AND DESCRIPTION OF SUBSTANTIVE CHANGES(changes mentioned in paragraphs 2–5 above are not repeated in this Annex)
	C&U	TLV	
54	116A	19, 55	<i>Silencers</i>
55	31A	—	<i>Noise limits—general</i> Provision is included in the Table to recognise conformity with Community Directive 84/424 as an additional option.
56	31C	—	<i>Noise limits—agricultural motor vehicles and industrial tractors</i>
57	31B, 116C	—	<i>Noise limits—motor cycles</i>
58	31	—	<i>Noise limits—vehicles not subject to regulations 55 and 57</i>  The effect of former regulation 31(2)(a) and (b) now appears in regulation 59.
59	31D	—	<i>Exceptions to regulations 55 to 58</i>
60	32	—	<i>Radio interference suppression</i> An exception is provided for amateur-built vehicles.
61	33, 38, 109 to 112	20, 21, 28	<i>Emission of smoke, vapour, gases and oily substances</i> An error in former regulation 111 is corrected.
62	39, 113	—	<i>Closets etc</i> Provisions related to hygiene have been omitted.
63	61, 66, 69, 72, 79	33, 39	<i>Wings</i> The 12 mph speed condition has been increased to 20 mph to reflect the 1984 Act. An exemption is provided for agricultural trailers which are not drawn at a speed exceeding 20 mph.
64	46E	—	<i>Spray suppression devices</i>
65	105C	—	<i>Maintenance of spray suppression devices for goods vehicles and buses</i>
66	42	—	<i>Plates</i> The inadvertent extension of the scope of the previous regulation 41(1)(C)(iv) to certain trailers which was brought about by SI 1981/1119 is corrected.
67	43	—	<i>Vehicle identification numbers</i> A minor modification dealing with compliance with Section 3 and 4 of the Annex to the Directive is introduced.
68	42A	—	<i>Plates—agricultural trailed appliances</i>
69	46	—	<i>Plates—motor cycles</i>
70	148	—	<i>Ministry plates</i>
71	46A, 80	40	<i>Marking of weights on certain vehicles</i>

**Status:** Point in time view as at 31/03/2009.

**Status:** This revised version has been created from an electronic version contributed by Westlaw which was originally derived from the printed publication. **Read more** (See end of Document for details)**Changes to legislation:** There are currently no known outstanding effects for the The Road Vehicles (Construction and Use) Regulations 1986. (See end of Document for details)

<i>NEW REGULATION NO</i>	<i>OLD REGULATION NO</i>		<i>SUBJECT MATTER AND DESCRIPTION OF SUBSTANTIVE CHANGES(changes mentioned in paragraphs 2–5 above are not repeated in this Annex)</i>
72	<i>C&amp;U</i> 151	<i>TLV</i> —	<i>Additional markings</i>
73	149	—	<i>Test date discs</i>
74	145	79	<i>Testing and inspection</i>
75–80	82– 95, 96A	26, 45–49	<p><i>Maximum permitted laden weight of a vehicle (75)</i></p> <p><i>Maximum permitted laden weight of a vehicle and trailer, other than an articulated vehicle (76)</i></p> <p><i>Maximum permitted laden weight of articulated vehicle (77)</i></p> <p><i>Maximum permitted wheel and axle weights (78)</i></p> <p><i>Maximum permitted weights for certain closely-spaced axles (79)</i></p> <p><i>Over-riding weight restrictions (80)</i></p> <p>Former Schedules 6 and 7 are assimilated into Schedule 11. References to plates and plated weights are omitted and eligibility is related simply to actual weights and braking performance. Other consequential simplifications are made.</p> <p>The braking requirement relevant to Schedule 11 is referred to as “the relevant braking requirement” and is defined, in simplified terms, in regulation 3. Special references to temporarily imported vehicles are omitted.</p> <p>Only maximum laden weights for track-laying locomotives are retained.</p> <p>The provisions of former TLV regulation 47, proviso, are applied to combinations in which either the drawing vehicle or the trailer is a wheeled vehicle.</p>
81, 82	139, 140	75	<p><i>Restrictions on use of vehicles carrying wide or long loads or having fixed appliances or apparatus</i></p> <p>Paragraphs (i) and (j) of regulation 81 are drafted so as to link the points from which measurements are taken with the full revised definitions of overall width and overall length in regulation 3. Regulations 81(k) and 82(10) are extended to horticultural and forestry implements.</p>
83	132, 135, 137	73	<p><i>Number of trailers</i> It is made clear that when agricultural motor vehicles draw non-agro-cultural trailers the normal rules for other motor vehicles apply.</p>

**Status:** This revised version has been created from an electronic version contributed by Westlaw which was originally derived from the printed publication. **Read more** (See end of Document for details)**Changes to legislation:** There are currently no known outstanding effects for the The Road Vehicles (Construction and Use) Regulations 1986. (See end of Document for details)

NEW REGULATION NO	OLD REGULATION NO		SUBJECT MATTER AND DESCRIPTION OF SUBSTANTIVE CHANGES(changes mentioned in paragraphs 2–5 above are not repeated in this Annex)
	C&U	TLV	
84	130	—	<i>Trailers drawn by motor cycles</i> The exemption for the drawing of broken down motor cycles is extended to include the whole of paragraph (1)(e).
85	137A	—	<i>Trailers drawn by agricultural motor vehicles</i>
86	128	72	<i>Distances between motor vehicles and trailers</i> The limitation to causes exceeding 1.5m is extended to track-laying vehicles.
87	136A	—	<i>Unbraked trailers</i> The definition of unbraked trailer now appears in regulation 3 and is amended to refer to braking systems in accordance with regulation 15 as well as regulation 16.  The wording of the regulation avoids any doubt that both the unladen weight of the trailer and the weight of its load have to be doubled for the purpose of determining whether the requirement is complied with.
88	128A	—	<i>Use of bridging plates between motor vehicle and trailer</i>
89	127	71	<i>Leaving trailers at rest</i> The option of a chock or other efficient device is extended to track-laying trailers.
90	133, 134	74	<i>Passengers in trailers</i> The references to the number of persons carried are altered to 8 exclusive of the driver.
91	138	78	<i>Attendants on trailers and certain other vehicles</i> The list of exemptions and paragraph (2) are extended generally to cover track-laying vehicles. An exemption for track-laying gas trailers is withdrawn in consequence of regulation 94.
92	129	—	<i>Attachment of sidecars</i>
93	141A	—	<i>Use of sidecars</i>
94	144A	—	<i>Use of gas propulsion systems</i>
95	144B	—	<i>Use of gas-fired appliances—general</i>
96	144C	—	<i>Use of gas fired appliances when a vehicle is in motion</i>
97	115	—	<i>Avoidance of excessive noise</i>
98	117	61	<i>Stopping of engine when stationary</i>
99	118	62, 63	<i>Use of audible warning instruments</i> The exemptions are extended to track-laying vehicles.
100	97	51	<i>Maintenance and use of vehicle so as not to be a danger etc</i> The formulation in former C&U regulation 97(2), which is more comprehensive than that in former TLV regulation 51(2), is applied to all vehicles.

**Status:** Point in time view as at 31/03/2009.

**Status:** This revised version has been created from an electronic version contributed by Westlaw which was originally derived from the printed publication. **Read more** (See end of Document for details)**Changes to legislation:** There are currently no known outstanding effects for the The Road Vehicles (Construction and Use) Regulations 1986. (See end of Document for details)

NEW REGULATION NO	OLD REGULATION NO		SUBJECT MATTER AND DESCRIPTION OF SUBSTANTIVE CHANGES(changes mentioned in paragraphs 2–5 above are not repeated in this Annex)
	C&U	TLV	
101	123	66	Parking in darkness
102	141	—	Passengers on motor cycles
103	122	67	Obstruction
104	119	64	Driver's control The “causing or permitting” provision is extended to track-laying vehicles.
105	125	—	Opening of doors
106	120	65	Reversing The “causing or permitting” provision is extended to track-laying vehicles.
107	124	69	Leaving motor vehicles unattended The exemptions are extended to track-laying vehicles.
108	144	—	Suspension of Implements
109	143	—	Television sets
Schedules			
1	1	1	Regulations revoked by regulation 2
2	—	—	Community Directives and ECE Regulations
3	—	—	Braking requirements See under regulation 15
4	3	3	Gas containers Reference to bars are converted to references to N/mm <sup>2</sup> .
5	3A	—	Gas systems
6	—	—	Construction of minibuses
7	—	—	Fire extinguishing apparatus and first aid equipment for minibuses
8	2	—	Plates for certain vehicles In Part III, paragraph 1, the option of measuring power in accordance with ECE Regulation 24 is introduced.
9	12, 12A	—	Plates for motor cycles
10	11	—	Ministry Plate
11	7	—	Maximum permitted weights etc.
12	8	—	Wide or long loads



**Status:** Point in time view as at 31/03/2009.**Status:** This revised version has been created from an electronic version contributed by Westlaw which was originally derived from the printed publication. **Read more** (See end of Document for details)**Changes to legislation:** There are currently no known outstanding effects for the The Road Vehicles (Construction and Use) Regulations 1986. (See end of Document for details)**ANNEX B****LOCATION OF THESE REGULATIONS AND SCHEDULES IN THE FORMER REGULATIONS****A. C & U REGULATIONS**

<i>Old Reg</i>	<i>New Reg</i>	<i>Old Reg</i>	<i>New Reg</i>	<i>Old Reg</i>	<i>New Reg</i>
1	1	41	previously revoked	80	8, 71
2	2			80A	10
3	3	42	66	81	previously revoked
4	4	42A	68		
5		43	67	82–95	75–80
5A		44		95A	9
		45	45		
5AA	omitted			96	previously revoked
5B		46	69		
6		46A	71	96A	75, 76
7	5	46B	49	97	100
8	20	46C		98	36
		46D	51		
9	7			99	omitted
		46E	65	100	30
9A	13	47	40	101	
				101A	18
9B	14	48	8		
10	9	49	78	102	29
11	23	50		102A	48
		51	16		
12	22			103	34
13	16	52	24	104	39
14	17	53	8	105	previously revoked
14A	15	54	11		
15		55	16	105A	50
16	omitted				
		56	24	105B	52

**Status:** Point in time view as at 31/03/2009.

**Status:** This revised version has been created from an electronic version contributed by Westlaw which was originally derived from the printed publication. **Read more** (See end of Document for details)**Changes to legislation:** There are currently no known outstanding effects for the The Road Vehicles (Construction and Use) Regulations 1986. (See end of Document for details)

<i>Old Reg</i>	<i>New Reg</i>	<i>Old Reg</i>	<i>New Reg</i>	<i>Old Reg</i>	<i>New Reg</i>
17	46, 47	57	8	105C	65
18	35	58	11	106	previously revoked
19	39	59	16, 18		
20	21	60	24	107	27
21	omitted	61	63	108	26
22	30	62	8	109	
23		63	11	110	
				111	61
24	33	64	16, 18		
24A		65	24	112	
25	31	66	63	113	62
26	32	67	16, 18	114	omitted
27		68	24	115	97
28	34				
		69	63	116	omitted
29	37	69A	37	116A	54
30	54	70	8	116B	omitted
31	58	71	16	116C	57
31A	55	72	63	117	98
31B	57	73	previously revoked	118	99
31C	56			119	104
31D	59	74	8	120	106
31E	55	74A	12	121	omitted
32	60	75		122	103
		76	16		
33				123	101
34		77		124	107
		78	24		
35				125	105
36	61				
		79	63	126	19
37		79A	8	127	89

**Status:** Point in time view as at 31/03/2009.

**Status:** This revised version has been created from an electronic version contributed by Westlaw which was originally derived from the printed publication. **Read more** (See end of Document for details)**Changes to legislation:** There are currently no known outstanding effects for the The Road Vehicles (Construction and Use) Regulations 1986. (See end of Document for details)

<i>Old Reg</i>	<i>New Reg</i>	<i>Old Reg</i>	<i>New Reg</i>	<i>Old Reg</i>	<i>New Reg</i>
38		79B	11	128	86
39	62	79C	16, 18	128A	88
40	omitted	79D	24	129	92

<i>Old Reg</i>	<i>New Reg</i>	<i>Old Reg</i>	<i>New Reg</i>	<i>Old Sch.</i>	<i>New Sch.</i>
130	84	141A	93	1	1
131	previously revoked	142	53	2	6
		143	109	3	4
132	83	144	108	3A	5
133		144A	94	4	Reg 18
134	90				
		144B	95	4A	Reg 15
135	93	144C	96	5	previously revoked
136	7	145	74		
136A	87	146		6	omitted
			omitted		
		147			
136B	8			7	11
137	83	148	70	8	12
137A	85	149	73	9	Reg 58
138	91	150	80	9A	omitted
138A	12	151	72	10	omitted
139	81	152		11	10
			18		
		153			
140	82			12	
					9
				12A	
141	102	154	25		

**B. TLV REGULATIONS**

<i>Old Reg</i>	<i>New Reg</i>	<i>Old Reg</i>	<i>New Reg</i>	<i>Old Reg</i>	<i>New Reg</i>
1	1	28		56	28
		29	16		

**Status:** Point in time view as at 31/03/2009.

**Status:** This revised version has been created from an electronic version contributed by Westlaw which was originally derived from the printed publication. **Read more** (See end of Document for details)**Changes to legislation:** There are currently no known outstanding effects for the The Road Vehicles (Construction and Use) Regulations 1986. (See end of Document for details)

<i>Old Reg</i>	<i>New Reg</i>	<i>Old Reg</i>	<i>New Reg</i>	<i>Old Reg</i>	<i>New Reg</i>
2	2			57	27
3	3	30	8	58	61
4	4	31	24	59	omitted
		32			
4A	previously revoked			60	97
		33	63	61	98
5	7	34	7	62	99
				63	
6	23	35	8		
7	22	36	16	64	104
8	16	37	24	65	106
		38			
9	28			66	omitted
10	17	39	63	67	103
11	35	40	71	68	101
12	21	41		69	107
13	omitted	42		70	19
14	30	43	previously revoked	71	89
15	33	44		72	86
16	31	45	75	73	83
17	34	46	75	74	90
18	37	47	76	75	81, 82
19	54	48	75, 78	76	53
20		49	75	77	omitted
21	61				
		50	78	78	91
21A		51	100	79	74
22	previously revoked	52	36	Old Sch.	New Sch.
23		53	30		
24	40	54	18, 29, 34		
25	8	54A	previously revoked	I	I
26	75			II, IV, V	Previously revoked

**Status:** Point in time view as at 31/03/2009.

**Status:** This revised version has been created from an electronic version contributed by Westlaw which was originally derived from the printed publication. **Read more** (See end of Document for details)**Changes to legislation:** There are currently no known outstanding effects for the The Road Vehicles (Construction and Use) Regulations 1986. (See end of Document for details)

<i>Old Reg</i>	<i>New Reg</i>	<i>Old Reg</i>	<i>New Reg</i>	<i>Old Reg</i>	<i>New Reg</i>
27	24	55	54		
				III	4

**Status:**

Point in time view as at 31/03/2009.

**Status:**

This revised version has been created from an electronic version contributed by Westlaw which was originally derived from the printed publication.

**Read more****Changes to legislation:**

There are currently no known outstanding effects for the The Road Vehicles (Construction and Use) Regulations 1986.