

## SCHEDULE 7

### <sup>F1</sup>PART III

---

#### Textual Amendments

- F1** Sch. 7 Pt. 3: words “or 6” inserted in first diagram after “Category 5” (4.1.2010) by [The Road Vehicles Lighting and Goods Vehicles \(Plating and Testing\) \(Amendment\) Regulations 2009 \(S.I. 2009/3220\)](#), regs. 1, **11(3)**
- 

#### Commencement Information

- I1** Sch. 7 Pt. III in force at 1.11.1989, see [reg. 1\(1\)](#)

**Changes to legislation:** There are currently no known outstanding effects for the The Road Vehicles Lighting Regulations 1989, PART III. (See end of Document for details)

### PART III

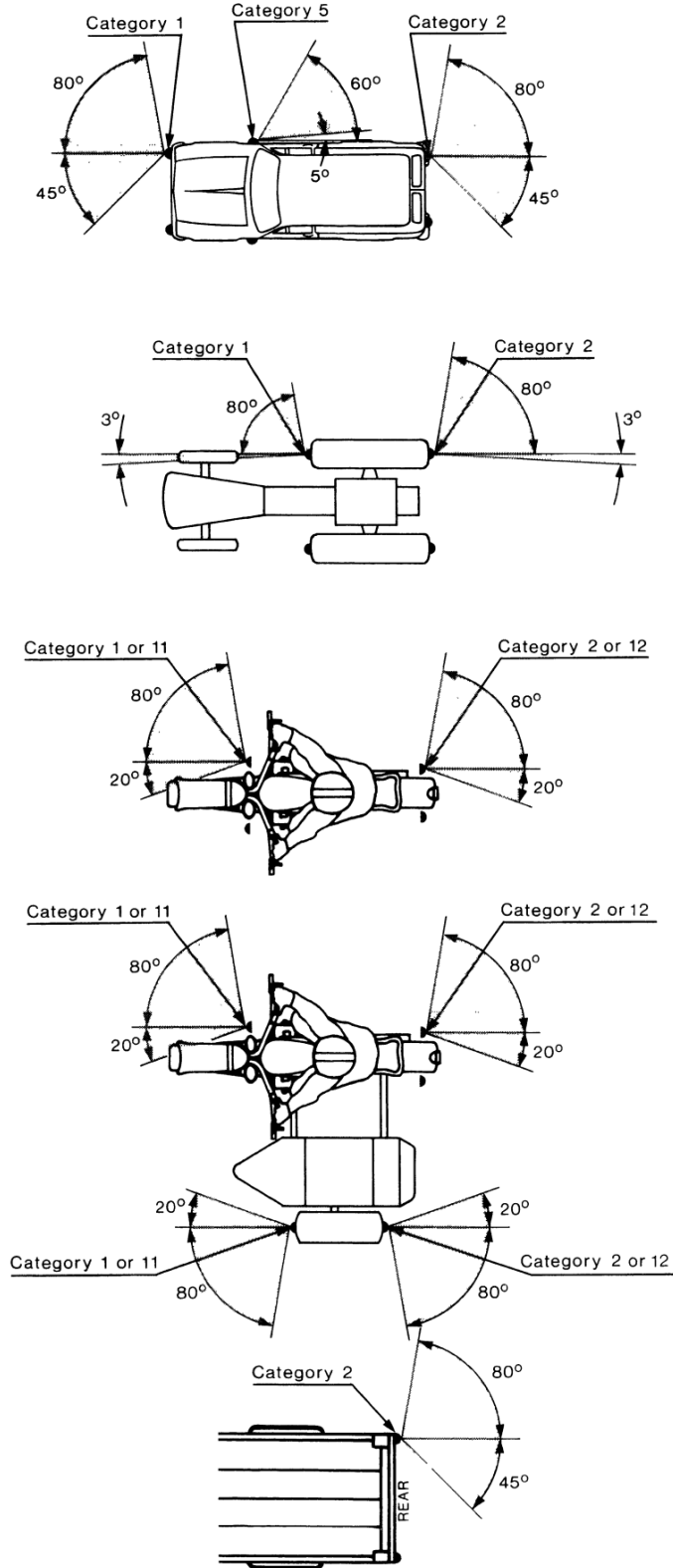

**Changes to legislation:**

There are currently no known outstanding effects for the The Road Vehicles Lighting Regulations 1989, PART III.