S T A T U T O R Y I N S T R U M E N T S

2000 No. 1970

DISABLED PERSONS

The Public Service Vehicles Accessibility Regulations 2000

Made - - - - - 20th July 2000

Laid before Parliament 24th July 2000

Coming into force - - 30th August 2000

ARRANGEMENT OF REGULATIONS

PART I

PRELIMINARY

1. Citation, commencement and extent
2. Interpretation

PART II

APPLICATION OF REGULATIONS, EXEMPTIONS AND RECOGNITION

3. Application
4. Exemptions
5. Recognition of EEA equivalent requirements

PART III

ACCESSIBILITY CERTIFICATES

6. Introductory
7. Applications and fees for accessibility certificates
8. Accessibility certificate

PART IV

APPROVAL OF A VEHICLE AS A TYPE VEHICLE

9. Introductory
10. Applications for type vehicle approval
11. Copies of drawings and specifications
12. Fees for approval as a type vehicle

[DOT 8886]

PART V

DECLARATIONS OF CONFORMITY TO A TYPE VEHICLE

13. Introductory
14. Form of declaration of conformity

PART VI

CONFORMITY CERTIFICATES

15. Introductory
16. Form of conformity certificate
17. Fee for conformity certificate

PART VII

MISCELLANEOUS

18. Issue of duplicate documentation
19. Reviews and appeals

SCHEDULES

1. Wheelchair accessibility requirements
2. General accessibility requirements for single-deck and double-deck buses
3. General accessibility requirements for single-deck and double-deck coaches
4. Accessibility certificate
5. Form of declaration of conformity to an approved type vehicle
6. Form of conformity certificate

The Secretary of State, in exercise of the powers conferred upon him by sections 40(1), (2) and (6), 41(2), 42(3), (4) and (5), 44(1)(b), 2(b) and (4), 45(1) and 67 of the Disability Discrimination Act 1995 ("the Act") and of all other powers enabling him in that behalf and after consultation with the Disabled Persons Transport Advisory Committee and such other representative organisations as he thought fit in accordance with section 40(7) of the Act and with such representative organisations as he thought fit in accordance with section 45(4) of the Act, hereby makes the following Regulations:

PART I

PRELIMINARY

Citation, commencement and extent

1. These Regulations may be cited as the Public Service Vehicles Accessibility Regulations 2000 and shall come into force on 30th August 2000.

(a) 1995 c. 50

Interpretation

2.—(1) In these Regulations—

“the 1970 Directive” means Council Directive 70/156/EEC of 6 February 1970 on the approximation of the laws of the member states relating to the type-approval of motor vehicles and their trailers(), as last amended by Commission Directive 98/14/EC of 6 February 1998();

“the 1981 Regulations” means the Public Service Vehicles (Conditions of Fitness, Equipment, Use and Certification) Regulations 1981();

“accessibility certificate” means a certificate issued by a vehicle examiner in accordance with Part III;

“bus” means a public service vehicle designed and constructed for the carriage of both seated and standing passengers which is of category M₂ or M₃ (as defined in Annex II(A) to the 1970 Directive) and has a capacity exceeding 22 passengers, in addition to the driver;

“coach” means a public service vehicle designed and constructed for the carriage of seated passengers only which is of category M₂ or M₃ (as defined in Annex II(A) to the 1970 Directive) and has a capacity exceeding 22 passengers, in addition to the driver;

“conformity certificate” means a certificate issued by a vehicle examiner in accordance with Part VI;

“declaration of conformity” means a declaration made by an authorised person in accordance with Part V;

“double-deck”, in relation to a bus or coach, means that the spaces provided for the passengers are arranged (at least in one part) on two superimposed levels and that space for standing passengers is not provided on the upper deck;

“EEA State” means a State which is a contracting party to the Agreement on the European Economic Area signed at Oporto on 2nd May 1992 as adjusted by the Protocol signed in Brussels on 17th March 1993(d);

“local service” has the same meaning as in section 2 of the Transport Act 1985(e);

“motor vehicle” has the same meaning as in Annex II(A) to the 1970 Directive;

“regulated public service vehicle” means any public service vehicle to which these Regulations apply in accordance with regulation 3(1);

“scheduled service” means a service, using one or more public service vehicles, for the carriage of passengers at separate fares—

(a) along specified routes,

(b) at specified times, and

(c) with passengers being taken up and set down at pre-determined stopping points,

but does not include a tour service;

“seated passengers” means the number of seated passengers that a vehicle may carry in accordance with the Public Service Vehicles (Carrying Capacity) Regulations 1984(f);

“standing passengers” means the number of standing passengers that a vehicle may carry in accordance with the Public Service Vehicles (Carrying Capacity) Regulations 1984;

“tour service” means a service where a public service vehicle is used for or in conjunction with the carriage of passengers to a particular location, or particular locations, and back to their point of departure;

“type vehicle approval” means an approval given by the Secretary of State in accordance with Part IV;

“weight” means design weight as defined in regulation 3(2) of the Road Vehicles (Construction and Use) Regulations 1986(g) and the words “weighs” and “weighing” shall be construed accordingly;

And other expressions used in Schedules 1 to 3 have the meanings given to them respectively in paragraph 1 of those Schedules.

(a) O.J. L. 42, 23.02.70, p. 1.

(b) O.J. L. 091, 25.03.98, p. 1.

(c) S.I. 1981/257.

(d) Cmnd. 2847.

(e) 1985 c. 67.

(f) S.I. 1984/1406.

(g) S.I. 1986/1078; to which there are amendments not relevant to these Regulations.

(2) For the purpose of these Regulations, the date on which a regulated public service vehicle is “first used” shall be taken to be such date as is the earlier of the relevant dates mentioned below applicable to that vehicle, that is to say—

- (a) in the case of a vehicle registered under the Roads Act 1920^(a), the Vehicles (Excise) Act 1949^(b), the Vehicles (Excise) Act 1962^(c), the Vehicles (Excise) Act 1971^(d) or the Vehicle Excise and Registration Act 1994^(e), the relevant date is the date on which it was first so registered; and
 - (b) in each of the following cases:
 - (i) a vehicle which is being or has been used under a trade licence within the meaning of section 11(1) of the Vehicle Excise and Registration Act 1994 (otherwise than for the purposes of demonstration or testing or of being delivered from premises of the manufacturer by whom it was made, or of a distributor of vehicles or dealer in vehicles, to premises of a distributor of vehicles, dealer in vehicles or purchaser thereof or to premises of a person obtaining possession thereof under a hiring agreement or hire purchase agreement);
 - (ii) a vehicle belonging, or which has belonged, to the Crown which is or was used or appropriated for use for naval, military or air force purposes;
 - (iii) a vehicle belonging, or which has belonged, to a visiting force or a headquarters or defence organisation to which (in each case) the Visiting Forces and International Headquarters (Application of Law) Order 1965^(f) applies;
 - (iv) a vehicle which has been used on roads outside Great Britain and which has been imported into Great Britain; and
 - (v) a vehicle which has been used otherwise than on roads after being sold or supplied by retail and before being registered;
- the relevant date is the date of manufacture of the vehicle.

In case (v) above, “sold or supplied by retail” means sold or supplied otherwise than to a person acquiring the vehicle solely for the purpose of resale or re-supply for valuable consideration.

PART II

APPLICATION OF REGULATIONS, EXEMPTIONS AND RECOGNITION

Application

3.—(1) These Regulations apply to public service vehicles of the types described respectively in paragraphs (2) to (7) (a “regulated public service vehicle”) in the manner and to the extent set out in this Part.

(2) A single-deck bus which weighs more than 7.5 tonnes and is in use on or after 31st December 2000 shall require a certificate referred to in paragraph (8) relating to Schedules 1 and 2, except that a single-deck bus which—

- (a) is first used before that date; or
- (b) is manufactured before 1st October 2000,

shall not require any certificate relating to Schedules 1 and 2 until 1st January 2016.

(3) A single-deck bus which weighs 7.5 tonnes or less and is in use on or after 31st December 2000 shall require a certificate referred to in paragraph (8) relating to Schedule 2, except that a single-deck bus which—

- (a) is first used before that date; or
- (b) is manufactured before 1st October 2000,

shall not require a certificate relating to Schedule 2 until 1st January 2015.

(a) 1920 c. 72.
 (b) 1949 c. 89.
 (c) 1962 c. 13.
 (d) 1971 c. 10.
 (e) 1994 c. 22.
 (f) S.I. 1965/1536.

(4) Without prejudice to paragraph (3), a single-deck bus which weighs 7.5 tonnes or less and is in use on or after 1st January 2005 shall require a certificate referred to in paragraph (8) relating to Schedule 1, except that a single-deck bus which—

- (a) is first used before that date; or
- (b) is manufactured before 1st October 2004,

shall not require a certificate relating to Schedule 1 until 1st January 2015.

(5) A double-deck bus which is in use on or after 31st December 2000 shall require a certificate referred to in paragraph (8) relating to Schedules 1 and 2, except that a double-deck bus which—

- (a) is first used before that date; or
- (b) is manufactured before 1st October 2000,

shall not require any certificate relating to Schedules 1 and 2 until 1st January 2017.

(6) A single-deck or double-deck coach which is in use on or after 31st December 2000 shall require a certificate referred to in paragraph (8) relating to Schedule 3, except that a single-deck or double-deck coach which—

- (a) is first used before that date; or
- (b) is manufactured before 1st October 2000,

shall not require a certificate relating to Schedule 3 until 1st January 2020.

(7) Without prejudice to paragraph (6), a single-deck or double-deck coach which is in use on or after 1st January 2005 shall require a certificate referred to in paragraph (8) relating to Schedule 1, except that a single-deck or double-deck coach which—

- (a) is first used before that date; or
- (b) is manufactured before 1st October 2004,

shall not require a certificate relating to Schedule 1 until 1st January 2020.

(8) The certificates referred to in paragraphs (2) to (7) are the certificates (and any other associated approval and declaration) issued in accordance with Parts III to VI and which, when so issued, signify the compliance and conformity of the vehicle concerned with the Schedules specified respectively in those paragraphs.

(9) In paragraphs (2) to (7)—

- (a) “first used” is to be construed in accordance with regulation 2(2); and
- (b) references to a vehicle being “used” or “in use” means the regulated public service vehicle is being used to provide either a local service or a scheduled service.

Exemptions

4.—(1) The requirements specified in regulation 3 do not apply to a regulated public service vehicle which is—

- (a) an off-road vehicle within the meaning of paragraph 4 of Annex II(A) to the 1970 Directive;
- (b) used in accordance with section 19 of the Transport Act 1985(a);
- (c) used for the secure transport of persons (including prisoners);
- (d) specifically designed for the carriage of injured or sick persons;
- (e) used by or for purposes of a Minister of the Crown or government department or in the service of a visiting force or headquarters; or
- (f) a vehicle in respect of which twenty years have elapsed since the date of its first use on a road and which is not used to provide a local service or a scheduled service for more than 20 days in any calendar year.

(2) The requirements of the Schedules specified below shall not come into effect in relation to any regulated public service vehicle to which those Schedules may apply until 1 January 2003; and, accordingly, any certificate, approval or declaration issued, given or made in accordance with Parts III to VI shall be valid notwithstanding that the vehicle does not comply with those requirements.

(a) 1985 c. 67.

The requirements are those specified in—

- (a) paragraph 5(3)(b) to (e) of Schedule 1 (boarding lifts and ramps); and
- (b) paragraphs 7(3)(c) and 4(c) of Schedule 3 (to the extent that they apply to a route number display and destination display fitted in accordance with paragraph 7(1)(b) of that Schedule).

Recognition of EEA equivalent requirements

5. Where there is produced to the Secretary of State evidence that satisfies him that a regulated public service vehicle has been found by the competent authority of another EEA State to conform with requirements that are equivalent to all, or some of the requirements prescribed for that vehicle under these Regulations, that vehicle shall, by virtue of that evidence, be regarded as conforming with those (and only those) requirements for the purposes of these Regulations.

PART III

ACCESSIBILITY CERTIFICATES

Introductory

6. This Part has effect with respect to the issue by a vehicle examiner in respect of a particular regulated public service vehicle under section 41(1)(a) of the Act of a certificate that such provisions of these Regulations as relate to that vehicle are satisfied in respect of it, and in this Part, Part VII and Schedule 4 the certificate so issued is referred to as an “accessibility certificate”.

Applications and fees for accessibility certificates

7.—(1) Every application for an accessibility certificate shall be made to the Secretary of State in writing.

(2) The prescribed fee for an application for an accessibility certificate—

- (a) on the first application in respect of the vehicle—
 - (i) where the vehicle is required to comply with only one of Schedules 1, 2 or 3, is £28.00, or
 - (ii) where the vehicle is required to comply with either Schedules 1 and 2, or Schedules 1 and 3, is £55.00; and
- (b) on any subsequent application—
 - (i) where the vehicle is required to comply with only one of Schedules 1, 2 or 3, is £10.00, or
 - (ii) where the vehicle is required to comply with either Schedules 1 and 2, or Schedules 1 and 3, is £20.00.

Accessibility certificate

8. An accessibility certificate shall contain the information set out in Schedule 4.

PART IV

APPROVAL OF A VEHICLE AS A TYPE VEHICLE

Introductory

9. This Part has effect with respect to the approval by the Secretary of State under section 42(1) of the Act of a particular regulated public service vehicle as satisfying the provisions of these Regulations, and in this Part and in Part V and Schedules 5 and 6 a vehicle which has been so approved is referred to as a “type vehicle” and an approval so given (which may be in such form as the Secretary of State may determine) is referred to as a “type vehicle approval”.

Applications for type vehicle approval

10.—(1) Every application for the approval of a vehicle as a type vehicle shall be made to the Secretary of State in writing.

(2) Where the applicant represents that the vehicle in respect of which the application is made—

- (a) conforms substantially to a vehicle already approved as a type vehicle, or
- (b) has a chassis which conforms to the chassis of a vehicle which has already been approved as a type vehicle, or
- (c) has a body which conforms to the body of a vehicle which has already been approved as a type vehicle,

the application may, with the approval of the Secretary of State, be made by way of reference to such type vehicle.

(3) Where the applicant represents that the vehicle in respect of which the application is made has a chassis and a body which have formed parts of different vehicles which have already been approved as type vehicles, the application may, with the approval of the Secretary of State, be made by way of reference to such type vehicles.

(4) Every application mentioned in paragraphs (1) to (3) shall be accompanied by two sets of such working drawings and such detailed specifications and calculations as the Secretary of State may require, and the applicant shall, in respect of every such application, give the Secretary of State the facility to inspect and test the vehicle.

Copies of drawings and specifications

11. On being given a type vehicle approval, the person who applied for it shall supply to the Secretary of State such number of copies of the relevant working drawings, specifications and calculations as the Secretary of State may require.

Fees for approval as a type vehicle

12.—(1) The prescribed fees for the approval of a vehicle as a type vehicle are as follows.

(2) Subject to paragraphs (3) and (4), for an application made on the basis of a representation under each of sub-paragraphs (a) to (c) of regulation 10(2), the prescribed fee—

- (a) where the vehicle is required to comply with only one of Schedules 1, 2 or 3, is £160.00, or
- (b) where a regulated public service vehicle is required to comply with either Schedules 1 and 2, or Schedules 1 and 3, is £320.00.

(3) This paragraph applies where—

- (a) an approval is given pursuant to an application made on the basis of a representation only under sub-paragraph (a) of regulation 10(2); and
- (b) the Secretary of State is satisfied that the vehicle in respect of which the application is made conforms (except in unimportant details) to a vehicle already approved as a type vehicle; and
- (c) no inspection of the vehicle is made.

(4) Where paragraph (3) applies, the prescribed fee—

- (a) where the vehicle is required to comply with only one of Schedules 1, 2 or 3, is £15.00, or
- (b) where the vehicle is required to comply with either Schedules 1 and 2, or Schedules 1 and 3, is £30.00.

(5) For an approval given pursuant to an application under regulation 10(3), the prescribed fee—

- (a) where the vehicle is required to comply with only one of Schedules 1, 2 or 3, is £79.00, or
- (b) where the vehicle is required to comply with either Schedules 1 and 2, or Schedules 1 and 3, is £158.00.

- (6) In any other case, the prescribed fee—
- (a) where the vehicle is required to comply with only one of Schedules 1, 2 or 3, is £350.00, or
 - (b) where the vehicle is required to comply with either Schedules 1 and 2, or Schedules 1 and 3, is £690.00.
- (7) Where approval is refused, the Secretary of State may retain such portion of any fee as he considers appropriate for the work he has carried out inspecting the vehicle concerned.

PART V

DECLARATIONS OF CONFORMITY TO A TYPE VEHICLE

Introductory

13. This Part applies with respect to the making by an authorised person (being a person authorised by the Secretary of State for the purposes of section 42(3) of the Act) of a declaration under that section that a particular regulated public service vehicle conforms in design, construction and equipment with a type vehicle, and in this Part and in Schedule 5 a declaration so made is referred to as a “declaration of conformity”.

Form of declaration of conformity

14. A declaration of conformity shall be made in the form set out in Schedule 5.

PART VI

CONFORMITY CERTIFICATES

Introductory

15. This Part has effect with respect to the issue by a vehicle examiner of a certificate under section 42(4) of the Act that a declaration of conformity has been issued in respect of a regulated public service vehicle, and a certificate so issued is referred to in this Part and in Part VII and Schedule 6 as a “conformity certificate”.

Form of conformity certificate

16. A conformity certificate shall be issued in the form set out in Schedule 6.

Fee for conformity certificate

17. The prescribed fee for a conformity certificate is £15.00.

PART VII

MISCELLANEOUS

Issue of duplicate documentation

18.—(1) If an accessibility certificate or a conformity certificate has been lost or destroyed, the owner of the vehicle to which it relates shall forthwith notify the Secretary of State and the Secretary of State, if satisfied that the certificate has been lost or destroyed, may issue a copy of the certificate marked as a duplicate.

(2) If a certificate referred to in paragraph (1) subsequently comes into the possession of the owner of the vehicle he shall forthwith return it to the Secretary of State.

(3) If an accessibility certificate or a conformity certificate becomes defaced or illegible, the owner of the vehicle to which it relates shall return it to the Secretary of State and the Secretary of State may issue a copy of the certificate marked as a duplicate.

(4) A copy of a certificate issued and marked as a duplicate in accordance with paragraph (1) or (3) shall have the same effect as the original certificate.

(5) The prescribed fee for the issue of a copy of a certificate under this regulation is £10.00.

Reviews and appeals

19.—(1) This regulation applies where the Secretary of State refuses to issue a type vehicle approval under section 42(1) of the Act and where a vehicle examiner refuses to issue an accessibility certificate under section 41(1)(a) of the Act or a conformity certificate under section 42(4) of the Act.

(2) Every request for a review made under section 44(1)(b) of the Act—

- (a) shall be made in writing to the Secretary of State; and
- (b) shall be accompanied by a statement of the grounds of the review.

(3) For the purposes of section 44(1)(b) of the Act, the prescribed time for requesting a review or for making an appeal is 28 days from the date when the Secretary of State refuses an application for the approval of a vehicle under section 42(1) of the Act.

(4) Every appeal under section 44(3) of the Act—

- (a) shall be made in writing to the Secretary of State; and
- (b) shall be accompanied by a statement of the grounds of the appeal.

(5) For the purposes of section 44(4) of the Act, the prescribed period for making an appeal is 28 days from the date when a vehicle examiner refuses to issue an accessibility certificate or a conformity certificate.

Signed by authority of the
Secretary of State for the Environment,
Transport and the Regions

Keith Hill
Parliamentary Under Secretary of State,
Department of the Environment,
Transport and the Regions

20th July 2000

SCHEDULE 1

Regulation 3

PART I

WHEELCHAIR ACCESSIBILITY REQUIREMENTS

Definitions

1. In this Schedule—

“the 1976 Directive” means Council Directive 76/115/EEC (as amended) of 18 December 1975 on the approximation of the laws of the member states relating to anchorages for motor vehicle safety belts(a),

“the 1977 Directive” means Council Directive 77/541/EEC (as amended) of 28 June 1977 on the approximation of the laws of the member states relating to safety belts and restraint systems of motor vehicles(b),

“boarding lift” means a lift fitted to a regulated public service vehicle for the purpose of allowing wheelchair users to board and alight from the vehicle;

“boarding ramp” means a ramp fitted to a regulated public service vehicle for the purpose of allowing wheelchair users to board and alight from the vehicle;

“contrast” means a contrast in the amount of light which is reflected by the surfaces of the parts of a regulated public service vehicle or its equipment which is required by these Regulations to contrast;

“dynamic test” means a test which complies with the requirements of paragraph 3(7);

“exit” means an exit from a regulated public service vehicle but does not include an exit which is provided for use only in case of emergency;

“gangway” means the space provided for obtaining access from any entrance to the passengers’ seats or from any such seat to an exit other than an emergency exit, but does not include a staircase or any space in front of a seat or row of seats which is required only for the use of passengers occupying the seat or row of seats;

“g” means 9.81 m/s²;

“kg” means kilogram(s);

“km/h” means kilometre(s) per hour;

“mm” means millimetre(s);

“m/s” means metre(s) per second and “m/s²” means metre(s) per second per second;

“N” means newton(s);

“optical device” means any system (including a mirror, closed circuit television and optical cable) which provides the driver of a regulated public service vehicle with a view of an area of the vehicle;

“portable ramp” means a ramp which is carried on a regulated public service vehicle for the purpose of allowing wheelchair users to board and alight from the vehicle;

“reference wheelchair” means an occupied wheelchair having the dimensions shown in diagram A of Part II to this Schedule;

“seat” means a seat intended for use by passengers and, accordingly, does not include the driver’s seat or any other seat intended to use solely by a crew member;

“static test” means a test which complies with the requirements of paragraph 3(5) and which applies the forces specified in paragraph 3(6);

“wheelchair restraint system” means a system which is designed to keep a wheelchair restrained within the wheelchair space;

“wheelchair user” means a disabled person using a wheelchair; and

“wheelchair user restraint” means a system which is designed to keep a wheelchair user restrained in the wheelchair.

Wheelchair spaces

- 2.—(1) A regulated public service vehicle shall be fitted with not less than one wheelchair space.
- (2) Any wheelchair space shall be fitted to the lower deck of a double-deck bus or double-deck coach.
- (3) Any wheelchair space on a regulated public service vehicle—
 - (a) shall comply with the requirements of paragraph 3; or

(a) O.J. L. 024, 30.01.76, p. 6; relevant amendments are Council Directives 81/575/EEC (O.J. L. 209, 29.07.81, p. 30), 82/318/EEC (O.J. L. 139, 19.05.82, p. 9) and 90/629/EEC (O.J. L. 341, 6.12.90, p. 14);

(b) O.J. L. 220, 29.08.77, p. 95; relevant amendments are Council Directives 81/576/EEC (O.J. L. 209, 29.07.81, p. 32), 82/319/EEC (O.J. L. 139, 19.05.82, p. 17) and 90/628/EEC L. 187 26.07.96, p. 95 (O.J. L. 341, 6.12.90, p. 1).

- (b) where the vehicle is adapted to carry standing passengers and is not fitted with any seat belts for passengers which are required to be fitted by regulation, may comply with the requirements of paragraph 4 as an alternative to the requirements of paragraph 3.

Forward-facing wheelchairs

3.—(1) Any wheelchair space fitted to a regulated public service vehicle shall comply with the following requirements—

- (a) a wheelchair space shall not be less than—
 - (i) 1300mm measured in the longitudinal plane of the vehicle;
 - (ii) 750mm measured in the transverse plane of the vehicle; and
 - (iii) 1500mm measured vertically from any part of the floor of the wheelchair space;
- (b) a wheelchair space shall allow the carriage of a wheelchair and a wheelchair user facing the front of the vehicle;
- (c) a wheelchair space shall be fitted with a wheelchair restraint system suitable for general wheelchair application;
- (d) a wheelchair space shall be fitted with a wheelchair user restraint system which shall comprise a minimum of two anchorage points and a pelvic restraint (lap belt) designed and constructed of components intended to perform in a similar manner to those of a seat belt conforming to the 1977 Directive;
- (e) any wheelchair user restraint or wheelchair restraint system fitted to a wheelchair space shall be capable of being easily released in the case of an emergency;
- (f) any wheelchair restraint system shall either—
 - (i) meet the dynamic test requirements described in sub-paragraph (7) and be securely attached to vehicle anchorages meeting the static test requirements in sub-paragraph (5); or
 - (ii) be securely attached to vehicle anchorages such that the combination of restraint and anchorages meets the requirements of sub-paragraph (7) when the anchorages comply with sub-paragraph (7)(d)(ii); and
- (g) any wheelchair user restraint shall either—
 - (i) meet the test requirements described in sub-paragraph (8) and be securely attached to vehicle anchorages meeting the static test requirements in sub-paragraph (5); or
 - (ii) be securely attached to vehicle anchorages such that the combination of restraint and anchorages meets the test requirements described in sub-paragraph (8) when fitted to a representative section of the vehicle structure as described in sub-paragraph (5)(g).

(2) One or more seats which are capable of being tipped, folded or otherwise moved may lie within the volume specified in sub-paragraph (1)(a) or within the gangway specified in paragraph 7 provided that the seat is capable of being easily moved out of the volume or out of the gangway. In the case of a single-deck or double-deck coach, this may include a seat which may be quickly dismantled or removed provided that the seat can be safely stowed.

(3) The clear space in front of any seat may lie within the volume specified in sub-paragraph (1)(a) or within the gangway specified in paragraph 7.

(4) There shall be a sign on or near a seat specified in sub-paragraphs (2) and (3) stating the following “Please give up this seat for a wheelchair user” or stating words of equivalent meaning.

(5) A static test shall be carried out on the anchorage points for both the wheelchair restraint system and the wheelchair user restraint in accordance with the following requirements—

- (a) the forces specified in sub-paragraph (6) shall be applied by means of a device reproducing the geometry of the wheelchair restraint system;
- (b) the forces specified in sub-paragraph (6) shall be applied by means of a device reproducing the geometry of the wheelchair user restraint and by means of a traction device specified in paragraph 5.3.4 of Annex 1 of the 1976 Directive;
- (c) the forces in (a) and (b) above shall be applied simultaneously in the forward direction and at an angle of $10^{\circ} \pm 5^{\circ}$ above the horizontal plane;
- (d) the forces in (a) above shall be applied in the rearward direction and at an angle of $10^{\circ} \pm 5^{\circ}$ above the horizontal plane;
- (e) the forces shall be applied as rapidly as possible through the central vertical axis of the wheelchair space;
- (f) the force shall be maintained for a period of not less than 0.2 seconds; and
- (g) the test shall be carried out on a representative section of the vehicle structure together with any fitting provided in the vehicle which is likely to contribute to the strength or rigidity of the structure.

- (6) The forces referred to in sub-paragraph (5) are—
- (a) in the case of anchorages provided for a wheelchair restraint system fitted to a Category M₂ vehicle—
 - (i) 11100N applied in the longitudinal plane of the vehicle and towards the front of the vehicle at a height of not less than 200mm and not more than 300mm measured vertically from the floor of the wheelchair space, and
 - (ii) 5500N applied in the longitudinal plane of the vehicle and towards the rear of the vehicle at a height of not less than 200mm and not more than 300mm measured vertically from the floor of the wheelchair space;
 - (b) in the case of anchorages provided for a wheelchair restraint system fitted to a Category M₃ vehicle—
 - (i) 7400N applied in the longitudinal plane of the vehicle and towards the front of the vehicle at a height of not less than 200mm and not more than 300mm measured vertically from the floor of the wheelchair space, and
 - (ii) 3700N applied in the longitudinal plane of the vehicle and towards the rear of the vehicle at a height of not less than 200mm and not more than 300mm measured vertically from the floor of the wheelchair space;
 - (c) in the case of anchorages provided for a wheelchair user restraint system, the forces shall be in accordance with the requirements of paragraph 5.4 of Annex 1 of the 1976 Directive;

References to M₂ and M₃ vehicles are references to vehicles of those categories as defined in Annex II(A) to the 1970 Directive.

(7) A wheelchair restraint system shall be subject to a dynamic test carried out in accordance with the following requirements—

- (a) a representative wheelchair test trolley of mass 85kg shall, from a speed of between 48km/h to 50km/h to rest, be subject to a deceleration-time pulse in the forward direction which—
 - (i) exceeds 20g for a cumulative period of at least 0.015 seconds,
 - (ii) exceeds 15g for a cumulative period of at least 0.04 seconds,
 - (iii) is for an overall duration of at least 0.075 seconds and not more than 0.12 seconds,
 - (iv) shall not, for a duration of more than 0.08 seconds, be at 28g, and
 - (v) shall not exceed 28g;
- (b) except as provided in (c) below, a representative wheelchair test trolley of mass 85kg shall, from a speed of between 48km/h to 50km/h to rest, be subject to a deceleration-time pulse in the rearward direction which—
 - (i) exceeds 5g for a cumulative period of at least 0.015 seconds,
 - (ii) shall not, for a duration of more than 0.02 seconds, be at 8g, and
 - (iii) shall not exceed 8g;
- (c) the test in (b) above shall not apply if the same restraints and direction of loading are used for the forward and rearward direction or if an equivalent test has been conducted;
- (d) for the above tests the wheelchair restraint system shall be attached to either—
 - (i) anchorages fixed to the test rig which represents the geometry of the anchorages in a vehicle for which the restraint system is intended, or
 - (ii) anchorages forming part of a representative section of the vehicle for which the restraint system is intended, set up as described in sub-paragraph (5)(g).

(8) A wheelchair occupant restraint shall comply with the test requirements specified in paragraph 2.7.8.4 of Annex 1 of the 1977 Directive or an equivalent test to the deceleration-time pulse in paragraph (7)(a). A seat belt which has been type approved in accordance with the 1977 Directive, and so marked, shall be deemed to comply.

- (9) A test in sub-paragraphs (5), (7) or (8) shall fail unless the following requirements are met—
- (a) no part of the system shall have failed, or shall have become detached from its anchorage or from the vehicle during the test;
 - (b) mechanisms to release the wheelchair and user shall be capable of release after completion of the test;
 - (c) in the case of the test specified in sub-paragraph (7), the wheelchair shall not move more than 200mm in the longitudinal plane of the vehicle during the test; and
 - (d) no part of the system shall be deformed to such an extent after completion of the test that, because of sharp edges or other protrusions, the part is capable of causing injury.

Rearward-facing wheelchairs

4.—(1) Any wheelchair space fitted to a regulated public service vehicle shall comply with the following requirements—

- (a) a wheelchair space shall not be less than—

- (i) 1300mm measured in the longitudinal plane of the vehicle,
 - (ii) 750mm measured in the transverse plane of the vehicle, and
 - (iii) 1500mm measured vertically from any part of the floor of the wheelchair space;
- (b) a wheelchair space shall allow the carriage of a wheelchair and a wheelchair user seated in the wheelchair and facing the rear of the vehicle;
- (c) a wheelchair space shall be fitted with a backrest which shall—
- (i) be fitted to the front end of the wheelchair space;
 - (ii) be positioned centrally with respect to the front end of the wheelchair space, and
 - (iii) be fitted with a padded surface facing the rear of the vehicle; and
- (d) a wheelchair space shall be fitted with a horizontal handrail which shall—
- (i) be fitted along not less than one of the longitudinal sides of the wheelchair space,
 - (ii) be at a height of not less than 850mm and not more than 1000mm measured vertically from the floor of the wheelchair space,
 - (iii) run continuously from a point not more than 300mm to the rear of the front end of the wheelchair space measured horizontally to a point not less than 1000mm to the rear of the front end of the wheelchair space measured horizontally,
 - (iv) not extend into the wheelchair space by more than 90mm measured horizontally from the edge of the wheelchair space,
 - (v) be capable of being easily and firmly gripped by a wheelchair user,
 - (vi) have a circular cross section with a diameter of not less than 30mm and not more than 35mm,
 - (vii) have clear space of not less than 45mm between any part of the vehicle and all parts of a handrail other than its mountings,
 - (viii) have a slip-resistant surface, and
 - (ix) contrast with the parts of the vehicle adjacent to the handrail.
- (2) Any backrest fitted to a wheelchair space in accordance with sub-paragraph (1)(c) shall comply with the following requirements—
- (a) the bottom edge of a backrest shall be at a height of not less than 350mm and not more than 480mm measured vertically from the floor of the wheelchair space;
 - (b) the top edge of a backrest shall be at a height of not less than 1300mm measured vertically from the floor of the wheelchair space;
 - (c) a backrest shall have a width of—
 - (i) not less than 270mm and not more than 420mm up to a height of 830mm measured vertically from the floor of the wheelchair space, and
 - (ii) not less than 270mm and not more than 300mm at heights exceeding 830mm measured vertically from the floor of the wheelchair space;
 - (d) a backrest shall be fitted at an angle of not less than 4° and not more than 8° to the vertical with the bottom edge of the backrest positioned closer to the rear of the vehicle than the top edge;
 - (e) the padded surface of a backrest shall form a single and continuous plane;
 - (f) the padded surface of a backrest shall pass through any point on an imaginary vertical plane situated to the rear of the front end of the wheelchair space and situated not less than 100mm and not more than 120mm from the front end of the wheelchair space measured horizontally and not less than 830mm and not more than 870mm from the floor of the wheelchair space measured vertically; and
 - (g) a backrest shall be capable of bearing a load of 2000N applied for a minimum of 2 seconds by means of a block 200mm x 200mm square in the longitudinal plane of the vehicle towards the front of the vehicle to the centre of the padded surface of the backrest at a height of not less than 600mm and not more than 800mm measured vertically from the floor of the wheelchair space. The backrest shall not deflect more than 100mm or suffer permanent deformation or damage.
- (3) In the lateral plane of the wheelchair space, a clear space of not less than 750mm shall be maintained and, in order to restrict the lateral movement of a reference wheelchair, there shall be a distance not greater than 900mm (measured in the lateral plane of the wheelchair space) between any two of the following adjacent means of support fitted on each side of the wheelchair space—
- (a) a vertical stanchion situated to the rear of the front end of the wheelchair space and running continuously from the floor of the wheelchair space to a height of not less than 1500mm, which shall comply with the following requirements—
 - (i) the base of the stanchion shall be not less than 400mm and not more than 560mm from the front end of the wheelchair space measured horizontally, and
 - (ii) at heights exceeding 775mm measured vertically from the floor of the wheelchair space, the stanchion shall be not less than 540mm and not more than 560mm from the front end of the wheelchair space measured horizontally; or

- (b) a retractable rail extending continuously from a point not more than 200mm from the front end of the wheelchair space to a point not less than 540mm from the front end of the wheelchair space measured horizontally and at a height of not less than 600mm and not more than 800mm measured vertically from the floor of the wheelchair space; or
- (c) a partition extending continuously from a point not more than 200mm from the front end of the wheelchair space to a point not less than 540mm from the front end of the wheelchair space measured horizontally and at a height of not less than 600mm and not more than 800mm measured vertically from the floor of the wheelchair space; or
- (d) the side wall, or equipment fitted to the side wall, of the vehicle extending continuously from a point not more than 200mm from the front end of the wheelchair space to a point not less than 540mm from the front end of the wheelchair space measured horizontally and at a height of not less than 600mm and not more than 800mm measured vertically from the floor of the wheelchair space.

(4) Any stanchion, retractable rail, partition, or side wall (in this sub-paragraph referred to as “the device”) fitted to a regulated public service vehicle in accordance with sub-paragraph (3) shall be capable of bearing a load of 1000N applied for a minimum of 2 seconds by means of a block 200mm x 200mm in the transverse plane of the wheelchair space and applied to the centre of the device at a height of not less than 600mm and not more than 800mm measured vertically from the floor of the wheelchair space. The device should not deflect more than 50mm or suffer permanent deformation or damage.

(5) One or more seats which are capable of being tipped, folded or otherwise moved may lie within the volume specified in sub-paragraph (1)(a) or within the gangway specified in paragraph 7 provided that the seat is capable of being easily moved out of the volume or out of the gangway.

(6) The clear space in front of any seat may lie within the volume specified in sub-paragraph (1)(a) or within the gangway specified in paragraph 7.

(7) There shall be a sign on or near a seat specified in sub-paragraphs (5) and (6) stating the following “Please give up this seat for a wheelchair user” or stating words of equivalent meaning.

(8) In this paragraph, the phrase “front end of a wheelchair space” means the end of a wheelchair space that is closer to the front of the regulated public service vehicle to which the wheelchair space is fitted.

Boarding lifts and ramps

5.—(1) A regulated public service vehicle shall be fitted with not less than one boarding lift or one boarding ramp, or shall carry not less than one portable ramp.

- (2) Any boarding lift or boarding ramp fitted in accordance with sub-paragraph (1) shall—
 - (a) have a safe working load of not less than 300kg;
 - (b) when subject to a uniformly distributed mass equal to 125 per cent of the safe working load for a period of not less than 10 seconds, not suffer any permanent deformation or damage when the load is removed;
 - (c) have its maximum safe working load marked in a position which is clearly visible to the operator of the lift or ramp; and
 - (d) not allow the vehicle in the normal course to be driven away unless the lift or ramp is at its normal position of vehicle travel.

(3) Any boarding ramp fitted to a regulated public service vehicle shall (subject to (d) below) comply with the following requirements—

- (a) a boarding ramp shall have a surface of not less than 800mm in width;
- (b) no part of the surface in sub-paragraph (3)(a), and no part of the vehicle, shall present an obstruction greater than 15mm in height measured along a plane parallel to, and above, the surface of the ramp, and in the direction of travel of a reference wheelchair when moved into or from the vehicle;
- (c) with the vehicle on a flat surface, in the normal condition for a wheelchair user to board or alight, and with the boarding ramp extended and sitting on a kerb of 125mm in height measured vertically from and parallel to the ground, the surface of a boarding ramp shall have a slope measured over the surface referred to in sub-paragraph (3)(a) of not more than 7° measured relative to the ground;
- (d) notwithstanding (c) above, a boarding ramp may have—
 - (i) at the intersection of the surface of the kerb and the surface of the ramp described above, a slope not exceeding 15° relative to the ground over a distance of not more than 150mm (measured along the surface of the ramp and parallel to the direction of travel of a reference wheelchair when it is moved from the kerb and onto the ramp surface), and
 - (ii) at any other point a slope not exceeding 15° relative to the ground over a distance of not more than 150mm (measured along the surface of the ramp and parallel to the direction of

travel of a reference wheelchair when it is moved into the vehicle) and rising to a height of not more than 15mm (measured above and parallel to the surface of the ramp or its sections);

- (e) with the vehicle on a flat surface and in the normal condition for a wheelchair user to board or alight, the boarding ramp shall be capable of being extended to and of sitting on that surface and in this position the surface of a boarding ramp shall have a slope of not more than 20° measured over the surface referred to in sub-paragraph (3)(a);
 - (f) a boarding ramp shall be free of sharp edges or other protrusions capable of causing injury; and
 - (g) around and abutting each of the edges of a boarding ramp there shall be a band of colour of not less than 50mm in width which shall contrast with the remainder of the ramp surface.
- (4) Any boarding lift fitted to a regulated public service vehicle shall comply with the following requirements—
- (a) a boarding lift platform shall be not less than 750mm in width and not less than 1200mm in length (excluding the device specified in (b) below);
 - (b) unless a boarding lift platform is in the lowered position and resting on a surface from which a wheelchair user will board, the following shall apply—
 - (i) along any side of the lift platform from which a wheelchair user will move on to, or move from, the lift platform, a device of a height not less than 100mm measured vertically above the surface of the lift platform shall operate automatically as the lift is raised above the lowered position, except that when in the raised position for a wheelchair user to move from the lift platform to the floor of the vehicle, the device shall permit unobstructed access to the floor of the vehicle;
 - (ii) along any other side, there shall be a device or structure of a height not less than 25mm measured vertically above the surface of the lift platform; and
 - (iii) part of the vehicle structure may fulfil the requirements in (i) or (ii) above throughout the operating range of the lift provided that any gaps in the structure are unlikely to cause injury while the lift is in motion;
 - (c) the vertical operating speed of a boarding lift platform shall not exceed 0.15m/s;
 - (d) with the vehicle on a flat surface and in the normal condition for a wheelchair user to board or alight, the lift shall be capable of being lowered to and of sitting on that surface;
 - (e) where the vertical travel of the lift platform exceeds 500mm, at least one side of the lift platform shall be fitted with a handrail where—
 - (i) in the case of a handrail fitted to the lift platform, a secure horizontal handrail shall be provided at a height of not less than 650mm or more than 1100mm measured vertically from the surface of the lift platform; or
 - (ii) in the case of a handrail that does not move with the lift platform, a vertical handrail shall provide a grasping point at the same heights above the lift platform throughout the range of the vertical travel; and
 - (f) around and abutting each of the edges of a boarding lift there shall be a band of colour of not less than 50mm in width which shall contrast with the remainder of the lift surface.
- (5) Any power-operated boarding lift or power-operated boarding ramp fitted to a regulated public service vehicle shall (subject to sub-paragraphs (6) to (9))—
- (a) be capable of operation—
 - (i) by means of a control situated in the driver's cab, or
 - (ii) by means of a control situated adjacent to the lift or ramp which shall only be capable of operation by means of a master control situated in the driver's cab;
 - (b) produce an audible signal when in operation;
 - (c) be capable of being manually operated, or where the vehicle is fitted with more than one lift or ramp, not less than one lift or ramp capable of being manually operated shall be accessible to each wheelchair user;
 - (d) not be capable of operation when the vehicle is in motion;
 - (e) be fitted with a safety device which stops the movement of the ramp if the ramp is subject to a reactive force not exceeding 150N in any direction and if that motion could cause injury to a passenger; and
 - (f) be fitted with sensors capable of stopping the movement of the lift platform if it comes into contact with any thing or person whilst it is in motion and, once stopped, the lift platform must be capable of being reversed.
- (6) Sub-paragraph (5)(f) shall not apply to a power-operated boarding lift which can only be operated by a control fitted in accordance with sub-paragraph (5)(a)(ii).
- (7) As an alternative to the requirement in sub-paragraph (5)(c), a regulated public service vehicle may carry a portable ramp.

- (8) This sub-paragraph applies where—
- (a) a power-operated boarding lift is fitted to a regulated public service vehicle, and
 - (b) there are areas of that lift which are not visible to a person operating the lift.
- (9) Where sub-paragraph (8) applies—
- (a) the lift shall be fitted with a stop control which is within easy reach of any user of the lift and which is operable with the palm of the hand, and
 - (b) where the stop control is activated, the lift, once stopped, shall be capable of being reversed.
- (10) Where a portable ramp is carried in a regulated public service vehicle the ramp shall—
- (a) not easily be moved when it is in the normal position for a wheelchair user to board or alight from the vehicle and it is being so used;
 - (b) be provided with a stowage position in a position where it is readily available for use;
 - (c) be capable of being securely stowed in the stowing position so as to minimise the risk of injury to the passengers, the driver and any other crew members; and
 - (d) comply with the requirements in sub-paragraph (2)(a), (b) and (c) and (3) as if references to “boarding ramp” were references to “portable ramp”.
- (11) In this paragraph “master control” means a control which enables another control to activate the relevant system, but which is not itself alone capable of activating that system.

Entrances and exits

- 6.—(1) Any entrance or exit which is intended to provide access for a wheelchair user shall have a clear unobstructed width of not less than 800mm.
- (2) Subject to sub-paragraph (3), where an entrance or exit which is intended to provide access for a wheelchair user is fitted with a power-operated boarding lift or a power-operated boarding ramp which is not within the direct field of vision of the driver—
- (a) the entrance or exit shall be fitted with an optical device; and
 - (b) the optical device shall enable the driver to have a clear unobstructed view of the inside and outside of the door area and of the operation of the lift or ramp.
- (3) Sub-paragraph (2) shall not apply to a power-operated boarding lift or a power-operated ramp which can only be operated by a control fitted in accordance with paragraph 5(5)(a)(ii).

Gangways

7. Any gangway between a wheelchair space and an entrance or exit intended to provide access for a wheelchair user—
- (a) shall allow a reference wheelchair to be moved from an entrance to the wheelchair space and from the wheelchair space to an exit, with the wheelchair user moving in a forward facing direction, and to be moved (in either direction) from the gangway into the wheelchair space in the appropriate direction for travel;
 - (b) shall not be less than 750mm wide at any point along the gangway; and
 - (c) where a vehicle is fitted with more than one wheelchair space, the requirement in (a) above shall be met with any other wheelchair space occupied with a reference wheelchair.

Signs and markings

- 8.—(1) A regulated public service vehicle shall have a sign conforming with diagram B in Part II of this Schedule, or a sign of equivalent meaning conforming to the dimensions in that diagram, which is—
- (a) coloured white on a blue background,
 - (b) of dimensions of not less than 150mm by 150mm when fitted externally or of not less than 60mm by 60mm when fitted internally, and
 - (c) situated—
 - (i) on the exterior of the vehicle and adjacent to any entrance for a wheelchair user,
 - (ii) on the interior of the vehicle and adjacent to any exit for a wheelchair user, and
 - (iii) adjacent to any wheelchair space,
 and in a position clearly visible to a wheelchair user.
- (2) There shall be situated adjacent to a wheelchair space and in a position clearly visible to a wheelchair user—
- (a) a sign indicating the direction that the wheelchair and the wheelchair user shall face during travel, and
 - (b) appropriate safety instructions explaining the use of the wheelchair space.

(3) Where a regulated public service vehicle is fitted with a wheelchair space for a forward facing wheelchair in accordance with the requirements of paragraph 3, instructions on the use of the wheelchair restraint system and wheelchair user restraint shall be situated in a position readily visible to any person using the system.

Communication devices

9.—(1) A communication device shall be fitted to a regulated public service vehicle in the following positions—

- (a) adjacent to a wheelchair space and in a position readily useable by any person who is using the wheelchair space, and
- (b) on the exterior of the vehicle adjacent to any entrance for wheelchair access which is outside the direct view of the driver, except where that entrance is in the rear of the vehicle in which case the device shall be fitted on the rearmost part of the side face of the vehicle from which passengers will board the vehicle and at a height of not less than 850mm and not more than 1000mm measured vertically from the ground (with the vehicle at its minimum height if it is fitted with a kneeling system) to the centre of the device.

(2) Unless sub-paragraph (3) applies, any communication device fitted in accordance with sub-paragraph (1) shall comply with the following requirements—

- (a) a communication device shall be operable by the palm of the hand;
- (b) the surround of the communication device shall contrast with the device and with the surface on which the surround is mounted; and
- (c) when operated, a communication device shall activate an audible signal which enables the driver to identify that a device fitted in accordance with sub-paragraph (1) has been activated, and where fitted in accordance with sub-paragraph (1)(a), after activating an audible signal may (on being operated subsequently) provide a visual signal which is visible to the driver until the opening of at least one of the exits.

(3) Where a regulated public service vehicle is required to comply with Schedule 2, any communication device fitted in accordance with sub-paragraph (1)(a) shall comply with the following requirements—

- (a) a communication device shall be operable by the palm of the hand;
- (b) the surround of the communication device shall contrast with the device and with the surface on which the surround is mounted; and
- (c) when operated, a communication device—
 - (i) after activating an audible signal to the driver which enables the driver to identify that a device fitted in accordance with sub-paragraph (1)(a) or (b) has been activated, may (on being operated subsequently) provide a visual signal to the driver until the opening of at least one of the exits;
 - (ii) shall activate an audible signal which is audible in the passenger area; and
 - (iii) shall activate at least one illuminated stopping sign on each deck of the vehicle or, in the case of an articulated vehicle, on each section of that vehicle, which is or would be within the field of vision of the passengers seated on a majority of the seats on that deck or in that section.

(4) An illuminated stopping sign—

- (a) shall not use only capital letters; and
- (b) shall display illuminated the word “stopping” or a word or words to that effect immediately a communication device is activated and until at least one of the exits is open.

Lighting

10.—(1) Lighting shall be fitted to illuminate the interior and exterior of a regulated public service vehicle sufficient to allow a wheelchair user to board and alight from the vehicle in safety.

(2) Any lighting fitted to a regulated public service vehicle in accordance with sub-paragraph (1) shall operate only when the vehicle is at rest if its use is likely to affect adversely the driver's vision.

PART II

DIAGRAM A—WHEELCHAIR DIMENSIONS

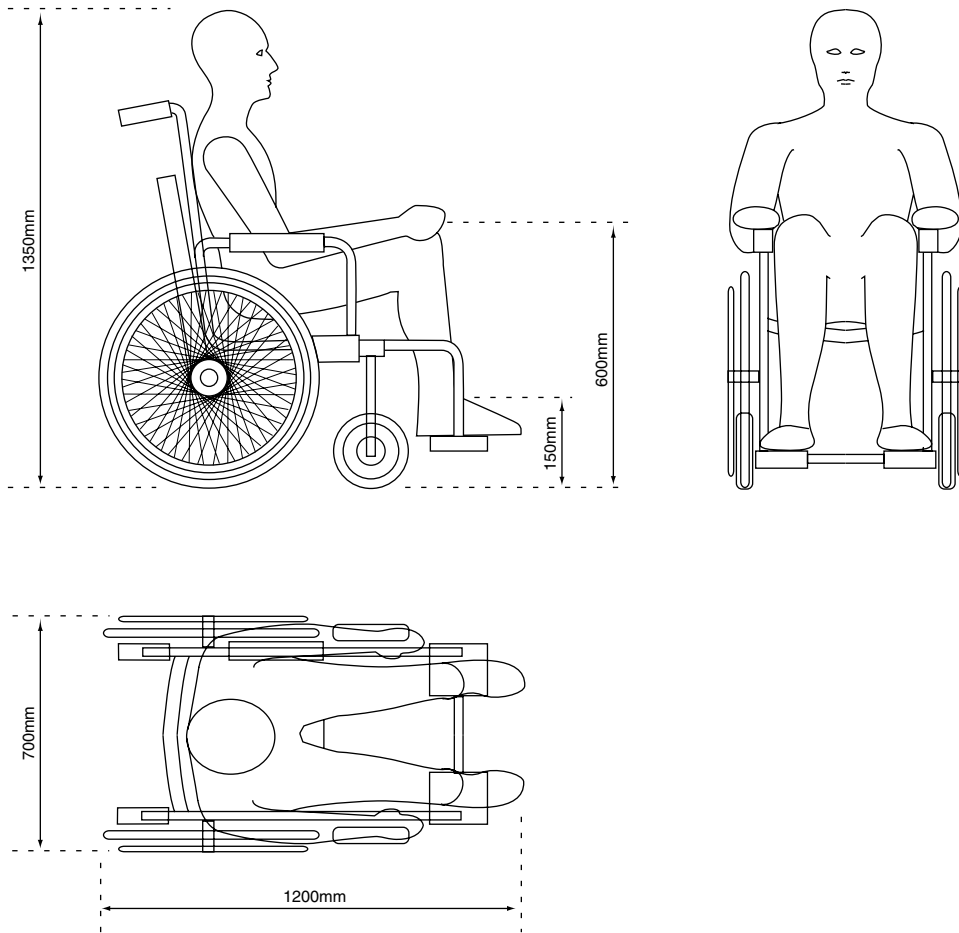
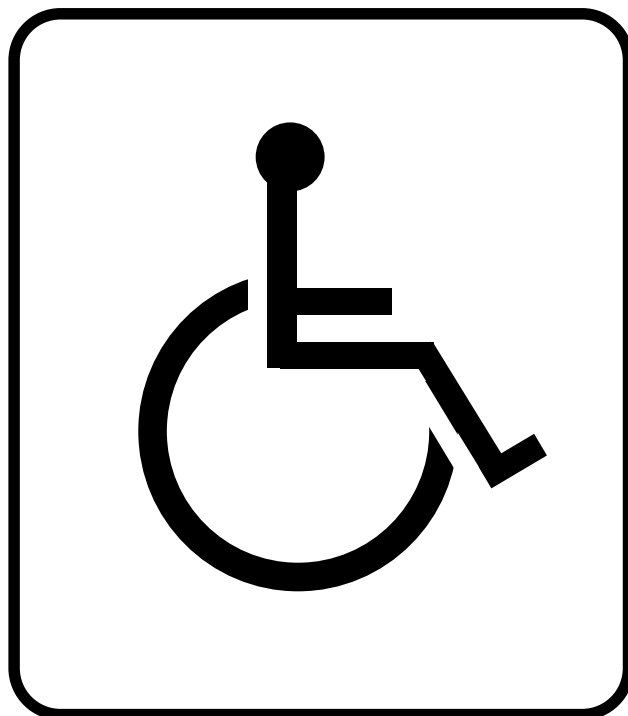

DIAGRAM B—WHEELCHAIR SIGN



SCHEDULE 2

Regulation 3

GENERAL ACCESSIBILITY REQUIREMENTS FOR SINGLE-DECK AND
DOUBLE-DECK BUSES**Definitions**

1. In this Schedule—

“contrast” means a contrast in the amount of light which is reflected by the surfaces of the parts of a regulated public service vehicle or its equipment which is required by these Regulations to contrast;

“cushion” means that part of a seat on which a person using the seat sits, whether padded or not;

“deep” in relation to a step, means the distance from the outer edge of the nosing of the step tread to the riser of the step tread;

“doorway area” means that area which is within one metre of any entrance or exit measured horizontally from any point along the external edge of the door aperture;

“exit” means an exit from a regulated public service vehicle but does not include an exit which is provided for use only in case of emergency;

“external step” means the last step or platform from an entrance or an exit which leads directly from the vehicle to the ground;

“gangway” means the space provided for obtaining access from any entrance to the passengers’ seats or from any such seat to an exit other than an emergency exit, but does not include a staircase or any space in front of a seat or row of seats which is required only for the use of passengers occupying the seat or row of seats;

“km/h” means kilometre(s) per hour;

“kneeling system” means a system which enables the bodywork of a regulated public service vehicle to be lowered relative to its normal height of travel;

“mm” means millimetre(s);

“N” means newton(s);

“normal height of travel” means the height specified by the vehicle’s manufacturer for normal vehicle travel;

“priority entrance” means an entrance (not being an entrance fitted to the off-side of the vehicle) providing access to the priority floor area in accordance with paragraph 2(2)(b);

“priority exit” means an exit (not being an exit fitted to the off-side of the vehicle) providing access from the priority floor area in accordance with paragraph 2(2)(b);

“priority floor area” means a single continuous area of floor space comprising not less than 35% of the total floor area of a regulated public service vehicle;

“priority seat” means a seat designated as such in accordance with paragraph 3;

“seat” means a seat intended for use by passengers and, accordingly, does not include the driver’s seat or any other seat intended for use solely by a crew member; and

“total floor area” means the total floor area of a regulated service vehicle, or in the case of a double-deck bus the total floor area of the vehicle’s lower deck, excluding the driver’s cab, wheelboxes, stepwells, internal staircases and any space designated for the storage of luggage.

Floor and gangways

- 2.—(1) All floors within the total floor area of a regulated public service vehicle shall be slip-resistant.
- (2) A regulated public service vehicle shall contain a priority floor area which shall—
- not contain steps;
 - provide access to at least one priority entrance to, and one priority exit from, the vehicle or access to steps which lead to such entrances and exits;
 - contain all priority seats specified in paragraph 3; and
 - have a slope of not more than 3° in any direction, or not more than 5° in any direction within the doorway area, when the vehicle is unladen standing on a level surface and in its normal condition of travel.
- (3) Any gangway within the priority floor area of a regulated public service vehicle shall have a width of—
- not less than 450mm up to a height of 1400mm measured vertically from the floor of the vehicle, and
 - not less than 550mm at heights exceeding 1400mm measured vertically from the floor of the vehicle.

Priority seats

3.—(1) A regulated public service vehicle shall have not less than 4 seats designated by signs complying with sub-paragraph (3) as priority seats for use by disabled persons.

(2) Any priority seat fitted to a regulated public service vehicle and designated in accordance with sub-paragraph (1) shall comply with the following requirements—

- (a) a priority seat shall not be a seat which is capable of being tipped, folded or otherwise moved;
- (b) a priority seat shall face only the front or the rear of the vehicle;
- (c) a priority seat shall not be a seat to which the provisions of paragraphs 3(2) and (3) or 4(5) and (6) of Schedule 1 apply;
- (d) a priority seat shall be as close as practicable to a priority entrance;
- (e) there shall be adequate space under or adjacent to at least one priority seat for the comfortable accommodation of a dog trained to assist a disabled person;
- (f) any armrest fitted to a priority seat shall be moveable to the extent required to permit unrestricted access by a disabled person to that seat or to any other priority seat to which access may be gained past the seat;
- (g) a cushion of a priority seat shall have a width of not less than 440mm measured at the widest point across the surface of the cushion, such distance being equally spaced either side of the centreline of the seating position;
- (h) the top surface of a cushion of a priority seat shall be at a height of not less than 400mm and not more than 500mm above the floor of the vehicle measured from the front edge of the seat and along an imaginary line passing vertically from the centreline of the seating position to the floor;
- (i) where a priority seat faces the same direction as a seat situated directly in front of the priority seat—
 - (i) the distance between the front surface of the back of the priority seat and the back surface of the back of the seat in front (measured along an imaginary horizontal line passing along the top surface of the cushion of the priority seat and through the centreline of the seating position of the priority seat) shall not be less than 650mm, and
 - (ii) where the back of either seat is adjustable, this measurement shall be made with the seat or seats in the manufacturer's nominal position for normal use;
- (j) where a priority seat faces any other seat—
 - (i) the distance between the front surface of the back of the priority seat and the front surface of the back of the facing seat (measured along an imaginary horizontal line passing along the top surface of the cushion of the priority seat and through the centreline of the seating position of the priority seat) shall not be less than 1300mm, and
 - (ii) where the back of either seat is adjustable, this measurement shall be made with the seat or seats in the manufacturer's nominal position for normal use;
- (k) there shall be—
 - (i) not less than 1300mm of clear space above any point along the front edge of the top surface of a cushion of a priority seat measured vertically from the top surface of the cushion,
 - (ii) not less than 900mm of clear space above any point along the rear edge of the top surface of a cushion of a priority seat measured vertically from the top surface of the cushion, and
 - (iii) clear space between any point on the top surface of a cushion of a priority seat and an imaginary plane connecting the maximum height of clear space specified in (i) above to the maximum height of clear space specified in (ii) above; and
- (l) where a priority seat faces the same direction as a seat situated directly in front of the priority seat or if the priority seat faces a bulkhead or a partition, there shall be—
 - (i) above an imaginary horizontal plane passing along the top surface of a cushion of a priority seat and situated in front of the front edge of the cushion, a volume of clear space of not less than 230mm measured in the longitudinal plane of the priority seat, of not less than 420mm measured in the transverse plane of the priority seat (such distance being equally spaced either side of the centreline of the seating position) and of a height not less than the height of the back of the priority seat;
 - (ii) below an imaginary horizontal plane passing along the top surface of a cushion of a priority seat and situated in front of the front edge of the cushion, a volume of clear space of not less than 230mm measured in the longitudinal plane of the priority seat, of not less than 300mm measured in the transverse plane of the priority seat (such distance being equally spaced either side of the centreline of the seating position) and of a height not less than the height of the priority seat cushion, and

- (iii) where a priority seat is situated facing a bulkhead or a partition which is more than 1200mm in height measured vertically from the floor of the vehicle, the distances measured in the longitudinal plane of the priority seat referred to in (i) and (ii) above shall not be less than 300mm.

(3) There shall be a sign on or near a priority seat indicating that disabled persons have priority for the use of that seat.

(4) In sub-paragraph (2) the phrase “manufacturer’s nominal position for normal use” means the position of an adjustable seat which the manufacturer of the seat recommends, or has nominated, as being the normal position for using that seat.

Steps

4.—(1) Steps for use by passengers on a regulated public service vehicle shall (subject to sub-paragraph (6)) comply with the following requirements—

- (a) the surface of each tread shall be covered in a slip-resistant material;
- (b) step nosings shall be designed to minimise the risk of tripping;
- (c) across the front edge of each tread there shall be a band of colour not less than 45mm and not more than 50mm in width, which shall contrast with the remainder of the tread;
- (d) the rear of a step shall be closed by a vertical riser between the rear of the tread and either the front edge of the tread above or the floor of the vehicle above;
- (e) any step, other than an external step or a step to a seat fitted to any part of a wheelarch or a step in (f) below, shall—
 - (i) not be less than 120mm and not more than 200mm in height, and
 - (ii) the surface of the tread shall not be less than 300mm deep and not less than 400mm wide;
- (f) any steps between a gangway and a passenger seat or a row of passenger seats, other than a step to any seat fitted to any part of a wheelarch, shall not be more than 250mm in height; and
- (g) in a flight of steps, the difference in height between any two steps shall not be more than 10mm.

(2) The height of a step in sub-paragraph (1) shall be measured vertically from the surface of the tread, and at the centre of the tread width, to an imaginary line extended horizontally from the surface of the next tread or floor of the vehicle.

(3) An external step, leading from not less than one priority entrance and to not less than one priority exit, shall—

- (a) not be more than 250mm in height measured—
 - (i) from the surface of the tread of the external step to the ground,
 - (ii) if the vehicle is fitted with a kneeling system, with the regulated public service vehicle at its minimum height, and
 - (iii) at the centre of the tread width; and
- (b) not be less than 300mm deep.

(4) A regulated public service vehicle shall not be fitted with a step which can project beyond the side of the vehicle adjacent to the step unless—

- (a) the step is protected by parts of the vehicle or otherwise so that it is not liable to injure pedestrians; or
- (b) the step can fold or retract so that it does not project beyond the side face of the vehicle and the vehicle is not capable in the normal course of being driven away unless the step is so folded or retracted.

(5) Where a regulated public service vehicle is fitted with a power-operated step, that step shall—

- (a) not be capable of operation whilst the vehicle is in motion, and
- (b) be fitted with a safety device which stops the motion of the step if the step is subject to a reactive force not exceeding 150N in any direction and if that motion could cause injury to a passenger.

(6) Sub-paragraphs (1)(d), (e) and (g) shall not apply to those steps in a double-deck bus which lead from the lower deck to the upper deck.

Handrails and handholds

5.—(1) A handrail shall (subject to sub-paragraph (2)) be fitted in the following positions in a regulated public service vehicle—

- (a) along one or both sides of a gangway—
 - (i) from a position level with the top of the back of a seat extending to the ceiling of the vehicle, or to a height of not less than 1500mm measured vertically from the floor of the vehicle, at intervals of not more than 1050mm measured in the longitudinal direction of the vehicle, or
 - (ii) in areas where there are no seats adjacent to a gangway, from the floor to the ceiling, or to

a height of not less than 1500mm measured vertically from the floor of the vehicle, at intervals of not more than 1050mm measured in the longitudinal direction of the vehicle, and

- (iii) where the gangway is adjacent to the internal walls of the vehicle, horizontally along the internal wall of the vehicle and parallel to those walls at a height of not less than 1200mm and not more than 1500mm measured vertically from the floor of the vehicle;
- (b) in any area where passengers may stand other than a gangway—
 - (i) where the area is adjacent to the internal walls of the vehicle, horizontally along the internal walls of the vehicle and parallel to those walls at a height of not less than 1200mm and not more than 1500mm measured vertically from the floor of the vehicle, and
 - (ii) in any other area, from the floor to the ceiling, or to a height of not less than 1500mm measured vertically from the floor of the vehicle, at intervals of not more than 1050mm measured in the longitudinal direction of the vehicle;
- (c) from the doorway area immediately adjacent to a priority entrance to not less than one of the priority seats at a height of not less than 800mm and not more than 900mm measured vertically from the floor of the vehicle or, where it is not practical to comply with those requirements, the handrail need not be continuous provided any gap does not exceed 1050mm and a vertical handrail is provided on at least one side of the gap extending from a height of at least 1200mm to a height of not less than 1500mm measured vertically from the floor of the vehicle; and
- (d) on both sides of the interior of an entrance or exit—
 - (i) in the case of any external step in the vehicle entrance which is fixed, not more than 400mm measured from the outer edge of the step nosing and at a height of not less than 800mm and not more than 1100mm measured vertically from the ground, with the vehicle at its minimum height if the vehicle is fitted with a kneeling system,
 - (ii) in the case of an external step in the vehicle entrance which is not fixed, on both sides of the interior of an entrance or exit not more than 100mm from the outer edge of the step nosing of the lowest fixed step in the vehicle entrance and at a height of not less than 800mm and not more than 1100mm measured as mentioned in (i) above, and
 - (iii) in the case of any other steps leading into a vehicle, for the position appropriate to a particular step, at not more than 600mm measured horizontally and inwards from the outer edge of the step nosing of the tread of a step or the floor of the vehicle and at a height of not less than 800mm and not more than 1100mm measured vertically from the surface of the tread of the step.

(2) Where—

- (a) it is necessary to provide access to and into a wheelchair space, and
- (b) it is not possible to comply with the requirements of sub-paragraph (1)(b) or (1)(c),

a horizontal handrail or, at intervals of not more than 300mm, a series of handholds shall be provided across the gap.

(3) Any handrail in a regulated public service vehicle that is fitted in order to comply with this paragraph shall comply with the following requirements—

- (a) have a circular cross section with a diameter of not less than 30mm and not more than 35mm, or when fitted at either side of an entrance or exit, an oval cross section the maximum section of which is not more than 35mm and not less than 30mm, and the minimum section of which is not less than 20mm;
- (b) not be less than 800mm or more than 1900mm above the floor of the vehicle;
- (c) have a clear space of not less than 45mm between any part of the vehicle and all parts of a handrail other than its mountings;
- (d) have a slip-resistant surface;
- (e) be capable of being easily and firmly gripped by a passenger; and
- (f) contrast with the parts of the vehicle adjacent to the handrail.

(4) Any handhold in a regulated public service vehicle that is fitted in order to comply with this paragraph shall comply with the following requirements—

- (a) not be less than 800mm or more than 1900mm above the floor of the vehicle;
- (b) have a clear space of not less than 45mm between any part of the vehicle and all parts of a handhold other than its mountings;
- (c) have a loop shape, or some other form, designed to prevent a hand from slipping from the handhold;
- (d) have a slip-resistant surface;
- (e) be capable of being easily and firmly gripped by a passenger; and
- (f) contrast with the parts of the vehicle adjacent to the handhold.

- (5) A handhold may be placed within the space of a gangway provided—
- (a) it is unlikely to cause injury; and
 - (b) it is easily moveable to the extent required to permit unrestricted access by a disabled person to a priority seat or to the gangway.

Communication devices

6.—(1) A communication device shall be fitted in the following positions in a regulated public service vehicle—

- (a) within reach of each person seated in a priority seat;
 - (b) adjacent to not less than every third row of seats; and
 - (c) at a height of—
 - (i) not more than 1200mm if the communication device is for the use of seated passengers, or
 - (ii) not more than 1500mm if the communication device is for the use of other passengers, measured vertically from the floor of the vehicle to the centre of the device.
- (2) Any communication device shall comply with the following requirements—
- (a) a communication device shall be operable by the palm of the hand;
 - (b) the surround of the communication device shall contrast with the device and with the surface on which the surround is mounted; and
 - (c) when operated, a communication device shall—
 - (i) provide a signal to the driver of the vehicle to stop the vehicle,
 - (ii) activate an audible signal which is audible in the passenger areas, and
 - (iii) activate at least one illuminated stopping sign on each deck of the vehicle or, in the case of an articulated vehicle, on each section of that vehicle, which is, or would be, within the field of vision of the passengers seated on a majority of the seats on that deck or in that section, and
- (3) An illuminated stopping sign—
- (a) shall not use only capital letters; and
 - (b) shall display illuminated the word “stopping” or a word or words to that effect immediately a communication device is activated and until at least one of the exits is open.

Kneeling Systems

7.—(1) Where a regulated public service vehicle is fitted with a kneeling system, the vehicle and system shall comply with the following requirements—

- (a) a switch shall be required to be used to enable operation of the system;
- (b) any control which initiates the lowering or raising of any part or the whole of the body relative to the road surface must be clearly identified and under the direct control of the driver of the vehicle;
- (c) the lowering process shall be capable of being stopped and immediately reversed by a control which is both—
 - (i) within reach of the driver whilst seated in the cab, and
 - (ii) adjacent to any controls provided for the operation of the kneeling system; and
- (d) the kneeling system shall not—
 - (i) allow the vehicle to be driven at a speed of more than 5km/h where the vehicle is lower than the normal height of travel, or
 - (ii) allow the vehicle to be lowered when the operation of an entrance or exit door (other than an emergency door) is prevented for any reason.

(2) In this paragraph “emergency door” means an external door which is generally intended for use only in an emergency.

Route and destination displays

8.—(1) A regulated public service vehicle shall be fitted with a route number display and a destination display in the following positions—

- (a) on the front of the vehicle, as close as practicable to that part of the windscreen which is within the driver’s field of vision; and

- (b) on the nearside of the vehicle adjacent to the entrance which is closest to the front of the vehicle at a height of not less than 1.2m to the lower edge of the display characters and not more than 2.5m to the upper edge of the display characters measured from the ground and, if fitted with a kneeling system, with the vehicle in the normal condition for vehicle travel.
- (2) A regulated public service vehicle shall be fitted with a route number display on the rear of the vehicle.
- (3) Any route number display shall be capable of displaying—
- (a) characters of not less than 200mm in height on the front and rear of the vehicle and not less than 70mm in height on the side of the vehicle;
 - (b) characters that contrast with the display background;
 - (c) characters that are provided with a means of illumination; and
 - (d) not less than three characters.
- (4) Any destination display shall be capable of displaying—
- (a) characters of not less than 125mm in height when fitted to the front of a vehicle and not less than 70mm in height when fitted to the side of a vehicle;
 - (b) characters that contrast with the display background;
 - (c) characters that are provided with a means of illumination; and
 - (d) not less than fifteen characters.
- (5) Destination information shall not be written in capital letters only.
- (6) In this paragraph—
- “character” means capital letters or numbers of a specified height and lower case letters of a size relative to the text of a capital letter for a given typeface;
- “destination” means a word or words to describe the route or final destination; and
- “route number” means any combination of numbers or letters which designate a bus route.

SCHEDULE 3

Regulation 3

GENERAL ACCESSIBILITY REQUIREMENTS FOR SINGLE-DECK AND DOUBLE-DECK COACHES

Definitions

1. In this Schedule—

“contrast” means a contrast in the amount of light which is reflected by the surfaces of the parts of a regulated public service vehicle or its equipment which are required by these Regulations to contrast;

“cushion” means that part of a seat on which a person using the seat sits, whether padded or not;

“deep” in relation to a step, means the distance from the outer edge of the nosing of the step tread to the riser of the step tread;

“exit” means an exit from a regulated public service vehicle but does not include an exit which is provided for use only in case of emergency;

“external step” means the last step or platform from an entrance or an exit which leads directly from the vehicle to the ground;

“gangway” means the space provided for obtaining access from any entrance to the passengers’ seats or from any such seat to an exit other than an emergency exit, but does not include a staircase or any space in front of a seat or row of seats which is required only for the use of passengers occupying the seat or row of seats;

“km/h” means kilometer(s) per hour;

“kneeling system” means a system which enables the bodywork of a regulated public service vehicle to be lowered relative to its normal height of travel;

“mm” means millimetre(s);

“N” means newton(s);

“normal height of travel” means the height specified by the vehicle’s manufacturer for normal vehicle travel; and

“seat” means a seat intended for use by passengers and, accordingly, does not include the driver’s seat or any other seat intended for use solely by a crew member.

Floors and gangways

2.—(1) All floors within a regulated public service vehicle shall be slip-resistant.

(2) Any gangway within a regulated public service vehicle shall have a slope of not more than 5° in any direction, when the vehicle is unladen standing on a level surface and in its normal condition of travel.

Seats

3.—(1) Any seat fitted to a regulated public service vehicle shall comply with the following requirements—

- (a) the top surface of a cushion of a seat shall be at a height of not less than 400mm and not more than 500mm above the floor of the vehicle measured from the front edge of the seat and along an imaginary line passing vertically from the centreline of the seating position to the floor;
- (b) any armrest fitted to a seat shall be moveable to the extent required to permit unrestricted access by a disabled person to that seat or to any other seat to which access may be gained past that seat;
- (c) where a seat (referred to below as “the first seat”) faces the same direction as another seat situated directly in front of the first seat—
 - (i) the distance between the front surface of the back of the first seat and the back surface of the back of the seat in front (measured along an imaginary horizontal line passing along the top surface of the cushion of the first seat and through the centreline of the seating position of the first seat) shall not be less than 650mm, and
 - (ii) where the back of either seat is adjustable, this measurement shall be made with the seat or seats in the manufacturer’s nominal position for normal use;
- (d) where a seat faces a bulkhead or a partition—
 - (i) the distance between the front surface of the back of the seat and the bulkhead or partition (measured along an imaginary horizontal line passing along the top surface of the cushion of the seat and through the centreline of the seating position of the seat) shall not be less than 650mm, and
 - (ii) where the back of the seat is adjustable, this measurement shall be made with the seat or seats in the manufacturer’s nominal position for normal use; and
- (e) where a seat (referred to below as “the first seat”) faces either the front or the rear of the vehicle and where the seat also faces any other seat—
 - (i) the distance between the front surface of the back of the first seat and the front surface of the back of the facing seat (measured along an imaginary horizontal line passing along the top surface of the cushion of the first seat and through the centreline of the seating position of the first seat) shall not be less than 1300mm, and
 - (ii) where the back of either seat is adjustable, this measurement shall be made with the seats or seats in the manufacturer’s nominal position for normal use.

(2) In this paragraph, “manufacturer’s nominal position for normal use” means the position of an adjustable seat which the manufacturer of the seat recommends, or has nominated, as being the normal position for using the seat.

Steps

4.—(1) Steps for use by passengers on a regulated public service vehicle shall, except as provided in sub-paragraph (4), comply with the following requirements—

- (a) the surface of each tread shall be covered in a slip-resistant material;
- (b) step nosings shall be designed to minimise the risk of tripping;
- (c) across the front edge of each tread there shall be a band of colour not less than 45mm and not more than 50mm in width, which shall contrast with the remainder of the tread;
- (d) any steps, other than an external step, in any part of a gangway or staircase between every passenger seat and an entrance or exit complying with sub-paragraph (5) shall—
 - (i) not be less than 120mm and not more than 225mm in height, and
 - (ii) the surface of a tread shall not be less than 250mm deep;
- (e) any steps between a gangway and a passenger seat or a row of passenger seats shall not be more than 250mm in height; and
- (f) in a flight of steps, the difference in height between any two steps shall not be more than 10mm.

(2) The height of a step in sub-paragraph (1) shall be measured vertically from the surface of the tread, and at the centre of the tread width, to an imaginary line extended horizontally from the surface of the next tread or floor of the vehicle.

(3) Where one flight of steps connects with another, there shall be an area of floor at the point where the two flights connect, on which it is possible to inscribe a circle of a diameter of not less than 450mm.

(4) Where—

- (a) a regulated public service vehicle is a double-deck coach, and
- (b) that vehicle has, for the use of passengers, more than one means of access from the lower deck to the upper deck,

the requirements of sub-paragraphs (1)(d) and (3) shall only apply to one of those means of access if that means of access can be used for both access to and from the upper deck and it provides access to an entrance and exit which complies with sub-paragraph (5). In this sub-paragraph “means of access from the lower deck to the upper deck” means a flight of steps, or two or more connecting flights of steps, which lead from the lower deck to the upper deck of a double-deck coach.

(5) An external step leading from not less than one entrance and to not less than one exit, not being an entrance or exit on the off-side of the vehicle shall—

- (a) not be more than 320mm in height measured—
 - (i) from the surface of the tread of the external step to the ground;
 - (ii) if the vehicle is fitted with a kneeling system, with the regulated public service vehicle at its minimum height; and
 - (iii) at the centre of the tread width; and
- (b) not be less than 250mm deep.

(6) A regulated public service vehicle shall not be fitted with a step which can project beyond the side of the vehicle adjacent to the step unless—

- (a) the step is protected by parts of the vehicle or otherwise so that it is not liable to injure pedestrians; or
- (b) the step can fold or retract so that it does not project beyond the side face of the vehicle and the vehicle is not capable in the normal course of being driven away unless the step is so folded or retracted.

(7) Where a regulated public service vehicle is fitted with a power-operated step, that step shall—

- (a) not be capable of operation whilst the vehicle is in motion, and
- (b) be fitted with a safety device which stops the motion of the step if the step is subject to a reactive force not exceeding 150N in any direction and if that motion could cause injury to a passenger.

Handrails

5.—(1) A handrail shall (subject to sub-paragraph (2)) be fitted in the following positions in a regulated public service vehicle—

- (a) on both sides of the interior of an entrance or exit (not being an entrance or exit on the off-side of the vehicle):
 - (i) not more than 100mm inwards (measured from the outer edge of the step nosing of any fixed external step leading into a vehicle entrance, or, if that step is not a fixed step, from the outer edge of the lowest fixed step in that entrance) and at a height of not less than 800mm and not more than 1100mm measured vertically from the ground, with the vehicle at its minimum height if the vehicle is fitted with a kneeling system, and
 - (ii) in the case of any other steps leading into a vehicle, for the position appropriate to a particular step, at not more than 600mm (measured horizontally and inwards from the outer edge of the step nosing of the tread of a step or the floor of the vehicle) and at a height of not less than 800mm and not more than 1100mm measured vertically from the surface of the tread of the step; and
- (b) in any gangway, above each step for use by passengers—
 - (i) not more than 600mm measured horizontally and inwards from the outer edge of the step nosing of the tread of a step or the floor of the vehicle, and
 - (ii) above this point at a height of not less than 800mm and not more than 1100mm measured vertically from the surface of the tread of the step.

(2) Where it is not practicable to comply with the requirements of sub-paragraph (1)(a) on both sides of an entrance, a vehicle may, as an alternative to such requirements as they apply to one side of that entrance, be fitted with a vertical handrail in the following location—

- (a) not more than 100mm measured inwards from the outer edge of the step nosing of any external step or, if an external step is not a fixed step, of the lowest fixed step in the vehicle entrance, and
- (b) extending vertically from a height of not more than 800mm to a height of not less than 2000mm or, where this is not practicable due to the vehicle structure or ceiling, to the highest height that can be achieved, measured vertically from the ground with the vehicle at its minimum height if the vehicle is fitted with a kneeling system.

(3) Any handrail in a regulated public service vehicle that is fitted in order to comply with this paragraph shall comply with the following requirements—

- (a) have a circular cross section with a diameter of not less than 30mm and not more than 35mm,

- or when fitted at either side of an entrance or exit, an oval cross section the maximum section of which is not more than 35mm and not less than 30mm, and the minimum section of which is not less than 20mm;
- (b) with the exclusion of a handrail fitted in accordance with sub-paragraph (2), be not less than 800mm or more than 1900mm above the floor of the vehicle;
 - (c) have a clear space of not less than 45mm between any part of the vehicle and all parts of a handrail other than its mountings;
 - (d) have a slip-resistant surface;
 - (e) be capable of being easily and firmly gripped by a passenger; and
 - (f) contrast with the parts of the vehicle adjacent to the handrail.

Kneeling Systems

6.—(1) Where a regulated public service vehicle is fitted with a kneeling system, the vehicle and system shall comply with the following requirements—

- (a) a switch shall be required to be used to enable operation of the system;
- (b) any control which initiates the lowering or raising of any part or the whole of the body relative to the road surface must be clearly identified and under the direct control of the driver of the vehicle;
- (c) the lowering process shall be capable of being stopped and immediately reversed by a control which is both—
 - (i) within reach of the driver whilst seated in the cab; and
 - (ii) adjacent to any controls provided for the operation of the kneeling system;
- (d) the kneeling system shall not—
 - (i) allow the vehicle to be driven at a speed of more than 5km/h where the vehicle is lower than the normal height of travel, or
 - (ii) allow the vehicle to be lowered when the operation of an entrance or exit door (other than an emergency door) is prevented for any reason.

(2) In this paragraph “emergency door” means an external door which is generally intended for use only in an emergency.

Route and destination displays

7.—(1) A regulated public service vehicle shall be fitted with a route number display and a destination display in the following positions—

- (a) on the front of the vehicle, as close as practicable to the part of the windscreen which is within the driver’s field of vision; and
- (b) on the near-side of the vehicle adjacent to the entrance which is closest to the front of the vehicle at a height of not less than 1.2 metres to the lower edge of the display characters and not more than 2.5 metres to the upper edge of the display characters measured from the ground and, if fitted with a kneeling system, with the vehicle in the normal condition for vehicle travel.

(2) A regulated public service vehicle shall be fitted with a route number display on the rear of the vehicle.

- (3) Any route number display shall be capable of displaying—
 - (a) characters of not less than 200mm in height on the front and rear of the vehicle and not less than 70mm in height on the side of the vehicle;
 - (b) characters that contrast with the display background;
 - (c) characters that are provided with a means of illumination; and
 - (d) not less than three characters.
- (4) Any destination display shall be capable of displaying—
 - (a) characters of not less than 125mm in height when fitted to the front of a vehicle and not less than 70mm in height when fitted to the side of a vehicle;
 - (b) characters that contrast with the display background;
 - (c) characters that are provided with a means of illumination; and
 - (d) not less than fifteen characters.

(5) Destination information shall not be written in capital letters only.

(6) In this paragraph—

“character” means capital letters or numbers of a specified height and lower case letters of a size relative to that of a capital letter for a given typeface;

“destination” means a word or words to describe the route or final destination; and

“route number” means any combination of numbers or letters which designate a coach route.

SCHEDULE 4

Regulation 8

ACCESSIBILITY CERTIFICATE

ACCESSIBILITY CERTIFICATE

Department of the Environment, Transport and the Regions

DISABILITY DISCRIMINATION ACT 1995

Certificate No

I, the undersigned, a Vehicle Examiner duly appointed by the Secretary of State, hereby certify, in accordance with the provisions of the Disability Discrimination Act 1995, that the vehicle described below conforms to Schedule(s) to the Public Service Vehicles Accessibility Regulations 2000 made under the Disability Discrimination Act 1995.

Description of vehicle

Registration mark (if any):

Chassis (VIN) Number:

Date of manufacture or first use:

Chassis make: model:

Body make: model:

Vehicle Examiner

Signed

Print name..... date

SCHEDULE 5

Regulation 14

DECLARATION OF CONFORMITY TO AN APPROVED TYPE VEHICLE

DECLARATION OF CONFORMITY TO AN APPROVED TYPE VEHICLE

Department of the Environment, Transport and the Regions

DISABILITY DISCRIMINATION ACT 1995

Description of vehicle

Registration mark (if any):

Chassis (VIN) Number:

Date of manufacture or first use:

Chassis make: model:

Body make: model:

I, the undersigned, being a person duly authorised in this behalf by the body manufacturer/convertor of the vehicle described above, hereby declare that the vehicle conforms in design, construction and equipment with the type vehicle to which Type Vehicle Approval number was granted by the Secretary of State on..... as that type vehicle satisfied the requirement of Schedule(s)..... to the Public Service Vehicles Accessibility Regulations 2000 made under the Disability Discrimination Act 1995.

Signed

(for and on behalf of the vehicle body manufacturer/convertor)

Print name..... date

SCHEDULE 6
CONFORMITY CERTIFICATE

Regulation 16

CONFORMITY CERTIFICATE

Department of the Environment, Transport and the Regions

DISABILITY DISCRIMINATION ACT 1995

Certificate No

I, the undersigned, a Vehicle Examiner duly appointed by the Secretary of State, hereby certify, in accordance with the provisions of the Disability Discrimination Act 1995, that the vehicle described below conforms to the type vehicle to which Type Vehicle Approval number was granted by the Secretary of State on..... as that type vehicle satisfied the requirements of Schedule(s)..... to the Public Service Vehicles Accessibility Regulations 2000 made under the Disability Discrimination Act 1995.

Description of vehicle

Registration mark (if any):.....

Chassis (VIN) Number:.....

Date of manufacture or first use:.....

Chassis make:..... model:

Body make:..... model:

Vehicle Examiner

Signed

Print name.....

Date.....

EXPLANATORY NOTE

(This note is not part of the Regulations)

These Regulations apply to single-deck and double-deck buses and to single-deck and double-deck coaches with a capacity of more than twenty-two passengers which are used to provide local and scheduled services (“regulated public service vehicles”). The Regulations, which are enacted under the Disability Discrimination Act 1995, are intended to ensure that disabled people can get on and off a regulated public service vehicle in safety and without unreasonable difficulty and, in the case of wheelchair users, can do so whilst remaining in their wheelchairs. They are also intended to ensure that disabled people are carried in these vehicles in safety and reasonable comfort. The Regulations recognise the impact on the bus industry, to both manufacturers and operators, which their provisions will have, particularly with respect to accessibility to smaller buses and high floor coaches, by providing for a phased implementation of their requirements.

The principal features are as follows.

1. The detailed technical requirements to be met by regulated public service vehicles are contained in three schedules. *Schedule 1* sets out the wheelchair accessibility requirements and *Schedules 2 and 3* deal with the general accessibility requirements for buses and coaches respectively. Among these requirements are provisions in *Schedule 1* for the benefit of passengers in wheelchairs dealing with such matters as wheelchair spaces (paragraph 2), boarding lifts and ramps (paragraph 5), entrances and exits (paragraph 6), gangways (paragraph 7), communication devices (paragraph 9) and lighting (paragraph 10) and in *Schedules 2 and 3* for such additional matters as steps (paragraph 4), handrails (paragraph 5) and kneeling systems (paragraphs 7 and 6 respectively).

2. *Regulation 3* applies the requirements of these Schedules to the various types of public service vehicle according to the date when they are first used. New buses weighing more than 7.5 tonnes and new double-deck buses must comply with both *Schedules 1 and 2* from 31 December 2000 and all such buses which are in use must meet these requirements after 2016 and 2017. New buses weighing 7.5 tonnes or less and new coaches must from 31 December 2000 comply with *Schedules 2 or 3* respectively until 1 January 2005, after which new vehicles of these kinds must also comply with *Schedule 1*. All these regulated public service vehicles must meet the wheelchair accessibility requirements and those of the appropriate general accessibility requirements if in use after 1 January 2015 (for buses weighing 7.5 tonnes or less) or 2020 (for coaches). There is an exception in the case of regulated public service vehicles that are manufactured before 1 October 2000 and 1 October 2004; they are not required to comply with the requirements of the relevant Schedules unless and until they are in use on or after 1 January in either 2015 or 2016 or 2017 or 2020 as appropriate.

3. *Regulation 4* exempts certain vehicles from the Regulations as well as providing for a delay until 1 January 2003 in the application of two requirements, in *Schedule 1* (boarding ramps) and in *Schedule 3* (illumination of side route and destination displays).

4. *Regulations 6 to 8* (Part III) contains provisions relating to the issue of accessibility certificates and *regulations 9 to 12* (Part IV) set out provisions with respect to the obtaining of a type vehicle approval. *Regulations 13 and 14* (Part V) deal with declarations of conformity to a type vehicle and in *regulations 15 to 17* (Part VI) are set out the provisions relating to conformity certificates.

5. *Regulations 18 and 19* (Part VII) deal with the issue of duplicate documentation and with reviews and appeals.

6. *Schedules 4 to 6* set out the information to be contained in the accessibility certificate and the form of the declaration of conformity and the conformity certificate.

A Regulatory Impact Assessment of the costs and benefits of the making of these Regulations has been prepared and copies can be obtained from the Department of the Environment, Transport and the Regions, Zone 1/18, Great Minster House, 76 Marsham Street, London SW1P 4DR (telephone 020 7944 4914). A copy has been placed in the library of each House of Parliament.