



NATIONAL ASSEMBLY FOR WALES

---

STATUTORY INSTRUMENTS

---

**2005 No. 3038 (W.226)**

**SEEDS, WALES**

The Seed (Registration, Licensing and Enforcement) (Wales) Regulations  
2005

*Made*

*1 November 2005*

*Coming into force*

*18 November 2005*

**£7.50**





## NATIONAL ASSEMBLY FOR WALES

---

### STATUTORY INSTRUMENTS

---

## 2005 No. 3038 (W.226)

### SEEDS, WALES

## The Seed (Registration, Licensing and Enforcement) (Wales) Regulations 2005

### EXPLANATORY NOTE

*(This note is not part of the Regulations)*

These Regulations, which apply to Wales, revoke and replace the Seeds (Registration in relation to Licensing and Enforcement) Regulations 1985 (S.I. 1985/980) (the 1985 Regulations) as amended as respects Wales; and the Seeds (Fees) Regulations 1985 (the 1985 Fees Regulations) as amended in relation to matters arising under the 1985 Regulations as respects Wales. These Regulations come into force on 18 November 2005.

The Regulations continue to prohibit a person from engaging in the seed industry (now defined in relation to a "seed industry activity" in regulation 2) unless the person has been registered by the National Assembly (regulation 3). New provision is made to request the termination of registrations (regulation 7). Breach of the conditions of registration may lead to revocation (regulation 8).

There is continued provision to license crop inspectors (regulation 11). New provision is made for a crop inspector to apply to the National Assembly to have his or her licence varied (regulation 12(1)) or terminated (regulation 13) and the National Assembly continues to be able to vary the licence in any event (regulation 12(4)). The National Assembly has power to suspend or revoke the licence (regulation 14).

The Regulations continue arrangements to license seed samplers (regulation 18). The power of the National Assembly to vary the licence continues (regulation 19) and new provision is made for the licensee to apply to the National Assembly for the termination of his or her licence (regulation 20). The National Assembly has power to suspend or revoke the licence (regulation 21).

There is continued provision to license seed testing stations (LSTSs) (regulation 25). The person in charge may now apply to vary the licence (regulation 26(1)) and the National Assembly continues to be able to vary it in any event (regulation 26(4)). The licence may now be suspended or revoked not only for breach of conditions of the licence but also if any seed analyst or the Analyst in Charge of the LSTS is unfit (regulation 29).

There is new provision to keep a list of registered persons (regulation 9), a list of licensed crop inspectors (regulation 15), a list of licensed seed samplers (regulation 22) and a list of LSTSs (regulation 30).

Provision is continued from the 1985 Regulations for fees to be charged for the services provided by crop inspectors (regulation 16), seed samplers (regulation 23) and LSTSs (regulation 31). In addition, fees which were prescribed under the 1985 fees Regulations are now included in these Regulations, namely fees for the licensing, supervision and operation of LSTSs (regulation 31(2)), for examination fees for crop inspectors and seed samplers (regulation 35) and for making representations (regulation 36(10)).

Provision for enforcement of seeds regulations is also continued and requirements relating to sampling are now set out in these regulations (regulation 32).

New arrangements are made for any person to act under the responsibility of the National Assembly in carrying out official measures (regulation 34) and for fees to be charged in that connection (regulation 35).

The right to make representations is expanded to cover the categories set out in regulation 36(1). The National Assembly will not proceed with a refusal, variation, suspension or revocation until the person concerned has had an opportunity to make representations, except that it may suspend a licence with immediate effect if it considers it necessary. The right of appeal to the Tribunal is correspondingly expanded, with some exceptions (regulation 36(9)).

A Regulatory Appraisal has been prepared in respect of these Regulations. Copies can be obtained from the Department for Environment, Planning and Countryside, Welsh Assembly Government, Cathays Park, Cardiff CF10 3NQ.

**2005 No. 3038 (W.226)**

**SEEDS, WALES**

**The Seed (Registration, Licensing and Enforcement) (Wales) Regulations  
2005**

*Made*

*1 November 2005*

*Coming into force*

*18 November 2005*

ARRANGEMENT OF REGULATIONS

PART I

GENERAL

1. Title, commencement and application
2. General interpretation

PART II

REGISTRATION OF PERSONS ENGAGED IN SEED INDUSTRY ACTIVITIES

3. Obligation to be registered
4. Applications for registration
5. Registrations
6. Conditions to be complied with by registered persons
7. Termination of registrations
8. Revocation of registrations
9. List

PART III

LICENSED CROP INSPECTORS

10. Applications for licences
11. Licences
12. Variation of licences
13. Termination of licences
14. Suspension and revocation of licences
15. List
16. Fees

PART IV  
LICENSED SEED SAMPLERS

17. Applications for licences
18. Licences
19. Variation of licences
20. Termination of licences
21. Suspension and revocation of licences
22. List
23. Fees

PART V  
LICENSED SEED TESTING STATIONS

24. Applications for licences
25. Licences
26. Variation of licences
27. Examinations
28. Duties of seed analysts in charge of LSTSs
29. Suspension and revocation of licences
30. List
31. Fees

PART VI  
ENFORCEMENT OF SEEDS REGULATIONS

32. Sampling for enforcement purposes
33. Certificates of taking and testing a sample

PART VII  
MISCELLANEOUS AND SUPPLEMENTAL

34. Arrangements for official measures
35. Fees
36. Right to make representations
37. Appeals
38. Extension of time
39. Form of records
40. Form of lists
41. Service of notices
42. Revocations, transitional and savings provisions

SCHEDULE 1  
REGISTERED SEED INDUSTRY PERSONS

SCHEDULE 2  
LICENSED CROP INSPECTORS

SCHEDULE 3  
LICENSED SEED SAMPLERS

SCHEDULE 4  
LICENSED SEED TESTING STATIONS

SCHEDULE 5  
SAMPLING

SCHEDULE 6  
CERTIFICATE OF THE TAKING OF A SAMPLE OF SEEDS

SCHEDULE 7  
CERTIFICATES OF THE RESULTS OF TESTS OF SEEDS

The National Assembly for Wales, in exercise of the powers conferred on it by sections 16(1), (1A), (2), (3), (4) and (5A), 24(5), 26(2) and (3) and 36 of the Plant Varieties and Seeds Act 1964<sup>(1)</sup> after consultation in accordance with the said section 16(1) with representatives of such interests as appear to it to be concerned and with the Council on Tribunals in accordance with section 8(1) of the Tribunals and Inquiries Act 1992<sup>(2)</sup>, makes the following Regulations:

**PART I**  
**GENERAL**

**Title, commencement and application**

1.-(1) The title of these Regulations is the Seed (Registration, Licensing and Enforcement) (Wales) Regulations 2005.

(2) These Regulations come into force on 18 November 2005 and apply in relation to Wales.

---

(1) 1964 c. 14; section 16 was amended by section 4(1) of, and paragraph 5(1), (2) and (3) of, and Schedule 4 to the European Communities Act 1972 (c.68); *see* section 38(1) for a definition of "the Secretary of State". Under the Transfer of Functions (Wales)(No.1) Order 1978 (S.I. 1978/272), article 2(1) and Schedule 1, the functions of the Minister of Agriculture, Fisheries and Food under the Plant Varieties and Seeds Act 1964 were, so far as they are exercisable in relation to Wales, transferred to the Secretary of State; and under the National Assembly for Wales (Transfer of Functions) Order 1999 (S.I. 1999/672), article 2(1) and Schedule 1, the functions of the Secretary of State transferred by the 1978 transfer order were transferred to the National Assembly for Wales.

(2) 1992 c. 53. as amended by Section 125 of and paragraph 33 of Schedule 12 to, the Government of Wales Act 1998 (1998 c. 38)

## General interpretation

2.-(1) In these Regulations-

"the Act" means the Plant Varieties and Seeds Act 1964;

"Analyst in Charge" and "seed analyst" have the meaning given in regulation 27(1);

"authorised officer" means an officer authorised by the National Assembly, the Secretary of State, the Scottish Ministers or the Department of Agriculture and Rural Development for the purposes of these Regulations;

"the Department of Agriculture and Rural Development" means the Department of Agriculture and Rural Development in Northern Ireland;

"LSTS" means a laboratory in respect of which a licence has been granted pursuant to regulation 25;

"the National Assembly" means the National Assembly for Wales;

"official measures" includes-

- (a) matters connected with the registration of a person who may engage in a seed industry activity under Part II of these Regulations;
- (b) matters connected with the training, examination and licensing of crop inspectors under Part III of these Regulations;
- (c) matters connected with the training, examination and licensing of seed samplers under Part IV of these Regulations; and
- (d) matters connected with the licensing of seed testing stations and the training and examination of seed analysts and Analysts in Charge under Part V of these Regulations;

"prescribed minimum weight", in relation to a submitted sample, means the minimum weight of such a sample as prescribed in Schedule 7 of the appropriate Seed Marketing Regulations;

"registered person" means a person registered pursuant to regulation 5 as a person who may engage in a seed industry activity;

"the Secretary of State" means the Secretary of State for Environment, Food and Rural Affairs;

"seed" means seed of any species to which Seed Marketing Regulations apply;

"seed industry activity" means any of the following-

- (a) the marketing of seed other than the marketing-
  - (i) of small packages of seed, small EC packages of seed (as defined in each case in the Seed Marketing Regulations);
  - (ii) of unpacked seed;
  - (iii) by a producer of small quantities of seed for scientific purposes or selection work in compliance with an authorisation referred to in that connection in the Seed Marketing Regulations which would permit the marketing of such seed under those Regulations;
  - (iv) by a producer of seed for test and trial purposes in compliance with an authorisation referred to in that connection in the Seed Marketing Regulations (where applicable) which would permit the marketing of such seed under those Regulations;
  - (v) by or on behalf of a breeder of seed for market testing in compliance with an authorisation referred to in that connection in the Vegetable Seed (Wales) Regulations 2005 which would permit the marketing of such seed under those Regulations; or
  - (vi) of seed, as grown, for processing provided the identity of the seed is ensured;
- (b) the packing, sealing or labelling of seed (including the labelling or marking of standard seed of vegetables) except small packages of seed, small EC packages of seed (as defined in each case in the Seed Marketing Regulations);
- (c) the re-packing, re-sealing or re-labelling of seed;
- (d) the preparation of mixtures of seeds permitted by the Seed Marketing Regulations; and
- (e) the cleaning, treating or other processing of seed intended for marketing;

"the Seed Marketing Directives" means-



- (a) Council Directive 2002/54/EC(1) on the marketing of beet seed, as last amended by Council Directive 2004/117/EC(2);
- (b) Council Directive 66/402/EEC(3) on the marketing of cereal seed, as last amended by Council Directive 2004/117/EC;
- (c) Council Directive 66/401/EEC(4) on the marketing of fodder plant seed, as last amended by Council Directive 2004/117/EC;
- (d) Council Directive 2002/57/EC(5) on the marketing of oil and fibre plant seed as last amended by Council Directive 2004/117/EC; and
- (e) Council Directive 2002/55/EC(6) on the marketing of vegetable seed, as last amended by Council Directive 2004/117/EC;

"the Seed Marketing Regulations" means-

- (a) in relation to beet seed, the Beet Seed (Wales) Regulations 2005(7);
- (b) in relation to cereal seed, the Cereal Seed (Wales) Regulations 2005(8);
- (c) in relation to fodder plant seed, the Fodder Plant Seed (Wales) Regulations 2005(9);
- (d) in relation to oil and fibre plant seed, the Oil and Fibre Plant Seed (Wales) Regulations 2004(10); and
- (e) in relation to vegetable seed, the Vegetable Seed (Wales) Regulations 2005(11); and

"statutory seed testing" means seed testing carried out for the purposes of the Seed Marketing Regulations.

(2) Subject to paragraph (3), in these Regulations "marketing" means-

- (a) selling, holding with a view to sale and offering for sale, and
- (b) any disposal, supply or transfer for the purpose of commercial exploitation of seed to third parties,

whether or not for consideration, and "market" and "marketed" shall be construed accordingly.

(3) Trade in seed not aimed at commercial exploitation of the variety, such as the following operations-

- (a) the supply of seed to official testing and inspection bodies, and
- (b) the supply of seed to a person who provides processing or packaging services but who does not thereby acquire title to the seed supplied,

shall not be regarded as marketing of seed of that variety.

(4) All applications, statements of commitment, representations, notices and requests to which these Regulations apply shall be made in writing.

(5) "Writing" in paragraph (4) shall include an electronic communication within the meaning of the Electronic Communications Act 2000(12) provided that-

- (a) any document of the type referred to in paragraph (4) shall only be sent to the National Assembly by an electronic communication if the National Assembly has represented that electronic communication is a means by which persons can send such a document to it, and
- (b) notifications required to be made by the National Assembly to any person shall only be made by an electronic communication if the intended recipient has used the same form of electronic communication in communicating with the National Assembly pursuant to any provision of these Regulations or has otherwise represented that that form of electronic communication is a means by which the National Assembly can communicate with the intended recipient.

(1) OJ No. L. 193, 20.7.2002, p. 12.

(2) OJ No.L. 014, 18.1.2005, p. 18.

(3) OJ No. L. 125, 11.7.66, p. 2309.

(4) OJ No. L.125, 11.7.66, p. 2298.

(5) OJ No. L.193, 20.7.2002, p. 74.

(6) OJ No. L.193, 20.7.2002, p. 33.

(7) S.I. 2005/3037 (W.225)

(8) S.I. 2005/3036 (W.224)

(9) S.I. 2005/1207 (W.79)

(10) S.I. 2004/2881 (W.251)

(11) S.I. 2005/3035 (W.223)

(12) 2000 c. 7.

(6) Expressions in these Regulations which are not defined in the preceding paragraphs of this regulation and which appear in the Seed Marketing Regulations have the same meaning in these Regulations as they have in those Regulations.

## **PART II**

### **REGISTRATION OF PERSONS ENGAGED IN SEED INDUSTRY ACTIVITIES**

#### **Obligation to be registered**

3. No person shall engage in a seed industry activity unless the person is registered by the National Assembly as a person who may engage in that activity.

#### **Applications for registration**

4.-(1) A person may apply to the National Assembly to be registered as a person who may engage in a seed industry activity.

(2) An application made under paragraph (1) may relate to all seed industry activities or to any one or more of them and shall-

- (a) be made in such form and manner as the National Assembly may require; and
- (b) be accompanied by such information relating to the applicant's proposed business and such other information as the National Assembly may reasonably require for the purpose of determining whether the applicant is a suitable person to be registered as a person who may engage in the seed industry activity to which his or her application relates.

#### **Registrations**

5.-(1) Where an application is made under regulation 4 the National Assembly shall, after carrying out such investigations and inspections as it may think fit, register the applicant as a person who may engage in the seed industry activity to which his or her application relates if it is satisfied that the applicant is a suitable person to engage in such activity.

(2) In deciding whether an applicant is a suitable person to engage in the seed industry activity to which his or her application relates the National Assembly may take into account the matters specified in Part I of Schedule 1.

#### **Conditions to be complied with by registered persons**

6. A registration granted under regulation 5 may be subject to any of the conditions specified in Part II of Schedule 1 and such other conditions as the National Assembly may think necessary or desirable.

#### **Termination of registrations**

7. If a registered person requests the National Assembly to terminate his or her registration in respect of any or all of the seed industry activities that the person is registered as being entitled to engage in the National Assembly shall comply with the request.

#### **Revocation of registrations**

8. Subject to regulation 36, the National Assembly may revoke a person's registration relating to his or her entitlement to engage in a seed industry activity if-

- (a) it is satisfied that the person is not complying with any of the conditions to which his or her registration is subject;
- (b) it is satisfied that there is no longer available to the person such premises, machinery, equipment, facilities or personnel and services as are necessary to enable the person to engage in the seed industry activity;
- (c) the person has been found guilty of committing any offence under section 16(7) of the Act; or
- (d) it is otherwise no longer satisfied that the person is a suitable person to engage in the seed industry activity.

## **List**

### **9. The National Assembly-**

- (a) shall keep a list containing the names and addresses of registered persons who may engage in a seed industry activity specifying, in the case of each registered person, the seed industry activity in respect of which they are registered;
- (b) shall make the list available for inspection by any person at any reasonable time; and
- (c) may from time to time publish the list in such manner as it thinks appropriate.

## **PART III**

### **LICENSED CROP INSPECTORS**

#### **Applications for licences**

**10.-(1)** An individual may apply to the National Assembly for a licence authorising the individual to inspect crops grown to produce seed of any one or more of the species and categories listed in Part I of Schedule 2.

(2) An application made under paragraph (1) shall be in such form and manner as the National Assembly may require and be accompanied by such information as the National Assembly may reasonably require

#### **Licences**

**11.-(1)** Where an application is made under regulation 10(1) the National Assembly shall grant the applicant a licence authorising the applicant to inspect crops of the species and category to which the application relates if it is satisfied that the applicant has-

- (a) completed an appropriate training course relating to the inspection of seed crops of that species and category;
- (b) passed an examination relating to the inspection of seed crops of that species and category organised by or on behalf of the National Assembly, the Secretary of State, the Scottish Ministers or the Department of Agriculture and Rural Development; and
- (c) signed a statement of commitment to carry out his or her functions in accordance with such instructions as may from time to time be issued by or on behalf of the National Assembly.

(2) A licence granted under paragraph (1)-

- (a) shall specify which of the functions listed in Part II of Schedule 2 are covered by the licence; and
- (b) may impose any of the conditions listed in Part III of Schedule 2 and such other conditions as the National Assembly may think necessary or desirable having regard to the species and category of crops that may be inspected by the licence holder.

(3) A licensed crop inspector who is employed by a person who is engaged in a seed industry activity shall carry out crop inspections only on crops grown by or on behalf of his or her employer unless otherwise agreed between his or her employer, the applicant for certification and by the National Assembly.

#### **Variation of licences**

**12.-(1)** A crop inspector may apply to the National Assembly for the crop inspector's licence to be varied so as to authorise the crop inspector to inspect crops being grown to produce seed of another species and category listed in Part I of Schedule 2 in addition to the species and category specified in his or her licence or instead of such species and category.

(2) Where an application is made under paragraph (1) it shall be treated as though it had been made under regulation 10(1) and the National Assembly may vary a crop inspector's licence so as to authorise the crop inspector to inspect crops of the species and category to which the crop inspector's application relates if it is satisfied that the applicant has satisfied the requirements of regulation 11(1).

(3) In varying a licence under paragraph (2) the National Assembly may vary the functions of the crop inspector specified in his or her licence and the conditions imposed by his or her licence.

(4) Subject to regulation 36, the National Assembly may vary a crop inspector's licence whether or not it has received any application under this regulation by-

- (a) removing his or her authorisation to inspect a species and category of crop if it is satisfied that the crop inspector is no longer qualified to inspect crops of that species and category or that his or her authorisation to inspect such crops is otherwise no longer appropriate; or
- (b) varying the functions or the conditions set out in the licence.

#### **Termination of licences**

13. If a licensed crop inspector requests the National Assembly to terminate his or her licence the National Assembly shall comply with the request.

#### **Suspension and revocation of licences**

14. Subject to regulation 36, the National Assembly may suspend or revoke a licensed crop inspector's licence if it is satisfied that the licence holder-

- (a) is no longer qualified to inspect crops of the species and category to which his or her licence relates or is otherwise unfit to perform any of the functions of a licensed crop inspector specified in the licence, or
- (b) has failed to comply with any of the conditions imposed on the holder by the licence.

#### **List**

15. The National Assembly-

- (a) shall keep a list of the names and addresses of licensed crop inspectors and shall specify in the case of each crop inspector the species and category of crops which the crop inspector is licensed to inspect;
- (b) shall make the list available for inspection by any person at any reasonable time; and
- (c) may from time to time publish the list in such manner as it thinks appropriate.

#### **Fees**

16. A licensed crop inspector may charge reasonable fees for carrying out his or her functions as a licensed crop inspector but shall not derive any private gain in connection with the carrying out of such functions.

## **PART IV**

### **LICENSED SEED SAMPLERS**

#### **Applications for licences**

17.-(1) An individual may apply to the National Assembly for a licence authorising the individual to take samples of seed of the species specified in Part I of Schedule 3 for the purposes of the Seed Marketing Regulations.

(2) An application made under paragraph (1) shall be made in such form and manner as the National Assembly may require and shall be accompanied by such information as the National Assembly may reasonably require.

#### **Licences**

18.-(1) Where an application is made under regulation 17 the National Assembly shall grant the applicant a seed sampler's licence if-

- (a) it is satisfied that the applicant has undertaken a training course on seed sampling organised by or on behalf of the National Assembly, the Secretary of State, the Scottish Ministers or the Department of Agriculture and Rural Development; and
- (b) the applicant, having completed such a course, has passed an examination on seed sampling organised by or on behalf of the National Assembly, the Secretary of State, the Scottish Ministers or the Department of Agriculture and Rural Development.

(2) A licence granted under paragraph (1)-

- (a) shall specify which of the functions listed in Part II of Schedule 3 are covered by the licence and may in addition specify any other functions which the National Assembly thinks necessary or desirable; and
- (b) may impose any of the conditions listed in Part III of Schedule 3 and such other conditions as the National Assembly may think necessary or desirable.

(3) A licensed seed sampler who is employed by a person who is engaged in a seed industry activity shall only sample seed lots produced by or on behalf of his or her employer unless otherwise agreed between his or her employer, the applicant for certification and by the National Assembly.

#### **Variation of licences**

19. Subject to regulation 36, the National Assembly may vary a seed sampler's licence as it thinks fit.

#### **Termination of licences**

20. If a seed sampler requests the National Assembly to terminate his or her licence the National Assembly shall comply with the request.

#### **Suspension and revocation of licences**

21. Subject to regulation 36, the National Assembly may suspend or revoke a seed sampler's licence if it is satisfied that the seed sampler-

- (a) is no longer qualified to sample seed or is otherwise unfit to perform any of the functions specified in his or her licence; or
- (b) is not carrying out the functions specified in his or her licence or complying with the conditions imposed on the seed sampler by the licence.

#### **List**

22. The National Assembly-

- (a) shall keep a list of the names and addresses of licensed seed samplers;
- (b) shall make the list available for inspection by any person at any reasonable time; and
- (c) may from time to time publish the list in such manner as it thinks appropriate.

#### **Fees**

23. A licensed seed sampler may charge reasonable fees for carrying out his or her functions as a licensed seed sampler but shall not derive any private gain in connection with the carrying out of such functions.

## **PART V**

### **LICENSED SEED TESTING STATIONS**

#### **Applications for licences**

24.-(1) A person may apply to the National Assembly for an establishment to be licensed as a laboratory that may be used for carrying out statutory seed testing.

(2) An application made under paragraph (1) may relate to any species of seed to which the Seed Marketing Regulations apply.

(3) An application made under paragraph (1) shall-

- (a) contain the name and address of the applicant and, where different, the person who shall be in charge of the laboratory (the "person in charge");

- (b) be accompanied by details of the laboratory and species of seed in respect of which a licence is sought; and
- (c) contain such other information as the National Assembly may reasonably require for the purpose of considering the matters to be taken into account in Part I of Schedule 4.

### **Licences**

**25.**-(1) Where an application is made in accordance with regulation 24 the National Assembly shall license the establishment to be used as a laboratory that may carry out statutory seed testing of the species specified in that application if it is satisfied that the laboratory is suitable having regard to the matters to be taken into account in Part I of Schedule 4.

(2) A LSTS belonging to a registered person shall only carry out statutory seed testing on seed lots produced by or on behalf of that person unless otherwise agreed between the registered person, the applicant for certification and the National Assembly.

(3) The licence shall be subject to the conditions set out in Part II of Schedule 4 and such other conditions as the National Assembly may think necessary or desirable having regard to the species of seed to be tested, the nature of the tests to be carried out and the procedure to be followed in connection with such tests.

### **Variation of licences**

**26.**-(1) The person in charge of a LSTS may apply to the National Assembly for the licence held in respect of that LSTS to be varied so as to authorise its use as a laboratory that may carry out statutory seed testing on another species of seed in addition to the species specified in the licence or instead of such species.

(2) Where an application is made under paragraph (1) the National Assembly shall vary the licence so as to authorise the laboratory to which it relates to carry out statutory seed testing on the species of seed to which that application relates if it is satisfied that the laboratory is suitable, having regard to the matters to be taken into account in Part I of Schedule 4.

(3) In varying a licence under paragraph (2) the National Assembly may vary the conditions imposed by the licence.

(4) Subject to regulation 36, the National Assembly may vary a LSTS licence whether or not it has received any application under this regulation-

- (a) by removing the authorisation relating to the statutory seed testing of a species of seed if it is satisfied that the LSTS is no longer suitable to carry out statutory seed tests in respect of that species or that the authorisation to test such seed is otherwise no longer appropriate; or
- (b) by varying the conditions imposed by a LSTS licence.

### **Examinations**

**27.**-(1) For the purposes of this Part and Schedule 4-

- (a) a seed analyst is a person who-
  - (i) has completed a training course organised by, or on behalf of, the National Assembly, the Secretary of State, the Scottish Ministers or the Department of Agriculture and Rural Development relating to seed testing in respect of seed of the species being tested, or to be tested, by the person; and
  - (ii) having completed such a course, has passed the relevant examination organised by, or on behalf of, the National Assembly, the Secretary of State, the Scottish Ministers or the Department of Agriculture and Rural Development;
- (b) an Analyst in Charge is a person who, being also a seed analyst, has-
  - (i) completed the training course and passed the examination required of a seed analyst in respect of seed of each of the species which may be tested at the LSTS for which he or she has, or is to have, responsibility; and
  - (ii) passed an examination relating to laboratory management organised by, or on behalf of, the National Assembly, the Secretary of State, the Scottish Ministers or the Department of Agriculture and Rural Development.

(2) The National Assembly may from time to time require any seed analyst carrying out statutory seed testing at

a LSTS or the Analyst in Charge of a LSTS to attend such further training courses and undergo such further examinations as it considers appropriate in order to maintain his or her knowledge and qualifications in respect of his or her functions at the LSTS.

#### **Duties of seed analysts in charge of LSTSs**

**28.** A person acting as the Analyst in Charge of a LSTS shall-

- (a) have direct responsibility for the technical operations of the LSTS ;
- (b) be in effective control of all the statutory seed testing carried out at the LSTS; and
- (c) exercise close supervision of the work of any seed analyst assisting the person in connection with statutory seed testing carried out at the LSTS.

#### **Suspension and revocation of licences**

**29.** Subject to regulation 36, the National Assembly may suspend or revoke a LSTS licence if it appears to it that-

- (a) there has been a breach of any conditions of the licence;
- (b) a person acting as a Analyst in Charge of a LSTS-
  - (i) is no longer qualified to act as such,
  - (ii) has failed to comply with the duties imposed on the person by regulation 28, or
  - (iii) is otherwise unfit to perform his or her duties; or
- (c) a seed analyst carrying out statutory seed testing at the LSTS is no longer qualified to do so.

#### **List**

**30.** The National Assembly

- (a) shall prepare a list of LSTSs and shall specify in the case of each LSTS the species of seed which it is licensed to test;
- (b) shall make the list available for inspection by any person at any reasonable time; and
- (c) may from time to time publish the list in such manner as it thinks appropriate.

#### **Fees**

**31.**-(1) The person in charge of a LSTS may charge reasonable fees for statutory seed testing carried out on seed at the LSTS but shall not derive any private gain from such tests.

(2) The National Assembly may charge the person in charge of a LSTS reasonable fees in respect of costs incurred by the National Assembly in connection with the licensing and supervision of the LSTS and the statutory seed testing carried out there.

## **PART VI**

### **ENFORCEMENT OF SEEDS REGULATIONS**

#### **Sampling for enforcement purposes**

**32.**-(1) A sample of seed taken for the enforcement of the Seed Marketing Regulations or these Regulations shall be taken and divided by an authorised officer in accordance with the requirements contained in Schedule 5 to provide three parts of which-

- (a) one part shall be delivered or sent to the owner of the seed or his or her representative; and
- (b) two parts shall be delivered or sent to an official seed testing station, one of which parts shall be officially examined for the purposes of the appropriate Seed Marketing Regulations and the other of which shall be retained by such person for production to a court in accordance with section 26(7) of the Act,

except that where it appears to the person taking the sample that the seed from which the sample has been taken was purchased for use and not for resale, the first part of the sample shall be delivered or sent to the last seller of the seed or to his or her representative instead of to the owner of the seed or his or her representative.

(2) Where a part of a sample taken under this regulation has been officially examined for the purposes of the appropriate Seed Marketing Regulations, any residue from the sample may be used for such other tests as the National Assembly may direct including for the purpose of the Community comparative tests referred to in the corresponding Seed Marketing Directives.

(3) Subject to paragraph (4), the minimum weight of the sample of seed shall be such as to ensure that each of the parts into which it is divided is of not less than the prescribed minimum weight for the sample.

(4) Where the seed from which a sample is to be taken for the enforcement of the Vegetable Seed (Wales) Regulations 2005 is contained in small packages, the sample shall consist of as many such packages as the person taking the sample may reasonably require.

### **Certificates of taking and testing a sample**

**33.**-(1) A certificate in the form set out in Schedule 6 of the taking of a sample of seed for the enforcement of Seed Marketing Regulations is prescribed for the purposes of section 26(3) of the Act.

(2) A certificate of the result of a test of a sample of seed carried out for the enforcement of the Seed Marketing Regulations is prescribed for the purposes of section 24(5) of the Act, in the form set out in Schedule 7 which corresponds with the species of seed tested.

## **PART VII**

### **MISCELLANEOUS AND SUPPLEMENTAL**

#### **Arrangements for official measures**

**34.**-(1) Subject to the following provisions of this regulation, the National Assembly may make arrangements, in such form as it is of the opinion may be necessary or desirable, for the purpose of enabling any person to act under its responsibility or control to carry out official measures.

(2) The National Assembly shall not make arrangements under this regulation unless it is satisfied that it will make provision for the purpose of preventing the person with whom the arrangement is made, and any other person, from-

- (a) deriving any private gain from any official measures carried out under the arrangement; and
- (b) carrying out any official measures under the arrangement except under the supervision of the National Assembly.

(3) An arrangement under this regulation may include such conditions as the National Assembly is of the opinion are necessary or desirable for the purposes referred to in paragraphs (1) and (2), including conditions-

- (a) specifying-
  - (i) the official measures that the person with whom the arrangement is made shall carry out under it;
  - (ii) the fees that may be charged by the person with whom the arrangement is made in relation to the official measures being carried out; and
  - (iii) the records that must be kept by the person with whom the arrangement is made in connection with the official measures being carried out; and
- (b) prohibiting the person with whom the arrangement is made from-
  - (i) carrying out the official measures except under official supervision; and
  - (ii) charging fees in relation to official measures carried out under the arrangement except to the extent that these do not exceed the costs incurred in carrying them out;.

(4) The National Assembly may vary, suspend or revoke an arrangement or the conditions of an arrangement made under this regulation, by giving notice to the person with whom the arrangement is made.



(5) A notice of a variation, suspension or revocation of any arrangement or of a condition of an arrangement shall specify-

- (a) in respect of a variation or a revocation, a date on and after which the variation or revocation shall have effect, and
- (b) in respect of a suspension, a period during which the suspension shall have effect,

and the variation, suspension or revocation shall have effect in accordance with the notice.

(6) When a variation, suspension or revocation has effect the National Assembly may, for any purposes in relation to these Regulations or a determination under these Regulations, continue to have regard to such of the official measures carried out under an arrangement which was varied, suspended or revoked as appear to it to be official measures carried out in accordance with the provisions of these Regulations.

## **Fees**

**35.**-(1) The National Assembly may charge any person, including any person with whom an arrangement has been made under regulation 34, reasonable fees in respect of the costs the National Assembly reasonably incurs in carrying out official measures for the purposes of these Regulations.

(2) A person with whom an arrangement has been made in accordance with regulation 34, may charge any other person reasonable fees in respect of costs reasonably incurred in carrying out official measures under the responsibility or control of the National Assembly in accordance with these Regulations.

(3) Where a person has been given notice-

- (a) by or on behalf of the National Assembly of a fee duly charged in accordance with paragraph (1); or
- (b) by a person with whom an arrangement has been made under regulation 34 of a fee duly charged in accordance with paragraph (2),

the person given the notice shall pay as specified in the notice the amount of the fee so charged.

## **Right to make representations**

**36.**-(1) The National Assembly shall not-

- (a) refuse to register a person as a person who may engage in a seed industry activity;
- (b) revoke the registration of a person as a person who may engage in a seed industry activity;
- (c) refuse to grant or vary a crop inspector's licence;
- (d) vary a crop inspector's licence pursuant to regulation 12(4);
- (e) suspend or revoke a licensed crop inspector's licence;
- (f) refuse to grant a seed sampler's licence
- (g) vary a licensed seed sampler's licence;
- (h) suspend or revoke a licensed seed sampler's licence;
- (i) refuse to grant or vary a LSTS licence;
- (j) vary a LSTS licence pursuant to regulation 26(4); or
- (k) suspend or revoke a LSTS licence;

unless it has complied with the provisions of this regulation.

(2) The National Assembly shall-

- (a) give the person concerned notice stating what it is proposing to do and the reasons for it; and
- (b) inform the person concerned of his or her right to make representations to it and of the manner in which and the time (not being less than 21 days from the giving of the notice) within which such representations may be made.

(3) In this regulation, the person concerned in the case of any notice served in connection with a LSTS shall be the person in charge of the LSTS.

(4) Subject to paragraph (5), the National Assembly shall not proceed with its proposed refusal, variation, suspension or revocation (as the case may be) until the period allowed for making representations has passed.

(5) Where the National Assembly considers it necessary to suspend a crop inspector's licence, a seed sampler's licence or a LSTS licence, with immediate effect, it may do so notwithstanding the right of the person concerned to make representations and when it gives notice of its decision under paragraph (7) it shall-

- (a) indicate whether the suspension should for the time being remain in force; or
- (b) withdraw the suspension of the licence.

(6) A person who makes representations to the National Assembly shall provide the National Assembly with a copy of any document upon which that person seeks to rely within the time allowed for the making of such representations.

(7) The National Assembly shall consider any representations made to it under this regulation before giving the person concerned notice of its decision together with the reasons for it and, where appropriate, of the date from which the decision shall have effect.

(8) A notice under paragraph (7) shall where applicable inform the person concerned of-

- (a) his or her right to appeal to the Tribunal<sup>(1)</sup> against the National Assembly's decision; and
- (b) the time within which such an appeal may be brought.

(9) There shall be no right of appeal to the Tribunal where the National Assembly-

- (a) has refused to grant a crop inspector's licence or a seed sampler's licence for the sole reason that that person failed to pass the relevant examination for the grant of the licence;
- (b) has refused to vary a crop inspector's licence for the sole reason that that person failed to pass the relevant examination for the variation of the licence; or
- (c) has decided that a licensed crop inspector or licensed seed sampler is no longer qualified to inspect crops or sample seed (as the case may be) and has-
  - (i) in the case of a crop inspector varied, suspended or revoked his or her licence, or
  - (ii) in the case of a licensed seed sampler suspended or revoked his or her licence

for the sole reason that that person failed to pass an examination which that person was required to undergo as a condition of his or her licence.

(10) The National Assembly may charge any person making representations under this regulation reasonable fees in that connection which shall be payable on making the representations to it.

## **Appeals**

37.-(1) A person notified of his or her right to appeal under regulation 36(8) may bring an appeal to the Tribunal.

(2) The National Assembly shall take such steps as may be necessary to give effect to any decision of the Tribunal given on the final determination of an appeal under paragraph (1).

## **Extension of time**

38. Where any document is to be delivered or given or any act is to be done in a time prescribed by these Regulations the National Assembly may, if in all the circumstances of the case it considers it reasonable, extend the time for such period and upon such terms as it thinks fit.

## **Form of records**

39. Any record required to be kept under these Regulations may be in written or electronic form and shall be kept for at least three years.

## **Form of lists**

40. Any list required to be kept by the National Assembly under these Regulations may be in written or electronic form.

## **Service of notices**

41.-(1) Any notice required by virtue of these Regulations to be given to any person by the National Assembly

---

(1) Plant Varieties and Seed Tribunal as defined in S.38(1) of the Plant Varieties and Seeds Act 1964.

may be given by it-

- (a) by delivering it to the person or by leaving it at the person's proper address or by sending it by post to the person at that address;
- (b) if the person is a body corporate other than a limited liability partnership, by giving it in accordance with paragraph (a) on the secretary of the body;
- (c) if the person is a limited liability partnership, by giving it in accordance with paragraph (a) on a member of the partnership; or
- (d) if the person is a partnership, by giving it in accordance with paragraph (a) on a partner or a person having control of the management of the partnership business.

(2) For the purposes of this regulation and section 7 of the Interpretation Act 1978<sup>(1)</sup> (service of documents by post) in its application to this regulation, the proper address of any person to whom a notice is to be given shall be his or her last known address, except that-

- (a) in the case of a body corporate (other than a limited liability partnership) or its secretary, it shall be the address of the registered or principal office of the body;
- (b) in the case of a limited liability partnership or a member of the partnership, it shall be the address of the registered or principal office of the partnership; and
- (c) in the case of a partnership or a partner or a person having the control or management of a partnership business, it shall be the address of the principal office of the partnership.

(3) Paragraph (4) applies if a person to be given a notice under these Regulations by the National Assembly has specified to it an address within the United Kingdom other than his or her proper address (as determined under paragraph (2)) as the one at which the person or someone on his or her behalf will accept notices of that description.

(4) In relation to that notice, that address shall be treated as his or her proper address for the purposes of this regulation and section 7 of the Interpretation Act 1978 in its application to this regulation, instead of that determined under paragraph (2).

#### **Revocations, transitional and savings provisions**

**42.**-(1) Subject to the following provisions of this regulation, the following Regulations are revoked-

- (a) The Seeds (Registration, Licensing and Enforcement) Regulations 1985<sup>(2)</sup> ("the 1985 Regulations") in relation to Wales and
- (b) The Seed (Fees) Regulations 1985<sup>(3)</sup> ("the 1985 Fees Regulations") in relation to matters arising under the 1985 Regulations in relation to Wales.

(2) Any application made to the National Assembly in accordance with regulation 4(2) of the 1985 Regulations but not determined at the coming into force of these Regulations shall be treated as an application referred to in regulation 4(1) of these Regulations and shall be determined in accordance with these Regulations.

(3) Any registration made pursuant to regulation 4(3) of the 1985 Regulations and having effect at the coming into force of these Regulations shall have effect as though it were a registration made pursuant to regulation 5 of these Regulations;

(4) Subject to paragraph (6)-

- (a) any licence granted to a seed testing station pursuant to regulation 9(1) of the 1985 Regulations and having effect at the coming into force of these Regulations shall have effect as though it were a licence granted pursuant to regulation 25 of these Regulations; and
- (b) any licence granted to a crop inspector or seed sampler pursuant to regulation 10(1) of the 1985 Regulations and having effect at the coming into force of these Regulations shall have effect as though it were a licence granted pursuant to regulation 11 of these Regulations in the case of a crop inspector and regulation 18 of these Regulations in the case of a seed sampler.

---

(1) 1978 c.30.

(2) S.I. 1985/980, as amended by S.I. 1987/1098, S.I. 1990/611 and S.I. 1993/2530.

(3) S.I. 1985/981, as last amended by S.I. 1990/610, S.I. 1999/1865 and, as respects England, S.I. 2002/1563.

(5) The right to make representations pursuant to regulation 36 of these Regulations and to appeal to the Tribunal pursuant to regulation 37 of these Regulations shall not apply in respect of any licence which was granted under the 1985 Regulations and which is varied within three months of the coming into force of these Regulations.

(6) Any fee arising (whether wholly or in part) under the 1985 Regulations or the 1985 Fees Regulations but not paid at the coming into force of these Regulations shall be treated as a fee arising under these Regulations and shall be recoverable accordingly.

Signed on behalf of the National Assembly for Wales under section 66(1) of the Government of Wales Act 1998<sup>(1)</sup>

1 November 2005

*D. Elis-Thomas*

The Presiding Officer of the National Assembly

---

(1) 1998 c.38.

SCHEDULE 1  
REGISTERED SEED INDUSTRY PERSONS

**PART I**

**Registration: matters that may be taken into account**

1. The premises that are available to the applicant.
2. The machinery, equipment and facilities that are available to the applicant.
3. In relation to seed mixtures intended for use as fodder plants, the appropriateness of the procedures employed by the applicant in carrying out mixing operations.
4. The personnel and services that are available to the applicant.
5. Where the applicant is a corporate body or a partnership, the individual who is nominated as the point of contact ("the nominated contact") within the organisation for all communications relating to compliance with the Seed Marketing Regulations and with these Regulations.
6. When the activities carried out by the applicant include the preparation of seed mixtures intended for use as fodder plants, the individual who has direct responsibility for the mixing operations.

**PART II**

**Conditions which may be imposed on a registered person**

1. In the case of a company, to notify the National Assembly within 21 days of any change of the company's name or the address of its registered office or any premises being used by it for the purpose of carrying on any seed industry activity.
2. In the case of a registered person other than a company, to notify the National Assembly within 21 days of any change of address of the registered person or of premises being used by the registered person for the purpose of the carrying on any seed industry activity;
3. In the case of a corporate body or a partnership, to notify the National Assembly within 21 days of any change regarding the nominated contact.
4. In the case of the preparation of seed mixtures intended for use as fodder plants, to notify the National Assembly within 21 days of any change regarding the person with direct responsibility for the mixing operation.
5. To keep such records as the National Assembly may require of his or her transactions in seeds and of the treatment, testing and other operations undertaken by the registered person or on his or her behalf in relation to any seeds or their disposal including records relating to-
  - (a) seed crops;
  - (b) the date on which official labels are used (by reference to the unique label number) and the seed lots for which they are used;
  - (c) in the case of seed intended for marketing, the number and weight of seed lots processed and the date on which they are processed by species, category and level;
  - (d) the date on which official samples are taken from seed lots and the identity of the authorised officer or licensed seed sampler;
  - (e) the date on which official samples are despatched to a LSTS for testing;

- (f) in the case of a seed lot that is officially certified for early movement, the date on which the interim seed test report is issued, the date on which the seed test report is issued and, in a case where the official germination test shows that the seed fails to meet the appropriate germination standard for seed of that species, the date on which the seller notifies the purchaser of the seed of the position;
- (g) the date on which and from whom the registered person buys seed and the date on which and to whom the registered person sells it (by crop identity number or seed lot reference number) and the weight of the seed bought or sold; and
- (h) in the case of any seed which the registered person treats chemically, the date on which the seed is so treated and details of the treatment applied.

6. To keep a register of seed mixtures intended for use as fodder plants.

7. To permit, at any reasonable time, an authorised officer to inspect and take copies of the records specified in paragraph 5 and of the register specified in paragraph 6.

8. To permit, at any reasonable time, an authorised officer to inspect the premises, machinery, equipment and facilities used by or available to the registered person for the carrying on of the seed industry activity in respect of which the person is registered.

9. To give the National Assembly such other information as it may reasonably require in connection with the seed industry activity in respect of which the person is registered.

SCHEDULE 2

LICENSED CROP INSPECTORS

**PART I**

**Species and categories of seed crop that may be inspected by a licensed crop inspector**

All categories of seed of a species to which the Seed Marketing Regulations apply except pre-basic and basic seed.

**PART II**

**Functions that may be specified in a crop inspector's licence**

1. To authenticate each seed lot sown to produce a seed crop and to record at least one label serial number used for such authentication.
2. To inspect crops in accordance with instructions from time to time issued by or on behalf of the National Assembly for the purposes of the Seed Marketing Regulations to determine whether the crops meet the relevant standards prescribed in the Seed Marketing Regulations including-
  - (a) confirmation of the identity of the variety insofar as possible;
  - (b) the detection and recording of any species impurities or varietal impurities;
  - (c) the checking of compliance with isolation requirements; and
  - (d) the assessment of the general condition of the crop including-
    - (i) whether the crop is in a suitable condition for inspection;
    - (ii) any pesticide spray damage that may have been caused to the crop; and
    - (iii) the existence of weeds and diseases.
3. To issue a field inspection report following the inspection of a seed crop in accordance with Seed Marketing Regulations.
4. To submit to the National Assembly such other reports on the inspection of crops carried out by the crop inspector as the National Assembly may, from time to time, require.
5. To keep records of crops inspected by the crop inspector.
6. To supervise other licensed crop inspectors as directed by the National Assembly.

**PART III**

**Conditions that may be imposed by a crop inspector's licence**

1. To carry out his or her functions as a licensed crop inspector subject to the supervision of authorised officers.
2. To carry out his or her functions as a licensed crop inspector subject to supervision by other licensed crop inspectors authorised by the National Assembly in that behalf.
3. To carry out his or her functions as a licensed crop inspector in accordance with instructions relating thereto issued by or on behalf of the National Assembly.

4. To maintain his or her expertise by making regular inspections of crops for the purpose of the Seed Marketing Regulations.
5. To attend such training courses and undergo such examinations on the official inspection of crops as the National Assembly may, from time to time, require.
6. To notify the National Assembly within 21 days of any change in his or her contact address.
7. To inspect not more than the maximum areas, if any, specified by the National Assembly.



**SCHEDULE 3**  
**LICENSED SEED SAMPLERS**

**PART I**

**Species of seed that may be sampled by a licensed seed sampler**

All seed of a species to which the Seed Marketing Regulations apply.

**PART II**

**Functions that may be specified in a seed sampler's licence**

1. To sample seed in accordance with the Seed Marketing Regulations and to submit sealed samples of such seed for an official examination or examination under official supervision.
2. To keep records of seed lots sampled by the seed sampler and the methods of sampling used.
3. To keep records of the use by the seed sampler of labels issued or authorised by the National Assembly.
4. To ensure that packages of seed are labelled or re-labelled and sealed or re-sealed in accordance with the Seed Marketing Regulations.
5. To ensure that mixtures of seed are, labelled or re-labelled and sealed or re-sealed in accordance with the Seed Marketing Regulations.
6. To ensure that sampling equipment, including automatic sampling devices, operated by the seed sampler in carrying out his or her functions operates correctly at all times.

**PART III**

**Conditions that may be imposed by a seed sampler's licence**

1. To carry out his or her functions subject to supervision by authorised officers.
2. To carry out his or her functions in accordance with any instructions relating thereto issued by or on behalf of the National Assembly.
3. To attend such training courses and undergo such examinations as the National Assembly may, from time to time, require.
4. To notify the National Assembly within 21 days of any change in his or her residential address.

## SCHEDULE 4

### LICENSED SEED TESTING STATIONS

#### PART I

##### **Licensing of laboratories: matters to be taken into account**

1. The premises in which the laboratory is situated.
2. The equipment that is available at the laboratory for carrying out statutory seed testing.
3. The knowledge and qualifications-
  - (a) in seed testing and laboratory management of the Analyst in Charge; and
  - (b) in seed testing of any seed analysts

who staff, or will staff, the laboratory in respect of which the application is made.

#### PART II

##### **LSTS licence conditions**

1. The LSTS shall have a person acting as the Analyst in Charge.
2. All statutory seed testing carried out at the LSTS shall be carried out by a seed analyst or the Analyst in Charge of the LSTS.
3. Any change regarding the person appointed to act as the Analyst in Charge of the LSTS or regarding the person in charge of the LSTS shall be notified to the National Assembly within 21 days.
4. The premises in which the LSTS is maintained shall be satisfactory for the purpose of carrying out statutory seed testing and shall be equipped with equipment that enables the seed tests to be carried out in accordance with current international methods specified by the National Assembly.
5. The LSTS shall be open to inspection at all reasonable times by an authorised officer.
6. Statutory seed testing shall be carried out in accordance with current international methods specified by the National Assembly.
7. A record shall be kept of all statutory seed tests carried out at the LSTS.
8. The records referred to in paragraph 7 shall be available for inspection at all reasonable times by an authorised officer.
9. A portion (in this Schedule called "the reserve portion") of every sample of seed submitted for statutory seed testing shall be taken from the submitted sample in accordance with a method specified by the National Assembly and shall be at least the prescribed minimum weight.
10. The reserve portion shall be placed in a bag and the bag shall be identified, sealed and retained under good storage conditions in accordance with instructions issued by the National Assembly. It shall not be opened during the period specified in the instruction except by or on the authority of an authorised officer.
11. The reserve portion shall be delivered to an authorised officer on request.

## SCHEDULE 5

## SAMPLING

1. A sample shall be obtained from the seed lot by taking primary samples systematically or at random from different positions in the lot and combining them to form a composite sample. The composite sample may be submitted for testing intact but if the composite sample is too large it may be reduced in weight by using a riffle divider or a centrifugal divider, to give the submitted sample.

**Primary sample size**

2. At each position of sampling of a seed lot, primary samples of approximately equal size shall be taken.

**Condition of the Seed Lot**

3. The seed lot to be sampled shall have been subject to appropriate mixing and blending techniques so that it is as uniform as practicable. There shall be no documentary or other evidence of heterogeneity. If a seed lot is presented for sampling in more than one container, the containers shall be of the same size and type and contain approximately the same weight of seed.

4. When the seed lot is in sacks or similar sized containers each containing at least 15 kg of seed and not more than 100 kg of seed, the minimum number of containers to be sampled shall be in accordance with the following table:-

NUMBER OF CONTAINERS IN THE LOT	MINIMUM NUMBER OF CONTAINERS TO BE SAMPLED
1- 4	3 primary samples from each container.
5- 8	2 primary samples from each container.
9- 15	1 primary sample from each container.
16- 30	A total of 15 primary samples with each sample being taken from a different container.
31- 59	A total of 20 primary samples with each sample being taken from a different container.
60 or more	A total of 30 primary samples with each sample being taken from a different container.

5. The containers to be sampled shall be selected systematically or at random and primary samples drawn from the top, middle and the bottom of containers, but not necessarily from more than one position in any container. The position from which the seed is taken shall be varied from container to container.

**Sampling from small containers**

6. For sampling seed lots in containers holding less than 15kg of seed, a 100kg weight of seed shall be taken as the basic unit and the small containers shall be combined to form sampling units not exceeding this weight (for example, eight packages of 12kg or twenty packages of 5kg). For sampling purposes each unit shall be regarded as one container and the sampling procedures prescribed in paragraphs 4 and 5 shall be used.

7. When seed is in moisture-proof containers the opened or pierced container shall be adequately closed or the residues from sampling transferred to new containers. When seeds are in packets of 100g or less each packet may be considered as a primary sample and sufficient shall be taken at random to obtain a submitted sample of the prescribed minimum weight.

### Sampling from large containers or seed in bulk

8. For the sampling of containers holding more than 100kg of seed, and for the sampling of seed in bulk, primary samples shall be taken from different horizontal and vertical positions selected at random and the following shall be regarded as the minimum requirement-

LOT WEIGHT	NUMBER OF PRIMARY SAMPLES TO BE TAKEN
Up to 500kg	At least five primary samples
501-3,000kg	One primary sample for each 300kg but not less than 5
3,001-20,000kg	One primary sample for each 500kg but not less than 10
20,001kg and above	One primary sample for each 700kg but not less than 40

### Sampling from a seed stream

9. Samples may be drawn from a seed stream during processing using an automatic sampling device, which shall uniformly sample the entire cross-section of the seed stream when a sample is taken. Portions of seed shall be taken at regular intervals throughout the processing of the lot using the same sampling intensity for seed in bulk as specified in paragraph 8.

### Sampling Instruments

10. Sampling instruments shall be capable of sampling all parts of the seed lot. A dynamic spear sampler, stick sampler, cargo sampler or seed stream sampler of the type specified in paragraphs 12 to 14, 15 to 17, 18 or 19 respectively shall be used, as appropriate to the location of the seed, to draw primary samplers in accordance with the method described in paragraphs 21, 22 and 23, 24 or 25 respectively.

11. Where it is not practicable to use an instrument of the type referred to in paragraph 10 in accordance with a method referred to in paragraph 10 another instrument or method may be used at the discretion of the National Assembly.

### Dynamic spear sampler

12. A dynamic spear sampler may be used, in accordance with the method described in paragraph 21, for sampling seed in sacks or small containers. It shall be a hollow, cylindrical, solid-pointed metal spear or trier which shall be long enough to reach beyond the middle of the sack from the side and shall have an aperture so positioned that portions of seed of equal volume are removed from each part of the sack through which it travels.

13. In sampling seed of the species specified in column (1) of the following table a dynamic spear sampler shall be used of a type specified in column (2) and the type of spear used in respect of each species shall not be smaller than the type specified in the corresponding entry in column (2)-

<i>(1)</i> <i>Species of seed</i>	<i>(2)</i> <i>Type of dynamic spear sampler</i>
Alaska brome-grass	B
Alsike clover	A
Annual meadowgrass	A
Asparagus	B
Barley	B
Beetroot	B
Birdsfoot trefoil	A
Black medick	A

<i>(1)</i> <i>Species of seed</i>	<i>(2)</i> <i>Type of dynamic spear sampler</i>
Black mustard	A
Blue lupin (narrow leaved lupin)	C
Borecole	A
Broad bean	D
Brown mustard	A
Brown top	A
Brussels sprouts	A
Cabbage	A
Calabrese	A
Carrot	A
Cauliflower	A
Celeriac	A
Celery	A
Chard	A
Cheltenham beet	B
Chicory	A
Chinese cabbage	A
Cocksfoot	B
Common vetch	C
Creeping bent	A
Cucumber	B
Curley kale	A
Durum wheat	B
Endive	A
Festulolium	B
Field bean	C
Field pea (fodder pea)	B
Flax or linseed	B
Fodder beet	B
Fodder kale	A
Fodder radish	A
Fodder rape	A
French bean	D
Gerkin	B
Gourd	C

<i>(1)</i> <i>Species of seed</i>	<i>(2)</i> <i>Type of dynamic spear sampler</i>
Hairy vetch	C
Hungarian vetch	C
Hybrid ryegrass	B
Italian ryegrass (including Westerwolds)	B
Kohl rabi	A
Leaf beet	B
Leek	A
Lettuce	A
Linseed or flax	B
Lucerne	A
Maize	C
Mangel	B
Marrow	C
Meadow fescue	B
Melon	B
Narrow leaved lupin (blue lupin)	C
Oats	B
Oilseed rape	A
Onion	A
Parsley	A
Pea (vegetable)	C
Perennial ryegrass	B
Radish	A
Red beet (beetroot)	B
Red cabbage	A
Red clover	A
Red fescue	B
Red top	A
Rescue grass	B
Rough-stalked meadowgrass	A
Runner bean	D
Rye	B
Savoy cabbage	A
Sainfoin	B

<i>(1)</i> <i>Species of seed</i>	<i>(2)</i> <i>Type of dynamic spear sampler</i>
Sheep's fescue	B
Small timothy	A
Smooth-stalked meadowgrass	A
Soya bean	C
Spelt wheat	B
Spinach	B
Spinach beet	B
Sprouting broccoli	A
Sugar beet	B
Sunflower	C
Swede	A
Swede rape	A
Tall fescue	B
Tall oatgrass	B
Timothy	A
Tomato	A
Trefoil	A
Triticale	B
Turnip	A
Turnip rape	A
Velvet bent	A
Wheat	B
Wood meadowgrass	A
White lupin	C
White clover	A
White mustard	A
Yellow lupin	C

14. In the table set out in paragraph 13 references to type A, B, C and D instruments shall be construed as referring to instruments having a point length (a), shoulder length (b), boss length (c), aperture length (d), aperture width (e), bore width (f) and outside diameter (g) as shown in the diagram below of the dimensions specified in the corresponding entries in the following table-

Type of Instrument	Point length mm (a)	Shoulder length mm (b)	Boss length mm (c)	Aperture length mm (d)	Aperture width mm (e)	Bore width mm (f)	Outside diameter mm (g)
A	42	7	8	20	8	10	12
B	85	12	10	33	11	13	15
C	82	12	13	40	15	17	19
D	78	15	15	40	18	20	22

Dimensions (mm)

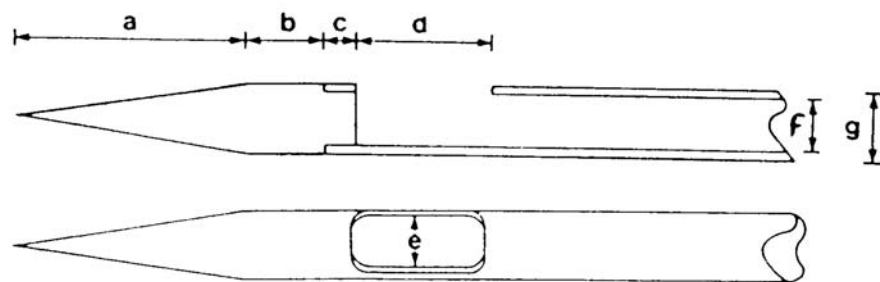

### Stick Samplers

15. A stick sampler may be used for drawing primary samples if it has an aperture or apertures of sufficient size to allow the unrestricted entry of seed or other particles and is capable of being opened and closed during the sampling procedure as appropriate to the method of use described in paragraph 22 or 23.

16. A single chamber type stick sampler may be used for sampling seed in open sacks, in large containers or in bulk.

Dimensions (mm)

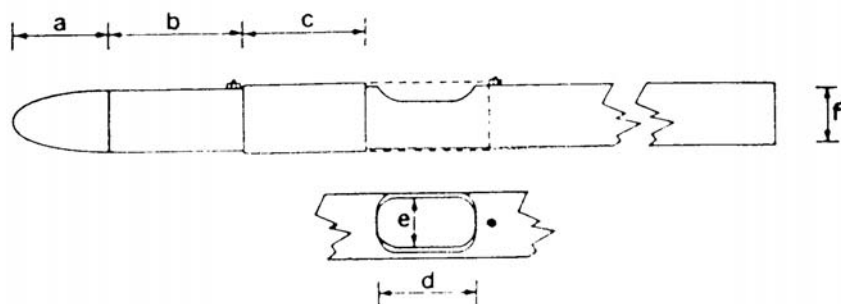



Dimensions (mm)

	<i>Point (a)</i>	<i>Shoulder (b)</i>	<i>Sliding Sleeve (c)</i>	<i>Aperture Length (d)</i>	<i>Aperture Width (e)</i>	<i>Bore (f)</i>
For sampling: Seeds in sacks.	55	25	75	50	22	25
Seeds in large containers or in bulk	100	390	63	50	22	30

17. A multi-chamber type stick sampler may be used to sample seed in sacks or, subject to the requirements of paragraph 10 above, any other containers. The apertures shall open into chambers that shall be separated from one another by transverse partitions. The contents of each chamber shall be regarded as a primary sample.

Dimensions (mm)

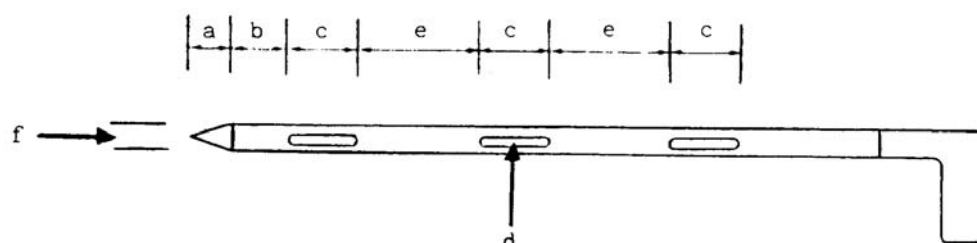

	<i>Point (a)</i>	<i>Shoulder (b)</i>	<i>Aperture Length (c)</i>	<i>Aperture Width (d)</i>	<i>Aperture Separation (e)</i>	<i>Bore (f)</i>
For sampling: All species:	60	50	100	15	110	25

### Cargo sampler

18. A cargo sampler may be used to draw primary samples of seed in accordance with the method described in paragraph 24 for sampling seed in large containers or bulk and shall only be used in the vertical position.

### Seed stream sampler

19. A seed stream sampler may be used to draw primary samples if it uniformly samples the cross-section of the seed stream without any loss of the seed that enter the sampler, in accordance with the method described in paragraph 25. Timing devices shall be attached so that the frequency and duration of sampling can be adjusted to meet the requirements of paragraph 9.

## **Methods of use**

20. All instruments shall be clean before use.

### **Dynamic seed sampler**

21.-(1) In the case of a dynamic spear sampler in which the aperture reaches only to the centre of the sack or small container-

- (a) the instrument shall be inserted into the sack in an upward direction at an angle of approximately 30° to the horizontal with its aperture downwards until the aperture reaches the centre of the sack or container;
- (b) it shall be lightly tapped to remove any seed taken in and then rotated to bring the aperture uppermost;
- (c) it shall be withdrawn immediately with a vibratory or oscillatory motion and at a decreasing speed so that the quantity of seed obtained from successive locations increases progressively from the centre to the side of the sack; and
- (d) seed passing through the instrument shall be collected in a clean container.

(2) In the case of a dynamic spear sampler in which the aperture reaches to the far side of the sack or small container-

- (a) the spear shall be inserted in the manner described in sub-paragraph (1) until its aperture reaches almost to the far side of the sack or container;
- (b) it shall be tapped and rotated in the manner described in sub-paragraph (1) and then withdrawn at a uniform speed; and
- (c) the seed passing through the instrument shall be collected in a clean container.

### **Single chamber type stick sampler**

22. In the case of a single chamber type stick sampler-

- (a) the sleeve shall move freely;
- (b) the instrument shall be inserted vertically downwards till the aperture reaches the appropriate primary sampling position ensuring that the sleeve covers the aperture as it enters the seed;
- (c) the instrument shall be withdrawn sufficiently to uncover the aperture;
- (d) the instrument shall be left in position until the primary sample has been collected; and
- (e) the instrument shall be withdrawn and the contents emptied into a clean container.

### **Multi-chamber type stick sampler**

23. In the case of a multi-chamber type stick sampler-

- (a) the apertures shall be closed before insertion;
- (b) the instrument shall be inserted diagonally into sacks or vertically into large containers so that all apertures are fully covered;
- (c) the apertures shall be opened;
- (d) the instrument shall be agitated so that seed enters;
- (e) the apertures shall be closed gently to ensure that trapped seed is not broken or damaged;
- (f) the instrument shall be withdrawn and if the chambers are full the contents shall be emptied onto a clean surface or into a clean container; and
- (g) if all the chambers are not full, the contents shall be discarded and procedures specified in sub-paragraphs (a) to (f) shall be repeated.

### **Cargo sampler**

24. In the case of a cargo sampler-

- (a) the lid shall open and close easily;
- (b) the instrument shall be inserted with the lid closed to the appropriate primary sampling position which shall be at least 300 mm below the surface of the seed;

- (c) the handle shall be raised sufficiently to open the lid;
- (d) the instrument shall be left in position until the primary sample has been collected; and
- (e) the instrument shall be withdrawn and the contents shall be emptied into a clean container.

### **Seed Stream Samplers**

25. In the case of a seed stream sampler, the instrument shall take the number of primary samples necessary for the weight of the seed lot being sampled, the primary samples being taken from the seed lot at regular intervals and the resultant composite sample being of a weight not less than the prescribed minimum weight and not greater than can conveniently be reduced by means of one of the methods of sample reduction described in paragraph 30. They shall be installed in such a way that the composite sample can be readily identified with the seed lot from which it was taken.

### **Obtaining a submitted sample- composite sample division instruments**

26. Provided the composite sample is of at least the prescribed minimum weight for the relevant species of seed, it may be used as the submitted sample.

27. Where the composite sample exceeds the prescribed minimum weight for the submitted sample, a riffle divider of the type specified in paragraph 28 or a centrifugal divider of the type specified in paragraph 29 may be used to obtain a submitted sample. Other instruments and methods may be used at the discretion of the National Assembly.

### **Riffle Divider**

28. The riffle divider shall consist of a rectangular hopper leading to a series of evenly spaced chutes, arranged so that seed is distributed equally on two sides. There shall be a minimum of 18 chutes, each discharging in the opposite direction to its immediate neighbour. Three (or more) metal collecting vessels (pans) of sufficient depth to prevent seed bouncing out shall be used.

### **Centrifugal Divider**

29. The centrifugal divider shall consist of a hopper from which the seed flows on to a shallow cup that is then rotated by an electric motor. The seed shall be distributed by centrifugal force onto a stationary baffle that divides it into two equal parts that are then discharged through separate spouts. Four metal collecting vessels (pans) of sufficient depth to prevent seed bouncing out shall be used.

### **Method of Use**

30. The method of using a riffle divider shall be as follows:-

- (a) the divider shall be placed on a firm level surface;
- (b) the divider and pans shall be clean;

### **Sample Mixing**

- (c) an empty pan shall be placed on each side of the divider to receive the discharge from the chutes;
- (d) the entire composite sample shall be poured evenly into the other pan(s);
- (e) the seed shall then be poured from the pan(s) evenly along the entire length of the hopper;
- (f) the two pans into which the seed has passed shall then be replaced with empty pans;
- (g) procedures (e) and (f) shall then be repeated twice to mix the sample thoroughly;

### **Sample Reduction**

- (h) before reduction, the composite samples shall have been thoroughly mixed using procedures (c) to (g). The contents of one of the two receiving pans shall then be set aside. If the seed in the second pan is of at least the prescribed minimum weight for a submitted sample of a particular species of seed, it may be used as the submitted sample. If the weight of seed in the second pan is greater than the appropriate prescribed minimum weight for a submitted sample, it may be reduced using the procedures specified in sub-paragraphs (i) to (k);

- (i) an empty pan shall be placed on each side of the divider to receive the discharge from the chutes;
- (j) the contents of the second pan shall be poured evenly along the entire length of the hopper;
- (k) the contents of one of the two pans into which the seed has been passed shall then be set aside. If the weight of seed in the other pan is still greater than the appropriate prescribed minimum weight for the submitted sample, it may be submitted intact or it may be reduced further using the procedures specified in sub-paragraphs (i) to (k);
- (l) if the weight of seed in either of the two pans at either (h) or (k) is less than the appropriate prescribed minimum weight for a submitted sample, the procedures specified in sub-paragraphs (m) to (q) shall be used;
- (m) an empty pan shall be placed on each side of the divider to receive the discharge from the chutes;
- (n) the contents of one of the pans shall be set aside. The contents of the other pan shall be poured evenly along the entire length of the hopper;
- (o) one receiving pan and its contents shall then be removed and replaced with an empty pan. The other pan, with its contents, shall be left in place;
- (p) the contents of the pan removed at (o) shall be poured evenly along the entire length of the hopper so that two subsamples of different weight shall be produced;
- (q) the procedures specified in sub-paragraphs (o) and (p) when repeated, constitute the process of continuous halving, and shall be repeated using whichever subsample is appropriate until sufficient seed is obtained in one pan, which when added to the seed set aside at (n) produces a submitted sample of at least the appropriate prescribed minimum weight;

#### **Obtaining more than one submitted sample**

- (r) two submitted samples shall be obtained from a composite sample by first obtaining a sample of at least twice the appropriate prescribed minimum weight for a submitted sample, using the procedures specified in sub-paragraphs (c) to (g) and (h) to (q) as appropriate, and then dividing it into two parts by passing it once through the divider;
- (s) when three submitted samples are required from one composite sample, one sample of at least the appropriate prescribed minimum weight for a submitted sample, shall be extracted using the procedures specified in sub-paragraphs (c) to (g) and (h) to (q) as appropriate. All portions of seed which have been set aside shall then be recombined and the residue of the composite sample so obtained shall be subject to the procedure specified at sub-paragraph (r).

#### **Centrifugal Divider**

**31.** The method of using a centrifugal divider shall be as follows-

- (a) the divider shall be levelled prior to use;
- (b) the divider and pans shall be clean;

#### **Sample Mixing**

- (c) an empty pan shall be placed under each spout of the divider;
- (d) the entire composite sample shall be poured into the centre of the hopper;
- (e) the motor shall be operated so that the seed passes into the pans;
- (f) the motor shall be switched off;
- (g) the two pans containing seed shall be removed and replaced by empty ones;
- (h) the contents of both pans removed at (g) shall be poured together into the centre of the hopper, the seed being allowed to blend as it flows in. The procedures specified in sub-paragraphs (e), (f) and (g) shall be repeated;
- (i) the procedure specified in sub-paragraph (h) shall be repeated to mix the sample thoroughly;

#### **Sample Reduction**

- (j) before reduction, the composite sample shall have been thoroughly mixed using the procedures specified in sub-paragraphs (c) to (i). The contents of one of the two receiving pans shall then be set aside. If the seed in the second pan is of at least the prescribed minimum weight for a submitted sample of a particular

species of seed, it may be used as the submitted sample. If the weight of seed in the second pan is greater than the appropriate prescribed minimum weight for a submitted sample, it may be reduced using the procedures specified in sub-paragraphs (k) to (m);

- (k) empty pans shall be placed under the spouts;
- (l) the contents of the second pan shall be poured into the hopper and the procedures specified in sub-paragraphs (e) and (f) shall be repeated;
- (m) the contents of one of the two pans into which the seed has passed shall then be set aside. If the weight of seed in the other pan is still greater than the appropriate minimum prescribed weight for a submitted sample, it may be submitted intact or it may be reduced further using the procedures specified in sub-paragraphs (k) to (m);
- (n) if the weight of seed in either of the two pans at either (j) or (m) is less than the appropriate prescribed minimum weight for a submitted sample, the procedures specified in sub-paragraphs (o) to (s) shall be used;
- (o) empty pans shall be placed under the spouts;
- (p) the contents of one of the pans shall be set aside, the contents of the other pan shall be poured into the centre of the hopper and the procedures specified in sub-paragraphs (e) and (f) shall be repeated;
- (q) one receiving pan and its contents shall then be removed and replaced with an empty pan; the other pan, with its contents, shall be left in place;
- (r) the contents of the pan removed at (q) shall be poured into the centre of the hopper and the procedures specified in sub-paragraphs (e) and (f) shall be repeated so that two sub-samples of different weight shall be produced;
- (s) the procedures specified in sub-paragraphs (q) and (r) above, when repeated, constitute the process of continuous halving, and shall be repeated using whichever sub-sample is appropriate until sufficient seed is obtained in one pan, which when added to the seed set aside at (p) produces a submitted sample of at least the appropriate prescribed minimum weight;

#### **Obtaining more than one submitted sample**

- (t) two submitted samples shall be obtained from a composite sample by first obtaining a sample of at least twice the appropriate prescribed minimum weight for a submitted sample, using the procedures specified in sub-paragraphs (c) to (i) and (j) to (s) as appropriate, and then dividing it into two parts by passing it once through the divider;
- (u) when three submitted samples are required from one composite sample, one sample, of at least the appropriate prescribed minimum weight for a submitted sample, shall be extracted using the procedures specified in sub-paragraphs (c) to (i) and (j) to (s) as appropriate. All portions of seed which have been set aside shall then be recombined and the residue of the composite sample so obtained shall be subject to the procedure specified in sub-paragraph (t).

#### **Moisture Sample**

32. Primary samples of seed for moisture tests shall be drawn in such a way as to minimise exposure to the atmosphere. The composite moisture sample so collected may, if his or her licence permits it, be tested by a licensed seed sampler but shall in any other case be submitted intact to the testing station in an airtight container. It shall not be passed through a seed divider. Seed for moisture tests shall be kept separate from seed on which other determinations are to be made.

SCHEDULE 6

CERTIFICATE OF THE TAKING OF A SAMPLE OF SEEDS

NATIONAL ASSEMBLY FOR WALES

PLANT VARIETIES AND SEEDS ACT 1964- SECTION 26(3)

THE SEED (REGISTRATION, LICENSING AND ENFORCEMENT) (WALES) REGULATIONS 2005

CERTIFICATE OF THE TAKING OF A SAMPLE OF SEEDS TAKEN UNDER SECTION 25(5) OF THE ACT

I certify that in taking the sample referred to above I used one of the methods of sampling prescribed in the appropriate part of Schedule 5 of the Seed (Registration, Licensing and Enforcement) (Wales) Regulations 2005.

Signed

Authorised by the National Assembly

Name (in BLOCK LETTERS)

Date

Sample taken on the premises of: (name) _____	
Address _____	
Post code _____	
1. Species _____	
2. Variety _____	
3. (a) Category (specify) _____ (b) Level (specify) _____	
4. Date of sampling _____	
5. Seed lot reference number _____	
6. Quantity sampled	7. Treatment _____
(i.e. total weight of seed from which the sample was taken) <input type="text"/>	(Specify trade name)
8. Date of sampling _____	
9. Date of sampling _____	

10. Date received at OSTs

11. Mixtures: (enter details as appropriate)

Species			
Varieties			
Prop. By weight			
Ref. No. of lot			
Species			
Varieties			
Prop. By weight			
Ref. No. of lot			

12. Moisture sample taken

 YES NO

13. Country of production

14. Should the result be sent  
to these premises?

 YES NO

If NO, please state name and address for result to be sent to

Post code:	Reg. No.

15. Sample taken from (type of container-  
please specify) :

16. Remarks

SCHEDULE 7

CERTIFICATES OF THE RESULTS OF TESTS OF SEEDS

PART I

NATIONAL ASSEMBLY FOR WALES

PLANT VARIETIES AND SEEDS ACT 1964- SECTION 24(5)

THE SEED (REGISTRATION, LICENSING AND ENFORCEMENT) (WALES) REGULATIONS 2005

THE CEREAL SEED (WALES) REGULATIONS 2005

REPORT OF THE OFFICIAL SEED TESTING STATION FOR WALES ON A SAMPLE TAKEN UNDER SECTION 25(5) OF THE ACT

On the premises of (Name and Address)

[ ]

Official Station Sample No. ....

Control Sample No. ....

Date received at Station ....

Date of sampling ....

[ ]

Quantity sampled .....

Description

Species 

Variety 

Category and level 

Reference No. 

Result of Test

% Pure seed	% Inert matter	% Other seeds	% Solid additives

Inert matter

Other seeds

Number of seeds

	500g	Further 500g	TOTAL 1kg
Other cultivated cereal spp.			
Spp. other than cultivated cereals			
Total			
<i>Avena fatua, A. ludoviciana, A. sterilis</i>			



<i>Lolium temulentum</i>			
<i>Raphanus raphanistrum</i>			
<i>Agrostemma githago</i>			
<i>Agropyron repens</i>			
<i>Bromus sterilis</i>			
Ergot			

Number of Pieces

Loose smut infection % in ..... embryos examined  Pre-treated for dormancy

Germination %  Fresh seed %  Moisture Content %

Varietal Purity, declared variety %  Other varieties %  Date

Remarks:

.....  
CHIEF OFFICER

PART II

NATIONAL ASSEMBLY FOR WALES

PLANT VARIETIES AND SEEDS ACT 1964- SECTION 24(5)

THE SEED (REGISTRATION, LICENSING AND ENFORCEMENT) (WALES) REGULATIONS 2005

THE CEREAL SEED (WALES) REGULATIONS 2005

REPORT OF THE OFFICIAL SEED TESTING STATION FOR WALES ON A SAMPLE TAKEN UNDER SECTION 25(5) OF THE ACT

On the premises of (Name and Address)

[ ]

Official Station Sample No. ....

Control Sample No. ....

Date received at Station ....

Date of sampling ....

[ ]

Quantity sampled .....

Description

Species

Variety

Category and level

Reference No.

Result of Test

% Pure seed	% Inert matter	% Other seeds	% Solid additives

% <i>Agropyron repens</i>	% <i>Alopecurus myosuroides</i>
% <i>Raphanus raphanistrum</i>	% <i>Sinapis arvensis</i>
	% <i>Melilotus spp</i>

Inert matter

Other seeds

Number of seeds

Agropyron repens		
Alopecurus myosuroides		

<i>Avena fatua</i> , <i>A. ludoviciana</i> , <i>A. sterilis</i>		
<i>Cuscuta spp.</i>		
<i>Melilotus spp.</i>		
<i>Rumex spp.</i> other than <i>R. acetosella</i> and <i>R. maritimus</i>		

No. of seeds infected with *Ascochyta fabae* in .....seeds examined

Germination %  Hard seed %  Fresh seed %

Varietal purity  
Declared variety %  Other varieties %  Date

Remarks:

.....  
CHIEF OFFICER

PART III

NATIONAL ASSEMBLY FOR WALES

PLANT VARIETIES AND SEEDS ACT 1964- SECTION 24(5)

THE SEED (REGISTRATION, LICENSING AND ENFORCEMENT) (WALES) REGULATIONS 2005

THE CEREAL SEED (WALES) REGULATIONS 2005

REPORT OF THE OFFICIAL SEED TESTING STATION FOR WALES ON A SAMPLE TAKEN UNDER SECTION 25(5) OF THE ACT

On the premises of (Name and Address)

[ ]	Official Station Sample No.	.....
	Control Sample No.	.....
	Date received at Station	.....
	Date of sampling	.....
[ ]	Quantity sampled	.....

Description

Species		Variety	
Category and level		Reference No.	

Result of Test

% Pure seed	% Inert matter	% Other seeds	% Solid additives

Inert matter

Other seeds

Germination  %

Germinated clusters with-

One seedling  %

Two seedlings  %

Three or more seedlings  %

Moisture content  %      Date

Remarks:

.....

CHIEF OFFICER

PART IV

NATIONAL ASSEMBLY FOR WALES

PLANT VARIETIES AND SEEDS ACT 1964- SECTION 24(5)

THE SEED (REGISTRATION, LICENSING AND ENFORCEMENT) (WALES) REGULATIONS 2005

THE CEREAL SEED (WALES) REGULATIONS 2005

REPORT OF THE OFFICIAL SEED TESTING STATION FOR WALES ON A SAMPLE TAKEN UNDER SECTION 25(5) OF THE ACT

On the premises of (Name and Address)

[ ]

Official Station Sample No. ....

Control Sample No. ....

Date received at Station ....

Date of sampling ....

[ ]

Quantity sampled .....

Description

Species

--

Variety

--

Category and level

--

Reference No.

--

Result of Test

% Pure seed	% Inert matter	% Other seeds

% Solid additives

Inert matter

Other seeds

Germination %

--

Fresh seed %

--

No. of seeds infected with ..... in ..... seeds examined

--

Date

--

Remarks:

.....  
CHIEF OFFICER

PART V

NATIONAL ASSEMBLY FOR WALES

PLANT VARIETIES AND SEEDS ACT 1964- SECTION 24(5)

THE SEED (REGISTRATION, LICENSING AND ENFORCEMENT) (WALES) REGULATIONS 2005

THE CEREAL SEED (WALES) REGULATIONS 2005

REPORT OF THE OFFICIAL SEED TESTING STATION FOR WALES ON A SAMPLE TAKEN UNDER SECTION 25(5) OF THE ACT

On the premises of (Name and Address)

[ ]

Official Station Sample No. ....

Control Sample No. ....

Date received at Station ....

Date of sampling ....

[ ]

Quantity sampled .....

Description

Species

Variety

Category and level

Reference No.

Result of Test

% Pure seed	% Inert matter	% Other seeds

% Solid additives

Inert matter

Other seeds

Number of seeds

Other plant species		
<i>Avena fatua</i> , <i>A. ludoviciana</i> , <i>A. sterilis</i>		
<i>Cuscuta spp.</i>		
<b><i>Raphanus raphanistrum</i></b>		
<i>Rumex spp.</i> other than <i>Rumex acetosella</i>		
<i>Alopecurus myosuroides</i>		
<i>Lolium remotum</i>		

Number of Pieces 

Sclerotia of Sclerotinia sclerotiorum	
---------------------------------------	--

Germination %  Fresh seed %  Date

Remarks:

.....  
CHIEF OFFICER







---

STATUTORY INSTRUMENTS

---

**2005 No. 3038 (W.226)**

**SEEDS, WALES**

**The Seed (Registration, Licensing and Enforcement) (Wales) Regulations  
2005**

© Crown copyright 2005

Printed and Published in the UK by the Stationery Office Limited  
under the authority and superintendence of Carol Tullo,  
Controller of Her Majesty's Stationery Office and Queen's Printer of  
Acts of Parliament.





**Cyhoeddwyd gan The Stationery Office Limited**  
ac mae ar gael oddi wrth:

**The Stationery Office**

(Archebion post, ffon a ffacs yn unig)  
PO Box 29, Norwich NR3 1GN  
Archebion / ymholiadau ffôn 0870 600 5522  
Archebion ffacs 0870 600 5533  
[book.orders@theso.co.uk](mailto:book.orders@theso.co.uk)  
<http://www.ukstate.com>

**Siopau Llyfrau The Stationery Office**

Siop Lyfrau y Llyfrfa Oriel  
18-19 Heol Fawr, Caerdydd CF1 2BZ  
029 2039 5548 Ffacs 029 2038 4347  
123 Kingsway, Llundain WC2B 6PQ  
0207 942 6393 Ffacs 0207 242 6394  
68-69 Bull Street, Birmingham B4 6AD  
0121 236 9696 Ffacs 0121 236 9699  
9-21 Princess Street, Manceinion M60 8AS  
0161 834 7201 Ffacs 0161 833 0634  
16 Arthur Street, Belfast BT1 4GD  
028 9023 8451 Ffacs 028 9023 5401  
71 Lothian Road, Caeredin EH3 9AZ  
0870 606 5566 Ffacs 0870 606 5588

Asiantau Achrededig  
(gweler Yellow Pages)

*a thrwy lyfrwerthwyr da.*



**Published by The Stationery Office Limited**  
and available from:

**The Stationery Office**

(Mail, telephone and fax orders only)  
PO Box 29, Norwich NR3 1GN  
Telephone orders / enquiries 0870 600 5522  
Fax orders 0870 600 5533  
Email orders [book.orders@theso.co.uk](mailto:book.orders@theso.co.uk)  
<http://www.ukstate.com>

**The Stationery Office Oriel Bookshop.**

18-19 High Street, Cardiff CF1 2BZ  
029 2039 5548 Fax 029 2038 4347  
The Stationery Office Bookshops at:  
123 Kingsway, London WC2B 6PQ  
0207 242 6393 Fax 0207 242 6394  
68-69 Bull Street, Birmingham B4 6AD  
0121 236 9696 Fax 0121 236 9699  
9-21 Princess Street, Manchester M60 8AS  
0161 834 7201 Fax 0161 833 0634  
16 Arthur Street, Belfast BT1 4GD  
01232 238451 Fax 01232 35401  
71 Lothian Road, Edinburgh EH3 9AZ  
0131 228 4181 Fax 0131 622 7017

Accredited Agents  
(see Yellow Pages)

*and through good booksellers.*

ISBN 0-11-091213-6



9 780110 912134